



**Structural
Environmental
Services**

STORMWATER MANAGEMENT REPORT

3996 Innes Road, Ottawa

Prepared by

E AU Structural & Environmental Services

Ottawa, Ontario, K1Y 4P9
Phone: 613 869 0523
Email: derrick.r.clark@rogers.com

Revision 1
December 2022

Table of Contents

- 1. Introduction**
- 2. Stormwater Design.**
- 3. Stormwater Quantity Control**
- 4. Quality Control**
- 5. Foundation/Footing Drain**
- 6. Erosion and Sediment Control**
- 7. Conclusion**

Appendixes

Drainage Area

Stormwater management calculation

Engineering Drawings and References

Architectural Drawings

1. Introduction

The property at 3996 Innes Road is located close to intersection of Mer Bleue Road and Innes Rd. The existing lot is 0.15 hectare, currently, contains a one story buildings built in circa 1970. It is proposed that the existing building to be demolished and a new 5-storey commercial/residential building be constructed. Property at 3996 Innes Road is currently zoned as AM (Arterial Mainstreet Zoning) which suits for the purpose of proposed development.

This report will address the servicing requirements associated with the proposed development located at 3996 Innes Road within the City of Ottawa. This report is prepared in response to the request from City of Ottawa Planning department.

1.1. Existing Conditions:

The property measure a total area of approximately 0.15 hectare. The site is fronting 610mm diameter DI water main, 250mm diameter PVC sanitary main and 600mm diameter concrete storm main.

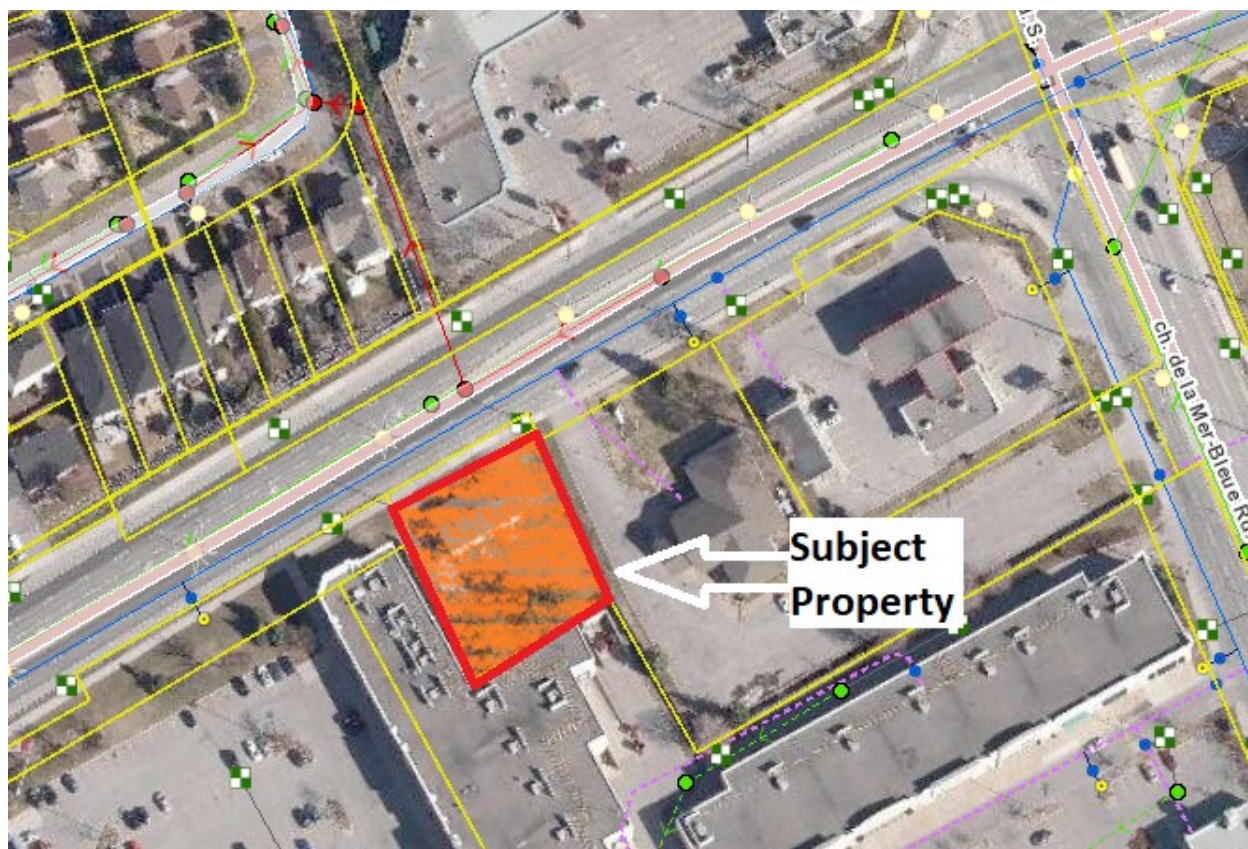

1.2. Guidelines, Previous Studies, And Reports

The following studies were utilized in the preparation of this report:

- Ottawa Sewer Design Guidelines,
City of Ottawa, SDG002, October 2012.
(City Standards)
 - Technical Bulletin ISTB-2018-01
City of Ottawa, March 21, 2018.
(ISTB-2018-01)
 - Technical Bulletin ISTB-2018-04
City of Ottawa, June 27, 2018.
(ISTB-2018-04)

- Ottawa Design Guidelines Water Distribution
City of Ottawa, July 2010.
(Water Supply Guidelines)
 - Technical Bulletin ISD-2010-2
City of Ottawa, December 15, 2010.
(ISD-2010-2)
 - Technical Bulletin ISDTB-2014-02
City of Ottawa, May 27, 2014.
(ISDTB-2014-02)
 - Technical Bulletin ISTB-2018-02
City of Ottawa, March 21, 2018.
(ISTB-2018-02)

- Design Guidelines for Sewage Works,
Ministry of the Environment, 2008.
(MOE Design Guidelines)

- Stormwater Planning and Design Manual,
Ministry of the Environment, March 2003.
(SWMP Design Manual)

- Ontario Building Code Compendium
Ministry of Municipal Affairs and Housing Building Development Branch,
January 1, 2012 Update. (OBC)

- Geotechnical Report
Prepared by Paterson Group
Report Number: PG5925-1
Dated, November 17, 2021

2. Stormwater Design

2.1. Design Criteria

Design of the storm sewer system was completed in conformance with the City of Ottawa Design Guidelines for Sewage Works, Stormwater Management Planning, Design Manual Ontario Ministry of Environment and City of Ottawa Sewer Design Guideline, October 2012.

The site is currently contains a one-storey dwelling. There is no stormwater management on current property. Pre-development conditions will be considered as the lesser of current conditions or conditions resulting in a runoff coefficient of 0.5. Based on the existing ground cover, as show in table below, the pre-development runoff coefficient was considered to be 0.50, which is the C value for grass or vegetation. The 5 year storm event, time of concentration that will be calculated and store up to the 100 years storm event as per direction from the City of Ottawa Planning Department.

Area ID	Area (ha)	Runoff 'C'	A x C
Existing Dwelling	0.05	0.9	0.045
Existing Driveways	0.03	0.9	0.027
Grass or Landscape	0.07	0.1	0.007
Total Site Area (ha)	0.15	---	0.079

Existing C(avg) = 0.53
Therefore Predevelopment C = 0.5

During all construction activities, erosion and sediment shall be controlled by techniques outlined in Section 5 of this report.

2.2. Minor System Design Criteria

- The storm sewers designed based on the rational formula and the Manning's Equation under free flow conditions for the 5-year storm using 10 min time of concentration.
- Inflow rates into the minor system are limited to the pre-development rates for up to the 5-year storm, and are based on a time of concentration of 10 min.

2.3. Major System Design Criteria

- The major system has been designed to accommodate runoff of 100 year event and above to flow via overland and not to impact adjacent properties.

2.4. Runoff Coefficients

The area for runoff coefficients used for either pre-development or post-development conditions were based on actual areas measured in CAD. Runoff coefficients for surfaces such as roofs, were taken as 0.90, for driveway and parking area were taken as 0.90 due to asphalt used for paving, and for grass area taken as 0.20. Average runoff coefficient for post development is calculated as 0.76 Refer to appendixes for detail.

2.5. Time of concentration

The time of concentration is taken as 10 minutes as per the City of Ottawa Design Guideline.

2.6. Allowable Release Rate

The allowable release rate from the site was determined using the modified rational method with a 5 years storm, a runoff coefficient $C=0.5$, and a time of concentration of 10 minutes as follows;

- Time of Concentration = 10 minutes,
- Drainage Area = 0.15 ha

$$Q_{\text{allow}} = 2.78 C I A$$

Where:

Q allow	=	Allowable release rate to storm sewer (L/sec)
C	=	Runoff Coefficient (dimensionless) =0.5
I	=	Average Rainfall Intensity for return period (mm/hr)
	=	$998.071/(T_c+6.053)^{0.814} = 104.20 \text{ mm/hr}$
T _c	=	Time of concentration (minutes)
A	=	Drainage Area (hectares) = 0.15

$$Q_{\text{Allow}} = 21.72 \text{ L/sec}$$

Therefore the allowable release rate from the site is 21.72 L/sec.

3. Stormwater Quantity Control

Post development storm water management design for this site includes 3 general areas; Grass area, Roof and Driveway area.

- Grass area will sheet drain to the front of the property as per natural drainage pattern.
- Drive way will be working as open storage area for retaining 5yr & 100yr storm event.
- Roof: Storm runoff during 5yrs and 100yrs storm event will be stored in parking and driveway area.

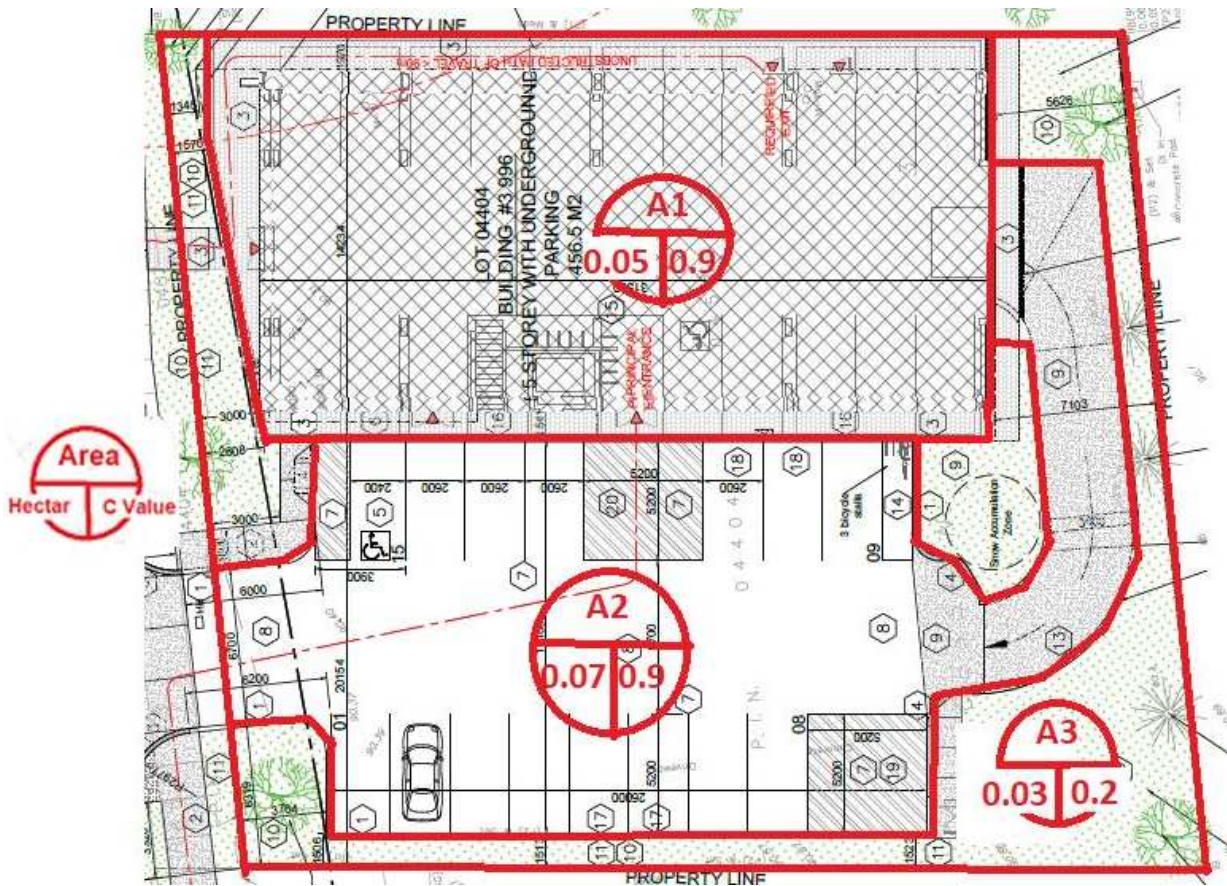

As ponds generally form the shape of a cone, the extend and depth of ponding resulting from the 100-year storm was determined using the following equation;

$$V = \frac{1}{3} \times A \times d$$

Where:

- V = Storage volume (cu. m.)
- A = surface area of pond (sq.m.)
- D = pond depth at peak (m)

Detail of calculation can be found in appendixes. Below is the summary of our calculation:

- Post-development flow rate shall be restricted to pre-development flow rate; 21.72 L/sec refer to section 2.6 for detail. Since the post-development grass area discharge is uncontrolled and discharges as per the natural drainage pattern, the grass discharge rate is deducted from allowable rate that will come up to $21.72 \text{ L/s} - 1.74 \text{ L/s}$ (grass area discharge) = 19.99 L/s . Therefore, post-development release rate will be restricted to 19.99 L/s .
- Based on the calculation, the maximum required storage for 5yr and 100yr storm event is 7.82 m^3 and 27.60 m^3 respectively.
- 100yr plus 20% due to climate change consideration would bring the required ponding to 33.12 m^3
- Side parking area is considered for providing required storage for 5yr and 100yr storm event. Based on maximum ponding height of 150mm, and based on cone formula, available storage will be 35m^3 which is satisfactory.

The discharge rate from above connected ponding area will be controlled via ICD which is selected based on Hydrovex flow regulator; 75VHV-1. Refer to appendix for additional information from the manufacturer. Refer to Grading plan attached this report for additional information.

4. Quality Control

Storm monitoring manhole will be installed inside the property line, prior to discharge to the storm main on Innes road. Also, Stormceptor, STC-450i is installed to remove 80% TSSA as per the requirement of the conservation authority. Refer to the grading plan for the location of the manholes and appendixes for additional information.

5. Foundation/Footing Drain

Foundation drain is independently connected to storm main on Stewart Street. Please refer to Grading & Drainage plan and Geotechnical Report.

6. Geotechnical Report Recommendation

The Geotechnical report, by Patersongroup Inc., recommends that a perimeter foundation drainage system be provided for the proposed structures. The system should consist of a 100 to 150 mm diameter perforated, corrugated plastic pipe which is surrounded on all sides by 150 mm of 19 mm clear crushed stone and is placed at the footing level around the exterior perimeter of the structure. The pipe should have a positive outlet, such as a gravity connection to the storm sewer.

Waterproofing of the foundation walls may be required if more than one underground level is anticipated. Due to the lack of bedrock coring, the groundwater table depth was not accurately

measure below the bedrock surface. However, based on the current information, waterproofing is not anticipated to be required if one underground level is being considered. The requirement for waterproofing should be confirmed by Paterson upon commencement of excavation when the groundwater infiltration can be better assessed.

All other Geotechnical recommendation shall be implemented on its entire context.

7. Best Management Practice for Low Impact Development

As for stormwater filter and infiltration practice, grass area acts as primary bio-filter. Dense grass or vegetation area acts as better bio-filter. The topsoil is also a primary filtration prior to the rainwater absorbent. Increasing topsoil by a few centimeter would considerably increase the capacity of soil filtration.

8. Erosion and Sediment Control

Following methods will be unutilized to control erosion and sediment:

- Silt fence will be installed around the perimeter of the site and will be cleaned and maintained throughout construction. Silt fence will remain in place until the working areas have been stabilized and re-vegetated.
- Catch basins will have GEO-Fabric or an approved equivalent installed under and over the grate during construction to protect from silt entering the storm sewer system.
- A mud mat will be installed at the construction access in order to prevent mud tracking onto adjacent roads.
- Erosion and sediment controls must be in place during construction. The following recommendations to the contractor will be included in contract documents:
 - Limit extent of exposed soils at any given time;
 - Re-vegetate exposed areas as soon as possible;
 - Minimize the area to be cleared and grubbed;
 - Protect exposed slopes with plastic or synthetic mulches;
 - Install silt fence to prevent sediment from entering existing ditches;
 - No refueling or cleaning of equipment near existing watercourses;
 - Provide sediment traps and basins during dewatering;
 - Install filter cloth between catch basins and frames;
 - Plan construction at proper time to avoid flooding;
 - Establish material stockpiles away from watercourses, so that barriers and filters may be installed.
- The contractor will, at every rainfall, complete inspections and guarantee proper performance. The inspection is to include:
 - Verification that water is not flowing under silt barriers;
 - Clean and change filter cloth at catch basins.

- Construction and maintenance requirements for erosion and sediment controls to comply with Ontario Provincial Standard Specification OPSS 577, and City of Ottawa specifications.
- A visual inspection shall be completed daily on sediment control barriers and any damage repaired immediately. Care will be taken to prevent damage during construction operations.
- Proposed CBs are to have erosion protection as identified within the stormwater management report. The maintenance of the CB erosion protection shall be regular inspections and debris removal as required.
- Refer to Erosion and Sediment control plan in appendix for more detail.

9. Conclusions

This report addresses the storm water management of the proposed site. The following list below itemizes the conclusions of this report.

- The allowable release rate for the site and required storage volume for 5year and 100year storm event calculated.
- Runoff from the roof and parking area will be retained in the parking and driveway area then discharged to the City storm system via an ICD
- During all construction activities, erosion and sedimentation shall be controlled by techniques outlined in this report.

Should you have any question, do not hesitate to let us know.



Derrick R. Clark, PEng.
EAU Structural & Environmental Services
Telephone: (613) 869 0523
derrick.r.clark@rogers.com

APPENDIX A:

Storm Drain Area

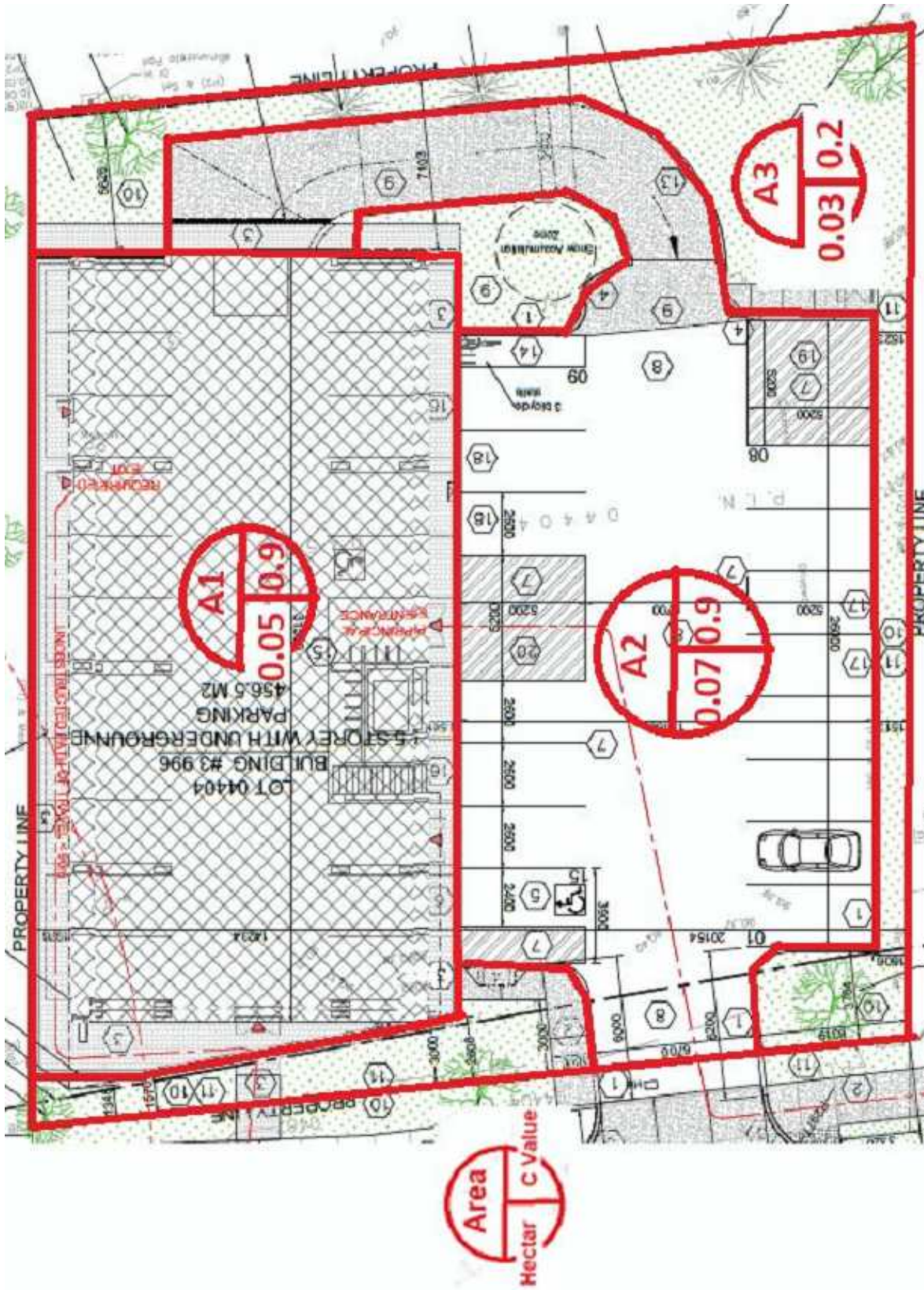

APPENDIX B:

Stormwater Management Calculation

C(max equiv)	I (mm/h)	Area (ha)	Q(allow)
0.5	104.2	0.150	21.72 L/s
C (Un-controlled)			
0.2	104.2	0.030	1.74 L/s
			Q(allow) 19.99 L/s

Area ID	Area (ha)	C (5yr)	A x C	C (100yr) (Max of 1.0)	A x C	Type of Flow (Controlled/Uncontrolled)
A1: Proposed Building	0.050	0.9	0.05	1.00	0.05	Controlled
A2: Parking area	0.070	0.9	0.06	1.00	0.07	Controlled
A3: Grass area	0.030	0.2	0.01	0.25	0.01	Un-controlled
Total Site Area (ha)	0.15	---	0.11	---	0.13	Total

C(avg) 5-year = 0.76
 C(avg) 100-year = 0.85

STORAGE CALCULATIONS

C(5 gr)	C(100 gr)	Area (ha)
0.76	0.85	0.150

Q(restricted) l/s = 19.99

t(c)min	I(mm/h)	Q(unrestricted) l/s	Q(restricted) l/s	Q(stored) l/s	V(stored) m ³
5	141.2	44.74	19.99	24.76	7.43
10	104.2	33.02	19.99	13.03	7.82
15	83.6	26.48	19.99	6.49	5.85
20	70.3	22.26	19.99	2.28	2.73
25	60.9	19.30	19.99	-0.69	-1.03
30	53.9	17.09	19.99	-2.90	-5.21
35	48.5	15.38	19.99	-4.61	-9.68
40	44.2	14.00	19.99	-5.98	-14.36
45	40.6	12.88	19.99	-7.11	-19.20
50	37.7	11.93	19.99	-8.05	-24.16
55	35.1	11.13	19.99	-8.86	-29.22
60	32.9	10.44	19.99	-9.55	-34.37
65	31.0	9.84	19.99	-10.15	-39.58
70	29.4	9.31	19.99	-10.68	-44.85
75	27.9	8.84	19.99	-11.15	-50.17
80	26.6	8.42	19.99	-11.57	-55.53
85	25.4	8.04	19.99	-11.95	-60.93
90	24.3	7.70	19.99	-12.29	-66.36
95	23.3	7.39	19.99	-12.60	-71.82
100	22.4	7.10	19.99	-12.89	-77.31
105	21.6	6.84	19.99	-13.15	-82.82
110	20.8	6.60	19.99	-13.39	-88.36

Max Vol stored 7.82

STORAGE TABLE (100 Yr Storm)

t(c)min	I(100yr) mm/h	Q(actual) l/s	Q(restricted) l/s	Q(stored) l/s	V(stored) m ³
5	242.7	86.0	20.0	66.0	19.81
10	178.6	63.3	20.0	43.3	25.98
15	142.9	50.6	20.0	30.7	27.60
20	120.0	42.5	20.0	22.5	27.04
25	103.8	36.8	20.0	16.8	25.23
30	91.9	32.6	20.0	12.6	22.64
35	82.6	29.3	20.0	9.3	19.50
40	75.1	26.6	20.0	6.6	15.96
45	69.1	24.5	20.0	4.5	12.12
50	64.0	22.7	20.0	2.7	8.05
55	59.6	21.1	20.0	1.1	3.79
60	55.9	19.8	20.0	-0.2	-0.63
65	52.6	18.7	20.0	-1.3	-5.17
70	49.8	17.6	20.0	-2.3	-9.82
75	47.3	16.7	20.0	-3.2	-14.56
80	45.0	15.9	20.0	-4.0	-19.39
85	43.0	15.2	20.0	-4.8	-24.28
90	41.1	14.6	20.0	-5.4	-29.24
95	39.4	14.0	20.0	-6.0	-34.25
100	37.9	13.4	20.0	-6.6	-39.31
105	36.5	12.9	20.0	-7.0	-44.41
110	35.2	12.5	20.0	-7.5	-49.56

Max Vol stored 27.60

APPENDIX C:
Drawings and General Specifications

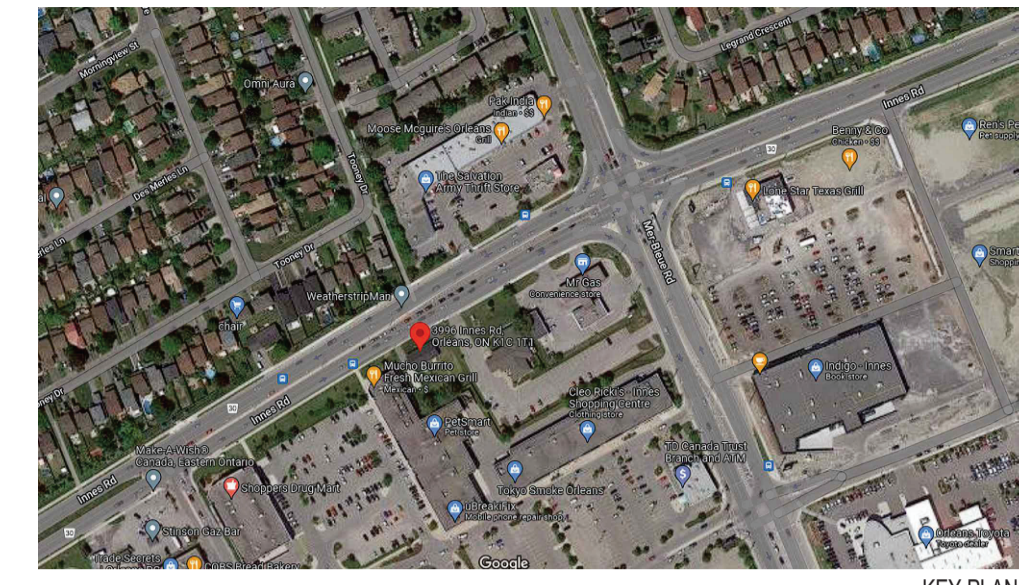
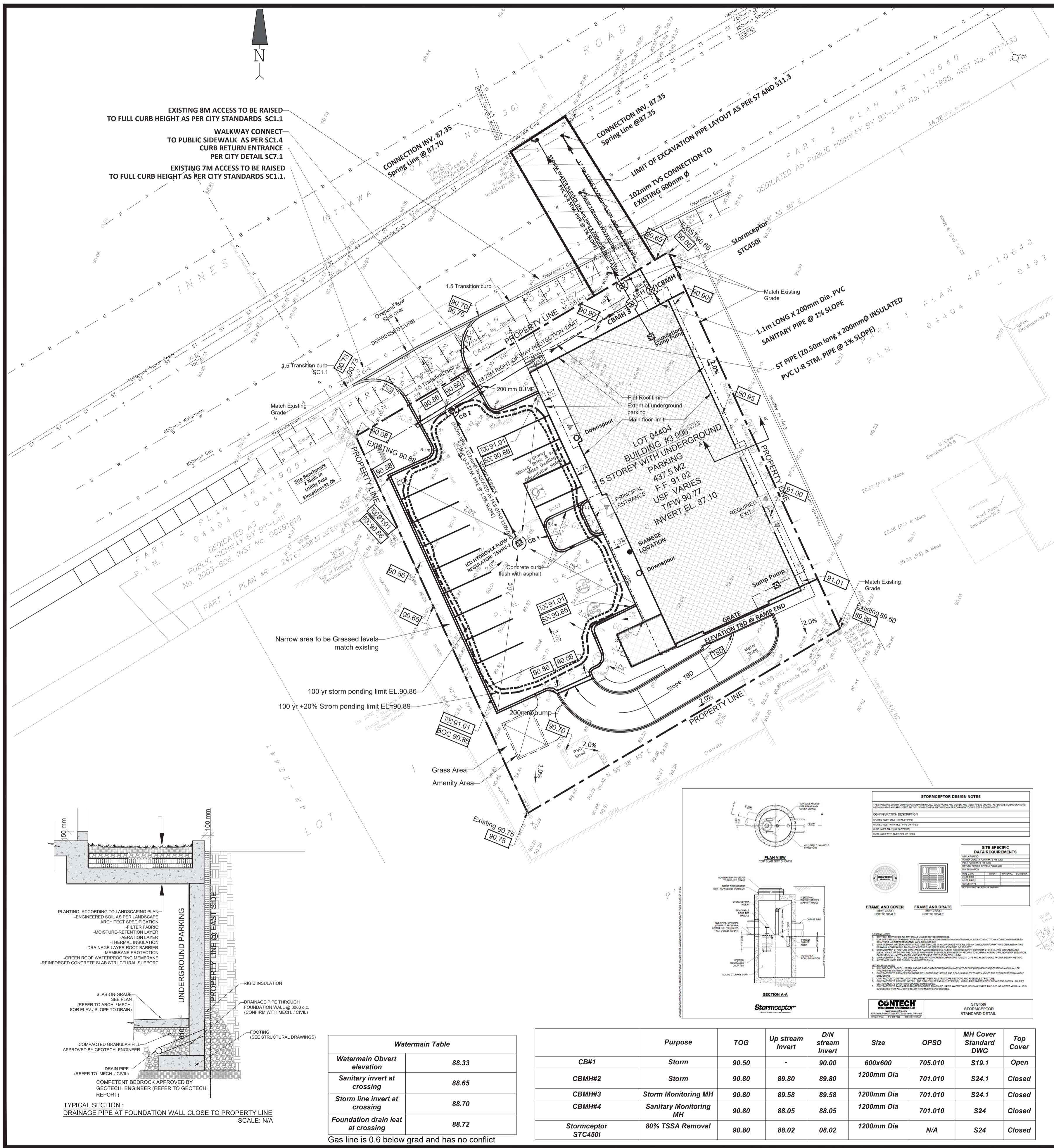

KEY PLAN

GENERAL NOTES FOR SERVICING

1. ALL SERVICES, MATERIALS, CONSTRUCTION METHODS AND INSTALLATIONS SHALL BE IN ACCORDANCE WITH THE LATEST STANDARDS AND REGULATIONS FOR THE CITY OF OTTAWA STANDARD SPECIFICATION AND DRAWINGS, ONTARIO PROVINCIAL STANDARD DRAWINGS (OPSD), UNLESS OTHERWISE SPECIFIED, TO THE SATISFACTION OF THE CITY AND THE CONSULTANT.
2. THE POSITION OF EXISTING POLE LINES, CONDUITS, WATER MAINS, SEWERS AND OTHER UNDERGROUND AND ABOVEGROUND UTILITIES, STRUCTURES AND APPURTENANCES OF THE POSITION OF SUCH UTILITIES AND STRUCTURES IS NOT GUARANTEED. PRIOR TO CONSTRUCTION, THE CONTRACTOR SHALL SATISFY HIMSELF OF THE EXACT LOCATION OF ALL SUCH UTILITIES AND STRUCTURES AND SHALL ASSUME LIABILITY FOR DAMAGE TO THEM DURING THE COURSE OF CONSTRUCTION. ANY RELOCATION OF EXISTING UTILITIES REQUIRED BY THE DEVELOPMENT OF SUBJECT LANDS IS TO BE UNDERTAKEN AT THE CONTRACTOR'S EXPENSE.
3. THE CONTRACTOR MUST NOTIFY ALL EXISTING UTILITY COMPANY OFFICIALS FIVE (5) BUSINESS DAYS PRIOR TO THE START OF CONSTRUCTION AND HAVE ALL EXISTING UTILITIES AND SERVICES LOCATED IN THE FIELD OR EXPOSED PRIOR TO THE START OF CONSTRUCTION, INCLUDING BUT NOT LIMITED TO HYDRO, BELL, CABLE, TV, AND CONSUMERS GAS LINES.
4. ALL TRENCHING AND EXCAVATIONS ARE TO BE IN ACCORDANCE WITH THE LATEST REVISIONS OF THE OCCUPATIONAL HEALTH AND SAFETY ACT AND REGULATIONS FOR CONSTRUCTION PROJECTS.
5. REFER TO ARCHITECT PLANS FOR BUILDING DIMENSIONS LAYOUT AND REMOVALS. REFER TO LANDSCAPE PLAN FOR LANDSCAPED DETAILS AND OTHER RELEVANT INFORMATION. THE INFORMATION SHALL BE CONFIRMED PRIOR TO CONSTRUCTION.
6. TOPOGRAPHIC SURVEY COMPLETED ON THE 8TH DAY OF JANUARY 2021 AND PROVIDED BY FARLEY, SMITH & DENIS SURVEYING LTD. CONSTRUCTION TO VERIFY IN THE FIELD PRIOR TO CONSTRUCTION AND NOTIFY THE ENGINEER OF ANY DISCREPANCIES.
7. THE LOCATION OF UNDERGROUND SERVICES IS BASED ON THE SURVEY PROVIDED WITH THE INFORMATION FROM THE CITY OF OTTAWA. HOWEVER, THE CONTRACTOR MUST ENSURE THAT THIS INFORMATION IS VERIFIED PRIOR TO CONSTRUCTION AND NOTIFY THE ENGINEER IMMEDIATELY OF ANY DISCREPANCIES.
8. ALL ELEVATIONS ARE GEODETIC AND UTILIZED METRIC UNITS.
9. JOB BENCHMARK AS INDICATED ON THE DRAWINGS.
10. ALL GROUND SURFACES SHALL BE EVENLY GRADED WITHOUT PONDING AREAS AND WITHOUT LOW POINTS EXCEPT APPROVED SWALE OR CATCH BASIN OUTLETS ARE PROVIDED.
11. ALL EDGES OF THE DISTURBED PAVEMENT SHALL BE SAW CUT TO FORM A NEAT AND STRAIGHT LINE PRIOR TO PLACING NEW PAVEMENT. PAVEMENT REINSTATEMENT SHALL BE WITH STEP JOINTS OF 500MM WIDTH MINIMUM.
12. ALL DISTURBED AREAS OUTSIDE PROPOSED GRADING LIMITS ARE TO BE RESTORED TO ORIGINAL ELEVATIONS AND CONDITIONS UNLESS OTHERWISE SPECIFIED. ALL RESTORATION SHALL BE COMPLETED WITH THE GEOTECHNICAL REQUIREMENTS FOR BACKFILL AND COMPACTION.
13. ALL MATERIAL SUPPLIED AND PLACED FOR PARKING LOT AND ACCESS ROAD CONSTRUCTION SHALL BE TO OPSD STANDARDS AND SPECIFICATIONS UNLESS OTHERWISE NOTED. CONSTRUCTION TO OPSD 206, 310 & 314. MATERIAL TO OPSD 1001, 1003 & 1010.
14. ABUTTING PROPERTY GRADINGS TO BE MATCHED TO STD S14.
15. THE CONTRACTOR SHALL OBTAIN AND PAY FOR ALL NECESSARY PERMITS AND APPROVALS FROM THE MUNICIPAL AUTHORITIES PRIOR TO COMMENCING CONSTRUCTION.
16. MINIMIZE DISTURBANCE TO EXISTING VEGETATION DURING THE EXECUTION OF ALL WORKS.
17. REMOVE FROM THE SITE ALL EXCESS EXCAVATED MATERIAL, UNLESS OTHERWISE DIRECTED FROM THE ENGINEER. EXCAVATE AND REMOVE ALL ORGANIC MATERIAL AND DEBRIS LOCATED WITHIN THE PROPOSED BUILDING, PARKING AND ROADWAY LOCATIONS.
18. ALL PROPOSED UTILITIES CONNECTION POINTS AND CROSSINGS (IE STORM SEWER, SANITARY SEWER, WATER, ETC.) THE CONTRACTOR SHALL DETERMINE THE PRECISE LOCATION AND DEPTH OF EXISTING UTILITIES AND REPORT ANY DISCREPANCIES OR CONFLICTS TO THE ENGINEER BEFORE COMMENCING WORK.
19. SERVICE TRENCHES ON MUNICIPAL RIGHT OF WAY ARE TO BE REINSTATED AS PER CITY OF OTTAWA DETAIL R10.
20. PRIOR TO CONSTRUCTION, A GEOTECHNICAL ENGINEER REGISTERED IN THE PROVINCE OF ONTARIO IS TO INSPECT ALL SUB-SURFACES FOR FOOTINGS, SERVICES AND PAVEMENT STRUCTURES. FOR ANY SOILS RELATED INFORMATION, REFER TO THE GEOTECHNICAL INVESTIGATION REPORT.
21. CONTRACTOR TO REINSTATE PAVEMENT STONES IN CITY ROW.
22. PAVEMENT STRUCTURE SHALL CONSIST OF

Table 5 - Recommended Pavement Structure - Car Only Parking Areas

Thickness (mm)	Material Description
50	Wear Course - HL-3 or Superpave 12.5 Asphaltic Concrete
150	BASE - OPSD Granular A Crushed Stone
300	SUBBASE - OPSD Granular B Type II

Subgrade - Either fill, in-situ soil, or OPSD Granular B Type I or II material placed over in-situ soil, bedrock or concrete fill.

Table 6 - Recommended Pavement Structure - Access Lanes and Heavy Truck Parking Areas

Thickness (mm)	Material Description
40	Wear Course - HL-3 or Superpave 12.5 Asphaltic Concrete
50	Wear Course - HL-8 or Superpave 19 Asphaltic Concrete
150	BASE - OPSD Granular A Crushed Stone
400	SUBBASE - OPSD Granular B Type II

Subgrade - Either fill, in-situ soil, or OPSD Granular B Type I or II material placed over in-situ soil, bedrock or concrete fill.

NOTES WATER MAIN

1. ALL WATER MAIN AND WATER MAIN APPURTENANCES, MATERIALS, CONSTRUCTION AND TESTING METHODS SHALL CONFORM TO THE CURRENT CITY OF OTTAWA AND THE MINISTRY OF ENVIRONMENTAL STANDARDS AND SPECIFICATIONS.
2. ALL WATER MAIN 300MM DIAMETER AND SMALLER TO BE POLYVINYL CHLORIDE (PVC) CLASS 150 OR 18 MEETINGS AWWA SPECIFICATION C900. STANDARD LATERAL MATERIAL SERVICES UP TO 50MM IS COPPER TYPE 'K'.
3. ALL WATER MAINS ARE TO BE INSTALLED AT A MINIMUM COVER OF 2.4M BELOW THE FINISHED GRADE. WHERE WATER MAINS CROSS OTHER UTILITIES, A MINIMUM 0.30m CLEARANCE FROM UTILITIES OVERT SHALL BE MAINTAINED; WHERE WATER MAINS CROSS UNDER OTHER UTILITIES, A MINIMUM OF 0.50m CLEARANCE SHALL BE MAINTAINED. WHERE THE MINIMUM SEPARATION CANNOT BE ACHIEVED, THE WATER MAIN SHALL BE INSTALLED AS PER THE CITY OF OTTAWA STANDARDS W25 AND W25.2. WHERE A 2.4m MINIMUM DEPTH CANNOT BE ACHIEVED, THERMAL INSULATION SHALL BE PROVIDED AS PER THE CITY OF OTTAWA STANDARD W22.
4. WATER MAIN BEDDING TO BE AS PER CITY OF OTTAWA STANDARD W17.
5. VALVE BOX TO BE AS PER CITY OF OTTAWA STANDARD W24.
6. CONCRETE THRUST BLOCKS AND MECHANICAL RESTRAINTS ARE TO BE INSTALLED AT ALL TEES, BENDS, HYDRANTS, REDUCERS, END OF MAINS AND CONNECTIONS 100MM AND LARGER, IN ACCORDANCE WITH THE CITY OF OTTAWA STANDARD W25.3 & W25.4.
7. CATHODIC PROTECTION IS REQUIRED FOR ALL IRON FITTING AS PER THE CITY OF OTTAWA STANDARDS W40 & W42.
8. FIRE HYDRANTS TO BE AS PER CITY OF OTTAWA STANDARD W19. (NOT REQUIRED).
9. THE WATER MAIN MUST BE DEFLECTED TO MEET ALIGNMENT. ENSURE THAT THE AMOUNT OF DEFLECTION USED IS LESS THAN HALF THAT RECOMMENDED BY THE MANUFACTURER. TYPICAL WATER SERVICE LINE AS PER W26 (FOR 19MM & 25MM DIAM WATER SERVICES), AND TO BE INSTALLED AT 1M FROM THE FOUNDATION WALLS.

NOTES: SEWER AND MANHOLES

10. ALL SANITARY SEWER, SANITARY SEWER APPURTENANCES AND CONSTRUCTION METHODS SHALL CONFORM TO THE CURRENT CITY OF OTTAWA STANDARDS AND SPECIFICATIONS.
11. SEWER BEDDING AS PER CITY OF OTTAWA DETAIL S8.
12. ALL WORK SHALL BE PERFORMED AS APPLICABLE IN ACCORDANCE WITH OPSD 407 AND 410.
13. ALL SANITARY MANHOLES 1200mm IN DIAMETER TO BE AS PER OPSD 701.01, FRAME AND COVER TO BE AS PER CITY OF OTTAWA STANDARD S25 AND S24.
14. SANITARY BACKWATER VALVES ARE TO BE PROVIDED FOR EACH BUILDING CLOSE TO THE FOUNDATION WALL NEAR SERVICES ENTRY AS PER CITY OF OTTAWA STD S14.1 OR S14.2.
15. STORM BACKWATER VALVES ARE TO BE PROVIDED CLOSE TO THE FOUNDATION WALL NEAR SERVICES ENTRY AS PER CITY OF OTTAWA STD S14.
16. ALL STORM SEWER MATERIALS AND CONSTRUCTION METHODS SHALL CONFORM TO THE CURRENT CITY OF OTTAWA STANDARDS AND SPECIFICATIONS.
17. Gas main shall be 1.0m of separation from watermain as per R20.

NOTES: EROSION AND SEDIMENT CONTROL

1. CONTRACTOR SHALL IMPLEMENT BEST MANAGEMENT PRACTICES, TO PROVIDE FOR THE PROTECTION OF THE AREA DRAINAGE SYSTEM AND THE RECEIVING WATERCOURSE. DURING CONSTRUCTION ACTIVITIES, THE CONTRACTOR ACKNOWLEDGES THAT FAILURE TO IMPLEMENT EROSION AND SEDIMENT CONTROL MEASURES MAY BE SUBJECT TO PENALTIES IMPOSED BY ANY APPLICABLE REGULATORY AGENCY.



Derrick Clark PEng
EAU Structural & Environmental Svcs
tel., 613 869 0523, derrick.r.clark@rogers.com



2232 rue Saint-Louis,
Gatineau QC J8T 5L6
t: 819.568.3994
c: 613.979.7537
pierretobarchitecte.com

No	DATE	REVISION	App.
1			
2			
3			
4			
5			

No	DATE	ISSUED FOR	App.
1	2022/09/14	SITE PLAN CONTROL	D.K.
2	2022/12/31	PER CITY REVIEW	D.K.
3			
4			
5			

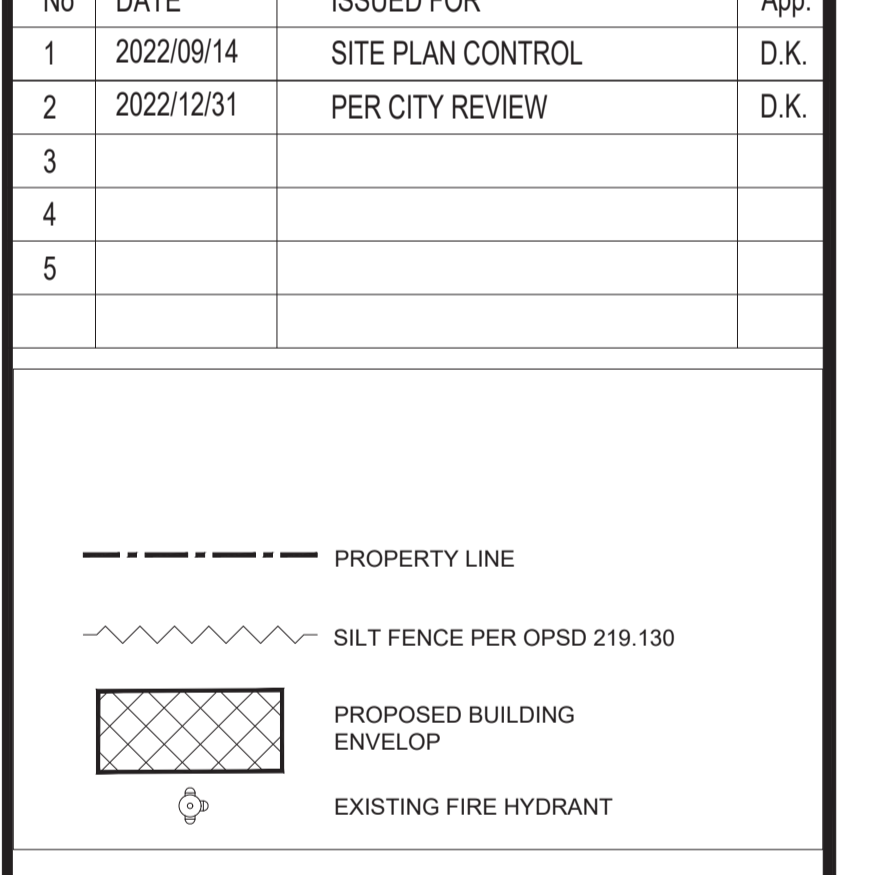

1. MUD MAT IS NOT REQUIRED AT SITE ENTRANCE
2. CB#1, #2 & #3 INLET TO BE PROTECTED WITH GEO-FABRIC.
3. CONCRETE BARRIER CURB PER OPSD 600.110
4. SEWER/STORM LATERAL CONNECTIONS PER OPSD 1006.020 FROM ADJACENT PROPERTY OWNERS FOR WORK OUTSIDE THE PROPERTY LINE.
5. THE CONTRACTOR IS REQUIRED TO GET WRITTEN PERMISSION FROM ADJACENT PROPERTY OWNERS FOR WORK OUTSIDE THE PROPERTY LINE.
6. HEAVY DUTY SILT FENCE PER OPSD 219.136.
7. THE FOLLOWING DOCUMENTS HAVE BEEN REVIEWED
 - CITY OF OTTAWA STANDARD TENDER DOCUMENTS FOR UNIT PRICE (DO-006/10048F1005)
 - GUIDELINES ON EROSION & SEDIMENT CONTROL FOR URBAN SITES, MAY 1987.
 - ENVIRONMENTAL GUIDELINES FOR ACCESS ROADS & WATER CROSSINGS BY O.M.N.R.

Stamp

C1

Project
ORLEANS RESIDENTIAL & MEDICAL FACILITY
3 996 Innes Road, Ottawa, ON.

Title: SITE SERVICING PLAN GRADING PLAN
Scale: 1:200
Date: 2022/09/14
Revision: 0
Drawing #: SS & GR

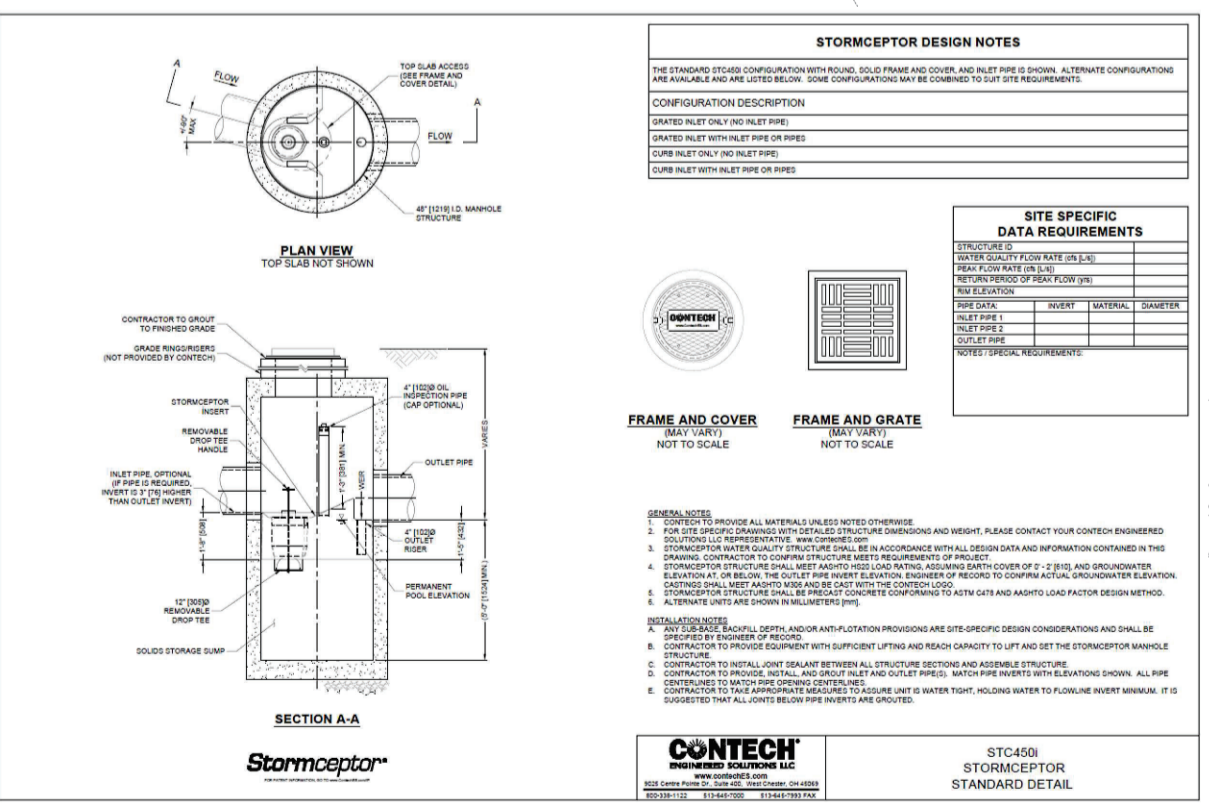

Watermain Table

Watermain Obvert elevation	88.33
Sanitary invert at crossing	88.65
Storm line invert at crossing	88.70
Foundation drain lat at crossing	88.72

Gas line is 0.6 below grad and has no conflict

	Purpose	TOG	Up stream Invert	D/N Stream Invert	Size	OPSD	MH Cover Standard DWG	Top Cover
CB#1	Storm	90.50	-	90.00	600x600	705.010	S19.1	Open
CBMH#2	Storm	90.80	89.80	89.80	1200mm Dia	701.010	S24.1	Closed
CBMH#3	Storm Monitoring MH	90.80	89.58	89.58	1200mm Dia	701.010	S24.1	Closed
CBMH#4	Sanitary Monitoring MH	90.80	88.05	88.05	1200mm Dia	701.010	S24	Closed
Stormceptor STC450i	80% TSSA Removal	90.80	88.02	88.02	1200mm Dia	N/A	S24	Closed

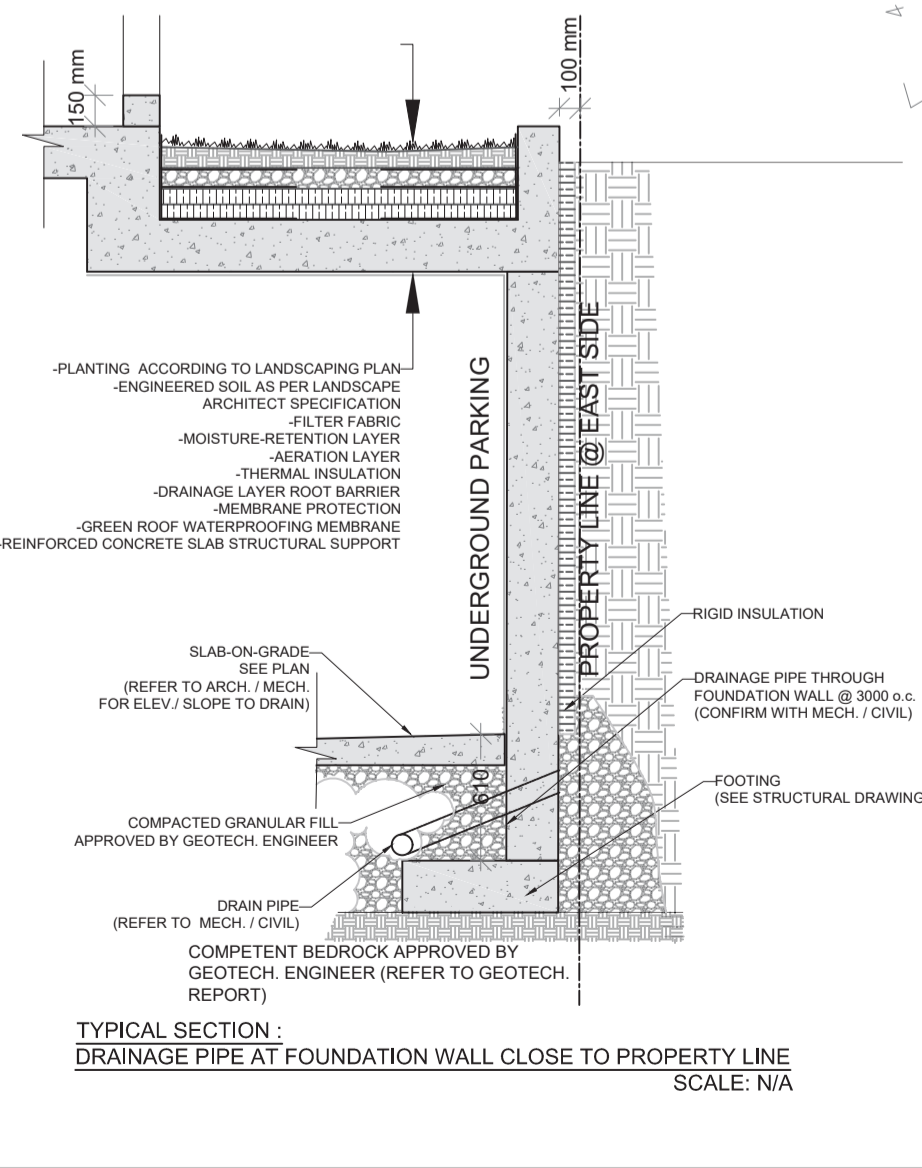

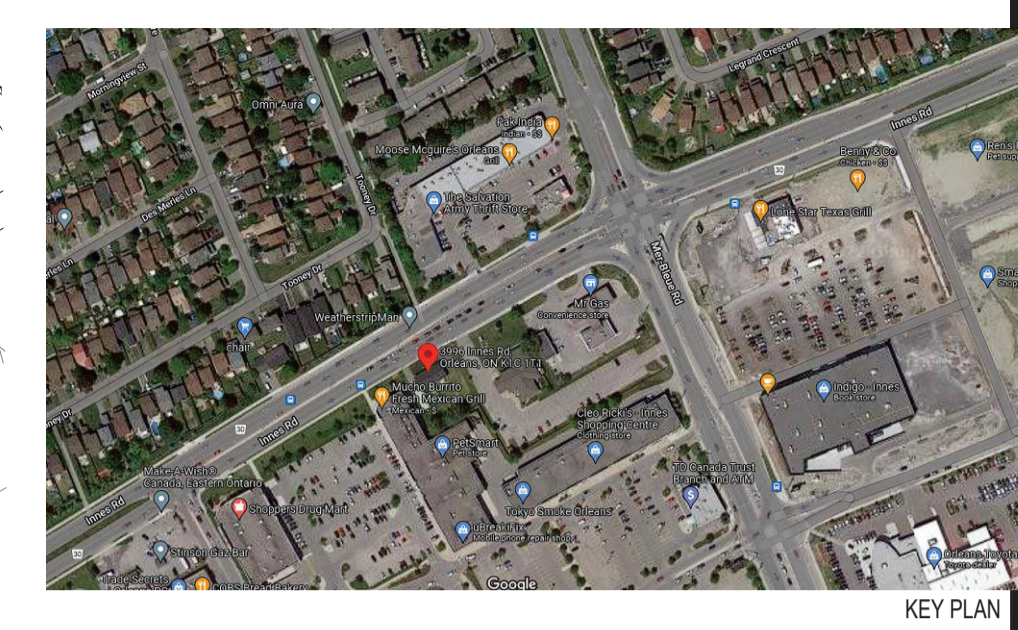
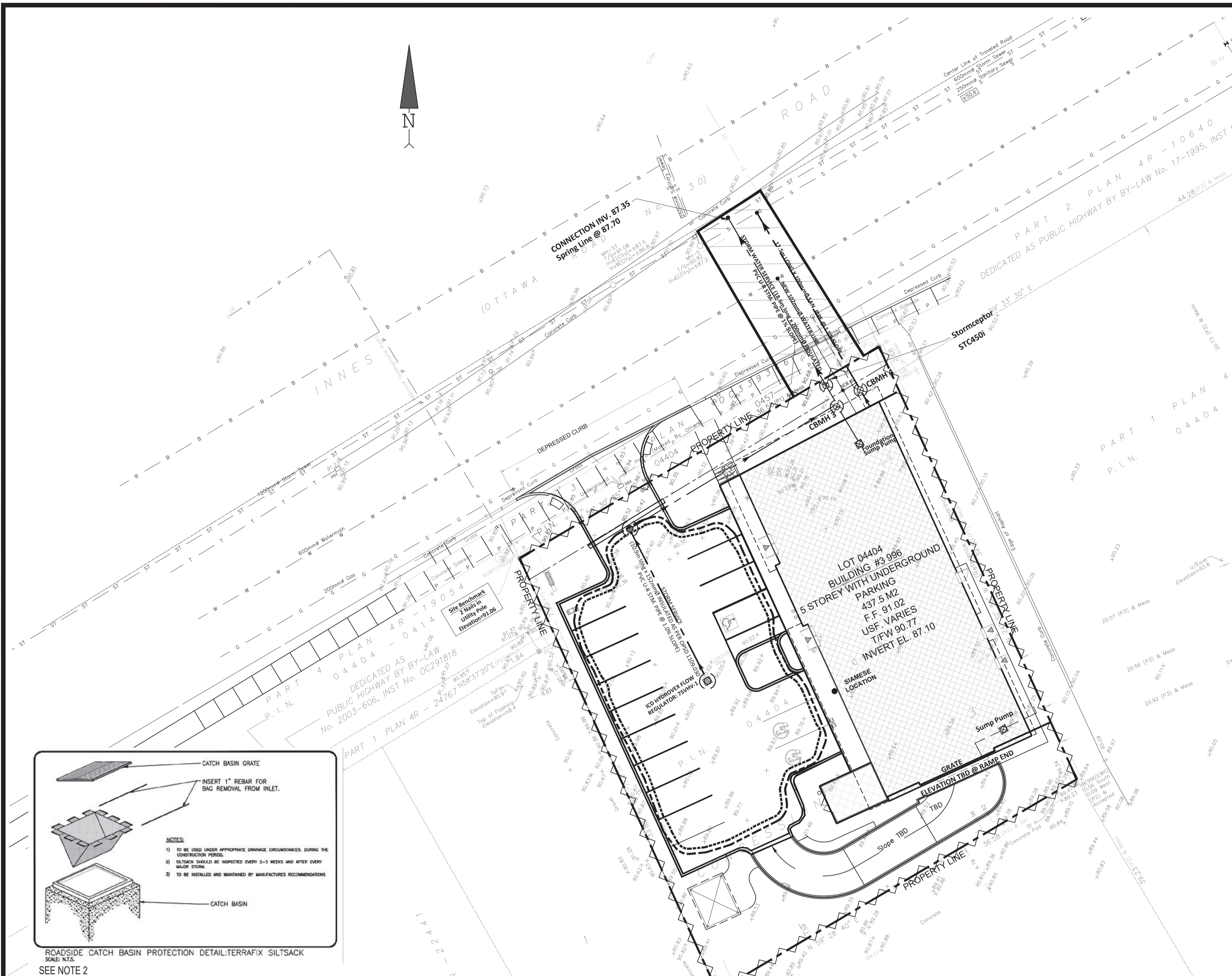

EAU Structural Environmental Services
 Derrick Clark PEng
 EAU Structural & Environmental Svs
 tel., 613 869 0523, derrick.r.clark@rogers.com

Consultants
PTabet architecte
 2232 rue Saint-Louis,
 Gatineau, QC J8T 5L6
 t.: 819.568.3994
 c.: 613.797.9375
 pierretabetarchitecte.com

No	DATE	REVISION	App.
1			
2			
3			
4			
5			

No	DATE	ISSUED FOR	App.
1	2022/09/14	SITE PLAN CONTROL	D.K.
2	2022/12/31	REV PER CITY	D.R.C.
3			
4			
5			

- NOTES & LEGEND:**
- PROPERTY LINE
 - ~~~~ SILT FENCE PER OPSD 219.130
 - [Hatched Box] PROPOSED BUILDING ENVELOP
 - [Circle with X] EXISTING FIRE HYDRANT

- MUD MAT IS NOT REQUIRED AT SITE ENTRANCE
- CB#1, #2 & #3 INLET TO BE PROTECTED WITH GEO-FABRIC.
- CONCRETE BARRIER CURB PER OPSD 600.110
- SEWER/STORM LATERAL CONNECTIONS PER OPSD 1006.020
- THE CONTRACTOR IS REQUIRED TO GET WRITTEN PERMISSION FROM ADJACENT PROPERTY OWNERS FOR WORK OUTSIDE THE PROPERTY LINE.
- HEAVY DUTY SILT FENCE PER OPSD 219.136.
- THE FOLLOWING DOCUMENTS HAVE BEEN REVIEWED
 - CITY OF OTTAWA STANDARD TENDER DOCUMENTS FOR UNIT PRICE (DO-006F-1004&F1005)
 - GUIDELINES ON EROSION & SEDIMENT CONTROL FOR URBAN SITES, MAY 1987.
 - ENVIRONMENTAL GUIDELINES FOR ACCESS ROADS & WATER CROSSINGS BY O.M.N.R.



C2

Project
ORLEANS RESIDENTIAL & MEDICAL FACILITY
 3 996 Innes Road, Ottawa, ON.

Title: **EROSION & SEDIMENT CONTROL PLAN** Drawn / A.F. Scale: 1:200
 Date: 2022/09/14 Revision: 0 Verif. / D.K. Drawing #: ES

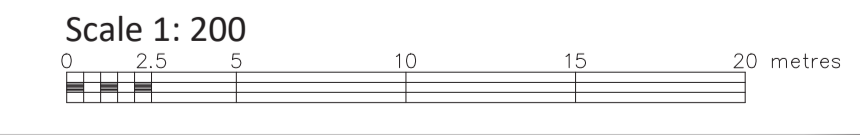
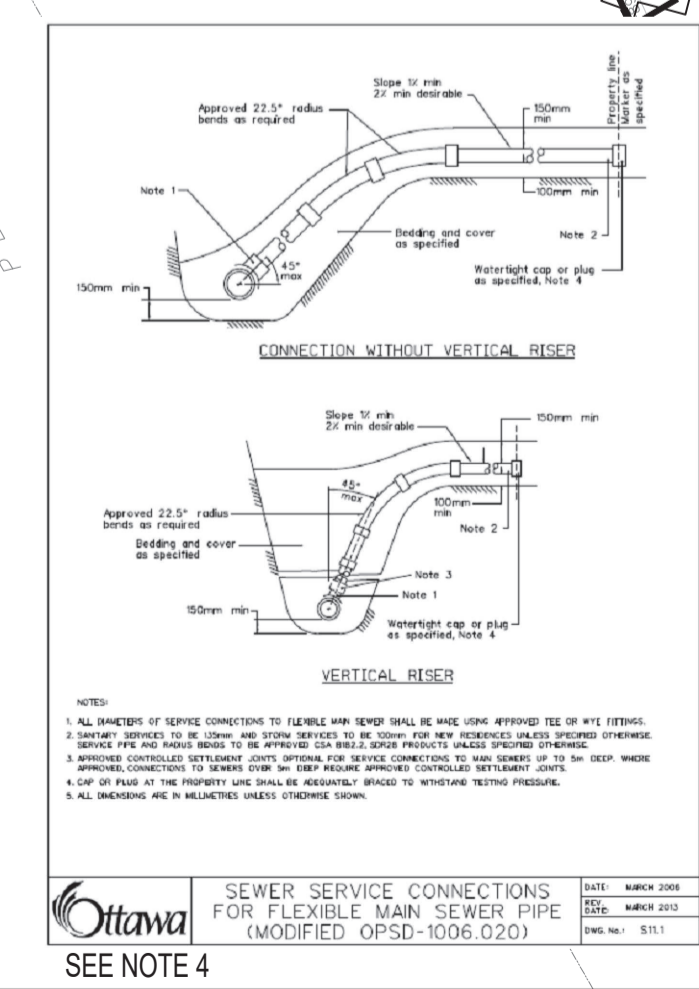
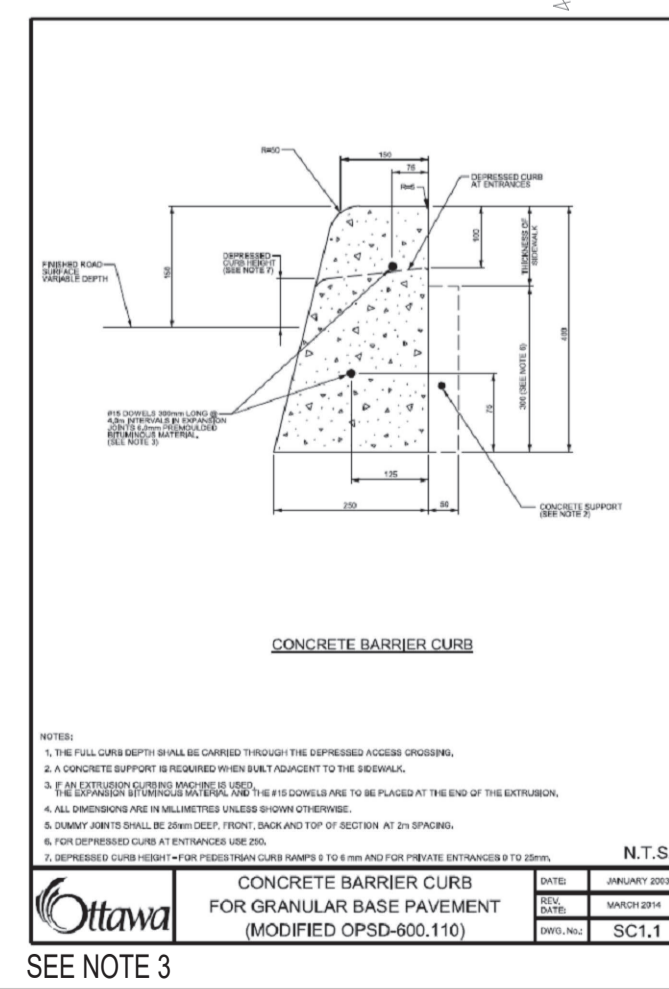
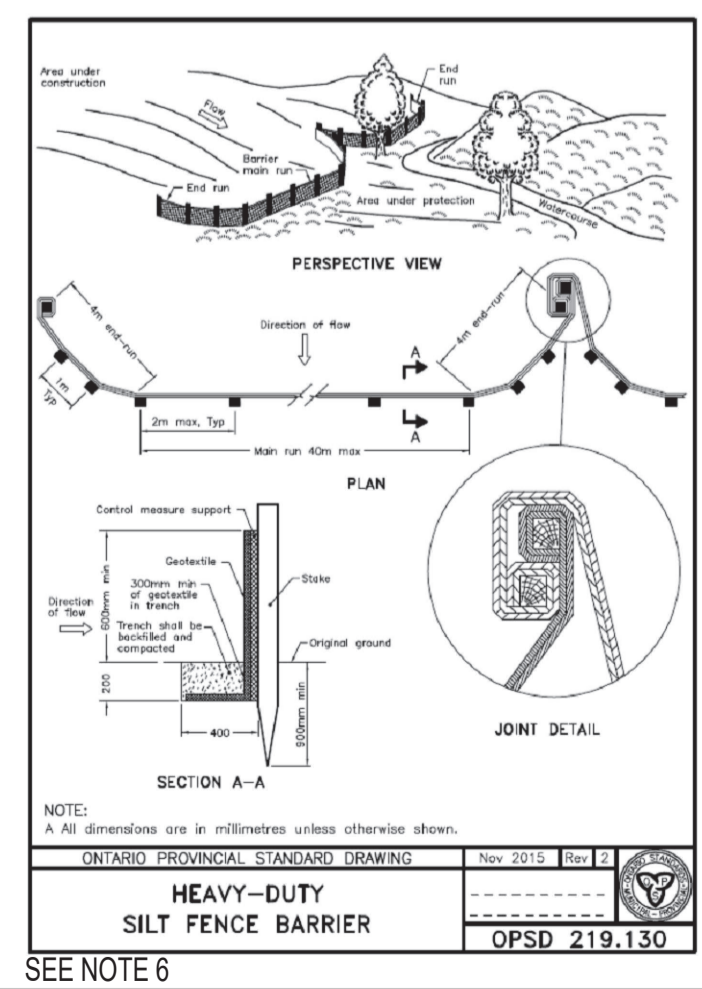
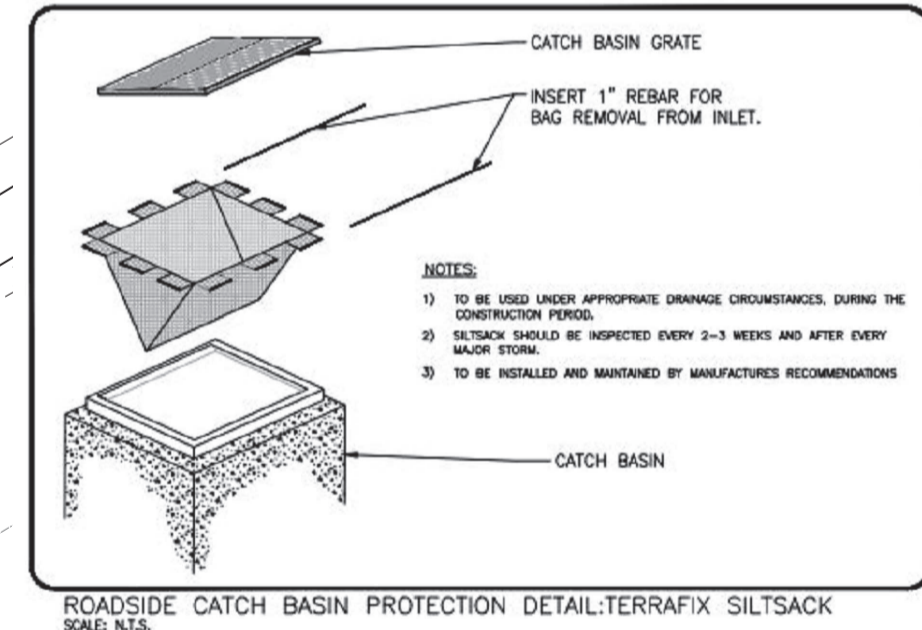

CSO/STORMWATER MANAGEMENT



HYDROVEX[®] VHV / SVHV
Vertical Vortex Flow Regulator

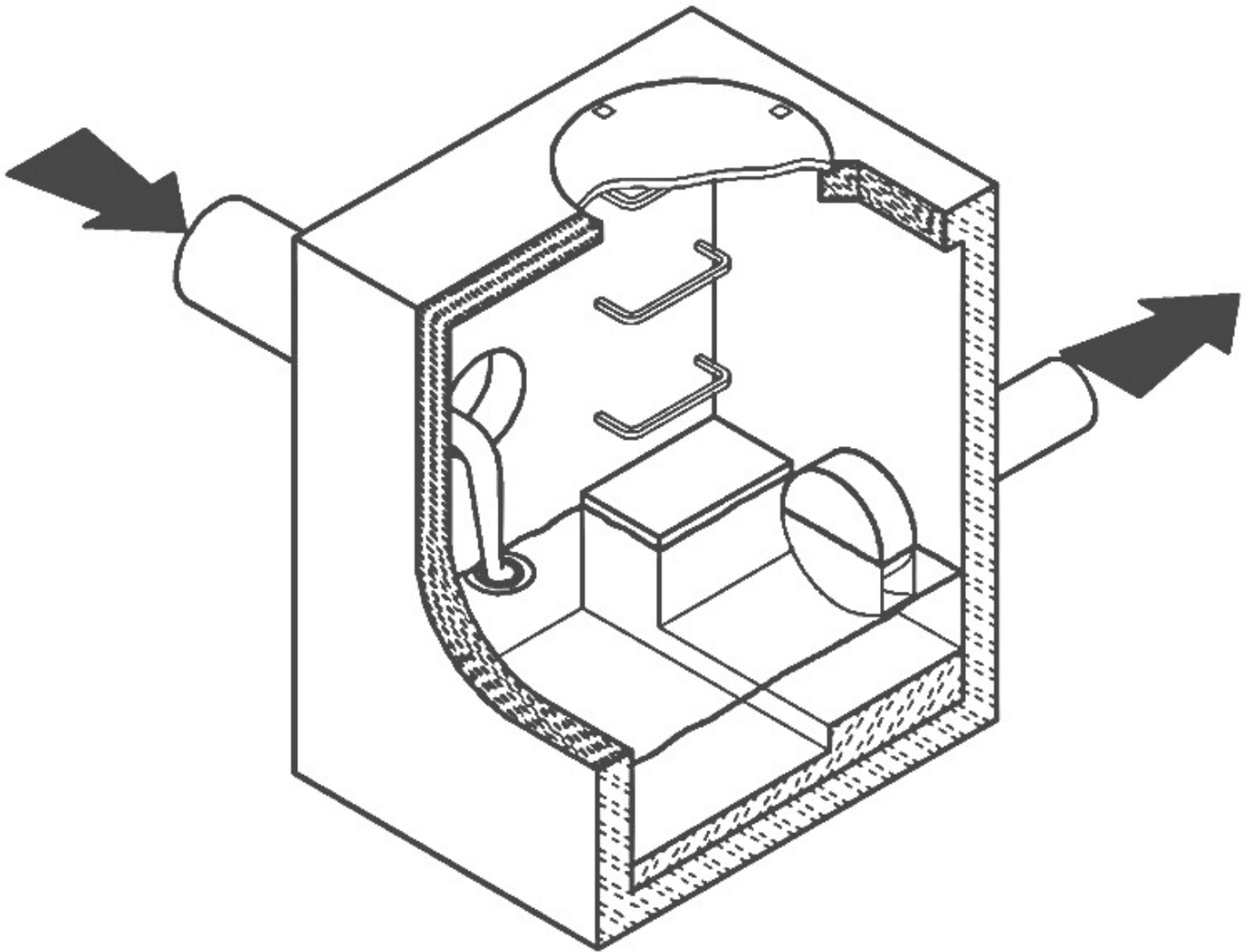

JOHN MEUNIER

HYDROVEX® VHV / SVHV VERTICAL VORTEX FLOW REGULATOR

APPLICATIONS

One of the major problems of urban wet weather flow management is the runoff generated after a heavy rainfall. During a storm event, uncontrolled flows may overload the drainage system and cause flooding. Sewer pipe wear and network deterioration are increased dramatically as a result of increased flow velocities. In a combined sewer system, the wastewater treatment plant will experience a significant increase in flows during storms, thereby losing its treatment efficiency.

A simple means of managing excessive water runoff is to control excessive flows at their point of origin, the manhole. **John Meunier Inc.** manufactures the **HYDROVEX® VHV / SVHV** line of vortex flow regulators for point source control of stormwater flows in sewer networks, as well as manholes, catch basins and other retention structures.

The **HYDROVEX® VHV / SVHV** design is based on the fluid mechanics principle of the forced vortex. The discharge is controlled by an air-filled vortex which reduces the effective water passage area without physically reducing orifice size. This effect grants precise flow regulation without the use of moving parts or electricity, thus minimizing maintenance. Although the concept is quite simple, over 12 years of research and testing have been invested in our vortex technology design in order to optimize its performance.

The **HYDROVEX® VHV / SVHV** Vertical Vortex Flow Regulators (refer to **Figure 1**) are manufactured entirely of stainless steel, and consist of a hollow body (1) (in which flow control takes place) and an outlet orifice (7). Two rubber "O" rings (3) seal and retain the unit inside the outlet pipe. Two stainless steel retaining rings (4) are welded on the outlet sleeve to ensure that there is no shifting of the "O" rings during installation and operation.

1. BODY
2. SLEEVE
3. O-RING
4. RETAINING RINGS
(SQUARE BAR)
5. ANCHOR PLATE
6. INLET
7. OUTLET ORIFICE

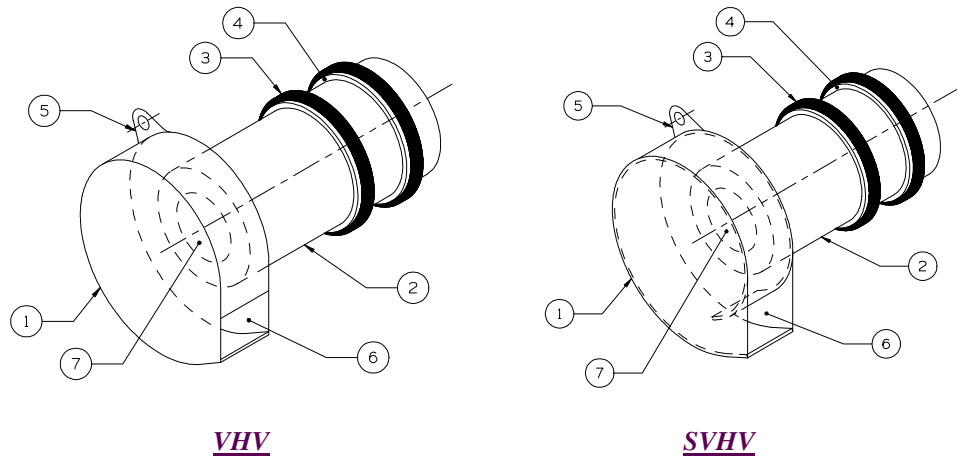

FIGURE 1: HYDROVEX® VHV-SVHV VERTICAL VORTEX FLOW REGULATORS

ADVANTAGES

- As a result of the air-filled vortex, a **HYDROVEX® VHV / SVHV** flow regulator will typically have an opening 4 to 6 times larger than an orifice plate. Larger opening sizes decrease the chance of blockage caused by sediments and debris found in stormwater flows. **Figure 2** shows the discharge curve of a vortex regulator compared to an equally sized orifice plate. One can see that for the same height of water and same opening size, the vortex regulator controls a flow approximately four times smaller than the orifice plate.
- Having no moving parts, they require minimal maintenance.
- Submerged inlet for floatables control.
- The **HYDROVEX® VHV / SVHV** line of flow regulators are manufactured entirely of stainless steel, making them durable and corrosion resistant.
- Installation of the **HYDROVEX® VHV / SVHV** flow regulators is quick and straightforward and is performed after all civil works are completed.
- Installation requires no assembly, special tools or equipment and may be carried out by any contractor.

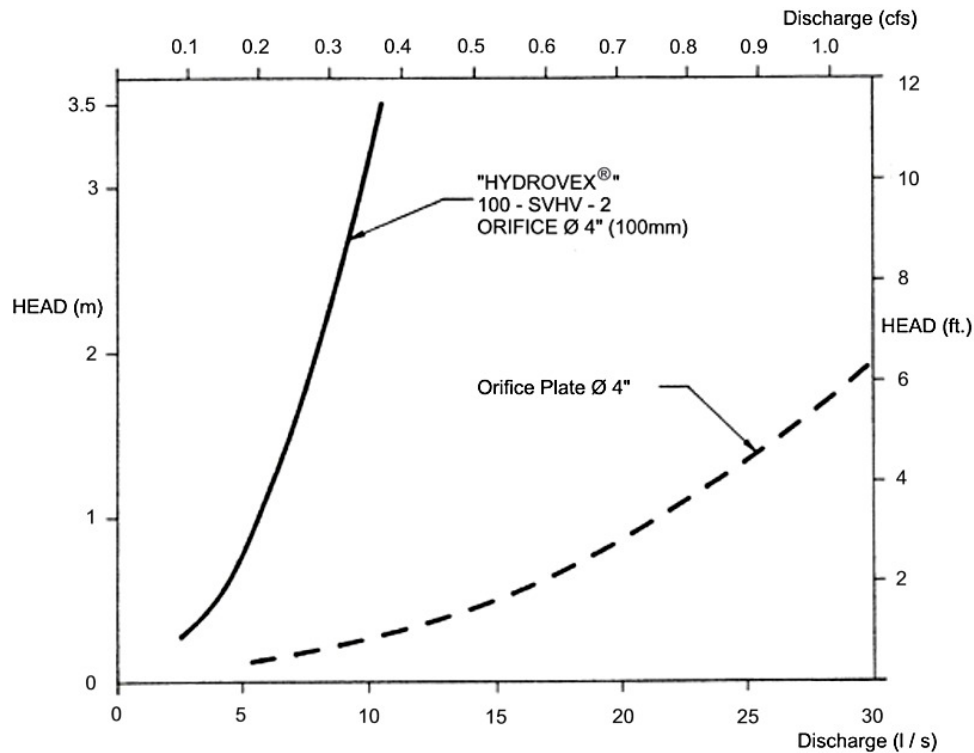

FIGURE 2: DISCHARGE CURVE SHOWING A HYDROVEX® FLOW REGULATOR VS AN ORIFICE PLATE

SELECTION

Selecting a **VHV** or **SVHV** regulator is easily achieved using the selection chart found at the end of this brochure (refer to **Figure 3**). Each selection is made using the maximum allowable discharge rate and the maximum allowable water pressure (head) retained upstream from the regulator. The area in which the design point falls will designate the required VHV/SVHV model. The maximum design head is calculated as the difference between the maximum upstream water level and the invert of the outlet pipe. All selections should be verified by a John Meunier Inc. representative prior to fabrication.

Example:

- ✓ Maximum discharge 6 L/s (0.2 cfs)**
- ✓ Maximum design head 2m (6.56 ft.)
- ✓ Using **Figure 3** model required is a **75 VHV-1**

** It is important to verify the capacity of the manhole/catch basin outlet pipe. Should the outlet pipe be >80% full at design flow, the use of an air vent is required.

INSTALLATION REQUIREMENTS

HYDROVEX® VHV / SVHV flow regulators can be installed in circular or square manholes. **Figure 4** lists the minimum dimensions required for each regulator model. *It is imperative to respect the minimum clearances shown to ensure ease of installation and proper functioning of the regulator.*

SPECIFICATIONS

In order to specify a **HYDROVEX® VHV/SVHV** flow regulator, the following parameters must be clearly indicated:

- The model number (ex: 75-VHV-1)
- The diameter and type of outlet pipe (ex: \varnothing 6", SDR 35)
- The maximum discharge rate (ex: 6.0 L/s [0.21 CFS])
- The maximum upstream head (ex: 2.0 m [6.56 ft]) *
- The manhole diameter (ex: \varnothing 900 mm [\varnothing 36"])
- The minimum clearance "H" (ex: 150 mm [6 in]) as indicated in **Figure 4**
- The material type (ex: 304 stainless steel, standard)

* *Upstream head is defined as the difference in elevation between the maximum upstream water level and the invert of the outlet pipe where the **HYDROVEX®** flow regulator is to be installed.*

PLEASE NOTE THAT WHEN REQUESTING A PROPOSAL, WE SIMPLY REQUIRE THAT YOU PROVIDE US WITH THE FOLLOWING INFORMATION:

- *project design flow rate*
- *pressure head*
- *chamber's outlet pipe diameter and type*



*Typical **HYDROVEX®** VHV model*

OPTIONS



VHV-1-O
(extended inlet for odor control)



FV-VHV
(mounted on sliding plate for emergency bypass)



VHV with Gooseneck assembly
(manhole without clearance below regulator)

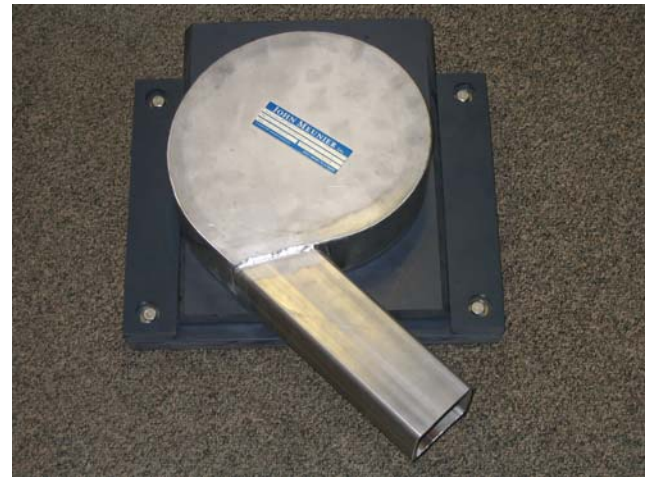

FV-VHV-O
(sliding plate with extended inlet)



VHV with upstream air vent
(applications where outlet pipe is > 80% full at peak flow)



VHV/SVHV Vortex Flow Regulator

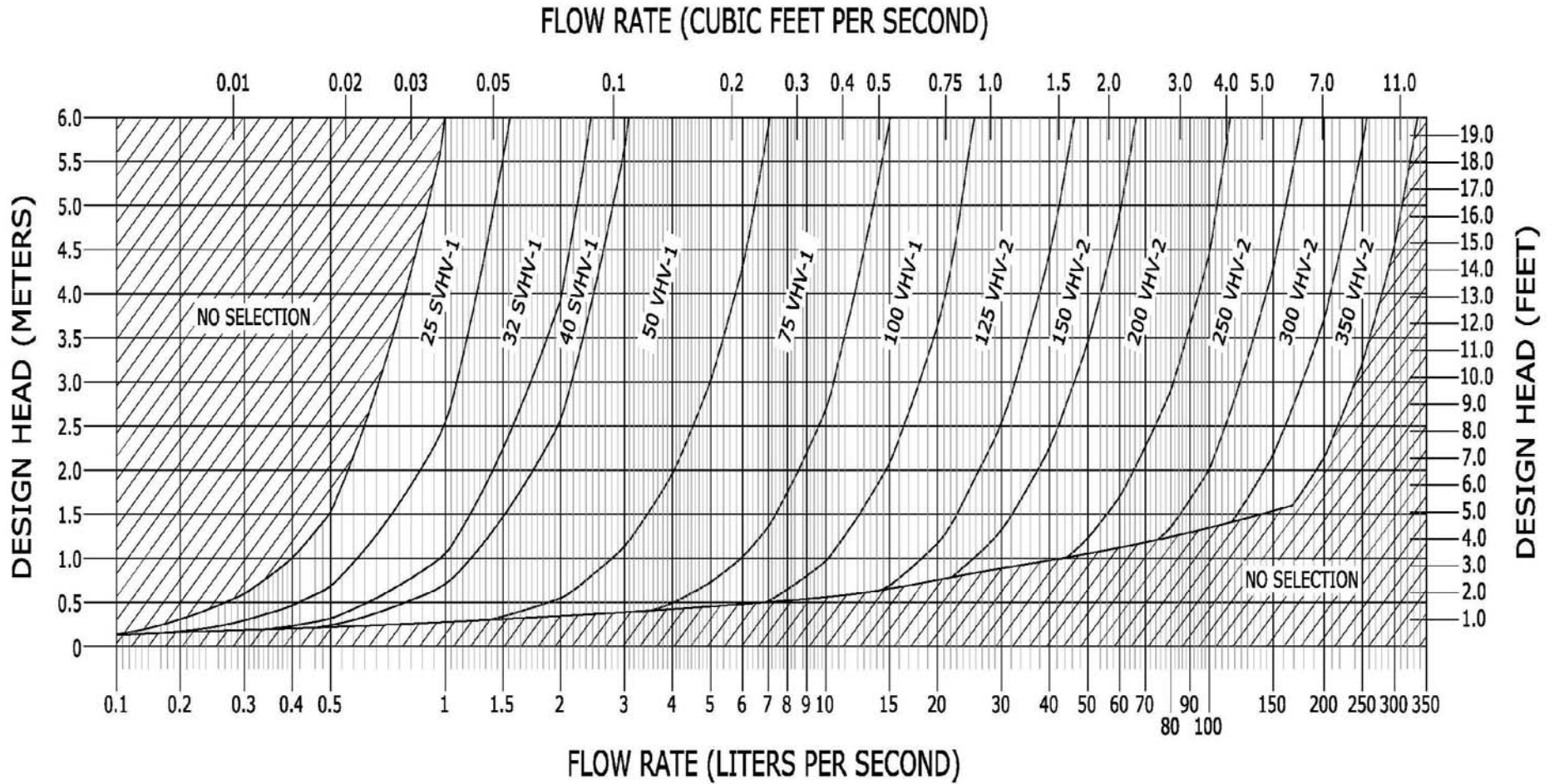

FIGURE 3

JOHN MEUNIER

**TYPICAL INSTALLATION OF A VORTEX FLOW REGULATOR IN
A CIRCULAR OR SQUARE/RECTANGULAR MANHOLE
FIGURE 4**

Model	Regulator Diameter A (mm) [in]	<u>CIRCULAR</u>	<u>SQUARE</u>	Minimum Outlet Pipe Diameter C (mm) [in]	Minimum Clearance H (mm) [in]
		Minimum Manhole Diameter B (mm) [in]	Minimum Chamber Width B (mm) [in]		
25 SVHV-1	125 [5]	600 [24]	600 [24]	150 [6]	150 [6]
32 SVHV-1	150 [6]	600 [24]	600 [24]	150 [6]	150 [6]
40 SVHV-1	200 [8]	600 [24]	600 [24]	150 [6]	150 [6]
50 VHV-1	150 [6]	600 [24]	600 [24]	150 [6]	150 [6]
75 VHV-1	250 [10]	600 [24]	600 [24]	150 [6]	150 [6]
100 VHV-1	325 [13]	900 [36]	600 [24]	150 [6]	200 [8]
125 VHV-2	275 [11]	900 [36]	600 [24]	150 [6]	200 [8]
150 VHV-2	350 [14]	900 [36]	600 [24]	150 [6]	225 [9]
200 VHV-2	450 [18]	1200 [48]	900 [36]	200 [8]	300 [12]
250 VHV-2	575 [23]	1200 [48]	900 [36]	250 [10]	350 [14]
300VHV-2	675 [27]	1600 [64]	1200 [48]	250 [10]	400 [16]
350VHV-2	800 [32]	1800 [72]	1200 [48]	300 [12]	500 [20]

Circular Manhole

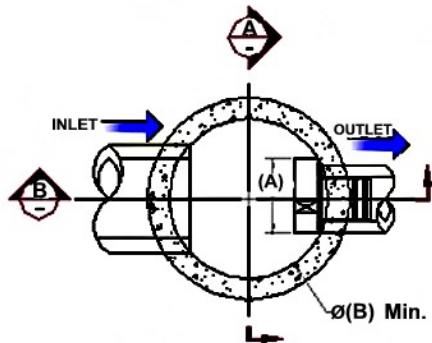

CIRCULAR WELL

Square / Rectangular Manhole

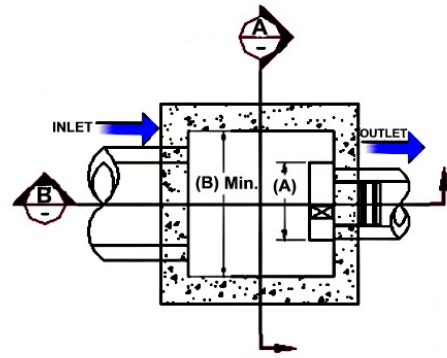

SQUARE / RECTANGULAR WELL

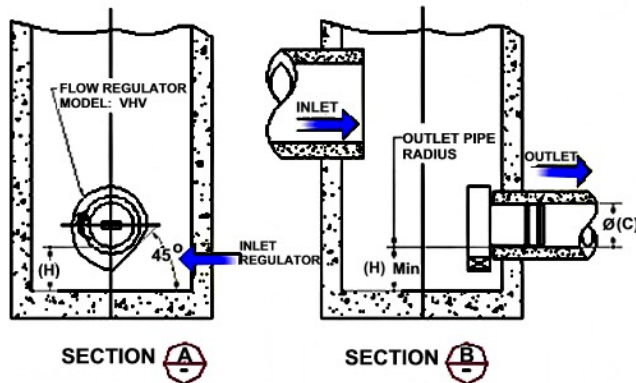

SECTION A-A

SECTION B-B

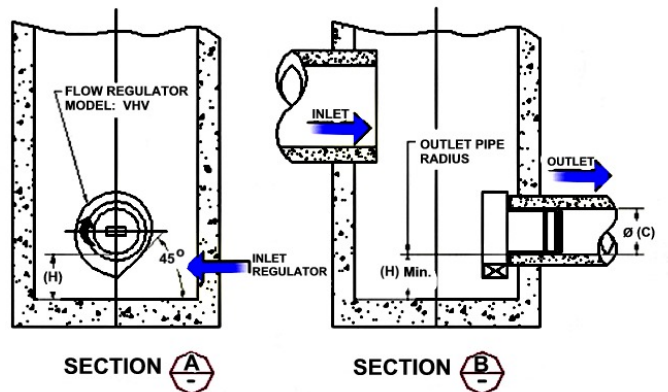

SECTION A-A

SECTION B-B

NOTE: *In the case of a square manhole, the outlet pipe must be centered on the wall to ensure that there is enough clearance for installation of the regulator.*

INSTALLATION

The installation of a **HYDROVEX**[®] regulator may begin once the manhole and piping are in place. Installation consists of simply sliding the regulator into the outlet pipe of the manhole and securing it to the wall with an anchor (supplied). **John Meunier Inc.** recommends applying a lubricant on the inner surface of the outlet pipe, in order to facilitate the insertion and the manipulation of the flow controller.

MAINTENANCE

HYDROVEX[®] regulators are designed and manufactured to minimize maintenance requirements. We recommend a periodic visual inspection every 3-6 months (depending on local flow and sediment conditions) in order to ensure that neither the inlet nor the outlet has become blocked with debris. The manhole housing the vortex regulator should be inspected and cleaned with a vacuum truck periodically, especially after major storm events.

GUARANTY

The **HYDROVEX**[®] line of **VHV / SVHV** regulators are guaranteed against both design and manufacturing defects for a period of 5 years after sale. Should a flow regulator be found to be defective within the guarantee period, **John Meunier Inc.** will modify or replace the defective unit.

John Meunier Inc.

ISO 9001 : 2008

Head Office

4105 Sartelon
Saint-Laurent (Quebec) Canada H4S 2B3
Tel.: 514-334-7230 www.johnmeunier.com
Fax: 514-334-5070 cs@johnmeunier.com

Ontario Office

2000 Argenta Road, Plaza 4, Unit 430
Mississauga (Ontario) Canada L5N 1W1
Tel.: 905-286-4846 www.johnmeunier.com
Fax: 905-286-0488 ontario@johnmeunier.com

USA Office

2209 Menlo Avenue
Glenside, PA USA 19038
Tel.: 412- 417-6614 www.johnmeunier.com
Fax: 215-885-4741 asteele@johnmeunier.com



I:\COMMON\CAD\TREATMENT\23 STORMCEPTOR\40 STANDARD DRAWINGS\IN PROCESS\STC450i-DTL.DWG 2/1/2019 3:12 PM

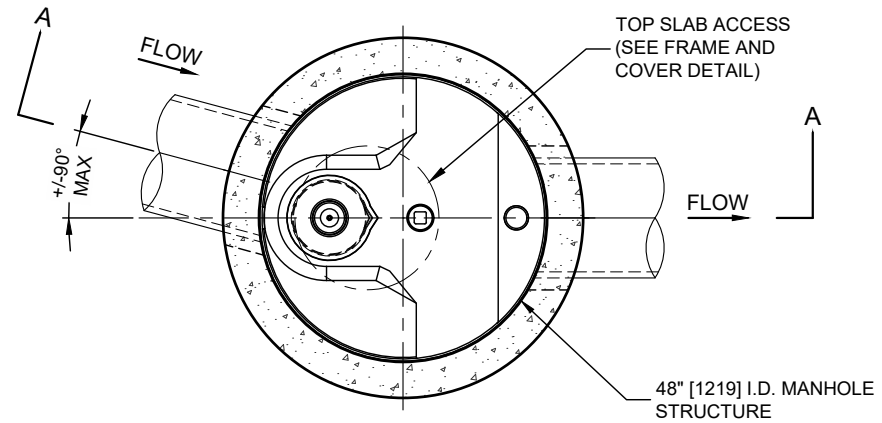

PLAN VIEW
TOP SLAB NOT SHOWN

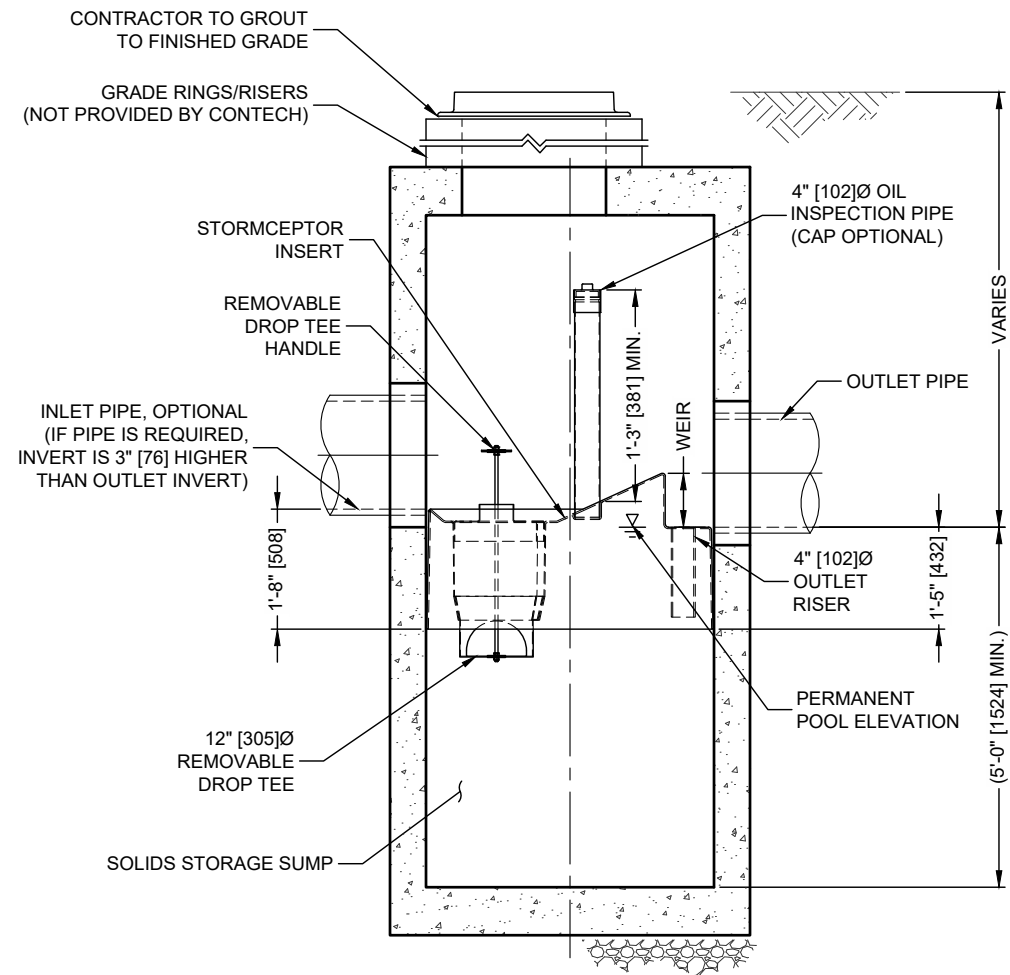

SECTION A-A

Stormceptor

FOR PATENT INFORMATION, GO TO www.contechES.com/IP

STORMCEPTOR DESIGN NOTES

THE STANDARD STC450I CONFIGURATION WITH ROUND, SOLID FRAME AND COVER, AND INLET PIPE IS SHOWN. ALTERNATE CONFIGURATIONS ARE AVAILABLE AND ARE LISTED BELOW. SOME CONFIGURATIONS MAY BE COMBINED TO SUIT SITE REQUIREMENTS.

CONFIGURATION DESCRIPTION

- GRATED INLET ONLY (NO INLET PIPE)
- GRATED INLET WITH INLET PIPE OR PIPES
- CURB INLET ONLY (NO INLET PIPE)
- CURB INLET WITH INLET PIPE OR PIPES

SITE SPECIFIC DATA REQUIREMENTS

STRUCTURE ID			
WATER QUALITY FLOW RATE (cfs [L/s])			
PEAK FLOW RATE (cfs [L/s])			
RETURN PERIOD OF PEAK FLOW (yrs)			
RIM ELEVATION			
PIPE DATA:	INVERT	MATERIAL	DIAMETER
INLET PIPE 1			
INLET PIPE 2			
OUTLET PIPE			

NOTES / SPECIAL REQUIREMENTS:

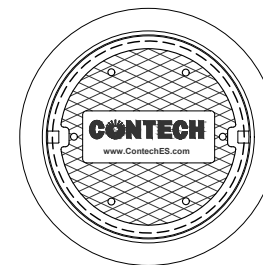

FRAME AND COVER
(MAY VARY)
NOT TO SCALE

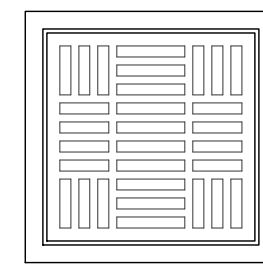

FRAME AND GRATE
(MAY VARY)
NOT TO SCALE

GENERAL NOTES

1. CONTECH TO PROVIDE ALL MATERIALS UNLESS NOTED OTHERWISE.
2. FOR SITE SPECIFIC DRAWINGS WITH DETAILED STRUCTURE DIMENSIONS AND WEIGHT, PLEASE CONTACT YOUR CONTECH ENGINEERED SOLUTIONS LLC REPRESENTATIVE. www.contechES.com
3. STORMCEPTOR WATER QUALITY STRUCTURE SHALL BE IN ACCORDANCE WITH ALL DESIGN DATA AND INFORMATION CONTAINED IN THIS DRAWING. CONTRACTOR TO CONFIRM STRUCTURE MEETS REQUIREMENTS OF PROJECT.
4. STORMCEPTOR STRUCTURE SHALL MEET AASHTO HS20 LOAD RATING, ASSUMING EARTH COVER OF 0' - 2' [610], AND GROUNDWATER ELEVATION AT, OR BELOW, THE OUTLET PIPE INVERT ELEVATION. ENGINEER OF RECORD TO CONFIRM ACTUAL GROUNDWATER ELEVATION. CASTINGS SHALL MEET AASHTO M306 AND BE CAST WITH THE CONTECH LOGO.
5. STORMCEPTOR STRUCTURE SHALL BE PRECAST CONCRETE CONFORMING TO ASTM C478 AND AASHTO LOAD FACTOR DESIGN METHOD.
6. ALTERNATE UNITS ARE SHOWN IN MILLIMETERS [mm].

INSTALLATION NOTES

- A. ANY SUB-BASE, BACKFILL DEPTH, AND/OR ANTI-FLOTATION PROVISIONS ARE SITE-SPECIFIC DESIGN CONSIDERATIONS AND SHALL BE SPECIFIED BY ENGINEER OF RECORD.
- B. CONTRACTOR TO PROVIDE EQUIPMENT WITH SUFFICIENT LIFTING AND REACH CAPACITY TO LIFT AND SET THE STORMCEPTOR MANHOLE STRUCTURE.
- C. CONTRACTOR TO INSTALL JOINT SEALANT BETWEEN ALL STRUCTURE SECTIONS AND ASSEMBLE STRUCTURE.
- D. CONTRACTOR TO PROVIDE, INSTALL, AND GROUT INLET AND OUTLET PIPE(S). MATCH PIPE INVERTS WITH ELEVATIONS SHOWN. ALL PIPE CENTERLINES TO MATCH PIPE OPENING CENTERLINES.
- E. CONTRACTOR TO TAKE APPROPRIATE MEASURES TO ASSURE UNIT IS WATER TIGHT, HOLDING WATER TO FLOWLINE INVERT MINIMUM. IT IS SUGGESTED THAT ALL JOINTS BELOW PIPE INVERTS ARE GROUTED.

CONTECH
ENGINEERED SOLUTIONS LLC

www.contechES.com
9025 Centre Pointe Dr., Suite 400, West Chester, OH 45069
800-338-1122 513-645-7000 513-645-7993 FAX

STC450i
STORMCEPTOR
STANDARD DETAIL