



**Structural
Environmental
Services**

STORMWATER MANAGEMENT REPORT

3996 Innes Road, Ottawa

Prepared by

E AU Structural & Environmental Services

Ottawa, Ontario, K1Y 4P9
Phone: 613 869 0523
Email: derrick.r.clark@rogers.com

Revision 2
March 2023

Table of Contents

- 1. Introduction**
- 2. Stormwater Design.**
- 3. Stormwater Quantity Control**
- 4. Quality Control**
- 5. Foundation/Footing Drain**
- 6. Geotechnical Report Recommendation**
- 7. Best Management Practice**
- 8. Erosion and Sediment Control**
- 9. Conclusion**

Appendixes

Drainage Area

Stormwater management calculation

Engineering Drawings and References

Architectural Drawings

1. Introduction

The property at 3996 Innes Road is located close to intersection of Mer Bleue Road and Innes Rd. The existing lot is 0.15 hectare, currently, contains a one story buildings built in circa 1970. It is proposed that the existing building to be demolished and a new 5-storey commercial/residential building be constructed. Property at 3996 Innes Road is currently zoned as AM (Arterial Mainstreet Zoning) which suits for the purpose of proposed development.

This report will address the servicing requirements associated with the proposed development located at 3996 Innes Road within the City of Ottawa. This report is prepared in response to the request from City of Ottawa Planning department.

1.1. Existing Conditions:

The property measure a total area of approximately 0.15 hectare. The site is fronting 610mm diameter DI water main, 250mm diameter PVC sanitary main and 600mm diameter concrete storm main.

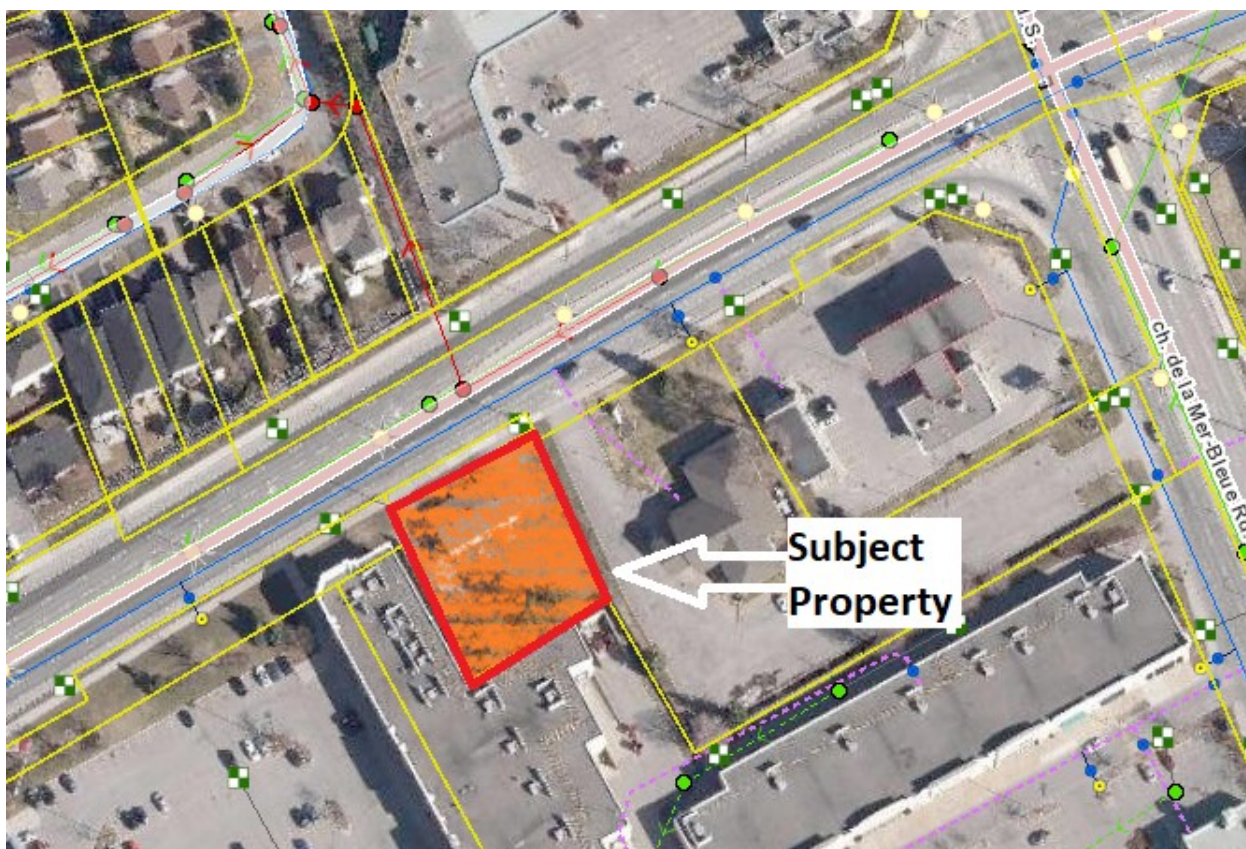

1.2. Guidelines, Previous Studies, And Reports

The following studies were utilized in the preparation of this report:

- Ottawa Sewer Design Guidelines,
City of Ottawa, SDG002, October 2012.
(City Standards)
 - Technical Bulletin ISTB-2018-01
City of Ottawa, March 21, 2018.
(ISTB-2018-01)
 - Technical Bulletin ISTB-2018-04
City of Ottawa, June 27, 2018.
(ISTB-2018-04)

- Ottawa Design Guidelines Water Distribution
City of Ottawa, July 2010.
(Water Supply Guidelines)
 - Technical Bulletin ISD-2010-2
City of Ottawa, December 15, 2010.
(ISD-2010-2)
 - Technical Bulletin ISDTB-2014-02
City of Ottawa, May 27, 2014.
(ISDTB-2014-02)
 - Technical Bulletin ISTB-2018-02
City of Ottawa, March 21, 2018.
(ISTB-2018-02)

- Design Guidelines for Sewage Works,
Ministry of the Environment, 2008.
(MOE Design Guidelines)

- Stormwater Planning and Design Manual,
Ministry of the Environment, March 2003.
(SWMP Design Manual)

- Ontario Building Code Compendium
Ministry of Municipal Affairs and Housing Building Development Branch,
January 1, 2012 Update. (OBC)

- Geotechnical Report
Prepared by Paterson Group
Report Number: PG5925-1
Dated, November 17, 2021

2. Stormwater Design

2.1. Design Criteria

Design of the storm sewer system was completed in conformance with the City of Ottawa Design Guidelines for Sewage Works, Stormwater Management Planning, Design Manual Ontario Ministry of Environment and City of Ottawa Sewer Design Guideline, October 2012.

The site is currently contains a one-storey dwelling. There is no stormwater management on current property. Pre-development conditions will be considered as the lesser of current conditions or conditions resulting in a runoff coefficient of 0.5. Based on the existing ground cover, as show in table below, the pre-development runoff coefficient was considered to be 0.50, which is the C value for grass or vegetation. The 5 year storm event, time of concentration that will be calculated and store up to the 100 years storm event as per direction from the City of Ottawa Planning Department.

Area ID	Area (ha)	Runoff 'C'	A x C
Existing Dwelling	0.05	0.9	0.045
Existing Driveways	0.03	0.9	0.027
Grass or Landscape	0.07	0.1	0.007
Total Site Area (ha)	0.15	---	0.079

Existing C(avg) = 0.53
Therefore Predevelopment C = 0.5

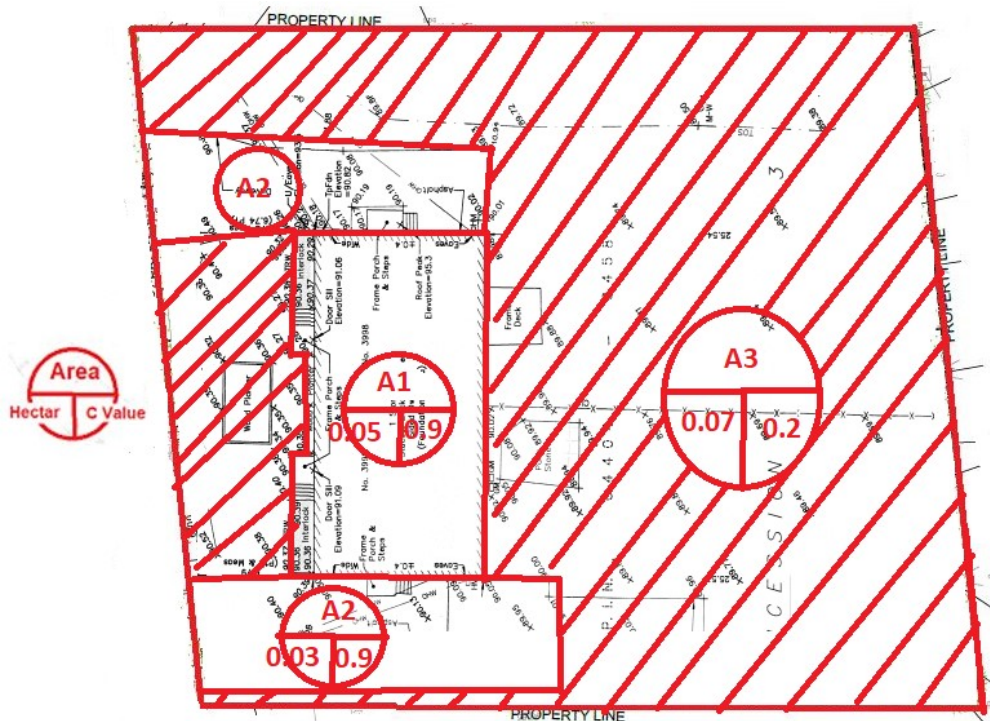

During all construction activities, erosion and sediment shall be controlled by techniques outlined in Section 5 of this report.

2.2. Minor System Design Criteria

- The storm sewers designed based on the rational formula and the Manning's Equation under free flow conditions for the 5-year storm using 10 min time of concentration.
- Inflow rates into the minor system are limited to the pre-development rates for up to the 5-year storm, and are based on a time of concentration of 10 min.
- There is no ponding considered for 2-year storm event.

2.3. Major System Design Criteria

- The major system has been designed to accommodate runoff of 100 year event and above to flow via overland and not to impact adjacent properties.

2.4. Runoff Coefficients

The area for runoff coefficients used for either pre-development or post-development conditions were based on actual areas measured in CAD. Runoff coefficients for surfaces such as roofs, were taken as 0.90, for driveway and parking area were taken as 0.90 due to asphalt used for paving, and for grass area taken as 0.20. Average runoff coefficient for post development is calculated as 0.76 Refer to appendixes for detail.

2.5. Time of concentration

The time of concentration is taken as 10 minutes as per the City of Ottawa Design Guideline.

2.6. Allowable Release Rate

The allowable release rate from the site was determined using the modified rational method with a 5 years storm, a runoff coefficient $C=0.5$, and a time of concentration of 10 minutes as follows;

- Time of Concentration = 10 minutes,
- Drainage Area = 0.15 ha

$$Q_{\text{allow}} = 2.78 C I A$$

Where:

Q allow	=	Allowable release rate to storm sewer (L/sec)
C	=	Runoff Coefficient (dimensionless) =0.5
I	=	Average Rainfall Intensity for return period (mm/hr)
	=	$998.071/(T_C+6.053)^{0.814} = 104.20 \text{ mm/hr}$
T _C	=	Time of concentration (minutes)
A	=	Drainage Area (hectares) = 0.15

$$Q_{\text{Allow}} = 21.72 \text{ L/sec}$$

Therefore the allowable release rate from the site is 21.72 L/sec.

3. Stormwater Quantity Control

Post development storm water management design for this site includes 3 general areas; Grass area, Roof and Driveway area.

- Grass area will sheet drain to the front of the property as per natural drainage pattern.
- Drive way will be working as open storage area for retaining 5yr & 100yr storm event.
- Roof: Storm runoff during 5yrs and 100yrs storm event will be stored in parking and driveway area.

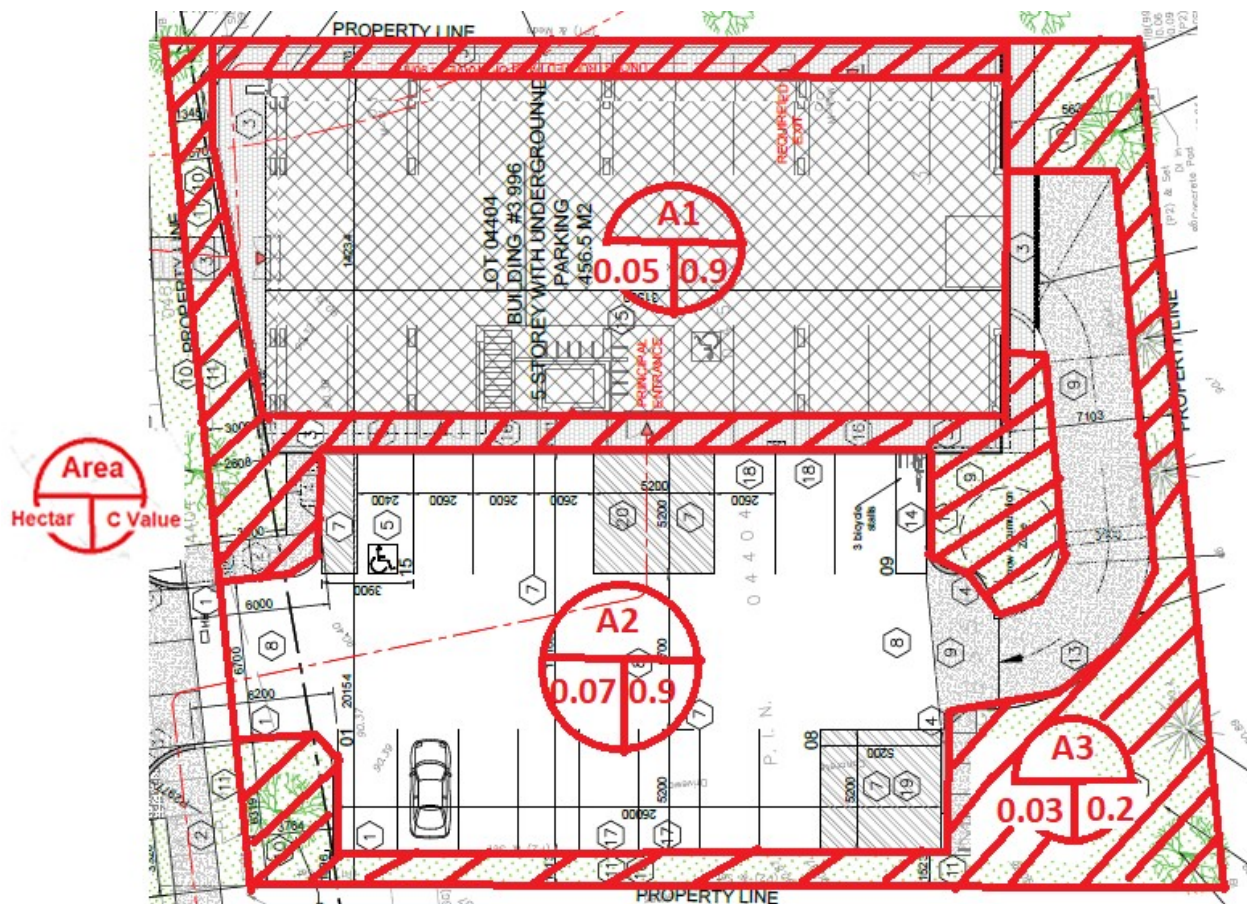

As ponds generally form the shape of a cone, the extend and depth of ponding resulting from the 100-year storm was determined using the following equation;

$$V = \frac{1}{3} \times A \times d$$

Where:

V	=	Storage volume (cu. m.)
A	=	surface area of pond (sq.m.)
D	=	pond depth at peak (m)

Detail of calculation can be found in appendixes. Below is the summary of our calculation:

- Post-development flow rate shall be restricted to pre-development flow rate; 21.72 L/sec refer to section 2.6 for detail. Since the post-development grass area discharge is uncontrolled and discharges as per the natural drainage pattern, the grass discharge rate is deducted from allowable rate that will come up to 21.72 L/s – 1.74 L/s (grass area discharge) = 19.99 L/s. Therefore, post-development release rate will be restricted to 19.99 L/s.
- Based on the calculation, the maximum required storage for 5yr and 100yr storm event is 7.82 m³ and 27.60 m³ respectively.
- 100yr plus 20% due to climate change consideration would bring the required ponding to 33.12 m³
- Side parking area is considered for providing required storage for 5yr and 100yr storm event. Based on maximum ponding height of 150mm, and based on cone formula, available storage will be 35m³ which is satisfactory.

The discharge rate from above connected ponding area will be controlled via ICD which is selected based on Hydrovex flow regulator; 75VHV-1. Refer to appendix for additional information from the manufacturer. Note that the ICD shall be slide type as per the City guidelines. Refer to Grading plan attached this report for additional information.

4. Quality Control

Storm monitoring manhole will be installed inside the property line, prior to discharge to the storm main on Innes road. Also, Stormceptor, EF04 is installed to remove 80% TSSA as per the requirement of the conservation authority. Detail of the calculation and stormceptor model is included in the appendix. Refer to the grading plan for the location of the manholes and appendixes for additional information.

5. Foundation/Footing Drain

Foundation drain is independently connected to storm main on Stewart Street. Please refer to Grading & Drainage plan and Geotechnical Report.

6. Geotechnical Report Recommendation

The Geotechnical report, by Patersongroup Inc., recommends that a perimeter foundation drainage system be provided for the proposed structures. The system should consist of a 100 to

150 mm diameter perforated, corrugated plastic pipe which is surrounded on all sides by 150 mm of 19 mm clear crushed stone and is placed at the footing level around the exterior perimeter of the structure. The pipe should have a positive outlet, such as a gravity connection to the storm sewer.

Waterproofing of the foundation walls may be required if more than one underground level is anticipated. Due to the lack of bedrock coring, the groundwater table depth was not accurately measure below the bedrock surface. However, based on the current information, waterproofing is not anticipated to be required if one underground level is being considered. The requirement for waterproofing should be confirmed by Paterson upon commencement of excavation when the groundwater infiltration can be better assessed.

All other Geotechnical recommendation shall be implemented on its entire context.

7. Best Management Practice for Low Impact Development

As for stormwater filter and infiltration practice, grass area acts as primary bio-filter. Dense grass or vegetation area acts as better bio-filter. The topsoil is also a primary filtration prior to the rainwater absorbent. Increasing topsoil by a few centimeter would considerably increase the capacity of soil filtration. For this development, minimum topsoil of 150mm is considered for any proposed grass area.

8. Erosion and Sediment Control

Following methods will be unutilized to control erosion and sediment:

- Silt fence will be installed around the perimeter of the site and will be cleaned and maintained throughout construction. Silt fence will remain in place until the working areas have been stabilized and re-vegetated.
- Catch basins will have GEO-Fabric or an approved equivalent installed under and over the grate during construction to protect from silt entering the storm sewer system.
- A mud mat will be installed at the construction access in order to prevent mud tracking onto adjacent roads.
- Erosion and sediment controls must be in place during construction. The following recommendations to the contractor will be included in contract documents:
 - Limit extent of exposed soils at any given time;
 - Re-vegetate exposed areas as soon as possible;
 - Minimize the area to be cleared and grubbed;
 - Protect exposed slopes with plastic or synthetic mulches;
 - Install silt fence to prevent sediment from entering existing ditches;
 - No refueling or cleaning of equipment near existing watercourses;
 - Provide sediment traps and basins during dewatering;
 - Install filter cloth between catch basins and frames;
 - Plan construction at proper time to avoid flooding;

- Establish material stockpiles away from watercourses, so that barriers and filters may be installed.
- The contractor will, at every rainfall, complete inspections and guarantee proper performance. The inspection is to include:
 - Verification that water is not flowing under silt barriers;
 - Clean and change filter cloth at catch basins.
- Construction and maintenance requirements for erosion and sediment controls to comply with Ontario Provincial Standard Specification OPSS 577, and City of Ottawa specifications.
- A visual inspection shall be completed daily on sediment control barriers and any damage repaired immediately. Care will be taken to prevent damage during construction operations.
- Proposed CBs are to have erosion protection as identified within the stormwater management report. The maintenance of the CB erosion protection shall be regular inspections and debris removal as required.
- Refer to Erosion and Sediment control plan in appendix for more detail.

9. Conclusions

This report addresses the storm water management of the proposed site. The following list below itemizes the conclusions of this report.

- The allowable release rate for the site and required storage volume for 5year and 100year storm event calculated.
- Runoff from the roof and parking area will be retained in the parking and driveway area then discharged to the City storm system via an ICD
- During all construction activities, erosion and sedimentation shall be controlled be techniques outlined in this report.

Should you have any question, do not hesitate to let us know.



Derrick R. Clark, PEng.
EAU Structural & Environmental Services
Telephone: (613) 869 0523
derrick.r.clark@rogers.com

APPENDIX A:

Storm Drain Area

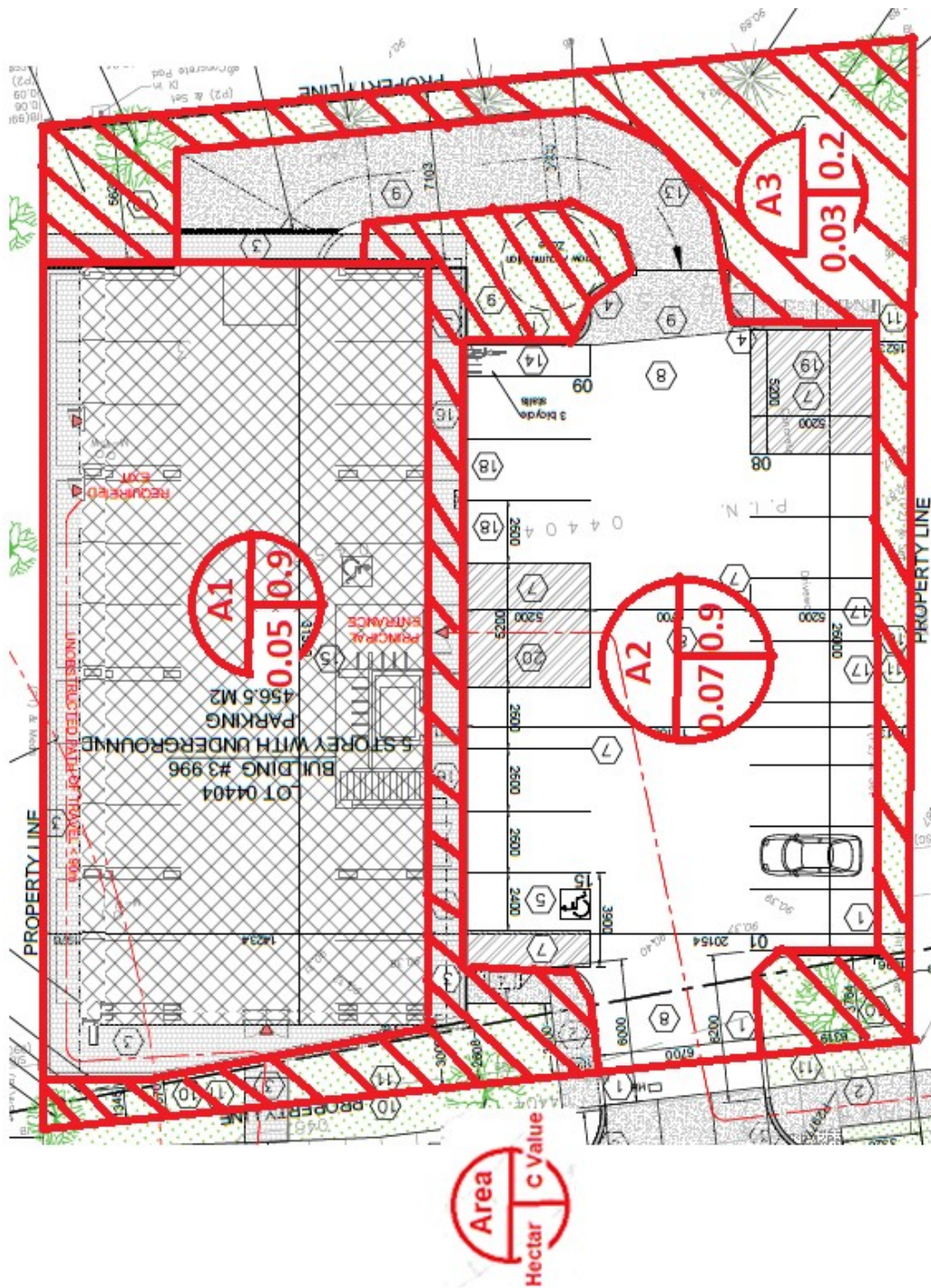

APPENDIX B:

Stormwater Management Calculation

C(max equiv)	I (mm/h)	Area (ha)	Q(allow)
0.5	104.2	0.150	21.72 L/s
C (Un-controlled)			
0.2	104.2	0.030	1.74 L/s
Q(allow)			19.99 L/s

Area ID	Area (ha)	C (5yr)	A x C	C (100yr) (Max of 1.0)	A x C	Type of Flow (Controlled/Uncontrolled)
A1: Proposed Building	0.050	0.9	0.05	1.00	0.05	Controlled
A2: Parking area	0.070	0.9	0.06	1.00	0.07	Controlled
A3: Grass area	0.030	0.2	0.01	0.25	0.01	Un-controlled
Total Site Area (ha)	0.15	---	0.11	---	0.13	Total

C(avg) 5-year = 0.76
 C(avg) 100-year = 0.85

STORAGE CALCULATIONS

C(5 gr)	C(100 gr)	Area (ha)
0.76	0.85	0.150

Q(restricted) l/s = 19.99

t(c)min	I(mm/h)	Q(unrestricted) l/s	Q(restricted) l/s	Q(stored) l/s	V(stored) m ³
5	141.2	44.74	19.99	24.76	7.43
10	104.2	33.02	19.99	13.03	7.82
15	83.6	26.48	19.99	6.49	5.85
20	70.3	22.26	19.99	2.28	2.73
25	60.9	19.30	19.99	-0.69	-1.03
30	53.9	17.09	19.99	-2.90	-5.21
35	48.5	15.38	19.99	-4.61	-9.68
40	44.2	14.00	19.99	-5.98	-14.36
45	40.6	12.88	19.99	-7.11	-19.20
50	37.7	11.93	19.99	-8.05	-24.16
55	35.1	11.13	19.99	-8.86	-29.22
60	32.9	10.44	19.99	-9.55	-34.37
65	31.0	9.84	19.99	-10.15	-39.58
70	29.4	9.31	19.99	-10.68	-44.85
75	27.9	8.84	19.99	-11.15	-50.17
80	26.6	8.42	19.99	-11.57	-55.53
85	25.4	8.04	19.99	-11.95	-60.93
90	24.3	7.70	19.99	-12.29	-66.36
95	23.3	7.39	19.99	-12.60	-71.82
100	22.4	7.10	19.99	-12.89	-77.31
105	21.6	6.84	19.99	-13.15	-82.82
110	20.8	6.60	19.99	-13.39	-88.36

Max Vol stored 7.82

STORAGE TABLE (100 Yr Storm)

t(c)min	I(100yr) mm/h	Q(actual) l/s	Q(restricted) l/s	Q(stored) l/s	V(stored) m ³
5	242.7	86.0	20.0	66.0	19.81
10	178.6	63.3	20.0	43.3	25.98
15	142.9	50.6	20.0	30.7	27.60
20	120.0	42.5	20.0	22.5	27.04
25	103.8	36.8	20.0	16.8	25.23
30	91.9	32.6	20.0	12.6	22.64
35	82.6	29.3	20.0	9.3	19.50
40	75.1	26.6	20.0	6.6	15.96
45	69.1	24.5	20.0	4.5	12.12
50	64.0	22.7	20.0	2.7	8.05
55	59.6	21.1	20.0	1.1	3.79
60	55.9	19.8	20.0	-0.2	-0.63
65	52.6	18.7	20.0	-1.3	-5.17
70	49.8	17.6	20.0	-2.3	-9.82
75	47.3	16.7	20.0	-3.2	-14.56
80	45.0	15.9	20.0	-4.0	-19.39
85	43.0	15.2	20.0	-4.8	-24.28
90	41.1	14.6	20.0	-5.4	-29.24
95	39.4	14.0	20.0	-6.0	-34.25
100	37.9	13.4	20.0	-6.6	-39.31
105	36.5	12.9	20.0	-7.0	-44.41
110	35.2	12.5	20.0	-7.5	-49.56

Max Vol stored 27.60

APPENDIX C:
Specifications and Drawings

Stormceptor® EF Sizing Report

STORMCEPTOR® ESTIMATED NET ANNUAL SEDIMENT (TSS) LOAD REDUCTION

04/05/2023

Province:	Ontario
City:	Ottawa
Nearest Rainfall Station:	OTTAWA CDA RCS
Climate Station Id:	6105978
Years of Rainfall Data:	20

Project Name:	Orleans Residential & Medical
Project Number:	0209
Designer Name:	Bob Ross
Designer Company:	Eau Services
Designer Email:	eau.services.ottawa@gmail.com
Designer Phone:	613-299-7689
EOR Name:	
EOR Company:	
EOR Email:	
EOR Phone:	

Site Name:	Orleans Residential & Medical
Drainage Area (ha):	0.15
Runoff Coefficient 'c':	0.76
Particle Size Distribution:	Fine
Target TSS Removal (%):	80.0

Required Water Quality Runoff Volume Capture (%):	90.00
Estimated Water Quality Flow Rate (L/s):	3.68
Oil / Fuel Spill Risk Site?	Yes
Upstream Flow Control?	No
Peak Conveyance (maximum) Flow Rate (L/s):	19.99
Site Sediment Transport Rate (kg/ha/yr):	480.00
Estimated Average Annual Sediment Load (kg/yr):	54.72

Net Annual Sediment (TSS) Load Reduction Sizing Summary	
Stormceptor Model	TSS Removal Provided (%)
EFO4	96
EFO6	99
EFO8	100
EFO10	100
EFO12	100

Recommended Stormceptor EFO Model: EFO4
Estimated Net Annual Sediment (TSS) Load Reduction (%): 96
Water Quality Runoff Volume Capture (%): > 90

Stormceptor® EF Sizing Report

THIRD-PARTY TESTING AND VERIFICATION

► **Stormceptor® EF and Stormceptor® EFO** are the latest evolutions in the Stormceptor® oil-grit separator (OGS) technology series, and are designed to remove a wide variety of pollutants from stormwater and snowmelt runoff. These technologies have been third-party tested in accordance with the Canadian ETV **Procedure for Laboratory Testing of Oil-Grit Separators** and performance has been third-party verified in accordance with the **ISO 14034 Environmental Technology Verification (ETV)** protocol.

PERFORMANCE

► **Stormceptor® EF and EFO** remove stormwater pollutants through gravity separation and floatation, and feature a patent-pending design that generates positive removal of total suspended solids (TSS) throughout each storm event, including high-intensity storms. Captured pollutants include sediment, free oils, and sediment-bound pollutants such as nutrients, heavy metals, and petroleum hydrocarbons. Stormceptor is sized to remove a high level of TSS from the frequent rainfall events that contribute the vast majority of annual runoff volume and pollutant load. The technology incorporates an internal bypass to convey excessive stormwater flows from high-intensity storms through the device without resuspension and washout (scour) of previously captured pollutants. Proper routine maintenance ensures high pollutant removal performance and protection of downstream waterways.

PARTICLE SIZE DISTRIBUTION (PSD)

► The **Canadian ETV PSD** shown in the table below was used, or in part, for this sizing. This is the identical PSD that is referenced in the Canadian ETV **Procedure for Laboratory Testing of Oil-Grit Separators** for both sediment removal testing and scour testing. The Canadian ETV PSD contains a wide range of particle sizes in the sand and silt fractions, and is considered reasonably representative of the particle size fractions found in typical urban stormwater runoff.

Particle Size (µm)	Percent Less Than	Particle Size Fraction (µm)	Percent
1000	100	500-1000	5
500	95	250-500	5
250	90	150-250	15
150	75	100-150	15
100	60	75-100	10
75	50	50-75	5
50	45	20-50	10
20	35	8-20	15
8	20	5-8	10
5	10	2-5	5
2	5	<2	5

Stormceptor[®] EF Sizing Report

Rainfall Intensity (mm / hr)	Percent Rainfall Volume (%)	Cumulative Rainfall Volume (%)	Flow Rate (L/s)	Flow Rate (L/min)	Surface Loading Rate (L/min/m ²)	Removal Efficiency (%)	Incremental Removal (%)	Cumulative Removal (%)
0.5	8.6	8.6	0.16	10.0	8.0	100	8.6	8.6
1	20.3	29.0	0.32	19.0	16.0	100	20.3	29.0
2	16.2	45.2	0.63	38.0	32.0	100	16.2	45.2
3	12.0	57.2	0.95	57.0	48.0	100	12.0	57.2
4	8.4	65.6	1.27	76.0	63.0	100	8.4	65.6
5	5.9	71.6	1.58	95.0	79.0	98	5.9	71.5
6	4.6	76.2	1.90	114.0	95.0	97	4.5	76.0
7	3.1	79.3	2.22	133.0	111.0	95	2.9	78.9
8	2.7	82.0	2.54	152.0	127.0	93	2.6	81.4
9	3.3	85.3	2.85	171.0	143.0	91	3.0	84.5
10	2.3	87.6	3.17	190.0	158.0	89	2.1	86.5
11	1.6	89.2	3.49	209.0	174.0	87	1.4	87.9
12	1.3	90.5	3.80	228.0	190.0	84	1.1	89.0
13	1.7	92.2	4.12	247.0	206.0	83	1.4	90.4
14	1.2	93.5	4.44	266.0	222.0	82	1.0	91.4
15	1.2	94.6	4.75	285.0	238.0	82	0.9	92.4
16	0.7	95.3	5.07	304.0	254.0	81	0.6	92.9
17	0.7	96.1	5.39	323.0	269.0	80	0.6	93.5
18	0.4	96.5	5.70	342.0	285.0	79	0.3	93.8
19	0.4	96.9	6.02	361.0	301.0	78	0.3	94.2
20	0.2	97.1	6.34	380.0	317.0	78	0.2	94.3
21	0.5	97.5	6.66	399.0	333.0	77	0.4	94.7
22	0.2	97.8	6.97	418.0	349.0	77	0.2	94.9
23	1.0	98.8	7.29	437.0	364.0	76	0.8	95.6
24	0.3	99.1	7.61	456.0	380.0	75	0.2	95.8
25	0.0	99.1	7.92	475.0	396.0	74	0.0	95.8
30	0.9	100.0	9.51	570.0	475.0	71	0.7	96.5
35	0.0	100.0	11.09	666.0	555.0	67	0.0	96.5
40	0.0	100.0	12.68	761.0	634.0	64	0.0	96.5
45	0.0	100.0	14.26	856.0	713.0	64	0.0	96.5
Estimated Net Annual Sediment (TSS) Load Reduction =								96 %

Climate Station ID: 6105978 Years of Rainfall Data: 20



Stormceptor® EF Sizing Report

RAINFALL DATA FROM OTTAWA CDA RCS RAINFALL STATION

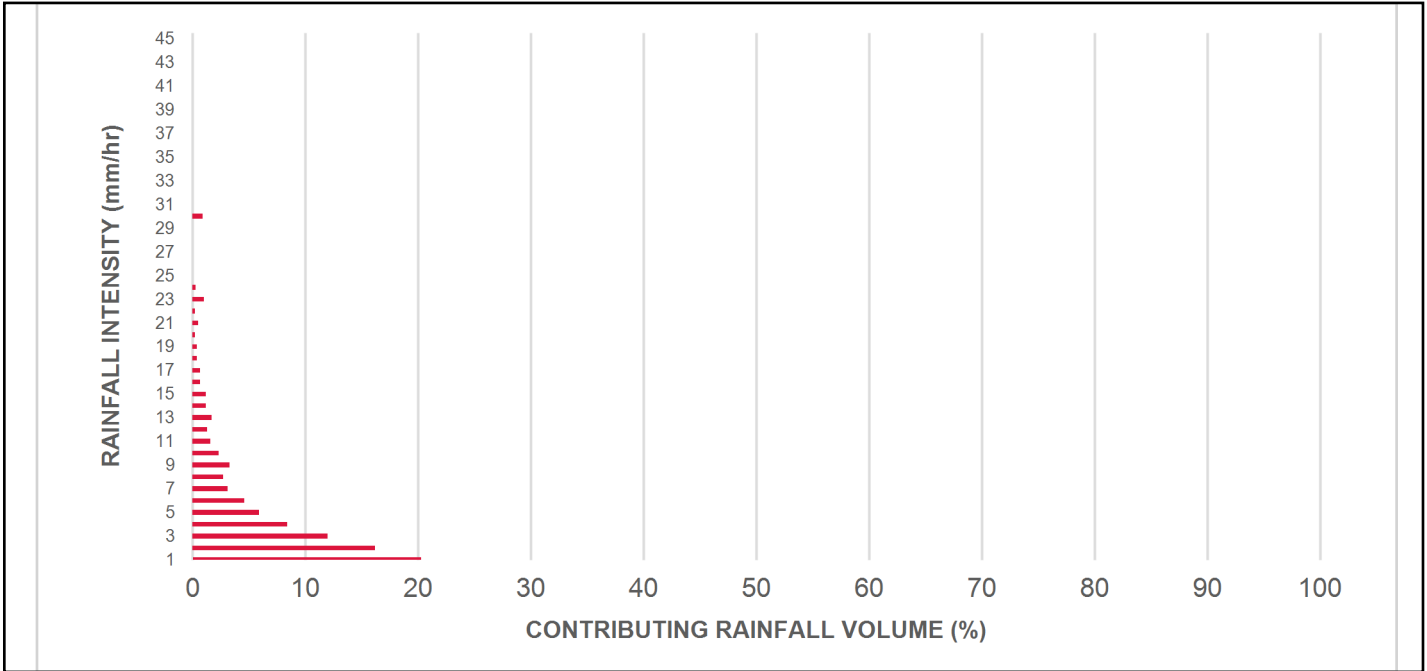

INCREMENTAL AND CUMULATIVE TSS REMOVAL FOR THE RECOMMENDED STORMCEPTOR® MODEL

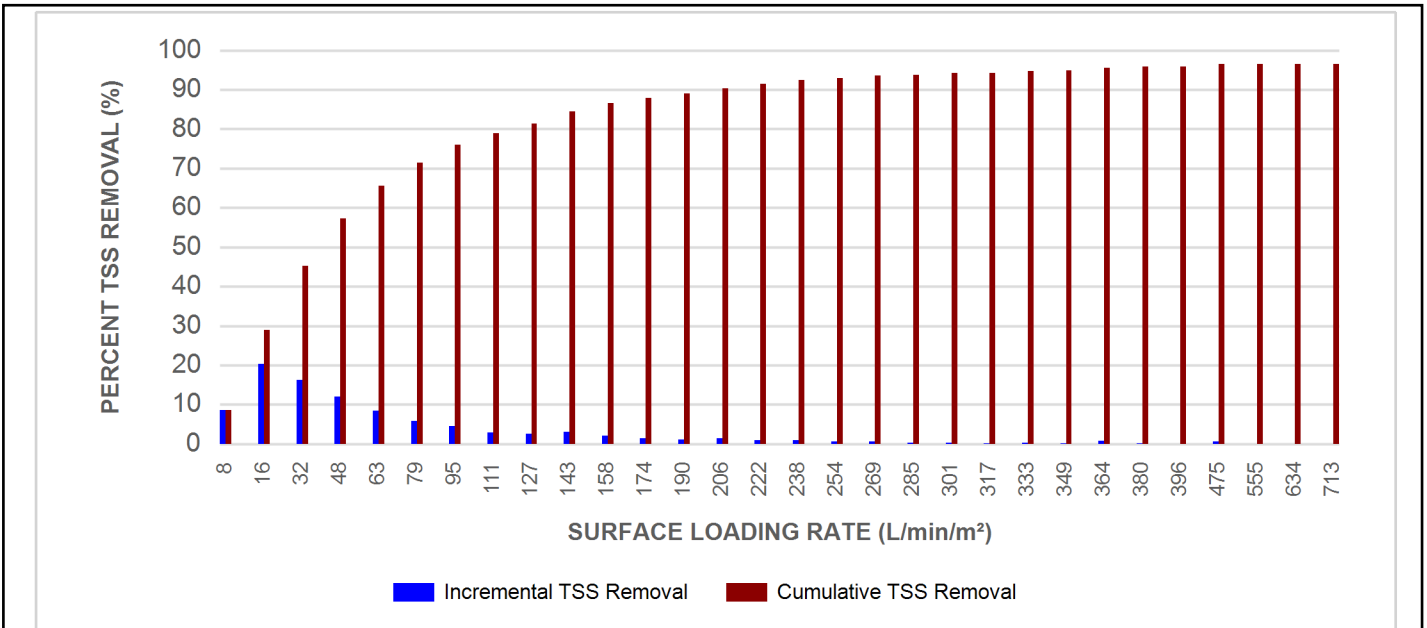

Stormceptor® EF Sizing Report

Maximum Pipe Diameter / Peak Conveyance

Stormceptor EF / EFO	Model Diameter		Min Angle Inlet / Outlet Pipes	Max Inlet Pipe Diameter		Max Outlet Pipe Diameter		Peak Conveyance Flow Rate	
	(m)	(ft)		(mm)	(in)	(mm)	(in)	(L/s)	(cfs)
EF4 / EFO4	1.2	4	90	609	24	609	24	425	15
EF6 / EFO6	1.8	6	90	914	36	914	36	990	35
EF8 / EFO8	2.4	8	90	1219	48	1219	48	1700	60
EF10 / EFO10	3.0	10	90	1828	72	1828	72	2830	100
EF12 / EFO12	3.6	12	90	1828	72	1828	72	2830	100

SCOUR PREVENTION AND ONLINE CONFIGURATION

► **Stormceptor® EF and EFO** feature an internal bypass and superior scour prevention technology that have been demonstrated in third-party testing according to the scour testing provisions of the Canadian ETV **Procedure for Laboratory Testing of Oil-Grit Separators**, and the exceptional scour test performance has been third-party verified in accordance with the ISO 14034 ETV protocol. As a result, Stormceptor EF and EFO are approved for online installation, eliminating the need for costly additional bypass structures, piping, and installation expense.

DESIGN FLEXIBILITY

► **Stormceptor® EF and EFO** offers design flexibility in one simplified platform, accepting stormwater flow from a single inlet pipe or multiple inlet pipes, and/or surface runoff through an inlet grate. The device can also serve as a junction structure, accommodate a 90-degree inlet-to-outlet bend angle, and can be modified to ensure performance in submerged conditions.

OIL CAPTURE AND RETENTION

► While Stormceptor® EF will capture and retain oil from dry weather spills and low intensity runoff, **Stormceptor® EFO** has demonstrated superior oil capture and greater than 99% oil retention in third-party testing according to the light liquid re-entrainment testing provisions of the Canadian ETV **Procedure for Laboratory Testing of Oil-Grit Separators**. Stormceptor EFO is recommended for sites where oil capture and retention is a requirement.

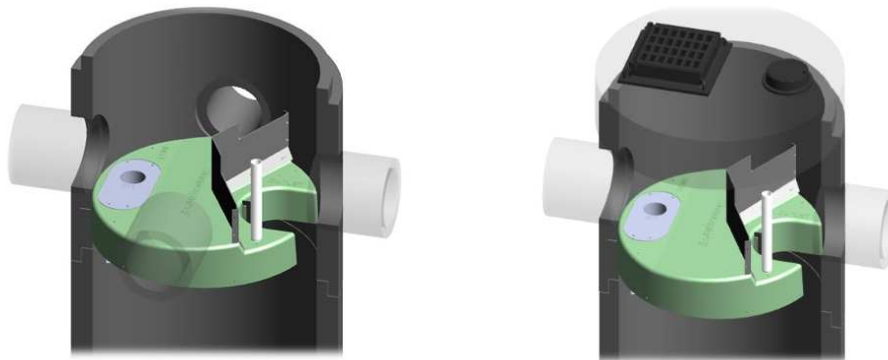

Stormceptor[®] EF Sizing Report

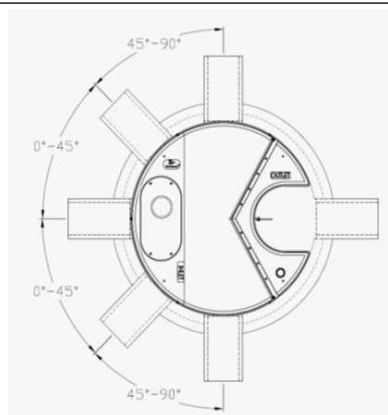

INLET-TO-OUTLET DROP

Elevation differential between inlet and outlet pipe inverts is dictated by the angle at which the inlet pipe(s) enters the unit.

0° - 45° : The inlet pipe is 1-inch (25mm) higher than the outlet pipe.

45° - 90° : The inlet pipe is 2-inches (50mm) higher than the outlet pipe.

HEAD LOSS

The head loss through Stormceptor EF is similar to that of a 60-degree bend structure. The applicable K value for calculating minor losses through the unit is 1.1.

For submerged conditions the applicable K value is 3.0.

Pollutant Capacity

Stormceptor EF / EFO	Model Diameter		Depth (Outlet Pipe Invert to Sump Floor)		Oil Volume		Recommended Sediment Maintenance Depth *		Maximum Sediment Volume *		Maximum Sediment Mass **	
	(m)	(ft)	(m)	(ft)	(L)	(Gal)	(mm)	(in)	(L)	(ft ³)	(kg)	(lb)
EF4 / EFO4	1.2	4	1.52	5.0	265	70	203	8	1190	42	1904	5250
EF6 / EFO6	1.8	6	1.93	6.3	610	160	305	12	3470	123	5552	15375
EF8 / EFO8	2.4	8	2.59	8.5	1070	280	610	24	8780	310	14048	38750
EF10 / EFO10	3.0	10	3.25	10.7	1670	440	610	24	17790	628	28464	78500
EF12 / EFO12	3.6	12	3.89	12.8	2475	655	610	24	31220	1103	49952	137875

*Increased sump depth may be added to increase sediment storage capacity

** Average density of wet packed sediment in sump = 1.6 kg/L (100 lb/ft³)

Feature	Benefit	Feature Appeals To
Patent-pending enhanced flow treatment and scour prevention technology	Superior, verified third-party performance	Regulator, Specifying & Design Engineer
Third-party verified light liquid capture and retention for EFO version	Proven performance for fuel/oil hotspot locations	Regulator, Specifying & Design Engineer, Site Owner
Functions as bend, junction or inlet structure	Design flexibility	Specifying & Design Engineer
Minimal drop between inlet and outlet	Site installation ease	Contractor
Large diameter outlet riser for inspection and maintenance	Easy maintenance access from grade	Maintenance Contractor & Site Owner

STANDARD STORMCEPTOR EF/EFO DRAWINGS

For standard details, please visit <http://www.imbriumsystems.com/stormwater-treatment-solutions/stormceptor-ef>

STANDARD STORMCEPTOR EF/EFO SPECIFICATION

For specifications, please visit <http://www.imbriumsystems.com/stormwater-treatment-solutions/stormceptor-ef>

Stormceptor[®] EF Sizing Report

STANDARD PERFORMANCE SPECIFICATION FOR “OIL GRIT SEPARATOR” (OGS) STORMWATER QUALITY TREATMENT DEVICE

PART 1 – GENERAL

1.1 WORK INCLUDED

This section specifies requirements for selecting, sizing, and designing an underground Oil Grit Separator (OGS) device for stormwater quality treatment, with third-party testing results and a Statement of Verification in accordance with ISO 14034 Environmental Management – Environmental Technology Verification (ETV).

1.2 REFERENCE STANDARDS & PROCEDURES

ISO 14034:2016 Environmental management – Environmental technology verification (ETV)

Canadian Environmental Technology Verification (ETV) Program’s **Procedure for Laboratory Testing of Oil-Grit Separators**

1.3 SUBMITTALS

1.3.1 All submittals, including sizing reports & shop drawings, shall be submitted upon request with each order to the contractor then forwarded to the Engineer of Record for review and acceptance. Shop drawings shall detail all OGS components, elevations, and sequence of construction.

1.3.2 Alternative devices shall have features identical to or greater than the specified device, including: treatment chamber diameter, treatment chamber wet volume, sediment storage volume, and oil storage volume.

1.3.3 Unless directed otherwise by the Engineer of Record, OGS stormwater quality treatment product substitutions or alternatives submitted within ten days prior to project bid shall not be accepted. All alternatives or substitutions submitted shall be signed and sealed by a local registered Professional Engineer, based on the exact same criteria detailed in Section 3, in entirety, subject to review and approval by the Engineer of Record.

PART 2 – PRODUCTS

2.1 OGS POLLUTANT STORAGE

The OGS device shall include a sump for sediment storage, and a protected volume for the capture and storage of petroleum hydrocarbons and buoyant gross pollutants. The minimum sediment & petroleum hydrocarbon storage capacity shall be as follows:

2.1.1	4 ft (1219 mm) Diameter OGS Units:	1.19 m ³ sediment / 265 L oil
	6 ft (1829 mm) Diameter OGS Units:	3.48 m ³ sediment / 609 L oil
	8 ft (2438 mm) Diameter OGS Units:	8.78 m ³ sediment / 1,071 L oil
	10 ft (3048 mm) Diameter OGS Units:	17.78 m ³ sediment / 1,673 L oil
	12 ft (3657 mm) Diameter OGS Units:	31.23 m ³ sediment / 2,476 L oil

PART 3 – PERFORMANCE & DESIGN

3.1 GENERAL

The OGS stormwater quality treatment device shall be verified in accordance with ISO 14034:2016 Environmental management – Environmental technology verification (ETV). The OGS stormwater quality treatment device shall

Stormceptor[®] EF Sizing Report

remove oil, sediment and gross pollutants from stormwater runoff during frequent wet weather events, and retain these pollutants during less frequent high flow wet weather events below the insert within the OGS for later removal during maintenance. The Manufacturer shall have at least ten (10) years of local experience, history and success in engineering design, manufacturing and production and supply of OGS stormwater quality treatment device systems, acceptable to the Engineer of Record.

3.2 SIZING METHODOLOGY

The OGS device shall be engineered, designed and sized to provide stormwater quality treatment based on treating a minimum of 90 percent of the average annual runoff volume and a minimum removal of an annual average 60% of the sediment (TSS) load based on the Particle Size Distribution (PSD) specified in the sizing report for the specified device. Sizing of the OGS shall be determined by use of a minimum ten (10) years of local historical rainfall data provided by Environment Canada. Sizing shall also be determined by use of the sediment removal performance data derived from the ISO 14034 ETV third-party verified laboratory testing data from testing conducted in accordance with the Canadian ETV protocol Procedure for Laboratory Testing of Oil-Grit Separators, as follows:

3.2.1 Sediment removal efficiency for a given surface loading rate and its associated flow rate shall be based on sediment removal efficiency demonstrated at the seven (7) tested surface loading rates specified in the protocol, ranging 40 L/min/m² to 1400 L/min/m², and as stated in the ISO 14034 ETV Verification Statement for the OGS device.

3.2.2 Sediment removal efficiency for surface loading rates between 40 L/min/m² and 1400 L/min/m² shall be based on linear interpolation of data between consecutive tested surface loading rates.

3.2.3 Sediment removal efficiency for surface loading rates less than the lowest tested surface loading rate of 40 L/min/m² shall be assumed to be identical to the sediment removal efficiency at 40 L/min/m². No extrapolation shall be allowed that results in a sediment removal efficiency that is greater than that demonstrated at 40 L/min/m².

3.2.4 Sediment removal efficiency for surface loading rates greater than the highest tested surface loading rate of 1400 L/min/m² shall assume zero sediment removal for the portion of flow that exceeds 1400 L/min/m², and shall be calculated using a simple proportioning formula, with 1400 L/min/m² in the numerator and the higher surface loading rate in the denominator, and multiplying the resulting fraction times the sediment removal efficiency at 1400 L/min/m².

The OGS device shall also have sufficient annual sediment storage capacity as specified and calculated in Section 2.1.

3.3 CANADIAN ETV or ISO 14034 ETV VERIFICATION OF SCOUR TESTING

The OGS device shall have Canadian ETV or ISO 14034 ETV Verification of third-party scour testing conducted in accordance with the Canadian ETV Program's **Procedure for Laboratory Testing of Oil-Grit Separators**.

3.3.1 To be acceptable for on-line installation, the OGS device must demonstrate an average scour test effluent concentration less than 10 mg/L at each surface loading rate tested, up to and including 2600 L/min/m².

3.4 LIGHT LIQUID RE-ENTRAINMENT SIMULATION TESTING

The OGS device shall have Canadian ETV or ISO 14034 ETV Verification of completed third-party Light Liquid Re-entrainment Simulation Testing in accordance with the Canadian ETV **Program's Procedure for Laboratory Testing of Oil-Grit Separators**, with results reported within the Canadian ETV or ISO 14034 ETV verification. This re-entrainment testing is conducted with the device pre-loaded with low density polyethylene (LDPE) plastic beads as a surrogate for light liquids such as oil and fuel. Testing is conducted on the same OGS unit tested for sediment removal to

Stormceptor[®] EF Sizing Report

assess whether light liquids captured after a spill are effectively retained at high flow rates.

3.4.1 For an OGS device to be an acceptable stormwater treatment device on a site where vehicular traffic occurs and the potential for an oil or fuel spill exists, the OGS device must have reported verified performance results of greater than 99% cumulative retention of LDPE plastic beads for the five specified surface loading rates (ranging 200 L/min/m² to 2600 L/min/m²) in accordance with the Light Liquid Re-entrainment Simulation Testing within the Canadian ETV Program's **Procedure for Laboratory Testing of Oil-Grit Separators**. However, an OGS device shall not be allowed if the Light Liquid Re-entrainment Simulation Testing was performed with screening components within the OGS device that are effective at retaining the LDPE plastic beads, but would not be expected to retain light liquids such as oil and fuel.

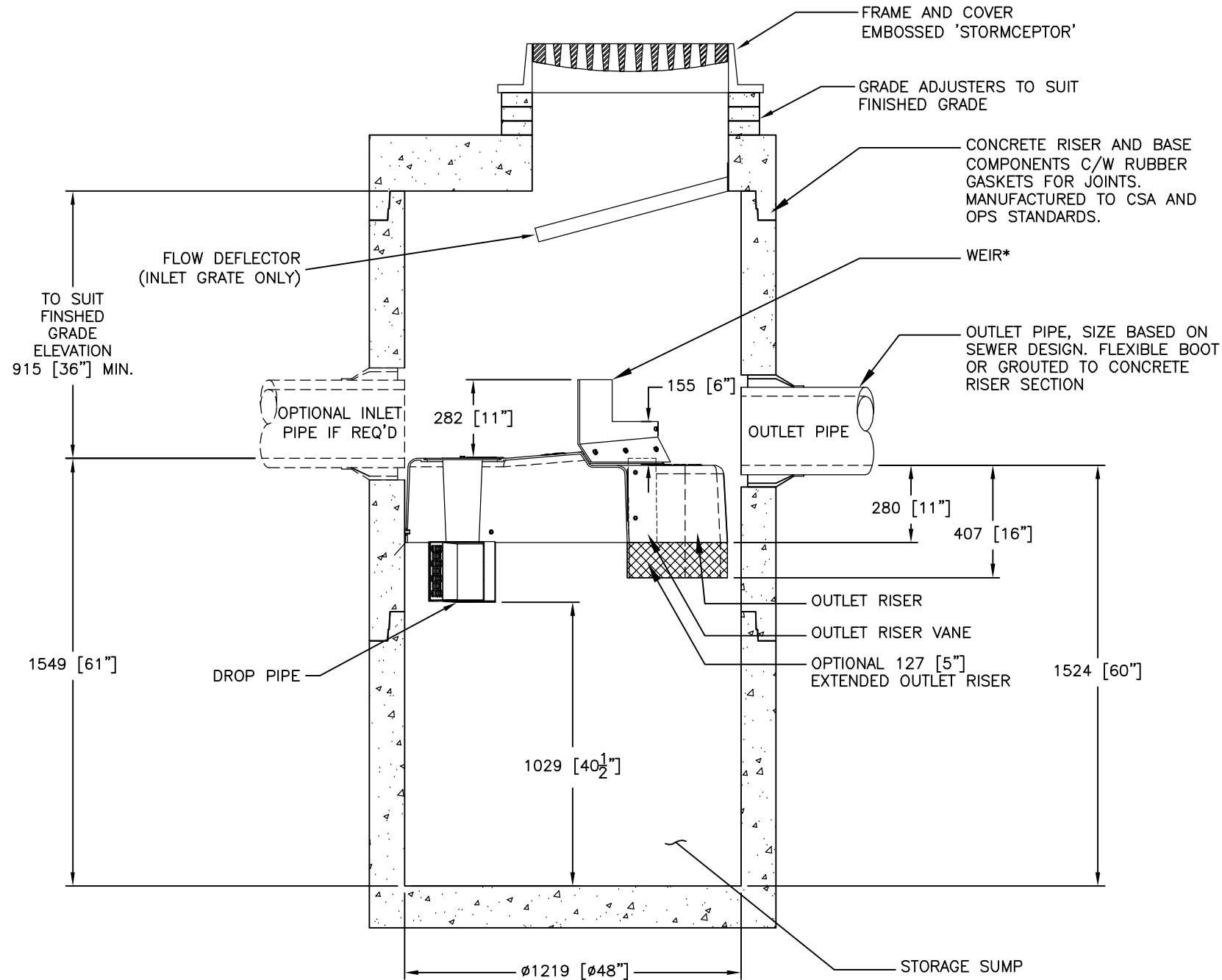

SECTION VIEW

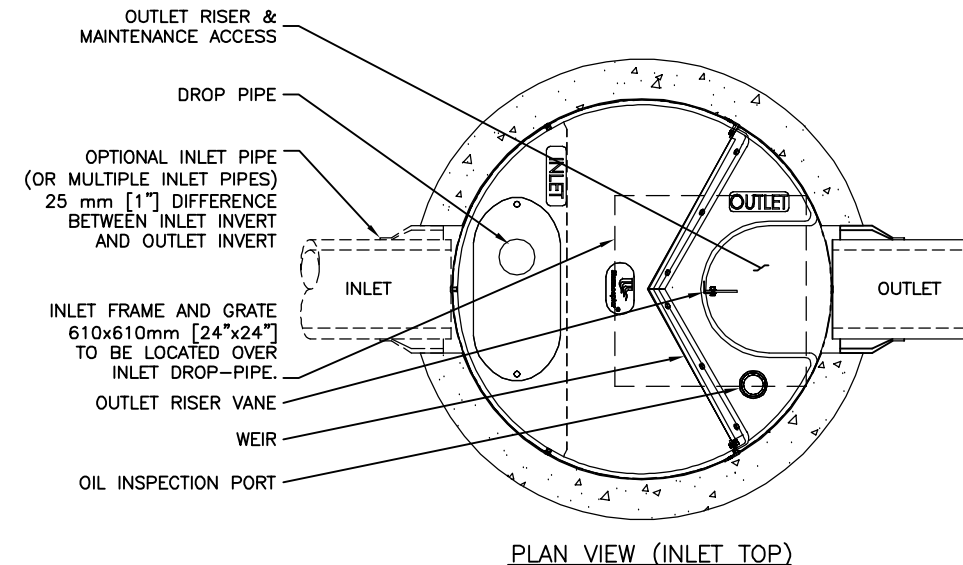
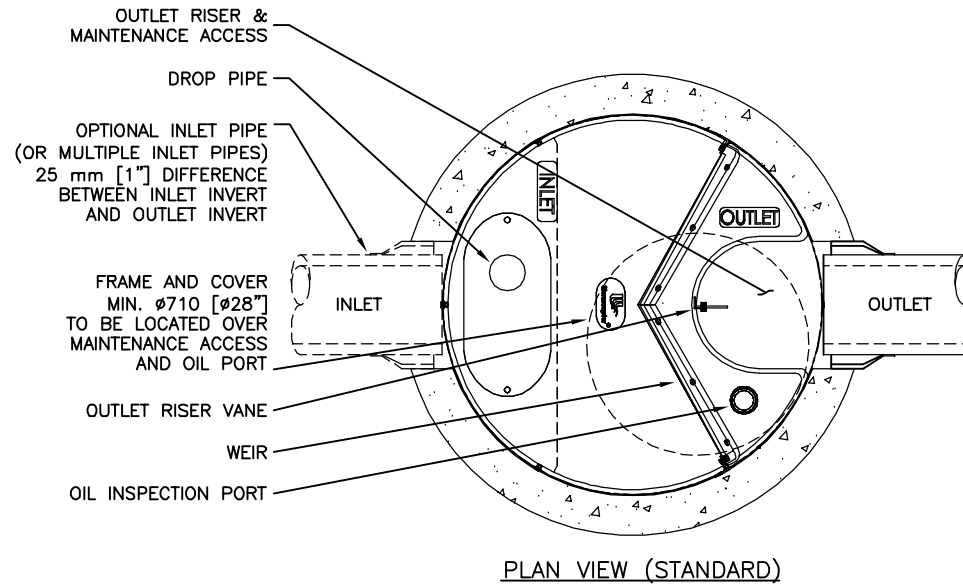

FOR SITE SPECIFIC DRAWINGS PLEASE CONTACT YOUR LOCAL STORMCEPTOR REPRESENTATIVE. SITE SPECIFIC DRAWINGS ARE BASED ON THE BEST AVAILABLE INFORMATION AT THE TIME. SOME FIELD REVISIONS TO THE SYSTEM LOCATION OR CONNECTION PIPING MAY BE NECESSARY BASED ON AVAILABLE SPACE OR SITE CONFIGURATION REVISIONS. ELEVATIONS SHOULD BE MAINTAINED EXCEPT WHERE NOTED ON BYPASS STRUCTURE (IF REQUIRED).

GENERAL NOTES:

- * MAXIMUM SURFACE LOADING RATE (SLR) INTO LOWER CHAMBER THROUGH DROP PIPE IS 1135 L/min/m² (27.9 gpm/ft²) FOR STORMCEPTOR EF4 AND 535 L/min/m² (13.1 gpm/ft²) FOR STORMCEPTOR EFO4 (OIL CAPTURE CONFIGURATION). WEIR HEIGHT IS 150 mm (6 INCH) FOR EF04.
- 1. ALL DIMENSIONS INDICATED ARE IN MILLIMETERS (INCHES) UNLESS OTHERWISE SPECIFIED.
- 2. STORMCEPTOR STRUCTURE INLET AND OUTLET PIPE SIZE AND ORIENTATION SHOWN FOR INFORMATIONAL PURPOSES ONLY.
- 3. UNLESS OTHERWISE NOTED, BYPASS INFRASTRUCTURE, SUCH AS ALL UPSTREAM DIVERSION STRUCTURES, CONNECTING STRUCTURES, OR PIPE CONDUITS CONNECTING TO COMPLETE THE STORMCEPTOR SYSTEM SHALL BE PROVIDED AND ADDRESSED SEPARATELY.
- 4. DRAWING FOR INFORMATIONAL PURPOSES ONLY. REFER TO ENGINEER'S SITE/UTILITY PLAN FOR STRUCTURE ORIENTATION.
- 5. NO PRODUCT SUBSTITUTIONS SHALL BE ACCEPTED UNLESS SUBMITTED 10 DAYS PRIOR TO PROJECT BID DATE, OR AS DIRECTED BY THE ENGINEER OF RECORD.

INSTALLATION NOTES

- A. ANY SUB-BASE, BACKFILL DEPTH, AND/OR ANTI-FLOTATION PROVISIONS ARE SITE-SPECIFIC DESIGN CONSIDERATIONS AND SHALL BE SPECIFIED BY ENGINEER OF RECORD.
- B. CONTRACTOR TO PROVIDE EQUIPMENT WITH SUFFICIENT LIFTING AND REACH CAPACITY TO LIFT AND SET THE STRUCTURE (LIFTING CLUTCHES PROVIDED)
- C. CONTRACTOR WILL INSTALL AND LEVEL THE STRUCTURE, SEALING THE JOINTS, LINE ENTRY AND EXIT POINTS (NON-SHRINK GROUT WITH APPROVED WATERSTOP OR FLEXIBLE BOOT)
- D. CONTRACTOR TO TAKE APPROPRIATE MEASURES TO PROTECT THE DEVICE FROM CONSTRUCTION-RELATED EROSION RUNOFF.
- E. DEVICE ACTIVATION, BY CONTRACTOR, SHALL OCCUR ONLY AFTER SITE HAS BEEN STABILIZED AND THE STORMCEPTOR UNIT IS CLEAN AND FREE OF DEBRIS.

**STANDARD DETAIL
NOT FOR CONSTRUCTION**

SITE SPECIFIC DATA REQUIREMENTS

STORMCEPTOR MODEL	EFO4
STRUCTURE ID	*
HYDROCARBON STORAGE REQ'D (L)	*
WATER QUALITY FLOW RATE (L/s)	*
PEAK FLOW RATE (L/s)	*
RETURN PERIOD OF PEAK FLOW (yrs)	*
DRAINAGE AREA (HA)	*
DRAINAGE AREA IMPERVIOUSNESS (%)	*
PIPE DATA:	I.E. MAT'L DIA SLOPE % HGL
INLET #1	* * * * *
INLET #2	* * * * *
OUTLET	* * * * *

* PER ENGINEER OF RECORD

This design and information is provided as a service to the product owner. Imbrium Systems ("Imbrium") and contractor by Imbrium Systems ("Imbrium"). Neither the drawing, nor any part thereof, may be reproduced, stored in a retrieval system, or used in any form without the prior written consent of Imbrium. Failure to comply with these terms may result in Imbrium expressly disclaiming any liability or responsibility for such use. If discrepancies between the supplied information upon which the drawing is based and actual field conditions are discovered, Imbrium does not warrant, accept any liability for design based on missing, incomplete or inaccurate information supplied by others.

#####	#####	#####	#####	#####	#####
#####	#####	#####	#####	#####	#####
#####	#####	#####	#####	#####	#####
#####	#####	#####	#####	#####	#####
#####	#####	#####	#####	#####	#####
#####	#####	#####	#####	#####	#####
#####	#####	#####	#####	#####	#####
#####	#####	#####	#####	#####	#####
#####	#####	#####	#####	#####	#####
#####	#####	#####	#####	#####	#####
#####	#####	#####	#####	#####	#####
#####	#####	#####	#####	#####	#####
#####	#####	#####	#####	#####	#####
#####	#####	#####	#####	#####	#####
#####	#####	#####	#####	#####	#####
#####	#####	#####	#####	#####	#####
#####	#####	#####	#####	#####	#####
#####	#####	#####	#####	#####	#####
#####	#####	#####	#####	#####	#####
#####	#####	#####	#####	#####	#####
#####	#####	#####	#####	#####	#####
#####	#####	#####	#####	#####	#####
#####	#####	#####	#####	#####	#####
#####	#####	#####	#####	#####	#####
#####	#####	#####	#####	#####	#####
#####	#####	#####	#####	#####	#####
#####	#####	#####	#####	#####	#####
#####	#####	#####	#####	#####	#####
#####	#####	#####	#####	#####	#####
#####	#####	#####	#####	#####	#####

SCALE = NTS

407 FAIRVIEW DRIVE, WHITBY, ON L1N 3J9
 TEL: 905-355-4801 CA: 416-960-9800 INTL: +1-416-960-9800
 THE ENGINEER/OWNER IS RESPONSIBLE FOR OBTAINING ALL NECESSARY PERMITS AND APPROVALS FROM THE LOCAL AUTHORITIES. IMBRIMUM SYSTEMS, L.P. (A LIMITED LIABILITY COMPANY) AND IMBRIMUM SYSTEMS INC. (A CORPORATION) ARE REGISTERED PROFESSIONAL ENGINEERS IN THE PROVINCE OF ONTARIO, CANADA. IMBRIMUM SYSTEMS, L.P. IS REGISTERED AS A PROFESSIONAL ENGINEER IN THE STATE OF CALIFORNIA, U.S.A. IMBRIMUM SYSTEMS, L.P. IS REGISTERED AS A PROFESSIONAL ENGINEER IN THE STATE OF TEXAS, U.S.A. IMBRIMUM SYSTEMS, L.P. IS REGISTERED AS A PROFESSIONAL ENGINEER IN THE STATE OF FLORIDA, U.S.A. IMBRIMUM SYSTEMS, L.P. IS REGISTERED AS A PROFESSIONAL ENGINEER IN THE STATE OF ALABAMA, U.S.A. IMBRIMUM SYSTEMS, L.P. IS REGISTERED AS A PROFESSIONAL ENGINEER IN THE STATE OF MISSISSIPPI, U.S.A. IMBRIMUM SYSTEMS, L.P. IS REGISTERED AS A PROFESSIONAL ENGINEER IN THE STATE OF MISSOURI, U.S.A. IMBRIMUM SYSTEMS, L.P. IS REGISTERED AS A PROFESSIONAL ENGINEER IN THE STATE OF ILLINOIS, U.S.A. IMBRIMUM SYSTEMS, L.P. IS REGISTERED AS A PROFESSIONAL ENGINEER IN THE STATE OF INDIANA, U.S.A. IMBRIMUM SYSTEMS, L.P. IS REGISTERED AS A PROFESSIONAL ENGINEER IN THE STATE OF OHIO, U.S.A. IMBRIMUM SYSTEMS, L.P. IS REGISTERED AS A PROFESSIONAL ENGINEER IN THE STATE OF PENNSYLVANIA, U.S.A. IMBRIMUM SYSTEMS, L.P. IS REGISTERED AS A PROFESSIONAL ENGINEER IN THE STATE OF WISCONSIN, U.S.A. IMBRIMUM SYSTEMS, L.P. IS REGISTERED AS A PROFESSIONAL ENGINEER IN THE STATE OF IOWA, U.S.A. IMBRIMUM SYSTEMS, L.P. IS REGISTERED AS A PROFESSIONAL ENGINEER IN THE STATE OF NEBRASKA, U.S.A. IMBRIMUM SYSTEMS, L.P. IS REGISTERED AS A PROFESSIONAL ENGINEER IN THE STATE OF KANSAS, U.S.A. IMBRIMUM SYSTEMS, L.P. IS REGISTERED AS A PROFESSIONAL ENGINEER IN THE STATE OF OKLAHOMA, U.S.A. IMBRIMUM SYSTEMS, L.P. IS REGISTERED AS A PROFESSIONAL ENGINEER IN THE STATE OF ARIZONA, U.S.A. IMBRIMUM SYSTEMS, L.P. IS REGISTERED AS A PROFESSIONAL ENGINEER IN THE STATE OF NEVADA, U.S.A. IMBRIMUM SYSTEMS, L.P. IS REGISTERED AS A PROFESSIONAL ENGINEER IN THE STATE OF UTAH, U.S.A. IMBRIMUM SYSTEMS, L.P. IS REGISTERED AS A PROFESSIONAL ENGINEER IN THE STATE OF MONTANA, U.S.A. IMBRIMUM SYSTEMS, L.P. IS REGISTERED AS A PROFESSIONAL ENGINEER IN THE STATE OF WYOMING, U.S.A. IMBRIMUM SYSTEMS, L.P. IS REGISTERED AS A PROFESSIONAL ENGINEER IN THE STATE OF COLORADO, U.S.A. IMBRIMUM SYSTEMS, L.P. IS REGISTERED AS A PROFESSIONAL ENGINEER IN THE STATE OF NEW MEXICO, U.S.A. IMBRIMUM SYSTEMS, L.P. IS REGISTERED AS A PROFESSIONAL ENGINEER IN THE STATE OF NEW JERSEY, U.S.A. IMBRIMUM SYSTEMS, L.P. IS REGISTERED AS A PROFESSIONAL ENGINEER IN THE STATE OF DELAWARE, U.S.A. IMBRIMUM SYSTEMS, L.P. IS REGISTERED AS A PROFESSIONAL ENGINEER IN THE STATE OF MARYLAND, U.S.A. IMBRIMUM SYSTEMS, L.P. IS REGISTERED AS A PROFESSIONAL ENGINEER IN THE STATE OF VIRGINIA, U.S.A. IMBRIMUM SYSTEMS, L.P. IS REGISTERED AS A PROFESSIONAL ENGINEER IN THE STATE OF NORTH CAROLINA, U.S.A. IMBRIMUM SYSTEMS, L.P. IS REGISTERED AS A PROFESSIONAL ENGINEER IN THE STATE OF SOUTH CAROLINA, U.S.A. IMBRIMUM SYSTEMS, L.P. IS REGISTERED AS A PROFESSIONAL ENGINEER IN THE STATE OF GEORGIA, U.S.A. IMBRIMUM SYSTEMS, L.P. IS REGISTERED AS A PROFESSIONAL ENGINEER IN THE STATE OF ALABAMA, U.S.A. IMBRIMUM SYSTEMS, L.P. IS REGISTERED AS A PROFESSIONAL ENGINEER IN THE STATE OF MISSISSIPPI, U.S.A. IMBRIMUM SYSTEMS, L.P. IS REGISTERED AS A PROFESSIONAL ENGINEER IN THE STATE OF LOUISIANA, U.S.A. IMBRIMUM SYSTEMS, L.P. IS REGISTERED AS A PROFESSIONAL ENGINEER IN THE STATE OF MISSOURI, U.S.A. IMBRIMUM SYSTEMS, L.P. IS REGISTERED AS A PROFESSIONAL ENGINEER IN THE STATE OF ILLINOIS, U.S.A. IMBRIMUM SYSTEMS, L.P. IS REGISTERED AS A PROFESSIONAL ENGINEER IN THE STATE OF INDIANA, U.S.A. IMBRIMUM SYSTEMS, L.P. IS REGISTERED AS A PROFESSIONAL ENGINEER IN THE STATE OF OHIO, U.S.A. IMBRIMUM SYSTEMS, L.P. IS REGISTERED AS A PROFESSIONAL ENGINEER IN THE STATE OF PENNSYLVANIA, U.S.A. IMBRIMUM SYSTEMS, L.P. IS REGISTERED AS A PROFESSIONAL ENGINEER IN THE STATE OF WISCONSIN, U.S.A. IMBRIMUM SYSTEMS, L.P. IS REGISTERED AS A PROFESSIONAL ENGINEER IN THE STATE OF IOWA, U.S.A. IMBRIMUM SYSTEMS, L.P. IS REGISTERED AS A PROFESSIONAL ENGINEER IN THE STATE OF NEBRASKA, U.S.A. IMBRIMUM SYSTEMS, L.P. IS REGISTERED AS A PROFESSIONAL ENGINEER IN THE STATE OF KANSAS, U.S.A. IMBRIMUM SYSTEMS, L.P. IS REGISTERED AS A PROFESSIONAL ENGINEER IN THE STATE OF OKLAHOMA, U.S.A. IMBRIMUM SYSTEMS, L.P. IS REGISTERED AS A PROFESSIONAL ENGINEER IN THE STATE OF ARIZONA, U.S.A. IMBRIMUM SYSTEMS, L.P. IS REGISTERED AS A PROFESSIONAL ENGINEER IN THE STATE OF NEVADA, U.S.A. IMBRIMUM SYSTEMS, L.P. IS REGISTERED AS A PROFESSIONAL ENGINEER IN THE STATE OF UTAH, U.S.A. IMBRIMUM SYSTEMS, L.P. IS REGISTERED AS A PROFESSIONAL ENGINEER IN THE STATE OF MONTANA, U.S.A. IMBRIMUM SYSTEMS, L.P. IS REGISTERED AS A PROFESSIONAL ENGINEER IN THE STATE OF WYOMING, U.S.A. IMBRIMUM SYSTEMS, L.P. IS REGISTERED AS A PROFESSIONAL ENGINEER IN THE STATE OF COLORADO, U.S.A. IMBRIMUM SYSTEMS, L.P. IS REGISTERED AS A PROFESSIONAL ENGINEER IN THE STATE OF NEW MEXICO, U.S.A. IMBRIMUM SYSTEMS, L.P. IS REGISTERED AS A PROFESSIONAL ENGINEER IN THE STATE OF NEW JERSEY, U.S.A. IMBRIMUM SYSTEMS, L.P. IS REGISTERED AS A PROFESSIONAL ENGINEER IN THE STATE OF DELAWARE, U.S.A. IMBRIMUM SYSTEMS, L.P. IS REGISTERED AS A PROFESSIONAL ENGINEER IN THE STATE OF MARYLAND, U.S.A. IMBRIMUM SYSTEMS, L.P. IS REGISTERED AS A PROFESSIONAL ENGINEER IN THE STATE OF VIRGINIA, U.S.A. IMBRIMUM SYSTEMS, L.P. IS REGISTERED AS A PROFESSIONAL ENGINEER IN THE STATE OF NORTH CAROLINA, U.S.A. IMBRIMUM SYSTEMS, L.P. IS REGISTERED AS A PROFESSIONAL ENGINEER IN THE STATE OF SOUTH CAROLINA, U.S.A. IMBRIMUM SYSTEMS, L.P. IS REGISTERED AS A PROFESSIONAL ENGINEER IN THE STATE OF GEORGIA, U.S.A.

DATE: 10/13/2017
 DESIGNED: JSK
 CHECKED: BSF
 PROJECT No.: EFO4
 SHEET: 1 OF 1
 DRAWN: JSK
 APPROVED: SP
 SEQUENCE No.: *
 REVISION DESCRIPTION

Stormceptor® EF



Stormceptor® EF Overview

About Imbrium® Systems

Imbrium® Systems is dedicated to protecting Canada's waterways. Based on our knowledge and experience in the Canadian stormwater industry, we have the ability to provide the most effective stormwater treatment technologies that capture and retain harmful pollutants from urban runoff before it enters our streams, rivers, lakes, and oceans.

Imbrium's engineered treatment solutions have been third-party tested and verified in accordance with the ISO 14034 Environmental Technology Verification (ETV) protocol to ensure performance in real-world conditions as designed. Our team of highly skilled engineers and partners provide the highest level of service from design to installation and long-term maintenance.

By working with Imbrium and our partners, you can expect superior treatment technology, unparalleled customer service, compliance with local stormwater regulations, and cleaner water. To find your local representative, please visit www.imbriumsystems.com/localrep.



Learn About the Stormceptor® EF

Go online and watch our animation to learn how the Stormceptor EF works. The animation highlights important features of the Stormceptor EF including:

- Functionality
- Applications
- Inspection and Maintenance

To view the Stormceptor EF animation, visit www.imbriumsystems.com/stormceptoref

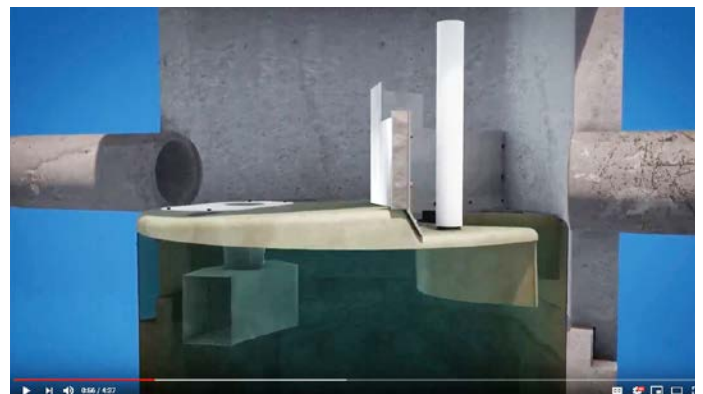

Stormceptor® EF

A CONTINUATION AND EVOLUTION OF THE MOST GLOBALLY RECOGNIZED OIL GRIT SEPARATOR (OGS) STORMWATER TREATMENT TECHNOLOGY

Stormceptor EF effectively targets sediment (TSS), free oils, gross pollutants and other pollutants that attach to particles, such as nutrients and metals. Stormceptor EF's independently tested and verified, patent-pending treatment and scour prevention platform ensures pollutants are captured and contained during all rainfall events.

Stormceptor EF also offers design flexibility in one platform, accepting flow from a single inlet pipe, multiple inlet pipes, and from the surface through an inlet grate. Stormceptor EF can also accommodate a 90-degree inlet to outlet bend angle, and tailwater conditions.

Ideal Uses

- Sediment (TSS) removal
- Hydrocarbon control and hotspots (Stormceptor EF)
- Debris and small floatables capture
- Pretreatment for filtration, detention/retention systems, ponds, wetlands, and bioretention
- Retrofit and redevelopment projects

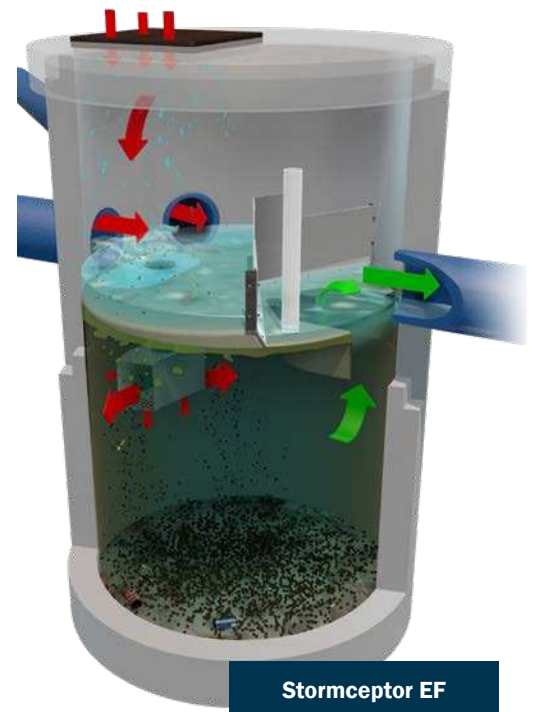

Stormceptor EF and Stormceptor EFO have been verified in accordance with ISO 14034 Environment Management - Environmental Technology Verification (ETV) protocol.

How the Stormceptor® EF Works

- Flow enters the Stormceptor through one or more inlet pipes or an inlet grate.
- A specially designed insert reduces influent velocity by creating a pond upstream of the weir, allowing sediments to begin settling.
- Swirling flow sweeps water and pollutants across the sloped insert surface to the drop pipe, where a strong vortex draws water, sediment, oil, and debris down the drop pipe cone and into the lower chamber.
- Flow exits the drop pipe through two large rectangular openings, while also diffusing through perforations in multiple directions. This reduces stream velocities and increases pollutant removal efficiency while preventing resuspension and washout of previously captured pollutants.
- Floatables, such as oil and gross pollutants, rise up and are trapped beneath the insert.
- Sediment settles to the sump.
- Treated stormwater discharges to the top side of the insert downstream of the weir, where it exits through the outlet pipe.
- During intense storm events excess influent passes over the weir and exits through the outlet pipe. The pond continues to separate sediment from all incoming flows, while full treatment in the lower chamber continues at the maximum flow rate, without scour of previously captured pollutants.

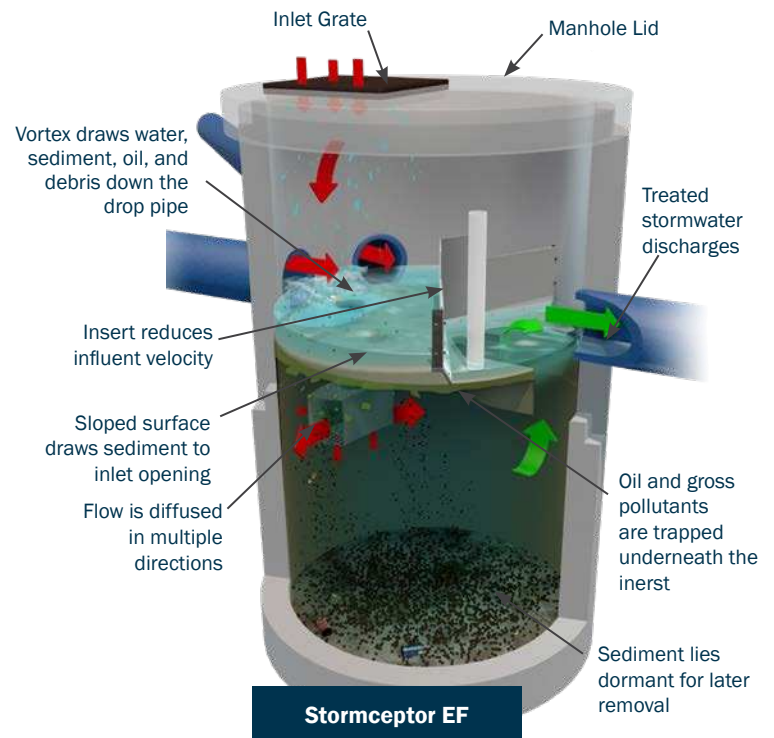

* Fiberglass system is an option

Stormceptor® EF Features & Benefits



EASY TO INSTALL

Small footprint saves time and money with limited disruption to your site.

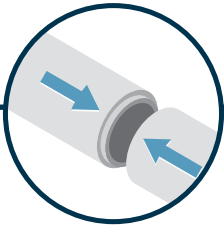

SEAMLESS

Minimal drop between inlet and outlet pipes makes Stormceptor ideal for retrofits and new development projects.

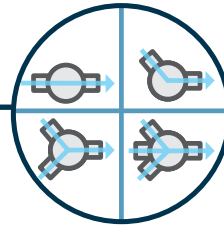

FLEXIBLE

Multiple inlets can connect to a single unit. Can be used as a bend structure.

FEATURES	BENEFITS
Patent-pending enhanced flow treatment and scour prevention technology	Superior, third-party verified performance
Third-party verified light liquid capture and retention (EFO version)	Proven performance for fuel/oil hotspot locations
Functions as bend, junction or inlet structure	Cost savings and design flexibility
Minimal drop between inlet and outlet	Site installation ease
Large diameter outlet riser for inspection and maintenance	Easy maintenance access from grade



Stormceptor® EF Standard Configurations

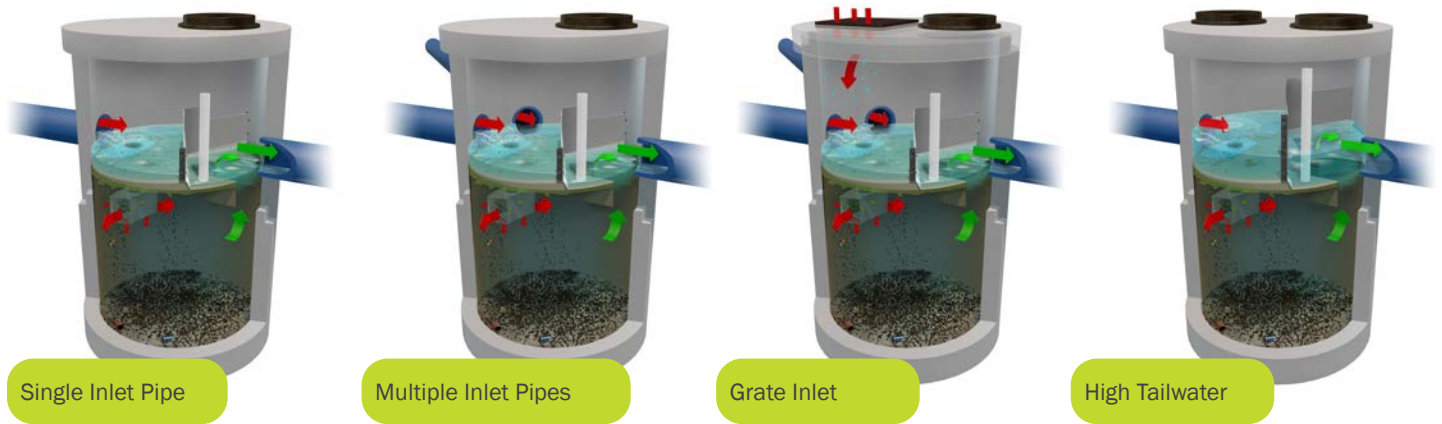

OPTIONS & ACCESSORIES

The following options and accessories are available for specific functions and site conditions:

- **Tailwater/Submerged Site** – For sites with standing water during dry weather periods, weir modifications can be implemented to ensure optimal performance.
- **Additional Sediment Storage Volume** – For sites with high pollutant loads or remote sites, additional sediment storage volume can easily be added.
- **Oil Alarm** – To mitigate spill liability, a monitoring system can be employed to trigger a visual and audible alarm when an oil or fuel spill occurs.
- **Additional Oil Capture** – A draw-off tank can be incorporated to increase spill storage capacity.
- **High Load** – Standard design loading is CHBDC or AASHTO H-20. Specialized loading can be designed to withstand very high loadings typical of airports and port facilities.
- **Lightweight** – Sites that required lightweight or above ground units are available as complete fiberglass systems.



Optional Oil Alarm

For any of these options or accessories, please contact your Stormceptor representative for design assistance.

Stormceptor® EFO

Accidents and spills happen, whether it is a fueling station, port, industrial site, or general hot spot with daily vehicle traffic. Protect the environment and your site from potentially costly clean-up, remediation, litigation and fines with the Stormceptor EFO configuration.

The Stormceptor EFO has been third-party tested to ensure oil capture, and retention during high flow events. The hydraulics of the Stormceptor EFO have been optimized to enhance oil and hydrocarbon capture.

STORMCEPTOR EFO – HYDROCARBON SPILL PROTECTION

- Stormceptor EFO configuration has been third-party performance tested for safe oil capture and retention.
- Patent-pending technology ensures captured oil and sediment are retained even during the largest rain events, for secure storage, environmental protection and easy removal.
- Stormceptor EFO provides double wall containment for captured hydrocarbons.
- Stormceptor EFO is ideal for gas stations, fuel depots, ports, garages, loading docks, industrial sites, fast food locations, high-collision intersections and other hotspots with spill-prone areas.
- Stormceptor EFO can accommodate an optional oil alarm and additional storage to increase spill storage capacity.

Stormceptor® Inspection & Maintenance

Conducted at grade, the Stormceptor EF design makes inspection and maintenance an easy and inexpensive process. Once maintained, the Stormceptor EF is functionally restored as designed, with full pollutant capture capacity.

MAINTENANCE RECOMMENDATIONS:

- Inspect every six months for the first year to determine the pollutant accumulation rate.
- In subsequent years, inspections can be based on observations or local requirements.
- Inspect the unit immediately after an oil, fuel or chemical spill. A licensed waste management company should remove oil and sediment, and dispose responsibly.

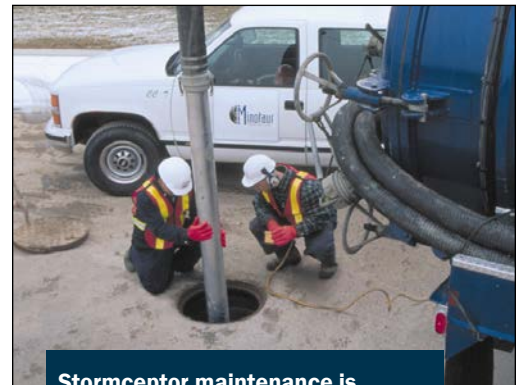

Stormceptor maintenance is performed at grade with a standard vacuum truck

ADDITIONAL SOLUTIONS



FILTERRA® BIORETENTION

The Filterra® Bioretention System is an engineered biofiltration device with components that make it similar to bioretention in pollutant removal and application, but has been optimized for high volume/flow treatment in a compact system.

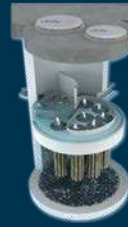

JELLYFISH® FILTER

The Jellyfish® Filter is a stormwater treatment technology featuring pretreatment and membrane filtration in a compact stand-alone treatment system that removes a high level and a wide variety of stormwater pollutants.

LEARN MORE

- Access project profiles, photos, videos, and more online at www.imbriumsystems.com/stormceptoref.

REQUEST DESIGN ASSISTANCE

- Call us at (888) 279-8826 or 301-279-8827 to talk to one of our engineers for technical support or design assistance.

START A PROJECT

- Submit your system requirements on our product Design Worksheet at www.imbriumsystems.com/pdw.

FIND A LOCAL REPRESENTATIVE

- Visit www.imbrumsystems.com/localrep for contact information for your local Imbrium representative.



© 2021 Imbrium Systems Inc.

+1 416-960-9900

www.imbriumsystems.com

All Rights Reserved.

Imbrium® Systems is an engineered stormwater treatment company that designs and manufactures stormwater treatment solutions that protect water resources from harmful pollutants. By developing technologies to address the long-term impact of urban runoff, Imbrium ensures our clients' projects are compliant with government water quality regulations. For information, visit www.imbriumsystems.com or call +1 416-960-9900.

Get Social With Us!



IB-Stormceptor EF Bro 4/21 PDF



MADE IN CANADA
By Canadians, for Canadians.

NOTHING IN THIS CATALOG SHOULD BE CONSTRUED AS AN EXPRESSED WARRANTY OR AN IMPLIED WARRANTY OF MERCHANTABILITY OR FITNESS FOR ANY PARTICULAR PURPOSE. SEE THE IMBRIUM STANDARD CONDITIONS OF SALE (VIEWABLE AT WWW.IMBRIUMSYSTEMS.COM/TERMS-OF-USE) FOR MORE INFORMATION.

VERIFICATION STATEMENT

GLOBE Performance Solutions

Verifies the performance of

Stormceptor® EF4 and EFO4 Oil-Grit Separators

Developed by Imbrium Systems, Inc.,
Whitby, Ontario, Canada

In accordance with

ISO 14034:2016

**Environmental management —
Environmental technology verification (ETV)**



John D. Wiebe, PhD
Executive Chairman
GLOBE Performance Solutions



November 10, 2017
Vancouver, BC, Canada

Verification Body
GLOBE Performance Solutions
404 – 999 Canada Place | Vancouver, B.C | Canada | V6C 3E2

Technology description and application

The Stormceptor® EF4 and EFO4 are treatment devices designed to remove oil, sediment, trash, debris, and pollutants attached to particulates from Stormwater and snowmelt runoff. The device takes the place of a conventional manhole within a storm drain system and offers design flexibility that works with various site constraints. The EFO4 is designed with a shorter bypass weir height, which accepts lower surface loading rate into the sump, thereby reducing re-entrainment of captured free floating light liquids.

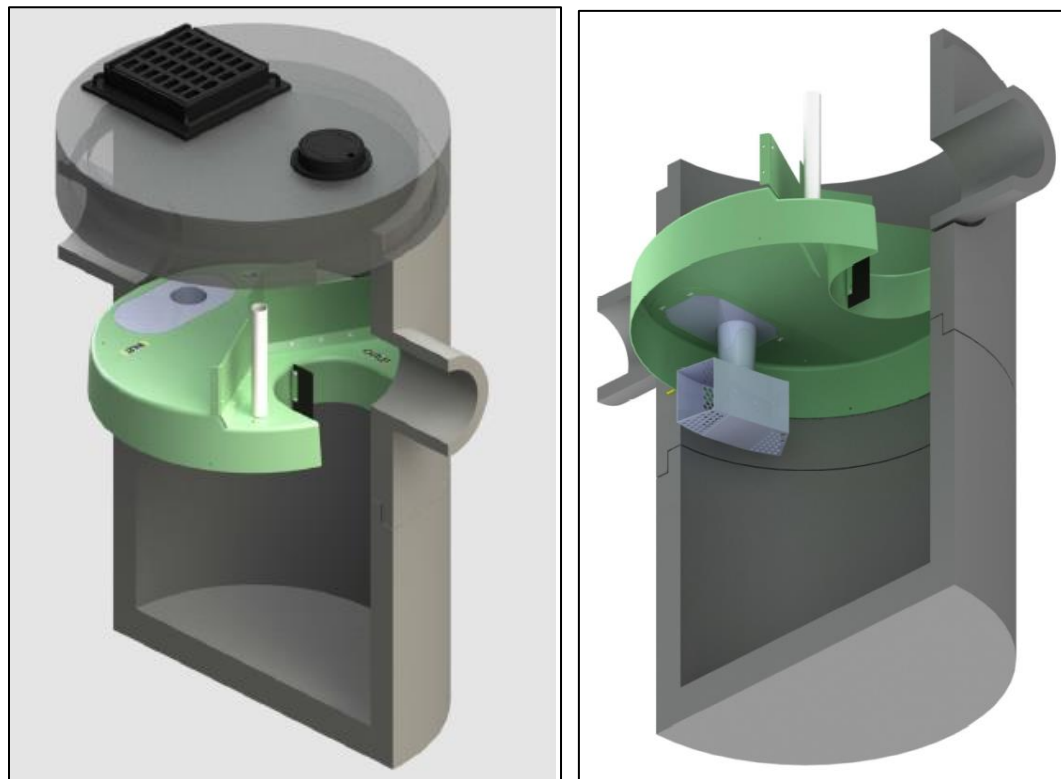

Figure 1. Graphic of typical inline Stormceptor® unit and core components.

Stormwater and snowmelt runoff enters the Stormceptor® EF/EFO's upper chamber through the inlet pipe(s) or a surface inlet grate. An insert divides the unit into lower and upper chambers and incorporates a weir to reduce influent velocity and separate influent (untreated) from effluent (treated) flows. Influent water ponds upstream of the insert's weir providing driving head for the water flowing downwards into the drop pipe where a vortex pulls the water into the lower chamber. The water diffuses at lower velocities in multiple directions through the drop pipe outlet openings. Oil and other floatables rise up and are trapped beneath the insert, while sediments undergo gravitational settling to the sump's bottom. Water from the sump can exit by flowing upward to the outlet riser onto the top side of the insert and downstream of the weir, where it discharges through the outlet pipe.

Maximum flow rate into the lower chamber is a function of weir height and drop pipe orifice diameter. The Stormceptor® EF and EFO are designed to allow a surface loading rate of 1135 L/min/m² (27.9 gal/min/ft²) and 535 L/min/m² (13.1 gal/min/ft²) into the lower chamber, respectively. When prescribed surface loading rates are exceeded, ponding water can overtop the weir height and bypass the lower treatment chamber, exiting directly through the outlet pipe. Hydraulic testing and scour testing demonstrate that the internal bypass effectively prevents scour at all bypass flow rates. Increasing the bypass flow rate does not increase the orifice-controlled flow rate into the lower treatment chamber where sediment is stored. This internal bypass feature allows for in-line installation, avoiding the cost of

additional bypass structures. During bypass, treatment continues in the lower chamber at the maximum flow rate. The Stormceptor® EFO's lower design surface loading rate is favorable for minimizing re-entrainment and washout of captured light liquids. Inspection of Stormceptor® EF and EFO devices is performed from grade by inserting a sediment probe through the outlet riser and an oil dipstick through the oil inspection pipe. The unit can be maintained by using a vacuum hose through the outlet riser.

Performance conditions

The data and results published in this Technology Fact Sheet were obtained from the testing program conducted on the Imbrium Systems Inc.'s Stormceptor® OGS device, in accordance with the Procedure for Laboratory Testing of Oil-Grit Separators (Version 3.0, June 2014). The Procedure was prepared by the Toronto and Region Conservation Authority (TRCA) for Environment Canada's Environmental Technology Verification (ETV) Program. A copy of the Procedure may be accessed on the Canadian ETV website at www.etvcanada.ca.

Performance claim(s)

Capture test^a:

During the capture test, the Stormceptor® EF OGS device, with a false floor set to 50% of the manufacturer's recommended maximum sediment storage depth and a constant influent test sediment concentration of 200 mg/L, removes 70, 64, 54, 48, 46, 44, and 49 percent of influent sediment by mass at surface loading rates of 40, 80, 200, 400, 600, 1000, and 1400 L/min/m², respectively.

Stormceptor® EFO, with a false floor set to 50% of the manufacturer's recommended maximum sediment storage depth and a constant influent test sediment concentration of 200 mg/L, removes 70, 64, 54, 48, 42, 40, and 34 percent of influent sediment by mass at surface loading rates of 40, 80, 200, 400, 600, 1000, and 1400 L/min/m², respectively.

Scour test^a:

During the scour test, the Stormceptor® EF and Stormceptor® EFO OGS devices, with 10.2 cm (4 inches) of test sediment pre-loaded onto a false floor reaching 50% of the manufacturer's recommended maximum sediment storage depth, generate corrected effluent concentrations of 4.6, 0.7, 0, 0.2, and 0.4 mg/L at 5-minute duration surface loading rates of 200, 800, 1400, 2000, and 2600 L/min/m², respectively.

Light liquid re-entrainment test^a:

During the light liquid re-entrainment test, the Stormceptor® EFO OGS device with surrogate low-density polyethylene beads preloaded within the lower chamber oil collection zone, representing a floating light liquid volume equal to a depth of 50.8 mm over the sedimentation area, retained 100, 99.5, 99.8, 99.8, and 99.9 percent of loaded beads by mass during the 5-minute duration surface loading rates of 200, 800, 1400, 2000, and 2600 L/min/m².

^a The claim can be applied to other units smaller or larger than the tested unit as long as the untested units meet the scaling rule specified in the Procedure for Laboratory of Testing of Oil Grit Separators (Version 3.0, June 2014)

Performance results

The test sediment consisted of ground silica (1 – 1000 micron) with a specific gravity of 2.65, uniformly mixed to meet the particle size distribution specified in the testing procedure. The *Procedure for Laboratory Testing of Oil Grit Separators* requires that the three sample average of the test sediment particle size distribution (PSD) meet the specified PSD percent less than values within a boundary threshold of 6%. The comparison of the average test sediment PSD to the CETV specified PSD in Figure 2 indicates that the test sediment used for the capture and scour tests met this condition.

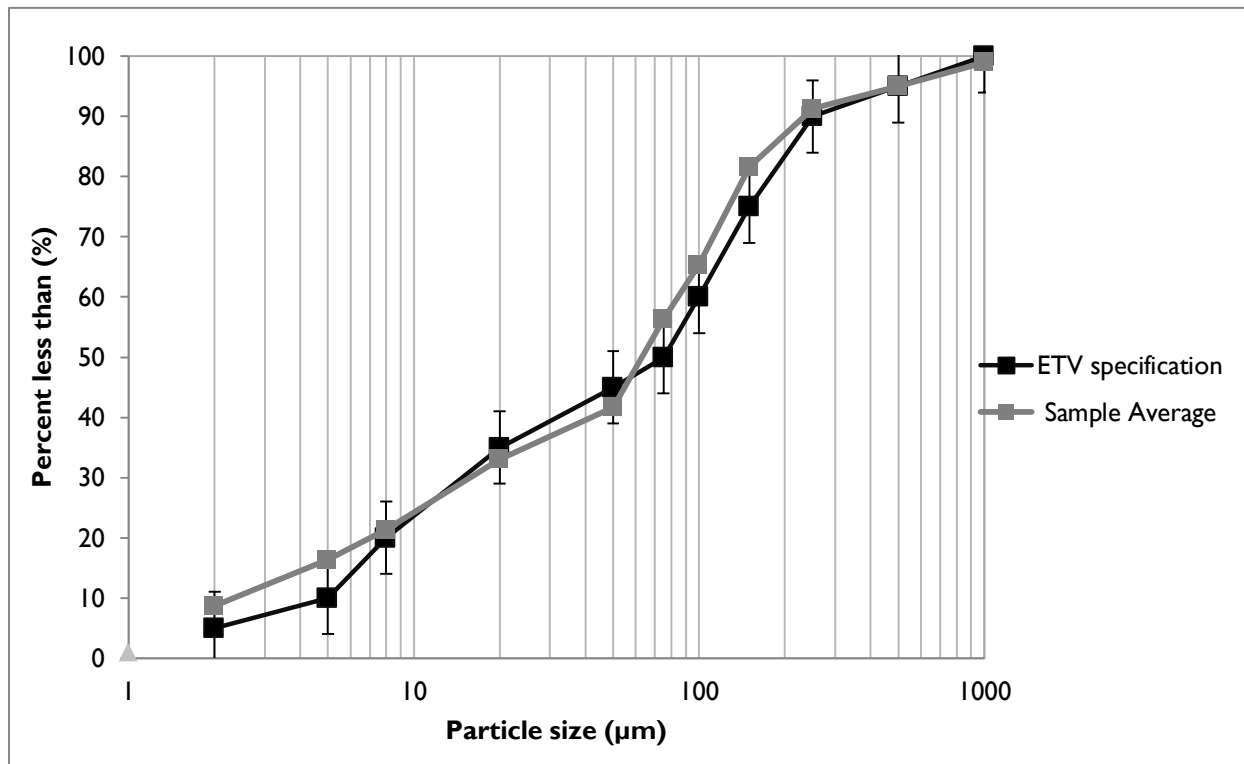

Figure 2. The three sample average particle size distribution (PSD) of the test sediment used for the capture and scour test compared to the specified PSD.

The capacity of the device to retain sediment was determined at seven surface loading rates using the modified mass balance method. This method involved measuring the mass and particle size distribution of the injected and retained sediment for each test run. Performance was evaluated with a false floor simulating the technology filled to 50% of the manufacturer’s recommended maximum sediment storage depth. The test was carried out with clean water that maintained a sediment concentration below 20 mg/L. Based on these conditions, removal efficiencies for individual particle size classes and for the test sediment as a whole were determined for each of the tested surface loading rates (Table 1). Since the EF and EFO models are identical except for the weir height, which bypasses flows from the EFO model at a surface loading rate of 535 L/min/m² (13.1 gpm/ft²), sediment capture tests at surface loading rates from 40 to 400 L/min/m² were only performed on the EF unit. Surface loading rates of 600, 1000, and 1400 L/min/m² were tested on both units separately. Results for the EFO model at these higher flow rates are presented in Table 2.

In some instances, the removal efficiencies were above 100% for certain particle size fractions. These discrepancies are not unique to any one test laboratory and may be attributed to errors relating to the blending of sediment, collection of representative samples for laboratory submission, and laboratory

analysis of PSD. Due to these errors, caution should be exercised in applying the removal efficiencies by particle size fraction for the purposes of sizing the tested device (see [Bulletin # CETV 2016-11-0001](#)). The results for “all particle sizes by mass balance” (see Table 1 and 2) are based on measurements of the total injected and retained sediment mass, and are therefore not subject to blending, sampling or PSD analysis errors.

Table 1. Removal efficiencies (%) of the EF4 at specified surface loading rates

Particle size fraction (µm)	Surface loading rate (L/min/m ²)						
	40	80	200	400	600	1000	1400
>500	90	58	58	100*	86	72	100*
250 - 500	100*	100*	100	100*	100*	100*	100*
150 - 250	90	82	26	100*	100*	67	90
105 - 150	100*	100*	100*	100*	100*	100*	100
75 - 105	100*	92	74	82	77	68	76
53 - 75	Undefined ^a	56	100*	72	69	50	80
20 - 53	54	100*	54	33	36	40	31
8 - 20	67	52	25	21	17	20	20
5 – 8	33	29	11	12	9	7	19
<5	13	0	0	0	0	0	4
All particle sizes by mass balance	70.4	63.8	53.9	47.5	46.0	43.7	49.0

^a An outlier in the feed sample sieve data resulted in a negative removal efficiency for this size fraction.

* Removal efficiencies were calculated to be above 100%. Calculated values ranged between 101 and 171% (average 128%). See text and [Bulletin # CETV 2016-11-0001](#) for more information.

Table 2. Removal efficiencies (%) of the EFO4 at surface loading rates above the bypass rate of 535 L/min/m²

Particle size fraction (µm)	Surface loading rate (L/min/m ²)		
	600	1000	1400
>500	89	83	100*
250 - 500	90	100*	92
150 - 250	90	67	100*
105 - 150	85	92	77
75 - 105	80	71	65
53 - 75	60	31	36
20 - 53	33	43	23
8 - 20	17	23	15
5 – 8	10	3	3
<5	0	0	0
All particle sizes by mass balance	41.7	39.7	34.2

* Removal efficiencies were calculated to be above 100%. Calculated values ranged between 103 and 111% (average 107%). See text and [Bulletin # CETV 2016-11-0001](#) for more information.

Figure 3 compares the particle size distribution (PSD) of the three sample average of the test sediment to the PSD of the sediment retained by the EF4 at each of the tested surface loading rates. Figure 4 shows the same graph for the EFO4 unit at surface loading rates above the bypass rate of 535 L/min/m².

As expected, the capture efficiency for fine particles in both units was generally found to decrease as surface loading rates increased.

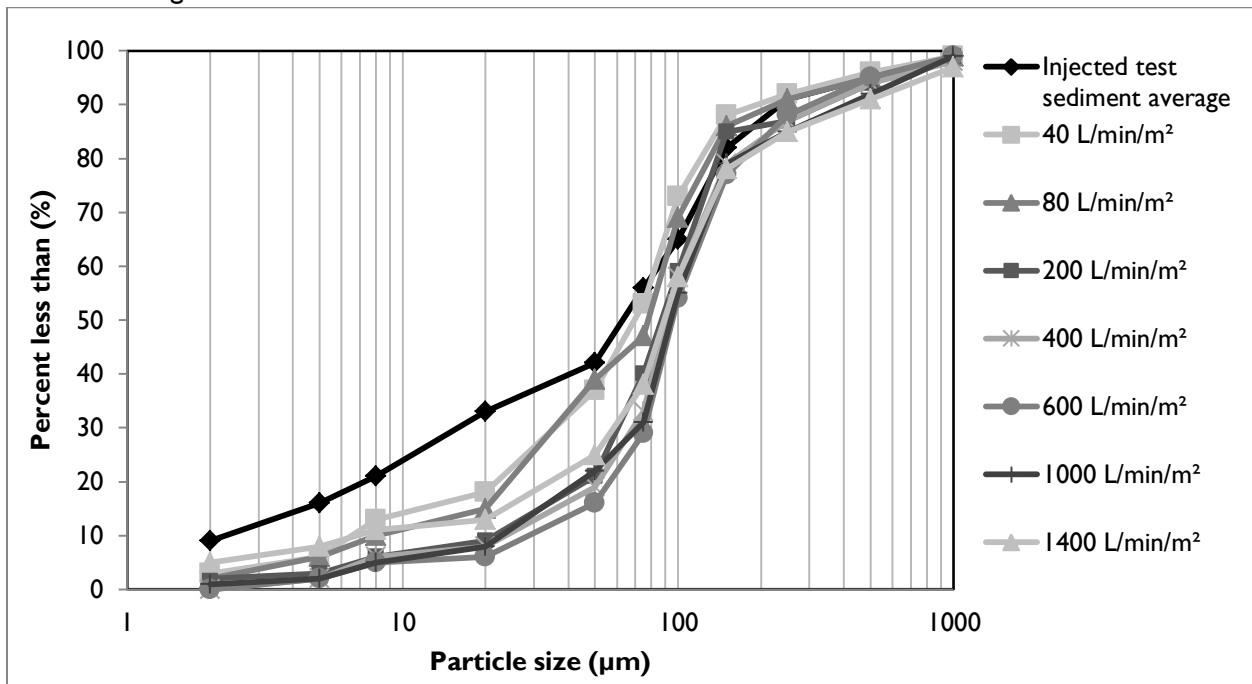

Figure 3. Particle size distribution of sediment retained in the EF4 in relation to the injected test sediment average.

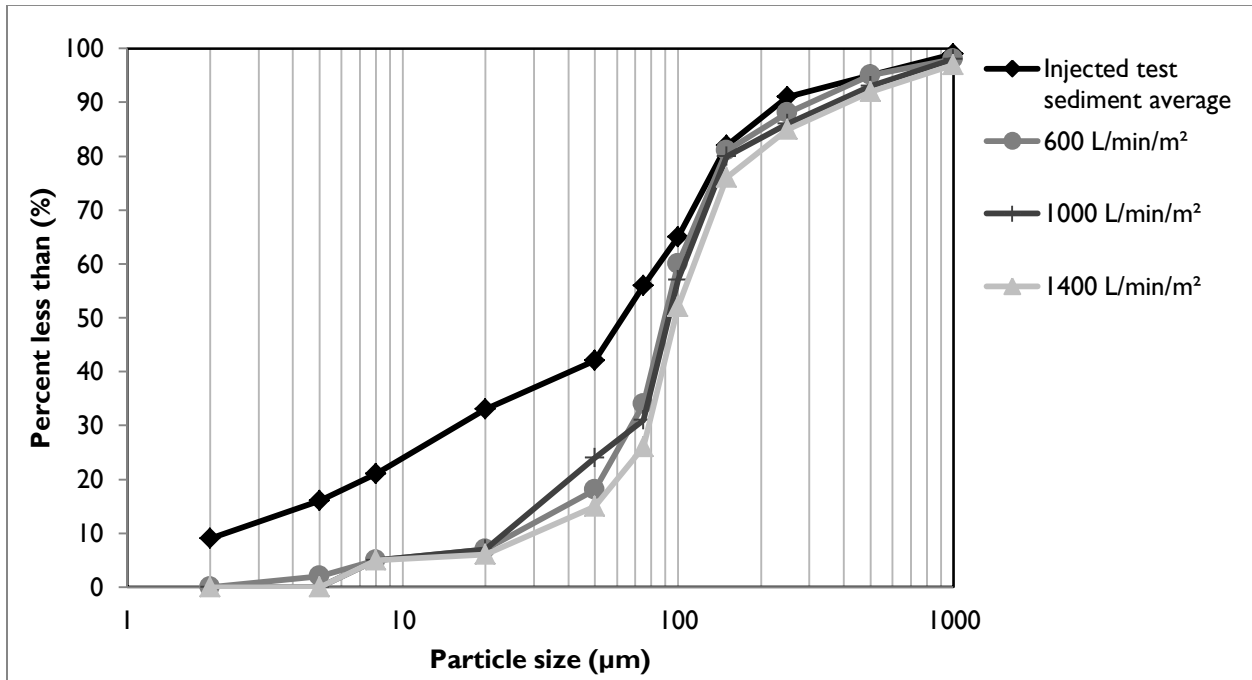

Figure 4. Particle size distribution of sediment retained in the EFO4 in relation to the injected test sediment average at surface loading rates above the bypass rate of 535 L/min/m²

Table 4 shows the results of the sediment scour and re-suspension test for the EF4 unit. The EFO4 was not tested as it was reasonably assumed that scour rates would be lower given that flow bypass occurs at a lower surface loading rate. The scour test involved preloading 10.2 cm of fresh test sediment into

the sedimentation sump of the device. The sediment was placed on a false floor to mimic a device filled to 50% of the maximum recommended sediment storage depth. Clean water was run through the device at five surface loading rates over a 30 minute period. Each flow rate was maintained for 5 minutes with a one minute transition time between flow rates. Effluent samples were collected at one minute sampling intervals and analyzed for Suspended Sediment Concentration (SSC) and PSD by recognized methods. The effluent samples were subsequently adjusted based on the background concentration of the influent water. Typically, the smallest 5% of particles captured during the 40 L/min/m² sediment capture test is also used to adjust the concentration, as per the method described in [Bulletin # CETV 2016-09-0001](#). However, since the composites of effluent concentrations were below the Reporting Detection Limit of the Laser Diffraction PSD methodology, this adjustment was not made. Results showed average adjusted effluent sediment concentrations below 5 mg/L at all tested surface loading rates.

It should be noted that the EF4 starts to internally bypass water at 1135 L/min/m², potentially resulting in the dilution of effluent concentrations, which would not normally occur under typical field conditions because the field influent concentration would contain a much higher sediment concentration than during the lab test. Recalculation of effluent concentrations to account for dilution at surface loading rates above the bypass rate showed sediment effluent concentrations to be below 1.6 mg/L.

Table 4. Scour test adjusted effluent sediment concentration.

Run	Surface loading rate (L/min/m ²)	Run time (min)	Background sample concentration (mg/L)	Adjusted effluent suspended sediment concentration (mg/L) ^a	Average (mg/L)
1	200	1:00	<RDL	11.9	4.6
		2:00		7.0	
		3:00		4.4	
		4:00		2.2	
		5:00		1.0	
		6:00		1.2	
2	800	7:00	<RDL	1.1	0.7
		8:00		0.9	
		9:00		0.6	
		10:00		1.4	
		11:00		0.1	
		12:00		0	
3	1400	13:00	<RDL	0	0
		14:00		0.1	
		15:00		0	
		16:00		0	
		17:00		0	
		18:00		0	
4	2000	19:00	1.2	0.2	0.2
		20:00		0	
		21:00		0	
		22:00		0.7	
		23:00		0	

		24:00		0.4	
5	2600	25:00	1.6	0.3	0.4
		26:00		0.4	
		27:00		0.7	
		28:00		0.4	
		29:00		0.2	
		30:00		0.4	

^a The adjusted effluent suspended sediment concentration represents the actual measured effluent concentration minus the background concentration. For more information see [Bulletin # CETV 2016-09-0001](#).

The results of the light liquid re-entrainment test used to evaluate the unit’s capacity to prevent re-entrainment of light liquids are reported in Table 5. The test involved preloading 58.3 L (corresponding to a 5 cm depth over the collection sump area of 1.17m²) of surrogate low-density polyethylene beads within the oil collection skirt and running clean water through the device continuously at five surface loading rates (200, 800, 1400, 2000, and 2600 L/min/m²). Each flow rate was maintained for 5 minutes with approximately 1 minute transition time between flow rates. The effluent flow was screened to capture all re-entrained pellets throughout the test.

Table 5. Light liquid re-entrainment test results for the EFO4.

Surface Loading Rate (L/min/m ²)	Time Stamp	Amount of Beads Re-entrained			
		Mass (g)	Volume (L) ^a	% of Pre-loaded Mass Re-entrained	% of Pre-loaded Mass Retained
200	62	0	0	0.00	100
800	247	168.45	0.3	0.52	99.48
1400	432	51.88	0.09	0.16	99.83
2000	617	55.54	0.1	0.17	99.84
2600	802	19.73	0.035	0.06	99.94
Total Re-entrained		295.60	0.525	0.91	--
Total Retained		32403	57.78	--	99.09
Total Loaded		32699	58.3	--	--

^a Determined from bead bulk density of 0.56074 g/cm³

Variations from testing Procedure

The following minor deviations from the *Procedure for Laboratory Testing of Oil-Grit Separators* (Version 3.0, June 2014) have been noted:

1. During the capture test, the 40 L/min/m² and 80 L/min/m² surface loading rates were evaluated over 3 and 2 days respectively due to the long duration needed to feed the required minimum of 11.3 kg of test sediment into the unit at these lower flow rates. Pumps were shut down at the end of each intermediate day, and turned on again the following morning. The target flow rate was re-established within 30 seconds of switching on the pump. This procedure may have allowed sediments to be captured that otherwise may have exited the unit if the test was

continuous. On the basis of practical considerations, this variance was approved by the verifier prior to testing.

2. During the scour test, the coefficient of variation (COV) for the lowest flow rate tested (200 L/min/m²) was 0.07, which exceeded the specified limit of 0.04 target specified in the OGS Procedure. A pump capable of attaining the highest flow rate of 3036 L/min had difficulty maintaining the lowest flow of 234 L/min but still remained within +/- 10% of the target flow and is viewed as having very little impact on the observed results. Similarly, for the light liquid re-entrainment test the COV for the flow rate of the 200 L/min/m² run was 0.049, exceeding the limit of 0.04, but is believed to introduce negligible bias.
3. Due to pressure build up in the filters, the runs at 1000 L/min/m² for the Stormceptor® EF4 and 1000 and 1400 L/min/m² for the Stormceptor® EFO4 were slightly shorter than the target. The run times were 54, 59 and 43 minutes respectively, versus targets of 60 and 50 minutes. The final feed samples were timed to coincide with the end of the run. Since >25 lbs of sediment was fed, the shortened time did not invalidate the runs.

Verification

The verification was completed by the Verification Expert, Toronto and Region Conservation Authority, contracted by GLOBE Performance Solutions, using the International Standard **ISO 14034:2016 Environmental management – Environmental technology verification (ETV)**. Data and information provided by Imbrium Systems Inc. to support the performance claim included the following: Performance test report prepared by Good Harbour Laboratories, and dated September 8, 2017; the report is based on testing completed in accordance with the Procedure for Laboratory Testing of Oil-Grit Separators (Version 3.0, June 2014).

What is ISO 14034:2016 Environmental management – Environmental technology verification (ETV)?

ISO 14034:2016 specifies principles, procedures and requirements for environmental technology verification (ETV), and was developed and published by the *International Organization for Standardization (ISO)*. The objective of ETV is to provide credible, reliable and independent verification of the performance of environmental technologies. An environmental technology is a technology that either results in an environmental added value or measures parameters that indicate an environmental impact. Such technologies have an increasingly important role in addressing environmental challenges and achieving sustainable development.

For more information on the Stormceptor® EF4 and EFO4 please contact:

Imbrium Systems, Inc.
407 Fairview Drive
Whitby, ON
L1N 3A9, Canada
Tel: 416-960-9900
info@imbriumsystems.com

For more information on ISO 14034:2016 / ETV please contact:

GLOBE Performance Solutions
World Trade Centre
404 – 999 Canada Place
Vancouver, BC
V6C 3E2 Canada
Tel: 604-695-5018 / Toll Free: 1-855-695-5018
etv@globeperformance.com

Limitation of verification

GLOBE Performance Solutions and the Verification Expert provide the verification services solely on the basis of the information supplied by the applicant or vendor and assume no liability thereafter. The responsibility for the information supplied remains solely with the applicant or vendor and the liability for the purchase, installation, and operation (whether consequential or otherwise) is not transferred to any other party as a result of the verification.

CSO/STORMWATER MANAGEMENT



HYDROVEX[®] VHV / SVHV
Vertical Vortex Flow Regulator

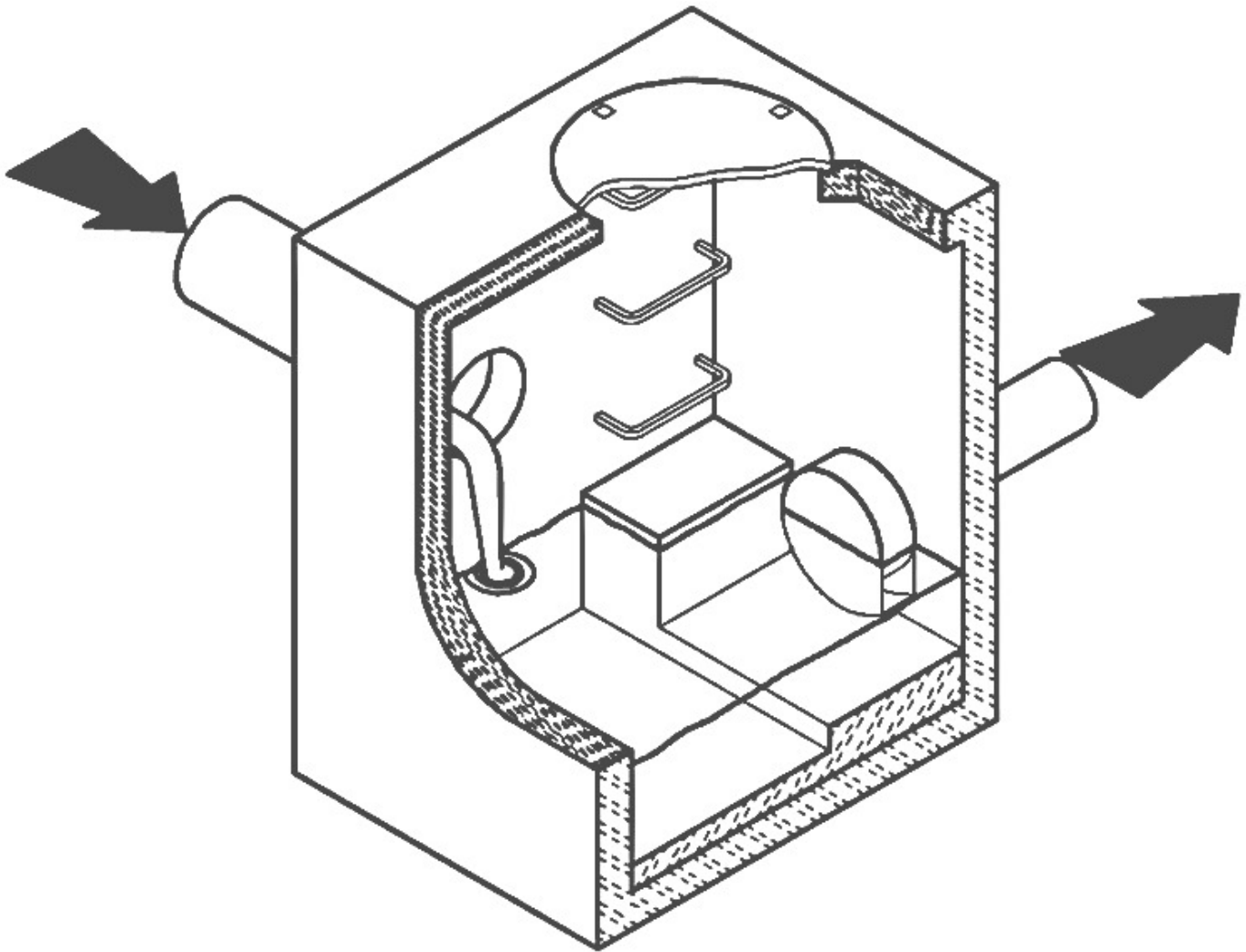

JOHN MEUNIER

HYDROVEX® VHV / SVHV VERTICAL VORTEX FLOW REGULATOR

APPLICATIONS

One of the major problems of urban wet weather flow management is the runoff generated after a heavy rainfall. During a storm event, uncontrolled flows may overload the drainage system and cause flooding. Sewer pipe wear and network deterioration are increased dramatically as a result of increased flow velocities. In a combined sewer system, the wastewater treatment plant will experience a significant increase in flows during storms, thereby losing its treatment efficiency.

A simple means of managing excessive water runoff is to control excessive flows at their point of origin, the manhole. **John Meunier Inc.** manufactures the **HYDROVEX® VHV / SVHV** line of vortex flow regulators for point source control of stormwater flows in sewer networks, as well as manholes, catch basins and other retention structures.

The **HYDROVEX® VHV / SVHV** design is based on the fluid mechanics principle of the forced vortex. The discharge is controlled by an air-filled vortex which reduces the effective water passage area without physically reducing orifice size. This effect grants precise flow regulation without the use of moving parts or electricity, thus minimizing maintenance. Although the concept is quite simple, over 12 years of research and testing have been invested in our vortex technology design in order to optimize its performance.

The **HYDROVEX® VHV / SVHV** Vertical Vortex Flow Regulators (refer to **Figure 1**) are manufactured entirely of stainless steel, and consist of a hollow body (1) (in which flow control takes place) and an outlet orifice (7). Two rubber "O" rings (3) seal and retain the unit inside the outlet pipe. Two stainless steel retaining rings (4) are welded on the outlet sleeve to ensure that there is no shifting of the "O" rings during installation and operation.

1. BODY
2. SLEEVE
3. O-RING
4. RETAINING RINGS
(SQUARE BAR)
5. ANCHOR PLATE
6. INLET
7. OUTLET ORIFICE

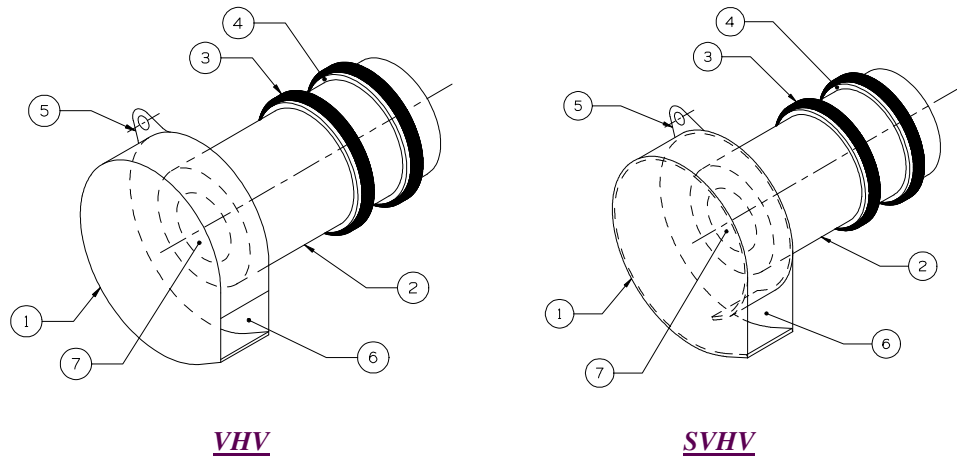

FIGURE 1: HYDROVEX® VHV-SVHV VERTICAL VORTEX FLOW REGULATORS

ADVANTAGES

- As a result of the air-filled vortex, a **HYDROVEX® VHV / SVHV** flow regulator will typically have an opening 4 to 6 times larger than an orifice plate. Larger opening sizes decrease the chance of blockage caused by sediments and debris found in stormwater flows. **Figure 2** shows the discharge curve of a vortex regulator compared to an equally sized orifice plate. One can see that for the same height of water and same opening size, the vortex regulator controls a flow approximately four times smaller than the orifice plate.
- Having no moving parts, they require minimal maintenance.
- Submerged inlet for floatables control.
- The **HYDROVEX® VHV / SVHV** line of flow regulators are manufactured entirely of stainless steel, making them durable and corrosion resistant.
- Installation of the **HYDROVEX® VHV / SVHV** flow regulators is quick and straightforward and is performed after all civil works are completed.
- Installation requires no assembly, special tools or equipment and may be carried out by any contractor.

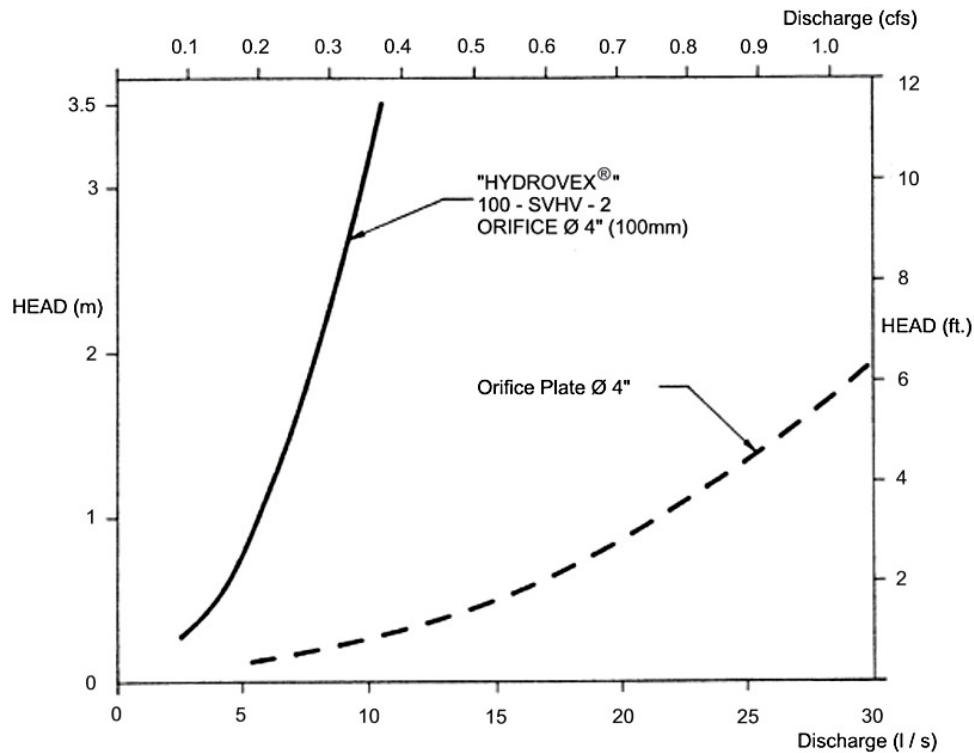

FIGURE 2: DISCHARGE CURVE SHOWING A HYDROVEX® FLOW REGULATOR VS AN ORIFICE PLATE

SELECTION

Selecting a **VHV** or **SVHV** regulator is easily achieved using the selection chart found at the end of this brochure (refer to **Figure 3**). Each selection is made using the maximum allowable discharge rate and the maximum allowable water pressure (head) retained upstream from the regulator. The area in which the design point falls will designate the required VHV/SVHV model. The maximum design head is calculated as the difference between the maximum upstream water level and the invert of the outlet pipe. All selections should be verified by a John Meunier Inc. representative prior to fabrication.

Example:

- ✓ Maximum discharge 6 L/s (0.2 cfs)**
- ✓ Maximum design head 2m (6.56 ft.)
- ✓ Using **Figure 3** model required is a **75 VHV-1**

** It is important to verify the capacity of the manhole/catch basin outlet pipe. Should the outlet pipe be >80% full at design flow, the use of an air vent is required.

INSTALLATION REQUIREMENTS

HYDROVEX® VHV / SVHV flow regulators can be installed in circular or square manholes. **Figure 4** lists the minimum dimensions required for each regulator model. *It is imperative to respect the minimum clearances shown to ensure ease of installation and proper functioning of the regulator.*

SPECIFICATIONS

In order to specify a **HYDROVEX® VHV/SVHV** flow regulator, the following parameters must be clearly indicated:

- The model number (ex: 75-VHV-1)
- The diameter and type of outlet pipe (ex: \varnothing 6", SDR 35)
- The maximum discharge rate (ex: 6.0 L/s [0.21 CFS])
- The maximum upstream head (ex: 2.0 m [6.56 ft]) *
- The manhole diameter (ex: \varnothing 900 mm [\varnothing 36"])
- The minimum clearance "H" (ex: 150 mm [6 in]) as indicated in **Figure 4**
- The material type (ex: 304 stainless steel, standard)

* *Upstream head is defined as the difference in elevation between the maximum upstream water level and the invert of the outlet pipe where the **HYDROVEX®** flow regulator is to be installed.*

PLEASE NOTE THAT WHEN REQUESTING A PROPOSAL, WE SIMPLY REQUIRE THAT YOU PROVIDE US WITH THE FOLLOWING INFORMATION:

- *project design flow rate*
- *pressure head*
- *chamber's outlet pipe diameter and type*



*Typical **HYDROVEX®** VHV model*

OPTIONS



VHV-1-O
(extended inlet for odor control)



FV-VHV
(mounted on sliding plate for emergency bypass)



VHV with Gooseneck assembly
(manhole without clearance below regulator)

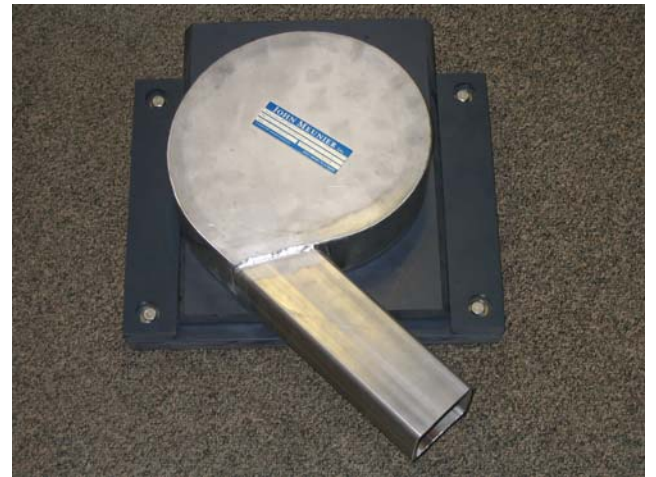

FV-VHV-O
(sliding plate with extended inlet)



VHV with upstream air vent
(applications where outlet pipe is > 80% full at peak flow)



VHV/SVHV Vortex Flow Regulator

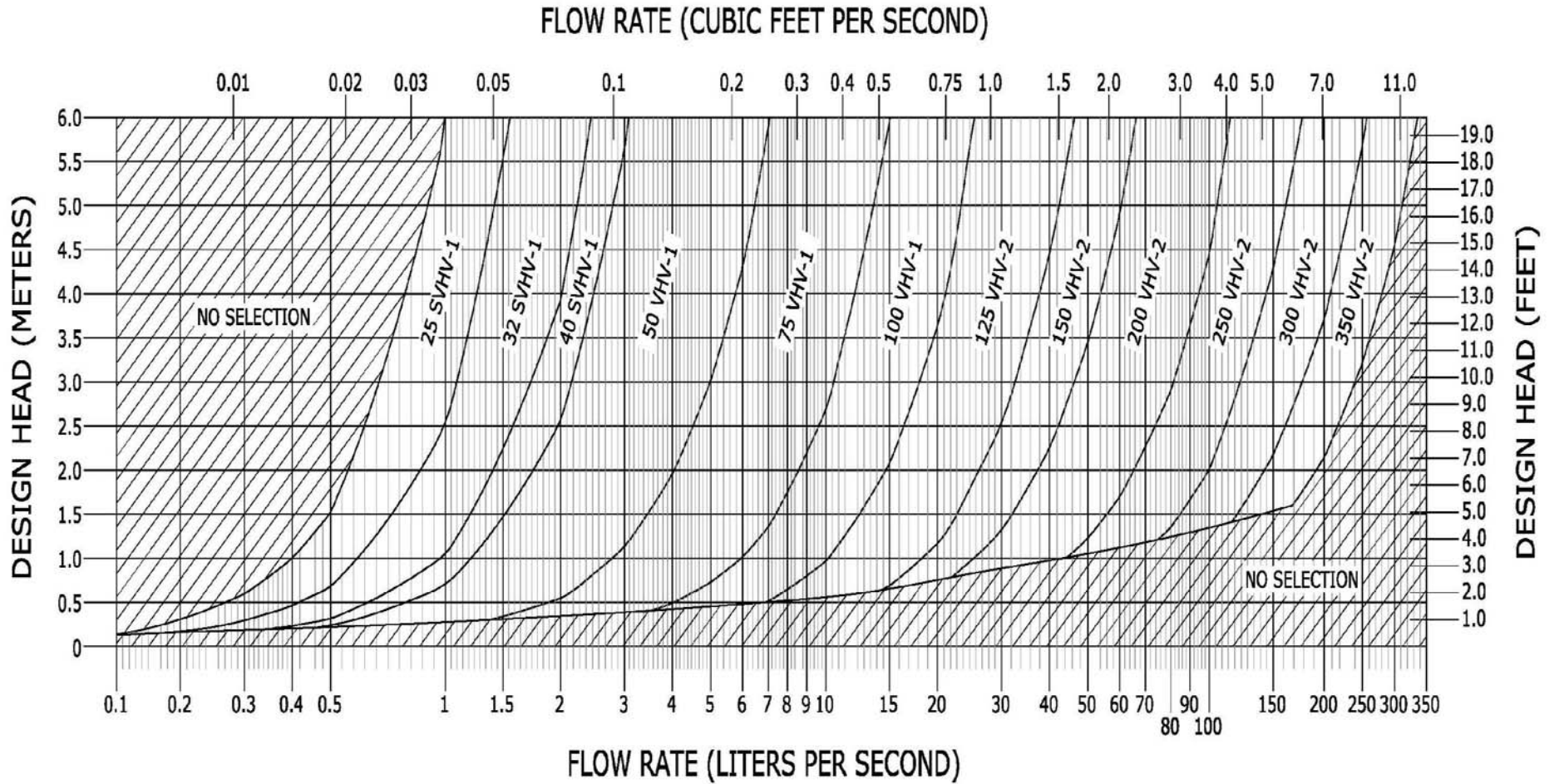

FIGURE 3

JOHN MEUNIER

**TYPICAL INSTALLATION OF A VORTEX FLOW REGULATOR IN
A CIRCULAR OR SQUARE/RECTANGULAR MANHOLE
FIGURE 4**

Model	Regulator Diameter A (mm) [in]	<u>CIRCULAR</u>	<u>SQUARE</u>	Minimum Outlet Pipe Diameter C (mm) [in]	Minimum Clearance H (mm) [in]
		Minimum Manhole Diameter B (mm) [in]	Minimum Chamber Width B (mm) [in]		
25 SVHV-1	125 [5]	600 [24]	600 [24]	150 [6]	150 [6]
32 SVHV-1	150 [6]	600 [24]	600 [24]	150 [6]	150 [6]
40 SVHV-1	200 [8]	600 [24]	600 [24]	150 [6]	150 [6]
50 VHV-1	150 [6]	600 [24]	600 [24]	150 [6]	150 [6]
75 VHV-1	250 [10]	600 [24]	600 [24]	150 [6]	150 [6]
100 VHV-1	325 [13]	900 [36]	600 [24]	150 [6]	200 [8]
125 VHV-2	275 [11]	900 [36]	600 [24]	150 [6]	200 [8]
150 VHV-2	350 [14]	900 [36]	600 [24]	150 [6]	225 [9]
200 VHV-2	450 [18]	1200 [48]	900 [36]	200 [8]	300 [12]
250 VHV-2	575 [23]	1200 [48]	900 [36]	250 [10]	350 [14]
300VHV-2	675 [27]	1600 [64]	1200 [48]	250 [10]	400 [16]
350VHV-2	800 [32]	1800 [72]	1200 [48]	300 [12]	500 [20]

Circular Manhole

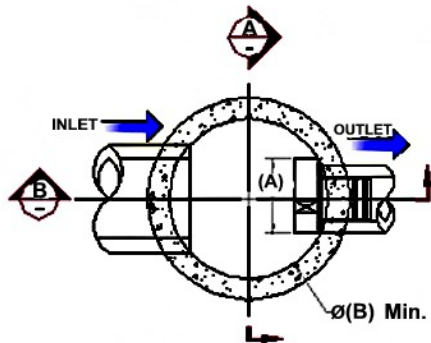

CIRCULAR WELL

Square / Rectangular Manhole

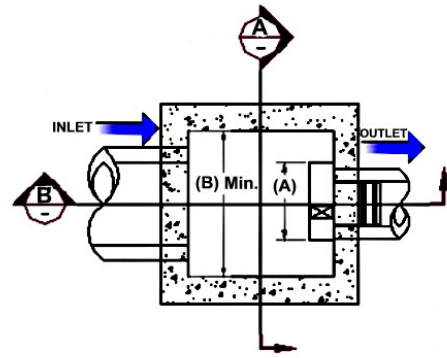

SQUARE / RECTANGULAR WELL

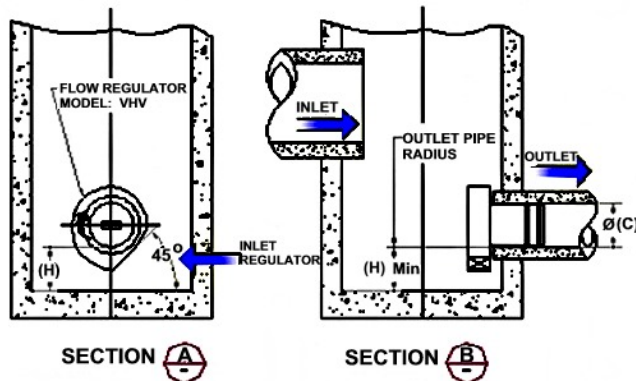

SECTION A

SECTION B

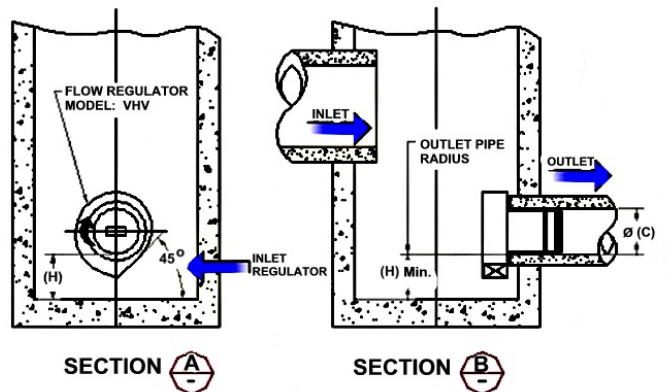

SECTION A

SECTION B

NOTE: *In the case of a square manhole, the outlet pipe must be centered on the wall to ensure that there is enough clearance for installation of the regulator.*

INSTALLATION

The installation of a **HYDROVEX**[®] regulator may begin once the manhole and piping are in place. Installation consists of simply sliding the regulator into the outlet pipe of the manhole and securing it to the wall with an anchor (supplied). **John Meunier Inc.** recommends applying a lubricant on the inner surface of the outlet pipe, in order to facilitate the insertion and the manipulation of the flow controller.

MAINTENANCE

HYDROVEX[®] regulators are designed and manufactured to minimize maintenance requirements. We recommend a periodic visual inspection every 3-6 months (depending on local flow and sediment conditions) in order to ensure that neither the inlet nor the outlet has become blocked with debris. The manhole housing the vortex regulator should be inspected and cleaned with a vacuum truck periodically, especially after major storm events.

GUARANTY

The **HYDROVEX**[®] line of **VHV / SVHV** regulators are guaranteed against both design and manufacturing defects for a period of 5 years after sale. Should a flow regulator be found to be defective within the guarantee period, **John Meunier Inc.** will modify or replace the defective unit.

John Meunier Inc.

ISO 9001 : 2008

Head Office

4105 Sartelon
Saint-Laurent (Quebec) Canada H4S 2B3
Tel.: 514-334-7230 www.johnmeunier.com
Fax: 514-334-5070 cs@johnmeunier.com

Ontario Office

2000 Argenta Road, Plaza 4, Unit 430
Mississauga (Ontario) Canada L5N 1W1
Tel.: 905-286-4846 www.johnmeunier.com
Fax: 905-286-0488 ontario@johnmeunier.com

USA Office

2209 Menlo Avenue
Glenside, PA USA 19038
Tel.: 412- 417-6614 www.johnmeunier.com
Fax: 215-885-4741 asteele@johnmeunier.com



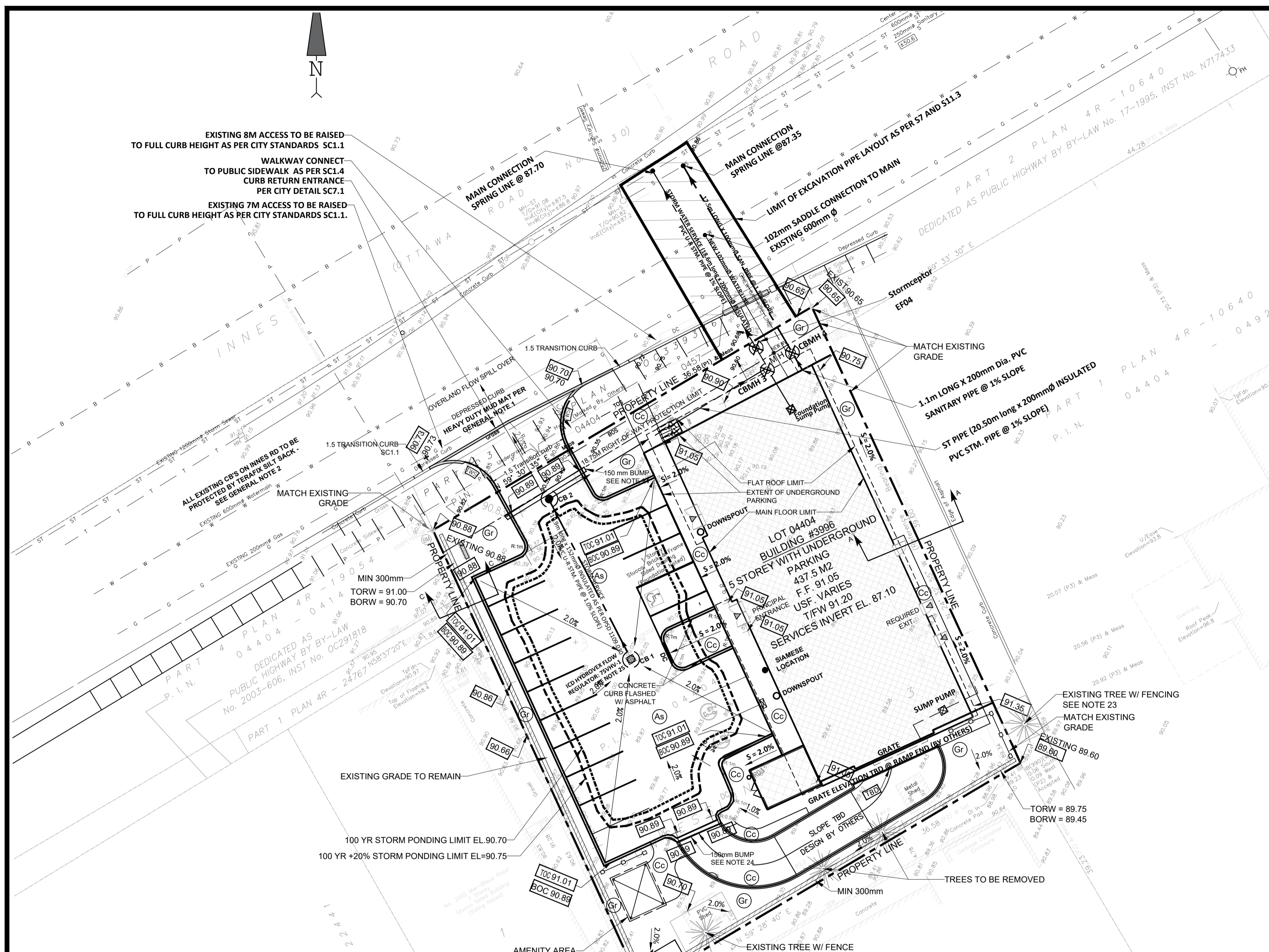
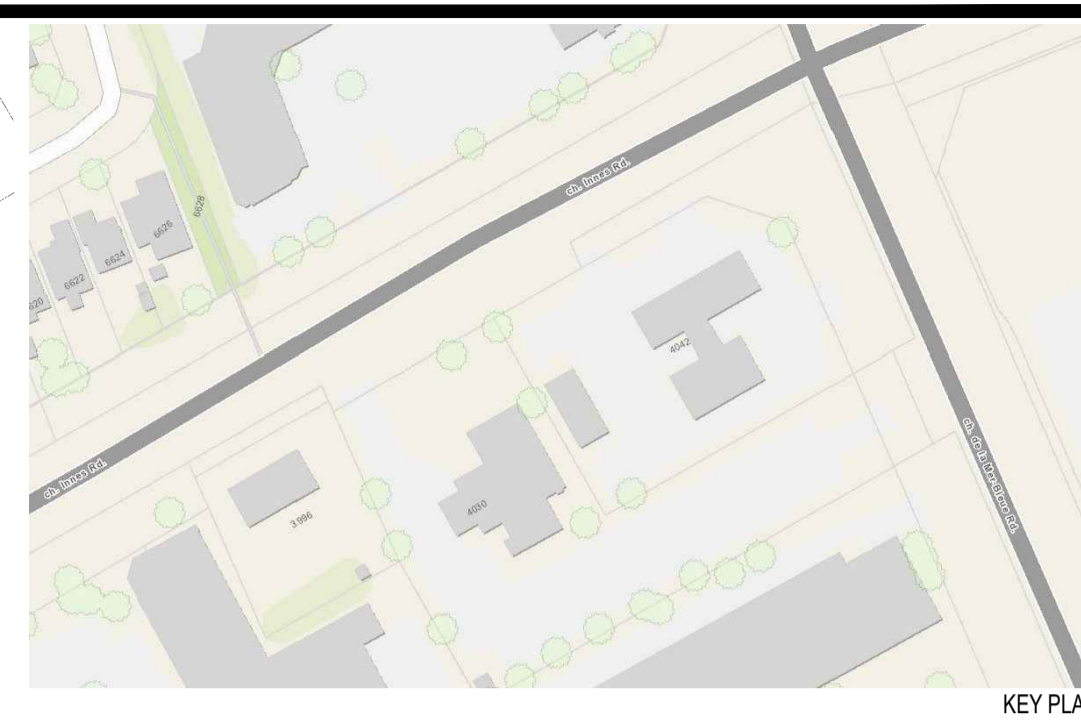

NOTES FOR SERVICING

1. ALL SERVICES, MATERIALS, CONSTRUCTION METHODS AND INSTALLATIONS SHALL BE IN ACCORDANCE WITH THE LATEST STANDARDS AND REGULATIONS FOR THE CITY OF OTTAWA STANDARD SPECIFICATION AND DRAWINGS, ONTARIO PROVINCIAL STANDARD DRAWINGS (OPSD), UNLESS OTHERWISE SPECIFIED, TO THE SATISFACTION OF THE CITY AND THE CONSULTANT.
2. THE POSITION OF EXISTING POLE LINES, CONDUITS, WATER MAINS SEWERS AND OTHER UNDERGROUND AND ABOVEGROUND UTILITIES, STRUCTURES AND APPURTENANCES OF THE POSITION OF SUCH UTILITIES AND STRUCTURES IS NOT GUARANTEED. PRIOR TO CONSTRUCTION, THE CONTRACTOR SHALL SATISFY HIMSELF OF THE EXACT LOCATION OF ALL SUCH UTILITIES AND STRUCTURES AND SHALL ASSUME LIABILITY FOR DAMAGE TO THEM DURING THE COURSE OF CONSTRUCTION. ANY RELOCATION OF EXISTING UTILITIES REQUIRED BY THE DEVELOPMENT OF SUBJECT LANDS IS TO BE UNDERTAKEN AT THE CONTRACTOR'S EXPENSE.
3. THE CONTRACTOR MUST NOTIFY ALL EXISTING UTILITY COMPANY OFFICIALS FIVE (5) BUSINESS DAYS PRIOR TO THE START OF CONSTRUCTION AND HAVE ALL EXISTING UTILITIES AND SERVICES LOCATED IN THE FIELD OR EXPOSED PRIOR TO THE START OF CONSTRUCTION, INCLUDING BUT NOT LIMITED TO HYDRO, BELL, CABLE, TV, AND CONSUMERS GAS LINES.
4. ALL TRENCHING AND EXCAVATIONS ARE TO BE IN ACCORDANCE WITH THE LATEST REVISIONS OF THE OCCUPATIONAL HEALTH AND SAFETY ACT AND REGULATIONS FOR CONSTRUCTION PROJECTS.
5. REFER TO ARCHITECT PLANS FOR BUILDING DIMENSIONS LAYOUT AND REMOVALS. REFER TO LANDSCAPE PLAN FOR LANDSCAPED DETAILS AND OTHER RELEVANT INFORMATION. THE INFORMATION SHALL BE CONFIRMED PRIOR TO COMMENCEMENT OF CONSTRUCTION.
6. TOPOGRAPHIC SURVEY COMPLETED ON THE 8TH DAY OF JANUARY 2021 AND PROVIDED BY FARLEY, SMITH & DENIS SURVEYING LTD. CONSTRUCTION TO VERIFY IN THE FIELD PRIOR TO CONSTRUCTION AND NOTIFY THE ENGINEER OF ANY DISCREPANCIES.
7. THE LOCATION OF UNDERGROUND SERVICES IS BASED ON THE SURVEY PROVIDED WITH THE INFORMATION FROM THE CITY OF OTTAWA. HOWEVER, THE CONTRACTOR MUST ENSURE THAT THIS INFORMATION IS VERIFIED PRIOR TO CONSTRUCTION AND NOTIFY THE ENGINEER IMMEDIATELY OF ANY DISCREPANCIES.
8. ALL ELEVATIONS ARE GEODETIC AND UTILIZED METRIC UNITS.
9. BENCHMARK AS INDICATED ON THE DRAWINGS.
10. ALL GROUND SURFACES SHALL BE EVENLY GRADED WITHOUT PONDING AREAS AND WITHOUT LOW POINTS EXCEPT APPROVED SWALE OR CATCH BASIN OUTLETS ARE PROVIDED.
11. ALL EDGES OF THE DISTURBED PAVEMENT SHALL BE SAW CUT TO FORM A NEAT AND STRAIGHT LINE PRIOR TO PLACING NEW PAVEMENT. PAVEMENT REINSTATEMENT SHALL BE WITH STEP JOINTS OF 500MM WIDTH MINIMUM.
12. ALL DISTURBED AREAS OUTSIDE PROPOSED GRADING LIMITS ARE TO BE RESTORED TO ORIGINAL ELEVATIONS AND CONDITIONS UNLESS OTHERWISE SPECIFIED. ALL RESTORATION SHALL BE COMPLETED WITH THE GEOTECHNICAL REQUIREMENTS FOR BACKFILL AND COMPACTION.
13. ALL MATERIAL SUPPLIED AND PLACED FOR PARKING LOT AND ACCESS ROAD CONSTRUCTION SHALL BE TO OPSD STANDARDS AND SPECIFICATIONS UNLESS OTHERWISE NOTED. CONSTRUCTION TO OPSD 206, 310 & 314. MATERIAL TO OPSD 1001, 1003 & 1010.
14. ABUTTING PROPERTY GRADES TO BE MATCHED.
15. THE CONTRACTOR SHALL OBTAIN AND PAY FOR ALL NECESSARY PERMITS AND APPROVALS FROM THE MUNICIPAL AUTHORITIES PRIOR TO COMMENCING CONSTRUCTION.
16. MINIMIZE DISTURBANCE TO EXISTING VEGETATION DURING THE EXECUTION OF ALL WORKS.
17. REMOVE FROM THE SITE ALL EXCESS EXCAVATED MATERIAL, UNLESS OTHERWISE DIRECTED BY THE ENGINEER. EXCAVATE AND REMOVE ALL ORGANIC MATERIAL AND DEBRIS LOCATED WITHIN THE PROPOSED BUILDING, PARKING AND ROADWAY LOCATIONS.
18. ALL PROPOSED UTILITIES CONNECTION POINTS AND CROSSINGS (I.E. STORM SEWER, SANITARY SEWER, WATER, ETC.) THE CONTRACTOR SHALL DETERMINE THE PRECISE LOCATION AND DEPTH OF EXISTING UTILITIES AND REPORT ANY DISCREPANCIES OR CONFLICTS TO THE ENGINEER BEFORE COMMENCING WORK.
19. SERVICE TRENCHES ON MUNICIPAL RIGHT OF WAY ARE TO BE REINSTATED AS PER CITY OF OTTAWA DETAIL R10.
20. PRIOR TO CONSTRUCTION, A GEOTECHNICAL ENGINEER REGISTERED IN THE PROVINCE OF ONTARIO IS TO INSPECT ALL SUB-SURFACES FOR FOOTINGS, SERVICES AND PAVEMENT STRUCTURES. FOR ANY SOILS RELATED INFORMATION, REFER TO THE GEOTECHNICAL INVESTIGATION REPORT.
21. CONTRACTOR TO REINSTATE PAVER STONES IN CITY ROW.
22. PAVEMENT STRUCTURE SHALL CONSIST OF:

Thickness (mm)	Material Description
40	Wear Course - HL-3 or Superpave 12.5 Asphaltic Concrete
50	Wear Course - HL-8 or Superpave 19 Asphaltic Concrete
150	Base - OPSS Granular A Crushed Stone
450	Subbase - OPSS Granular B Type II

 Subgrade - Either fill in-situ soil, or OPSS Granular B Type I or II material placed over in-situ soil, bedrock or concrete fill.

23. PLEASE REFER TO MAP 1, 2 IFS FOR TREE ID, CONDITION AND ACTION
24. ALLOWABLE FLOW DEPTHS ARE: 350MM FOR LOCAL, 250MM FOR COLLECTOR, 150MM FOR ARTERIAL ROADS AS PER CITY DRAWING S.17.
25. THE PROPOSED ICD SHALL BE A SLIDE TYPE AS PER CITY GUIDELINES.

NOTES FOR WATER MAIN

1. ALL WATER MAIN AND WATER MAIN APPURTENANCES, MATERIALS, CONSTRUCTION AND TESTING METHODS SHALL CONFORM TO THE CURRENT CITY OF OTTAWA AND THE MINISTRY OF ENVIRONMENTAL STANDARDS AND SPECIFICATIONS.
2. ALL WATER MAIN 300MM DIAMETER AND SMALLER TO BE POLYVINYL CHLORIDE (PVC) CLASS 150 OR 18 MEETINGS AWWA SPECIFICATION C900. STANDARD LATERAL MATERIAL SERVICES UP TO 50MM IS COPPER TYPE "K".
3. ALL WATER MAINS ARE TO BE INSTALLED AT A MINIMUM COVER OF 2.4M BELOW THE FINISHED GRADE, WHERE WATER MAINS CROSS OVER OTHER UTILITIES. A MINIMUM 0.30M CLEARANCE FROM UTILITIES OVERT SHALL BE MAINTAINED, WHERE WATER MAINS CROSS UNDER OTHER UTILITIES, A MINIMUM OF 0.50M, CLEARANCE SHALL BE MAINTAINED, WHERE THE MINIMUM SEPARATION CANNOT BE ACHIEVED, THE WATER MAIN SHALL BE INSTALLED AS PER THE CITY OF OTTAWA STANDARDS W25 AND W25.2. WHERE A 2.4M MINIMUM DEPTH CANNOT BE ACHIEVED, THERMAL INSULATION SHALL BE PROVIDED AS PER THE CITY OF OTTAWA STANDARD W22.
4. WATER MAIN BEDDING TO BE AS PER CITY OF OTTAWA STANDARD W17.
5. VALVE BOX TO BE AS PER CITY OF OTTAWA STANDARD W24.
6. CONCRETE THRUST BLOCKS AND MECHANICAL RESTRAINTS ARE TO BE INSTALLED AT ALL TEES, BENDS, HYDRANTS, REDUCERS, END OF MAINS AND CONNECTIONS 100MM AND LARGER, IN ACCORDANCE WITH THE CITY OF OTTAWA STANDARD W25 AND W25.4.
7. CATHODIC PROTECTION IS REQUIRED FOR ALL IRON FITTING AS PER THE CITY OF OTTAWA STANDARDS W40 & W42.
8. FIRE HYDRANTS TO BE AS PER CITY OF OTTAWA STANDARD W19. (NOT REQUIRED).
9. IF THE WATER MAIN MUST BE DEFLECTED TO MEET ALIGNMENT, ENSURE THAT THE AMOUNT OF DEFLECTION USED IS LESS THAN HALF THAT RECOMMENDED BY THE MANUFACTURER. TYPICAL WATER SERVICE LINE AS PER W20 (FOR 100MM & 250MM DIAM WATER SERVICES), AND TO BE INSTALLED AT 1M FROM THE FOUNDATION WALLS.

NOTES: SEWER AND MANHOLES

10. ALL SANITARY SEWER, SANITARY SEWER APPURTENANCE AND CONSTRUCTION METHODS SHALL CONFORM TO THE CURRENT CITY OF OTTAWA STANDARDS AND SPECIFICATIONS.
11. SEWER BEDDING SHALL BE AS PER CITY OF OTTAWA DETAIL S6.
12. ALL WORK SHALL BE PERFORMED AS APPLICABLE IN ACCORDANCE WITH OPSD 407 AND 410.
13. ALL SANITARY MANHOLES 1200mm IN DIAMETER TO BE AS PER OPSD 701.01, FRAME AND COVER TO BE AS PER STANDARD S25 AND S25.4.
14. SANITARY BACKWATER VALVES ARE TO BE PROVIDED FOR EACH BUILDING CLOSE TO THE FOUNDATION WALL NEAR SERVICES ENTRY AS PER CITY OF OTTAWA STD S14.1 OR S14.2.
15. STORM BACKWATER VALVES ARE TO BE PROVIDED CLOSE TO THE FOUNDATION WALL NEAR SERVICES ENTRY AS PER THE CITY OF OTTAWA STD S14.
16. ALL STORM SEWER MATERIALS AND CONSTRUCTION METHODS SHALL CONFORM TO THE CURRENT CITY OF OTTAWA STANDARDS AND SPECIFICATIONS.
17. Gas main shall be 1.0m of separation from watermain as per P20.

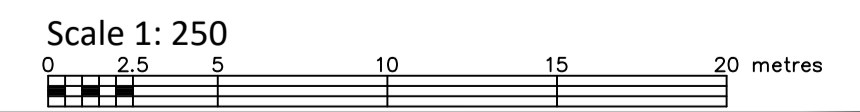

GENERAL NOTES & LEGEND:

- PROPERTY LINE
- SILT FENCE PER OPSD 219.130
- PROPOSED BUILDING ENVELOPE
- EXISTING FIRE HYDRANT
- PROPOSED CONCRETE CURB WITH DEPRESSION
- EXISTING HYDRO POLE
- EXISTING GROUND ELEVATION
- PROPOSED DOOR ENTRANCE
- DIRECTION AND SLOPE OF SURFACE WATER FLOW
- PROPOSED FINISHED FLOOR ELEVATION
- PROPOSED UNDERSIDE OF FOOTING ELEVATION
- SITE BENCHMARK SITE BENCHMARK 2 NAILS IN UTILITY POLE ELEVATION=91.06
- PROPOSED TOP OF RETAINING WALL
- PROPOSED BOTTOM OF RETAINING WALL
- 100 YEAR STORM PONDING LIMIT CONTOUR LINE
- 100 YEAR + 20% STORM PONDING LIMIT CONTOUR LINE
- ASPHALT
- CONCRETE
- GRASS
- TREE

1. HEAVY DUTY MUD MAT IS REQUIRED AT SITE ENTRANCE
2. ALL CB TO BE PROTECTED WITH TERAFIX SILT SACK
3. CONCRETE BARRIER CURB PER OPSD 600.110
4. SEWER/STORM LATERAL CONNECTIONS PER OPSD 1006.020
5. THE CONTRACTOR IS REQUIRED TO GET WRITTEN PERMISSION FROM ADJACENT PROPERTY OWNERS FOR WORK OUTSIDE THE PROPERTY LINE.
6. HEAVY DUTY SILT FENCE PER OPSD 219.136.
7. THE FOLLOWING DOCUMENTS HAVE BEEN REVIEWED:
 - CITY OF OTTAWA STANDARD TENDER DOCUMENTS FOR UNIT PRICE (D0-900F/10048F/1005)
 - GUIDELINES ON EROSION & SEDIMENT CONTROL FOR URBAN SITES, MAY 1987.
8. ENVIRONMENTAL GUIDELINES FOR ACCESS ROADS & WATER CROSSINGS BY O.M.N.R.

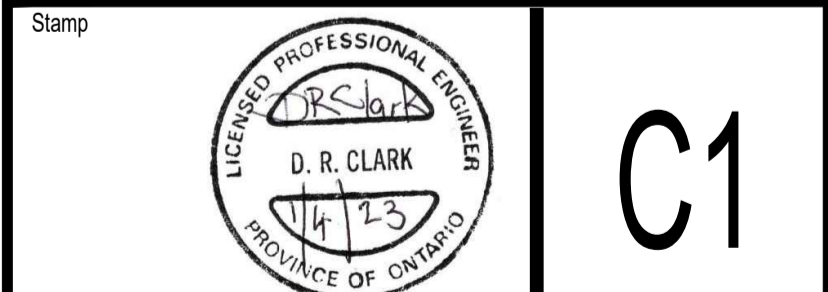

Project
ORLEANS RESIDENTIAL & MEDICAL FACILITY
3996 Innes Road, Ottawa, ON.

Title: SITE SERVICING PLAN GRADING PLAN
Scale: 1:250

Date: 2023/04/01
Revision: 1
Drawing #: SS & GR

Watermain Crossing Table

Watermain Obvert elevation	88.33
Sanitary invert at crossing	88.65
Storm line invert at crossing	88.70
Foundation drain pipe at crossing	88.72

	Purpose	TOG	Up stream Invert	D/N stream Invert	Size	OPSD	MH Cover Standard DWG	Top Cover
CB#1	Storm	90.50	-	90.00	600x600	705.010	S19.1	Open
CBMH#2	Storm	90.80	89.80	89.80	1200mm Dia	701.010	S24.1	Closed
CBMH#3	Storm Monitoring MH	90.80	89.58	89.58	1200mm Dia	701.010	S24.1	Closed
CBMH#4	Sanitary Monitoring MH	90.80	88.05	88.05	1200mm Dia	701.010	S24	Closed
Stormceptor EF04	80% TSSA Removal	90.80	88.02	08.02	1200mm Dia	N/A	S24	Closed

Gas line is 0.6 below grad and has no conflict

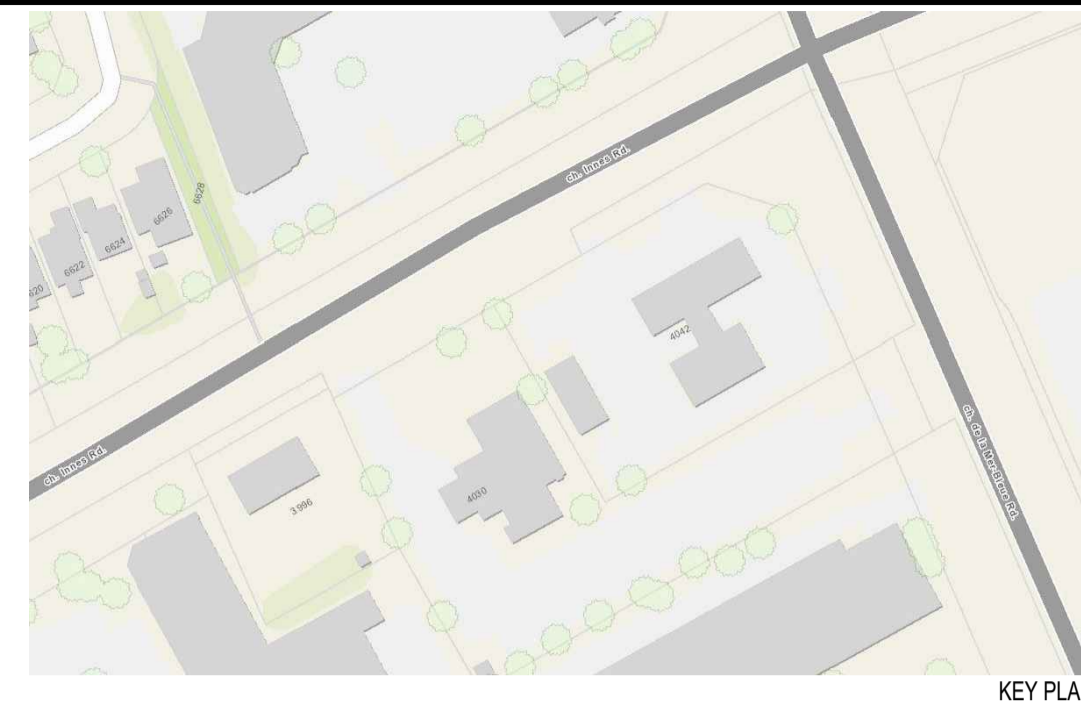

NOTES: EROSION AND SEDIMENT CONTROL
1. CONTRACTOR SHALL IMPLEMENT BEST MANAGEMENT PRACTICES TO PROVIDE FOR THE PROTECTION OF THE AREA DRAINAGE SYSTEM AND THE RECEIVING WATERCOURSE, DURING CONSTRUCTION ACTIVITIES. THE CONTRACTOR ACKNOWLEDGES THAT FAILURE TO IMPLEMENT EROSION AND SEDIMENT CONTROL MEASURES MAY BE SUBJECT TO PENALTIES IMPOSED BY ANY APPLICABLE REGULATORY AGENCY.

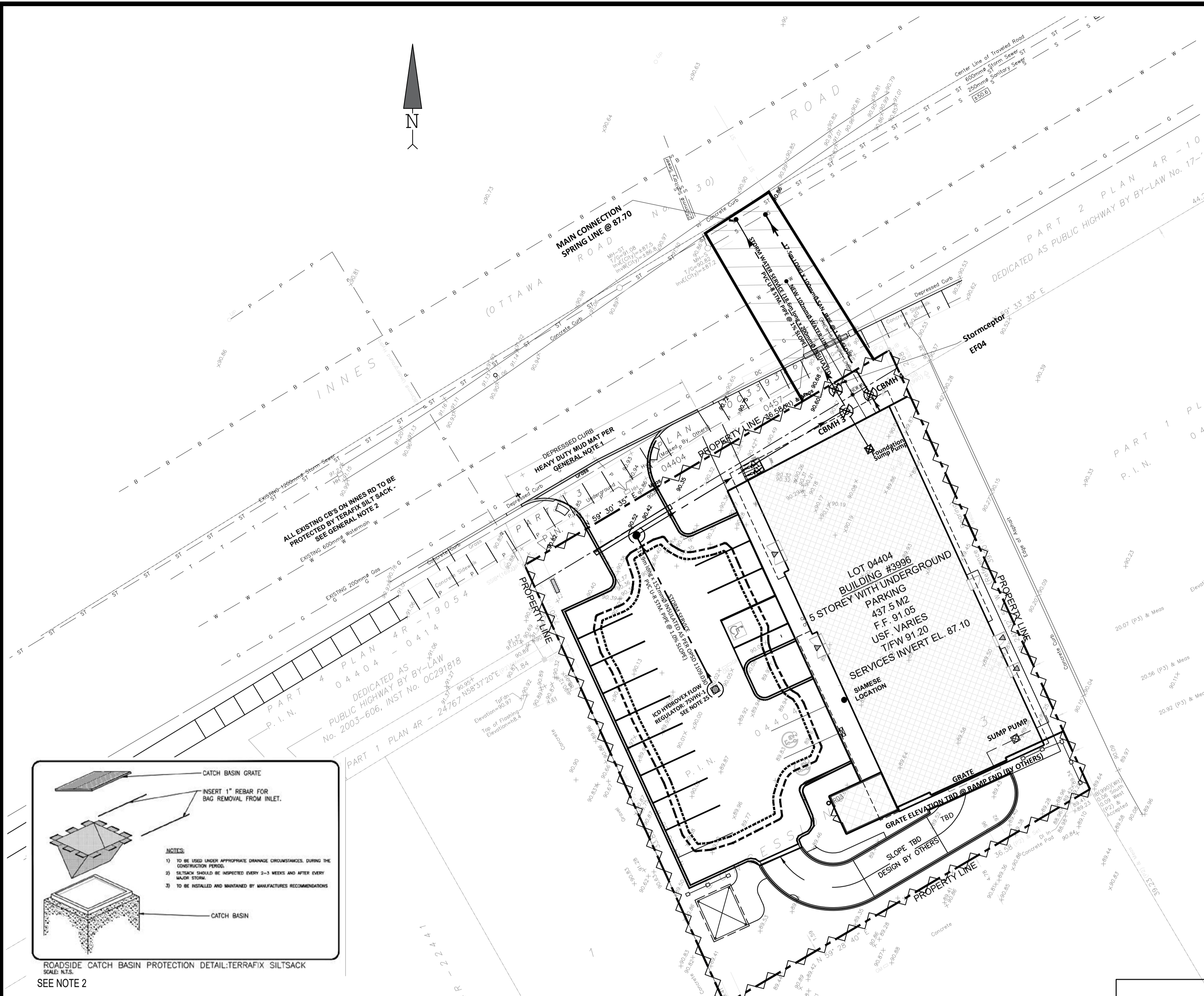

GENERAL NOTES & LEGEND:

- PROPERTY LINE
- ~ ~ ~ SILT FENCE PER OPSD 219.130
- [Symbol] PROPOSED BUILDING ENVELOPE
- [Symbol] EXISTING FIRE HYDRANT
- [Symbol] DC PROPOSED CONCRETE CURB WITH DEPRESSION
- [Symbol] HP EXISTING HYDRO POLE
- [Symbol] EXISTING GROUND ELEVATION
- [Symbol] PROPOSED ELEVATION
- [Symbol] PROPOSED DOOR ENTRANCE
- [Symbol] DIRECTION AND SLOPE OF SURFACE WATER FLOW
- [Symbol] F.F. PROPOSED FINISHED FLOOR ELEVATION
- [Symbol] USF PROPOSED UNDERSIDE OF FOOTING ELEVATION
- [Symbol] BM SITE BENCHMARK SITE BENCHMARK 2 NAILS IN UTILITY POLE ELEVATION=91.06
- [Symbol] TORW PROPOSED TOP OF RETAINING WALL
- [Symbol] BORW PROPOSED BOTTOM OF RETAINING WALL
- 100 YEAR STORM PONDING LIMIT CONTOUR LINE
- 100 YEAR + 20% STORM PONDING LIMIT CONTOUR LINE
- [Symbol] As ASPHALT
- [Symbol] Co CONCRETE
- [Symbol] Gr GRASS
- [Symbol] TREE

1. HEAVY DUTY MUD MAT IS REQUIRED AT SITE ENTRANCE
2. ALL CB TO BE PROTECTED WITH TERAFIX SILT SACK
3. CONCRETE BARRIER CURB PER OPSD 600.110
4. SEWER/STORM LATERAL CONNECTIONS PER OPSD 1006.020
5. THE CONTRACTOR IS REQUIRED TO GET WRITTEN PERMISSION FROM ADJACENT PROPERTY OWNERS FOR WORK OUTSIDE THE PROPERTY LINE
6. HEAVY DUTY SILT FENCE PER OPSD 219.136
7. THE FOLLOWING DOCUMENTS HAVE BEEN REVIEWED - CITY OF OTTAWA STANDARD TENDER DOCUMENTS FOR UNIT PRICE (DO-006F 1004&F1005) - GUIDELINES ON EROSION & SEDIMENT CONTROL FOR URBAN SITES, MAY 1987 - ENVIRONMENTAL GUIDELINES FOR ACCESS ROADS & WATER CROSSINGS BY O.M.N.R.

Stamp
C2

Project
ORLEANS RESIDENTIAL & MEDICAL FACILITY
3996 Innes Road, Ottawa, ON.

Title: EROSION & SEDIMENT CONTROL PLAN	Drawn / A.F. / Verif. / D.K.	Scale: 1:250
Date: 2023/03/30	Revision: 1	Drawing #: ES

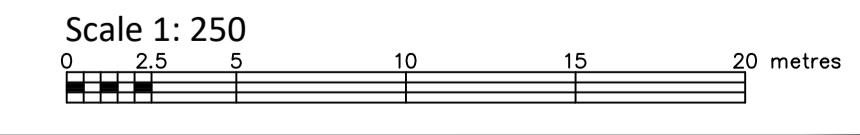
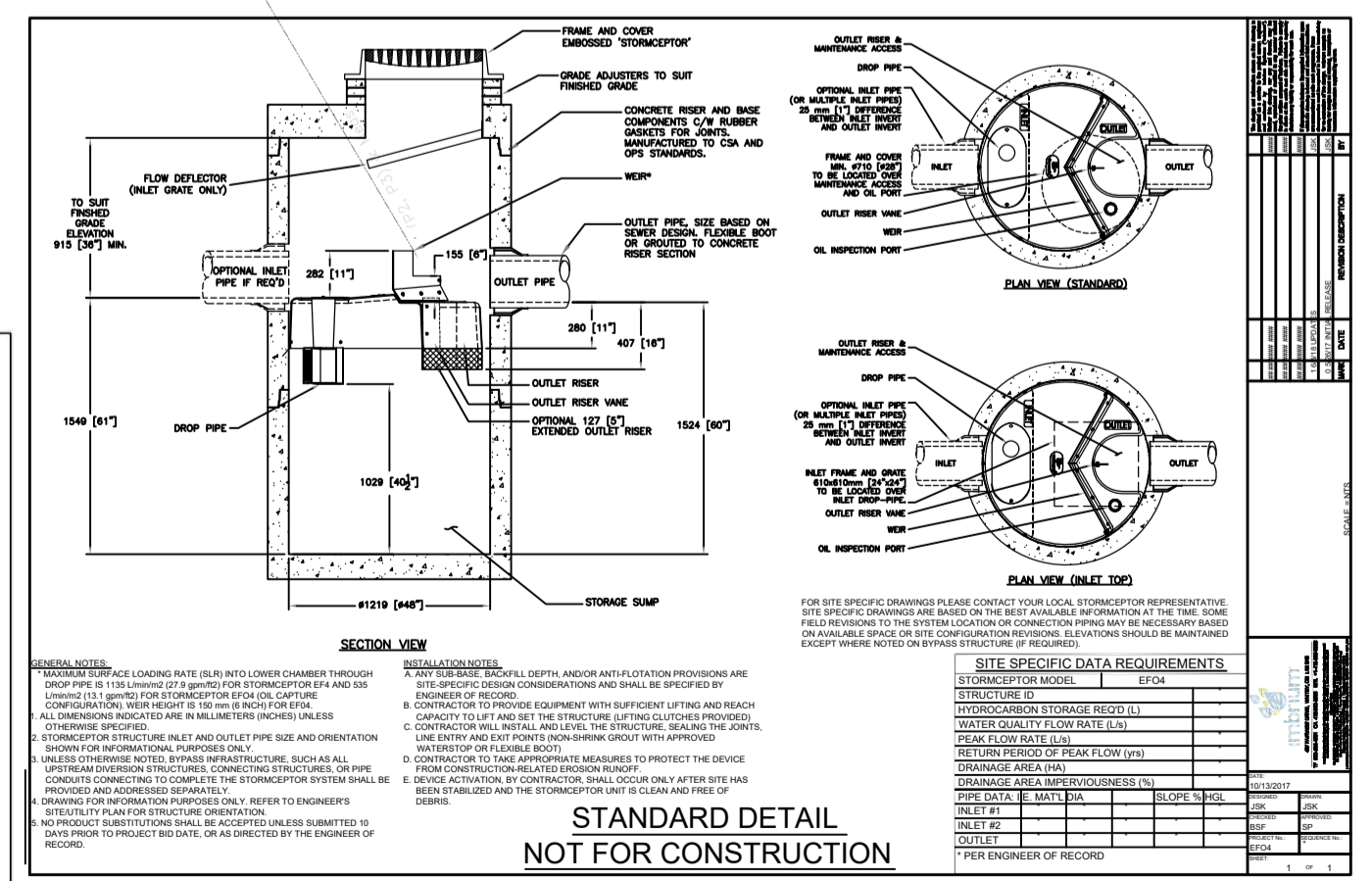
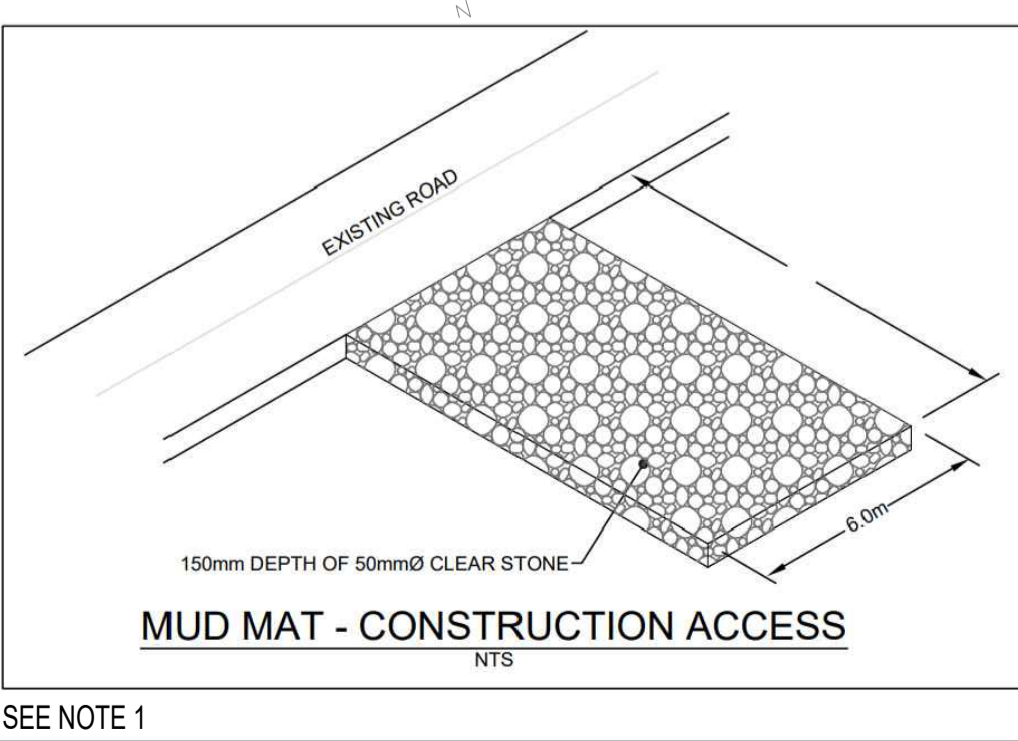
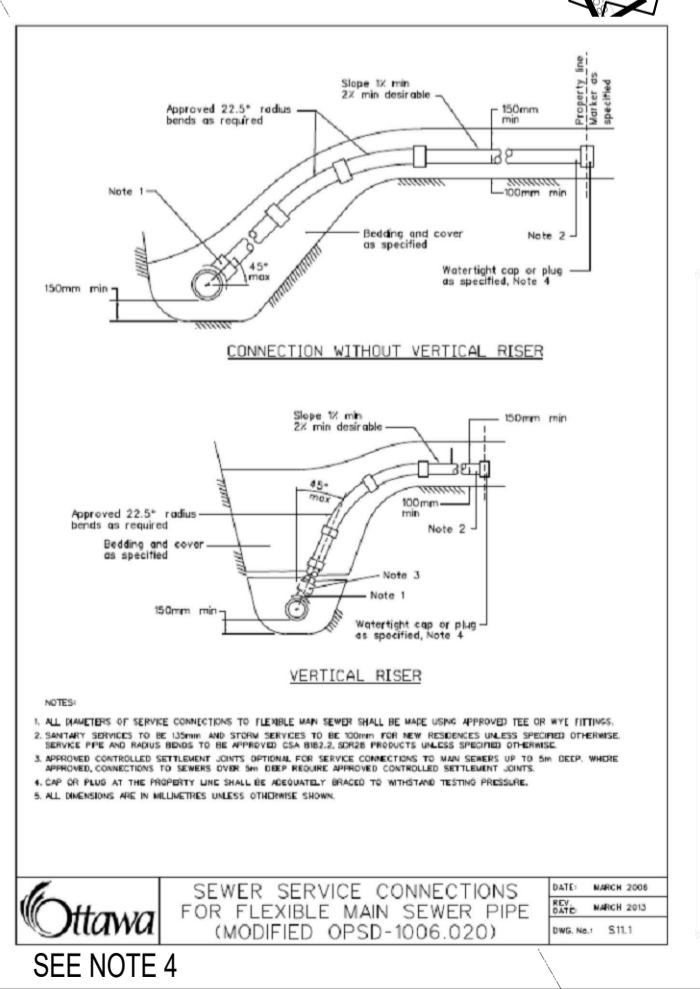
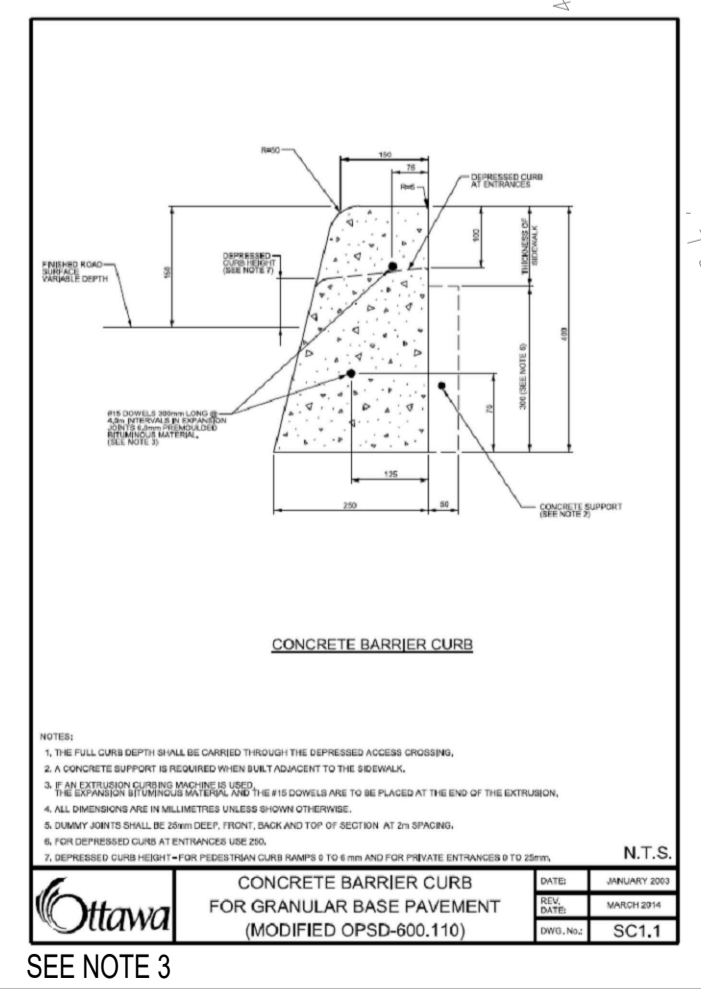
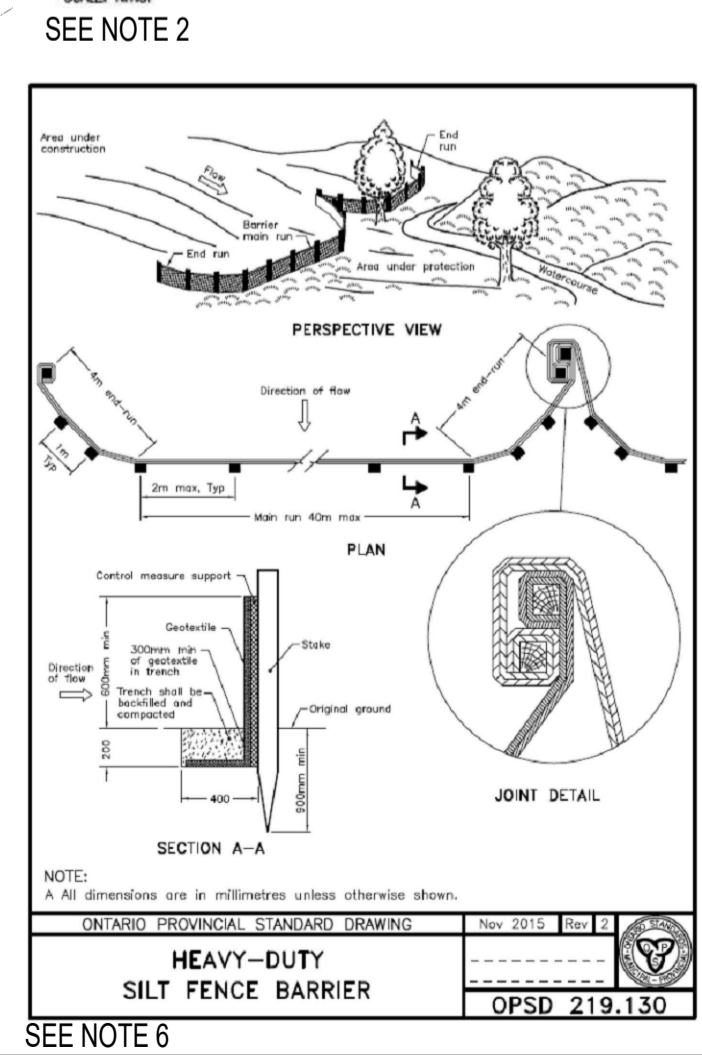
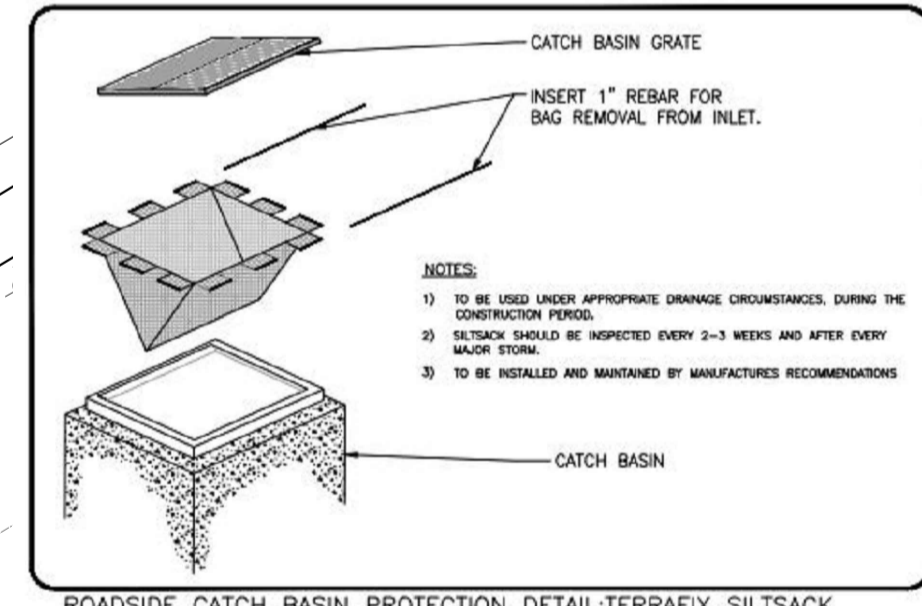

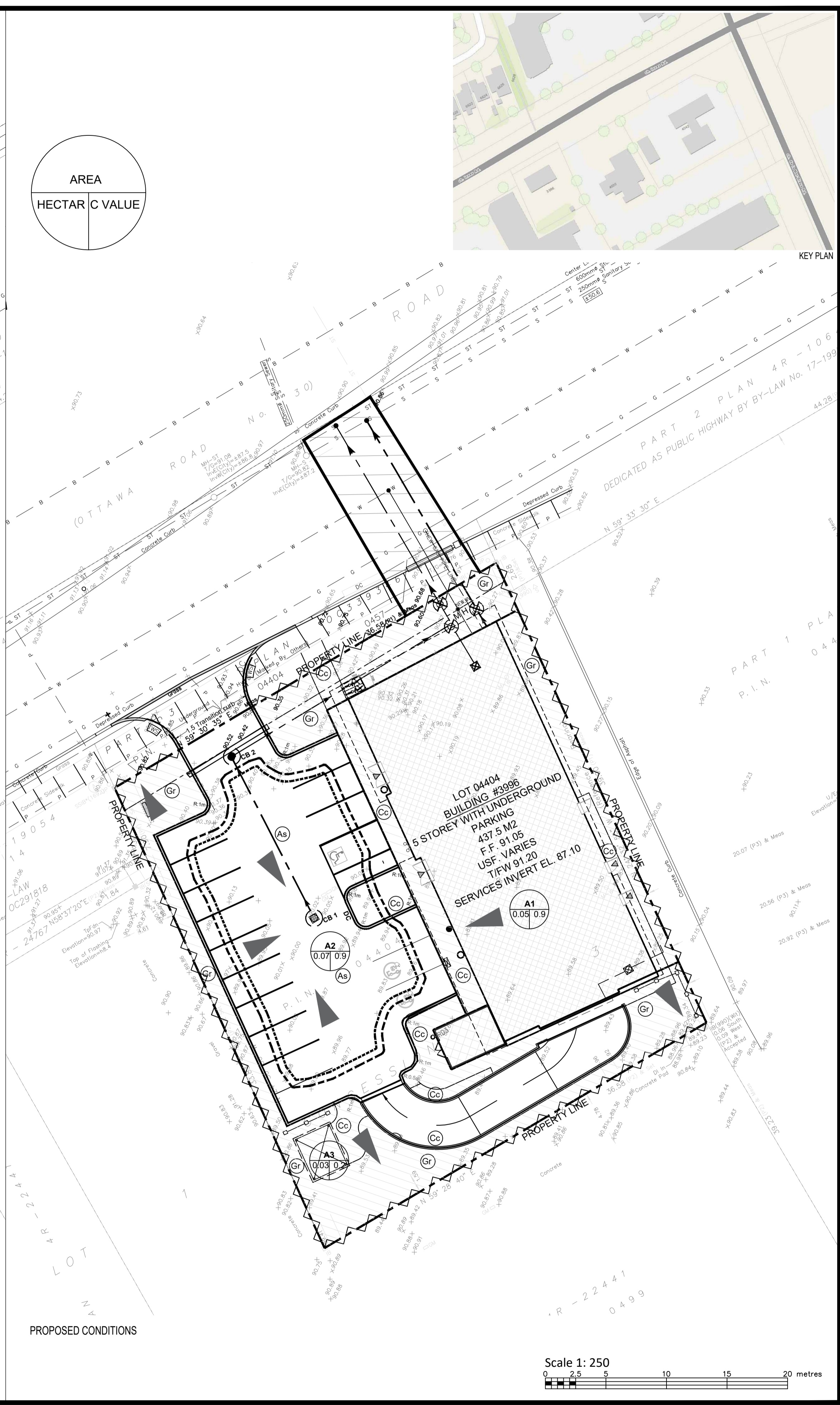

EXISTING CONDITIONS

PROPOSED CONDITIONS

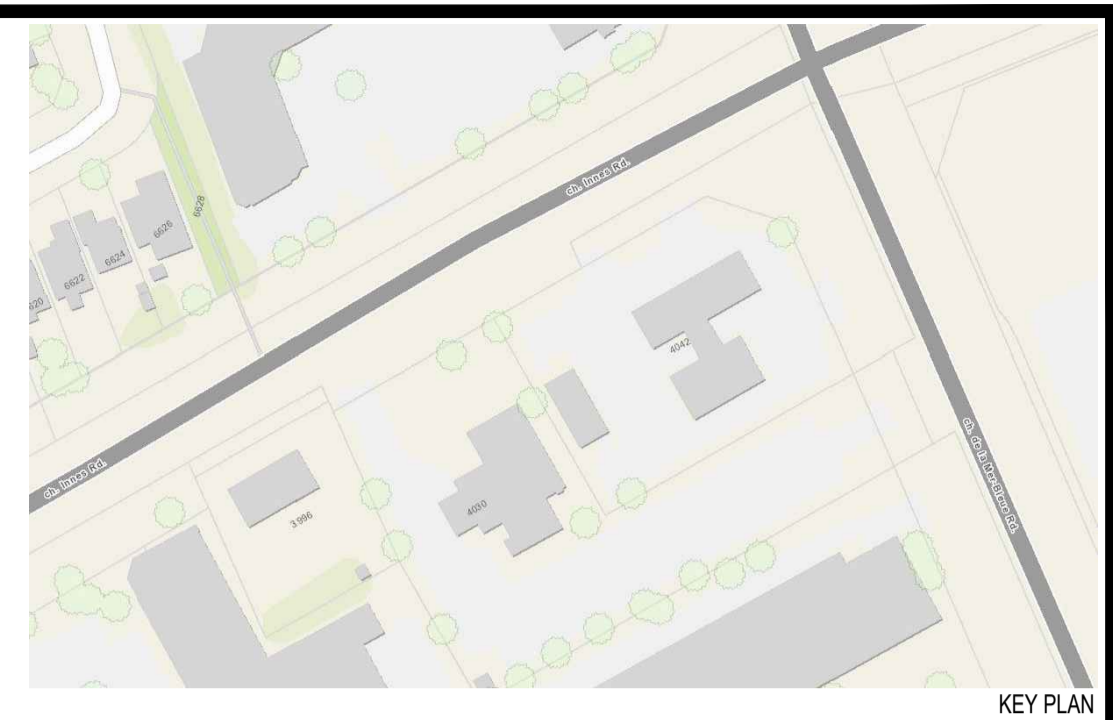

EAU Structural Environmental Services
 Derrick Clark PEng
 EAU Structural & Environmental Svs
 tel., 613 869 0523, derrick.r.clark@rogers.com

Consultants
PTabet architecte
 2232 rue Saint-Louis,
 Gatineau QC J8T 5L6
 t.: 819.568.3994
 c.: 613.797.9375
 pierretabearchitecte.com

No	DATE	ISSUED FOR	App.
1	2022/09/14	SITE PLAN CONTROL	D.K.
2	2022/12/31	PER CITY REVIEW	D.R.C
3	2023/03/30	PER CITY REVIEW	D.R.C
4			
5			

GENERAL NOTES & LEGEND:

- PROPERTY LINE
- ~~~~~ SILT FENCE PER OPSD 219.130
- [Hatched Box] PROPOSED BUILDING ENVELOPE
- [Symbol] EXISTING FIRE HYDRANT
- [DC] PROPOSED CONCRETE CURB WITH DEPRESSION
- [HP] EXISTING HYDRO POLE
- [Symbol] EXISTING GROUND ELEVATION
- [Symbol] PROPOSED ELEVATION
- [Symbol] PROPOSED DOOR ENTRANCE
- [Symbol] DIRECTION AND SLOPE OF SURFACE WATER FLOW
- [Symbol] PROPOSED FINISHED FLOOR ELEVATION
- [Symbol] PROPOSED UNDERSIDE OF FOOTING ELEVATION
- [BM] SITE BENCHMARK SITE BENCHMARK 2 NAILS IN UTILITY POLE ELEVATION=91.06
- [TORW] PROPOSED TOP OF RETAINING WALL
- [BORW] PROPOSED BOTTOM OF RETAINING WALL
- 100 YEAR STORM PONDING LIMIT CONTOUR LINE
- 100 YEAR + 20% STORM PONDING LIMIT CONTOUR LINE
- [As] ASPHALT
- [Cc] CONCRETE
- [Gr] GRASS

1. HEAVY DUTY MUD MAT IS REQUIRED AT SITE ENTRANCE
2. ALL CB TO BE PROTECTED WITH TERAFOX SILT SACK
3. CONCRETE BARRIER CURB PER OPSD 600.110
4. SEWER/STORM LATERAL CONNECTIONS PER OPSD 1006.020
5. THE CONTRACTOR IS REQUIRED TO GET WRITTEN PERMISSION FROM ADJACENT PROPERTY OWNERS FOR WORK OUTSIDE THE PROPERTY LINE.
6. HEAVY DUTY SILT FENCE PER OPSD 219.136
7. THE FOLLOWING DOCUMENTS HAVE BEEN REVIEWED
 - CITY OF OTTAWA STANDARD TENDER DOCUMENTS FOR UNIT PRICE (DO-006F 1004&F1005)
 - GUIDELINES ON EROSION & SEDIMENT CONTROL FOR URBAN SITES, MAY 1987.
8. ENVIRONMENTAL GUIDELINES FOR ACCESS ROADS & WATER CROSSINGS BY O.M.N.R.

Stamp

C3

Project
ORLEANS RESIDENTIAL & MEDICAL FACILITY
 3996 Innes Road, Ottawa, ON.

Title: DRAINAGE PLAN	Drawn / A.F.	Scale: 1:250
Date: 2023/03/30	Verif. / D.K.	Drawing # D
Revision: 0		

CITY PLAN #18675 FILE #D07-12-4-0209