

HILLSIDE COMMONS - 20030

ARCHITECTURAL DESIGN BRIEF IN SUPPORT OF  
SITE PLAN CONTROL APPLICATION

09 MAY 2022



## TABLE OF CONTENTS

PROJECT INFORMATION	3
OTTAWA CITY DOCUMENTS	4
OTTAWA ZONING & MAJOR HUBS	7
SITE CONTEXT	8
MASSING & CONTEXT	11
BUILDING TRANSITION & GRADING	15
PUBLIC REALM	16
BUILDING DESIGN	17
URBAN LANDSCAPE	18
SUSTAINABILITY	21
SOLAR ANALYSIS	22
PROPOSED SITE PLAN	24
PROPOSED SITE SERVICING	25
TYPICAL FLOOR PLANS	26
ELEVATIONS	39
SCHEMATIC SECTIONS	44

## PROJECT INFORMATION

### Application Submission

This Design Brief has been prepared by Rossmann Architecture Inc. for Hillside Commons Inc (the owner) in support of the application for Site Plan Control for the development of the property located at 3277 St. Joseph Boulevard in Orléans, Ottawa (K1C 1T1), where St. Joseph intersects Tenth-Line Road near Highway 174 in the East of the City. This property will be referred herein as the 'Subject Site'.

The Subject Site is within the R5Z zone, allowing a building height of up to 105m A.S.L. for the portion of the site within the [1415] exception and an 85.8m A.S.L. height restriction for the northern 'leg' [1363] exception (to a maximum of ten storeys). It should be noted that there is a 10m city sewer easement running parallel to Tenth-Line Road through the middle of the site, where construction is limited to landscaping and retaining walls per city requirements.

The proposed development (*Figure 1.*) consists of two (2) mid-rise apartment towers of nine (9) storeys along with a five (5) storey component which respects the height restriction of the [1363] exception zone, totalling two hundred and seventy four (274) rental dwellings ranging from studios to three (3) bedroom units. Additionally, one hundred and eighty four (184) vehicle parking spaces have been provided over 3 levels of garage and servicing below grade of each tower, linked by a driveway, at grade, between the two buildings across the sanitary easement. The eastern tower shall be referred to herein as 'Building A' and the western tower as 'Building B'. Bicycle storage on the first levels of parking in building B, accessible directly from the easement or through the garage levels, totalling one hundred and thirty seven (137) bays have also been provided.

The project intends to maximise the potential of the subject site, while overcoming the challenges of significant grade difference, traffic impact and the city sanitary easement running through the property.

This prominent intersection provides a valuable opportunity to improve the urban landscape of Orléans through a landmark project, positively contributing to the architectural world.

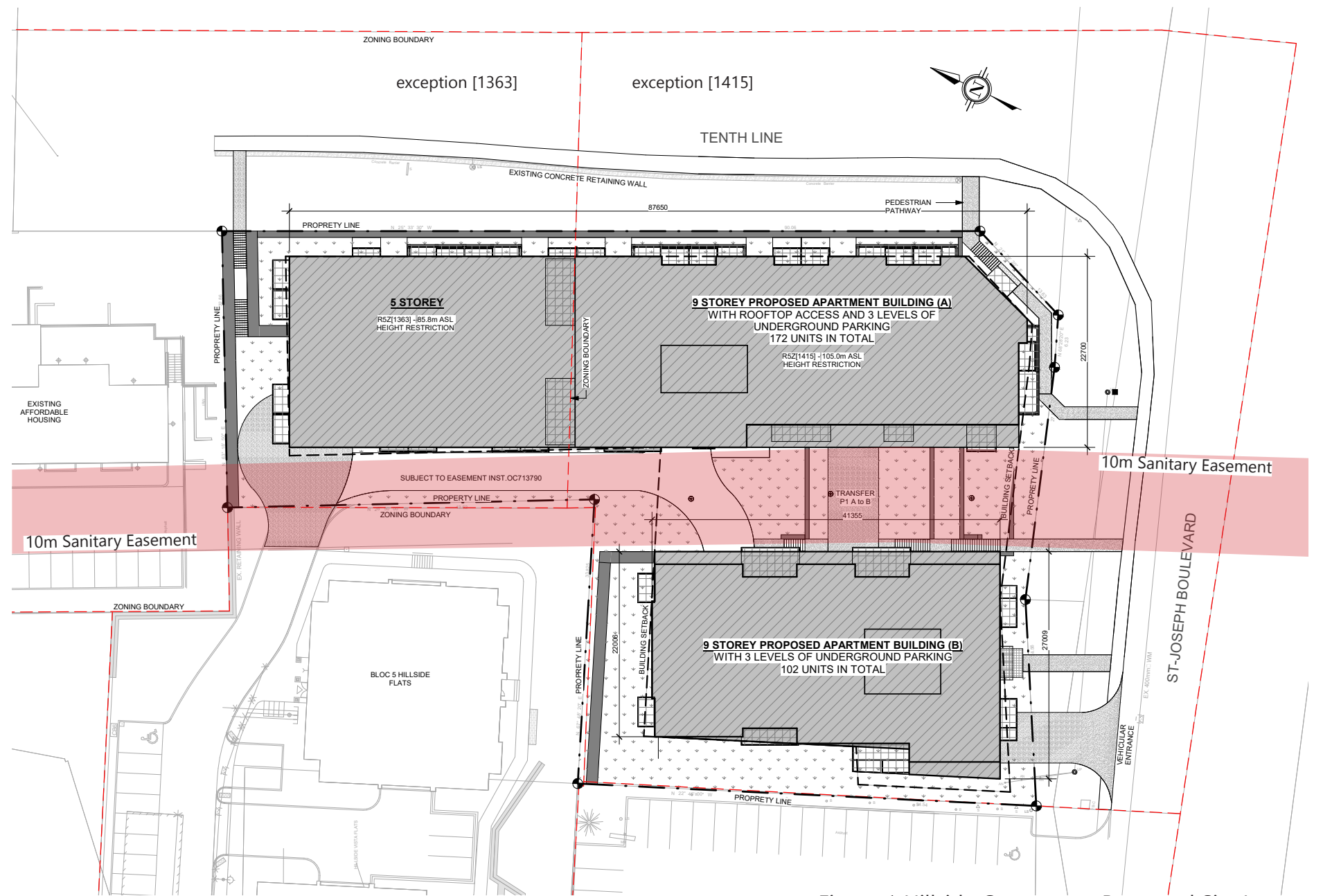

Figure 1. Hillside Commons - Proposed Site Layout



CITY DOCUMENTS

Ottawa Official Plan (OP):

The Subject Site has been identified as being within or along the following (per the relevant existing Ottawa Official Plan):

- Schedule A: An 'Urban Area';
- Schedule B: A 'Mixed Use Centre' (Figure 2.);
- Schedule C: All three primary cycling networks, namely 'Spine Route', 'Multi-use Pathway' and 'Cross-Town Bikeway';
- Schedule D: Proximity to an existing LRT-Light Rail Transit Station and running along a 'Transit Priority Corridor';
- Schedule E: An existing 'Arterial' corridor;
- Schedule I: A 'Scenic Entry Route'.

Recent Ottawa Official Plan:

Additionally, the Subject Site has been identified as being within or along the following (per the recently adopted Ottawa Official Plan):

- Annex 2: A 'Development Zone of Influence';
- Annex 6: 'Outer East Line 1 and 3 Stations' (in progress);
- Annex 8B: 'Taylor Creek';
- Schedule B8: 'Evolving Neighbourhood' within a Town Centre 'hub' along a 'Mainstreet' and 'Minor Corridor' near future O-Train Station (Figure 3.);
- Schedule C1: 'Protected Major Transit Station Areas (PMTSA)' (Figure 4.);
- Schedule C2: 'Transit Priority Corridor' near O-Train Station;
- Schedule C4: 'Existing Arterial';
- Schedule C7-A: Mainstreet corridor within a 'Design Priority Area' (Figure 5.);

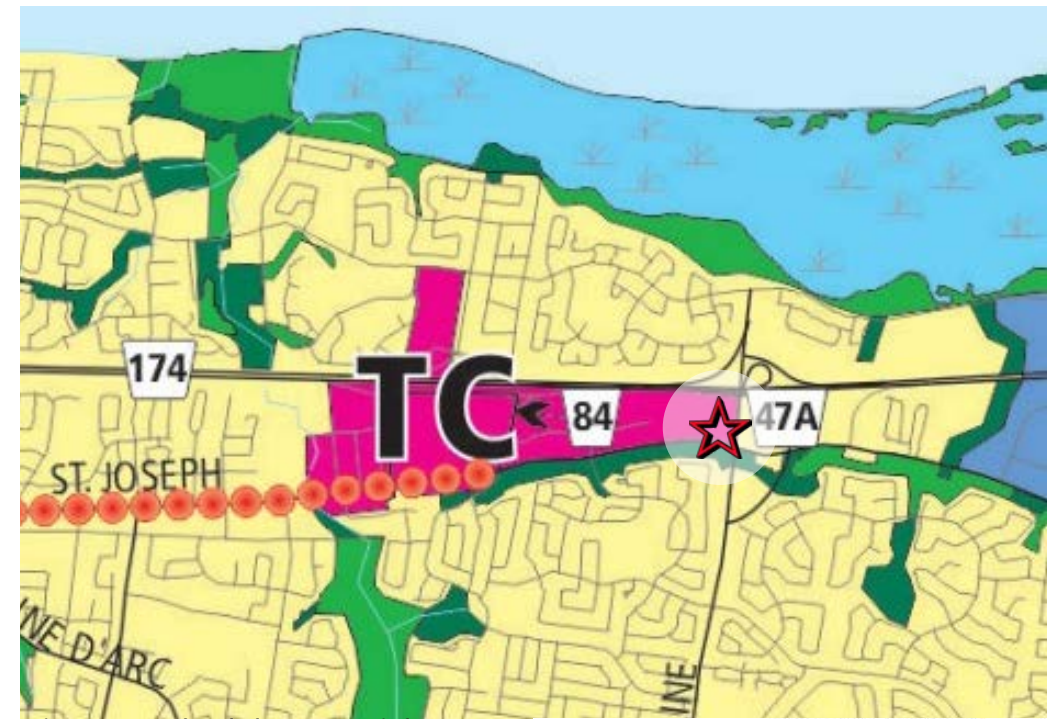

Figure 2. Schedule B (Partial)  
Ottawa Official Plan



Figure 3. Schedule B8 (Partial) - Suburban (East) Transect

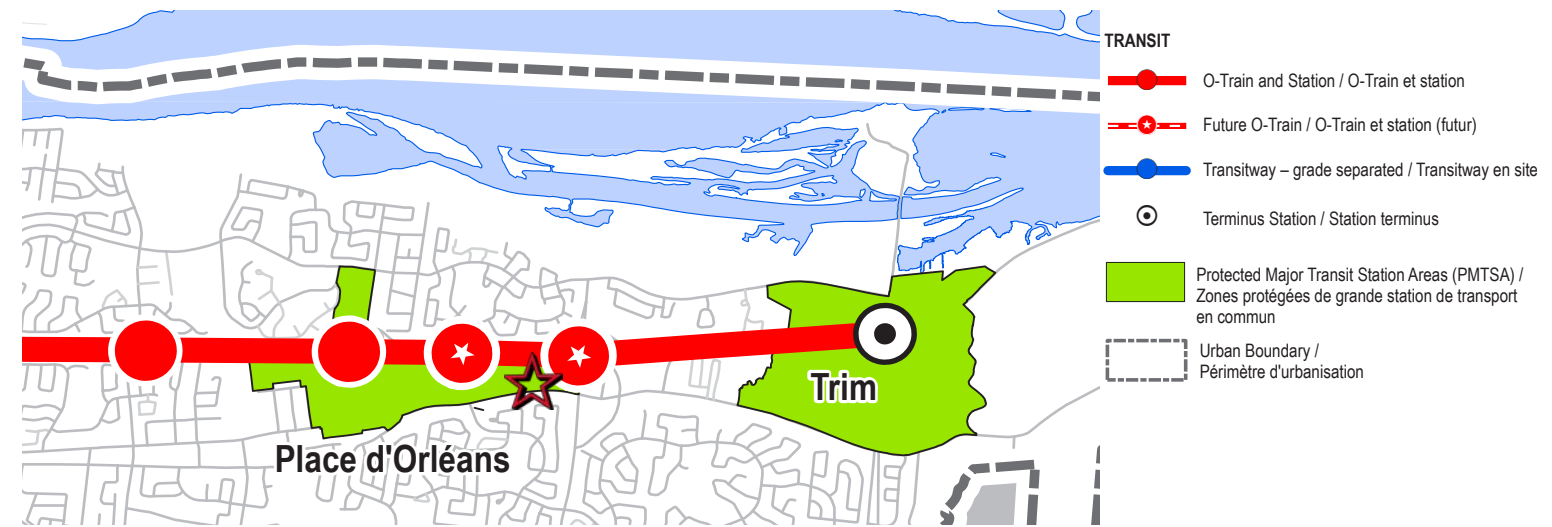

Figure 4. Schedule C1 (Partial)  
Protected Major Transit Station Areas



## Secondary Plan for the Town Centre (Former City of Cumberland)

The 'Site Specific Policy' of the Former City of Cumberland (OP 4.11.5) encourages "the creation of a dynamic, multiple use town centre . . . which will foster a "sense of place" for the residents of the City" through various development concepts including the provision of "medium and high density residential development . . . to increase population density within the centre" while providing a policy framework which ensures that "all future development exhibits a high standard of urban design".

The Subject Site has been designated as being within an 'Urban Residential' zone with a special residential height exception (*Figure 6.*) which holds a major objective of the policy (4.11.2.5) to "encourage planned residential developments", "permit . . . medium and high density residential development" while respecting the maximum heights prescribed. Additionally, private underground parking facilities are encouraged to "increase density" while not being the major focus in the site (4.11.3.3). Servicing policies require that, where possible, underground installations be provided to limit the "visual clutter and protect the urban form and streetscape" (4.11.4.2).

A major objective of the Town Centre Secondary Plan is to ensure, as mentioned, that all future development "exhibits a high standard of urban design" which will in turn improve the streetscape and encourage "attractive, innovative and diverse" development, improving the City's visual image.

As part of the Urban Design Policies, the city has undertaken to generate a unique character for the Town Centre by implementing, among other items, various strategies of pedestrian animation through connections and walkway treatments (4.11.5.2).

### Document Summary

Most notably, the Subject Site has been identified as a Mixed Use Centre along an Arterial Mainstreet, which supports high density residential developments (By-Law 2015-293). Additionally, it is located in "Area Z: Near Major LRT Stations" per 'Schedule 1A' (By-Law 2008-250) which encourages densification and permits an allocation of zero (0) parking for residents.

The "Orléans Corridor Secondary Plan Study" (*Figure 7.*), along with Schedule D in the Official Plan as well as "The Outer East Line 1 and 3 Stations Secondary Plan" (study in progress) identifies the junction of Tenth-Line Road and Highway 174 as the site for a future LRT Station, with Tenth-Line Road being a "Transit Priority Corridor". The study aims to evaluate policies and zoning to improve opportunities for intensification, infill development, housing affordability and employment. Community members will be able to utilise the new nearby O-train stations, greenspaces and existing and future local amenities, all while benefiting from the gradual evolution of the historic core of Orléans.

Similarly, a Community Design Plan (*Figure 8.*), carried out in 2003, provides guidelines for the decisions made with regard to land-use and future priorities. It is the "Council approved guide to the long-term growth and development of the St. Joseph Boulevard Corridor". It identified St. Joseph Boulevard as a major arterial road in the City of Ottawa's East End and as the perfect location for revitalisation and intensification, providing continuous access across the city. As part of the study and subsequent strategies, amendments were made to the Official Plan and Zoning By-Laws with the intention of planning framework simplification that recognised "both the importance of urban



Figure 5. Schedule C7-A (Partial)  
Ottawa Official Plan (New)

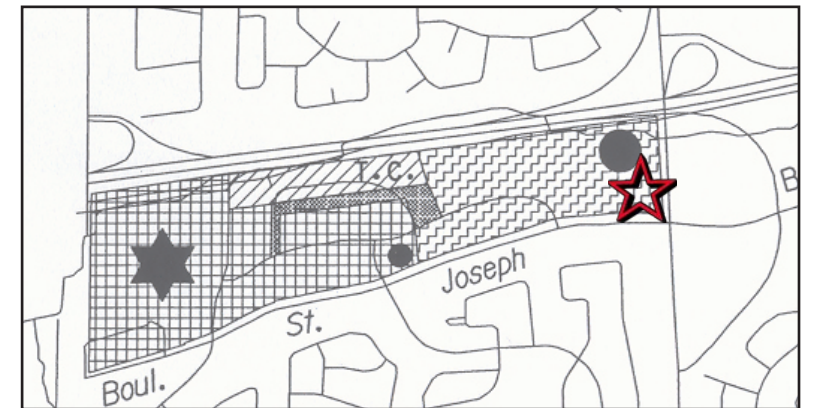
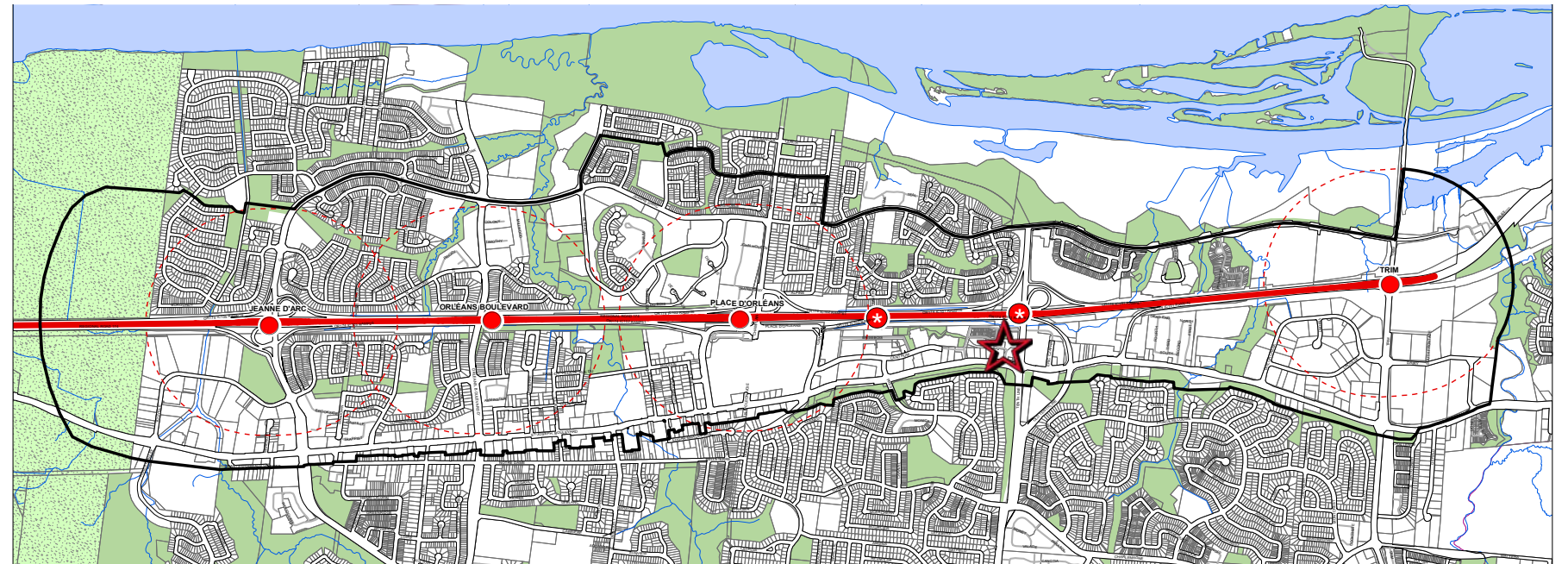

Figure 6. Schedule A-1 (Partial)  
Orleans Town Centre (Former city of Cumberland)



PLANNING STUDY / ÉTUDE DE PLANIFICATION DE  
**Orléans Corridor / Le couloir d'Orléans**

- Study Boundary / Limite d'étude
- LRT / TLR
- + LRT Station - Future / TLR station - futur
- 600m Buffer of Future Light Rail Transit Station / Tampon de 600 de station de train léger sur rail
- Park / Parc
- Greenbelt / Cinture de verdure

Figure 7. Orléans Corridor Secondary Plan Study



corridors in the City of Ottawa and the tremendous redevelopment and intensification opportunities that these corridors provide to the long-term development of the city". The recommendations included maximising the ground floor footprint by building as close as possible to the right-of-way, while accentuating gateways and intersections.

### Response to City Documents

The proposed development has been designed in alignment with provincial, city and community studies, guidelines and provisions. Particularly the 2020 Provincial Policy Statement (Refer to Planning Rationale by *Novatech*), the City of Ottawa Official Plan (existing and recently adopted), and the Town Centre Secondary Plan (Former city of Cumberland).

It seeks to maximise the density potential of the site and surrounding areas while respecting all applicable by-laws and zoning considerations. The proposed footprint respects all setbacks while being set as close as possible to the right-of-way, as well as avoiding the sanitary easement with minimal permanent interference per city requirements. The nine (9) storey towers accentuate the intersection of Tenth-Line Road and St. Joseph Boulevard as recommended by both the community study and city urban policies (4.11), presenting an architectural landmark to the junction, while linking the arterial corridors and cycling network to the quieter private lane at the northwest end of the site which in turn links to Eric Czapnik Way.

Additionally, despite not technically being a high-rise building, the 'Urban Design Guidelines for High-rise Buildings' by the City of Ottawa were considered during the design phases to maximise the benefit to residents in the area while still attaining the investment feasibility of the project.

Furthermore, all abutting properties to the west, northwest and north permit a building height of 85.8m A.S.L. The highest portion of the existing site is currently 75.05m A.S.L. meaning all adjacent properties are permitted to build at least 10.75m above the Subject Site.

Importantly, there are no zoning amendments being sought for this development as the project conforms to all applicable Zoning and By-Laws.

### Context Plan & Analysis

Located along arterial corridors, namely St. Joseph Boulevard and Tenth-Line Road, the Subject Site is easily accessible from Highway 174, which in turn links it to the rest of the City of Ottawa. The Subject Site is within 1.7km of the existing Place D'Orléans Commercial centre and LRT Station and additionally within a few hundred metres of a proposed LRT station on the Highway 174 and Tenth-Line Road junction. It has several bus nodes along the street fronts which link it to the nearby major transport hubs. The site also borders all three primary cycling networks, namely 'Spine Route', 'Multi-use Pathway' and 'Cross-Town Bikeway' which in turn link it to areas nearby designated as current or future public parks for both pedestrians and cyclists.

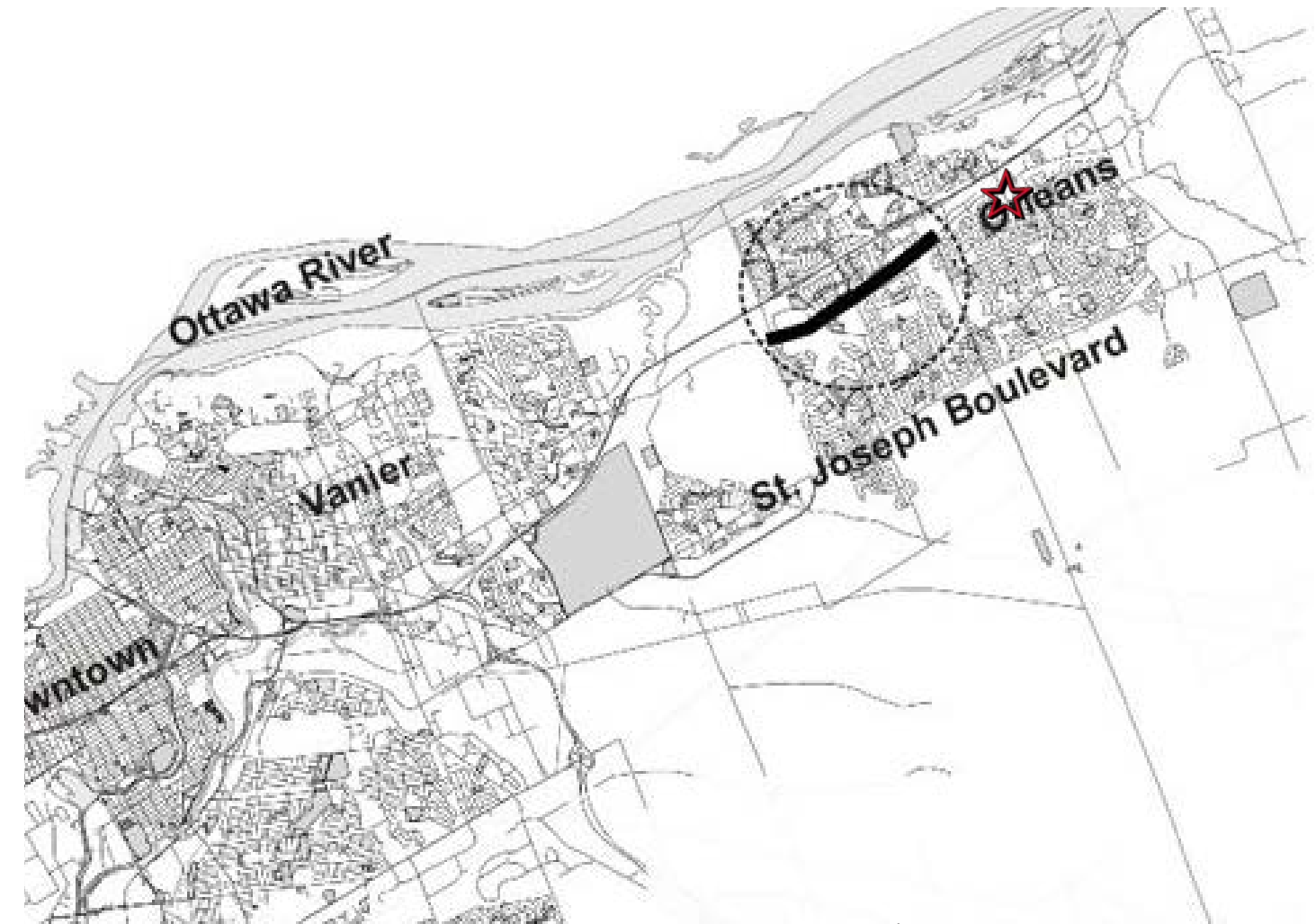
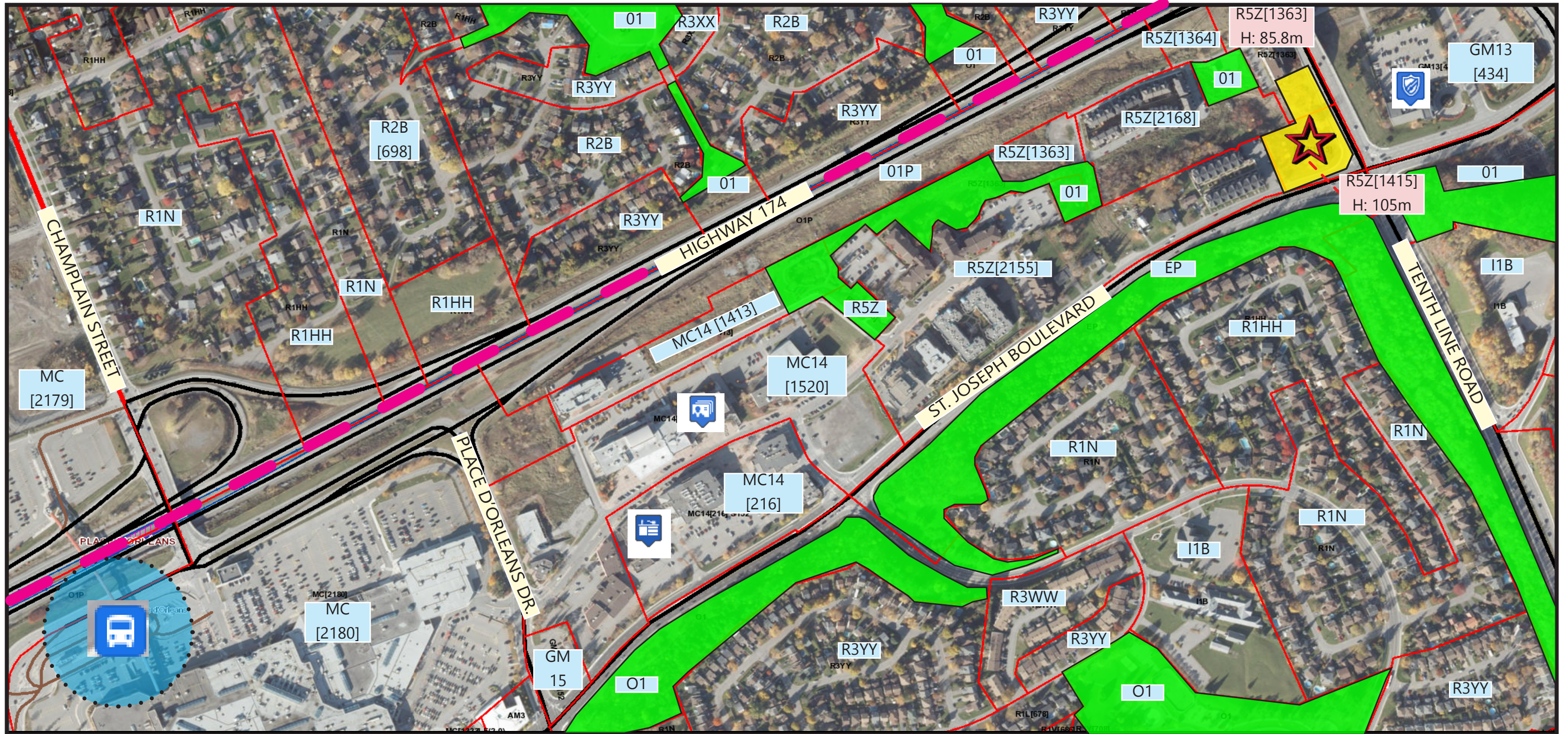

Figure 8. St. Joseph Boulevard Corridor Study





-  Ottawa Police East Division Station
-  Orléans Client Service Centre
-  Orléans-Cumberland Community Resource
-  Place d'Orléans Station - OC Transport hub
-  Main Road
-  Autoroute/Highway
-  Major Transport Hub
-  Current/Future Parks
-  Subject Site



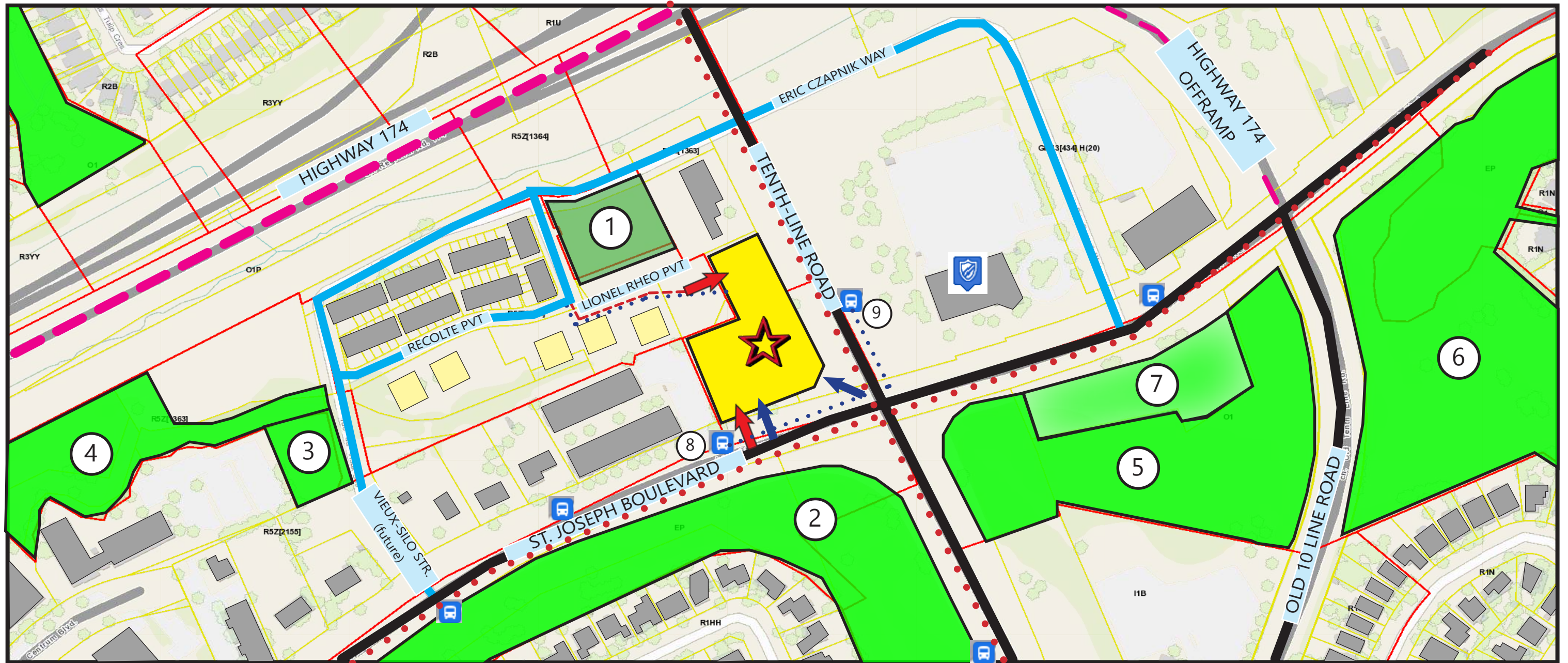

- Ottawa Police East Division Station
- Bus Nodes
- Current Parks
- Future Parks
- Existing Buildings
- Planned Buildings

- Autoroute/Highway
- Main Roads
- Secondary Roads
- Pedestrian Access Routes
- Urban Cycling Network

1. HILLSIDE VISTA PARK
2. RECREATIONAL TRAIL
3. VINETTE SILO PARK
4. CENTRUM PATHWAY
5. PARKLAND
6. ST. JOSEPH BOULEVARD WOODS
7. ORLEANS COMMUNITY GARDEN
8. BUS LINES: 33,302
9. BUS LINES: 33,233,235,236

- Subject Site
- Vehicular Access & Secondary Pedestrian Access
- Primary Pedestrian Access

100m





**C - VIEW FROM TENTH LINE ROAD**



**D - VIEW FROM INTEWRSECTION**

**B - VIEW FROM ERIC CZAPNIK WAY**



**A - VIEW FROM ST JOSEPH BOULEVARD**

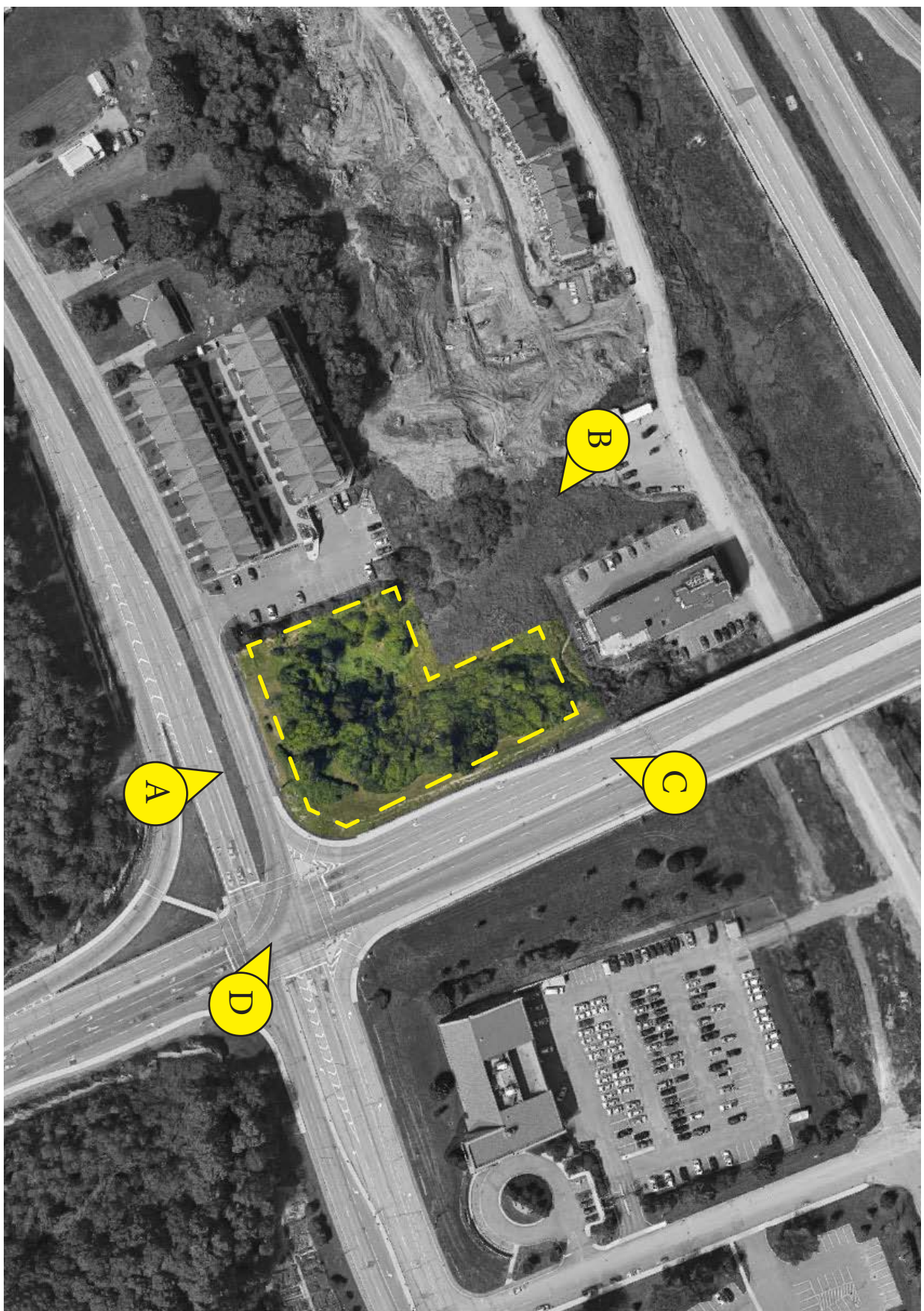





**C - VIEW FROM TENTH LINE ROAD**



**D - VIEW FROM INTEWRSECTION**

**B - VIEW FROM HIGHWAY 174**



**A - VIEW FROM ST JOSEPH BOULEVARD**

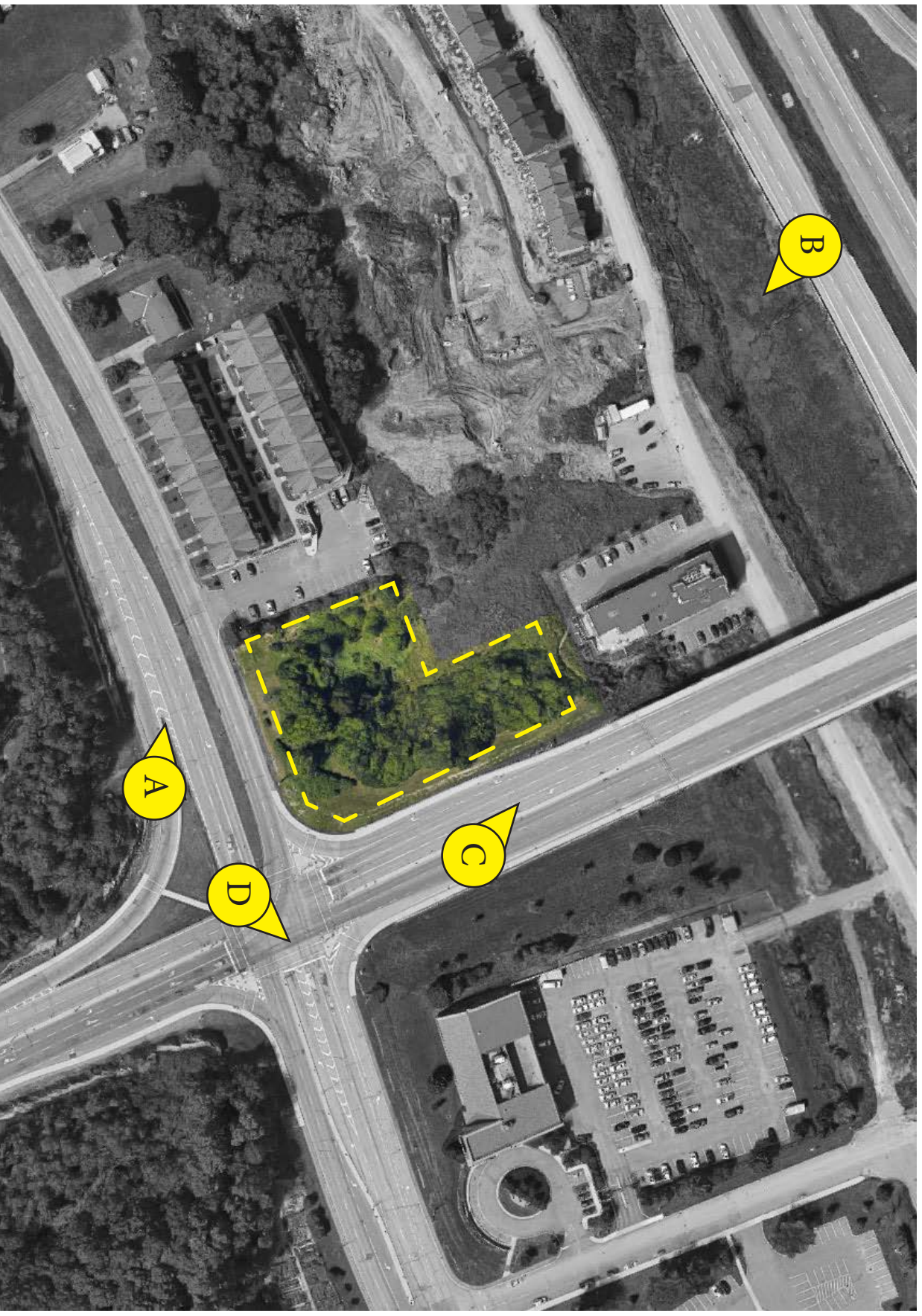



# MASSING

The proposed development builds up to the height of nine (9) storeys through a trinity of building mass, aimed at complementing the context in which it is planned as set out in Section 4.11 of the Official Plan, with particular attention to policies 22-24 for 'Design Priority Areas'. These portions were initially explored through conceptual massing and gradually evolved through city interaction and design progression as seen on page 12 through to the current proposal, expressing form and massing through architectural articulation as seen on page 13. Namely:

**Base:** The base or podium is positioned parallel to the streets and expressed through a combination of a heavier limestone or architectural block material as well as a series of partially enclosed porches which are projected from the building footprint, significantly present where adjacent to the public realm of St. Joseph Boulevard and Tenth-Line Road. Given that both buildings along St. Joseph Boulevard are nine storeys in height, this 1.4m 3-storey projection brings the footprint closer to the street allowing for a more relatable human scale transition and relationship between the built form of the street and the pedestrian realm with wide walkways where possible. Similarly, the material and colour helps define the base with its own distinct, large format, masonry cladding, anchoring the building to the site and enriching the quality of the street realm while accentuating the arterial corridors of St. Joseph Boulevard and Tenth-Line Road. This stone cladding also extends to the 4th storey and 7th storey in limited areas across the length of the building along Tenth-Line in order to vertically articulate the higher portions of the building while breaking the cladding in recessed areas to reduce the overwhelming sense of its horizontal dominance and overall weight along Tenth-Line Road. (Figure 9.)

**Middle:** The middle section is setback 2.7m from the footprint in areas, specifically between the two towers, and is used to horizontally break the base from the top, while 'spilling' up to the 9th storey and down to the 2nd storey in areas with recessed balconies. The northern portion of building 'A' steps additionally to create a distinct 3 storey 2 storey relationship to better facilitate transition to the five storey building lower down to the north. This section is highlighted using a dark aluminum panel cladding systems which allows it to stand out even more. This also marks the 'end' of the five (5) storey Northern 'leg' of Building A which terminates with a rooftop terrace for the residents to enjoy while minimising the impact to the surrounding area through the use of transparent sound screens, indirect lighting techniques and landscaping strategies as outlined in 4.11(19) of the Official Plan. (Figure 10.)

**Top:** The top portion of the project, while articulated with rooflines following from the roof terrace portions, aligns with most of the planes from the middle section but is highlighted using a much lighter cladding material in order to soften the sense of weight created by the height of the buildings. This element also descends to the first storey in some areas, tying the building together vertically as well as horizontally. (Figures 10 & 11.)

Notably, the project embraces the sanitary easement which separates the towers through corner window wrapping as seen from St. Joseph Boulevard (where the entrances are situated) and by creating a series of setbacks on the inner facing building facades, increasing the distance between the towers the higher up you are, especially in the living spaces of the units through recessed areas. This helps in creating intimate, private units for the residents. The proposed development has been analysed in its context through various transitional studies and contextual placement of the form as seen on pages 14 and 15.

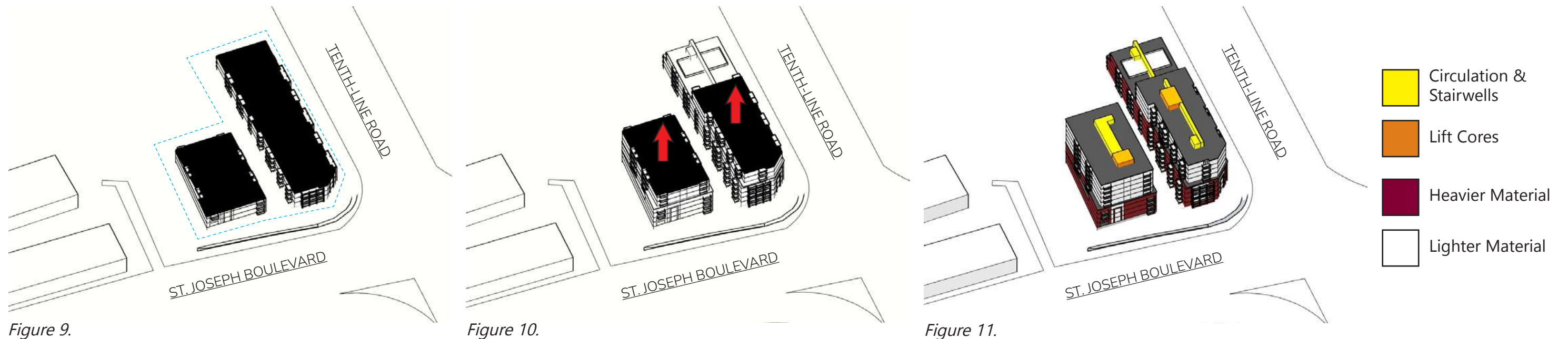

Figure 9. **BASE BUILDING**  
Base form of the building and underground parking.

Figure 10. **UPPER VOLUME**  
Recessed upper 'mid-rise' component of the proposed buildings.

Figure 11. **SURFACE COATING DIAGRAM & CIRCULATION**  
Heavier materials proposed at base, progressively lighter with increased height.



INITIAL EXPLORATIONS

Prior to clarification on height restrictions

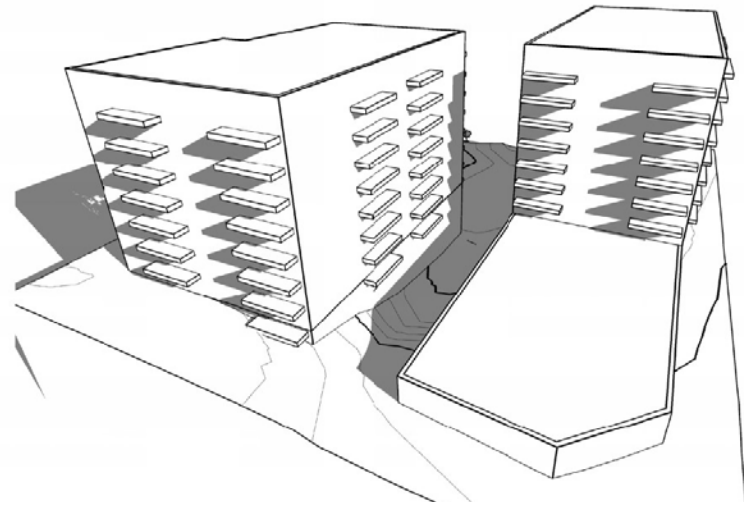

1 - AERIAL VIEW FROM INTERSECTION

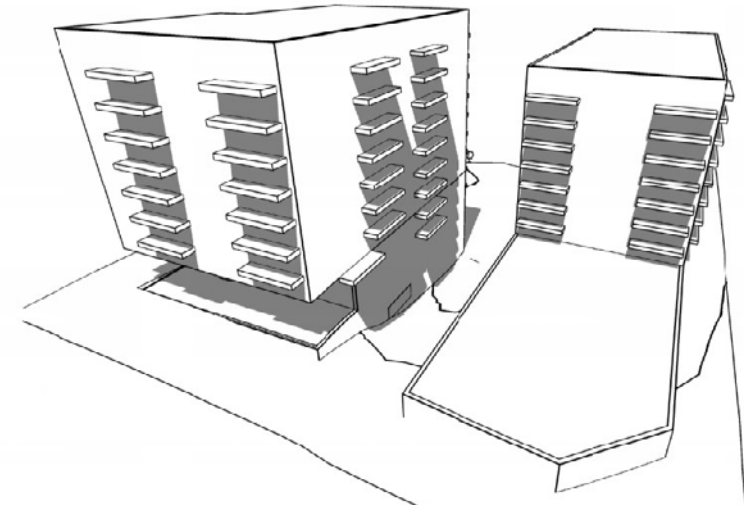

2 - AERIAL VIEW FROM INTERSECTION

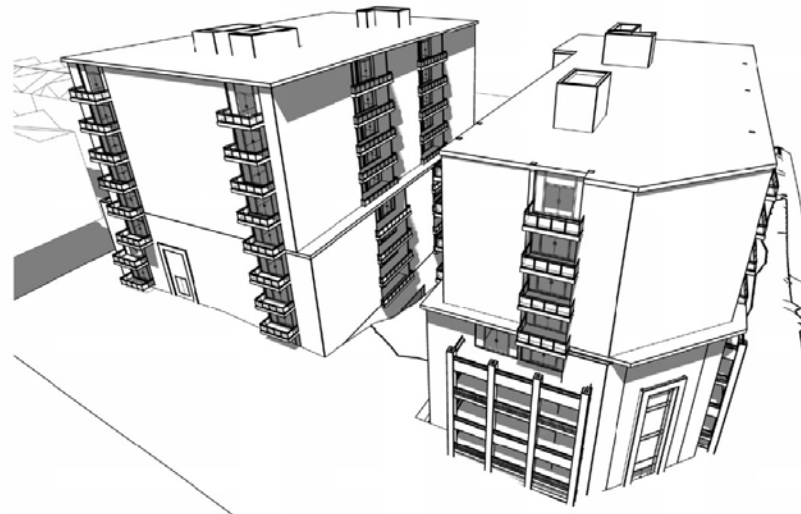

3 - AERIAL VIEW FROM INTERSECTION

MASSING DEVELOPMENT

As presented for City Pre-Consult



4 - AERIAL VIEW FROM INTERSECTION



5 - STREET VIEW FROM INTERSECTION



6 - STREET VIEW FROM ST. JOSEPH BOULEVARD

MASSING DEVELOPMENT

As presented to informal consult with UDRP



7 - AERIAL VIEW FROM INTERSECTION



8 - STREET VIEW FROM INTERSECTION

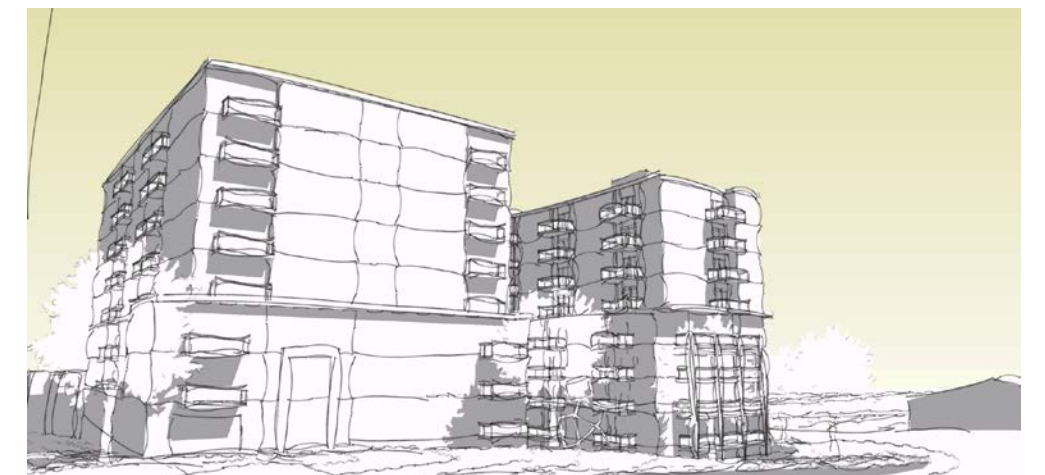

9 - STREET VIEW FROM ST. JOSEPH BOULEVARD





**1 - EAST ELEVATION - TENTH LINE ROAD**



**2 - NORTH ELEVATION - REAR**



**3 - WEST ELEVATION - NEIGHBOURING PARKING LOT**



**4 - SOUTH ELEVATION - ST. JOSEPH BOULEVARD**





1 - AERIAL VIEW FROM INTERSECTION OF *ST JOSEPH BOUL. & TENTH LINE RD*



2 - SOUTHERN AERIAL VIEW FROM *TENTH LINE ROAD*



3 - AERIAL VIEW FROM NORTHERN END OF SITE ABOVE *ERIC CZAPNIK WAY*



4 - NORTHERN AERIAL VIEW FROM *ST. JOSEPH BOULEVARD*



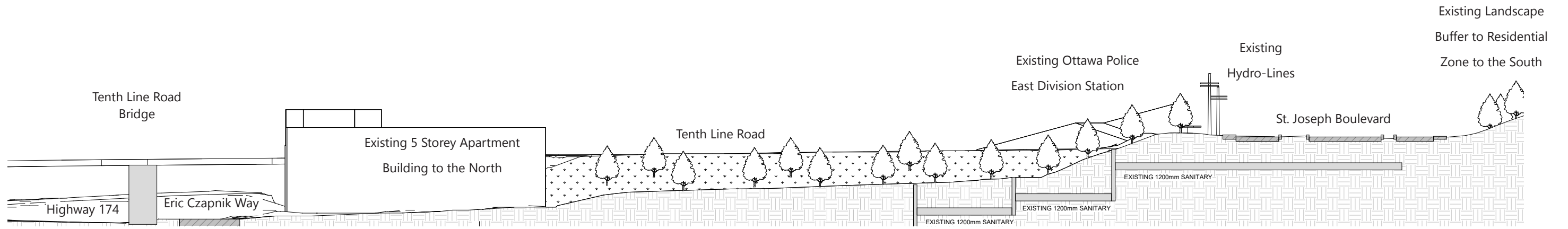

**1 - EXISTING LONGITUDINAL SECTION THROUGH PROPERTY**

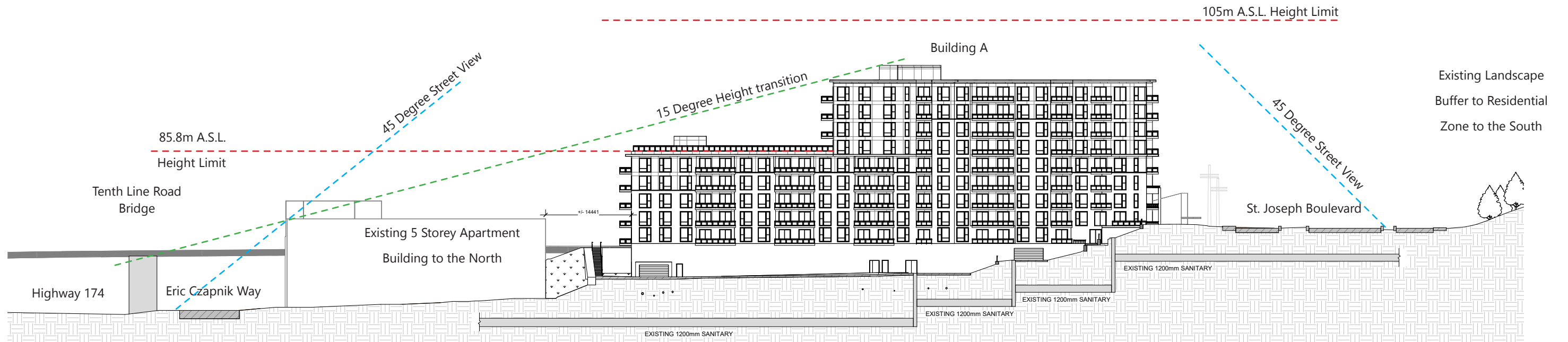

**2 - PROPOSED LONGITUDINAL SECTION THROUGH PROPERTY**

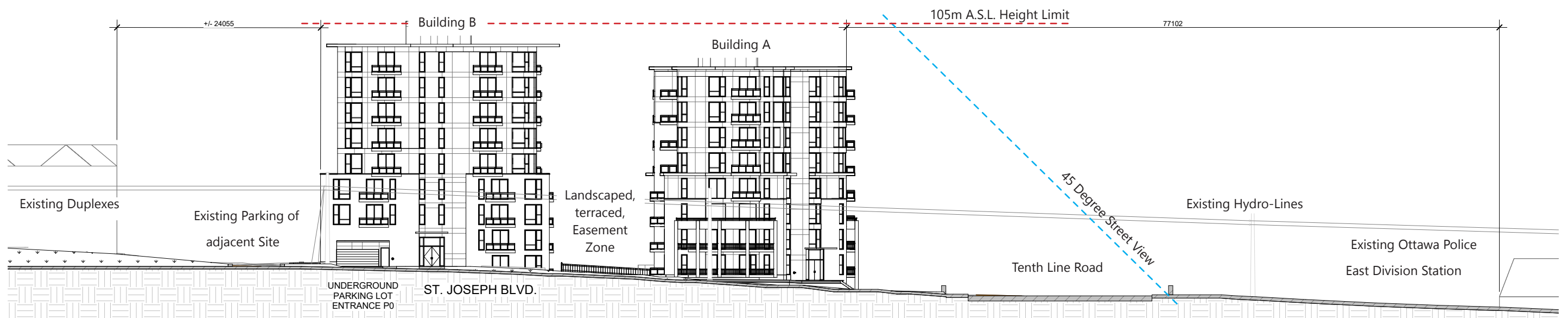

**3 - PROPOSED TRANSITIONAL SECTION FROM ST. JOSEPH BOULEVARD**



## PUBLIC REALM

### Architectural Responses

The proposed development achieves compatibility with the surrounding context through strategic site layout, good building design, appropriate massing and materiality in accordance with 4.11 of the OP. The proposal will also undergo additional reviews of all aspects related to urban design by the Urban Design Review Panel as part of the approval process. In this proposal, multiple architectural design elements were included to contribute to the overall quality of the relationship that the proposed project has with the public realm (*Figure 12.*):

- Street animation is achieved through:
  - Providing various pedestrian links from the building to the street, connecting the project to the existing pedestrian and cyclist networks through landscaped buffers for the users and the public to utilize while transitioning from the public to the private;
  - Connecting these links to the more residential area through Lionel-Rheo Private way at the north end of the property, promoting movement through the site from the arterial main street to the secondary roads;
  - Walk-out gardens provided on grade for some units as best as the grading allows along Tenth-Line Road;
  - The creation of landscaped terraces between the two buildings, in response to grade challenges, which also embraces more intimate amenity spaces;
  - Limiting building services to the northern rear of the site, furthest from the arterial main streets;
- Three storey porch projections are proposed along Tenth-Line Road which helps to transition the mid-rise nine storeys towers through to a more relatable human scale.
- Materials are almost entirely masonry or aluminium panels of higher quality which contributes to the durability and overall quality of the public experience.
- Maximum feasible space has been proposed between and around buildings to maximize the potential space available for soft landscaping features. Lush trees and shrubs will also assist in providing shade to pedestrians and a more sustainable temperature management for the ground floor areas given the generous glazing throughout.

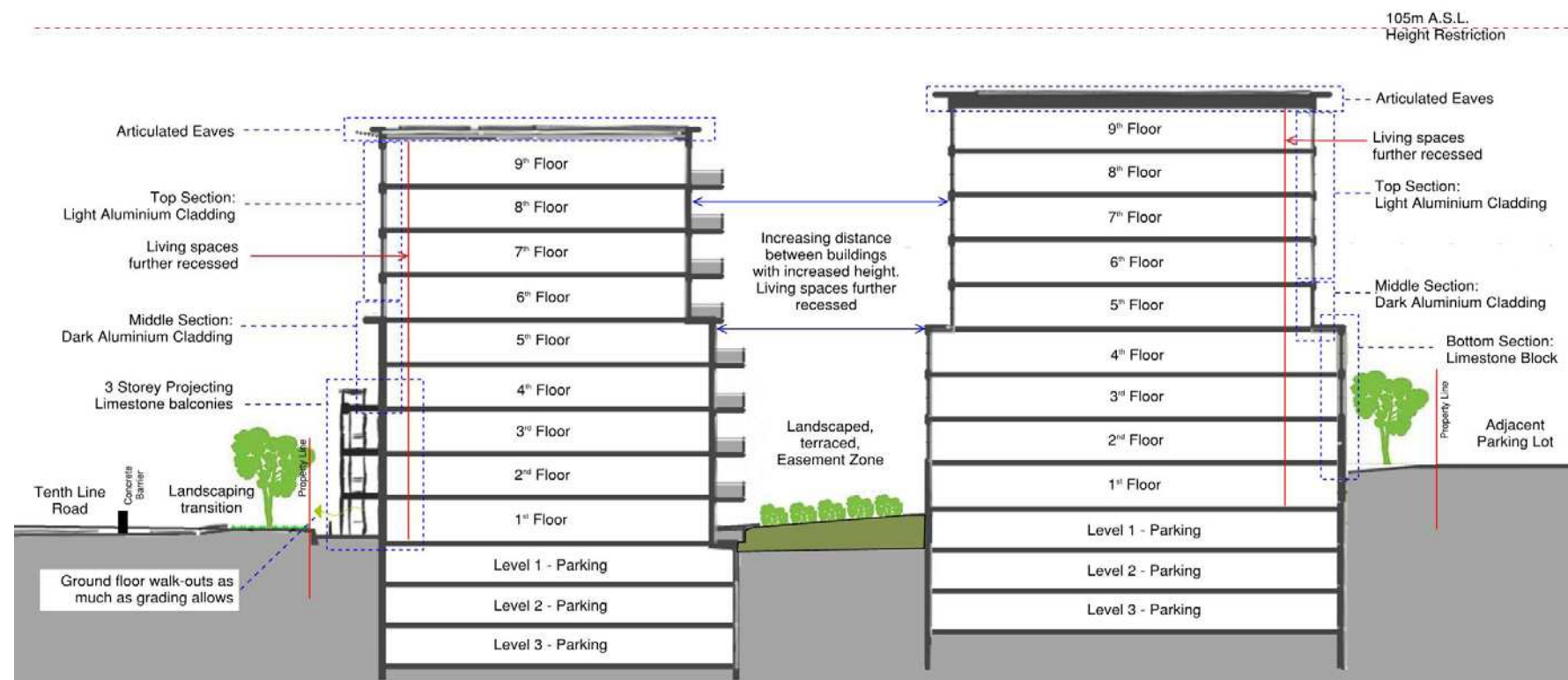

Figure 12. - Diagrammatic Section showing transition to the Public Realm

### Landscaping Details

Ground level landscaping along St. Joseph Boulevard and, as much as possible, along Tenth Line Road is designed to enhance the pedestrian experience by helping to soften the mass of the building. Along Tenth-Line Road, due to the concrete barrier and change in grade, tree beds, shrubs and soft landscaping help to provide shade to pedestrians and residents while being a buffer between the busy road, harsh barrier and residential units. Landscaped areas have also been proposed along the sidewalks and pathways to enhance the transition from the public to the private realm.

Adjacent to St. Joseph Boulevard, at the south end of the development between the two buildings, a public space will be accommodated as best as possible, tying the main entrances together. It should be noted, however, that proximity to the R.O.W. coupled with the natural grading greatly limits the possibility of a central outdoor space.

At the north end of the site, hard landscaping surfaces have been provided in order to cater for vehicular access and service access while maintaining minimal permanent features per the city requirements over the sanitary easement. Due to the extensive nature of the works, it is unlikely that many existing trees will be able to be conserved.

### Design Priority Areas (in accordance with Official Plan Section 4.11.)

The proposed development is located within a designated Mixed Town Centre which is an area where intensification is currently being targeted. This also means that the proposed development will be subject to a formal design review by the Urban Design Review Panel to demonstrate how the proposed design satisfies the various Town Centre site specific policies.

Though the site falls within a Mixed Use Centre, the project is focused predominantly on residential dwellings, in part due to the traffic and parking implications of adding a commercial aspect to this corner site on ground floor but also due to the concrete barrier along Tenth-Line, which restricts interaction with the public realm, and the significant grading challenges. Considering that the development will be exclusively residential use with various height restrictions in place and that the grade of the site directly affects the 'first storey', the project does not make use of a higher first storey but rather focuses on the primary entrances having a higher or double-volume space to be better highlighted and interact with the public realm. Entrances face the main intersection and St. Joseph arterial street while facades have been located parallel to the street with architectural elements, including projected porches and alcoves to soften the interface between the buildings and the public realm. Cladding materials highlight vertical and horizontal transitions while unifying the entire development.

The significant grade difference on the site constrains private and public interaction but a concerted effort has been made to embrace the site as well as the space between the buildings, as created by the easement access, so as to create several intimate amenity areas which can be enjoyed by residents. This is mostly the case for the street frontage along St. Joseph, which incorporates landscaping, softening the transition from the public realm.



## BUILDING DESIGN (in accordance with Official Plan Sections 4.11 and 5.2.1)

### Site Layout

The proposed development is a residential-use building providing Two Hundred and Seventy Four (274) rental units ranging from studios to three (3) bedrooms. The development is composed of two (2) residential towers with three (3) distinctive volumes of various heights. Two nine (9) storey towers along St. Joseph Boulevard and a lower five (5) storey 'leg' topped with a communal rooftop terrace along Tenth Line. Amenity spaces totalling over three thousand square meters (3067.68m<sup>2</sup>) are provided split between private balconies, exterior areas both at grade and on the sixth floor plate roof terrace, as well as an interior gym and common room.

In order to alleviate congestion on the busy Tenth-Line and St. Joseph Boulevard intersection, vehicular access to the site is proposed from both St. Joseph (as far from the intersection of Tenth-Line as possible) as well as from Lionel-Rheo Private which connects to Eric Czapnik Way at the rear of the site. Each access is made up of a six meter laneway leading to two linked three-level parking garages for a total of one hundred and eighty four (184) spaces. Also incorporated is a covered rear drop-off area leading to the parking garage which also doubles as a 'hammerhead' for service vehicles. Additionally, one hundred and thirty seven (137) bicycle bays are provided on the garage level of Building 'B', closest in elevation to St. Joseph, with convenient access directly to St. Joseph or alternatively through the parking garage levels to the lower portion of the site.



Due to the gradient challenges of the site, the access to the bicycle parking has been accommodated using a 'stair rail' system (Figure 13.) to allow the use of stairs to access the bicycle parking area easily despite the necessity of stairs. Alternative, stair-free access is also provided through the parking levels directly to St. Joseph Boulevard or Lionel-Rheo Private through the garage link.

Figure 13. Stair Rail System

Being in "Area Z: Near Major LRT Stations" per 'Schedule 1A' (By-Law 2008-250), there is no requirement for resident parking, making the total required parking Twenty-Seven (27) in the form of visitors spaces. Despite this, an additional one hundred and fifty seven (157) spots have been provided for the project to be viable.

Building entrances are located on St. Joseph for building 'B' and the intersection of Tenth Line and St. Joseph Boulevard for building 'A'. This was done not only due to the concrete barrier along Tenth Line as it bridges Highway 174, but also to promote animation and easy access to the pedestrian network and public transit stops located along St. Joseph Avenue. In addition to the two primary residential entrances on St. Joseph Avenue and the prominent intersection, there are also four additional entrances to the various garage levels to cater for pedestrians and servicing from the lower portion of the site through Lionel-Rheo Private from Eric Czapnik Way, including bulky delivery or moving services directly to the lift cores of Buildings A and B from the central 'easement'.

The buildings have been positioned along all setbacks to allow as much space as possible between the two residential towers where the city easement restricts any permanent structures of any kind. The site's topography also influenced the positioning of the building as there is a significant change in grade (roughly 10m) from the southwest corner of the site on St. Joseph Boulevard to the rear receiving and access area of the site near the quieter Eric Czapnik Way.

### Materiality

The design takes on the base, middle and top approach to its massing along all elevations to enhance both the pedestrian experience at street level and the building's expression and image in the urban fabric. The materiality also contributes in reinforcing the horizontal and vertical separation of each component.

The Podium of heavier limestone or architectural block (Figure 14.), representing the first three to four levels, is designed to have a more urban and modern interface with the public realm while having a more relatable three storey scale to animate and enhance the experience at street level. Dark and light metallic elements are also added to vertically articulate and tie together the three distinct portions.

The middle section consists of dark metallic panels (Figure 15.) which creates a distinct horizontal, and in some place vertical, separation between the base and the top section of the building.

The top portion consists of light metallic panels (Figure 16.) which also tie down vertically to the second storey in parts. The selected colours of the materials runs lighter from base to top to help reduce the massing effects.

The design also incorporates a more contemporary window pattern and dimensioning which gives the building a more current look while being sympathetic to the character of the area.



Figure 14.  
Architectural Stone - "Lexa Stone"  
by Ottawa Brick & Stone



Figure 15.  
Aluminium Panels - "Buick"  
by Alucobond

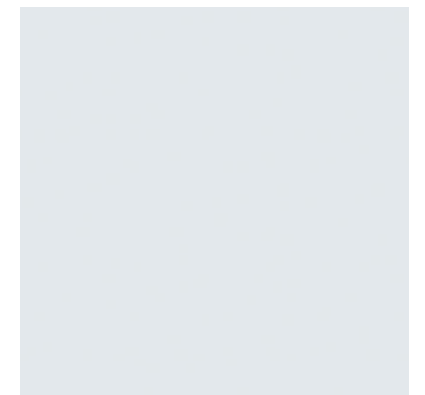

Figure 16.  
Aluminium Panels - "Magnolia"  
by Alucobond

### Amenity Areas

A proposed mix of indoor and outdoor amenity space, both private and communal, has been provided throughout the development in key areas. Communal areas total roughly 934m<sup>2</sup>, while private spaces boast a combined area of 2134m<sup>2</sup>. Notably, the near six hundred square meter (602m<sup>2</sup>) terrace on the rooftop of the northern section of Building A, accessible through the 6th level floor plate, provides users with an elevated view of the Ottawa river. Additionally, interior areas including a gym & lounge are provided, for a total of around 244.72m<sup>2</sup> of interior resident amenity area.





1 - STREET VIEW FROM INTERSECTION OF *ST JOSEPH BOULEVARD & TENTH LINE ROAD*





1 - STREET VIEW FROM INTERSECTION OF *ST JOSEPH BOUL. & TENTH LINE RD*



2 - SOUTHERN STREET VIEW FROM *TENTH LINE ROAD*



3 - AERIAL VIEW FROM NORTHERN END OF SITE ABOVE *ERIK CZAPNIK WAY*



4 - NORTHERN STREET VIEW FROM *ST JOSEPH BOULEVARD*





1 - STREET VIEW FROM *ST JOSEPH BOULEVARD*



2 - PEDESTRIAN VIEW FROM SOUTH OF TERRACED EASEMENT



3 - AERIAL VIEW OF TERRACED EASEMENT

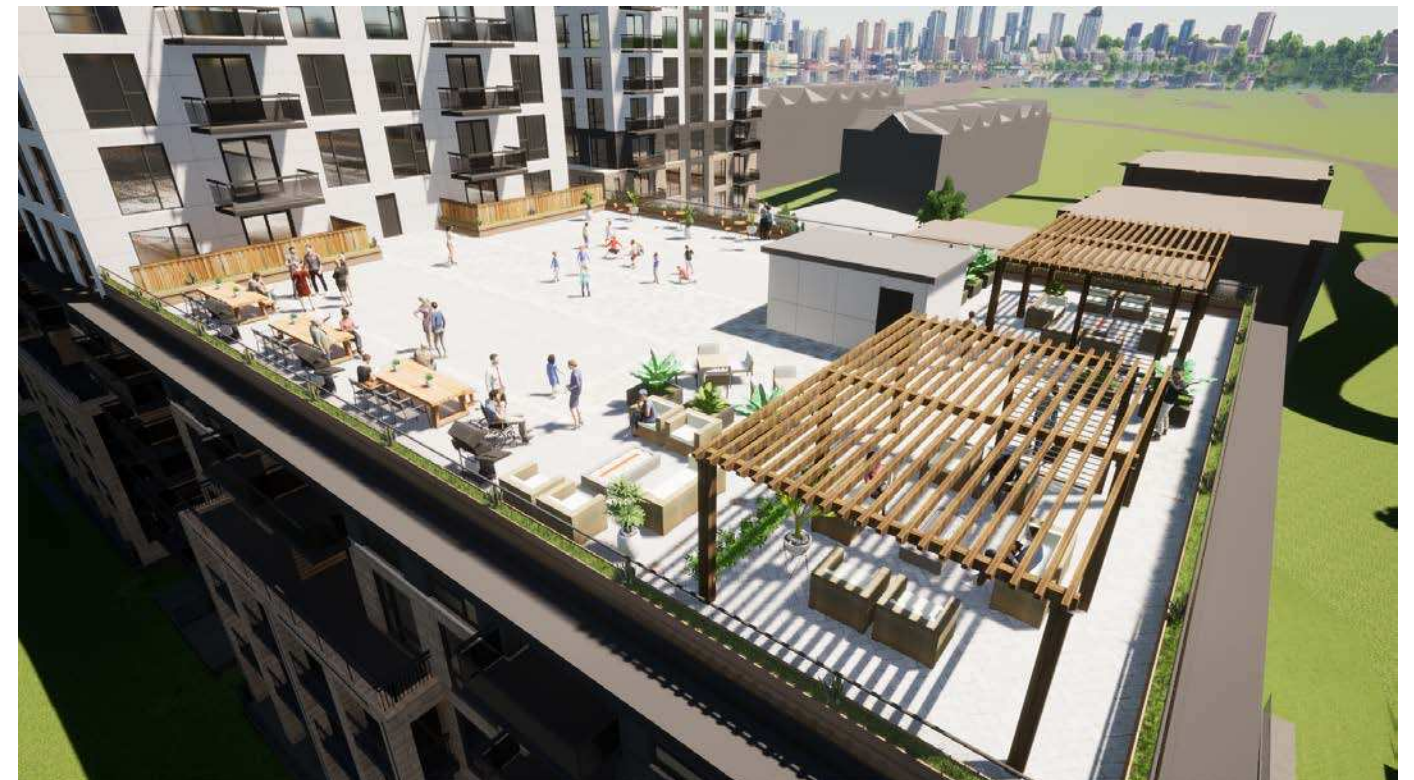

4 - AERIAL VIEW OF ROOFTOP TERRACE



## SUSTAINABILITY

The proposed development contributes to the achievement of City of Ottawa sustainability objectives through site and building design. With a total of two hundred and seventy four (274) residential rental units, the proposed density of the development aids in the creation of a more compact urban form which follows the Mixed Town Centre's intensification orientation. Through various types of units ranging from studios to three bedrooms, the project can respond to a greater variety of residents and help increase accessibility to housing for seniors.

### Building Design

- The building design including envelope as well as heating and cooling systems will optimize energy consumption through modelling to meet and potentially exceed all provincial and federal model requirements;
- The percentage of glass has been minimized by applying punched windows to obtain more energy efficiency;
- The installation of high quality windows that utilize low-e coatings and gas filling, while choosing the glazing and window frame material that will be most sustainable;
- Air-tight building envelope using increased insulation;
- The tower portions of the project extend along the east-west axis which allows the units to take advantage of the South light which creates opportunity for energy efficient design;
- The proposal has paid attention to the implementation of bird friendly design by incorporating more dark materials on the bottom three floors to create higher contrast and by using punch windows which not only allows for less transparent surfaces but also creates interruptions between them. Additionally, on the rooftop terrace level, appropriate glazing will be used for the first 2 levels to minimise bird collisions. (Figure 17.)

### Sustainable Site

- Subject property is located within walking and cycling distance to a variety of local services and amenities to meet daily needs, reducing the reliance on private motor vehicles;
- Subject property is located within 2km of a commercial centre and Rapid Transit Station with a future station, due within a few hundred meters, making it easy to access downtown areas therefore favouring the use of public transport;
- All on-site parking is provided below grade via a three-level parking garage which provides less than a 1 space per unit ratio, with the possibility of incorporating carshare facilities, encouraging the use of public transit and carshare facilities;
- One hundred and thirty seven (137) bicycle parking spaces will be provided to promote active transportation and less dependence on motor vehicles.

### Water Efficiency

- Stormwater will be controlled on site including rooftop flow attenuation and surface and sub-surface storage;
- Landscape design will incorporate indigenous vegetation requiring as little irrigation as possible.

### Energy and Atmosphere

The proposed development also reduces energy consumption through:

- The use of more permeable materials to reduce heat loss;
- Low-flow hot water fixtures;
- Exterior lighting which will be designed to reduce light pollution to a minimum.

### Indoor Environmental Quality

- Operable windows will increase natural ventilation;
- Interior materials and finishes will be selected to ensure durability and low emissivity;
- Units are designed to maximize natural light which will reduce reliance on electrical and mechanical systems.

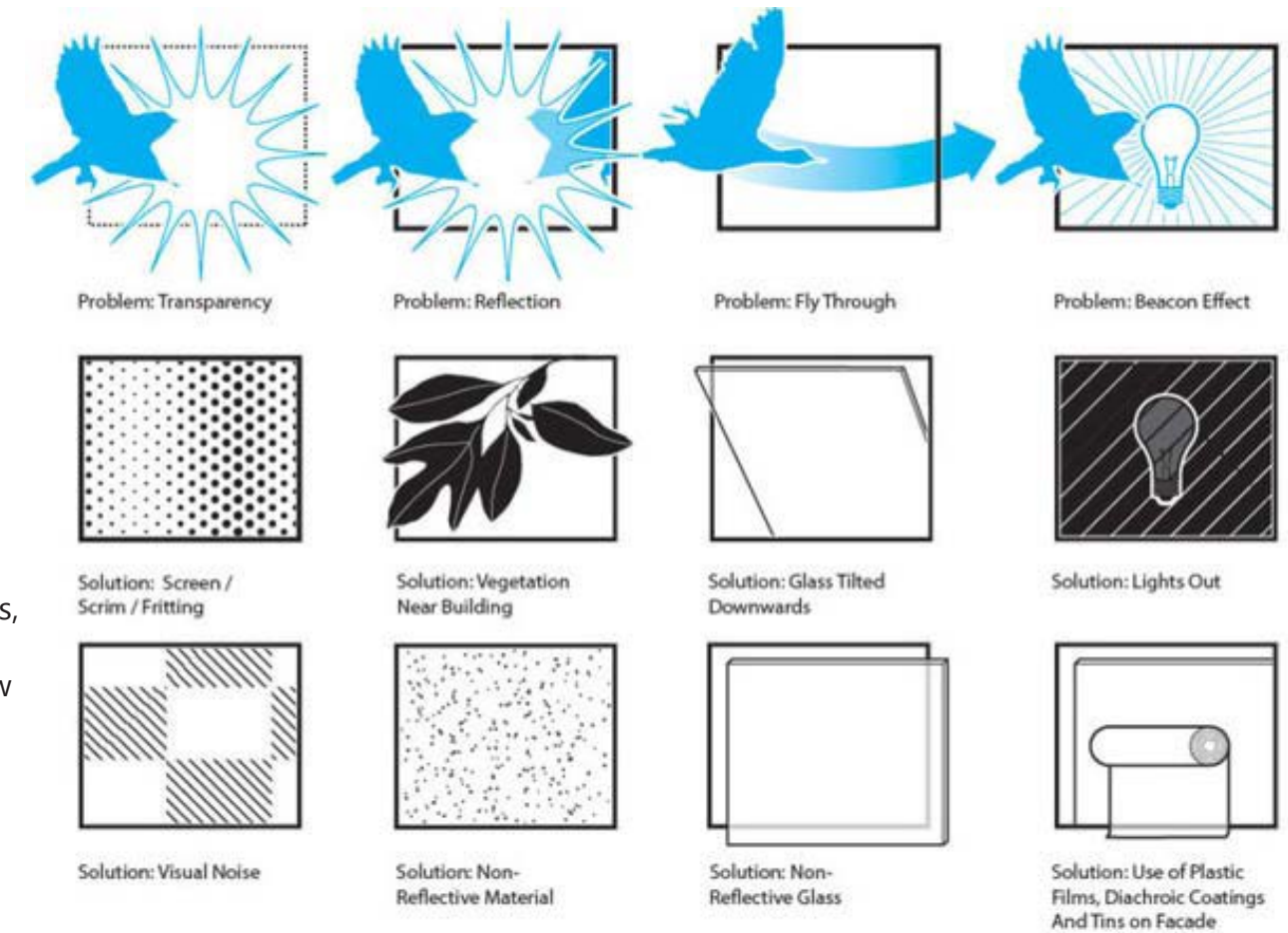

Figure 17. - Bird Safety: Glass problems and Solutions

Image Credit: scapestudio.com

### Materials and Resources

- The building envelope will consist of mostly rain-screen aluminium, architectural stone cladding and punched windows allowing for higher overall energy efficiency which will ensure comfort and an superior energy model performance;
- Construction will favour locally sourced, durable, sustainable, and recycled materials;
- Construction and demolition waste will be reduced and recycled during design, construction, operation, and end of life;
- Roof membranes will have a high solar reflectance index;
- Greening of the roof with planters will reduce heat island effect;
- Storage and collection of recyclables has been incorporated in the project.



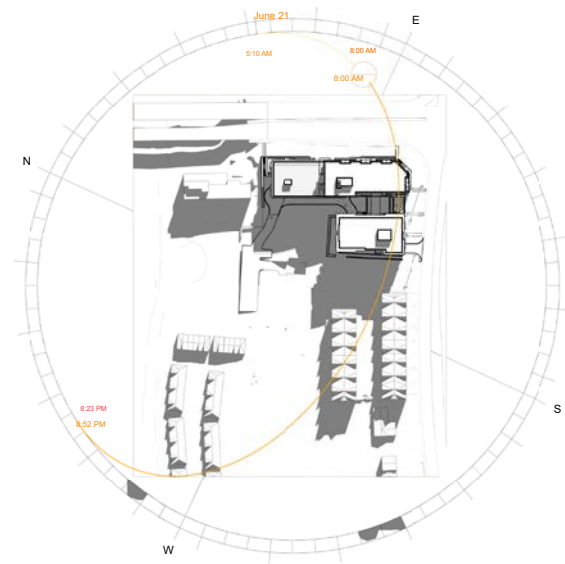

SUMMER SOLSTICE (JUNE 21) 8 AM

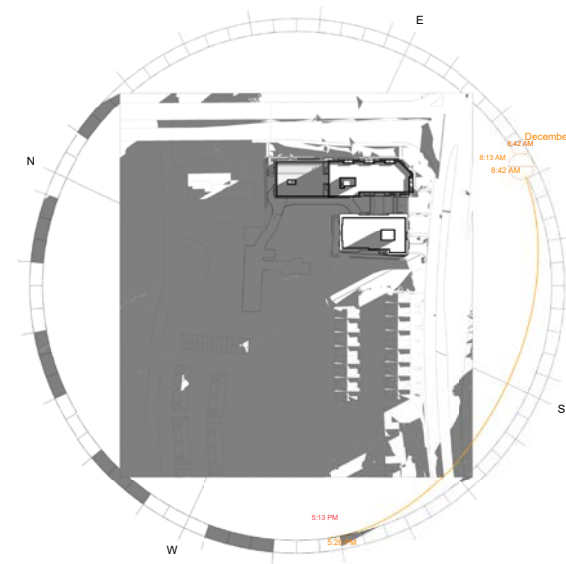

WINTER SOLSTICE (DECEMBER 21) 8 AM

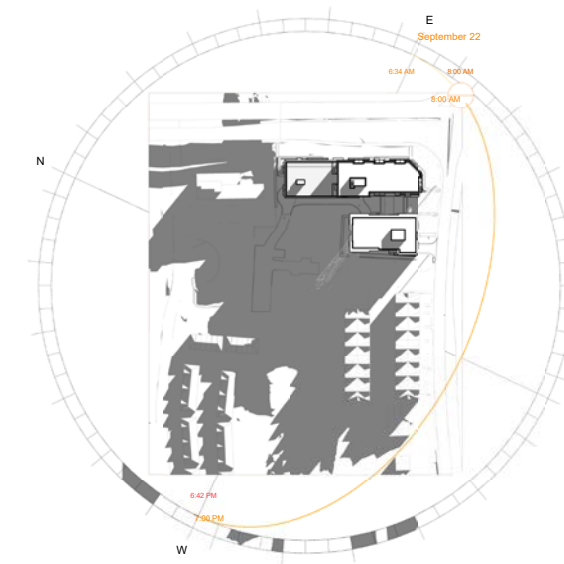

FALL/SPRING EQUINOX (SEPTEMBER/MARCH 21) 8 AM

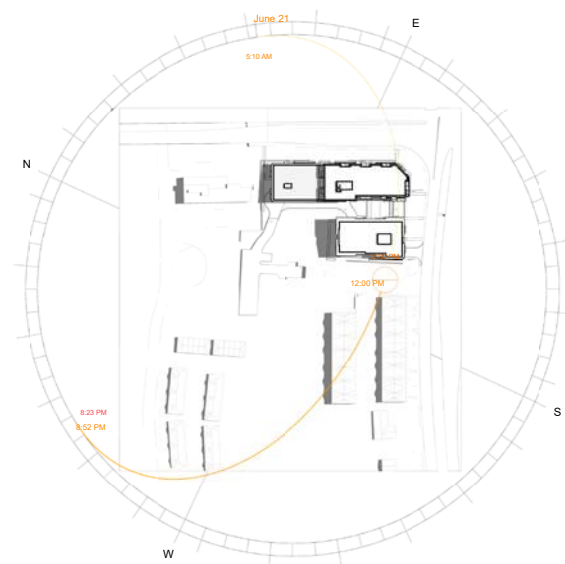

SUMMER SOLSTICE (JUNE 21) 12 PM

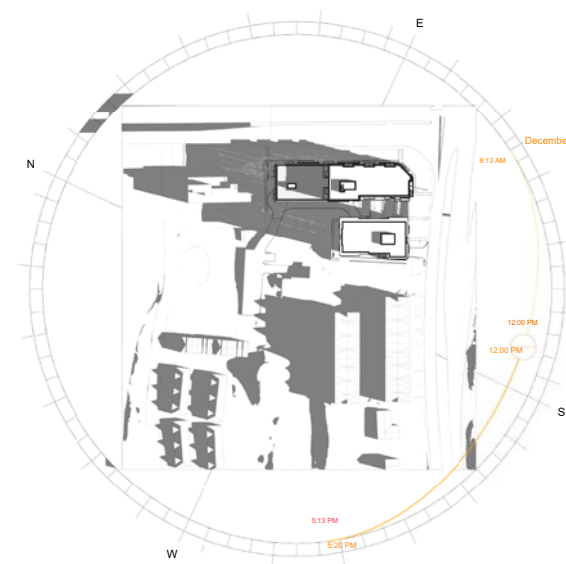

WINTER SOLSTICE (DECEMBER 21) 12 PM

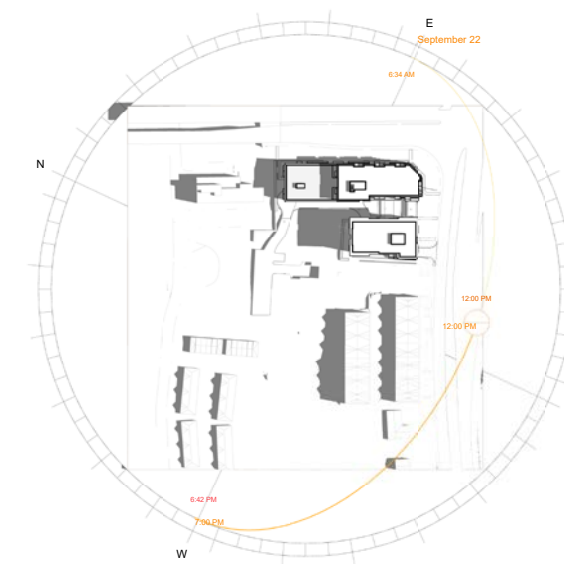

FALL/SPRING EQUINOX (SEPTEMBER/MARCH 21) 12 PM

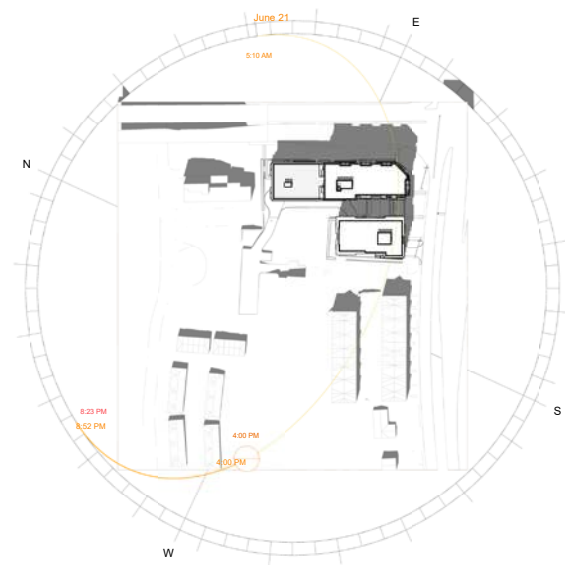

SUMMER SOLSTICE (JUNE 21) 4 PM

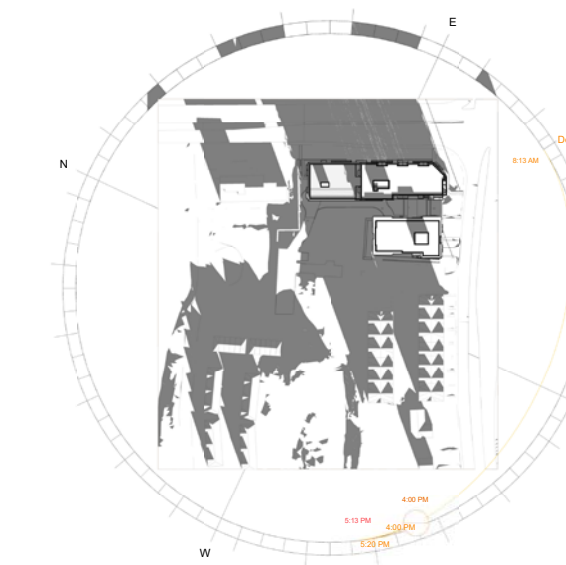

WINTER SOLSTICE (DECEMBER 21) 4 PM

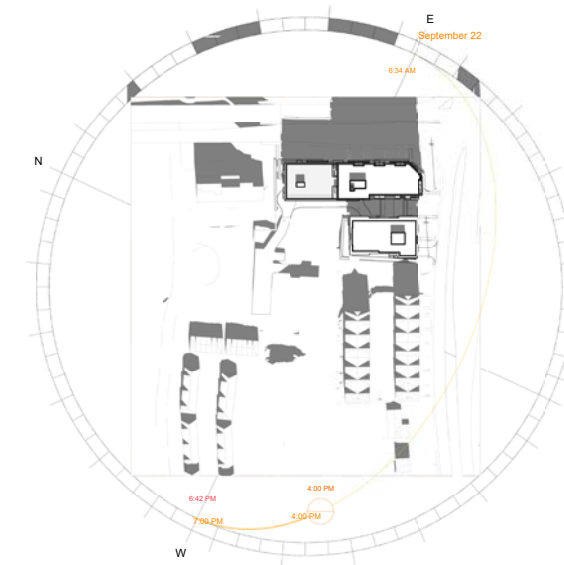

FALL/SPRING EQUINOX (SEPTEMBER/MARCH 21) 4 PM





1 3D VIEW SUMMER SOLSTICE 8AM  
005



2 3D VIEW SUMMER SOLSTICE 12PM  
005

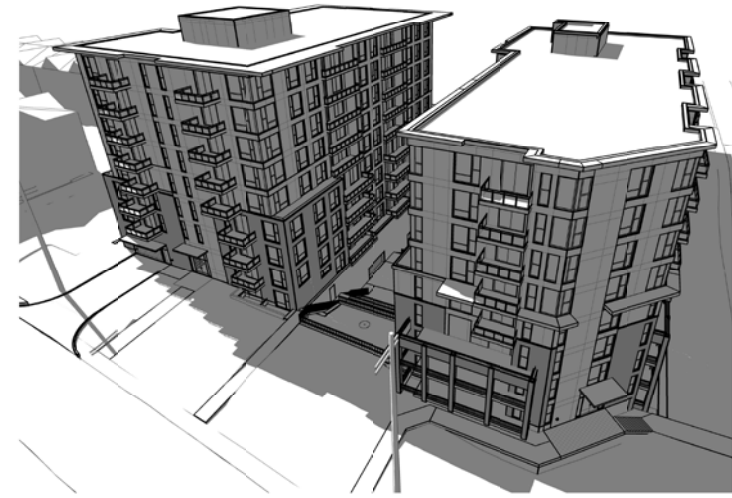

3 3D VIEW SUMMER SOLSTICE 4PM  
005



4 3D VIEW FALL EQUINOX 8 AM  
005



5 3D VIEW FALL EQUINOX 12 PM  
005



6 3D VIEW FALL EQUINOX 4PM  
005

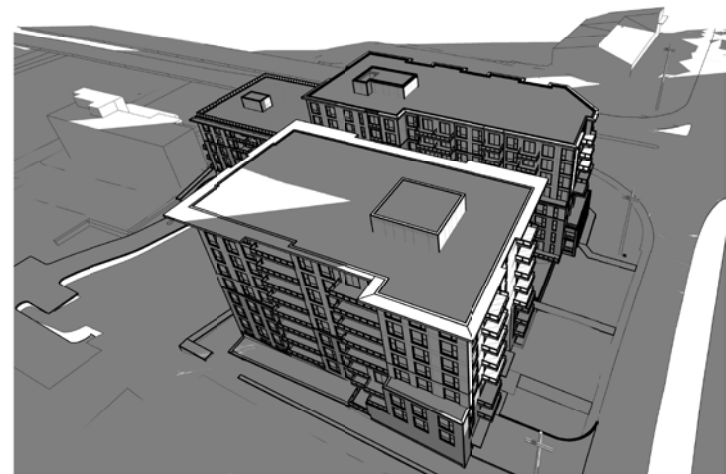

7 3D VIEW WINTER SOLSTICE 8AM  
005

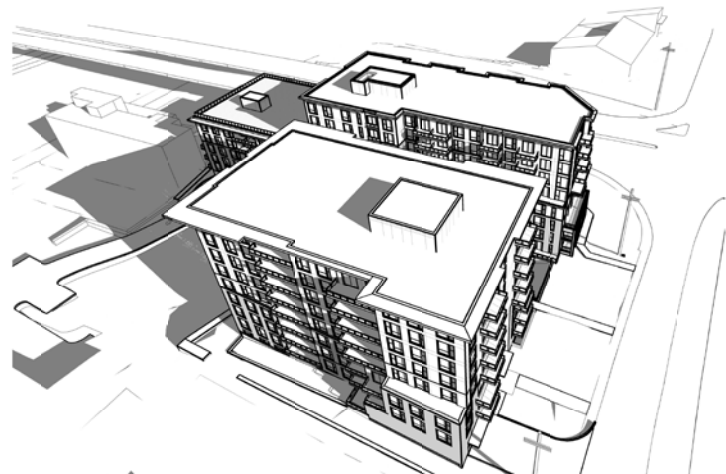

8 3D VIEW WINTER SOLSTICE 12 PM  
005

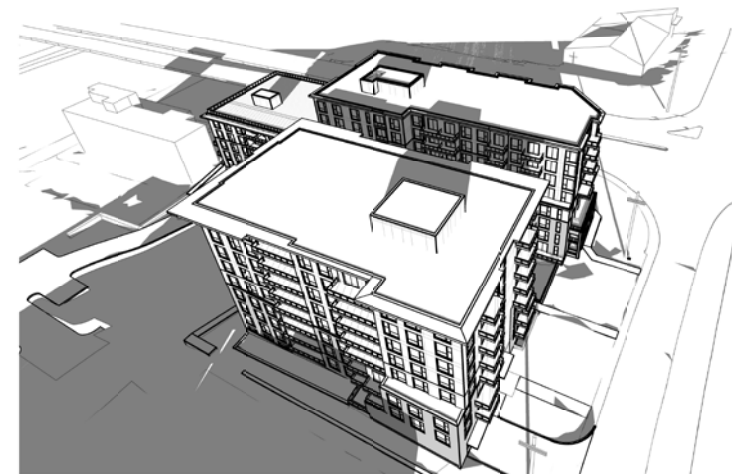

9 3D VIEW WINTER SOLSTICE 4PM  
005



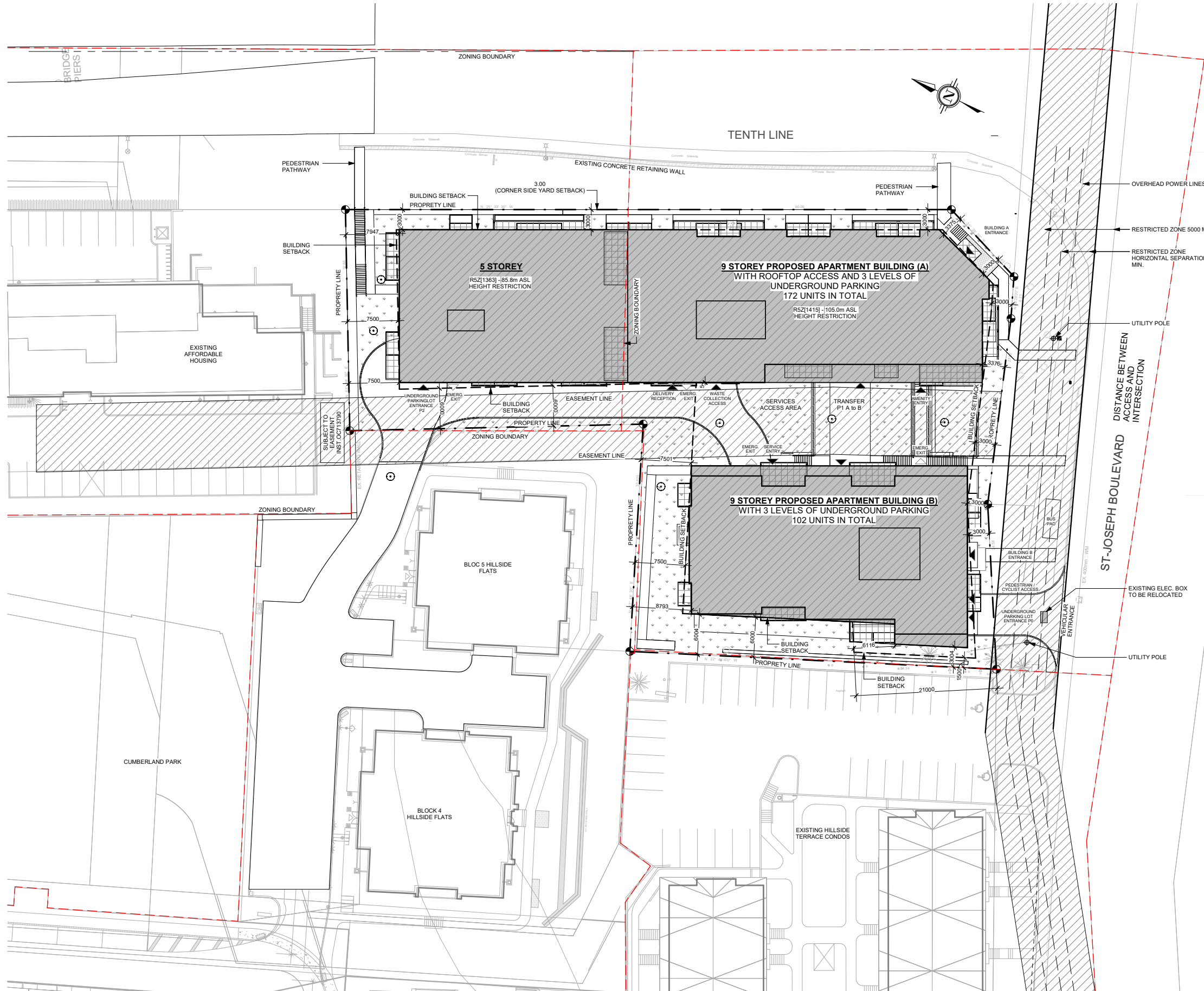

**SITE PLAN LEGEND**

- NEW CONSTRUCTION - BUILDING
- NEW CONSTRUCTION - RETAINING WALL
- GRASS
- INTERLOCK PATHWAY
- CONCRETE PATHWAY
- BUILDING ACCESS / EXIT
- PROPERTY LINE
- SETBACK LINE
- ZONING LINE
- TREE/BUSH

**GENERAL NOTES**

- NOTE A: NO PERMANENT BUILDING OR STRUCTURE SHALL BE PLACED WITHIN 5000MM MEASURED RADIALLY FROM ANY PRIMARY VOLTAGE CONDUCTOR OR EQUIPMENT MEASURED FROM THE CLOSEST PRIMARY CONDUCTOR (AT REST) TO THE CLOSEST POINT OF THE BUILDING OR STRUCTURE
- NOTE B: ALL DRAWINGS ARE TO BE READ IN CONJUNCTION WITH ALL OTHER DRAWINGS AND SPECIFICATIONS. ANY DISCREPANCIES BETWEEN DRAWINGS WILL BE REPORTED TO THE PROJECT LEAD IMMEDIATELY FOR CLARIFICATION PRIOR TO COMMENCE ANY CONSTRUCTION
- NOTE C: ALL GENERAL SITE INFORMATION AND CONDITIONS HAVE BEEN COMPILED FROM EXISTING PLANS AND SURVEY
- NOTE D: CONTRACTOR IS RESPONSIBLE TO CHECK AND VERIFY ALL DIMENSIONS ON SITE AND REPORT ALL ERRORS AND / OR OMISSIONS TO THE ARCHITECT.
- NOTE E: ALL CONTRACTORS MUST COMPLY WITH ALL CURRENT APPLICABLE CODES, REGULATIONS AND BYLAWS
- NOTE F: DO NOT SCALE DRAWINGS.

**PROJECT INFORMATION STATISTICS**

**SITE SUMMARY**  
 ADDRESS: 3277 ST-JOSEPH-BOULEVARD  
 ZONING: RSZ (1415), RSZ (1363), RSZ(2168)  
 SITE AREA: 4965.04 m<sup>2</sup>  
 PROPOSED USE: RESIDENTIAL APARTMENTS (274 UNITS)  
 3 LEVELS OF UNDERGROUND PARKING

**ZONING SUMMARY**

	REQUIRED	PROPOSED
MIN LOT AREA:	1000 m <sup>2</sup>	4965.04 m <sup>2</sup>
MIN LOT WIDTH:	25 m	68.63 m
BUILDING HEIGHT:	10 storeys	9 storeys

**MIN YARD SETBACKS**

	REQUIRED	PROPOSED
FRONT YARD:	3 m	3 m
CORNER SIDE YARD:	3 m	3 m
REAR YARD:	7.5 m	7.5 m
INTERIOR SIDE YARD:	1.5-6 m	3-6 m

**VEHICULAR PARKING**

	REQUIRED	PROPOSED
RESIDENTIAL APARTMENTS (274) UNITS EXEMPT UNDER ZONE Z:	0	157
VISITOR PARKING (274-12) UNITS AS PER TABLE 102	27	27
TOTAL VEHICULAR PARKING:	27	184
ACCESSIBLE PARKING (INCLUDED IN TOTAL PARKING COUNT)	1	3

**BICYCLE PARKING**

	REQUIRED	PROPOSED
RESIDENTIAL APARTMENTS (274) UNITS AS PER TABLE 111A	137	137

**WASTE MANAGEMENT CONTAINERS**

	REQUIRED	AMOUNT
<b>BUILDING 'A' - 172 UNITS</b>		
GARBAGE (172 X 0.11Y = 18.92Y)	4Y <sup>3</sup>	5
RECYCLING (172 X 0.038Y = 6.54Y)	4Y <sup>3</sup>	2
ORGANICS (240L per 50 UNITS = 4)	240L	4
<b>BUILDING 'B' - 102 UNITS</b>		
GARBAGE (102 X 0.11Y = 11.22Y)	4Y <sup>3</sup>	3
RECYCLING (102 X 0.038Y = 3.88Y)	4Y <sup>3</sup>	2
ORGANICS (240L per 50 UNITS = 3)	240L	3

**BUILDING SUMMARY**

	GROSS FLOOR AREA	UNIT COUNT
LEVEL P3 PARKING:	1972.82 m <sup>2</sup>	47
LEVEL P2 PARKING:	2940.47 m <sup>2</sup>	55
LEVEL P1 PARKING:	2940.47 m <sup>2</sup>	64
LEVEL P0 PARKING:	1108.67 m <sup>2</sup>	18
GROUND FLOOR:	2952.49 m <sup>2</sup>	30
LEVEL 2-9:	18721.19 m <sup>2</sup>	244
TOTAL (res units):	21673.64 m <sup>2</sup>	274

**AMENITY SPACE**

	REQUIRED	PROPOSED
6m <sup>2</sup> REQUIRED PER UNIT:	1644m <sup>2</sup>	2134.1m <sup>2</sup>
COMMUNAL AMENITIES (50%):	822m <sup>2</sup>	933.58m <sup>2</sup>
TOTAL:	1644m <sup>2</sup>	3067.68m <sup>2</sup>

**BREAKDOWN:**

PRIVATE TERRACES / BALCONIES 'A'	1483.5m <sup>2</sup>
PRIVATE TERRACES / BALCONIES 'B'	650.6m <sup>2</sup>
COMMUNAL ROOF TERRACE:	602m <sup>2</sup>
COMMUNAL GYM:	86.86m <sup>2</sup>
COMMUNAL GROUND FLOOR:	113.81m <sup>2</sup>
COMMUNAL EXTERIOR GRADE:	130.91m <sup>2</sup>

**UNIT STATISTICS**

	PROPOSED
1 BEDROOM STUDIO:	9 units ( 3.28%)
1 BEDROOM:	111 units (40.51%)
1 BEDROOM + DEN:	83 units (30.29%)
2 BEDROOM:	69 units (25.18%)
3 BEDROOM:	2 units ( 0.72%)



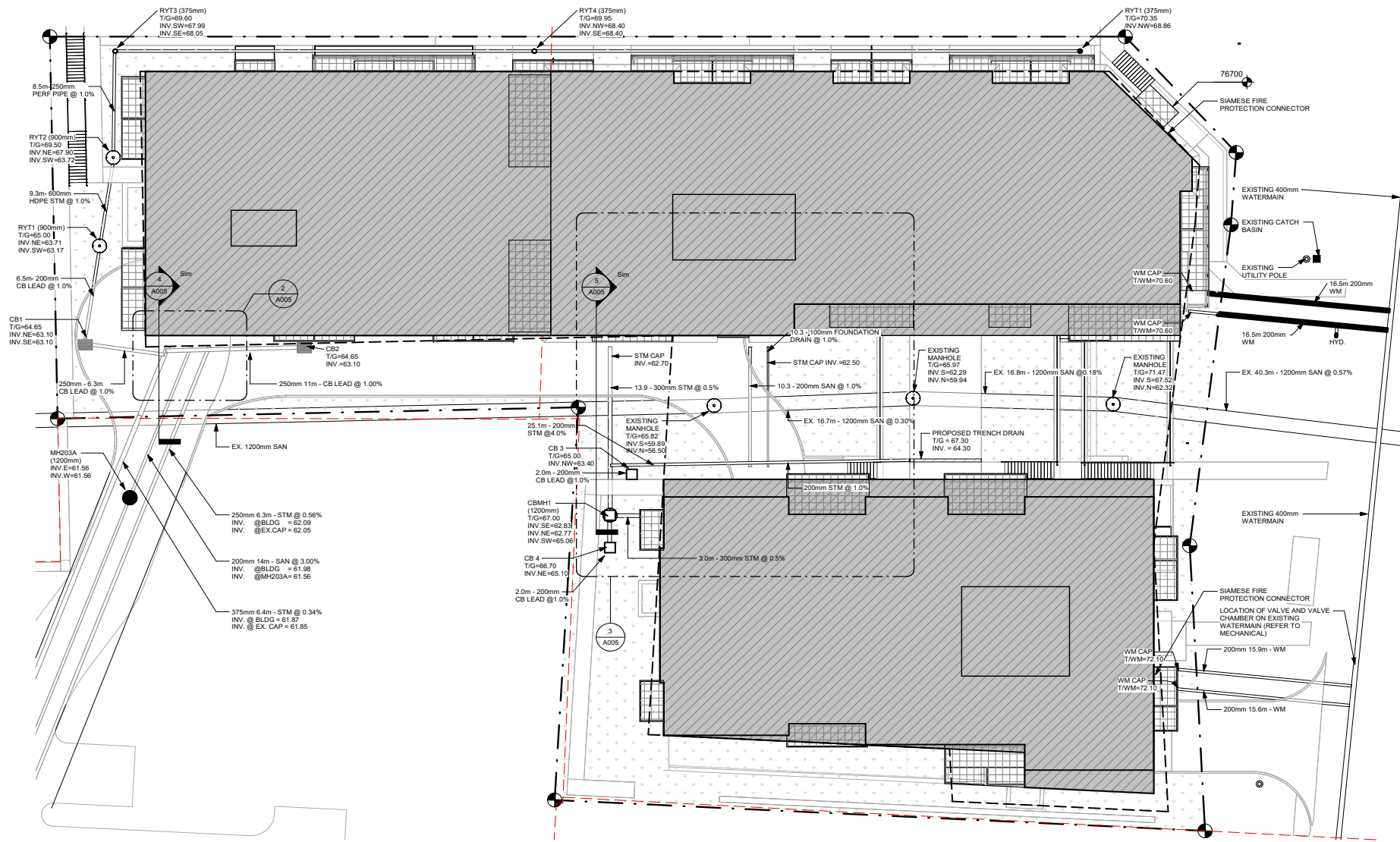

1 SITE PLAN - SERVICE HOOKUPS  
1: 200

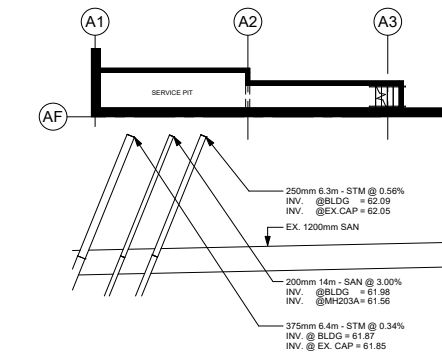

2 SERVICE HOOK UP ROOM  
1: 150

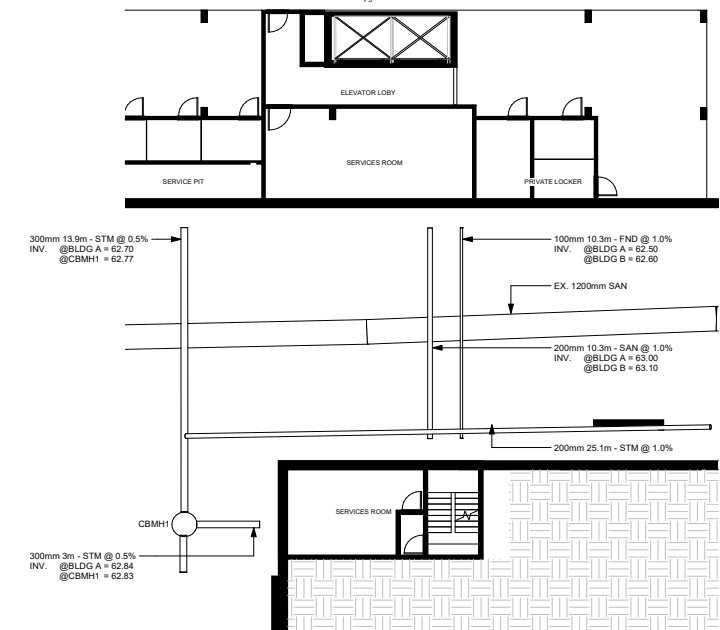

3 SITE PLAN - SERVICE HOOKUPS BETWEEN BUILDING A & B  
1: 150

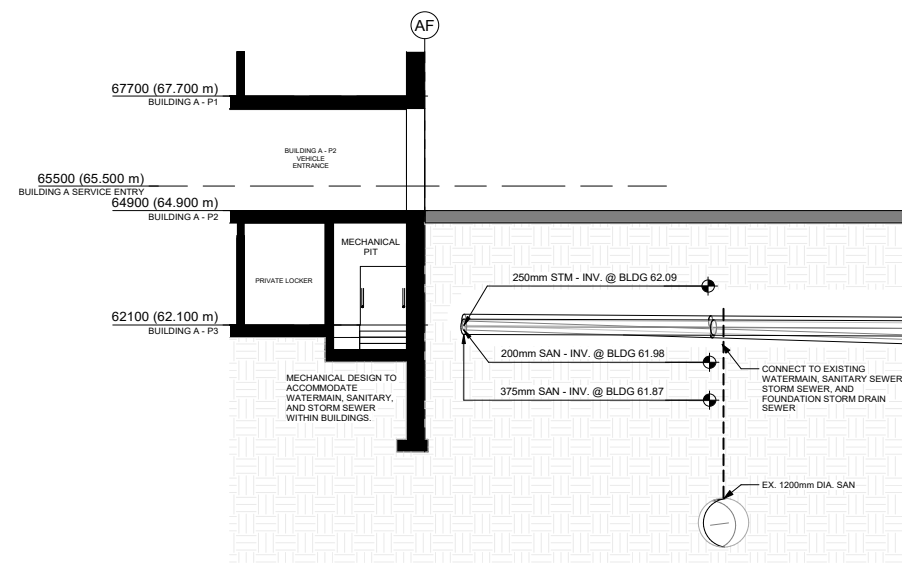

4 BUILDING A - SECTION - SERVICE HOOKUPS  
1: 75

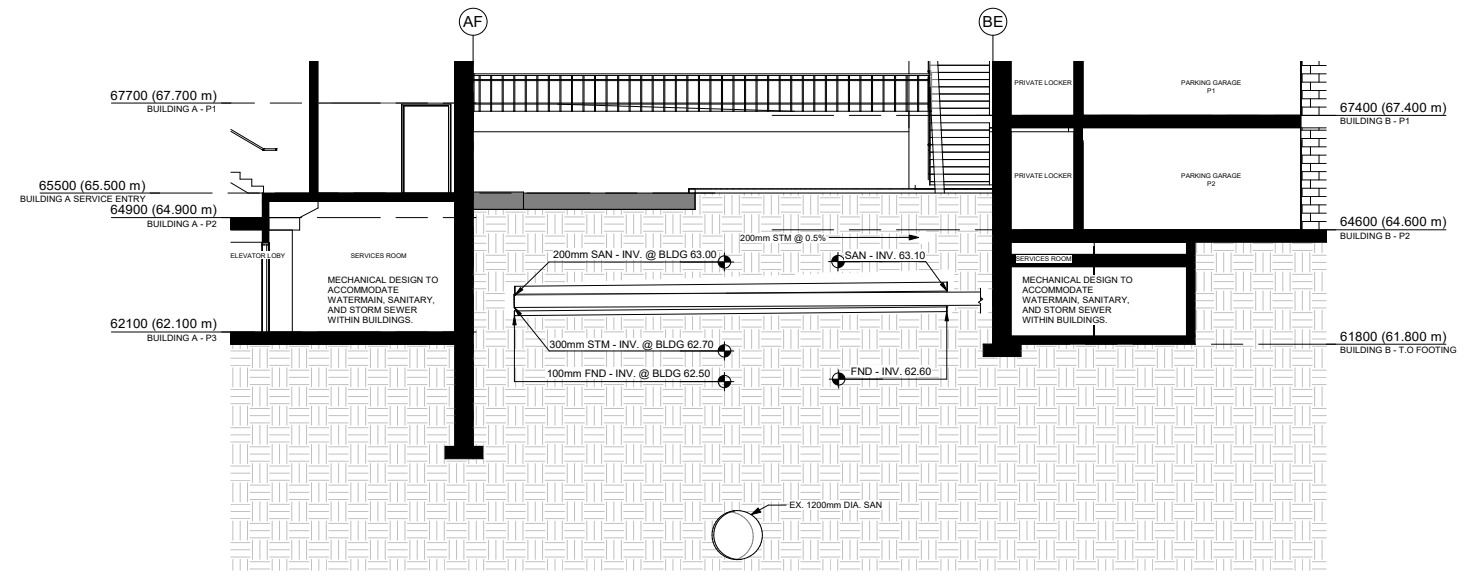

5 BUILDING A&B - SECTION - SERVICE HOOKUPS  
1: 75



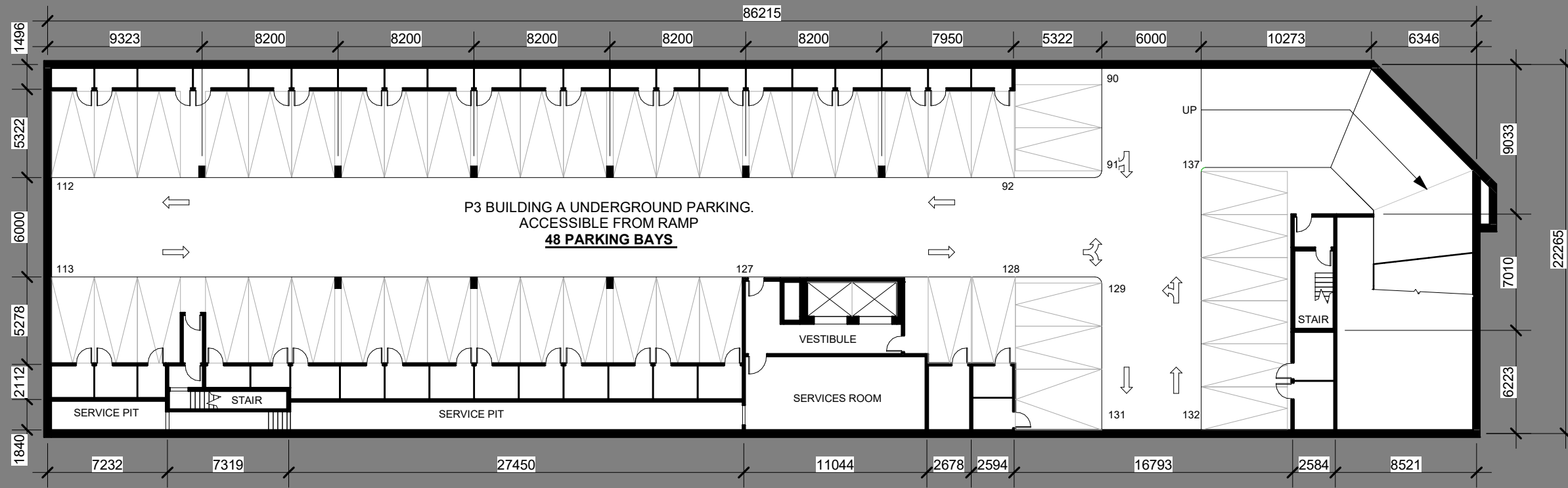

1 BUILDING A - P3  
108 1 : 300

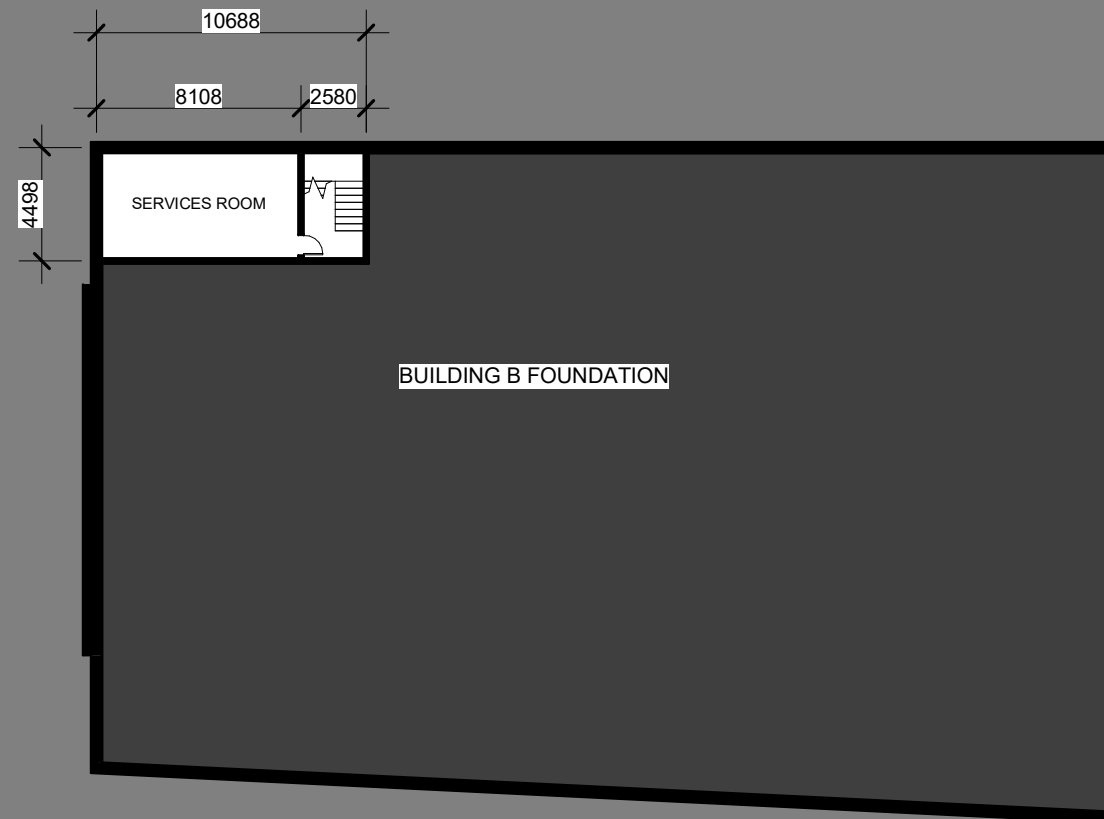



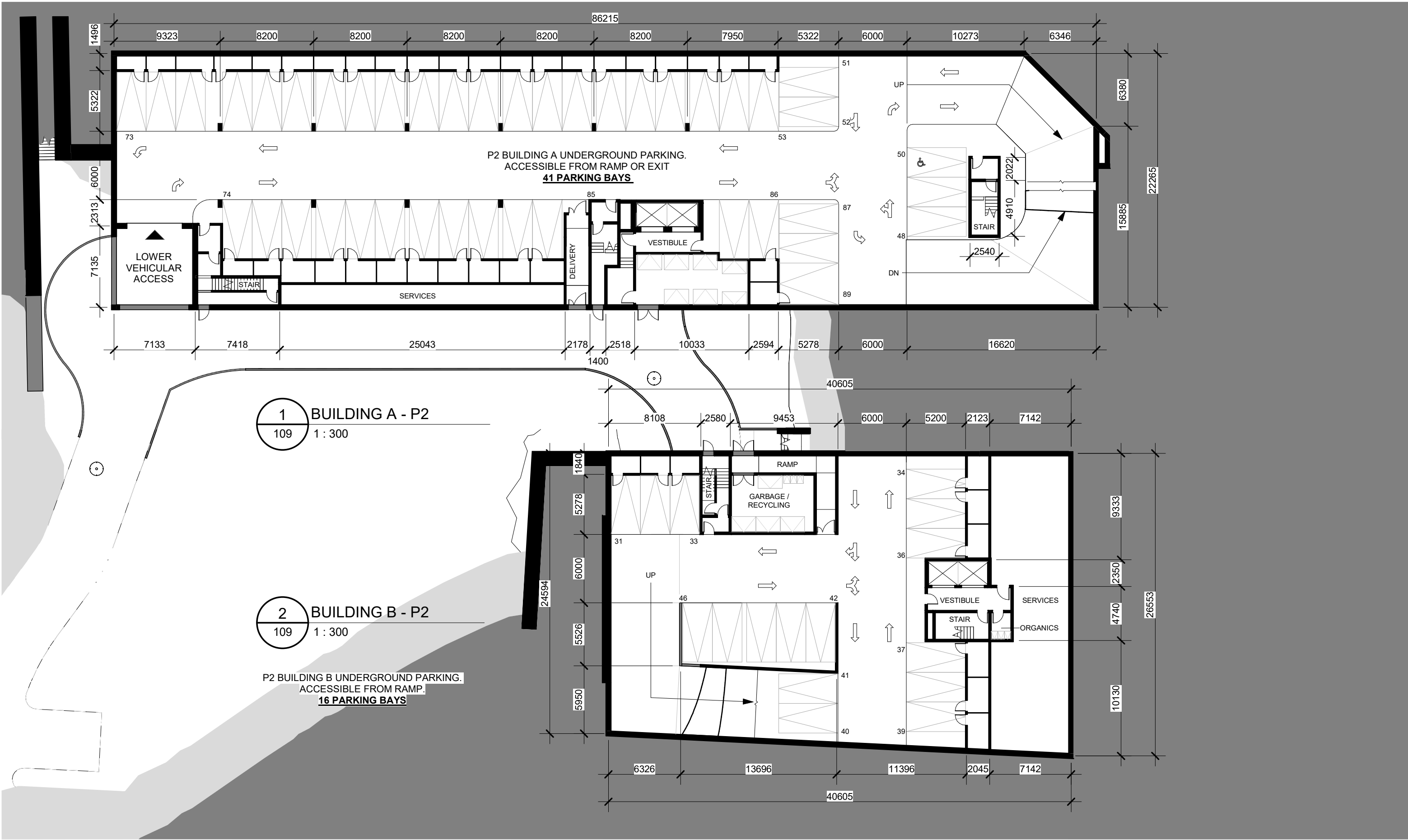



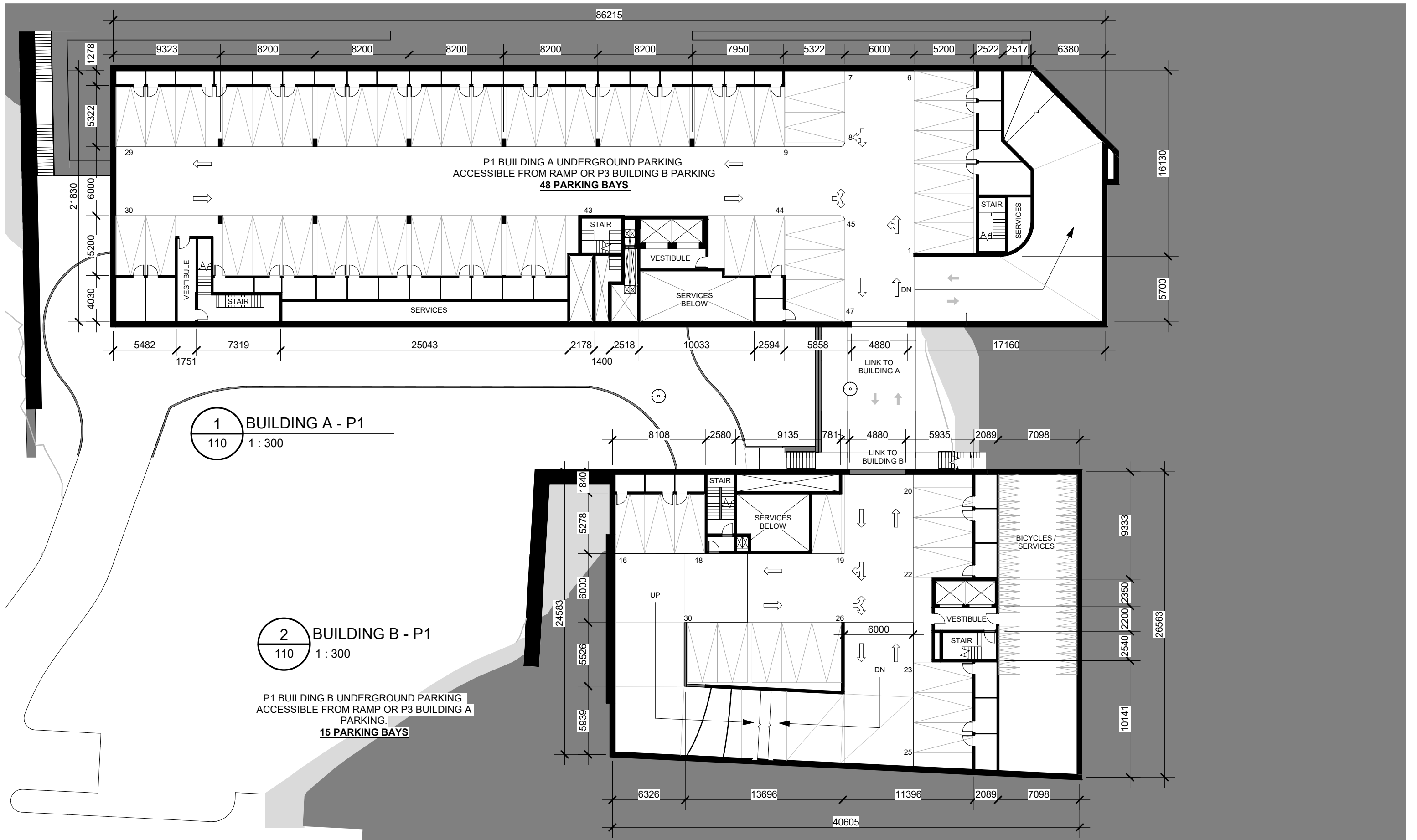



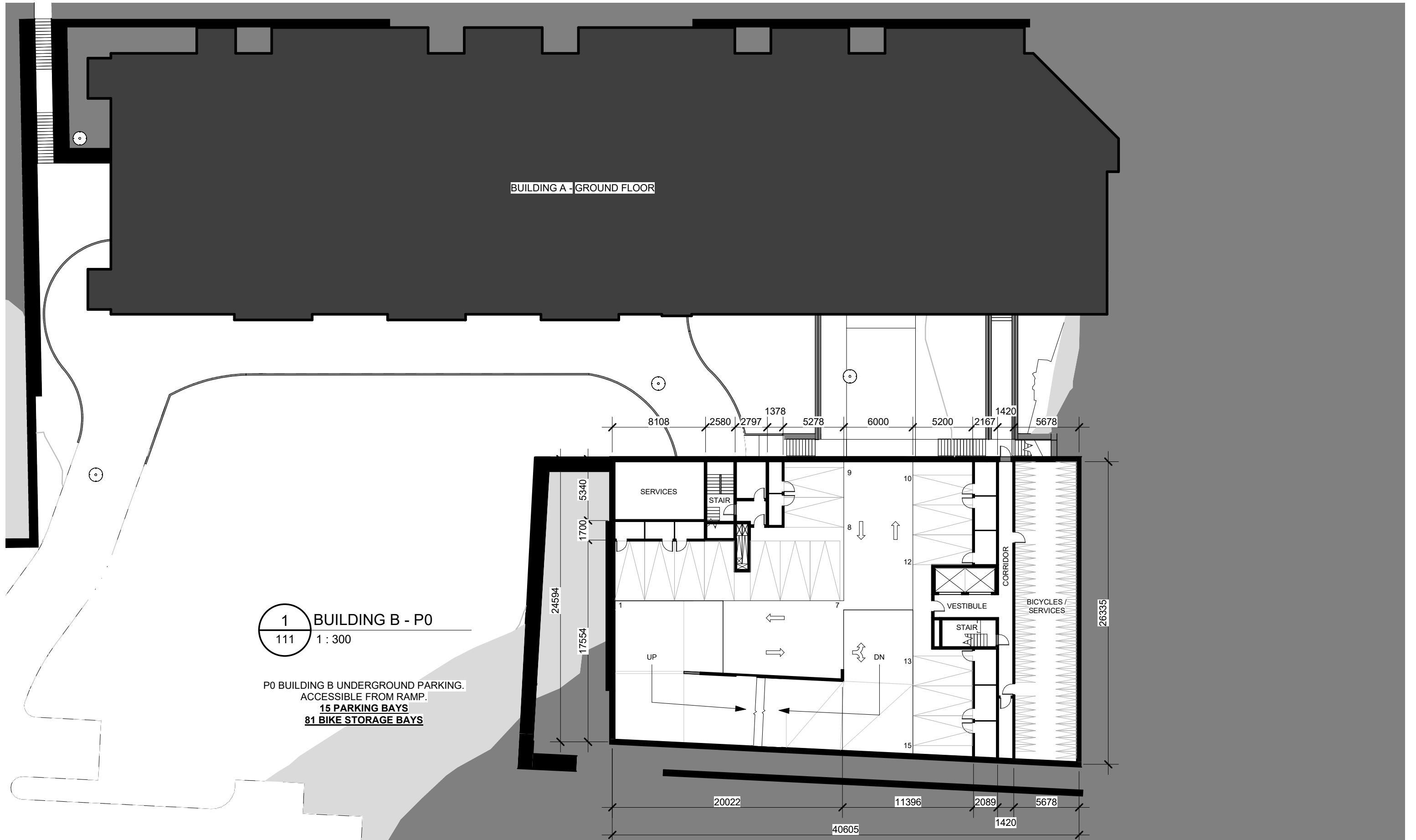



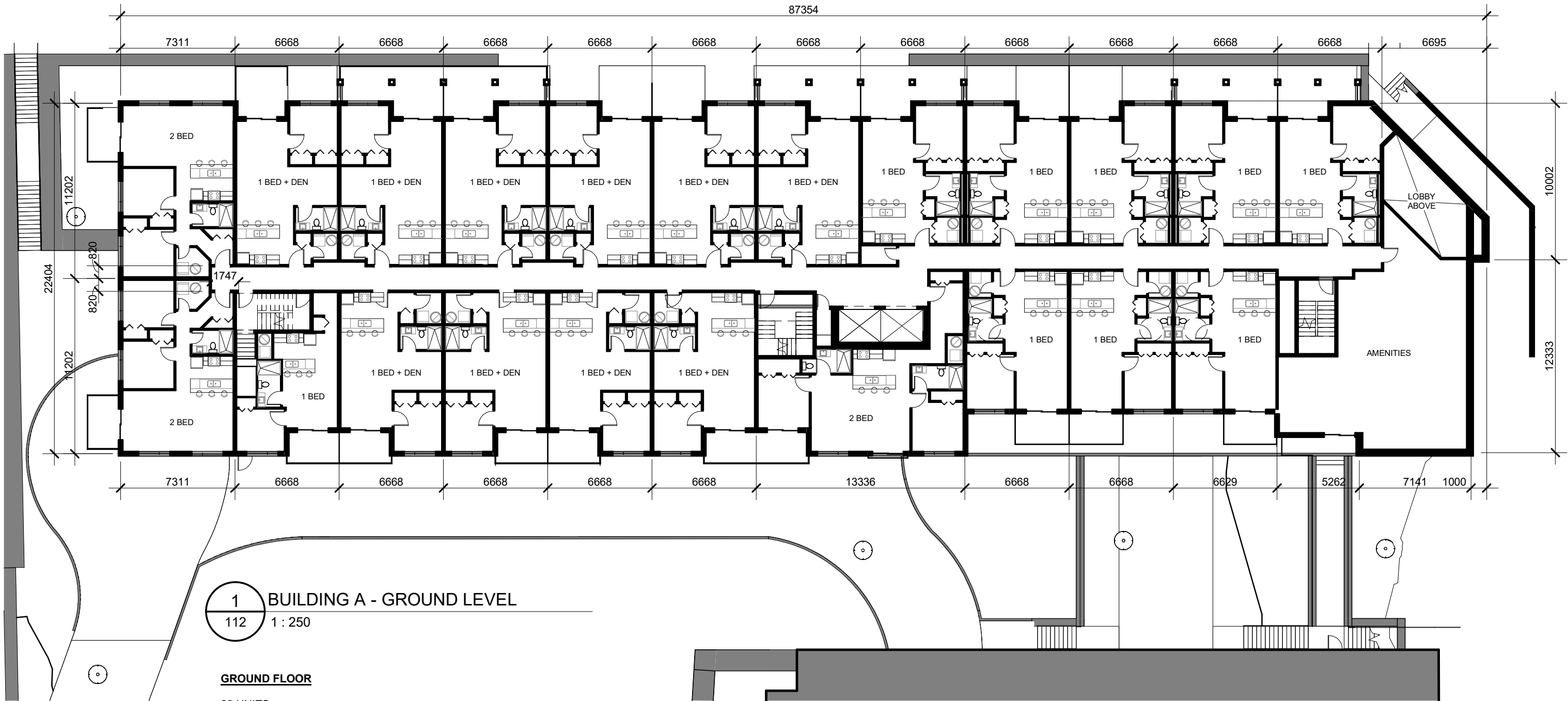

1 BUILDING A - GROUND LEVEL  
112 1 : 250

**GROUND FLOOR**  
22 UNITS:  
9 x ONE BEDROOM  
10 x ONE BEDROOM + DEN  
3 x TWO BEDROOM



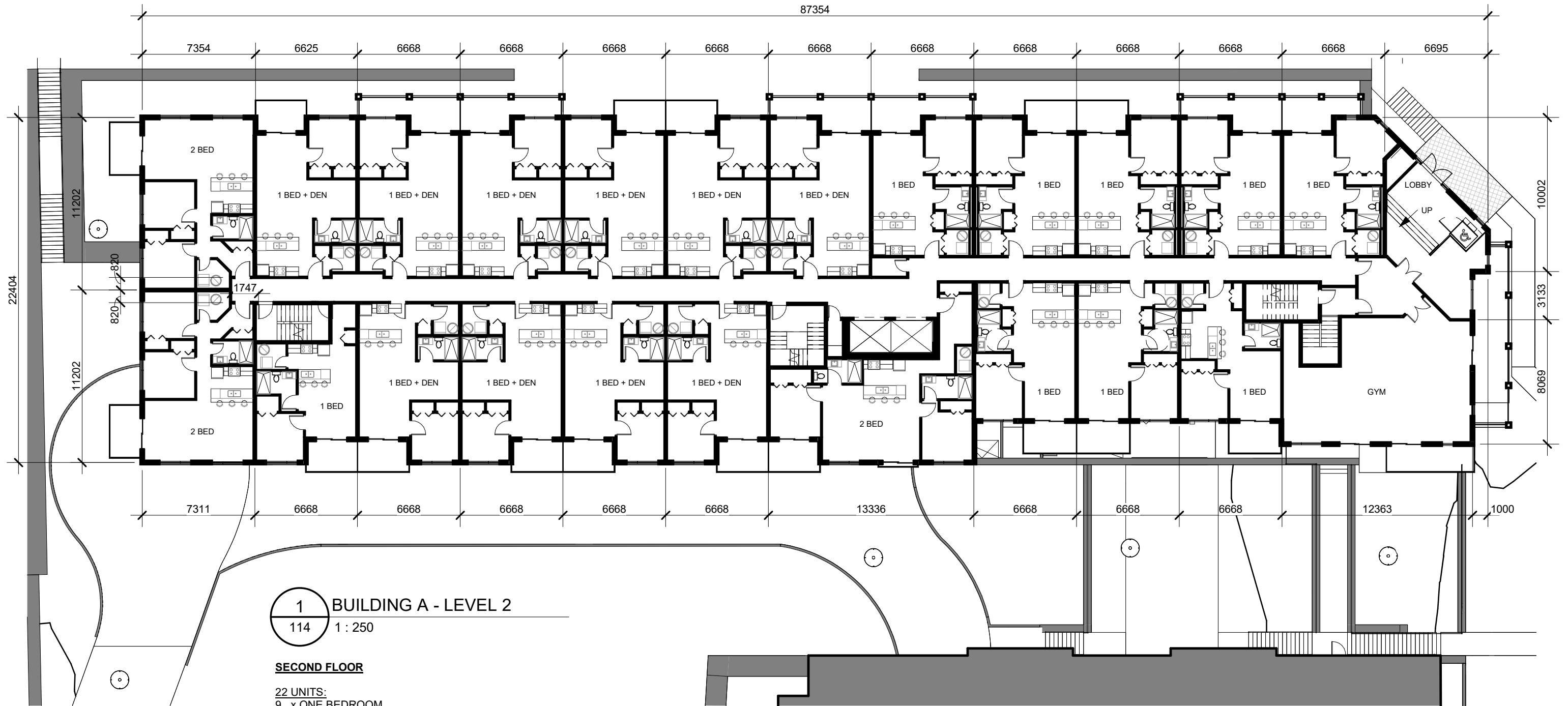

1 BUILDING A - LEVEL 2  
114 1 : 250

**SECOND FLOOR**  
22 UNITS:  
9 x ONE BEDROOM  
10 x ONE BEDROOM + DEN  
3 x TWO BEDROOM



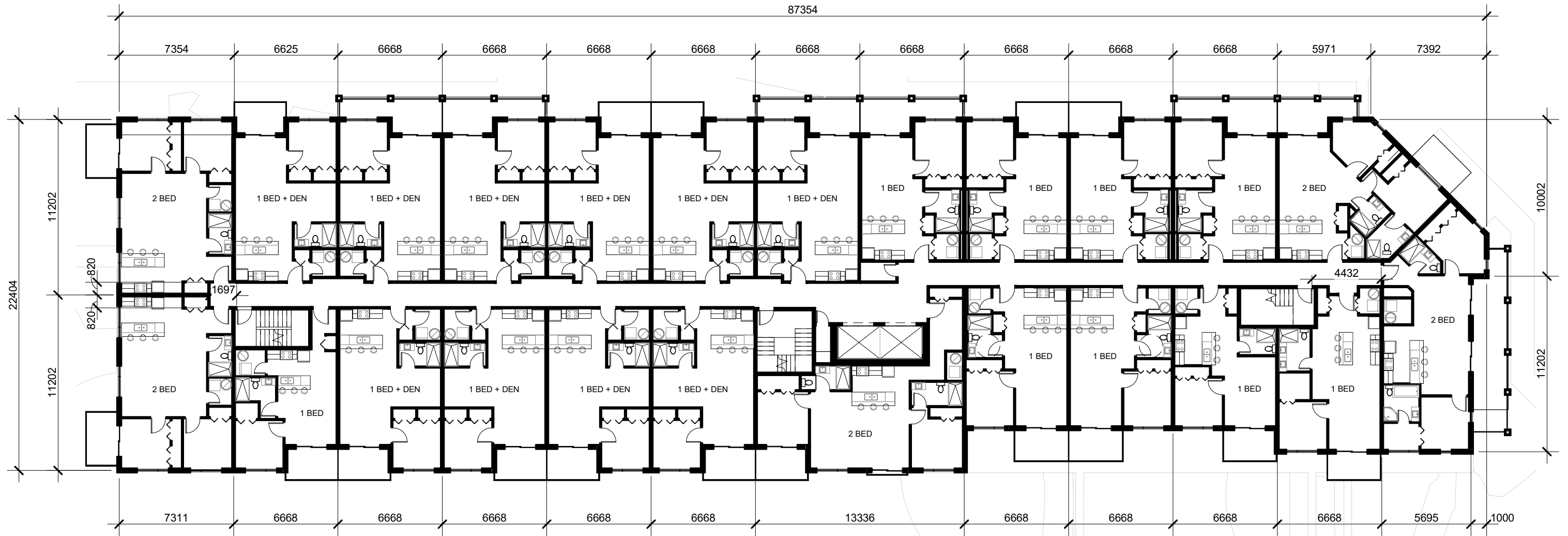

1 BUILDING A - TYPICAL LOWER LEVEL  
116 1 : 250

**TYPICAL LOWER FLOOR**

24 UNITS:  
9 x ONE BEDROOM  
10 x ONE BEDROOM + DEN  
5 x TWO BEDROOM



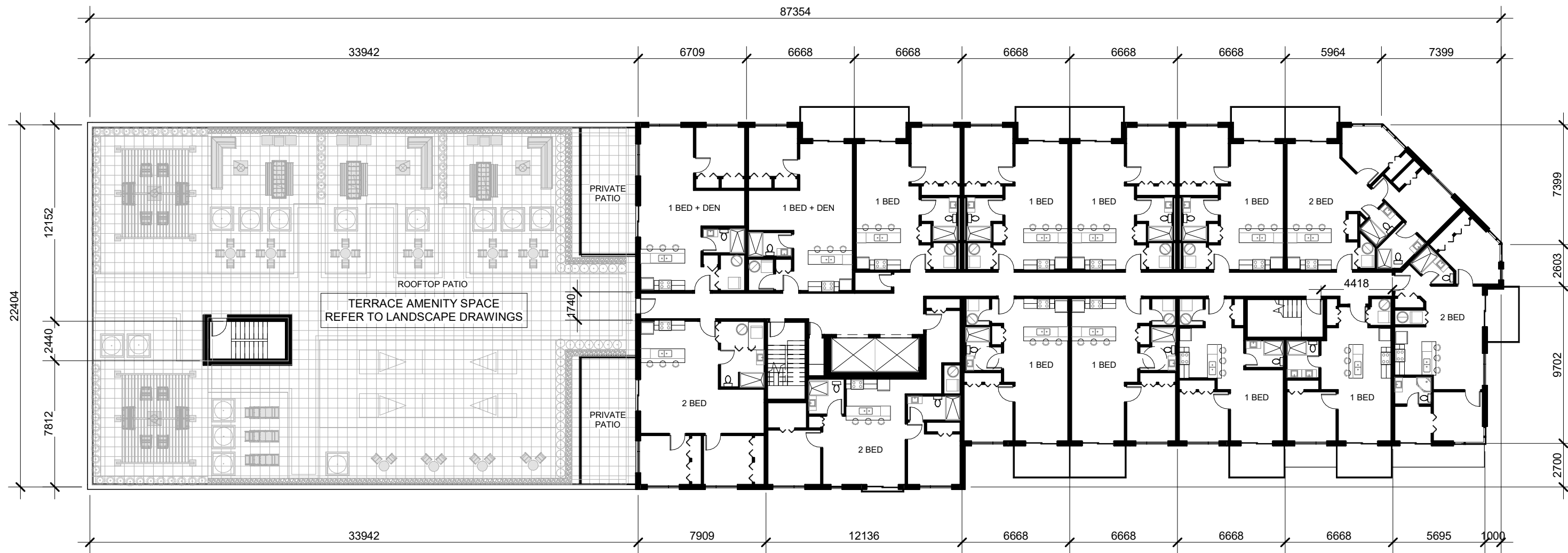

1 BUILDING A - LEVEL 6  
118 1 : 250

**TYPICAL UPPER FLOOR**

- 14 UNITS:  
8 x ONE BEDROOM  
2 x ONE BEDROOM + DEN  
4 x TWO BEDROOM





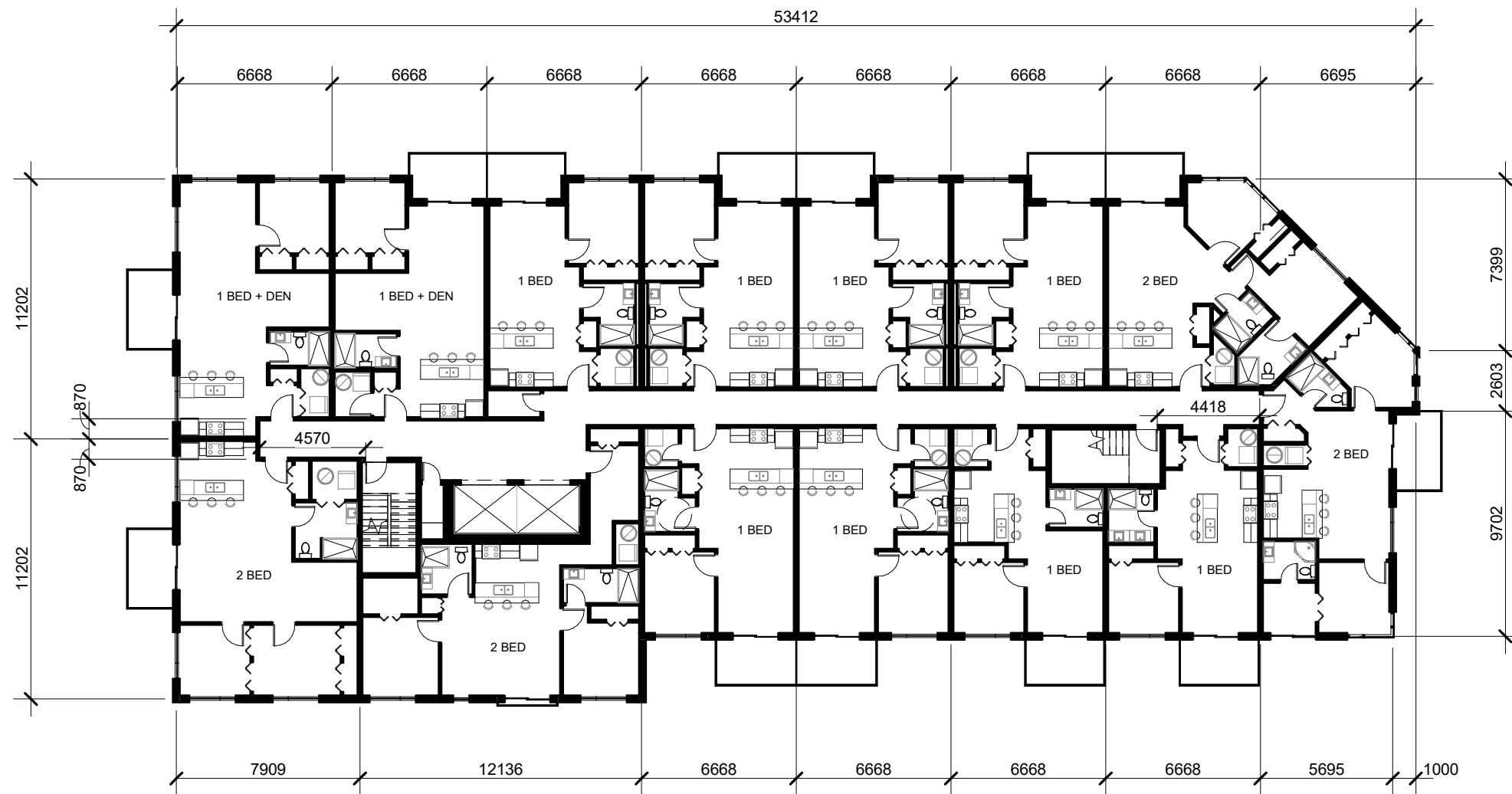

1 BUILDING A - TYPICAL UPPER LEVEL  
119 1 : 250

**TYPICAL UPPER FLOOR**

- 14 UNITS:  
8 x ONE BEDROOM  
2 x ONE BEDROOM + DEN  
4 x TWO BEDROOM





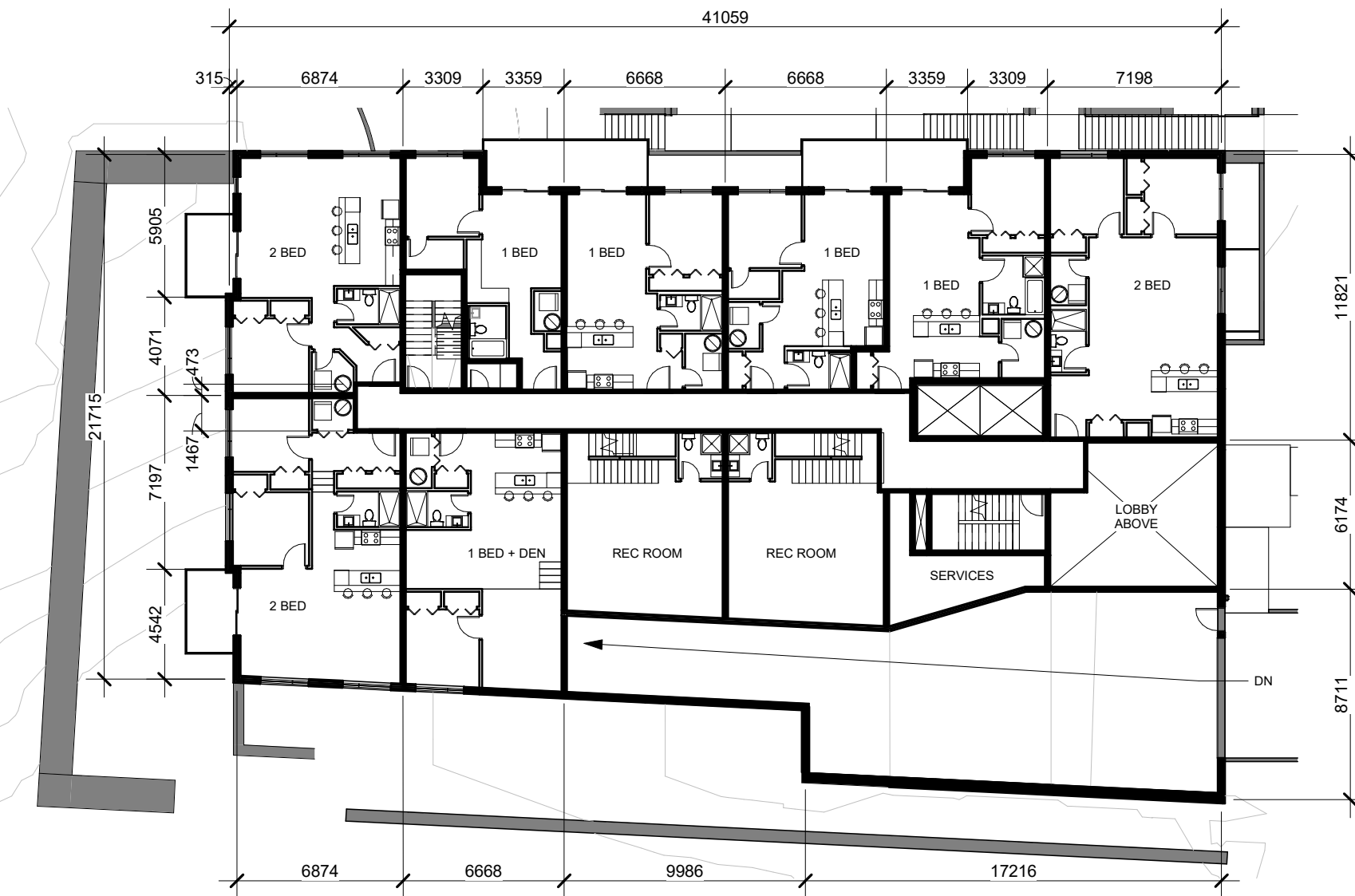

1 BUILDING B - GROUND LEVEL  
113 1 : 250

- GROUND FLOOR**
- 8 UNITS:  
 4 x ONE BEDROOM  
 1 x ONE BEDROOM + DEN  
 3 x TWO BEDROOM



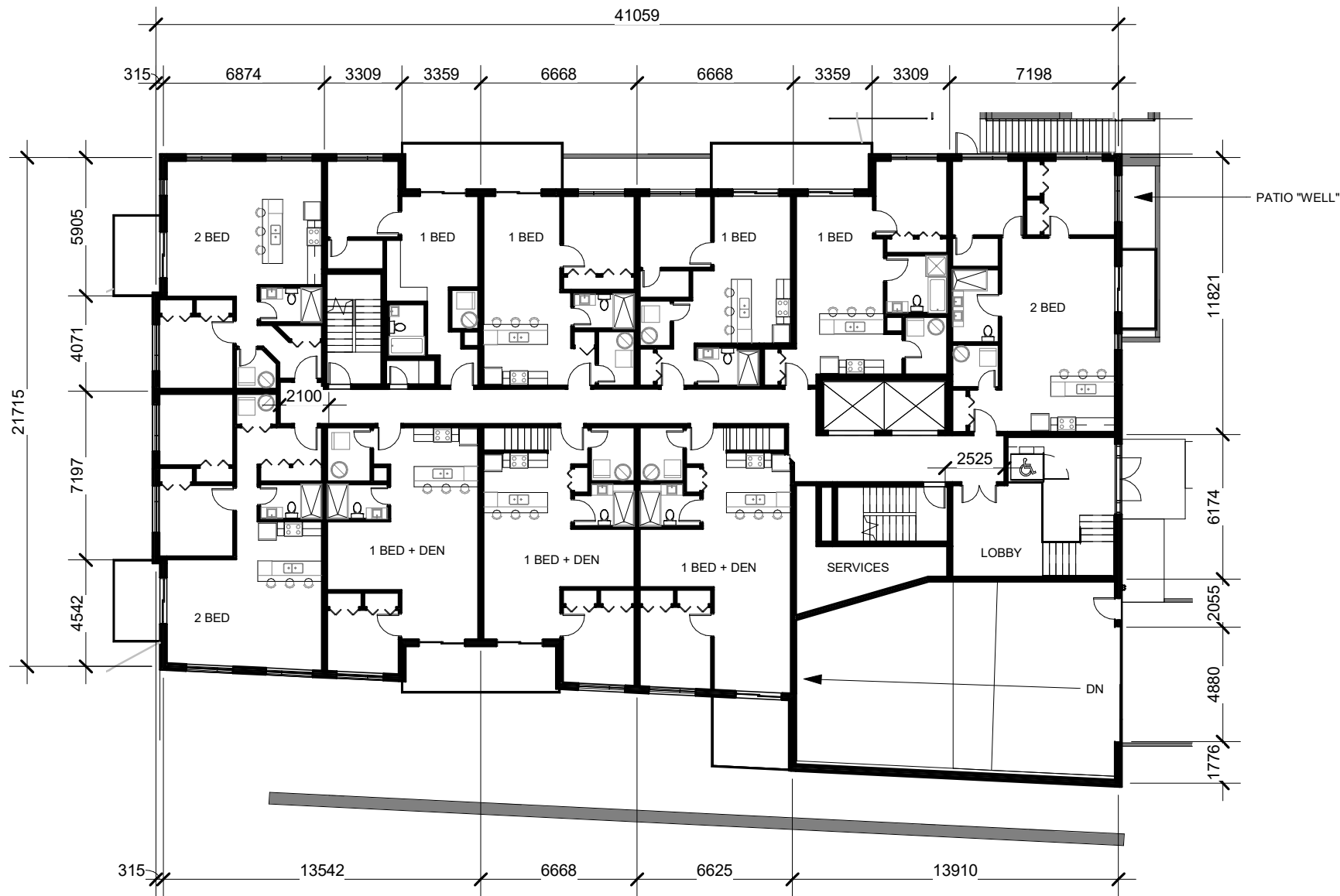

2 BUILDING B - LEVEL 2  
115 1 : 250

**SECOND FLOOR**

- 10 UNITS:  
4 x ONE BEDROOM  
3 x ONE BEDROOM + DEN  
3 x TWO BEDROOM



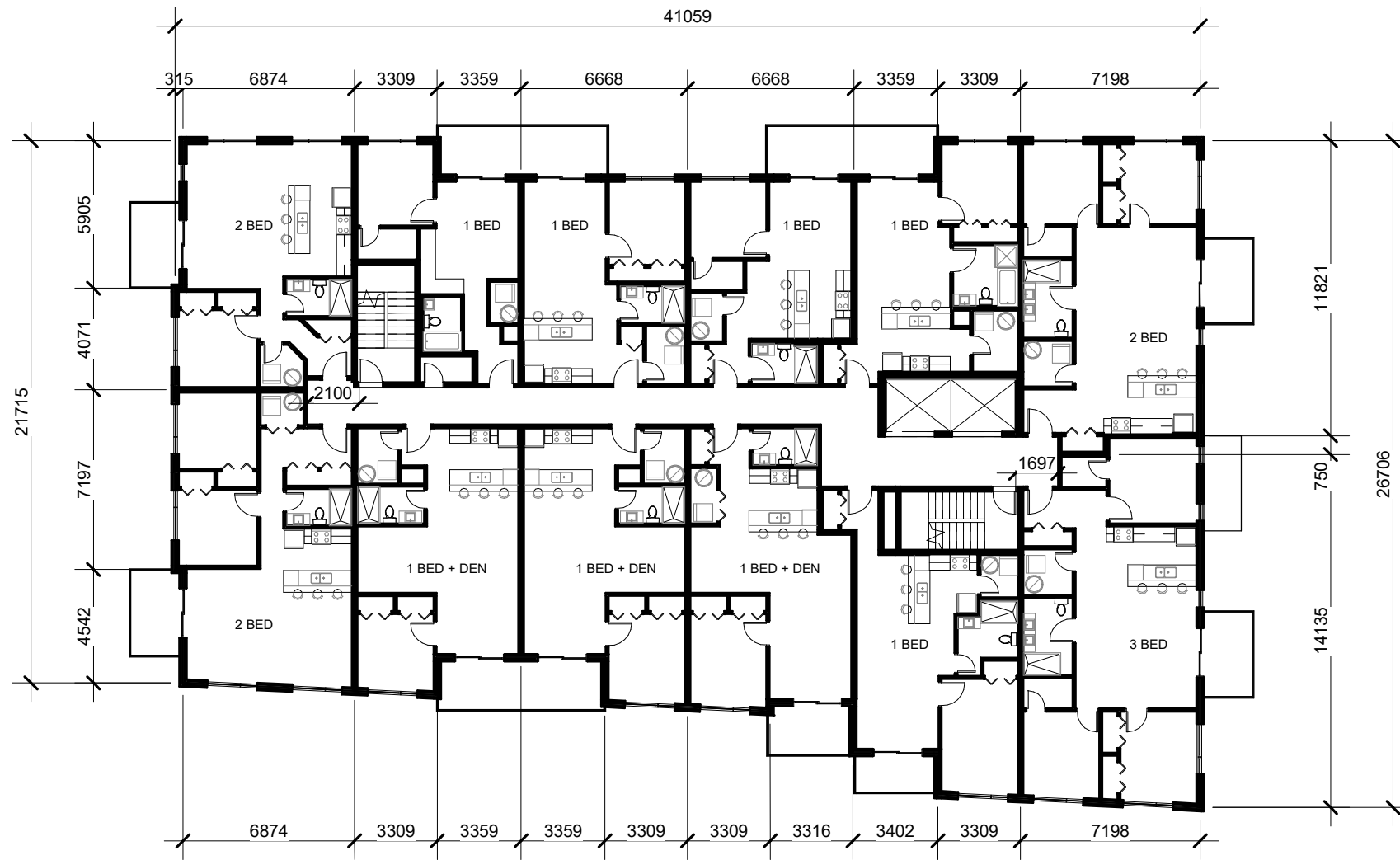

1 BUILDING B - TYPICAL LOWER LEVEL  
117 1 : 250

**TYPICAL LOWER FLOOR**

- 10 UNITS:  
 5 x ONE BEDROOM  
 3 x ONE BEDROOM + DEN  
 3 x TWO BEDROOM  
 1 x THREE BEDROOM



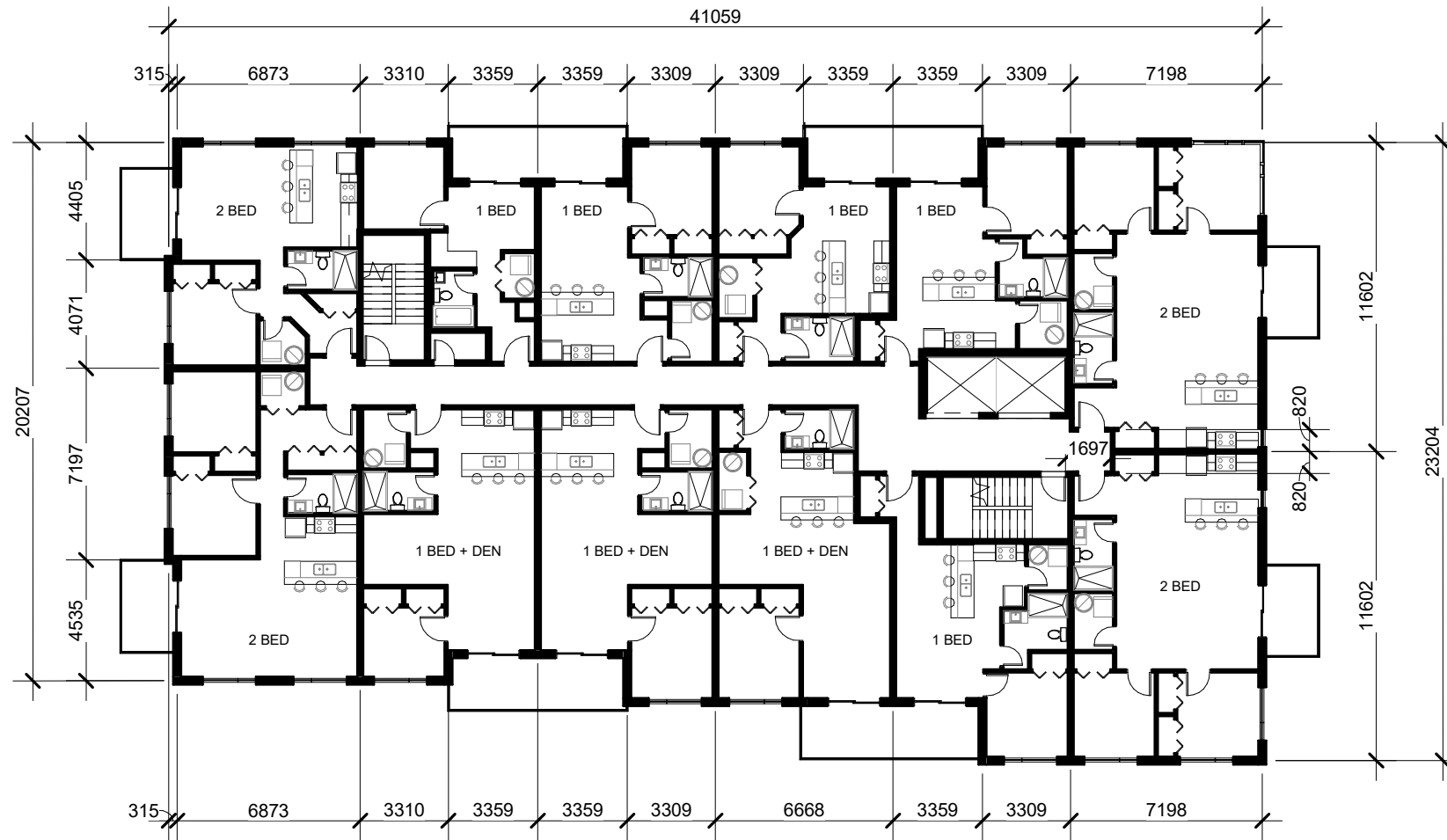

1 BUILDING B - TYPICAL UPPER LEVEL  
120 1 : 250

**TYPICAL UPPER FLOOR**

- 11 UNITS:  
 5 x ONE BEDROOM  
 3 x ONE BEDROOM + DEN  
 4 x TWO BEDROOM





1 BUILDING A - EAST ELEVATION  
300 1 : 300

EXTERIOR WALL MATERIAL				
Tag	Name	Material: Model	Material: Comments	Manufacturer
M1	20030 - AlucoBond Metal Panel - White	PVDF 2	Magnolia	AlucoBond
M2	20030 - AlucoBond Metal Panel - Black	SMP	TBL Black	AlucoBond
M3	20030 - Permacon Masonry - Biege	LEXA STONE	Biege	Permacon



ABOVE SEA LEVEL HEIGHT LIMIT: 105M ASL - R5Z[1415]



1 BUILDING A - WEST ELEVATION  
301 1 : 300

EXTERIOR WALL MATERIAL				
Tag	Name	Material: Model	Material: Comments	Manufacturer
M1	20030 - AlucoBond Metal Panel - White	PVDF 2	Magnolia	AlucoBond
M2	20030 - AlucoBond Metal Panel - Black	SMP	TBL Black	AlucoBond
M3	20030 - Permacon Masonry - Biege	LEXA STONE	Biege	Permacon



ABOVE SEA LEVEL HEIGHT LIMIT: 105M ASL - R5Z[1415]

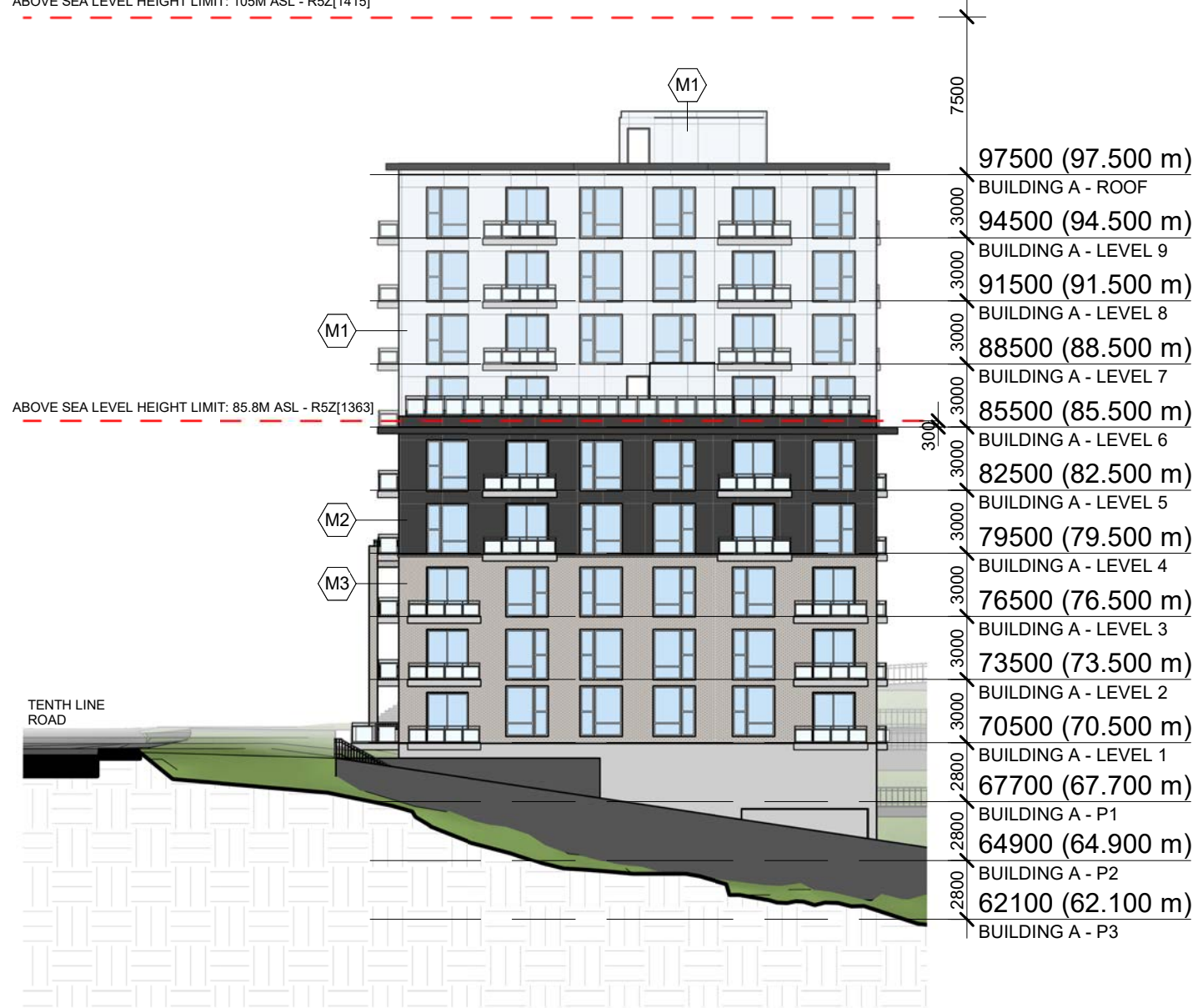

1 BUILDING A - NORTH ELEVATION  
302 1 : 300

ABOVE SEA LEVEL HEIGHT LIMIT: 105M ASL - R5Z[1415]



2 BUILDING A - SOUTH ELEVATION  
302 1 : 300

**EXTERIOR WALL MATERIAL**

Tag	Name	Material: Model	Material: Comments	Manufacturer
M1	20030 - AlucoBond Metal Panel - White	PVDF 2	Magnolia	AlucoBond
M2	20030 - AlucoBond Metal Panel - Black	SMP	TBL Black	AlucoBond
M3	20030 - Permacon Masonry - Biege	LEXA STONE	Biege	Permacon





1 BUILDING B - EAST ELEVATION  
 303 1 : 300



2 BUILDING B - WEST ELEVATION  
 303 1 : 300

EXTERIOR WALL MATERIAL				
Tag	Name	Material: Model	Material: Comments	Manufacturer
M1	20030 - AlucoBond Metal Panel - White	PVDF 2	Magnolia	AlucoBond
M2	20030 - AlucoBond Metal Panel - Black	SMP	TBL Black	AlucoBond
M3	20030 - Permacon Masonry - Biege	LEXA STONE	Biege	Permacon

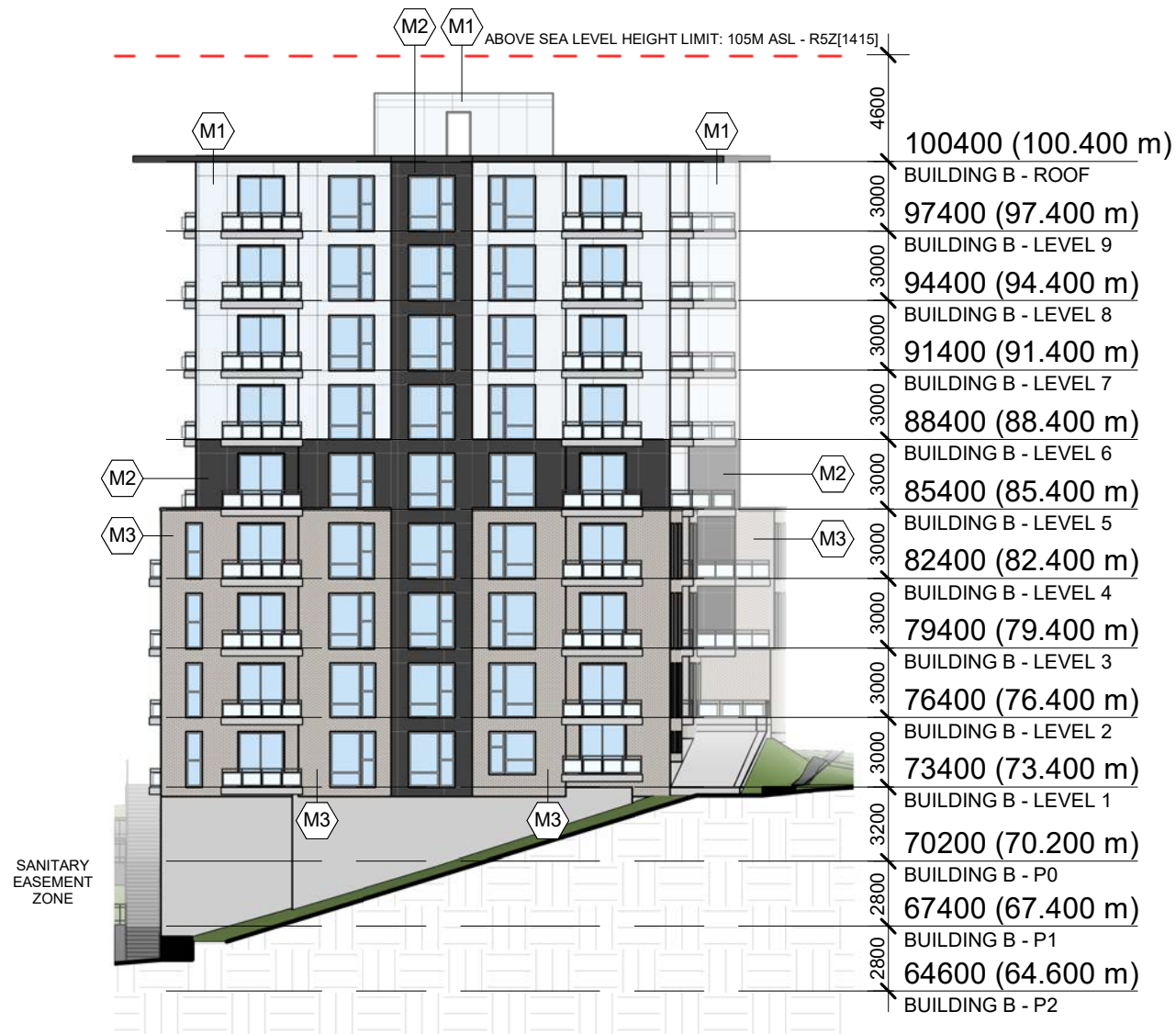

1 BUILDING B - NORTH ELEVATION  
304 1 : 300



2 BUILDING B - SOUTH ELEVATION  
304 1 : 300

EXTERIOR WALL MATERIAL				
Tag	Name	Material: Model	Material: Comments	Manufacturer
M1	20030 - AlucoBond Metal Panel - White	PVDF 2	Magnolia	AlucoBond
M2	20030 - AlucoBond Metal Panel - Black	SMP	TBL Black	AlucoBond
M3	20030 - Permacon Masonry - Biege	LEXA STONE	Biege	Permacon



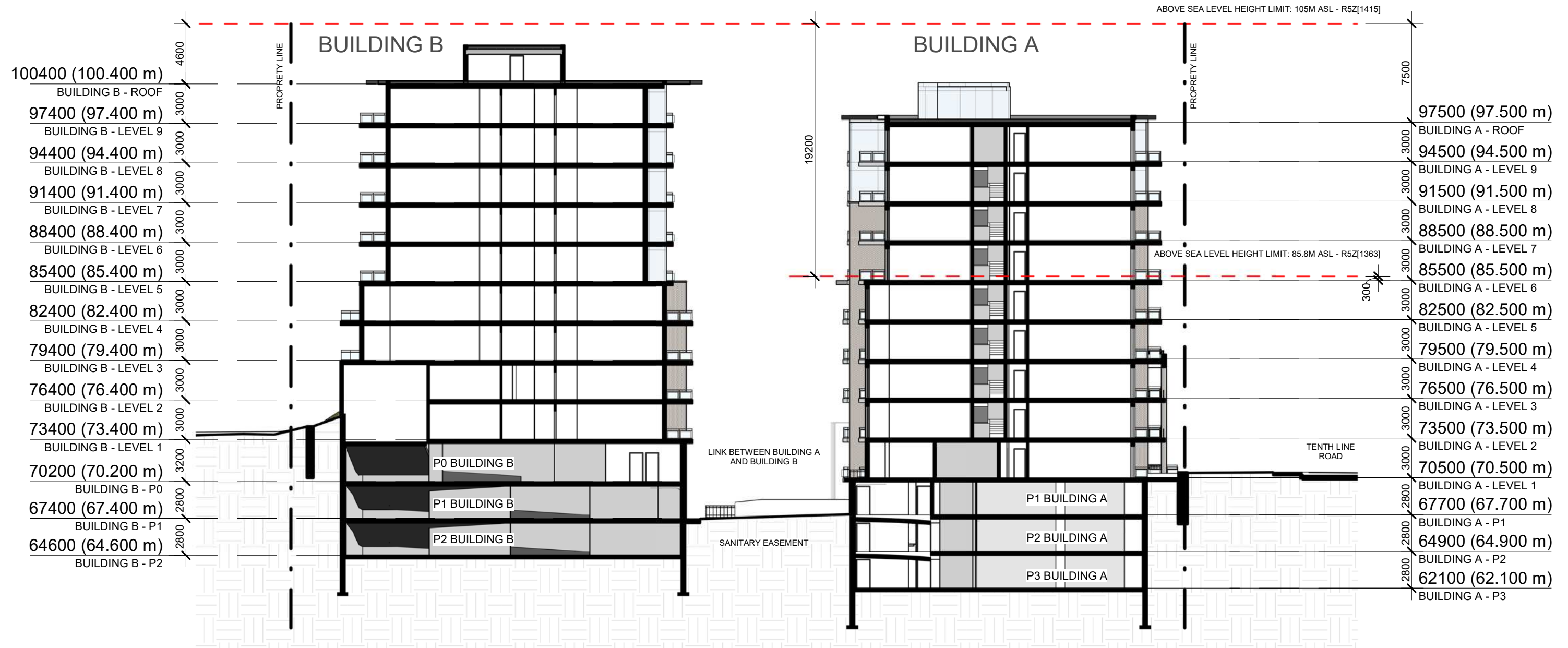

1 TENTHLINE AND HILLSIDE CONDOS  
400 1 : 300

ABOVE SEA LEVEL HEIGHT LIMIT: 105m ASL - R5Z[1415]

ABOVE SEA LEVEL HEIGHT LIMIT: 85.8M ASL - R5Z[1363]

### BUILDING B

PROPERTY LINE

PROPERTY LINE

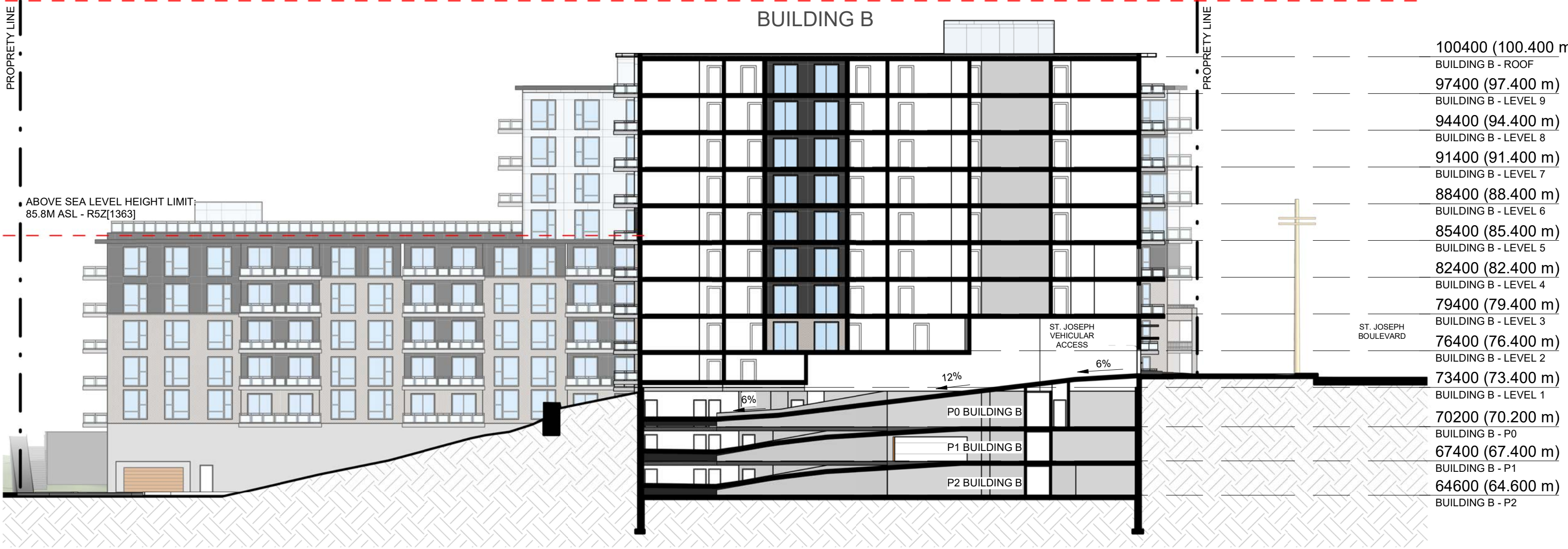

100400 (100.400 m)
BUILDING B - ROOF
97400 (97.400 m)
BUILDING B - LEVEL 9
94400 (94.400 m)
BUILDING B - LEVEL 8
91400 (91.400 m)
BUILDING B - LEVEL 7
88400 (88.400 m)
BUILDING B - LEVEL 6
85400 (85.400 m)
BUILDING B - LEVEL 5
82400 (82.400 m)
BUILDING B - LEVEL 4
79400 (79.400 m)
BUILDING B - LEVEL 3
76400 (76.400 m)
BUILDING B - LEVEL 2
73400 (73.400 m)
BUILDING B - LEVEL 1
70200 (70.200 m)
BUILDING B - P0
67400 (67.400 m)
BUILDING B - P1
64600 (64.600 m)
BUILDING B - P2

ST. JOSEPH VEHICULAR ACCESS

ST. JOSEPH BOULEVARD

1 ST-JOSEPH BOULEVARD  
 402 1 : 300



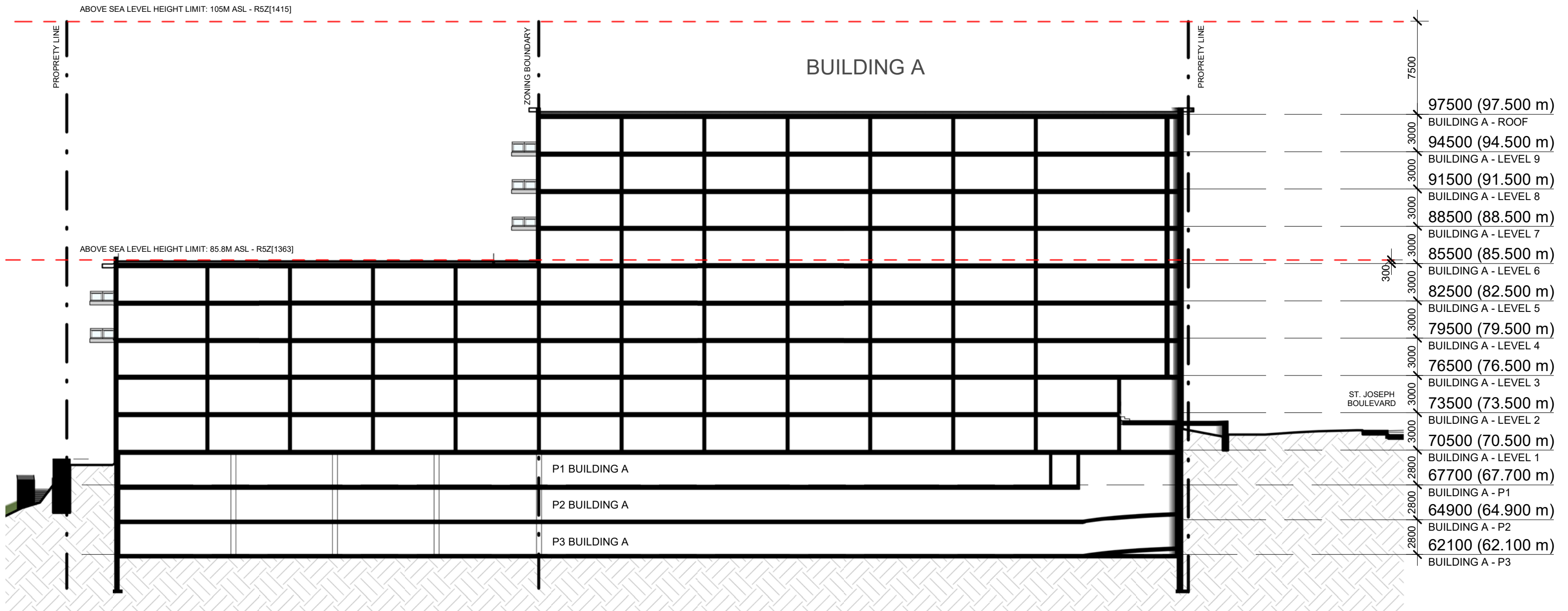

1 CUTTING IN TENTHLINE  
401 1 : 300