

SERVICING & STORMWATER MANAGEMENT REPORT APARTMENT BUILDING – 1940 CARLING AVENUE



Project No.: CP-20-0079

City File No.: D07-12-22-0001

Prepared for:

Domenic Santaguida
domenic.santaguida@vittoriatrattoria.com

Prepared by:

McIntosh Perry Consulting Engineers Ltd.
115 Walgreen Road
Carp, ON K0A 1L0

September 17, 2021

Revision 6: July 7th, 2023

TABLE OF CONTENTS

1.0	PROJECT DESCRIPTION	1
1.1	Purpose	1
1.2	Site Description.....	1
2.0	BACKGROUND STUDIES.....	2
3.0	PRE-CONSULTATION SUMMARY	2
4.0	WATERMAIN	3
4.1	Existing Watermain	3
4.2	Proposed Watermain.....	3
5.0	SANITARY DESIGN	5
5.1	Existing Sanitary Sewer	5
5.2	Proposed Sanitary Sewer	5
6.0	STORM SEWER DESIGN	6
6.1	Existing Storm Sewers.....	6
6.2	Proposed Storm Sewers	6
7.0	PROPOSED STORM WATER MANAGEMENT	7
7.1	Design Criteria and Methodology.....	7
7.2	Runoff Calculations.....	7
7.3	Pre-Development Drainage.....	8
7.4	Post-Development Drainage	8
7.5	Quantity Control	9
7.6	Quality Control	12
8.0	EROSION AND SEDIMENT CONTROL.....	13
8.1	Temporary Measures.....	13
8.2	Permanent Measures.....	13
9.0	SUMMARY.....	14
10.0	RECOMMENDATION.....	15
11.0	STATEMENT OF LIMITATIONS.....	16

LIST OF TABLES

Table 1: Water Demands.....	3
Table 2: Water Pressure at Junctions per Scenario	4
Table 3: Fire Protection Confirmation.....	4
Table 4: Pre-Development Runoff Summary.....	8
Table 5: Post-Development Runoff Summary	9
Table 6: Allowable Release Rate Summary	10
Table 7: Post-Development Restricted Runoff Summary	10
Table 8: Storage Summary	11
Table 9: Roof Drain Drawdown Times	12

APPENDICES

Appendix A: Site Location Plan

Appendix B: City of Ottawa Pre-Consultation Notes

Appendix C: Watermain Calculations

Appendix D: Sanitary Calculations

Appendix E: Pre-Development Drainage Plan

Appendix F: Post-Development Drainage Plan

Appendix G: Stormwater Management Calculations

Appendix H: City of Ottawa Design Checklist

1.0 PROJECT DESCRIPTION

1.1 Purpose

McIntosh Perry (MP) has been retained by Domenic Santaguida to prepare this Servicing and Stormwater Management Report in support of the Site Plan Control process for the proposed Apartment, located at 1940 Carling within the City of Ottawa.

The main purpose of this report is to present a servicing design for the development in accordance with the recommendations and guidelines provided by the City of Ottawa (City), the Rideau Valley Conservation Authority (RVCA), and the Ministry of the Environment, Conservation and Parks (MECP). This report will address the water, sanitary and storm sewer servicing for the development, ensuring that existing and available services will adequately service the proposed development.

This report should be read in conjunction with the following drawings:

- CP-20-0079, C101 – Removals, Site Servicing, Grading and Drainage Plan

1.2 Site Description

The property is located at 1940 Carling Avenue within Ward 7 (Bay). It is described as Plan 290559, Lot 27 and part of Lot 26, City of Ottawa. The land in question covers approximately 0.15 ha and is located near the intersection of Carling Avenue and Maitland Avenue. The development area for the proposed works is approximately 0.15 ha.

See Site Location Plan in Appendix 'A' for more details.

The existing site is currently developed as a two-storey detached dwelling and includes an asphalt driveway. The existing site has sanitary and water services however, there are no storm services. The existing services will be removed and replaced for the proposed development.

The proposed development consists of a 595 m² ground floor area, seven storey apartment building. Parking and drive aisles will be provided throughout the site along with landscaping. There will be one site access for the development located along Carling Avenue.

2.0 BACKGROUND STUDIES

Background studies that have been completed for the proposed site include City of Ottawa as-built drawings, a topographical survey, and a geotechnical report.

As-built drawings of existing services within the vicinity of the proposed site were reviewed in order to determine accurate servicing and stormwater management schemes for the site.

A topographic survey of the site was completed by Farley, Smith & Denis Surveying LTD.

The following reports have previously been completed and are available under separate cover:

- Geotechnical Investigation completed by Kollaard Associates, dated April 30, 2021.

3.0 PRE-CONSULTATION SUMMARY

A pre-consultation meeting was conducted on February 13, 2020 regarding the proposed site. Specific design parameters to be incorporated within this design include the following:

- Pre-development and post-development flows shall be calculated using a time of concentration (Tc) of 20 minutes or calculated with a minimum TC of 10 minutes.
- Control 2 through 100-year post-development flows to the 2-year pre-development flows with a combined C value to a maximum of 0.50.

The notes from the City of Ottawa can be found in Appendix 'B'.

4.0 WATERMAIN

4.1 Existing Watermain

There are two existing 150mm diameter ductile iron watermains within Carling Avenue which are located at the north and south laneways. The watermains service the adjacent properties along Carling as well as the fire hydrants along the north and south sides of Carling Avenue. There is also a 600mm diameter watermain within the center of Carling Avenue that feeds both the 150mm diameter mains.

4.2 Proposed Watermain

Two new 150mm diameter PVC water services are proposed to service the site complete with a water valve located at the property line and will be connected to the existing southernmost 150 mm diameter watermain within Carling Avenue. An isolation valve will be installed between the two services to comply with technical bulletin 2021-03. The water services are designed to have a minimum of 2.4 m cover.

The Fire Underwriters Survey 2020 (FUS) method was utilized to determine the required fire flow for the site. The 'C' factor (type of construction) for the FUS calculation was determined to be 0.8 (Non-Combustible Construction) based on coordination with the architect. The total floor area ('A' value) for the FUS calculation was determined to be 3,720.8 m². The results of the calculations yielded a required fire flow of 8,000 L/min. The detailed calculations for the FUS and OBC can be found in Appendix 'C'.

The water demands for the proposed building have been calculated to adhere to the Ottawa Design Guidelines – Water Distribution manual and can be found in Appendix 'C'. The results have been summarized below:

Table 1: Water Demands

Site Area	0.15 ha
Residential	280 L/c/day
Average Day Demand (L/s)	0.30
Maximum Daily Demand (L/s)	0.76
Peak Hourly Demand (L/s)	1.68
OBC Fire Flow Requirement (L/s)	150.00
FUS Fire Flow Requirement (L/s)	133.33
Max Day + Fire Flow (FUS) (L/s)	135.01

The initial fire protection calculations were based on the 1999 FUS method and indicated a required fire flow of 13,000 L/min. Revisions to the FUS and site plan changes have resulted in a reduction in the required fire flow to 8,000 L/min.

Boundary conditions have been provided by the City of Ottawa and are available in Appendix 'C'. The subject site is located in pressure zone 1W. A water model was completed using Bentley's WaterCAD based on the boundary conditions. The results determined that the proposed 150mm water service can adequately service the proposed development and provide sufficient fire flow since Hydrant H-2 produced available fire flows of 4,451 L/min and Hydrant H-3 produced a flow of 7,707 L/min under fire flow conditions. A multi-hydrant analysis was also completed by City Staff. The multi-hydrant analysis indicated the existing hydrants can provide sufficient capacity for the fire demand of 133.3 L/s. The results of the water model and correspondence with the City regarding the multi-hydrant analysis can be found in Appendix 'C' of this report.

Prior to connecting to the municipal water distribution system, it is essential to determine whether the system has adequate capacity and that the overall impact to the existing system is minimal. A WaterCAD model was generated to determine the capacity, pressure and size of pipes required to service the proposed site. Three (3) different scenarios were analyzed within the model, namely average day, maximum day + fire flow and peak hourly demands.

When modelling the proposed water distribution system for 1940 Carling Avenue, it was necessary to determine which scenario produced a greater demand: the maximum day + fire flow or peak hourly. It was concluded that the maximum day + fire flow scenario would govern the design process, since it produced the higher demand. A layout of the WaterCAD model has been attached in Appendix 'C'.

The normal operating pressure range is anticipated to be 287 kPa to 345 kPa and will not be less than 275 kPa (40 psi) or exceed 689 kPa (100 psi). The proposed watermain will meet the minimum required 20 psi (140 kPa) at the ground level under maximum day demand and fire flow conditions.

Table 2: Water Pressure at Junctions per Scenario

Junction	Average Day (psi)	Peak Hourly (psi)
J-1	49.97	41.59

To confirm the adequacy of fire flow to protect the proposed development, public and private fire hydrants within 150 m of the proposed building were analysed per City of Ottawa ISTB 2018-02 Appendix I Table 1. The results are demonstrated below.

Table 3: Fire Protection Confirmation

Building	Fire Flow Demand (L/min.)	Fire Hydrant(s) within 75m	Fire Hydrant(s) within 150m	Combined Fire Flow (L/min.)
Ste Address	8,000	2	0	10,151

5.0 SANITARY DESIGN

5.1 Existing Sanitary Sewer

There are two existing 225mm diameter concrete sanitary sewers within Carling Avenue located under the north and south laneways respectively. The existing sanitary service is to be cut and capped at the property line.

5.2 Proposed Sanitary Sewer

A new 250 mm diameter gravity sanitary service will be connected to the existing sanitary maintenance hole within Carling Avenue. The sanitary service will be complete with a maintenance manhole (MH1A) which will be installed just inside the property line as per the City of Ottawa – Sewer Design Guidelines, October 2012, Clause 4.4.4.7 and City of Ottawa Sewer-Use By-Law 2003-514 (14).

The subject site is a proposed apartment building. The total ground floor area of the building is 595 m². The peak design flows for the proposed building were calculated using criteria from the City of Ottawa – Sewer Design Guidelines, October 2012. The proposed site development area (0.15ha) will generate a flow of 1.18 L/s.

The proposed 250 mm diameter gravity sanitary sewers will be installed throughout the subject property with a minimum full flow target velocity (cleansing velocity) of 0.6 m/s and a full flow velocity of not more than 3.0 m/s. Design parameters for the site include an infiltration rate of 0.05 l/s/ha.

The proposed service for the site will be connected to existing sanitary maintenance hole within Carling Avenue and although the sanitary flow is slightly higher for the proposed development, it is anticipated that there will be no issues with capacity constraints within the proposed lateral or within the existing sanitary main within Carling Avenue.

See Sanitary Sewer Design Sheet in Appendix 'D' of this report for more details.

6.0 STORM SEWER DESIGN

6.1 Existing Storm Sewers

There is an existing 300mm diameter concrete storm sewer within Carling Avenue. The existing storm service will be cut and capped at the property line.

6.2 Proposed Storm Sewers

Two new storm services will be extended from the existing 300mm diameter storm sewer within Carling Avenue. The new pipes will collect storm flows from the roof and foundation, restricting runoff prior to leaving the site. Captured roof runoff will be restricted and the required storage for the subject property will be provided on the roof.

Runoff from the rear yard landscaped area will be collected by three landscaping catchbasins and directed to the proposed 250 mm diameter storm service.

The storm services will be sized for the 2-year flow without any restriction. A storm sewer design sheet was created using the rational method and City of Ottawa 2-year storm event. Storm flows will be controlled by roof drains to limit flows to the specified allowable release rate.

The storm design sheet calculates the proper sizing of the storm pipes within the development. Drainage area information, along with respective pipe slopes and other necessary information was utilized to evaluate the performance of the storm sewer network. The time of concentration calculated for the storm sewer system is based on a 10-minute inlet time at the uppermost sewer run. Within the design sheet, pipe capacities and associated full flow velocities have been calculated. The design flow (peak flow) was checked against the theoretical capacity to ensure that each storm sewer pipe can convey the 2-year unrestricted flow.

See CP-20-0079 - POST and Storm Sewer Design Sheet in Appendix 'F' of this report for more details. The Stormwater Management design for the subject property will be outlined in Section 6.0.

7.0 PROPOSED STORMWATER MANAGEMENT

7.1 Design Criteria and Methodology

Stormwater management for the proposed site will be maintained through positive drainage away from the proposed building and into a new underground storm sewer system. The storm system will capture roof runoff, restrict it, provide the necessary storage, and release it to the existing 300mm storm sewer within Carling Avenue. The emergency roof scupper will be provided to ensure ponding does not exceed the proposed volume. The quantitative and qualitative properties of the storm runoff for both the pre & post development flows are further detailed below. Stormwater Best Management Practices (SWM BMP's) will be implemented at the "Lot level", "Conveyance" and "End of Pipe" locations. These concepts will be explained further in Section 7.6.

In summary, the following design criteria have been employed in developing the stormwater management design for the site as directed by the RVCA and City:

Quality Control

- The Rideau Valley Conservation Authority (RVCA) has been contacted regarding quality control for the development. Quality controls are not anticipated to be required based on the distance to the outlet and the site runoff being clean roof water.

Quantity Control

- Post-development 2/5-year flow is to be restricted to match the 2-year pre-development flow with a maximum C value of 0.50.

7.2 Runoff Calculations

Runoff calculations presented in this report are derived using the Rational Method, given as:

$$Q = 2.78CIA \text{ (L/s)}$$

Where	C	= Runoff coefficient
	I	= Rainfall intensity in mm/hr (City of Ottawa IDF curves)
	A	= Drainage area in hectares

It is recognized that the Rational Method tends to overestimate runoff rates. As a result, the conservative calculation of runoff ensures that any SWM facility sized using this method is expected to function as intended.

The following coefficients were used to develop an average C for each area:

Roofs/ Concrete/ Asphalt	0.90
Gravel	0.60
Undeveloped and Grass	0.20

As per the City of Ottawa - Sewer Design Guidelines, the 5-year balanced 'C' value must be increased by 25% for a 100-year storm event to a maximum of 1.0.

As per the pre-consultation meeting with the City of Ottawa the time of concentration (Tc) used for pre and post-development shall be calculated and no less than 10 minutes.

7.3 Pre-Development Drainage

The existing site drainage limits are demonstrated on the Pre-Development Drainage Area Plan. A summary of the Pre-Development Runoff Calculations can be found below.

Table 4: Pre-Development Runoff Summary

Drainage Area	Area (ha)	Runoff Coefficient (2/5-Year)	Runoff Coefficient (100-Year)	2-year Peak Flow (L/s)	5-year Peak Flow (L/s)	100-year Peak Flow (L/s)
A1	0.145	0.39	0.45	11.98	16.26	32.43
Total	0.145			11.98	16.26	32.43

See CP-20-0079 - PRE in Appendix 'E' and Appendix 'G' for calculations.

7.4 Post-Development Drainage

The proposed site drainage limits are demonstrated on the Post-Development Drainage Area Plan. See CP-20-0079 - POST in Appendix 'F' of this report for more details. A summary of the Post-Development Runoff Calculations can be found below.

Table 5: Post-Development Runoff Summary

Drainage Area	Area (ha)	Runoff Coefficient (2/5-Year)	Runoff Coefficient (100-Year)	2-year Peak Flow (L/s)	5-year Peak Flow (L/s)	100-year Peak Flow (L/s)
B1A	0.006	0.90	1.00	1.20	1.63	3.10
B2A	0.006	0.90	1.00	1.17	1.59	3.02
B2A	0.009	0.90	1.00	1.77	2.40	4.57
B2B	0.009	0.90	1.00	1.71	2.31	4.40
B2C	0.006	0.90	1.00	1.13	1.54	2.93
B2D	0.007	0.90	1.00	1.36	1.84	3.50
B3A	0.011	0.75	0.83	1.70	2.30	4.42
B3B	0.011	0.81	0.90	1.93	2.61	4.99
B3C	0.011	0.74	0.84	1.75	2.37	4.54
B4A	0.002	0.90	1.00	0.46	0.63	1.19
B4B	0.002	0.90	1.00	0.48	0.65	1.24
B5A	0.002	0.90	1.00	0.36	0.49	0.94
B5B	0.002	0.90	1.00	0.36	0.49	0.94
B6	0.061	0.40	0.46	5.14	6.97	13.87
Total	0.145			20.50	27.81	53.64

See Appendix 'G' for calculations. Runoff for areas B1-B5 will be restricted before outletting to the existing storm system within Carling Avenue. The flow will be controlled within the roof drains for areas B1-B5. Runoff for area B6 will be unrestricted and drain to the Carling Avenue right of way. Runoff from area B6 will be unrestricted. A portion of area B6 will be surface drain to the Carling Avenue right of way, while the remainder will be collected and conveyed by three landscaping catchbasins to the proposed 250 mm diameter storm service.

7.5 Quantity Control

After discussing the stormwater management criteria for the site with City staff, the total post-development runoff for the 2 through 5-year storms has been restricted to match the 2-year pre-development flow rate with a maximum combined C value of 0.50. For the 100-year event, the post-development flow will be permitted to exceed the 2-year pre-development flow (See Appendix 'B' for pre-consultation notes). These values create the following allowable release rate and storage volumes for the development site.

Table 6: Allowable Release Rate Summary

Drainage Area	Area (ha)	Runoff Coefficient	Required Restricted Flow * 2-Year* (L/s)
A1	0.145	0.39	11.98

See Appendix 'G' for calculations.

Reducing site flows will be achieved using flow restrictions and will create the need for onsite storage. Runoff from area B1 through B5 will be restricted as shown in the table below.

Table 7: Post-Development Restricted Runoff Summary

Drainage Area	Post Development Unrestricted Flow (L/s)			Post Development Restricted Flow (L/s)			
	2-Year	5-Year	100-Year	2-Year	5-Year	100-Year	
B1A	1.20	1.63	3.10	0.32	0.32	0.32	Restricted - Roof Drains
B2A	1.17	1.59	3.02	0.32	0.32	0.32	
B2A	1.77	2.40	4.57	0.32	0.32	0.32	
B2B	1.71	2.31	4.40	0.32	0.32	0.32	
B2C	1.13	1.54	2.93	0.32	0.32	0.32	
B2D	1.36	1.84	3.50	0.32	0.32	0.32	
B3A	1.70	2.30	4.42	0.32	0.32	0.32	
B3B	1.93	2.61	4.99	0.32	0.32	0.32	
B3C	1.75	2.37	4.54	0.32	0.32	0.32	
B4A	0.46	0.63	1.19	0.32	0.32	0.32	
B4B	0.48	0.65	1.24	0.32	0.32	0.32	
B5A	0.36	0.49	0.94	0.25	0.32	0.32	
B5B	0.36	0.49	0.94	0.25	0.32	0.32	
B6	5.14	6.97	13.87	5.14	6.97	13.87	Unrestricted
Total	20.50	27.81	53.64	9.11	11.07	17.97	

See Appendix 'G' for calculations.

Runoff from Areas B1 through B5 will be restricted through 13 roof drains before discharging to the new storm service. The total flow leaving the roof will be 3.97 L/s, 4.10 L/s and 4.10 L/s during the 2, 5 and 100-year storm events, respectively. This will result in ponding depths of 25mm-105mm. All storage required for this area will

be located on the proposed roof, and emergency roof scuppers will be installed to ensure ponding does not exceed the proposed ponding limits.

Runoff from area B6 will be unrestricted. A portion of area B6 will be surface drain to the Carling Avenue right of way, while the remainder will be collected and conveyed by three landscaping catchbasins to the proposed 250 mm diameter storm service.

Table 8: Storage Summary

Drainage Area	Depth of Ponding (m)	Storage Required (m ³)	Storage Available (m ³)	Depth of Ponding (m)	Storage Required (m ³)	Storage Available (m ³)	Depth of Ponding (m)	Storage Required (m ³)	Storage Available (m ³)
	2-Year			5-Year			100-Year		
B1A	0.045	0.60	0.61	0.055	0.95	1.03	0.085	2.39	2.59
B2A	0.045	0.57	0.60	0.055	0.92	1.01	0.080	2.30	2.30
B2A	0.055	1.09	1.20	0.065	1.69	1.82	0.095	4.03	4.05
B2B	0.055	1.03	1.10	0.065	1.60	1.72	0.095	3.83	3.94
B2C	0.045	0.54	0.67	0.055	0.88	1.05	0.080	2.21	2.30
B2D	0.055	0.72	0.92	0.065	1.15	1.39	0.090	2.82	2.82
B3A	0.055	1.03	1.12	0.065	1.59	1.71	0.100	3.85	3.89
B3B	0.060	1.24	1.43	0.070	1.90	2.12	0.105	4.53	4.55
B3C	0.055	1.07	1.12	0.065	1.65	1.72	0.105	4.00	4.23
B4A	0.030	0.09	0.17	0.035	0.19	0.26	0.055	0.58	0.65
B4B	0.030	0.10	0.18	0.035	0.20	0.28	0.065	0.62	0.73
B5A	0.025	0.07	0.14	0.030	0.11	0.20	0.045	0.39	0.46
B5B	0.025	0.06	0.11	0.030	0.10	0.17	0.045	0.38	0.43

See Appendix 'G' for calculations. Drawdown times have been summarized in Table 9, below.

Table 9: Roof Drain Drawdown Times

Roof Drain	Drawdown Time (min)		
	2-Year	5-Year	100-Year
B1A	32	50	126
B1B	30	48	122
B2A	58	89	213
B2B	55	85	203
B2C	29	46	117
B2D	38	61	149
B3A	54	84	204
B3B	65	100	239
B3C	57	87	211
B4A	4	10	31
B4B	5	11	33
B5A	4	6	21
B5B	4	5	20

In the event there is a rainfall above the 100-year storm event, or a blockage within the storm sewer system, emergency roof scuppers will direct flow to existing drainage routes.

7.6 Quality Control

The development of this lot will employ Best Management Practices (BMP's) wherever possible. The intent of implementing stormwater BMP's is to ensure that water quality and quantity concerns are addressed at all stages of development. Lot level BMP's typically include temporary retention of the parking lot runoff, minimizing ground slopes and maximizing landscaped areas. Some of these BMP's cannot be provided for this site due to site constraints and development requirements.

8.0 EROSION AND SEDIMENT CONTROL

8.1 Temporary Measures

Before construction begins, temporary silt fence, straw bale or rock flow check dams will be installed at all natural runoff outlets from the property. It is crucial that these controls be maintained throughout construction and inspection of sediment and erosion control will be facilitated by the Contractor or Contract Administration staff throughout the construction period.

Silt fences will be installed where shown on the final engineering plans, specifically along the downstream property limits. The Contractor, at their discretion or at the instruction of the City, Conservation Authority or the Contract Administrator shall increase the quantity of sediment and erosion controls on-site to ensure that the site is operating as intended and no additional sediment finds its way off site. The rock flow, straw bale & silt fence check dams and barriers shall be inspected weekly and after rainfall events. Care shall be taken to properly remove sediment from the fences and check dams as required. Fibre roll barriers are to be installed at all existing curb inlet catchbasins and filter fabric is to be placed under the grates of all existing catchbasins and manholes along the frontage of the site and any new structures immediately upon installation. The measures for the existing/proposed structures is to be removed only after all areas have been paved. Care shall be taken at the removal stage to ensure that any silt that has accumulated is properly handled and disposed of. Removal of silt fences without prior removal of the sediments shall not be permitted.

Although not anticipated, work through winter months shall be closely monitored for erosion along sloped areas. Should erosion be noted, the Contractor shall be alerted and shall take all necessary steps to rectify the situation. Should the Contractor's efforts fail at remediating the eroded areas, the Contractor shall contact the City and/or Conservation Authority to review the site conditions and determine the appropriate course of action. As the ground begins to thaw, the Contractor shall place silt fencing at all required locations as soon as ground conditions warrant. Please see the Site Grading, Drainage and Sediment & Erosion Control Plan for additional details regarding the temporary measures to be installed and their appropriate OPSD references.

8.2 Permanent Measures

It is expected that the Contractor will promptly ensure that all disturbed areas receive topsoil and seed/ sod and that grass be established as soon as possible. Any areas of excess fill shall be removed or levelled as soon as possible and must be located a sufficient distance from any watercourse to ensure that no sediment is washed out into the watercourse. As the vegetation growth within the site provides a key component to the control of sediment for the site, it must be properly maintained once established. Once the construction is complete, it will be up to the landowner to maintain the vegetation and ensure that the vegetation is not overgrown or impeded by foreign objects.

9.0 SUMMARY

- A new 595 m² ground floor area 7-storey apartment building will be constructed at 1940 Carling Avenue.
- Two new 150 mm water services will be installed to service the site, connecting to the watermain within Carling Avenue.
- A new 250 mm sanitary service will be installed to service the proposed apartment and connect to the existing sanitary maintenance hole sanitary sewer within Carling Avenue.
- Two new storm services will be installed, one foundation drain, and one roof drain, 250mm each. They will outlet to the existing 300 mm storm sewer within Carling Avenue. A series of landscaping catchbasins is proposed to collect drainage from the rear yard.
- Storage for the 2- through 100-year storm events will be provided on the proposed flat roof.

10.0 RECOMMENDATION

Based on the information presented in this report, we recommend that City of Ottawa approve this Servicing and Stormwater Management Report in support of the proposed Apartment Building.

This report is respectfully being submitted for approval.

Regards,

McIntosh Perry Consulting Engineers Ltd.



Charissa Hampel, P.Eng.
Project Engineer, Land Development
T: 613.714.4625
E: c.hampel@mcintoshperry.com

A handwritten signature in blue ink that reads "Francis Valenti".

Francis J. Valenti, EIT.
Engineering Intern, Land Development
T: 613.808.2123
E: f.valenti@mcintoshperry.com

11.0 STATEMENT OF LIMITATIONS

This report was produced for the exclusive use of Domenic Santaguida. The purpose of the report is to assess the existing stormwater management system and provide recommendations and designs for the post-construction scenario that are in compliance with the guidelines and standards from the Ministry of the Environment, Conservation and Parks, City of Ottawa and local approval agencies. McIntosh Perry reviewed the site information and background documents listed in Section 2.0 of this report. While the previous data was reviewed by McIntosh Perry and site visits were performed, no field verification/measures of any information were conducted.

Any use of this review by a third party, or any reliance on decisions made based on it, without a reliance report is the responsibility of such third parties. McIntosh Perry accepts no responsibility for damages, if any, suffered by any third party as a result of decisions or actions made based on this review.

The findings, conclusions and/or recommendations of this report are only valid as of the date of this report. No assurance is made regarding any changes in conditions subsequent to this date. If additional information is discovered or becomes available at a future date, McIntosh Perry should be requested to re-evaluate the conclusions presented in this report, and provide amendments, if required.

**APPENDIX A
SITE LOCATION PLAN**



LEGEND

- Site Location
- Local Road
- Major Road
- Watercourse
- Waterbody
- Wooded Area

REFERENCE

GIS data provided by the Ontario Ministry of Natural Resources and Forestry, 2021.

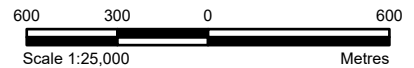

CLIENT:	DOMENIC SANTAGUIDA	
PROJECT:	PROPOSED APARTMENT 1940 CARLING AVENUE, OTTAWA, ON	
TITLE:	SITE LOCATION PLAN	
PROJECT NO.: CCO-20-0079	FIGURE:	1
Date	May, 28, 2021	
GIS	EU	
Checked By	NV	

McINTOSH PERRY
 115 Walgreen Road, RR3, Carp, ON K0A1L0
 Tel: 613-836-2184 Fax: 613-836-3742
 www.mcintoshperry.com

APPENDIX B
CITY OF OTTAWA PRE-CONSULTATION NOTES

Nicholas Vachon

From: Nicholas Vachon
Sent: May 26, 2021 2:19 PM
To: Nicholas Vachon
Subject: FW: Pre-Consultation Follow-Up: 1940 Carling Avenue

Nicholas Vachon, EIT

Engineering Intern
T. 613.903.5805

McINTOSH PERRY

Turning Possibilities Into Reality

From: McCreight, Laurel <Laurel.McCreight@ottawa.ca>
Sent: February 26, 2020 8:20 AM
To: Colleen Ivits <c.ivits@holzmanconsultants.com>
Subject: Pre-Consultation Follow-Up: 1940 Carling Avenue

Hello Vincent,

Please refer to the below regarding the Pre-Application Consultation Meeting held on February 13, 2020 for the property at 1940 Carling Avenue for Site Plan Control Applications in order to allow the development of a 7-storey apartment building. I have also attached the required Plans & Study List for application submission.

Below are staff's preliminary comments based on the information available at the time of pre-consultation meeting:

Planning / Urban Design

It is appreciated that the applicant is following the AM10 zoning provisions and the following comments are reflective of a Site Plan Control application only. As this is the first site on the south side of Carling Avenue to redevelop into an Arterial Mainstreet built form, this site will set the tone for the future redevelopment in this area of Carling Avenue. As a result, compatibility with the low-rise residential uses to the south and creating a new mainstreet presence along Carling Avenue is very important.

- All parking should be enclosed within the building.
 - With the existing low-rise residential uses to the south, the proposed surface parking at the rear of the site should be relocated inside the building to reduce noise, exhaust and headlight glare.
 - Any accessible parking should be located inside the building closest to the lobby and elevators.
- The AM zoning results in a building where units are facing the side yards as opposed to facing the rear and front yards.
 - This can create an issue of overlook as well as issues with the neighbouring properties redevelop in the same manner.
 - Consider a design which is more reflective of the R5 zoning provisions which results in a T-shaped building with residential units oriented towards the front and rear yards.
- The main entrance should be the predominant feature of the site, please extend the main entrance to the front face of the building rather than having it set back from the front wall of the building.

- In a multi-unit building such as this, bike storage, custodial rooms and other service areas are typically located mid-way or at the rear of the building.
 - Locating these areas at the front, significantly reduces any potential for animation along the front façade.
 - Relocate these spaces to other areas and consider locating a communal amenity space in the front or residential units to animate the front façade.
- There appears to be a number of mature trees at the northwest corner of the adjacent site (810 Dunlevie) and a mature cedar hedge along the shared property line which provides a natural buffer from this site.
 - These should be preserved, and all efforts should be made to protect them during construction.
- There appears to be a number of mature trees on the adjacent lots to the south of this site.
 - These should be preserved, and all efforts should be made to protect them during construction.
- Indoor bicycle parking is appreciated.
 - Consider adding a few bike parking spaces in the front yard for visitors.
- The Arterial Mainstreet guidelines provides a number of guidelines for the design of the streetscape specifically:
 - The sidewalk should be widened to 2.0 metres across the frontage of the site
 - Soft landscaping with salt tolerant shrubs and street trees should be included in the landscape design along the frontage
- There is no objection to the number of storeys; however, it is recommended that the average grade and height calculation be confirmed by a Development Information Officer as typically in a 20-metre height limit, the expectation is that the building would be six storeys, not seven.
- The site is within a Design Priority Area and meets the criteria to be reviewed by the Urban Design Review Panel.
 - An informal review is recommended and a formal will be required once a complete application has been submitted and circulated.
 - Please visit the webpage for submission requirements and UDRP meeting dates.

Engineering

General:

- It is the sole responsibility of the consultant to investigate the location of existing underground utilities in the proposed servicing area and submit a request for locates. The location of existing utilities and services shall be documented on an **Existing Conditions Plan**.
- All underground and above ground building footprints and permanent walls need to be shown on the plans to confirm that any permanent structure does not encroach within the right-of-way.
- Any easements on the subject site shall be identified and respected by any development proposal and shall adhere to the conditions identified in the easement agreement. A **legal survey plan** shall be provided and all easements shall be shown on the engineering plans.
- Please provide an **Existing Conditions/Removals Plan** as part of the engineering drawing set. Any existing services are to be removed or abandoned in accordance with City standards.
- Please note that the proposed servicing design and site works shall be in accordance with the following documents:
 - Ottawa Sewer Design Guidelines (October 2012)
 - Technical Bulletin PIEDTB-2016-01
 - Technical Bulletins ISTB-2018-01, ISTB-2018-02 and ISTB-2018-03.
 - Ottawa Design Guidelines - Water Distribution (2010)
 - Geotechnical Investigation and Reporting Guidelines for Development Applications in the City of Ottawa (2007)
 - City of Ottawa Slope Stability Guidelines for Development Applications (revised 2012)
 - City of Ottawa Environmental Noise Control Guidelines (January 2016)
 - City of Ottawa Accessibility Design Standards (2012) (City recommends development be in accordance with these standards on private property)
 - Ottawa Standard Tender Documents (latest version)

- Ontario Provincial Standards for Roads & Public Works (2013)
- Record drawings and utility plans are also available for purchase from the City (Contact the City's Information Centre by email at InformationCentre@ottawa.ca or by phone at (613) 580-424 x.44455).

Stormwater Management Criteria and Information:

- Based on the install year, the **storm sewer system within this area was only designed to a 2-year level of service** not a 5-year level of service [pre-1970 the design of the storm sewers were based on a 2-year storm].
- **Water Quantity Control:** In the absence of area specific SWM criteria please control post-development runoff from the subject site(s), up to and including the 100-year storm event, to a **2-year allowable release rate** calculated using an allowable runoff coefficient (C) determined using the pre-development (existing) runoff coefficient or a maximum equivalent 'C' of 0.5 (whichever is less) [If 0.5 applies it needs to be clearly demonstrated in the report that the pre-development runoff coefficient is greater than 0.5], and a calculated time of concentration (T_c) using an appropriate method to justify the parameter selection or T_c of minutes [*T_c of 20 minutes should be used for all pre-development calculations without engineering justification, T_c should not be less than 10 min. since IDF curves become unrealistic at less than 10 min; T_c of 10 minutes shall be used for all post-development calculations*].
- Any storm events greater than the established 2-year allowable release rate, up to and including the 100-year storm event, shall be detained on site. The SWM solution will be subject to review.
- **Water Quality Control:** Please consult with the local conservation authority regarding water quality criteria prior to submission of a Site Plan Control Proposal application to establish any water quality control restrictions, criteria and measures for the site. Correspondence and clearance shall be provided in the Appendix of the report.
- Please note that foundation drain is to be independently connected to sewermain unless being pumped with appropriate back up power, sufficient sized pump and back flow prevention.
- Please note that as per *Technical Bulletin PIEDTB-2016-01 section 8.3.11.1 (p.12 of 14)* **there shall be no surface ponding on private parking areas during the 2-year storm rainfall event.** Depending on the SWM strategy proposed underground or additional underground storage may be required to satisfy this requirement.
- **Underground Storage:** Please note that the Modified Rational Method for storage computation in the Sewer Design Guidelines was originally intended to be used for above ground storage (i.e. parking lot) where the change in head over the orifice varied from 1.5 m to 1.2 m (assuming a 1.2 m deep CB and a max ponding depth of 0.3 m). This change in head was small and hence the release rate fluctuated little, therefore there was no need to use an average release rate.
- When underground storage is used, the release rate fluctuates from a maximum peak flow based on maximum head down to a release rate of zero. This difference is large and has a significant impact on storage requirements. **We therefore require that an average release rate equal to 50% of the peak allowable rate shall be applied to estimate the required volume. Alternatively, the consultant may choose to use a submersible pump in the design to ensure a constant release rate.**
- In the event that there is a disagreement from the designer regarding the required storage, The City will require that the designer demonstrate their rationale utilizing dynamic modelling, that will then be reviewed by City modellers in the Water Resources Group.
- Note that the above will added to upcoming revised Sewer Design Guidelines to account for underground storage, which is now widely used.
- Provide sufficient details and information on any proposed underground storage system. A cross-section of any underground storage system is to be provided with sufficient details and information. In case of a pump failure or blockage an overflow should be provided. Backup power supply is required if using a pump.
- Please note that the minimum orifice dia. for a plug style ICD is 83mm and the minimum flow rate from a vortex ICD is 6 L/s in order to reduce the likelihood of plugging.
- Post-development site grading shall match existing property line grades in order to minimize disruption to the adjacent residential properties. A **topographical plan of survey** shall be provided as part of the submission and a note provided on the plans.
- Please provide a **Pre-Development Drainage Area Plan** to define the pre-development drainage areas/patterns. **Existing drainage patterns shall be maintained and discussed as part of the proposed SWM solution.**

- If rooftop control and storage is proposed as part of the SWM solutions sufficient details (Cl. 8.3.8.4) shall be discussed and document in the report and on the plans. Roof drains are to be connected downstream of any incorporated ICDs within the SWM system and not to the foundation drain system.

Storm Sewer:

- Storm sewer monitoring maintenance holes are required to be installed at the property line (on the private side of the property) as per City of Ottawa Sewer-Use By-Law 2003-514 (14) *Monitoring Devices*.
- As-built drawings of the existing services within the vicinity of the site shall be obtained and reviewed in order to determine proper servicing and SWM plan for the subject site(s).
- Storm service connections are to have backwater valves.

Sanitary Sewer:

- **An analysis and demonstration that there is sufficient/adequate residual capacity to accommodate any increase in wastewater flows in the receiving and downstream wastewater system is required to be provided. It is suggested to calculate the total wastewater demand for the proposed development and send it to the City as soon as possible, as an initial step to determine whether or not there is enough capacity in the city system to accommodate the proposed wastewater flow.** Please note that it takes approx. 10 business days to get a response back from the internal circulation.
- Please apply the wastewater design flow parameters in *Technical Bulletin PIEDTB-2018-01*.
- Sanitary sewer monitoring maintenance holes are required to be installed at the property line (on the private side of the property) as per City of Ottawa Sewer-Use By-Law 2003-514 (14) *Monitoring Devices*.
- Sanitary service connections are to have backwater valves.

Water:

- **Water Supply Redundancy:** Residential buildings with a basic day demand greater than 50m³/day (0.57 L/s) are required to be connected to a minimum of two water services separated by an isolation valve to avoid a vulnerable service area as per the *Ottawa Design Guidelines - Water Distribution, WDG001, July 2010 Clause 4.3.1 Configuration*. The basic day demand for each site anticipated to exceed 50m³/day therefore 2 water services will be required. There shall be primary water service and a secondary connection.
- Please review Technical Bulletin ISTB-2018-0, maximum fire flow hydrant capacity is provided in Section 3 Table 1 of Appendix I. A **hydrant coverage figure** shall be provided and **demonstrate there is adequate fire protection**.
- Boundary conditions are required to confirm that the require fire flows can be achieved as well as availability of the domestic water pressure on the City street in front of the development. Use Table 3-3 of the MOE Design Guidelines for Drinking-Water System to determine Maximum Day and Maximum Hour peaking factors for 0 to 500 persons and use Table 4.2 of the Ottawa Design Guidelines, Water Distribution for 501 to 3,000 persons. Please provide the following information to the City of Ottawa via email to request water distribution network boundary conditions for the subject site. Please note that once this information has been provided to the City of Ottawa it takes approximately 5-10 business days to receive boundary conditions.
 - Type of Development and Units
 - Site Address
 - A plan showing the proposed water service connection locations.
 - **Average Daily Demand (L/s)**
 - **Maximum Daily Demand (L/s)**
 - **Peak Hour Demand (L/s)**
 - **Fire Flow (L/min)**
 - *[Fire flow demand requirements shall be based on Fire Underwriters Survey (FUS) Water Supply for Public Fire Protection*
 - *1999]*
 - *Exposure separation distances shall be defined on a figure to support the FUS calculation and required fore flow (RFF).*

- Hydrant capacity shall be assessed to demonstrate the RFF can be achieved. Please identify which hydrants are being considered to meet the RFF on a fire hydrant coverage plan as part of the boundary conditions request.
- The subject site is located within the 1E Pressure Zone.

Snow Storage:

- Any portion of the subject property which is intended to be used for permanent or temporary snow storage shall be as shown on the approved site plan and grading plan. Snow storage shall not interfere with approved grading and drainage patterns or servicing. Snow storage areas shall be setback from the property lines, foundations, fencing or landscaping a minimum of 1.5m. Snow storage areas shall not occupy driveways, aisles, required parking spaces or any portion of a road allowance. If snow is to be removed from the site please indicate this on the plan(s).

Permits and Approvals:

- The consultant shall determine if this project will be subject to an Environmental Compliance Approval (ECA) for Private Sewage Works. It shall be determined if the exemptions set out under Ontario Regulation 525/98: *Approval Exemptions* are satisfied. All regulatory approvals shall be documented and discussed in the report.

Geotechnical Investigation:

- A Geotechnical Study/Investigation shall be prepared in support of this development proposal.
- Reducing the groundwater level in this area can lead to potential damages to surrounding structures due to excessive differential settlements of the ground. The impact of groundwater lowering on adjacent properties needs to be discussed and investigated to ensure there will be no short term and long term damages associated with lowering the groundwater in this area.
- Geotechnical Study shall be consistent with the **Geotechnical Investigation and Reporting Guidelines for Development Applications**.
- <https://documents.ottawa.ca/sites/default/files/documents/cap137602.pdf>

Exterior Site Lighting:

- Any proposed light fixtures (both pole-mounted and wall mounted) must be part of the approved Site Plan. All external light fixtures must meet the criteria for Full Cut-off Classification as recognized by the Illuminating Engineering Society of North America (IESNA or IES), and must result in minimal light spillage onto adjacent properties (as a guideline, 0.5 fc is normally the maximum allowable spillage). In order to satisfy these criteria, the please provide the City with a **Site Lighting Plan, Photometric Plan and Certification (Statement) Letter** from an acceptable professional engineer stating that the design is compliant.

Please contact Infrastructure Project Manager, Ahmed Elsayed, for follow-up questions.

Transportation

- Follow Traffic Impact Assessment Guidelines
 - Submit a screening form. If a TIA is warranted proceed to scoping.
- ROW protection on Carling is 44.5 metres.
 - A reduction in the road widening was requested from 7 metres to 4 metres (parking levels P1 and P2, as well as at-grade) and from 7 metres to 0 metres (parking levels P3 – P7)
 - No issues with this request
- A Noise Impact Study is required.
- Be aware of possible transit priority measure son Carling- see Ottawa website for plans.

Please contact Transportation Project Manager, Mike Giampa, for follow-up questions.

Forestry

- A Tree Conservation Report (TCR) must be supplied for review along with the suite of other plans/reports required by the City; an approved TCR is a requirement of Site Plan or Plan of Subdivision approval
- Any removal of privately-owned trees 10cm or larger in diameter requires a tree permit issued under the Urban Tree Conservation Bylaw; the permit is based on the approved TCR
- The removal of City-owned trees will require the permission of Forestry Services who will also review the submitted TCR
- In this case, the TCR may be combined with the Landscape Plan or it may be a stand-alone plan; a plan form is preferred provided it has all the relevant information.
- The TCR must list all trees on site by species, diameter and health condition – separate stands/groupings of trees may be combined using averages
- The TCR must address all trees with a critical root zone that extends into the developable area – all trees that could be impacted by the construction that are outside the developable area need to be addressed.
- Trees with a trunk that crosses/touches a property line are considered co-owned by both property owners; permission from the adjoining property owner must be obtained prior to the removal of co-owned trees
- If trees are to be removed, the TCR must clearly show where they are, and document the reason they can not be retained – please provide a plan showing retained and removed treed areas
- All retained trees must be shown and all retained trees within the area impacted by the development process must be protected as per City guidelines listed on Ottawa.ca
- Butternut is common in the vicinity of the site – please address any butternut identified within a regulated distance from the property
- The City encourages the retention of healthy trees; if possible, please seek opportunities for retention of trees that will contribute to the design/function of the site.
- Please ensure newly planted trees have an adequate soil volume for their size at maturity. The following is a table of recommended minimum soil volumes:

Tree Type/Size	Single Tree Soil Volume (m3)	Multiple Tree Soil Volume (m3/tree)
Ornamental	15	9
Columnar	15	9
Small	20	12
Medium	25	15
Large	30	18
Conifer	25	15

- Please contact Forester, Mark Richardson for follow-up questions.

Parkland

- Cash-in-lieu of parkland will be required equivalent to ten per cent of the value of the land area of the site being developed.

Other

Please refer to the links to “Guide to preparing studies and plans” and [fees](#) for general information. Additional information is available related to building permits, [development charges](#), and [the Accessibility Design Standards](#). Be aware that other fees and permits may be required, outside of the development review process. You may obtain background drawings by contacting informationcentre@ottawa.ca.

These pre-consultation comments are valid for one year. If you submit a development application(s) after this time, you may be required to meet for another pre-consultation meeting and/or the submission requirements may change. You

are also encouraged to contact us for a follow-up meeting if the plan/concept will be further refined. It is recommended to reach out to the local ward Councillor (Theresa Kavanagh) to discuss the proposal prior to submitting any formal applications.

Please do not hesitate to contact me if you have any questions.

Regards,
Laurel

Laurel McCreight MCIP, RPP

Planner

Development Review West

Urbaniste

Examen des demandes d'aménagement ouest

City of Ottawa | Ville d'Ottawa

☎ 613.580.2424 ext./poste 16587

ottawa.ca/planning / ottawa.ca/urbanisme

This e-mail originates from the City of Ottawa e-mail system. Any distribution, use or copying of this e-mail or the information it contains by other than the intended recipient(s) is unauthorized. Thank you.

Le présent courriel a été expédié par le système de courriels de la Ville d'Ottawa. Toute distribution, utilisation ou reproduction du courriel ou des renseignements qui s'y trouvent par une personne autre que son destinataire prévu est interdite. Je vous remercie de votre collaboration.

Nicholas Vachon

From: Curtis Melanson
Sent: July 8, 2022 11:42 AM
To: Nicholas Vachon
Subject: FW: 1940 Carling

From: Dieme, Abi <Abibatou.Dieme@ottawa.ca>
Sent: October 27, 2021 9:35 AM
To: Curtis Melanson <c.melanson@mcintoshperry.com>
Cc: Nicholas Vachon <n.vachon@mcintoshperry.com>
Subject: RE: 1940 Carling

Hi Curtis,

City Asset Management Branch will accept an excess release rate of 7l/s for the 100 year-event. Please proceed with your design.

Regards,
Abi

From: Dieme, Abi
Sent: October 27, 2021 8:39 AM
To: Curtis Melanson <c.melanson@mcintoshperry.com>
Cc: Nicholas Vachon <n.vachon@mcintoshperry.com>
Subject: RE: 1940 Carling

Hi Curtis,

I have just sent a follow up email to the Senior Engineer in Asset Management. I'll get back to you when I receive a response.

Regards,
Abi

From: Curtis Melanson <c.melanson@mcintoshperry.com>
Sent: October 27, 2021 8:16 AM
To: Dieme, Abi <Abibatou.Dieme@ottawa.ca>
Cc: Nicholas Vachon <n.vachon@mcintoshperry.com>
Subject: RE: 1940 Carling

CAUTION: This email originated from an External Sender. Please do not click links or open attachments unless you recognize the source.

ATTENTION : Ce courriel provient d'un expéditeur externe. Ne cliquez sur aucun lien et n'ouvrez pas de pièce jointe, excepté si vous connaissez l'expéditeur.

Hi Abi,

Following up on the below, it's been 2 weeks. Can you please provide confirmation that the minimal storm increase is acceptable? We'd like to get this into the City ASAP!

Thanks,

Curtis Melanson, C.E.T.

Practice Area Lead, Land Development

115 Walgreen Road, R.R. 3, Carp, ON K0A 1L0

T. 613.714.4621 | F. 613.836.3742 | C. 613.857.0784

c.melanson@mcintoshperry.com | www.mcintoshperry.com

McINTOSH PERRY

From: Curtis Melanson <c.melanson@mcintoshperry.com>

Sent: October 13, 2021 8:52 AM

To: Dieme, Abi <Abibatou.Dieme@ottawa.ca>

Cc: Nicholas Vachon <n.vachon@mcintoshperry.com>

Subject: RE: 1940 Carling

Hi Abi,

Thanks for your time at the end of last week. As we discussed, we're having a difficult time achieving the required stormwater management flow rates for this site due to the building/underground parking extents as well as site constraints.

The site is to be restricted to the 2 year storm event which provides an allowable release rate of 11.98 L/s. We've restricted the building roof as much as possible, however, due to the site/building constraints at the front and back of the site, these areas leave unrestricted resulting in 16.81 L/s of unrestricted flow (in the 100 year storm) which is already above the allowable 11.98 L/s. We are able to meet the required restriction for the 2 and 5 year storm events. The only issue is the 100 year storm. The total flow leaving the site in a 100 year storm event would be 19.15 L/s (which is just over 7 L/s above the allowable flow).

Please see attached calculations and post development plan. Can you please review and confirm that we can proceed with a higher release in the 100 year storm event?

If there's any questions/clarification required please feel free to call or email.

Thanks,

Curtis Melanson, C.E.T.

Practice Area Lead, Land Development

115 Walgreen Road, R.R. 3, Carp, ON K0A 1L0

T. 613.714.4621 | F. 613.836.3742 | C. 613.857.0784

c.melanson@mcintoshperry.com | www.mcintoshperry.com

McINTOSH PERRY

From: Dieme, Abi <Abibatou.Dieme@ottawa.ca>

Sent: October 7, 2021 1:22 PM

To: Curtis Melanson <c.melanson@mcintoshperry.com>

Cc: Nicholas Vachon <n.vachon@mcintoshperry.com>

Subject: RE: 1940 Carling

I have just sent you an invite for 30min Teams call but if you think we'll need more time I am available on Monday.

Regards,
Abi

From: Curtis Melanson <c.melanson@mcintoshperry.com>
Sent: October 07, 2021 11:04 AM
To: Dieme, Abi <Abibatou.Dieme@ottawa.ca>
Cc: Nicholas Vachon <n.vachon@mcintoshperry.com>
Subject: RE: 1940 Carling

CAUTION: This email originated from an External Sender. Please do not click links or open attachments unless you recognize the source.

ATTENTION : Ce courriel provient d'un expéditeur externe. Ne cliquez sur aucun lien et n'ouvrez pas de pièce jointe, excepté si vous connaissez l'expéditeur.

Hi Abi,

Could we discuss at 10:30am, I have a meeting starting at 11 and then tied up with other items for the remainder of the day.

Cheers,

Curtis Melanson, C.E.T.

Practice Area Lead, Land Development

115 Walgreen Road, R.R. 3, Carp, ON K0A 1L0

T. 613.714.4621 | F. 613.836.3742 | C. 613.857.0784

c.melanson@mcintoshperry.com | www.mcintoshperry.com

McINTOSH PERRY

From: Dieme, Abi <Abibatou.Dieme@ottawa.ca>
Sent: October 7, 2021 8:10 AM
To: Curtis Melanson <c.melanson@mcintoshperry.com>
Cc: Nicholas Vachon <n.vachon@mcintoshperry.com>
Subject: RE: 1940 Carling

Hi Curtis,

I am booked for the day. I can set up a Teams call tomorrow after 10:30. Please advise what time would be best for you.

Regards,
Abi

From: Curtis Melanson <c.melanson@mcintoshperry.com>
Sent: October 06, 2021 10:02 AM
To: Dieme, Abi <Abibatou.Dieme@ottawa.ca>
Cc: Nicholas Vachon <n.vachon@mcintoshperry.com>
Subject: FW: 1940 Carling

CAUTION: This email originated from an External Sender. Please do not click links or open attachments unless you recognize the source.

ATTENTION : Ce courriel provient d'un expéditeur externe. Ne cliquez sur aucun lien et n'ouvrez pas de pièce jointe, excepté si vous connaissez l'expéditeur.

Hi Abi,

As discussed previously, we need to chat with you regarding the above site as we are having difficulties meeting SWM criteria based on site conditions.

Can you let me know when you have some time to discuss tomorrow around 11 am?

Cheers,

Curtis Melanson, C.E.T.

Practice Area Lead, Land Development

115 Walgreen Road, R.R. 3, Carp, ON K0A 1L0

T. 613.714.4621 | F. 613.836.3742 | C. 613.857.0784

c.melanson@mcintoshperry.com | www.mcintoshperry.com

McINTOSH PERRY

Turning Possibilities Into Reality

Confidentiality Notice – If this email wasn't intended for you, please return or delete it. Click [here](#) to read all of the legal language around this concept.



Platinum
member



From: Nicholas Vachon <n.vachon@mcintoshperry.com>

Sent: October 6, 2021 9:43 AM

To: Curtis Melanson <c.melanson@mcintoshperry.com>

Subject: 1940 Carling

Hey Curtis,

Post and SWM

Nicholas Vachon, EIT

Engineering Intern

T. 613.903.5805

McINTOSH PERRY

Turning Possibilities Into Reality

,

This e-mail originates from the City of Ottawa e-mail system. Any distribution, use or copying of this e-mail or the information it contains by other than the intended recipient(s) is unauthorized. Thank you.

Le présent courriel a été expédié par le système de courriels de la Ville d'Ottawa. Toute distribution, utilisation ou reproduction du courriel ou des renseignements qui s'y trouvent par une personne autre que son destinataire prévu est interdite. Je vous remercie de votre collaboration.

,

This e-mail originates from the City of Ottawa e-mail system. Any distribution, use or copying of this e-mail or the information it contains by other than the intended recipient(s) is unauthorized. Thank you.

Le présent courriel a été expédié par le système de courriels de la Ville d'Ottawa. Toute distribution, utilisation ou reproduction du courriel ou des renseignements qui s'y trouvent par une personne autre que son destinataire prévu est interdite. Je vous remercie de votre collaboration.

,

This e-mail originates from the City of Ottawa e-mail system. Any distribution, use or copying of this e-mail or the information it contains by other than the intended recipient(s) is unauthorized. Thank you.

Le présent courriel a été expédié par le système de courriels de la Ville d'Ottawa. Toute distribution, utilisation ou reproduction du courriel ou des renseignements qui s'y trouvent par une personne autre que son destinataire prévu est interdite. Je vous remercie de votre collaboration.

,

Francis Valenti

Subject: FW: 1940 Carling - Quality Control Requirements

From: Eric Lalande <eric.lalande@rvca.ca>
Sent: August 2, 2022 11:27 AM
To: Nicholas Vachon <n.vachon@mcintoshperry.com>
Subject: RE: 1940 Carling - Quality Control Requirements

Hi Nicolas,

The RVCA has no on-site water quality control requirements for the project as presented on the site plan. Best management practices are encouraged to be implemented where possible.

Thanks,

Eric Lalande, MCIP, RPP
Planner, RVCA
613-692-3571 x1137

From: Nicholas Vachon <n.vachon@mcintoshperry.com>
Sent: Tuesday, August 2, 2022 11:05 AM
To: Eric Lalande <eric.lalande@rvca.ca>
Subject: 1940 Carling - Quality Control Requirements

Hi Eric,

See attached site plan for a project that we're working on at 1940 Carling. The site currently consists of a single home with asphalt driveway and landscaping which will be demolished. A new 7-storey residential apartment building will be built and occupy almost the entire site area, complete with underground parking. The remainder of the site consists of small pervious areas around the building with the exception of the underground parking entrance and walkway at the front entrance.

We're providing quantity control of the storm runoff but can you confirm if we require quality control? Since the site consists almost entirely of roof area in post development conditions I assume it's not warranted but wanted to check and see if anything would be required.

If you have any questions or concerns please don't hesitate to get back to me whenever you have a moment.

Nicholas Vachon, EIT
Engineering Intern
T. 613.903.5805
n.vachon@mcintoshperry.com | www.mcintoshperry.com

McINTOSH PERRY
Turning Possibilities Into Reality

Confidentiality Notice – If this email wasn't intended for you, please return or delete it. Click [here](#) to read all of the legal language around this concept.

APPENDIX C
WATERMAIN CALCULATIONS

McINTOSH PERRY

CP-20-0079 - 1940 Carling Ave - Water Demands

Project:	1940 Carling Ave
Project No.:	CP-20-0079
Designed By:	FV
Checked By:	NV
Date:	July 29, 2022
Site Area:	0.15 gross ha

Residential	NUMBER OF UNITS	UNIT RATE	
Bachelor Apartment	33 units	1.4	persons/unit
1 Bedroom Apartment	25 units	1.4	persons/unit
2 Bedroom Apartment	6 units	2.1	persons/unit
Total Population	94 persons		

AVERAGE DAILY DEMAND

DEMAND TYPE	AMOUNT	UNITS	
Residential	280	L/c/d	
Industrial - Light	35,000	L/gross ha/d	
Industrial - Heavy	55,000	L/gross ha/d	
Shopping Centres	2,500	L/(1000m ² /d)	
Hospital	900	L/(bed/day)	
Schools	70	L/(Student/d)	
Trailer Park with no Hook-Ups	340	L/(space/d)	
Trailer Park with Hook-Ups	800	L/(space/d)	
Campgrounds	225	L/(campsite/d)	
Mobile Home Parks	1,000	L/(Space/d)	
Motels	150	L/(bed-space/d)	
Hotels	225	L/(bed-space/d)	
Tourist Commercial	28,000	L/gross ha/d	
Other Commercial	28,000	L/gross ha/d	
AVERAGE DAILY DEMAND Residential		0.30	L/s
AVERAGE DAILY DEMAND Commercial/ Industrial/ Institutional		0.00	L/s

MAXIMUM DAILY DEMAND

DEMAND TYPE	AMOUNT	UNITS	
Residential	2.5	x avg. day	L/c/d
Industrial	1.5	x avg. day	L/gross ha/d
Commercial	1.5	x avg. day	L/gross ha/d
Institutional	1.5	x avg. day	L/gross ha/d
MAXIMUM DAILY DEMAND Residential		0.76	L/s
MAXIMUM DAILY DEMAND Commercial/ Industrial/ Institutional		0.00	L/s

MAXIMUM HOUR DEMAND

DEMAND TYPE	AMOUNT	UNITS	
Residential	2.2	x max. day	L/c/d
Industrial	1.8	x max. day	L/gross ha/d
Commercial	1.8	x max. day	L/gross ha/d
Institutional	1.8	x max. day	L/gross ha/d
MAXIMUM HOUR DEMAND Residential		1.68	L/s
MAXIMUM HOUR DEMAND Commercial/ Industrial/ Institutional		0.00	L/s

WATER DEMAND DESIGN FLOWS PER UNIT COUNT
CITY OF OTTAWA - WATER DISTRIBUTION GUIDELINES, JULY 2010

AVERAGE DAILY DEMAND	0.30	L/s
MAXIMUM DAILY DEMAND	0.76	L/s
MAXIMUM HOUR DEMAND	1.68	L/s

McINTOSH PERRY

CP-20-0079 - 1940 Carling Ave - OBC Fire Calculations

Project:	1940 Carling Ave
Project No.:	CP-20-0079
Designed By:	FV
Checked By:	NV
Date:	July 29, 2022

Ontario 2006 Building Code Compendium (Div. B - Part 3)

Water Supply for Fire-Fighting - Store/ Office & Warehouse Building

Building is classified as Group : **C- Residential** (from table 3.2.2.55)
 Building is of combustible construction with fire separations and fire resistance ratings provided in accordance with Subsection 3.2.2., including loadbearing walls, columns and arches. Noncombustible construction may be used in lieu of fire-resistance rating

From Div. B A-3.2.5.7. of the Ontario Building Code - 3. Building On-Site Water Supply:

(a) $Q = K \times V \times S_{tot}$

where:

Q = minimum supply of water in litres

K = water supply coefficient from Table 1

V = total building volume in cubic metres

S_{tot} = total of spatial coefficient values from the property line exposures on all sides as obtained from the formula:

$S_{tot} = 1.0 + [S_{side1} + S_{side2} + S_{side3} + \dots \text{etc.}]$

K	18	(from Table 1 pg A-31) (Worst case occupancy {E/ F2} 'K' value used)
V	12,935	(Total building volume in m ³ .)
S _{tot}	2.0	(From figure 1 pg A-32)
Q =	465,668.22 L	

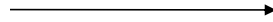

			From Figure 1 (A-32)
S _{north}	7.3 m	0.3	
S _{east}	1.7 m	0.5	
S _{south}	7.5 m	0.2	
S _{west}	1.2 m	0.5	

* approximate distances

From Table 2: Required Minimum Water Supply Flow Rate (L/s)

9000 L/min if Q > 270,000 L
 2378 gpm

McINTOSH PERRY

CP-20-0079 - 1940 Carling Ave - Fire Underwriters Survey

Project: 1940 Carling Ave
 Project No.: CP-20-0079
 Designed By: FV
 Checked By: NV
 Date: July 29, 2022

From the Fire Underwriters Survey (2020)

From Part II – Guide for Determination of Required Fire Flow Copyright I.S.O.:
 City of Ottawa Technical Bulletin ISTB-2018-02 Applied Where Applicable

A. BASE REQUIREMENT (Rounded to the nearest 1000 L/min)

F = 220 x C x v^A Where: F = Required fire flow in liters per minute
 C = Coefficient related to the type of construction.
 A = The total floor area in square meters (including all storey's, but excluding basements at least 50 percent below grade) in the building being considered.

Construction Type Non-Combustible Construction

C 0.8 A 4,544.0 m²

Total Floor Area (per the 2020 FUS Page 20 - Total Effective Area) 3,720.8 m²

Calculated Fire Flow 10,735.7 L/min
 11,000.0 L/min

B. REDUCTION FOR OCCUPANCY TYPE (No Rounding)

From Page 24 of the Fire Underwriters Survey:
 Limited Combustible -15%

Fire Flow 9,350.0 L/min

C. REDUCTION FOR SPRINKLER TYPE (No Rounding)

Standard Water Supply Sprinklered -40%

Reduction -3,740.0 L/min

D. INCREASE FOR EXPOSURE (No Rounding)

	Separation Distance (m)	Cons. of Exposed Wall	Length Exposed Adjacent Wall (m)	Height (Stories)	Length-Height Factor	
Exposure 1	Over 30 m	Wood frame	N/A	N/A	N/A	0%
Exposure 2	10.1 to 20	Wood frame	29.96	1	30.0	11%
Exposure 3	Over 30 m	Wood frame	N/A	N/A	N/A	0%
Exposure 4	3.1 to 10	Wood frame	8.6	2	17.2	15%
					% Increase*	26%

Increase* 2,431.0 L/min

E. Total Fire Flow (Rounded to the Nearest 1000 L/min)

Fire Flow 8,041.0 L/min
 Fire Flow Required** 8,000.0 L/min

* In accordance with Part II, Section 4, the Increase for separation distance is not to exceed 75%

** In accordance with Section 4 the Fire flow is not to exceed 45,000 L/min or be less than 2,000 L/min

McINTOSH PERRY

CP-20-0079-01 - 1940 Carling - Boundary Condition Unit Conversion

Project: 1940 Carling Ave

Project No.: CP-20-0079

Designed By: BS

Checked By: RK

Date: May 27, 2021

Boundary Conditions Unit Conversion

Carling Avenue

Scenario	Height (m)	Elevation (m)	m H ₂ O	PSI	kPa
Avg. DD	114.5	79.15	35.4	50.3	346.8
Fire Flow (267 L/s or 16,000 L/min)	114.5	79.15	35.4	50.3	346.8
Peak Hour	108.6	79.15	29.5	41.9	289.0

Hydrant Cover Figure

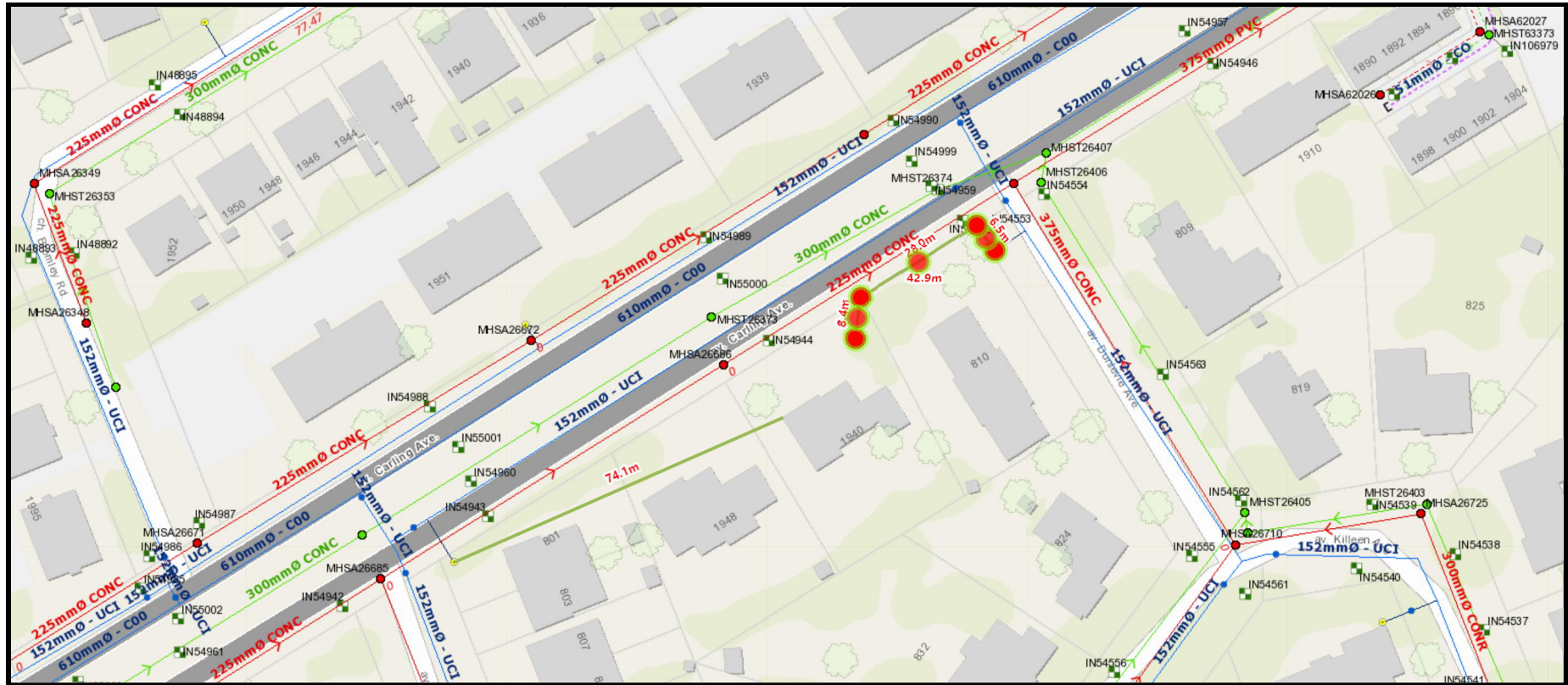

Boundary Condition for 1940 Carling

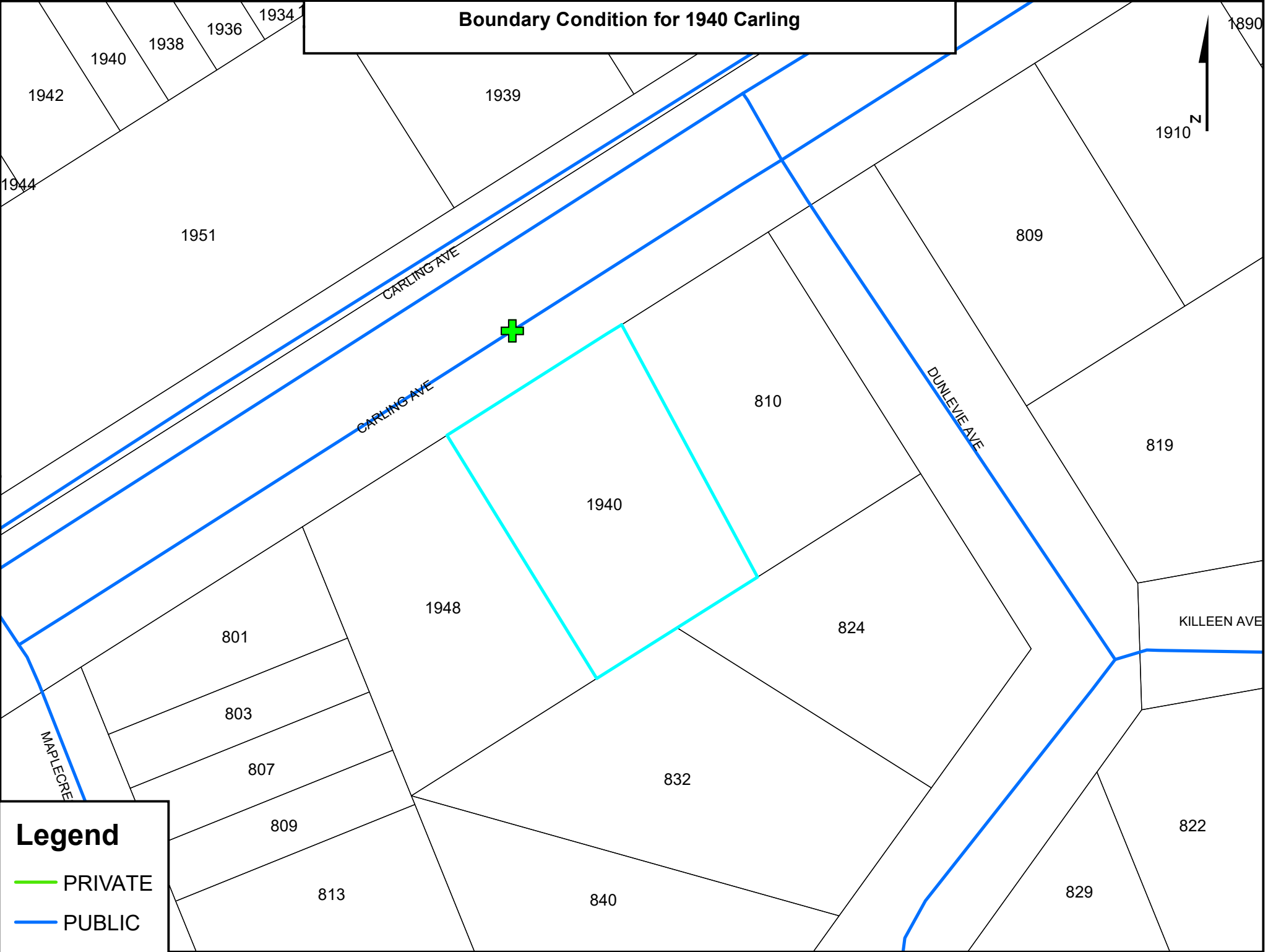

Legend

- PRIVATE
- PUBLIC



Nicholas Vachon

From: Elsayed, Ahmed <ahmed.elsayed@ottawa.ca>
Sent: April 20, 2021 9:53 AM
To: Braden Stuyt
Subject: RE: Boundary Conditions Request - 1940 Carling Avenue
Attachments: 1940 Carling April 2021.pdf

Hi Braden,

Below is the BC.

The following are boundary conditions, HGL, for hydraulic analysis at 1940 Carling (zone 1W) assumed to be connected to the 152 mm on Carling Ave (see attached PDF for location).

Minimum HGL = 108.6 m

Maximum HGL = 114.5 m

Available Fire Flow @ 20 psi = 66 L/s assuming a ground elevation of 81.4 m

These are for current conditions and are based on computer model simulation.

Disclaimer: The boundary condition information is based on current operation of the city water distribution system. The computer model simulation is based on the best information available at the time. The operation of the water distribution system can change on a regular basis, resulting in a variation in boundary conditions. The physical properties of watermains deteriorate over time, as such must be assumed in the absence of actual field test data. The variation in physical watermain properties can therefore alter the results of the computer model simulation.

Thanks,
Ahmed

From: Braden Stuyt <B.Stuyt@McIntoshPerry.com>
Sent: Wednesday, April 14, 2021 9:10 AM
To: Elsayed, Ahmed <ahmed.elsayed@ottawa.ca>
Subject: Boundary Conditions Request - 1940 Carling Avenue

CAUTION: This email originated from an External Sender. Please do not click links or open attachments unless you recognize the source.

ATTENTION : Ce courriel provient d'un expéditeur externe. Ne cliquez sur aucun lien et n'ouvrez pas de pièce jointe, excepté si vous connaissez l'expéditeur.

Hi Ahmed,

I have conducted the fire flow calculations with the information available and would like to request boundary conditions for the development located on 1940 Carling Avenue. I have attached our preliminary calculations and a location plan for reference. If you could please provide boundary conditions?

Please find the below fire flow to obtain boundary conditions.

Type of Development:	Residential
----------------------	-------------

Location of Service:	1940 Carling Avenue
Amount of Fire Flow Required (FUS):	13,000 L/ min
Site Area (ha):	0.15

If you require any further information or have any questions, please feel free to contact me.

Thank you,

Braden Stuyt

Engineering Intern - Land Development

115 Walgreen Road, Carp, ON K0A 1L0

T. 343.925.0163 | C. 343.364.3458

B.Stuyt@McIntoshPerry.com | www.mcintoshperry.com

McINTOSH PERRY

Confidentiality Notice – If this email wasn't intended for you, please return or delete it. Click [here](#) to read all of the legal language around this concept.



Platinum member



This e-mail originates from the City of Ottawa e-mail system. Any distribution, use or copying of this e-mail or the information it contains by other than the intended recipient(s) is unauthorized. Thank you.

Le présent courriel a été expédié par le système de courriels de la Ville d'Ottawa. Toute distribution, utilisation ou reproduction du courriel ou des renseignements qui s'y trouvent par une personne autre que son destinataire prévu est interdite. Je vous remercie de votre collaboration.

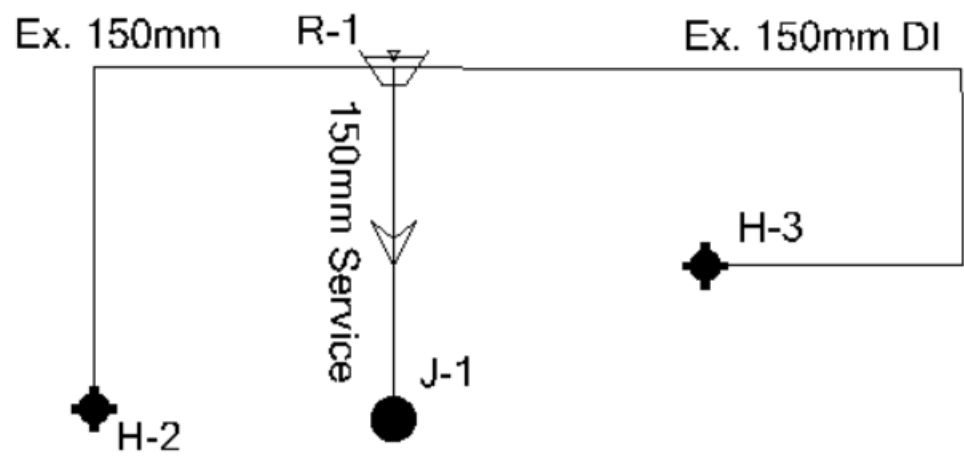

Active Scenario: Average Day - Existing Conditions

Label	Elevation (m)	Demand (L/min)	Pressure (psi)	Hydraulic Grade (m)
J-1	79.30	18.24	49.97	114.50

Active Scenario: Peak Hourly - Existing Conditions

Label	Elevation (m)	Demand (L/min)	Pressure (psi)	Hydraulic Grade (m)
J-1	79.30	100.31	41.59	108.60

Active Scenario: Max Day + Fire Flow - Existing Conditions

Label	Is Fire Flow Run Balanced?	Satisfies Fire Flow Constraints?	Fire Flow (Needed) (L/min)	Fire Flow (Available) (L/min)	Pressure (psi)	Elevation (m)	Demand (L/min)	Pressure (Residual Lower Limit) (psi)
H-2	True	False	8,000.00	4,451.31	37.76	82.00	0.00	20.00
H-3	True	False	8,000.00	7,706.61	40.60	80.00	0.00	20.00

Active Scenario: Max Day + Fire Flow - Existing Conditions

Label	Elevation (m)	Demand (L/min)	Pressure (psi)	Hydraulic Grade (m)
J-1	79.30	45.60	41.59	108.60

Francis Valenti

Subject: RE: Boundary Conditions Request - 1940 Carling Avenue

From: Dieme, Abi <Abibatou.Dieme@ottawa.ca>
Sent: January 6, 2023 1:21 PM
To: Nicholas Vachon <n.vachon@mcintoshperry.com>
Cc: Curtis Melanson <c.melanson@mcintoshperry.com>
Subject: RE: Boundary Conditions Request - 1940 Carling Avenue

Hi Curtis and Nicholas,

Please see below note from the Infrastructure and Water Services Department:

“A multi hydrant analysis was performed on the two hydrants identified by the consultant within 150 m of the subject site. The two hydrants can provide sufficient capacity for the fire demand of 133.3 L/s. These are for current conditions and are based on computer model simulation.

Disclaimer: The boundary condition information is based on current operation of the city water distribution system. The computer model simulation is based on the best information available at the time. The operation of the water distribution system can change on a regular basis, resulting in a variation in boundary conditions. The physical properties of watermains deteriorate over time, as such must be assumed in the absence of actual field test data. The variation in physical watermain properties can therefore alter the results of the computer model simulation.”

Please include this correspondence in your updated servicing report appendices for reference and consider comment 4 closed. Note that comment 6 still remains as per Ontario Building Code requirement.

Regards,
Abi

From: Dieme, Abi
Sent: December 22, 2022 10:44 AM
To: Nicholas Vachon <n.vachon@mcintoshperry.com>
Cc: Curtis Melanson <c.melanson@mcintoshperry.com>
Subject: RE: Boundary Conditions Request - 1940 Carling Avenue

Hi Nicholas,

I don't expect to receive it before January with the holidays. If this is the only item missing for resubmission, I would suggest that you resubmit with a note on my comment that the City is conducting a multi-hydrant analysis. When the results are provided I'll advise and confirm whether my comment is closed or not.

Regards,
Abi

From: Nicholas Vachon <n.vachon@mcintoshperry.com>
Sent: December 22, 2022 10:12 AM
To: Dieme, Abi <Abibatou.Dieme@ottawa.ca>
Cc: Curtis Melanson <c.melanson@mcintoshperry.com>
Subject: RE: Boundary Conditions Request - 1940 Carling Avenue

CAUTION: This email originated from an External Sender. Please do not click links or open attachments unless you recognize the source.

ATTENTION : Ce courriel provient d'un expéditeur externe. Ne cliquez sur aucun lien et n'ouvrez pas de pièce jointe, excepté si vous connaissez l'expéditeur.

Hey Abi,

Any update on the multi hydrant analysis?

Thanks,

Nicholas Vachon, EIT

Engineering Intern

T. 613.903.5805

n.vachon@mcintoshperry.com | www.mcintoshperry.com

McINTOSH PERRY

Turning Possibilities Into Reality

Confidentiality Notice – If this email wasn't intended for you, please return or delete it. Click [here](#) to read all of the legal language around this concept.



Platinum
member

From: Dieme, Abi <Abibatou.Dieme@ottawa.ca>
Sent: December 15, 2022 10:47 AM
To: Nicholas Vachon <n.vachon@mcintoshperry.com>
Cc: Curtis Melanson <c.melanson@mcintoshperry.com>
Subject: RE: Boundary Conditions Request - 1940 Carling Avenue

Hi Nicholas,

Thank you for your patience. I have met with IWSD and requested a multi-hydrant analysis to obtain more specific results as they've suggested. I will provide the results once I receive them.

Regards,
Abi

From: Nicholas Vachon <n.vachon@mcintoshperry.com>
Sent: December 13, 2022 11:09 AM
To: Dieme, Abi <Abibatou.Dieme@ottawa.ca>
Cc: Curtis Melanson <c.melanson@mcintoshperry.com>
Subject: RE: Boundary Conditions Request - 1940 Carling Avenue

CAUTION: This email originated from an External Sender. Please do not click links or open attachments unless you recognize the source.

ATTENTION : Ce courriel provient d'un expéditeur externe. Ne cliquez sur aucun lien et n'ouvrez pas de pièce jointe, excepté si vous connaissez l'expéditeur.

Hey Abi,

Have we heard anything from IWSD?

Regards,

Nicholas Vachon, EIT

Engineering Intern

T. 613.903.5805

n.vachon@mcintoshperry.com | www.mcintoshperry.com

McINTOSH PERRY

Turning Possibilities Into Reality

Confidentiality Notice – If this email wasn't intended for you, please return or delete it. Click [here](#) to read all of the legal language around this concept.



Platinum
member

From: Dieme, Abi <Abibatou.Dieme@ottawa.ca>

Sent: November 30, 2022 12:19 PM

To: Curtis Melanson <c.melanson@mcintoshperry.com>; Nicholas Vachon <n.vachon@mcintoshperry.com>

Subject: RE: Boundary Conditions Request - 1940 Carling Avenue

That's what the Infrastructure and Water Services Department provided at BC stage. The hydrant near Maple Crest is connected to the 152mm watermain you're proposing to connect to which is connected to the backbone and it didn't change the result. I'll follow up again with IWSD.

Attachments:

1940 Carling April 2021.pdf

Hi Braden,

Below is the BC.

The following are boundary conditions, HGL, for hydraulic analysis at 1940 Carling assumed to be connected to the 152 mm on Carling Ave (see attached PDF for details)

Minimum HGL = 108.6 m

Maximum HGL = 114.5 m

Available Fire Flow @ 20 psi = 66 L/s assuming a ground elevation of 81.4 m

These are for current conditions and are based on computer model simulation.

Disclaimer: The boundary condition information is based on current operation of the water distribution system. The computer model simulation is based on the best information available at the time. The operation of the water distribution system can change on a regular basis resulting in a variation in boundary conditions. The physical properties of watermain can change over time, as such must be assumed in the absence of actual field test data. The physical watermain properties can therefore alter the results of the computer model simulation.

Thanks,
Ahmed

Regards,
Abi

From: Curtis Melanson <c.melanson@mcintoshperry.com>

Sent: November 30, 2022 11:46 AM

To: Dieme, Abi <Abibatou.Dieme@ottawa.ca>; Nicholas Vachon <n.vachon@mcintoshperry.com>

Subject: RE: Boundary Conditions Request - 1940 Carling Avenue

CAUTION: This email originated from an External Sender. Please do not click links or open attachments unless you recognize the source.

ATTENTION : Ce courriel provient d'un expéditeur externe. Ne cliquez sur aucun lien et n'ouvrez pas de pièce jointe, excepté si vous connaissez l'expéditeur.

Hi Abi,

Does that mean for the 2 hydrants located at the corner of Dunlevie and Maplecrest the total flow available is 3,960 L/min from those two hydrants?

If so, I find that very unlikely considering the hydrant at Dunlevie is connected to the 150 off of the 610 backbone watermain.

Can you please review and let us know?

Thanks,

Curtis Melanson, C.E.T.

Practice Area Lead, Land Development

T. 613.714.4621 | C. 613.857.0784

c.melanson@mcintoshperry.com | www.mcintoshperry.com

McINTOSH PERRY

Turning Possibilities Into Reality

Confidentiality Notice – If this email wasn't intended for you, please return or delete it. Click [here](#) to read all of the legal language around this concept.



Platinum
member

From: Dieme, Abi <Abibatou.Dieme@ottawa.ca>
Sent: November 30, 2022 10:53 AM
To: Nicholas Vachon <n.vachon@mcintoshperry.com>
Cc: Curtis Melanson <c.melanson@mcintoshperry.com>
Subject: RE: Boundary Conditions Request - 1940 Carling Avenue

Hi Nicholas,

3,960 L/min is the total available flow in the system at 20psi.

Regards,
Abi

From: Nicholas Vachon <n.vachon@mcintoshperry.com>
Sent: November 30, 2022 10:03 AM
To: Dieme, Abi <Abibatou.Dieme@ottawa.ca>
Cc: Curtis Melanson <c.melanson@mcintoshperry.com>
Subject: RE: Boundary Conditions Request - 1940 Carling Avenue

CAUTION: This email originated from an External Sender. Please do not click links or open attachments unless you recognize the source.

ATTENTION : Ce courriel provient d'un expéditeur externe. Ne cliquez sur aucun lien et n'ouvrez pas de pièce jointe, excepté si vous connaissez l'expéditeur.

Hey Abi,

Going through the most recent comments and I just wanted some clarification on the below. Can you confirm if this applies to both hydrants individually or cumulatively.

“As a reminder, the available fire flow at 20 psi is 3,960 L/min. Measures should be provided to reduce the required fire flow or increase the available fire flow”

Regards,

Carling Avenue is a busy road with traffic count likely more than 30,000 vehicles per day. The median not being a raised median could still in winter cause difficulty for Fire Department to cross/operate. As such the fire hydrant on the opposite site (H094) should not be accounted for in the design for this proposed development.

As a reminder, the available fire flow at 20 psi is 3,960 L/min. Measures should be provided to reduce the required fire flow or increase the available fire flow.

Regards,
Abi

From: Nicholas Vachon <n.vachon@mcintoshperry.com>
Sent: August 02, 2022 9:56 AM
To: Dieme, Abi <Abibatou.Dieme@ottawa.ca>
Subject: RE: Boundary Conditions Request - 1940 Carling Avenue

CAUTION: This email originated from an External Sender. Please do not click links or open attachments unless you recognize the source.

ATTENTION : Ce courriel provient d'un expéditeur externe. Ne cliquez sur aucun lien et n'ouvrez pas de pièce jointe, excepté si vous connaissez l'expéditeur.

Hey Abi,

Yes, this is part of the comment we were looking at. I appreciate you forwarding.

Thanks,

From: Dieme, Abi <Abibatou.Dieme@ottawa.ca>
Sent: August 2, 2022 9:44 AM
To: Nicholas Vachon <n.vachon@mcintoshperry.com>
Subject: RE: Boundary Conditions Request - 1940 Carling Avenue

You don't often get email from abibatou.dieme@ottawa.ca. [Learn why this is important](#)

Hi Nicholas,

Ahmed has left the City since last August.

I suspect that this is related to my comment below:

“It is indicated in the boundary conditions that the available fire flow at 20 psi is 66 l/s (3960 l/min). The required fire flow for this proposed development is 13,000 l/min which is greater than the available fire flow. While there are three fire hydrants within 75m of the site with a capacity of 5,700l/min each, the available fire flow in the watermain system isn't sufficient to ensure fire protection for this development. 5,700 l/min is the capacity of each fire hydrant not the available fire flow.

Please provide alternatives to ensure adequate fire protection for the proposed development.”

It is expected from this comment that you provide alternatives to reduce the required fire flow (firewalls, new building components, etc) or increase the available fire flow (watermain upgrade).

I am not sure that modelling the fire hydrants separately would address the comment as the City's Infrastructure and Water Services Department has already provided the available fire flow (3960 l/min).

Regardless, I will forward your email to them and transfer any comment they may have.

Regards,
Abi

From: Nicholas Vachon <n.vachon@mcintoshperry.com>
Sent: July 28, 2022 3:15 PM
To: Dieme, Abi <Abibatou.Dieme@ottawa.ca>
Subject: FW: Boundary Conditions Request - 1940 Carling Avenue

CAUTION: This email originated from an External Sender. Please do not click links or open attachments unless you recognize the source.

ATTENTION : Ce courriel provient d'un expéditeur externe. Ne cliquez sur aucun lien et n'ouvrez pas de pièce jointe, excepté si vous connaissez l'expéditeur.

Hey Abi,

See below. I'm trying to reach out to Ahmed but keep getting a bounce back. Hoping you can help.

Thanks,

From: Nicholas Vachon
Sent: July 28, 2022 1:40 PM
To: Elsayed, Ahmed <ahmed.elsayed@ottawa.ca>
Subject: FW: Boundary Conditions Request - 1940 Carling Avenue

Hello Ahmed,

We sent the following boundary condition request to you back in April last year. As per the latest comments received I'm completing a water model of the nearby hydrants to confirm fire flow adequacy. Given the boundary condition you provided I've been able to model flows to two nearby hydrants. However, there is a hydrant across the street that we may require to achieve coverage.

Given the complexity of the connection and 3 separate but interconnected mains within Carling, would it be possible for you to provide me a boundary condition for that hydrant or even better provide me an acceptable flow rate to use for that hydrant (Similar to how you did in the original boundary condition request) for the purposes of my hydrant coverage calculation? I've attached a GeoOttawa sketch to illustrate.

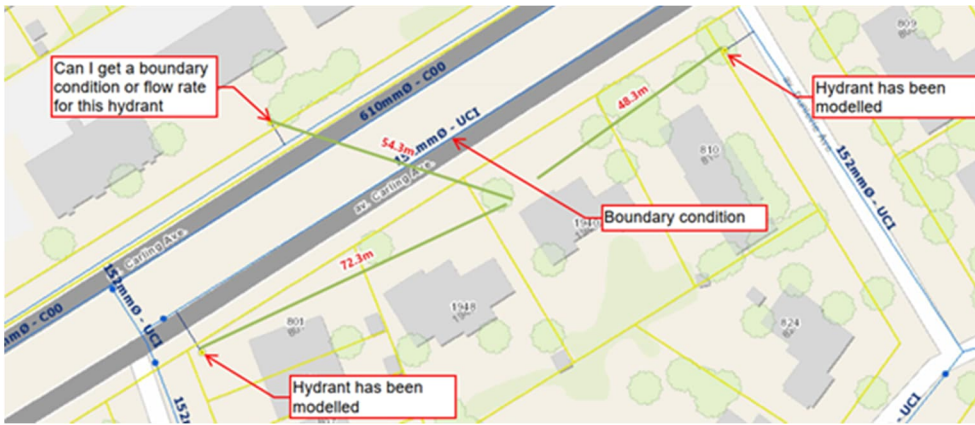

Thanks,

From: Braden Stuyt <B.Stuyt@McIntoshPerry.com>
 Sent: April 14, 2021 9:10 AM
 To: ahmed.elsayed@ottawa.ca
 Subject: Boundary Conditions Request - 1940 Carling Avenue

Hi Ahmed,

I have conducted the fire flow calculations with the information available and would like to request boundary conditions for the development located on 1940 Carling Avenue. I have attached our preliminary calculations and a location plan for reference. If you could please provide boundary conditions?

Please find the below fire flow to obtain boundary conditions.

Type of Development:	Residential
Location of Service:	1940 Carling Avenue
Amount of Fire Flow Required (FUS):	13,000 L/min
Site Area (ha):	0.15

If you require any further information or have any questions, please feel free to contact me.

Thank you,

Braden Stuyt

Engineering Intern - Land Development

115 Walgreen Road, Carp, ON K0A 1L0

T. 343.925.0163 | C. 343.364.3458

B.Stuyt@McIntoshPerry.com | www.mcintoshperry.com



Confidentiality Notice – If this email wasn't intended for you, please return or delete it. Click [here](#) to read all of the legal language around this concept.



Platinum member



,
This e-mail originates from the City of Ottawa e-mail system. Any distribution, use or copying of this e-mail or the information it contains by other than the intended recipient(s) is unauthorized. Thank you.

Le présent courriel a été expédié par le système de courriels de la Ville d'Ottawa. Toute distribution, utilisation ou reproduction du courriel ou des renseignements qui s'y trouvent par une personne autre que son destinataire prévu est interdite. Je vous remercie de votre collaboration.

,
This e-mail originates from the City of Ottawa e-mail system. Any distribution, use or copying of this e-mail or the information it contains by other than the intended recipient(s) is unauthorized. Thank you.

Le présent courriel a été expédié par le système de courriels de la Ville d'Ottawa. Toute distribution, utilisation ou reproduction du courriel ou des renseignements qui s'y trouvent par une personne autre que son destinataire prévu est interdite. Je vous remercie de votre collaboration.

,
This e-mail originates from the City of Ottawa e-mail system. Any distribution, use or copying of this e-mail or the information it contains by other than the intended recipient(s) is unauthorized. Thank you.

Le présent courriel a été expédié par le système de courriels de la Ville d'Ottawa. Toute distribution, utilisation ou reproduction du courriel ou des renseignements qui s'y trouvent par une personne autre que son destinataire prévu est interdite. Je vous remercie de votre collaboration.

,
This e-mail originates from the City of Ottawa e-mail system. Any distribution, use or copying of this e-mail or the information it contains by other than the intended recipient(s) is unauthorized. Thank you.

Le présent courriel a été expédié par le système de courriels de la Ville d'Ottawa. Toute distribution, utilisation ou reproduction du courriel ou des renseignements qui s'y trouvent par une personne autre que son destinataire prévu est interdite. Je vous remercie de votre collaboration.

,
This e-mail originates from the City of Ottawa e-mail system. Any distribution, use or copying of this e-mail or the information it contains by other than the intended recipient(s) is unauthorized. Thank you.

Le présent courriel a été expédié par le système de courriels de la Ville d'Ottawa. Toute distribution, utilisation ou reproduction du courriel ou des renseignements qui s'y trouvent par une personne autre que son destinataire prévu est interdite. Je vous remercie de votre collaboration.

'
'
This e-mail originates from the City of Ottawa e-mail system. Any distribution, use or copying of this e-mail or the information it contains by other than the intended recipient(s) is unauthorized. Thank you.

Le présent courriel a été expédié par le système de courriels de la Ville d'Ottawa. Toute distribution, utilisation ou reproduction du courriel ou des renseignements qui s'y trouvent par une personne autre que son destinataire prévu est interdite. Je vous remercie de votre collaboration.

'

APPENDIX D
SANITARY CALCULATIONS

McINTOSH PERRY

000-20-0079 - 1940 Carling Avenue - Sanitary Demands

Project:	1940 Carling Avenue		
Project No.:	000-20-0079		
Designed By:	FV		
Checked By:	NV		
Date:	July 29, 2022		
Ste Area	0.15	Gross ha	
Bachelor	33	1.40	Persons per unit
1 Bedroom	25	1.40	Persons per unit
2 Bedroom	6	2.10	Persons per unit
Total Population	94	Persons	
Amenity Space	645.00	m ²	

DESIGN PARAMETERS

Institutional/Commercial Peaking Factor	1.5	
Residential Peaking Factor	3.60	* Using Harmon Formula = $1+(14/(4+P^{0.5})) * 0.8$ where P = population in thousands, Harmon's Correction Factor = 0.8
Mannings coefficient (n)	0.013	
Demand (per capita)	280	L/day
Infiltration allowance	0.33	L/s/ha

EXTRANEIOUS FLOW ALLOWANCES

Infiltration / Inflow	Flow (L/s)
Dry	0.01
Wet	0.04
Total	0.05

AVERAGE DAILY DEMAND

DEMAND TYPE	AMOUNT	UNITS	POPULATION / AREA	Flow (L/s)
Residential	280	L/c/d	94	0.30
Industrial - Light**	35,000	L/gross ha/d		0
Industrial - Heavy**	55,000	L/gross ha/d		0
Commercial / Amenity	2,800	L/(1000m ² /d)	645.00	0.02
Hospital	900	L/(bed/day)		0
Schools	70	L/(Student/d)		0
Trailer Parks no Hook-Ups	340	L/(space/d)		0
Trailer Park with Hook-Ups	800	L/(space/d)		0
Campgrounds	225	L/(campsite/d)		0
Mobile Home Parks	1,000	L/(Space/d)		0
Motels	150	L/(bed-space/d)		0
Hotels	225	L/(bed-space/d)		0
Office	75	L/7.0m ² /d		0
Tourist Commercial	28,000	L/gross ha/d		0
Other Commercial	28,000	L/gross ha/d		0

AVERAGE RESIDENTIAL FLOW	0.30	L/s
PEAK RESIDENTIAL FLOW	1.10	L/s
AVERAGE ICI FLOW	0.02	L/s
PEAK INSTITUTIONAL/ COMMERCIAL FLOW	0.03	L/s
PEAK INDUSTRIAL FLOW	0.00	L/s
TOTAL PEAK ICI FLOW	0.03	L/s

TOTAL SANITARY DEMAND

TOTAL ESTIMATED AVERAGE DRY WEATHER FLOW	0.33	L/s
TOTAL ESTIMATED PEAK DRY WEATHER FLOW	1.14	L/s
TOTAL ESTIMATED PEAK WET WEATHER FLOW	1.18	L/s

Please note that the proposed site will have peak flows that are negligibly small in comparison to the capacity of the existing 225mm diameter sanitary main (19.66 L/s). Therefore, it is anticipated that the existing 225mm diameter concrete sanitary main within Carling Avenue has the capacity to accommodate the new flows.

SANITARY SEWER DESIGN SHEET

PROJECT: Residential
 LOCATION: 1940 Carling Avenue
 CLIENT: Domenic Santaguida



LOCATION				RESIDENTIAL									ICI AREAS			INFILTRATION ALLOWANCE			FLOW	SEWER DATA						
1	2	3	4	5	6	7	8	9	10	11	12	13	16	17	20	21	22	23	24	25	26	27	28	29	30	31
STREET	AREA ID	FROM MH	TO MH	UNIT TYPES				AREA (ha)	POPULATION		PEAK FACTOR	PEAK FLOW (L/s)	AREA (ha)		PEAK FLOW (L/s)	AREA (ha)		FLOW (L/s)	DESIGN FLOW (L/s)	CAPACITY (L/s)	LENGTH (m)	DIA (mm)	SLOPE (%)	VELOCITY (full) (m/s)	AVAILABLE CAPACITY	
				SF	SD/TH	APT-1BD	APT-2BD		IND	CUM			IND	CUM		IND	CUM								L/s	%
Carling Avenue		BLDG	Ex MH			58	6	0.15	93.8	94.0	3.60	1.10	0.06	0.00	0.03	0.15	0.15	0.05	1.18	87.74	10.54	250	2.00	1.731	86.56	98.66
Design Parameters:				Notes:									Designed: FV			No.		Revision			Date					
Residential																1.		Issued for Review			2021-09-17					
ICI Areas																2.		Revised per City Comments			2022-07-29					
SF	3.4	p/p/u																								
TH/SD	2.7	p/p/u	INST	28,000 L/Ha/day					1.5																	
APT-1BD	1.4	p/p/u	COM	28,000 L/Ha/day					1.5																	
APT-2BD	2.1	p/p/u	IND	35,000 L/Ha/day					MOE Chart																	
Other	60	p/p/Ha																								
				1. Mannings coefficient (n) = 0.013																						
				2. Demand (per capita): 280 L/day																						
				3. Infiltration allowance: 0.33 L/s/Ha																						
				4. Residential Peaking Factor: Harmon Formula = $1+(14/(4+P^{0.5})^*0.8)$ where P = population in thousands																						
													Checked: NV													
													Project No.: CP-20-0079													
																					Sheet No: 1 of 1					

Nicholas Vachon

From: Nicholas Vachon
Sent: May 27, 2021 3:40 PM
To: Nicholas Vachon
Subject: FW: Sanitary Flow - 1940 Carling Avenue

Nicholas Vachon, EIT

Engineering Intern

T. 613.903.5805

McINTOSH PERRY

Turning Possibilities Into Reality

From: Elsayed, Ahmed <ahmed.elsayed@ottawa.ca>
Sent: April 23, 2021 11:49 AM
To: Braden Stuyt <B.Stuyt@McIntoshPerry.com>
Subject: RE: Sanitary Flow - 1940 Carling Avenue

Hi Braden,

Below is the response as per the IPU.

First of all, I don't agree with their sanitary flow computation. Based on our revised guidelines (via the 2018 bulletin), I estimate the flow as follows:

- 71 units at 2.1 persons per unit (assuming 2 bedroom units) = 149 people
- Using 280 L/c/day = 0.48 L/s
- Using Harmon peak 4.0 with a 0.8 reduction factor = 1.55 L/s
- Using 0.33 L/s/ha for I/I = 0.05 L/s

Therefore the future flow is $1.55 + 0.05 = 1.6$ L/s

They should become familiar with how sanitary flows are computed in our guidelines.

Also, the pipe on Carling is a 225 mm diameter and not 300 mm.

This is a partially separated area (i.e foundation drains are connected to the sanitary) therefore during critical events the HGL can become elevated. I checked this section in the Flood Risk PCSWMM Model and found that the 100 year HGL still remains well below basements at this location (see pipe San26306 in figure below). As such, the additional 1.6 L/s flow will have no impact on the system.

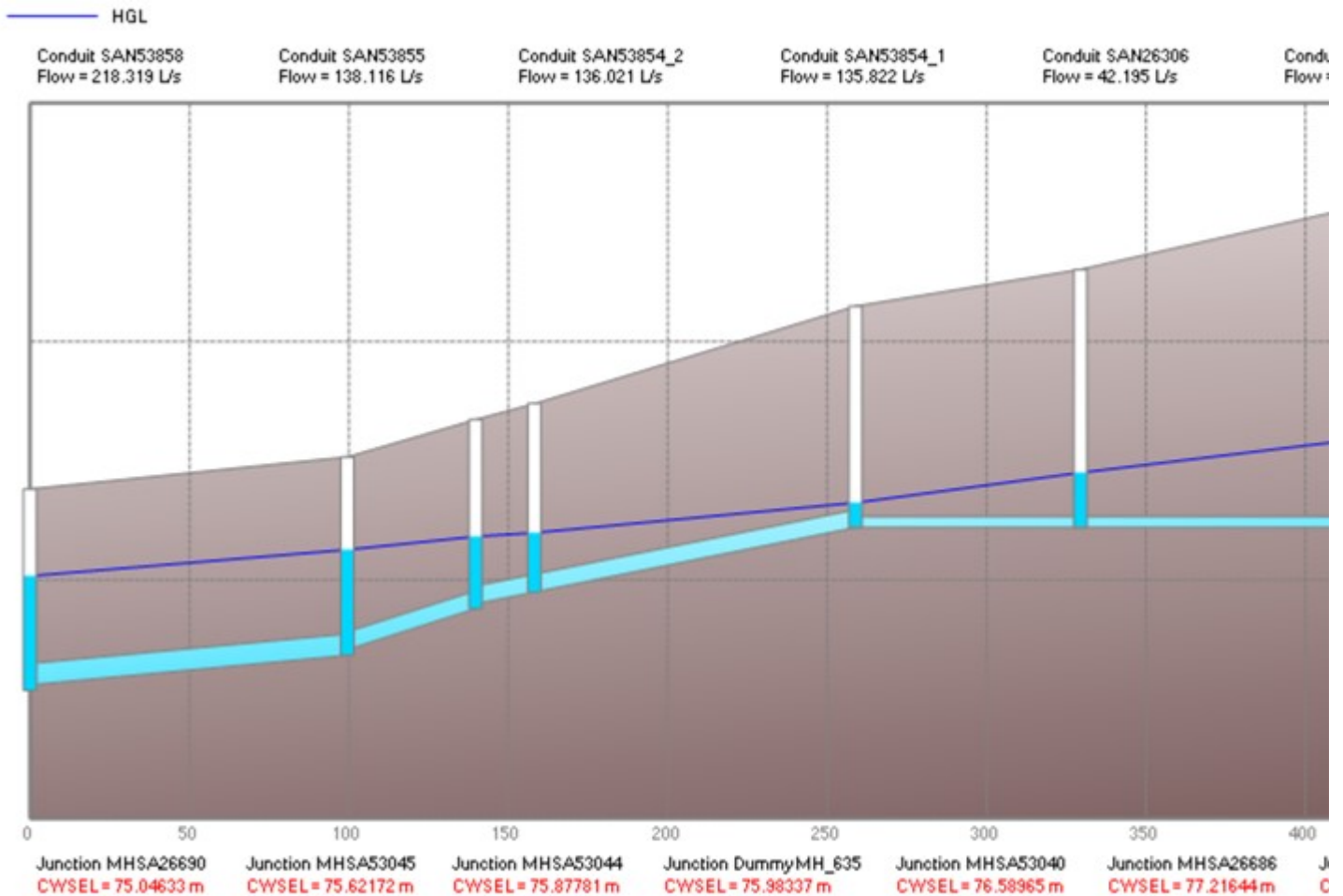

Please make sure to include the above as part of your servicing report.

Thanks,
Ahmed

From: Braden Stuyt <B.Stuyt@McIntoshPerry.com>
Sent: Wednesday, April 14, 2021 9:09 AM
To: Elsayed, Ahmed <ahmed.elsayed@ottawa.ca>
Subject: Sanitary Flow - 1940 Carling Avenue

CAUTION: This email originated from an External Sender. Please do not click links or open attachments unless you recognize the source.

ATTENTION : Ce courriel provient d'un expéditeur externe. Ne cliquez sur aucun lien et n'ouvrez pas de pièce jointe, excepté si vous connaissez l'expéditeur.

Hi Ahmed,

Please see attached sanitary calculation for the proposed apartment building at 1940 Carling Avenue. Can you review and let me know if there are any capacity concerns for the sanitary? I used the maximum unit count of 71 which was provided by the architect and can confirm it will not be higher than this regardless of any changes to the building.

If you have any questions just let me know.

Thanks,

Braden Stuyt

Engineering Intern - Land Development

115 Walgreen Road, Carp, ON K0A 1L0

T. 343.925.0163 | C. 343.364.3458

B.Stuyt@McIntoshPerry.com | www.mcintoshperry.com

McINTOSH PERRY

Confidentiality Notice – If this email wasn't intended for you, please return or delete it. Click [here](#) to read all of the legal language around this concept.



Platinum
member



This e-mail originates from the City of Ottawa e-mail system. Any distribution, use or copying of this e-mail or the information it contains by other than the intended recipient(s) is unauthorized. Thank you.

Le présent courriel a été expédié par le système de courriels de la Ville d'Ottawa. Toute distribution, utilisation ou reproduction du courriel ou des renseignements qui s'y trouvent par une personne autre que son destinataire prévu est interdite. Je vous remercie de votre collaboration.

APPENDIX E
PRE-DEVELOPMENT DRAINAGE PLAN

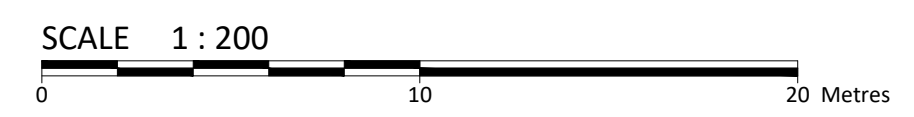
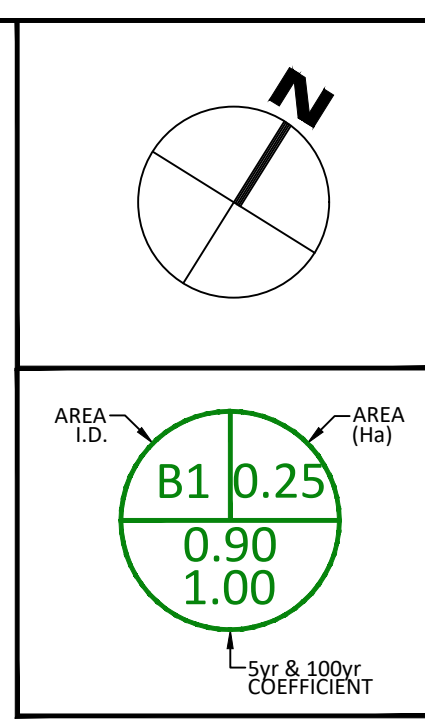
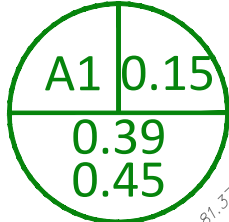
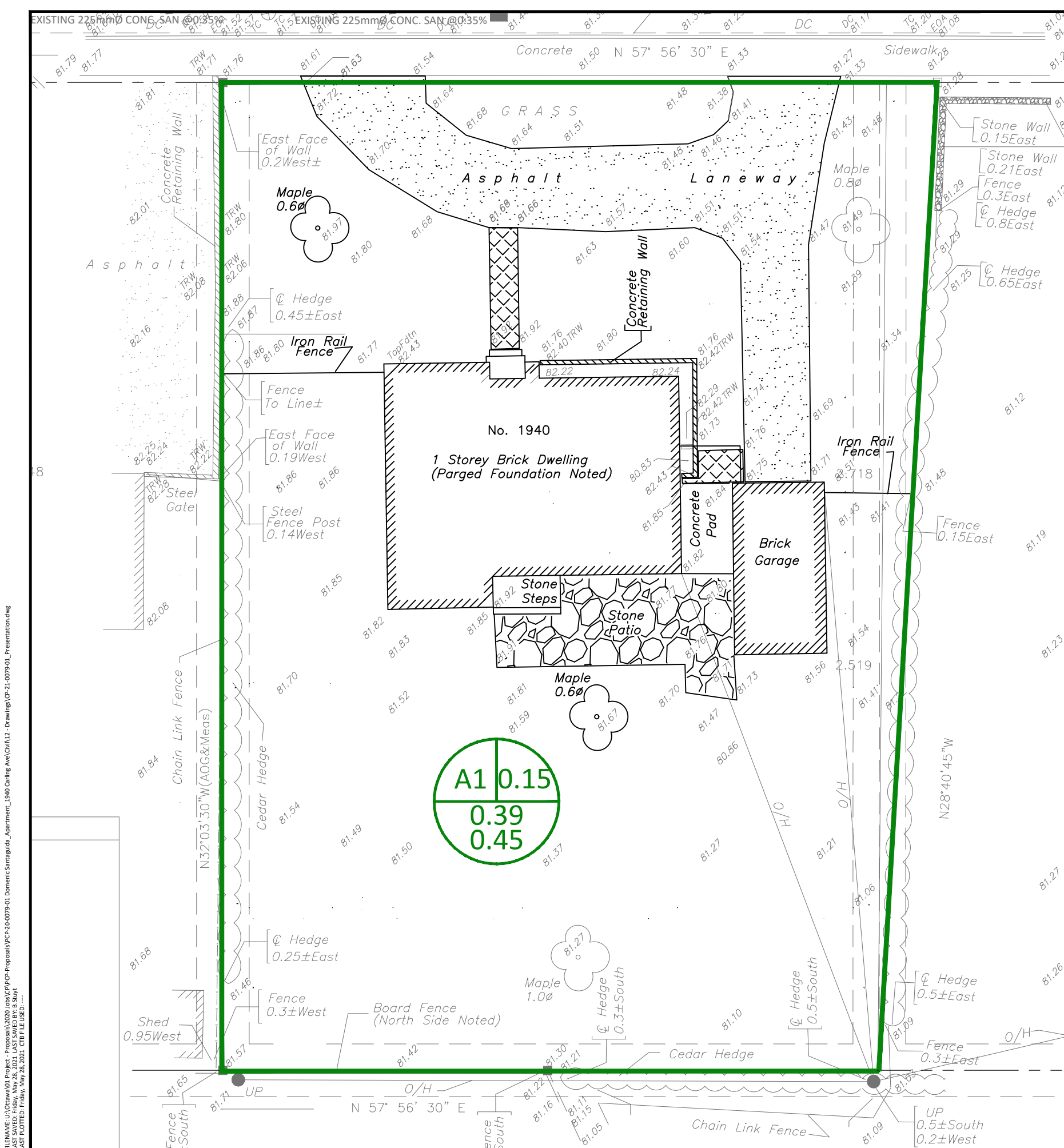

McINTOSH PERRY 115 Walgreen Road, RR3, Carp, ON K0A 1L0 Tel: 613-836-2184 Fax: 613-836-3742 www.mcintoshperry.com		Client: DOMENIC SANTAGUIDA	
		Project: 1940 CARLING AVENUE	
Drawing Title: PRE-DEVELOPMENT DRAINAGE AREA PLAN		Drawing Number: PRE	
Drawn by: B.G.S.	Checked By: T.D.F.	Revisions	
Scale: 1:200	Project Number: CP-20-0079	Date	

FILENAME: U:\Ottawa\01 Project - Proposals\2020 Jobs\CP\PCP-Proposals\CP-20-0079-01 Domenic Santaguida, Apartment_1940 Carling Ave\CWA12 - Drawings\CP-21-0079-01_Presentation.dwg
 LAST SAVED: Friday, May 28, 2021, 1:52:56 PM BY: B. Sturt
 LAST PLOTTED: Friday, May 28, 2021, 1:58:11 PM

APPENDIX F
POST-DEVELOPMENT DRAINAGE PLAN

FILENAME: U:\Ottawa\01 - Projects - Proposals\2020 jobs\CP\PCP-Proposals\PCP-20-0079-01 Domenic Santaguida - Apartment_1940 Carling Ave\Civil\12 - Drawings\CP-21-0079-01_Presentation.dwg
 LAST PLOTTED: Thursday, July 06, 2023 8:18 AM
 LAST PRINTED: Thursday, July 06, 2023 8:18 AM
 LAST FILED: Thursday, July 06, 2023 8:18 AM

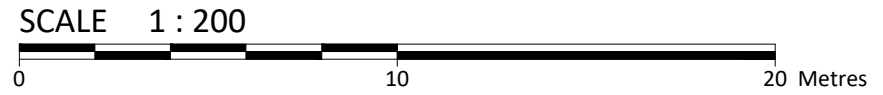
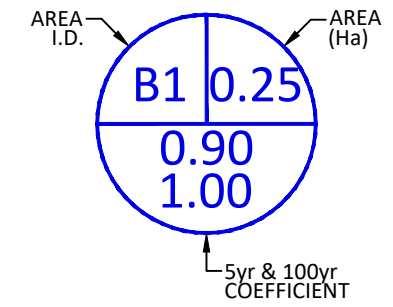
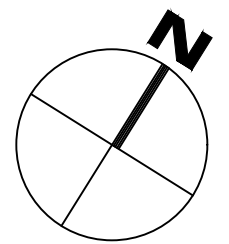
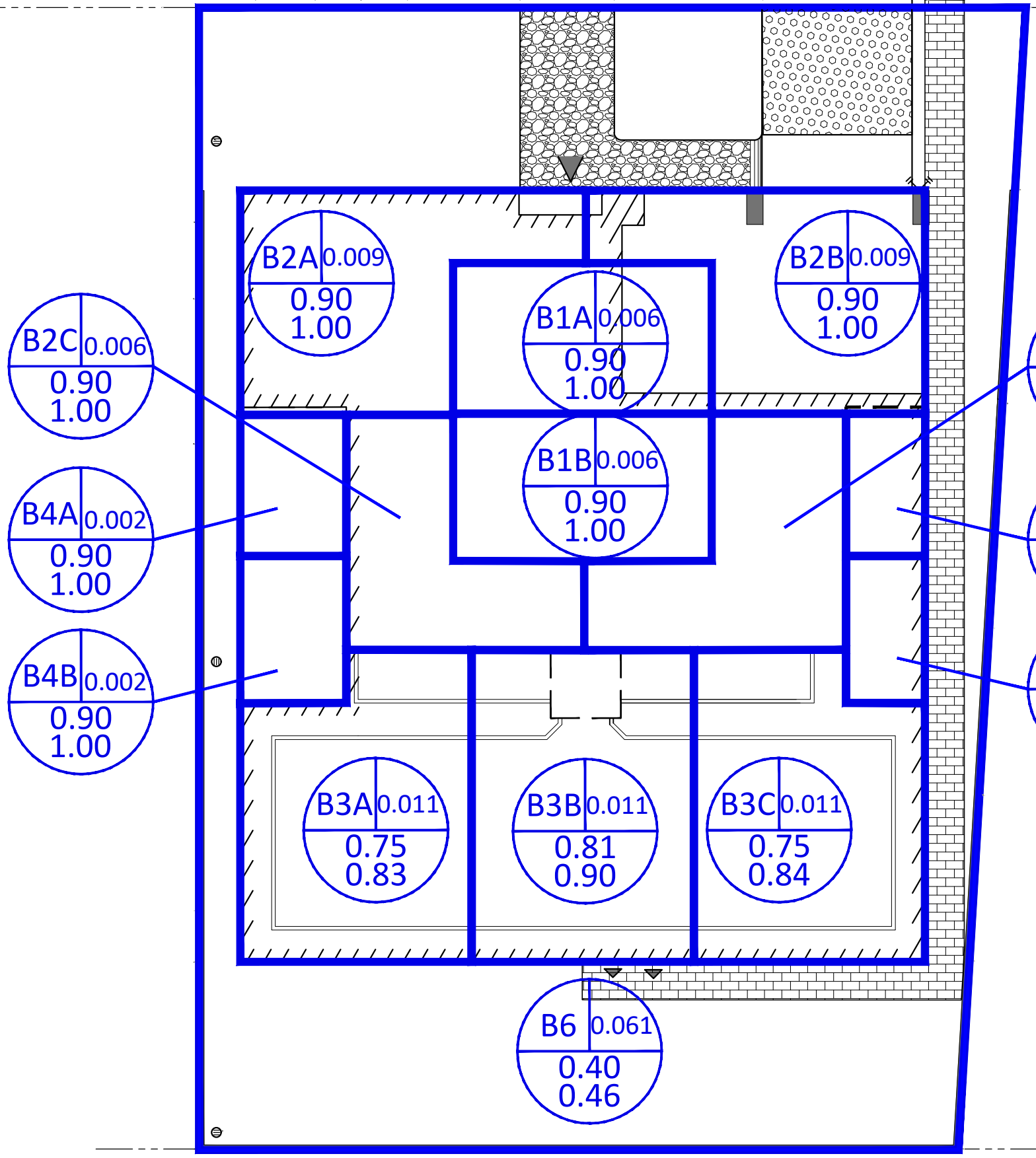

McINTOSH PERRY
 115 Walgreen Road, RR3, Carp, ON K0A 1L0
 Tel: 613-836-2184 Fax: 613-836-3742
 www.mcintoshperry.com

Client: DOMENIC SANTAGUIDA
 Project: 1940 CARLING AVENUE
 Drawing Title: POST-DEVELOPMENT DRAINAGE AREA PLAN

Drawn by: B.G.S.	Checked By: NBV	Drawing Number:	
Scale: 1:200	Project Number: CP-20-0079	POST	
No.	Revisions	Date	

#18662

APPENDIX G
STORMWATER MANAGEMENT CALCULATIONS

McINTOSH PERRY

CP-20-0079 - 1940 Carling Ave - Runoff Calculations

Pre-Development Runoff Coefficient

Drainage Area	Area (ha)	Impervious	C	Gravel	C	Pervious	C	C _{AVG} 5-Year	C _{AVG} 100-Year
		Area (m ²)		Area (m ²)		Area (m ²)			
A1	0.145	386.63	0.90	0.00	0.60	1,066.37	0.20	0.39	0.45

Pre-Development Runoff Calculations

Drainage Area	Area (ha)	C 2/5-Year	C 100-Year	Tc (min)	I (mm/hr)			Q (L/s)		
					2-Year	5-Year	100-Year	2-Year	5-Year	100-Year
A1	0.145	0.39	0.45	10	76.8	104.2	178.6	11.98	16.26	32.43
Total	0.145							11.98	16.26	32.43

Post-Development Runoff Coefficient

Drainage Area	Area (ha)	Impervious	C	Gravel	C	Pervious	C	C _{AVG} 2/5-Year	C _{AVG} 100-Year	
		Area (m ²)		Area (m ²)		Area (m ²)				
B1A	0.006	62.46	0.90	0.00	0.60	0.00	0.20	0.90	1.00	Restricted
B1B	0.006	60.81	0.90	0.00	0.60	0.00	0.20	0.90	1.00	Restricted
B2A	0.009	92.05	0.90	0.00	0.60	0.00	0.20	0.90	1.00	Restricted
B2B	0.009	88.73	0.90	0.00	0.60	0.00	0.20	0.90	1.00	Restricted
B2C	0.006	59.03	0.90	0.00	0.60	0.00	0.20	0.90	1.00	Restricted
B2D	0.007	70.54	0.90	0.00	0.60	0.00	0.20	0.90	1.00	Restricted
B3A	0.011	83.17	0.90	0.00	0.60	23.57	0.20	0.75	0.83	Restricted
B3B	0.011	97.08	0.90	0.00	0.60	14.11	0.20	0.81	0.90	Restricted
B3C	0.011	85.74	0.90	0.00	0.60	23.14	0.20	0.75	0.84	Restricted
B4A	0.002	24.00	0.90	0.00	0.60	0.00	0.20	0.90	1.00	Restricted
B4B	0.002	24.99	0.90	0.00	0.60	0.00	0.20	0.90	1.00	Restricted
B5A	0.002	18.84	0.90	0.00	0.60	0.00	0.20	0.90	1.00	Restricted
B5B	0.002	18.55	0.90	0.00	0.60	0.00	0.20	0.90	1.00	Restricted
B6	0.061	170.52	0.90	0.00	0.60	435.67	0.20	0.40	0.46	Unrestricted

Post-Development Runoff Calculations

Drainage Area	Area (ha)	C 2/5-Year	C 100-Year	Tc (min)	I (mm/hr)			Q (L/s)			
					2-Year	5-Year	100-Year	2-Year	5-Year	100-Year	
B1A	0.01	0.90	1.00	10	76.8	104.2	178.6	1.20	1.63	3.10	Restricted
B1B	0.01	0.90	1.00	10	76.8	104.2	178.6	1.17	1.59	3.02	Restricted
B2A	0.01	0.90	1.00	10	76.8	104.2	178.6	1.77	2.40	4.57	Restricted
B2B	0.01	0.90	1.00	10	76.8	104.2	178.6	1.71	2.31	4.40	Restricted
B2C	0.01	0.90	1.00	10	76.8	104.2	178.6	1.13	1.54	2.93	Restricted
B2D	0.01	0.90	1.00	10	76.8	104.2	178.6	1.36	1.84	3.50	Restricted
B3A	0.01	0.75	0.83	10	76.8	104.2	178.6	1.70	2.30	4.42	Restricted
B3B	0.01	0.81	0.90	10	76.8	104.2	178.6	1.93	2.61	4.99	Restricted
B3C	0.01	0.75	0.84	10	76.8	104.2	178.6	1.75	2.37	4.54	Restricted
B4A	0.002	0.90	1.00	10	76.8	104.2	178.6	0.46	0.63	1.19	Restricted
B4B	0.002	0.90	1.00	10	76.8	104.2	178.6	0.48	0.65	1.24	Restricted
B5A	0.002	0.90	1.00	10	76.8	104.2	178.6	0.36	0.49	0.94	Restricted
B5B	0.002	0.90	1.00	10	76.8	104.2	178.6	0.36	0.48	0.92	Restricted
B6	0.06	0.40	0.46	10	76.8	104.2	178.6	5.14	6.97	13.87	Unrestricted
Total	0.145							20.50	27.81	53.64	

Required Restricted Flow

Drainage Area	Area (ha)	C 2-Year	Tc (min)	I (mm/hr)	Q (L/s)
				2-Year	2-Year
A1	0.145	0.39	10	76.8	11.98

McINTOSH PERRY

Post-Development Restricted Runoff Calculations

Drainage Area	Unrestricted Flow (L/s)			Restricted Flow (L/s)			Storage Required (m ³)			Storage Provided (m ³)		
	2-Year	5-Year	100-Year	2-Year	5-Year	100-Year	2-Year	5-Year	100-Year	2-Year	5-Year	100-Year
B1A	1.20	1.63	3.10	0.32	0.32	0.32	0.60	0.95	2.39	0.61	1.03	2.59
B1B	1.17	1.59	3.02	0.32	0.32	0.32	0.57	0.92	2.30	0.60	1.01	2.30
B2A	1.77	2.40	4.57	0.32	0.32	0.32	1.09	1.69	4.03	1.20	1.82	4.05
B2B	1.71	2.31	4.40	0.32	0.32	0.32	1.03	1.60	3.83	1.10	1.72	3.94
B2C	1.13	1.54	2.93	0.32	0.32	0.32	0.54	0.88	2.21	0.67	1.05	2.30
B2D	1.36	1.84	3.50	0.32	0.32	0.32	0.72	1.15	2.82	0.92	1.39	2.82
B3A	1.70	2.30	4.42	0.32	0.32	0.32	1.03	1.59	3.85	1.12	1.71	3.89
B3B	1.93	2.61	4.99	0.32	0.32	0.32	1.24	1.90	4.53	1.43	2.12	4.55
B3C	1.75	2.37	4.54	0.32	0.32	0.32	1.07	1.65	4.00	1.12	1.72	4.23
B4A	0.46	0.63	1.19	0.32	0.32	0.32	0.09	0.19	0.58	0.17	0.26	0.65
B4B	0.48	0.65	1.24	0.32	0.32	0.32	0.10	0.20	0.62	0.18	0.28	0.73
B5A	0.36	0.49	0.94	0.25	0.32	0.32	0.07	0.11	0.39	0.14	0.20	0.46
B5B	0.36	0.48	0.92	0.25	0.32	0.32	0.06	0.10	0.38	0.11	0.17	0.43
B6	5.14	6.97	13.87	5.14	6.97	13.87						
Total	20.50	27.81	53.64	9.11	11.07	17.97	8.21	12.92	31.92	9.37	14.45	32.92

McINTOSH PERRY

CP-20-0079 - 1940 Carling Ave - Runoff Calculations

3 of 42

Storage Requirements for Area B1A

2-Year Storm Event

Tc (min)	I (mm/hr)	Runoff (L/s)	Allowable Outflow (L/s)	Runoff to be Stored (L/s)	Storage Required (m ³)
10	76.8	1.20	0.32	0.88	0.53
15	61.8	0.97	0.32	0.65	0.58
20	52.0	0.81	0.32	0.50	0.60
25	45.2	0.71	0.32	0.39	0.59
30	40.0	0.63	0.32	0.31	0.56
35	36.1	0.56	0.32	0.25	0.52
40	32.9	0.51	0.32	0.20	0.48
45	30.2	0.47	0.32	0.16	0.42
50	28.0	0.44	0.32	0.12	0.37
55	26.2	0.41	0.32	0.09	0.31

Maximum Storage Required 2-Year (m³) = 0.60

5-Year Storm Event

Tc (min)	I (mm/hr)	Runoff (L/s)	Allowable Outflow (L/s)	Runoff to be Stored (L/s)	Storage Required (m ³)
10	104.2	1.63	0.32	1.31	0.79
15	83.6	1.31	0.32	0.99	0.89
20	70.3	1.10	0.32	0.78	0.94
25	60.9	0.95	0.32	0.64	0.95
30	53.9	0.84	0.32	0.53	0.95
35	48.5	0.76	0.32	0.44	0.93
40	44.18	0.69	0.32	0.38	0.90
45	40.63	0.63	0.32	0.32	0.86
50	37.65	0.59	0.32	0.27	0.82
55	35.12	0.55	0.32	0.23	0.77

Maximum Storage Required 5-Year (m³) = 0.95

100-Year Storm Event

Tc (min)	I (mm/hr)	Runoff (L/s)	Allowable Outflow (L/s)	Runoff to be Stored (L/s)	Storage Required (m ³)
10	178.6	3.10	0.32	2.79	1.67
15	142.9	2.48	0.32	2.17	1.95
20	120.0	2.08	0.32	1.77	2.12
25	103.8	1.80	0.32	1.49	2.23
30	91.9	1.60	0.32	1.28	2.30
35	82.6	1.43	0.32	1.12	2.35
40	75.1	1.30	0.32	0.99	2.37
45	69.1	1.20	0.32	0.88	2.39
50	64.0	1.11	0.32	0.80	2.39
55	59.6	1.04	0.32	0.72	2.38

Maximum Storage Required 100-Year (m³) = 2.39

McINTOSH PERRY

Storage Occupied In Area B1A

2-Year Storm Event

Roof Storage			
Location	Area	Depth	Volume (m ³)*
B1A	35.55	0.045	0.61
		Total	0.61

2-Year Storm Event

Storage Available (m ³) =	0.61
Storage Required (m ³) =	0.60

5-Year Storm Event

Roof Storage			
Location	Area	Depth	Volume (m ³)*
B1A	46.72	0.055	1.03
		Total	1.03

5-Year Storm Event

Storage Available (m ³) =	1.03
Storage Required (m ³) =	0.95

100-Year Storm Event

Roof Storage			
Location	Area	Depth	Volume (m ³)*
B1A	52.78	0.085	2.59
		Total	2.59

100-Year Storm Event

Storage Available (m ³) =	2.59
Storage Required (m ³) =	2.39

* Available Storage calculated in AutoCAD with assumed 1% roof slope. See storage summary below

Ponding Depth (m)	Area (m ²)	Incremental Volume (m ³)	Cumulative Volume (m ³)
0.01	2.13	N/A	0.00
0.02	9.03	0.06	0.06
0.03	18.40	0.14	0.19
0.04	29.41	0.24	0.43
0.05	41.68	0.36	0.79
0.06	51.75	0.47	1.26
0.07	53.80	0.53	1.78
0.08	53.82	0.54	2.32
0.09	53.83	0.54	2.86
0.1	53.84	0.54	3.40
0.11	53.85	0.54	3.94
0.12	53.86	0.54	4.48
0.13	53.87	0.54	5.01
0.14	53.88	0.54	5.55
0.15	53.90	0.54	6.09

McINTOSH PERRY

Roof Drain Flow (B1A)

Roof Drains Summary			
Type of Control Device	Watts Drainage - Accutrol Weir		
Roof Drain Position	Closed		
Number of Roof Drains	1		
	2-Year	5-Year	100-Year
Rooftop Storage Available(m ³)	0.61	1.03	2.59
Rooftop Storage Required(m ³)	0.60	0.95	2.39
Storage Depth (m)	0.045	0.055	0.085
Flow (Per Roof Drain) (L/s)	0.32	0.32	0.32
Total Flow (L/s)	0.32	0.32	0.32

Flow Rate Vs. Build-Up (Individual Drain)	
Depth (mm)	Flow (L/s)
0	0.00
5	0.00
10	0.06
15	0.13
20	0.19
25	0.25
30	0.32
35	0.32
40	0.32
45	0.32
50	0.32
55	0.32
60	0.32
65	0.32
70	0.32
75	0.32
80	0.32
85	0.32
90	0.32
95	0.32
100	0.32
105	0.32
110	0.32
115	0.32
120	0.32
125	0.32
130	0.32
135	0.32
140	0.32
145	0.32
150	0.32

Roof Drain Flow			
	Flow (l/s)	Storage Depth (mm)	Drains Flow (l/s)
	0.13	15	0.13
	0.19	20	0.19
	0.25	25	0.25
	0.32	30	0.32
	0.32	35	0.32
	0.32	40	0.32
2-Year	0.32	45	0.32
	0.32	50	0.32
5-Year	0.32	55	0.32
	0.32	60	0.32
	0.32	65	0.32
	0.32	70	0.32
	0.32	75	0.32
	0.32	80	0.32
100-Year	0.32	85	0.32
	0.32	90	0.32
	0.32	95	0.32
	0.32	100	0.32
	0.32	105	0.32
	0.32	110	0.32
	0.32	115	0.32
	0.32	120	0.32
	0.32	125	0.32
	0.32	130	0.32
	0.32	135	0.32
	0.32	140	0.32
	0.32	145	0.32
	0.32	150	0.32

Note: The flow leaving through a restricted roof drain is based on flow vs. head information

McINTOSH PERRY

CP-20-0079 - 1940 Carling Ave - Runoff Calculations

6 of 42

Storage Requirements for Area B1B

2-Year Storm Event

Tc (min)	I (mm/hr)	Runoff (L/s)	Allowable	Runoff to	Storage
			Outflow (L/s)	be Stored (L/s)	Required (m ³)
10	76.8	1.17	0.32	0.85	0.51
15	61.8	0.94	0.32	0.62	0.56
20	52.0	0.79	0.32	0.48	0.57
25	45.2	0.69	0.32	0.37	0.56
30	40.0	0.61	0.32	0.29	0.53
35	36.1	0.55	0.32	0.23	0.49
40	32.9	0.50	0.32	0.18	0.44
45	30.2	0.46	0.32	0.14	0.39
50	28.0	0.43	0.32	0.11	0.33
55	26.2	0.40	0.32	0.08	0.27

Maximum Storage Required 2-Year (m³) = 0.57

5-Year Storm Event

Tc (min)	I (mm/hr)	Runoff (L/s)	Allowable	Runoff to	Storage
			Outflow (L/s)	be Stored (L/s)	Required (m ³)
10	104.2	1.59	0.32	1.27	0.76
15	83.6	1.27	0.32	0.96	0.86
20	70.3	1.07	0.32	0.75	0.90
25	60.9	0.93	0.32	0.61	0.92
30	53.9	0.82	0.32	0.51	0.91
35	48.5	0.74	0.32	0.42	0.89
40	44.18	0.67	0.32	0.36	0.86
45	40.63	0.62	0.32	0.30	0.82
50	37.65	0.57	0.32	0.26	0.77
55	35.12	0.53	0.32	0.22	0.72

Maximum Storage Required 5-Year (m³) = 0.92

100-Year Storm Event

Tc (min)	I (mm/hr)	Runoff (L/s)	Allowable	Runoff to	Storage
			Outflow (L/s)	be Stored (L/s)	Required (m ³)
10	178.6	3.02	0.32	2.70	1.62
15	142.9	2.42	0.32	2.10	1.89
20	120.0	2.03	0.32	1.71	2.05
25	103.8	1.76	0.32	1.44	2.16
30	91.9	1.55	0.32	1.24	2.23
35	82.6	1.40	0.32	1.08	2.27
40	75.1	1.27	0.32	0.95	2.29
45	69.1	1.17	0.32	0.85	2.30
50	64.0	1.08	0.32	0.77	2.30
55	59.6	1.01	0.32	0.69	2.29

Maximum Storage Required 100-Year (m³) = 2.30

McINTOSH PERRY

Storage Occupied In Area B1B

2-Year Storm Event

Roof Storage			
Location	Area	Depth	Volume (m ³)*
B1B	34.93	0.045	0.60
Total			0.60

2-Year Storm Event

Storage Available (m ³) =	0.60
Storage Required (m ³) =	0.57

5-Year Storm Event

Roof Storage			
Location	Area	Depth	Volume (m ³)*
B1B	46.19	0.055	1.01
Total			1.01

5-Year Storm Event

Storage Available (m ³) =	1.01
Storage Required (m ³) =	0.92

100-Year Storm Event

Roof Storage			
Location	Area	Depth	Volume (m ³)*
B1B	53.54	0.080	2.30
Total			2.30

100-Year Storm Event

Storage Available (m ³) =	2.30
Storage Required (m ³) =	2.30

* Available Storage calculated in AutoCAD with assumed 1% roof slope. See storage summary below

Ponding Depth (m)	Area (m ²)	Incremental Volume (m ³)	Cumulative Volume (m ³)
0.01	2.44	N/A	0.00
0.02	8.96	0.06	0.06
0.03	17.98	0.13	0.19
0.04	28.82	0.23	0.43
0.05	41.03	0.35	0.77
0.06	51.35	0.46	1.24
0.07	53.52	0.52	1.76
0.08	53.54	0.54	2.30
0.09	53.55	0.54	2.83
0.1	53.57	0.54	3.37
0.11	53.59	0.54	3.90
0.12	53.62	0.54	4.44
0.13	53.64	0.54	4.98
0.14	53.66	0.54	5.51
0.15	53.68	0.54	6.05

McINTOSH PERRY

Roof Drain Flow (B1B)

Roof Drains Summary			
Type of Control Device	Watts Drainage - Accutrol Weir		
Roof Drain Position	Closed		
Number of Roof Drains	1		
	2-Year	5-Year	100-Year
Rooftop Storage Available(m ³)	0.60	1.01	2.30
Rooftop Storage Required(m ³)	0.57	0.92	2.30
Storage Depth (m)	0.045	0.055	0.080
Flow (Per Roof Drain) (L/s)	0.32	0.32	0.32
Total Flow (L/s)	0.32	0.32	0.32

Flow Rate Vs. Build-Up (Individual Drain)	
Depth (mm)	Flow (L/s)
0	0.00
5	0.00
10	0.06
15	0.13
20	0.19
25	0.25
30	0.32
35	0.32
40	0.32
45	0.32
50	0.32
55	0.32
60	0.32
65	0.32
70	0.32
75	0.32
80	0.32
85	0.32
90	0.32
95	0.32
100	0.32
105	0.32
110	0.32
115	0.32
120	0.32
125	0.32
130	0.32
135	0.32
140	0.32
145	0.32
150	0.32

Roof Drain Flow			
	Flow (l/s)	Storage Depth (mm)	Drains Flow (l/s)
	0.13	15	0.13
	0.19	20	0.19
	0.25	25	0.25
	0.32	30	0.32
	0.32	35	0.32
	0.32	40	0.32
2-Year	0.32	45	0.32
	0.32	50	0.32
5-Year	0.32	55	0.32
	0.32	60	0.32
	0.32	65	0.32
	0.32	70	0.32
	0.32	75	0.32
100-Year	0.32	80	0.32
	0.32	85	0.32
	0.32	90	0.32
	0.32	95	0.32
	0.32	100	0.32
	0.32	105	0.32
	0.32	110	0.32
	0.32	115	0.32
	0.32	120	0.32
	0.32	125	0.32
	0.32	130	0.32
	0.32	135	0.32
	0.32	140	0.32
	0.32	145	0.32
	0.32	150	0.32

Note: The flow leaving through a restricted roof drain is based on flow vs. head information

McINTOSH PERRY

CP-20-0079 - 1940 Carling Ave - Runoff Calculations

9 of 42

Storage Requirements for Area B2A

2-Year Storm Event

Tc (min)	I (mm/hr)	Runoff (L/s)	Allowable	Runoff to	Storage
			Outflow (L/s)	be Stored (L/s)	Required (m ³)
10	76.8	1.77	0.32	1.45	0.87
15	61.8	1.42	0.32	1.11	1.00
20	52.0	1.20	0.32	0.88	1.06
25	45.2	1.04	0.32	0.72	1.09
30	40.0	0.92	0.32	0.61	1.09
35	36.1	0.83	0.32	0.52	1.08
40	32.9	0.76	0.32	0.44	1.06
45	30.2	0.70	0.32	0.38	1.03
50	28.0	0.65	0.32	0.33	0.99
55	26.2	0.60	0.32	0.29	0.95

Maximum Storage Required 2-Year (m³) = 1.09

5-Year Storm Event

Tc (min)	I (mm/hr)	Runoff (L/s)	Allowable	Runoff to	Storage
			Outflow (L/s)	be Stored (L/s)	Required (m ³)
10	104.2	2.40	0.32	2.08	1.25
15	83.6	1.92	0.32	1.61	1.45
20	70.3	1.62	0.32	1.30	1.56
25	60.9	1.40	0.32	1.09	1.63
30	53.9	1.24	0.32	0.93	1.67
35	48.5	1.12	0.32	0.80	1.68
40	44.18	1.02	0.32	0.70	1.69
45	40.63	0.94	0.32	0.62	1.67
50	37.65	0.87	0.32	0.55	1.66
55	35.12	0.81	0.32	0.49	1.63

Maximum Storage Required 5-Year (m³) = 1.69

100-Year Storm Event

Tc (min)	I (mm/hr)	Runoff (L/s)	Allowable	Runoff to	Storage
			Outflow (L/s)	be Stored (L/s)	Required (m ³)
30	91.9	2.35	0.32	2.04	3.66
35	82.6	2.11	0.32	1.80	3.78
40	75.1	1.92	0.32	1.61	3.86
45	69.1	1.77	0.32	1.45	3.92
50	64.0	1.64	0.32	1.32	3.96
55	59.6	1.53	0.32	1.21	3.99
60	55.9	1.43	0.32	1.11	4.01
65	52.6	1.35	0.32	1.03	4.02
70	49.8	1.27	0.32	0.96	4.03
75	47.3	1.21	0.32	0.89	4.02

Maximum Storage Required 100-Year (m³) = 4.03

McINTOSH PERRY

Storage Occupied In Area B2A

2-Year Storm Event

Roof Storage			
Location	Area	Depth	Volume (m ³)*
B2A	57.76	0.055	1.20
		Total	1.20

2-Year Storm Event

Storage Available (m ³) =	1.20
Storage Required (m ³) =	1.09

5-Year Storm Event

Roof Storage			
Location	Area	Depth	Volume (m ³)*
B2A	66.79	0.065	1.82
		Total	1.82

5-Year Storm Event

Storage Available (m ³) =	1.82
Storage Required (m ³) =	1.69

100-Year Storm Event

Roof Storage			
Location	Area	Depth	Volume (m ³)*
B2A	80.75	0.095	4.05
		Total	4.05

100-Year Storm Event

Storage Available (m ³) =	4.05
Storage Required (m ³) =	4.03

* Available Storage calculated in AutoCAD with assumed 1% roof slope. See storage summary below

Ponding Depth (m)	Area (m ²)	Incremental Volume (m ³)	Cumulative Volume (m ³)
0.01	2.29	N/A	0.00
0.02	8.78	0.06	0.06
0.03	19.80	0.14	0.20
0.04	35.10	0.27	0.47
0.05	51.64	0.43	0.91
0.06	63.87	0.58	1.48
0.07	69.71	0.67	2.15
0.08	74.77	0.72	2.87
0.09	79.03	0.77	3.64
0.1	82.47	0.81	4.45
0.11	83.38	0.83	5.28
0.12	83.41	0.83	6.11
0.13	83.44	0.83	6.95
0.14	83.47	0.83	7.78
0.15	83.50	0.83	8.62

McINTOSH PERRY

Storage Requirements for Area B2A

Roof Drains Summary			
Type of Control Device	Watts Drainage - Accutrol Weir		
Roof Drain Position	Closed		
Number of Roof Drains	1		
	2-Year	5-Year	100-Year
Rooftop Storage Available(m ³)	1.20	1.82	4.05
Rooftop Storage Required(m ³)	1.09	1.69	4.03
Storage Depth (m)	0.055	0.065	0.095
Flow (Per Roof Drain) (L/s)	0.32	0.32	0.32
Total Flow (L/s)	0.32	0.32	0.32

Flow Rate Vs. Build-Up (Individual Drain)	
Depth (mm)	Flow (L/s)
0	0.00
5	0.00
10	0.06
15	0.13
20	0.19
25	0.25
30	0.32
35	0.32
40	0.32
45	0.32
50	0.32
55	0.32
60	0.32
65	0.32
70	0.32
75	0.32
80	0.32
85	0.32
90	0.32
95	0.32
100	0.32
105	0.32
110	0.32
115	0.32
120	0.32
125	0.32
130	0.32
135	0.32
140	0.32
145	0.32
150	0.32

Roof Drain Flow			
	Flow (l/s)	Storage Depth (mm)	Drains Flow (l/s)
	0.13	15	0.13
	0.19	20	0.19
	0.25	25	0.25
	0.32	30	0.32
	0.32	35	0.32
	0.32	40	0.32
	0.32	45	0.32
	0.32	50	0.32
2-Year	0.32	55	0.32
	0.32	60	0.32
5-Year	0.32	65	0.32
	0.32	70	0.32
	0.32	75	0.32
	0.32	80	0.32
	0.32	85	0.32
	0.32	90	0.32
100-Year	0.32	95	0.32
	0.32	100	0.32
	0.32	105	0.32
	0.32	110	0.32
	0.32	115	0.32
	0.32	120	0.32
	0.32	125	0.32
	0.32	130	0.32
	0.32	135	0.32
	0.32	140	0.32
	0.32	145	0.32
	0.32	150	0.32

Note: The flow leaving through a restricted roof drain is based on flow vs. head information

McINTOSH PERRY

CP-20-0079 - 1940 Carling Ave - Runoff Calculations

12 of 42

Storage Requirements for Area B2B

2-Year Storm Event

Tc (min)	I (mm/hr)	Runoff (L/s)	Allowable	Runoff to	Storage
			Outflow (L/s)	be Stored (L/s)	Required (m ³)
10	76.8	1.71	0.32	1.39	0.83
15	61.8	1.37	0.32	1.06	0.95
20	52.0	1.16	0.32	0.84	1.01
25	45.2	1.00	0.32	0.69	1.03
30	40.0	0.89	0.32	0.57	1.03
35	36.1	0.80	0.32	0.49	1.02
40	32.9	0.73	0.32	0.41	0.99
45	30.2	0.67	0.32	0.36	0.96
50	28.0	0.62	0.32	0.31	0.92
55	26.2	0.58	0.32	0.27	0.88

Maximum Storage Required 2-Year (m³) = 1.03

5-Year Storm Event

Tc (min)	I (mm/hr)	Runoff (L/s)	Allowable	Runoff to	Storage
			Outflow (L/s)	be Stored (L/s)	Required (m ³)
10	104.2	2.31	0.32	2.00	1.20
15	83.6	1.85	0.32	1.54	1.39
20	70.3	1.56	0.32	1.24	1.49
25	60.9	1.35	0.32	1.04	1.55
30	53.9	1.20	0.32	0.88	1.59
35	48.5	1.08	0.32	0.76	1.60
40	44.18	0.98	0.32	0.67	1.60
45	40.63	0.90	0.32	0.59	1.58
50	37.65	0.84	0.32	0.52	1.56
55	35.12	0.78	0.32	0.46	1.53

Maximum Storage Required 5-Year (m³) = 1.60

100-Year Storm Event

Tc (min)	I (mm/hr)	Runoff (L/s)	Allowable	Runoff to	Storage
			Outflow (L/s)	be Stored (L/s)	Required (m ³)
40	75.1	1.85	0.32	1.54	3.69
45	69.1	1.70	0.32	1.39	3.75
50	64.0	1.58	0.32	1.26	3.79
55	59.6	1.47	0.32	1.16	3.81
60	55.9	1.38	0.32	1.06	3.83
65	52.6	1.30	0.32	0.98	3.83
70	49.8	1.23	0.32	0.91	3.83
75	47.3	1.17	0.32	0.85	3.83
80	45.0	1.11	0.32	0.79	3.81
85	43.0	1.06	0.32	0.74	3.79

Maximum Storage Required 100-Year (m³) = 3.83

McINTOSH PERRY

Storage Occupied In Area B2B

2-Year Storm Event

Roof Storage			
Location	Area	Depth	Volume (m ³)*
B2B	56.19	0.055	1.10
Total			1.10

2-Year Storm Event

Storage Available (m ³) =	1.10
Storage Required (m ³) =	1.03

5-Year Storm Event

Roof Storage			
Location	Area	Depth	Volume (m ³)*
B2B	66.72	0.065	1.72
Total			1.72

5-Year Storm Event

Storage Available (m ³) =	1.72
Storage Required (m ³) =	1.60

100-Year Storm Event

Roof Storage			
Location	Area	Depth	Volume (m ³)*
B2B	80.75	0.095	3.94
Total			3.94

100-Year Storm Event

Storage Available (m ³) =	3.94
Storage Required (m ³) =	3.83

* Available Storage calculated in AutoCAD with assumed 1% roof slope. See storage summary below

Ponding Depth (m)	Area (m ²)	Incremental Volume (m ³)	Cumulative Volume (m ³)
0.01	2.10	N/A	0.00
0.02	7.77	0.05	0.05
0.03	17.50	0.13	0.18
0.04	31.11	0.24	0.42
0.05	48.59	0.40	0.82
0.06	63.79	0.56	1.38
0.07	69.64	0.67	2.05
0.08	74.71	0.72	2.77
0.09	79.01	0.77	3.54
0.1	82.49	0.81	4.34
0.11	83.55	0.83	5.17
0.12	83.58	0.84	6.01
0.13	83.61	0.84	6.85
0.14	83.64	0.84	7.68
0.15	83.67	0.84	8.52

McINTOSH PERRY

Storage Requirements for Area B2B

Roof Drains Summary			
Type of Control Device	Watts Drainage - Accutrol Weir		
Roof Drain Position	Closed		
Number of Roof Drains	1		
	2-Year	5-Year	100-Year
Rooftop Storage Available(m ³)	1.10	1.72	3.94
Rooftop Storage Required(m ³)	1.03	1.60	3.83
Storage Depth (m)	0.055	0.065	0.095
Flow (Per Roof Drain) (L/s)	0.32	0.32	0.32
Total Flow (L/s)	0.32	0.32	0.32

Flow Rate Vs. Build-Up (Individual Drain)	
Depth (mm)	Flow (L/s)
0	0.00
5	0.00
10	0.06
15	0.13
20	0.19
25	0.25
30	0.32
35	0.32
40	0.32
45	0.32
50	0.32
55	0.32
60	0.32
65	0.32
70	0.32
75	0.32
80	0.32
85	0.32
90	0.32
95	0.32
100	0.32
105	0.32
110	0.32
115	0.32
120	0.32
125	0.32
130	0.32
135	0.32
140	0.32
145	0.32
150	0.32

Roof Drain Flow			
	Flow (l/s)	Storage Depth (mm)	Drains Flow (l/s)
	0.13	15	0.13
	0.19	20	0.19
	0.25	25	0.25
	0.32	30	0.32
	0.32	35	0.32
	0.32	40	0.32
	0.32	45	0.32
	0.32	50	0.32
2-Year	0.32	55	0.32
	0.32	60	0.32
5-Year	0.32	65	0.32
	0.32	70	0.32
	0.32	75	0.32
	0.32	80	0.32
	0.32	85	0.32
	0.32	90	0.32
100-Year	0.32	95	0.32
	0.32	100	0.32
	0.32	105	0.32
	0.32	110	0.32
	0.32	115	0.32
	0.32	120	0.32
	0.32	125	0.32
	0.32	130	0.32
	0.32	135	0.32
	0.32	140	0.32
	0.32	145	0.32
	0.32	150	0.32

Note: The flow leaving through a restricted roof drain is based on flow vs. head information

McINTOSH PERRY

CP-20-0079 - 1940 Carling Ave - Runoff Calculations

15 of 42

Storage Requirements for Area B2C

2-Year Storm Event

Tc (min)	I (mm/hr)	Runoff (L/s)	Allowable	Runoff to	Storage
			Outflow (L/s)	be Stored (L/s)	Required (m ³)
10	76.8	1.13	0.32	0.82	0.49
15	61.8	0.91	0.32	0.60	0.54
20	52.0	0.77	0.32	0.45	0.54
25	45.2	0.67	0.32	0.35	0.53
30	40.0	0.59	0.32	0.28	0.50
35	36.1	0.53	0.32	0.22	0.46
40	32.9	0.49	0.32	0.17	0.41
45	30.2	0.45	0.32	0.13	0.35
50	28.0	0.41	0.32	0.10	0.30
55	26.2	0.39	0.32	0.07	0.23

Maximum Storage Required 2-Year (m³) = 0.54

5-Year Storm Event

Tc (min)	I (mm/hr)	Runoff (L/s)	Allowable	Runoff to	Storage
			Outflow (L/s)	be Stored (L/s)	Required (m ³)
10	104.2	1.54	0.32	1.22	0.73
15	83.6	1.23	0.32	0.92	0.83
20	70.3	1.04	0.32	0.72	0.87
25	60.9	0.90	0.32	0.58	0.88
30	53.9	0.80	0.32	0.48	0.87
35	48.5	0.72	0.32	0.40	0.84
40	44.18	0.65	0.32	0.34	0.81
45	40.63	0.60	0.32	0.28	0.77
50	37.65	0.56	0.32	0.24	0.72
55	35.12	0.52	0.32	0.20	0.67

Maximum Storage Required 5-Year (m³) = 0.88

100-Year Storm Event

Tc (min)	I (mm/hr)	Runoff (L/s)	Allowable	Runoff to	Storage
			Outflow (L/s)	be Stored (L/s)	Required (m ³)
10	178.6	2.93	0.32	2.61	1.57
15	142.9	2.34	0.32	2.03	1.83
20	120.0	1.97	0.32	1.65	1.98
25	103.8	1.70	0.32	1.39	2.08
30	91.9	1.51	0.32	1.19	2.15
35	82.6	1.36	0.32	1.04	2.18
40	75.1	1.23	0.32	0.92	2.20
45	69.1	1.13	0.32	0.82	2.21
50	64.0	1.05	0.32	0.73	2.20
55	59.6	0.98	0.32	0.66	2.19

Maximum Storage Required 100-Year (m³) = 2.21

McINTOSH PERRY

Storage Occupied In Area B2C

2-Year Storm Event

Roof Storage			
Location	Area	Depth	Volume (m ³)*
B2C	33.57	0.045	0.67
		Total	0.67

2-Year Storm Event

Storage Available (m ³) =	0.67
Storage Required (m ³) =	0.54

5-Year Storm Event

Roof Storage			
Location	Area	Depth	Volume (m ³)*
B2C	42.13	0.055	1.05
		Total	1.05

5-Year Storm Event

Storage Available (m ³) =	1.05
Storage Required (m ³) =	0.88

100-Year Storm Event

Roof Storage			
Location	Area	Depth	Volume (m ³)*
B2C	56.31	0.080	2.30
		Total	2.30

100-Year Storm Event

Storage Available (m ³) =	2.30
Storage Required (m ³) =	2.21

* Available Storage calculated in AutoCAD with assumed 1% roof slope. See storage summary below

Ponding Depth (m)	Area (m ²)	Incremental Volume (m ³)	Cumulative Volume (m ³)
0.01	4.02	0.02	0.02
0.02	11.32	0.08	0.10
0.03	20.07	0.16	0.25
0.04	29.18	0.25	0.50
0.05	37.96	0.34	0.84
0.06	46.30	0.42	1.26
0.07	53.49	0.50	1.76
0.08	56.31	0.55	2.30
0.09	56.33	0.56	2.87
0.1	56.36	0.56	3.43
0.11	56.38	0.56	4.00
0.12	56.40	0.56	4.56
0.13	56.43	0.56	5.12
0.14	56.46	0.56	5.69
0.15	56.48	0.56	6.25

McINTOSH PERRY

Storage Requirements for Area B2C

Roof Drains Summary			
Type of Control Device	Watts Drainage - Accutrol Weir		
Roof Drain Position	Closed		
Number of Roof Drains	1		
	2-Year	5-Year	100-Year
Rooftop Storage Available(m ³)	0.67	1.05	2.30
Rooftop Storage Required(m ³)	0.54	0.88	2.21
Storage Depth (m)	0.045	0.055	0.080
Flow (Per Roof Drain) (L/s)	0.32	0.32	0.32
Total Flow (L/s)	0.32	0.32	0.32

Flow Rate Vs. Build-Up (Individual Drain)	
Depth (mm)	Flow (L/s)
0	0.00
5	0.00
10	0.06
15	0.13
20	0.19
25	0.25
30	0.32
35	0.32
40	0.32
45	0.32
50	0.32
55	0.32
60	0.32
65	0.32
70	0.32
75	0.32
80	0.32
85	0.32
90	0.32
95	0.32
100	0.32
105	0.32
110	0.32
115	0.32
120	0.32
125	0.32
130	0.32
135	0.32
140	0.32
145	0.32
150	0.32

Roof Drain Flow			
	Flow (l/s)	Storage Depth (mm)	Drains Flow (l/s)
	0.13	15	0.13
	0.19	20	0.19
	0.25	25	0.25
	0.32	30	0.32
	0.32	35	0.32
	0.32	40	0.32
2-Year	0.32	45	0.32
	0.32	50	0.32
5-Year	0.32	55	0.32
	0.32	60	0.32
	0.32	65	0.32
	0.32	70	0.32
	0.32	75	0.32
100-Year	0.32	80	0.32
	0.32	85	0.32
	0.32	90	0.32
	0.32	95	0.32
	0.32	100	0.32
	0.32	105	0.32
	0.32	110	0.32
	0.32	115	0.32
	0.32	120	0.32
	0.32	125	0.32
	0.32	130	0.32
	0.32	135	0.32
	0.32	140	0.32
	0.32	145	0.32
	0.32	150	0.32

Note: The flow leaving through a restricted roof drain is based on flow vs. head information

McINTOSH PERRY

CP-20-0079 - 1940 Carling Ave - Runoff Calculations

18 of 42

Storage Requirements for Area B2D

2-Year Storm Event

Tc (min)	I (mm/hr)	Runoff (L/s)	Allowable	Runoff to	Storage
			Outflow (L/s)	be Stored (L/s)	Required (m ³)
10	76.8	1.36	0.32	1.04	0.62
15	61.8	1.09	0.32	0.77	0.70
20	52.0	0.92	0.32	0.60	0.72
25	45.2	0.80	0.32	0.48	0.72
30	40.0	0.71	0.32	0.39	0.70
35	36.1	0.64	0.32	0.32	0.67
40	32.9	0.58	0.32	0.26	0.63
45	30.2	0.53	0.32	0.22	0.59
50	28.0	0.49	0.32	0.18	0.54
55	26.2	0.46	0.32	0.15	0.48

Maximum Storage Required 2-Year (m³) = 0.72

5-Year Storm Event

Tc (min)	I (mm/hr)	Runoff (L/s)	Allowable	Runoff to	Storage
			Outflow (L/s)	be Stored (L/s)	Required (m ³)
10	104.2	1.84	0.32	1.52	0.91
15	83.6	1.47	0.32	1.16	1.04
20	70.3	1.24	0.32	0.92	1.11
25	60.9	1.07	0.32	0.76	1.14
30	53.9	0.95	0.32	0.64	1.15
35	48.5	0.86	0.32	0.54	1.14
40	44.18	0.78	0.32	0.46	1.11
45	40.63	0.72	0.32	0.40	1.08
50	37.65	0.66	0.32	0.35	1.05
55	35.12	0.62	0.32	0.30	1.00

Maximum Storage Required 5-Year (m³) = 1.15

100-Year Storm Event

Tc (min)	I (mm/hr)	Runoff (L/s)	Allowable	Runoff to	Storage
			Outflow (L/s)	be Stored (L/s)	Required (m ³)
30	91.9	1.80	0.32	1.49	2.67
35	82.6	1.62	0.32	1.30	2.74
40	75.1	1.47	0.32	1.16	2.78
45	69.1	1.35	0.32	1.04	2.80
50	64.0	1.25	0.32	0.94	2.82
55	59.6	1.17	0.32	0.85	2.82
60	55.9	1.10	0.32	0.78	2.81
65	52.6	1.03	0.32	0.72	2.80
70	49.8	0.98	0.32	0.66	2.78
75	47.3	0.93	0.32	0.61	2.75

Maximum Storage Required 100-Year (m³) = 2.82

McINTOSH PERRY

Storage Occupied In Area B2D

2-Year Storm Event

Roof Storage			
Location	Area	Depth	Volume (m ³)*
B2D	41.83	0.055	0.92
Total			0.92

2-Year Storm Event

Storage Available (m ³) =	0.92
Storage Required (m ³) =	0.72

5-Year Storm Event

Roof Storage			
Location	Area	Depth	Volume (m ³)*
B2D	50.78	0.065	1.39
Total			1.39

5-Year Storm Event

Storage Available (m ³) =	1.39
Storage Required (m ³) =	1.15

100-Year Storm Event

Roof Storage			
Location	Area	Depth	Volume (m ³)*
B2D	60.89	0.090	2.82
Total			2.82

100-Year Storm Event

Storage Available (m ³) =	2.82
Storage Required (m ³) =	2.82

* Available Storage calculated in AutoCAD with assumed 1% roof slope. See storage summary below

Ponding Depth (m)	Area (m ²)	Incremental Volume (m ³)	Cumulative Volume (m ³)
0.01	1.87	N/A	0.00
0.02	7.43	0.05	0.05
0.03	16.71	0.12	0.17
0.04	27.27	0.22	0.39
0.05	37.17	0.32	0.71
0.06	46.48	0.42	1.13
0.07	55.07	0.51	1.64
0.08	60.79	0.58	2.21
0.09	60.89	0.61	2.82
0.1	60.91	0.61	3.43
0.11	60.94	0.61	4.04
0.12	60.96	0.61	4.65
0.13	60.99	0.61	5.26
0.14	61.01	0.61	5.87
0.15	61.04	0.61	6.48

McINTOSH PERRY

Storage Requirements for Area B2D

Roof Drains Summary			
Type of Control Device	Watts Drainage - Accutrol Weir		
Roof Drain Position	Closed		
Number of Roof Drains	1		
	2-Year	5-Year	100-Year
Rooftop Storage Available(m ³)	0.92	1.39	2.82
Rooftop Storage Required(m ³)	0.72	1.15	2.82
Storage Depth (m)	0.055	0.065	0.090
Flow (Per Roof Drain) (L/s)	0.32	0.32	0.32
Total Flow (L/s)	0.32	0.32	0.32

Flow Rate Vs. Build-Up (Individual Drain)	
Depth (mm)	Flow (L/s)
0	0.00
5	0.00
10	0.06
15	0.13
20	0.19
25	0.25
30	0.32
35	0.32
40	0.32
45	0.32
50	0.32
55	0.32
60	0.32
65	0.32
70	0.32
75	0.32
80	0.32
85	0.32
90	0.32
95	0.32
100	0.32
105	0.32
110	0.32
115	0.32
120	0.32
125	0.32
130	0.32
135	0.32
140	0.32
145	0.32
150	0.32

Roof Drain Flow			
	Flow (l/s)	Storage Depth (mm)	Drains Flow (l/s)
	0.13	15	0.13
	0.19	20	0.19
	0.25	25	0.25
	0.32	30	0.32
	0.32	35	0.32
	0.32	40	0.32
	0.32	45	0.32
	0.32	50	0.32
2-Year	0.32	55	0.32
	0.32	60	0.32
5-Year	0.32	65	0.32
	0.32	70	0.32
	0.32	75	0.32
	0.32	80	0.32
	0.32	85	0.32
100-Year	0.32	90	0.32
	0.32	95	0.32
	0.32	100	0.32
	0.32	105	0.32
	0.32	110	0.32
	0.32	115	0.32
	0.32	120	0.32
	0.32	125	0.32
	0.32	130	0.32
	0.32	135	0.32
	0.32	140	0.32
	0.32	145	0.32
	0.32	150	0.32

Note: The flow leaving through a restricted roof drain is based on flow vs. head information

McINTOSH PERRY

CP-20-0079 - 1940 Carling Ave - Runoff Calculations

21 of 42

Storage Requirements for Area B3A

2-Year Storm Event

Tc (min)	I (mm/hr)	Runoff (L/s)	Allowable	Runoff to	Storage
			Outflow (L/s)	be Stored (L/s)	Required (m ³)
10	76.8	1.70	0.32	1.38	0.83
15	61.8	1.37	0.32	1.05	0.95
20	52.0	1.15	0.32	0.84	1.00
25	45.2	1.00	0.32	0.68	1.03
30	40.0	0.89	0.32	0.57	1.03
35	36.1	0.80	0.32	0.48	1.01
40	32.9	0.73	0.32	0.41	0.99
45	30.2	0.67	0.32	0.35	0.95
50	28.0	0.62	0.32	0.30	0.91
55	26.2	0.58	0.32	0.26	0.87

Maximum Storage Required 2-Year (m³) = 1.03

5-Year Storm Event

Tc (min)	I (mm/hr)	Runoff (L/s)	Allowable	Runoff to	Storage
			Outflow (L/s)	be Stored (L/s)	Required (m ³)
10	104.2	2.30	0.32	1.99	1.19
15	83.6	1.85	0.32	1.53	1.38
20	70.3	1.55	0.32	1.24	1.49
25	60.9	1.35	0.32	1.03	1.55
30	53.9	1.19	0.32	0.88	1.58
35	48.5	1.07	0.32	0.76	1.59
40	44.18	0.98	0.32	0.66	1.59
45	40.63	0.90	0.32	0.58	1.57
50	37.65	0.83	0.32	0.52	1.55
55	35.12	0.78	0.32	0.46	1.52

Maximum Storage Required 5-Year (m³) = 1.59

100-Year Storm Event

Tc (min)	I (mm/hr)	Runoff (L/s)	Allowable	Runoff to	Storage
			Outflow (L/s)	be Stored (L/s)	Required (m ³)
25	103.8	2.57	0.32	2.26	3.38
30	91.9	2.27	0.32	1.96	3.53
35	82.6	2.04	0.32	1.73	3.63
40	75.1	1.86	0.32	1.55	3.71
45	69.1	1.71	0.32	1.39	3.76
50	64.0	1.58	0.32	1.27	3.80
55	59.6	1.48	0.32	1.16	3.83
60	55.9	1.38	0.32	1.07	3.85
65	52.6	1.30	0.32	0.99	3.85
70	49.8	1.23	0.32	0.92	3.85

Maximum Storage Required 100-Year (m³) = 3.85

McINTOSH PERRY

Storage Occupied In Area B3A

2-Year Storm Event

Roof Storage			
Location	Area	Depth	Volume (m ³)*
B3A	56.10	0.055	1.12
		Total	1.12

2-Year Storm Event

Storage Available (m ³) =	1.12
Storage Required (m ³) =	1.03

5-Year Storm Event

Roof Storage			
Location	Area	Depth	Volume (m ³)*
B3A	62.36	0.065	1.71
		Total	1.71

5-Year Storm Event

Storage Available (m ³) =	1.71
Storage Required (m ³) =	1.59

100-Year Storm Event

Roof Storage			
Location	Area	Depth	Volume (m ³)*
B3A	62.43	0.100	3.89
		Total	3.89

100-Year Storm Event

Storage Available (m ³) =	3.89
Storage Required (m ³) =	3.85

* Available Storage calculated in AutoCAD with assumed 1% roof slope. See storage summary below

Ponding Depth (m)	Area (m ²)	Incremental Volume (m ³)	Cumulative Volume (m ³)
0.01	2.08	N/A	0.00
0.02	7.95	0.05	0.05
0.03	17.94	0.13	0.18
0.04	31.90	0.25	0.43
0.05	49.84	0.41	0.84
0.06	62.35	0.56	1.40
0.07	62.37	0.62	2.02
0.08	62.39	0.62	2.65
0.09	62.41	0.62	3.27
0.1	62.43	0.62	3.89
0.11	62.45	0.62	4.52
0.12	62.48	0.62	5.14
0.13	62.50	0.62	5.77
0.14	62.52	0.63	6.39
0.15	62.54	0.63	7.02

McINTOSH PERRY

Storage Requirements for Area B3A

Roof Drains Summary			
Type of Control Device	Watts Drainage - Accutrol Weir		
Roof Drain Position	Closed		
Number of Roof Drains	1		
	2-Year	5-Year	100-Year
Rooftop Storage Available(m ³)	1.12	1.71	3.89
Rooftop Storage Required(m ³)	1.03	1.59	3.85
Storage Depth (m)	0.055	0.065	0.100
Flow (Per Roof Drain) (L/s)	0.32	0.32	0.32
Total Flow (L/s)	0.32	0.32	0.32

Flow Rate Vs. Build-Up (Individual Drain)	
Depth (mm)	Flow (L/s)
0	0.00
5	0.00
10	0.06
15	0.13
20	0.19
25	0.25
30	0.32
35	0.32
40	0.32
45	0.32
50	0.32
55	0.32
60	0.32
65	0.32
70	0.32
75	0.32
80	0.32
85	0.32
90	0.32
95	0.32
100	0.32
105	0.32
110	0.32
115	0.32
120	0.32
125	0.32
130	0.32
135	0.32
140	0.32
145	0.32
150	0.32

Roof Drain Flow			
	Flow (l/s)	Storage Depth (mm)	Drains Flow (l/s)
	0.13	15	0.13
	0.19	20	0.19
	0.25	25	0.25
	0.32	30	0.32
	0.32	35	0.32
	0.32	40	0.32
	0.32	45	0.32
	0.32	50	0.32
2-Year	0.32	55	0.32
	0.32	60	0.32
5-Year	0.32	65	0.32
	0.32	70	0.32
	0.32	75	0.32
	0.32	80	0.32
	0.32	85	0.32
	0.32	90	0.32
	0.32	95	0.32
100-Year	0.32	100	0.32
	0.32	105	0.32
	0.32	110	0.32
	0.32	115	0.32
	0.32	120	0.32
	0.32	125	0.32
	0.32	130	0.32
	0.32	135	0.32
	0.32	140	0.32
	0.32	145	0.32
	0.32	150	0.32

Note: The flow leaving through a restricted roof drain is based on flow vs. head information

McINTOSH PERRY

CP-20-0079 - 1940 Carling Ave - Runoff Calculations

24 of 42

Storage Requirements for Area B3B

2-Year Storm Event

Tc (min)	I (mm/hr)	Runoff (L/s)	Allowable	Runoff to	Storage
			Outflow (L/s)	be Stored (L/s)	Required (m ³)
10	76.8	1.93	0.32	1.61	0.97
15	61.8	1.55	0.32	1.23	1.11
20	52.0	1.30	0.32	0.99	1.19
25	45.2	1.13	0.32	0.82	1.23
30	40.0	1.00	0.32	0.69	1.24
35	36.1	0.90	0.32	0.59	1.24
40	32.9	0.82	0.32	0.51	1.22
45	30.2	0.76	0.32	0.44	1.20
50	28.0	0.70	0.32	0.39	1.16
55	26.2	0.66	0.32	0.34	1.12

Maximum Storage Required 2-Year (m³) = 1.24

5-Year Storm Event

Tc (min)	I (mm/hr)	Runoff (L/s)	Allowable	Runoff to	Storage
			Outflow (L/s)	be Stored (L/s)	Required (m ³)
10	104.2	2.61	0.32	2.30	1.38
15	83.6	2.10	0.32	1.78	1.60
20	70.3	1.76	0.32	1.45	1.74
25	60.9	1.53	0.32	1.21	1.82
30	53.9	1.35	0.32	1.04	1.87
35	48.5	1.22	0.32	0.90	1.89
40	44.18	1.11	0.32	0.79	1.90
45	40.63	1.02	0.32	0.70	1.90
50	37.65	0.94	0.32	0.63	1.89
55	35.12	0.88	0.32	0.57	1.87

Maximum Storage Required 5-Year (m³) = 1.90

100-Year Storm Event

Tc (min)	I (mm/hr)	Runoff (L/s)	Allowable	Runoff to	Storage
			Outflow (L/s)	be Stored (L/s)	Required (m ³)
45	69.1	1.93	0.32	1.62	4.36
50	64.0	1.79	0.32	1.47	4.42
55	59.6	1.67	0.32	1.35	4.46
60	55.9	1.56	0.32	1.25	4.49
65	52.6	1.47	0.32	1.16	4.51
70	49.8	1.39	0.32	1.08	4.52
75	47.3	1.32	0.32	1.01	4.53
80	45.0	1.26	0.32	0.94	4.53
85	43.0	1.20	0.32	0.89	4.52
90	41.1	1.15	0.32	0.83	4.51

Maximum Storage Required 100-Year (m³) = 4.53

McINTOSH PERRY

Storage Occupied In Area B3B

2-Year Storm Event

Roof Storage			
Location	Area	Depth	Volume (m ³)*
B3B	69.26	0.060	1.43
		Total	1.43

2-Year Storm Event

Storage Available (m ³) =	1.43
Storage Required (m ³) =	1.24

5-Year Storm Event

Roof Storage			
Location	Area	Depth	Volume (m ³)*
B3B	69.28	0.070	2.12
		Total	2.12

5-Year Storm Event

Storage Available (m ³) =	2.12
Storage Required (m ³) =	1.90

100-Year Storm Event

Roof Storage			
Location	Area	Depth	Volume (m ³)*
B3B	69.35	0.105	4.55
		Total	4.55

100-Year Storm Event

Storage Available (m ³) =	4.55
Storage Required (m ³) =	4.53

* Available Storage calculated in AutoCAD with assumed 1% roof slope. See storage summary below

Ponding Depth (m)	Area (m ²)	Incremental Volume (m ³)	Cumulative Volume (m ³)
0.01	2.06	N/A	0.00
0.02	7.90	0.05	0.05
0.03	17.83	0.13	0.18
0.04	31.71	0.25	0.43
0.05	49.54	0.41	0.83
0.06	69.26	0.59	1.43
0.07	69.28	0.69	2.12
0.08	69.30	0.69	2.81
0.09	69.32	0.69	3.51
0.1	69.34	0.69	4.20
0.11	69.36	0.69	4.89
0.12	69.39	0.69	5.59
0.13	69.41	0.69	6.28
0.14	69.43	0.69	6.97
0.15	69.46	0.69	7.67

McINTOSH PERRY

Storage Requirements for Area B3B

Roof Drains Summary			
Type of Control Device	Watts Drainage - Accutrol Weir		
Roof Drain Position	Closed		
Number of Roof Drains	1		
	2-Year	5-Year	100-Year
Rooftop Storage Available(m ³)	1.43	2.12	4.55
Rooftop Storage Required(m ³)	1.24	1.90	4.53
Storage Depth (m)	0.060	0.070	0.105
Flow (Per Roof Drain) (L/s)	0.32	0.32	0.32
Total Flow (L/s)	0.32	0.32	0.32

Flow Rate Vs. Build-Up (Individual Drain)	
Depth (mm)	Flow (L/s)
0	0.00
5	0.00
10	0.06
15	0.13
20	0.19
25	0.25
30	0.32
35	0.32
40	0.32
45	0.32
50	0.32
55	0.32
60	0.32
65	0.32
70	0.32
75	0.32
80	0.32
85	0.32
90	0.32
95	0.32
100	0.32
105	0.32
110	0.32
115	0.32
120	0.32
125	0.32
130	0.32
135	0.32
140	0.32
145	0.32
150	0.32

Roof Drain Flow			
	Flow (l/s)	Storage Depth (mm)	Drains Flow (l/s)
	0.13	15	0.13
	0.19	20	0.19
	0.25	25	0.25
	0.32	30	0.32
	0.32	35	0.32
	0.32	40	0.32
	0.32	45	0.32
	0.32	50	0.32
	0.32	55	0.32
2-Year	0.32	60	0.32
	0.32	65	0.32
5-Year	0.32	70	0.32
	0.32	75	0.32
	0.32	80	0.32
	0.32	85	0.32
	0.32	90	0.32
	0.32	95	0.32
100-Year	0.32	100	0.32
	0.32	105	0.32
	0.32	110	0.32
	0.32	115	0.32
	0.32	120	0.32
	0.32	125	0.32
	0.32	130	0.32
	0.32	135	0.32
	0.32	140	0.32
	0.32	145	0.32
	0.32	150	0.32

Note: The flow leaving through a restricted roof drain is based on flow vs. head information

McINTOSH PERRY

CP-20-0079 - 1940 Carling Ave - Runoff Calculations

27 of 42

Storage Requirements for Area B3C

2-Year Storm Event

Tc (min)	I (mm/hr)	Runoff (L/s)	Allowable	Runoff to	Storage
			Outflow (L/s)	be Stored (L/s)	Required (m ³)
10	76.8	1.75	0.32	1.43	0.86
15	61.8	1.40	0.32	1.09	0.98
20	52.0	1.18	0.32	0.87	1.04
25	45.2	1.03	0.32	0.71	1.07
30	40.0	0.91	0.32	0.60	1.07
35	36.1	0.82	0.32	0.50	1.06
40	32.9	0.75	0.32	0.43	1.04
45	30.2	0.69	0.32	0.37	1.00
50	28.0	0.64	0.32	0.32	0.97
55	26.2	0.60	0.32	0.28	0.92

Maximum Storage Required 2-Year (m³) = 1.07

5-Year Storm Event

Tc (min)	I (mm/hr)	Runoff (L/s)	Allowable	Runoff to	Storage
			Outflow (L/s)	be Stored (L/s)	Required (m ³)
10	104.2	2.37	0.32	2.05	1.23
15	83.6	1.90	0.32	1.58	1.43
20	70.3	1.60	0.32	1.28	1.54
25	60.9	1.38	0.32	1.07	1.60
30	53.9	1.23	0.32	0.91	1.64
35	48.5	1.10	0.32	0.79	1.65
40	44.18	1.00	0.32	0.69	1.65
45	40.63	0.92	0.32	0.61	1.64
50	37.65	0.86	0.32	0.54	1.62
55	35.12	0.80	0.32	0.48	1.59

Maximum Storage Required 5-Year (m³) = 1.65

100-Year Storm Event

Tc (min)	I (mm/hr)	Runoff (L/s)	Allowable	Runoff to	Storage
			Outflow (L/s)	be Stored (L/s)	Required (m ³)
45	69.1	1.76	0.32	1.44	3.89
50	64.0	1.63	0.32	1.31	3.94
55	59.6	1.52	0.32	1.20	3.97
60	55.9	1.42	0.32	1.11	3.98
65	52.6	1.34	0.32	1.02	3.99
70	49.8	1.27	0.32	0.95	4.00
75	47.3	1.20	0.32	0.89	3.99
80	45.0	1.14	0.32	0.83	3.98
85	43.0	1.09	0.32	0.78	3.97
90	41.1	1.05	0.32	0.73	3.95

Maximum Storage Required 100-Year (m³) = 4.00

McINTOSH PERRY

Storage Occupied In Area B3C

2-Year Storm Event

Roof Storage			
Location	Area	Depth	Volume (m ³)*
B3C	56.33	0.055	1.12
		Total	1.12

2-Year Storm Event

Storage Available (m ³) =	1.12
Storage Required (m ³) =	1.07

5-Year Storm Event

Roof Storage			
Location	Area	Depth	Volume (m ³)*
B3C	62.79	0.065	1.72
		Total	1.72

5-Year Storm Event

Storage Available (m ³) =	1.72
Storage Required (m ³) =	1.65

100-Year Storm Event

Roof Storage			
Location	Area	Depth	Volume (m ³)*
B3C	62.87	0.105	4.23
		Total	4.23

100-Year Storm Event

Storage Available (m ³) =	4.23
Storage Required (m ³) =	4.00

* Available Storage calculated in AutoCAD with assumed 1% roof slope. See storage summary below

Ponding Depth (m)	Area (m ²)	Incremental Volume (m ³)	Cumulative Volume (m ³)
0.01	2.14	N/A	0.00
0.02	7.95	0.05	0.05
0.03	17.95	0.13	0.18
0.04	31.92	0.25	0.43
0.05	49.87	0.41	0.84
0.06	62.78	0.56	1.40
0.07	62.80	0.63	2.03
0.08	62.82	0.63	2.66
0.09	62.84	0.63	3.29
0.1	62.86	0.63	3.91
0.11	62.88	0.63	4.54
0.12	62.90	0.63	5.17
0.13	62.92	0.63	5.80
0.14	62.95	0.63	6.43
0.15	62.97	0.63	7.06

McINTOSH PERRY

Storage Requirements for Area B3C

Roof Drains Summary			
Type of Control Device	Watts Drainage - Accutrol Weir		
Roof Drain Position	Closed		
Number of Roof Drains	1		
	2-Year	5-Year	100-Year
Rooftop Storage Available(m ³)	1.12	1.72	4.23
Rooftop Storage Required(m ³)	1.07	1.65	4.00
Storage Depth (m)	0.055	0.065	0.105
Flow (Per Roof Drain) (L/s)	0.32	0.32	0.32
Total Flow (L/s)	0.32	0.32	0.32

Flow Rate Vs. Build-Up (Individual Drain)	
Depth (mm)	Flow (L/s)
0	0.00
5	0.00
10	0.06
15	0.13
20	0.19
25	0.25
30	0.32
35	0.32
40	0.32
45	0.32
50	0.32
55	0.32
60	0.32
65	0.32
70	0.32
75	0.32
80	0.32
85	0.32
90	0.32
95	0.32
100	0.32
105	0.32
110	0.32
115	0.32
120	0.32
125	0.32
130	0.32
135	0.32
140	0.32
145	0.32
150	0.32

Roof Drain Flow			
	Flow (l/s)	Storage Depth (mm)	Drains Flow (l/s)
	0.13	15	0.13
	0.19	20	0.19
	0.25	25	0.25
	0.32	30	0.32
	0.32	35	0.32
	0.32	40	0.32
	0.32	45	0.32
	0.32	50	0.32
2-Year	0.32	55	0.32
	0.32	60	0.32
5-Year	0.32	65	0.32
	0.32	70	0.32
	0.32	75	0.32
	0.32	80	0.32
	0.32	85	0.32
	0.32	90	0.32
	0.32	95	0.32
100-Year	0.32	100	0.32
	0.32	105	0.32
	0.32	110	0.32
	0.32	115	0.32
	0.32	120	0.32
	0.32	125	0.32
	0.32	130	0.32
	0.32	135	0.32
	0.32	140	0.32
	0.32	145	0.32
	0.32	150	0.32

Note: The flow leaving through a restricted roof drain is based on flow vs. head information

McINTOSH PERRY

CP-20-0079 - 1940 Carling Ave - Runoff Calculations

30 of 42

Storage Requirements for Area B4A

2-Year Storm Event

Tc (min)	I (mm/hr)	Runoff (L/s)	Allowable	Runoff to	Storage
			Outflow (L/s)	be Stored (L/s)	Required (m ³)
10	76.8	0.46	0.32	0.15	0.09
15	61.8	0.37	0.32	0.06	0.05
20	52.0	0.31	0.32	0.00	0.00
25	45.2	0.27	0.32	-0.04	-0.07
30	40.0	0.24	0.32	-0.07	-0.13
35	36.1	0.22	0.32	-0.10	-0.21
40	32.9	0.20	0.32	-0.12	-0.28
45	30.2	0.18	0.32	-0.13	-0.36
50	28.0	0.17	0.32	-0.15	-0.44
55	26.2	0.16	0.32	-0.16	-0.52

Maximum Storage Required 2-Year (m³) = 0.09

5-Year Storm Event

Tc (min)	I (mm/hr)	Runoff (L/s)	Allowable	Runoff to	Storage
			Outflow (L/s)	be Stored (L/s)	Required (m ³)
10	104.2	0.63	0.32	0.31	0.19
15	83.6	0.50	0.32	0.19	0.17
20	70.3	0.42	0.32	0.11	0.13
25	60.9	0.37	0.32	0.05	0.08
30	53.9	0.32	0.32	0.01	0.02
35	48.5	0.29	0.32	-0.02	-0.05
40	44.18	0.27	0.32	-0.05	-0.12
45	40.63	0.24	0.32	-0.07	-0.19
50	37.65	0.23	0.32	-0.09	-0.27
55	35.12	0.21	0.32	-0.10	-0.34

Maximum Storage Required 5-Year (m³) = 0.19

100-Year Storm Event

Tc (min)	I (mm/hr)	Runoff (L/s)	Allowable	Runoff to	Storage
			Outflow (L/s)	be Stored (L/s)	Required (m ³)
10	178.6	1.19	0.32	0.88	0.53
15	142.9	0.95	0.32	0.64	0.57
20	120.0	0.80	0.32	0.48	0.58
25	103.8	0.69	0.32	0.38	0.57
30	91.9	0.61	0.32	0.30	0.54
35	82.6	0.55	0.32	0.24	0.49
40	75.1	0.50	0.32	0.19	0.45
45	69.1	0.46	0.32	0.15	0.39
50	64.0	0.43	0.32	0.11	0.33
55	59.6	0.40	0.32	0.08	0.27

Maximum Storage Required 100-Year (m³) = 0.58

McINTOSH PERRY

Storage Occupied In Area B4A

2-Year Storm Event

Roof Storage			
Location	Area	Depth	Volume (m ³)*
B4A	16.80	0.030	0.17
		Total	0.17

2-Year Storm Event

Storage Available (m ³) =	0.17
Storage Required (m ³) =	0.09

5-Year Storm Event

Roof Storage			
Location	Area	Depth	Volume (m ³)*
B4A	18.16	0.035	0.26
		Total	0.26

5-Year Storm Event

Storage Available (m ³) =	0.26
Storage Required (m ³) =	0.19

100-Year Storm Event

Roof Storage			
Location	Area	Depth	Volume (m ³)*
B4A	19.54	0.055	0.65
		Total	0.65

100-Year Storm Event

Storage Available (m ³) =	0.65
Storage Required (m ³) =	0.58

* Available Storage calculated in AutoCAD with assumed 1% roof slope. See storage summary below

Ponding Depth (m)	Area (m ²)	Incremental Volume (m ³)	Cumulative Volume (m ³)
0.01	1.88	N/A	0.00
0.02	7.52	0.05	0.05
0.03	16.80	0.12	0.17
0.04	19.52	0.18	0.35
0.05	19.53	0.20	0.55
0.06	19.54	0.20	0.74
0.07	19.55	0.20	0.94
0.08	19.57	0.20	1.13
0.09	19.58	0.20	1.33
0.1	19.59	0.20	1.52
0.11	19.61	0.20	1.72
0.12	19.62	0.20	1.92
0.13	19.63	0.20	2.11
0.14	19.64	0.20	2.31
0.15	19.66	0.20	2.50

McINTOSH PERRY

Storage Requirements for Area B4A

Roof Drains Summary			
Type of Control Device	Watts Drainage - Accutrol Weir		
Roof Drain Position	Closed		
Number of Roof Drains	1		
	2-Year	5-Year	100-Year
Rooftop Storage Available(m ³)	0.17	0.26	0.65
Rooftop Storage Required(m ³)	0.09	0.19	0.58
Storage Depth (m)	0.030	0.035	0.055
Flow (Per Roof Drain) (L/s)	0.32	0.32	0.32
Total Flow (L/s)	0.32	0.32	0.32

Flow Rate Vs. Build-Up (Individual Drain)	
Depth (mm)	Flow (L/s)
0	0.00
5	0.00
10	0.06
15	0.13
20	0.19
25	0.25
30	0.32
35	0.32
40	0.32
45	0.32
50	0.32
55	0.32
60	0.32
65	0.32
70	0.32
75	0.32
80	0.32
85	0.32
90	0.32
95	0.32
100	0.32
105	0.32
110	0.32
115	0.32
120	0.32
125	0.32
130	0.32
135	0.32
140	0.32
145	0.32
150	0.32

Roof Drain Flow			
	Flow (l/s)	Storage Depth (mm)	Drains Flow (l/s)
	0.13	15	0.13
	0.19	20	0.19
	0.25	25	0.25
2-Year	0.32	30	0.32
5-Year	0.32	35	0.32
	0.32	40	0.32
	0.32	45	0.32
100-Year	0.32	50	0.32
	0.32	55	0.32
	0.32	60	0.32
	0.32	65	0.32
	0.32	70	0.32
	0.32	75	0.32
	0.32	80	0.32
	0.32	85	0.32
	0.32	90	0.32
	0.32	95	0.32
	0.32	100	0.32
	0.32	105	0.32
	0.32	110	0.32
	0.32	115	0.32
	0.32	120	0.32
	0.32	125	0.32
	0.32	130	0.32
	0.32	135	0.32
	0.32	140	0.32
	0.32	145	0.32
	0.32	150	0.32

Note: The flow leaving through a restricted roof drain is based on flow vs. head information

McINTOSH PERRY

CP-20-0079 - 1940 Carling Ave - Runoff Calculations

33 of 42

Storage Requirements for Area B4B

2-Year Storm Event

Tc (min)	I (mm/hr)	Runoff (L/s)	Allowable	Runoff to	Storage
			Outflow (L/s)	be Stored (L/s)	Required (m ³)
10	76.8	0.48	0.32	0.16	0.10
15	61.8	0.39	0.32	0.07	0.06
20	52.0	0.33	0.32	0.01	0.01
25	45.2	0.28	0.32	-0.03	-0.05
30	40.0	0.25	0.32	-0.07	-0.12
35	36.1	0.23	0.32	-0.09	-0.19
40	32.9	0.21	0.32	-0.11	-0.26
45	30.2	0.19	0.32	-0.13	-0.34
50	28.0	0.18	0.32	-0.14	-0.42
55	26.2	0.16	0.32	-0.15	-0.50

Maximum Storage Required 2-Year (m³) = 0.10

5-Year Storm Event

Tc (min)	I (mm/hr)	Runoff (L/s)	Allowable	Runoff to	Storage
			Outflow (L/s)	be Stored (L/s)	Required (m ³)
10	104.2	0.65	0.32	0.34	0.20
15	83.6	0.52	0.32	0.21	0.19
20	70.3	0.44	0.32	0.12	0.15
25	60.9	0.38	0.32	0.07	0.10
30	53.9	0.34	0.32	0.02	0.04
35	48.5	0.30	0.32	-0.01	-0.03
40	44.18	0.28	0.32	-0.04	-0.09
45	40.63	0.25	0.32	-0.06	-0.17
50	37.65	0.24	0.32	-0.08	-0.24
55	35.12	0.22	0.32	-0.10	-0.32

Maximum Storage Required 5-Year (m³) = 0.20

100-Year Storm Event

Tc (min)	I (mm/hr)	Runoff (L/s)	Allowable	Runoff to	Storage
			Outflow (L/s)	be Stored (L/s)	Required (m ³)
10	178.6	1.24	0.32	0.93	0.56
15	142.9	0.99	0.32	0.68	0.61
20	120.0	0.83	0.32	0.52	0.62
25	103.8	0.72	0.32	0.41	0.61
30	91.9	0.64	0.32	0.32	0.58
35	82.6	0.57	0.32	0.26	0.54
40	75.1	0.52	0.32	0.21	0.50
45	69.1	0.48	0.32	0.16	0.44
50	64.0	0.44	0.32	0.13	0.39
55	59.6	0.41	0.32	0.10	0.33

Maximum Storage Required 100-Year (m³) = 0.62

McINTOSH PERRY

CP-20-0079 - 1940 Carling Ave - Runoff Calculations

34 of 42

Storage Occupied In Area B4B

2-Year Storm Event

Roof Storage			
Location	Area	Depth	Volume (m ³)*
B4B	17.49	0.030	0.18
Total			0.18

2-Year Storm Event

Storage Available (m ³) =	0.18
Storage Required (m ³) =	0.10

5-Year Storm Event

Roof Storage			
Location	Area	Depth	Volume (m ³)*
B4B	20.24	0.035	0.28
Total			0.28

5-Year Storm Event

Storage Available (m ³) =	0.28
Storage Required (m ³) =	0.20

100-Year Storm Event

Roof Storage			
Location	Area	Depth	Volume (m ³)*
B4B	23.00	0.055	0.73
Total			0.73

100-Year Storm Event

Storage Available (m ³) =	0.73
Storage Required (m ³) =	0.62

* Available Storage calculated in AutoCAD with assumed 1% roof slope. See storage summary below

Ponding Depth (m)	Area (m ²)	Incremental Volume (m ³)	Cumulative Volume (m ³)
0.01	2.11	N/A	0.00
0.02	8.44	0.05	0.05
0.03	17.49	0.13	0.18
0.04	22.98	0.20	0.38
0.05	22.99	0.23	0.61
0.06	23.00	0.23	0.84
0.07	23.01	0.23	1.07
0.08	23.02	0.23	1.30
0.09	23.04	0.23	1.53
0.1	23.05	0.23	1.77
0.11	23.07	0.23	2.00
0.12	23.09	0.23	2.23
0.13	23.10	0.23	2.46
0.14	23.11	0.23	2.69
0.15	23.13	0.23	2.92

McINTOSH PERRY

Storage Requirements for Area B4B

Roof Drains Summary			
Type of Control Device	Watts Drainage - Accutrol Weir		
Roof Drain Position	Closed		
Number of Roof Drains	1		
	2-Year	5-Year	100-Year
Rooftop Storage Available(m ³)	0.18	0.28	0.73
Rooftop Storage Required(m ³)	0.10	0.20	0.62
Storage Depth (m)	0.030	0.035	0.055
Flow (Per Roof Drain) (L/s)	0.32	0.32	0.32
Total Flow (L/s)	0.32	0.32	0.32

Flow Rate Vs. Build-Up (Individual Drain)	
Depth (mm)	Flow (L/s)
0	0.00
5	0.00
10	0.06
15	0.13
20	0.19
25	0.25
30	0.32
35	0.32
40	0.32
45	0.32
50	0.32
55	0.32
60	0.32
65	0.32
70	0.32
75	0.32
80	0.32
85	0.32
90	0.32
95	0.32
100	0.32
105	0.32
110	0.32
115	0.32
120	0.32
125	0.32
130	0.32
135	0.32
140	0.32
145	0.32
150	0.32

Roof Drain Flow			
	Flow (l/s)	Storage Depth (mm)	Drains Flow (l/s)
	0.13	15	0.13
	0.19	20	0.19
	0.25	25	0.25
2-Year	0.32	30	0.32
5-Year	0.32	35	0.32
	0.32	40	0.32
	0.32	45	0.32
100-Year	0.32	50	0.32
	0.32	55	0.32
	0.32	60	0.32
	0.32	65	0.32
	0.32	70	0.32
	0.32	75	0.32
	0.32	80	0.32
	0.32	85	0.32
	0.32	90	0.32
	0.32	95	0.32
	0.32	100	0.32
	0.32	105	0.32
	0.32	110	0.32
	0.32	115	0.32
	0.32	120	0.32
	0.32	125	0.32
	0.32	130	0.32
	0.32	135	0.32
	0.32	140	0.32
	0.32	145	0.32
	0.32	150	0.32

Note: The flow leaving through a restricted roof drain is based on flow vs. head information

McINTOSH PERRY

CP-20-0079 - 1940 Carling Ave - Runoff Calculations

36 of 42

Storage Requirements for Area B5A

2-Year Storm Event

Tc (min)	I (mm/hr)	Runoff (L/s)	Allowable	Runoff to	Storage
			Outflow (L/s)	be Stored (L/s)	Required (m ³)
10	76.8	0.36	0.25	0.11	0.07
15	61.8	0.29	0.25	0.04	0.03
20	52.0	0.25	0.25	-0.01	-0.01
25	45.2	0.21	0.25	-0.04	-0.06
30	40.0	0.19	0.25	-0.06	-0.11
35	36.1	0.17	0.25	-0.08	-0.17
40	32.9	0.15	0.25	-0.10	-0.23
45	30.2	0.14	0.25	-0.11	-0.30
50	28.0	0.13	0.25	-0.12	-0.36
55	26.2	0.12	0.25	-0.13	-0.43

Maximum Storage Required 2-Year (m³) = 0.07

5-Year Storm Event

Tc (min)	I (mm/hr)	Runoff (L/s)	Allowable	Runoff to	Storage
			Outflow (L/s)	be Stored (L/s)	Required (m ³)
10	104.2	0.49	0.32	0.18	0.11
15	83.6	0.39	0.32	0.08	0.07
20	70.3	0.33	0.32	0.02	0.02
25	60.9	0.29	0.32	-0.03	-0.04
30	53.9	0.25	0.32	-0.06	-0.11
35	48.5	0.23	0.32	-0.09	-0.18
40	44.18	0.21	0.32	-0.11	-0.26
45	40.63	0.19	0.32	-0.12	-0.33
50	37.65	0.18	0.32	-0.14	-0.41
55	35.12	0.17	0.32	-0.15	-0.49

Maximum Storage Required 5-Year (m³) = 0.11

100-Year Storm Event

Tc (min)	I (mm/hr)	Runoff (L/s)	Allowable	Runoff to	Storage
			Outflow (L/s)	be Stored (L/s)	Required (m ³)
10	178.6	0.94	0.32	0.62	0.37
15	142.9	0.75	0.32	0.43	0.39
20	120.0	0.63	0.32	0.31	0.38
25	103.8	0.54	0.32	0.23	0.34
30	91.9	0.48	0.32	0.17	0.30
35	82.6	0.43	0.32	0.12	0.25
40	75.1	0.39	0.32	0.08	0.19
45	69.1	0.36	0.32	0.05	0.12
50	64.0	0.33	0.32	0.02	0.06
55	59.6	0.31	0.32	0.00	-0.01

Maximum Storage Required 100-Year (m³) = 0.39

McINTOSH PERRY

Storage Occupied In Area B5A

2-Year Storm Event

Roof Storage			
Location	Area	Depth	Volume (m ³)*
B5A	12.91	0.025	0.14
		Total	0.14

2-Year Storm Event

Storage Available (m ³) =	0.14
Storage Required (m ³) =	0.07

5-Year Storm Event

Roof Storage			
Location	Area	Depth	Volume (m ³)*
B5A	16.04	0.030	0.20
		Total	0.20

5-Year Storm Event

Storage Available (m ³) =	0.20
Storage Required (m ³) =	0.11

100-Year Storm Event

Roof Storage			
Location	Area	Depth	Volume (m ³)*
B5A	17.83	0.045	0.46
		Total	0.46

100-Year Storm Event

Storage Available (m ³) =	0.46
Storage Required (m ³) =	0.39

* Available Storage calculated in AutoCAD with assumed 1% roof slope. See storage summary below

Ponding Depth (m)	Area (m ²)	Incremental Volume (m ³)	Cumulative Volume (m ³)
0.01	2.66	0.01	0.01
0.02	9.77	0.06	0.08
0.03	16.04	0.13	0.20
0.04	17.82	0.17	0.37
0.05	17.83	0.18	0.55
0.06	17.84	0.18	0.73
0.07	17.85	0.18	0.91
0.08	17.86	0.18	1.09
0.09	17.88	0.18	1.27
0.1	17.89	0.18	1.44
0.11	17.90	0.18	1.62
0.12	17.91	0.18	1.80
0.13	17.93	0.18	1.98
0.14	17.94	0.18	2.16
0.15	17.95	0.18	2.34

McINTOSH PERRY

Storage Requirements for Area B5A

Roof Drains Summary			
Type of Control Device	Watts Drainage - Accutrol Weir		
Roof Drain Position	Closed		
Number of Roof Drains	1		
	2-Year	5-Year	100-Year
Rooftop Storage Available(m ³)	0.14	0.20	0.46
Rooftop Storage Required(m ³)	0.07	0.11	0.39
Storage Depth (m)	0.025	0.030	0.045
Flow (Per Roof Drain) (L/s)	0.25	0.32	0.32
Total Flow (L/s)	0.25	0.32	0.32

Flow Rate Vs. Build-Up (Individual Drain)	
Depth (mm)	Flow (L/s)
0	0.00
5	0.00
10	0.06
15	0.13
20	0.19
25	0.25
30	0.32
35	0.32
40	0.32
45	0.32
50	0.32
55	0.32
60	0.32
65	0.32
70	0.32
75	0.32
80	0.32
85	0.32
90	0.32
95	0.32
100	0.32
105	0.32
110	0.32
115	0.32
120	0.32
125	0.32
130	0.32
135	0.32
140	0.32
145	0.32
150	0.32

Roof Drain Flow			
	Flow (l/s)	Storage Depth (mm)	Drains Flow (l/s)
	0.13	15	0.13
	0.19	20	0.19
2-Year	0.25	25	0.25
5-Year	0.32	30	0.32
	0.32	35	0.32
	0.32	40	0.32
100-Year	0.32	45	0.32
	0.32	50	0.32
	0.32	55	0.32
	0.32	60	0.32
	0.32	65	0.32
	0.32	70	0.32
	0.32	75	0.32
	0.32	80	0.32
	0.32	85	0.32
	0.32	90	0.32
	0.32	95	0.32
	0.32	100	0.32
	0.32	105	0.32
	0.32	110	0.32
	0.32	115	0.32
	0.32	120	0.32
	0.32	125	0.32
	0.32	130	0.32
	0.32	135	0.32
	0.32	140	0.32
	0.32	145	0.32
	0.32	150	0.32

Note: The flow leaving through a restricted roof drain is based on flow vs. head information

McINTOSH PERRY

CP-20-0079 - 1940 Carling Ave - Runoff Calculations

39 of 42

Storage Requirements for Area B5B

2-Year Storm Event

Tc (min)	I (mm/hr)	Runoff (L/s)	Allowable	Runoff to	Storage
			Outflow (L/s)	be Stored (L/s)	Required (m ³)
10	76.8	0.36	0.25	0.10	0.06
15	61.8	0.29	0.25	0.03	0.03
20	52.0	0.24	0.25	-0.01	-0.01
25	45.2	0.21	0.25	-0.04	-0.06
30	40.0	0.19	0.25	-0.07	-0.12
35	36.1	0.17	0.25	-0.09	-0.18
40	32.9	0.15	0.25	-0.10	-0.24
45	30.2	0.14	0.25	-0.11	-0.30
50	28.0	0.13	0.25	-0.12	-0.37
55	26.2	0.12	0.25	-0.13	-0.43

Maximum Storage Required 2-Year (m³) = 0.06

5-Year Storm Event

Tc (min)	I (mm/hr)	Runoff (L/s)	Allowable	Runoff to	Storage
			Outflow (L/s)	be Stored (L/s)	Required (m ³)
10	104.2	0.48	0.32	0.17	0.10
15	83.6	0.39	0.32	0.07	0.07
20	70.3	0.33	0.32	0.01	0.01
25	60.9	0.28	0.32	-0.03	-0.05
30	53.9	0.25	0.32	-0.07	-0.12
35	48.5	0.23	0.32	-0.09	-0.19
40	44.18	0.21	0.32	-0.11	-0.26
45	40.63	0.19	0.32	-0.13	-0.34
50	37.65	0.17	0.32	-0.14	-0.42
55	35.12	0.16	0.32	-0.15	-0.50

Maximum Storage Required 5-Year (m³) = 0.10

100-Year Storm Event

Tc (min)	I (mm/hr)	Runoff (L/s)	Allowable	Runoff to	Storage
			Outflow (L/s)	be Stored (L/s)	Required (m ³)
10	178.6	0.92	0.32	0.61	0.36
15	142.9	0.74	0.32	0.42	0.38
20	120.0	0.62	0.32	0.30	0.36
25	103.8	0.54	0.32	0.22	0.33
30	91.9	0.47	0.32	0.16	0.28
35	82.6	0.43	0.32	0.11	0.23
40	75.1	0.39	0.32	0.07	0.17
45	69.1	0.36	0.32	0.04	0.11
50	64.0	0.33	0.32	0.01	0.04
55	59.6	0.31	0.32	-0.01	-0.03

Maximum Storage Required 100-Year (m³) = 0.38

McINTOSH PERRY

Storage Occupied In Area B5B

2-Year Storm Event

Roof Storage			
Location	Area	Depth	Volume (m ³)*
B5B	12.12	0.025	0.11
		Total	0.11

2-Year Storm Event

Storage Available (m ³) =	0.11
Storage Required (m ³) =	0.06

5-Year Storm Event

Roof Storage			
Location	Area	Depth	Volume (m ³)*
B5B	15.92	0.030	0.17
		Total	0.17

5-Year Storm Event

Storage Available (m ³) =	0.17
Storage Required (m ³) =	0.10

100-Year Storm Event

Roof Storage			
Location	Area	Depth	Volume (m ³)*
B5B	17.69	0.045	0.43
		Total	0.43

100-Year Storm Event

Storage Available (m ³) =	0.43
Storage Required (m ³) =	0.38

* Available Storage calculated in AutoCAD with assumed 1% roof slope. See storage summary below

Ponding Depth (m)	Area (m ²)	Incremental Volume (m ³)	Cumulative Volume (m ³)
0.01	2.24	N/A	0.00
0.02	8.32	0.05	0.05
0.03	15.92	0.12	0.17
0.04	17.68	0.17	0.34
0.05	17.69	0.18	0.52
0.06	17.69	0.18	0.70
0.07	17.70	0.18	0.87
0.08	17.71	0.18	1.05
0.09	17.72	0.18	1.23
0.1	17.73	0.18	1.40
0.11	17.74	0.18	1.58
0.12	17.76	0.18	1.76
0.13	17.77	0.18	1.94
0.14	17.78	0.18	2.11
0.15	17.79	0.18	2.29

McINTOSH PERRY

Storage Requirements for Area B5B

Roof Drains Summary			
Type of Control Device	Watts Drainage - Accutrol Weir		
Roof Drain Position	Closed		
Number of Roof Drains	1		
	2-Year	5-Year	100-Year
Rooftop Storage Available(m ³)	0.11	0.17	0.43
Rooftop Storage Required(m ³)	0.06	0.10	0.38
Storage Depth (m)	0.025	0.030	0.045
Flow (Per Roof Drain) (L/s)	0.25	0.32	0.32
Total Flow (L/s)	0.25	0.32	0.32

Flow Rate Vs. Build-Up (Individual Drain)	
Depth (mm)	Flow (L/s)
0	0.00
5	0.00
10	0.06
15	0.13
20	0.19
25	0.25
30	0.32
35	0.32
40	0.32
45	0.32
50	0.32
55	0.32
60	0.32
65	0.32
70	0.32
75	0.32
80	0.32
85	0.32
90	0.32
95	0.32
100	0.32
105	0.32
110	0.32
115	0.32
120	0.32
125	0.32
130	0.32
135	0.32
140	0.32
145	0.32
150	0.32

Roof Drain Flow			
	Flow (l/s)	Storage Depth (mm)	Drains Flow (l/s)
	0.13	15	0.13
	0.19	20	0.19
2-Year	0.25	25	0.25
5-Year	0.32	30	0.32
	0.32	35	0.32
	0.32	40	0.32
100-Year	0.32	45	0.32
	0.32	50	0.32
	0.32	55	0.32
	0.32	60	0.32
	0.32	65	0.32
	0.32	70	0.32
	0.32	75	0.32
	0.32	80	0.32
	0.32	85	0.32
	0.32	90	0.32
	0.32	95	0.32
	0.32	100	0.32
	0.32	105	0.32
	0.32	110	0.32
	0.32	115	0.32
	0.32	120	0.32
	0.32	125	0.32
	0.32	130	0.32
	0.32	135	0.32
	0.32	140	0.32
	0.32	145	0.32
	0.32	150	0.32

Note: The flow leaving through a restricted roof drain is based on flow vs. head information

McINTOSH PERRY

CP-20-0079 - 1940 Carling Ave - Runoff Calculations

42 of 42

Time of Concentration Pre-Development

Drainage Area ID	Sheet Flow Distance (m)	Slope of Land (%)	Tc (min) (5-Year)	Tc (min) (100-Year)
A1	55	1.22	7	5

Therefore, a Tc of 10 can be used

$$T_c = (3.26(1.1-c)L^{0.5}/S^{0.33})$$

c= Balanced Runoff Coefficient

L= Length of drainage area

S= Average slope of watershed

STORM SEWER DESIGN SHEET



PROJECT: Residential
 LOCATION: 1940 Carling Avenue
 CLIENT: Domenic Santaguida

LOCATION				CONTRIBUTING AREA (ha)						RATIONAL DESIGN FLOW						SEWER DATA										
STREET	AREA ID	FROM MH	TO MH	C-VALUE					INDIV AC	CUMUL AC	INLET (min)	TIME IN PIPE	TOTAL (min)	i (2) (mm/hr)	2yr PEAK FLOW (L/s)	FIXED FLOW (L/s)	DESIGN FLOW (L/s)	CAPACITY (L/s)	LENGTH (m)	PIPE SIZE (mm)			SLOPE (%)	VELOCITY (m/s)	AVAIL CAP (5yr)	
				0.20	0.40	0.79	0.85	0.87												0.90	DIA	W			H	(L/s)
	B6	LCB1	LCB2		0.06					0.02	0.02	10.00	0.36	10.36	76.81	5.18	5.18	43.87	18.85	250			0.50	0.866	38.69	88.20%
		LCB2	LCB3							0.02	0.02	10.36	0.40	10.76	75.44	5.09	5.09	43.87	20.85	250			0.50	0.866	38.78	88.41%
		LCB3	TEE							0.02	0.02	10.76	0.12	10.88	73.99	4.99	4.99	43.87	6.12	250			0.50	0.866	38.88	88.63%
	B1 + B6	BLDG/ Roof	EX. MAIN	0.01					0.08	0.08	0.10	10.76	0.27	11.04	73.99	20.98	20.98	62.04	20.15	250			1.00	1.224	41.06	66.18%
Definitions: Q = 2.78QA, where: Q = Peak Flow in Litres per Second (L/s) A = Area in Hectares (ha) i = Rainfall intensity in millimeters per hour (mm/hr) [i = 998.071 / (TC+6.053)^0.814] 5 YEAR [i = 1174.184 / (TC+6.014)^0.816] 10 YEAR [i = 1735.688 / (TC+6.014)^0.820] 100 YEAR				Notes: 1. Mannings coefficient (n) = 0.013						Designed: N.V.B.						Revision			Date							
										Checked: T.D.F.						Issued for Review			2021-05-28							
										Project No.: CP-20-0079						Issued for Review			2023-01-04							
																			2023-07-06							
																			Sheet No: 1 of 1							



Adjustable Accutrol Weir

Tag: _____

Adjustable Flow Control for Roof Drains

ADJUSTABLE ACCUTROL (for Large Sump Roof Drains only)

For more flexibility in controlling flow with heads deeper than 2", Watts Drainage offers the Adjustable Accutrol. The Adjustable Accutrol Weir is designed with a single parabolic opening that can be covered to restrict flow above 2" of head to less than 5 gpm per inch, up to 6" of head. To adjust the flow rate for depths over 2" of head, set the slot in the adjustable upper cone according to the flow rate required. Refer to Table 1 below.
 Note: Flow rates are directly proportional to the amount of weir opening that is exposed.

EXAMPLE:

For example, if the adjustable upper cone is set to cover 1/2 of the weir opening, flow rates above 2" of head will be restricted to 2-1/2 gpm per inch of head.

Therefore, at 3" of head, the flow rate through the Accutrol Weir that has 1/2 the slot exposed will be:
 [5 gpm (per inch of head) x 2 inches of head] + 2-1/2 gpm (for the third inch of head) = 12-1/2 gpm.

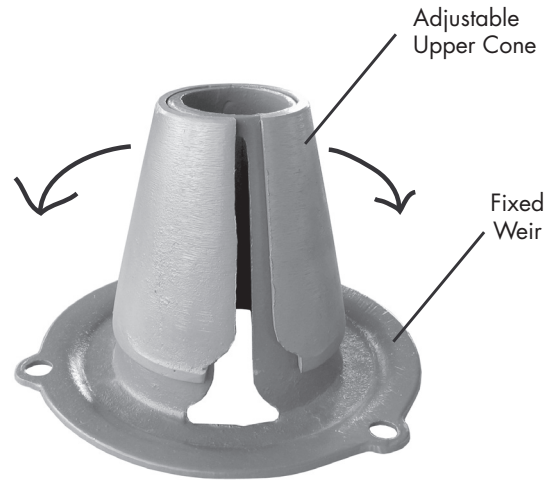
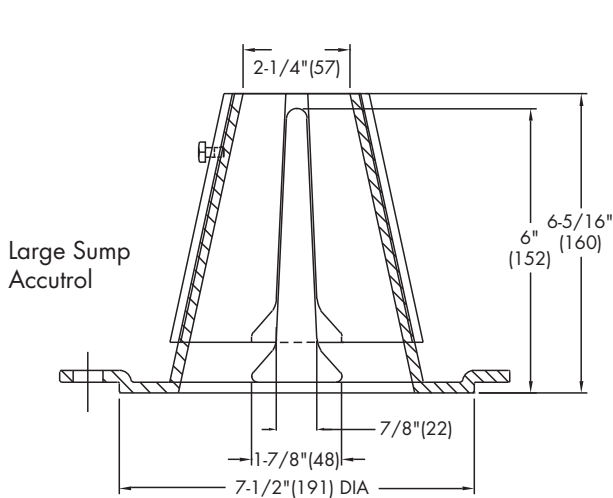

1/2 Weir Opening Exposed Shown Above

TABLE 1. Adjustable Accutrol Flow Rate Settings

Weir Opening Exposed	1"	2"	3"	4"	5"	6"
	Flow Rate (gallons per minute)					
Fully Exposed	5	10	15	20	25	30
3/4	5	10	13.75	17.5	21.25	25
1/2	5	10	12.5	15	17.5	20
1/4	5	10	11.25	12.5	13.75	15
Closed	5	5	5	5	5	5

Job Name _____
 Job Location _____
 Engineer _____

Contractor _____
 Contractor's P.O. No. _____
 Representative _____

Watts product specifications in U.S. customary units and metric are approximate and are provided for reference only. For precise measurements, please contact Watts Technical Service. Watts reserves the right to change or modify product design, construction, specifications, or materials without prior notice and without incurring any obligation to make such changes and modifications on Watts products previously or subsequently sold.

USA: Tel: (800) 338-2581 • Fax: (828) 248-3929 • Watts.com
 Canada: Tel: (905) 332-4090 • Fax: (905) 332-7068 • Watts.ca
 Latin America: Tel: (52) 81-1001-8600 • Fax: (52) 81-8000-7091 • Watts.com



A Watts Water Technologies Company

**APPENDIX H
CITY OF OTTAWA DESIGN CHECKLIST**

City of Ottawa

4. Development Servicing Study Checklist

The following section describes the checklist of the required content of servicing studies. It is expected that the proponent will address each one of the following items for the study to be deemed complete and ready for review by City of Ottawa Infrastructure Approvals staff.

The level of required detail in the Servicing Study will increase depending on the type of application. For example, for Official Plan amendments and re-zoning applications, the main issues will be to determine the capacity requirements for the proposed change in land use and confirm this against the existing capacity constraint, and to define the solutions, phasing of works and the financing of works to address the capacity constraint. For subdivisions and site plans, the above will be required with additional detailed information supporting the servicing within the development boundary.

4.1 General Content

Criteria	Location (if applicable)
<input type="checkbox"/> Executive Summary (for larger reports only).	N/A
<input type="checkbox"/> Date and revision number of the report.	On Cover
<input type="checkbox"/> Location map and plan showing municipal address, boundary, and layout of proposed development.	Appendix E
<input type="checkbox"/> Plan showing the site and location of all existing services.	Site Servicing Plan (C102)
<input type="checkbox"/> Development statistics, land use, density, adherence to zoning and official plan, and reference to applicable subwatershed and watershed plans that provide context to which individual developments must adhere.	1.1 Purpose 1.2 Site Description 6.0 Stormwater Management
<input type="checkbox"/> Summary of pre-consultation meetings with City and other approval agencies.	Appendix A
<input type="checkbox"/> Reference and confirm conformance to higher level studies and reports (Master Servicing Studies, Environmental Assessments, Community Design Plans), or in the case where it is not in conformance, the proponent must provide justification and develop a defensible design criteria.	1.1 Purpose 1.2 Site Description 6.0 Stormwater Management
<input type="checkbox"/> Statement of objectives and servicing criteria.	3.0 Pre-Consultation Summary

<input type="checkbox"/> Identification of existing and proposed infrastructure available in the immediate area.	N/A
<input type="checkbox"/> Identification of Environmentally Significant Areas, watercourses and Municipal Drains potentially impacted by the proposed development (Reference can be made to the Natural Heritage Studies, if available).	Site Grading, Drainage, Sediment & Erosion Control Plan (C101)
<input type="checkbox"/> Concept level master grading plan to confirm existing and proposed grades in the development. This is required to confirm the feasibility of proposed stormwater management and drainage, soil removal and fill constraints, and potential impacts to neighbouring properties. This is also required to confirm that the proposed grading will not impede existing major system flow paths.	Site Grading, Drainage, Sediment & Erosion Control Plan (C101)
<input type="checkbox"/> Identification of potential impacts of proposed piped services on private services (such as wells and septic fields on adjacent lands) and mitigation required to address potential impacts.	N/A
<input type="checkbox"/> Proposed phasing of the development, if applicable.	N/A
<input type="checkbox"/> Reference to geotechnical studies and recommendations concerning servicing.	Section 2.0 Background Studies
<input type="checkbox"/> All preliminary and formal site plan submissions should have the following information: <ul style="list-style-type: none"> ○ Metric scale ○ North arrow (including construction North) ○ Key plan ○ Name and contact information of applicant and property owner ○ Property limits including bearings and dimensions ○ Existing and proposed structures and parking areas ○ Easements, road widening and rights-of-way ○ Adjacent street names 	Site Grading, Drainage, Sediment & Erosion Control Plan (C101)

4.2 Development Servicing Report: Water

Criteria	Location (if applicable)
<input type="checkbox"/> Confirm consistency with Master Servicing Study, if available	N/A
<input type="checkbox"/> Availability of public infrastructure to service proposed development	N/A
<input type="checkbox"/> Identification of system constraints	N/A
<input type="checkbox"/> Identify boundary conditions	N/A
<input type="checkbox"/> Confirmation of adequate domestic supply and pressure	N/A
<input type="checkbox"/> Confirmation of adequate fire flow protection and confirmation that fire flow is calculated as per the Fire Underwriter’s Survey. Output should show available fire flow at locations throughout the development.	Appendix B
<input type="checkbox"/> Provide a check of high pressures. If pressure is found to be high, an assessment is required to confirm the application of pressure reducing valves.	N/A
<input type="checkbox"/> Definition of phasing constraints. Hydraulic modeling is required to confirm servicing for all defined phases of the project including the ultimate design	N/A
<input type="checkbox"/> Address reliability requirements such as appropriate location of shut-off valves	N/A
<input type="checkbox"/> Check on the necessity of a pressure zone boundary modification.	N/A
<input type="checkbox"/> Reference to water supply analysis to show that major infrastructure is capable of delivering sufficient water for the proposed land use. This includes data that shows that the expected demands under average day, peak hour and fire flow conditions provide water within the required pressure range	N/A

<input type="checkbox"/> Description of the proposed water distribution network, including locations of proposed connections to the existing system, provisions for necessary looping, and appurtenances (valves, pressure reducing valves, valve chambers, and fire hydrants) including special metering provisions.	N/A
<input type="checkbox"/> Description of off-site required feeder mains, booster pumping stations, and other water infrastructure that will be ultimately required to service proposed development, including financing, interim facilities, and timing of implementation.	N/A
<input type="checkbox"/> Confirmation that water demands are calculated based on the City of Ottawa Design Guidelines.	Appendix B
<input type="checkbox"/> Provision of a model schematic showing the boundary conditions locations, streets, parcels, and building locations for reference.	N/A

4.3 Development Servicing Report: Wastewater

Criteria	Location (if applicable)
<input type="checkbox"/> Summary of proposed design criteria (Note: Wet-weather flow criteria should not deviate from the City of Ottawa Sewer Design Guidelines. Monitored flow data from relatively new infrastructure cannot be used to justify capacity requirements for proposed infrastructure).	N/A
<input type="checkbox"/> Confirm consistency with Master Servicing Study and/or justifications for deviations.	N/A
<input type="checkbox"/> Consideration of local conditions that may contribute to extraneous flows that are higher than the recommended flows in the guidelines. This includes groundwater and soil conditions, and age and condition of sewers.	N/A
<input type="checkbox"/> Description of existing sanitary sewer available for discharge of wastewater from proposed development.	Section 5.2 Sanitary Sewer

<input type="checkbox"/> Verify available capacity in downstream sanitary sewer and/or identification of upgrades necessary to service the proposed development. (Reference can be made to previously completed Master Servicing Study if applicable)	N/A
<input type="checkbox"/> Calculations related to dry-weather and wet-weather flow rates from the development in standard MOE sanitary sewer design table (Appendix 'C') format.	N/A
<input type="checkbox"/> Description of proposed sewer network including sewers, pumping stations, and forcemains.	Section 5.2 Sanitary Sewer
<input type="checkbox"/> Discussion of previously identified environmental constraints and impact on servicing (environmental constraints are related to limitations imposed on the development in order to preserve the physical condition of watercourses, vegetation, soil cover, as well as protecting against water quantity and quality).	N/A
<input type="checkbox"/> Pumping stations: impacts of proposed development on existing pumping stations or requirements for new pumping station to service development.	N/A
<input type="checkbox"/> Forcemain capacity in terms of operational redundancy, surge pressure and maximum flow velocity.	N/A
<input type="checkbox"/> Identification and implementation of the emergency overflow from sanitary pumping stations in relation to the hydraulic grade line to protect against basement flooding.	N/A
<input type="checkbox"/> Special considerations such as contamination, corrosive environment etc.	N/A

4.4 Development Servicing Report: Stormwater Checklist

Criteria	Location (if applicable)
<input type="checkbox"/> Description of drainage outlets and downstream constraints including legality of outlets (i.e. municipal drain, right-of-way, watercourse, or private property)	Section 6.0 Stormwater Management
<input type="checkbox"/> Analysis of available capacity in existing public infrastructure.	N/A
<input type="checkbox"/> A drawing showing the subject lands, its surroundings, the receiving watercourse, existing drainage patterns, and proposed drainage pattern.	Pre & Post-Development Plans
<input type="checkbox"/> Water quantity control objective (e.g. controlling post-development peak flows to pre-development level for storm events ranging from the 2 or 5-year event (dependent on the receiving sewer design) to 100-year return period); if other objectives are being applied, a rationale must be included with reference to hydrologic analyses of the potentially affected subwatersheds, taking into account long-term cumulative effects.	Section 6.0 Stormwater Management
<input type="checkbox"/> Water Quality control objective (basic, normal or enhanced level of protection based on the sensitivities of the receiving watercourse) and storage requirements.	Section 6.0 Stormwater Management
<input type="checkbox"/> Description of the stormwater management concept with facility locations and descriptions with references and supporting information.	Section 6.0 Stormwater Management
<input type="checkbox"/> Set-back from private sewage disposal systems.	N/A
<input type="checkbox"/> Watercourse and hazard lands setbacks.	N/A
<input type="checkbox"/> Record of pre-consultation with the Ontario Ministry of Environment and the Conservation Authority that has jurisdiction on the affected watershed.	N/A
<input type="checkbox"/> Confirm consistency with sub-watershed and Master Servicing Study, if applicable study exists.	N/A
<input type="checkbox"/> Storage requirements (complete with calculations) and conveyance capacity for minor events (1:5-year return period) and major events (1:100-year return period).	Appendix F

<input type="checkbox"/> Identification of watercourses within the proposed development and how watercourses will be protected, or, if necessary, altered by the proposed development with applicable approvals.	Site Grading, Drainage, Sediment & Erosion Control Plan
<input type="checkbox"/> Calculate pre-and post development peak flow rates including a description of existing site conditions and proposed impervious areas and drainage catchments in comparison to existing conditions.	Section 6.0 Stormwater Management Appendix F
<input type="checkbox"/> Any proposed diversion of drainage catchment areas from one outlet to another.	Section 6.0 Stormwater Management
<input type="checkbox"/> Proposed minor and major systems including locations and sizes of stormwater trunk sewers, and stormwater management facilities.	Section 6.0 Stormwater Management
<input type="checkbox"/> If quantity control is not proposed, demonstration that downstream system has adequate capacity for the post-development flows up to and including the 100-year return period storm event.	Appendix A
<input type="checkbox"/> Identification of potential impacts to receiving watercourses	N/A
<input type="checkbox"/> Identification of municipal drains and related approval requirements.	N/A
<input type="checkbox"/> Descriptions of how the conveyance and storage capacity will be achieved for the development.	Section 6.0 Stormwater Management
<input type="checkbox"/> 100-year flood levels and major flow routing to protect proposed development from flooding for establishing minimum building elevations (MBE) and overall grading.	Site Grading, Drainage, Sediment & Erosion Control Plan (C101)
<input type="checkbox"/> Inclusion of hydraulic analysis including hydraulic grade line elevations.	N/A

<input type="checkbox"/> Description of approach to erosion and sediment control during construction for the protection of receiving watercourse or drainage corridors.	Section 7.0 Sediment & Erosion Control
<input type="checkbox"/> Identification of floodplains – proponent to obtain relevant floodplain information from the appropriate Conservation Authority. The proponent may be required to delineate floodplain elevations to the satisfaction of the Conservation Authority if such information is not available or if information does not match current conditions.	N/A
<input type="checkbox"/> Identification of fill constraints related to floodplain and geotechnical investigation.	N/A

4.5 Approval and Permit Requirements: Checklist

The Servicing Study shall provide a list of applicable permits and regulatory approvals necessary for the proposed development as well as the relevant issues affecting each approval. The approval and permitting shall include but not be limited to the following:

Criteria	Location (if applicable)
<input type="checkbox"/> Conservation Authority as the designated approval agency for modification of floodplain, potential impact on fish habitat, proposed works in or adjacent to a watercourse, cut/fill permits and Approval under Lakes and Rivers Improvement Act. The Conservation Authority is not the approval authority for the Lakes and Rivers Improvement Act. Where there are Conservation Authority regulations in place, approval under the Lakes and Rivers Improvement Act is not required, except in cases of dams as defined in the Act.	N/A
<input type="checkbox"/> Application for Certificate of Approval (CofA) under the Ontario Water Resources Act.	N/A
<input type="checkbox"/> Changes to Municipal Drains.	N/A
<input type="checkbox"/> Other permits (National Capital Commission, Parks Canada, Public Works and Government Services Canada, Ministry of Transportation etc.)	N/A

4.6 Conclusion Checklist

Criteria	Location (if applicable)
<input type="checkbox"/> Clearly stated conclusions and recommendations	Section 8.0 Summary Section 9.0 Recommendations
<input type="checkbox"/> Comments received from review agencies including the City of Ottawa and information on how the comments were addressed. Final sign-off from the responsible reviewing agency.	All are stamped
<input type="checkbox"/> All draft and final reports shall be signed and stamped by a professional Engineer registered in Ontario	All are stamped