

Legend

Notes

5	RE-ISSUED FOR CITY REVIEW	CA	KP	22.10.17
4	RE-ISSUED FOR CITY REVIEW	CA	KP	22.04.07
3	ISSUED FOR CITY REVIEW	CA	KP	22.01.28
2	ISSUED FOR COORDINATION	CTL	ILL	20.10.06
1	ISSUED FOR COORDINATION	CTL	ILL	20.08.17
Revision		By	Appd.	YY.MM.DD
File Name: 160410274-L		CTL	ILL	CTL
		Dwn.	Chkd.	Dsgn.

Permit-Seal



Client/Project
LASALLE INVESTMENT MANAGEMENT
22 ADELAIDE STREET WEST, 26TH FLOOR

HOLLAND CROSS
1560 SCOTT STREET
OTTAWA, ON

Title
LANDSCAPE DETAILS 2

Project No.	Scale
160410274	VARIES
Drawing No.	Sheet
L301	4 of 5
Revision	5

1600 SERIES

MBR-1600-00008
Legacy # SCBR1600-S



- Bike Racks to be 'MBR-1600-00008' by Maglin or approved equivalent
- Colour: Metal: Black; Slats: Wood
- Finish: Matte
- Installation: Surface Mounted
- Shop drawings of planters to be provided for approval by Landscape Architect prior to place order.

DESCRIPTION: 1600 Series - SC Bike Rack: Cast Aluminum, Surface Mount, 2 Bike Configuration

FINISH: The Maglin Powdercoat System provides a durable finish on all metal surfaces.

INSTALLATION: The bike rack is delivered pre-assembled. It is available with either a surface mount or direct burial installation option.

TO SPECIFY: Select MBR-1600-00008
Choose:
- Powdercoat Color

HEIGHT: 25.19" (63.98cm) LENGTH: 27.62" (70.17cm) WIDTH: 3.375" (8.375cm) WEIGHT: 16.3lbs (8.3kg)

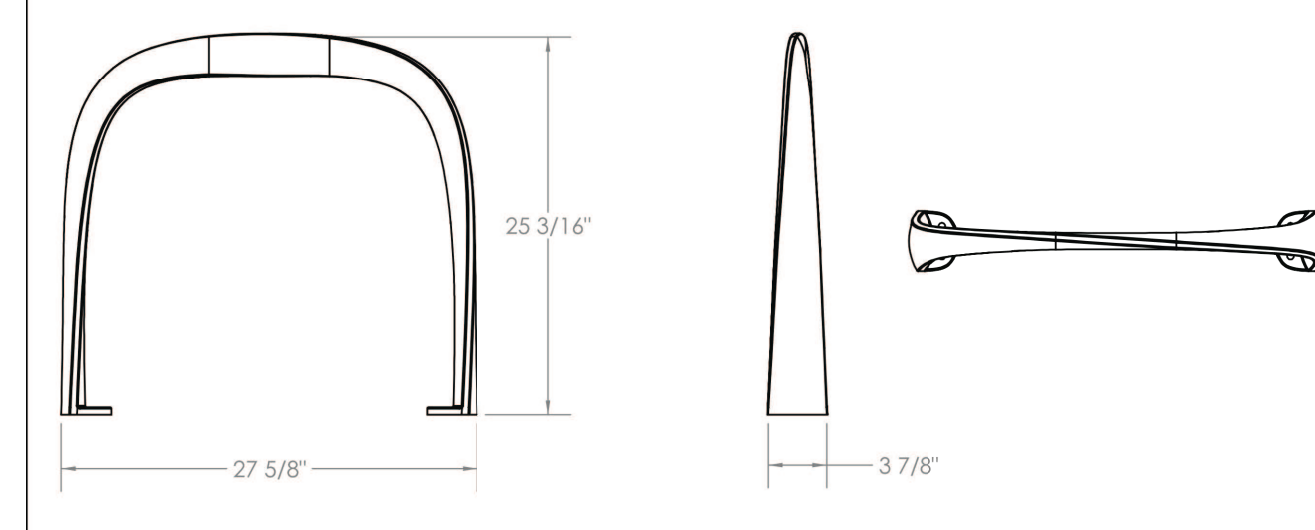

3 BIKE RACK
N.T.S.

1200 SERIES

MBE-1200-00018
Legacy # MLB1200-PCS



- Bench to be 'MTE-1200-00018' with end arm rests by Maglin or approved equivalent
- Colour: Metal: Black; Slats: Wood
- Finish: Matte
- Installation: Surface Mounted
- Shop drawings of planters to be provided for approval by Landscape Architect prior to place order.

MATERIALS: Bench ends are made from solid cast aluminum. The seat employs High Density Paper Composite - Sandstone color.

FINISH: All steel components are protected with E-Coat rust proofing. The Maglin Powdercoat System provides a durable finish on all metal surfaces.

INSTALLATION: The bench is delivered pre-assembled. Holes (0.5") are provided in each foot for securing to base.

TO SPECIFY: Select MBE-1200-00018
Choose:
- Powdercoat Color

HEIGHT: 32.25" (81.8cm) LENGTH: 70" (177.8cm) DEPTH: 22.38" (56.8cm) WEIGHT: 110.3lbs (50kg)

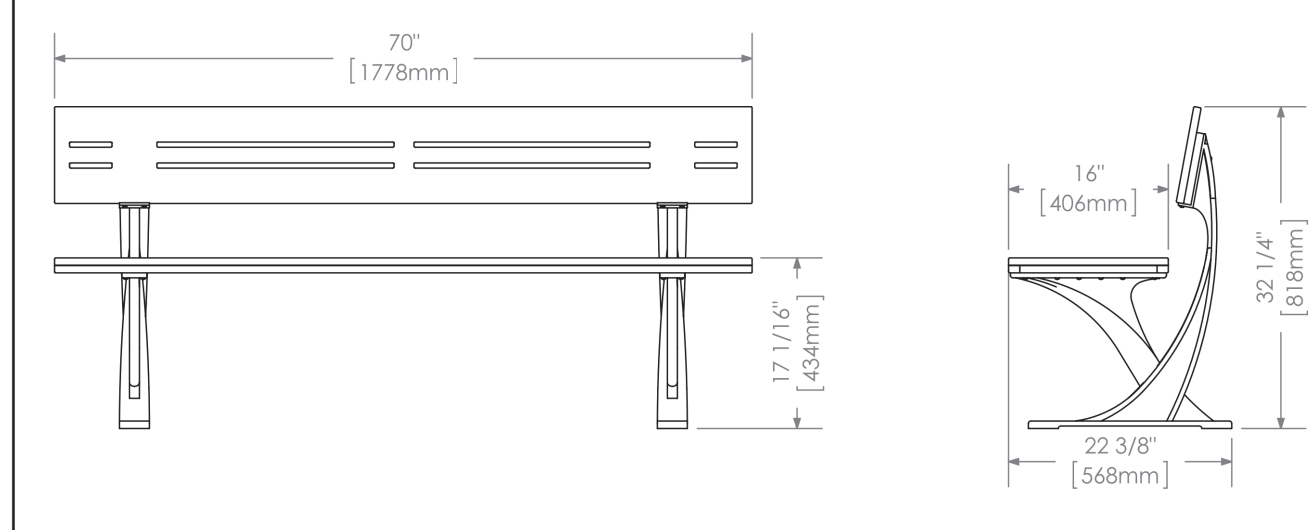

2 BENCH
N.T.S.

MUG

MTR-2900-00008 WASTE/RECYCLE



- Waste Receptacle to be 'MTR-2900-00008' by Maglin or approved equivalent
- Colour: Metal: Black; Slats: Wood
- Finish: Matte
- Installation: Surface Mounted
- Shop drawings of planters to be provided for approval by Landscape Architect prior to place order.

DESCRIPTION: 2900 Series - MUG Trash Receptacle: Steel Frame and Lid, Steel Slats, Side Opening, 1 x 32 Gallon Polyethylene Liner - Black Color

FINISH: All steel components are protected with E-Coat rust proofing. The Maglin Powdercoat System provides a durable finish on all metal surfaces.

INSTALLATION: The trash receptacle is delivered pre-assembled. 3 holes (9/16") are provided in each mounting foot for securing to base.

TO SPECIFY: Select MTR-2900-00008
Choose:
- Powdercoat Color - Vinyl Graphics

HEIGHT: 32 1/4" (81.9cm) WIDTH: 29 1/2" (74.9cm) DIAMETER: 25" (63.5cm) WEIGHT: 188.2lbs (85.4kg)

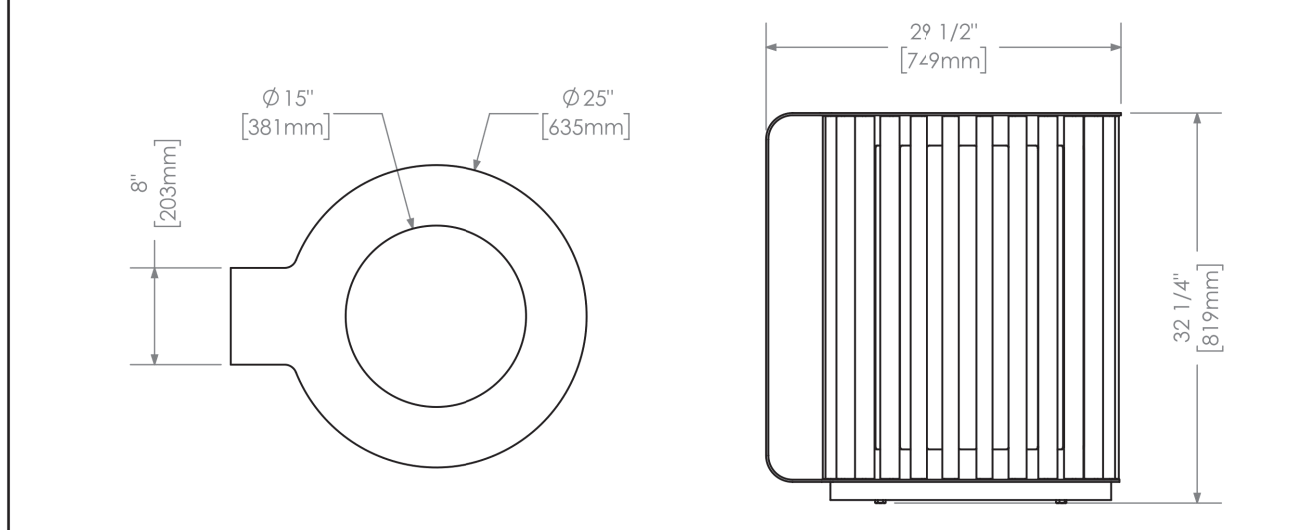

1 WASTE RECEPTACLE BY MAGLIN
N.T.S.

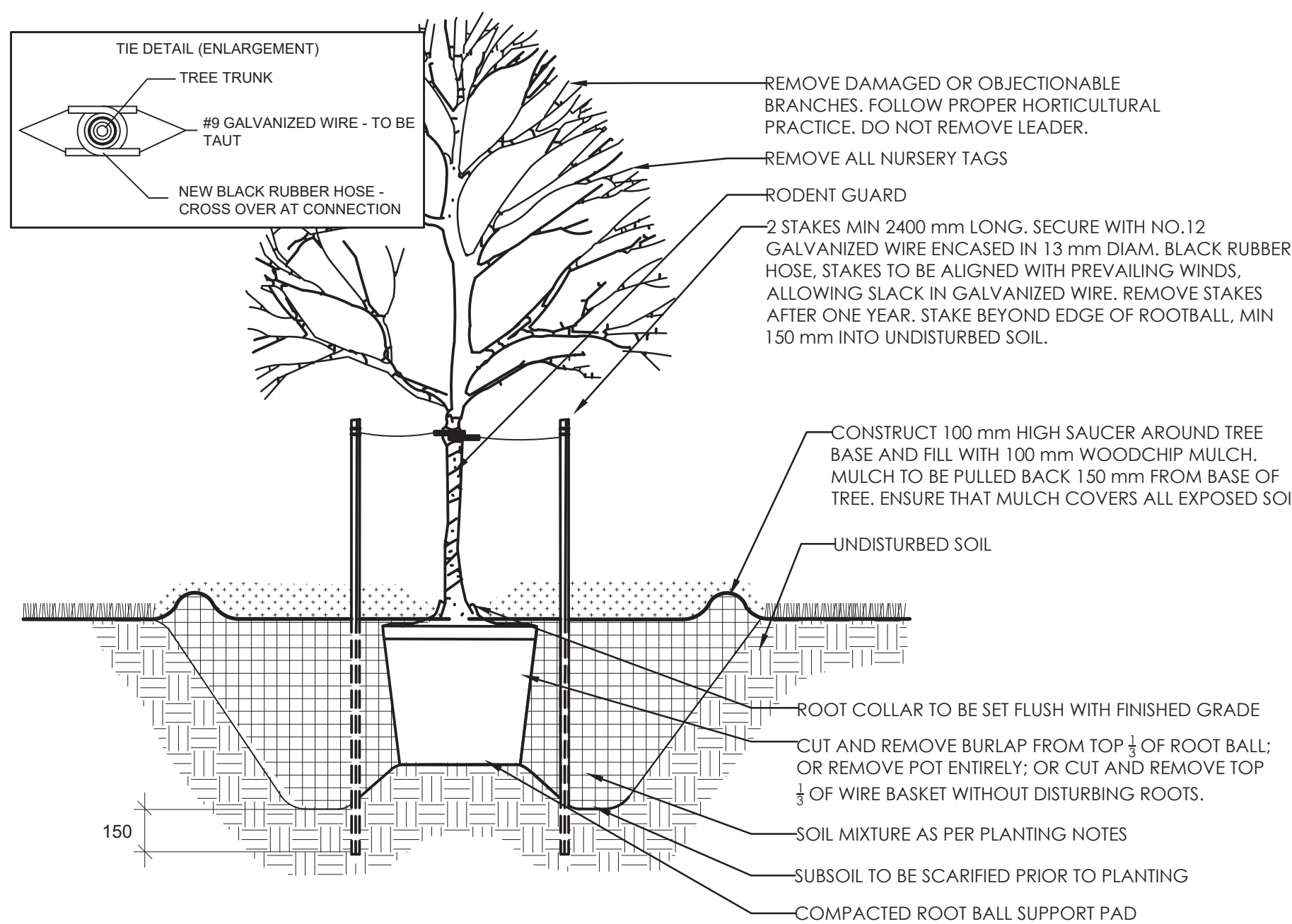

4 DECIDUOUS TREE PLANTING
N.T.S.

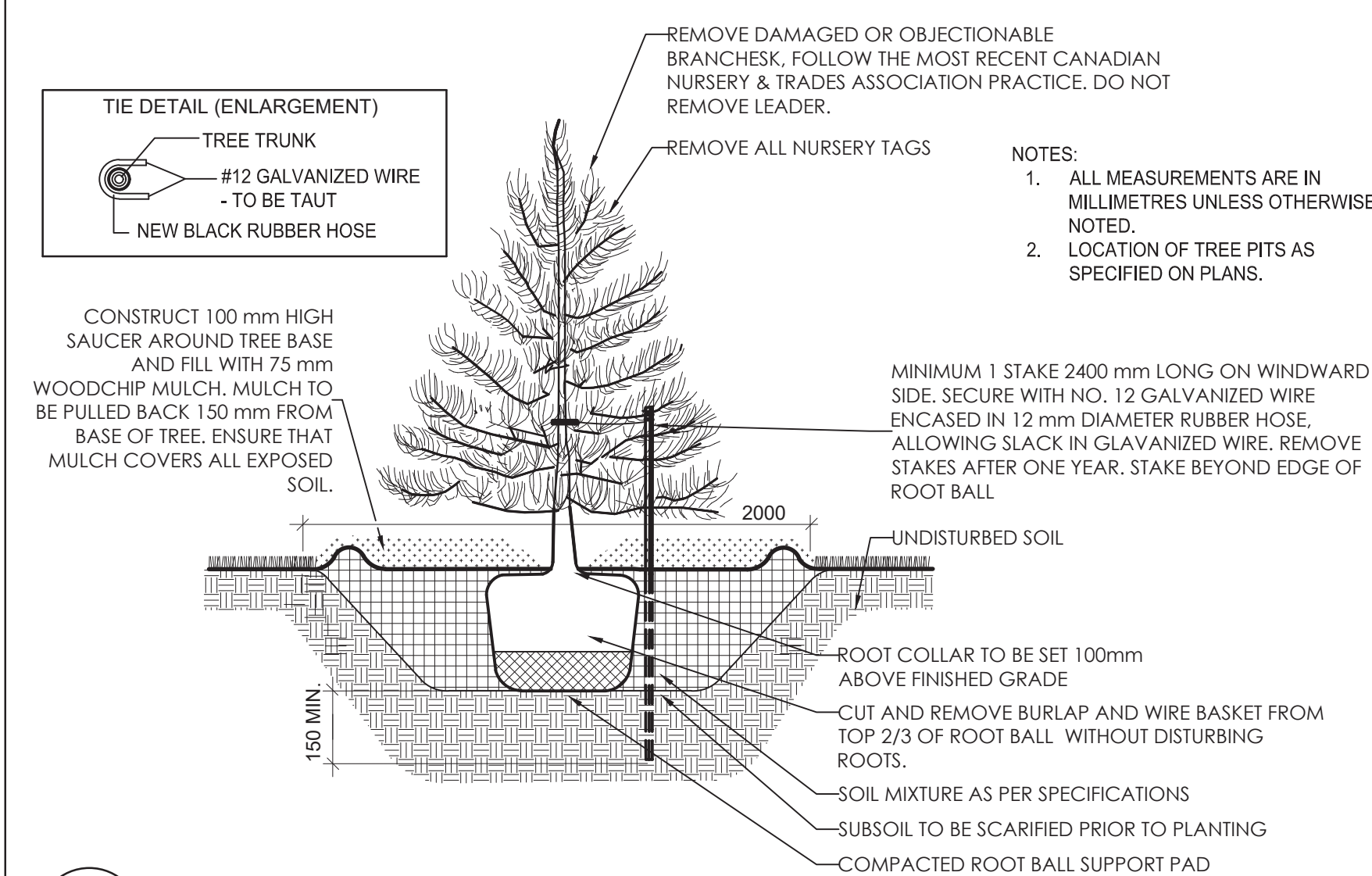

5 CONIFEROUS TREE PLANTING DETAIL
N.T.S.

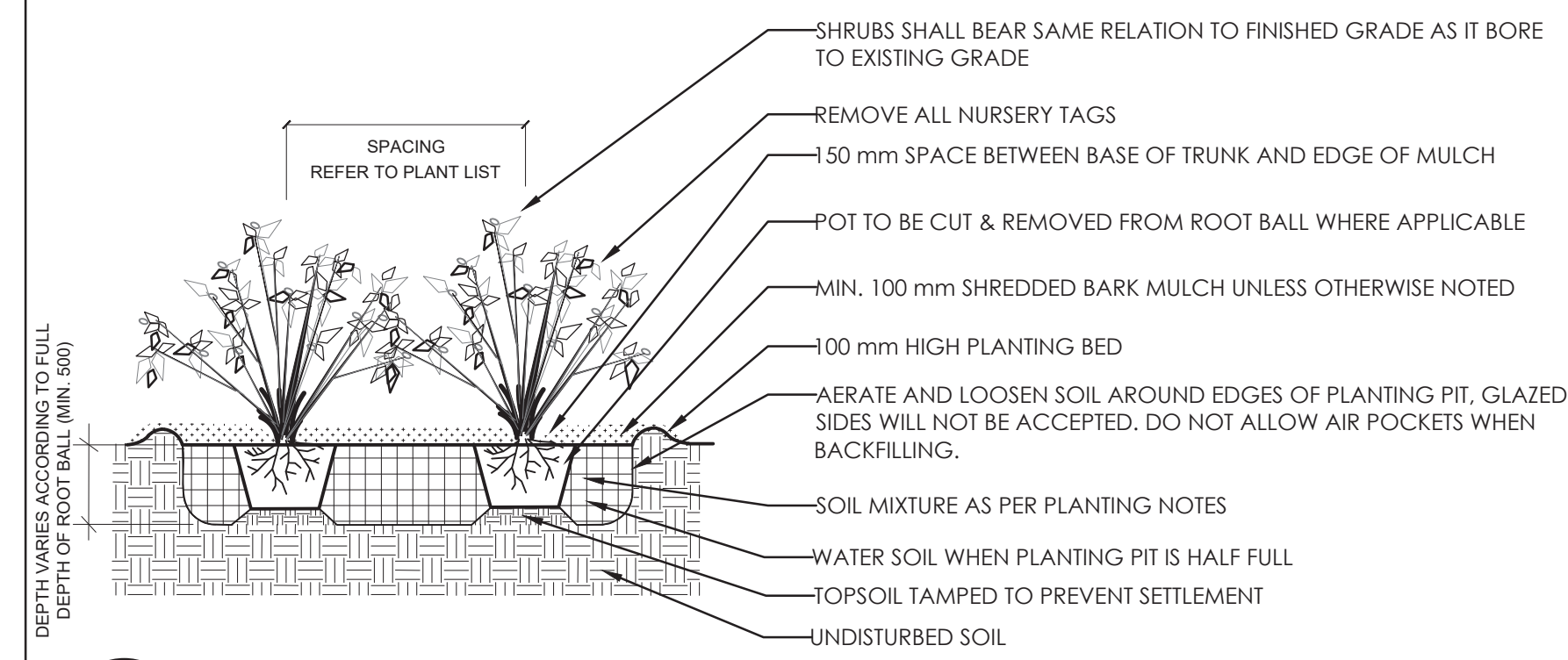

6 SHRUB PLANTING
N.T.S.

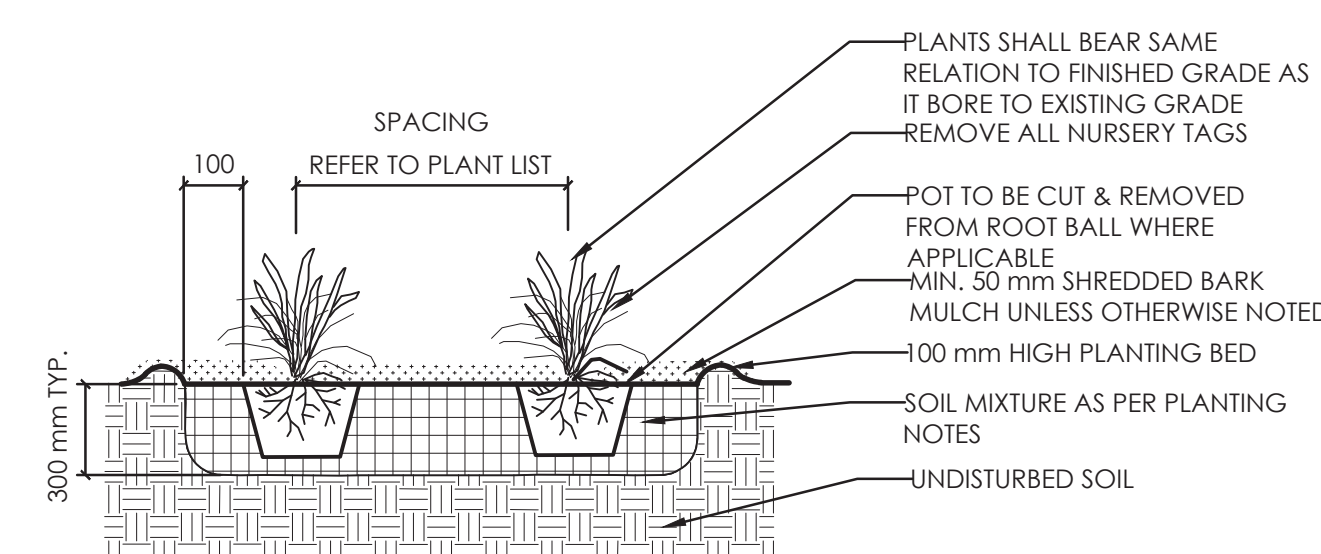

7 PERENNIAL AND GRASSES PLANTING
N.T.S.

3/22/22 10:17:11 AM ORIGINAL SHEET - ARCH D