

KEY	QTY	BOTANICAL NAME	COMMON NAME	SIZE	COMMENTS
DECIDUOUS TREES					
AC	4	Amaranthus canadensis	Serviceberry	50mm CAL	W.B.
SV	2	Syringa vulgaris	Tree Lilac	50mm CAL	W.B.
PERENNIALS					
epw	30	Echinacea purpurea 'PowWow Wildberry'	Wildberry Coneflower	1 gal	Potted
epw	37	Echinacea purpurea 'PowWow White'	PowWow White Coneflower	1 gal	Potted
ls	87	Liatris spicata	Dense Blazing Star	1 gal	Potted
GRASSES					
ca	10	Callamagrostis stricta	Neglected Reed Grass	2 gal	Potted

G. Wildman

GERALDINE WILDMAN
ACTING MANAGER, DEVELOPMENT REVIEW EAST
PLANNING, REAL ESTATE & ECONOMIC DEVELOPMENT
DEPARTMENT, CITY OF OTTAWA

APPROVED
By Geraldine Wildman at 6:13 pm, Oct 28, 2022

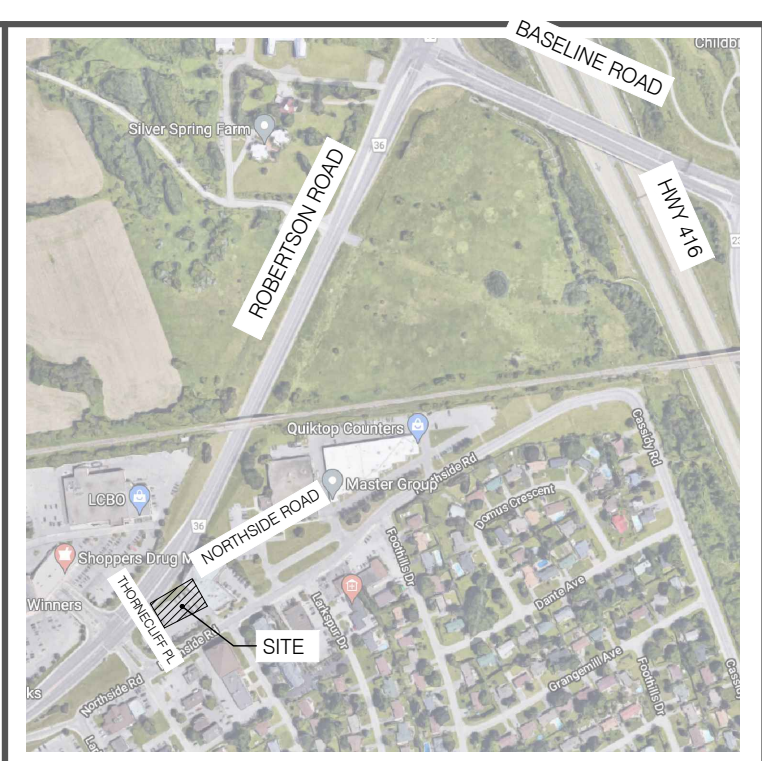

- L1-1 GENERAL NOTES**
- All general site information and conditions compiled from architect's and engineer's plans and surveys.
 - Do not scale this drawing.
 - Report any discrepancies prior to commencing work. No responsibility is born by the Landscape Architect for unknown subsurface conditions.
 - Reinstate all areas and items damaged as a result of construction activities to the satisfaction of the Landscape Architect.
 - Drawing may not be used for construction until signed by Landscape Architect as issued for construction.
 - The accuracy of the position of utilities is not guaranteed.
 - Individual utility co. must be contacted for confirmation of utility existence and location prior to digging.
 - This drawing is an instrument of service and requires the permission of the Landscape Architect for use. Copyright is reserved by the Landscape Architect, David M. Lashley.

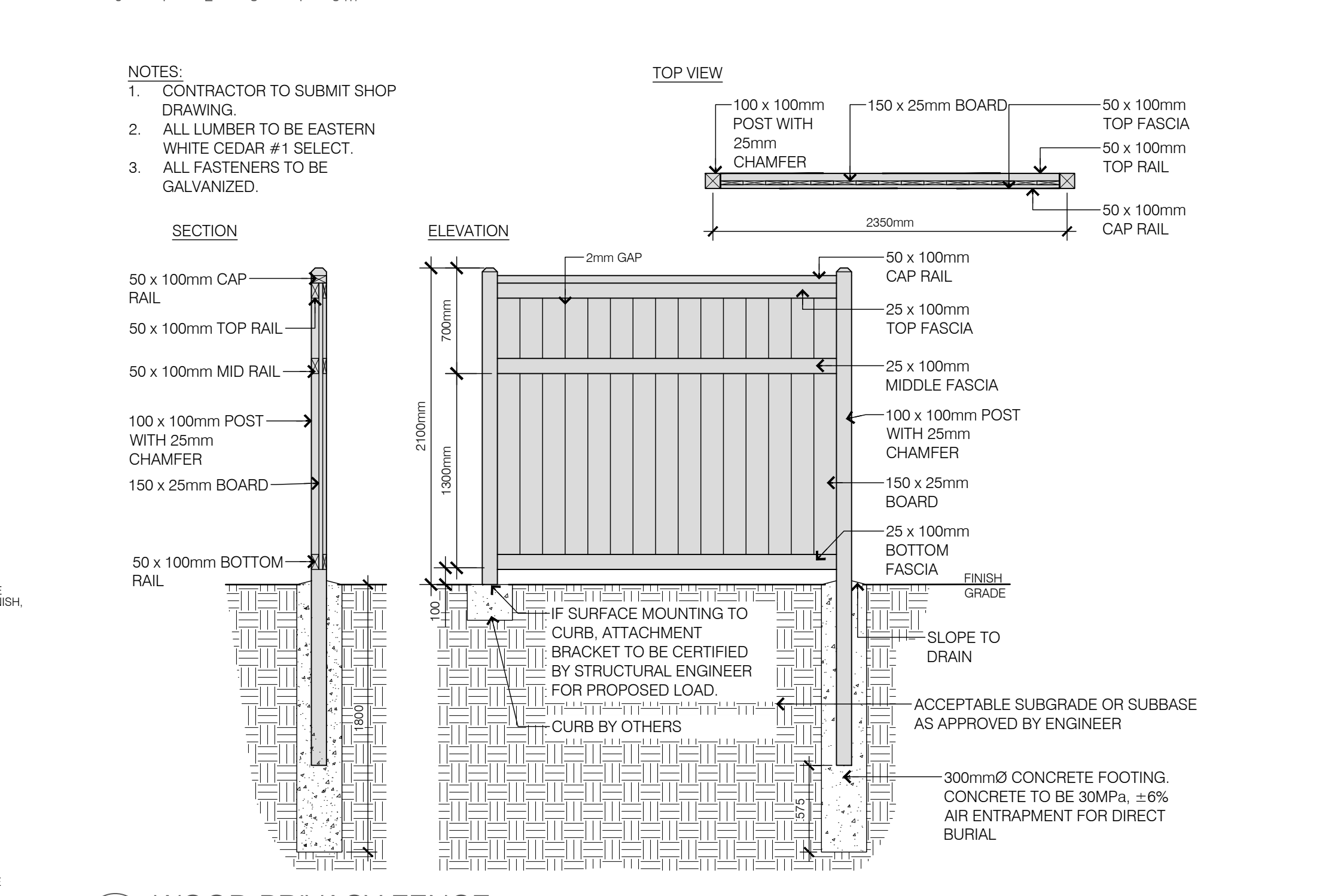
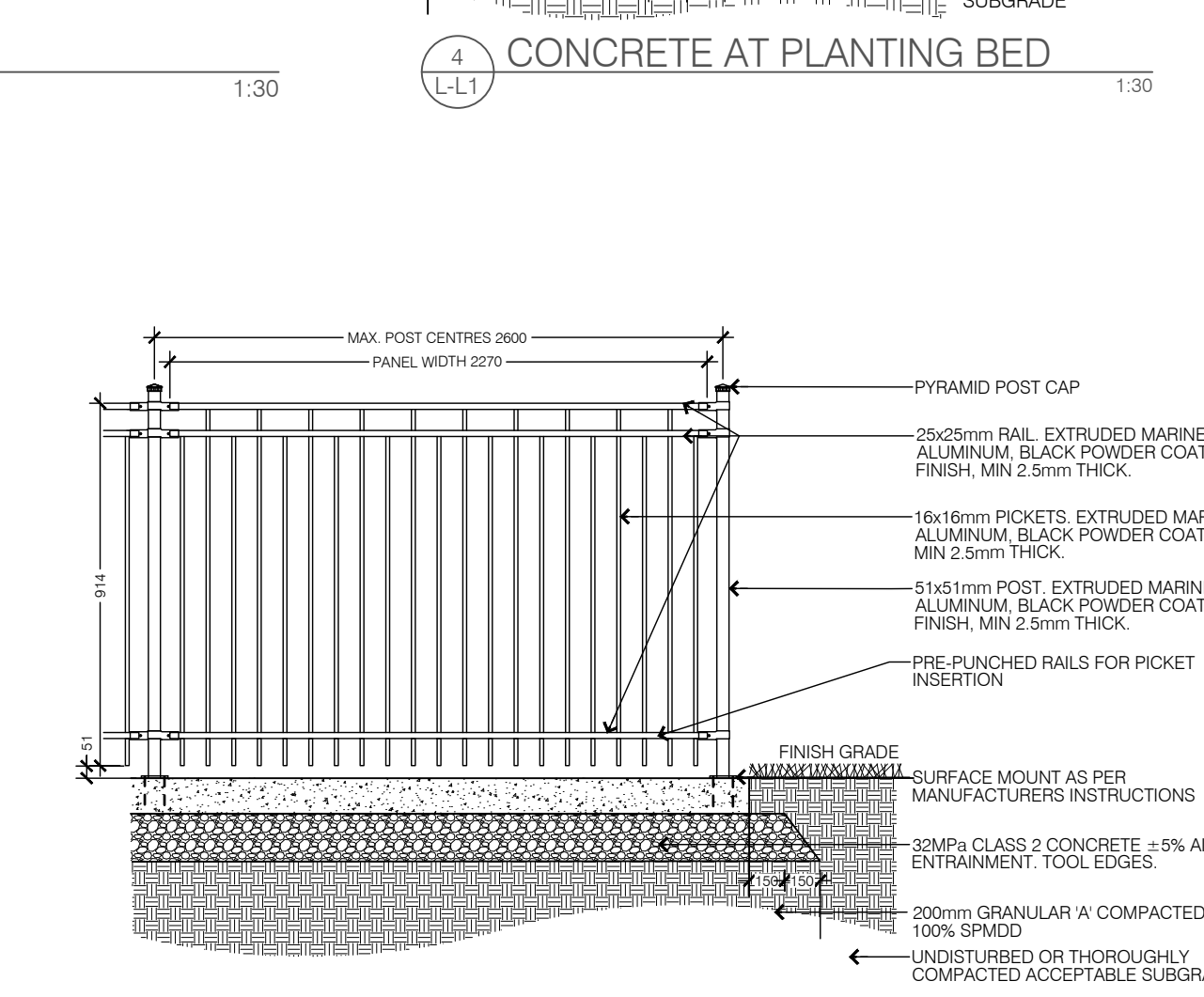
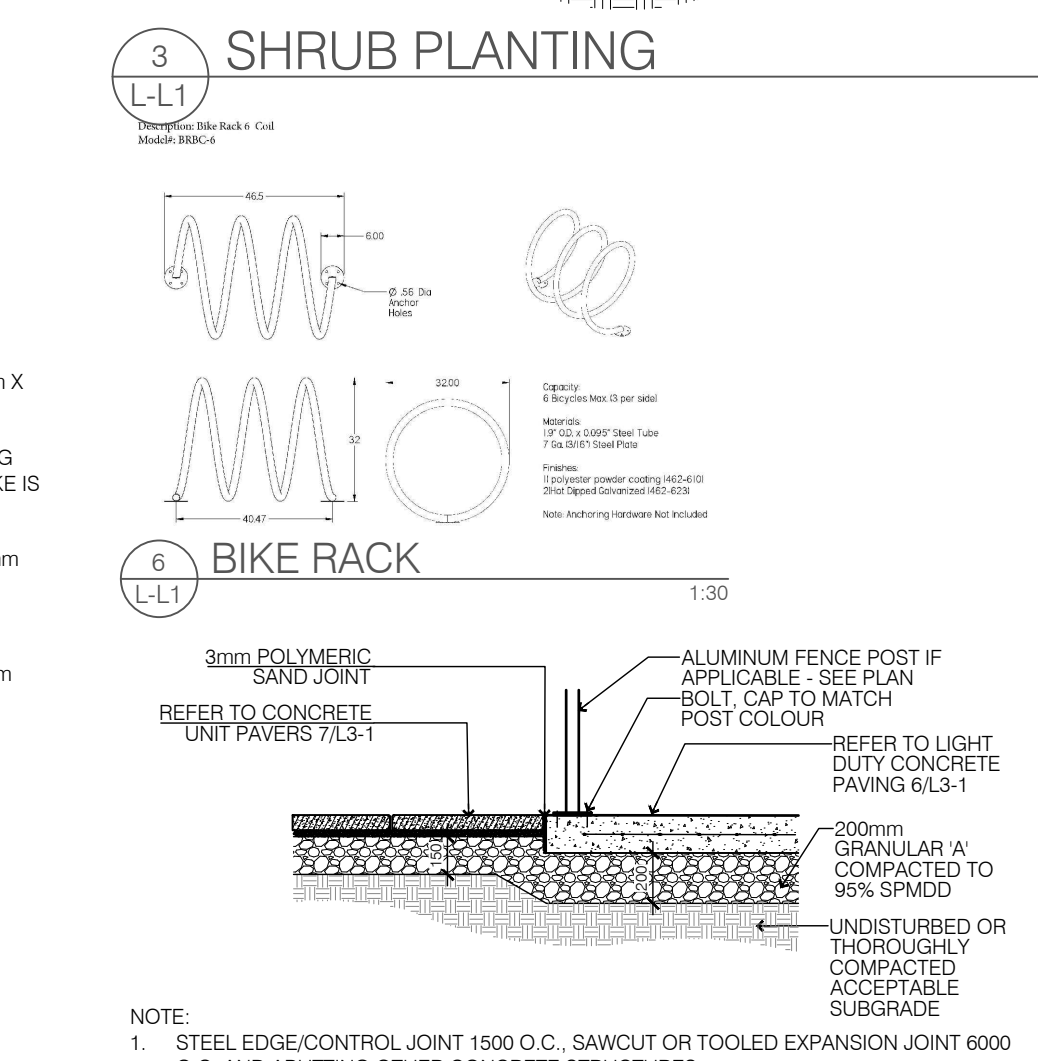
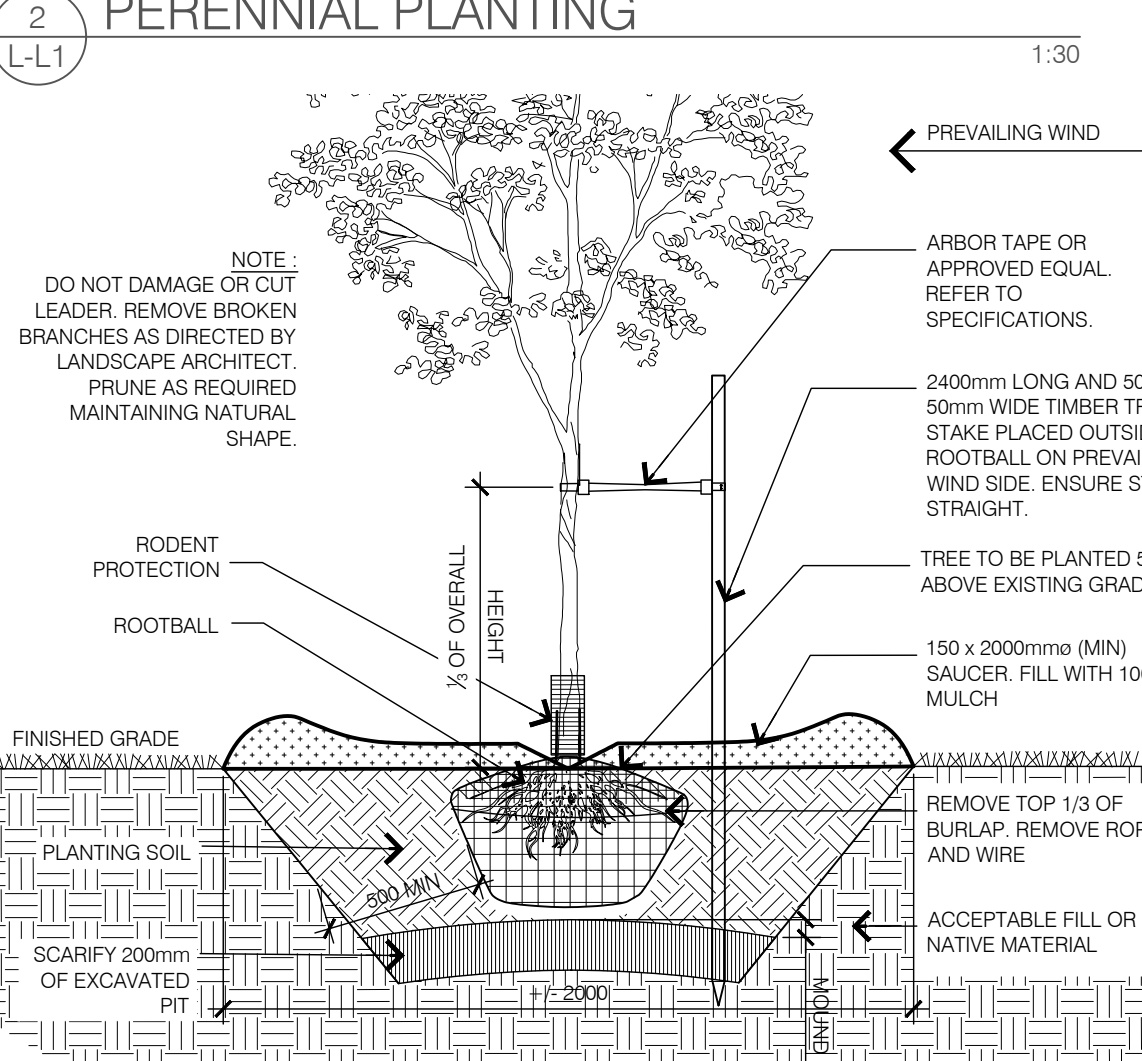
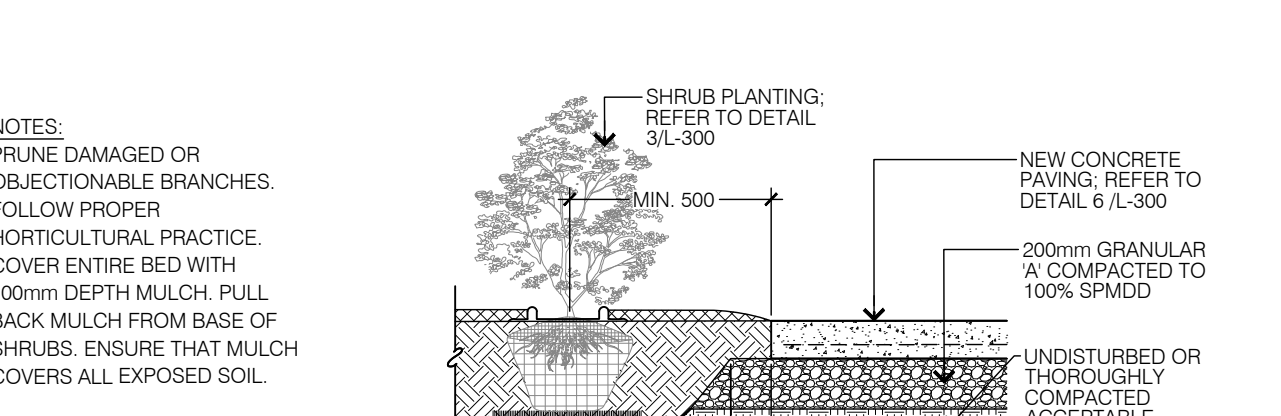
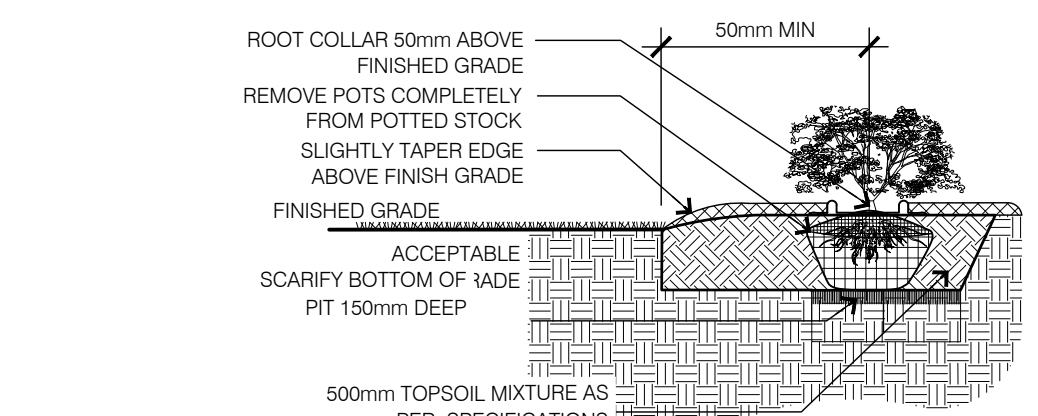
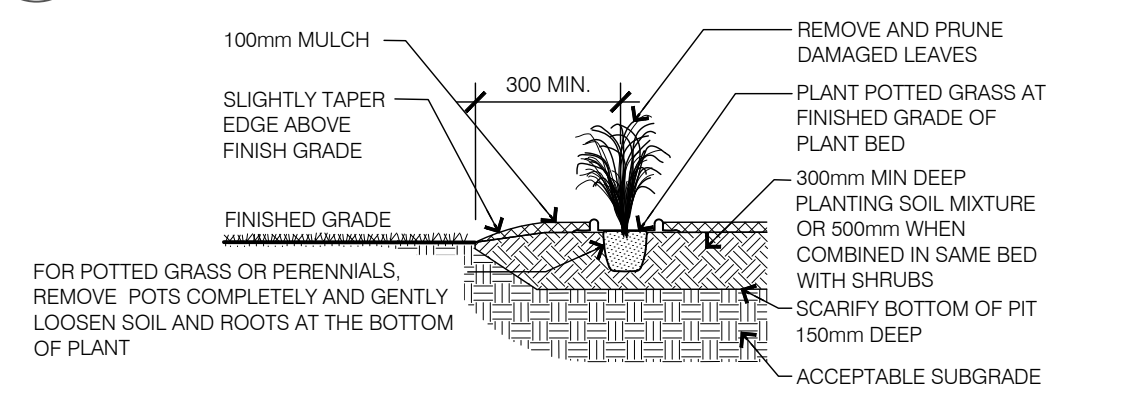
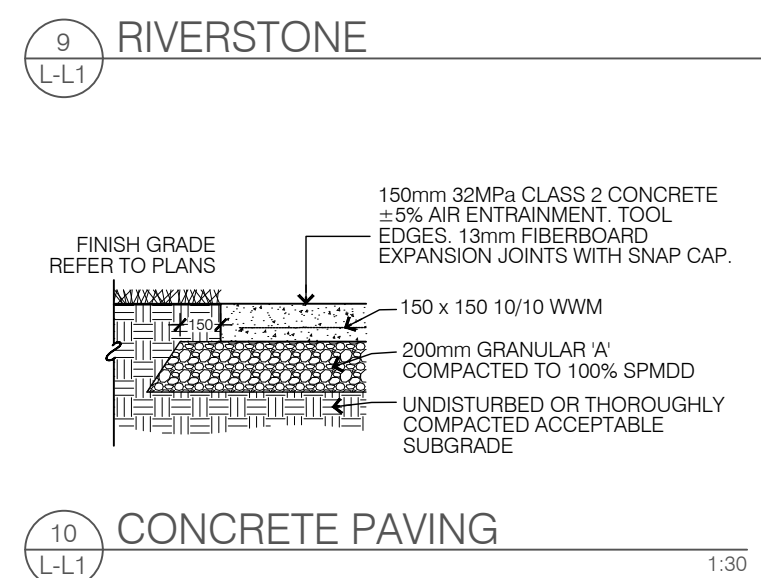
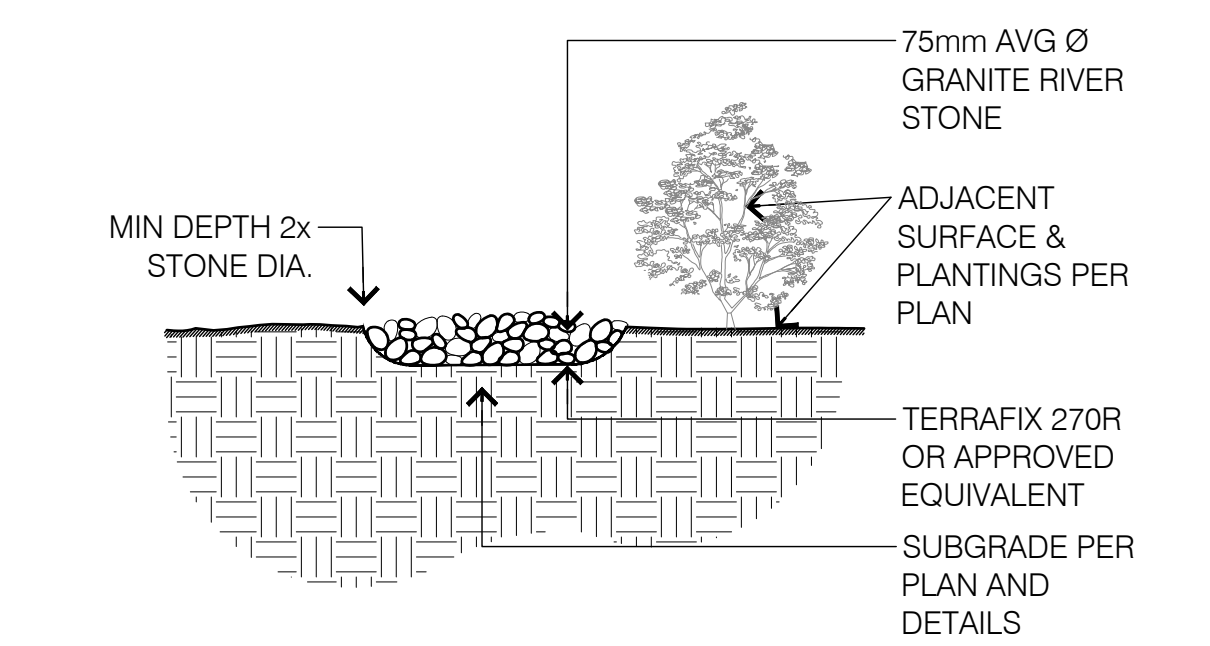

NO.	DATE	DESCRIPTION
4	2022-09-01	ISSUED FOR PERMIT
3	2022-04-29	ISSUED FOR SPA
2	2021-12-15	ISSUED FOR COORDINATION
1	2021-12-13	ISSUED FOR COORDINATION

NO. DATE DESCRIPTION

SEAL:

NORTH:

250-260 GLADSTONE AVENUE
OTTAWA, ON K1Y 3E8
613 233 8079
613 233 4021
www.lashley.ca
E: info@lashley.ca

CONSULTANT:
LASHLEY + ASSOCIATES
LANDSCAPE ARCHITECTURE AND SITE ENGINEERING

PROJECT:
42 NORTHSIDE ROAD
BELLS CORNERS
42 NORTHSIDE ROAD, NEPEAN
OTTAWA, ON, K2H 5Z4

DRAWING TITLE:
LANDSCAPE PLAN

DATE: 2021-07-26
SCALE: AS SHOWN
DRAWN BY: NG-RP
LA PROJECT NO.: 21826-1

DRAWING NO.:
L1-1

D07-12-22-0015