

ZIBI BLOCK 204

Site Servicing Report

City of Ottawa, Ontario



CIMA+ file number: A000931
August 31, 2022
Revision No. 1

ZIBI BLOCK 204

Site Servicing Report

City of Ottawa, Ontario

Prepared by:



Julien Sauvé, P. Eng.
P.E.O. membership number: 100200100



Verified by:



André Chaumont, P.Eng.
P.E.O. membership number: 90409194



240 Catherine Street, Suite 110, Ottawa, ON
Canada K2P 2G8

CIMA+ file number: A000931
August 31, 2022
Revision No. 1

Table of Contents

1.	Introduction	1
1.1	Site Description and Proposed Development	1
1.2	Review of Available Background Documentation	2
1.3	Existing Infrastructure.....	3
1.4	Consultation and Permits	3
2.	Water Servicing	4
2.1	Existing Condition	4
2.2	Water Supply Design Criteria	5
2.3	Proposed Water Supply Servicing and Calculations	7
2.4	Water Supply Summary and Conclusions	9
3.	Sanitary Servicing.....	9
3.1	Existing Conditions.....	9
3.2	Sanitary Servicing Design Criteria.....	10
3.3	Proposed Sanitary Servicing and Calculations	11
3.4	Sanitary Servicing Summary and Conclusions	12
4.	Storm Servicing and Stormwater Management	13
4.1	Existing Conditions.....	13
4.2	Storm Servicing Strategy and Design Criteria.....	14
4.3	Proposed Storm Servicing and Stormwater Management Design and Calculations	14
4.4	Storm Servicing and Stormwater Management Summary and Conclusions	16
5.	Conclusion	16

List of Tables

Table 2-1: Water Supply Design Criteria.....	6
Table 2-2: Water Demands Block 204	7
Table 2-3: Water Demands Block 204, 211, 206, 207, 205A, 208, EO.....	7
Table 2-4: Watermain Boundary Conditions.....	8
Table 3-1: Sanitary Peak Flow Determination Design Criteria.....	11
Table 3-2: Block 204 Peak Sanitary Flows.....	12
Table 4-1: Peak Release Flows – Existing Site	14
Table 4-2: Post-development Flow Rate	15

List of Figures

Figure 1-1: Site Location - Plan View	1
Figure 1-2: Conceptual Site Plan.	2

Figure 2-1 Existing Watermain Network..... 5
Figure 3-1 Existing Sanitary Network..... 10
Figure 4-1 Existing Storm Network..... 13

List of Appendices

- Appendix A Correspondence
- Appendix B Water Supply Calculations
- Appendix C Wastewater Collection Calculations
- Appendix D Stormwater Management Calculations
- Appendix E Drawings
- Appendix F ECA Application
- Appendix G Phase 1 (DSEL Report)

1. Introduction

CIMA+ was retained by Windmill Dream on holdings LP to prepare a Site Servicing and Stormwater Management Report for the proposed construction of mixed uses (retail and residential) high-rise building on Chaudière Island, Ottawa, Ontario henceforth referred to as ZIBI – Block 204.

The purpose of this assessment is to confirm that the proposed development can be adequately serviced by the existing municipal and private infrastructure (water, sanitary, and storm) surrounding the site. This assessment shall be used in support of the application for Site Plan Control.

1.1 Site Description and Proposed Development

The site is located on Chaudière Island, Ottawa on the west side of Booth Street and Chaudière Bridge. (Refer to **Figure 1** below). As an update to the current status, the overall ZIBI site received site plan approval on May 2018 following the submission of a Master Servicing report from the engineering consulting firm David Schaeffer Engineering Ltd (DSEL). In August 2018, DSEL submitted a Functional Servicing and Storm Water Management Report – Phase 1 which includes Block 204. This site servicing report was prepared respecting the approval already confirmed for the aforementioned Phase 1.

Figure 1-1: Site Location - Plan View.

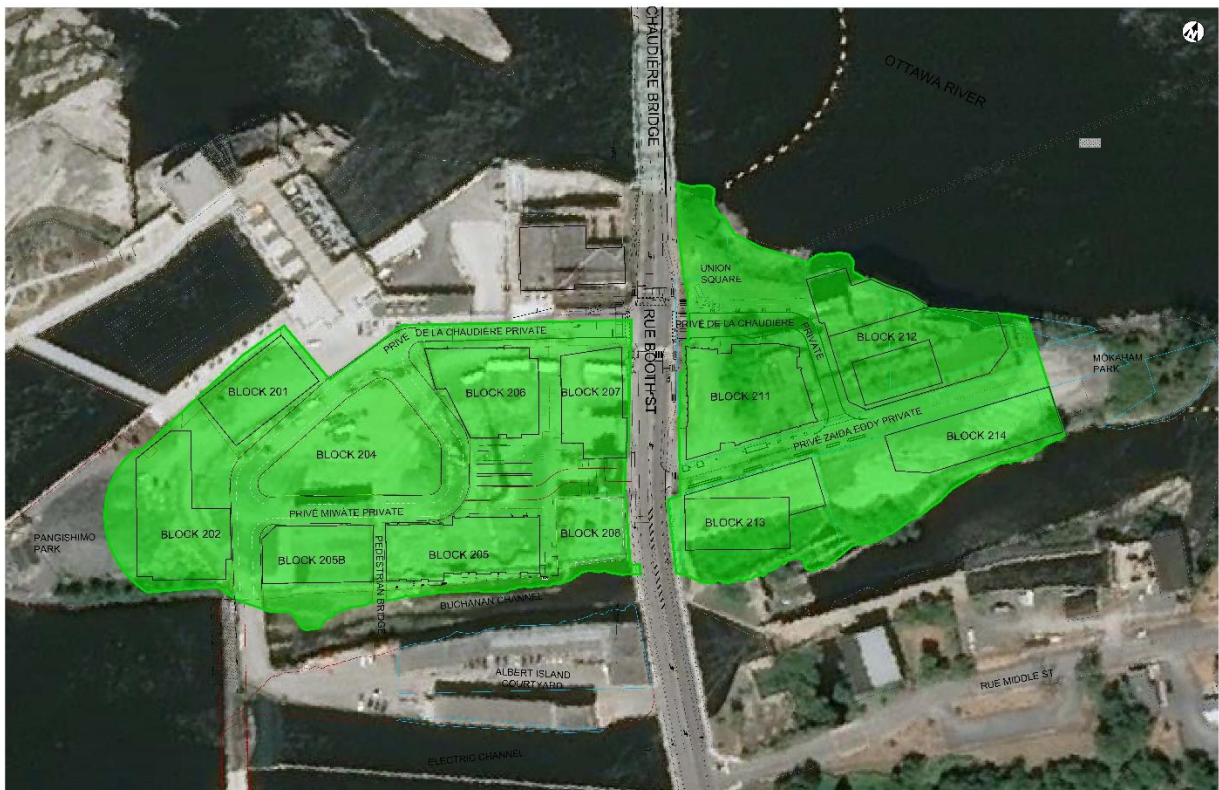

ZIBI – Block 204 is comprised of twenty-two (22) storey building including one level of underground parking surrounded with woonerf landscaping street type design. The building footprint is about +/- 2700 m² for the first level, over an underground parking of 4200 m². The underground parking has significant larger surface than the building footprint since it is connected with other underground parking infrastructure (205A and 206) to the east and design to include further underground parking connections. Each additional building floor varies between 775 m² and 1225 m². Refer to **Figure 2** for a conceptual site plan of the proposed development (prepared by Neuf Architects Inc/CSW Landscape Architecture).

Figure 1-2: Conceptual Site Plan.

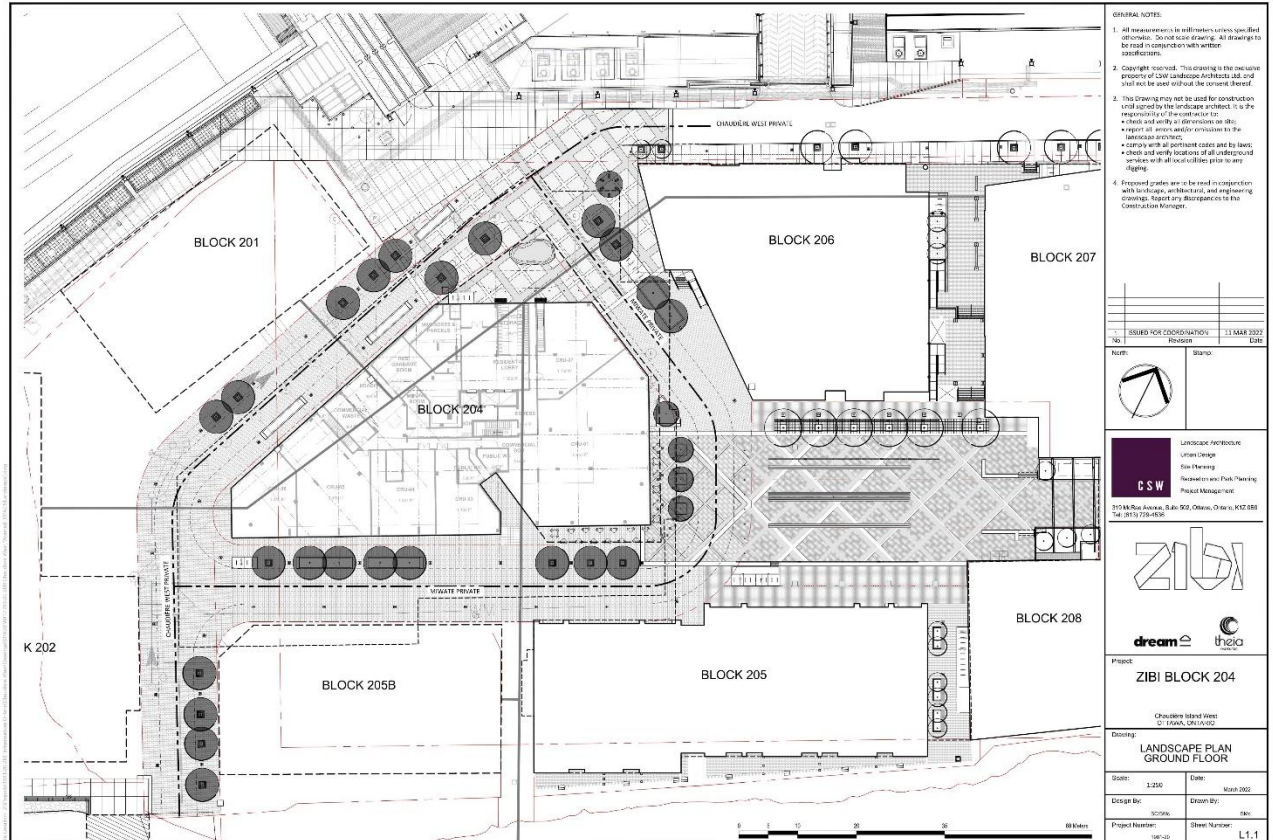

1.2 Review of Available Background Documentation

The following design guidelines have been used to estimate the theoretical servicing requirements for the proposed development; while geoOttawa, a detailed topographic survey prepared by Stantec, and the available as-built drawings provided by the client and City of Ottawa Information Centre have been used to determine the existing municipal services location, size, material, and inverts fronting the site.

- + Ottawa Sewer Design Guidelines (October 2012), as amended by all applicable Technical Bulletins;
- + Ottawa Design Guidelines – Water Distribution (2010), as amended by all applicable Technical Bulletins;
- + Ministry of the Environment Design Guidelines for Sewage Works (2008).

- + Ministry of the Environment Stormwater Management Planning and Design Manual (2003).
- + Ministry of the Environment Design Guidelines for Drinking-Water Systems (2008); and
- + Fire Underwriters Survey (FUS) Water Supply for Public Fire Protection (1999).

1.3 Existing Infrastructure

Chaudière Island is presently in the course of re-development. On the west side of the island, the construction of Buildings 205A and 208 (see Figure 1) were undertaken, now completed, and occupied. Buildings 206 and 207 (see Figure 1) are presently through construction. They are presently completing the underground parking and should be ready for occupancy 2024.

As identified using the detailed topographic survey completed by Stantec Geomatics Ltd, geoOttawa and the available Utility Record Drawings provided by the City of Ottawa Information Centre, the following municipal infrastructure are available within the right-of-way fronting the proposed development site (refer to **Appendix E** for Existing Conditions Plan). The municipal services collectors on Booth and Chaudière Streets are all constructed and connected with the City of Ottawa networks. A new pumping station, to be located on the east side of Booth Street on Chaudière Island, is presently through approvals.

Booth Street

- 203mm diameter ductile iron watermain (North of Middle Street);
- 305mm diameter PVC watermain (South of Middle Street);
- 250mm diameter sanitary sewer.
- 525mm diameter storm sewer.

Chaudière Private Street

- 203mm diameter ductile iron watermain;
- 250mm diameter sanitary sewer;
- 450mm diameter storm sewer.

1.4 Consultation and Permits

In response to the pre-consultation requirements defined in the City's Development Servicing Study Checklist, the following agencies were consulted in support of the preparation of this report. The Development Servicing Study Checklist as well as all relevant correspondence with the consulted agencies can be found in **Appendix A**.

City of Ottawa

The City of Ottawa Information Centre was contacted to obtain any Reports, Studies, Engineering, and/or Utility Plans including sanitary sewer, storm sewer, watermain, gas, etc. within or adjacent to the site location. The available as-built plans were obtained, while no existing reports or studies were available. Given a detailed utility survey was previously completed by Stantec Geomatics Ltd for the project the UCC drawings were not obtained.

CIMA+ also contacted Allison Hamlin from the City of Ottawa and Abdul Mottalib, City of Ottawa to obtain any site-specific servicing and stormwater management design criteria for the proposed development. The provided comments and criteria relevant to the Site Servicing and Stormwater Management Report are referenced within the appropriate sections of this report.

Rideau Valley Conservation Authority (RVCA)

The subject site falls under the jurisdiction of the Rideau Valley Conservation Authority (RVCA). As previously mentioned, a functional Servicing and Storm Water Management Report – Phase 1 for ZIBI development was submitted in August 2018 which included the RVCA reviewed and approval. These approved criteria were acknowledged and respected as part of this site plan approval report.

Ministry of the Environment, Conservation and Parks (MECP)

It is expected that the application can be submitted to the MECP, if required, as direct submission from Dream following City's Ottawa review.

2. Water Servicing

2.1 Existing Condition

The current ZIBI development is comprised of watermain networks along Booth Street, Chaudière Private and through the underground parking lot below the Head Street Square Courtyard. These the watermain networks vary between 200mm and 300mm in diameter. Refer to Functional Servicing and Stormwater Management Report by DSEL dated August 2018 for technical information about existing watermain network. Refer also to **Figure 2-1** below for visual representation of existing watermain network.

Figure 2-1 Existing Watermain Network

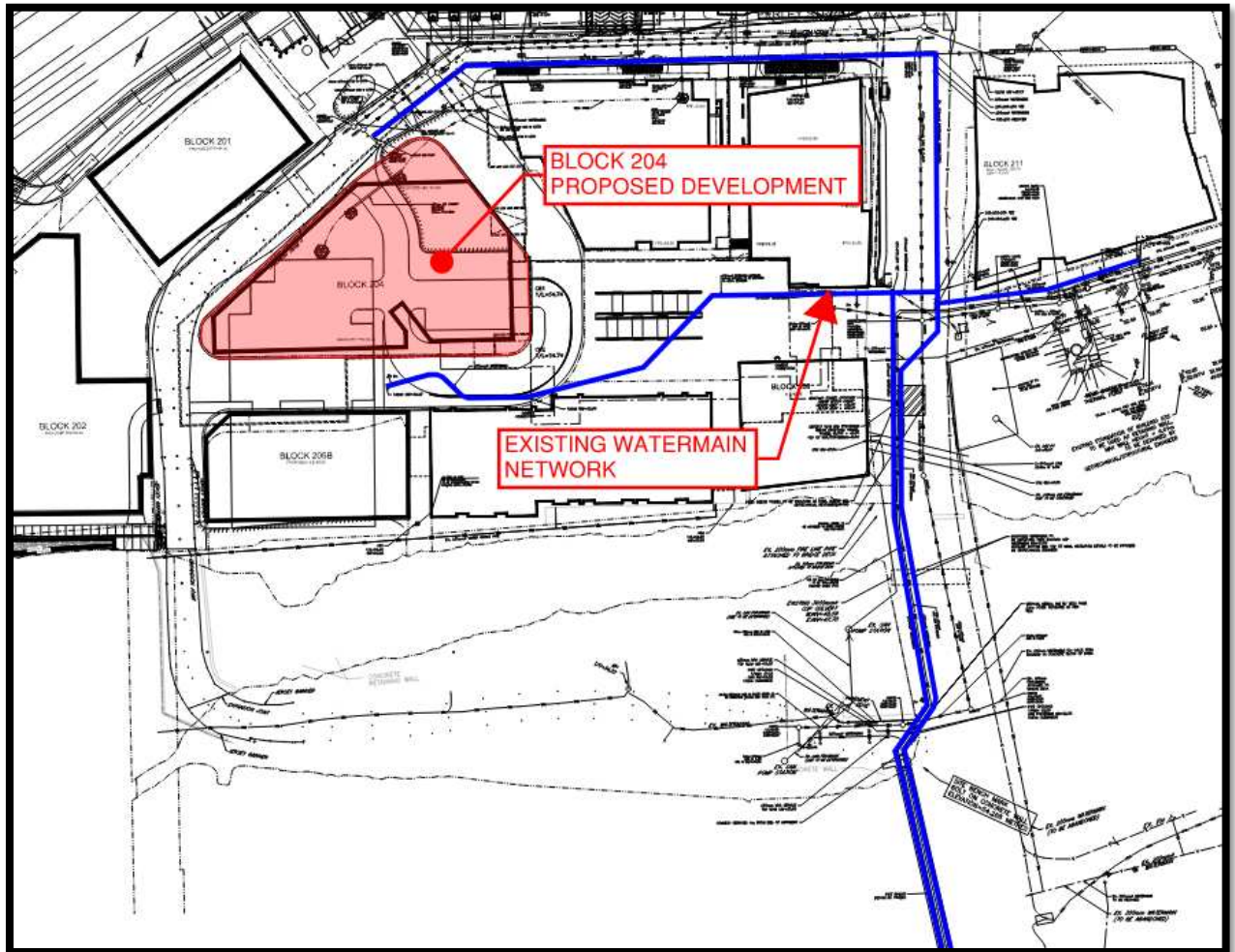

2.2 Water Supply Design Criteria

The design criteria for determining the water demand requirements for the proposed development follow the parameters outlined in the Ottawa Design Guidelines – Water Distribution (2010) and associated technical bulletins, as well as the MOE Design Guidelines for Drinking-Water Systems (2008). Namely, the following parameters have been used in determining the water demands:

Table 2-1: Water Supply Design Criteria

Design Criteria	Residential / Commercial Areas
Average Day Demand for Residential	350 L/capita/day
Maximum Daily Demand for Residential	3.2 × average daily demand
Maximum (Peak) Hour Demand for Residential	4.9 × average daily demand
Average Day Demand Retail	2.5 L/m ² /day
Average Day Demand Amenity	2.5 L/m ² /day
Maximum Daily Demand for Retail and Amenity	1.5 x average daily demand
Maximum (Peak) Hour Demand	1.8 x Maximum Daily Demand
Desired Operating Pressure under Normal Operating Conditions	50 to 70 psi
Minimum Operating Pressure under Normal Operating Conditions	40 psi
Maximum Operating Pressure under Normal Operating Conditions	80 psi
Minimum Operating Pressure under Maximum Daily Demand + Fire Flow	20 psi

In addition to those design criteria identified in **Table 2-1**, the following comments and criteria must be considered in the water supply servicing strategy in accordance with City Guidelines:

- + The subject site is located within the 1W pressure zone;
- + Residential buildings with a basic day demand greater than 50 m³/day (0.57 L/s) are required to be connected to a minimum of two (2) water services separated by an isolation valve to avoid a vulnerable service area;
- + Fire flow demand requirements shall be based on the Fire Underwriters Survey (FUS) Water Supply for Public Fire Protection 1999 and Technical Bulletin ISTB-2018-02;
- + Exposure separation distances shall be defined on a figure to support the FUS calculation and required fire flow (RFF);
- + Hydrant capacity shall be assessed if relying on any public hydrants to provide fire protection, particularly if high design fire flows are being proposed, to demonstrate the Required Fire Flow (RFF) can be achieved. Identification of which hydrants are being considered to meet the RFF on a fire hydrant coverage figure is required as part of the boundary conditions request.

2.3 Proposed Water Supply Servicing and Calculations

Water Demands

The water supply demands for the proposed development are presented in **Table 2-2** below. The demands were developed utilizing the development statistics provided by Neuf Architects Inc. and those design criteria identified in *Section 2.1*. Refer to **Appendix B** for detailed calculations.

Table 2-2: Water Demands Block 204

Demand Type	Average Daily Demand (L/s)	Maximum Daily Demand (L/s)	Maximum (Peak) Hour Demand (L/s)
Residential	1.58	5.06	7.74
Retail & Amenity	0.09	0.13	0.23
Total	1.67	5.18	7.97

Given the basic day demand is more than 50 m³/day (0.57 L/s), two connection is required.

The Water demands for the entire ZIBI site have been updated and are presented in **Table 2-3** below. Flows from existing building came from previous servicing reports. Refer to **Appendix B** for detailed calculations.

Table 2-3: Water Demands Block 204, 211, 206, 207, 205A, 208, EO

Demand Type	Average Daily Demand (L/s)	Maximum Daily Demand (L/s)	Maximum (Peak) Hour Demand (L/s)
Total	5.77	14.11	24.94

Proposed Watermain Network Extension

The existing 300mm watermain along Chaudière Island will be extended around Block 204 and connect to the existing watermain stub south of the site. This will create a loop and increase service level and redundancy within the ZIBI watermain network. The proposed design is as per the approved Master Servicing Study (MSS). The proposed watermain extension will have an additional two fire hydrants and will have service connection stubs for the future development of Block 201, 202 and 205B. Each building will require two separate water connection separated by a valve. A portion of the watermain network will be located inside the underground parking garage. Detailed design by the mechanical consultant will be provided upon completion.

Proposed Service Connection

The proposed connection point for Block 204 will connect to the 300mm Watermain along Chaudière Private. The building will have two 150mm service connection separated by a valve for redundancy purposes.

Required Fire Flow (RFF)

The required fire flow for the site was developed using the Fire Underwriters Survey (FUS) Water Supply for Public Fire Protection 1999 and Technical Bulletin ISTB-2018-02. It was determined that an RFF of **21,000 L/min (350 L/s)** would be required to provide adequate protection.

It was assumed that multiple municipal hydrants would be required to meet the fire flow requirements and a fire hydrant coverage figure was prepared in support of the boundary conditions request from the City.

Refer to **Appendix B** for detailed calculations, including supporting figures for exposure distances and hydrant coverage.

Municipal Boundary Conditions

Using the proposed demands, required fire flow, and supporting figures the City provided boundary conditions for hydraulic analysis for current conditions, based on computer model simulation. The boundary conditions are as follows:

Table 2-4: Watermain Boundary Conditions

Hydraulic Condition (HGL = Hydraulic Grade Line)	Boundary Condition (Connection 1) (Head) (m)	Boundary Condition (Connection 2) (Head) (m)
	Booth Street 305 mm diameter	Booth Street 203 mm diameter
Minimum HGL	107.7	107.7
Maximum HGL	115.7	115.7
Maximum Day + Fire Flow	102.2	98.1

Hydraulic Analysis – Water Supply Adequacy

Since the water and fire flow demands were inferior to the approved master servicing study, no further hydraulic analysis was performed. Refer to table 2-5 (Demand from Master Servicing Study) and table 2-6 (Proposed Current Demand) for comparison.

Table 2-5 WATER DEMANDS FROM MASTER SERVICING STUDY

Water Demand – Proposed Site Conditions					
Design Parameter	Anticipated Demand (L/min)	Boundary Condition ¹ (m H ₂ O / kPa)		Boundary Condition ¹ (m H ₂ O / kPa)	
		Connection @ Booth Street		Connection @ Wellington Street	
Average Daily Demand	858.9	61.7	605.3	58.6	574.9
Max Day + Fire Flow	1754.6 + 22,000 = 23,754.6	47.0	461.1	51.5	505.2
Peak Hour	3624.5	54.8	536.6	51.6	506.2
1) Boundary conditions supplied by the City of Ottawa for demands as indicated in correspondence. Assumed ground elevation @ Booth Street 53.4m , @ Wellington Street 56.5m , See Appendix B .					

Table 2-6: PROPOSED WATER DEMANDS

Demand Type	Average Daily Demand (L/min)	Maximum Daily Demand + Fire Flow (L/min)	Maximum (Peak) Hour Demand (L/min)
Total	346.2	21,847.34	1497.40

As demonstrated above, the proposed water demand is far below the approved water demand that was identified in the master servicing report.

The approved master servicing study had identified that the recommended pressures exceeded the 80psi for the average daily demand. Since the proposed water demand is below the approved demand a pressure reducing valves will be required for the proposed development.

Hydrant Analysis

The proposed Block 204 development is surrounded by two new fire hydrant and 2 existing hydrants. Hydrants #5, #8 and #9 will have a max fire flow of 5700L/min. Hydrants #6 will have the rest of the fire flow with a capacity of 3900L/min. Refer to Appendix B for proposed and existing hydrants.

2.4 Water Supply Summary and Conclusions

The water supply design for the proposed development follows the parameters outlined in the Ottawa Design Guidelines – Water Distribution (2010) as amended by all applicable technical bulletins, as well as the MOE Design Guidelines for Drinking-Water Systems (2008).

There is adequate flow and pressure in the water distribution system to meet the required water demands for the proposed development. Pressure reducing valves will be required for the proposed development.

Water Data Card for service connection is to be completed and submitted once design has been finalized and in preparation to Commence Work Notification and Water Permit Application.

3. Sanitary Servicing

3.1 Existing Conditions

The current site is comprised of a sanitary network that extends from Chaudière Private, Booth Street and Zaida Eddy Street. The sanitary network is comprised of 250-300mm diameter sewer. See **Figure 3-1** for extent of existing network. The sanitary network currently is discharging into a temporary pumping station within the footprint of the existing building 535 to service the first phase of the ZIBI development. As per the report prepared by Hatch dated November 2018, the current station has a max wet weather peak flow capacity of 13 L/s.

The Technical Memorandum for Block 206 prepared by DSEL dated March 2021, stated that the new development of Block 206 exceeded 80% of the temporary pump capacity and that the new permanent pumping station needed to be built before the next block development. The design of the permanent pumping station is currently going through Site Plan application. Refer to ZIBI Pumping Station Preliminary Design Report by Hatch in **Appendix C**.

Figure 3-1 Existing Sanitary Network

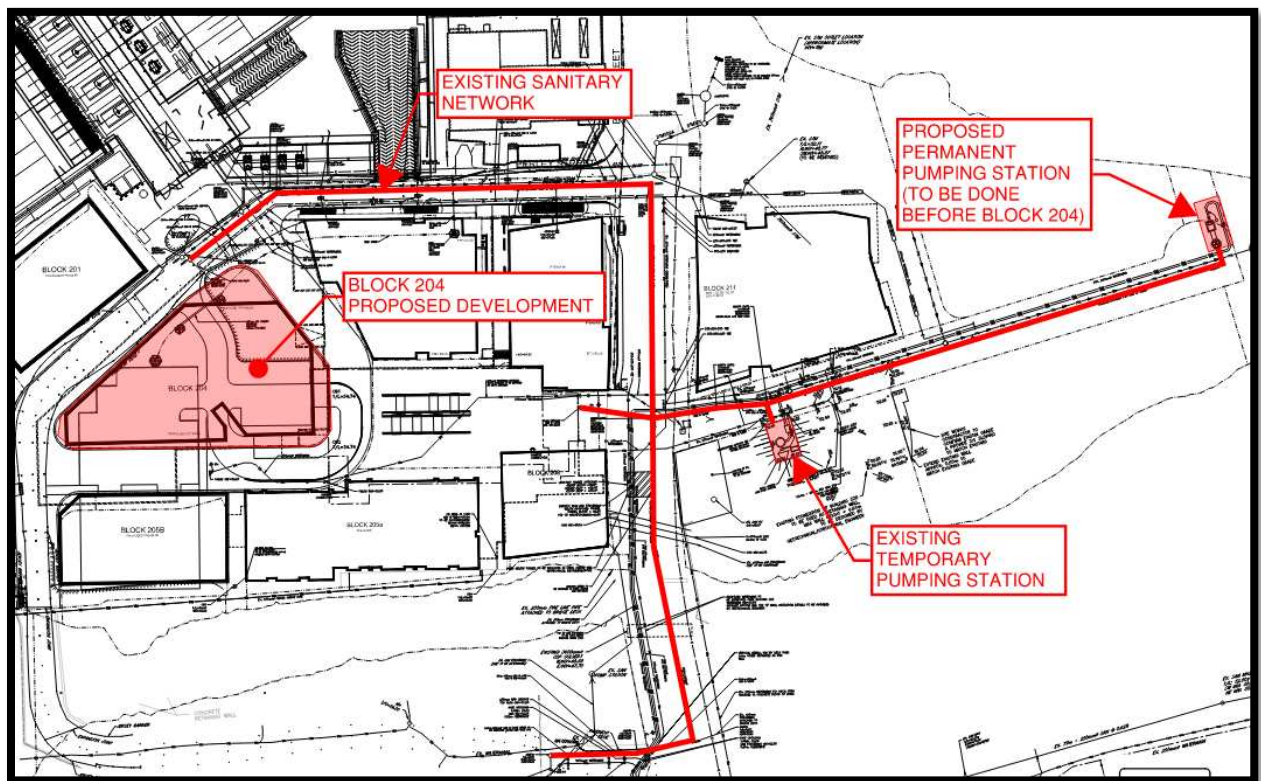

3.2 Sanitary Servicing Design Criteria

The design criteria for determining the sanitary peak flow rates for the proposed development follow the parameters outlined in the City of Ottawa Sewer Design Guidelines, 2012 as amended by all applicable Technical Bulletins. Namely, the following parameters have been used in determining the peak sanitary flow rates:

Table 3-1: Sanitary Peak Flow Determination Design Criteria

Design Criterion	Residential and Commercial Areas
Residential Base Flow	280 L/capita/day
Commercial Base Flow	2.8 L/m ² /day
Populations – Studio	1.4 Persons Per Unit
Population – 1 Bedroom	1.4 Persons Per Unit
Population – 2 Bedroom	2.1 Persons Per Unit
Population – 3 Bedroom	2.7 Persons Per Unit
Peaking Factor for Residential	<p>Determined by Harmon Equation</p> $P.F. = 1 + \left[\frac{1}{4 + \left(\frac{P}{1,000}\right)^{\frac{1}{2}}} \right] \times 0.8$ <p>(P = population; P.F. = peaking factor)</p> <p>Maximum P.F. = 4.0</p> <p>Minimum P.F. = 2.0</p>
Peaking Factor for Commercial	1.5
Dry Weather Infiltration Rate	0.05 L/s/effective gross hectare (for all areas)
Wet Weather Infiltration	0.28 L/s/effective gross hectare (for all areas)
Total Infiltration Allowance	0.33 L/s/effective gross hectare (for all areas)

3.3 Proposed Sanitary Servicing and Calculations

Proposed Sanitary Network Extension

The proposed Sanitary network extension will be as per the approved Master Servicing Study. A detailed Sanitary Calculation sheet has been developed with all the existing and future flows. Refer to **Appendix C** for detail calculations.

Proposed Sanitary Peak Flows

The estimated peak flows from the proposed development and existing development based on the design criteria listed in **Table 3-1** are outlined in the following Table.

Table 3-2: Block 204 Peak Sanitary Flows

Flow Type	Total Flow Rate (L/s)
Total Estimated Average Flow Rate	1.53
Total Estimate Peak Flow Rate (Exclude extraneous flow)	4.71

Refer to **Appendix C** for detailed calculations.

Table 3-3: Total Peak Sanitary Flows (Block 204, 211, 206, 207, 205A, 208, EO)

Flow Type	Total Flow Rate (L/s)
Total Estimated Average Dry Weather Flow Rate	5.94
Total Estimate Peak Dry Weather Flow Rate	15.00
Total Estimate Peak Wet Weather Flow Rate	15.84

Refer to **Appendix C** for detailed calculations.

Block 204 Sanitary Service Connections

Block 204 sanitary servicing will be connected to the new extended 250mm sanitary network by gravity. Connections shall be 200 mm PVC DR26 at a gradient of 2%.

3.4 Sanitary Servicing Summary and Conclusions

The sanitary servicing design for the proposed development conforms to the requirements of the City of Ottawa Sewer Design Guidelines, 2012, as amended by all applicable Technical Bulletins.

New pumping Station will need to be built and operational before the occupancy of Block 204.

Peak wastewater demands are below the ultimate sanitary flow in the approved Master Servicing Study who confirmed that there is adequate residual capacity in the city of Ottawa system to accommodate the proposed wastewater flow.

4. Storm Servicing and Stormwater Management

4.1 Existing Conditions

The western part of ZIBI development is comprised of two existing storm networks. The storm network located in the upper of the development drains most of the north and west parts of the island and discharges to an outlet on the East side of Booth and onto the Ottawa River. The second storm network drains the courtyard between Block 205A, 206 and 204 and is discharge into the underground parking lot where it eventually crosses Booth Street and onto the Ottawa River. See **Figure 4-1** below for existing storm configuration.

Figure 4-1 Existing Storm Network

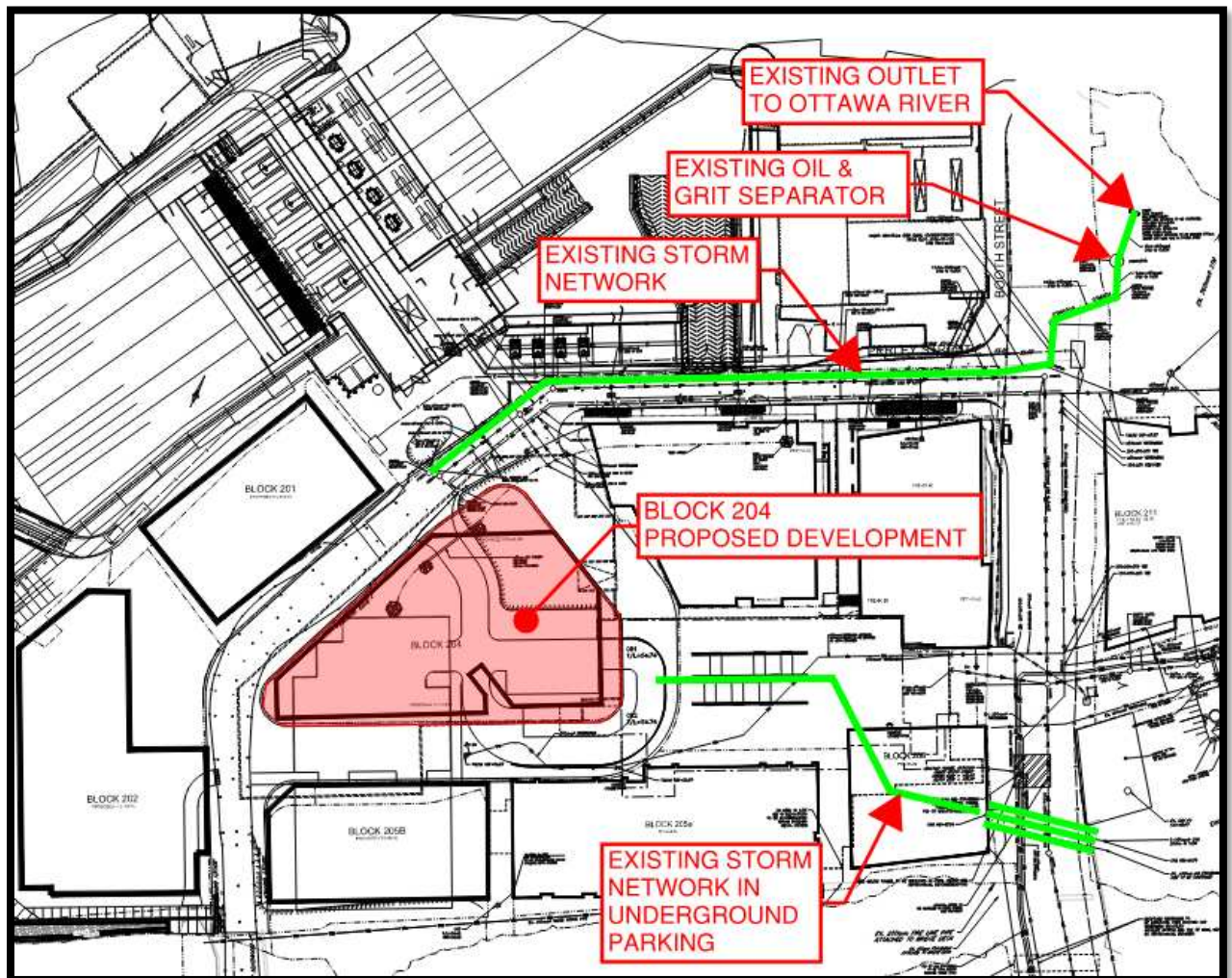

As per the Functional Servicing and Stormwater Management Report by DSEL dated August 2018, the Storm Water Management approach was to design and size the Storm Network for a 5-year storm event and that larger storm events are to use major system flow route. Refer to **Table 4-1** for flows that was calculated in the Phase I servicing report.

Table 4-1: Peak Release Flows – Existing Site

Storm Event	Minor / Major System Flow from Area Fut & 104B (1.059 Ha)			Minor / Major System Flow from Area 104A (0.234 Ha)		
	Minor Flow to HW100 (L/s)	Major Flow to Booth (L/s)	On-Site Max Flow Depth (m)	Minor Flow to Outlet South of 535 (L/s)	Major Flow to Booth (L/s)	On-Site Max Flow Depth (m)
2-Year	183.5	0.28	0.0	15.8	0	0
5-Year	246.6	18.2	0.02	22.3	0	0
100-Year	344.5	121.3	0.10	60.0	0	0

The existing storm network is also comprised of a Stormceptor STC4000 capable of treating 80% TSS removal before discharge to the Ottawa River. The storm network that drains the Courtyard into the underground parking garage is also equipped with an internal mechanical system to treat 80% TSS removal. Refer to Functional Servicing and Stormwater Management Report by DSEL dated August 2018 for technical details of the existing Storm Network.

4.2 Storm Servicing Strategy and Design Criteria

As stated in the Servicing Report by DSEL, quantity control is not required for the site as it will not increase flood risk to the Ottawa River. However, the site plan configuration has been modified since the last stormwater report and a larger area than what was anticipated will be draining to the storm network. Therefore, a full SWM analysis of Western Chaudière Island was completed. Due to the additional surface draining into the existing storm network, roof retention of Block 204 will be implemented in order to not exceed the anticipated peak flow that was identified in the Phase 1 approved report.

As stated in the Servicing Report by DSEL, the site currently has a Stormceptor to ensure 80% TSS removal is achieved as per the set requirement by the Rideau Valley Conservation Authority. Therefore, no additional quality treatment will be required for the proposed development.

4.3 Proposed Storm Servicing and Stormwater Management Design and Calculations

Proposed Storm Network Extension

The proposed storm sewer extension has been sized to capture the 5-year storm event. A Storm Sewer Hydraulic Design sheet using the rational method has been developed to analyze the existing and proposed storm network for the 2, 5 and 100-year storm event. Refer to **Appendix D** for detail calculations.

Proposed Flow Rates and Stormwater Quantity Control

To calculate the peak flow rate, an evaluation of the runoff coefficient was done. The site is comprised of landscape surface, interlock pavers and hard surfaces such as roof and pavement. Refer to **Table 4-2** for the values that were used. The City of Ottawa Sewer Design Guideline does not have an attributed value for interlock pavers and therefore the value of 0.75 was used for from the MTO Drainage Management Manual (1997). Refer to **Appendix D** for table. For the 100-year Storm, the runoff coefficient has been increased by 25% as per City of Ottawa Guideline.

Table 4-2: Runoff Coefficient

Type of surface	Runoff Coefficient
Landscape	0.2
Interlock Pavers	0.75
Hard surface	0.9

For the hydraulic analysis of the storm network, a time of concentration of 10 minutes was used for the beginning of the network. The Block 204 will be doing water retention and will have a release rate of 21.13L/s. The flow restriction on the roof will result in 47m³ of water retention. Around 30% of the roof surface will be developed as green surface and has been considered in the calculations. Below is a table that summarized the peak flow for different storm event and compares the anticipated flow from the Phase I servicing report.

Table 4-2: Post-development Flow Rate

	(Existing)	(Proposed)
Rain event	Phase I anticipated Flow to HW 100 (1.059ha) (L/s)	From STM-111 to HW 100 (1.27ha) (L/s)
2-year	183.78	176.56
5-year	264.8	234.09
100-year	465.8	457.48

The main network draining to HW 100 (Outlet structure) has a greater area than what was anticipated during the design of Phase I. However, due to the retention done by Block 204 and using a runoff coefficient of 0.75 for interlock pavers, we obtain a peak flow that is lower than what was anticipated. (Refer to table 4-2)

The Courtyard area (Catchment A10) that drains into the underground parking lot has been reduced in size from the previous Phase 1 development. Phase 1 had anticipated an area of 0.234ha draining into the underground parking lot. The proposed development will only have 0.196ha draining into the underground parking lot system. Since the area has significantly been reduced, it is safe to say that the flow going into the underground network will be reduced and will not exceed the flows that were calculated in the Phase 1 approved report.

Stormwater Service Connections

The Block 204 and future Blocks will have a storm service of 250mm diameter with a minimum slope of 1%. The service line will be used to convey the roof flow and foundation drain.

Stormwater Quality Control

As mentioned in section 4.1, the site is currently equipped with a Stormceptor to treat 80% TSS removal as required by the Rideau Valley Conservation Authority.

4.4 Storm Servicing and Stormwater Management Summary and Conclusions

The storm servicing design for the proposed development conforms to the requirements of the City of Ottawa Sewer Design Guidelines, 2012, as amended by all applicable Technical Bulletins.

The peak flow rate for the 100-year storm is below the anticipated flow that was calculated during the Phase I report. Therefore, no additional storm analysis was done.

Roof Flow Control Declaration will be provided upon completion of the Mechanical and Structural design.

5. Conclusion

The purpose of this assessment is to confirm that the proposed development can be adequately serviced using the existing municipal infrastructure (water, sanitary, and storm) surrounding the site. This assessment shall be used in support of a Site Plan Control Application to allow for the construction of Block 204.

The important information and findings as a result of this assessment are as follows:

- + The anticipated water demands for the ZIBI site are **346.49 L/min** (average day), **21,847.34 L/min** (max day + fire flow), and **1497.4 L/min** (peak hour). Based on the boundary conditions provided by the City an additional private hydrant will be required on site to provide adequate fire flow. There is adequate flow and pressure in the water distribution system to meet the required potable water demands for the proposed development.
- + The estimated sanitary flow for the proposed Block 204 development is **1.56 L/s** (average flow rate) and **4.74 L/s** (peak flow rate);
- + The estimated sanitary flow for the ZIBI site is **5.96 L/s** (average flow rate), **15.02 L/s** (peak dry weather), and **15.86 L/s** (peak wet weather). The new permanent pumping station designed by Hatch will need to be in operation before the Block 204 occupancy. The City of Ottawa has indicated that they can accept the anticipated sanitary flow for full built-up of the ZIBI development in the Master Servicing Study (MSS);

- + Storm Peak Flow to HW-100 outlet for the 100-year event is lower than what was anticipated in the Phase I servicing report. The area of the Courtyard has been decreased from the Phase 1 report and therefore will have a lower flow than what was anticipated;
- + The site is currently equipped with an Oil Grit Separator and therefore no additional quality treatment was proposed for the development;
- + Roof Flow Control Declaration will be provided upon completion of the Mechanical and Structural design.

We trust this Site Servicing and Stormwater Management Report is to your satisfaction. If you have any questions regarding this report, please do not hesitate to contact any of the signatories.

A

Appendix A Correspondence



Julien Sauvé

From: Hamlin, Allison <Allison.Hamlin@ottawa.ca>
Sent: Wednesday, January 19, 2022 9:32 AM
To: Paul Cope; Darrin Rankine; Justin Robitaille
Cc: Mottalib, Abdul; Paudel, Neeti; Wang, Randolph; Patel, Parthvi
Subject: Pre-application Consultation Follow-up Email - ZIBI Block 204, 317 Miwate Private

--EXTERNAL--

Hello,

Thank you for meeting with us to discuss the fourth phase of development at Zibi. Your presentation was very helpful.

Please refer to the below and attached notes regarding the Pre-Application Consultation Meeting held on January 6, 2022, for the 22-storey, mixed-use, high-rise development at Zibi (Block 204, 315 private, Miwate Private, Chaudière Island).

Below are staff's preliminary comments based on the information presented at the time of the pre-consultation meeting:

Planning

- A site plan application (Complex) will be required.
- Zoning: MD5[2172] S332; OP(2003): Central Area and Central Area Secondary Plan, Mixed Use on Schedule Q; New OP: Ottawa River Islands Special District within the Downtown Core Transect.
- Please provide details of if/how lands will be severed and how the woonerf will be added to the plan of condo in your cover letter.
- Please provide a legal description and a legal survey of the subject lands with your application. A topographical sketch will not be sufficient.

Transportation

- TIA requirements - An addendum with trips, MMLoS and TDM for this site is accepted. It is recommended that the development provide as many TDM measures to enable and encourage travel by active modes.
- Ensure continuous, safe, and accessible pedestrian connections is provided from the site to the transit service on Booth Street. Recommend providing a close/ direct active mode connection through Block 204, 206 and 207 to Booth Street.
- Site triangles at the following locations on the final plan will be required:
 - Local Road to Local Road: 3 metre x 3 metres
- On site plan:

- Show all details of the roads abutting the site up to and including the opposite curb; include such items as pavement markings, accesses and/or sidewalks.
- Turning templates will be required for all accesses showing the largest vehicle to access the site; required for internal movements and at all access (entering and exiting and going in both directions).
- Show all curb radii measurements; ensure that all curb radii are reduced as much as possible
- Show lane/aisle widths.
- Sidewalk is to be continuous across access as per City Specification 7.1.
- AODA legislation applies for all areas accessible to the public. Consider using Accessibility Design Standards

Urban Design

- A Design Brief is required as part of the submission. The Terms of Reference is attached for convenience.
- Please consider both the Design Framework and Development Principles and the Heritage Interpretive Plan within the analysis.
- The site is within a Design Priority Area and formal review by the City's Urban Design Review Panel is required. The applicant can also benefit from informal review by the UDRP prior to submitting the application. Please reach out to the City's UDRP coordinator at udrp@ottawa.ca for scheduling details. Please note the UDRP is currently under high pressure with respect to project scheduling. Priority is given to projects at the stage of formal review.
- With respect to the design presented at the pre-consultation meeting, the programming and general site organization appears to have followed the approved master plan for the island. The detailed analysis and architectural aspirations presented by the architect are also appreciated. However, certain aspects of the design, particularly the positioning, shape, and the massing articulation of the tower are not most convincing.
 - Locating the tower to the northmost part of the site, while creating opportunities for a south-facing roof top amenity space, crowds the north shore of the island with a wall of towers. Do the benefits of this design strategy outweigh the shortcomings? Have the overall microclimate conditions of the site and the surrounding area been fully examined?
 - The generally rectangular shape of the tower appears to be quite arbitrary for the site and its location and does not respond to geometry of the site and the surrounding contextual elements effectively.
- Moving forward, it is important to continue to explore site plan and massing options taking into consideration the views of the island from the various vantage points as well as the overall optimal microclimate conditions of the site and the island. It is recommended as a best practice that a shadow study and a desk top wind study be prepared for each massing options explored to facilitate decision making.

Infrastructure

Capacity issues for sewers

- Please find the Servicing Report Template & Study Guidelines” in the attachment and prepare the servicing study accordingly. For capacity issue, please see section 3.2.1 page 3-3 and follow this section. A completed checklist with corresponding references from the servicing study is mandatory for the completeness of the study. Please add a completed checklist in the report.
 - Sanitary: as per approved master plan
 - Storm: as per approved master plan
 - Water: as per approved master plan
 - Sewage Pumping Station: Block 204 triggers Sewage Pumping Station. Sewage pumping station approval is required for this site as per the master plan agreement.

Required information for Water boundary conditions (not required if you're using existing service)

- Boundary conditions are required to confirm that the require fire flows can be achieved as well as availability of the domestic water pressure on the city street in front of the development. Please use Table 3-3 of the MOE Design Guidelines for Drinking-Water System to determine Maximum Day and Maximum Hour peaking factors for 0 to 500 persons and use Table 4.2 of the Ottawa Design Guidelines, Water Distribution for 501 to 3,000 persons.
 1. Location of Service
 2. A sketch of the proposed water service to the city watermain
 3. Street Number & Name
 4. Type of development and units
 5. Amount of fire flow required ___ l/s (Calculation as per the FUS Method).
 6. Average daily demand: -l/s
 7. Maximum daily demand: -l/s
 8. Maximum hourly daily demand: -l/s
- Please note proposed development will require 2 separate service connections from the city watermains if the basic day demand is greater than 50m³/day to avoid the creation of a vulnerable service area. Two water meters will be required for two service connections and the service connections will have to be looped.

Underground and above ground building footprints

- All underground and above ground building footprints and permanent walls need to be shown on the plan to confirm that any permanent structure does not extend either above or below into the existing property lines, sight triangles and/or future road widening protection limits.

Grade limitations for underground ramps

- Underground ramps should be limited to a 12% grade and must contain a subsurface melting device when exceeding 6%. If the ramp's break over slope exceeds 8%, a vertical-curve transition or a transition slope of half the ramp slope should be used.

Stormwater management criteria

- Quantity and quality control of the storm flow will be implemented as per master plan.

Monitoring MHs

- Onsite Monitoring MHs are required for sewers (sanitary and storm) if there will be commercial component with the residential development.

Studies required for Site Plan application

- Serviceability Study
- Erosion and sediment Control Plan, it can be combined with grading plan
- Stormwater Management Report
- Geotechnical Study
- Phase 2 Noise Control Detailed Study
- ESA-Phase 1 Study and Phase 2: Updated Phase II is required to ensure further contamination has not occurred and a description of the remediation process with available test results for our review.
- Filling of RSC.
- Wind Analysis
- Sewage Pumping Station

MOECC SWM Requirement:

- It will be indicated in the first review comments whether an ECA is required for that submission.

Relevant information

- Servicing & site works shall be in accordance with the following documents:
 - Ottawa Sewer Design Guidelines (2012)
 - Ottawa Design Guidelines – Water Distribution (2010)
 - Geotechnical Investigation and Reporting Guidelines for Development Applications in the City of Ottawa (2007)
 - City of Ottawa Slope Stability Guidelines for Development Applications (2004)
 - City of Ottawa Environmental Noise Control Guidelines (2006)
 - City of Ottawa Park and Pathway Development Manual (2012)
 - City of Ottawa Accessibility Design Standards (2012)
 - Ottawa Standard Tender Documents (2015)
 - Ontario Provincial Standards for Roads & Public Works (2015)
- Record drawings and utility plans can be purchased from the City (Contact the City's Information Centre by email at InformationCentre@ottawa.ca or by phone at (613) 580-2424 x.44455).

City Surveyor

- The determination of property boundaries, minimum setbacks and other regulatory constraints are a critical component of development. An Ontario Land Surveyor (O.L.S.) needs to be consulted at the outset of a project to ensure properties are properly defined and can be used as the geospatial framework for the development.

- o Topographic details may also be required for a project and should be either carried out by the O.L.S. that has provided the Legal Survey or done in consultation with the O.L.S. to ensure that the project is integrated to the appropriate control network.

Questions regarding the above requirements can be directed to the City's Surveyor, Bill Harper, at Bill.Harper@ottawa.ca

Community Representative Comments

- Please see attached minutes

Other

- o Plans are to be standard A1 size (594 mm x 841 mm) sheets, utilizing an appropriate Metric scale (1:200, 1:250, 1:300, 1:400 or 1:500).
- o All PDF submitted documents are to be unlocked and flattened.
- o You are encouraged to contact the Ward Councillor, Councillor Catherine McKenney, about the proposal.

Please refer to the links to [Guide to preparing studies and plans](#) and [fees](#) for further information. Additional information is available related to [building permits, development charges, and the Accessibility Design Standards](#). Be aware that other fees and permits may be required, outside of the development review process. You may obtain background drawings by contacting informationcentre@ottawa.ca.

These pre-application consultation comments are valid for one year. If you submit a development application(s) after this time, you may be required to meet for another pre-consultation meeting and/or the submission requirements may change. You are as well encouraged to contact us for a follow-up meeting if the plan/concept will be further refined. Please do not hesitate to contact me if you have any questions.

Regards,

Allison Hamlin, MCIP, RPP

Planner III (A) | *Urbaniste III (A)*

Development Review Central | *Examen des demandes d'aménagement secteur centre*

Planning, Real Estate and Economic Development Department | *Services de la planification, des biens immobiliers et du développement économique*

City of Ottawa | *Ville d'Ottawa*

110 Laurier Avenue West. Ottawa, ON | 110, avenue. Laurier Ouest. Ottawa (Ontario) K1P 1J1

613.580.2424 ext./ poste 25477

ottawa.ca/planning / ottawa.ca/urbanisme

,

This e-mail originates from the City of Ottawa e-mail system. Any distribution, use or copying of this e-mail or the information it contains by other than the intended recipient(s) is unauthorized. Thank you.

Le présent courriel a été expédié par le système de courriels de la Ville d'Ottawa. Toute distribution, utilisation ou reproduction du courriel ou des renseignements qui s'y trouvent par une personne autre que son destinataire prévu est interdite. Je vous remercie de votre collaboration.

From: James Pye <jpye@rjc.ca>
Sent: Monday, August 15, 2022 11:58 AM
To: André Chaumont
Cc: Taryn Glancy; Julien Sauvé; Ken Turcotte
Subject: RE: A000931 - ZIBI - Block 204 - Underground Parking - Structural Confirmation

Follow Up Flag: Follow up
Flag Status: Flagged

EXTERNAL EMAIL

Hi Andre,

Apologies for the delayed response, I've been on vacation the past week.

I can confirm that we will be designing the parking garage roof for heavy truck loading per OBC requirements.

Thanks,

James Pye, MEng, P.Eng.
Associate/Regional Manager
direct (613) 714-7003 | **mobile** (613) 355-4925 | jpye@rjc.ca | rjc.ca

Read Jones Christoffersen Ltd.
Engineers

From: André Chaumont <Andre.Chaumont@cima.ca>
Sent: August 9, 2022 4:33 PM
To: James Pye <jpye@rjc.ca>
Cc: Taryn Glancy <TGlancy@zibi.ca>; Julien Sauvé <Julien.Sauve@cima.ca>
Subject: A000931 - ZIBI - Block 204 - Underground Parking - Structural Confirmation

James

As you know, we submitted for siteplan approval to the City for Block 204 located on ZIBI site, Ottawa, Ontario. One of the comment received relates to the underground parking garage – Comment 39 to follow:

39. Please confirm that any portion of the roof top of the underground parking not have heavy vehicular access such as fire truck.

Yesterday, we met with the city to review all comments. We confirmed that there will be heavy vehicle which will circulate over the underground parking garage since it extends beyond the building 204

perimeter. Based on our response, the City ask us to provide a confirmation that the underground parking garage will be designed to allow heavy truck to circulate.

Could you please provide a confirmation, via email that acknowledge this requirement.

Should you have questions, please call

Regards

ANDRÉ CHAUMONT, ing / P.Eng
Associé / Directeur principal
Partner / Senior Director

T 819-663-9294 poste 6324 **C** 613-761-0558 **F** 819-663-0084
201-420, boul. Maloney Est, Gatineau QC J8P 1E7 CANADA 110-240 Catherine Street, Ottawa, ON
K2P 2G8 CANADA



L'humain au centre
de l'ingénierie



Devez-vous vraiment imprimer ce courriel? Pensons à l'environnement!
Do you really need to print this email? Let's protect the environment!

AVERTISSEMENT CONCERNANT LA CONFIDENTIALITÉ Ce message est confidentiel. S'il ne vous est pas destiné, veuillez en informer l'émetteur immédiatement et le détruire intégralement.
CONFIDENTIALITY WARNING This email is confidential. If you are not the intended recipient, please notify the sender immediately and delete it in its entirety.



Smith + Andersen

1600 Carling Ave Suite 530 Ottawa Ontario K1Z 1G3
613 230 1186 f 613 230 2598 smithandandersen.com

2022-08-29

City of Ottawa

Infrastructure Services and Community Sustainability
110 Laurier Avenue West
Ottawa, ON
K1P 1J1

Attention: City Building Official

**RE: ZIBI BLOCK 204, 315 PRIVÉ MIWÀTE PRIVATE
S+A PROJECT # 22087.000.M.001
SPRINKLER SYSTEM DESIGN**

Dear City Building Official:

This letter is to confirm that the sprinkler system will be designed as a fully supervised system that will be continuously monitored with fire alarm. System shall be designed to NFPA 13 and conform to all applicable NFPA standards.

Yours truly,

SMITH + ANDERSEN

Elaine Guenette B.A.Sc., P.Eng., LEED AP
Principal

22087.000.m.001.I001

C.C. Justin Alarie – Smith + Andersen



B

Appendix B Water Supply Calculations





PROJECT NAME: ZIBI Block 204
CIMA+ PROJECT NUMBER: A000931
CLIENT: DREAM
PROJECT STATUS: Site Plan Application

WATER CONSUMPTION CALCULATIONS

APPLICABLE DESIGN GUIDELINES:

1. Ottawa Design Guidelines - Water Distribution (2010)
2. City of Ottawa Technical Bulletin ISTB-2018-02, ISDTB-2014-02 and ISD-2010-02
3. MOE Design Guidelines for Drinking-Water Systems

RESIDENTIAL AND COMMERCIAL WATER DEMANDS:

RESIDENTIAL DESIGN CRITERIA:

Residential Average Day Demand: 350 L/c/day
Maximum Day Peaking Factor: 3.2 x Average Daily Demand
Maximum (Peak Hour) Peaking Factor: 4.9 x Average Daily Demand

Per Unit Populations:

Unit Type	Persons Per Unit
Single Family	3.4
Semi-detached	2.7
Duplex	2.3
Townhouse (row)	2.7
Apartments:	
Bachelor	1.4
1 Bedroom	1.4
2 Bedroom	2.1
3 Bedroom	3.1
Average Apt.	1.8

EQUIVALENT POPULATION :

Unit Type	Number of Units	Persons Per Unit	Population
1 Bedroom Apartments	142	1.4	199
2 Bedroom Apartments	74	2.1	155
Studio	26	1.4	36
Total	242		390

RETAIL & AMENITY DESIGN CRITERIA:

Contributing Retail & Amenity Area: 2,964.000 m²
Retail & Amenity Average Day Demand: 2.5 L/m²/d
Maximum Day Peaking Factor: 1.5 x Average Daily Demand
Maximum (Peak Hour) Peaking Factor: 1.8 x Maximum Daily Demand

WATER DEMANDS:

Demand Type	Average Daily Demand (L/s)	Maximum Daily Demand (L/s)	Maximum (Peak) Hour Demand (L/s)
Residential	1.58	5.06	7.74
Retail & Amenity	0.09	0.13	0.23
Total	1.67	5.18	7.97

NOTES:

1. Maximum Day and Maximum Hour residential peaking factors determined using Table 3-3 of the MOE Design Guidelines for Drinking-Water System for 0 to 500 persons.

2. Given basic day demand is more than 50 m³/day (0.57 L/s), two connection is required.

Prepared by: Julien Sauvé, P.Eng.
PEO #100200100

Date: 2022/08/22

Verified by: André Chaumont, P.Eng.
PEO #90409194

Date: 2022/08/22



PROJECT NAME: ZIBI Block 204
CIMA+ PROJECT NUMBER: A000931
CLIENT: DREAM
PROJECT STATUS: Site Plan Application

WATER CONSUMPTION CALCULATIONS

APPLICABLE DESIGN GUIDELINES:

1. Ottawa Design Guidelines - Water Distribution (2010)
2. City of Ottawa Technical Bulletin ISTB-2018-02, ISDTB-2014-02 and ISD-2010-02
3. MOE Design Guidelines for Drinking-Water Systems

WATER DEMANDS:

Phase	Block	Type	Unit Rate		No Units	Avg Day L/min	Max Day L/min	Peak Hour L/min
1	208	Office	75	L/9.3m ² /d	975	5.46	8.19	14.75
1	208	Retail	2.5	L/m ² /d	736	1.28	1.92	3.45
1	208	Restaurant	125	L/seat/d	8	0.69	1.04	1.88
1	205A	Res	474.6	L/unit/d	71	23.4	114.66	173.16
1	205A	Retail	2.5	L/m ² /d	754	1.31	1.96	3.53
3	207	Office	75	L/9.3m ² /d	4544	25.45	38.17	68.71
3	207	Retail	2.5	L/m ² /d	567	0.98	1.48	2.66
3	207	Restaurant	125	L/seat/d	150	13.02	19.53	35.16
4	206	Res	280	L/unit/d	447	86.92	217.29	478.04
4	206	Retail	2.5	L/m ² /d	857	1.49	2.23	4.02
4	206	Amenity	2.5	L/m ² /d	1509	2.62	3.93	7.07
2	211	Office	75	L/9.3m ² /d	14480	81.09	121.64	218.95
2	211	Retail	2.5	L/m ² /d	1082	1.88	2.82	5.07
5	204	Res	350	L/p/d	390.00	94.79	303.33	464.48
5	204	Retail	2.5	L/m ² /d	1216.00	2.11	3.17	5.70
5	204	Amenity	2.5	L/m ² /d	1748.00	3.03	4.55	8.19
1	EO	Office	75	L/p/d	12	0.63	0.94	1.69
					Total	346.16	846.85	1496.51

NOTES:

1. Maximum Day and Maximum Hour residential peaking factors determined using Table 3-3 of the MOE Design Guidelines for Drinking-Water System for 0 to 500 persons.

Prepared by: Julien Sauvé, P.Eng.
PEO #100200100

Date: 2022/08/22

Verified by: André Chaumont, P.Eng.
PEO #90409194

Date: 2022/08/22



PROJECT NAME: ZIBI Block 204

CIMA+ PROJECT NUMBER: A000931

CLIENT: DREAN

PROJECT STATUS: Site Plan Control

FIRE FLOW ASSESSMENT

APPLICABLE DESIGN GUIDELINES:

1. Fire Underwriters Survey (FUS) Water Supply for Public Fire Protection, 1999
2. Ottawa Design Guidelines - Water Distribution (2010) including Appendix H per ISTB-2018-02
3. City of Ottawa Technical Bulletin ISTB-2018-02
4. MOE Design Guidelines for Drinking-Water Systems

STEP A - DETERMINE THE TYPE OF CONSTRUCTION

Type of Construction	Coefficient (C)	Value Selected (C)
Fire-resistive Construction (> 3 hours)	0.6	0.7
Fire-resistive Construction (> 2 hours)	0.7	
Non-combustible Construction	0.8	
Ordinary Construction	1.0	
Wood Frame Construction	1.5	

STEP B - DETERMINE THE FLOOR AREA

Floor/Level	Floor Area Per Level (sq. ft.)	Floor Area Per Level (m2)	Fire Resistive Building	Protected Openings (one hour rating)	Area of Structure Considered (m2)
GFA Level 1:	22,128	2,056	YES	YES	22,128
Mezzanine	7,879	732			183
GFA Level 2:	12,437	1,155			289
GFA Level 3:	12,537	1,165			-
GFA Level 4:	12,537	1,165			-
GFA Level 5:	12,537	1,165			-
GFA Level 6:	11,340	1,054			-
GFA Level 7:	11,340	1,054			-
GFA Level 8:	11,340	1,054			-
GFA Level 9:	7,707	716			-
GFA Level 10:	7,528	699			-
GFA Level 11:	7,528	699			-
GFA Level 12:	7,528	699			-
GFA Level 13:	7,528	699			-
GFA Level 14:	7,528	699			-
GFA Level 15:	7,528	699			-
GFA Level 16:	7,528	699			-
GFA Level 17:	7,528	699			-
GFA Level 18:	7,528	699			-
GFA Level 19:	7,528	699			-
GFA Level 20:	7,528	699			-
GFA Level 21:	7,528	699			-
GFA Level 22:	7,528	699			-
GFA Level Mechanical Penthouse	1,943	181	-		
TOTAL FLOOR AREA (A):	221,589	20,586			22,600



PROJECT NAME: ZIBI Block 204
 CIMA+ PROJECT NUMBER: A000931
 CLIENT: DREAN
 PROJECT STATUS: Site Plan Control

FIRE FLOW ASSESSMENT

STEP C - DETERMINE THE HEIGHT IN STOREYS

Floor/Level	Number of Storeys	Percent of Floor Area Considered
Ground Level:	1	100%
Mezzanine	1	25%
Level 2:	1	25%
Level 3:	1	-
Level 4:	1	-
Level 5:	1	-
Level 6:	1	-
Level 7:	1	-
Level 8:	1	-
Level 9:	1	-
Level 10:	1	-
Level 11:	1	-
Level 12:	1	-
Level 13:	1	-
Level 14:	1	-
Level 15:	1	-
Level 16:	1	-
Level 17:	1	-
Level 18:	1	-
Level 19:	1	-
Level 20:	1	-
Level 21:	1	-
Level 22:	1	-
Mechanical Penthouse	1	-
HEIGHT IN STOREYS:	24	

STEP D - DETERMINE BASE FIRE FLOW (ROUND TO NEAREST 1,000 L/min)

$$F = 220C\sqrt{A}$$

Where:

- F is the required fire flow in L/min
- C is the coefficient related to the type of construction, and;
- A is the total floor area of the building in m²

Coefficient Related to Type of Construction (C) = 0.7
 Floor Area Considered (A) = 22,600 m²

REQUIRED (BASE) FIRE FLOW (F) = 23000 L/min (Rounded to Nearest 1,000 L/min)

STEP E - DETERMINE THE INCREASE OR DECREASE FOR OCCUPANCY AND APPLY TO STEP D (STEP D x STEP E, DO NOT ROUND)

Occupancy Class	Occupancy Factor	Value Selected (C)
Non-combustible	0.75	0.85
Limited combustible	0.85	
Combustible	1.00	
Free burning	1.15	
Rapid burning	1.25	

REQUIRED (BASE) FIRE FLOW (F) = 19550 L/min (Not rounded)



PROJECT NAME: ZIBI Block 204
 CIMA+ PROJECT NUMBER: A000931
 CLIENT: DREAN
 PROJECT STATUS: Site Plan Control

FIRE FLOW ASSESSMENT

STEP F - DETERMINE THE DECREASE, IF ANY, FOR AUTOMATIC SPRINKLER PROTECTION AND APPLY TO VALUE IN STEP D ABOVE (DO NOT ROUND)

Sprinkler System Design	Sprinkler Design Charge	Value Selected (C)	Total Charge
Automatic sprinkler system conforming to NFPA standards	-30%	Yes	-30%
Standard water supply	-10%	Yes	-10%
Fully supervised system	-10%	Yes	-10%
TOTAL CHARGE FOR SPRINKLER SYSTEM			-50%

DECREASE FOR SPRINKLER PROTECTION = **-11500** L/min (Not rounded)

STEP G - DETERMINE THE TOTAL INCREASE FOR EXPOSURES AND APPLY TO VALUE IN STEP D ABOVE (DO NOT ROUND)

Façade	Separation Distance (m)	Length-height Factor of Exposed Wall (m-storeys)	Assumed Construction of Exposed Wall of Adjacent Structure	Total Charge
North Façade	16.0	1222	Fire Resistive or Ordinary with Unprotected Openings	15%
East Façade	16.0	256	Fire Resistive or Ordinary with Unprotected Openings	15%
South Façade	17.0	1420	Fire Resistive or Ordinary with Unprotected Openings	15%
West Façade	17.0	56	Fire Resistive or Ordinary with Unprotected Openings	11%
TOTAL CHARGE FOR EXPOSURES				56%

INCREASE FOR EXPOSURES = **12880** L/min (Not rounded)

STEP H - DETERMINE FIRE FLOW INCLUDING ALL INCREASES AND REDUCTIONS ((STEP E + STEP F + STEP G, ROUND TO NEAREST 1,000 L/min)

TOTAL REQUIRED FIRE FLOW (RFF) = **21000** L/min (Rounded to Nearest 1,000 L/min)
350.00 L/s
5548 USGPM



PROJECT NAME: ZIBI Block 204
CIMA+ PROJECT NUMBER: A000931
CLIENT: DREAN
PROJECT STATUS: Site Plan Control

FIRE FLOW ASSESSMENT

NOTES/COMMENTS:

STEP A - DETERMINE THE TYPE OF CONSTRUCTION

1. Building is made of typical Reinforced Concrete and has a fire rating of two hours. Extrapolation was used to determine the coefficient

STEP B - DETERMINE THE FLOOR AREA

1. Assumed vertical openings and exterior vertical communications are properly protected (one hour rating), thus only the area of the largest floor plus 25% of each of the two immediately adjoining floors accounted for per Fire Underwriters Survey (FUS) Water Supply for Public Fire Protection, 1999

STEP C - DETERMINE THE HEIGHT IN STOREYS

1. One levels of underground parking not considered as they are at least 50% below grade (note F of Fire Underwriters Survey (FUS) Water Supply for Public Fire Protection, 1999)

STEP D - DETERMINE BASE FIRE FLOW (ROUND TO NEAREST 1,000 L/min)

1. No notes or comments.

STEP E - DETERMINE THE INCREASE OR DECREASE FOR OCCUPANCY AND APPLY TO STEP D (STEP D x STEP E, DO NOT ROUND)

1. Occupancy selected will fall under C-2 occupancy type as per Neuf Architect.

STEP F - DETERMINE THE DECREASE, IF ANY, FOR AUTOMATIC SPRINKLER PROTECTION AND APPLY TO VALUE IN STEP D ABOVE (DO NOT ROUND)

1. Sprinkler system will be fully supervised.

STEP G - DETERMINE THE TOTAL INCREASE FOR EXPOSURES AND APPLY TO VALUE IN STEP D ABOVE (DO NOT ROUND)

1. Refer to sketch in Appendix for distance used in calculation.

STEP H - DETERMINE FIRE FLOW INCLUDING ALL INCREASES AND REDUCTIONS ((STEP E + STEP F + STEP G, ROUND TO NEAREST 1,000 L/min)

1. No notes or comments.

Prepared by: Julien Sauvé, P.Eng.
PEO# 100173201

Date: 2022/04/05

Verified by: André Chaumont, P.Eng.
PEO #90409194

Date: 2022/04/05

TITLEBLOCK 24383 VERT ENG 3.0
 PRINT DATE: 2022/04/14 / PAPER SIZE: A3
 PATH: Z:\Cma-C\10\Dr\Projects\A000931_Zibi\Block 7_Ottawa\400_Drafting\400_Civil\Figures for Fire Protection.dwg / LAYOUT: Separation Distance

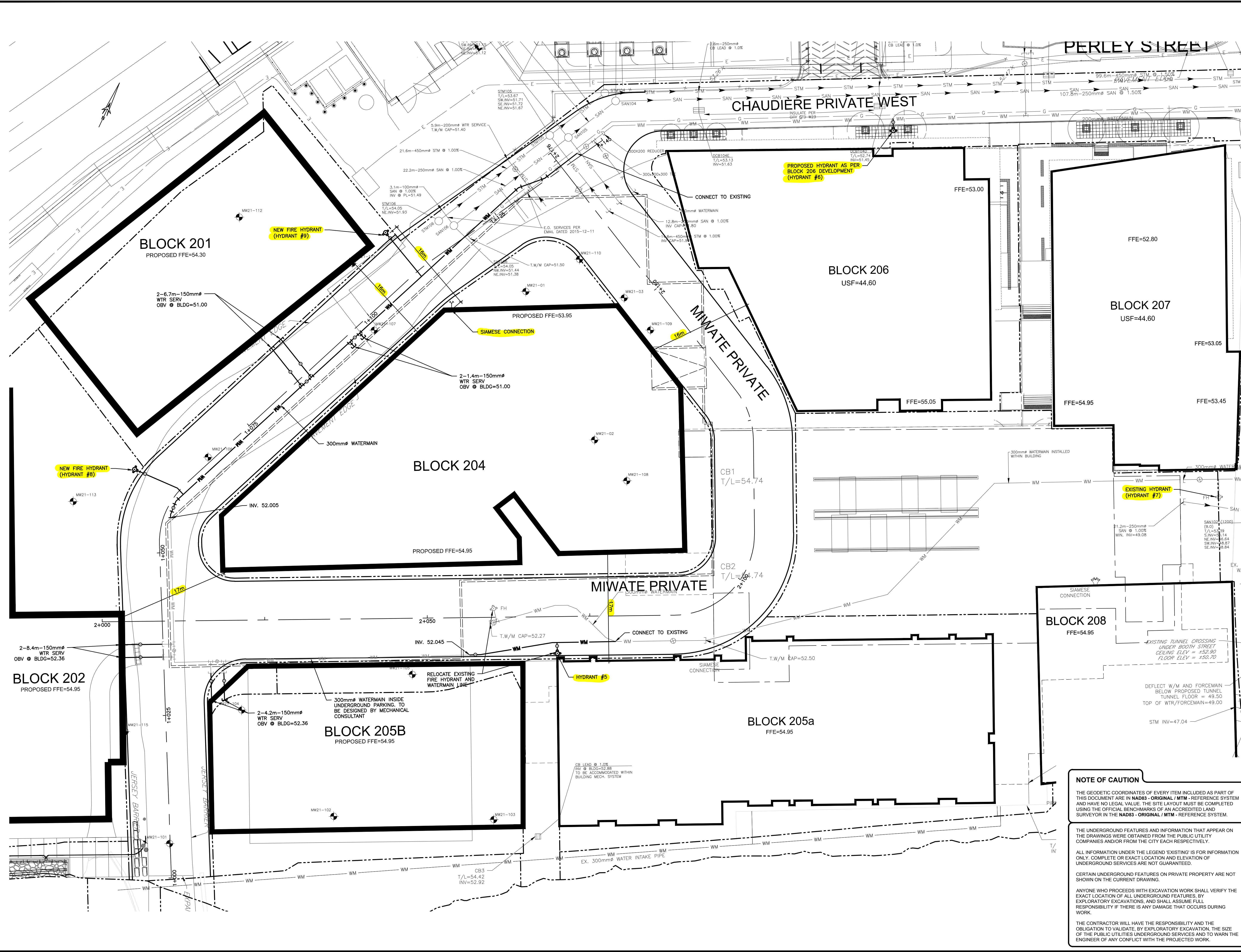

EXISTING		PROPOSED	
WM	WATERMAIN	WM	WATERMAIN
SAN	SANITARY SEWER	SAN	SANITARY SEWER
STM	STORM SEWER	STM	STORM SEWER
D	DRAIN	D	DRAIN
G	GAS LINE (APPROX. LOC.)	G	GAS LINE (APPROX. LOC.)
T	UNDERGROUND TELEPHONE (APPROX. LOC.)	T	UNDERGROUND TELEPHONE (APPROX. LOC.)
CA	UNDERGROUND TRAFFIC CABLE (APPROX. LOC.)	CA	UNDERGROUND TRAFFIC CABLE (APPROX. LOC.)
E	UNDERGROUND ELECTRICITY (APPROX. LOC.)	E	UNDERGROUND ELECTRICITY (APPROX. LOC.)
OT	OVERHEAD WIRES	OT	OVERHEAD WIRES
OT	UNDERGROUND TRAFFIC CABLE (APPROX. LOC.)	OT	UNDERGROUND TRAFFIC CABLE (APPROX. LOC.)
OT	RIGHT-OF-WAY LIMITS	OT	RIGHT-OF-WAY LIMITS
OT	EASEMENT	OT	EASEMENT
OT	TOP OF SLOPE	OT	TOP OF SLOPE
OT	BOTTOM OF SLOPE	OT	BOTTOM OF SLOPE
OT	CATCHBASIN	OT	CATCHBASIN
OT	MANHOLE/CATCHBASIN	OT	MANHOLE/CATCHBASIN
OT	MANHOLE	OT	MANHOLE
OT	FIRE HYDRANT	OT	FIRE HYDRANT
OT	VALVE	OT	VALVE
OT	REDUCER	OT	REDUCER
OT	TEE	OT	TEE
OT	VALVE CHAMBER	OT	VALVE CHAMBER
OT	PRIVATE UTILITIES (WATERMAIN)	OT	PRIVATE UTILITIES (WATERMAIN)
OT	NATURAL GAS VALVE	OT	NATURAL GAS VALVE
OT	TRENCH DRAIN	OT	TRENCH DRAIN
OT	SIGN	OT	SIGN
OT	STOP SIGN	OT	STOP SIGN
OT	TRAFFIC LIGHT	OT	TRAFFIC LIGHT
OT	ELECTRICITY POLE	OT	ELECTRICITY POLE
OT	TELEPHONE POLE	OT	TELEPHONE POLE
OT	ELECT-TEL-STREET LIGHT POLE	OT	ELECT-TEL-STREET LIGHT POLE
OT	ELECT-TEL-TRANSFORMER POLE	OT	ELECT-TEL-TRANSFORMER POLE
OT	PRIVATE STREET LIGHT	OT	PRIVATE STREET LIGHT
OT	ELECTRICITY MANHOLE	OT	ELECTRICITY MANHOLE
OT	TELEPHONE MANHOLE	OT	TELEPHONE MANHOLE
OT	SURVEY STATION	OT	SURVEY STATION
OT	WATERMAIN INSULATION	OT	WATERMAIN INSULATION
OT	UNDERGROUND PARKING	OT	UNDERGROUND PARKING
OT	GARAGE OUTLINE	OT	GARAGE OUTLINE
OT	BOREHOLE (LOC. APPROX.)	OT	BOREHOLE (LOC. APPROX.)
OT	WORK LIMIT	OT	WORK LIMIT

1:250

0	2.5	5	10	15m
---	-----	---	----	-----

No.	Date	Description	By
1	APR 11, 2022	ISSUED FOR SITE PLAN APPLICATION	A.C.

DESIGNED BY: **CIMA+**

APPROVED BY:

ENGINEER:

CLIENT:

PROJECT NAME: **ZIBI ONTARIO BLOCK 204 OTTAWA, ONTARIO**

SHEET TITLE: **EXPOSURE SEPARATION DISTANCES AND FIRE HYDRANT COVERAGE**

DISCIPLINE: CIVIL	
DRAWN: S.C. POGGIOLI	SCALE: 1:250
DESIGNER: J. SAUVÉ	DATE: 2022/03/14
APPROVER: A. CHALMONT	APPROVER: A. CHALMONT
PROJECT No: A000931	DRAWING No:
SHEET No:	of 11

NOTE OF CAUTION

THE GEODETIC COORDINATES OF EVERY ITEM INCLUDED AS PART OF THIS DOCUMENT ARE IN NAD83 - ORIGINAL / MTM - REFERENCE SYSTEM AND HAVE NO LEGAL VALUE. THE SITE LAYOUT MUST BE COMPLETED USING THE OFFICIAL BENCHMARKS OF AN ACCREDITED LAND SURVEYOR IN THE NAD83 - ORIGINAL / MTM - REFERENCE SYSTEM.

THE UNDERGROUND FEATURES AND INFORMATION THAT APPEAR ON THE DRAWINGS WERE OBTAINED FROM THE PUBLIC UTILITY COMPANIES AND/OR FROM THE CITY EACH RESPECTIVELY.

ALL INFORMATION UNDER THE LEGEND 'EXISTING' IS FOR INFORMATION ONLY. COMPLETE OR EXACT LOCATION AND ELEVATION OF UNDERGROUND SERVICES ARE NOT GUARANTEED.

CERTAIN UNDERGROUND FEATURES ON PRIVATE PROPERTY ARE NOT SHOWN ON THE CURRENT DRAWING.

ANYONE WHO PROCEEDS WITH EXCAVATION WORK SHALL VERIFY THE EXACT LOCATION OF ALL UNDERGROUND FEATURES, BY EXPLORATORY EXCAVATIONS, AND SHALL ASSUME FULL RESPONSIBILITY IF THERE IS ANY DAMAGE THAT OCCURS DURING WORK.

THE CONTRACTOR WILL HAVE THE RESPONSIBILITY AND THE OBLIGATION TO VALIDATE, BY EXPLORATORY EXCAVATION, THE SIZE OF THE PUBLIC UTILITIES UNDERGROUND SERVICES AND TO WARN THE ENGINEER OF ANY CONFLICT WITH THE PROJECTED WORK.

C

Appendix C Wastewater Collection Calculations





PROJECT NAME: ZIBI - Ontario - Urban_Development
 CIMA+ PROJECT A000931
 CLIENT: Windmill DREAM Ontario 207 LP
 PROJECT STATUS: Site Plan Application

WASTEWATER PEAK FLOW DETERMINATION

APPLICABLE DESIGN GUIDELINES:

1. City of Ottawa Sewer Design Guidelines, 2012
2. City of Ottawa Technical Bulletin ISTB-2018-01
3. Ontario Building Code 8.2.1.3.B.

DOMESTIC CONTRIBUTIONS:

RESIDENTIAL DESIGN CRITERIA:

Residential Average Flow: 280 L/c/day
 Residential Peak Factor: Harmon Equation (Min 2.0 and Max 4.0)

Per Unit Populations:

$$P.F. = 1 + \left(\frac{14}{4 + \left(\frac{P}{1000} \right)^{\frac{1}{2}}} \right) * K$$

where:
 P=Population
 K=Correction Factor =0.8

Unit Type	Persons Per Unit
Single Family	3.4
Semi-detached	2.7
Duplex	2.3
Townhouse (row)	2.7
Apartments:	
Bachelor	1.4
1 Bedroom	1.4
2 Bedroom	2.1
3 Bedroom	3.1
Average Apt.	1.8

For the design of new systems, the average residential flow of 280 L/capita per day (as noted in Figure 4.3) shall be used. The peaking factor shall be derived from the Harmon Formula with the minimum permissible peaking factor being 2.0 and the maximum being 4.0. A correction factor of 0.8 shall then be applied to the Harmon Peaking factor.

- Infiltration Allowance (Dry weather): 0.05 L/s/effective gross ha (for all areas)
- Infiltration Allowance (Wet weather): 0.28 L/s/effective gross ha (for all areas)
- Infiltration Allowance (Total I/I): 0.33 L/s/effective gross ha (for all areas)

COMMERCIAL & INSTITUTIONAL CONTRIBUTIONS:

COMMERCIAL AND INSTITUTIONAL DESIGN CRITERIA:

Retail Average Flow: 28000 L/ha/day 2.8 L/m²/day
 Restaurant Average Flow: 125 L/seat/day
 Office Average Flow: 75 L/9.3m²/day 8.1 L/m²/day
 Office Average Flow: 75 L/c/day
 Commercial Peak Factor: 1.5

Effective Gross Area: 3 ha
 DryWeather Infiltration rate 0.05 L/s/effective gross ha
 WetWeather Infiltration rate 0.28 L/s/effective gross ha
 Total Infiltration Allowance: 0.33 L/s/effective gross ha
 Peak Extraneous Flow: 0.99 L/s

AVERAGE FLOW:

Phase	Block	Type	Unit Rate	Floor Area	Population	Number of Seats	Average Flow (L/s)	Peak Factor	Peak Flow (L/s)
1	208	Office	8.1 L/m ² /day	2527	-	-	0.24	1.5	0.35
1	205A	Residential	280 L/c/day	-	127	-	0.41	3.4	1.40
1	205A	Retail	2.8 L/m ² /day	750	-	-	0.02	1.5	0.04
2	211	Office	8.1 L/m ² /day	14480	-	-	1.35	1.5	2.03
2	211	Retail	2.8 L/m ² /day	1082	-	-	0.04	1.5	0.05
3	207	Office	8.1 L/m ² /day	6451	-	-	0.60	1.5	0.90
3	207	Retail	2.8 L/m ² /day	575	-	-	0.02	1.5	0.03
3	207	Restaurant	125 L/seat/day	-	150	-	0.22	1.5	0.33
4	206	Residential	280 L/c/day	-	447	-	1.45	3.4	4.93
4	206	Retail	2.8 L/m ² /day	799	-	-	0.03	1.5	0.04
4	204	Residential	280 L/c/day	-	390	-	1.26	3.4	4.30
4	204	Retail	8.1 L/m ² /day	1216	-	-	0.11	1.5	0.17
4	204	Amenity	8.1 L/m ² /day	1748	-	-	0.16	1.5	0.24
1	EO	Office	75 L/c/day	-	10	-	0.01	1.5	0.01
1	ZIBI	Office	75 L/c/day	-	20	-	0.02	1.5	0.03

Total 5.94 14.85
Total Dryweather Flow 15.00
Total Wetweather Flow 15.84

NOTES:

1. Base sanitary flow, population densities, and infiltration rate are based on City of Ottawa design guidelines.
2. Harmon Equation has been used to calculate the residential peak factor for sanitary flows (see above) - maximum value of 4.0.
3. Population densities per City of Ottawa Sewer Design Guidelines, 2012, Section 4.3, Table 4.2 Per Unit Populations.

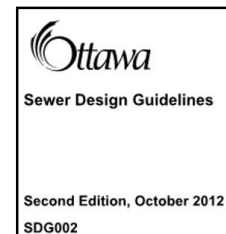

Prepared by: Zakaria Moumine, EIT Date: 2022/08/22
 PEO# 100564657

Verified by: Julien Sauvé, P.Eng. Date: 2022/08/22
 PEO# 100200100



ZIBI - Ontario - Urban_Development
A000931 (360)
HYDRAULIC CALCULATIONS FOR SANITARY SEWERS

Manning Coefficient:	0.013
Maximum permitted velocity :	3.00
Minimum permitted velocity :	0.60

Hydraulic Calculations for Sanitary Sewers

Building Flow	Section	Dia.	Length	Slope	Capacity (full)	Velocity (full)	Flow	Cumulative Flow	Velocity (actual)	% Full
		mm	m	%	m ³ /s	m/s	m ³ /s	m ³ /s	m/s	
Building 202 / 205B	SAN-109 to SAN-108	250	30.6	0.35%	0.035	0.72	0.00665	0.00665	0.55	19%
	SAN-108 to SAN-107	250	9.9	0.35%	0.035	0.72	0.00000	0.00665	0.55	19%
Building 204 / 201	SAN-107 to SAN-106	250	57.2	0.35%	0.035	0.72	0.00916	0.01581	0.70	45%
	SAN-106 to SAN-105	250	22.2	1.00%	0.059	1.21	0.00000	0.01581	1.02	27%
	SAN-105 to SAN-104	250	9.2	1.10%	0.062	1.27	0.00000	0.01581	1.05	26%
Building 206 / 207 / EO	SAN-104 to SAN-103	250	107.8	1.50%	0.073	1.48	0.00624	0.02205	1.28	30%
	SAN-103 to SAN-102	250	67.3	0.42%	0.039	0.79	0.00000	0.02205	0.81	57%
ZIBI / 205a / 208/ 209	SAN-102 to SAN-101	250	18.3	0.45%	0.040	0.81	0.00462	0.02667	0.86	67%
Building 211 / 213	SAN-101 to SAN-100A	250	14.8	0.50%	0.042	0.86	0.00798	0.03465	0.96	83%
Building 212	SAN-100A to SAN-401A	300	75.9	0.23%	0.047	0.66	0.00520	0.03985	0.74	85%
Building 214 / 215	SAN-401A to SAN-402A	1,500	61.5	0.23%	3.393	1.92	0.00340	0.04325	0.66	1%
	SAN-402A to SAN PS	525	4.2	3.90%	0.849	3.92	0.00000	0.04325	2.05	5%

Remarks :

- Slope of 2.00% has been assumed for all building connections.
- Sewer runs generally do not achieve minimum flushing velocities (0.6m/s) under actual peak flow conditions, where the height of flow is less than 30% of the sewer diameter in accordance with City of Ottawa and MOE guidelines. A flushing program is to be implemented.
- Sanitary Flows used for Future development are from the Master Servicing Study

Prepared by: Julien Sauvé, P.Eng
 PEO# 100200100

Date: 2022/08/22

Verified by: André Chaumont, P.Eng
 PEO# 90409194

Date: 2022/08/22

March 14, 2022

Ms. Taryn Glancy, P.Eng.
Project Manager
Zibi
6 Booth Street, Albert Island
Ottawa, ON K1R 6K8

Dear Taryn:

Subject: Preliminary Design for the Pumping Station to Service the Zibi Development on Chaudière Island - City of Ottawa

Hatch is pleased to present the Preliminary Design Report for the Zibi Permanent Pumping Station in the City of Ottawa.

We trust that this report is sufficient for your review and approval. Should you have any further questions, please do not hesitate to contact us.

Very truly yours,



Peter Rüsç, M.Eng., P.Eng., PMP
Municipal Flow Assurance Lead - North America
T 905.940.5497
peter.rusch@hatch.com

Zibi Pumping Station, Chaudière Island, City of Ottawa

Preliminary Design Report

HATCH

Copyright © 2021 - 2022, all rights reserved

Hatch Ltd
15 Allstate Parkway
Suite 300
Markham, ON L3R 5B4
CANADA
T 905.943.9600

Revision and Version Tracking

Report Title: Zibi Pumping Station, Chaudière Island, City of Ottawa – Preliminary Design Report

Submission Date: March 14, 2022

Version #	Filename:	Author	Checker	Approver	Date:
V0.50	Draft 1: Zibi Pumping Station Chaudière Island, Ottawa - Preliminary Design Report	P. Rüsç / A Gibbs	P. Rüsç	P. Rüsç	July 30, 2021
V0.90	Zibi Pumping Station Chaudière Island, Ottawa - Preliminary Design Report	P. Rüsç / A Gibbs	P. Rüsç	P. Rüsç	November 26, 2021
V0.95	Zibi Pumping Station Chaudière Island, Ottawa - Preliminary Design Report	P. Rüsç / A Gibbs	P. Rüsç	P. Rüsç	December 2, 2021
V1.00	Zibi Pumping Station Chaudière Island, Ottawa - Preliminary Design Report	P. Rüsç / A Gibbs	P. Rüsç	P. Rüsç	March 14, 2022



Peter Rüsç: Project Engineer

 This document has been formatted for double side printing.

This document has been prepared for the titled project or named part thereof and should not be relied upon or used for any other project without an independent check being carried out as to its suitability and prior written authorization of Hatch being obtained. Hatch accepts no responsibility or liability for the consequence of this document being used for a purpose other than the purposes for which it was commissioned. Any person using or relying on the document for such other purpose agrees, and will by such use or reliance be taken to confirm their agreement to indemnify Hatch for all loss or damage resulting there from. Hatch accepts no responsibility or liability for this document to any party other than the person by whom it was commissioned.

To the extent that this report is based on information supplied by other parties, Hatch accepts no liability for any loss or damage suffered by the client, whether through contract or tort, stemming from any conclusions based on data supplied by parties other than Hatch and used by Hatch in preparing this report.

Table of Contents

Cover Letter	<i>i</i>
1 Introduction	1
2 Methodology	1
2.1 Capacity of the Pumping Station	1
3 Design of the Pumping Station	1
3.1 Existing System Components / Elevations / Other Requirements	1
3.2 Approach Pipe	2
3.3 Station Configuration	2
3.4 Sizing of the Wet Well	2
3.5 Storage Requirements	2
3.6 Station Levels	3
3.7 Sizing and Pressure Class of the Forcemain, and System Curve	3
3.8 Pump Selection	4
3.9 Variable Frequency Drives	4
3.10 Emergency Backup Times and Emergency Overflow	4
3.11 Regular and Emergency Maintenance	5
3.12 Operation, Maintenance and Service Manuals	5
4 Electrical Works	5
4.1 Power Supply	5
4.2 Control Panel	5
4.2.1 Operation	5
5 Confined Space Entry Requirements	6

Appendices:

Appendix 1: Figures

List of Figures:

FIGURE 1: SITE PLAN

FIGURE 2: SYSTEM SCHEMATIC

FIGURE 3: PROCESS MECHANICAL LAYOUT AND DETAILS

FIGURE 4: SINGLE LINE DIAGRAM

FIGURE 5: ELECTRICAL LAYOUT AND DETAILS

FIGURE 6: STRUCTURAL LAYOUT AND DETAILS

Appendix 2: System Curve and Calculations

Appendix 3: KSB Pump Data Sheet

Appendix 4: E-mail RE: System Flow

Appendix 5: Generator Sizing TM-1

1 Introduction

This report has been prepared for Zibi for the preliminary design of a new sewage pumping station to be located on Chaudière Island in the City of Ottawa. A site plan is attached in Appendix 1: Figure 1. The pumping station will service the planned Zibi development on Chaudière Island.

The internal collection system will collect sewage by gravity to a low point near the proposed pumping station; refer to the site plan for details. The proposed pumping station is designed to lift the collected sewage through two existing forcemains to a manhole located on Brickhill Street (near Pimisi Station) in Ottawa, to be treated elsewhere.

The purpose of this report is to:

- Provide the design criteria and rationale used to provide a preliminary design for the sewage pumping station;
- List specific requirements incorporated in the design;
- Outline the preliminary arrangement of the pumping station and site requirements;

This report is to be reviewed, and submitted to the City of Ottawa for review and comments for inclusion into the final design. This report is also to be submitted as part of the Environmental Compliance Approval (ECA) application.

2 Methodology

2.1 Capacity of the Pumping Station

Zibi, after review of the phasing of the development, requested a final capacity of the pumping station at 45 L/s, with a likely sewage flow of 30 to 35 L/s. Refer to an e-mail from Zibi in Appendix 4.

In line with the City of Ottawa requirements, a wet well with submersible pumps with an underground control valve chamber will form the core pumping station. The pumping station will be equipped with 2 duty and 1 standby pumps.

The invert of the incoming sewer and the forcemain is dictated by the existing ground levels / sewer designs and the requirements for storage in the wet well / approach pipe of the pumping station. The final inverts were set by Hatch, taking the incoming sewer, storage requirements, and operational levels / volumes into account.

For approval purposes, the firm capacity of this pumping station will be 45 L/s, with an expected peak flow of 30-35 L/s. Refer to Section 3.3 for a detailed description of pump/forcemain combinations and resulting capacities.

3 Design of the Pumping Station

3.1 Existing System Components / Elevations / Other Requirements

The MECP Design Guidelines (online version) call for a flow velocity of at least 0.6 m/s in forcemains, however Hatch's preference is for a velocity of above 1.0 m/s (ideally 1.25 m/s to 1.5 m/s) to maintain adequate self-cleaning velocities in the forcemain. The forcemains are pre-existing for this project, with an ID of 201 mm. This will result in a velocity of 0.95 m/s (at 30 L/s) and 1.42 m/s at 45 L/s. Therefore, the flow velocity requirements of the City and the MECP will be fully met.

Since there is inadequate storage in existing sewers and manholes to allow for emergency storage exceeding 30 minutes, a storage pipe will provide additional storage for the pumping station. In conjunction with a dedicated diesel drive standby generator, the storage will primarily serve to provide additional time to troubleshoot the station, should there be a failure / outage. An emergency overflow has been indicated upstream of the pumping station, connecting to an existing storm sewer. An overflow elevation of 47.109 m has been provided in as-built drawings for the sewers on site. We understand that this level was set to ensure that no basements will be flooded. The station will be designed for a minimum

time-to-overflow of 30 minutes at 45 L/s, which will result in a minimum time-to-overflow of 45 minutes at 30 L/s. Since the expected flows are at the lower end of the design range, the actual storage time will be at the higher end of the design range.

3.2 Approach Pipe

The pumping station uses an approach pipe to bridge the elevation difference to the pumping station wet well from the end of the storage pipe, thus creating good suction conditions for the pumps. The key purpose is to create smooth flow conditions that will not entrain air, to avoid issues associated with air in the forcemain. The approach pipe is designed to have a hydraulic jump at the junction of the incoming supercritical flow and the subcritical flows into the wet well. This will allow for self-cleaning of the approach pipe as sewage cycles between the operating levels.

3.3 Station Configuration

After a detailed analysis, it was determined that three pumps (2 duty, 1 standby) appears to be a more desirable station configuration. With this arrangement, two pumps are required to meet duty of 45 L/s using a single forcemain. Each pump can pump 30 -35 L/s using a dedicated forcemain. Therefore, with two pumps and two forcemains in operation a maximum capacity of approximately 60-70 L/s can be achieved. This results in a more energy efficient design, while accommodating flow variations between 30 and up to 50 L/s with two pumps and two forcemains in service and still meeting the desired 45 L/s with a single forcemain in service. The third pump operates as a standby pump in all cases.

3.4 Sizing of the Wet Well

Sizing of the wet well was performed for a single pump pumping through a dedicated forcemain achieving a flow of up to 35 L/s. Other operational scenarios are less severe and will be accommodated by this arrangement. The wet well capacity required to achieve a given pump cycle time, with one pump in service, can be calculated as follows:

$$V = \frac{T_c \cdot Q}{4}$$

Where:

V = wet well volume in L;

T_c = Pump Cycle Time in seconds;

Q = Pump discharge rate, in L/s

Since normally three pumps are available, 8 starts and stops per hour equally spread over 3 pumps were used to calculate the wet well volume (for pumps of this size, generally between 15 and 30 starts per hour are allowed). The active wet well volume required can be calculated as:

$$V = \frac{T_c \cdot Q}{4} = \frac{450s \cdot 35 L/s}{4} = 3940L$$

Given the physical size of the pumps, and operational volume requirements, Hatch recommends a wet well within a precast chamber 2400mm x 3000mm to fit the pumps and piping. Allowing for 90% of the area being usable (to allow for some benching, equipment), this provides an area of:

$$A = 0.9 * l * w = 0.9 * 2.438 * 3.048 = 6.69m^2$$

A live wet well depth may be calculated as:

$$H = \frac{V}{A} = \frac{3.94m^3}{6.69m^2} = \sim 0.59m$$

3.5 Storage Requirements

In the event of an equipment failure the station will have the storage capacity to prevent incoming sewage flow from spilling into the storm system for at least 30 minutes. Significant storage within the wet well is not practical due to site considerations, hence a storage pipe was designed. The storage pipe is a 51.7m

1500 mm sewer between SANMH 401A and SANMH 402A. Low flow benching has been added to the storage pipe to accommodate all sewage flows under normal operating conditions (up to 45 L/s). The storage pipe elevations have been set to provide full storage at 100 mm below the overflow to the storm sewer. The maintenance hole SANMH 401A will be increased in diameter to 2400mm and the maintenance hole SANMH 402A will be increased in diameter to 3000mm. Hatch has confirmed both of these maintenance holes can accommodate joining to a 1500 mm sewer. The storage pipe will, net of the low flow channel and the benching, have a storage volume of 1.55 m³/m.

3.6 Station Levels

The system operating levels are controlled with a combination of an ultrasonic level sensor and backup floats. The low water level (LWL) is set at the sequent depth for 45 L/s of the approach pipe, this level is set at 44.35m. LWL1, at which Pump 1 starts, is set at 44.95m, 0.60m higher than LWL. Pump 1 will be set to run at 25 L/s to reduce energy consumption while ensuring suitable conveyance velocities in the forcemain. LWL2, is set at 45.15m, at which point Pump 2 starts at 25 L/s and the first pump continues to run at 25 L/s for a combined duty of up to 50 L/s. Should the sewage level further increase, to high water level (HWL), set 0.20m above the LWL2 at 45.35m, both pumps to run at full speed, 30-35 L/s each for a total pumpage of 60-70 L/s. Should sewage levels continue to rise, the alarm high water level (HHWL) will be reached. This arrangement allows for additional emergency capacity to prevent overflows, and should be utilized unless the discharge cannot be accepted by the downstream sewer. The HHWL has been set to coincide with the top of the low flow channel in the storage pipe. The low-low water level is set 0.20m below the LWL to raise an alarm and also turn of the pump. A float is set 0.10m below the LLWL as a backup to turn off the pumps in the event of a transducer failure. The wet well invert (station floor) is 0.55m below the LLWL to allow for variety of pumps to be installed and allow for construction tolerances.

Table 1 - Level Elevation Summary

Level	Elevation	Notes
Station Floor	43.60m	
Low-Low Water Level	44.15m	Alarm level (float at 44.05m).
Low Water Level	44.35m	First pumps stops.
Low Water Level 1	44.95m	First pump starts (~25 L/s). Second pump stops.
Low Water Level 2	45.15m	Second pump starts (~2 x 25 L/s, from 1 x 35 L/s).
High Water Level	45.35m	Two pumps running each at 30 to 35 L/s.
High-High Water Level	45.55m	Alarm level (float at 45.65m).

Should only a single forcemain be operational, 45 L/s capacity will be met with 2 pumps running at full speed. Under peak flow conditions this may utilize some storage, however it would be expected that under circumstances where only a single forcemain is available, the station will be manned and that vac-trucks will be kept on standby.

3.7 Sizing and Pressure Class of the Forcemain, and System Curve

The forcemains are existing, and the sizing was indicated above, as were the expected velocities. A review of the forcemain profile confirmed that the forcemains are not continuously rising to the high point; this usually indicates a potential for transients. Variable frequency drives (VFDs) will be used in the station, primarily to improve energy consumption and to allow for longer runtimes. In addition, they will aid in limiting transients during normal operation by ramping up and ramping down the pump speed to control sewage flow rates. VFDs can also be used increase operational speed to perform controlled and periodic flushing of the forcemains if full speed pumping operation does not regularly occur.

The static head of this pumping station will range between 15.1m (for High-High Water Level) and 16.3 m during normal operation (Based on Low Water Level) based on the operating levels as defined in section 3.6 above, and the forcemain discharge elevation of 60.69 m. Forcemain distances and losses are calculated based on as-built drawings sent to Hatch.

A system curve has been calculated from 0-80 L/s using the HW-C factors of 120, 130 and 140 for the 200 mm SDR-26 PVC forcemain for single and dual forcemain operation. Minor losses were estimated by allowing for a 'k' value of 2 for fittings inside the pumping station and 16.1 for the forcemains. This 'k' value results in an additional dynamic head of 1.8 m at a flow rate of 45.0 L/s.

Friction losses are noted as follows, at 45 L/s and 30 L/s respectively:

- Hazen Williams C (HW-C) = 120: 14.1 m and 6.7 m
- HW-C = 130: 12.2 m and 5.7 m
- HW-C = 140: 10.6 m and 5.0 m

From the friction loss difference, and the general transient understanding, it is advisable to limit pumping capacity to 30 L/s, unless higher capacities are required.

A graph of the system curve is attached as Appendix 1: Figure 3. The following lines have been plotted:

- Maximum static head, and friction losses based on a HW-C of 120, along with minor losses;
- Intermediate static head (LWL1), and friction losses based on a HW-C of 130, along with minor losses;
- Minimum static head (OWL), and friction losses based on a HW-C of 140, along with minor losses.

Since the forcemain is < 300 mm diameter, the pump selection was based on the maximum curve. The full calculations are shown in Appendix 2.

3.8 Pump Selection

From the hydraulic system curve, three identical pumps have been pre-selected for the proposed pumping station – these are KSB 80-253/224XFG-K. Hatch has reached out to other manufacturers and the option presented is currently deemed the most suitable selection for this application.

Each pump is a submersible wastewater pump with a 255 mm diameter impeller. It operates with 600 V, 60 Hz, 3 phase motor with an output rating of 18.64 kW at 1777 rpm. These pumps require a minimum water level of 0.45 m, therefore the floor level proposed in section 3.6 of 0.75 m below the LWL is suitable.

With submersible pumps the NPSH requirements are met by designing the station to operate above the minimum water level. Hatch has calculated the NPSH available at the station and has confirmed that it will exceed the NPSH required by the pump manufacturer by a suitable margin for flows up to ~ 50 L/s per pump. The additional submergence below the LLWL alarm level contributes to having increased NPSH margin available.

The data sheet for the proposed pump is attached in Appendix 3. The pump curve for single and two pump operation has been plotted on the system curve derived in Section 3.7 above.

3.9 Variable Frequency Drives

As noted above, VFD drives will reduce energy costs, and transient issues during normal operation. In addition, the VFDs will lessen the inrush current to the pumps, and will allow for a higher number of starts per hour.

3.10 Emergency Backup Times and Emergency Overflow

Storage is available above the HHWL in the wet well, storage pipes and maintenance holes SANMH 401A and SANMH 402A. Any storage upstream of SANMH 401A was considered negligible.

The overflow elevation of the system was presented to Hatch as 47.109m on drawing, "PLAN AND PROFILE OF ZAIDA EDDY PRIVATE, SHEET No. 6" provided by Zibi. It is expected that the City/MECP will require a minimum emergency storage of 30 minutes of sewage flows, this would require a total storage of 81,000 L of storage. The storage time prior to overflow is 41 minutes at the full incoming flow condition, and is 53 minutes when the incoming flow rate is 35 L/s.

In the event of the surrounding water exceeding the 100 year flood level (46.81m), the system overflow may be compromised. A duckbill check valve should be installed on the overflow connection in SANMH 402A to eliminate water flowing into the station through the overflow connection during flood conditions.

3.11 Regular and Emergency Maintenance

With a three pump / two forcemain configuration, the pumps can either pump through both forcemains concurrently, or one at a time. With a flow rate of 25 L/s for single pump operation, operation of a single pump / two forcemain will result in low flow velocities. It is therefore proposed that the valves in the control valve chamber be adjusted to suit operation of a pump / forcemain combination, with 1 pump assigned to one forcemain and the other 2 pumps to the other forcemain. It is recommended that the assignment is changed every 6 month as part of regular maintenance. A selector switch will be incorporated into the pump controls to ensure that the pumps will function correctly.

3.12 Operation, Maintenance and Service Manuals

Access for maintenance personnel to the wet well will be provided through a hinged access cover with a locking device. Standard manhole ladders, set in the pre-cast concrete chamber, as well as safety platforms will be in accordance with applicable design standards for the given depth of the wet well. Three additional access openings, with locks and hinged covers, will facilitate maintenance of the pumps.

The wet well and the control valve chamber will both be located underground with locked access hatches. Therefore, additional security measures such as fencing should be unnecessary.

Operation, Maintenance and Service Manuals will be provided in accordance with the requirements of Section 7.1.5.3 of the City of Ottawa Pumping Station Design Guidelines. These manuals should be kept at a convenient location near the pumping station.

4 Electrical Works

4.1 Power Supply

A dedicated 3-phase supply will be made available for the pumping station. Details of the power supply requirement are provided in Appendix 1. There is an existing generator for the station, that was purchased by Zibi for the temporary pumping station. This generator was sized with the permanent station in mind and Hatch has confirmed it can be used at the permanent station. More information on the backup generator is available in Appendix 5.

4.2 Control Panel

The control panel will contain the control schematic (3-position mode selector switch, push-buttons and any other ancillary equipment required to provide a safe pump control). These components will be supplied as loose equipment, in the same package as the submersible pumps. The general contractor will install, commission and start-up the control system as per the pump control supplier documentation.

4.2.1 Operation

The pump control shall be based on the “Lead-Lag” principle. The operator can select three modes of operation from 2 selector switches:

- MANUAL mode: Each pump can be started and stopped individually, from push-buttons;
- AUTO mode: Pumps start and stop as per the “Lead-Lag” principle.
At the first start Pump P-1 will be the lead pump and will start at the LWL1 level. Should the level reach LWL2, then the lag pump P-2 starts. The lag pump will stop once the LWL1 is reached. The lead pump stop once the LWL level is reached. Once both pumps are stopped, pump P-2 becomes the “lead” pump and P-3 the “lag” pump and P-1 becomes the standby pump. After each operation, the “lead” position alternates.
- OFF position: All pumps are stopped.

The control panel will include the LIT-1 ultrasonic level transducer. This transducer will provide the level inputs, (LWL, LWL1, LWL2, HWL) to be used to control the pumps.

Floats will be used to control the alarm levels (LLWL, HHWL) in addition to the ultrasonic transducer, and as backup to the transducer. An alarm will activate when the floats are used to control the pumps indicating the ultrasonic transducer is in a state of failure.

The controls for the submersible pumps will be provided by the pump manufacturer.

Each pump circuit is fitted with a thermomagnetic circuit breaker with instantaneous magnetic trip and adjustable overload relay.

Control power for pump schematic is to be provided from a Un-interruptible Power Supply (UPS). The UPS will power the level transmitter and auto-dialer.

A heating element with a thermostat will control the temperature of the control panel.

The following items shall also be included in the motor control panel:

- Duplex receptacle with ground fault protection;
- Lightning arrester;
- Motor temperature surveillance;
- Intrinsically safe relays for level switches installed in classified area;
- Pump Protection Relays for submersible motor protection;
- Smoke detector for smoke alarm;
- Manual transfer switch for generator operation of the station;
- Dry contacts for the alarm function of high-high water level, pump faults, power failure, smoke alarm, diesel generator fault, illegal entry is to be wired to the alarm control panel.

The time totalizer and event counter will enable staff to monitor the performance of pumps. A flow meter can be provided if required, however due to the limited space on site, and no receiving SCADA endpoint is not recommended. It is recommended that volume calculations are based on runtimes.

Each pump will be monitored for failing to respond to a "start" command. The pump failing to respond will be locked out and the lag pump will assume the lead duty position.

A separate "Alarm Control Panel" (ACP) will be provided on the outside of the pumping station main control panel. The ACP will house the alarming control logic required and a programmable auto-dialer to relay alarms. The dialler will store at least 4 pre-set emergency numbers, and will dial in case of an alarm until the dialed call is acknowledged. As a backup, an industrial outdoor strobe/audible alarm unit will also be mounted on the outside of the ACP that will be activated only in case of an auto-dialer failure, or if the auto-dialer alarm is not acknowledged within an adjustable short period of time. Alarm notifications instructions will also be added near the strobe light/audible alarm for manual alarming. The ACP can also be replaced (in future) with a SCADA system, should this become a requirement.

5 Confined Space Entry Requirements

The proposed wet well pumping station is classified as "confined space" similar to any underground maintenance hole or chamber.

Entry to the wet well is subject to the following requirements:

- Ontario Regulation 632/05 (Confined Spaces)
http://www.elaws.gov.on.ca/html/regs/english/elaws_regs_050632_e.htm
- Confined Spaces Guidelines prepared by the Ontario Ministry of Labour
http://www.labour.gov.on.ca/english/hs/pdf/gl_confined.pdf

Entry procedures shall be developed by the owner of the Pumping Station in accordance with the above noted regulations and laws, and safety equipment shall meet legal requirements and be maintained in strict accordance with manufacturer's requirements.

Appendix 1

- Figures
- Site Plan
 - System Schematic
 - Process Mechanical Layout and Details
 - Electrical Single Line Diagram
 - Electrical Layout
 - Structural Details

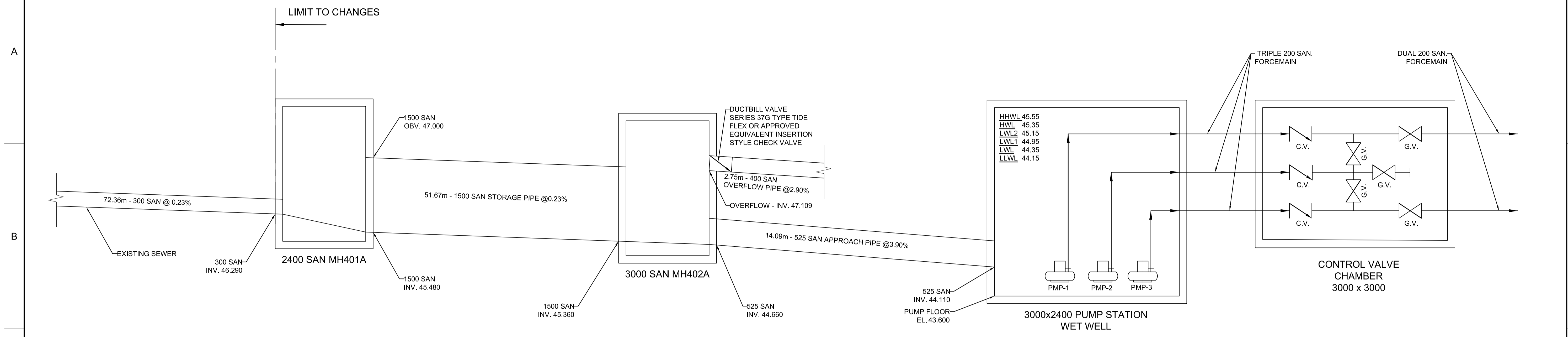

SCHEMATIC DIAGRAM
N.T.S.

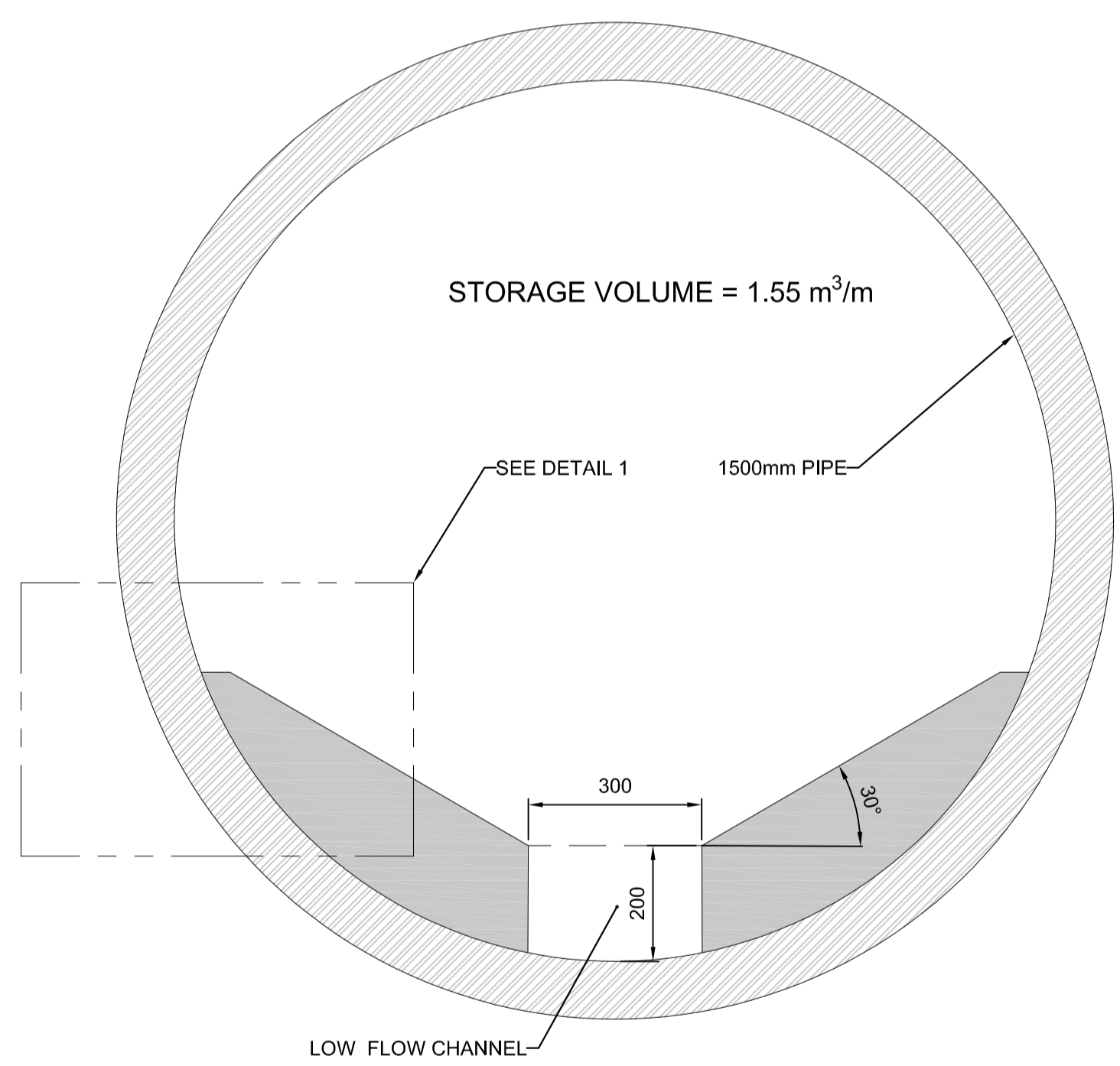
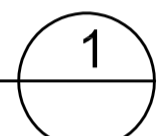

BENCHING DETAILS - STORAGE PIPE
1:10

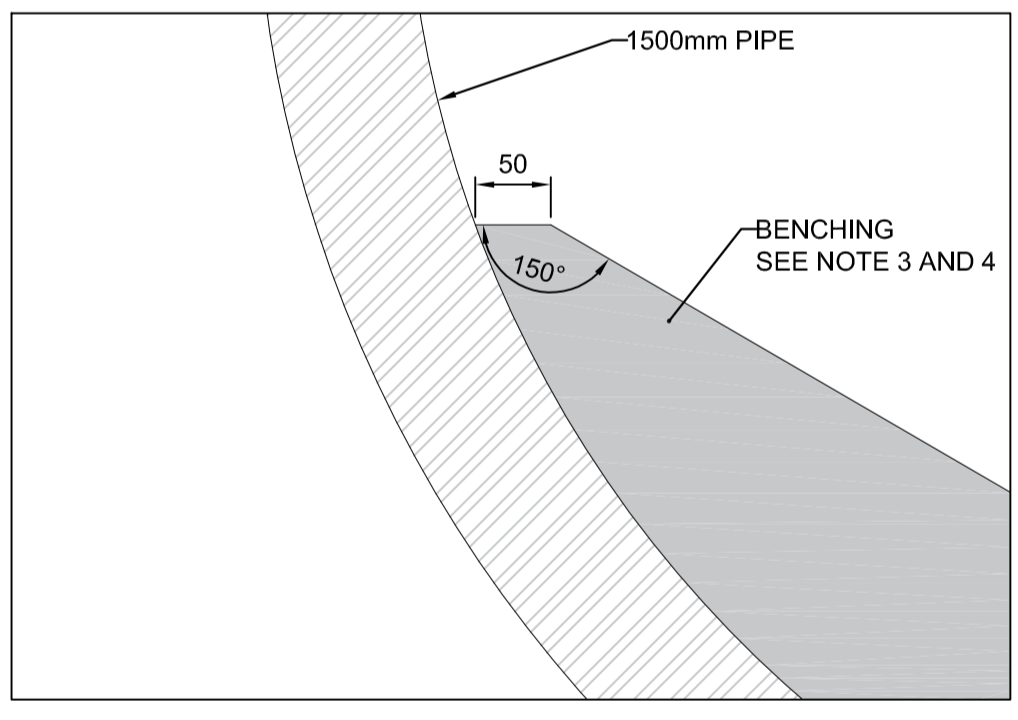
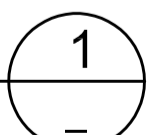

DETAIL 1
1:5

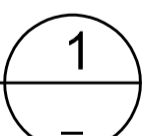

- GENERAL NOTES:
- ALL ELEVATIONS SHOWN ARE IN METERS.
 - ALL PIPE SIZES AND DIMENSIONS ARE SHOWN MILLIMETERS.
 - ALL CONCRETE BENCHING SHOULD CONFORM TO CAN 3-A23.3-M77 (LATEST REVISION):
- 28 DAY STRENGTH: 30MPa
- SLUMP: 50mm
- ENTRAINED AIR: 6%
 - BENCHING TO BE 30MPa CONCRETE AS PER NOTE 3. ALL BENCHING SHALL BE RE-ENFORCED AS PER CSA A23.3 FOR SLABS

FOR CLIENT REVIEW

THIS DRAWING WAS PREPARED FOR THE EXCLUSIVE USE OF WINDMILL DREAM ONTARIO LP ("ZBI") AND IS ISSUED PURSUANT TO THE ZBI WINDMILL DREAM PUMPING STATION AGREEMENT BETWEEN ZBI AND HATCH LTD. ("HATCH"). UNLESS OTHERWISE AGREED IN WRITING WITH ZBI OR SPECIFIED ON THIS DRAWING, HATCH DOES NOT ACCEPT AND DISCLAIMS ANY AND ALL LIABILITY OR RESPONSIBILITY ARISING FROM ANY USE OF OR RELIANCE ON THIS DRAWING BY ANY THIRD PARTY OR ANY MODIFICATION OR MISUSE OF THIS DRAWING BY ZBI. AND BY THIS DRAWING IS CONFIDENTIAL AND ALL INTELLECTUAL PROPERTY RIGHTS EMBODIED OR REFERENCED IN THIS DRAWING REMAIN THE PROPERTY OF HATCH.



ZIBI WINDMILL DREAM ONTARIO
PUMPING STATION
PROCESS MECHANICAL
SCHEMATIC PLAN AND DETAIL

D	FOR CLIENT REVIEW	J.B.	P.R.	03-14-2022	LEAD DISC. ENG.			
C	FOR CLIENT REVIEW	J.B.	P.R.	12-03-2021	ENG. MANAGER			
B	FOR CLIENT REVIEW	J.B.	P.R.	11-26-2021	PROJ. MANAGER			
A	FOR CLIENT REVIEW	J.B.	P.R.	11-19-2021				

No.	DESCRIPTION	BY	CHK'D	DATE	ROLE	NAME	SIGNATURE	DATE

DRAWING No.	DRAWING TITLE	REG. PROFESSIONAL

DRAFTSPERSON	J.BAJAGIC	NR	11-19-2021
DESIGNER	A.GIBBS	NR	11-19-2021
CHECKER	A.GIBBS/P.RUSCH		11-19-2021
DESIGN COORD.			-
RESP. ENG.	P.RUSCH		11-19-2021
LEAD DISC. ENG.			-
ENG. MANAGER			-
PROJ. MANAGER	P.RUSCH		11-19-2021

SCALE: NTS OR AS NOTED
DWG. No. H364639-0000-240-262-0001
REV D

GENERAL NOTES:

- ALL ELEVATIONS SHOWN ARE IN METERS.
- ALL PIPE SIZES AND DIMENSIONS ARE SHOWN MILLIMETERS.
- REFER TO SITE PLAN DRAWING H364639-0000-220-251-0001 FOR POSITION AND ORIENTATION OF PUMPING STATION.
- ALL PIPES TO HAVE FLEXIBLE JOINTS OUTSIDE OF THE PUMPING STATION. FORCEMAIN JOINT IS TO BE CONSTRUCTED WITH TIE RODS.
- ALL VICTAULIC COUPLINGS FOR STAINLESS STEEL SHALL BE STYLE 77. ALL VICTAULIC COUPLINGS SHALL BE EPOXY COATED OR HOT DIP GALVANIZED.
- ALL CONCRETE BENCHING SHOULD CONFORM TO CAN 3-A23.3-M77 (LATEST REVISION):
 - 28 DAY STRENGTH: 30MPa
 - SLUMP: 50mm
 - ENTRAINED AIR: 6%
- CHAMFER ALL EXPOSED CONCRETE CONES/EDGES 20mm.
- BACKFILL SHALL BE FREE-DRAINING MATERIAL (MTO GRANULAR "B" OR APPROVED EQUAL), MINIMUM 300mm, THICKNESS, AND BE COMPACTED TO 100% STANDARD PROCTOR DENSITY.
- BACKFILLING SHALL PROCEED UNIFORMLY ON ALL SIDES OF THE STRUCTURE (AS APPLICABLE), IN MAX. 0.2 METER LAYERS AND WITH MAX. 0.5 METER DIFFERENCE IN ELEVATION BETWEEN LEVELS BEHIND ANY SIDE TO BE BACKFILLED.
- REFER TO SPECIFICATIONS FOR PUMP MODEL
- ELECTRICAL PANEL TO BE HOUSED IN SEPARATE ENCLOSURE.
- BENCHING TO BE 30MPa CONCRETE AS PER NOTE 6. ALL BENCHING SHALL BE RE-REINFORCED AS PER CSA A23.3 FOR SLABS

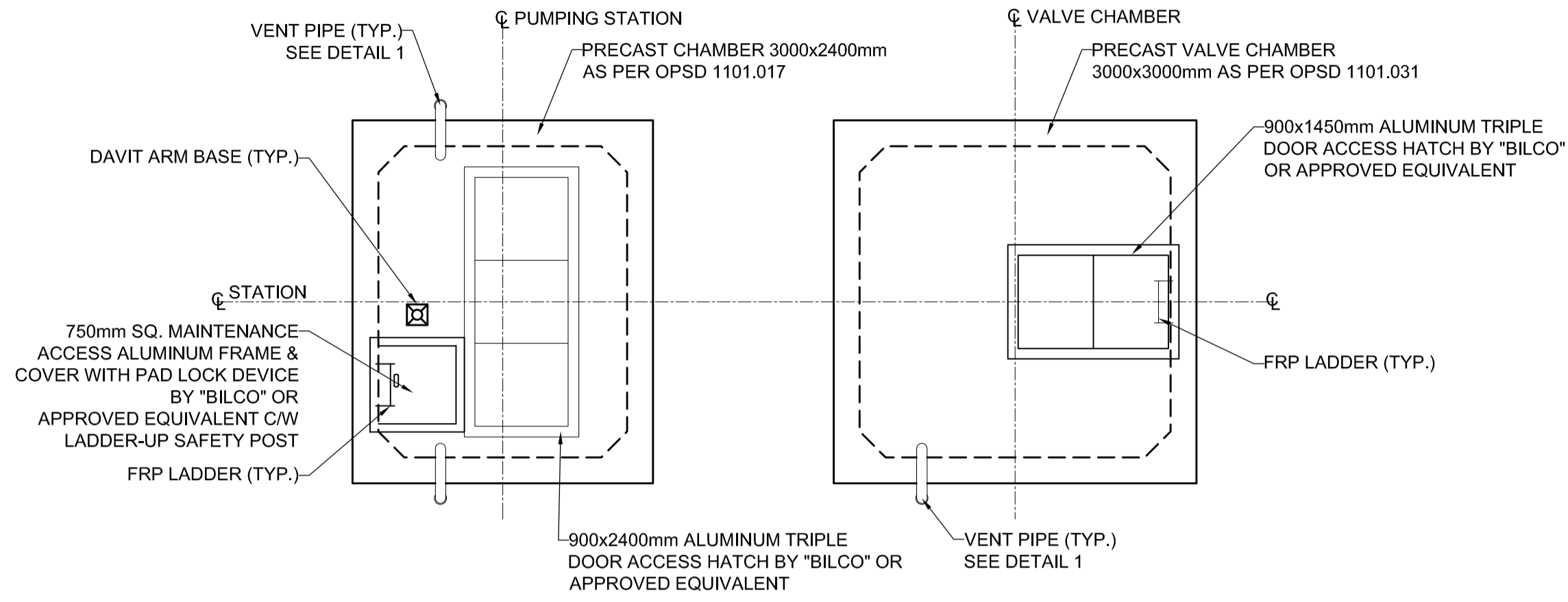
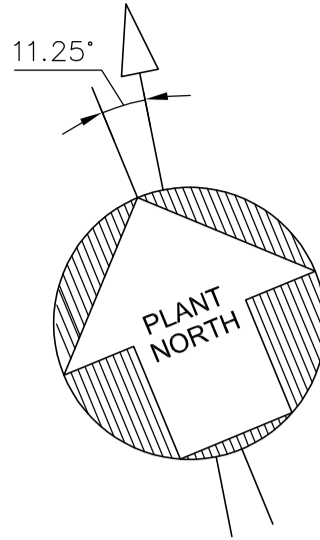

ROOF PLAN 1

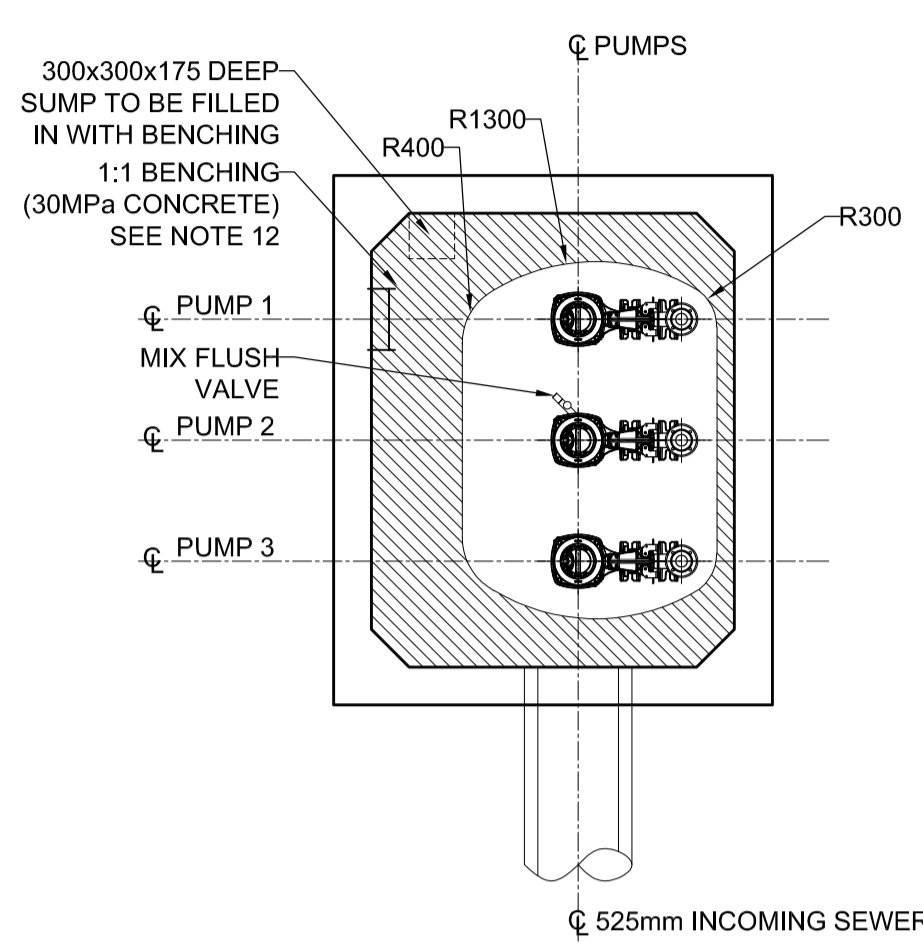

BENCHING PLAN 3

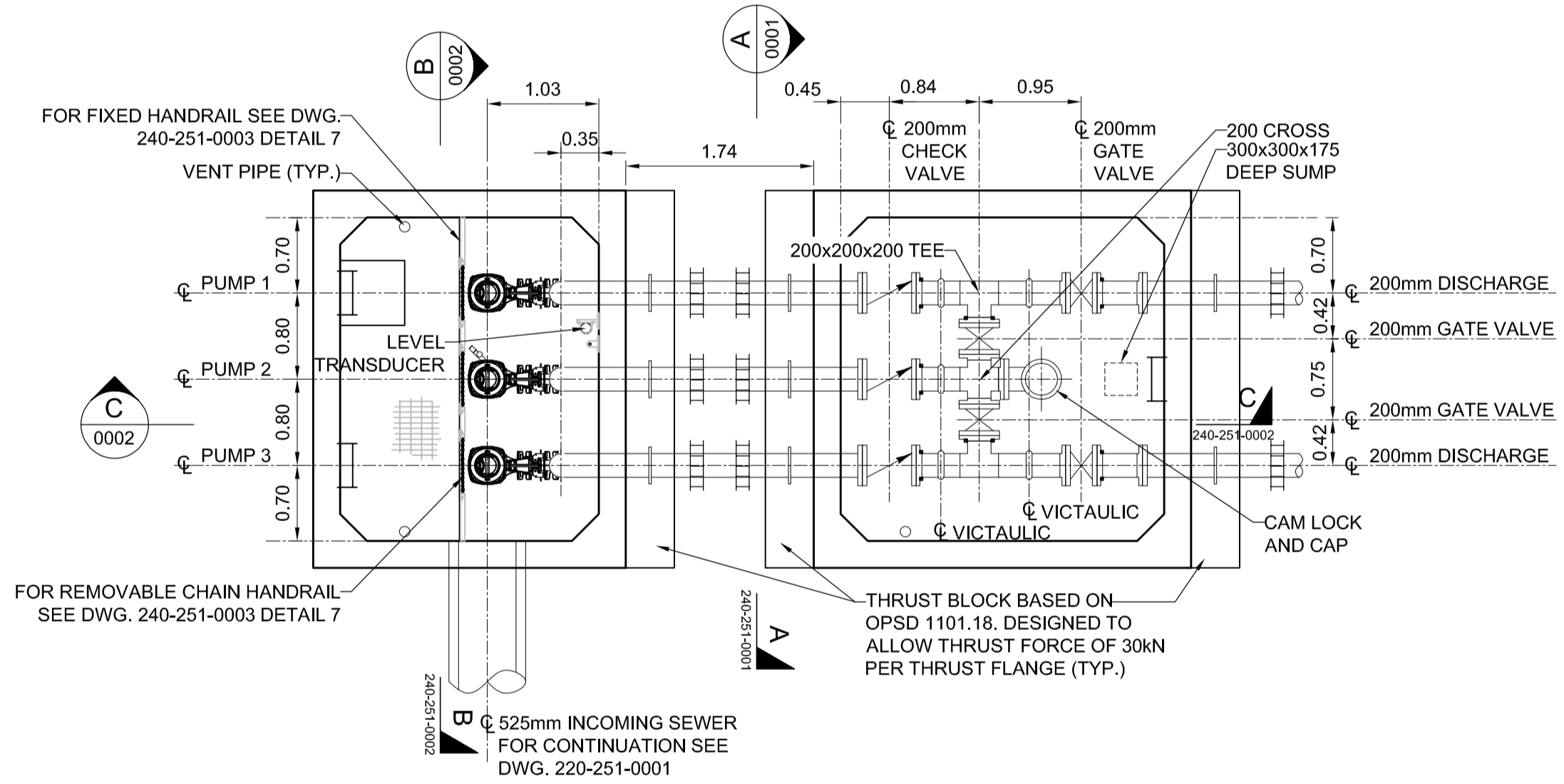

FLOOR PLAN 2

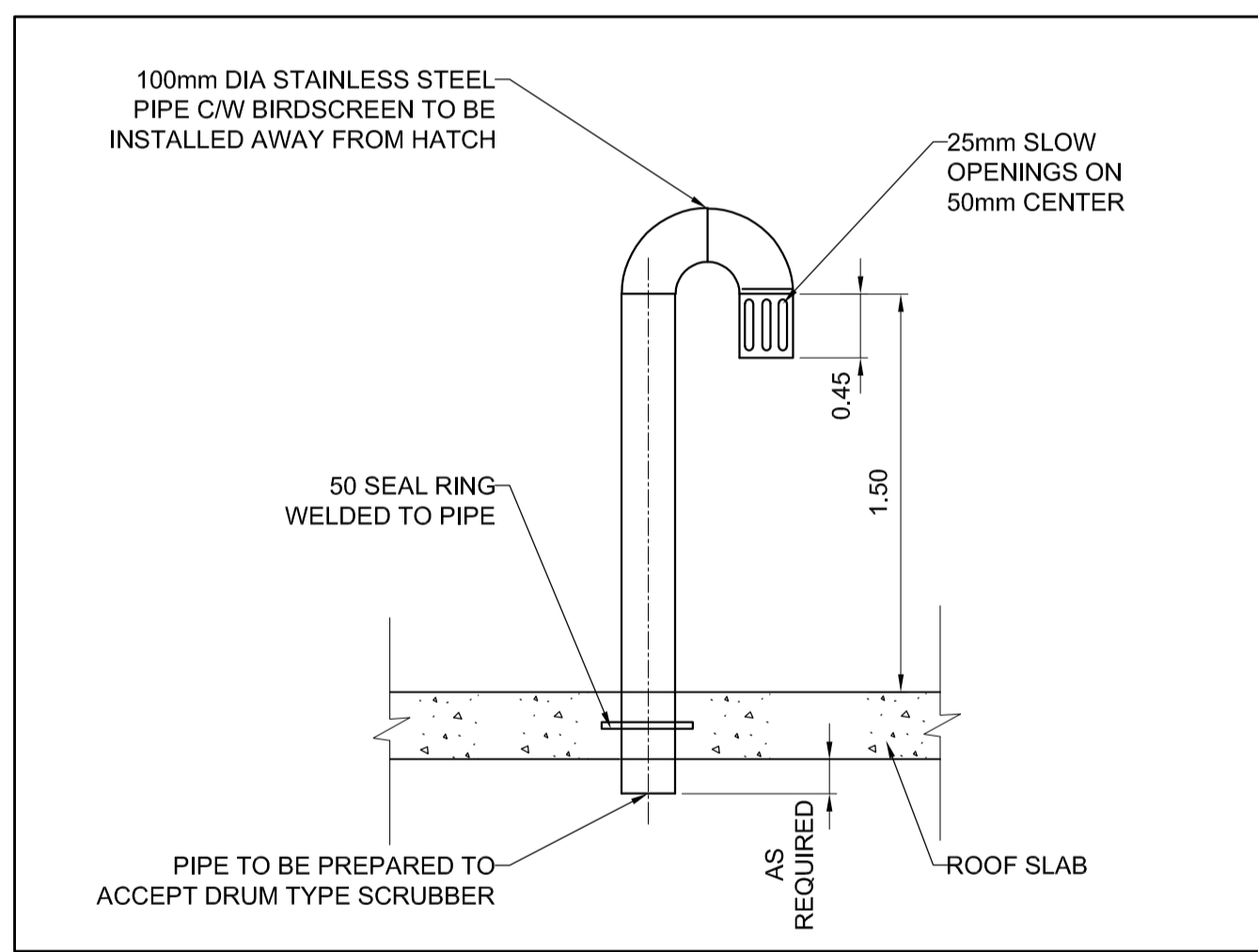

ROOF VENT DETAIL 1
 N.T.S.

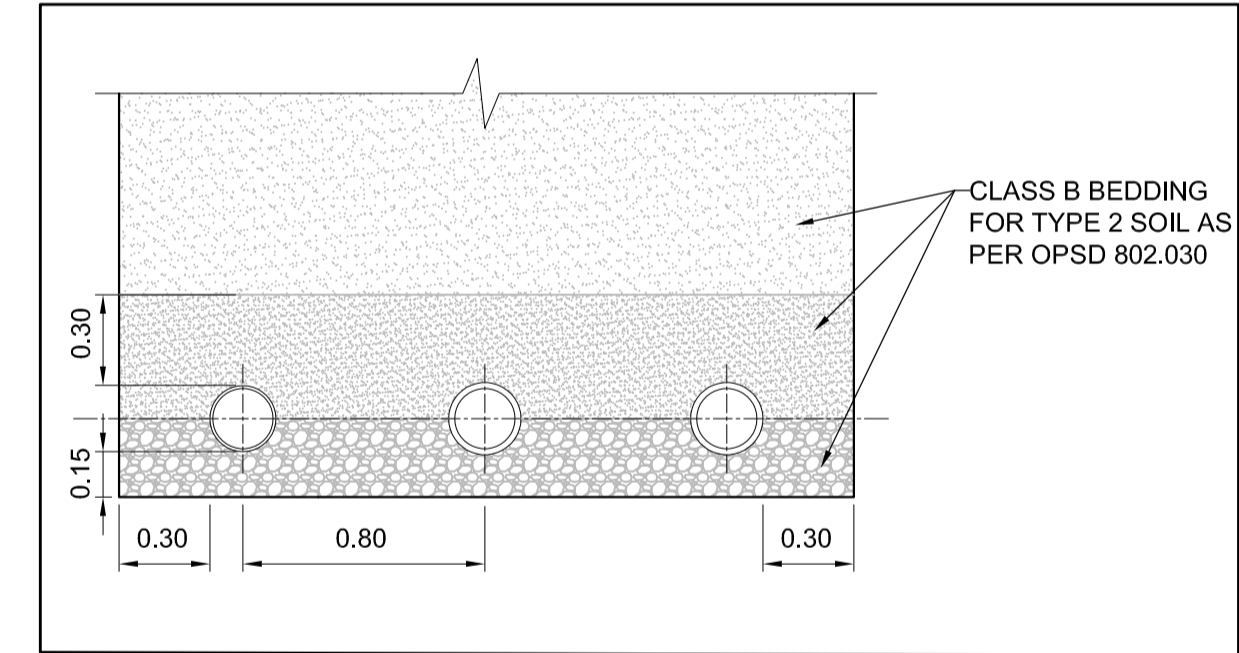

SECTION A
 1:25
 0001

FOR CLIENT REVIEW

THIS DRAWING WAS PREPARED FOR THE EXCLUSIVE USE OF WINDMILL DREAM ONTARIO LP ("ZBI") AND IS ISSUED PURSUANT TO THE ZBI WINDMILL DREAM PUMPING STATION AGREEMENT BETWEEN ZBI AND HATCH LTD. ("HATCH"). UNLESS OTHERWISE AGREED IN WRITING WITH ZBI OR SPECIFIED ON THIS DRAWING, HATCH DOES NOT ACCEPT AND DISCLAIMS ANY AND ALL LIABILITY OR RESPONSIBILITY ARISING FROM ANY USE OF OR RELIANCE ON THIS DRAWING BY ANY THIRD PARTY OR ANY MODIFICATION OR MISUSE OF THIS DRAWING BY ZBI. AND BY THIS DRAWING IS CONFIDENTIAL AND ALL INTELLECTUAL PROPERTY RIGHTS EMBODIED OR REFERENCED IN THIS DRAWING REMAIN THE PROPERTY OF HATCH.



ZIBI WINDMILL DREAM ONTARIO PUMP STATION
PROCESS MECHANICAL PLAN AND DETAILS

DRAFTSPERSON	J.BAJAGIC	NR	11-26-2021
DESIGNER	A.GIBBS	NR	11-26-2021
CHECKER	A.GIBBS/P.RUSCH		11-26-2021
DESIGN COORD.			
RESP. ENG.	P.RUSCH		11-26-2021
LEAD DISC. ENG.			
ENG. MANAGER			
PROJ. MANAGER	P.RUSCH		11-26-2021

B	FOR CLIENT REVIEW	J.B.	P.R.	12-03-2021
A	FOR CLIENT REVIEW	J.B.	P.R.	11-26-2021
No.	DESCRIPTION	BY	CHK'D	DATE

DRAWING APPROVAL STATUS: Client Review

SCALE: 1:50 OR AS NOTED
 DWG. No. H364639-0000-240-251-0001
 REV B

- GENERAL NOTES:**
- ALL ELEVATIONS SHOWN ARE IN METERS.
 - ALL PIPE SIZES AND DIMENSIONS ARE SHOWN MILLIMETERS.
 - REFER TO SITE PLAN DRAWING H364639-0000-220-251-0001 FOR POSITION AND ORIENTATION OF PUMPING STATION.
 - ALL PIPES TO HAVE FLEXIBLE JOINTS OUTSIDE OF THE PUMPING STATION. FORCEMAIN JOINT IS TO BE CONSTRUCTED WITH TIE RODS.
 - ALL CONCRETE SHOULD CONFORM TO CAN 3-A23.3-M77 (LATEST REVISION):
 - 28 DAY STRENGTH: 30MPa
 - SLUMP: 50mm
 - ENTRAINED AIR: 6%
 - CHAMFER ALL EXPOSED CONCRETE CONES/EDGES 20mm.
 - BACKFILL SHALL BE FREE-DRAINING MATERIAL (MTO GRANULAR "B" OR APPROVED EQUAL), MINIMUM 300mm THICKNESS, AND BE COMPACTED TO 100% STANDARD PROCTOR DENSITY.
 - BACKFILLING SHALL PROCEED UNIFORMLY ON ALL SIDES OF THE STRUCTURE (AS APPLICABLE), IN MAX. 0.2 METER LAYERS AND WITH MAX. 0.5 METER DIFFERENCE IN ELEVATION BETWEEN LEVELS BEHIND ANY SIDE TO BE BACKFILLED.
 - PROVIDE POLYETHYLENE SLIP MEMBRANE ALL AROUND STRUCTURE (TO PREVENT SOIL ADFREEZING) TO A MIN. DEPTH OF 2.0m BELOW FINISHED GRADE.
 - REFER TO SPECIFICATIONS FOR PUMP MODEL
 - ELECTRICAL PANEL TO BE HOUSED IN SEPARATE ENCLOSURE.
 - CONTRACTOR TO PROVIDE AND INSTALL SIX FROST STRAPS EQUALLY SPACED AROUND THE PERIMETER OF EACH CHAMBER, EXTENDING FROM BASE SLAB TO CAP. REFER TO OPSD 701.100 FOR FROST STRAP DIMENSION, MATERIALS AND INSTALLATION REQUIREMENTS.
 - BENCHING TO BE 30MPa CONCRETE AS PER NOTE 6. ALL BENCHING SHALL BE RE-ENFORCED AS PER CSA A23.3 FOR SLABS

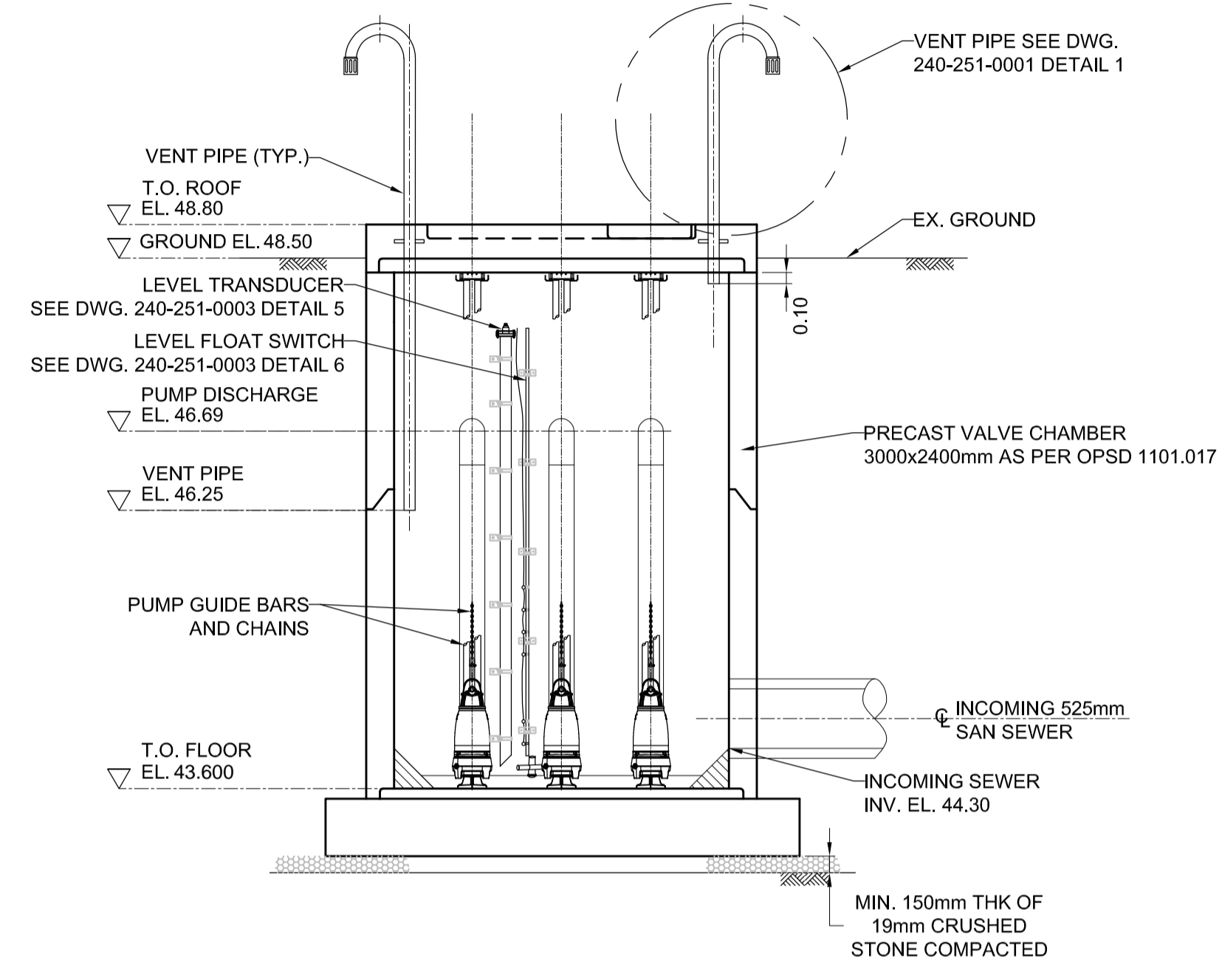

SECTION B
 SCALE 0001

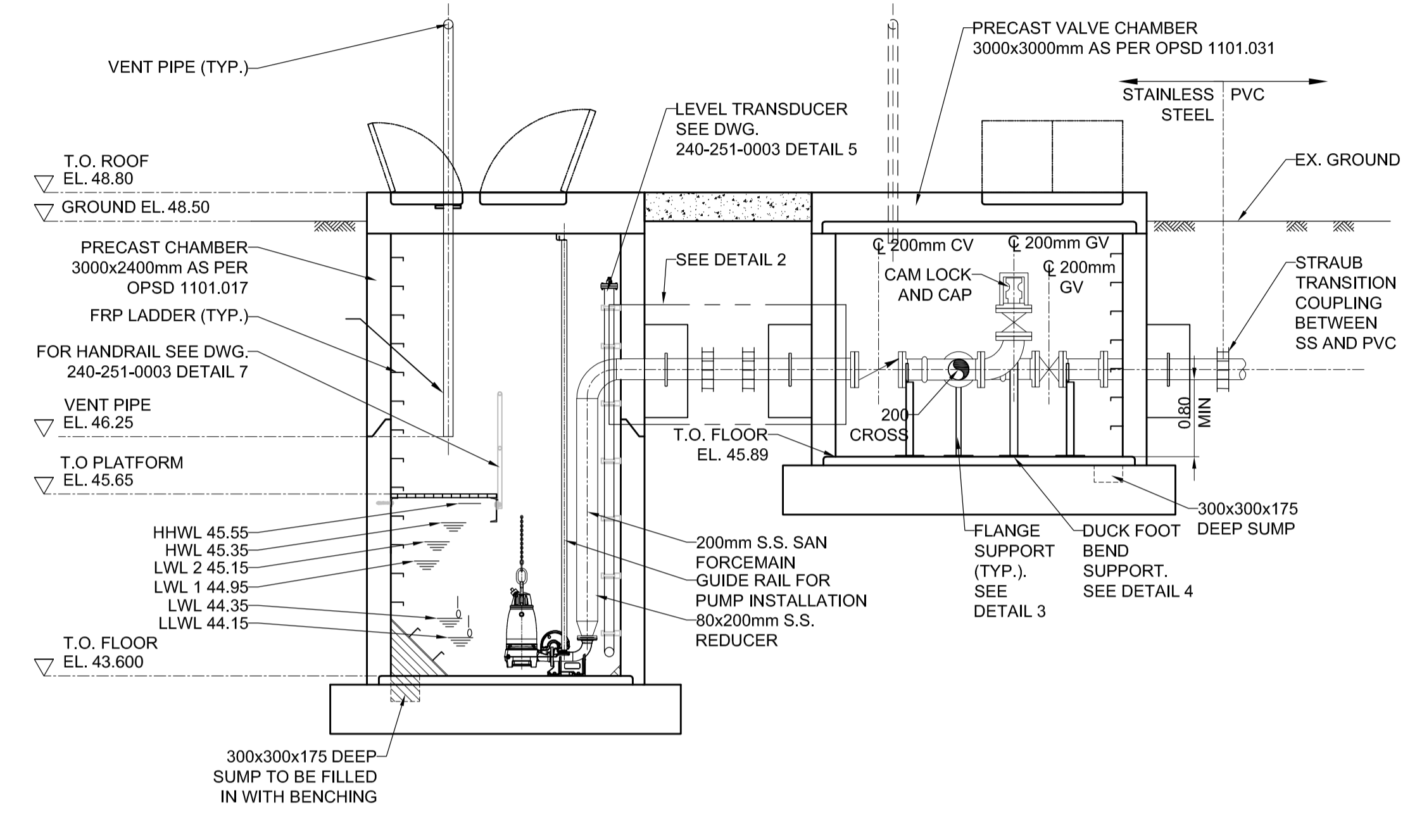

SECTION C
 SCALE 0001

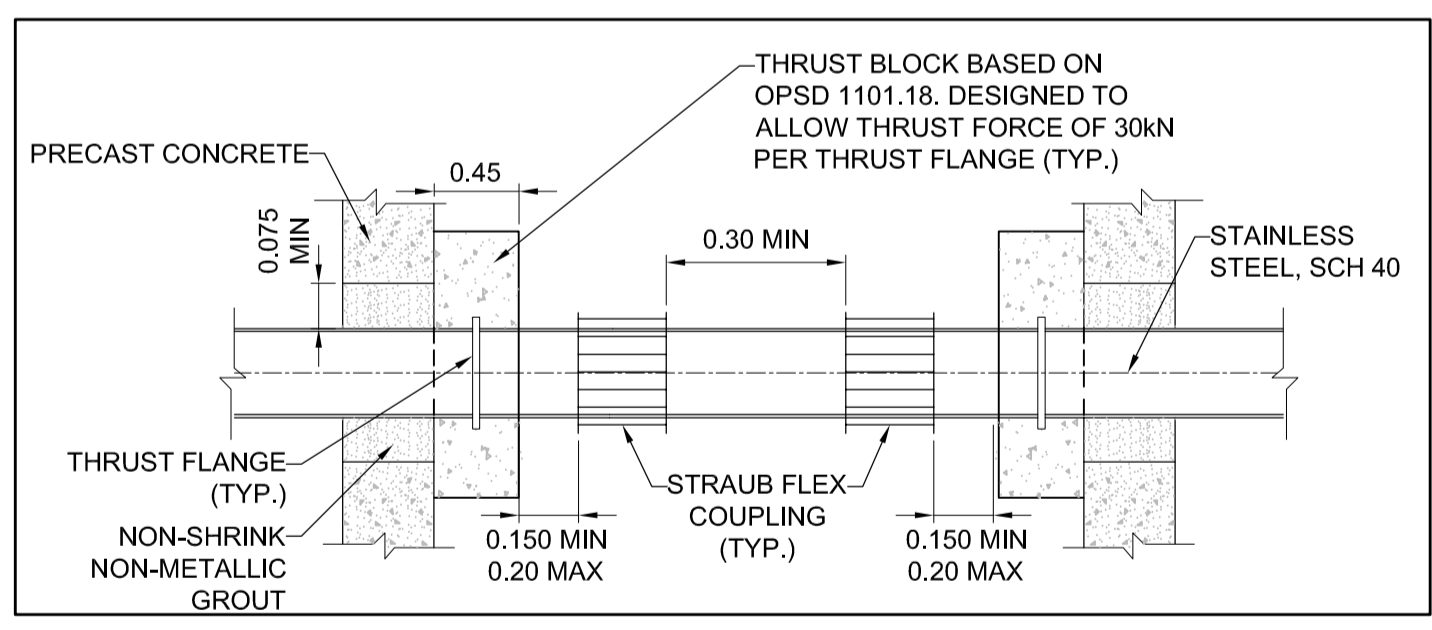

TYP. DETAIL OF PIPE ENTRY AND EXIT THROUGH PRECAST MH
 N.T.S.

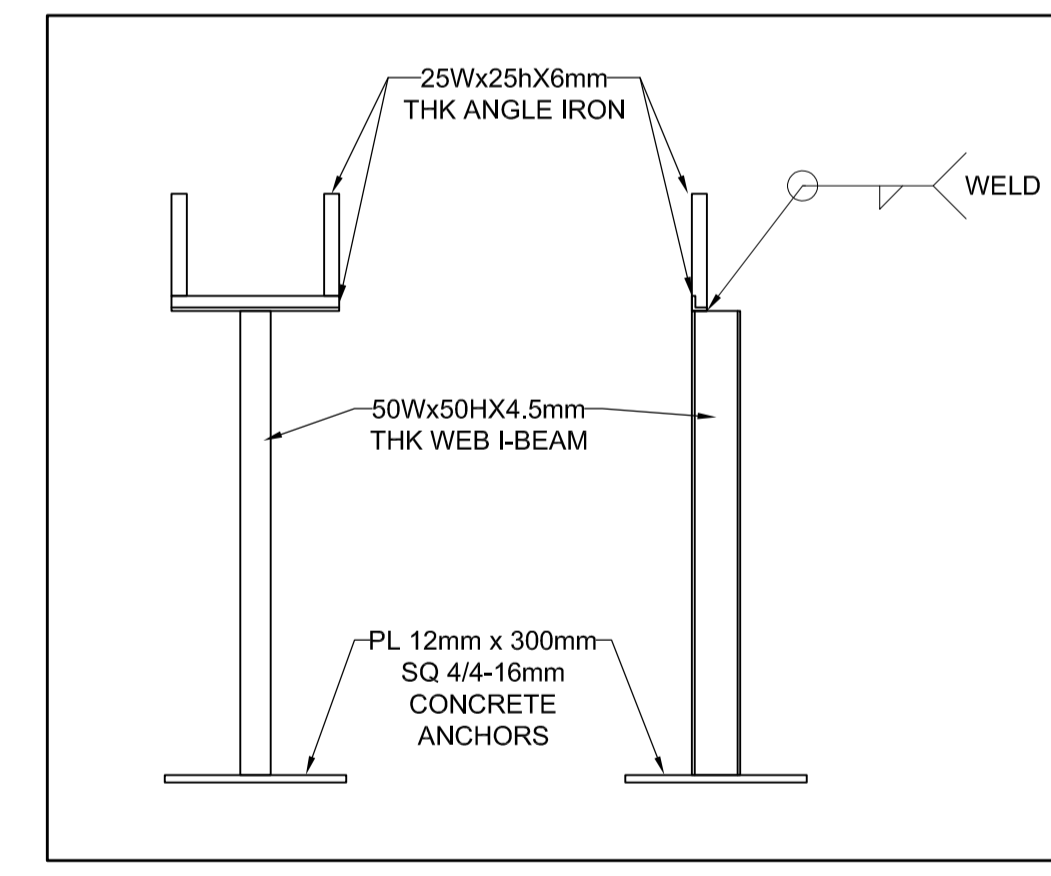

SUPPORT DETAIL 3
 N.T.S.

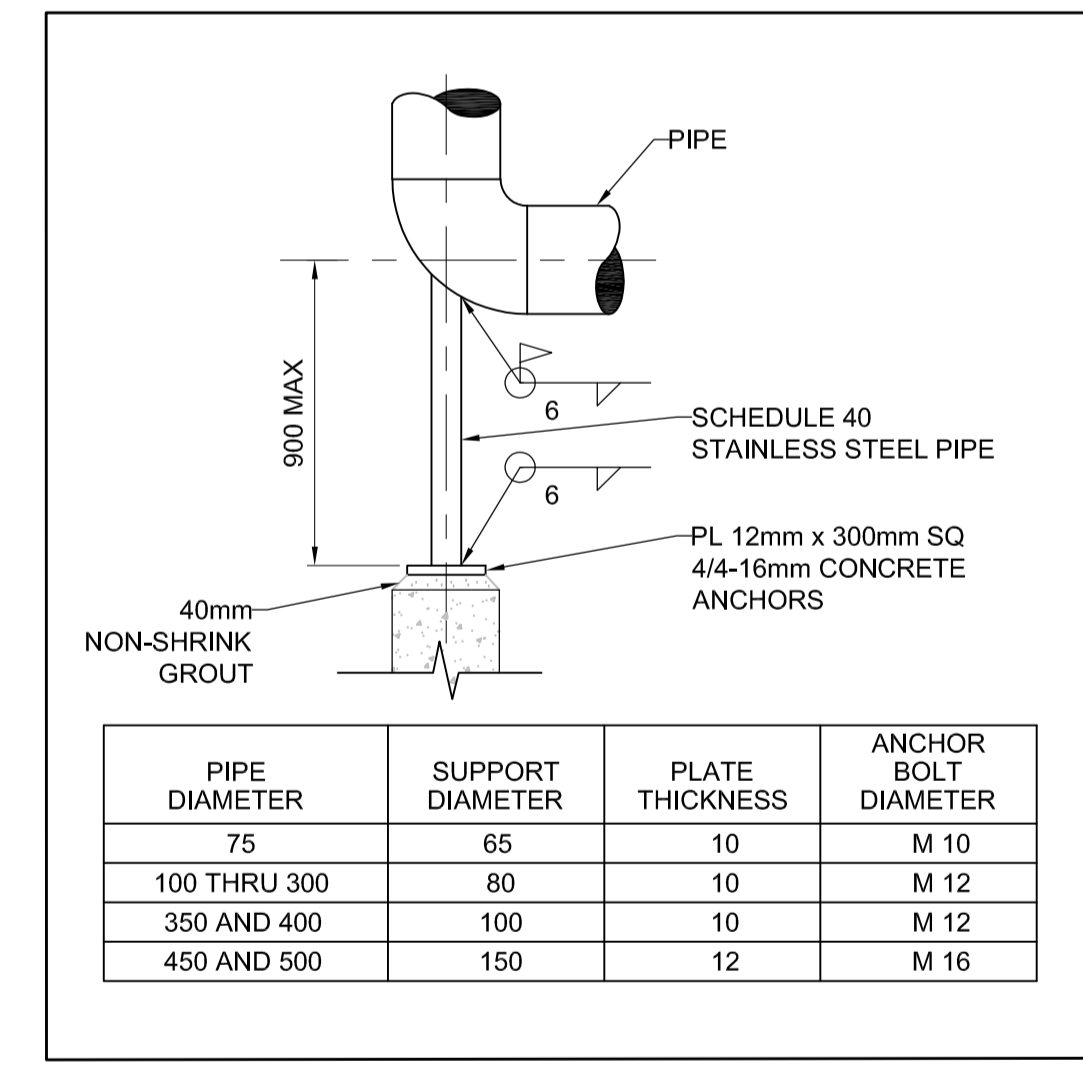

SUPPORT DETAIL 4
 N.T.S.

FOR CLIENT REVIEW

THIS DRAWING WAS PREPARED FOR THE EXCLUSIVE USE OF WINDMILL DREAM ONTARIO LP ("ZBI") AND IS ISSUED PURSUANT TO THE ZBI WINDMILL DREAM PUMPING STATION AGREEMENT BETWEEN ZBI AND HATCH LTD. ("HATCH"). UNLESS OTHERWISE AGREED IN WRITING WITH ZBI OR SPECIFIED ON THIS DRAWING, HATCH DOES NOT ACCEPT AND DISCLAIMS ANY AND ALL LIABILITY OR RESPONSIBILITY ARISING FROM ANY USE OF OR RELIANCE ON THIS DRAWING BY ANY THIRD PARTY OR ANY MODIFICATION OR MISUSE OF THIS DRAWING BY ZBI. AND (B) THIS DRAWING IS CONFIDENTIAL AND ALL INTELLECTUAL PROPERTY RIGHTS EMBODIED OR REFERENCED IN THIS DRAWING REMAIN THE PROPERTY OF HATCH.



ZIBI WINDMILL DREAM ONTARIO PUMP STATION
PROCESS MECHANICAL SECTION B, C AND DETAILS

DRAWING No.	DRAWING TITLE	REG. PROFESSIONAL	REVISIONS	BY	CHK'D	DATE	ROLE	NAME	SIGNATURE	DATE
C	FOR CLIENT REVIEW			J.B.	P.R.	03-14-2022	ENG. MANAGER			
B	FOR CLIENT REVIEW			J.B.	P.R.	12-03-2021	PROJ. MANAGER			
A	FOR CLIENT REVIEW			J.B.	P.R.	11-26-2021				

SCALE 1:50 OR AS NOTED
 DWG. No. H364639-0000-240-251-0002
 REV C

USER: BAJAGIC, JANKO
 DATE: 12/3/2021
 TIME: 10:59:39 AM
 FILE: C:\P\WORKING\HATCH-CPD-CANADA_CENTRAL\DM53442\H364639-0000-240-251-0002

A

B

C

D

E

F

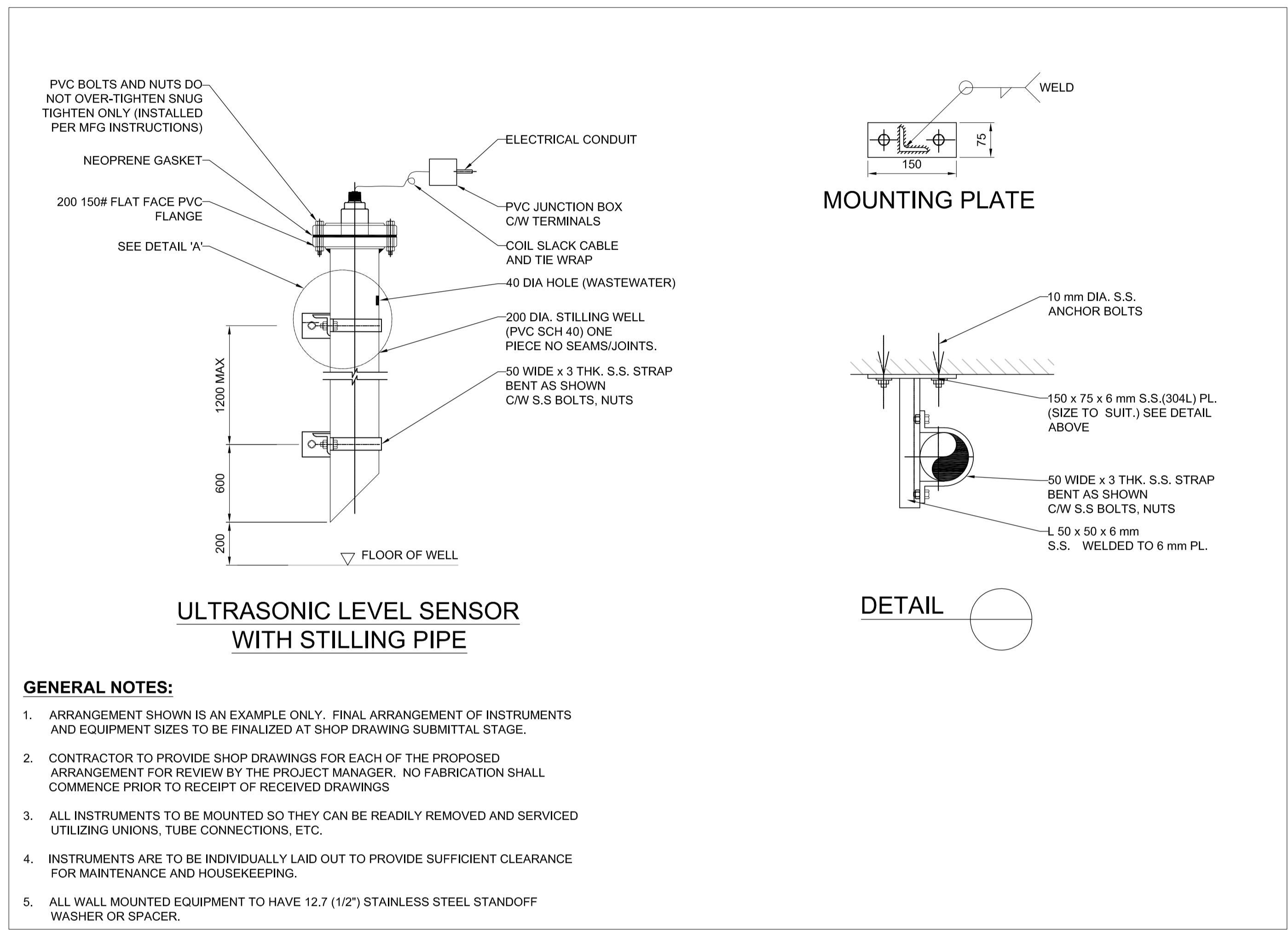

ULTRASONIC LEVEL SENSOR WITH STILLING PIPE

- GENERAL NOTES:**
- ARRANGEMENT SHOWN IS AN EXAMPLE ONLY. FINAL ARRANGEMENT OF INSTRUMENTS AND EQUIPMENT SIZES TO BE FINALIZED AT SHOP DRAWING SUBMITTAL STAGE.
 - CONTRACTOR TO PROVIDE SHOP DRAWINGS FOR EACH OF THE PROPOSED ARRANGEMENT FOR REVIEW BY THE PROJECT MANAGER. NO FABRICATION SHALL COMMENCE PRIOR TO RECEIPT OF RECEIVED DRAWINGS
 - ALL INSTRUMENTS TO BE MOUNTED SO THEY CAN BE READILY REMOVED AND SERVICED UTILIZING UNIONS, TUBE CONNECTIONS, ETC.
 - INSTRUMENTS ARE TO BE INDIVIDUALLY LAID OUT TO PROVIDE SUFFICIENT CLEARANCE FOR MAINTENANCE AND HOUSEKEEPING.
 - ALL WALL MOUNTED EQUIPMENT TO HAVE 12.7 (1/2") STAINLESS STEEL STANDOFF WASHER OR SPACER.

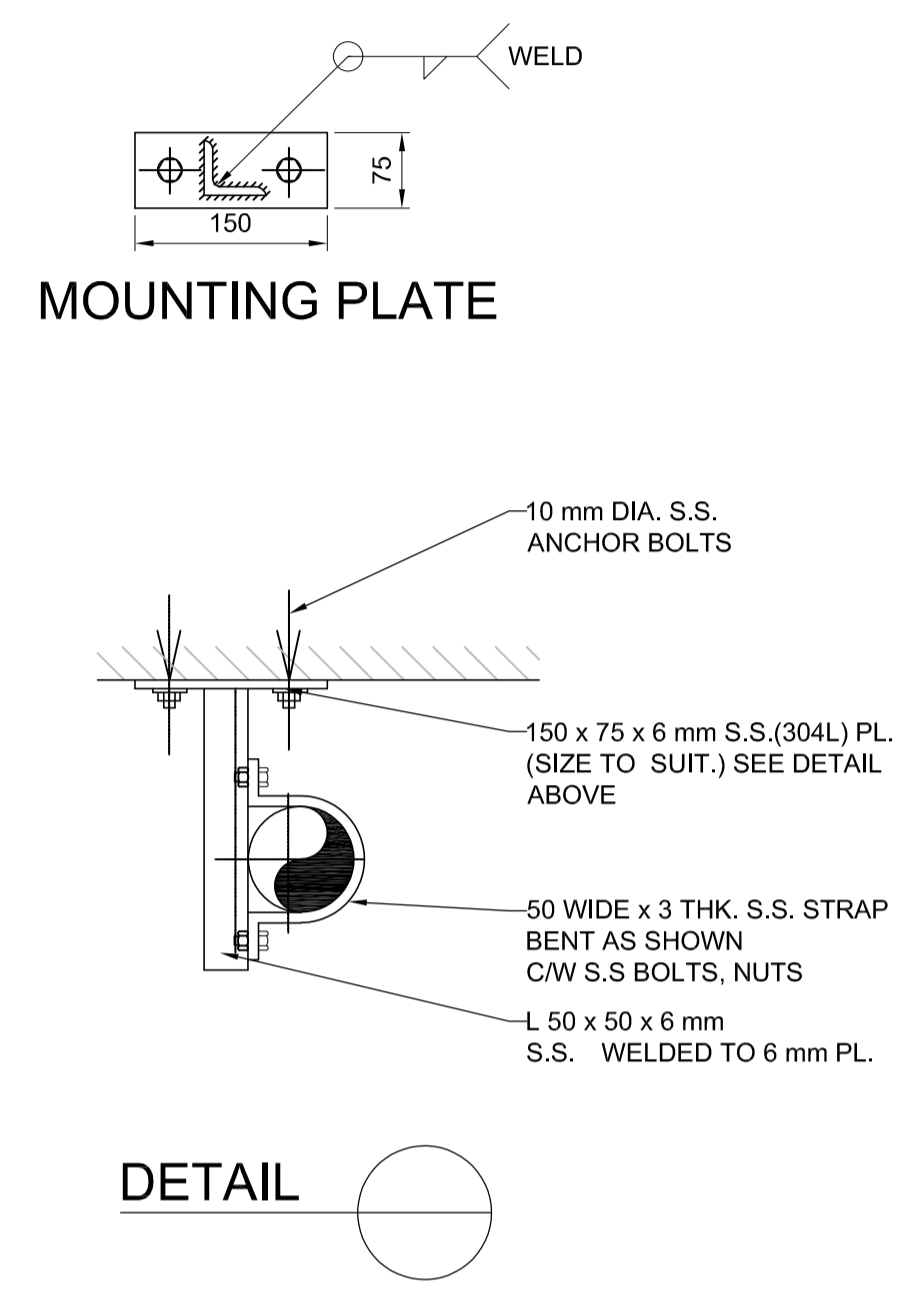

ULTRASONIC LEVEL SENSOR AND STILLING PIPE DETAIL

5

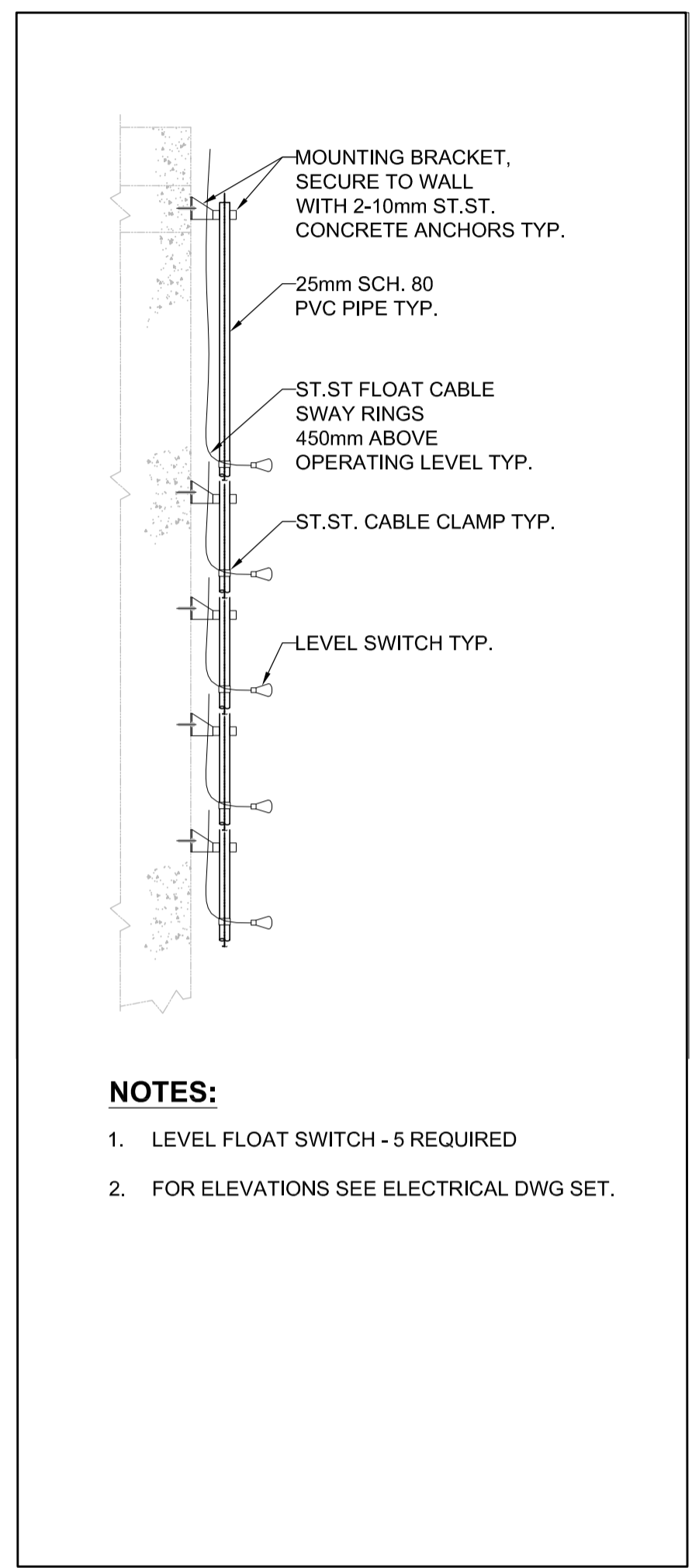

LEVEL FLOAT SWITCH DETAIL

6

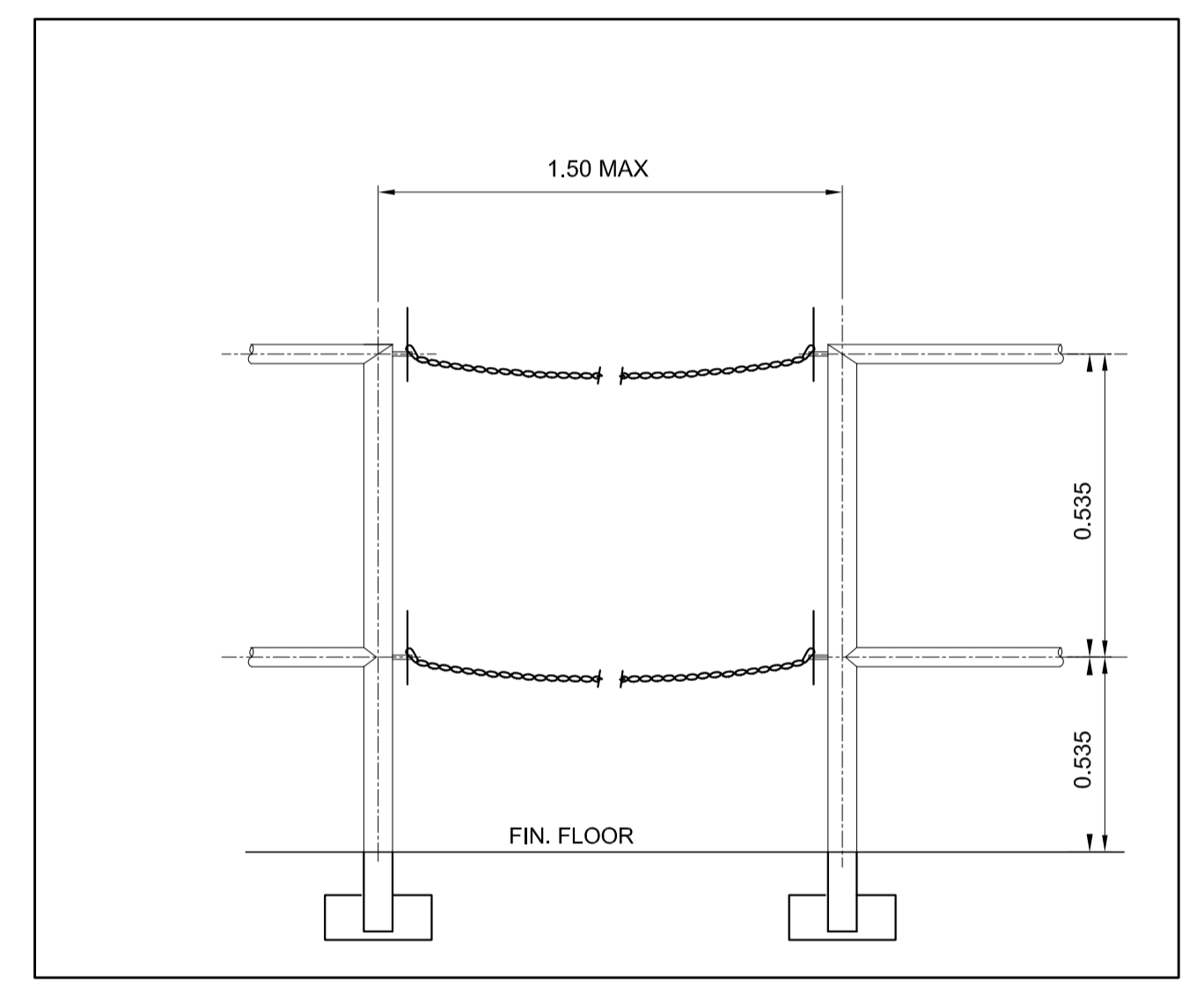

HANDRAIL DETAIL

7

FOR CLIENT REVIEW

THIS DRAWING WAS PREPARED FOR THE EXCLUSIVE USE OF WINDMILL DREAM ONTARIO LP ("ZBI") AND IS ISSUED PURSUANT TO THE ZBI WINDMILL DREAM PUMPING STATION AGREEMENT BETWEEN ZBI AND HATCH LTD. ("HATCH"), UNLESS OTHERWISE AGREED IN WRITING WITH ZBI OR SPECIFIED ON THIS DRAWING. (A) HATCH DOES NOT ACCEPT AND DISCLAIMS ANY AND ALL LIABILITY OR RESPONSIBILITY ARISING FROM ANY USE OF OR RELIANCE ON THIS DRAWING BY ANY THIRD PARTY OR ANY MODIFICATION OR MISUSE OF THIS DRAWING BY ZBI. AND (B) THIS DRAWING IS CONFIDENTIAL AND ALL INTELLECTUAL PROPERTY RIGHTS EMBODIED OR REFERENCED IN THIS DRAWING REMAIN THE PROPERTY OF HATCH.



ZIBI WINDMILL DREAM ONTARIO PUMP STATION
PROCESS MECHANICAL DETAILS

DRAWING No.	DRAWING TITLE	REG. PROFESSIONAL	DESCRIPTION	BY	CHK'D	DATE	ROLE	NAME	SIGNATURE	DATE
B	FOR CLIENT REVIEW			J.B.	P.R.	12-03-2021				
A	FOR CLIENT REVIEW			J.B.	P.R.	11-26-2021				

DRAFTSPERSON	J.BAJAGIC	NR	11-26-2021
DESIGNER	A.GIBBS	NR	11-26-2021
CHECKER	A.GIBBS/P.RUSCH		11-22-2021
DESIGN COORD.			-
RESP. ENG.	P.RUSCH		11-26-2021
LEAD DISC. ENG.			-
ENG. MANAGER			-
PROJ. MANAGER	P.RUSCH		11-26-2021

SCALE NTS OR AS NOTED
DWG. No. **H364639-0000-240-251-0003**
REV **B**

USERNAME: BAJAGIC_JANKO
 DATE: 12/31/2021 TIME: 9:57:33 AM
 FILE: C:\P\WORKING\HATCH\DPD-CANADA_CENTRAL\DM54421\H364639-000-240-251-0003

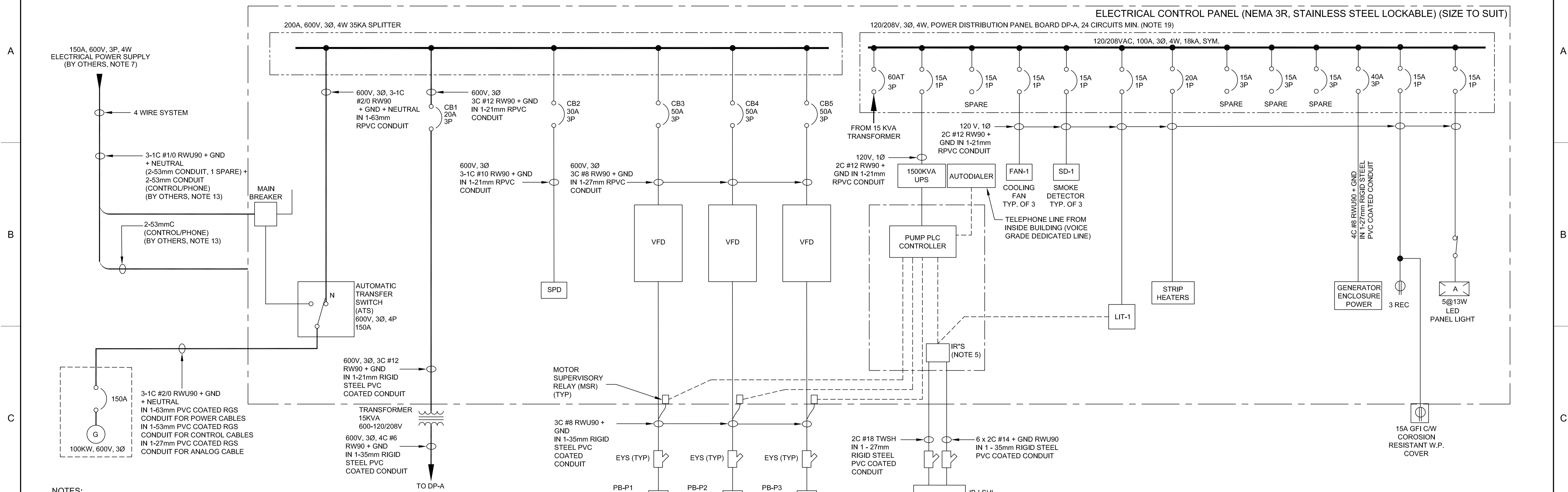

- NOTES:**
- PROVIDE COMPLETE GROUNDING SYSTEM AS PER THE OESC LATEST EDITION AND TO THE SATISFACTION OF THE ELECTRICAL AUTHORITY HAVING JURISDICTION.
 - ALL CONDUCTORS TO BE COPPER RW90 (RWU90) UNLESS OTHERWISE INDICATED.
 - PROVIDE POWER BOXES WITH TERMINAL BLOCKS SUITABLE FOR CLASSIFIED AREA.
 - PROVIDE NEMA 4X WITH TERMINAL BLOCKS FOR INTRINSICALLY SAFE CIRCUITS.
 - PROVIDE INTRINSICALLY SAFE RELAYS (IR'S) AS REQUIRED TO MEET CLASS I, ZONE 1 GROUP C & D CLASSIFICATION.
 - INSTALL POWER BOXES AND JB-LSHL AT PUMPS WELL LOCATION.
 - ELECTRICAL POWER SUPPLY AND OVERCURRENT PROTECTION DEVICE BY OTHERS. POWER SUPPLY UNDERGROUND CABLES AND DUCT BANK TO NEW OUTDOOR ELECTRICAL PANEL BY OTHERS COMPLETE WITH CABLE TERMINATIONS.
 - ALL WIRING METHODS IN CLASSIFIED AREAS ARE TO BE IN ACCORDANCE WITH APPLICABLE REQUIREMENTS OF SECTIONS 18 AND 22 OF THE LATEST EDITION OF THE ONTARIO ELECTRICAL SAFETY CODE.
 - ALL ELECTRICAL EQUIPMENT, PUMPS, AND MOTORS FOR USE IN CLASSIFIED AREAS MUST BE APPROVED FOR INSTALLATION IN SUCH CLASSIFIED AREA DIVISION INDICATED.
 - ALL SIDE MOUNTED EQUIPMENT TO BE RATED EEMAC 4X. LOCKABLE ENCLOSURE.
 - POWER BOXES AND JB-LSHL ON OUTSIDE OF PUMP WELL. ALL POWER AND JUNCTION BOXES TO BE EXPLOSION PROOF RATED.
 - OUTDOOR CONTROL PANEL NEMA 3R, COMPLETE WITH LOCKABLE DOOR HANDLE, DOOR SWITCH TO DETECT ILLEGAL ENTRY, AND SMOKE DETECTOR.
 - ELECTRICAL POWER SUPPLY UNDERGROUND DUCT BANK TO BE PROVIDED BY OTHERS. UTILITY POWER CABLES, COMMUNICATION AND TELEPHONE WIRING REQUIRED FROM THE SERVICE TO THE PUMP STATION CONTROL PANEL SHALL BE PROVIDED BY OTHERS.
 - THE PANEL LAYOUT SHOWN IS INTENDED TO RELAY THE MINIMUM SCOPE OF WORK AND HARDWARE REQUIRED. ACTUAL LAYOUT MAY VARY TO SUIT FIELD CONDITIONS. THE CONTRACTOR TO SUBMIT COMPLETE AND DETAILED PANEL LAYOUT SHOP DRAWING FOR REVIEW. PANEL DOOR TO BE LOCKABLE.
 - ALL EQUIPMENT WITHIN THE HAZARDOUS LOCATION SHALL BE APPROVED FOR THAT LOCATION.
 - THE CONTRACTOR IS RESPONSIBLE FOR MOUNTING OF ALL NEW POWER AND CONTROL PANELS, TRANSFORMER, JUNCTION AND POWER BOXES COMPLETE WITH REQUIRED CONCRETE PADS AND HARDWARE.
 - WIRE GAUGE MAY CHANGE PENDING RECOMMENDED BREAKER SETTING BY PUMP MANUFACTURER. MINIMUM ACCEPTED SIZE IS #8 AWG FOR POWER CABLES, #14 FOR CONTROL CABLES.
 - AUTOMATIC TRANSFER SWITCH TO BE INSTALLED INSIDE ELECTRICAL ENCLOSURE.
 - POWER DISTRIBUTION PANELBOARD BY EATON POW-R-LINE C SERIES OR APPROVED EQUAL.

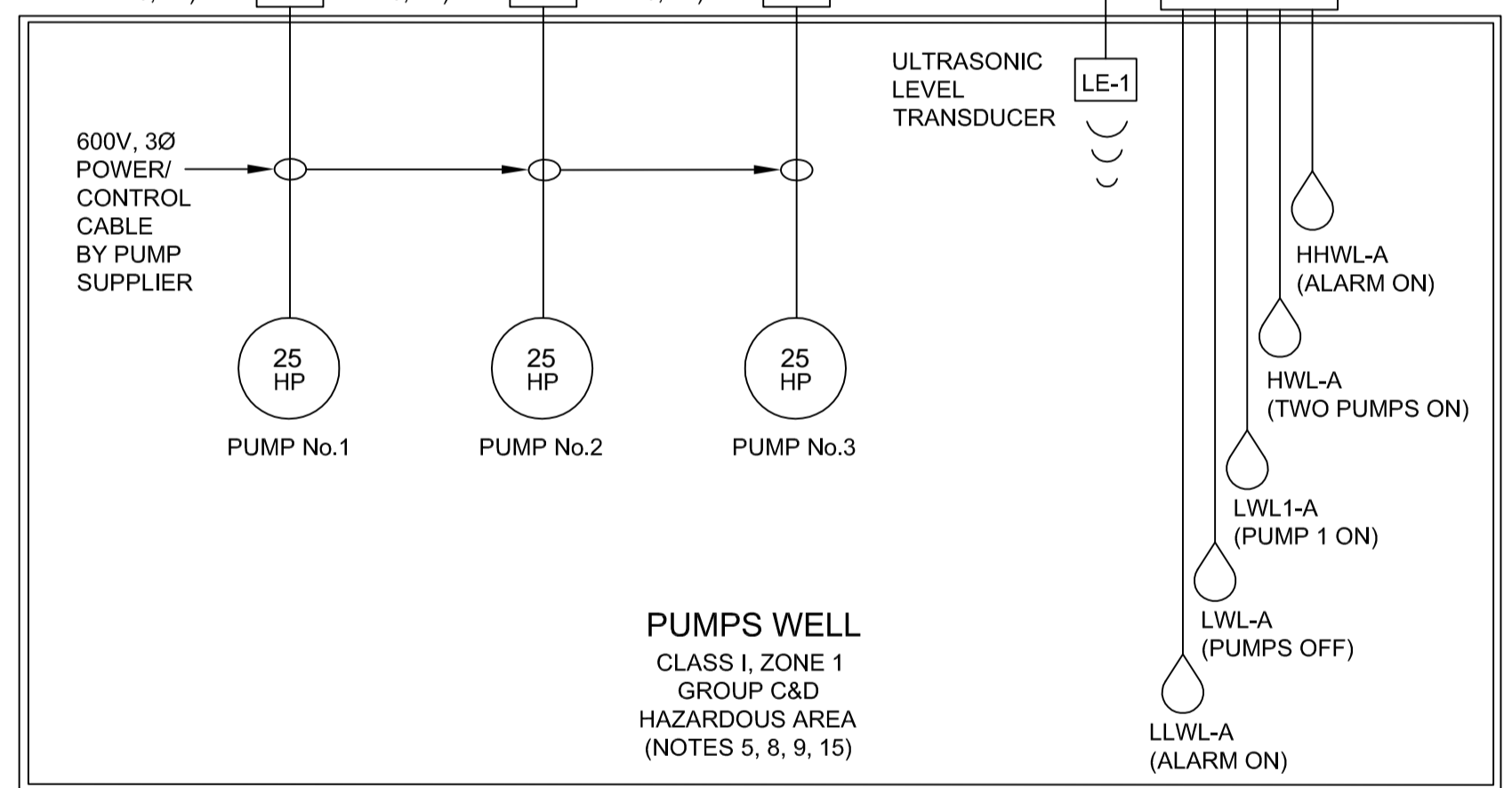

Ultrasonic			Float		
NOTES	Name	Level (m)	Level (m)	Name	NOTES
	HHWL	45.55	45.65	HHWL-A	ALARM
ALARM LEVEL	HHWL	45.55	45.45	HWL-A	PUMP 2 ON
BOTH PUMPS FULL SPEED	HWL	45.35			
PUMP 2 ON	LWL2	45.15			
PUMP 1 ON PUMP 2 OFF	LWL1	44.95	45.05	LWL1-A	PUMP 1 ON PUMP 2 OFF
PUMP 1 OFF	LWL	44.35			
ALARM	LLWL	44.15	44.25	LWL-A	PUMP 1 OFF
			44.05	LLWL-A	ALARM

SINGLE LINE DIAGRAM

FOR CLIENT REVIEW

THIS DRAWING WAS PREPARED FOR THE EXCLUSIVE USE OF WINDMILL DREAM ONTARIO LP ("ZIBI") AND IS ISSUED PURSUANT TO THE ZIBI WINDMILL DREAM PUMPING STATION AGREEMENT BETWEEN ZIBI AND HATCH LTD. ("HATCH"). UNLESS OTHERWISE AGREED IN WRITING WITH ZIBI OR SPECIFIED ON THIS DRAWING, HATCH DOES NOT ACCEPT AND DISCLAIMS ANY AND ALL LIABILITY OR RESPONSIBILITY ARISING FROM ANY USE OF OR RELIANCE ON THIS DRAWING BY ANY THIRD PARTY OR ANY MODIFICATION OR MISUSE OF THIS DRAWING BY ZIBI. AND (B) THIS DRAWING IS CONFIDENTIAL AND ALL INTELLECTUAL PROPERTY RIGHTS EMBODIED OR REFERENCED IN THIS DRAWING REMAIN THE PROPERTY OF HATCH.



ZIBI WINDMILL DREAM ONTARIO PUMPING STATION
ELECTRICAL SINGLE LINE DIAGRAM

DRAFTSPERSON	L.BO	NR	12-03-2021
DESIGNER	G.NING	NR	12-03-2021
CHECKER	G.NING		12-03-2021
DESIGN COORD.			-
RESP. ENG.	G.NING		12-03-2021
LEAD DISC. ENG.			-
ENG. MANAGER			-
PROJ. MANAGER	P.RUSCH		12-03-2021

B	FOR CLIENT REVIEW	L.B.	G.N.	03-14-2022
A	FOR CLIENT REVIEW	L.B.	G.N.	12-03-2021
No.	DESCRIPTION	BY	CHK'D	DATE
	REG. PROFESSIONAL			

DRAWING APPROVAL STATUS: Client Review

SCALE: NTS OR AS NOTED
DWG. No. **H364639-0000-260-262-0001**
REV **B**

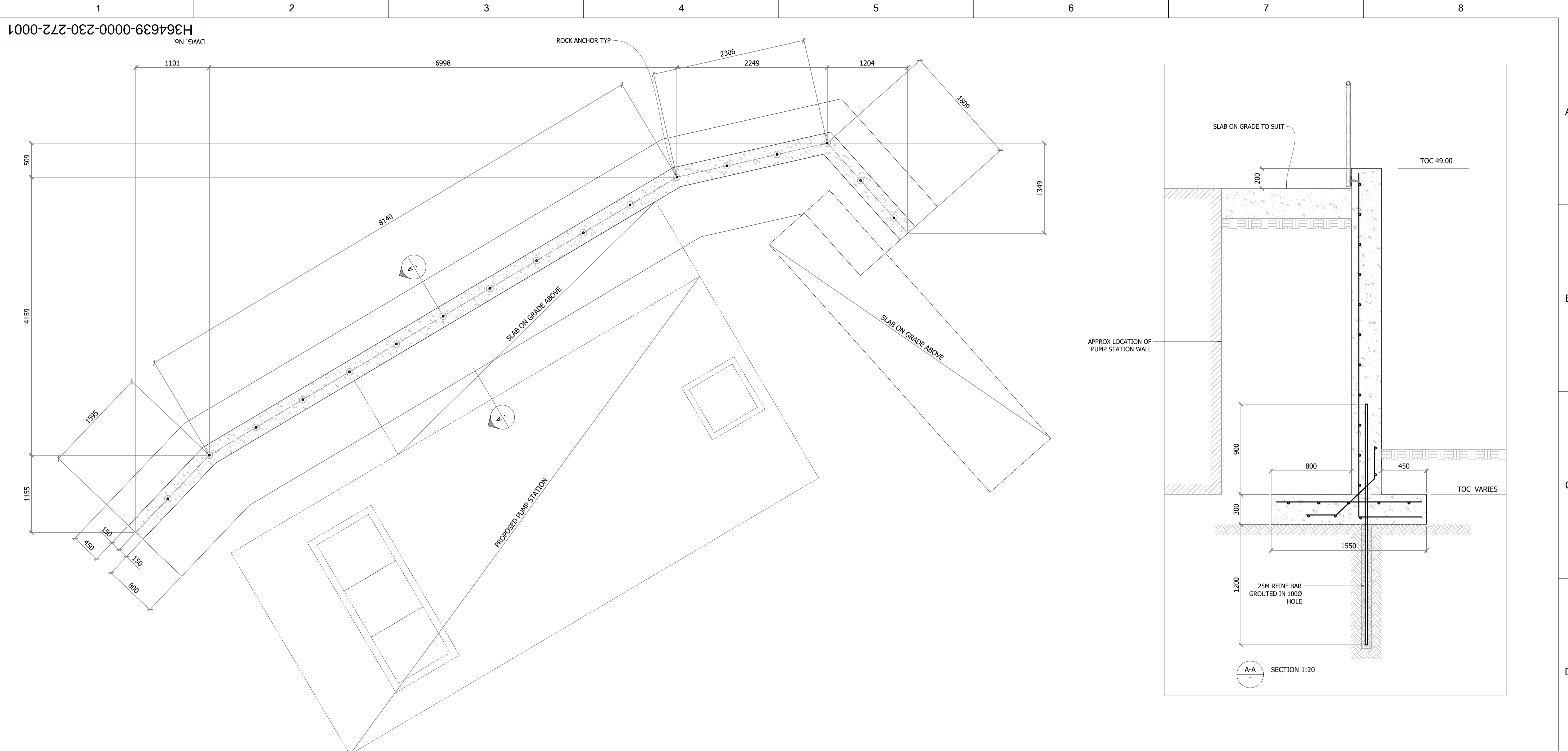

PLAN AT TOP OF RETAINING WALL FOOTING

FOR CLIENT REVIEW

THIS DRAWING WAS PREPARED FOR THE EXCLUSIVE USE OF WINDMILL DREAM ONTARIO LP ("ZIBI") AND IS ISSUED PURSUANT TO THE ZIBI WINDMILL DREAM PUMPING STATION AGREEMENT BETWEEN ZIBI AND HATCH LTD. ("HATCH"). UNLESS OTHERWISE AGREED IN WRITING WITH ZIBI OR SPECIFIED ON THIS DRAWING, HATCH DOES NOT ACCEPT AND DISCLAIMS ANY AND ALL LIABILITY OR RESPONSIBILITY ARISING FROM ANY USE OF OR RELIANCE ON THIS DRAWING BY ANY THIRD PARTY OR ANY MODIFICATION OR MISUSE OF THIS DRAWING BY ZIBI AND (B) THIS DRAWING IS CONFIDENTIAL AND ALL INTELLECTUAL PROPERTY RIGHTS EMBODIED OR REFERENCED IN THIS DRAWING REMAIN THE PROPERTY OF HATCH.

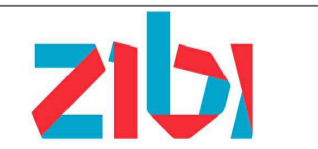

ZIBI WINDMILL DREAM ONTARIO PUMPING STATION
STRUCTURAL RETAINING WALL DETAILS

DRAFTSPERSON	ARP	NR	MAR 2022
DESIGNER	JPM	NR	MAR 2022
CHECKER	JPM		MAR 2022
DESIGN COORD.	-		PR
RESP. ENG.	-		-
LEAD DISC. ENG.	-		-
ENG. MANAGER	-		-
PROJ. MANAGER	-		-

DRAWING No.	DRAWING TITLE	REG. PROFESSIONAL
1	REFERENCE DRAWINGS	
2		
3		
4		
5		
6		
7		
8		

No.	DESCRIPTION	A.P.	J.M.	03-14-2022
A	FOR CLIENT REVIEW			

DRAWING APPROVAL STATUS: -

SCALE VARIES OR AS NOTED
 DWG. No. H364639-0000-230-272-0001
 REV A

FILE: C:\SECANT\PROJECTS\C1 - HATCH\YEAR 2021\A - ZIBI\RETAINING WALL
 USERNAME: JEFFREY.P. MARSH
 DATE: 2022-03-11 TIME: 4:59:24 PM
 SHEET SIZE: A1

Appendix 2 System Curve and Calculations

Pump/System Performance Curves for Proposed Pumps

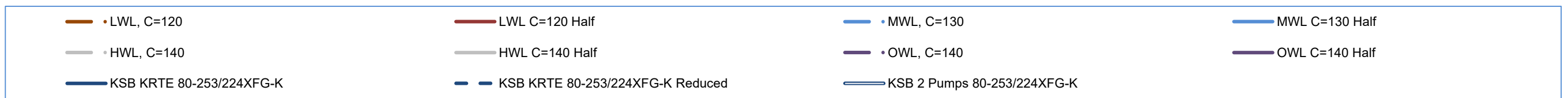
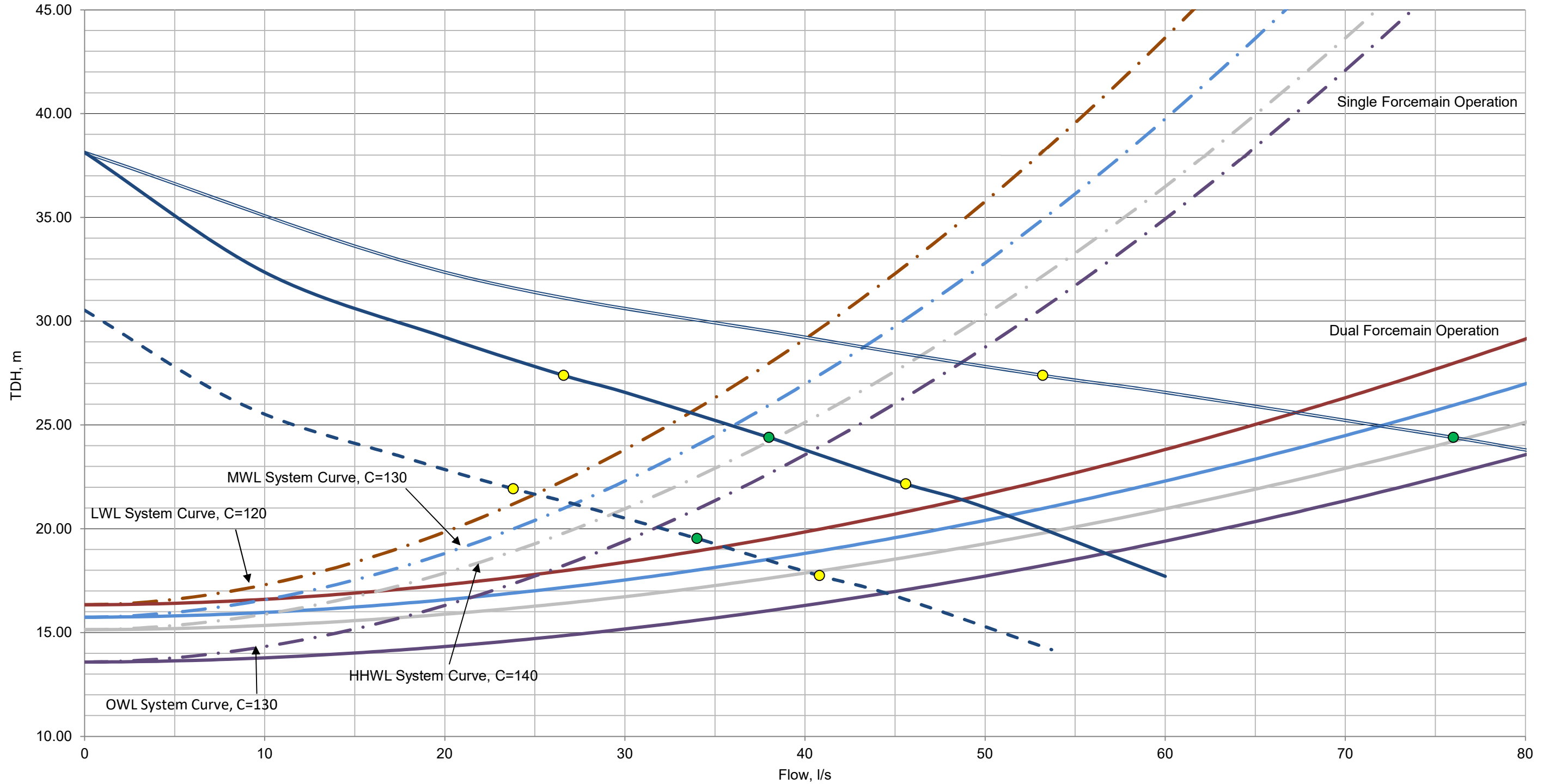

Windmill Dream Hydraulic Calculations

Incoming Sewer Hydraulics				Design Notes
Upstream Invert at Maintenance Hole SAN401A	46.290	m		Invert on drawing "Zaida Eddy Private" (717_Block 211_PP1_Asbuilt.pdf) Dimensioned off of "Zaida Eddy Private" (717_Block 211_PP1_Asbuilt.pdf) Continuing slope from MH SAN100A to MH SAN401A
Extra Drop within Maintenance Hole SAN401A	0.81	m		
Exit Invert at Maintenance Hole SAN401A	45.480	m		
Storage Pipe Length	51.67	m		
Storage Pipe Slope	0.23%			
Entrance Invert at Maintenance Hole SAN402A	45.360	m		
Approach Pipe				Calculated to ensure suitable hydraulic jump in approach pipe. Assuming a 525 nominal diameter pipe.
Drop within Maintenance Hole SAN402A	0.700	m		
Exit Invert at Maintenance Hole SAN402A	44.660	m		
Approach Pipe Length	14.1	m		
Approach Pipe Slope	3.90%			
Approach Pipe Diameter	0.533	m		
Invert at Pumping Station	44.110	m		
Minimum Active Volume of Wet Well				Minimum specified by all manufacturers Designing for station to run with one pump for extended periods
Flow to PS (half station capacity = max starts)	0.045	m ³ /s		
Maximum Flow Rate Per Pump	0.035	m ³ /s		
Number of Pump Starts per Hour (combined for all pumps)	8			
Number of Pumps in Operation	1			
Min. Volume of Wetwell+Approach Pipe (between LWL and LWL1)	3.94	m ³		
Wet Well Dimensions				Excluding benching and pumps. Assuming 90% surface area in wet well remaining. Calculated Value Set Value
Width of Wet Well	2.44	m		
Length of Wet Well	3.05	m		
Wet Well Area	7.43	m ²		
Effective Surface Area	6.69	m ²		
Minimum Operational Depth (LWL to LWL1)	0.59	m		
Minimum Operational Depth (LWL to LWL1)	0.60	m		
Water Levels				Aligning to just below top of the low flow channel in storage pipe. Float Level. Set as 200mm below alarm. Pump speeds increase to full speed. Pump 2 Start Pump 1 Start Per Approach pipe calculator, capacity at 0.45 d/D = 56.6l/s. Adequate. Since active volume is greater than minimum volume pumps will not cycle too frequently.
HHWL (Alarm)	45.55	m	Top of Benching 45.56	
HWL (Pumps full speed)	45.35	m		
LWL2 (Pump 2 on)	45.15	m		
LWL1 (Pump 1 on)	44.95	m		
LWL (Pumps off)	44.35	m		
LLWL (Alarm)	44.15	m		
Approach Pipe Fill Ratio at LWL	0.45			
Total Active Wet Well Volume (excluding pump motor)	4.01	m ³		
Wet Well Floor				
Low-Low Water Level	44.15	m		
Minimum Water Level above Wet Well Floor	0.445	m		
Additional Safety Factor	0.11	m		
Wet Well Floor	43.60	m		
Top of volute	44.04	m		
Storage				Invert on drawing "Zaida Eddy Private" (717_Block 211_PP1_Asbuilt.pdf) Assuming a pre-fabricated maintenance hole Using full storage capacity since motors to not extend significantly into volume between HWL and OWL Confirmed 1500mm RCP can be joined to 2400mm MH as per Decast literature. Assuming storage upstream of SAN401A is insignificant. Refer to Schematic Drawing. Available volume prior to overflow Including Approach Pipe volume unoccupied during operation Including volume in Wet Well above HWL
Minimum Overflow Time	30	minutes		
Maximum Flow to Pumping Station	0.045	m ³ /s		
Storage Volume Required between HWL and Overflow	81.0	m ³		
Overflow Invert	47.109	m		
Wet Well Dimensions				
Width of Wet Well	2.44	m		
Length of Wet Well	3.05	m		
Wet Well Area	7.43	m ²		
Storage Volume in Wet Well above HWL	11.6	m ³		
SAN402A Maintenance Hole				
SAN402A Maintenance Hole Diameter	3.05	m		
SAN402A Maintenance Hole Storage above High Water Alarm Level	11.4	m ³		
SAN401A Maintenance Hole				
SAN401A Maintenance Hole Diameter	2.44	m		
SAN401A Maintenance Hole Storage above HWL	7.3	m ³		
Storage Pipe (SAN401A - SAN402A)				
Diameter	1.52	m		
Effective Storage (full area less benching and low flow channel)	1.55	m ³ /m		
Available Storage Volume	80.1	m ³		
Storage in Storage Pipe	80.1	m ³		
Storage in Maintenance Holes (Including Wet Well)	30.2	m ³		
Total Volume below OWL	110.3	m ³		
Storage Time (incoming flow of 45 L/s)	40.9	minutes		
Storage Time (incoming flow of 35 L/s)	52.5	minutes		
NPSH Requirements				KSB 80-253/224XFG-K
NPSH _r	KSB - Pump			
	LWL	LWL 1	Overflow	
Flow Rate (L/s)	22.5	30	34	
NPSH _r Required (Maximum), (m)	3.3	4.1	4.6	
Target/Initial Safety Factor	1.7	1.7	1.7	
NPSH Required @ Flow incl. FS (m)	5.61	6.97	7.82	
NPSH_a Determination				Height above sea level at low water level Standard atmospheric pressure at site elevation. From water property table. A-8 in Sanks. From Sanks Using Equation 10-25 in Pumping Station Design (Jones): $NPSH_a = H_{bar} + h_s - h_{vap} - h_{fs} - \sum h_m - h_{vel} - FS$
Pump Station Elevation	44.15	m		
Atmospheric Pressure	10.33	m	101.3 kPa	
h_{vap} Vapour Pressure at 30°C	0.43	m		
h_{vol} partial pressure due to organics	0.6	m		
NPSH _a (site specific subtotal)	9.30	m		
NPSH Comparison				Values selected to represent the potential range of flows. Losses are already factored into suction since hardware is integrated.
	LWL	LWL 1	OWL	
Pump Flow Rate, Q	22.5	30	34	
Total Suction Losses	0.00	0.00	0.00	
NPSH _a at liquid Surface	9.30	9.30	9.30	
Correction above minimum liquid level of pump	0.31	0.91	3.07	
Adjusted NPSH _a (relative to minimum liquid level of pump)	9.61	10.21	12.37	
NPSH Required @ Flow including a factor of safety	5.61	6.97	7.82	
Final NPSH Safety Factor	2.91	2.49	2.69	

Appendix 3 KSB Pump Curve

Data sheet



Customer item no.:35L/s @ 25m
Communication dated: 11/03/2022
Doc. no.: Zibi Pump
Quantity: 1

Number: ES 8001749776
Item no.: 200
Date: 11/03/2022
Page: 1 / 7

KRTE 80-253/224XFG-K

Version no.: 1

Operating data

Requested flow rate	35.000 l/s	Actual flow rate	35.253 l/s
Requested developed head	25.00 m	Actual developed head	25.15 m
Pumped medium	Wastewater, municipal untreated	Efficiency	75.4 %
Pumped medium details	Not containing chemical and mechanical substances which affect the materials	Power absorbed	11.88 kW
Ambient air temperature	20.0 °C	Pump speed of rotation	1777 rpm
Fluid temperature	20.0 °C	Shutoff head	38.14 m
Fluid density	1030 kg/m ³	Max. power on curve	16.61 kW
Fluid viscosity	1.00 mm ² /s	Design	Single system 1 x 100 %
Static head	15.00 m	Performance test	Yes
Ex-Request acc.to Atex	II T3		

Design

Design	Close-coupled submersible	Calculated temperature increase at shaft seal	K
Orientation	Vertical	Impeller type	Single vane, radial flow (E)
Suction flange pump drilled according to(DN1)	unmachined	Wear ring	Casing wear ring
Discharge flange pump drilled according to(DN2)	EN 1092-2 / DN 80 / PN 10	Impeller diameter	255.0 mm
Shaft seal	2 mech. seals in tandem arrangement with oil reservoir	Free passage size	76 mm
Shaft seal manufacturer	KSB	Direction of rotation from drive	Clockwise
Type	4STK	Ex protection	Explosion protection to CSA Class1, Div1, Gr.C, D T3
Material code	SIC/SIC/NBR	Color	Ultramarine blue (RAL 5002) KSB-blue

Driver, accessories

Driver type	Electric motor	Motor service factor	1.15
Model (make)	KSB	Temperature sensor	PTC resistor
Motor const. type	KSB Sub. motor	Motor winding	575 V
Operating mode	S1, non submerged operation	Number of poles	4
NEMA code letter	H	Starting mode	Direct-on-line starting
Frequency	60 Hz	Connection mode	Delta
Rated voltage	575 V	Motor cooling method	closed-circuit jacket cooling
Rated power P2	18.64 kW	Motor cooling jacket	With
Available reserve	56.87 %	Motor version	X
Rated current	24.5 A	Cable design	Rubber hose
Starting current ratio	6.7	Cable entry	Sealed along entire length
Insulation class	H according IEC 34-1	Power cable	AWG 11-7+15-5
Type of protection	XP/II/1/CD	Number of power cables	1
Motor enclosure	IP68	Moisture sensor	With
Cos phi at 4/4 load	0.85	Cable length	10.00 m
Motor efficiency at 4/4 load	89.9 %		

Data sheet



Customer item no.: 35L/s @ 25m
Communication dated: 11/03/2022
Doc. no.: Zibi Pump
Quantity: 1

Number: ES 8001749776
Item no.: 200
Date: 11/03/2022
Page: 2 / 7

KRTE 80-253/224XFG-K

Version no.: 1

Materials G

Pump casing (101)	Cast iron A 48 Class 35 B	Casing wear ring (502.1)	Cast iron A 48 Class 35 B
Discharge cover (163)	Cast iron A 48 Class 35 B	Cooling jacket (66-2)	Stainless steel A 276 Type 316 Ti
Shaft (210)	Chrome steel ASTM A276 Type 420 T	Motor housing (811)	Cast iron A 48 Class 35 B
Impeller (230)	Cast iron A 48 Class 35 B	Motor cable (824)	Chloroprene rubber
Bearing bracket (330)	Cast iron A 48 Class 35 B	Screw (900)	Stainless steel A 193 B8M
O-Ring (412)	Nitrile rubber NBR		

Packaging

IPPC Standard ISPM 15	Yes	Packaging for transport	Ship
Packaging category	B1 Wooden or plywood case, cover provided with polypropylene cellular sheet, outdoor storage up to 3 months	Outdoor storage at -40°C to +50°C for up to 3 months. Packet must be covered. No corrosion protection, only transport protection.	
Packaging for storage	Indoor		

Nameplates

Nameplates language	International	Duplicate nameplate	With
---------------------	---------------	---------------------	------

Certifications

Hydraulic performance test		Test participation	Non-witnessed
Acceptance standard	ISO 9906 2B	Quantity, non-witnessed	1
Quantity meas. points Q-H	5	Quantity, witnessed	0
Certificate	Inspection cert. 3.1 to EN 10204		

Data sheet



Customer item no.:35L/s @ 25m
Communication dated: 11/03/2022
Doc. no.: Zibi Pump
Quantity: 1

Number: ES 8001749776
Item no.: 200
Date: 11/03/2022
Page: 3 / 7

KRTE 80-253/224XFG-K

Version no.: 1

Installation parts

Installation type	stationary 2 guide rail	Type	Chain
Scope of supply	Pump with installation parts For guide rail arrangements, the guide rails are not included in KSB's scope of supply.	Material	CrNiMo steel 1.4404
		Length	5.00 m
		Max. load	400 kg
Installation depth	4.50 m	Lifting Bail	With
Material concept	G		

Duckfoot bend

Size	DN 80
Flange design	ASME
Duckfoot bend size (DN2 / DN3)	DN 80 Drilled according to ASME
Material	Cast iron A 48 Class 35 B
Mounting type	Composite anchor bolts
Foundation rail	Without

Claw

Design	Straight
Size	DN 80

Lifting chain / -rope

Performance curve



Customer item no.:35L/s @ 25m
 Communication dated: 11/03/2022
 Doc. no.: Zibi Pump
 Quantity: 1

Number: ES 8001749776
 Item no.:200
 Date: 11/03/2022
 Page: 4 / 7

KRTE 80-253/224XFG-K

Version no.: 1

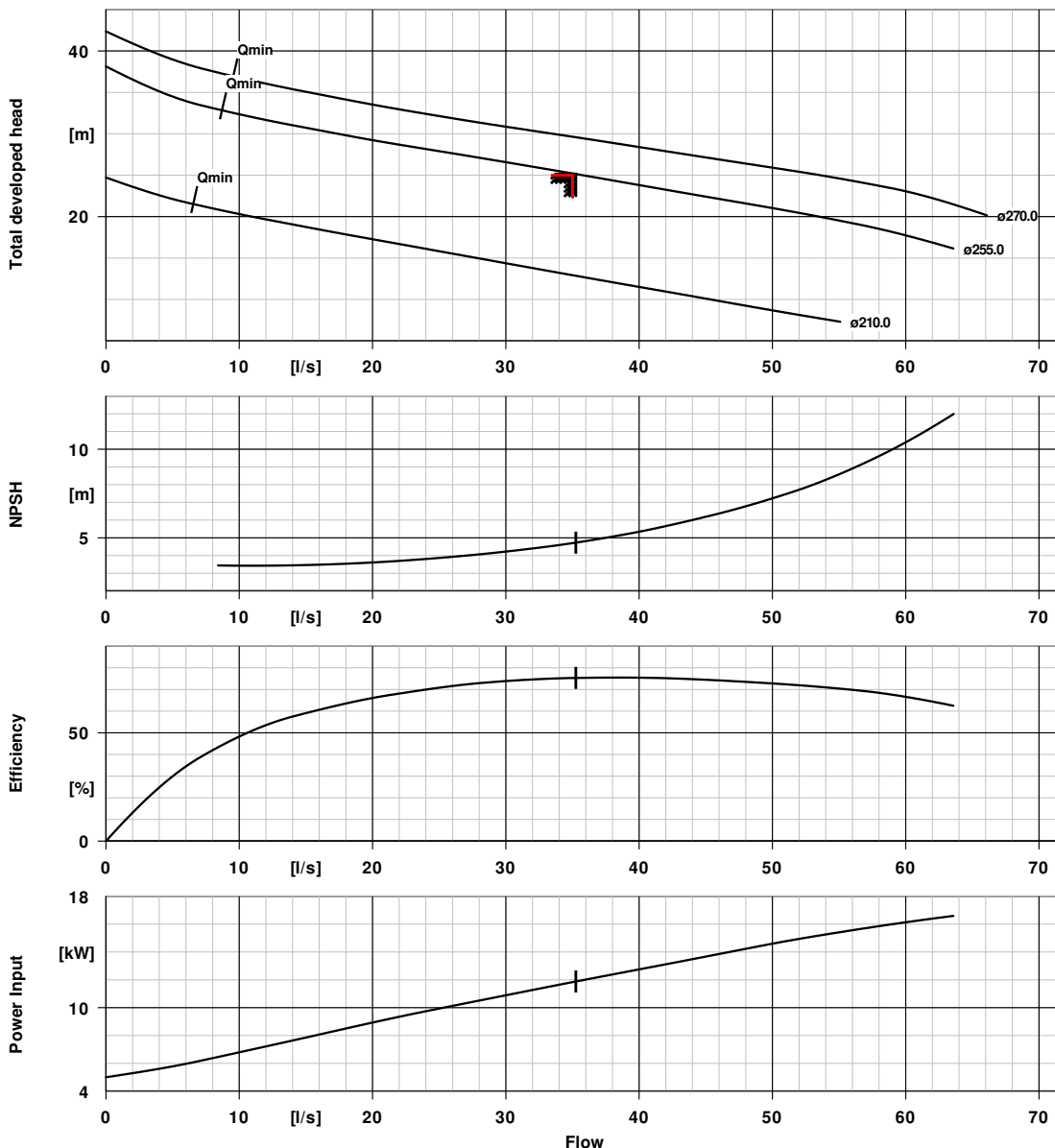

Curve data

Speed of rotation	1777 rpm	Efficiency	75.4 %
Fluid density	1030 kg/m ³	Power absorbed	11.88 kW
Viscosity	1.00 mm ² /s	NPSH 3%	4.73 m
Flow rate	35.253 l/s	Curve number	K43404/2
Requested flow rate	35.000 l/s	Effective impeller diameter	255.0 mm
Total developed head	25.15 m	Acceptance standard	ISO 9906 2B
Requested developed head	25.00 m		

Motor data sheet



Customer item no.:35L/s @ 25m
 Communication dated: 11/03/2022
 Doc. no.: Zibi Pump
 Quantity: 1

Number: ES 8001749776
 Item no.:200
 Date: 11/03/2022
 Page: 5 / 7

KRTE 80-253/224XFG-K

Version no.: 1

Motor data

Motor manufacturer	KSB	Rated speed	1765 rpm
Motor size	22F	Starting current ratio	6.7
Motor construction type	KSB Sub. motor	Starting mode	Direct-on-line starting
Motor material	Grey cast iron EN-GJL-250	Power cable	AWG 11-7+15-5
Efficiency class	not classified	Number of power cables	1
Rated voltage	575 V	Power cable Ø min.	21.0 mm
Frequency	60 Hz	Power cable Ø max.	23.0 mm
Motor power	18.64 kW	Cable standard	CSA
Rated current	24.5 A	Switching frequency	10.00 1/h

Curve data

The no-load point is not a guarantee point within the meaning of IEC 60034

Load	0.0 %	25.0 %	50.0 %	75.0 %	100.0 %
P2	0.00 kW	4.66 kW	9.32 kW	13.98 kW	18.64 kW
n	1800 rpm	1791 rpm	1782 rpm	1774 rpm	1765 rpm
P1	1.05 kW	5.60 kW	10.49 kW	15.59 kW	20.74 kW
I	9.1 A	11.0 A	14.6 A	19.4 A	24.5 A
Eta	0.0 %	83.2 %	88.9 %	89.7 %	89.9 %
cos phi	0.12	0.51	0.72	0.81	0.85

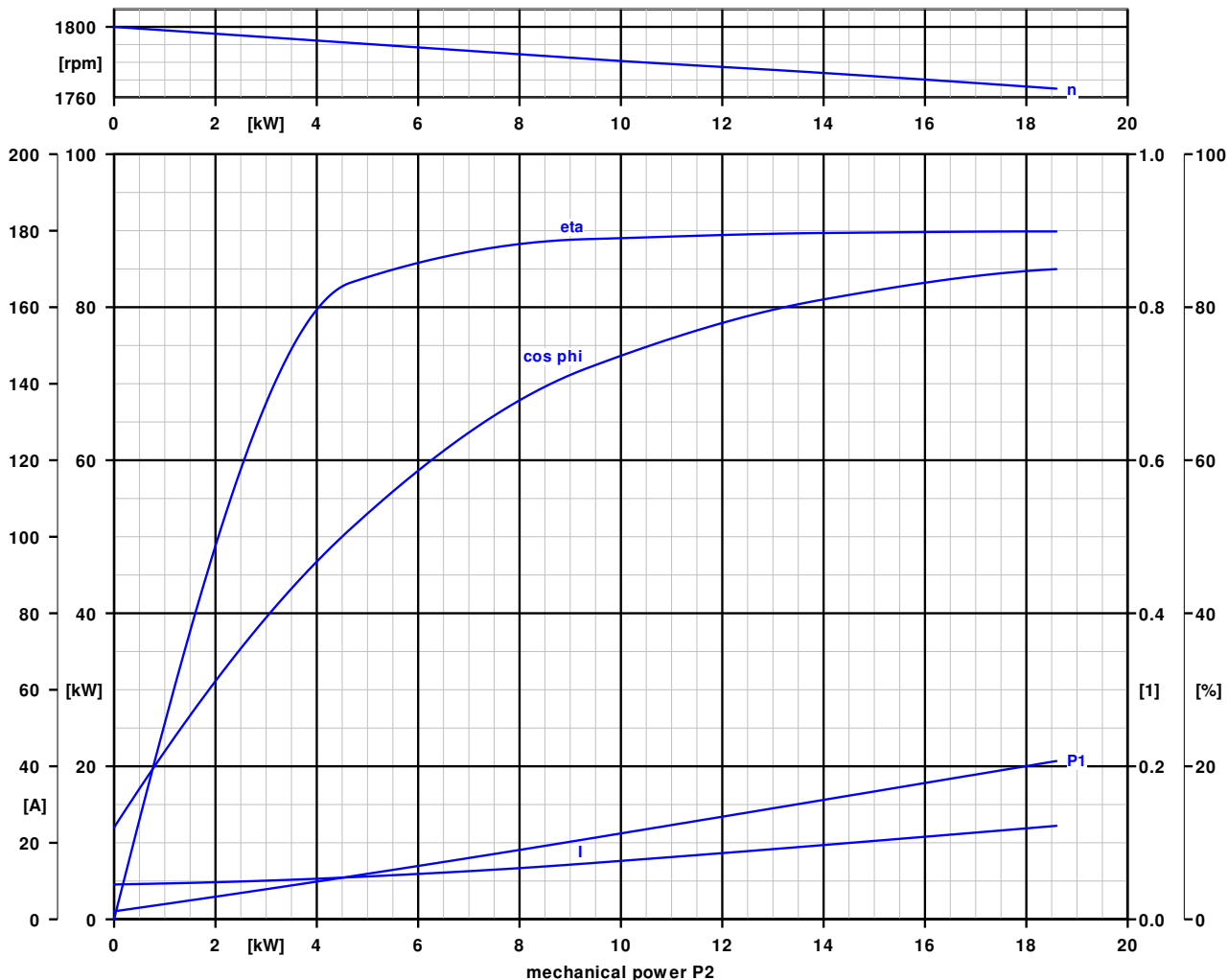

Installation plan



Customer item no.:35L/s @ 25m
 Communication dated: 11/03/2022
 Doc. no.: Zibi Pump
 Quantity: 1

Number: ES 8001749776
 Item no.:200
 Date: 11/03/2022
 Page: 6 / 7

KRTE 80-253/224XFG-K

Version no.: 1

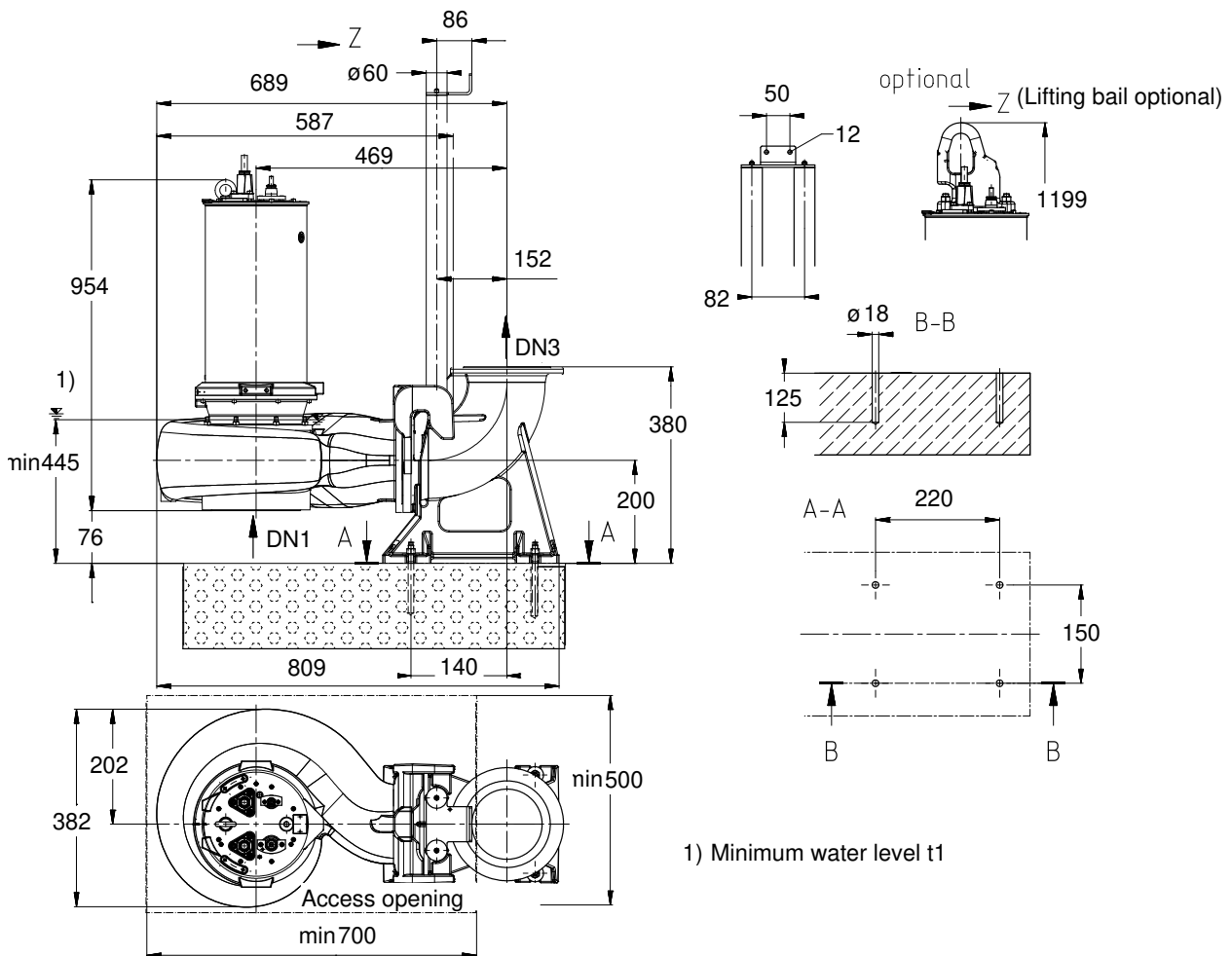

Drawing is not to scale

Dimensions in mm

Motor

Motor manufacturer	KSB
Motor size	22F
Motor power	18.64 kW
Number of poles	4
Speed of rotation	1765 rpm
Motor enclosure	IP68

Connections

Suction flange pump drilled according to(DN1)	unmachined
Duckfoot bend size (DN2 / DN3)	DN 80 Drilled according to ASME

Weight net

Pump, Motor, Cable	291 kg
Claw / Foot	35 kg
Total	326 kg

Installation plan



Customer item no.:35L/s @ 25m
Communication dated: 11/03/2022
Doc. no.: Zibi Pump
Quantity: 1

Number: ES 8001749776
Item no.:200
Date: 11/03/2022
Page: 7 / 7

KRTE 80-253/224XFG-K

Version no.: 1

Connect pipes without stress or strain!

Dimensional tolerances for shaft axis height: DIN 747
Dimensions without tolerances, middle tolerances to:
Connection dimensions for pumps:
Dimensions without tolerances - welded parts:
Dimensions without tolerances - gray cast iron parts:
Dimensions without tolerances - stainless steel parts:

ISO 2768-m
EN735
ISO 13920-B
ISO 8062-CT11
ISO 8062-CT12

For auxiliary connections see separate drawing.

Appendix 4

Email RE: System Flow

Gibbs, Andrew

From: Taryn Glancy <TGlancy@zibi.ca>
Sent: Friday, June 4, 2021 12:59 PM
To: Rusch, Peter; afobert; Gibbs, Andrew
Subject: Pump Station Design Flows
Attachments: Copy of san-2021-05-10_windmill_worksheet.xlsx

Follow Up Flag: Follow up
Flag Status: Completed

Hi Peter,

We have finalized the design flows for the pump station. Please proceed with design and schedule. Max capacity of the station would be 45 L/s, however likely operating at 30-35 L/s based on our discussions.

I have contacted Gemtec to review the slope stability, and will set up a meeting soon.

Thanks,



TARYN GLANCY, P. ENG.
PROJECT MANAGER

6 Booth St (Albert Island), Ottawa, ON K1R 6K8
C 613-219-2722 E TGlancy@zibi.ca

Appendix 5 Generator Sizing TM-1

Project Memo

H 282834

November 7, 2018

To: David Schaeffer Engineering Limited
Attention: Adam Fobert, P.Eng

From: Peter Rüsç / Grace Ning

cc:

**Re: Zibi Development / Chaudiere Island, City of Ottawa
Generator Sizing for Dual Use**

1. Introduction

Hatch has been retained by David Schaeffer Engineering Limited (DSEL) to design the pumping facilities for the Zibi Development on Chaudiere Island in the City of Ottawa. The pumping facilities will consist of a permanent pumping station, and there may be a temporary pumping station to allow for a longer planning timeframe for the overall site. DSEL has advised that the permanent station will have a peak sanitary flow of 32.7 L/s. Furthermore, Zibi has advised that Zibi requires a standby generator for other purposes on site. Hatch in conjunction with the DSEL suggested that it may be prudent to re-use the generator for the permanent pumping station, if feasible.

The flows from the permanent pumping station will be conveyed through twin forcemains, for discharge at Brickhill Street near Albert Street in the City of Ottawa. Hatch has previously completed a technical memorandum (Forcemain TM) to provide suggested forcemain diameters to DSEL. The forcemain TM is attached to this TM, and it is our understanding that the Forcemain TM may not be approved by the City of Ottawa at the time of writing.

The purpose of this TM is to set out probable pump sizes and derive a load list for the permanent pumping station that will require to be supplied by the generator. It has to be understood that the sizing is based on the background information presented in this memo and, depending on the final layout of the pumping station may result in an inadequate generator.

2. Pump Sizing

Hatch has, in the Forcemain TM derived a likely duty point for the pumping station, and as such has pre-selected 2 pumps for the following duty points:

- 33 L/s, with a total dynamic head of 25 m. This selection mimics the flow of the duty point referenced in the forcemain TM, with an additional allowance of 2.0m for additional depth / friction losses etc. This pump (from Flygt) would have a 15 kW motor.

If you disagree with any information contained herein, please advise immediately.

- 40 L/s, with a total dynamic head of 27 m. This selection provides for a [somewhat] random scenario where the PS needs to either provide for more flows, or for more total dynamic head. This pump from Flygt would have a 22 kW motor.

Hatch has also requested a pump selection from KSB, however these show a larger motor for the smaller pump and a similar sized motor for the larger pump. As such we believe that a pump with a 15 kW motor should adequately cover the duty scenario set out in the forcemain TM.

3. Generator Load Cases (for Pumping Station Use)

In the design of the conceptual layout of the permanent station, Hatch as assumed that, under certain extreme conditions, the second pump could be started, therefore the generator should be compliant with the following load cases:

- Load case 1:
 - Start Pump # 1, 15 kW, Soft Starter (peak current inrush = 3 x nominal)
 - Start Pump # 2, 15 kW, Soft Starter (peak current inrush = 3 x nominal)
 - Add miscellaneous electrical loads, 5 kW total, in 2 steps.
 - Voltage drop to be less than 25%
- Load case 2:
 - Start Pump # 1, 22 kW, VFD (peak current inrush = 2 x nominal)
 - Start Pump # 2, 22 kW, VFD (peak current inrush = 2 x nominal)
 - Add miscellaneous electrical loads, 5 kW total, in 2 steps.
 - Voltage drop to be less than 30%

Pumps of these sizes generally require 600 V power supply, and as such the genset should be a 3 Phase 600 V unit.

Zibi needs to determine the final generator size from the interim demands for other interim uses and the above noted proposed permanent pumping station demands.

Should there be any questions or concerns, please do not hesitate to contact us.

D

Appendix D Stormwater Management Calculations



EVALUATION OF RUNOFF COEFFICIENTS

Client: DREAM Windmill
Project: ZIBI
Location: Ottawa, Ontario
Project #: A000931



Area	Grassed Area (m ²)	Runoff Coefficient	Interlock Pavers Area (m ²)	Runoff Coefficient	Hard Surface Area (m ²)	Runoff Coefficient	Total Area (m ²)	Runoff Coefficient (10-year event)	Runoff Coefficient (100-year)
A1	322	0.20	98	0.75	1946	0.90	2366	0.80	0.95
A2	0	0.20	0	0.75	1228	0.90	1228	0.90	0.95
A3	0	0.20	0	0.75	1572	0.90	1572	0.90	0.95
A4	23	0.20	1358	0.75	728	0.90	2109	0.80	0.95
A5	28	0.20	736	0.75	0	0.90	764	0.73	0.91
A6	634	0.20	0	0.75	1479	0.90	2113	0.69	0.86
A7	0	0.20	959	0.75	0	0.90	959	0.75	0.94
A8	0	0.20	271	0.75	0	0.90	271	0.75	0.94
A9	38	0.20	1299	0.75	0	0.90	1337	0.73	0.92
TOTAL	1045	0.20	4721	0.75	6953	0.90	12719	0.79	0.95
A10	0	0.20	1963	0.75	0	0.90	1963	0.75	0.94
TOTAL	1045	0.20	6684	0.75	6953	0.90	14682	0.78	0.95

Prepared by: Julien Sauvé, P.Eng.
 PEO No.: 100200100

Date: 2022-03-17

Verified by: André Chaumont, P.Eng.
 PEO No.: 90409194

Date: 2022-03-17

Design Chart 1.07: Runoff Coefficients**- Urban for 5 to 10-Year Storms**

Land Use	Runoff Coefficient	
	Min.	Max.
Pavement - asphalt or concrete	0.80	0.95
- brick	0.70	0.85
Gravel roads and shoulders	0.40	0.60
Roofs	0.70	0.95
Business - downtown	0.70	0.95
- neighbourhood	0.50	0.70
- light	0.50	0.80
- heavy	0.60	0.90
Residential - single family urban	0.30	0.50
- multiple, detached	0.40	0.60
- multiple, attached	0.60	0.75
- suburban	0.25	0.40
Industrial - light	0.50	0.80
- heavy	0.60	0.90
Apartments	0.50	0.70
Parks, cemeteries	0.10	0.25
Playgrounds (unpaved)	0.20	0.35
Railroad yards	0.20	0.35
Unimproved areas	0.10	0.30
Lawns - Sandy soil		
- flat, to 2%	0.05	0.10
- average, 2 to 7%	0.10	0.15
- steep, over 7%	0.15	0.20
- Clayey soil		
- flat, to 2%	0.13	0.17
- average, 2 to 7%	0.18	0.22
- steep, over 7%	0.25	0.35

For flat or permeable surfaces, use the lower values. For steeper or more impervious surfaces, use the higher values. For return period of more than 10 years, increase above values as 25-year - add 10%, 50-year - add 20%, 100-year - add 25%.

The coefficients listed above are for unfrozen ground.



STORAGE VOLUME CALCULATIONS

Project: ZIBI
 Block 204
Project #: A000931
Station OTTAWA SEWER DESIGN GUIDELINES
Date: 4/5/2022 14:02

File #VALUE!
Location:

Description: Storage volume calculations with the rational method

Specified Release Rate: 100 L/s/ha

Area : A6 0.2113 ha
Runoff Coefficient C : 0.86
Rainfall Event : 100 ans
Discharge Flow Q : 0.02113 m³/s
Discharge Factor K : 1

Design Volume: 47.30 m³

Rainfall Pluviometry Coefficients	2 year		5 year		10 year	
	30 min. or less	Over 30 min.	30 min. or less	Over 30 min.	30 min. or less	Over 30 min.
A	732.951	732.951	998.071	998.071	1174.184	1174.184
B	6.199	6.199	6.053	6.053	6.014	6.014
C	0.810	0.810	0.814	0.814	0.816	0.816
Rainfall Pluviometry Coefficients	25 year		50 year		100 year	
	30 min. or less	Over 30 min.	30 min. or less	Over 30 min.	30 min. or less	Over 30 min.
A	1402.884	1402.884	1569.58	1569.58	1735.688	1735.688
B	6.018	6.018	6.014	6.014	6.014	6.014
C	0.819	0.819	0.820	0.820	0.820	0.820

Prepared by: Julien Sauvé
 PEO No.: 100200100

Date: 3/28/2022

Verified by: André Chaumont
 PEO No.: 90409194

Date: 3/28/2022

Init. _____

Rainfall Duration (min) <i>T</i> (1)	Rainfall Intensity (mm/h) <i>I</i> (2)	Rainfall intensity for Climate Ch. (mm/h) <i>I(2)*(factor)</i> (3)	Runoff Volume (m ³) <i>CIAT</i> (4)	Output Volume (m ³) <i>kQT</i> (5)	Retention Volume (m ³) <i>(4)-(5)</i> (6)
5.0	242.70	266.97	36.75	6.339	30.41
10.0	178.56	196.41	54.08	12.678	41.40
15.0	142.89	157.18	64.92	19.017	45.90
20.0	119.95	131.95	72.66	25.356	47.30
25.0	103.85	114.23	78.63	31.695	46.93
30.0	91.87	101.06	83.47	38.034	45.44
35.0	82.58	90.84	87.54	44.373	43.16
40.0	75.15	82.66	91.04	50.712	40.32
45.0	69.05	75.96	94.11	57.051	37.06
50.0	63.95	70.35	96.85	63.39	33.46
55.0	59.62	65.59	99.32	69.729	29.59
60.0	55.89	61.48	101.57	76.068	25.50
65.0	52.65	57.91	103.64	82.407	21.23
70.0	49.79	54.77	105.56	88.746	16.81
75.0	47.26	51.98	107.34	95.085	12.25
80.0	44.99	49.49	109.01	101.424	7.58
85.0	42.95	47.25	110.58	107.763	2.81
90.0	41.11	45.22	112.06	114.102	-2.04
95.0	39.43	43.38	113.46	120.441	-6.98
100.0	37.90	41.69	114.79	126.78	-11.99
105.0	36.50	40.15	116.06	133.119	-17.05
110.0	35.20	38.72	117.28	139.458	-22.18
115.0	34.01	37.41	118.44	145.797	-27.36
120.0	32.89	36.18	119.55	152.136	-32.58
125.0	31.86	35.05	120.62	158.475	-37.85
130.0	30.90	33.99	121.65	164.814	-43.16
135.0	30.00	33.00	122.65	171.153	-48.51
140.0	29.15	32.07	123.61	177.492	-53.89
145.0	28.36	31.19	124.54	183.831	-59.30
150.0	27.61	30.37	125.43	190.17	-64.74
155.0	26.91	29.60	126.31	196.509	-70.20
160.0	26.24	28.86	127.15	202.848	-75.70
165.0	25.61	28.17	127.97	209.187	-81.21
170.0	25.01	27.54	128.77	215.526	-86.75
175.0	24.44	26.89	129.55	221.865	-92.32
180.0	23.90	26.29	130.31	228.204	-97.90
185.0	23.39	25.73	131.04	234.543	-103.50
190.0	22.90	25.19	131.76	240.882	-109.12
195.0	22.43	24.67	132.47	247.221	-114.75
200.0	21.98	24.18	133.15	253.56	-120.41
205.0	21.55	23.71	133.82	259.899	-126.07
210.0	21.14	23.26	134.48	266.238	-131.76
215.0	20.75	22.83	135.12	272.577	-137.45
220.0	20.37	22.41	135.75	278.916	-143.16

225.0	20.01	22.01	136.37	285.255	-148.89
230.0	19.66	21.63	136.97	291.594	-154.62
235.0	19.33	21.26	137.57	297.933	-160.37
240.0	19.01	20.91	138.15	304.272	-166.12
245.0	18.69	20.56	138.72	310.611	-171.89
250.0	18.39	20.23	139.28	316.95	-177.67
255.0	18.11	19.92	139.83	323.289	-183.46
260.0	17.83	19.61	140.37	329.628	-189.26
265.0	17.56	19.31	140.90	335.967	-195.07
270.0	17.29	19.02	141.42	342.306	-200.88
275.0	17.04	18.75	141.94	348.645	-206.71
280.0	16.80	18.48	142.44	354.984	-212.54
285.0	16.56	18.22	142.94	361.323	-218.38
290.0	16.33	17.96	143.43	367.662	-224.23
295.0	16.11	17.72	143.91	374.001	-230.09
300.0	15.89	17.48	144.39	380.34	-235.95
305.0	15.68	17.25	144.86	386.679	-241.82
310.0	15.48	17.03	145.32	393.018	-247.70
315.0	15.28	16.81	145.77	399.357	-253.58
320.0	15.09	16.60	146.22	405.696	-259.47
325.0	14.90	16.39	146.67	412.035	-265.37
330.0	14.72	16.19	147.10	418.374	-271.27
335.0	14.54	16.00	147.53	424.713	-277.18
340.0	14.37	15.81	147.96	431.052	-283.09
345.0	14.20	15.62	148.38	437.391	-289.01
350.0	14.04	15.44	148.79	443.73	-294.94
355.0	13.88	15.26	149.20	450.069	-300.87
360.0	13.72	15.09	149.61	456.408	-306.80
Max Volume (V max):					47.30
Design Volume (V design) :					47.30

ZIBI
Block 204

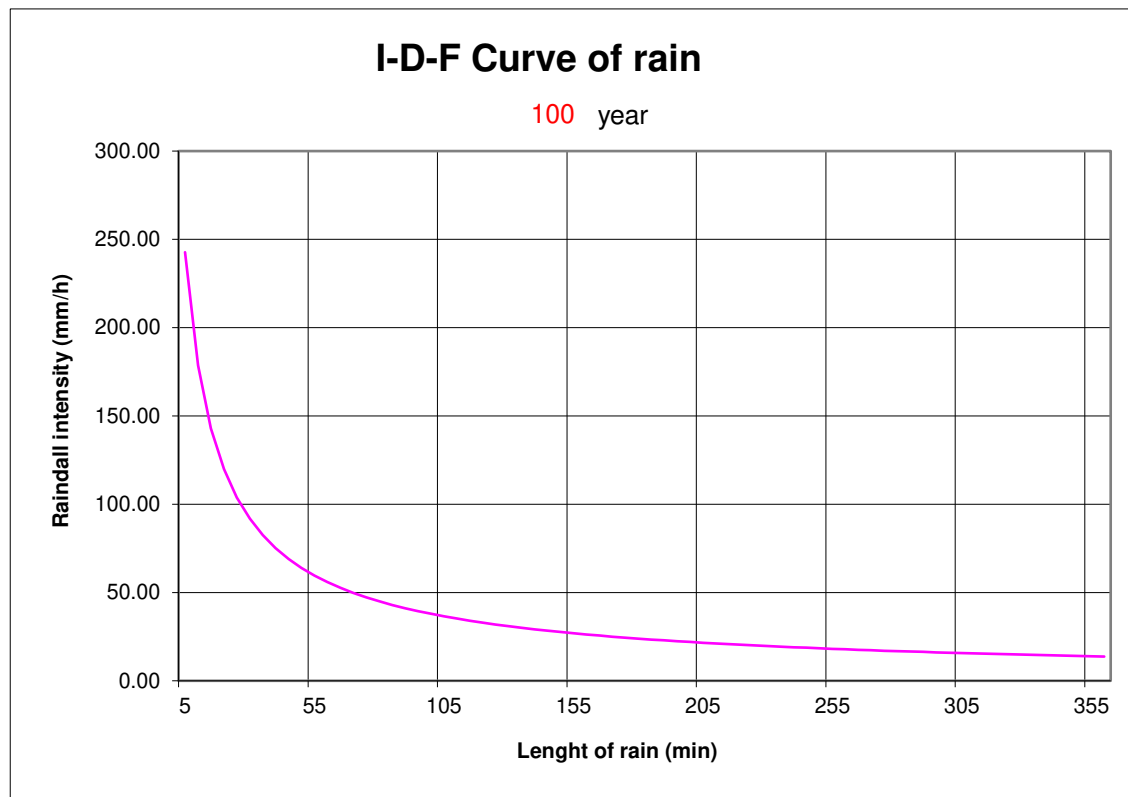
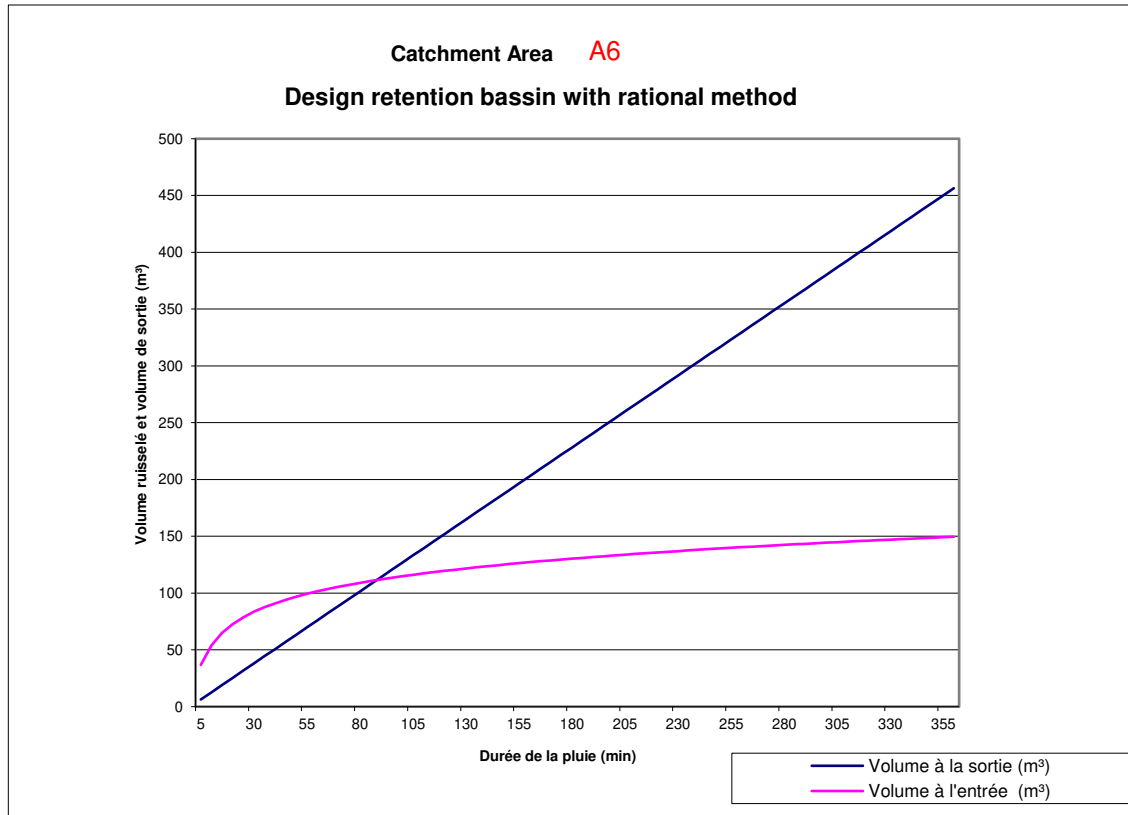



PROJECT NAME: ZIBI
 CIMA+ PROJECT NUM A000931
 CLIENT: DREAM
 PROJECT STATUS: Site Plan Application Block 204

STORM SEWER HYDRAULIC DESIGN SHEET (SSDS) – RATIONAL METHOD

APPLICABLE DESIGN GUIDELINES:

1. City of Ottawa Sewer Design Guidelines, 2012

STORM SEWER DESIGN CALCULATIONS:

DESIGN CRITERIA:

Rainfall Station: City of Ottawa Sewer Design Guidelines, 2012 (Macdonald-Cartier Airport)
 Manning's Coefficient (n): 0.013
 Maximum Permitted Velocity: 3.00 m/s
 Minimum Permitted Velocity: 0.80 m/s

IDF PARAMETERS AND RATIONAL FORMULA:

Design Storm (year):	5	
DF Regression Constants: (a)	998.071	
(b)	6.053	
(c)	0.814	
IDF Curve Equation (mm/hr):	$I = a / (\text{Time in min} + b)^c$	
Rational Formula (L/s):	$Q = 2.78 \cdot C \cdot I \cdot A$	where: Q = Flow (L/s) C = Runoff Coefficient I = Rainfall Intensity (mm/hr) A = Area (hectares)

OTHER FORMULAS USED IN CALCULATION TABLE:

Time of Concentration (minutes):	$T_c = T_i + T_f$	where: T _c = time of concentration (min) T _i = inlet time before pipe (min) T _f = time of flow in pipe (min) = L/(60*V) L = pipe length (m) V = actual velocity (m/s)
Manning's Equation (L/s):	$Q_{cap} = (1/n) \cdot A \cdot R^{2/3} \cdot S^{1/2}$	where: Q _{cap} = flow rate at capacity (L/s) n = Manning's roughness coefficient A = area of flow (m ²) R = hydraulic radius (m)* S = slope of pipe (%) <small>* Hydraulic radius is defined as the area of flow (m²) divided by wetted perimeter (m)</small>

Street/Catchment Name	LOCATION		RUNOFF C =	AREA (ha)	FLOW					SEWER DATA									
	From MH/CB	To MH/CB			Section 2.78*AC (ha)	Accum 2.78*AC (ha)	Time of Conc (min)	Rainfall Intensity (mm/hr)	Peak Flow (L/s)	Diameter (mm)	Material Type	Slope (%)	Length (m)	Capacity (full) (L/s)	Velocity (full) (m/s)	Velocity (actual) (m/s)	Time of Flow (min)	Ratio (%)	
A8	STM-110	STM-109	0.75	0.027	0.056	0.056	10.00	104.193	5.87	375	PVC	0.30%	32.40	96.03	0.87	0.47	1.14	6%	
A9	STM-111	STM-109	0.73	0.134	0.272	0.272	10.00	104.193	28.33	375	CONC	0.20%	59.40	78.41	0.71	0.65	1.53	36%	
-	STM-109	STM-108	-	-	-	0.328	11.53	96.765	31.76	375	PVC	0.30%	11.90	96.03	0.87	0.77	0.26	33%	
A7	STM-108	STM-107	0.75	0.096	0.200	0.528	11.78	95.632	50.53	375	PVC	0.30%	9.30	96.03	0.87	0.88	0.18	53%	
A5	STM-107	STM-106	0.73	0.076	0.154	0.683	11.96	94.870	64.76	450	PVC	0.40%	57.70	180.32	1.14	1.04	0.92	36%	
A6 (Block 204)			0.69	0.211	Controlled Flow by roof drain (100L/s/ha)				21.13										
-	STM-106	STM-105	-	-	-	0.683	12.88	91.086	83.31	450	CONC	1.02%	21.60	287.94	1.82	1.55	0.23	29%	
A4	STM-105	STM-104	0.80	0.211	0.469	1.152	13.11	90.188	125.02	450	CONC	1.12%	10.70	301.73	1.90	1.80	0.10	41%	
A1 & A2 & A3	STM-104	STM-103	0.85	0.516	1.219	2.371	13.21	89.810	234.09	450	CONC	1.47%	99.60	345.67	2.18	2.34	0.71	68%	
-	STM-103	STM-102B	-	-	-	2.371	13.92	87.204	227.91	525	CONC	0.64%	11.00	344.05	1.59	1.70	0.11	66%	
-	STM-102B	STM-102A	-	-	-	2.371	14.03	86.822	227.00	525	CONC	0.88%	9.10	403.43	1.87	1.92	0.08	56%	
-	STM-102A	STM-101	-	-	-	2.371	14.11	86.546	226.35	600	CONC	0.75%	14.80	531.75	1.89	1.81	0.14	43%	
-	STM-101	STM-102 (OGS)	-	-	-	2.371	14.25	86.072	225.22	600	CONC	0.38%	7.90	378.50	1.34	1.40	0.09	60%	
-	STM-102 (OGS)	HW100	-	-	-	2.371	14.34	85.748	224.45	600	CONC	0.43%	10.90	402.63	1.43	1.47	0.12	56%	
				1.271															

Existing Network

Prepared by: Julien Sauvé, P.Eng. Date: 8/30/2022
 PEO #100200100

Verified by: André Chaumont, P.Eng. Date: 8/30/2022
 PEO #90409194



PROJECT NAME: ZIBI
 CIMA+ PROJECT NUM A000931
 CLIENT: DREAM
 PROJECT STATUS: Site Plan Application Block 204

STORM SEWER HYDRAULIC DESIGN SHEET (SSDS) – RATIONAL METHOD

APPLICABLE DESIGN GUIDELINES:

1. City of Ottawa Sewer Design Guidelines, 2012

STORM SEWER DESIGN CALCULATIONS:

DESIGN CRITERIA:

Rainfall Station: City of Ottawa Sewer Design Guidelines, 2012 (Macdonald-Cartier Airport)
 Manning's Coefficient (n): 0.013
 Maximum Permitted Velocity: 3.00 m/s
 Minimum Permitted Velocity: 0.80 m/s

IDF PARAMETERS AND RATIONAL FORMULA:

Design Storm (year):	2	
DF Regression Constants: (a)	732.951	
(b)	6.199	
(c)	0.810	
IDF Curve Equation (mm/hr):	$I = a / (\text{Time in min} + b)^c$	
Rational Formula (L/s):	$Q = 2.78 \cdot C \cdot I \cdot A$	where: Q = Flow (L/s) C = Runoff Coefficient I = Rainfall Intensity (mm/hr) A = Area (hectares)

OTHER FORMULAS USED IN CALCULATION TABLE:

Time of Concentration (minutes):	$T_c = T_i + T_f$	where: T _c = time of concentration (min) T _i = inlet time before pipe (min) T _f = time of flow in pipe (min) = L/(60*V) L = pipe length (m) V = actual velocity (m/s)
Manning's Equation (L/s):	$Q_{cap} = (1/n) \cdot A \cdot R^{2/3} \cdot S^{1/2}$	where: Q _{cap} = flow rate at capacity (L/s) n = Manning's roughness coefficient A = area of flow (m ²) R = hydraulic radius (m)* S = slope of pipe (%) <small>* Hydraulic radius is defined as the area of flow (m²) divided by wetted perimeter (m)</small>

Street/Catchment Name	LOCATION		RUNOFF C =	AREA (ha)	FLOW					SEWER DATA									
	From MH/CB	To MH/CB			Section 2.78*AC (ha)	Accum 2.78*AC (ha)	Time of Conc (min)	Rainfall Intensity (mm/hr)	Peak Flow (L/s)	Diameter (mm)	Material Type	Slope (%)	Length (m)	Capacity (full) (L/s)	Velocity (full) (m/s)	Velocity (actual) (m/s)	Time of Flow (min)	Ratio (%)	
A8	STM-110	STM-109	0.75	0.027	0.056	0.056	10.00	76.805	4.32	375	PVC	0.30%	32.40	96.03	0.87	0.44	1.24	5%	
A9	STM-111	STM-109	0.73	0.134	0.272	0.272	10.00	76.805	20.89	375	CONC	0.20%	59.40	78.41	0.71	0.60	1.66	27%	
-	STM-109	STM-108	-	-	-	0.328	11.66	70.976	23.30	375	PVC	0.30%	11.90	96.03	0.87	0.71	0.28	24%	
A7	STM-108	STM-107	0.75	0.096	0.200	0.528	11.94	70.088	37.03	375	PVC	0.30%	9.30	96.03	0.87	0.81	0.19	39%	
A5	STM-107	STM-106	0.73	0.076	0.154	0.683	12.13	69.497	47.44	450	PVC	0.40%	57.70	180.32	1.14	0.94	1.02	26%	
A6 (Block 204)			0.69	0.211	Controlled Flow by roof drain (100L/s/ha)				21.13										
-	STM-106	STM-105	-	-	-	0.683	13.15	66.518	66.54	450	CONC	1.02%	21.60	287.94	1.82	1.46	0.25	23%	
A4	STM-105	STM-104	0.80	0.211	0.469	1.152	13.39	65.839	96.97	450	CONC	1.12%	10.70	301.73	1.90	1.67	0.11	32%	
A1 & A2 & A3	STM-104	STM-103	0.85	0.516	1.219	2.371	13.50	65.550	176.56	450	CONC	1.47%	99.60	345.67	2.18	2.18	0.76	51%	
-	STM-103	STM-102B	-	-	-	2.371	14.26	63.567	171.86	525	CONC	0.64%	11.00	344.05	1.59	1.58	0.12	50%	
-	STM-102B	STM-102A	-	-	-	2.371	14.38	63.276	171.17	525	CONC	0.88%	9.10	403.43	1.87	1.79	0.08	42%	
-	STM-102A	STM-101	-	-	-	2.371	14.46	63.066	170.67	600	CONC	0.75%	14.80	531.75	1.89	1.66	0.15	32%	
-	STM-101	STM-102 (OGS)	-	-	-	2.371	14.61	62.701	169.81	600	CONC	0.38%	7.90	378.50	1.34	1.29	0.10	45%	
-	STM-102 (OGS)	HW100	-	-	-	2.371	14.71	62.453	169.22	600	CONC	0.43%	10.90	402.63	1.43	1.37	0.13	42%	
				1.271															

Existing Network

Prepared by: Julien Sauvé, P.Eng.
PEO #100200100

Date: 8/30/2022

Verified by: André Chaumont, P.Eng.
PEO #90409194

Date: 8/30/2022



PROJECT NAME: ZIBI
 CIMA+ PROJECT NUM A000931
 CLIENT: DREAM
 PROJECT STATUS: Site Plan Application Block 204

STORM SEWER HYDRAULIC DESIGN SHEET (SSDS) – RATIONAL METHOD

APPLICABLE DESIGN GUIDELINES:

1. City of Ottawa Sewer Design Guidelines, 2012

STORM SEWER DESIGN CALCULATIONS:

DESIGN CRITERIA:

Rainfall Station: City of Ottawa Sewer Design Guidelines, 2012 (Macdonald-Cartier Airport)
 Manning's Coefficient (n): 0.013
 Maximum Permitted Velocity: 3.00 m/s
 Minimum Permitted Velocity: 0.80 m/s

IDF PARAMETERS AND RATIONAL FORMULA:

Design Storm (year):	100	
DF Regression Constants: (a)	1735.688	
(b)	6.014	
(c)	0.820	
IDF Curve Equation (mm/hr):	$I = a / (\text{Time in min} + b)^c$	
Rational Formula (L/s):	$Q = 2.78 \cdot C \cdot I \cdot A$	where: Q = Flow (L/s) C = Runoff Coefficient I = Rainfall Intensity (mm/hr) A = Area (hectares)

OTHER FORMULAS USED IN CALCULATION TABLE:

Time of Concentration (minutes):	$T_c = T_i + T_f$	where: T _c = time of concentration (min) T _i = inlet time before pipe (min) T _f = time of flow in pipe (min) = L/(60*V) L = pipe length (m) V = actual velocity (m/s)
Manning's Equation (L/s):	$Q_{cap} = (1/n) \cdot A \cdot R^{2/3} \cdot S^{1/2}$	where: Q _{cap} = flow rate at capacity (L/s) n = Manning's roughness coefficient A = area of flow (m ²) R = hydraulic radius (m)* S = slope of pipe (%) <small>* Hydraulic radius is defined as the area of flow (m²) divided by wetted perimeter (m)</small>

Street/Catchment Name	LOCATION		RUNOFF C =	AREA (ha)	FLOW					SEWER DATA									
	From MH/CB	To MH/CB			Section 2.78*AC (ha)	Accum 2.78*AC (ha)	Time of Conc (min)	Rainfall Intensity (mm/hr)	Peak Flow (L/s)	Diameter (mm)	Material Type	Slope (%)	Length (m)	Capacity (full) (L/s)	Velocity (full) (m/s)	Velocity (actual) (m/s)	Time of Flow (min)	Ratio (%)	
A8	STM-110	STM-109	0.94	0.027	0.071	0.071	10.00	178.559	12.60	375	PVC	0.30%	32.40	96.03	0.87	0.60	0.91	13%	
A9	STM-111	STM-109	0.92	0.134	0.343	0.343	10.00	178.559	61.20	375	CONC	0.20%	59.40	78.41	0.71	0.78	1.26	78%	
-	STM-109	STM-108	-	-	-	0.413	11.26	167.768	69.33	375	PVC	0.30%	11.90	96.03	0.87	0.94	0.21	72%	
A7	STM-108	STM-107	0.94	0.096	0.251	0.664	11.48	166.112	110.32	375	PVC	0.30%	9.30	96.03	0.87	0.87	0.18	115%	
A5	STM-107	STM-106	0.91	0.076	0.192	0.856	11.65	164.738	141.08	450	PVC	0.40%	57.70	180.32	1.14	1.26	0.77	78%	
A6 (Block 204)			0.86	0.211	Controlled Flow by roof drain (100L/s/ha)				21.13										
-	STM-106	STM-105	-	-	-	0.856	12.42	159.109	157.39	450	CONC	1.02%	21.60	287.94	1.82	1.86	0.19	55%	
A4	STM-105	STM-104	0.95	0.211	0.557	1.414	12.61	157.748	244.13	450	CONC	1.12%	10.70	301.73	1.90	2.11	0.08	81%	
A1 & A2 & A3	STM-104	STM-103	0.95	0.516	1.363	2.776	12.70	157.164	457.48	450	CONC	1.47%	99.60	345.67	2.18	2.18	0.76	132%	
-	STM-103	STM-102B	-	-	-	2.776	13.46	152.106	443.44	525	CONC	0.64%	11.00	344.05	1.59	1.59	0.12	129%	
-	STM-102B	STM-102A	-	-	-	2.776	13.57	151.372	441.40	525	CONC	0.88%	9.10	403.43	1.87	1.87	0.08	109%	
-	STM-102A	STM-101	-	-	-	2.776	13.65	150.860	439.98	600	CONC	0.75%	14.80	531.75	1.89	2.11	0.12	83%	
-	STM-101	STM-102 (OGS)	-	-	-	2.776	13.77	150.127	437.94	600	CONC	0.38%	7.90	378.50	1.34	1.34	0.10	116%	
-	STM-102 (OGS)	HW100	-	-	-	2.776	13.87	149.518	436.25	600	CONC	0.43%	10.90	402.63	1.43	1.43	0.13	108%	
				1.271															

Existing Network

Prepared by: Julien Sauvé, P.Eng.
 PEO #100200100

Date: 8/30/2022

Verified by: André Chaumont, P.Eng.
 PEO #90409194

Date: 8/30/2022

E

Appendix E Drawings



DREAM THEIA BLOCK 204A L

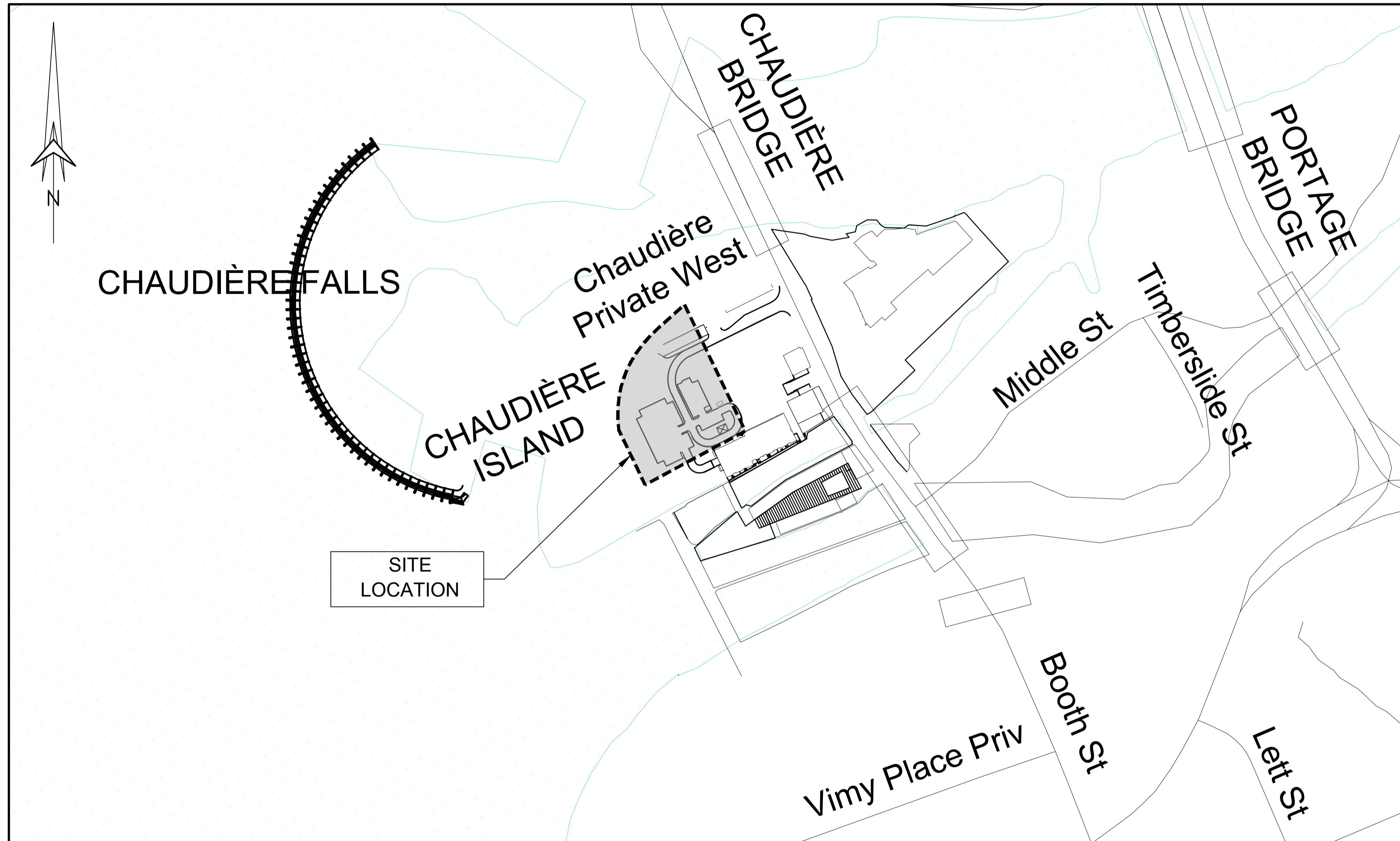

LIST OF DRAWINGS

PLAN No:	DESCRIPTION
C000	COVER PAGE
C001	TOPOGRAPHICAL SURVEY PLAN
C002	NOTES PLAN
C003	SEDIMENT AND EROSION CONTROL PLAN
C004	GRADE CONTROL AND DRAINAGE PLAN
C005	SITE SERVICING PLAN
C006A	PLANS AND PROFILE (CHAUDIÈRE PRIVATE)
C006B	PLANS AND PROFILE (MIWATE PRIVATE)
C007	CROSS-SECTIONS
C008	STORM WATER MANAGEMENT PLAN

ZIBI ONTARIO 315 PRIVE MIWATE, CHAUDIÈRE ISLAND OTTAWA, ONTARIO



71, 81, 91, 101, 111, 121, 131, 141, 151, 161, 171, 181, 191, 201, 211, 221, 231, 241, 251, 261, 271, 281, 291, 301, 311, 321, 331, 341, 351, 361, 371, 381, 391, 401, 411, 421, 431, 441, 451, 461, 471, 481, 491, 501, 511, 521, 531, 541, 551, 561, 571, 581, 591, 601, 611, 621, 631, 641, 651, 661, 671, 681, 691, 701, 711, 721, 731, 741, 751, 761, 771, 781, 791, 801, 811, 821, 831, 841, 851, 861, 871, 881, 891, 901, 911, 921, 931, 941, 951, 961, 971, 981, 991, 1001

DREAM THEIA BLOCK 204A L
ZIBI ONTARIO, 315 PRIVE MIWATE,
CHAUDIÈRE ISLAND, OTTAWA, ONTARIO
ISSUED FOR SITE PLAN APPLICATION, AUGUST 31st, 2022
City of Ottawa Project # : D07-12-22-0071
City of Ottawa Plan # : 18749

TITLEBLOCK 24x36 VERT ENG 3.0
 PRINT DATE: 2022/03/14 PAPER SIZE: A0
 PATH: C:\CIMA\C1000\Projects\A0000931_2022\Block 7_Ottawa\400_Drafting\400_Civil\1_Topo.dwg / LAYOUT: C001_Topo

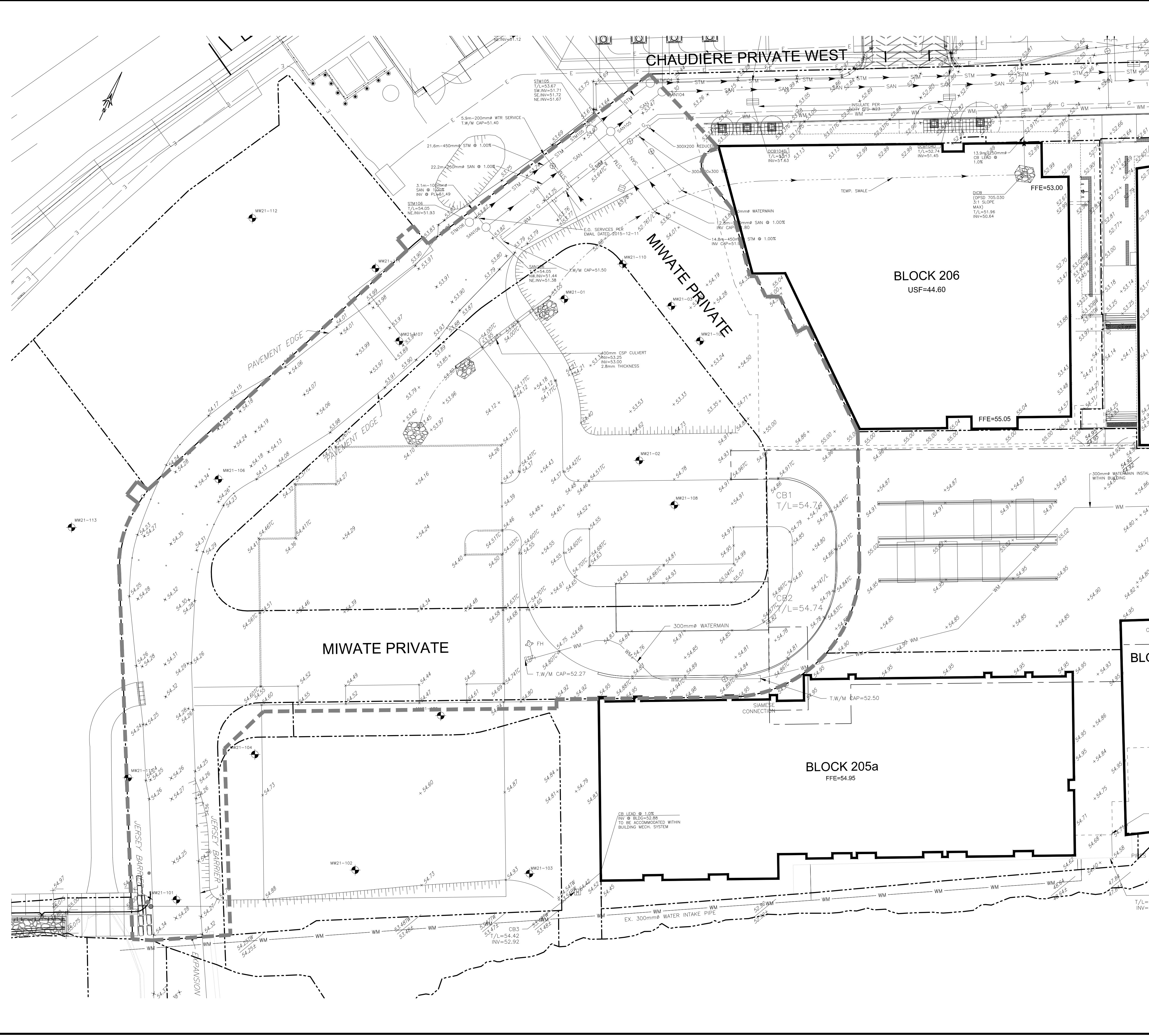

EXISTING

- WM WATERMAIN
- SAN SANITARY SEWER
- STM STORM SEWER
- D DRAIN
- G GAS LINE (APPROX. LOC.)
- T UNDERGROUND TELEPHONE (APPROX. LOC.)
- CA UNDERGROUND TRAFFIC CABLE (APPROX. LOC.)
- E UNDERGROUND ELECTRICITY (APPROX. LOC.)
- OVERHEAD WIRES
- LOT LINE
- RIGHT-OF-WAY LIMITS
- EASEMENT
- TOP OF SLOPE
- DITCH CENTER
- BOTTOM OF SLOPE

PROPOSED

- CATCHBASIN
- MANHOLE/CATCHBASIN
- MANHOLE
- FIRE HYDRANT
- VALVE
- REDUCER
- TEE
- VALVE CHAMBER
- PRIVATE UTILITIES (WATERMAIN)
- NATURAL GAS VALVE
- SIGN
- STOP SIGN
- TRAFFIC LIGHT
- ELECTRICITY POLE
- TELEPHONE POLE
- ELECT.-TEL-STREET LIGHT POLE
- ELECT.-TEL-TURNER POLE
- PRIVATE STREET LIGHT
- ELECTRICITY MANHOLE
- TELEPHONE MANHOLE
- SURVEY STATION
- ELEVATION
- INVERT
- BOREHOLE (LOC. APPROX.)
- WORK LIMIT

ABBREVIATIONS

- STM → STORM
- SAN → SANITARY
- WM → WATERMAIN
- WTR → WATER
- INV → INVERT
- MH → MANHOLE
- CB → CATCHBASIN
- TL → TOP OF LID
- OBV → OBVERT
- FFE → FINISHED FLOOR ELEVATION
- BLDG → BUILDING
- SERV → SERVICE

1:250 0 2.5 5 10 15m

No.	Date	Description	By
2	AUG. 31, 2022	ISSUED FOR SITE PLAN APPLICATION	A.C.
1	APR. 18, 2022	ISSUED FOR SITE PLAN APPLICATION	A.C.

STAMPS

DESIGNED BY

APPROVED BY

CIMA+

ENGINEER

TOPOGRAPHIC INFORMATION

- CHAUDIÈRE AND ALBERT ISLAND TOPOGRAPHIC INFORMATION PROVIDED BY FAIRHALL, MOFFATT & WOODLAND LIMITED, DATED JANUARY 15, 2015.
- BOOTH STREET/FLEET STREET/LOYD STREET/ALBERT STREET TOPOGRAPHIC INFORMATION PROVIDED BY STANTEC GEOMATICS LIMITED, DATED APRIL 20, 2018
- TEMPORARY ROAD CHAUDIÈRE & ALBERT STREET TOPOGRAPHIC INFORMATION PROVIDED BY STANTEC GEOMATICS LIMITED, DATED AUGUST 08, 2019

LEGAL INFORMATION

- LEGAL SURVEY PROVIDED BY STANTEC GEOMATICS LIMITED, DATED 2022

BENCH MARK

POINT	NORTHING	EASTING	ELEVATION	DESCRIPTION
10	5031271	365915.9320	54.3480	CP
85591	5031480	366018.9270	51.8200	BOLT
86037	5031454	366008.0430	52.0910	PKN
1000010	5031523	365993.0550	51.2040	MON 2018-007

NOTE OF CAUTION

THE GEODETIC COORDINATES OF EVERY ITEM INCLUDED AS PART OF THIS DOCUMENT ARE IN NAD83 - ORIGINAL / MTM - REFERENCE SYSTEM AND HAVE NO LEGAL VALUE. THE SITE LAYOUT MUST BE COMPLETED USING THE OFFICIAL BENCHMARKS OF AN ACCREDITED LAND SURVEYOR IN THE NAD83 - ORIGINAL / MTM - REFERENCE SYSTEM.

THE UNDERGROUND FEATURES AND INFORMATION THAT APPEAR ON THE DRAWINGS WERE OBTAINED FROM THE PUBLIC UTILITY COMPANIES AND/OR FROM THE CITY EACH RESPECTIVELY.

ALL INFORMATION UNDER THE LEGEND 'EXISTING' IS FOR INFORMATION ONLY. COMPLETE OR EXACT LOCATION AND ELEVATION OF UNDERGROUND SERVICES ARE NOT GUARANTEED.

CERTAIN UNDERGROUND FEATURES ON PRIVATE PROPERTY ARE NOT SHOWN ON THE CURRENT DRAWING.

ANYONE WHO PROCEEDS WITH EXCAVATION WORK SHALL VERIFY THE EXACT LOCATION OF ALL UNDERGROUND FEATURES, BY EXPLORATORY EXCAVATIONS, AND SHALL ASSUME FULL RESPONSIBILITY IF THERE IS ANY DAMAGE THAT OCCURS DURING WORK.

THE CONTRACTOR WILL HAVE THE RESPONSIBILITY AND THE OBLIGATION TO VALIDATE, BY EXPLORATORY EXCAVATION, THE SIZE OF THE PUBLIC UTILITIES UNDERGROUND SERVICES AND TO WARN THE ENGINEER OF ANY CONFLICT WITH THE PROJECTED WORK.

CLIENT:
DREAM UNLIMITED
 30 ADELAIDE STREET EAST
 SUITE 301
 TORONTO, ON, M5C 3H1

ZIBI (Project Address)
 310 Miwate Private
 OTTAWA, ONTARIO
 K1R 0E1

PROJECT NAME:
 ZIBI ONTARIO
 BLOCK 204
 315 PRIVE MIWATE PRIVATE,
 CHAUDIÈRE ISLAND
 OTTAWA, ONTARIO

SHEET TITLE:
 TOPOGRAPHICAL
 SURVEY PLAN

DISCIPLINE:
 CIVIL

DATEPLOT: S.C.POGGIOLI	SCALE: 1:250
DESIGNER: J.SAUVE	DATE: 2022/03/14
APPROVER: A.CHAUMONT	APPROVER: A.CHAUMONT
PROJECT No: A000931	DRAWING No: C001
SHEET No: 1 of 11	

GENERAL NOTES

1. GRADE CONTROL AND DRAINAGE - GENERAL

- 1.1. The Contractor must conform to all laws, codes, ordinances, and regulations adopted by federal, provincial or municipal government councils and government agencies, applying to work to be carried out.
1.2. Unless otherwise indicated, all materials and construction methods to be in accordance with the requirements of the latest edition of the City of Ottawa Design Guidelines, Ontario Provincial Standard Specifications and Drawings (OPSS and OPSD), the Ontario Ministry of Environment, Conservation and Parks (MECP), applicable Conservation Authorities, the municipal standard specifications and drawings, and all other governing authorities as they apply.
1.3. Wherever standards, laws and/or regulations are mentioned they refer to their current versions, modifications included.
1.4. The boreholes and test pits shown on the plan are for information purposes only. Their location on the plan is approximate. The Contractor must refer to the boreholes and test pit records to obtain information about observed stratigraphy on site.
1.5. The Contractor is responsible for obtaining all permits required to complete all works and bear cost of same, including road cut permit and water permit and their associated costs.
1.6. The Contractor is responsible for the coordination of his activities with others on site.
1.7. Submit copies of inspection and test reports to Owner's representative.
1.8. The location of existing underground municipal services and public utilities as shown on the plans are approximate. The Contractor must determine the exact location, size, material and elevation of all existing utilities (on-site and off-site) prior to any excavation work. Damage to any existing services and/or existing utilities during construction, whether or not shown on the drawings must be repaired by the Contractor at his own expense.
1.9. Site preparation including clearing, grubbing, stripping of topsoil, demolition, removal of unsuitable materials, cut, fill and rough grading of all areas to receive finished surfaces.
1.10. N/A
1.11. Compaction must conform to the following requirements:

- Exposed subgrade:
95% Standard Proctor maximum dry density (SPMDD)
Granular Subbase foundations:
99% Standard Proctor maximum dry density (SPMDD)
Granular Base foundations:
99% Standard Proctor maximum dry density (SPMDD)
Asphalt pavement:
As per OPSS/MUNI 310 / City of Ottawa Special Provisions
Subgrade fill (pavement areas - OPSS Select Subgrade Material):
95% Standard Proctor Maximum Dry Density (SPMDD)
Structural fill (building footprints OPSS Granular 'A' or Granular 'B' Type II Material):
98% Standard Proctor Maximum Dry Density (SPMDD)

- 1.12. If groundwater is encountered during construction, dewatering of excavations could be required as per OPSS/MUNI 518. It is assumed that groundwater may be controlled by sump and pumping methods. As required under the "Ontario Water Resources Act (OWRA)", the Contractor must register all water taking activities on Ontario's Environmental Activity and Sector Registry (EASR) if water taking exceeds 50,000 l/day, and obtain a "Permit to Take Water (PTTW)" if water taking exceeds 400,000 l/day. Furthermore, Contractor must provide all necessary measures required to ensure dewatering operations do not affect in any way the integrity of the existing surrounding buildings and must plan his work accordingly. Water Taking and Discharge Plan to be prepared by a Qualified Person as stipulated under O.Reg. 63/16.
1.13. Control disposal or runoff of water containing suspended materials or other harmful substances in accordance with local authority requirements and as follows:
1.13.1. Provide flocculation tanks, settling basins, or other treatment facilities to remove suspended solids or other materials to within the required parameters of the receiving body before discharging to storm sewers, watercourses or drainage areas.
1.13.2. Before discharging to storm sewers, watercourses or drainage areas, discharge water must be sampled and tested to ensure quality requirements in accordance with City of Ottawa Sewer Use By-Law No. 2003-514 and the MECP are adhered to. The Contractor is to perform all additional sampling and testing as required by City of Ottawa. All associated fees to be paid by the Contractor.
1.13.3. Where water is not suitable for discharge into the adjacent storm sewers, watercourses or drainage areas it must be discharged into the on-site sanitary sewer collection system, or disposed off-site at an approved disposal facility.
1.13.4. Sanitary Sewer Discharge:
1.13.4.1. When discharging to the sanitary sewer, the Contractor must obtain a Sanitary Sewer Agreement for Dewatering from the City of Ottawa in accordance with City of Ottawa Sewer Use By-Law No. 2003-514 and pay all associated fees.
1.13.4.2. A copy of the signed Sanitary Sewer Agreement for Dewatering must be provided to the Owner's Representative in advance of dewatering and discharge.
1.13.4.3. The Contractor must ensure all requirements of the Discharge Agreement are adhered to and all prerequisite requirements of the Agreement are in place prior to commencing dewatering.
1.13.4.4. Provide flow meter and record discharge rate in accordance with City of Ottawa requirements.
1.13.4.5. Dewatering discharge rate to sanitary sewer not to exceed rate specified by City.
1.13.4.6. For off-site disposal of dewatering effluent, Contractor to provide Departmental Representative proof of receipt that dewatering effluent was received at a licensed landfill facility and pay all associated disposal fees.
1.13.4.7. Contractor must provide name of proposed licensed disposal facility to Owner's Representative in advance of any dewatering waste leaving the site.
1.13.4.8. Contractor is responsible for paying all costs associated with any water quality sampling and testing required.

- 1.14. The Contractor must maintain benchmarks and landmark references as is. Otherwise these references will be repositioned by a certified land surveyor at the Contractor's expense.
1.15. The Contractor is the only person in charge of safety on the building site. The Contractor is responsible for providing adequate protection of the workers, other personnel and the general public, protection of materials, as well as maintaining in good condition the completed works and works to be completed. The Contractor must supply, install and maintain an appropriate safety fence along the work perimeter until the work is complete.
The Contractor must provide at any time:
- A sufficient number of barriers, posters, guards and others to ensure safety;
- Necessary conveniences for the completion of the work such as heating, lighting, ventilation, etc.
1.16. Temporary excavations in the overburden must be completed as per the requirements of the Occupational Health and Safety Act (OHSA), O. Reg. 213/91, Part III - Excavations.
The side slopes of excavations in the soil and fill overburden materials should either be cut back at acceptable slopes or should be retained by shoring systems from the start of the excavation until the structure is backfilled.
The excavation side slopes above the groundwater level extending to a maximum depth of 3 m should be cut back at 1H:1V or flatter. The flatter slope is required for excavation below groundwater level. The subsurface soil is considered to be mainly a Type 2 and 3 soil according to the Occupational Health and Safety Act and Regulations for Construction Projects. Slopes in excess of 3 m in height should be periodically inspected by the geotechnical consultant in order to detect if the slopes are exhibiting signs of distress.
1.17. The Contractor must pace deliveries and removals in order to minimize and control stockpiles.
1.18. Excavated soil must not be stockpiled directly at the top of excavations and heavy equipment kept away from the excavation sides.
1.19. Cleanliness on the site:
- The Contractor must clean roadways at his own cost as directed by the Owner's representative;
- All site roads and walkways to and from the construction zone must be kept clean at all times, from mud, dirt, granular material, debris, etc.;
- The Contractor must leave the work area clean at the end of each day;
- Materials and equipment must be laid out in an organized and safe manner;
- All material, equipment and temporary structures which are no longer necessary for the execution of the Contract must be removed from the site;
- If required the Contractor must use screens, bulkheads, or any other recognized means in order to reduce noise, dust, interference, obstruction, etc., in conformity with the requirements of the provincial and municipal authorities having jurisdiction.

2. DEMOLITION AND REMOVALS

- 2.1. The Contractor must visit the premises in order to be fully aware of existing conditions on site, including all elements to be removed and demolished. No claim will be accepted due to a poor evaluation of the work to be completed.
2.2. The Contractor must protect and maintain in service the existing works which must remain in place. If they are damaged, the Contractor must immediately make the replacements and necessary repairs to the satisfaction of the Owner's representative and without additional expense to the Owner.
2.3. The Contractor must perform the necessary clearing and grubbing in accordance with OPSS/MUNI 201.
2.4. The Contractor must carry out necessary saw cuts even if they are not shown on the drawings.
2.5. The Contractor must entirely remove the demolition wreckage from the construction site in accordance with the requirements of the MECP and in accordance with OPSS/MUNI 180 and OPSS/MUNI 510.
- The Contractor must discard recyclable demolition materials in collaboration with a regional recycling company. The Contractor must be able to provide proof, upon request, that the materials were properly recycled and that the chosen recycling company is recognized in the recycling field.
- All other demolition materials must be disposed off-site at authorized licensed landfills and in conformity with the applicable laws and regulations. The Contractor must be able to provide, upon request, copies of the disposal tickets.
2.6. The Contractor is responsible for locating existing public utilities and (if required) submit a request for the interruption of public utility services, such as gas, telephone, power, cable, sewers, watermain, etc.
2.7. The Contractor must conduct all removals required to make the work complete.
2.8. Unless otherwise specified, all materials, products and others coming from the demolition belong to the Contractor.
2.9. Surfaces and works located outside of the construction work limit must be reinstated as they were before beginning of work.

3. GENERAL SUBGRADE PREPARATION

- 3.1. Earth removal must be inspected by an experienced Geotechnical Engineer to ensure that all unsuitable materials are removed prior to the placement of fill, including concrete and/or others, and to confirm the compaction degree and condition of the founding soils. All unsuitable materials must be hauled off site and disposed as per provincial and municipal regulations.
3.2. Subgrade must be approved by experienced geotechnical personnel before proceeding with placement of fill.
3.3. All granular fill must be placed in maximum 300 mm thick loose lifts and compacted using suitable methods as per the requirements.
3.4. If soft spots develop in the subgrade during compaction or due to construction traffic, the affected areas should be excavated and replaced with OPSS Granular B Type II material.
3.5. If contaminated material is encountered during the work, the Contractor must dispose off-site all materials from the contaminated area in accordance with the requirements of the MECP and OPSS/MUNI 180. Prior to the start of work the Contractor must provide the name and location of landfill(s) where the contaminated materials will be disposed to the Consultant. The Contractor must obtain from the landfill Owner documents confirming that he has the right to accept the contaminated material. During the work, the contractor must provide the Consultant copies of all check-in receipts issued by the landfill Owner.
3.6. The Contractor is responsible for providing a confirmation that the imported material used as subgrade fill is free of any contaminants such as Petroleum Hydrocarbons (C₆-C₂₀), PAH (Polycyclic Aromatic Hydrocarbons), MAH (Monocyclic Aromatic Hydrocarbons) and metals like mercury, silver, arsenic, cadmium, cobalt, chromium, copper, tin, manganese, molybdenum, nickel, lead and zinc.

4. EXCAVATION AND BACKFILL

- 4.1. Subgrade preparation must be completed as per Section "3.0 General Subgrade Preparation".
4.2. The management of excess materials to comply with OPSS/MUNI 180.
4.3. Topsoil and deleterious fill, such as those containing organic materials, must be stripped from under any buildings, paved areas, pipe bedding, and other settlement sensitive structures.
4.4. Due to the relatively shallow depth of the bedrock surface and the anticipated founding level for the proposed building, all existing overburden material must be excavated from within the proposed building footprint.
4.5. Existing foundation walls and other construction debris must be entirely removed from within the building perimeter. Under paved areas, existing construction remnants, such as foundation walls, must be excavated to a minimum of 1 m below final grade.
4.6. Fill used for grading beneath the building areas must consist, unless otherwise specified, of clean imported granular fill, such as Ontario Provincial Standard Specifications (OPSS) Granular A or Granular B Type II. This material must be tested and approved prior to delivery to the site. The fill must be placed in lifts no greater than 300 mm thick and compacted using suitable compaction equipment for the lift thickness. Fill placed beneath the building must be compacted to at least 98% of its standard Proctor maximum dry density (SPMDD).
4.7. Non-specified existing fill along with site-excavated soil can be used as general landscaping fill where settlement of the ground surface is of minor concern. These materials should be spread in thin lifts and at least compacted by the tracks of the spreading equipment to minimize voids. If these materials are to be used to build up the subgrade level for areas to be paved, they should be compacted in thin lifts to a minimum density of 95% of their respective SPMDD.
4.8. Non-specified existing fill and site-excavated soils are not suitable for use as backfill against foundation walls unless a composite drainage blanket connected to a perimeter drainage system is provided.
4.9. Based on the bedrock encountered in the area, it is expected that line-drilling in conjunction with hoe-ramping or controlled blasting may be required to remove the bedrock. In areas of weathered bedrock and where only a small quantity of bedrock is to be removed, bedrock removal may be possible by hoe-ramping.
4.10. Rock excavation must conform to OPSS 403 MUNI / City of Ottawa Special Provision F-4031 and to all laws, codes, ordinances and regulations adopted by federal, provincial and municipal government councils and government agencies, applying to the work to be carried out.

SERVICING NOTES

1. MUNICIPAL SERVICES - GENERAL

- 1.1. Unless otherwise indicated, all materials and construction methods to be in accordance with the requirements of the latest edition of the Ontario Provincial Standard Specifications and Drawings (OPSS and OPSD), the Ontario Ministry of Environment, Conservation and Parks (MECP), applicable Conservation Authorities, the municipal standard specifications and drawings, and all other governing authorities as they apply.
1.2. Wherever standards, laws and/or regulations are mentioned they refer to their current versions, modifications included.
1.3. The boreholes and test pits shown on the plan are for information purposes only. Their location on the plan is approximate. The Contractor must refer to the boreholes and test pit records to obtain information about observed stratigraphy on site.
1.4. The location of existing underground municipal services and public utilities as shown on the plans are approximate. The Contractor must determine the exact location, size, material and elevation of all existing utilities (on-site and off-site) prior to any excavation work. Damage to any existing services and/or existing utilities during construction, whether or not shown on the drawings must be repaired by the Contractor at his own expense.
1.5. The Contractor is responsible for obtaining all permits required to complete all works and bear cost of same, including water permit and associated costs.
1.6. The Contractor is responsible for the coordination of his activities with others on-site.
1.7. Terminate and plug all service connections at 1.0 meter from edge of the building.

MATERIALS COMPACTION

Table with 2 columns: MATERIALS and COMPACTION. Rows include Pipe bedding (95% Standard Proctor Maximum Dry Density), Trench backfill and pipe cover (95% Standard Proctor Maximum Dry Density).

- 1.9. The Contractor is responsible for making or arranging all connections to the existing sewers as per municipal requirements. Prior to connection, the Contractor must provide, to the Engineer and the City for approval, all test results performed on the internal services. Test results must include C.C.T.V. inspection of sewers, infiltration/exfiltration tests for sewers and manholes, deformation tests of sewers, watermain hydrostatic leakage test, flushing and disinfecting operations, and bacteriological water analysis.
1.10. Advise the City Public Works at least 72 hours in advance before any connection to the City services. Coordinate with City as required.
1.11. The Contractor must determine the exact invert (geodetic elevation), diameter and construction material of the existing conduits at the proposed connections. He must also carry out, if necessary, exploratory excavations in order to determine the exact location and inverts of existing duct banks. This information must immediately be provided to the Engineer prior to start undertaking any municipal services work and a 48 hour period must be allocated to the Engineer for design review.
1.12. The Contractor is responsible for all excavation, backfill and reinstatement of all areas disturbed during construction to existing conditions or better and all associated works to the satisfaction of the Engineer and municipal authorities.
- Asphalt reinstatement must be in accordance with OPSS MUNI 310.
- Landscape areas to be reinstated with 150 mm of topsoil and sod in accordance with OPSS MUNI 802 and OPSS-MUNI 803.
1.13. It is recommended that a trench box be used at all times to protect personnel working in trenches with steep or vertical sides. Services are expected to be installed by "cut and cover" methods and excavations should not remain open for extended periods of time.
1.14. The pipe bedding for sewer and water pipes must consist of at least 150 mm of OPSS Granular A material. The material must be placed in maximum 300 mm thick lifts and compacted to a minimum of 95% of its SPMDD. The bedding material should extend at least to the spring line of the pipe.
1.15. The cover material, which must consist of OPSS Granular A, will extend from the spring line of the pipe to at least 300 mm above the cover of the pipe. The bedding material must be placed in maximum 300 mm thick loose lifts and compacted to a minimum of 95% of its SPMDD.
1.16. Where hard surface areas are considered above the trench backfill, the trench backfill material within the frost zone (about 1.8 m below finished grade) must match the soils exposed at the trench walls to minimize differential frost heaving. The trench backfill must be placed in maximum 300 mm thick loose lifts and compacted to a minimum of 95% of the material's SPMDD.
1.17. Dewatering of pipeline, utility and associated structure in rock excavations to be completed as per OPSS/MUNI 403.
1.18. Trenching, backfilling and compacting must conform to OPSS/MUNI 401.

2. WATERMAIN

- 2.1. Watermain, water service connections and associated appurtenances must be constructed in accordance with the Ontario Provincial Standard Specifications / City of Ottawa Standards Specifications / Ministry of Environment and Climate Change Requirements. Specifically watermain must conform to OPSS/MUNI 441.
2.2. Watermain must be constructed as per OPSS/MUNI 441 and specifically OPSS 802.010 for earth excavations and 802.013 for rock excavation. Bedding and cover material to be OPSS Granular 'A' compacted to 95% Standard Proctor Maximum Dry Density.
2.3. Watermain pipe materials must be class 150 PVC DR 18 or approved equivalent, unless otherwise shown on the Drawings. Materials must conform to OPSS 441.
2.4. All watermain must be installed with a minimum of 2.40 meters cover from finished grade. Where a minimum of 2.40 meters cover is not reached, thermal insulation is required as per City of Ottawa Details W22 and W23.
2.5. Watermain service connections must be installed a minimum of 2.40 meters from any catchbasin, manhole or object that may contribute to freezing. Thermal insulation must be installed as per City of Ottawa Details W22 and W23 where 2.40 meters of separation cannot be achieved.
2.6. Cathodic protection (if required) must be installed as per City of Ottawa Details W40 and W42.
2.7. Thrust block and restraints must be as per City of Ottawa Details W25.3, W25.4, W25.5 and W25.6.
2.8. Valves to be installed as per OPSS 441 and conform to the following:
- All valves must open in a counter clockwise direction;
- Designed for cold water working pressure of 1035 kPa;
- Types must be one of the following:
- Valves less than 75 mm to be brass or bronze gate valves;
- Valves greater than or equal to 75 mm, and less than or equal to 300 mm, to be cast or ductile iron gate valves;
- Valves greater than 300 mm up to and including 500 mm to be gate or butterfly valves;
- Valves greater than 500 mm to be butterfly valves.
2.9. A continuous 1/2 gauge copper tracer wire must be installed over all watermains. Tracer wire must be tied to all fire hydrants.
2.10. Valve box assembly to be as per City of Ottawa Detail W24.
2.11. When a watermain pipe crosses a sewer pipe, installation must be as per City of Ottawa Detail W25.2.
2.12. Watermains must be thoroughly flushed and cleaned to remove all dirt and debris prior to the disinfection process.
2.13. All watermains must be hydrostatically and bacteriologically tested as per provincial and municipal regulations. It is the Contractor's responsibility to ensure that all requirements are followed.
2.14. The Contractor must make arrangements with and give a minimum of 24 hours' notice to the City for the closing off of necessary valves in the water distribution system. The DREAM representative will operate valves at the time of tie-ins, etc. at no expense to the Contractor under normal conditions; however the Contractor will be responsible for all costs associated with emergency shutdowns if they occur outside of the normal working hours of the DREAM representative (Monday to Friday, 7.00 a.m. to 5.00 p.m.)

- 2.15. Hydrostatic testing to be completed as per OPSS 441.07.24. Testing must be completed under the supervision of the Contract Administrator. The test section will be either a section between valves or the completed watermain. Test pressure to be 1035 kPa.
2.16. Flushing and Disinfecting to be completed as per OPSS 441.07.25 under the supervision of the Contract Administrator.
2.17. The Contractor must obtain a permit from the City before using an existing fire hydrant located within the City's territory.
2.18. The Contractor must coordinate and pay the cost of connection, inspection and disinfection by municipal personnel.
2.19. Contractor must coordinate the supply and installation of water meter and remote water meter for the building with the mechanical engineer.
2.20. All phases of Zibi Ontario serviced and billed by meter chamber per city standard W32. Individual sub-metering provided based on future condominium requirements.
3. **STORM SEWER**
3.1. Storm sewers, laterals and storm service connections must be constructed in accordance with the Ontario Provincial Standard Specifications / City of Ottawa Standards Specifications / Ministry of Environment and Climate Change Requirements. Specifically storm sewers must conform to OPSS/MUNI 410.
3.2. PVC storm sewer material to conform to OPSS/MUNI 1841. PVC storm sewers to be installed as per OPSS 802.010 for earth excavation and 802.013 for rock excavation. Bedding and cover material to be OPSS Granular 'A'.
3.3. The allowable deflected pipe diameter when using flexible pipe is as follows:
- Pipes 100 to 750 mm: 7.5% of the base inside diameter of the pipe
- Greater than 750 mm: 5.0% of the base inside diameter of the pipe
3.4. Final backfill material for storm sewers must be approved native material or select subgrade material in conformance with OPSS MUNI 212.
3.5. Storm sewer pipes must be type PVC SDR-35, unless noted otherwise on the drawings.
3.6. All storm sewers to be C.C.T.V. inspected by the Contractor as per OPSS/MUNI 409. Report must be provided to the Engineer in two (2) copies and the C.C.T.V. inspection in DVD format only.
3.7. Storm manholes, manhole/catchbasins, catchbasins, ditch inlets and valve chambers to be installed as per OPSS 407.
3.8. Adjustment or rebuilding of manholes, manhole/catchbasins, catchbasins, ditch inlets and valve chambers to be completed as per OPSS 408 / City of Ottawa Special Provisions F-4080 and F-4081.
3.9. Excavating, backfilling, and compacting for manholes, manhole/catchbasins, catchbasins, ditch inlets and valve chambers to be completed as per OPSS 402.
3.10. Storm manhole, manhole/catchbasin and catchbasin excavations to be backfilled with OPSS Granular 'B' compacted to 99% Standard Proctor Maximum Dry Density (SPMDD). Joints between sections must be wrapped in a non-woven geotextile.
3.11. Storm manholes and manhole/catchbasins to be as per OPSS 701.010 and must be equipped with safety platform as per OPSS 404.020 when exceeding 5.0 m to the lowest invert.
3.12. Storm manhole frame and cover to be as per OPSS 401.010 Type 'A' closed cover.
3.13. A maintenance hole drop structure tee is to be used as per OPSS 1003.010 when the drop from the inlet invert to the outlet invert is greater than 600 mm and less than 1200 mm. A drop structure wye is to be used as per OPSS 1003.020 when the drop exceeds 1200 mm.
3.14. Storm service connections to rigid main sewer pipe to be as per City of Ottawa Detail S11. Connections to flexible main sewer pipe to be as per City of Ottawa Detail S11.1.
3.15. When a minimum cover of 1.5 meters is not reached, frost protection is required.
3.16. For building roof drain sizes and location refer to architectural and mechanical drawings.
3.17. For insulation of storm sewer, refer to city of Ottawa detail W22 and use a value of 1.5m instead of 2.4m to figure out thickness of board insulation.

3. SANITARY SEWER

- 3.1. Sanitary sewers, laterals and service connections must be constructed in accordance with the Ontario Provincial Standard Specifications / City of Ottawa Standards Specifications / Ministry of Environment and Climate Change Requirements. Specifically sanitary sewers must conform to OPSS/MUNI 410.
3.2. PVC sanitary sewer pipe material to be type PVC SDR-35, conforming to OPSS/MUNI 1841. PVC sanitary sewers to be installed as per OPSS 802.010 for earth excavation and 802.013 for rock excavation. Bedding and cover material to be OPSS Granular 'A'.
3.3. The allowable deflected pipe diameter when using flexible pipe is as follows:
- Pipes 100 to 750 mm: 7.5% of the base inside diameter of the pipe
- Greater than 750 mm: 5.0% of the base inside diameter of the pipe
3.4. Final backfill material for sanitary sewers must be approved native material or select subgrade material in conformance with OPSS MUNI 212.
3.5. All sanitary sewers to be C.C.T.V. inspected by the Contractor as per OPSS/MUNI 409. Report must be provided to the Engineer in two (2) copies and the C.C.T.V. inspection in DVD format only.
3.6. Sanitary manholes to be installed as per OPSS 407.
3.7. Adjustment or rebuilding of sanitary manholes to be completed as per OPSS 408.
3.8. Excavating, backfilling, and compacting for sanitary manholes to be completed as per OPSS/MUNI 402.
3.9. Sanitary manholes to be backfilled with OPSS Granular 'B' compacted to 99% Standard Proctor Maximum Dry Density (SPMDD). Joints between sections must be wrapped in a non-woven geotextile.
3.10. Sanitary manholes to be as per OPSS 701.010 and must be equipped with safety platform as per OPSS 404.020 when exceeding 5.0 m to the lowest invert.
3.11. Sanitary manhole frame and cover to be as per OPSS 401.010 Type 'A' closed cover.
3.12. A maintenance hole drop structure tee is to be used as per OPSS 1003.010 when the drop from the inlet invert to the outlet invert is greater than 600 mm and less than 1200 mm. A drop structure wye is to be used as per OPSS 1003.020 when the drop exceeds 1200 mm.
3.13. Sanitary service connections to rigid main sewer pipe to be as per City of Ottawa Detail S11. Connections to flexible main sewer pipe to be as per City of Ottawa Detail S11.1.
3.14. When a minimum cover of 1.8 meters is not reached, frost protection is required.
3.15. Benching is required inside the concrete bottom of sanitary manholes as per OPSS 701.021.

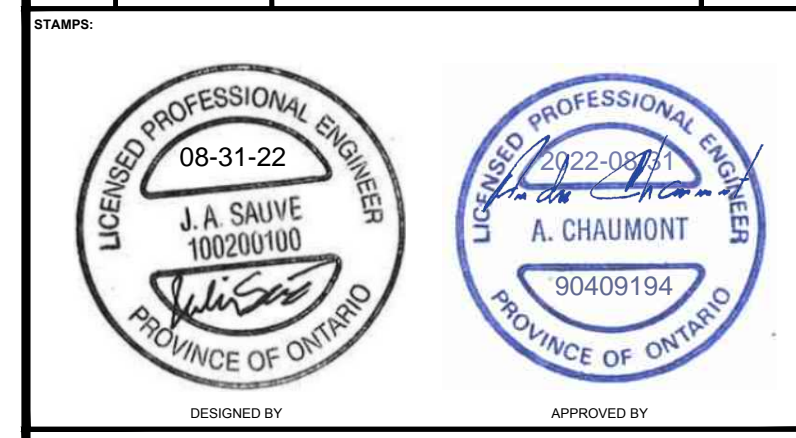

CLIENT: DREAM UNLIMITED
30 ADELAIDE STREET EAST
SUITE 301
TORONTO, ON, M5C 3H1
ZIBI (Project Address)
310 Mivata Private
OTTAWA, ONTARIO
K1R 0E1
PROJECT NAME: ZIBI ONTARIO
BLOCK 204
315 PRIVE MIWATE PRIVATE,
CHAUDIERE ISLAND
OTTAWA, ONTARIO

NOTES PLAN

Table with columns: DISCIPLINE, DRAWN BY, SCALE, DATE, and DRAWING NO. Includes project details like PROJECT NO. AA00931 and SHEET NO. 2 of 11.

TITLEBLOCK 24x36 VERT ENG 3.0
 PRINT DATE: 2022/03/14 (PAPER SIZE: A) PATH: Z:\C:\CIMA-C10001\Projects\A0000931_02\Block 7_Ottawa400_Drafting\400_Civil\3_Sediment&Erosion.dwg / LAYOUT: C003_SEC

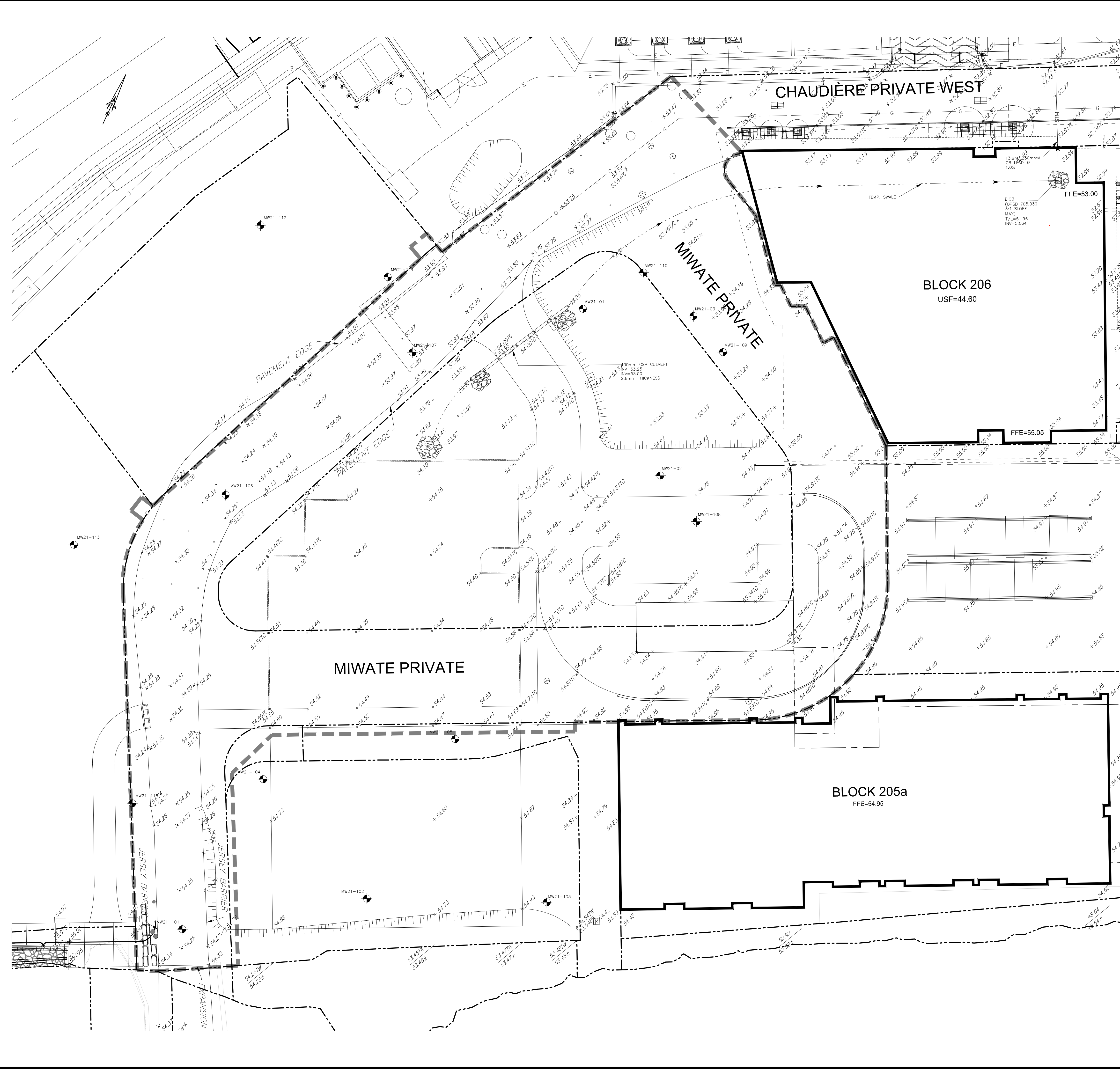

- 1. SEDIMENT AND EROSION CONTROL**
- Unless otherwise indicated, all materials and construction methods to be in accordance with the requirements of the latest edition of the Ontario Provincial Standard Specifications and Drawings (OPSS and OPSD), the Ontario Ministry of Environment, Conservation and Parks (MECP), applicable Conservation authorities, the municipal standard specifications and drawings, and all other governing authorities as they apply.
 - Wherever standards, laws and/or regulations are mentioned they refer to their current versions, modifications included.
 - Specifically, sediment and erosion control measures to be constructed as per OPSS/MUNI 805.
 - The Contractor must implement best management practices and provide adequate sediment and erosion control measures during construction:
 - Prevent soil erosion which can result from stormwater runoff or wind erosion during construction;
 - Prevent sediment deposits in the storm sewer and/or collecting streams and;
 - Prevent air pollution from dust and particulate matter.
 - Provisions must be made for sediment and erosion control measures prior to stripping the site of vegetation and other deleterious materials. Measures such as phase stripping, vegetation buffer zones, silt fences, straw bales, sediment traps/basins, rock checks, etc. must be constructed and maintained in order to control sediment, as required by the provincial and municipal governing authorities.
 - The Contractor must set up the measures shown on the plan, inspect them frequently and clean and repair or replace the deteriorated structures.
 - When the sediment and erosion control measures have to be removed in order to complete a portion of the work, these same measures must be reinstated.
 - When storing soil on site in piles the Contractor must cover each pile with tarps, straw or a geotextile fabric to avoid fine particle transport by wind and/or streaming rain water.
 - During the construction period, sediment capture silt sacks or filter cloths must be installed and maintained between the frame and cover of all catchbasins and catchbasin/manholes to minimize sediments entering the storm sewer system. All landscaping areas must be completed prior to the removal of the silt sacks or filter cloths.
 - The light duty silt fence barrier must be installed as per OPSS 219.110.
 - At all times the Contractor must maintain the municipal access roads clean and free of sediments. When cleaning the access roads, the Contractor must take the necessary precautions to clear the surfaces covered with sediment prior to cleaning with water.
 - For dust control, Contractor to apply calcium chloride (Type I - OPSS 2501 and CAN/CSS-15-1) and water with equipment approved by the Owner's representative at rate in accordance to OPSS/MUNI 506 when directed by Owner's representative.
 - At the end of the construction period, the Contractor is responsible for removal of the temporary sediment and erosion control measures and reconditioning the affected areas.
 - This plan is a "Living Document" which may be revised in the event that the control measures are not sufficient.

EXISTING

- WM - WATERMAIN
- SAN - SANITARY SEWER
- STM - STORM SEWER
- D - DRAIN
- G - GAS LINE (APPROX. LOC.)
- T - UNDERGROUND TELEPHONE (APPROX. LOC.)
- CA - UNDERGROUND TAFFIC CABLE (APPROX. LOC.)
- E - UNDERGROUND ELECTRICITY (APPROX. LOC.)
- OVERHEAD WIRES
- LOT LINE
- RIGHT-OF-WAY LIMITS
- EASEMENT
- TOP OF SLOPE
- DITCH CENTER
- BOTTOM OF SLOPE

PROPOSED

- CATCHBASIN
- MANHOLE/CATCHBASIN
- MANHOLE
- FIRE HYDRANT
- VALVE
- REDUCER
- TEE
- VALVE CHAMBER
- PRIVATE UTILITIES (WATERMAIN)
- NATURAL GAS VALVE
- SIGN
- STOP SIGN
- TRAFFIC LIGHT
- ELECTRICITY POLE
- TELEPHONE POLE
- ELECT.-TEL-STREET LIGHT POLE
- ELECT.-TEL-TRANSFORMER POLE
- PRIVATE STREET LIGHT
- ELECTRICITY MANHOLE
- TELEPHONE MANHOLE
- SURVEY STATION
- ELEVATION
- BOREHOLE (LOC. APPROX.)
- WORK LIMIT

ABBREVIATIONS

- STM - STORM
- SAN - SANITARY
- WM - WATERMAIN
- WTR - WATER
- INV - INVERT
- MH - MANHOLE
- CB - CATCHBASIN
- TL - TOP OF LID
- OBV - OVERT
- FFE - FINISHED FLOOR ELEVATION
- BLDG - BUILDING
- SERV - SERVICE

1:250 0 2.5 5 10 15m

No.	Date	Description	By
2	AUG. 31, 2022	ISSUED FOR SITE PLAN APPLICATION	A.C.
1	APR. 18, 2022	ISSUED FOR SITE PLAN APPLICATION	A.C.

DESIGNED BY:

APPROVED BY:

CIMA+

CLIENT: **DREAM UNLIMITED**
 30 ADELAIDE STREET EAST
 SUITE 301
 TORONTO, ON, M5C 3H1

ZIBI (Project Address)
 310 Miwate Private
 OTTAWA, ONTARIO
 K1R 0E1

PROJECT NAME: **ZIBI ONTARIO
 BLOCK 204
 315 PRIVE MIWATE PRIVATE,
 CHAUDIERE ISLAND
 OTTAWA, ONTARIO**

SHEET TITLE: **SEDIMENT & EROSION
 CONTROL PLAN**

DISCIPLINE:	
CIVIL	
DRAWN BY: S.C. POGGIOLI	SCALE: 1:250
DESIGNED BY: J. SAUVE	DATE: 2022/03/14
APPROVED BY: A. CHAUMONT	APPROVER: A. CHAUMONT
PROJECT No: A000931	DRAWING No: C003
SHEET No: 3 of 11	

NOTE OF CAUTION

THE GEODETIC COORDINATES OF EVERY ITEM INCLUDED AS PART OF THIS DOCUMENT ARE IN NAD83 - ORIGINAL / MTM - REFERENCE SYSTEM AND HAVE NO LEGAL VALUE. THE SITE LAYOUT MUST BE COMPLETED USING THE OFFICIAL BENCHMARKS OF AN ACCREDITED LAND SURVEYOR IN THE NAD83 - ORIGINAL / MTM - REFERENCE SYSTEM.

THE UNDERGROUND FEATURES AND INFORMATION THAT APPEAR ON THE DRAWINGS WERE OBTAINED FROM THE PUBLIC UTILITY COMPANIES AND/OR FROM THE CITY EACH RESPECTIVELY.

ALL INFORMATION UNDER THE LEGEND 'EXISTING' IS FOR INFORMATION ONLY. COMPLETE OR EXACT LOCATION AND ELEVATION OF UNDERGROUND SERVICES ARE NOT GUARANTEED.

CERTAIN UNDERGROUND FEATURES ON PRIVATE PROPERTY ARE NOT SHOWN ON THE CURRENT DRAWING.

ANYONE WHO PROCEEDS WITH EXCAVATION WORK SHALL VERIFY THE EXACT LOCATION OF ALL UNDERGROUND FEATURES, BY EXPLORATORY EXCAVATIONS, AND SHALL ASSUME FULL RESPONSIBILITY IF THERE IS ANY DAMAGE THAT OCCURS DURING WORK.

THE CONTRACTOR WILL HAVE THE RESPONSIBILITY AND THE OBLIGATION TO VALIDATE, BY EXPLORATORY EXCAVATION, THE SIZE OF THE PUBLIC UTILITIES UNDERGROUND SERVICES AND TO WARN THE ENGINEER OF ANY CONFLICT WITH THE PROJECTED WORK.

TITLE BLOCK 24x36 VERT ENG 3.0
 PRINT DATE: 2022/03/14 PAPER SIZE: A0
 PATH: C:\CIMA\C10001\Projects\A0000931_2021\07 - Block 7 - Ottawa\A0000931_2021\Grading.dwg / LAYOUT: C104

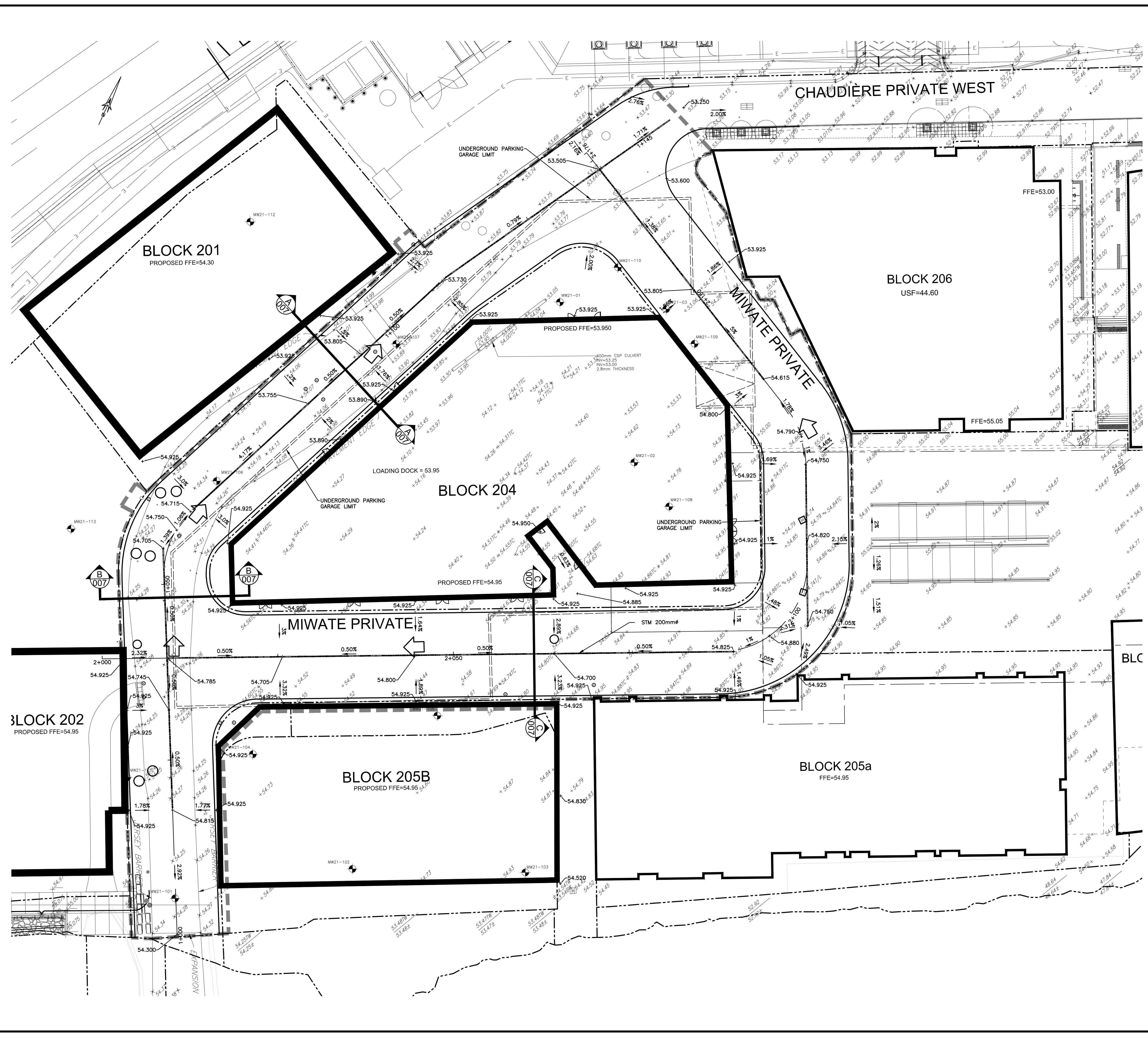

EXISTING

- WM WATERMAIN
- SAN SANITARY SEWER
- STM STORM SEWER
- D DRAIN
- G GAS LINE (APPROX. LOC.)
- T UNDERGROUND TELEPHONE (APPROX. LOC.)
- CA UNDERGROUND TRAFFIC CABLE (APPROX. LOC.)
- E UNDERGROUND ELECTRICITY (APPROX. LOC.)
- OVERHEAD WIRES
- LOT LINE
- RIGHT-OF-WAY LIMITS
- EASEMENT
- TOP OF SLOPE
- DITCH CENTER
- BOTTOM OF SLOPE

PROPOSED

- CATCHBASIN
- MANHOLE/CATCHBASIN
- MANHOLE
- FIRE HYDRANT
- REDUCER
- VALVE
- REDUCER
- TEE
- VALVE CHAMBER
- PRIVATE UTILITIES (WATERMAIN)
- NATURAL GAS VALVE
- SIGN
- STOP SIGN
- TRAFFIC LIGHT
- ELECTRICITY POLE
- TELEPHONE POLE
- ELECT.-TEL-STREET LIGHT POLE
- ELECT.-TEL-TRANSFORMER POLE
- PRIVATE STREET LIGHT
- ELECTRICITY MANHOLE
- TELEPHONE MANHOLE
- SURVEY STATION
- ELEVATION
- + 99,000
- BOREHOLE (LOC. APPROX.)
- OVERLAND FLOW
- TRENCH DRAIN
- WORK LIMIT
- UNDERGROUND PARKING GARAGE LIMIT

ABBREVIATIONS

- STM → STORM
- SAN → SANITARY
- WM → WATERMAIN
- WTR → WATER
- INV → INVERT
- MH → MANHOLE
- CB → CATCHBASIN
- TL → TOP OF LID
- OBV → OBVERT
- FFE → FINISHED FLOOR ELEVATION
- BLDG → BUILDING
- SERV → SERVICE

1:250 0 2.5 5 10 15m

No.	Date	Description	By
2	AUG. 31, 2022	ISSUED FOR SITE PLAN APPLICATION	A.C.
1	APR. 18, 2022	ISSUED FOR SITE PLAN APPLICATION	A.C.

DESIGNED BY:

APPROVED BY:

CIMA+

DREAM UNLIMITED
 30 ADELAIDE STREET EAST
 SUITE 301
 TORONTO, ON, M5C 3H1

ZIBI (Project Address)
 310 Miwate Private
 OTTAWA, ONTARIO
 K1R 0E1

PROJECT NAME:
 ZIBI ONTARIO
 BLOCK 204
 315 PRIVE MIWATE PRIVATE,
 CHAUDIERE ISLAND
 OTTAWA, ONTARIO

SHEET TITLE:
 GRADE CONTROL AND
 DRAINAGE PLAN

DISCIPLINE:	
CIVIL	
DESIGNER: S.C.POGGIOLI	SCALE: 1:250
DESIGNER: J.SAUVÉ	DATE: 2022/03/14
APPROVER: A.CHAUMONT	APPROVER: A.CHAUMONT
PROJECT No: A000931	DRAWING No: C004
SHEET No: 5 of 11	

NOTE OF CAUTION

THE GEODETIC COORDINATES OF EVERY ITEM INCLUDED AS PART OF THIS DOCUMENT ARE IN NAD83 - ORIGINAL / MTM - REFERENCE SYSTEM AND HAVE NO LEGAL VALUE. THE SITE LAYOUT MUST BE COMPLETED USING THE OFFICIAL BENCHMARKS OF AN ACCREDITED LAND SURVEYOR IN THE NAD83 - ORIGINAL / MTM - REFERENCE SYSTEM.

THE UNDERGROUND FEATURES AND INFORMATION THAT APPEAR ON THE DRAWINGS WERE OBTAINED FROM THE PUBLIC UTILITY COMPANIES AND/OR FROM THE CITY EACH RESPECTIVELY.

ALL INFORMATION UNDER THE LEGEND 'EXISTING' IS FOR INFORMATION ONLY. COMPLETE OR EXACT LOCATION AND ELEVATION OF UNDERGROUND SERVICES ARE NOT GUARANTEED.

CERTAIN UNDERGROUND FEATURES ON PRIVATE PROPERTY ARE NOT SHOWN ON THE CURRENT DRAWING.

ANYONE WHO PROCEEDS WITH EXCAVATION WORK SHALL VERIFY THE EXACT LOCATION OF ALL UNDERGROUND FEATURES, BY EXPLORATORY EXCAVATIONS, AND SHALL ASSUME FULL RESPONSIBILITY IF THERE IS ANY DAMAGE THAT OCCURS DURING WORK.

THE CONTRACTOR WILL HAVE THE RESPONSIBILITY AND THE OBLIGATION TO VALIDATE, BY EXPLORATORY EXCAVATION, THE SIZE OF THE PUBLIC UTILITIES UNDERGROUND SERVICES AND TO WARN THE ENGINEER OF ANY CONFLICT WITH THE PROJECTED WORK.

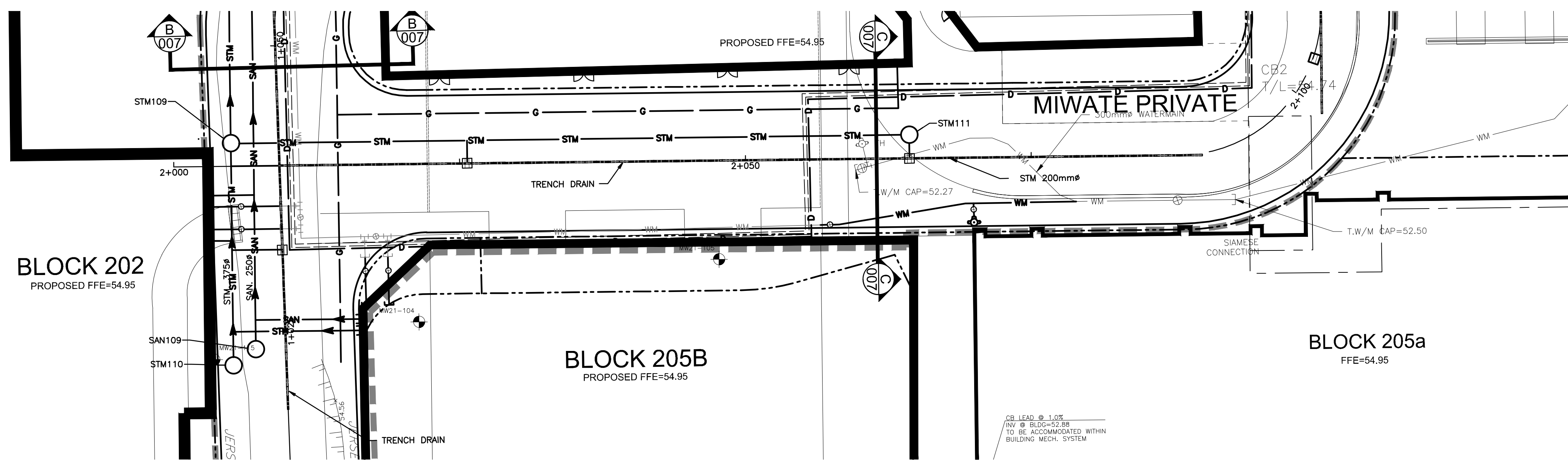

EXISTING		PROPOSED	
WM	WATERMAIN	WM	WATERMAIN
SAN	SANITARY SEWER	SAN	SANITARY SEWER
STM	STORM SEWER	STM	STORM SEWER
D	DRAIN	D	DRAIN
G	GAS LINE (APPROX. LOC.)	G	GAS LINE (APPROX. LOC.)
T	UNDERGROUND TELEPHONE (APPROX. LOC.)	T	UNDERGROUND TELEPHONE (APPROX. LOC.)
CA	UNDERGROUND TRAFFIC CABLE (APPROX. LOC.)	CA	UNDERGROUND TRAFFIC CABLE (APPROX. LOC.)
E	UNDERGROUND ELECTRICITY (APPROX. LOC.)	E	UNDERGROUND ELECTRICITY (APPROX. LOC.)
OT	OVERHEAD WIRES	OT	OVERHEAD WIRES
---	LOT LINE	---	LOT LINE
---	RIGHT-OF-WAY LIMITS	---	RIGHT-OF-WAY LIMITS
---	EASEMENT	---	EASEMENT
---	TOP OF SLOPE	---	TOP OF SLOPE
---	DITCH CENTER	---	DITCH CENTER
---	BOTTOM OF SLOPE	---	BOTTOM OF SLOPE
---	CATCHBASIN	---	CATCHBASIN
---	MANHOLE/CATCHBASIN	---	MANHOLE/CATCHBASIN
---	MANHOLE	---	MANHOLE
---	FIRE HYDRANT	---	FIRE HYDRANT
---	VALVE	---	VALVE
---	REDUCER	---	REDUCER
---	TEE	---	TEE
---	VALVE CHAMBER	---	VALVE CHAMBER
---	PRIVATE UTILITIES (WATERMAIN)	---	PRIVATE UTILITIES (WATERMAIN)
---	NATURAL GAS VALVE	---	NATURAL GAS VALVE
---	TRENCH DRAIN	---	TRENCH DRAIN
---	SIGN	---	SIGN
---	STOP SIGN	---	STOP SIGN
---	TRAFFIC LIGHT	---	TRAFFIC LIGHT
---	ELECTRICITY POLE	---	ELECTRICITY POLE
---	TELEPHONE POLE	---	TELEPHONE POLE
---	E.T.	---	ELECT.-TEL.-STREET LIGHT POLE
---	E.T.	---	ELECT.-TEL.-TRANSFORMER POLE
---	---	---	PRIVATE STREET LIGHT
---	---	---	ELECTRICITY MANHOLE
---	---	---	TELEPHONE MANHOLE
---	---	---	SURVEY STATION
---	---	---	WATERMAIN INSULATION
---	---	---	UNDERGROUND PARKING
---	---	---	GARAGE OUTLINE
---	---	---	WORKHOLE (LOC. APPROX.)
---	---	---	WORK LIMIT

ABBREVIATIONS

STM	→	STORM
SAN	→	SANITARY
WM	→	WATERMAIN
WTR	→	WATER
INV	→	INVERT
MH	→	MANHOLE
CB	→	CATCHBASIN
TL	→	TOP OF LID
OBV	→	OBVERT
FFE	→	FINISHED FLOOR ELEVATION
BLDG	→	BUILDING
SERV	→	SERVICE

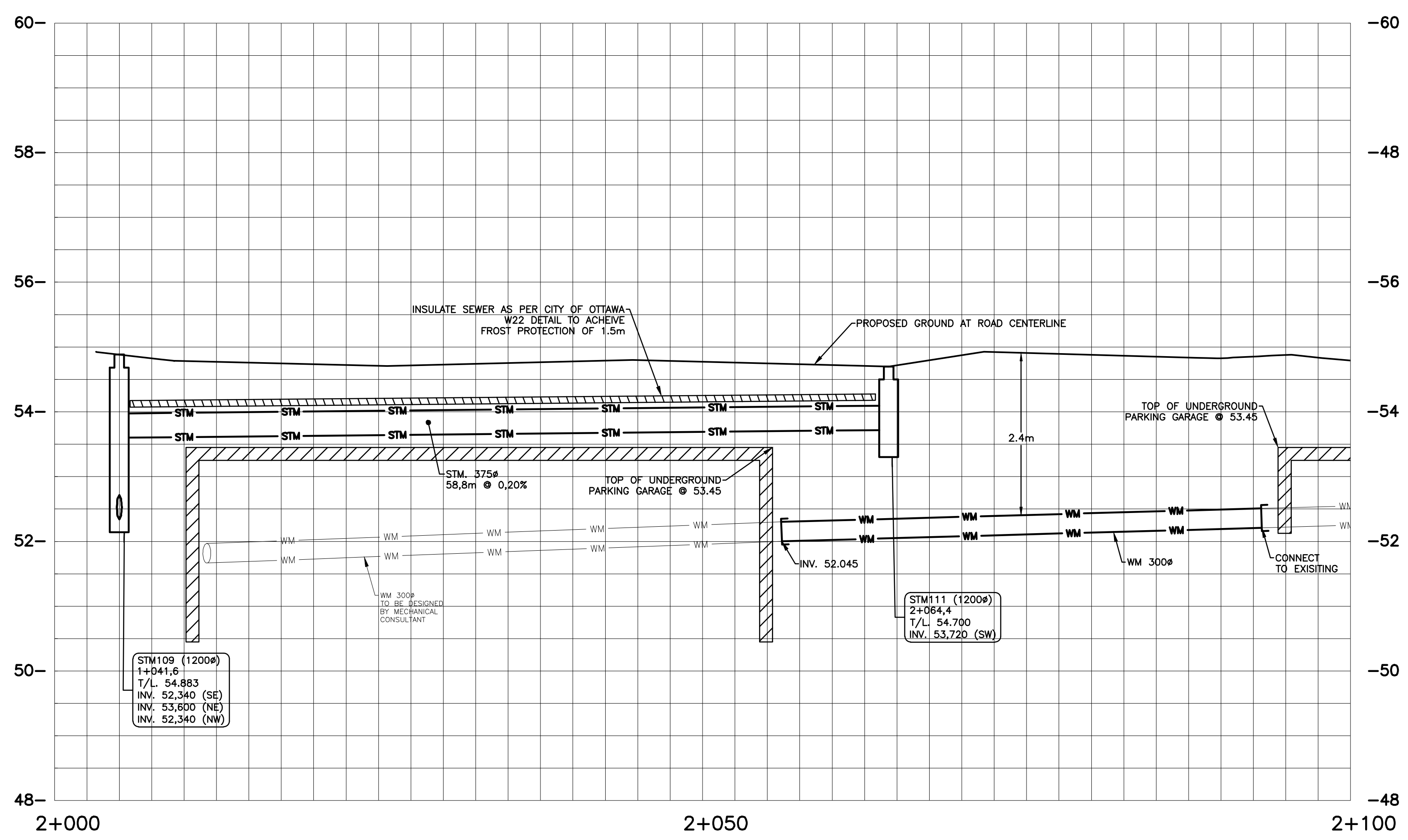
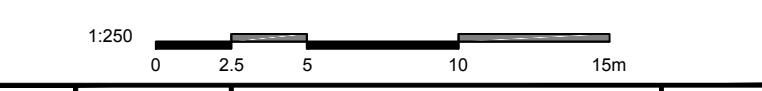

No.	Date	Description	By
2	AUG. 31, 2022	ISSUED FOR SITE PLAN APPLICATION	A.C.
1	APR. 18, 2022	ISSUED FOR SITE PLAN APPLICATION	A.C.

STAMPS:

DESIGNED BY: J.A. SAUVE
 APPROVED BY: A. CHAUMONT

ENGINEER:

CLIENT:
DREAM UNLIMITED
 30 ADELAIDE STREET EAST
 SUITE 301
 TORONTO, ON, M5C 3H1

ZIBI (Project Address)
 310 Miwate Private
 OTTAWA, ONTARIO
 K1R 0E1

PROJECT NAME:
**ZIBI ONTARIO
 BLOCK 204
 315 PRIVE MIWATE PRIVATE,
 CHAUDIERE ISLAND
 OTTAWA, ONTARIO**

SHEET TITLE:
**PLAN AND PROFILE
 STA. 2+000 TO 2+100**

DISCIPLINE:
CIVIL

DRAWER: S.C. POGGIOLI	SCALE: H=1:250 V=1:50
DESIGNER: J. SAUVE	DATE: 2022/03/14
APPROVER: A. CHAUMONT	APPROVER: A. CHAUMONT
PROJECT NO.: A000931	DRAWING NO.: C006B
SHEET NO.: 9 of 11	

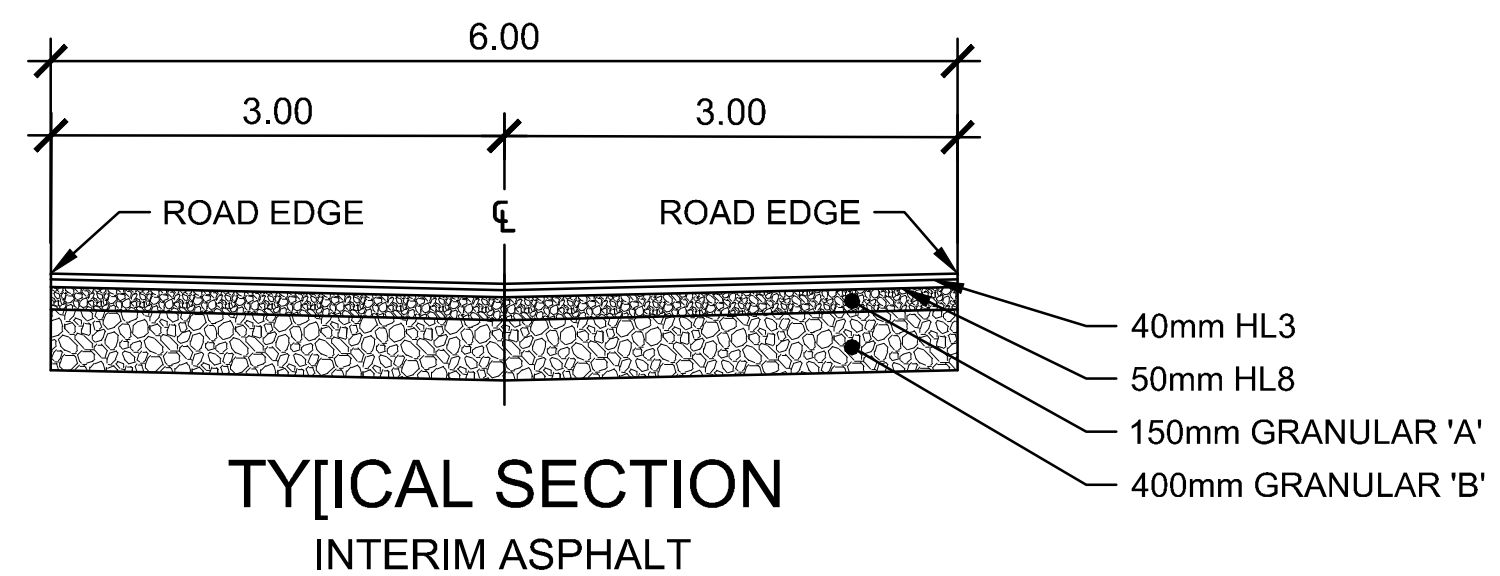
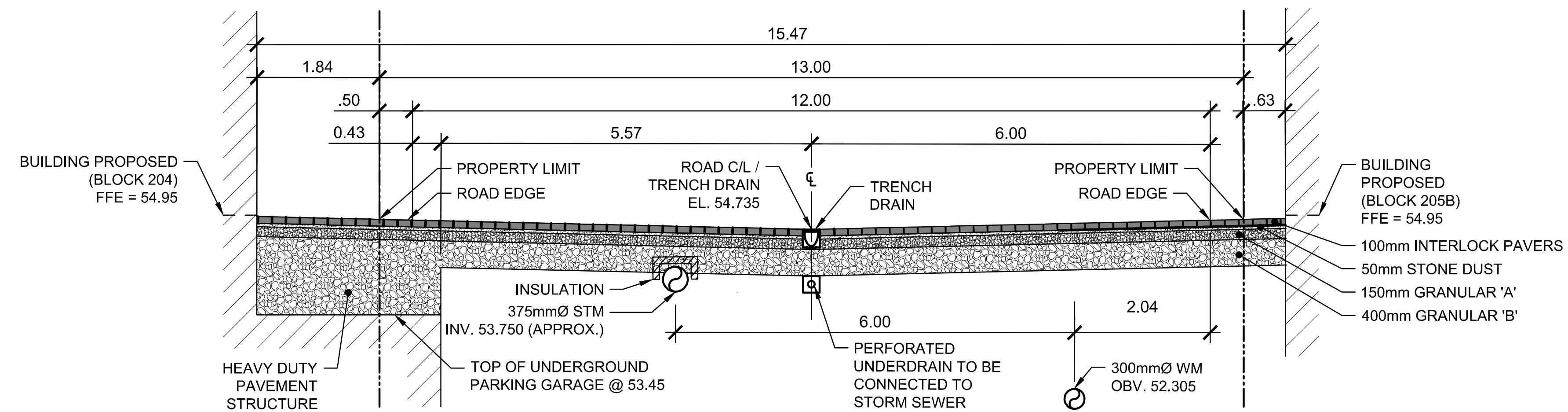
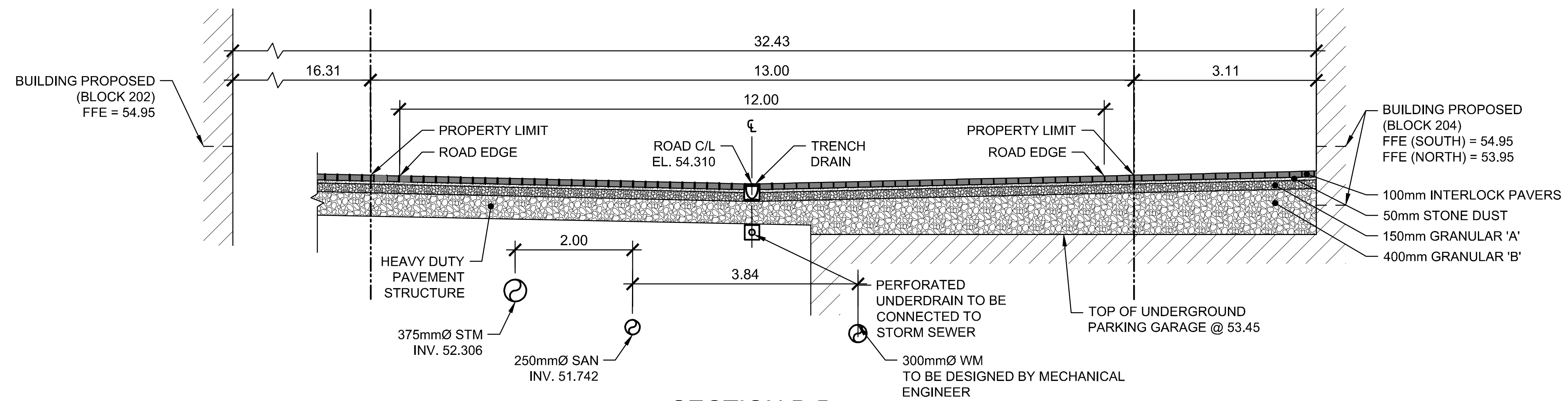
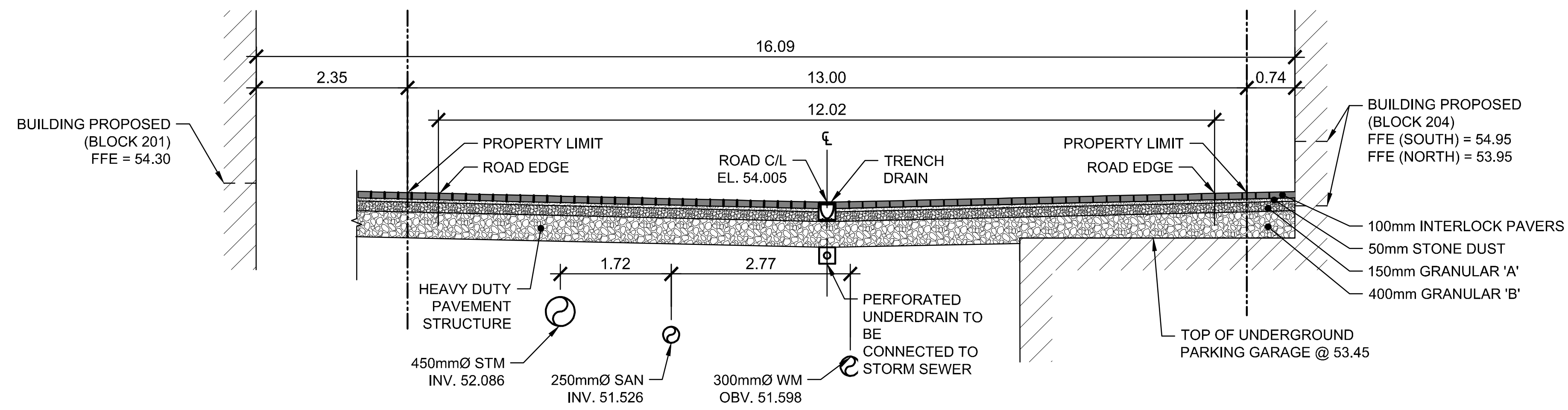

No.	Date	Description	By
2	AUG. 31, 2022	ISSUED FOR SITE PLAN APPLICATION	A.C.
1	APR. 18, 2022	ISSUED FOR SITE PLAN APPLICATION	A.C.

STAMPS:

DESIGNED BY: J.A. SAUVE
APPROVED BY: A. CHAUMONT

ENGINEER:

CLIENT:
DREAM UNLIMITED
30 ADELAIDE STREET EAST
SUITE 301
TORONTO, ON, M5C 3H1

ZIBI (Project Address)
310 Mivatte Private
OTTAWA, ONTARIO
K1R 0E1

PROJECT NAME:
ZIBI ONTARIO
BLOCK 204
315 PRIVE MIWATE PRIVATE,
CHAUDIERE ISLAND
OTTAWA, ONTARIO

SHEET TITLE:
TYPICAL CROSS SECTIONS

DISCIPLINE: CIVIL

DRAWER: S.C. POGGIOLI	SCALE: 1:50
DESIGNER: J. SAUVE	DATE: 2022/03/14
APPROVER: A. CHAUMONT	APPROVER: A. CHAUMONT
PROJECT NO: A000931	DRAWING NO: C007
SHEET NO: 10 of 11	

F

Appendix F ECA Application



ENVIRONMENTAL COMPLIANCE APPROVALNUMBER 1505-B96UCV
Issue Date: February 26, 2019

Windmill Dream ON Holdings LP Inc., as general partner
for and on behalf of Windmill Dream ON Holdings LP
6 Booth Street
Ottawa, Ontario
K1R 6K8

Site Location: Zibi Ontario Phase 1 (Domtar Lands Redevelopment, Phase
1)
Chaudiere Island
3 and 4 Booth Street
City of Ottawa
K1R 7W1

*You have applied under section 20.2 of Part II.1 of the Environmental Protection Act, R.S.O. 1990, c. E. 19
(Environmental Protection Act) for approval of:*

establishment of Storm and Sanitary sewage works to serve proposed Domtar Lands Redevelopment, Phase 1,
located on Chaudiere Island, to serve 1.09 ha of retail, commercial and office space and approximately 71
residential units, comprising;

A. Storm Sewers and Sanitary Sewers

- storm sewers to be constructed on Zibi Ontario Phase 1, receiving the storm flow from the temporary parking lot, block 301 and private roads, to be constructed on Perley and Booth Street, having diameter varying from 450mm to 600mm, from west Chaudiere Island, ultimately discharging to Ottawa River, through a proposed Oil/Grit Separator installed at MH STM102, located in the Booth Street right of way;
- sanitary sewers to be constructed on Zibi Ontario Phase 1, receiving the sanitary sewage flow from blocks 205A, 208, existing buildings on Albert Island, and existing Power House building, to be

constructed on Booth Street and Head Street, having 250mm diameter, from Parking area north of Electric Channel to a proposed interim Pumping Station at the existing building 535 Head Street;

- sanitary sewers to be constructed on Zibi Ontario Phase 1, receiving the sanitary sewage flow from future development, to be constructed on Perley Street and Booth Street, having 250mm diameter, from MH SAN 106 to MH SAN102, ultimately discharging to a proposed interim Pumping Station at the existing building 535 Head Street;

B. Pumping Station (interim) and Forcemain

- an interim pumping station located at existing building 535 Head Street, for the transmission of sanitary sewage from approximately 1.09 hectare area through sanitary sewers, located on Booth Street, Head Street and Perley Street, receiving the sewage flow from residential, retail and office units on the proposed in Zibi Ontario Phase 1 development, having a firm rated capacity of 13 L/s under a total dynamic head of 15.8m, discharging through a twin forcemain discharging ultimately to City of Ottawa Interceptor Sewer within Albert Street right of way;
- a twin forcemain located on Chaudiere Island, Booth Street, Fleet Street and Lloyd Street, receiving sanitary sewage flow from an interim pumping station, to a proposed sanitary manholes on the north side of the LRT Tunnel and ultimately to City of Ottawa Interceptor Sewer within Albert Street right of way;

C. Oil/Grit Separator

- one (1) oil/grit separator, located on the Booth Street right of way, designed for a stormwater drainage area of approximately 1.34 ha, upstream of headwall H100, having a maximum sediment storage capacity of 16,490 litres, recommended maintenance sediment volume of 3,038 Litres, an oil storage capacity of 3,360 Litres, a total holding capacity of 20,255 Litres and a maximum treatment flow rate of 50 litres per second, discharging ultimately to Ottawa River via a 600 millimetres diameter outlet pipe and a headwall;

including all other mechanical system, electrical system, instrumentation and control system, standby power system, piping, pumps, valves and appurtenances essential for the proper, safe and reliable operation of the Works in accordance with this Approval, in the context of process performance and general principles of wastewater engineering only;

all in accordance with the submitted supporting documents listed in Schedule A.

For the purpose of this environmental compliance approval, the following definitions apply:

1. "Approval " means this entire document and any schedules attached to it, and the application;
2. "BOD5 "(also known as TBOD₅) means five day biochemical oxygen demand measured in an unfiltered sample and includes carbonaceous and nitrogenous oxygen demand;

3. "*Director* " means a person appointed by the *Minister* pursuant to section 5 of the *EPA* for the purposes of Part II.1 of the *EPA*;
4. "*District Manager* " means the *District Manager* of the appropriate local *District Office* of the *Ministry*, where the *Works* are geographically located;
5. "*E. coli*" refers to the thermally tolerant forms of *Escherichia* that can survive at 44.5 degrees Celsius;
6. "*EPA* " means the Environmental Protection Act, R.S.O. 1990, c.E.19, as amended;
7. "*Emergency Situation* " means a structural, mechanical or electrical failure that causes a temporary reduction in the capacity of the *Sewage Pumping Station* or an unforeseen flow condition that may result in:
 1. a danger to the health or safety of any person; or
 2. injury or damage to any property, or serious risk of injury or damage to any property;
8. "*Equivalent Equipment* " means a substituted equipment or like-for-like equipment that meets the required quality and performance standards of a named equipment;
9. "*Event* " means an action or occurrence at the *Sewage Pumping Station* that causes a *Sewage Pumping Station Overflow* . An *Event* ends when there is no recurrence of a *Sewage Pumping Station Overflow* in the 12-hour period following the last *Sewage Pumping Station Overflow* . Two *Events* are separated by at least 12 hours during which there has been no recurrence of a *Sewage Pumping Station Overflow*;
10. "*Limited Operational Flexibility* " (LOF) means any modifications that the *Owner* is permitted to make to the *Works* under this *Approval*;
11. "*Ministry* " means the ministry of the government of Ontario responsible for the *EPA* and *OWRA* and includes all officials, employees or other persons acting on its behalf;
12. "*Notice of Modifications* " means the form entitled "Notice of Modification to Sewage Works";
13. "*Owner* " means Windmill Dream ON Holdings LP, and includes its successors and assignees;
14. "*OWRA* " means the Ontario Water Resources Act, R.S.O. 1990, c. O.40, as amended;
15. "*Professional Engineer* " means a person entitled to practice as a *Professional Engineer* in the Province of Ontario under a licence issued under the Professional Engineers Act;

16. "*Sewage Pumping Station Overflow* " means any discharge from a Sewage Pumping Station to the environment that does not undergo any treatment or only receives partial treatment before it is discharged to the environment;
17. "*Substantial Completion* " has the same meaning as “substantial performance” in the Construction Lien Act;
18. "*Works* " means the sewage works described in the Owner’s application, this *Approval*, and the modifications made under *Limited Operational Flexibility*.

You are hereby notified that this environmental compliance approval is issued to you subject to the terms and conditions outlined below:

TERMS AND CONDITIONS

1. GENERAL CONDITIONS

1. The *Owner* shall ensure that any person authorized to carry out work on or operate any aspect of the *Works* is notified of this *Approval* and the conditions herein and shall take all reasonable measures to ensure any such person complies with the same.
2. Except as otherwise provided by these Conditions, the *Owner* shall design, build, install, operate and maintain the *Works* in accordance with the description given in this *Approval*, and the application for approval of the *Works*.
3. Where there is a conflict between a provision of any document in the schedule referred to in this *Approval* and the conditions of this *Approval*, the conditions in this *Approval* shall take precedence, and where there is a conflict between the documents in the schedule, the document bearing the most recent date shall prevail.
4. Where there is a conflict between the documents listed in Schedule ‘A’ and the application, the application shall take precedence unless it is clear that the purpose of the document was to amend the application.
5. The conditions of this *Approval* are severable. If any condition of this *Approval*, or the application of any requirement of this *Approval* to any circumstance, is held invalid or unenforceable, the application of such condition to other circumstances and the remainder of this *Approval* shall not be affected thereby.

2. EXPIRY OF APPROVAL

1. This *Approval* will cease to apply to those parts of the *Work* which have not been constructed within five (5) years of the date of this *Approval*.

2. In the event that completion and commissioning of any portion of the *Works* is anticipated to be delayed beyond the specified expiry period, the *Owner* shall submit an application of extension to the expiry period, at least twelve (12) months prior to the end of the period. The application for extension shall include the reason(s) for the delay, whether there is any design change(s) and a review of whether the standards applicable at the time of *Approval* of the *Works* are still applicable at the time of request for extension, to ensure the ongoing protection of the environment.
3. This Approval for the interim Works (interim sewage pumping station) shall expire and become null and void on March 31, 2024

3. CHANGE OF OWNER

1. The *Owner* shall notify the *District Manager* and the *Director*, in writing, of any of the following changes within thirty (30) days of the change occurring:
 - a. change of *Owner*;
 - b. change of address of the *Owner*;
 - c. change of partners where the *Owner* is or at any time becomes a partnership, and a copy of the most recent declaration filed under the Business Names Act, R.S.O. 1990, c.B17 shall be included in the notification to the *District Manager*; or
 - d. change of name of the corporation where the *Owner* is or at any time becomes a corporation, and a copy of the most current information filed under the Corporations Information Act, R.S.O. 1990, c. C39 shall be included in the notification to the *District Manager*.
2. In the event of any change in ownership of the *Works*, other than a change to a successor municipality, the *Owner* shall notify in writing the succeeding owner of the existence of this *Approval*, and a copy of such notice shall be forwarded to the *District Manager* and the *Director*.
3. The *Owner* shall ensure that all communications made pursuant to this condition refer to the number at the top of this *Approval*.
4. Notwithstanding any other requirements in this *Approval*, upon transfer of the ownership or assumption of the Works to a municipality if applicable, any reference to the *District Manager* shall be replaced with the *Water Supervisor*.

4. UPON THE SUBSTANTIAL COMPLETION OF THE WORKS

1. Upon the Substantial Completion of the *Works*, the *Owner* shall prepare a statement, certified by a *Professional Engineer*, that the works are constructed in accordance with this *Approval*, and

upon request, shall make the written statement available for inspection by *Ministry* personnel.

2. Within six (6) months of the *Substantial Completion* of the *Works*, a set of as-built drawings showing the works “as constructed” shall be prepared. These drawings shall be kept up to date through revisions undertaken from time to time and a copy shall be retained at the *Works* for the operational life of the *Works*.

5. SEWAGE PUMPING STATION OVERFLOW

1. Any *Sewage Pumping Station Overflow* is prohibited, except:
 - a. in an *Emergency Situation*; and
 - b. where the *Sewage Pumping Station Overflow* is a direct and unavoidable result of a planned maintenance procedure, the *Owner* having notified the *District Manager* at least fifteen (15) days prior to the occurrence of the *Sewage Pumping Station Overflow* and the *District Manager* having given written consent of the *Sewage Pumping Station Overflow*.
2. The *Owner* shall forthwith notify the Spills Action Centre (SAC) and the Medical Officer of Health of all *Events* as soon as possible. This notice shall include, at a minimum, the following information:
 - a. the date, time, and duration of the *Event*;
 - b. the location of the *Sewage Pumping Station Overflow* and the receiver;
 - c. the measured or estimated volume of the *Event* (unless the *Event* is ongoing); and
 - d. the reason for the *Event*.
3. The *Owner* shall submit a summary report of the *Sewage Pumping Station Overflow Events* to the *District Manager* on a quarterly basis, no later than each of the following dates for each calendar year: February 14, May 15, August 14, and November 15. The summary reports shall be in a format specified by the *Ministry*, which shall include, at a minimum, the following information on any *Events* that occurred during the preceding quarter:
 - a. the date of the *Event(s)*;
 - b. the measured or estimated volume of the *Event(s)*;
 - c. the duration of the *Event(s)*;
 - d. the location of the *Sewage Pumping Station Overflow* and the receiver;

- e. the reason for the *Event(s)*; and
 - f. the impact of the *Event(s)* on the receiver(s).
4. The *Owner* shall use best efforts to collect a representative sample consisting of a minimum of two (2) grab samples of the *Sewage Pumping Station Overflow* and have it analyzed for the parameters outlined in Condition 7 using the protocols specified in Condition 7, one at the beginning of the *Event* and the second approximately near the end of the *Event*, to best reflect the effluent quality of the *Sewage Pumping Station Overflow*.
 5. The *Owner* shall maintain a logbook of all *Sewage Pumping Station Overflows*, which shall contain, at a minimum, the types of information set out in sub-conditions 2(a) to 2(d) in respect of each *Sewage Pumping Station Overflow*.

6. OPERATION AND MAINTENANCE OF PUMPING STATION AND FORCEMAINS

1. The *Owner* shall exercise due diligence in ensuring that, at all times, the *Works* and the related equipment and appurtenances used to achieve compliance with this *Approval* are properly operated and maintained. Proper operation and maintenance shall include effective performance, adequate funding, adequate operator staffing and training, including training in all procedures and other requirements of this *Approval* and the *EPA* and regulations, adequate laboratory facilities, process controls and alarms and the use of process chemicals and other substances used in the *Works*.
2. The *Owner* shall prepare an operations manual prior to the commencement of operation of the *Works*, that includes, but is not necessarily limited to, the following information:
 - a. operating and maintenance procedures for routine operation of the *Works*;
 - b. inspection programs, including frequency of inspection, for the *Works* and the methods or tests employed to detect when maintenance is necessary;
 - c. repair and maintenance programs, including the frequency of repair and maintenance for the *Works*;
 - d. procedures for the inspection and calibration of monitoring equipment;
 - e. a spill prevention control and countermeasures plan, consisting of contingency plans and procedures for dealing with equipment breakdowns, potential spills and any other abnormal situations, including notification to the Spills Action Centre (SAC), the Medical Officer of Health, and the *District Manager*; and
 - f. procedures for receiving, responding and recording public complaints, including recording any follow-up actions taken.

3. The *Owner* shall maintain the operations manual current and retain a copy at the location of the *Works* for the operational life of the *Works*. Upon request, the *Owner* shall make the manual available to *Ministry* staff.
4. The *Owner* shall provide for the overall operation of the *Works* an operator who holds a licence that is applicable to that type of facility and that is of the same class as or higher than the class of the facility in accordance with Ontario Regulation 129/04.

7. OPERATION AND MAINTENANCE OF STORMWATER WORKS

1. If applicable, any proposed storm sewers or other stormwater conveyance in this Approval can be constructed but not operated until the proposed stormwater management facilities in this Approval or any other Approval that are designed to service the storm sewers or other stormwater conveyance are in operation.
2. The Owner shall make all necessary investigations, take all necessary steps and obtain all necessary approvals so as to ensure that the physical structure, siting and operations of the Works do not constitute a safety or health hazard to the general public. ..
3. The Owner shall undertake an inspection of the condition of the Works, at least once a year, and undertake any necessary cleaning and maintenance to ensure that sediment, debris and excessive decaying vegetation are removed from the Works to prevent the excessive build-up of sediment, oil/grit, debris and/or decaying vegetation, to avoid reduction of the capacity and/or permeability of the Works, as applicable. The Owner shall also regularly inspect and clean out the inlet to and outlet from the Works to ensure that these are not obstructed.
4. The Owner shall construct, operate and maintain the Works with the objective that the effluent from the Works is essentially free of floating and settleable solids and does not contain oil or any other substance in amounts sufficient to create a visible film, sheen, foam or discoloration on the receiving waters.
5. The Owner shall maintain a logbook to record the results of these inspections and any cleaning and maintenance operations undertaken, and shall keep the logbook at the Owner's administrative office for inspection by the Ministry. The logbook shall include the following:
 - a. the name of the Works; and
 - b. the date and results of each inspection, maintenance and cleaning, including an estimate of the quantity of any materials removed and method of clean-out of the Works.
6. The Owner shall prepare an operations manual prior to the commencement of operation of the Works that includes, but is not necessarily limited to, the following information:
 - a. operating and maintenance procedures for routine operation of the Works;

- b. inspection programs, including frequency of inspection, for the Works and the methods or tests employed to detect when maintenance is necessary;
 - c. repair and maintenance programs, including the frequency of repair and maintenance for the Works;
 - d. contingency plans and procedures for dealing with potential spills and any other abnormal situations and for notifying the District Manager; and
 - e. procedures for receiving, responding and recording public complaints, including recording any follow-up actions taken.
7. The Owner shall maintain the operations manual current and retain a copy at the Owner's administrative office for the operational life of the Works. Upon request, the Owner shall make the manual available to Ministry staff.

8. MONITORING AND RECORDING

The *Owner* shall, upon commencement of operation of the *Works*, carry out the following monitoring program:

1. All samples and measurements taken for the purposes of this *Approval* are to be taken at a time and in a location characteristic of the quality and quantity of the *Sewage Pumping Station Overflow* stream over the time period being monitored.
2. Samples shall be collected at the following sampling points, at the frequency specified, by means of the specified sample type and analyzed for each parameter listed and all results recorded, seen in Schedule C.
3. The methods and protocols for sampling, analysis and recording shall conform, in order of precedence, to the methods and protocols specified in the following:
 - a. the *Ministry's* Procedure F-10-1, "Procedures for Sampling and Analysis Requirements for Municipal and Private Sewage Treatment Works (Liquid Waste Streams Only)", as amended from time to time by more recently published editions;
 - b. the *Ministry's* publication "Protocol for the Sampling and Analysis of Industrial/Municipal Wastewater" (January 1999), ISBN 0-7778-1880-9, as amended from time to time by more recently published editions; and
 - c. the publication "Standard Methods for the Examination of Water and Wastewater" (21st edition), as amended from time to time by more recently published editions.

9. TEMPORARY EROSION AND SEDIMENT CONTROL

1. The Owner shall install and maintain temporary sediment and erosion control measures during construction and conduct inspections once every two (2) weeks and after each significant storm event (a significant storm event is defined as a minimum of 25 millimetres of rain in any 24 hours period). The inspections and maintenance of the temporary sediment and erosion control measures shall continue until they are no longer required and at which time they shall be removed and all disturbed areas reinstated properly.
2. The Owner shall maintain records of inspections and maintenance which shall be made available for inspection by the Ministry, upon request. The record shall include the name of the inspector, date of inspection, and the remedial measures, if any, undertaken to maintain the temporary sediment and erosion control measures.

10. REPORTING

1. One (1) week prior to the start-up of the operation of the *Works*, the *Owner* shall notify the *District Manager* (in writing) of the pending start-up date.
2. The *Owner* shall, upon request, make all manuals, plans, records, data, procedures and supporting documentation available to *Ministry* staff.
3. The *Owner* shall prepare and submit a performance report to the *District Manager* on an annual basis, within ninety (90) days following the end of the period being reported upon. The first such report shall cover the first annual period following the commencement of operation of the *Works* and subsequent reports shall be submitted to cover successive annual periods following thereafter. The reports shall contain, but shall not be limited to, the following information:
 - a. a summary and interpretation of all monitoring data, including an overview of the success and adequacy of the *Works*;
 - b. a description of any operating problems encountered and corrective actions taken;
 - c. a summary of all maintenance carried out on any major structure, equipment, apparatus, mechanism or thing forming part of the *Works*;
 - d. a summary of the calibration and maintenance carried out on all monitoring equipment;
 - e. a summary of any complaints received during the reporting period and any steps taken to address the complaints;
 - f. a summary of all *Sewage Pumping Station Overflows*, spill or abnormal discharge events;

- g. a copy of all *Notice of Modifications* submitted to the *District Manager* as a result of Schedule B, Section 1, with a status report on the implementation of each modification;
 - h. a report summarizing all modifications completed as a result of Schedule B, Section 3; and
 - i. any other information the *District Manager* requires from time to time.
4. The *Owner* shall, within thirty (30) calendar days of issuance of this *Approval*, submit a Municipal Wastewater System Profile Information Form, and shall resubmit the updated document every time a notification is provided to the *District Manager* in compliance with requirements of change of ownership under this *Approval*.

11. LIMITED OPERATIONAL FLEXIBILITY

1. The *Owner* may make modifications to the *Works* in accordance with the Terms and Conditions of this *Approval* and subject to the *Ministry's* "Limited Operational Flexibility Criteria for Modifications to Sewage Works", included under Schedule B of this *Approval*, as amended.
2. Sewage works proposed under *Limited Operational Flexibility* shall adhere to the design guidelines contained within the *Ministry's* publication "Design Guidelines for Sewage Works 2008", as amended.
3. The *Owner* shall ensure at all times, that the *Works*, related equipment and appurtenances which are installed or used to achieve compliance are operated in accordance with all Terms and Conditions of this *Approval*.
4. For greater certainty, the following are not permitted as part of *Limited Operational Flexibility*:
 - a. modifications to the *Works* that result in an increase of the approved Rated Capacity of the *Works*;
 - b. modifications to the *Works* that may adversely affect the approved effluent quality criteria or the location of the discharge/outfall;
 - c. modifications to the treatment process technology of the *Works*, or modifications that involve construction of new reactors (tanks) or alter the treatment train process design;
 - d. modifications to the *Works* approved under s.9 of the *EPA*; and
 - e. modifications to the *Works* pursuant to an order issued by the *Ministry*.
5. Implementation of *Limited Operational Flexibility* is not intended to be used for piecemeal measures that result in major alterations or expansions.
6. If the implementation of *Limited Operational Flexibility* requires changes to be made to the

Emergency Response, Spill Reporting and Contingency Plan, the *Owner* shall, as deemed necessary in consultation with the *District Manager*, provide a revised copy of this plan to the local fire services authority prior to implementing *Limited Operational Flexibility*.

7. For greater certainty, any modification made under the *Limited Operational Flexibility* may only be carried out after other legal obligations have been complied with, including those arising from the Environmental Protection Act, Niagara Escarpment Planning and Development Act, Oak Ridges Moraine Conservation Act, Lake Simcoe Protection Act and Greenbelt Act.
8. Prior to implementing *Limited Operational Flexibility*, the *Owner* shall complete a *Notice of Modifications* describing any proposed modifications to the *Works* and submit it to the *District Manager*.

Schedule A

1. Application for Environmental Compliance Approval December 20, 2018 and received on December 24, 2018, including design report, final plans and specifications.

Schedule B

Limited Operational Flexibility

Protocol for Pre-Authorized Modifications to Municipal Sewage Works - Pumping Station

1. General

1. Pre-authorized modifications are permitted only where Limited Operational Flexibility has already been granted in the Approval and only permitted to be made at the pumping stations in the Works, subject to the conditions of the Approval.
 2. Where there is a conflict between the types and scope of pre-authorized modifications listed in this document, and the Approval where Limited Operational Flexibility has been granted, the Approval shall take precedence.
 3. The Owner shall consult the District Manager on any proposed modifications that may fall within the scope and intention of the Limited Operational Flexibility but is not listed explicitly or included as an example in this document.
 4. The Owner shall ensure that any pre-authorized modifications will not:
 - a. adversely affect the hydraulic profile of the sanitary sewage system;
 - b. result in new Overflow locations, or any potential increase in frequency or quantity of Overflow.
2. Modifications that do not require pre-authorization:
1. Sewage works that are exempt from Ministry approval requirements;
 2. Modifications to the electrical system, instrumentation and control system.
3. Pre-authorized modifications that do not require preparation of “Notice of Modification to Sewage Works”
1. Normal or emergency maintenance activities, such as repairs, renovations, refurbishments and replacements with Equivalent Equipment, or other improvements to an existing approved piece of equipment of a treatment process do not require pre-authorization. Examples of these activities are:
 - a. Repairing a piece of equipment and putting it back into operation, including replacement of

- minor components such as belts, gear boxes, seals, bearings;
- b. Repairing a piece of equipment by replacing a major component of the equipment such as motor, with the same make and model or another with the same or very close power rating but the capacity of the pump or blower will still be essentially the same as originally designed and approved;
 - c. Replacing the entire piece of equipment with Equivalent Equipment.
2. Improvements to equipment efficiency or treatment do not require pre-authorization. Examples of these activities are:
- a. Adding variable frequency drive to pumps;
 - b. Adding flow measurement or other control device.
4. Pre-Authorized Modifications that require preparation of “Notice of Modification to Sewage Works”
1. Pumping Stations
 - a. Replacement, realignment of existing sewers including manholes, valves, gates, weirs and associated appurtenances provided that the modifications will not add new influent source(s) or result in an increase in flow from existing sources as originally approved.
 - b. Extension or partition of wetwell to increase retention time for emergency response and improve station maintenance and pump operation;
 - c. Replacement or installation of inlet screens to the wetwell;
 - d. Replacement or installation of flowmeters, construction of station bypass;
 - e. Replacement, reconfiguration or addition of pumps and modifications to pump suction and discharge pipings provided that the modifications will not result in a reduction in the firm pumping capacity or discharge head or an increase in the peak pumping rate of the pumping station as originally designed;
 - f. Replacement, realignment of existing forcemain(s) including valves, gates, and associated appurtenances provided that the modifications will not reduce the flow capacity or increase the total dynamic head and transient in the forcemain.
 2. Chemical Systems in Pumping Stations
 - a. Replacement and relocation of chemical storage tanks for existing chemical systems only, provided that the tanks are sited with effective spill containment;

- b. Replacement of existing chemical dosing pumps provided that the modifications will not result in a reduction in the firm capacity that the dosing pumps are originally designed to handle.
 - c. Use of an alternate chemical provided that it is a non-proprietary product and is a commonly used alternative to the chemical approved in the Works, provided that the existing chemical storage tanks, chemical dosing pumps, feed pipes and controls are also upgraded, as necessary.
3. Standby Power System
- a. Replacement or installation of standby power system, including feed from alternate power grid, emergency power generator, fuel supply and storage systems, provided that the existing standby power generation capacity is not reduced.

This page contains an image of the form entitled "Notice of Modification to Sewage Works". A digital copy can be obtained from the District Manager.



Ministry of the Environment, Conservation and Parks

Notice of Modification to Sewage Works

RETAIN COPY OF COMPLETED FORM AS PART OF THE ECA ON-SITE PRIOR TO THE SCHEDULED IMPLEMENTATION DATE.

Part 1 – Environmental Compliance Approval (ECA) with Limited Operational Flexibility		
<i>(Insert the ECA's owner, number and issuance date and notice number, which should start with "01" and consecutive numbers thereafter)</i>		
ECA Number	Issuance Date (mm/dd/yy)	Notice number (if applicable)
ECA Owner		Municipality

Part 2: Description of the modifications as part of the Limited Operational Flexibility
<i>(Attach a detailed description of the sewage works)</i>
<p>Description shall include:</p> <ol style="list-style-type: none"> 1. A detail description of the modifications and/or operations to the sewage works (e.g. sewage work component, location, size, equipment type/model, material, process name, etc.) 2. Confirmation that the anticipated environmental effects are negligible. 3. List of updated versions of, or amendments to, all relevant technical documents that are affected by the modifications as applicable, i.e. submission of documentation is not required, but the listing of updated documents is (design brief, drawings, emergency plan, etc.)

Part 3 – Declaration by Professional Engineer				
<p>I hereby declare that I have verified the scope and technical aspects of this modification and confirm that the design:</p> <ol style="list-style-type: none"> 1. Has been prepared or reviewed by a Professional Engineer who is licensed to practice in the Province of Ontario; 2. Has been designed in accordance with the Limited Operational Flexibility as described in the ECA; 3. Has been designed consistent with Ministry's Design Guidelines, adhering to engineering standards, industry's best management practices, and demonstrating ongoing compliance with s.53 of the Ontario Water Resources Act; and other appropriate regulations. <p>I hereby declare that to the best of my knowledge, information and belief the information contained in this form is complete and accurate</p>				
<table border="1"> <tr> <td>Name (Print)</td> <td>PEO License Number</td> </tr> <tr> <td>Signature</td> <td>Date (mm/dd/yy)</td> </tr> </table>	Name (Print)	PEO License Number	Signature	Date (mm/dd/yy)
Name (Print)	PEO License Number			
Signature	Date (mm/dd/yy)			
Name of Employer				

Part 4 – Declaration by Owner				
<p>I hereby declare that:</p> <ol style="list-style-type: none"> 1. I am authorized by the Owner to complete this Declaration; 2. The Owner consents to the modification; and 3. This modifications to the sewage works are proposed in accordance with the Limited Operational Flexibility as described in the ECA. 4. The Owner has fulfilled all applicable requirements of the <i>Environmental Assessment Act</i>. <p>I hereby declare that to the best of my knowledge, information and belief the information contained in this form is complete and accurate</p>				
<table border="1"> <tr> <td>Name of Owner Representative (Print)</td> <td>Owner representative's title (Print)</td> </tr> <tr> <td>Owner Representative's Signature</td> <td>Date (mm/dd/yy)</td> </tr> </table>	Name of Owner Representative (Print)	Owner representative's title (Print)	Owner Representative's Signature	Date (mm/dd/yy)
Name of Owner Representative (Print)	Owner representative's title (Print)			
Owner Representative's Signature	Date (mm/dd/yy)			

EAPB Form July 26, 2018

Schedule C

Table 1 - Monitoring during a Sewage Pumping Station Overflow Event

(Samples to be collected from the Sewage Pumping Station Overflow stream)

Sample Type	Grab
Frequency	One sample at the beginning of the Event and the second sample approximately near the end of the Event
Parameters	BOD5, Total Suspended Solids, Total Phosphorus, Total Ammonia Nitrogen, E. coli (Note 1 see below), and pH

Note 1: Sampling and analysis shall be performed only for Events that occur between April 1 and October 31 inclusive

The reasons for the imposition of these terms and conditions are as follows:

1. Condition 1 is imposed to ensure that the *Works* are constructed and operated in the manner in which they were described and upon which approval was granted. This condition is also included to emphasize the precedence of conditions in the *Approval* and the practice that the *Approval* is based on the most current document, if several conflicting documents are submitted for review.
2. Condition 2 is included to ensure that, when the *Works* are constructed, the *Works* will meet the standards that apply at the time of construction to ensure the ongoing protection of the environment.
3. Condition 3 is included to ensure that the *Ministry* records are kept accurate and current with respect to approved *Works* and to ensure that subsequent owners of the *Works* are made aware of the *Approval* and continue to operate the *Works* in compliance with it.
4. Condition 4 is included to ensure that the *Works* are constructed in accordance with the *Approval* and that record drawings of the *Works* “as constructed” are updated and maintained for future references.
5. Condition 5 is included to indicate that *Sewage Pumping Station Overflows* are prohibited, except in circumstances where the failure to overflow could result in greater injury to the public interest than the *Sewage Pumping Station Overflow* itself. The notification and documentation requirements allow the *Ministry* to take action in an informed manner and ensure that the *Owner* is aware of the extent and frequency of *Events*.
6. Condition 6 and 7 is included to ensure that the *Works* are properly operated, maintained, funded, staffed and equipped such that the environment is protected and deterioration, loss, injury or damage to any person or property is prevented. The Condition also ensures that a comprehensive operations manual governing all significant areas of operation, maintenance and repair is prepared, implemented and kept up-to-date by the *Owner* and is made available to the *Ministry*. Such a manual is an integral part of the operation of the *Works*. Its compilation and use should assist the *Owner* in staff training, proper plant operation, and identification and planning for contingencies during abnormal conditions. The manual will also act as a benchmark for *Ministry* staff when reviewing the operation of the *Works*.
7. Condition 8 is included to provide additional details on the monitoring of *Sewage Pumping Station Overflows*.
8. Condition 9 is included as installation, regular inspection and maintenance of the temporary sediment and erosion control measures is required to mitigate the impact on the downstream receiving watercourse during construction until they are no longer required.
9. Condition 10 is included to provide a performance record for future references, to ensure that the *Ministry* is made aware of problems as they arise, and to provide a compliance record for all the terms and conditions outlined in this *Approval*, so that the *Ministry* can work with the *Owner* in resolving any problems in a

timely manner.

10. Condition 11 is included to ensure that the *Works* are operated in accordance with the application and supporting documentation submitted by the *Owner*, and not in a manner which the *Director* has not been asked to consider. These conditions are also included to ensure that a *Professional Engineer* has reviewed the proposed modifications and attests that the modifications are in line with that of *Limited Operational Flexibility*, and provide assurance that the proposed modifications comply with the *Ministry's* requirements stipulated in the terms and conditions of this *Approval*, *Ministry* policies, guidelines, and industry engineering standards and best management practices.

In accordance with Section 139 of the Environmental Protection Act, you may by written Notice served upon me and the Environmental Review Tribunal within 15 days after receipt of this Notice, require a hearing by the Tribunal. Section 142 of the Environmental Protection Act provides that the Notice requiring the hearing shall state:

- a. The portions of the environmental compliance approval or each term or condition in the environmental compliance approval in respect of which the hearing is required, and;
- b. The grounds on which you intend to rely at the hearing in relation to each portion appealed.

The Notice should also include:

1. The name of the appellant;
2. The address of the appellant;
3. The environmental compliance approval number;
4. The date of the environmental compliance approval;
5. The name of the Director, and;
6. The municipality or municipalities within which the project is to be engaged in.

And the Notice should be signed and dated by the appellant.

This Notice must be served upon:

The Secretary*
Environmental Review Tribunal
655 Bay Street, Suite 1500
Toronto, Ontario
M5G 1E5

AND

The Director appointed for the purposes of
Part II.1 of the Environmental Protection Act
Ministry of the Environment,
Conservation and Parks
135 St. Clair Avenue West, 1st Floor
Toronto, Ontario
M4V 1P5

* Further information on the Environmental Review Tribunal's requirements for an appeal can be obtained directly from the Tribunal at: Tel: (416) 212-6349, Fax: (416) 326-5370 or www.ert.gov.on.ca

The above noted activity is approved under s.20.3 of Part II.1 of the Environmental Protection Act.

DATED AT TORONTO this 26th day of February, 2019

A handwritten signature in black ink that reads "Aziz Ahmed". The signature is written in a cursive style and is underlined with a single horizontal line.

Aziz Ahmed, P.Eng.

Director

appointed for the purposes of Part II.1 of the
Environmental Protection Act

KH/

c: District Manager, MECP Ottawa
Steven Merrick, David Schaeffer Engineering Ltd.

F

Appendix G Phase 1 (DSEL Report)



**FUNCTIONAL SERVICING AND
STORMWATER MANAGEMENT
REPORT**

FOR

**WINDMILL DEVELOPMENT GROUP
LTD.
DOMTAR LANDS
REDEVELOPMENT – PHASE 1**

CITY OF OTTAWA

PROJECT NO.: 14-717

**AUGUST 2018 – REV 4
© DSEL**

**FUNCTIONAL SERVICING AND STORMWATER MANAGEMENT REPORT
FOR
WINDMILL DEVELOPMENT GROUP LTD.
DOMTAR LANDS REDEVELOPMENT – PHASE 1**

AUGUST 2018 – REV 4

TABLE OF CONTENTS

1.0	INTRODUCTION	1
1.1	Existing Conditions	3
1.2	Required Permits / Approvals	4
1.3	Pre-consultation.....	4
2.0	GUIDELINES, PREVIOUS STUDIES, AND REPORTS.....	5
2.1	Existing Studies, Guidelines, and Reports.....	5
3.0	WATER SUPPLY SERVICING	7
3.1	Existing Water Supply Services	7
3.2	Water Supply Servicing Design	8
3.3	Water Modeling	9
3.4	Water Supply Conclusion	10
4.0	WASTEWATER SERVICING.....	11
4.1	Existing Wastewater Services	11
4.2	Wastewater Design	12
4.3	Wastewater Servicing Conclusion	13
5.0	STORMWATER MANAGEMENT	14
5.1	Existing Stormwater Services	14
5.2	Post-development Stormwater Management Targets	14
5.3	Stormwater Management System	14
5.4	Minor and Major System Flow	15
	5.4.1 Model Summary.....	15
	5.4.2 Model Results.....	16
5.5	Stormwater Servicing Conclusions	18
6.0	EROSION AND SEDIMENT CONTROL	19

7.0	UTILITIES.....	20
8.0	CONCLUSION AND RECOMMENDATIONS	21

FIGURES

Figure 1 Site Location

TABLES

Table 1 Water Supply Design Criteria
Table 2 Water Demand - Historical Site Conditions
Table 3 Water Demand – Proposed Site Conditions
Table 4 Model Simulation Output Summary – Phase 1
Table 5 Wastewater Design Criteria
Table 6 Summary of Anticipated Wastewater Discharge
Table 7 Summary of Minor and Major System Flow, 4 Hour Chicago Storm
Distribution

APPENDICES

Appendix A Servicing Check List / Pre-consultation
Appendix B Water Supply Calculations
Appendix C Wastewater Collection Calculations
Appendix D Stormwater Management Calculations
Drawings / Figures

**FUNCTIONAL SERVICING AND STORMWATER MANAGEMENT REPORT
FOR
WINDMILL DEVELOPMENT GROUP LTD.
DOMTAR LANDS REDEVELOPMENT – PHASE 1**

CITY OF OTTAWA

AUGUST 2018 – REV 4

PROJECT NO.: 14-717

1.0 INTRODUCTION

David Schaeffer Engineering Ltd. (DSEL) has been retained to prepare a Functional Servicing and Stormwater Management Report (FSR) for the proposed Domtar Lands Redevelopment, henceforth referred to as Zibi Ontario, in support of Windmill Development Group's application for Site Plan Control (SPC) for Phase 1 of the development.

The subject property consists of lands within the City of Ottawa urban boundary. The applicant also owns lands within Gatineau, Quebec that are planned to be designed and constructed concurrently with the proposed development within Ottawa, Ontario. The Ontario and Quebec developments will be serviced independently, the following FSR is solely in support of the Phase 1 of the Ontario Site.

As illustrated in **Figure 1**, the subject property is located on parts of Chaudière and Albert Islands within the Ottawa River, and it is accessible via Booth Street and the Chaudière Bridge. The following FSR is to support the development of Phase 1 only, as indicated in **Figure 1**, which measures approximately **1.09 ha**. Phase 1 is generally bounded by Booth Street to the east, Albert Island to the south and Energy Ottawa owned lands on Chaudière Island to the north, see site plan in **Drawings/Figures** for limits of Phase 1.

The subject site is currently comprised of thirteen parcels of land with two civic addresses, 3 & 4 Booth Street, herein referred to as the site.

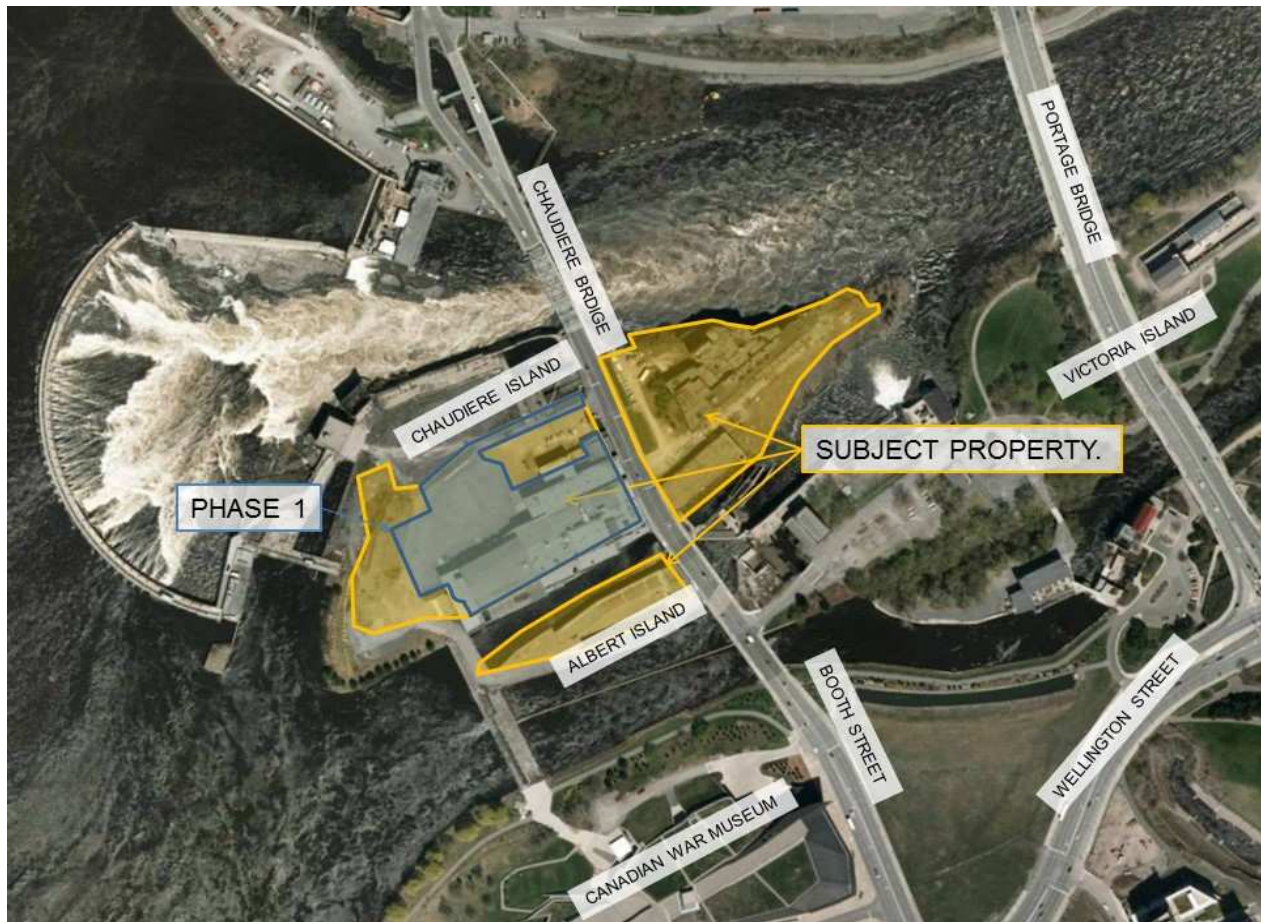

Figure 1: Site Location

The proposed development of Phase 1 involves the construction of a total of **5990m²** of retail, commercial and office space, approximately **71** residential units and all associated roadways, surface and underground parking.

The objective of this report is to support the application for Site Plan Control by providing sufficient detail to demonstrate that the development is supported by existing municipal servicing infrastructure and that the contemplated site design conforms to current City of Ottawa design standards, in addition to, state of the art design strategies to meet the client's "One Planet" strategy.

Servicing and grading presented in the detailed design of Phase 1 is consistent with the *Master Servicing Plan – Domtar Redevelopment Lands*, prepared by DSEL (May 2018), noting that servicing and grading will be updated to reflect any future changes to the Master Servicing Plan.

1.1 Existing Conditions

A detailed survey of Chaudière and Albert Islands was completed by Fairhall Moffat & Woodland Limited on December 11, 2014. As per the topographic survey, elevations vary from **46.20m** at the east edge of the Chaudière Island to **54.85m** to the west. Stantec Geomatics Ltd., completed topographical surveys of Booth Street, Fleet Street, Lloyd Street and Albert Street and compiled their results on April 20, 2018 topographical sketch.

The subject site currently consists of several vacant industrial facilities, historically part of a paper mill that was in operation until 2007.

The site is made up of existing building footprint and gravel covered vacant lands. A portion of the Chaudière Island lands west of Booth Street consist of grassed and landscaped area.

Sewer and watermain mapping, along with as-recorded drawings collected from the City of Ottawa, indicate that the following services exist across the property frontages within the adjacent municipal right-of-ways:

Booth Street:

- 203mm diameter ductile iron watermain (North of Middle Street);
- 305mm diameter PVC watermain (South of Middle Street);
- 250mm diameter sanitary sewer;
- 1200mm diameter storm sewer.

Middle Street:

- 203mm diameter ductile iron watermain;
- 250mm diameter sanitary sewer;
- 300mm diameter storm sewer;
- Sanitary pumping station northwest corner of the Portage Bridge and Middle Street.

Portage Bridge:

- 100mm diameter sanitary forcemain;
- Sanitary pumping station, northwest of the Portage Bridge and Wellington Street intersection;
- 450mm diameter storm sewer.

1.2 Required Permits / Approvals

Development of the site is subject to the City of Ottawa Planning and Development Approvals process. The City of Ottawa must approve detailed engineering design drawings and reports, prepared to support the proposed development plan.

The culverts draining the Buchanan Channel, the Electric Channel Span and Bronson Channel Span are all owned by Public Services and Procurement Canada (PSPC). Any works impacting the existing structures are to be coordinated with PSPC.

The proposed infrastructure is subject to the Ontario Water Resources Act and requires approval under Section 53. Two Environmental Compliance Approval applications are required. One for the new stormwater outlets to the Ottawa River to be submitted directly to the Ministry of Environment and Climate Change. The second application will be prepared under the City of Ottawa Transfer of Review project for the remaining infrastructure.

Furthermore, approval under Section 28 of the Conservation Authorities Act is required for the new outlets to the Ottawa River. The application will be prepared and submitted to the Rideau Valley Conservation Authority.

1.3 Pre-consultation

Pre-Consultation was conducted with the City of Ottawa and Rideau Valley Conservation Authority via email, along with a formal pre-consultation meeting held between the client and City staff on December 20, 2013. Correspondence and a servicing guidelines checklist are included in **Appendix A**.

2.0 GUIDELINES, PREVIOUS STUDIES, AND REPORTS

2.1 Existing Studies, Guidelines, and Reports

The following studies were utilized in the preparation of this report:

- **Ottawa Sewer Design Guidelines**,
City of Ottawa, *SDG002*, October 2012.
(*City Standards*)
 - Technical Bulletin ISDTB-2014-01
City of Ottawa, February 5, 2014.
(*ITSB-2014-01*)
 - Technical Bulletin PIEDTB-2016-01
City of Ottawa, September 6, 2016.
(*PIEDTB-2016-01*)
 - Technical Bulletin ISTB-2018-01
City of Ottawa, March 21, 2018.
(*ISTB-2018-01*)

- **Ottawa Design Guidelines – Water Distribution**
City of Ottawa, October 2012.
(*Water Supply Guidelines*)
 - Technical Bulletin ISD-2010-2
City of Ottawa, December 15, 2010.
(*ISD-2010-2*)
 - Technical Bulletin ISDTD-2014-2
City of Ottawa, May 27, 2014.
(*ISDTD-2014-2*)
 - Technical Bulletin ISDTB-2018-02
City of Ottawa, March 21, 2018.
(*ISDTB-2018-02*)

- **Stormwater Planning and Design Manual**,
Ministry of the Environment, March 2003.
(*SWMP Design Manual*)

- **Ontario Building Code Compendium**
Ministry of Municipal Affairs and Housing Building Development Branch,
January 1, 2010 Update.
(*OBC*)

- **Low Impact Development Stormwater Management Planning and Design Guide**
Toronto Region Conservation Authority (TRCA) & Credit Valley Conservation Authority (CVC), 2010,
(LID Manual)

- **Master Servicing Study – Domtar Redevelopment Lands**
DSEL, June, 2018.
(MSS – Domtar Redevelopment)

- **Drainage Management Manual**
Ministry of Transportation of Ontario (MTO), 1997.
(MTO Drainage Manual)

3.0 WATER SUPPLY SERVICING

3.1 Existing Water Supply Services

The subject property lies within the City of Ottawa 1W pressure zone. A 300mm diameter watermain exists within the Booth Street crossing the Bronson Channel to connect to a 203mm watermain within Middle Street. The subject site is fed by 203mm watermain within Middle Street and Booth Street (North of the Bronson Channel). Drawing **EX-1**, included with this report, illustrates the existing water distribution network.

Historically, the site would have been serviced via several 203mm diameter service laterals connecting to the 203mm diameter watermain within Booth Street. As discussed previously, the historical conditions of the site up until 2007 were entirely industrial.

Table 1 summarizes the **Water Supply Guidelines** employed in the preparation of the historical and proposed water demand estimate.

Table 1
Water Supply Design Criteria

Design Parameter	Value
Industrial – Heavy	55,000 L/gross ha/d
Restaurant Demand	125 L/seat/d
Residential Average Apartment	1.8 person/unit
Residential Daily Average	280 L/person/d
Residential Maximum Daily Demand*	4.9 x avg. day *
Residential Maximum Hourly*	7.4 x avg day *
Commercial-Floor space	2.5 L/m ² /d
Commercial-Industrial Maximum Daily Demand	1.5 x avg. day L/gross ha/d
Commercial-Industrial Maximum Hour Demand	1.8 x max. day L/gross ha/d
Minimum Watermain Size	150mm diameter
Minimum Depth of Cover	2.4m from top of watermain to finished grade
During normal operating conditions desired operating pressure is within	350kPa and 480kPa
During normal operating conditions pressure must not drop below	275kPa
During normal operating conditions pressure shall not exceed	552kPa
During fire flow operating pressure must not drop below	140kPa
* Residential Max. Daily and Max. Hourly peaking factors per MOE Guidelines for Drinking-Water Systems Table 3-3, see calculations in Appendix B for peaking factors for Phase 1	
*** Table updated to reflect ISD-2018-2	

Table 2 Summarizes the historical water demand based on the current City of Ottawa **Water Supply Guidelines**.

Table 2
Water Demand - Historical Site Conditions

Design Parameter	Historical Water Demand ¹ (L/min)
Average Daily Demand	216.6
Max Day	324.8
Peak Hour	584.7
1) Water demand calculations per Water Supply Guidelines . Refer to Appendix B for detailed calculations.	

3.2 Water Supply Servicing Design

The proposed water servicing will consist of new 200mm and 300mm watermains from the subject site, traveling south down Booth Street and across the Electric and Bronson Channels. A pipe bridge is proposed on the west side of the channel to house the watermains. The 300mm watermain is proposed to connect to the existing 300mm watermain within Booth Street and the 200mm watermain is proposed to connect to the existing 400mm watermain at the intersection of Booth Street and Wellington Street. The proposed 200mm watermain is required to connect to the east side of the butterfly valve at the east side of the intersection of Wellington Street and Booth Street. Internal 200mm and 300mm watermains are proposed to service Phase 1.

Each building will be serviced independently via connections to the private watermain network. Fire hydrants will be provided internally to provide adequate fire protection coverage, as per the **Water Supply Guidelines**. Fire flow for the proposed and re-purposed building was estimated per **ISTB-2018-02**. Block 205-A resulted in the highest fire flow of **10,000 L/min**, see **Appendix B** for detailed calculations. The pipes have been sufficient sized to provide fire flow for all buildings in the ultimate condition.

Table 3 summarize the anticipated water demand and boundary conditions for the proposed development, calculated using the **Water Supply Guidelines**.

Table 3
Water Demand – Proposed Site Conditions

Design Parameter	Anticipated Demand ¹ Phase 1 (L/min)	Boundary Condition ² (m H ₂ O / kPa) Connection @ Booth Street		Boundary Condition ² (m H ₂ O / kPa) Connection @ Wellington Street	
Average Daily Demand	32.8	61.7	605.3	58.6	574.9
Max Day + Fire Flow	128.7 + 10,000 = 10,128.7	50.3	493.4	52.5	515.0
Peak Hour	198.5	54.7	536.6	51.6	506.2
1) Water demand calculation per Water Supply Guidelines . See Appendix B for detailed calculations. 2) Boundary conditions supplied by the City of Ottawa for demands as indicated in correspondence. Assumed ground elevation @ Booth Street 53.4m , @ Wellington Street 56.5m , See Appendix B .					

The boundary conditions summarized in **Table 3** are based water demands for Phase 1 development. After further information was received on commercial, retail, office and community space, the resulting water demands decreased.

3.3 Water Modeling

EPANet was utilized to determine the availability of pressures throughout the system during average day demand, max day plus fire flow, and peak hour demands. Additionally, the model was used to assess maximum pressure for the future conditions. This static model determines pressures based on the available head provided by the City of Ottawa boundary conditions. The model utilizes the Hazen-Williams equation to determine pressure drop, while the pipe properties have been selected in accordance with **Water Supply Guidelines**. The model was prepared to assess the available pressure at the finished first floor of each building.

Two hydrants are proposed to service the site for Phase 1 of the development; labeled hydrant 7 and hydrant 5 in the EPANet figures provided in **Appendix B**. Fire flow scenario through Hydrant 5 causes the lowest pressure through the system. However, both of these nodes are capable of sustaining **10,000 L/min**, as per the **ISTB-2018-02** estimated fire demand for this phase, while also maintaining the standards outlined in **Table 1**.

Table 4 summarizes the pressures in each scenario, including the fire flow scenario yielding the lowest pressure. **Appendix B** contains output reports and model schematics for each scenario.

Table 4
Model Simulation Output Summary – Phase 1

Location	Average Day (kPa)	Max Day + Fire Flow (kPa)	Peak Hour (kPa)
Block 208	601.0	452.3	532.3
Block 205A	596.1	435.6	527.3
EX1	624.9	504.2	556.2
FH 7 (Node 3)	598.4	463.4	529.7
FH 5 (Node 30)	599.0	421.6	530.2
Note: FH5 & FH7 modelled assuming a fire flow of 10,000 L/min demand run through FH5 for max. day plus fire flow scenario.			

As demonstrated in **Table 4**, the anticipated pressures during the average day simulations and nodes at the north end of the system during peak hour simulation are higher than allowable pressures in **Table 1**. Pressure reducing valves are recommended. The recommended pressures from the **Water Supply Guidelines** are respected during max day + fire flow scenarios.

The model predicted that water will flow in all areas of the system and no ‘dead’ zones were found.

It should be noted that the pressures in **Table 4** represent the available pressure at the building meter. The mechanical designer must ensure that the internal distribution system is designed in accordance with the OBC.

3.4 Water Supply Conclusion

The site will be serviced by a 300mm and 200mm watermain within Booth Street; one to connect to the existing 300mm watermain within Booth Street a second connection to the existing 400mm watermain within Wellington Street.

An EPANet model was prepared based on boundary conditions received from the City of Ottawa. Pressures in average day and peak hour scenario exceed the recommended pressures, as per the **Water Supply Guidelines**, therefore pressure reducing valves are recommended. The proposed system is sufficiently sized to provide fire flow at minimum pressures.

The proposed water supply design conforms to all relevant City Guidelines and Policies.

4.0 WASTEWATER SERVICING

4.1 Existing Wastewater Services

The subject site, based on City of Ottawa's infrastructure maps & utility plans, is connected to the 250mm sanitary sewer within Middle Street. To accomplish this connection, a series of pumps stations direct flow to a single private pump station within the subject lands, east of Booth Street (Building 535). This existing private pump station discharges via a forcemain to the Middle Street sanitary sewer. A figure, prepared by Greenough Environmental Consulting Inc. for Domtar Inc., showing the location of on-site pump stations and forcemains can be found in ***Drawings/Figures***. The Middle Street sanitary sewer discharges via gravity flow to an existing pump station northwest of the intersection of Middle Street and The Portage Bridge. A 100mm forcemain directs sanitary flow to a second pump station to the south, across the Bronson Channel. The south pump station discharges via a 100mm forcemain to the 1830mm diameter interceptor sewer (IS) north of Sparks Street. Both pump stations are owned and operated by the NCC and service commercial and recreational development on Victoria Island.

Refer to drawings ***EX-1*** and ***EX-2***, included with this report, for existing wastewater services.

A field investigation of the existing main pump station on Chaudière Island was completed by DSEL on June 30, 2015. The field investigation was to determine the existing condition of the pump station including: wet well size; start and stop elevations; pump type and model; and existing pump discharge. A flow rate of **6.7 L/s** was observed during operation of the pump through the existing flow meter connected to the forcemain. The pump curve based on the existing pumps was obtained from the manufacturer. The pump curve suggests that the observed flow rate would result in the pump operating in an overloaded condition. See existing pump curve information in a technical memo by Hatch, provided in ***Appendix C***.

Table 5 summarizes the ***City Standards*** employed in the estimate of available capacity within the municipal wastewater sewer systems, as well as, in the calculation of wastewater flow rates for the historical and proposed development.

Table 5
Wastewater Design Criteria

Design Parameter	Value
Industrial-Heavy	55,000 L/gross ha/d
Restaurant Demand	125 L/seat/d
Industrial Peaking Factor*	4.75
Residential 1 Bedroom Apartment Demand	1.4 person/unit
Residential 2 Bedroom Apartment Demand	2.1 person/unit
Residential Average Apartment Demand	1.8 person/unit
Residential Daily Average	280 L/person/d
Commercial Floor Space	5 L/m ² /d
Peaking Factor	Harmon's Peaking Factor. Max 3.8, Min 2.0 Correction Factor = 0.8
Infiltration and Inflow Allowance	0.33L/s/ha
Sanitary sewers are to be sized employing the Manning's Equation	$Q = \frac{1}{n} AR^{2/3} S^{1/2}$
Minimum Sanitary Sewer Lateral	135mm diameter
Minimum Manning's 'n'	0.013
Minimum Depth of Cover	2.5m from crown of sewer to grade
Minimum Full Flowing Velocity	0.6m/s
Maximum Full Flowing Velocity	3.0m/s
* Industrial Peaking Factor determined as per MOE Guidelines for the Design of Sanitary Sewers, Typical Industrial Sewage Flow Peaking Factors Graph. Extracted from Sections 4 and 6 of the City of Ottawa Sewer Design Guidelines, October 2012.	

4.2 Wastewater Design

The ultimate design proposes a new sanitary pump station on the east edge of Chaudiere Island. The proposed internal sanitary system, consisting of 250mm diameter sanitary sewers, will collect the sanitary flow from the site and will flow to the proposed pump station. The proposed twin 200mm diameter forcemains will convey flow from the pump station south down Booth Street. A pipe bridge is proposed to allow the twin forcemains to cross the Electric and Bronson Channel spans. The forcemains are proposed to travel further south along Booth, east on Fleet Street and south down Lloyd Street. The forcemains are proposed to cross the existing aquaduct and discharge to a proposed sanitary manholes on the north side of the LRT Tunnel. Gravity sewers convey flow across the LRT tunnel prior to discharging to the existing 450mm sanitary sewer within Albert Street and eventually the Interceptor Sewer, in accordance with the **MSS – Domtar Redevelopment**.

The proposed forcemains from the pump station to the new sanitary structure north of the LTR will remain in private ownership. A license to occupy will be required within the municipal ROW and future park. The gravity portion of sanitary sewer over the LRT and manholes north and south of the LRT will be conveyed to the City.

It is proposed in the interim to construct the off-site forcemain as described above and retrofit the existing private pump station with Building 535. A design brief for the retrofitted pump station is submitted under separate cover by Hatch.

Individual buildings within the proposed development will be serviced internally via gravity draining sanitary sewer network; detailed layout and sizing is shown by drawing **SSP-1** included with this report.

Table 6 below summarizes the anticipated wastewater discharge from the proposed development based on criteria found in **Table 5**.

Table 6
Summary of Anticipated Wastewater Discharge

Design Parameter	Phase 1 Flow (L/s)
Average Dry Weather Flow Rate	0.7
Peak Dry Weather Flow Rate	1.8
Peak Wet Weather Flow Rate	2.2

The estimated proposed sanitary flow for Phase 1 based on the architectural site plan is **2.2 L/s**.

City of Ottawa **Technical Bulletin ISTB-2018-01**, was employed to generate an estimate of the proposed wastewater flow conditions.

In the event of service interruption, mobile pumper trucks will be employed until the service is restored.

4.3 Wastewater Servicing Conclusion

Ultimate servicing is provided by a centralized pump station on the east edge of Chaudiere Island. Twin forcemains are proposed to convey flow south, crossing the LRT tunnel and discharging to a gravity sewer within Albert Street, eventually discharging to the Interceptor Sewer.

An interim pump station is proposed within Building 535. The pump station is proposed to discharge to the ultimate forcemains proposed within Booth Street.

The proposed wastewater design conforms to all relevant **City Standards**.

5.0 STORMWATER MANAGEMENT

5.1 Existing Stormwater Services

Stormwater runoff from the existing subject property is directed uncontrolled to the Ottawa River. The major and minor flow is directed to the Ottawa River overland with a small portion of flow directed by catch basins along Booth Street. The site currently consists of varying sloped topography (0.5% to >5%) and mostly impervious building footprint or associated parking area.

The existing site contains no stormwater management quality controls or controls for flow attenuation.

Runoff from the site is directed to the Ottawa River directly downstream of the Chaudière Falls which has a drop and breadth of 15 and 60m, respectively. The dam is used by Hydro Ottawa and Hydro-Quebec to produce electricity. The dam is also monitored and controlled by the Ottawa River Regulation and Planning Board for flood control.

5.2 Post-development Stormwater Management Targets

Stormwater management requirements for the proposed development are based on relevant **City Standards** and pre-consultation with City of Ottawa and Rideau Valley Conservation Authority staff. It has been established that the following criteria apply:

- Increase to flood risk and flood levels in the Ottawa River will not be impacted by the proposed development and therefore stormwater quantity controls are not required;
- Based on the consultation with the City & RVCA, stormwater quality controls will be required to achieve an “enhanced” level of quality control as per the **SWMP Design Manual**, 80% reduction in Total Suspended Solids (TSS) prior to release to the Ottawa River.

5.3 Stormwater Management System

The stormwater management system will consist of a private storm sewer system, outlasting at the north edge of Chaudière Island, east of Booth Street.

The private stormwater sewer system has been sized to convey an uncontrolled 5-year storm runoff rate in accordance with the **City Standards**. Detailed layout and sizing is illustrated by **SSP-1** which is included with this report.

The Rational Method was utilized to calculate the runoff from the storm sewer catchment areas; Rational Method “C” values for the catchment areas were derived using “*Table 5.7 Runoff Coefficients for Various Soil Conditions*” from the **City Standards**.

To meet the specified stormwater quality criteria, an end of pipe oil/grit separator (OGS) unit will be designed to provide a TSS reduction of at least 80% achieving an “enhanced” level of quality control, as per the **SWMP Design Manual**. Rooftop runoff is considered clean, therefore, buildings adjacent to the shoreline will have roof leaders discharge directly the Ottawa River, as per pre-consultation with the RVCA. It is proposed to provide a Stormceptor **STC4000** (or approved equivalent) prior to discharge to the Ottawa River. A hydrodynamic separator is also contemplated within the parking garage of the building to treat any surface water entering the internal mechanical system from the access road or courtyard area to 80% TSS Removal. Refer to the internal mechanical plans for details of the internal quality control.

5.4 Minor and Major System Flow

Stormwater conveyance is achieved through a minor system comprised of catch basins and storm sewers and a major system comprised of overland flow within the 6.0m asphalt access road. Inlet control devices are not proposed for the catch basins, CB capture has been analyzed to ensure that a minimum of the 2-year storm event is captured by the minor system. During storm events larger than the 2-year storm event, the access road is used to convey flow to Booth Street and north to the Ottawa River.

Two minor system outlets are proposed in Phase 1. The first outlet is proposed to capture the future flow from the west edge of the Island and the majority of flow from the temporary parking area, refer to area **FUT** and **104B** on drawing **SWM-1** included with this report. Minor system flow is conveyed by storm sewers to the proposed HW100, outleting to the Ottawa River, east of Booth Street. A second outlet is proposed to convey flow from the internal courtyard, noted drainage area **104A** on drawing **SWM-1**, through the building mechanical system to an outlet east of Booth and south of Building 535.

Major system flow from both drainage areas is directed overland via access lanes or the courtyard to Booth Street where it is conveyed north overland and eventually discharges to the Ottawa River.

A dynamic stormwater management model was prepared to analyze the flow to the minor and major system for Phase 1. The model contemplates the future flow from construction of Phase 2 and all future phases west of Booth Street on Chaudière Island in accordance with the **MSS – Domtar Redevelopment**. Drainage areas in the dynamic model are consistent with those shown in drawing **SWM-1**.

5.4.1 Model Summary

The hydrology and hydraulics of the proposed stormwater management system were analyzed in EPASWMM using the Dynamic Wave Routing Model.

The following assumptions were made in the preparation for the EPASWMM model:

Hydrology:

- Initial abstraction parameters per City of Ottawa standards;
- Horton’s infiltration for soil loss, per City guidelines;
- Calculated % impervious area;
- Sub-catchment width measured as perpendicular area to catch basins for longest distance of travel;
- A 4 Hour Chicago Distribution resulted in the high peak flow and was used in the analysis.

Hydraulics:

- Storage Nodes represent both surface and subsurface components. Each node is assigned an invert elevation that corresponds with the tributary catch basin;
- “Regular” Node represent either connections to the sewer main or strategic maintenance structure locations. Not all structures have been included in model;
- All conduits have been assigned a Mannings $n = 0.013$;
- CB capture along a continuous slope analyzed with an “bottom draw” orifice represented by a square orifice opening of a CB (0.125m^2) multiplied by the number of CB within the catchment. Assumes top of lid for CB on a continuous sag is 3cm below grade and a discharge coefficient of 0.61;
- CB capture within a sag calculated using Table 4.19 from the ***MTO Drainage Manual*** for CB Capture and the Orifice Equation (per the ***City Standards***) to calculate CB Lead Capture. The lower of the CB Capture or CB Lead Capture was used to determine the capture at incremental heads, refer to ***Appendix D*** for the stage-discharge curve for single and twin CB and a 250mm lead used in the analysis;
- Trench Drain capture equal to 5.9 L/s per manufacturer specification, refer to ***Appendix D*** for specification.

5.4.2 Model Results

As previously discussed, the minor system has been designed to capture the 2-year storm event. Larger storm events are proposed to use the access road as a major flow route. **Table 7** below, summarizes the minor system flow, major system flow and major system depth of flow during various storm events.

Table 7
Summary of Minor and Major System Flow, 4 Hour Chicago Storm Distribution

Storm Event	Minor / Major System Flow from Area Fut & 104B (1.059 Ha)			Minor / Major System Flow from Area 104A (0.234 Ha)		
	Minor Flow to HW100 (L/s)	Major Flow to Booth (L/s)	On-Site Max Flow Depth (m)	Minor Flow to Outlet South of 535 (L/s)	Major Flow to Booth (L/s)	On-Site Max Flow Depth (m)
2-Year	183.5	0.28	0.0	15.8	0	0
5-Year	246.6	18.2	0.02	22.3	0	0
100-Year	344.5	121.3	0.10	60.0	0	0

As shown in the table above, the minor system is capable of capturing the 2-year storm event. A 0.28 L/s flow does result in the 2-year event within Perley Street, the flow is minor and does not result in measurable overland flow depth. The major system flow is limited to a flow depth of 0.02m and 0.10m in the 5-year and 100-year storm event respectively within Perley Street. The minor system within the courtyard is capable of capturing up to the 100-year storm event. Refer to **Appendix D** for model results for each storm event and model schematic. Refer to **Figure 2** below, for the node diagram representing the model.

Figure 2: Minor and Major EPASWMM Node Diagram

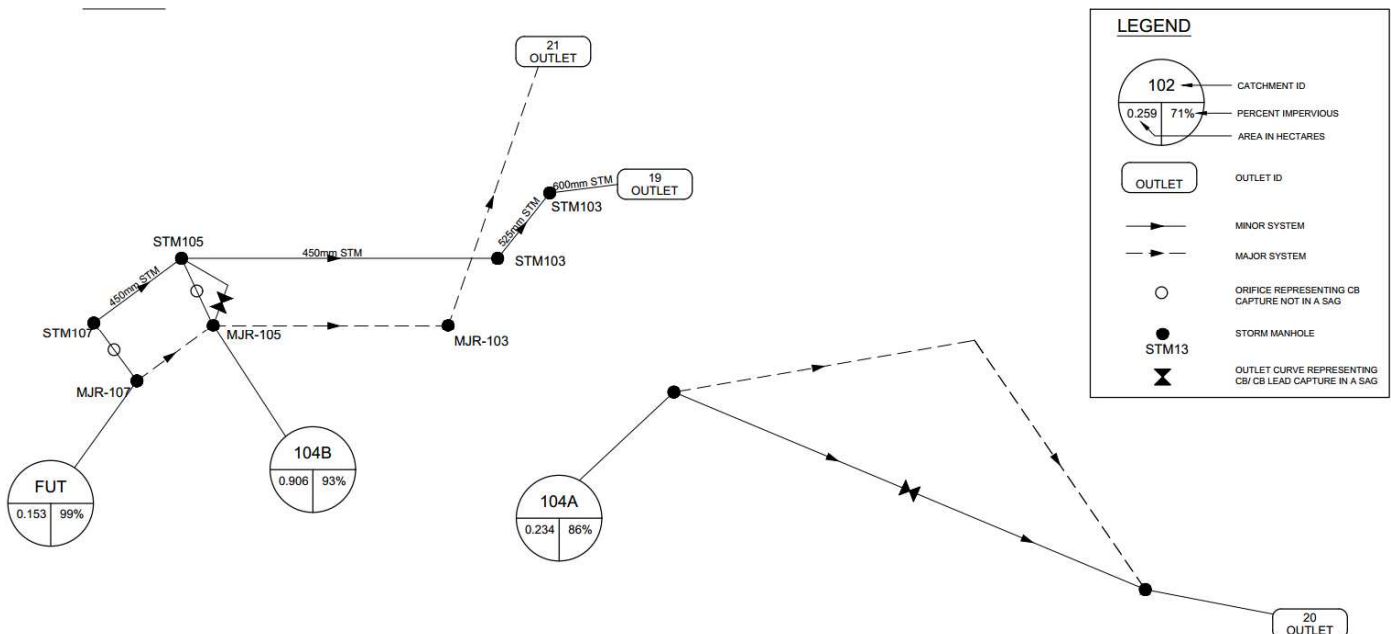

5.5 Stormwater Servicing Conclusions

Stormwater runoff will be captured by a private storm sewer system conveyed to an outlet to the Ottawa River, located east of Booth Street.

Private storm sewer is designed to convey the uncontrolled 5-year runoff rate, in accordance with the **City Standards**.

To achieve the runoff quality criteria identified through consultation, an end of pipe oil/grit separator will provide an “enhanced” level of treatment, as per the **SWMP Design Manual**.

A dynamic stormwater management model was completed to analyze the minor system and major system capture on-site. Based on the model the 2-year storm event is fully captured within the minor system and overland flow is limited to 0.10m in the 100-year storm event.

The design of the proposed storm sewer system conforms to all relevant **City Standards**.

6.0 EROSION AND SEDIMENT CONTROL

Soil erosion occurs naturally and is a function of soil type, climate and topography. The extent of erosion losses is exaggerated during construction where vegetation has been removed and the top layer of soil becomes agitated.

Prior to topsoil stripping, earthworks or underground construction, erosion and sediment controls will be implemented and will be maintained throughout construction.

Silt fence will be installed around the perimeter of the site and will be cleaned and maintained throughout construction. Silt fence will remain in place until the working areas have been stabilized and re-vegetated.

Catchbasins will have a *Siltsack* or approved equivalent installed under the grate during construction to protect silt from entering the storm sewer system. Inlet catchbasins will have *Inletsoxx* or approved equivalent installed during construction to protect silt from entering the storm sewer system

A mud mat will be installed at the construction access in order to prevent mud tracking onto adjacent roads.

- Erosion and sediment controls must be in place during construction, See **EC-1**, included with this report, for detailed erosion and sediment control measures. The following recommendations to the contractor will be included in contract documents:
 - Limit extent of exposed soils at any given time;
 - Re-vegetate exposed areas as soon as possible;
 - Minimize the area to be cleared and grubbed;
 - Protect exposed slopes with plastic or synthetic mulches;
 - Install silt fence to prevent sediment from entering existing ditches;
 - No refueling or cleaning of equipment near existing watercourses;
 - Provide sediment traps during dewatering;
 - Install appropriate catch basins inlet protection;
 - Plan construction at proper time to avoid flooding;
 - Establish material stockpiles away from watercourses, so that barriers and filters may be installed.
- The contractor will, at every rainfall, complete inspections and guarantee proper performance. The inspection is to include:
 - Verification that water is not flowing under silt barriers;

- Clean and replace Siltsack, as needed, at catch basins.

In addition to the above-mentioned erosion and sediment controls, the storm sewer system and OGS shall be installed prior to extensive site works. All runoff will be directed to the OGS prior to discharge to the Ottawa River. Daily inspection of the OGS and pumping, if required, shall be implemented during the entire duration of the site works.

7.0 UTILITIES

Utility services will need to be coordinated with utility companies prior to development.

Existing gas mains are located within the Booth Street right-of-way

Existing Bell cable are located within the Booth Street right-of-way and the Portage Bridge.

AUGUST 2018 – REV 4

8.0 CONCLUSION AND RECOMMENDATIONS

David Schaeffer Engineering Ltd. (DSEL) has been retained to prepare a Functional Servicing and Stormwater Management Report to support the proposed development of Domtar Lands Redevelopment in support of Windmill Development Group's application for Site Plan Control (SPC). The following are the conclusions and recommendations generated by this report:

- An internal water distribution model was completed that verified pressures during average day and peak hour scenarios, pressure reducing control are recommended based on the resulting pressures;
- Fire hydrants are proposed to provide adequate fire protection at each building in Phase 1;
- Sanitary servicing is to be provided by a temporary pump station within Building 525, conveying flow to the forcemains
- A minimum TSS removal of 80% will be required for post-development stormwater runoff from the site, provided by an end of pipe oil/grit separator;
- Utility services will need to be coordinated with utility companies prior to development;

Based on the preceding report, adequate servicing capacity exists to support the proposed development.

Prepared by,
David Schaeffer Engineering Ltd.

Reviewed by,
David Schaeffer Engineering Ltd.



Per: Steven L. Merrick, P.Eng.

Per: Adam D. Fobert, P.Eng

APPENDIX A

Pre-Consultation

DEVELOPMENT SERVICING STUDY CHECKLIST

14-717

17/04/2014

4.1 General Content		
<input type="checkbox"/>	Executive Summary (for larger reports only).	N/A
<input checked="" type="checkbox"/>	Date and revision number of the report.	Report Cover Sheet
<input checked="" type="checkbox"/>	Location map and plan showing municipal address, boundary, and layout of proposed development.	Drawings/Figures
<input checked="" type="checkbox"/>	Plan showing the site and location of all existing services.	Figure 1
<input checked="" type="checkbox"/>	Development statistics, land use, density, adherence to zoning and official plan, and reference to applicable subwatershed and watershed plans that provide context to applicable subwatershed and watershed plans that provide context to which individual developments must adhere.	Section 1.0
<input checked="" type="checkbox"/>	Summary of Pre-consultation Meetings with City and other approval agencies.	Section 1.3
<input checked="" type="checkbox"/>	Reference and confirm conformance to higher level studies and reports (Master Servicing Studies, Environmental Assessments, Community Design Plans), or in the case where it is not in conformance, the proponent must provide justification and develop a defensible design criteria.	Section 2.1
<input checked="" type="checkbox"/>	Statement of objectives and servicing criteria.	Section 1.0
<input checked="" type="checkbox"/>	Identification of existing and proposed infrastructure available in the immediate area.	Sections 3.1, 4.1, 5.1
<input checked="" type="checkbox"/>	Identification of Environmentally Significant Areas, watercourses and Municipal Drains potentially impacted by the proposed development (Reference can be made to the Natural Heritage Studies, if available).	Section 5.0
<input checked="" type="checkbox"/>	Concept level master grading plan to confirm existing and proposed grades in the development. This is required to confirm the feasibility of proposed stormwater management and drainage, soil removal and fill constraints, and potential impacts to neighbouring properties. This is also required to confirm that the proposed grading will not impede existing major system flow paths.	GP-1
<input type="checkbox"/>	Identification of potential impacts of proposed piped services on private services (such as wells and septic fields on adjacent lands) and mitigation required to address potential impacts.	N/A
<input type="checkbox"/>	Proposed phasing of the development, if applicable.	N/A
<input checked="" type="checkbox"/>	Reference to geotechnical studies and recommendations concerning servicing.	Section 1.4
<input checked="" type="checkbox"/>	All preliminary and formal site plan submissions should have the following information: -Metric scale -North arrow (including construction North) -Key plan -Name and contact information of applicant and property owner -Property limits including bearings and dimensions -Existing and proposed structures and parking areas -Easements, road widening and rights-of-way -Adjacent street names	SSP-1
4.2 Development Servicing Report: Water		
<input type="checkbox"/>	Confirm consistency with Master Servicing Study, if available	N/A
<input checked="" type="checkbox"/>	Availability of public infrastructure to service proposed development	Section 3.1
<input checked="" type="checkbox"/>	Identification of system constraints	Section 3.1
<input checked="" type="checkbox"/>	Identify boundary conditions	Section 3.1, 3.2
<input checked="" type="checkbox"/>	Confirmation of adequate domestic supply and pressure	Section 3.3

<input checked="" type="checkbox"/>	Confirmation of adequate fire flow protection and confirmation that fire flow is calculated as per the Fire Underwriter's Survey. Output should show available fire flow at locations throughout the development.	Section 3.2
<input checked="" type="checkbox"/>	Provide a check of high pressures. If pressure is found to be high, an assessment is required to confirm the application of pressure reducing valves.	Section 3.2
<input type="checkbox"/>	Definition of phasing constraints. Hydraulic modeling is required to confirm servicing for all defined phases of the project including the ultimate design	N/A
<input type="checkbox"/>	Address reliability requirements such as appropriate location of shut-off valves	N/A
<input type="checkbox"/>	Check on the necessity of a pressure zone boundary modification	N/A
<input checked="" type="checkbox"/>	Reference to water supply analysis to show that major infrastructure is capable of delivering sufficient water for the proposed land use. This includes data that shows that the expected demands under average day, peak hour and fire flow conditions provide water within the required pressure range	Section 3.2, 3.3
<input checked="" type="checkbox"/>	Description of the proposed water distribution network, including locations of proposed connections to the existing system, provisions for necessary looping, and appurtenances (valves, pressure reducing valves, valve chambers, and fire hydrants) including special metering provisions.	Section 3.2
<input type="checkbox"/>	Description of off-site required feeder mains, booster pumping stations, and other water infrastructure that will be ultimately required to service proposed development, including financing, interim facilities, and timing of implementation.	N/A
<input checked="" type="checkbox"/>	Confirmation that water demands are calculated based on the City of Ottawa Design Guidelines.	Section 3.2
<input type="checkbox"/>	Provision of a model schematic showing the boundary conditions locations, streets, parcels, and building locations for reference.	N/A

4.3 Development Servicing Report: Wastewater

<input checked="" type="checkbox"/>	Summary of proposed design criteria (Note: Wet-weather flow criteria should not deviate from the City of Ottawa Sewer Design Guidelines. Monitored flow data from relatively new infrastructure cannot be used to justify capacity requirements for proposed infrastructure).	Section 4.2
<input type="checkbox"/>	Confirm consistency with Master Servicing Study and/or justifications for deviations.	N/A
<input type="checkbox"/>	Consideration of local conditions that may contribute to extraneous flows that are higher than the recommended flows in the guidelines. This includes groundwater and soil conditions, and age and condition of sewers.	N/A
<input checked="" type="checkbox"/>	Description of existing sanitary sewer available for discharge of wastewater from proposed development.	Section 4.1
<input checked="" type="checkbox"/>	Verify available capacity in downstream sanitary sewer and/or identification of upgrades necessary to service the proposed development. (Reference can be made to previously completed Master Servicing Study if applicable)	Section 4.2
<input checked="" type="checkbox"/>	Calculations related to dry-weather and wet-weather flow rates from the development in standard MOE sanitary sewer design table (Appendix 'C') format.	Section 4.2, Appendix C
<input checked="" type="checkbox"/>	Description of proposed sewer network including sewers, pumping stations, and forcemains.	Section 4.2
<input type="checkbox"/>	Discussion of previously identified environmental constraints and impact on servicing (environmental constraints are related to limitations imposed on the development in order to preserve the physical condition of watercourses, vegetation, soil cover, as well as protecting against water quantity and quality).	N/A

<input checked="" type="checkbox"/>	Pumping stations: impacts of proposed development on existing pumping stations or requirements for new pumping station to service development.	Section 4.0
<input type="checkbox"/>	Forcemain capacity in terms of operational redundancy, surge pressure and maximum flow velocity.	N/A
<input type="checkbox"/>	Identification and implementation of the emergency overflow from sanitary pumping stations in relation to the hydraulic grade line to protect against basement flooding.	N/A
<input type="checkbox"/>	Special considerations such as contamination, corrosive environment etc.	N/A

4.4 Development Servicing Report: Stormwater Checklist

<input checked="" type="checkbox"/>	Description of drainage outlets and downstream constraints including legality of outlets (i.e. municipal drain, right-of-way, watercourse, or private property)	Section 5.1
<input checked="" type="checkbox"/>	Analysis of available capacity in existing public infrastructure.	Section 5.1, Appendix D
<input checked="" type="checkbox"/>	A drawing showing the subject lands, its surroundings, the receiving watercourse, existing drainage patterns, and proposed drainage pattern.	EX-1
<input checked="" type="checkbox"/>	Water quantity control objective (e.g. controlling post-development peak flows to pre-development level for storm events ranging from the 2 or 5 year event (dependent on the receiving sewer design) to 100 year return period); if other objectives are being applied, a rationale must be included with reference to hydrologic analyses of the potentially affected subwatersheds, taking into account long-term cumulative effects.	Section 5.2
<input checked="" type="checkbox"/>	Water Quality control objective (basic, normal or enhanced level of protection based on the sensitivities of the receiving watercourse) and storage requirements.	Section 5.2
<input checked="" type="checkbox"/>	Description of the stormwater management concept with facility locations and descriptions with references and supporting information	Section 5.3
<input type="checkbox"/>	Set-back from private sewage disposal systems.	N/A
<input checked="" type="checkbox"/>	Watercourse and hazard lands setbacks.	GP-1
<input checked="" type="checkbox"/>	Record of pre-consultation with the Ontario Ministry of Environment and the Conservation Authority that has jurisdiction on the affected watershed.	Appendix A
<input checked="" type="checkbox"/>	Confirm consistency with sub-watershed and Master Servicing Study, if applicable study exists.	Section 5.2
<input checked="" type="checkbox"/>	Storage requirements (complete with calculations) and conveyance capacity for minor events (1:5 year return period) and major events (1:100 year return period).	Section 5.3
<input checked="" type="checkbox"/>	Identification of watercourses within the proposed development and how watercourses will be protected, or, if necessary, altered by the proposed development with applicable approvals.	Section 6.0
<input checked="" type="checkbox"/>	Calculate pre and post development peak flow rates including a description of existing site conditions and proposed impervious areas and drainage catchments in comparison to existing conditions.	Section 5.1, 5.3
<input type="checkbox"/>	Any proposed diversion of drainage catchment areas from one outlet to another.	N/A
<input checked="" type="checkbox"/>	Proposed minor and major systems including locations and sizes of stormwater trunk sewers, and stormwater management facilities.	Appendix D
<input type="checkbox"/>	If quantity control is not proposed, demonstration that downstream system has adequate capacity for the post-development flows up to and including the 100-year return period storm event.	N/A
<input type="checkbox"/>	Identification of potential impacts to receiving watercourses	N/A
<input type="checkbox"/>	Identification of municipal drains and related approval requirements.	N/A

<input checked="" type="checkbox"/>	Descriptions of how the conveyance and storage capacity will be achieved for the development.	Section 5.3
<input checked="" type="checkbox"/>	100 year flood levels and major flow routing to protect proposed development from flooding for establishing minimum building elevations (MBE) and overall grading.	SWM-1
<input type="checkbox"/>	Inclusion of hydraulic analysis including hydraulic grade line elevations.	N/A
<input checked="" type="checkbox"/>	Description of approach to erosion and sediment control during construction for the protection of receiving watercourse or drainage corridors.	Section 7.0
<input type="checkbox"/>	Identification of floodplains – proponent to obtain relevant floodplain information from the appropriate Conservation Authority. The proponent may be required to delineate floodplain elevations to the satisfaction of the Conservation Authority if such information is not available or if information does not match current conditions.	N/A
<input type="checkbox"/>	Identification of fill constraints related to floodplain and geotechnical investigation.	N/A

4.5 Approval and Permit Requirements: Checklist

<input checked="" type="checkbox"/>	Conservation Authority as the designated approval agency for modification of floodplain, potential impact on fish habitat, proposed works in or adjacent to a watercourse, cut/fill permits and Approval under Lakes and Rivers Improvement Act. The Conservation Authority is not the approval authority for the Lakes and Rivers Improvement ct. Where there are Conservation Authority regulations in place, approval under the Lakes and Rivers Improvement Act is not required, except in cases of dams as defined in the Act.	Section 1.2
<input type="checkbox"/>	Application for Certificate of Approval (CofA) under the Ontario Water Resources Act.	N/A
<input type="checkbox"/>	Changes to Municipal Drains.	N/A
<input type="checkbox"/>	Other permits (National Capital Commission, Parks Canada, Public Works and Government Services Canada, Ministry of Transportation etc.)	N/A

4.6 Conclusion Checklist

<input checked="" type="checkbox"/>	Clearly stated conclusions and recommendations	Section 9.0
<input checked="" type="checkbox"/>	Comments received from review agencies including the City of Ottawa and information on how the comments were addressed. Final sign-off from the responsible reviewing agency.	Attached Response Letter
<input type="checkbox"/>	All draft and final reports shall be signed and stamped by a professional Engineer registered in Ontario	

Steve Merrick

Subject: RE: Watermain testing Booth Street

From: Dover, Steve [<mailto:Steve.Dover@ottawa.ca>]

Sent: June 16, 2015 1:19 PM

To: 'Adam Fobert'

Cc: Buchanan, Richard; Smadella, Karin

Subject: RE: Watermain testing Booth Street

Hi Adam,

Should the City require that a leakage test is undertaken on Booth Street under the water channel for 305 mm PVC watermain installed in 1995, the City's Water Distribution staff would undertake the test since the test would require operation of valves as well as notification of water service disruption.

Based on the age and watermain material installed I see no reason to undertake a leakage test of this section of watermain.

Regards,

Steve Dover
Project Manager
Environmental Engineering, City of Ottawa
951 Clyde Avenue, Ottawa, ON K1Z 5A6
Tel: (613) 580-2424 Ext.13613
Cell: (613) 266-3809
Fax: (613) 728-4183
e-mail: steve.dover@ottawa.ca

From: Adam Fobert [<mailto:afobert@dsel.ca>]

Sent: Tuesday, June 16, 2015 11:12 AM

To: Dover, Steve

Cc: Buchanan, Richard

Subject: Watermain testing

Hello Steve,

It was nice to finally meet you face to face on Friday regarding the Windmill project.

You had mentioned a couple of names of companies that could perform a leakage test of that existing 300mm PVC main crossing the river. Could you pass those names on?

Also, I'm assuming that we'd have to shut the main down to do this test. Is there a protocol for informing users of the shut down? Are there specifications that I need to pass onto the contractor performing the leakage test? And lastly, I'm assuming that we'll need a City watermain inspector present since they'll be touching a piece of municipal infrastructure. Correct?

Thanks for your help.

******* PLEASE NOTE THE CHANGES TO THE PHONE NUMBER AND UNIT NUMBER *******

Adam Fobert, P.Eng.
Manager of Site Plan Design

DSEL

david schaeffer engineering ltd.

120 Iber Road, Unit 103
Stittsville, ON K2S 1E9

direct: (613) 836-0626
cell: (613) 222-9493
email: afobert@DSEL.ca

This email, including any attachments, is for the sole use of the intended recipient(s) and may contain private, confidential, and privileged information. Any unauthorized review, use, disclosure, or distribution is prohibited. If you are not the intended recipient or if this information has been inappropriately forwarded to you, please contact the sender by reply email and destroy all copies of the original.

This e-mail originates from the City of Ottawa e-mail system. Any distribution, use or copying of this e-mail or the information it contains by other than the intended recipient(s) is unauthorized. Thank you.

Le présent courriel a été expédié par le système de courriels de la Ville d'Ottawa. Toute distribution, utilisation ou reproduction du courriel ou des renseignements qui s'y trouvent par une personne autre que son destinataire prévu est interdite. Je vous remercie de votre collaboration.

This e-mail originates from the City of Ottawa e-mail system. Any distribution, use or copying of this e-mail or the information it contains by other than the intended recipient(s) is unauthorized. Thank you.

Le présent courriel a été expédié par le système de courriels de la Ville d'Ottawa. Toute distribution, utilisation ou reproduction du courriel ou des renseignements qui s'y trouvent par une personne autre que son destinataire prévu est interdite. Je vous remercie de votre collaboration.

Steve Merrick

To: Mottalib, Abdul
Subject: RE: 717: Windmill Zibi - Preliminary responses to City comments

From: Mottalib, Abdul [mailto:Abdul.Mottalib@ottawa.ca]
Sent: January-12-16 4:16 PM
To: 'Steve Merrick' <smerrick@dsel.ca>
Cc: 'Dan Clement' <dan@windmilldevelopments.com>; Scott Bentley <scottbentley@windmilldevelopments.com>; 'Kristen Jorgensen' <kristen@windmilldevelopments.com>; 'Miguel Tremblay' <tremblay@fotenn.com>; Paul Black <black@fotenn.com>; Nitsche, Kersten <Kersten.Nitsche@ottawa.ca>; Buchanan, Richard <Richard.Buchanan@ottawa.ca>; Adam Fobert <afobert@dsel.ca>; Mottalib, Abdul <Abdul.Mottalib@ottawa.ca>
Subject: RE: 717: Windmill Zibi - Preliminary responses to City comments

Hi Steve,

We have reviewed the sketch and we are okay with the fire hydrant locations as shown on the sketch. We are also fine with the maximum fire flow rate shown on the sketch provided the shown flow is available during firefighting. The consultant has to discuss this issue in detail with respect to their water model created for the site in the related section of the revised study.

Regarding item 3:

We are still reviewing this concern and will get back to you as soon as possible.

Thanks,

Abdul Mottalib, P. Eng.

From: Steve Merrick [mailto:smerrick@dsel.ca]
Sent: January 07, 2016 2:31 PM
To: Mottalib, Abdul
Cc: 'Dan Clement'; Scott Bentley; 'Kristen Jorgensen'; 'Miguel Tremblay'; Paul Black; Nitsche, Kersten; Buchanan, Richard; Adam Fobert
Subject: RE: 717: Windmill Zibi - Preliminary responses to City comments

Hi Abdul,

To follow up on our meeting yesterday, please find attached sketch showing hydrant locations and proximity of the buildings to be serviced. The sketch also indicates the maximum flow rate proposed at each hydrant.

Feel free to call to discuss if you have any questions or concerns.

Steve Merrick, EIT.
Project Coordinator / Junior Designer

DSEL
david schaeffer engineering ltd.

120 Iber Road, Unit 103

Stittsville, ON K2S 1E9

phone: (613) 836-0856 ext. 561

cell: (613) 222-7816

email: smerrick@DSEL.ca

This email, including any attachments, is for the sole use of the intended recipient(s) and may contain private, confidential, and privileged information. Any unauthorized review, use, disclosure, or distribution is prohibited. If you are not the intended recipient, or if this information has been inappropriately forwarded to you, please contact the sender by reply email and destroy all copies of the original.

APPENDIX B

Water Supply

**Windmill
Zibi - Ontario
Phase 1A**

Water Demand Design Flows per Unit Count
City of Ottawa - Water Distribution Guidelines, July 2010



Phase	Block	Type	Unit Rate	No. of Units	Avg Day L/min	Max Day L/min	Peak Hour L/min
1A	208	Office	75 L/9.3m ² /d	975	5.5	8.2	14.8
1A	208	Retail	2.5 L/m ² /d	736	1.3	1.9	3.5
1	208	Restaurant	125 L/seat/d	8	0.7	1.0	1.9
1A	205A	Res	474.6 L/unit/d	71	23.4	114.7	173.2
1A	205A	Retail	2.5 L/m ² /d	754	1.3	2.0	3.5
EO	1	Office	75 L/p/d	12	0.6	0.9	1.7
				Total	32.8	128.7	198.5

Notes:

- * Development stats per Windmill schedule dated 2016-02-01 and additional information received via email 2016-02-08.
- * Office unit rate per Ontario Building Code 8.2.1.3.B. Assuming 1 employee per 9.3m² of floor space.
- * Residential Unit rate assuming 65% one bedroom (1.4p/unit), 30% two bedroom (2.1 p/unit), 5% three bedroom (3.0p/unit)
- * Number of Residential units estimated as 850gfa / unit per Windmill development stats dated 2016-02-01.
- * Windmill estimated maximum number of employees occupying Albert Island
- * Energy Ottawa maximum employees to work at Chaudiere Office provided by EO via letter dated March 1, 2016

	Max Day PF	Peak Hour PF
Estimated Total Residential Population	128	4.9
		7.4

Windmill
Zibi - Ontario
FUS Calculations - Building 205A



Fire Flow Estimation per Fire Underwriters Survey

Water Supply For Public Fire Protection - 1999

Fire Flow Required

1. Base Requirement

$$F = 220C\sqrt{A} \quad \text{L/min} \quad \text{Where } F \text{ is the fire flow, } C \text{ is the Type of construction and } A \text{ is the Total floor area}$$

Type of Construction: Ordinary Construction

C 1 *Type of Construction Coefficient per FUS Part II, Section 1*
A 6575.1 *m² Total floor area based on FUS Part II section 1*

Fire Flow	17839.1 L/min
	18000.0 L/min <i>rounded to the nearest 1,000 L/min</i>

Adjustments

2. Reduction for Occupancy Type

Limited Combustible -15%

Fire Flow	15300.0 L/min
------------------	----------------------

3. Reduction for Sprinkler Protection

Sprinklered -30%

Reduction	-4590 L/min
------------------	--------------------

4. Increase for Separation Distance

Cons. of Exposed Wall	S.D	Lw	Ha	LH	EC	
N Ordinary - Unprotected Openings	>45m	72		0	0	0%
S Ordinary - Unprotected Openings	20.1m-30m	72		0	0	6%
E Ordinary - Unprotected Openings	3.1m-10m	26		0	0	15%
W Ordinary - Unprotected Openings	3.1m-10m	26		0	0	15%
	% Increase				36%	<i>value not to exceed 75%</i>

Increase	5508.0 L/min
-----------------	---------------------

Lw = Length of the Exposed Wall

Ha = number of storeys of the adjacent structure

LH = Length-height factor of exposed wall. Value rounded up.

EC = Exposure Charge

Total Fire Flow

Fire Flow	16218.0 L/min	<i>fire flow not to exceed 45,000 L/min nor be less than 2,000 L/min per FUS Section</i>
	16000.0 L/min	<i>rounded to the nearest 1,000 L/min</i>

Notes:

-Type of construction, Occupancy Type and Sprinkler Protection information provided by _____.

-Calculations based on Fire Underwriters Survey - Part II

**Windmill
Zibi - Ontario
FUS Calculations - Building 208**



Fire Flow Estimation per Fire Underwriters Survey

Water Supply For Public Fire Protection - 1999

Fire Flow Required

1. Base Requirement

$$F = 220C\sqrt{A}$$

L/min Where *F* is the fire flow, *C* is the Type of construction and *A* is the Total floor area

Type of Construction: Ordinary Construction

C 1 Type of Construction Coefficient per FUS Part II, Section 1
A 1711.8 m² Total floor area based on FUS Part II section 1

Fire Flow	9102.3 L/min
	9000.0 L/min rounded to the nearest 1,000 L/min

Adjustments

2. Reduction for Occupancy Type

Limited Combustible -15%

Fire Flow	7650.0 L/min
------------------	---------------------

3. Reduction for Sprinkler Protection

Sprinklered -30%

Reduction	-2295 L/min
------------------	--------------------

4. Increase for Separation Distance

Cons. of Exposed Wall	S.D	Lw	Ha	LH	EC	
N Ordinary - Unprotected Openings	20.1m-30m	30		0	0	6%
S Ordinary - Unprotected Openings	20.1m-30m	30		0	0	6%
E Ordinary - Unprotected Openings	10.1m-20m	28		0	0	10%
W Ordinary - Unprotected Openings	3.1m-10m	30		3	90	18%
	% Increase				40%	value not to exceed 75%

Increase	3060.0 L/min
-----------------	---------------------

Lw = Length of the Exposed Wall

Ha = number of storeys of the adjacent structure

LH = Length-height factor of exposed wall. Value rounded up.

EC = Exposure Charge

Total Fire Flow

Fire Flow	8415.0 L/min	<i>fire flow not to exceed 45,000 L/min nor be less than 2,000 L/min per FUS Section</i>
	8000.0 L/min	<i>rounded to the nearest 1,000 L/min</i>

Notes:

-Type of construction, Occupancy Type and Sprinkler Protection information provided by _____.

-Calculations based on Fire Underwriters Survey - Part II

Steve Merrick

Subject: RE: Chaudiere/Albert Island Development - Water Boundary Condition Request

From: Bazinet, Kristin [mailto:Kristin.Bazinet@ottawa.ca]
Sent: August-04-15 7:30 AM
To: Steve Merrick <smerrick@dsel.ca>; 'Adam Fobert' <afobert@DSEL.ca>
Cc: Buchanan, Richard <Richard.Buchanan@ottawa.ca>; Mottalib, Abdul <Abdul.Mottalib@ottawa.ca>
Subject: FW: Chaudiere/Albert Island Development - Water Boundary Condition Request

Hi Steve – find attached the boundary conditions as requested.

Thanks,
Kristin

Kristin Bazinet. P.Eng
Development Review
Examen des demandes d'aménagement



City of Ottawa | Ville d'Ottawa
613.580.2424 ext./poste 12180
ottawa.ca/planning / ottawa.ca/urbanisme

The following are boundary conditions, HGL, for hydraulic analysis at the Chaudière/Albert Islands Phase 1 (Pressure Zone 1W), assumed to be connected to (see attached PDF for location):

- 1) 406mm on Wellington
- 2) 305mm on Booth

Minimum HGL = 108.0m (same at both locations)

Maximum HGL = 115.1m (same at both locations), the maximum pressure is estimated to be greater than 80 psi. A pressure check at completion of construction is recommended to determine if pressure control is required.

Fire Flow*	Connection 1 (Wellington)
150 L/s	110.7m
217 L/s	110.1m
250 L/s	109.8m

300 L/s	109.2m
367 L/s	108.3m

*Includes Max Day demands of 2.49 L/s distributed evenly between both connection points (i.e. 1.75L/s at each connection point)

Fire Flow*	Connection 2 (Booth)
150 L/s	109.4m
217 L/s	107.4m
250 L/s	106.3m
300 L/s	104.2m
367 L/s	101.1m

*Includes Max Day demands of 2.49 L/s distributed evenly between both connection points (i.e. 1.75 L/s at each connection point)

These are for current conditions and are based on computer model simulation.

Disclaimer: The boundary condition information is based on current operation of the city water distribution system. The computer model simulation is based on the best information available at the time. The operation of the water distribution system can change on a regular basis, resulting in a variation in boundary conditions. The physical properties of watermains deteriorate over time, as such must be assumed in the absence of actual field test data. The variation in physical watermain properties can therefore alter the results of the computer model simulation.

From: Buchanan, Richard
Sent: July 28, 2015 2:46 PM
To: Bazinet, Kristin
Subject: FW: Chaudiere/Albert Island Development - Water Boundary Condition Request

Can you send this in for the boundary conditions and forward to DSEL?

Richard Buchanan, CET
 Program Manager, Development Review
 (Urban Services) Outer
 Gestionnaire de programme
 (Secteur urbain) Extérieur



City of Ottawa | Ville d'Ottawa
 ☎ 613.580.2424 ext./poste 27801

From: Steve Merrick [<mailto:smerrick@dsel.ca>]
Sent: July-28-15 1:17 PM
To: Abdul <Abdul.Mottalib@ottawa.ca>
Cc: Adam Fobert <afobert@dsel.ca>
Subject: RE: Chaudiere/Albert Island Development - Water Boundary Condition Request

Hi Abdul,

We require updated boundary conditions for Phase 1 of the above noted development. The connection locations are consistent with previous requests. Anticipated demands are as follows:

	L/min	L/s
Avg. Daily	69.6	1.16
Max Day	149.4	2.49
Peak Hour	228.7	3.81

Max Day + Fire Flow = 149.4 + 20,000 L/min

I hope you can expedite this process we are looking to submit as soon as possible.

Steve Merrick, EIT.
Project Coordinator / Junior Designer

DSEL

David Schaeffer Engineering Ltd.

120 Iber Road, Unit 103
Stittsville, ON K2S 1E9

phone: (613) 836-0856 ext. 561
fax: (613) 836-7183
email: smerrick@DSEL.ca

This email, including any attachments, is for the sole use of the intended recipient(s) and may contain private, confidential, and privileged information. Any unauthorized review, use, disclosure, or distribution is prohibited. If you are not the intended recipient, or if this information has been inappropriately forwarded to you, please contact the sender by reply email and destroy all copies of the original.

Boundary Condition for Chaudiere/Albert Islands

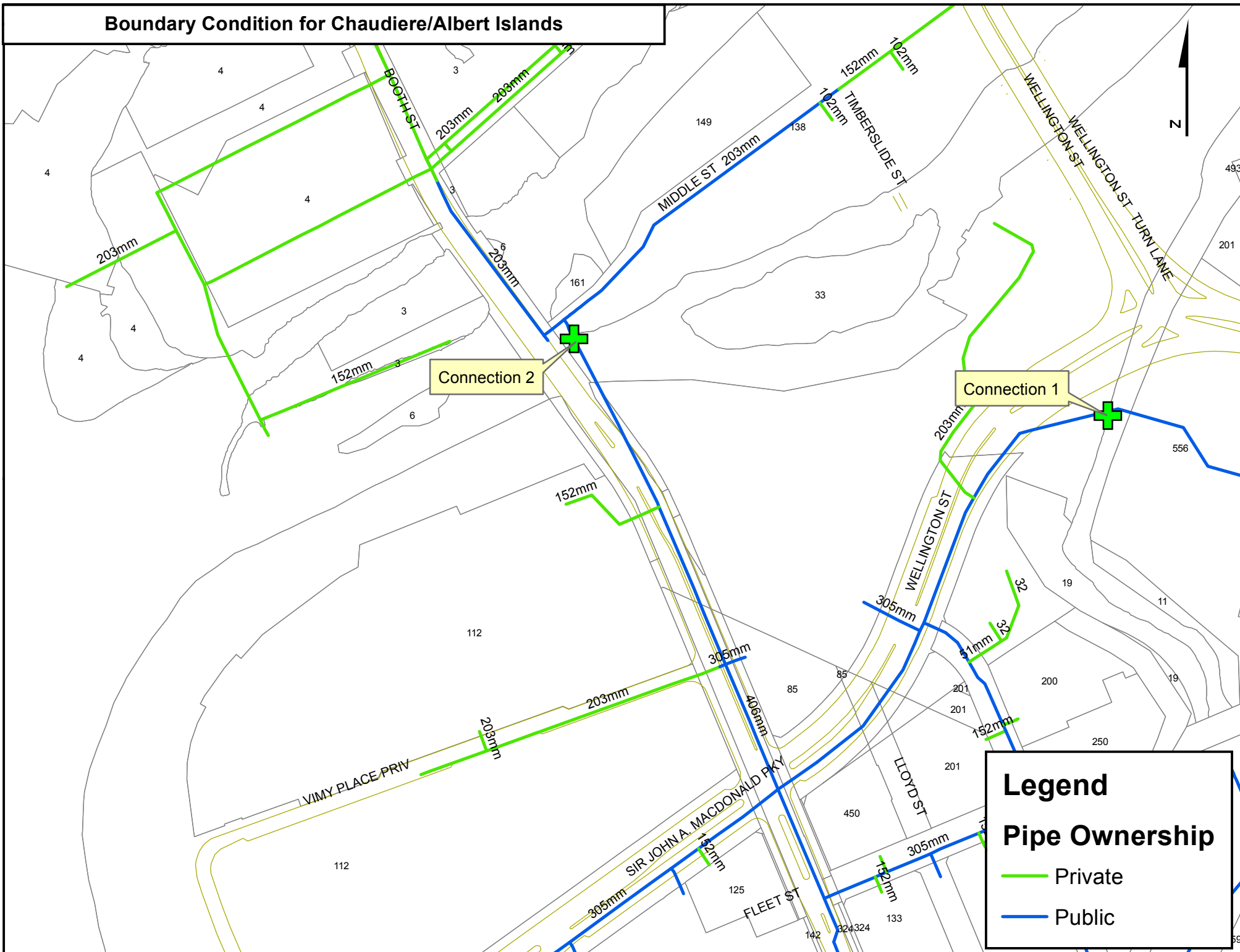

Legend

Pipe Ownership

- Private
- Public

Average Daily Demand

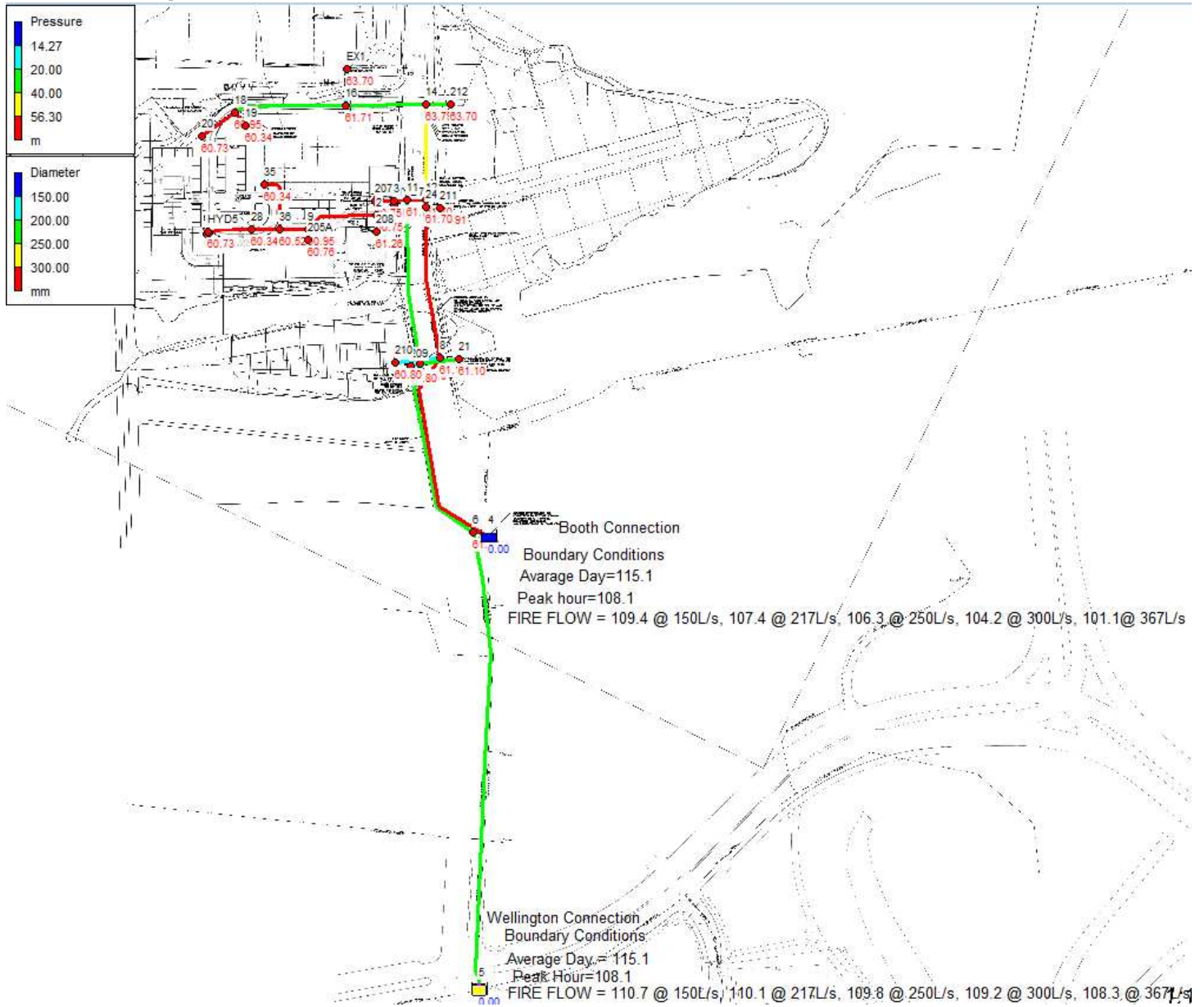

```

*****
*                               E P A N E T                               *
*                               Hydraulic and Water Quality                 *
*                               Analysis for Pipe Networks                   *
*                               Version 2.0                                 *
*****
    
```

Input File: 2018-05-24_717_ggm.net

Link - Node Table:

Link ID	Start Node	End Node	Length m	Diameter mm
1	5	6	270	200
2	6	7	130	200
3	4	8	130	300
4	7	209	15	150
5	7	11	190	200
6	8	24	98	300
7	12	11	17	300
8	11	3	17	300
9	HYD7	3	3	150
10	207	3	39	300
11	12	14	76	250
12	14	212	28	200
13	14	16	48.45	200
14	16	EX1	8.57	150
17	18	19	10	300
18	20	18	24.2	300
19	21	7	1.5	200
20	8	210	1.5	150
21	16	18	67.72	200
22	211	24	8.9	250
23	24	12	4.2	300
26	205B	30	1.9	300
27	30	HYD5	0.65	150
28	30	28	27.55	300
29	28	36	16.4	300
30	36	35	35.2	300
31	36	9	17.8	300
32	9	2	42.7	300
33	2	207	9.5	300
39	9	205A	15	150
40	2	208	15	150



Page 2

Node Results:

Node ID	Demand LPM	Head m	Pressure m	Quality
HYD7	0.00	115.10	60.95	0.00
3	0.00	115.10	61.00	0.00
6	0.00	115.10	61.20	0.00
7	0.00	115.10	61.10	0.00
8	0.00	115.10	61.10	0.00
209	0.00	115.10	60.80	0.00
11	0.00	115.10	61.70	0.00
12	0.00	115.10	61.70	0.00
207	0.00	115.10	60.75	0.00
14	0.00	115.10	63.79	0.00
212	0.00	115.10	63.70	0.00
16	0.00	115.10	61.71	0.00
EX1	0.60	115.10	63.70	0.00
18	0.00	115.10	60.95	0.00
19	0.00	115.10	60.34	0.00
20	0.00	115.10	60.73	0.00
21	0.00	115.10	61.10	0.00
210	0.00	115.10	60.80	0.00
211	0.00	115.10	61.91	0.00
24	0.00	115.10	61.70	0.00
28	0.00	115.10	60.34	0.00
205B	0.00	115.10	61.06	0.00
30	0.00	115.10	61.06	0.00
HYD5	0.00	115.10	60.73	0.00
9	0.00	115.10	60.95	0.00
2	0.00	115.10	60.75	0.00
35	0.00	115.10	60.34	0.00
36	0.00	115.10	60.52	0.00
205A	24.70	115.10	60.76	0.00
208	7.40	115.10	61.26	0.00
4	-27.86	115.10	0.00	0.00 Reservoir
5	-4.86	115.10	0.00	0.00 Reservoir

Link Results:

Link ID	Flow LPM	Velocity m/s	Headloss m/km	Status
1	4.86	0.00	0.00	Open

2	4.86	0.00	0.00	Open
3	27.86	0.01	0.00	Open
4	0.00	0.00	0.00	Open
5	4.86	0.00	0.00	Open
6	27.86	0.01	0.00	Open
7	27.25	0.01	0.00	Open
8	32.11	0.01	0.00	Open
9	0.00	0.00	0.00	Open



Page 3

Link Results: (continued)

Link ID	Flow LPM	Velocity m/s	Unit Headloss m/km	Status
10	-32.11	0.01	0.00	Open
11	0.60	0.00	0.00	Open
12	0.00	0.00	0.00	Open
13	0.60	0.00	0.00	Open
14	0.60	0.00	0.00	Open
17	0.00	0.00	0.00	Open
18	0.00	0.00	0.00	Open
19	0.00	0.00	0.00	Open
20	0.00	0.00	0.00	Open
21	0.00	0.00	0.00	Open
22	0.00	0.00	0.00	Open
23	27.85	0.01	0.00	Open
26	0.00	0.00	0.00	Open
27	0.00	0.00	0.00	Open
28	0.00	0.00	0.00	Open
29	0.00	0.00	0.00	Open
30	0.00	0.00	0.00	Open
31	-0.01	0.00	0.00	Open
32	-24.71	0.01	0.00	Open
33	-32.11	0.01	0.00	Open
39	24.70	0.02	0.02	Open
40	7.40	0.01	0.00	Open

Max. Day + Fire Flow

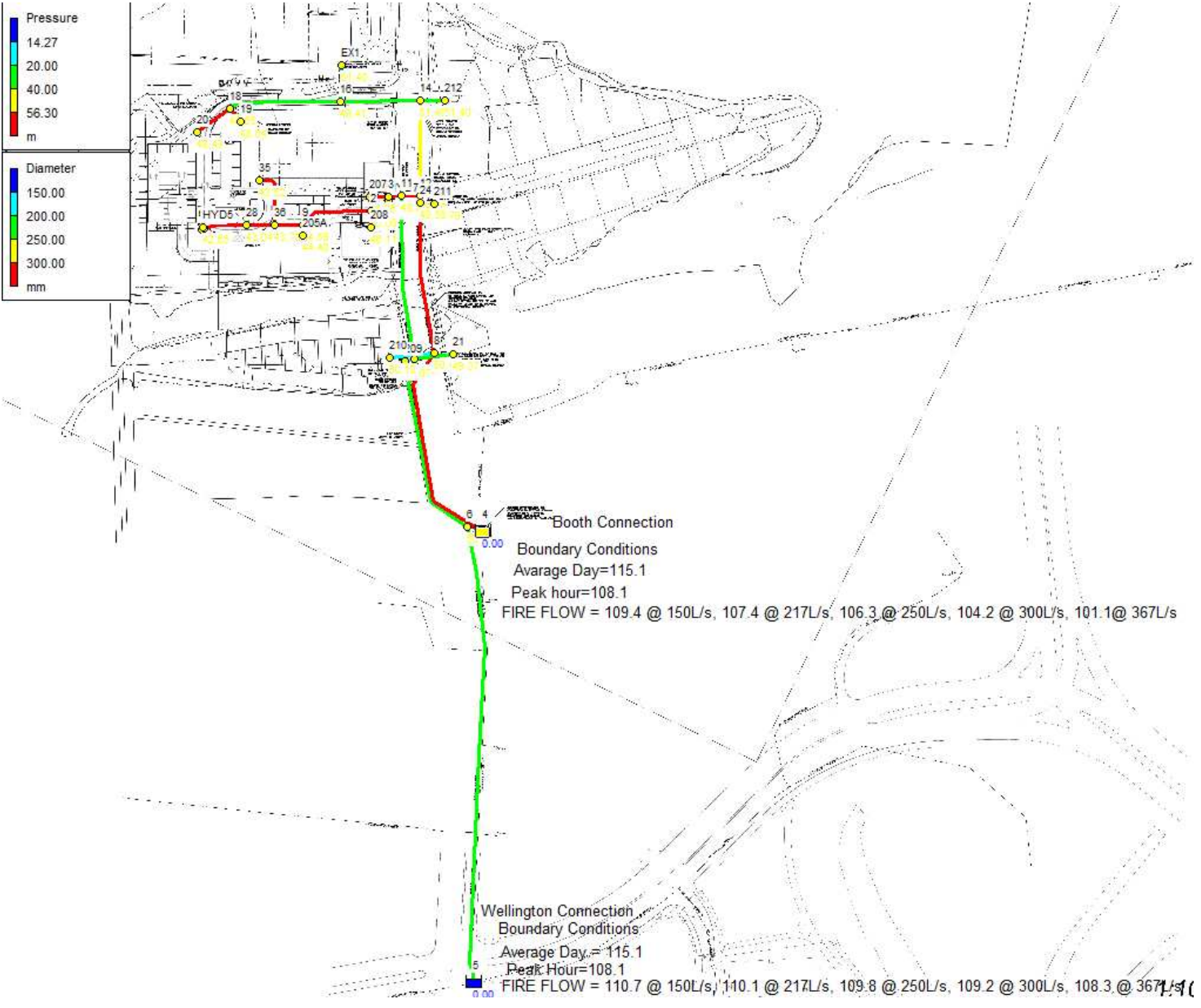

```
*****
*                               E P A N E T                               *
*                               Hydraulic and Water Quality                 *
*                               Analysis for Pipe Networks                   *
*                               Version 2.0                                 *
*****
```

Input File: 2018-05-24_717_ggm.net

Link - Node Table:

Link ID	Start Node	End Node	Length m	Diameter mm
1	5	6	270	200
2	6	7	130	200
3	4	8	130	300
4	7	209	15	150
5	7	11	190	200
6	8	24	98	300
7	12	11	17	300
8	11	3	17	300
9	HYD7	3	3	150
10	207	3	39	300
11	12	14	76	250
12	14	212	28	200
13	14	16	48.45	200
14	16	EX1	8.57	150
17	18	19	10	300
18	20	18	24.2	300
19	21	7	1.5	200
20	8	210	1.5	150
21	16	18	67.72	200
22	211	24	8.9	250
23	24	12	4.2	300
26	205B	30	1.9	300
27	30	HYD5	0.65	150
28	30	28	27.55	300
29	28	36	16.4	300
30	36	35	35.2	300
31	36	9	17.8	300
32	9	2	42.7	300
33	2	207	9.5	300
39	9	205A	15	150
40	2	208	15	150



Page 2

Node Results:

Node ID	Demand LPM	Head m	Pressure m	Quality
HYD7	0.00	101.34	47.19	0.00
3	0.00	101.34	47.24	0.00
6	0.00	104.37	50.47	0.00
7	0.00	103.37	49.37	0.00
8	0.00	104.48	50.48	0.00
209	0.00	103.37	49.07	0.00
11	0.00	102.20	48.80	0.00
12	0.00	102.80	49.40	0.00
207	0.00	100.40	46.05	0.00
14	0.00	102.80	51.49	0.00
212	0.00	102.80	51.40	0.00
16	0.00	102.80	49.41	0.00
EX1	0.90	102.80	51.40	0.00
18	0.00	102.80	48.65	0.00
19	0.00	102.80	48.04	0.00
20	0.00	102.80	48.43	0.00
21	0.00	103.37	49.37	0.00
210	0.00	104.48	50.18	0.00
211	0.00	102.98	49.79	0.00
24	0.00	102.98	49.58	0.00
28	0.00	97.80	43.04	0.00
205B	0.00	97.02	42.98	0.00
30	10000.00	97.02	42.98	0.00
HYD5	0.00	97.02	42.65	0.00
9	0.00	98.74	44.59	0.00
2	0.00	99.95	45.60	0.00
35	0.00	98.28	43.52	0.00
36	0.00	98.28	43.70	0.00
205A	116.60	98.74	44.40	0.00
208	11.20	99.95	46.11	0.00
4	-8449.85	107.40	0.00	0.00 Reservoir
5	-1678.86	110.10	0.00	0.00 Reservoir

Link Results:

Link ID	Flow LPM	Velocity m/s	Headloss m/km	Status
1	1678.86	0.89	21.23	Open

2	1678.86	0.89	7.64	Open
3	8449.85	1.99	22.45	Open
4	0.00	0.00	0.00	Open
5	1678.86	0.89	6.18	Open
6	8449.85	1.99	15.29	Open
7	8448.94	1.99	35.45	Open
8	10127.80	2.39	50.41	Open
9	0.00	0.00	0.00	Open



Page 3

Link Results: (continued)

Link ID	Flow LPM	Velocity m/s	Headloss m/km	Status
10	-10127.80	2.39	24.12	Open
11	0.90	0.00	0.00	Open
12	0.00	0.00	0.00	Open
13	0.90	0.00	0.00	Open
14	0.90	0.00	0.00	Open
17	0.00	0.00	0.00	Open
18	0.00	0.00	0.00	Open
19	0.00	0.00	0.00	Open
20	0.00	0.00	0.00	Open
21	0.00	0.00	0.00	Open
22	0.00	0.00	0.00	Open
23	8449.85	1.99	42.94	Open
26	0.00	0.00	0.00	Open
27	0.00	0.00	0.00	Open
28	-10000.00	2.36	28.45	Open
29	-10000.00	2.36	29.56	Open
30	0.00	0.00	0.00	Open
31	-10000.00	2.36	25.56	Open
32	-10116.60	2.39	28.44	Open
33	-10127.80	2.39	47.17	Open
39	116.60	0.11	0.29	Open
40	11.20	0.01	0.00	Open

Peak Hour Demand

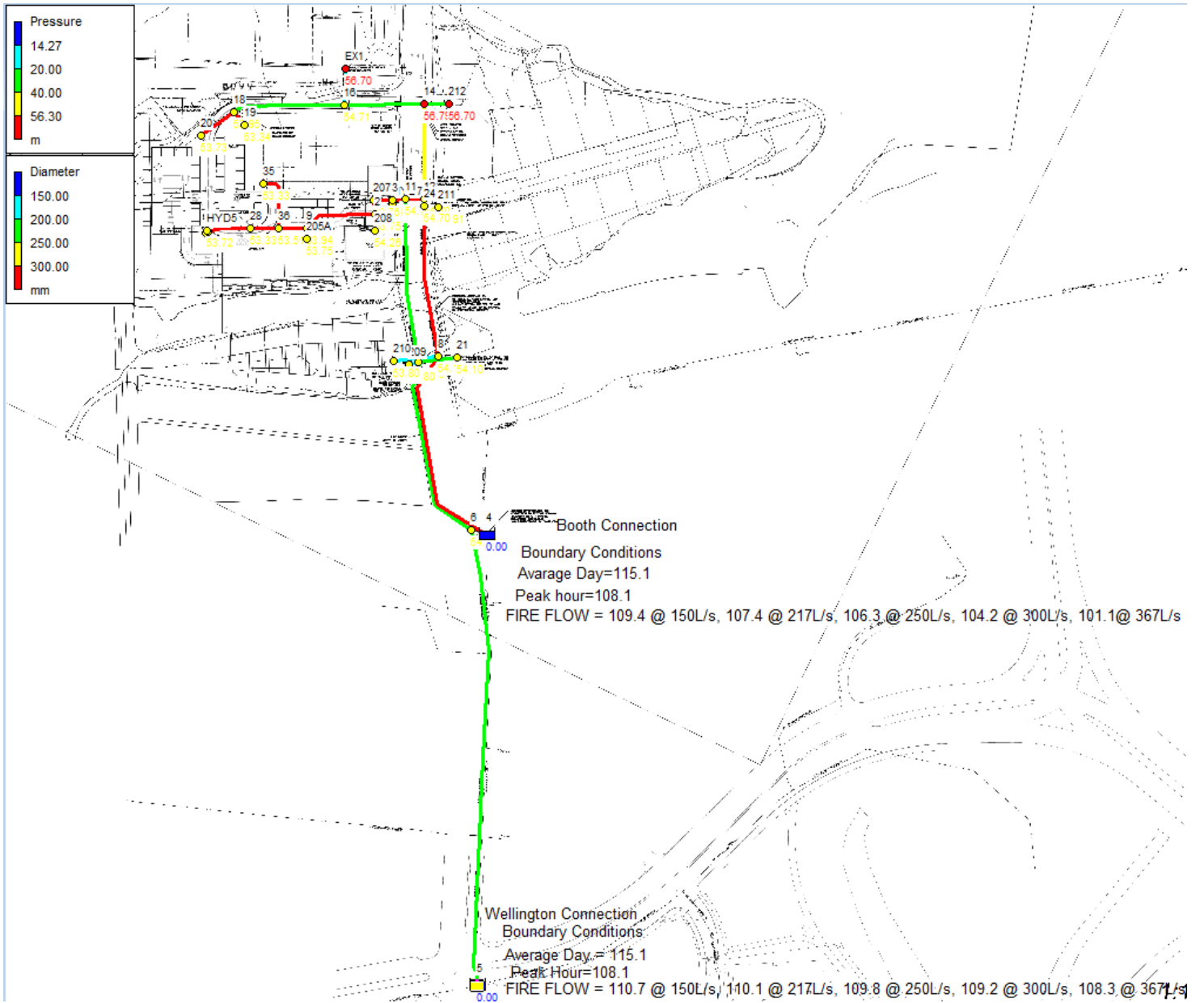

```
*****
*                               E P A N E T                               *
*                               Hydraulic and Water Quality              *
*                               Analysis for Pipe Networks                *
*                               Version 2.0                              *
*****
```

Input File: 2018-05-24_717_ggm.net

Link - Node Table:

Link ID	Start Node	End Node	Length m	Diameter mm
1	5	6	270	200
2	6	7	130	200
3	4	8	130	300
4	7	209	15	150
5	7	11	190	200
6	8	24	98	300
7	12	11	17	300
8	11	3	17	300
9	HYD7	3	3	150
10	207	3	39	300
11	12	14	76	250
12	14	212	28	200
13	14	16	48.45	200
14	16	EX1	8.57	150
17	18	19	10	300
18	20	18	24.2	300
19	21	7	1.5	200
20	8	210	1.5	150
21	16	18	67.72	200
22	211	24	8.9	250
23	24	12	4.2	300
26	205B	30	1.9	300
27	30	HYD5	0.65	150
28	30	28	27.55	300
29	28	36	16.4	300
30	36	35	35.2	300
31	36	9	17.8	300
32	9	2	42.7	300
33	2	207	9.5	300
39	9	205A	15	150
40	2	208	15	150



Page 2

Node Results:

Node ID	Demand LPM	Head m	Pressure m	Quality
HYD7	0.00	108.10	53.95	0.00
3	0.00	108.10	54.00	0.00
6	0.00	108.10	54.20	0.00
7	0.00	108.10	54.10	0.00
8	0.00	108.10	54.10	0.00
209	0.00	108.10	53.80	0.00
11	0.00	108.10	54.70	0.00
12	0.00	108.10	54.70	0.00
207	0.00	108.10	53.75	0.00
14	0.00	108.10	56.79	0.00
212	0.00	108.10	56.70	0.00
16	0.00	108.10	54.71	0.00
EX1	1.70	108.10	56.70	0.00
18	0.00	108.10	53.95	0.00
19	0.00	108.10	53.34	0.00
20	0.00	108.10	53.73	0.00
21	0.00	108.10	54.10	0.00
210	0.00	108.10	53.80	0.00
211	0.00	108.10	54.91	0.00
24	0.00	108.10	54.70	0.00
28	0.00	108.09	53.33	0.00
205B	0.00	108.09	54.05	0.00
30	0.00	108.09	54.05	0.00
HYD5	0.00	108.09	53.72	0.00
9	0.00	108.09	53.94	0.00
2	0.00	108.10	53.75	0.00
35	0.00	108.09	53.33	0.00
36	0.00	108.09	53.51	0.00
205A	176.70	108.09	53.75	0.00
208	20.10	108.10	54.26	0.00
4	-169.63	108.10	0.00	0.00 Reservoir
5	-28.87	108.10	0.00	0.00 Reservoir

Link Results:

Link ID	Flow LPM	Velocity m/s	Unit Headloss m/km	Status
1	28.87	0.02	0.01	Open

2018-06-15_717_peak.rpt

2	28.87	0.02	0.00	Open
3	169.63	0.04	0.01	Open
4	0.00	0.00	0.00	Open
5	28.87	0.02	0.00	Open
6	169.63	0.04	0.01	Open
7	167.93	0.04	0.02	Open
8	196.80	0.05	0.03	Open
9	0.00	0.00	0.00	Open



Page 3

Link Results: (continued)

Link ID	Flow LPM	Velocity m/s	Unit Headloss m/km	Status
10	-196.80	0.05	0.02	Open
11	1.70	0.00	0.00	Open
12	0.00	0.00	0.00	Open
13	1.70	0.00	0.00	Open
14	1.70	0.00	0.00	Open
17	0.00	0.00	0.00	Open
18	0.00	0.00	0.00	Open
19	0.00	0.00	0.00	Open
20	0.00	0.00	0.00	Open
21	0.00	0.00	0.00	Open
22	0.00	0.00	0.00	Open
23	169.63	0.04	0.02	Open
26	0.00	0.00	0.00	Open
27	0.00	0.00	0.00	Open
28	0.00	0.00	0.00	Open
29	0.00	0.00	0.00	Open
30	0.00	0.00	0.00	Open
31	0.00	0.00	0.00	Open
32	-176.70	0.04	0.01	Open
33	-196.80	0.05	0.02	Open
39	176.70	0.17	0.64	Open
40	20.10	0.02	0.01	Open

APPENDIX C

Wastewater Collection

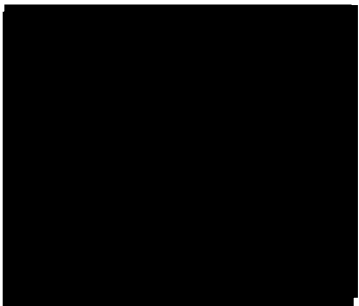

SANITARY SEWER CALCULATION SHEET

PROJECT: **Zibi Ontario**
 LOCATION: **4 Booth Street**
 FILE REF: **717**
 DATE: **1-Aug-18**

DESIGN PARAMETERS

Avg. Daily Flow Res. 280 L/p/d
 Avg. Daily Flow Comm 28,000 L/ha/d
 Avg. Daily Flow Instit. 28,000 L/ha/d
 Avg. Daily Flow Indust 55,000 L/ha/d

Peak Fact Res. Per Harmons: Min = 2.0, Max =3.8
 Peak Fact. Comm. 1.5
 Peak Fact. Instit. 1.5
 Peak Fact. Indust. per MOE graph

Infiltration / Inflow 0.33 L/s/ha
 Min. Pipe Velocity 0.60 m/s full flowing
 Max. Pipe Velocity 3.00 m/s full flowing
 Mannings N 0.013



Location			Residential Area and Population					Commercial	Institutional	Industrial	Infiltration			Pipe Data													
Area ID	Up	Down	Area	Pop.	Cumulative	Peak.	Q _{res}	Area	Accu.	Area	Accu.	Area	Accu.	Q _{C+I+I}	Total	Accu.	Infiltration	Total	DIA	Slope	Length	A _{hydraulic}	R	Velocity	Q _{cap}	Q / Q full	
			(ha)		Area (ha)	Pop. (-)	(L/s)	(ha)	(ha)	(ha)	(ha)	(ha)	(ha)	(L/s)	(ha)	(ha)	(L/s)	(L/s)	(mm)	(%)	(m)	(m ²)	(m)	(m/s)	(L/s)	(-)	
From Perley Street																											
	SAN106	SAN105	0.000	0.0	0.000	0.0	3.80	0.00	0.00	0.00	0.00	0.00	0.00	0.0	0.000	0.000	0.000	0.00	250	1.00	22.2	0.049	0.063	1.21	59.5	0.00	
	SAN105	SAN104	0.000	0.0	0.000	0.0	3.80	0.00	0.00	0.00	0.00	0.00	0.00	0.0	0.000	0.000	0.000	0.00	250	1.10	9.2	0.049	0.063	1.27	62.4	0.00	
EO OFFICE	SAN104	SAN103	0.000	0.0	0.000	0.0	3.80	0.00	0.00	0.00	0.00	0.00	0.00	0.0	0.000	0.000	0.000	0.02	250	1.50	107.8	0.049	0.063	1.48	72.8	0.00	
	SAN103	SAN102	0.000	0.0	0.000	0.0	3.80	0.00	0.00	0.00	0.00	0.00	0.00	0.0	0.000	0.000	0.000	0.02	250	0.42	67.3	0.049	0.063	0.79	38.5	0.00	
From Albert Island																											
	SAN303	SAN302	0.000	0.0	0.000	0.0	3.80	0.00	0.00	0.00	0.00	0.00	0.00	0.0	0.000	0.000	0.000	0.00	250	0.35	15.7	0.049	0.063	0.72	35.2	0.00	
	SAN302	SAN301	0.000	0.0	0.000	0.0	3.80	0.00	0.00	0.00	0.00	0.00	0.00	0.0	0.000	0.000	0.000	0.00	250	0.35	57.3	0.049	0.063	0.72	35.2	0.00	
	SAN301	SAN102	0.000	0.0	0.000	0.0	3.80	0.00	0.00	0.00	0.00	0.00	0.00	0.0	0.000	0.000	0.000	0.00	250	2.00	37.0	0.049	0.063	1.71	84.1	0.00	
205A, 208	SAN102	SAN101	1.090	71.0	1.090	71.0	3.63	1.39	0.00	0.00	0.00	0.00	0.4	1.090	1.090	0.360	2.16	250	0.45	12.4	0.049	0.063	0.81	39.9	0.05		
	SAN101	PS	0.000	0.0	1.090	71.0	3.63	1.39	0.00	0.00	0.00	0.00	0.4	0.000	1.090	0.360	2.16	250	0.32	6.9	0.049	0.063	0.69	33.6	0.06		
LRT Crossing																											
	SANMH1001	SANMH1002	0.000	0.0	1.090	71.0	3.63	1.39	0.00	0.00	0.00	0.00	0.4	1.090	1.090	0.360	2.16	300	0.65	16.6	0.071	0.075	1.10	78.0	0.03		
	SANMH1002	SANMH1003	0.000	0.0	1.090	71.0	3.63	1.39	0.00	0.00	0.00	0.00	0.4	1.090	1.090	0.360	2.16	300	0.65	16.5	0.071	0.075	1.10	78.0	0.03		
	SANMH 1003	SANMH 1004	0.000	0.0	1.090	71.0	3.63	1.39	0.00	0.00	0.00	0.00	0.4	1.090	1.090	0.360	2.16	300	0.55	47.3	0.071	0.075	1.01	71.7	0.03		
	SANMH1004	EX SANMH	0.000	0.0	1.090	71.0	3.63	1.39	0.00	0.00	0.00	0.00	0.4	1.090	1.090	0.360	2.16	300	0.55	3.7	0.071	0.075	1.01	71.7	0.03		
NOTE: FLOW RATES FROM PHASE 1A SANITARY WASTEWATER DISCHARGE																											



To:	David Schaeffer Engineering Limited (DSEL)
Attn:	Adam Fobert, P.Eng
From:	Peter Rüsçh, P.Eng
Date:	August 13, 2015
Project #:	282834
Page(s):	4
CC:	
Subject:	Windmill Pumping Station Capacity Assessment

Dear Mr. Fobert:

HMM was retained to evaluate the capacity of an existing pumping station, located in an old paper mill building on Chaudiere Island, in Ottawa, Ontario. HMM staff visited the Pumping Station on June 30, 2015, in the presence of Steve Merrick from DSEL and Kristen Jorgensen from WINDMILL Development Group Ltd. For the purpose of this Technical Memorandum (TM) the pumping station will be called the Windmill Sanitary Pumping Station (WSPS). This analysis is based on the information gathered during the site visit and from additional sources as indicated in this TM. The pumping station is located in an old building, on the south side of Chaudiere Crossing.

In a pumping station evaluation HMM aims to confirm the duty point, and thus capacity, using more than one method, to ensure that errors / inconsistencies in the often unreliable data are discovered and discussed. These methods are:

- Confirming the flow utilizing a flow meter, if installed;
- Confirming the duty point by superimposing the pump curve onto the system curve. In this case the intersection of the pump and system curve defines the duty point and thus flow rate; and
- Confirming the duty point by measuring the power uptake of the electrical motor. It has to be noted that the power uptake of the electric motor in itself does not define the duty, however gives an indication of the duty point as it relates to the original pump curve.

Under ideal conditions, the duty points derived as noted above for the pumping station under consideration should provide for similar or very similar capacities, increasing the overall confidence in the assessment.

For the WSPS, HMM utilized the first two of the three methods noted above, and the purpose of this TM to detail the findings of both of the methods.

Confirming the flow utilizing the flow meter

The WSPS has a Endress and Hauser ProMag F flow meter with a diameter of 50mm. It appears to have been installed a considerable time ago. Photo 1 below shows the flow meter as installed and the corrosion of the flange bolts. The flow meter has more than the required 5 diameters of straight pipe upstream and downstream. The WSPS ran only once during the site



visit, and during this period a flow rate of ~88 to 90 gpm was indicated by the meter. However, it was also noted that the Flow meter readout showed a “System Error Amplifier”. HMM was not able to confirm if the flow rate indicated was measured in US or UK/Canadian gallons.



Photo 1: Flow meter: Endress + Hauser ProMag F

If the flows were measured in US gpm, the flow rate would be 5.55 L/s, however in case the flow rate is measured in UK/ Canadian gallons, the corresponding flow rate would be 6.67 L/s. Assuming that the flow meter measures the flow with reasonable accuracy given it's age it may be concluded that the flow is likely between 5.5 L/s and 6.7 L/s.

Confirming the duty point by superimposing the pump curve onto the system curve

HMM staff obtained a survey (attached to the TM) providing an approximate length of the forcemain, as well as elevation of the wet well (top of lid) and the elevation of the discharge location. From this survey the following core parameters are available for the forcemain:

- Wet Well Top of Lid Elevation – 48.6 m
- Centerline of Discharge Elevation – 51.7 m
- Length of the forcemain ~ 177 m

No material information has been noted on the survey drawing, however HMM staff noted during the site visit that the forcemain material in the building was galvanized steel, diameter 75 mm. HMM has not confirmed the material of the remainder of the forcemain, as it was not



accessible. During the site visit the operating levels of the pumps were measured from the PS lid, these were recorded as follows:

- Lead Pump On – 2.6m from Lid, or 46.0 m
- Lead Pump Off – 3.0 m from Lid, or 45.6 m

This would result in a live wet well depth of 0.4 m. HMM notes that the “Lead Pump On” level was recorded based on the concrete being wet at a certain level, and therefore may not be accurate. In the PS electrical panel there are hand written notes referring to the following (see also Photo 2 below):

- Start @ .77
- Stop @ .28

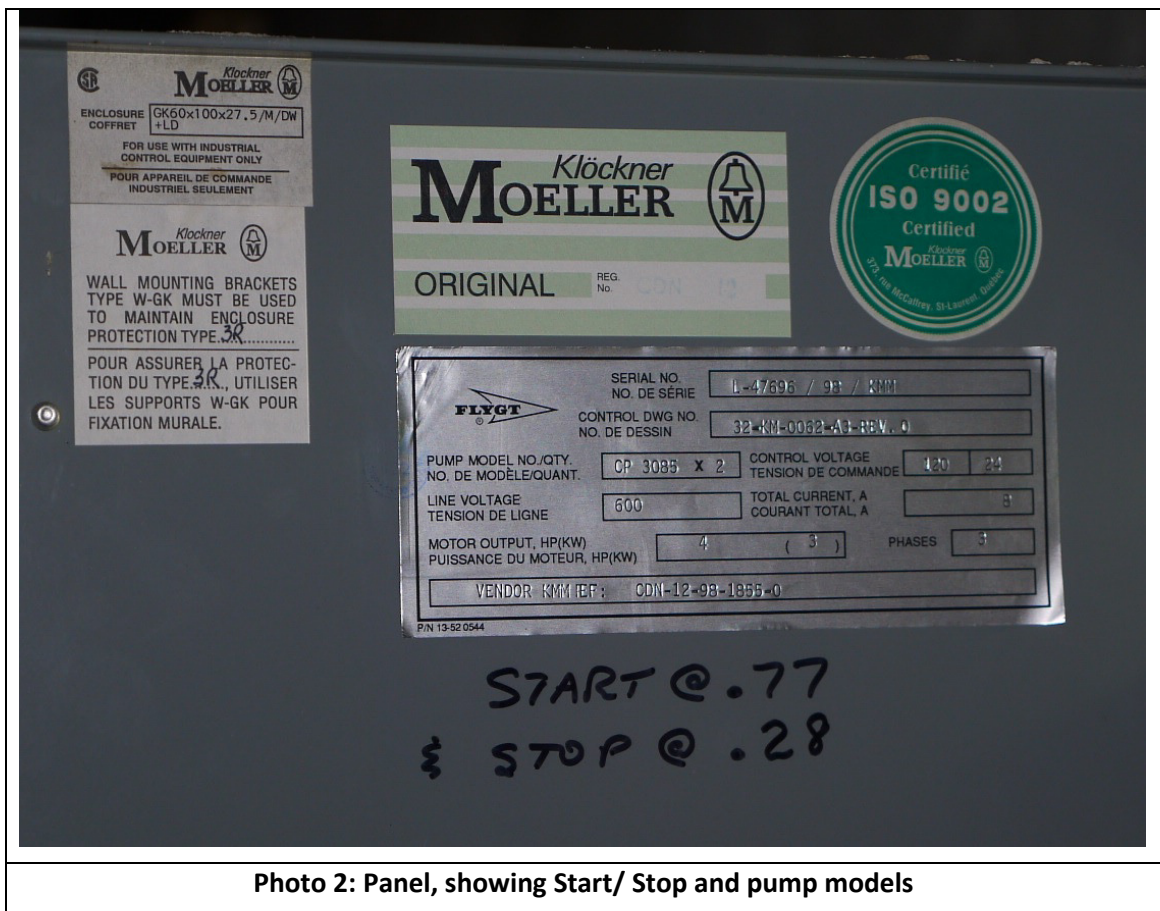

Photo 2: Panel, showing Start/ Stop and pump models

No units are noted. If in m, the resulting live wet well depth would be 0.5 m. HMM calculated the required wet well volume (based on the measured wet well dimensions), and for a flow of 6.7 L/s, this would require a live well depth of 0.5 m, disregarding volume taken by equipment.

As result in the system curve HMM used a “Lead Pump On” elevation of 46.1m.

The following parameters were used in the preparation of the system curve:

- Hazen Williams C (HWC) -factor of 90, 100 and 110: since the HWC is diameter and material dependent, and we expect the material to have some corrosion;



- Local loss factor (k) = 15, to account for fittings;
- Pipe ID is taken as 75 mm.

HMM staff has obtained a pump curve from Flygt for the pump. The pump curve was superimposed on the system curve, and extended past the posted limit. We believe that this may be valid (see also below for additional discussion on the pump) as the hydraulic efficiency was not at its maximum at the cut-off point of the curve.

The system curve with the superimposed pump curve is attached hereto. From the system curve the following observations are made:

- The 2 flow observations based on the flow meter, at 5.5 L/s and 6.7 L/s are marked as a green and black triangle respectively;
- The pump curve intersects the system curve above the black triangle;

In review of the available information, HMM noted that the Flygt panel in the PS (see Photo 2 above) notes that the pump models are CP 3085, these pumps have standard impellers. However Flygt has noted that, based on the data provided from the Flygt Tag that the pumps are DP 3085, with vortex impellers. These are less efficient than standard impellers. Based on the curve provided by Flygt it appears as if the pumps are running well past their power limitation (marked by P on the attached curve). However, in the event that the pumps are actually CP 3085 models as opposed to DP 3085, we would expect the pumps may not be overloaded. In case of the pumps running well past the power limits, HMM notes that the running times appear to be low, and that cool operation may have played a role in keeping the pumps functional.

HMM provides the following recommendations based on the currently available data:

- The flow meter should be repaired / replaced and the units confirmed to confirm the flow rate from the flow meter;
- The pumps should be lifted from the station to confirm if they are CP or DP models;
- If the pumps are CP models it is strongly suggested that the power uptake be measured under various operating condition to confirm if the pump is operating past the power limit if any.

METRIC
 DISTANCES AND ELEVATIONS SHOWN ON THIS PLAN ARE IN METRES AND CAN BE CONVERTED TO FEET BY DIVIDING BY 0.3048

**SKETCH SHOWING LOCATION OF SANITARY FORCEMAIN
 CHAUDIERE & VICTORIA ISLANDS
 CITY OF OTTAWA**

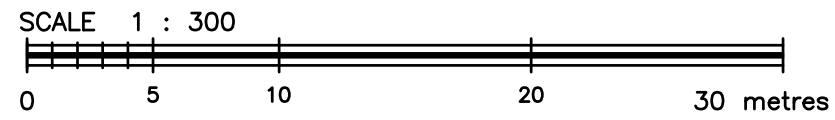

FAIRHALL, MOFFATT & WOODLAND LIMITED
 ONTARIO LAND SURVEYORS

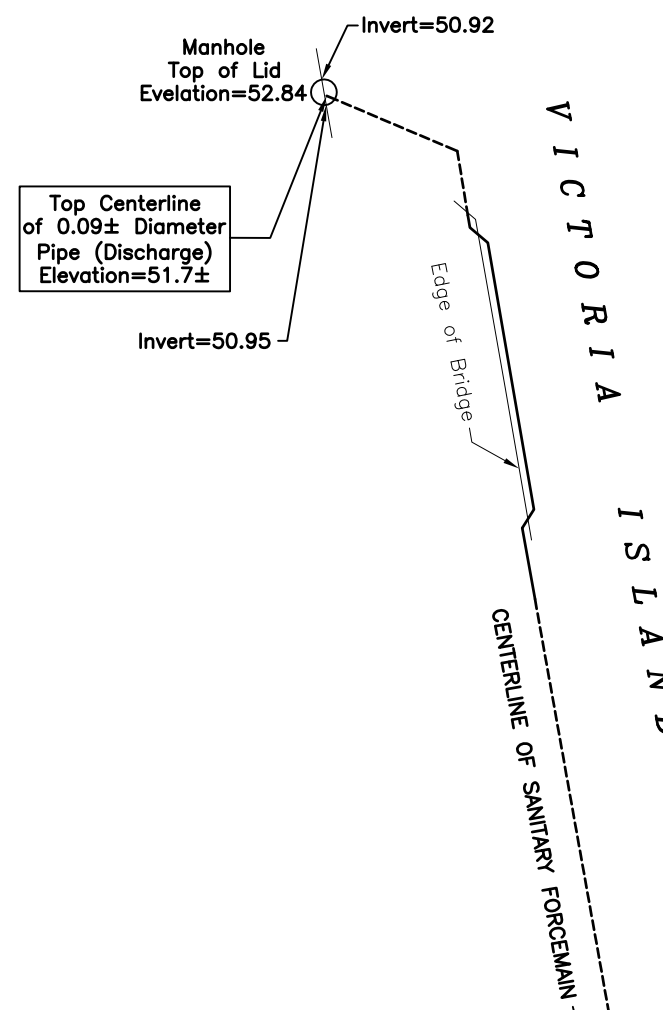
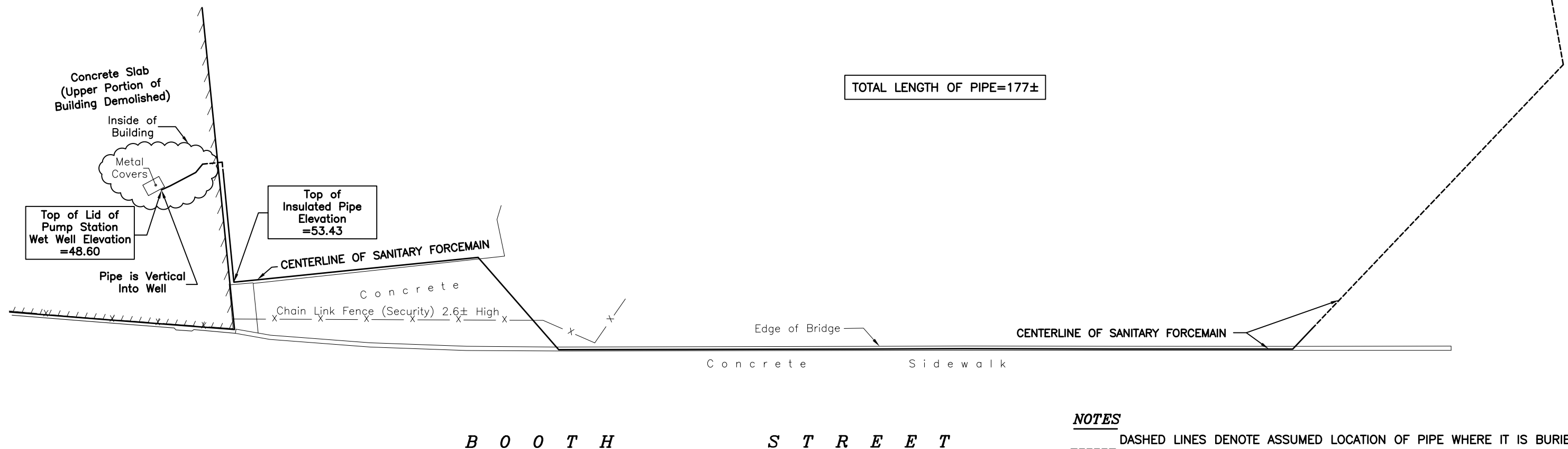
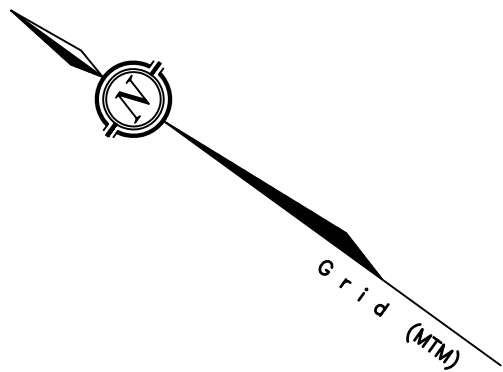

NOTES
 ----- DASHED LINES DENOTE ASSUMED LOCATION OF PIPE WHERE IT IS BURIED,
 OTHERWISE PIPE IS EXPOSED.

B O O T H S T R E E T

© COPYRIGHT 2015. REPRODUCTION, ALTERATION OR DISTRIBUTION OF THIS PLAN WITHOUT THE WRITTEN CONSENT OF FAIRHALL, MOFFATT & WOODLAND LIMITED IS PROHIBITED.

Fairhall Moffatt & Woodland LIMITED ONTARIO LAND SURVEYORS <i>Surveying and Land Information Services</i> 100-600 TERRY FOX DRIVE, KANATA, ONTARIO K2L 4B6 TEL: (613) 591-2580 FAX: (613) 591-1495 www.fmw.on.ca		JOB No. V 1 8 3 0 0
		Date of Survey JULY 21, 2015
S:\JOBS\V18300\DWGS 2015-07-23 sk183v.dwg (kb)		

Windmill Existing Sanitary Pumping Station System Curve with Pump Curve
(FM= 75 mm Nominal)

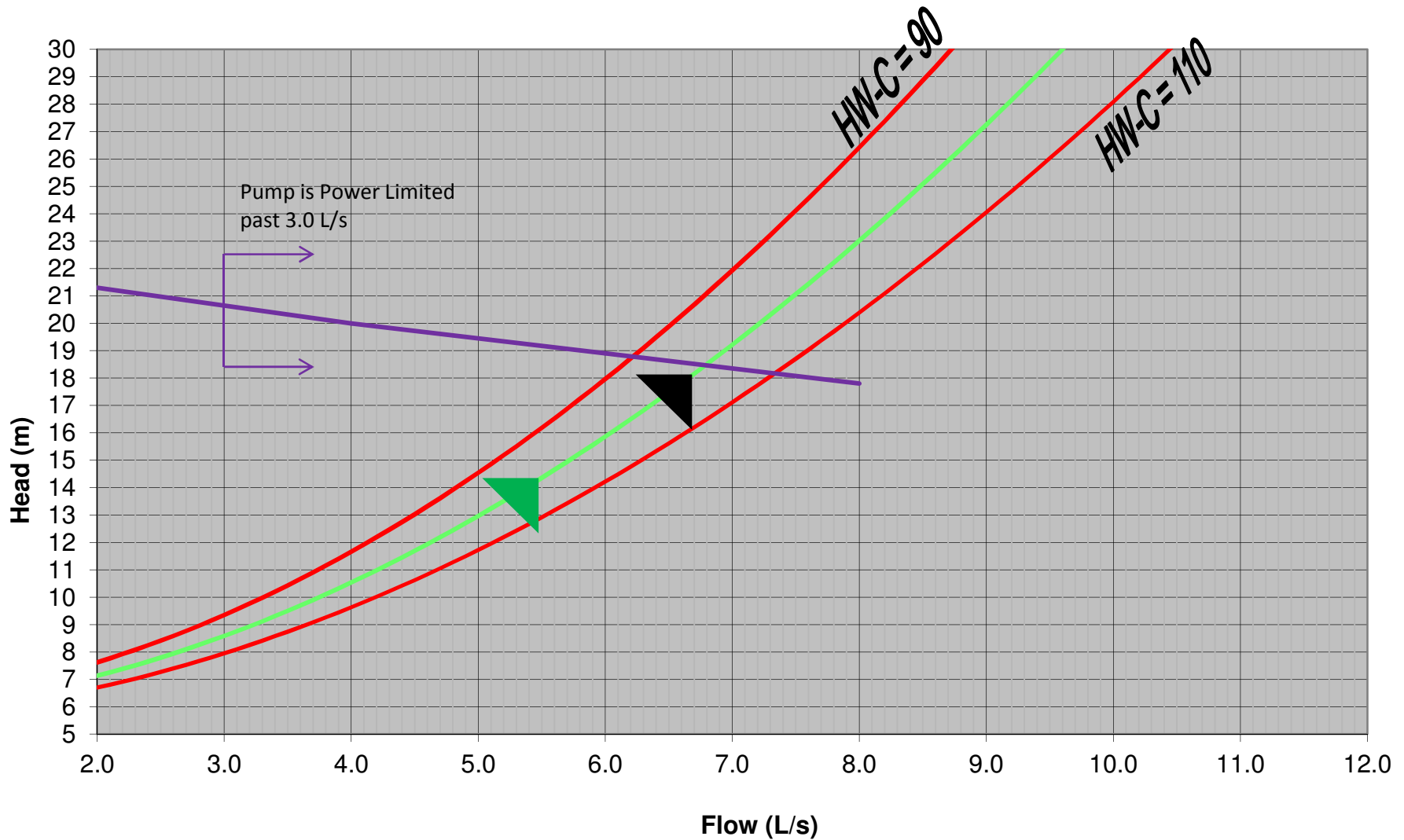



Performance Curve

Product	DP3085.182	Type	HT
Curve No	63-280-00-1570	Issue	3

Date	2015-07-07	Project	
------	------------	---------	--

Power Factor	0.93	1/1-Load	0.91	3/4-Load	0.86	1/2-Load	Rated Power ...	4	hp	(2.98 kW)
Efficiency	80.5 %		82.0 %		81.5 %		Starting ...	23	A	
Motor Data	---		---		---		Rated Current ...	3.8	A	
Comments	IMP DIAM 114 MM	Inlet/Outlet		-		-		Rated Speed ...	3415	rpm
		Imp. Throughlet		52		mm		Tot. Mom. of Inertia ...	0.0030	kgm ²
							No. of Blades	1		

Impeller Diameter			114	mm		
Motor #	15-09-2AL	Stator	51Y	Rev	11	
Freq.	60 Hz	Phases	3	Voltage	600 V	
Poles		2		Ratio		---
Geartype		---		Ratio		---

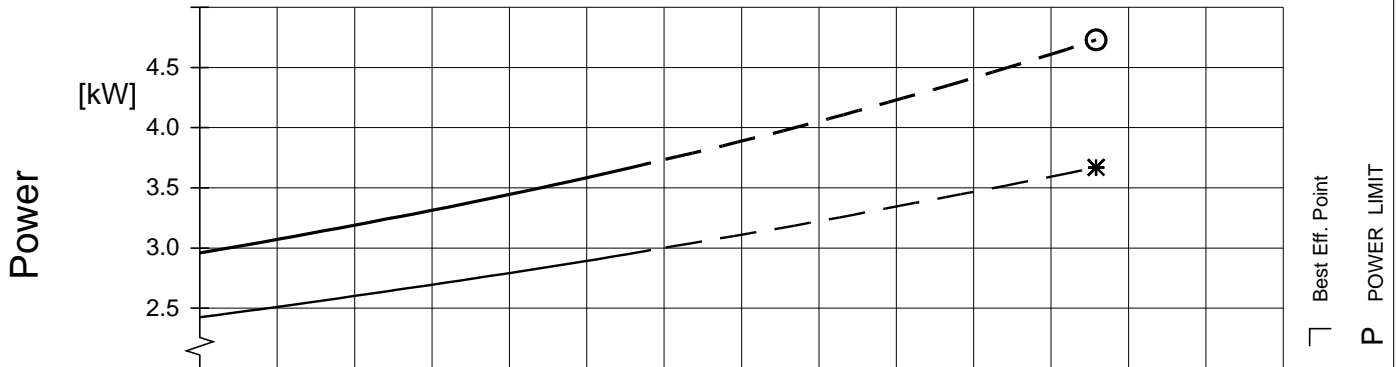

Duty-Point	Flow [l/s]	Head [m]	Power [kW]	Eff. [%]	NPSHR[m]
B.E.P.	5.79	18.9	4.73 (3.67)*	22.7 (29.3)*	5.3

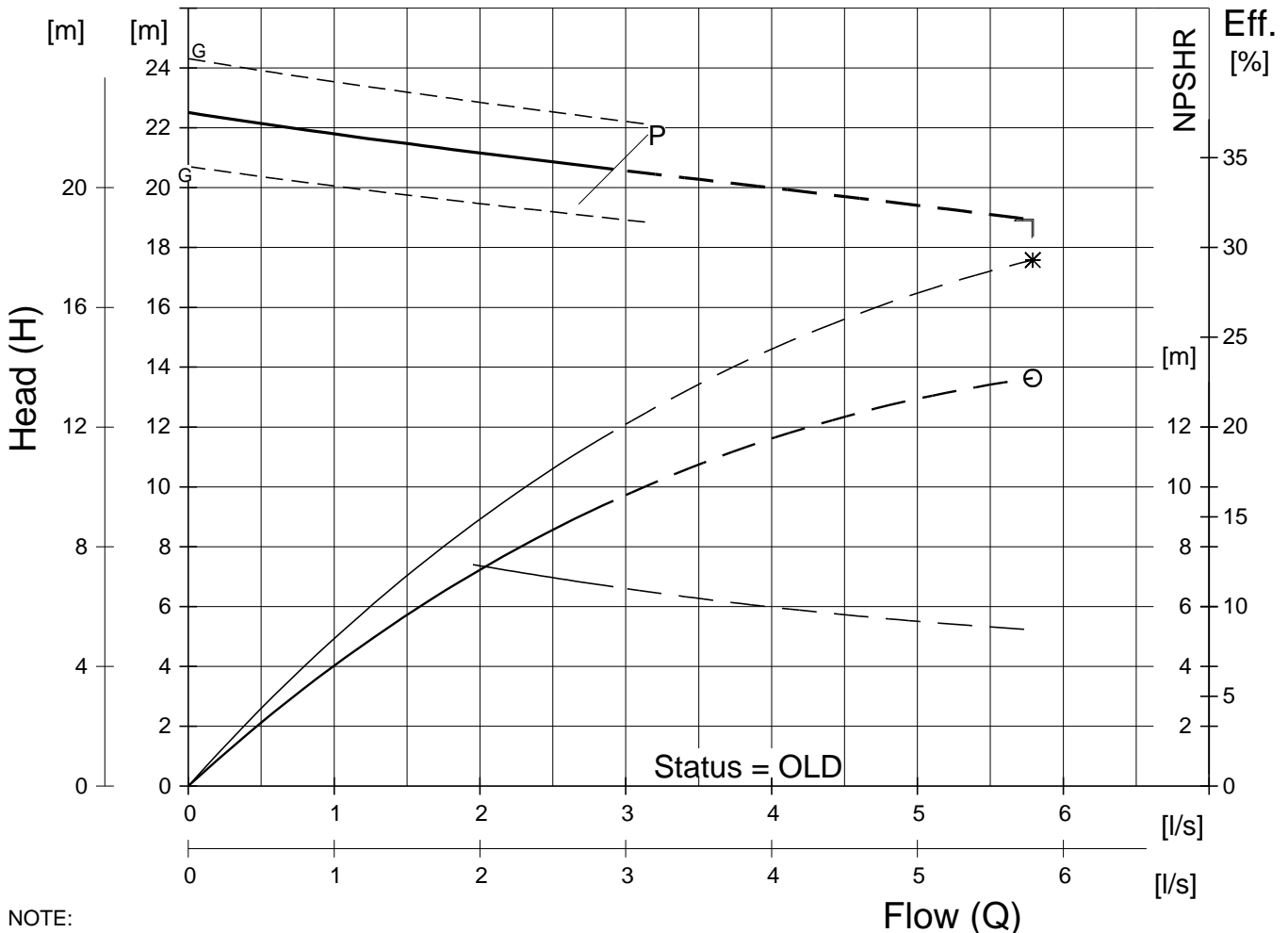

NOTE:
 CURVES SHOW PERFORMANCE WITH CLEAR COLD WATER
 * : Pump EFFICIENCY/Shaft POWER
 O : Overall EFFICIENCY/Input POWER
 NPSHR = NPSH3 + min. operational margin

Guarantee between limits (G) acc. to
 ISO 9906:2012 & ANSI/HI 11.6:2012 / <10kW

APPENDIX D

Stormwater Management

Area ID	Up	Down	Sewer Data															
			Area (ha)	C (-)	Indiv AxC	Acc AxC	T _c (min)	I (mm/hr)	Q (L/s)	DIA (mm)	Slope (%)	Length (m)	A _{hydraulic} (m ²)	R (m)	Velocity (m/s)	Qcap (L/s)	Time Flow (min)	Q / Q full (-)
104B			0.846	0.85	0.72	0.72												
207			0.033	0.90	0.03	0.03												
104A	BLDG	STM104	0.257	0.80	0.21	0.95	10.0	104.2	276.2	525	1.00	48.9	0.216	0.131	1.99	430.1	0.4	0.64
FUT.			0.099	0.90	0.09	0.09												
104C	STM104	STM103	0.032	0.85	0.03	1.07	10.4	102.1	303.6	525	1.50	26.8	0.216	0.131	2.43	526.7	0.2	0.58
	STM103	STM102	0.000	0.00	0.00	1.07	10.6	101.2	300.9	525	1.00	26.7	0.216	0.131	1.99	430.1	0.2	0.70
	STM102	STM101	0.000	0.00	0.00	1.07	10.8	100.1	297.6	600	0.50	7.0	0.283	0.150	1.54	434.2	0.1	0.69
	STM101	HW100	0.000	0.00	0.00	1.07	10.9	99.7	296.5	600	0.50	33.6	0.283	0.150	1.54	434.2	0.4	0.68



Stormceptor Sizing Detailed Report

PCSWMM for Stormceptor

Project Information

Date	27/04/2016
Project Name	Zibi Ontario
Project Number	717
Location	N/A

Stormwater Quality Objective

This report outlines how Stormceptor System can achieve a defined water quality objective through the removal of total suspended solids (TSS). Attached to this report is the Stormceptor Sizing Summary.

Stormceptor System Recommendation

The Stormceptor System model STC 4000 achieves the water quality objective removing 80% TSS for a City of Toronto (clay, silt and sand) particle size distribution.

The Stormceptor System

The Stormceptor oil and sediment separator is sized to treat stormwater runoff by removing pollutants through gravity separation and flotation. Stormceptor's patented design generates positive TSS removal for all rainfall events, including large storms. Significant levels of pollutants such as heavy metals, free oils and nutrients are prevented from entering natural water resources and the re-suspension of previously captured sediment (scour) does not occur.

Stormceptor provides a high level of TSS removal for small frequent storm events that represent the majority of annual rainfall volume and pollutant load. Positive treatment continues for large infrequent events, however, such events have little impact on the average annual TSS removal as they represent a small percentage of the total runoff volume and pollutant load.

Stormceptor is the only oil and sediment separator on the market sized to remove TSS for a wide range of particle sizes, including fine sediments (clays and silts), that are often overlooked in the design of other stormwater treatment devices.

Small storms dominate hydrologic activity, US EPA reports

“Early efforts in stormwater management focused on flood events ranging from the 2-yr to the 100-yr storm. Increasingly stormwater professionals have come to realize that small storms (i.e. < 1 in. rainfall) dominate watershed hydrologic parameters typically associated with water quality management issues and BMP design. These small storms are responsible for most annual urban runoff and groundwater recharge. Likewise, with the exception of eroded sediment, they are responsible for most pollutant washoff from urban surfaces. Therefore, the small storms are of most concern for the stormwater management objectives of ground water recharge, water quality resource protection and thermal impacts control.”

“Most rainfall events are much smaller than design storms used for urban drainage models. In any given area, most frequently recurrent rainfall events are small (less than 1 in. of daily rainfall).”

“Continuous simulation offers possibilities for designing and managing BMPs on an individual site-by-site basis that are not provided by other widely used simpler analysis methods. Therefore its application and use should be encouraged.”

– US EPA Stormwater Best Management Practice Design Guide, Volume 1 – General Considerations, 2004

Design Methodology

Each Stormceptor system is sized using PCSWMM for Stormceptor, a continuous simulation model based on US EPA SWMM. The program calculates hydrology from up-to-date local historical rainfall data and specified site parameters. With US EPA SWMM’s precision, every Stormceptor unit is designed to achieve a defined water quality objective.

The TSS removal data presented follows US EPA guidelines to reduce the average annual TSS load. Stormceptor’s unit process for TSS removal is settling. The settling model calculates TSS removal by analyzing (summary of analysis presented in Appendix 2):

- Site parameters
- Continuous historical rainfall, including duration, distribution, peaks (Figure 1)
- Interevent periods
- Particle size distribution
- Particle settling velocities (Stokes Law, corrected for drag)
- TSS load (Figure 2)
- Detention time of the system

The Stormceptor System maintains continuous positive TSS removal for all influent flow rates. Figure 3 illustrates the continuous treatment by Stormceptor throughout the full range of storm events analyzed. It is clear that large events do not significantly impact the average annual TSS removal. There is no decline in cumulative TSS removal, indicating scour does not occur as the flow rate increases.

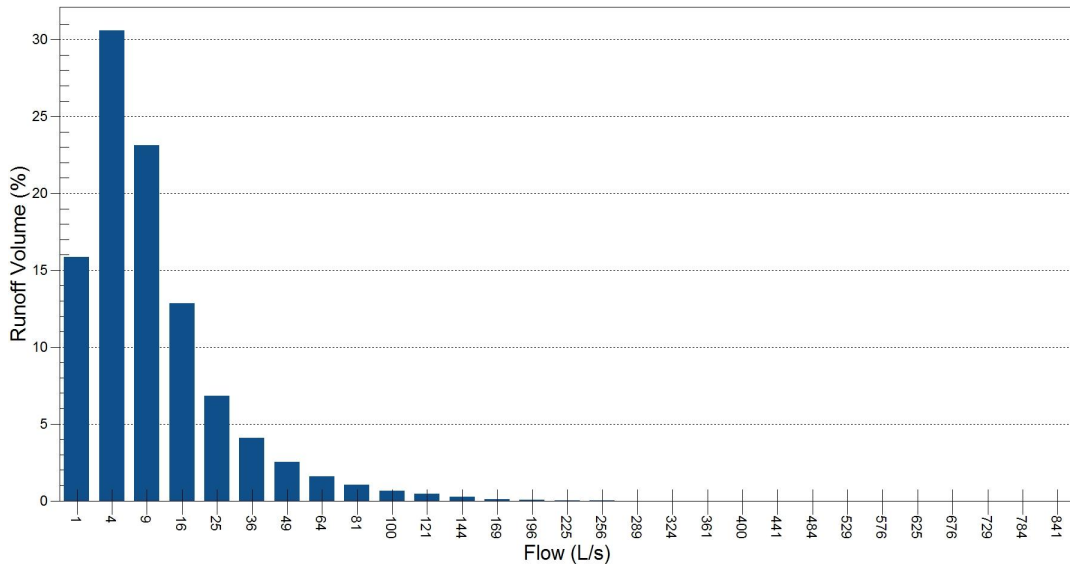

Figure 1. Runoff Volume by Flow Rate for OTTAWA MACDONALD-CARTIER INT'L A – ON 6000, 1967 to 2003 for 1.34 ha, 90% impervious. Small frequent storm events represent the majority of annual rainfall volume. Large infrequent events have little impact on the average annual TSS removal, as they represent a small percentage of the total annual volume of runoff.

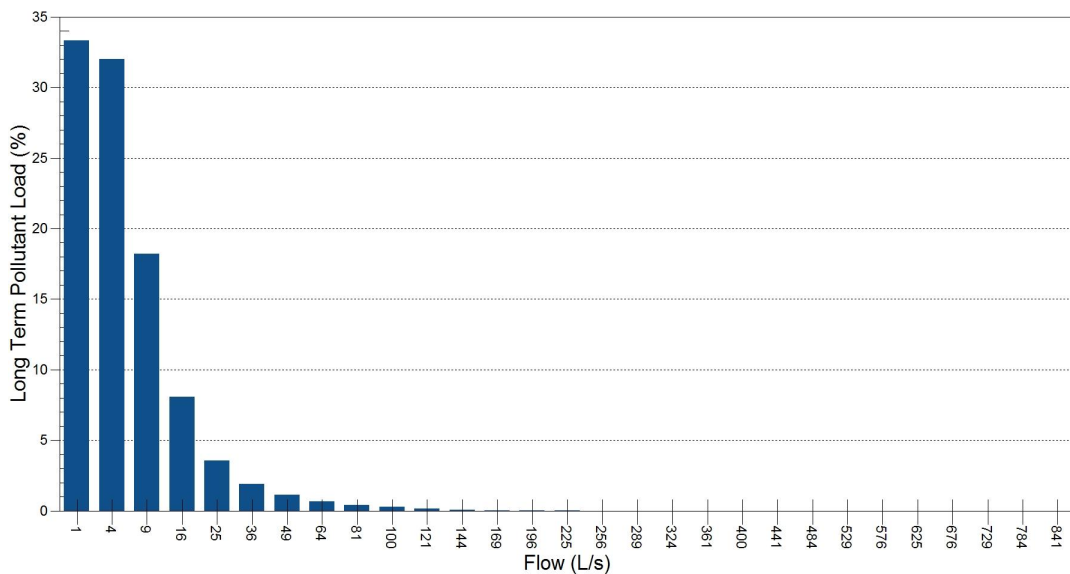
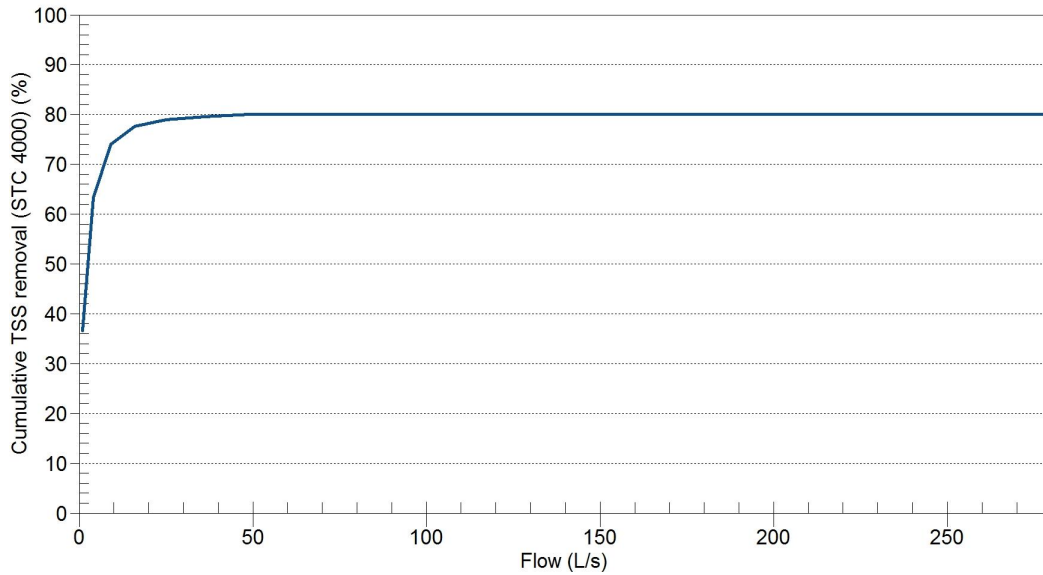

Figure 2. Long Term Pollutant Load by Flow Rate for OTTAWA MACDONALD-CARTIER INT'L A – 6000, 1967 to 2003 for 1.34 ha, 90% impervious. The majority of the annual pollutant load is transported by small frequent storm events. Conversely, large infrequent events carry an insignificant percentage of the total annual pollutant load.



Stormceptor Model	STC 4000	Drainage Area (ha)	1.34
TSS Removal (%)	80	Impervious (%)	90

Figure 3. Cumulative TSS Removal by Flow Rate for OTTAWA MACDONALD-CARTIER INT'L A – 6000, 1967 to 2003. Stormceptor continuously removes TSS throughout the full range of storm events analyzed. Note that large events do not significantly impact the average annual TSS removal. Therefore no decline in cumulative TSS removal indicates scour does not occur as the flow rate increases.



Appendix 1 Stormceptor Design Summary

Project Information

Date	27/04/2016
Project Name	Zibi Ontario
Project Number	717
Location	N/A

Designer Information

Company	N/A
Contact	N/A

Notes

N/A

Drainage Area

Total Area (ha)	1.34
Imperviousness (%)	90

The Stormceptor System model STC 4000 achieves the water quality objective removing 80% TSS for a City of Toronto (clay, silt and sand) particle size distribution.

Rainfall

Name	OTTAWA MACDONALD-CARTIER INT'L A
State	ON
ID	6000
Years of Records	1967 to 2003
Latitude	45°19'N
Longitude	75°40'W

Water Quality Objective

TSS Removal (%)	80
-----------------	----

Upstream Storage

Storage (ha-m)	Discharge (L/s)
0	0

Stormceptor Sizing Summary

Stormceptor Model	TSS Removal
	%
STC 300	58
STC 750	69
STC 1000	69
STC 1500	70
STC 2000	75
STC 3000	76
STC 4000	80
STC 5000	81
STC 6000	83
STC 9000	87
STC 10000	87
STC 14000	89



Particle Size Distribution

Removing silt particles from runoff ensures that the majority of the pollutants, such as hydrocarbons and heavy metals that adhere to fine particles, are not discharged into our natural water courses. The table below lists the particle size distribution used to define the annual TSS removal.

City of Toronto (clay, silt and sand)

Particle Size µm	Distribution %	Specific Gravity	Settling Velocity m/s	Particle Size µm	Distribution %	Specific Gravity	Settling Velocity m/s
10	20	2.65	0.0004				
30	10	2.65	0.0008				
50	10	2.65	0.0022				
95	20	2.65	0.0063				
265	20	2.65	0.0366				
1000	20	2.65	0.1691				

Stormceptor Design Notes

- Stormceptor performance estimates are based on simulations using PCSWMM for Stormceptor version 1.0
- Design estimates listed are only representative of specific project requirements based on total suspended solids (TSS) removal.
- Only the STC 300 is adaptable to function with a catch basin inlet and/or inline pipes.
- Only the Stormceptor models STC 750 to STC 6000 may accommodate multiple inlet pipes.
- Inlet and outlet invert elevation differences are as follows:

Inlet and Outlet Pipe Invert Elevations Differences

Inlet Pipe Configuration	STC 300	STC 750 to STC 6000	STC 9000 to STC 14000
Single inlet pipe	75 mm	25 mm	75 mm
Multiple inlet pipes	75 mm	75 mm	Only one inlet pipe.

- Design estimates are based on stable site conditions only, after construction is completed.
- Design estimates assume that the storm drain is not submerged during zero flows. For submerged applications, please contact your local Stormceptor representative.
- Design estimates may be modified for specific spills controls. Please contact your local Stormceptor representative for further assistance.
- For pricing inquiries or assistance, please contact Imbrium Systems Inc., 1-800-565-4801.

**Appendix 2
Summary of Design Assumptions**

SITE DETAILS

Site Drainage Area

Total Area (ha)	1.34	Imperviousness (%)	90
-----------------	------	--------------------	----

Surface Characteristics

Width (m)	232
Slope (%)	2
Impervious Depression Storage (mm)	0.508
Pervious Depression Storage (mm)	5.08
Impervious Manning's n	0.015
Pervious Manning's n	0.25

Infiltration Parameters

Horton's equation is used to estimate infiltration	
Max. Infiltration Rate (mm/h)	61.98
Min. Infiltration Rate (mm/h)	10.16
Decay Rate (s ⁻¹)	0.00055
Regeneration Rate (s ⁻¹)	0.01

Maintenance Frequency

Sediment build-up reduces the storage volume for sedimentation. Frequency of maintenance is assumed for TSS removal calculations.	
Maintenance Frequency (months)	12

Evaporation

Daily Evaporation Rate (mm/day)	2.54
---------------------------------	------

Dry Weather Flow

Dry Weather Flow (L/s)	No
------------------------	----

Upstream Attenuation

Stage-storage and stage-discharge relationship used to model attenuation upstream of the Stormceptor System is identified in the table below.

Storage ha-m	Discharge L/s
0	0

PARTICLE SIZE DISTRIBUTION

Particle Size Distribution

Removing fine particles from runoff ensures the majority of pollutants, such as heavy metals, hydrocarbons, free oils and nutrients are not discharged into natural water resources. The table below identifies the particle size distribution selected to define TSS removal for the design of the Stormceptor System.

City of Toronto (clay, silt and sand)

Particle Size µm	Distribution %	Specific Gravity	Settling Velocity m/s		Particle Size µm	Distribution %	Specific Gravity	Settling Velocity m/s
10	20	2.65	0.0004					
30	10	2.65	0.0008					
50	10	2.65	0.0022					
95	20	2.65	0.0063					
265	20	2.65	0.0366					
1000	20	2.65	0.1691					

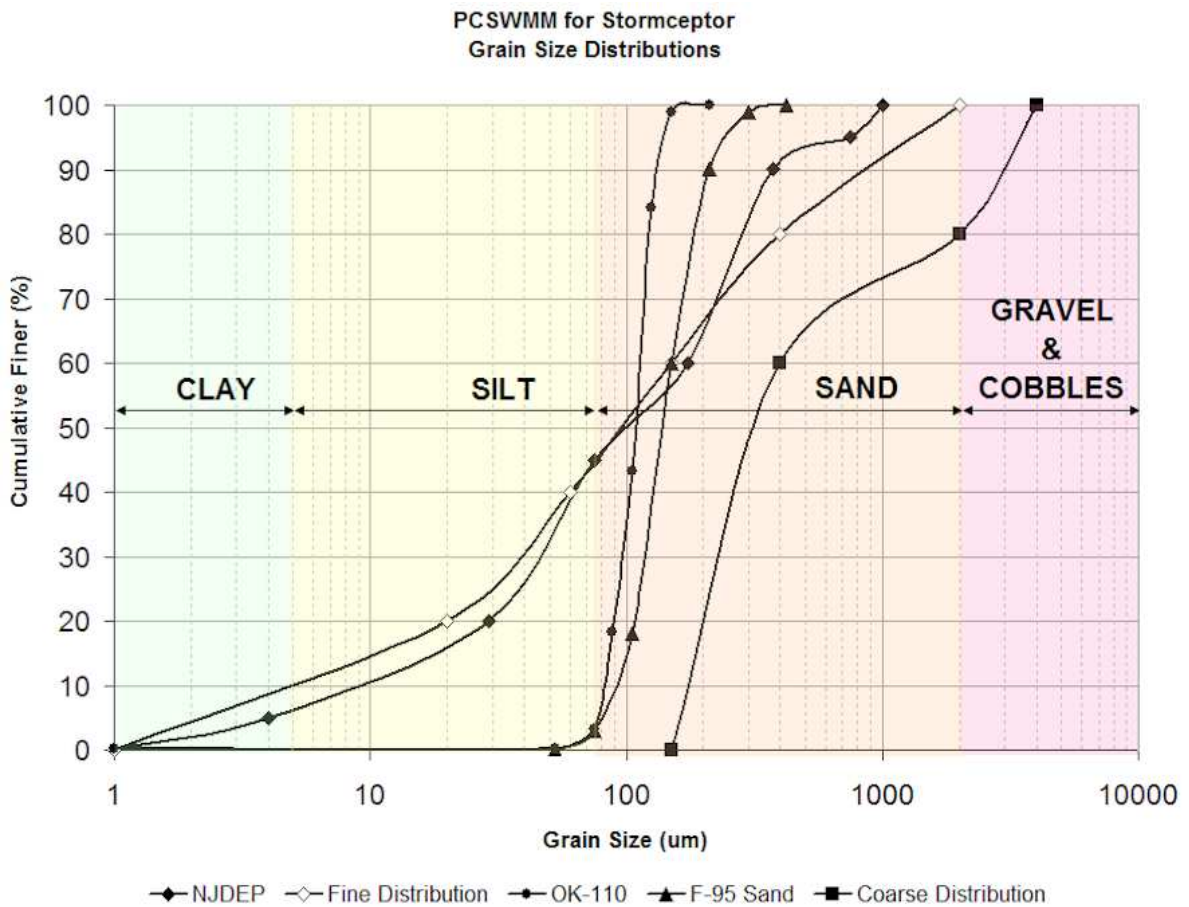

Figure 1. PCSWMM for Stormceptor standard design grain size distributions.



TSS LOADING

TSS Loading Parameters

TSS Loading Function	Buildup / Washoff
----------------------	-------------------

Parameters

Target Event Mean Concentration (EMC) (mg/L)	125
Exponential Buildup Power	0.4
Exponential Washoff Exponential	0.2

HYDROLOGY ANALYSIS

PCSWMM for Stormceptor calculates annual hydrology with the US EPA SWMM and local continuous historical rainfall data. Performance calculations of the Stormceptor System are based on the average annual removal of TSS for the selected site parameters. The Stormceptor System is engineered to capture fine particles (silts and sands) by focusing on average annual runoff volume ensuring positive removal efficiency is maintained during all rainfall events, while preventing the opportunity for negative removal efficiency (scour).

Smaller recurring storms account for the majority of rainfall events and average annual runoff volume, as observed in the historical rainfall data analyses presented in this section.

Rainfall Station

Rainfall Station	OTTAWA MACDONALD-CARTIER INT'L A		
Rainfall File Name	ON6000.NDC	Total Number of Events	4537
Latitude	45°19'N	Total Rainfall (mm)	20978.1
Longitude	75°40'W	Average Annual Rainfall (mm)	567.0
Elevation (m)	371	Total Evaporation (mm)	1821.2
Rainfall Period of Record (y)	37	Total Infiltration (mm)	2089.3
Total Rainfall Period (y)	37	Percentage of Rainfall that is Runoff (%)	81.8

Rainfall Event Analysis

Rainfall Depth mm	No. of Events	Percentage of Total Events %	Total Volume mm	Percentage of Annual Volume %
6.35	3564	78.6	5671	27.0
12.70	508	11.2	4533	21.6
19.05	223	4.9	3434	16.4
25.40	102	2.2	2244	10.7
31.75	60	1.3	1704	8.1
38.10	33	0.7	1145	5.5
44.45	28	0.6	1165	5.6
50.80	9	0.2	416	2.0
57.15	5	0.1	272	1.3
63.50	1	0.0	63	0.3
69.85	1	0.0	64	0.3
76.20	1	0.0	76	0.4
82.55	0	0.0	0	0.0
88.90	1	0.0	84	0.4
95.25	0	0.0	0	0.0
101.60	0	0.0	0	0.0
107.95	0	0.0	0	0.0
114.30	1	0.0	109	0.5
120.65	0	0.0	0	0.0
127.00	0	0.0	0	0.0
133.35	0	0.0	0	0.0
139.70	0	0.0	0	0.0
146.05	0	0.0	0	0.0
152.40	0	0.0	0	0.0
158.75	0	0.0	0	0.0
165.10	0	0.0	0	0.0
171.45	0	0.0	0	0.0
177.80	0	0.0	0	0.0
184.15	0	0.0	0	0.0
190.50	0	0.0	0	0.0
196.85	0	0.0	0	0.0
203.20	0	0.0	0	0.0
209.55	0	0.0	0	0.0
>209.55	0	0.0	0	0.0

Frequency of Occurrence by Rainfall Depths

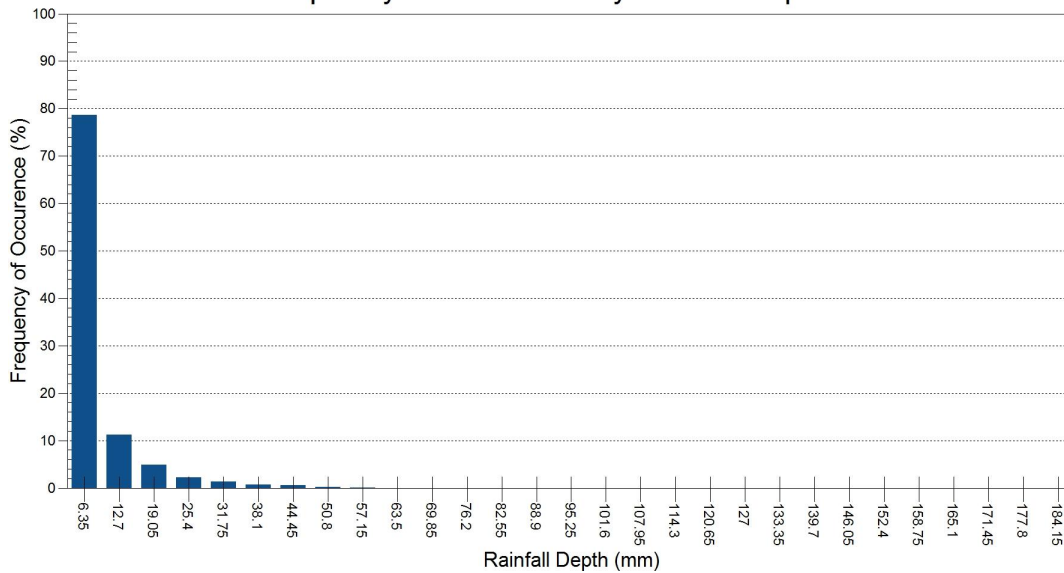

Pollutograph

Flow Rate	Cumulative Mass
L/s	%
1	33.4
4	65.5
9	83.7
16	91.8
25	95.4
36	97.3
49	98.4
64	99.0
81	99.4
100	99.7
121	99.9
144	99.9
169	100.0
196	100.0
225	100.0
256	100.0
289	100.0
324	100.0
361	100.0
400	100.0
441	100.0
484	100.0
529	100.0
576	100.0
625	100.0
676	100.0
729	100.0
784	100.0
841	100.0
900	100.0

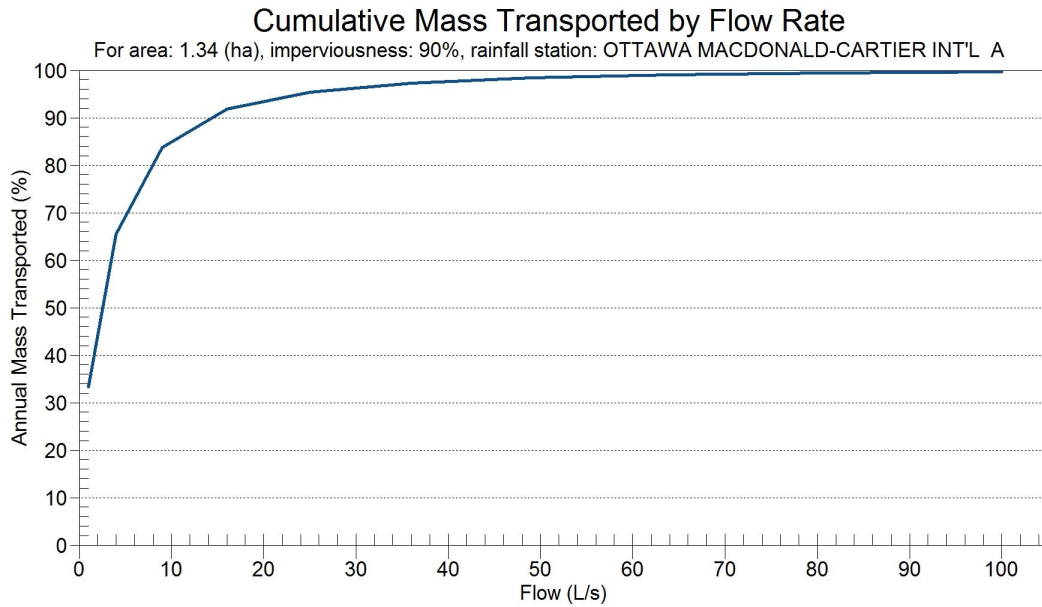

CB Grate CB Lead Capture at Sag

Depth of Flow (m)	Single CB Flow* (L/s)	Twin CB Flow* (L/s)	CB Lead Head (m)	250mm CB Lead Flow (L/s)**		Single CB Discharge (L/s)	Twin CB Discharge (L/s)
0	0	0	1.5	162		0	0
0.01	1	1	1.51	163		1	1
0.02	2	3	1.52	164		2	3
0.03	4	5	1.53	164		4	5
0.04	7	9	1.54	165		7	9
0.05	12	16	1.55	165		12	16
0.06	18	27	1.56	166		18	27
0.07	23	36	1.57	166		23	36
0.08	36	54	1.58	167		36	54
0.09	42	71	1.59	167		42	71
0.1	61	91	1.6	168		61	91
0.11	73	109	1.61	168		73	109
0.12	85	127	1.62	169		85	127
0.13	99	140	1.63	169		99	140
0.14	109	155	1.64	170		109	155
0.15	120	169	1.65	170		120	169
0.16	129	183	1.66	171		129	171
0.17	136	196	1.67	171		136	171
0.18	145	211	1.68	172		145	172
0.19	150	228	1.69	172		150	172
0.2	156	243	1.7	173		156	173
0.21	161	259	1.71	173		161	173
0.22	167	275	1.72	174		167	174
0.23	172	291	1.73	174		172	174
0.24	176	307	1.74	175		175	175
0.25	181	322	1.75	175		175	175
0.26	186	337	1.76	176		176	176
0.27	189	354	1.77	176		176	176
0.28	194	371	1.78	177		177	177
0.29	199	387	1.79	177		177	177
0.3	202	403	1.8	178		178	178

* CB Grate Flow calculated using Table 4.19 of the MTO Drainage Management Manual, 1997

**CB Lead Flow calculated per the orifice equation $Q = C * A * \sqrt{2 * g * H}$

Design Chart 4.19: Inlet Capacity at Road Sag

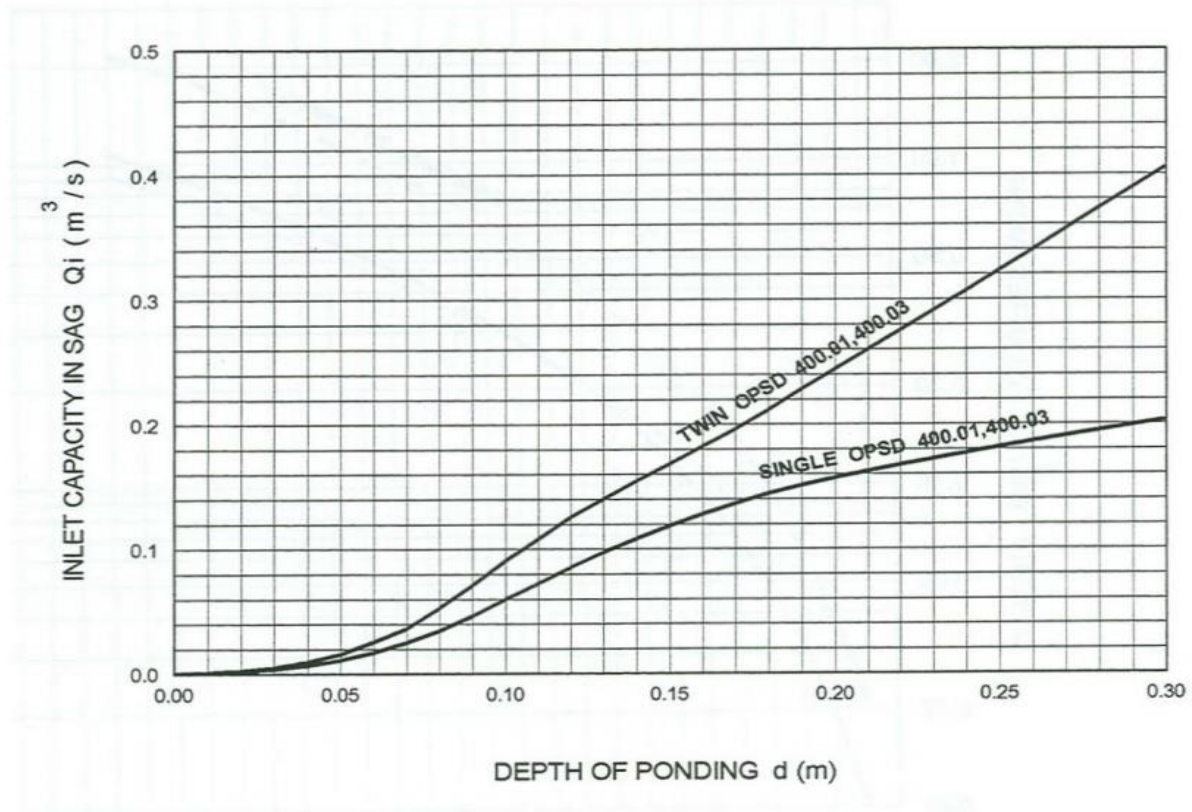

Area 104A Stage-Discharge Curve

Depth (m)	Single CB Discharge (L/s)
0	0
0.01	1
0.02	2
0.03	4
0.04	7
0.05	12
0.06	18
0.07	23
0.08	36
0.09	42
0.1	61
0.11	73
0.12	85
0.13	99
0.14	109
0.15	120
0.16	129
0.17	136
0.18	145
0.19	150
0.2	156
0.21	161
0.22	167
0.23	172
0.24	175
0.25	175
0.26	176
0.27	176
0.28	177
0.29	177
0.3	178

Stage	Depth AD (m)	Flow AD (L/s)	Depth Trench Drain (m)	Trench Drain Flow (L/s)	Total Flow (L/s)
54.72	0	0	0	0	0.0
54.77	0.05	24.0	0	5.9	29.9
54.86	0.14	218.0	0.09	5.9	223.9
54.96	0.24	349.9	0.19	5.9	355.8

Area 104B Stage-Discharge Curve

Depth (m)	Twin CB Discharge (L/s)
0	0
0.01	1
0.02	3
0.03	5
0.04	9
0.05	16
0.06	27
0.07	36
0.08	54
0.09	71
0.1	91
0.11	109
0.12	127
0.13	140
0.14	155
0.15	169
0.16	171
0.17	171
0.18	172
0.19	172
0.2	173
0.21	173
0.22	174
0.23	174
0.24	175
0.25	175
0.26	176
0.27	176
0.28	177
0.29	177
0.3	178

Stage	Depth DCB104D (m)	Flow DCB104D (L/s)
52.74	0	0.0
52.84	0.1	91.0
52.98	0.24	175.0

SlabDrain - H100SK Iron edge rail channel system

Iron Slotted grate

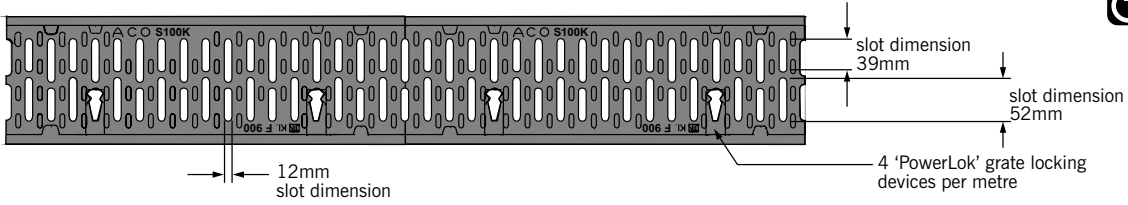

Iron Intercept Heelsafe® Anti-Slip grate

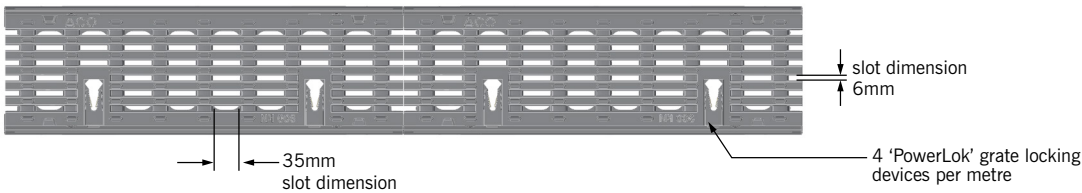

This grate is part of ACO's Heelsafe® Anti-Slip range. For more information visit www.heelsafe.com.au

H100SK channel

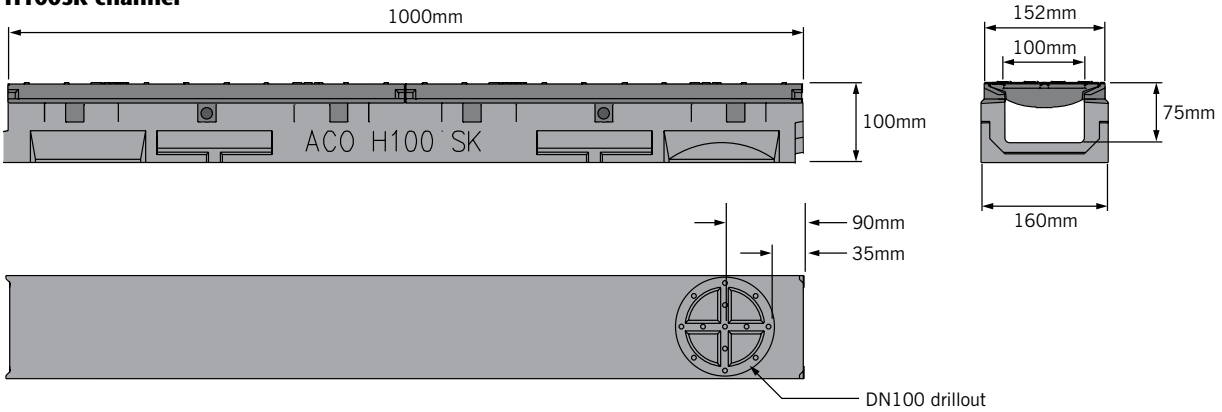

End Cap

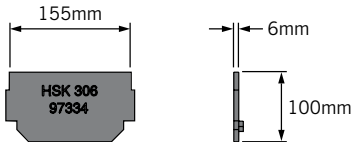

Outlet flow rates

Product	Outlet size	Invert Depth (mm)	L/s
H100SK	100mm round	75	5.9

Note: These are the pipe flow rates at the specified outlet, NOT channel flow rates.

ACO Specification Information



Description	Part No.	Invert ² (mm)	Weight (kg)
H100SK Neutral channel with iron slotted grate - (1m)	141797	75	31.5
H100SK Neutral channel with iron intercept Heelsafe® Anti-Slip grate - (1m)	141798	75	33.9
End cap	97334	100 ³	0.5
Debris strainer for 100mm drillout	93488	-	0.1
Grate removal tool	01318	-	0.1
PowerLok safety clip	10443	-	-

Notes:

1. Channel and grate assembly come complete.
2. To calculate overall channel depth add 25mm to invert depth.
3. Overall depth of end cap.

Specifications			
General The surface drainage system shall be ACO's SlabDrain H100SK polymer concrete shallow channel system with ductile iron edge rails as manufactured by ACO.	Flexural Strength:	26 MPa	for use in areas with depth restrictions. All channels shall be interlocking with a male/female joint.
	Tensile Strength:	14 MPa	
	Water Absorption:	0.07%	
	Frost Proof:	YES	
	Coefficient of Expansion/ Contraction:	2.02x10 ⁻⁵ /°C	
	Water Vapour Transmission:	0.0364g/m ²	
	Non Flammable:	YES	
	Roughness (Mannings):	n=0.011	
	Resistant to Weathering:	YES	
	Dilute Acid and Alkali Resistant:	YES	
Materials H100SK channels shall be manufactured from polyester resin polymer concrete with integrally cast-in ductile iron edge rails. Properties of polymer concrete will be as follows with supporting documentation:	SF Sealant Groove:	YES	Grates <i>Insert specification for the selected grate. Refer to the relevant ACO Specification Information sheet, click: http://www.acodrain.com.au/resources</i>
	Channels H100SK channel shall be 100mm nominal internal width with an overall width of 160mm. Channels shall have an overall depth of 100mm		
	Installation The complete drainage system shall be by ACO and to be installed for its intended purpose. Any deviation or partial use of the specified system and/or improper installation will void all warranties provided by ACO.		
Compressive Strength:	98 MPa		

**ACO Polycrete Pty Ltd
Australia**

Ph: 1300 765 226
www.acodrain.com.au
sales@acoaus.com.au

**ACO Limited
New Zealand**

Ph: 0800 448 080
www.acodrain.co.nz
sales@aconz.co.nz



© February, 2014 ACO Polycrete Pty Ltd. All reasonable care has been taken in compiling the information in this document. All recommendations and suggestions on the use of ACO products are made without guarantee since the conditions of use are beyond the control of the company. It is the customer's responsibility to ensure that each product is fit for its intended purpose and that the actual conditions are suitable. ACO Polycrete Pty Ltd. pursues a policy of continuous product development and reserves the right to amend specifications without notice.

[TITLE]

[OPTIONS]

FLOW_UNITS LPS
INFILTRATION HORTON
FLOW_ROUTING DYNWAVE
START_DATE 01/01/2000
START_TIME 00:01:00
REPORT_START_DATE 01/01/2000
REPORT_START_TIME 00:01:00
END_DATE 01/02/2000
END_TIME 00:00:00
SWEEP_START 01/01
SWEEP_END 12/31
DRY_DAYS 0
REPORT_STEP 00:01:00
WET_STEP 00:01:00
DRY_STEP 00:01:00
ROUTING_STEP 0:00:02
ALLOW_PONDING YES
INERTIAL_DAMPING PARTIAL
VARIABLE_STEP 0.75
LENGTHENING_STEP 0
MIN_SURFAREA 0
NORMAL_FLOW_LIMITED BOTH
SKIP_STEADY_STATE NO
FORCE_MAIN_EQUATION H-W
LINK_OFFSETS ELEVATION
MIN_SLOPE 0

[EVAPORATION]

;;Type Parameters
;;-----
CONSTANT 0.0
DRY_ONLY NO

[RAINGAGES]

;;
;;Name Type Intrl Catch Source
;;-----
1 INTENSITY 0:10 1.0 TIMESERIES CH4H005

[SUBCATCHMENTS]

;;	;;Name	Raingage	Outlet	Total Area	Pcnt. Imperv	Width	Pcnt. Slope	Curb Length	Snow Pack
;;	-----	-----	-----	-----	-----	-----	-----	-----	-----
	104B	1	MJR-105	0.906	93	51	1.5	0	
	104A	1	24	0.234	86	234	2	0	
	FUT	1	MJR-107	0.153	99	38	1.5	0	

```

[SUBAREAS]
;;Subcatchment  N-Imperv  N-Perv  S-Imperv  S-Perv  PctZero  RouteTo  PctRouted
;;-----
104B  0.013  0.25  1.57  4.67  0  OUTLET
104A  0.013  0.25  1.57  4.67  0  OUTLET
FUT   0.013  0.25  1.57  4.67  0  OUTLET

```

```

[INFILTRATION]
;;Subcatchment  MaxRate  MinRate  Decay  DryTime  MaxInfil
;;-----
104B  76.2  13.2  4.14  7  0
104A  76.2  13.2  4.14  7  0
FUT   76.2  13.2  4.14  7  0

```

```

[JUNCTIONS]
;;
;;Name          Invert  Max.  Init.  Surcharge  Poned
                Elev.  Depth Depth  Depth      Area
;;-----
STM104          51.29  2.22  0      0           0
STM103          49.51  2.89  0      0           0
STM102          49.21  2.79  0      0           0
STM101          49.11  3      0      0           0
STM105          51.70  1.97  0      0           0
STM106          51.95  2.1   0      0           0
MJR-107         53.49  0.17  0      0           0
DUMMY           54.35  0.46  0      0           0
MJR-103         51.61  0.16  0      0           0

```

```

[OUTFALLS]
;;
;;Name          Invert  Outfall  Stage/Table  Tide
                Elev.  Type     Time Series  Gate
;;-----
19             49.00  FIXED    48.54        NO
20             53.68  FREE     0            NO
21             50.42  FREE     0            NO

```

```

[STORAGE]
;;
;;Name          Invert  Max.  Init.  Storage  Curve  Poned  Evap.
                Elev.  Depth Depth  Curve   Params Area  Frac.  Infiltration Parameters
;;-----
MJR-105         53.03  0.24  0      TABULAR  CB104D-SAG  0  0
24             54.72  0.24  0      FUNCTIONAL 1000  0  0

```

```

[CONDUITS]
;;
;;Name          Inlet  Outlet  Length  Manning  Inlet  Outlet  Init.  Max.
                Node   Node           N      Offset Offset  Flow  Flow
;;-----
26             STM106  STM105  21.6   0.013   51.95  51.73  0      0
27             STM105  STM104  10.5   0.013   51.70  51.58  0      0
30             STM103  STM102  29.1   0.013   49.51  49.24  0      0

```

31	STM102	STM101	13.6	0.013	49.21	49.14	0	0
32	STM101	19	21.3	0.013	49.11	49	0	0
MJR-PERLY-2	MJR-105	MJR-103	85	0.013	53.13	51.61	0	0
MJR-PERLY-1	MJR-107	MJR-105	10	0.013	53.52	53.13	0	0
34	24	DUMMY	9	0.013	54.80	54.35	0	0
35	DUMMY	20	10	0.013	54.35	53.68	0	0
MJR-BOOTH	MJR-103	21	55	0.013	51.61	50.42	0	0
38	STM104	STM103	99.6	0.013	51.289	49.795	0	0

[ORIFICES]

;;Name	Inlet Node	Outlet Node	Orifice Type	Crest Height	Disch. Coeff.	Flap Gate	Open/Close Time
1	MJR-105	STM104	BOTTOM	53.10	0.61	NO	0
36	MJR-107	STM106	BOTTOM	*	0.61	NO	0

[OUTLETS]

;;Name	Inlet Node	Outlet Node	Outflow Height	Outlet Type	Qcoeff/QTable	Qexpon	Flap Gate
3	MJR-105	STM104	*	TABULAR/DEPTH	104B-SAG		NO
2	24	DUMMY	*	TABULAR/DEPTH	104A-SAG		NO

[XSECTIONS]

;;Link	Shape	Geom1	Geom2	Geom3	Geom4	Barrels
26	CIRCULAR	0.45	0	0	0	1
27	CIRCULAR	0.450	0	0	0	1
30	CIRCULAR	0.525	0	0	0	1
31	CIRCULAR	0.600	0	0	0	1
32	CIRCULAR	0.60	0	0	0	1
MJR-PERLY-2	IRREGULAR	PerleySt-1	0	0	0	1
MJR-PERLY-1	IRREGULAR	PerleySt-1	0	0	0	1
34	IRREGULAR	104A-Major	0	0	0	1
35	RECT_OPEN	0.3	10	0	0	1
MJR-BOOTH	IRREGULAR	BoothSt	0	0	0	1
38	CIRCULAR	0.450	0	0	0	1
1	RECT_CLOSED	0.87	0.87	0	0	
36	RECT_CLOSED	0.75	0.75	0	0	

[TRANSECTS]

;13m										
NC	0	0	0.013							
X1	sect	4		0	0	0.0	0.0	0	0	0
GR	100.155	-6.5	100.085	-3.0	100	-0.15	100	0		
NC	0.013	0.013	0.013							
X1	104A-Major	4	0.0	0.0	0.0	0.0	0.0	0.0	0.0	0.0
GR	54.66	0	54.20	0.9	54.25	5	54.41	9.1		

```

NC 0.013 0.013 0.013
X1 BoothSt 5 0.0 0.0 0.0 0.0 0.0 0.0
GR 51.05 0 50.95 0 51.11 6 50.95 12 51.05 12

```

```

NC 0.013 0.013 0.013
X1 PerleySt-1 5 0.0 0.0 0.0 0.0 0.0 0.0
GR 53.27 0 53.22 0 53.13 3 53.22 6 53.27 6

```

```

[LOSSES]
;;Link      Inlet      Outlet      Average      Flap Gate
;;-----
26          0.5          0.02        0             NO
27          0.5          0.38        0             NO
30          0.5          0.38        0             NO
31          0.5          1.3         0             NO
32          0.5          0.02        0             NO
38          0.5          0.38        0             NO

```

```

[CURVES]
;;Name      Type      X-Value      Y-Value
;;-----
104B-SAG    Rating    0             0
104B-SAG    Rating    0.10          91
104B-SAG    Rating    0.24          175

104A-SAG    Rating    0             0
104A-SAG    Rating    0.05          29.9
104A-SAG    Rating    0.14          223.9
104A-SAG    Rating    0.24          355.8

CB104D-SAG  Storage   0             0
CB104D-SAG  Storage   0.10          105
CB104D-SAG  Storage   0.24          105

CB104A-SAG  Storage   0             0
CB104A-SAG  Storage   0.14          157
CB104A-SAG  Storage   0.24          157

100-YEAR    Tidal     0             94.81
100-YEAR    Tidal     6             94.81
100-YEAR    Tidal     12            0
100-YEAR    Tidal     24            0

```

```

[TIMESERIES]
;;Name      Date      Time      Value
;;-----
;2yr12hrS
2yr12hrS    FILE "P:\General Administrative\5 - DSEL Templates\Site Plan\EPASWMM Template\rainfall\2yr12hrS.dat"

```

```

;5yr12hrS
5yr12hrS      FILE "P:\General Administrative\5 - DSEL Templates\Site Plan\EPASWMM Template\rainfall\5yr12hrS.dat"

;10yr12hrS
10yr12hrS     FILE "P:\General Administrative\5 - DSEL Templates\Site Plan\EPASWMM Template\rainfall\10yr12hrS.dat"

;25yr12hrS
25yr12hrS     FILE "P:\General Administrative\5 - DSEL Templates\Site Plan\EPASWMM Template\rainfall\25yr12hrS.dat"

;50yr12hrS
50yr12hrS     FILE "P:\General Administrative\5 - DSEL Templates\Site Plan\EPASWMM Template\rainfall\50yr12hrS.dat"

;100yr12hrS
100yr12hrS    FILE "P:\General Administrative\5 - DSEL Templates\Site Plan\EPASWMM Template\rainfall\100yr12hrS.dat"

CH4H005       FILE "P:\General Administrative\5 - DSEL Templates\Site Plan\EPASWMM Template\rainfall\CH4H005.dat"

;100-year Storm, 4 Hour Chicago Distribution
CH4H100       FILE "P:\General Administrative\5 - DSEL Templates\Site Plan\EPASWMM Template\rainfall\CH4H100.dat"

CH6H100       FILE "P:\General Administrative\5 - DSEL Templates\Site Plan\EPASWMM Template\rainfall\CH6H100.dat"

CH3H100       FILE "P:\General Administrative\5 - DSEL Templates\Site Plan\EPASWMM Template\rainfall\CH3H100.dat"

;3 hour chicago storm + 20%
CH3H100x     FILE "P:\General Administrative\5 - DSEL Templates\Site Plan\EPASWMM Template\rainfall\CH3H100x.dat"

CH4H002       FILE "P:\General Administrative\5 - DSEL Templates\Site Plan\EPASWMM Template\rainfall\CH4H002.dat"

```

```

[REPORT]
INPUT      NO
CONTROLS   NO
SUBCATCHMENTS ALL
NODES      ALL
LINKS      ALL

```

[TAGS]

```

[MAP]
DIMENSIONS -2500.000 0.000 12500.000 10000.000
Units      None

```

```

[COORDINATES]
;;Node      X-Coord      Y-Coord
;-----
STM104      3232.323      6911.977
STM103      8831.169      6940.837
STM102      10404.040     7460.317
STM101      11168.831     7460.317
STM105      2762.391      6559.767

```

STM106	1756.560	5830.904
MJR-107	2150.146	5495.627
DUMMY	9599.125	1807.580
MJR-103	8845.599	6392.496
19	11581.633	8556.851
20	10144.175	1557.093
21	9424.198	9766.764
MJR-105	3491.254	6370.262
24	4526.239	4271.137

[VERTICES]

;;Link	X-Coord	Y-Coord
;;-----	-----	-----
MJR-PERLY-2	6275.510	6384.840
MJR-PERLY-1	3214.286	5816.327
34	7383.382	3615.160
MJR-BOOTH	10080.175	8862.974
MJR-BOOTH	9395.044	9839.650
3	3622.449	6749.271

[Polygons]

;;Subcatchment	X-Coord	Y-Coord
;;-----	-----	-----
104B	5056.665	5128.005
104B	4652.624	5633.056
104B	4263.014	5113.575
104A	3437.804	3568.999
104A	3437.804	3568.999
104A	3452.381	3568.999
104A	4312.439	3539.845
104A	3787.658	4195.821
104A	3394.072	3510.690
FUT	1552.478	4096.210
FUT	1188.047	5102.041
FUT	532.070	4023.324

[SYMBOLS]

;;Gage	X-Coord	Y-Coord
;;-----	-----	-----
1	-777.143	7405.714

[BACKDROP]

FILE "Z:\Projects\14-717_windmill-the_isles\B_Design\B1_Analysis\B1-4_SWM\2018-06-12_overland-flow\2018-06-11_717_ph1_spa_bnc-SWM-1bmp_Page1.bmp

DIMENSIONS -2500.000 0.000 12500.000 10000.000

EPA STORM WATER MANAGEMENT MODEL - VERSION 5.1 (Build 5.1.012)

WARNING 03: negative offset ignored for Link 38
 WARNING 02: maximum depth increased for Node MJR-107

 NOTE: The summary statistics displayed in this report are based on results found at every computational time step, not just on results from each reporting time step.

 Analysis Options

Flow Units LPS
 Process Models:
 Rainfall/Runoff YES
 RDII NO
 Snowmelt NO
 Groundwater NO
 Flow Routing YES
 Ponding Allowed YES
 Water Quality NO
 Infiltration Method HORTON
 Flow Routing Method DYNWAVE
 Starting Date 01/01/2000 00:01:00
 Ending Date 01/02/2000 00:00:00
 Antecedent Dry Days 0.0
 Report Time Step 00:01:00
 Wet Time Step 00:01:00
 Dry Time Step 00:01:00
 Routing Time Step 2.00 sec
 Variable Time Step YES
 Maximum Trials 8
 Number of Threads 1
 Head Tolerance 0.001524 m

	Volume	Depth
Runoff Quantity Continuity	hectare-m	mm
*****	-----	-----
Total Precipitation	0.044	33.856
Evaporation Loss	0.000	0.000
Infiltration Loss	0.003	2.542
Surface Runoff	0.039	29.875
Final Storage	0.002	1.456
Continuity Error (%)	-0.050	

	Volume	Volume
Flow Routing Continuity	hectare-m	10^6 ltr
*****	-----	-----
Dry Weather Inflow	0.000	0.000
Wet Weather Inflow	0.039	0.386
Groundwater Inflow	0.000	0.000
RDII Inflow	0.000	0.000
External Inflow	0.000	0.000
External Outflow	0.039	0.386
Flooding Loss	0.000	0.000
Evaporation Loss	0.000	0.000
Exfiltration Loss	0.000	0.000
Initial Stored Volume	0.000	0.000
Final Stored Volume	0.000	0.000
Continuity Error (%)	-0.024	

 Highest Continuity Errors

 Node MJR-103 (24.48%)

 Time-Step Critical Elements

None

 Highest Flow Instability Indexes

 All links are stable.

 Routing Time Step Summary

 Minimum Time Step : 0.50 sec
 Average Time Step : 2.00 sec
 Maximum Time Step : 2.00 sec
 Percent in Steady State : 0.00
 Average Iterations per Step : 2.00
 Percent Not Converging : 0.00

 Subcatchment Runoff Summary

Subcatchment	Total Precip mm	Total Runon mm	Total Evap mm	Total Infil mm	Total Runoff mm	Total Runoff 10 ⁶ ltr	Peak Runoff LPS	Runoff Coeff
104B	33.86	0.00	0.00	2.36	30.04	0.27	158.90	0.887
104A	33.86	0.00	0.00	4.68	27.87	0.07	44.08	0.823
FUT	33.86	0.00	0.00	0.33	31.99	0.05	32.30	0.945

 Node Depth Summary

Node	Type	Average Depth Meters	Maximum Depth Meters	Maximum HGL Meters	Time of Max Occurrence days hr:min	Reported Max Depth Meters
STM104	JUNCTION	0.01	0.24	51.53	0 01:19	0.24
STM103	JUNCTION	0.01	0.29	49.80	0 01:19	0.28
STM102	JUNCTION	0.02	0.39	49.60	0 01:20	0.39
STM101	JUNCTION	0.02	0.29	49.40	0 01:20	0.29
STM105	JUNCTION	0.01	0.11	51.81	0 01:19	0.11
STM106	JUNCTION	0.01	0.11	52.06	0 01:19	0.11
MJR-107	JUNCTION	0.00	0.03	53.52	0 01:19	0.03
DUMMY	JUNCTION	0.00	0.00	54.35	0 01:21	0.00
MJR-103	JUNCTION	0.00	0.01	51.62	0 01:20	0.01
19	OUTFALL	0.01	0.27	49.27	0 01:20	0.27
20	OUTFALL	0.00	0.00	53.68	0 01:21	0.00
21	OUTFALL	0.00	0.01	50.43	0 01:20	0.01
MJR-105	STORAGE	0.00	0.11	53.14	0 01:19	0.11
24	STORAGE	0.00	0.03	54.75	0 01:21	0.03

 Node Inflow Summary

Node	Type	Maximum Lateral Inflow LPS	Maximum Total Inflow LPS	Time of Max Occurrence days hr:min	Lateral Inflow Volume 10 ⁶ ltr	Total Inflow Volume 10 ⁶ ltr	Flow Balance Error Percent
STM104	JUNCTION	0.00	185.81	0 01:19	0	0.321	0.007
STM103	JUNCTION	0.00	184.06	0 01:19	0	0.321	0.011
STM102	JUNCTION	0.00	184.15	0 01:19	0	0.321	-0.038
STM101	JUNCTION	0.00	183.38	0 01:20	0	0.321	-0.001
STM105	JUNCTION	0.00	32.22	0 01:19	0	0.0489	0.001
STM106	JUNCTION	0.00	32.25	0 01:19	0	0.0489	-0.001
MJR-107	JUNCTION	32.30	32.30	0 01:19	0.0489	0.0489	-0.003
DUMMY	JUNCTION	0.00	15.79	0 01:21	0	0.0652	0.006

2YR.rpt

MJR-103	JUNCTION	0.00	1.15	0	01:19	0	0.00016	32.407
19	OUTFALL	0.00	183.51	0	01:20	0	0.321	0.000
20	OUTFALL	0.00	15.79	0	01:21	0	0.0652	0.000
21	OUTFALL	0.00	0.28	0	01:20	0	0.000121	0.000
MJR-105	STORAGE	158.90	158.94	0	01:19	0.272	0.272	-0.023
24	STORAGE	44.08	44.08	0	01:19	0.0652	0.0652	-0.002

Node Surcharge Summary

No nodes were surcharged.

Node Flooding Summary

No nodes were flooded.

Storage Volume Summary

Storage Unit	Average Volume 1000 m3	Avg Pcnt Full	Evap Pcnt Loss	Exfil Pcnt Loss	Maximum Volume 1000 m3	Max Pcnt Full	Time of Max Occurrence days hr:min	Maximum Outflow LPS
MJR-105	0.000	0	0	0	0.007	33	0 01:19	154.76
24	0.001	1	0	0	0.026	11	0 01:21	15.79

Outfall Loading Summary

Outfall Node	Flow Freq Pcnt	Avg Flow LPS	Max Flow LPS	Total Volume 10^6 ltr
19	35.38	10.50	183.51	0.321
20	21.78	3.46	15.79	0.065
21	0.94	0.11	0.28	0.000
System	19.37	14.07	199.48	0.386

Link Flow Summary

Link	Type	Maximum Flow LPS	Time of Max Occurrence days hr:min	Maximum Veloc m/sec	Max/ Full Flow	Max/ Full Depth
26	CONDUIT	32.22	0 01:19	1.16	0.11	0.23
27	CONDUIT	32.20	0 01:19	1.14	0.11	0.23
30	CONDUIT	184.15	0 01:19	1.32	0.44	0.62
31	CONDUIT	183.38	0 01:20	1.15	0.42	0.55
32	CONDUIT	183.51	0 01:20	1.40	0.42	0.47
MJR-PERLY-2	CHANNEL	1.15	0 01:19	0.52	0.00	0.06
MJR-PERLY-1	CHANNEL	0.04	0 01:19	0.07	0.00	0.05
34	CHANNEL	0.00	0 00:00	0.00	0.00	0.00
35	CONDUIT	15.79	0 01:21	0.46	0.00	0.01
MJR-BOOTH	CHANNEL	0.28	0 01:20	0.23	0.00	0.04
38	CONDUIT	184.06	0 01:19	2.16	0.53	0.53
1	ORIFICE	55.30	0 01:19			
36	ORIFICE	32.25	0 01:19			
3	DUMMY	98.31	0 01:19			
2	DUMMY	15.79	0 01:21			

 Flow Classification Summary

Conduit	Adjusted /Actual Length	Fraction of Time in Flow Class								
		Dry	Up Dry	Down Dry	Sub Crit	Sup Crit	Up Crit	Down Crit	Norm Ltd	Inlet Ctrl
26	1.00	0.03	0.00	0.00	0.00	0.00	0.00	0.97	0.00	0.00
27	1.00	0.03	0.00	0.00	0.00	0.00	0.00	0.97	0.00	0.00
30	1.00	0.03	0.00	0.00	0.01	0.02	0.00	0.94	0.00	0.00
31	1.00	0.03	0.00	0.00	0.00	0.00	0.00	0.97	0.00	0.00
32	1.00	0.03	0.00	0.00	0.80	0.17	0.00	0.00	0.00	0.00
MJR-PERLY-2	1.00	0.05	0.94	0.00	0.00	0.00	0.00	0.00	0.94	0.00
MJR-PERLY-1	1.00	0.99	0.00	0.00	0.00	0.00	0.00	0.00	0.95	0.00
34	1.00	0.77	0.23	0.00	0.00	0.00	0.00	0.00	0.00	0.00
35	1.00	0.77	0.01	0.00	0.00	0.23	0.00	0.00	0.01	0.00
MJR-BOOTH	1.00	0.05	0.00	0.00	0.81	0.14	0.00	0.00	0.89	0.00
38	1.00	0.02	0.00	0.00	0.00	0.00	0.00	0.98	0.00	0.00

 Conduit Surcharge Summary

No conduits were surcharged.

Analysis begun on: Fri Jun 29 11:43:19 2018
 Analysis ended on: Fri Jun 29 11:43:20 2018
 Total elapsed time: 00:00:01

EPA STORM WATER MANAGEMENT MODEL - VERSION 5.1 (Build 5.1.012)

WARNING 03: negative offset ignored for Link 38
 WARNING 02: maximum depth increased for Node MJR-107

 NOTE: The summary statistics displayed in this report are based on results found at every computational time step, not just on results from each reporting time step.

 Analysis Options

Flow Units LPS
 Process Models:
 Rainfall/Runoff YES
 RDII NO
 Snowmelt NO
 Groundwater NO
 Flow Routing YES
 Ponding Allowed YES
 Water Quality NO
 Infiltration Method HORTON
 Flow Routing Method DYNWAVE
 Starting Date 01/01/2000 00:01:00
 Ending Date 01/02/2000 00:00:00
 Antecedent Dry Days 0.0
 Report Time Step 00:01:00
 Wet Time Step 00:01:00
 Dry Time Step 00:01:00
 Routing Time Step 2.00 sec
 Variable Time Step YES
 Maximum Trials 8
 Number of Threads 1
 Head Tolerance 0.001524 m

	Volume	Depth
Runoff Quantity Continuity	hectare-m	mm
*****	-----	-----
Total Precipitation	0.058	45.120
Evaporation Loss	0.000	0.000
Infiltration Loss	0.004	2.960
Surface Runoff	0.053	40.731
Final Storage	0.002	1.456
Continuity Error (%)	-0.058	

	Volume	Volume
Flow Routing Continuity	hectare-m	10^6 ltr
*****	-----	-----
Dry Weather Inflow	0.000	0.000
Wet Weather Inflow	0.053	0.527
Groundwater Inflow	0.000	0.000
RDII Inflow	0.000	0.000
External Inflow	0.000	0.000
External Outflow	0.053	0.527
Flooding Loss	0.000	0.000
Evaporation Loss	0.000	0.000
Exfiltration Loss	0.000	0.000
Initial Stored Volume	0.000	0.000
Final Stored Volume	0.000	0.000
Continuity Error (%)	-0.030	

 Highest Continuity Errors

 Node MJR-103 (6.23%)

 Time-Step Critical Elements

None

 Highest Flow Instability Indexes

 All links are stable.

 Routing Time Step Summary

 Minimum Time Step : 0.50 sec
 Average Time Step : 2.00 sec
 Maximum Time Step : 2.00 sec
 Percent in Steady State : 0.00
 Average Iterations per Step : 2.00
 Percent Not Converging : 0.00

 Subcatchment Runoff Summary

Subcatchment	Total Precip mm	Total Runon mm	Total Evap mm	Total Infil mm	Total Runoff mm	Total Runoff 10 ⁶ ltr	Peak Runoff LPS	Runoff Coeff
104B	45.12	0.00	0.00	2.78	40.89	0.37	227.46	0.906
104A	45.12	0.00	0.00	5.34	38.50	0.09	64.55	0.853
FUT	45.12	0.00	0.00	0.38	43.22	0.07	44.06	0.958

 Node Depth Summary

Node	Type	Average Depth Meters	Maximum Depth Meters	Maximum HGL Meters	Time of Max Occurrence days hr:min	Reported Max Depth Meters
STM104	JUNCTION	0.01	0.30	51.59	0 01:19	0.30
STM103	JUNCTION	0.02	0.36	49.87	0 01:19	0.36
STM102	JUNCTION	0.02	0.48	49.69	0 01:19	0.48
STM101	JUNCTION	0.02	0.36	49.47	0 01:20	0.36
STM105	JUNCTION	0.01	0.13	51.83	0 01:19	0.13
STM106	JUNCTION	0.01	0.12	52.07	0 01:19	0.12
MJR-107	JUNCTION	0.00	0.04	53.53	0 01:19	0.04
DUMMY	JUNCTION	0.00	0.00	54.35	0 01:21	0.00
MJR-103	JUNCTION	0.00	0.03	51.64	0 01:20	0.03
19	OUTFALL	0.02	0.32	49.32	0 01:20	0.32
20	OUTFALL	0.00	0.00	53.68	0 01:21	0.00
21	OUTFALL	0.00	0.03	50.45	0 01:20	0.03
MJR-105	STORAGE	0.00	0.13	53.16	0 01:19	0.13
24	STORAGE	0.00	0.04	54.76	0 01:21	0.04

 Node Inflow Summary

Node	Type	Maximum Lateral Inflow LPS	Maximum Total Inflow LPS	Time of Max Occurrence days hr:min	Lateral Inflow Volume 10 ⁶ ltr	Total Inflow Volume 10 ⁶ ltr	Flow Balance Error Percent
STM104	JUNCTION	0.00	248.70	0 01:19	0	0.432	0.006
STM103	JUNCTION	0.00	247.01	0 01:19	0	0.432	0.013
STM102	JUNCTION	0.00	246.92	0 01:19	0	0.432	-0.041
STM101	JUNCTION	0.00	246.55	0 01:19	0	0.432	-0.006
STM105	JUNCTION	0.00	42.81	0 01:19	0	0.0657	0.000
STM106	JUNCTION	0.00	42.83	0 01:19	0	0.0657	-0.001
MJR-107	JUNCTION	44.06	44.06	0 01:19	0.0661	0.0661	-0.013
DUMMY	JUNCTION	0.00	22.30	0 01:21	0	0.0901	0.004

5YR.rpt

MJR-103	JUNCTION	0.00	18.21	0	01:19	0	0.00491	6.643
19	OUTFALL	0.00	246.58	0	01:20	0	0.432	0.000
20	OUTFALL	0.00	22.30	0	01:21	0	0.0901	0.000
21	OUTFALL	0.00	14.54	0	01:20	0	0.0046	0.000
MJR-105	STORAGE	227.46	228.69	0	01:19	0.37	0.371	-0.088
24	STORAGE	64.55	64.55	0	01:19	0.0901	0.0901	-0.001

Node Surcharge Summary

No nodes were surcharged.

Node Flooding Summary

No nodes were flooded.

Storage Volume Summary

Storage Unit	Average Volume 1000 m3	Avg Pcnt Full	Evap Pcnt Loss	Exfil Pcnt Loss	Maximum Volume 1000 m3	Max Pcnt Full	Time of Max Occurrence days hr:min	Maximum Outflow LPS
MJR-105	0.000	1	0	0	0.009	43	0 01:19	224.08
24	0.002	1	0	0	0.037	16	0 01:21	22.30

Outfall Loading Summary

Outfall Node	Flow Freq Pcnt	Avg Flow LPS	Max Flow LPS	Total Volume 10^6 ltr
19	36.16	13.83	246.58	0.432
20	22.74	4.59	22.30	0.090
21	1.83	2.90	14.54	0.005
System	20.24	21.31	283.26	0.527

Link Flow Summary

Link	Type	Maximum Flow LPS	Time of Max Occurrence days hr:min	Maximum Veloc m/sec	Max/ Full Flow	Max/ Full Depth
26	CONDUIT	42.81	0 01:19	1.25	0.15	0.27
27	CONDUIT	42.81	0 01:19	1.22	0.14	0.27
30	CONDUIT	246.92	0 01:19	1.38	0.60	0.77
31	CONDUIT	246.55	0 01:19	1.22	0.56	0.67
32	CONDUIT	246.58	0 01:20	1.50	0.56	0.56
MJR-PERLY-2	CHANNEL	18.21	0 01:19	0.72	0.02	0.20
MJR-PERLY-1	CHANNEL	1.23	0 01:19	0.36	0.00	0.14
34	CHANNEL	0.00	0 00:00	0.00	0.00	0.00
35	CONDUIT	22.30	0 01:21	0.52	0.00	0.01
MJR-BOOTH	CHANNEL	14.54	0 01:20	0.60	0.01	0.16
38	CONDUIT	247.01	0 01:19	2.30	0.71	0.64
1	ORIFICE	96.27	0 01:19			
36	ORIFICE	42.83	0 01:19			
3	DUMMY	109.63	0 01:19			
2	DUMMY	22.30	0 01:21			

 Flow Classification Summary

Conduit	Adjusted /Actual Length	Fraction of Time in Flow Class								
		Dry	Up Dry	Down Dry	Sub Crit	Sup Crit	Up Crit	Down Crit	Norm Ltd	Inlet Ctrl
26	1.00	0.02	0.00	0.00	0.00	0.00	0.00	0.98	0.00	0.00
27	1.00	0.02	0.00	0.00	0.00	0.00	0.00	0.98	0.00	0.00
30	1.00	0.02	0.00	0.00	0.02	0.03	0.00	0.94	0.00	0.00
31	1.00	0.02	0.00	0.00	0.00	0.00	0.00	0.97	0.00	0.00
32	1.00	0.02	0.00	0.00	0.80	0.17	0.00	0.00	0.00	0.00
MJR-PERLY-2	1.00	0.05	0.94	0.00	0.00	0.01	0.00	0.00	0.94	0.00
MJR-PERLY-1	1.00	0.99	0.00	0.00	0.00	0.00	0.00	0.00	0.95	0.00
34	1.00	0.76	0.24	0.00	0.00	0.00	0.00	0.00	0.00	0.00
35	1.00	0.76	0.01	0.00	0.00	0.24	0.00	0.00	0.01	0.00
MJR-BOOTH	1.00	0.05	0.00	0.00	0.80	0.15	0.00	0.00	0.90	0.00
38	1.00	0.02	0.00	0.00	0.00	0.00	0.00	0.98	0.00	0.00

 Conduit Surcharge Summary

No conduits were surcharged.

Analysis begun on: Fri Jun 29 11:44:15 2018
 Analysis ended on: Fri Jun 29 11:44:16 2018
 Total elapsed time: 00:00:01

EPA STORM WATER MANAGEMENT MODEL - VERSION 5.1 (Build 5.1.012)

WARNING 03: negative offset ignored for Link 38
 WARNING 02: maximum depth increased for Node MJR-107

 NOTE: The summary statistics displayed in this report are based on results found at every computational time step, not just on results from each reporting time step.

 Analysis Options

Flow Units LPS
 Process Models:
 Rainfall/Runoff YES
 RDII NO
 Snowmelt NO
 Groundwater NO
 Flow Routing YES
 Ponding Allowed YES
 Water Quality NO
 Infiltration Method HORTON
 Flow Routing Method DYNWAVE
 Starting Date 01/01/2000 00:01:00
 Ending Date 01/02/2000 00:00:00
 Antecedent Dry Days 0.0
 Report Time Step 00:01:00
 Wet Time Step 00:01:00
 Dry Time Step 00:01:00
 Routing Time Step 2.00 sec
 Variable Time Step YES
 Maximum Trials 8
 Number of Threads 1
 Head Tolerance 0.001524 m

	Volume	Depth
Runoff Quantity Continuity	hectare-m	mm
*****	-----	-----
Total Precipitation	0.098	75.998
Evaporation Loss	0.000	0.000
Infiltration Loss	0.005	3.622
Surface Runoff	0.092	70.973
Final Storage	0.002	1.456
Continuity Error (%)	-0.070	

	Volume	Volume
Flow Routing Continuity	hectare-m	10^6 ltr
*****	-----	-----
Dry Weather Inflow	0.000	0.000
Wet Weather Inflow	0.092	0.918
Groundwater Inflow	0.000	0.000
RDII Inflow	0.000	0.000
External Inflow	0.000	0.000
External Outflow	0.092	0.918
Flooding Loss	0.000	0.000
Evaporation Loss	0.000	0.000
Exfiltration Loss	0.000	0.000
Initial Stored Volume	0.000	0.000
Final Stored Volume	0.000	0.000
Continuity Error (%)	0.004	

 Highest Continuity Errors

 Node MJR-103 (1.43%)

 Time-Step Critical Elements

None

 Highest Flow Instability Indexes

 All links are stable.

 Routing Time Step Summary

 Minimum Time Step : 0.81 sec
 Average Time Step : 2.00 sec
 Maximum Time Step : 2.00 sec
 Percent in Steady State : 0.00
 Average Iterations per Step : 2.00
 Percent Not Converging : 0.00

 Subcatchment Runoff Summary

Subcatchment	Total Precip mm	Total Runon mm	Total Evap mm	Total Infil mm	Total Runoff mm	Total Runoff 10 ⁶ ltr	Peak Runoff LPS	Runoff Coeff
104B	76.00	0.00	0.00	3.39	71.18	0.64	419.43	0.937
104A	76.00	0.00	0.00	6.60	68.18	0.16	113.94	0.897
FUT	76.00	0.00	0.00	0.47	74.04	0.11	75.76	0.974

 Node Depth Summary

Node	Type	Average Depth Meters	Maximum Depth Meters	Maximum HGL Meters	Time of Max Occurrence days hr:min	Reported Max Depth Meters
STM104	JUNCTION	0.02	0.61	51.90	0 01:29	0.61
STM103	JUNCTION	0.02	0.62	50.13	0 01:30	0.62
STM102	JUNCTION	0.03	0.62	49.83	0 01:30	0.62
STM101	JUNCTION	0.02	0.44	49.55	0 01:30	0.44
STM105	JUNCTION	0.01	0.20	51.90	0 01:30	0.20
STM106	JUNCTION	0.01	0.15	52.10	0 01:29	0.15
MJR-107	JUNCTION	0.00	0.05	53.54	0 01:29	0.05
DUMMY	JUNCTION	0.00	0.01	54.36	0 01:29	0.01
MJR-103	JUNCTION	0.00	0.06	51.67	0 01:29	0.06
19	OUTFALL	0.02	0.38	49.38	0 01:30	0.38
20	OUTFALL	0.00	0.01	53.69	0 01:29	0.01
21	OUTFALL	0.00	0.06	50.48	0 01:29	0.05
MJR-105	STORAGE	0.01	0.16	53.19	0 01:29	0.16
24	STORAGE	0.00	0.06	54.78	0 01:29	0.06

 Node Inflow Summary

Node	Type	Maximum Lateral Inflow LPS	Maximum Total Inflow LPS	Time of Max Occurrence days hr:min	Lateral Inflow Volume 10 ⁶ ltr	Total Inflow Volume 10 ⁶ ltr	Flow Balance Error Percent
STM104	JUNCTION	0.00	367.43	0 01:28	0	0.705	-0.005
STM103	JUNCTION	0.00	344.53	0 01:29	0	0.705	0.007
STM102	JUNCTION	0.00	344.43	0 01:30	0	0.705	-0.009
STM101	JUNCTION	0.00	344.44	0 01:30	0	0.705	-0.003
STM105	JUNCTION	0.00	64.31	0 01:28	0	0.108	-0.026
STM106	JUNCTION	0.00	64.33	0 01:29	0	0.108	0.172
MJR-107	JUNCTION	75.76	75.76	0 01:29	0.113	0.113	-0.028
DUMMY	JUNCTION	0.00	59.95	0 01:29	0	0.16	0.002

100-YR.rpt

MJR-103	JUNCTION	0.00	121.25	0	01:29	0	0.0542	1.452
19	OUTFALL	0.00	344.51	0	01:30	0	0.705	0.000
20	OUTFALL	0.00	59.94	0	01:29	0	0.16	0.000
21	OUTFALL	0.00	117.23	0	01:29	0	0.0534	0.000
MJR-105	STORAGE	419.43	430.86	0	01:29	0.645	0.65	-0.121
24	STORAGE	113.94	113.94	0	01:29	0.16	0.16	-0.001

Node Surge Summary

Surcharging occurs when water rises above the top of the highest conduit.

Node	Type	Hours Surcharged	Max. Height Above Crown Meters	Min. Depth Below Rim Meters
STM102	JUNCTION	0.11	0.020	2.170

Node Flooding Summary

No nodes were flooded.

Storage Volume Summary

Storage Unit	Average Volume 1000 m3	Avg Pcnt Full	Evap Pcnt Loss	Exfil Pcnt Loss	Maximum Volume 1000 m3	Max Pcnt Full	Time of Max Occurrence days hr:min	Maximum Outflow LPS
MJR-105	0.000	1	0	0	0.012	59	0 01:29	426.36
24	0.003	1	0	0	0.064	27	0 01:29	59.95

Outfall Loading Summary

Outfall Node	Flow Freq Pcnt	Avg Flow LPS	Max Flow LPS	Total Volume 10^6 ltr
19	37.43	21.80	344.51	0.705
20	24.38	7.58	59.94	0.160
21	2.49	24.85	117.23	0.053
System	21.43	54.23	518.39	0.918

Link Flow Summary

Link	Type	Maximum Flow LPS	Time of Max Occurrence days hr:min	Maximum Veloc m/sec	Max/ Full Flow	Max/ Full Depth
26	CONDUIT	64.31	0 01:28	1.40	0.22	0.35
27	CONDUIT	64.36	0 01:28	1.35	0.21	0.58
30	CONDUIT	344.43	0 01:30	1.59	0.83	1.00
31	CONDUIT	344.44	0 01:30	1.35	0.78	0.84
32	CONDUIT	344.51	0 01:30	1.66	0.78	0.69
MJR-PERLY-2	CHANNEL	121.25	0 01:29	1.07	0.10	0.42
MJR-PERLY-1	CHANNEL	11.43	0 01:29	0.58	0.01	0.30
34	CHANNEL	0.00	0 00:00	0.00	0.00	0.01
35	CONDUIT	59.94	0 01:29	0.78	0.00	0.03
MJR-BOOTH	CHANNEL	117.23	0 01:29	1.02	0.06	0.35
38	CONDUIT	344.53	0 01:29	2.42	0.99	0.90

100-Year Results

1 ORIFICE 177.15 0 01:29
 36 ORIFICE 64.33 0 01:29
 3 DUMMY 128.00 0 01:29
 2 DUMMY 59.95 0 01:29

 Flow Classification Summary

Conduit	Adjusted /Actual Length	Fraction of Time in Flow Class									
		Dry	Up Dry	Down Dry	Sub Crit	Sup Crit	Up Crit	Down Crit	Norm Ltd	Inlet Ctrl	
26	1.00	0.02	0.00	0.00	0.00	0.00	0.00	0.98	0.00	0.00	
27	1.00	0.02	0.00	0.00	0.00	0.00	0.00	0.98	0.00	0.00	
30	1.00	0.02	0.00	0.00	0.03	0.04	0.00	0.91	0.00	0.00	
31	1.00	0.02	0.00	0.00	0.01	0.00	0.00	0.97	0.00	0.00	
32	1.00	0.02	0.00	0.00	0.78	0.19	0.00	0.00	0.00	0.00	
MJR-PERLY-2	1.00	0.06	0.93	0.00	0.00	0.01	0.00	0.00	0.94	0.00	
MJR-PERLY-1	1.00	0.98	0.01	0.00	0.01	0.00	0.00	0.00	0.94	0.00	
34	1.00	0.75	0.25	0.00	0.00	0.00	0.00	0.00	0.00	0.00	
35	1.00	0.74	0.01	0.00	0.00	0.25	0.00	0.00	0.01	0.00	
MJR-BOOTH	1.00	0.06	0.00	0.00	0.79	0.16	0.00	0.00	0.89	0.00	
38	1.00	0.02	0.00	0.00	0.00	0.00	0.00	0.98	0.00	0.00	

 Conduit Surge Summary

Conduit	Hours Full			Hours Above Full	Hours Capacity
	Both Ends	Upstream	Dnstream	Normal Flow	Limited
30	0.13	0.13	0.15	0.01	0.13
31	0.01	0.11	0.01	0.01	0.01
38	0.01	0.08	0.01	0.01	0.01

Analysis begun on: Fri Jun 29 11:33:52 2018
 Analysis ended on: Fri Jun 29 11:33:53 2018
 Total elapsed time: 00:00:01

DRAWINGS / FIGURES



SITE

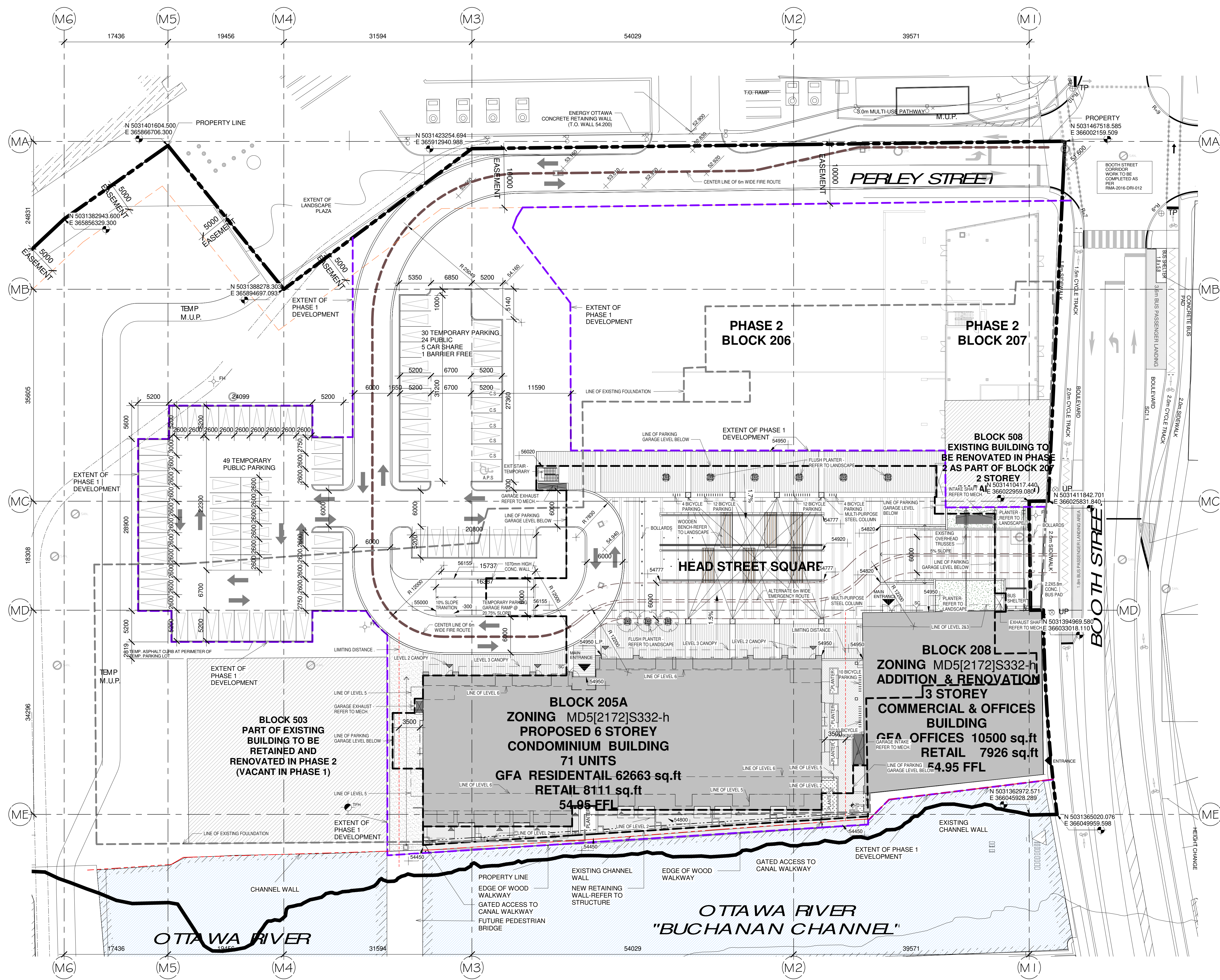

LEGEND

- PROPERTY LINE
- PROPERTY EASEMENT LINE
- BUILDING FACE LIMITING DISTANCE
- PHASE 1 LIMITS
- CENTER LINE OF 6m WIDE FIRE ROUTE
- ALTERNATE EMERGENCY ROUTE
- EXISTING BUILDINGS LIMIT
- EXISTING CHANNEL WALL
- EXCAVATION LINE
- PROPOSED BUILDINGS
- EXISTING BUILDING TO BE RETAINED
- BAVING-SEE LANDSCAPE
- PLANTER-SEE LANDSCAPE
- OPEN WATER
- PROPOSED FIRE HYDRANT LOCATION
- TEMPORARY FIRE HYDRANT LOCATION
- PROPOSED SIAMASE CONNECTION LOCATION
- WATER METER
- SANITARY MANHOLE
- STORM MANHOLE
- CATCH BASIN
- TRENCH DRAIN
- EXISTING LIGHT POLE
- C.S. CAR SHARE PARKING SPACE
- A.P.S. ACCESSIBLE PUBLIC PARKING SPACE
- P.S. PUBLIC PARKING SPACE
- TP TRAFFIC POLE
- UP EXISTING UTILITY POLE
- EBR PUBLIC BIKE PARKING

PHASE 1 ZONING TABLE

CURRENT ZONING	MD5 [2172] S332-h	
TOTAL PHASE 1 SITE AREA	10,938 m ²	
TEMPORARY OVERFLOW PARKING AREA - PHASE 1	1,747 m ²	
PHASE 1 No. OF DWELLING UNITS	71 DWELLING UNITS	
PHASE 1 RESIDENTIAL - 205A	6,250 m ²	
PHASE 1 RETAIL AREA - 205A	768 m ²	
PHASE 1 RETAIL AREA - 208	1,457 m ²	
PHASE 1 OFFICE AREA - 208	1,298 m ²	
PHASE 1 Restaurant - 208	100 m ²	
PHASE 1 GROSS FLOOR AREA	9,873 m ²	
SETBACKS	ALL SDBS: NO MINIMUMS	REFER TO SITE PLAN
BUILDING HEIGHTS	73m, maximum 4 buildings over nine (9) storeys within Area A on Schedule 332	Block 205A: 6 Storeys-19.7m Block 208: 3 Storeys-15m Block 301: underground parking garage
REQUIRED		PROVIDED
AMENITY AREA 6m ² PER UNIT 50% TO BE COMMUNAL (213m ²) 428m ² Required	TOTAL REQUIRED AMENITY: 428m ² TOTAL COMMON AMENITY: 276.9m ²	TOTAL: 1110m ² private balconies/terraces: 834m ² Total common amenity space: 276.9m ² Indoor level 3 (fitness room): 27.7m ² Basement level: 47.2m ² Outdoor (part of head street square): 202 m ²
PARKING RESIDENTIAL + VISITOR: MINIMUM: NONE MAXIMUM: 1.5/DWELLING UNIT	MIN REQUIRED: RESIDENTIAL + VISITOR: NONE RETAIL: NONE OFFICE: 10 SPACES RESTAURANT: NONE	RESIDENTIAL + VISITOR: 71 SPACES RETAIL: 22 SPACES OFFICE: 13 SPACES RESTAURANT: 202 SPACES TOTAL: 307 SPACES
OFFICE: MINIMUM: 0.75/100M2 OF GFA MAXIMUM: 1.0/100M2 OF GFA	MAXIMUM PERMITTED: RESIDENTIAL + VISITOR: 107 SPACES RETAIL: 22 SPACES OFFICE: 13 SPACES RESTAURANT: NO MAXIMUM	LOCATION: BLOCK 301 (P1): 67 SPACES BLOCK 301 (P2): 70 SPACES BLOCK 205A (P1): 35 SPACES BLOCK 205A (P2): 36 SPACES SURFACE (TEMPORARY): 79 SPACES
RESTAURANT: MINIMUM: NONE MAXIMUM: NONE		
BICYCLE PARKING RETAIL: 1/250M2 OF GFA RESTAURANT: 1/1,500M2 OF GFA 50% CAN BE VERTICAL	TOTAL REQUIREMENT: 81 SPACES RESIDENTIAL: 71 SPACES RETAIL: 4 SPACES OFFICE: 6 SPACES	TOTAL RESIDENTIAL PROPOSED: 71 SPACES RESIDENTIAL INTERIOR: 71 SPACES Interior vertical: 30 spaces Interior horizontal: 41 spaces PUBLIC EXTERIOR SPACES: 112 SPACES

1 000-SITE PLAN -PHASE 1 -Scale 1 300
A.003 SCALE: 1 : 300

PROJECT TEAM
PLANNING
 PATERN CONSULTANTS INC.
 PAUL BLACK
 MIGUEL TREMBLAY
 613.730.5709
ARCHITECT
 HOBIN ARCHITECTURE INC.
 GORD LORIMER
 613.238.7200
STRUCTURAL
 GSP / HILL SALL
 SCOTT FUNNELL
 613.907.7532
CIVIL
 DAVID SHAEFFER ENGINEERING LTD
 ADAM FORBET
 613.836.0856 x231
LANDSCAPE ARCHITECT
 PROJET PAYSAGE
 SERGE GALLANT
 514.849.7700
TRANSPORTATION
 PARSONS
 RONALD JACK
 613.238.4180
SITE WIDE ELECTRICAL
 SPECTRUM ENGINEERING LTD
 DUANE WATE
 613.497.3111 x228
SITE WIDE MECHANICAL
 HOBIN ARCHITECTURE & ASSOCIATES
 LIMITED
 ROBERT LEFEBVRE
 613.727.5111 x234
GEOTECHNICAL
 WATSON'S GROUP
 CARLOS DASILVA
 613.238.7381
LAND SURVEYOR
 STRATTEC SURVEYING LTD.
 CHARLES TALLEY / BRIAN WERSTER
 613.722.4420

APPROVED	REVISION
DATE	BY
18	08/18

It is the responsibility of the appropriate contractor to check and verify all dimensions on site and report all errors and/or omissions to the engineer.
 All contractors must comply with all applicable codes and regulations.
 This drawing may not be used for construction without the engineer's signed approval.
 Copyright reserved.



Hobin Architecture Incorporated
 63 Pamela Street
 Ottawa, Ontario
 Canada K1S 3K7
 T: 613-238-7200
 F: 613-235-2055
 E: mail@hobin.com
 hobinarc.com
HOBIN ARCHITECTURE

Chaudiere Island West - Phase 1
 4 BOOTH ST. Ottawa, Ontario

PHASE 1 SITE PLAN	
TITLE	DATE
Author	05/08/18
SCALE	As Indicated
PROJECT	1808.00
DRAWING NO.	A.003
REVISION NO.	A

47856-B

HULL - OTTAWA DOMTAR MILLS - SANITARY EFFLUENT SYSTEMS

SCALE 1" = 200'

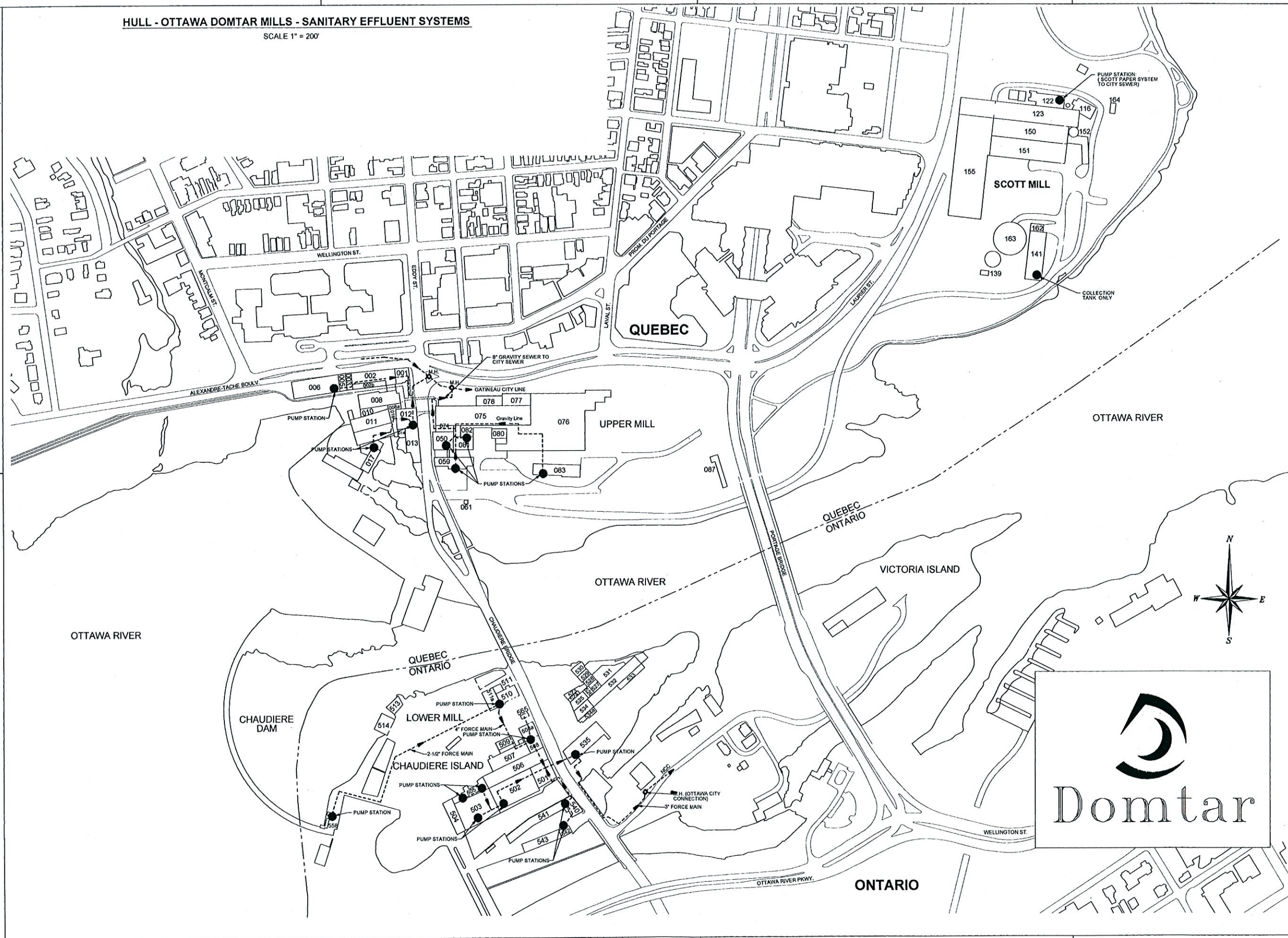

DWG. NO.	REFERENCE	
DATE	REVISION	
Jan 12/05	Sanitary Lines Revised	
JFL		
DEPT.	EQ. CLASS	EQ. NO.
DESIGN CODE		
DRAWN	RDB	NOV 20/2004
PROJECT		
DES. ENG.		
APPROVAL		
MILL	ALL	
DEPT.		
BLDG	ALL	
TITLE		
SANITARY EFFLUENT SYSTEMS		
DWG TYPE	SITE	
PROJECT	SCALE	
	1" = 200'	
47856-B	REV.	