

**LOCATION PLAN**  
NTS

**LEGEND**

PROPERTY LINE	---
LIMIT OF CONSTRUCTION	---
PROPOSED ROOF PERIMETER	---
EXISTING GRADE	x 149.40EX
PROPOSED GRADE	x 148.22
PROPOSED GRADE (TOP OF CURB)	x 148.53TC
PROPOSED GRADE (BOTTOM OF CURB)	x 148.43BC
PROPOSED GRADE (TOP OF WALL)	x 149.39TW
PROPOSED GRADE (BOTTOM OF WALL)	x 148.29BW
PROPOSED STORM TANK ACCESS HATCH	⊗
PROPOSED STORM ACCESS HATCH	⊙
PROPOSED SANITARY ACCESS HATCH	⊕
PROPOSED SAMPLING ACCESS POINT	⊖
PROPOSED AREA DRAIN	⊗
EMERGENCY OVERLAND FLOW ROUTE	→
PROPOSED TRENCH DRAIN	---

**LIST OF DRAWINGS**

SG-01 (SITE GRADING PLAN)
SS-01 (SITE SERVING PLAN)
EC-01 (EROSION CONTROL PLAN)
DD-01 (DETAIL DRAWINGS)

**SITE PLAN INFORMATION**  
 HOBIN ARCHITECTURE INC.  
 63 PAMILLA STREET, OTTAWA, ONTARIO,  
 CANADA K1S 3K7  
 PHONE: (613) 238-7200  
 EMAIL: mail@hobinarc.com

**SURVEY INFORMATION**  
 STANTEC GEOMATICS LTD.  
 400-1331 CLYDE AVENUE  
 OTTAWA ON  
 PHONE: (613) 722-4420  
 www.stantec.com

**BENCHMARK**  
 ELEVATIONS SHOWN HEREON ARE GEODETIC (CGVD-1928:1978)  
 AND ARE DERIVED FROM THE CAN-NET VRS NETWORK  
 MONUMENT: OTTAWA ELEVATION=95.230.

NO	REVISION	DATE	BY
1.	ISSUED FOR SITE PLAN APPLICATION	MAY 13, 2022	NM

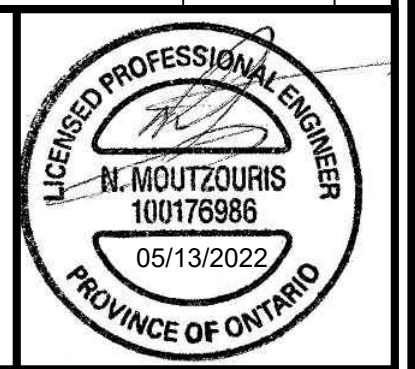

CITY OF OTTAWA

**SITE GRADING PLAN**  
 MIXED-USE DEVELOPMENT  
 70 RICHMOND ROAD  
 OTTAWA, ONTARIO  
 DEVTRIN (ISLAND PARK) INC.



DESIGNED BY: DS	DATE: JUNE, 2020	CHECKED BY: NM
DRAWN BY: DS	PROJECT No:	APPROVED BY: NM
SCALE: 1:100		DRAWING No:
UD18-028		SG-01

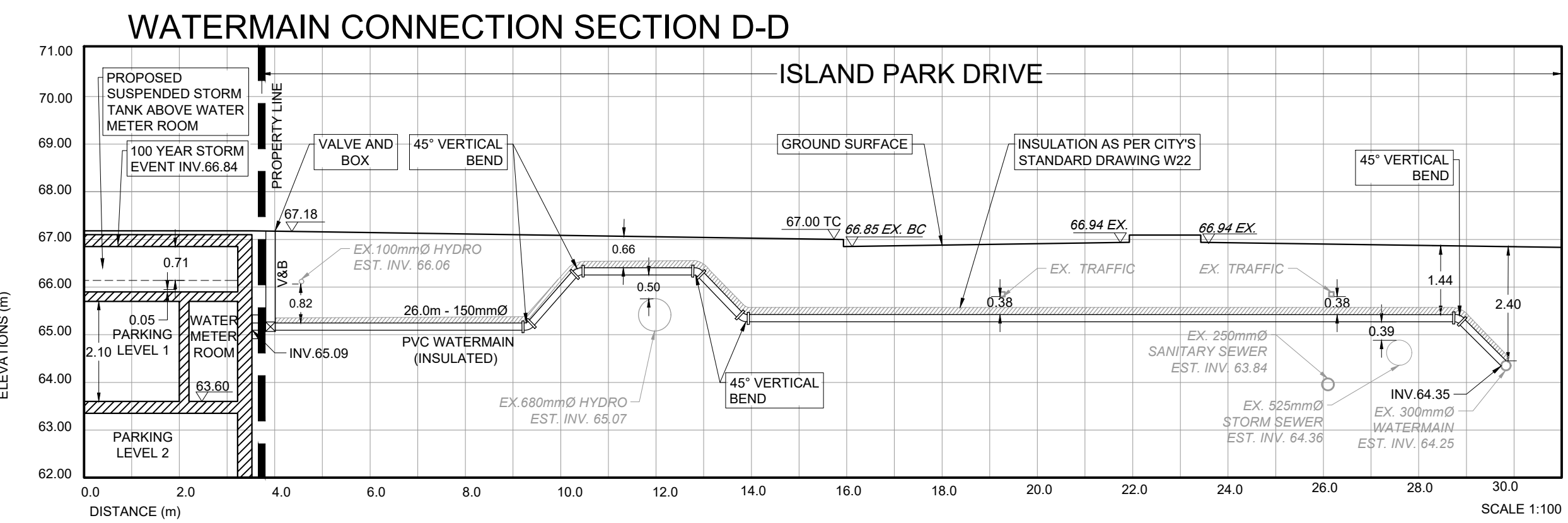
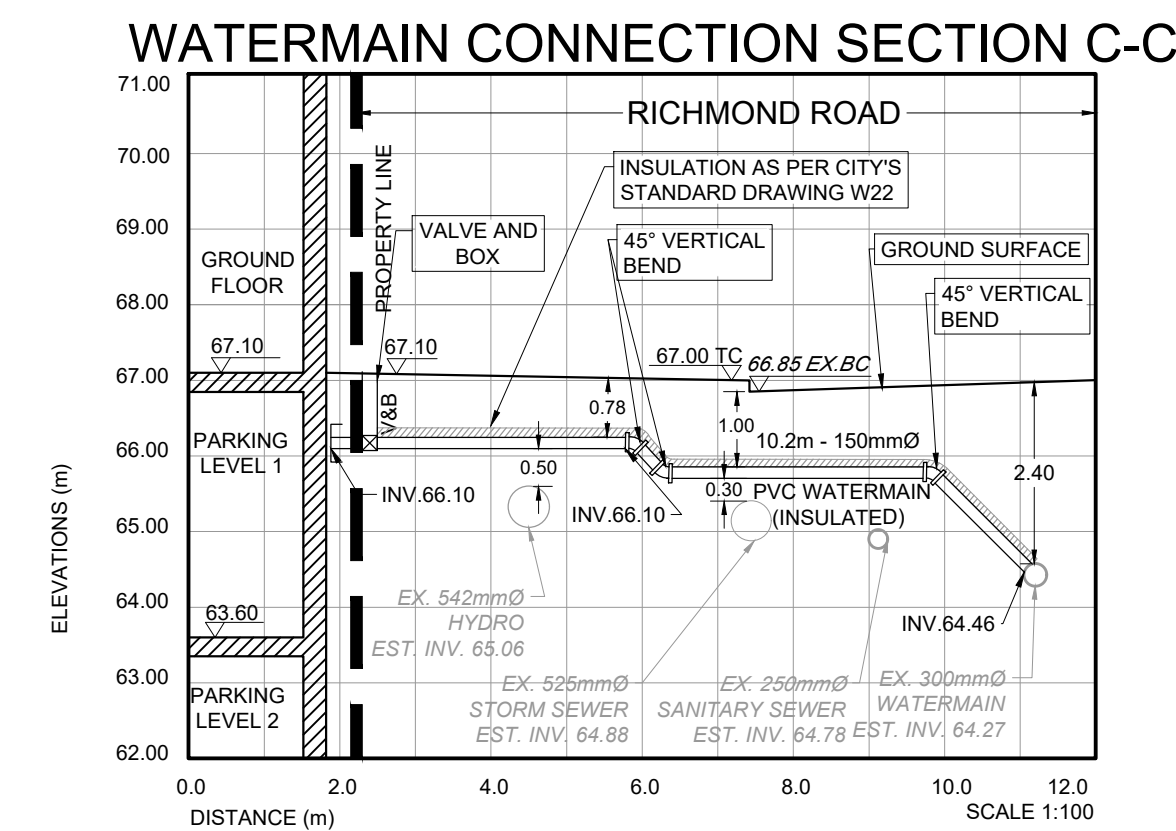
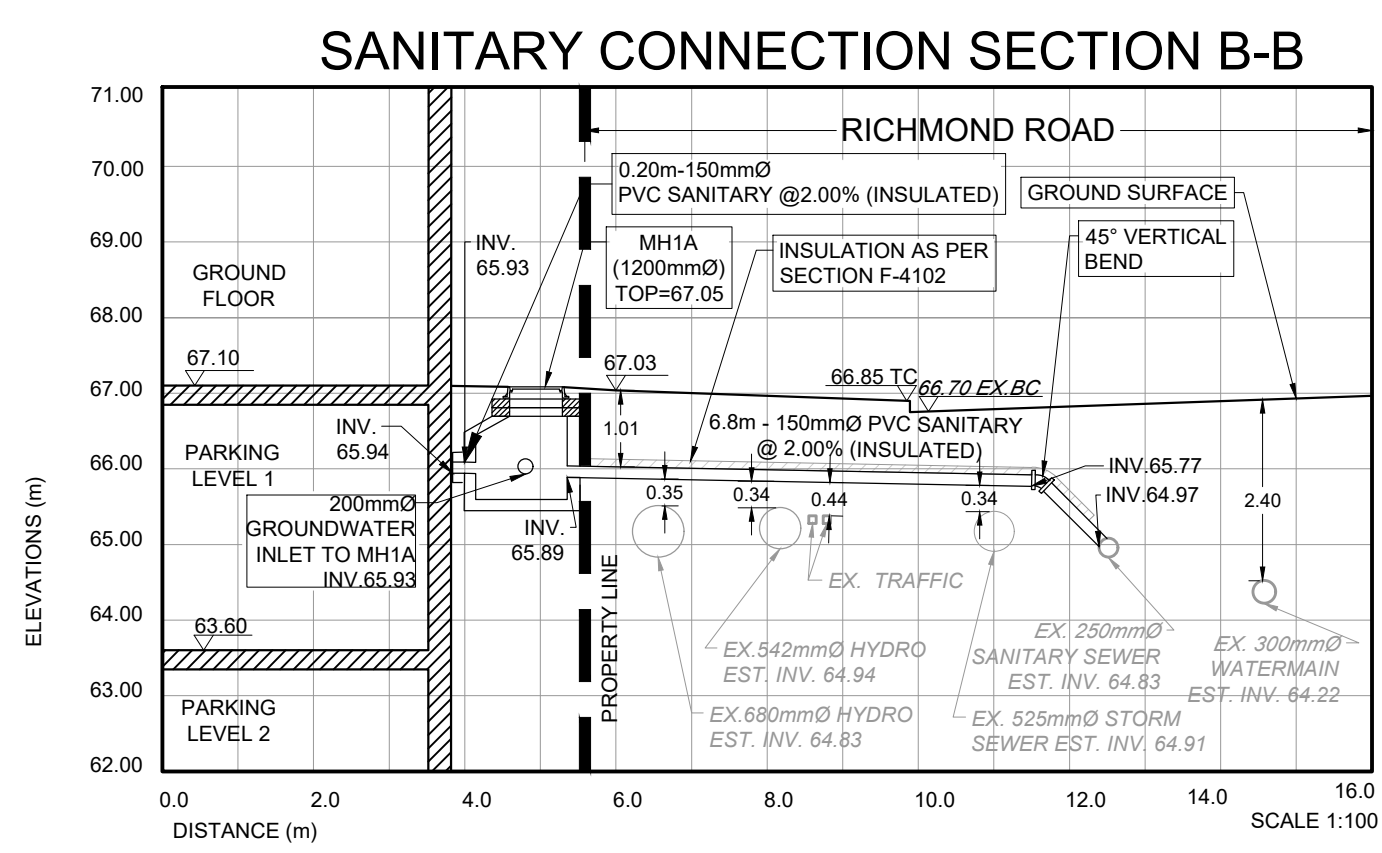
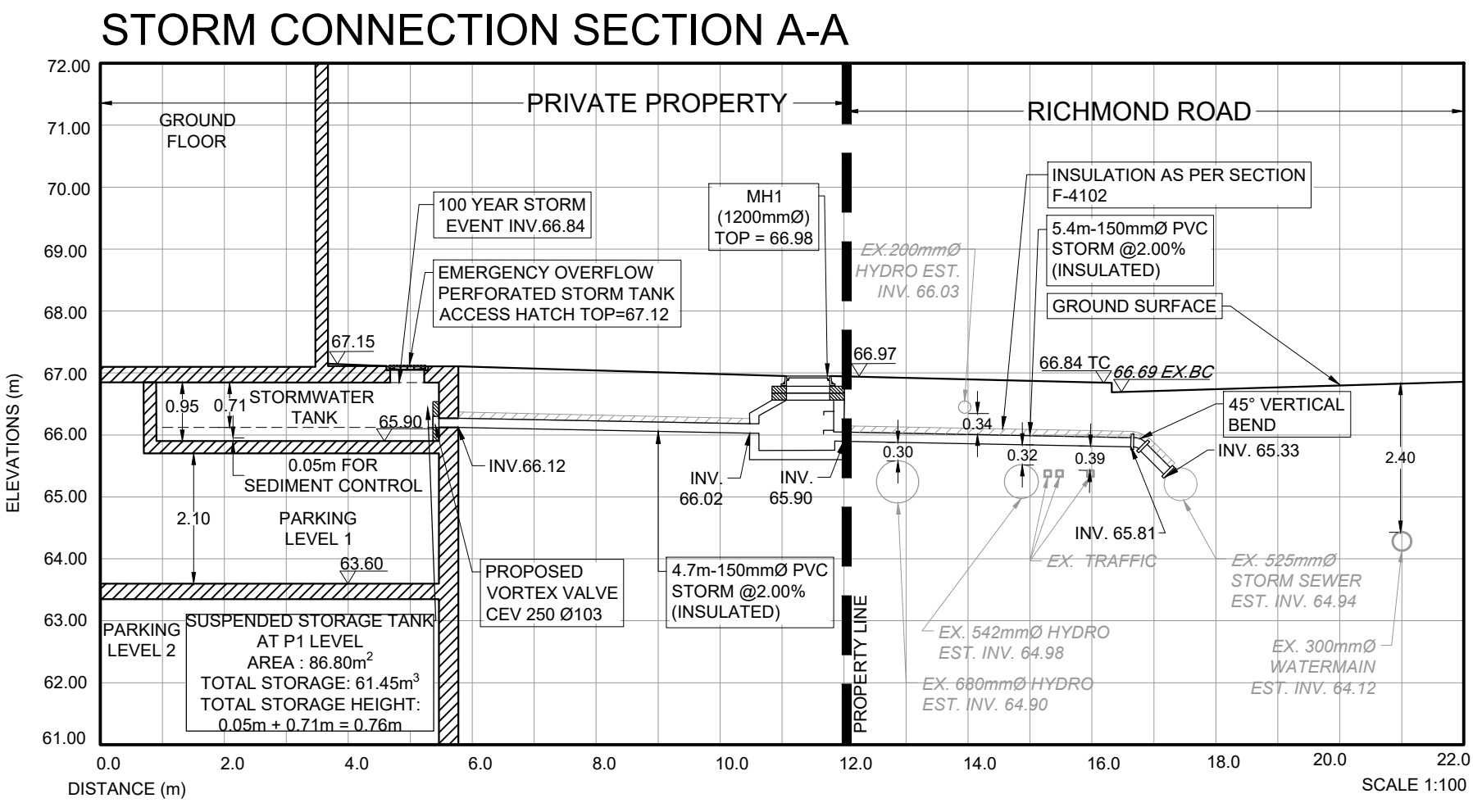
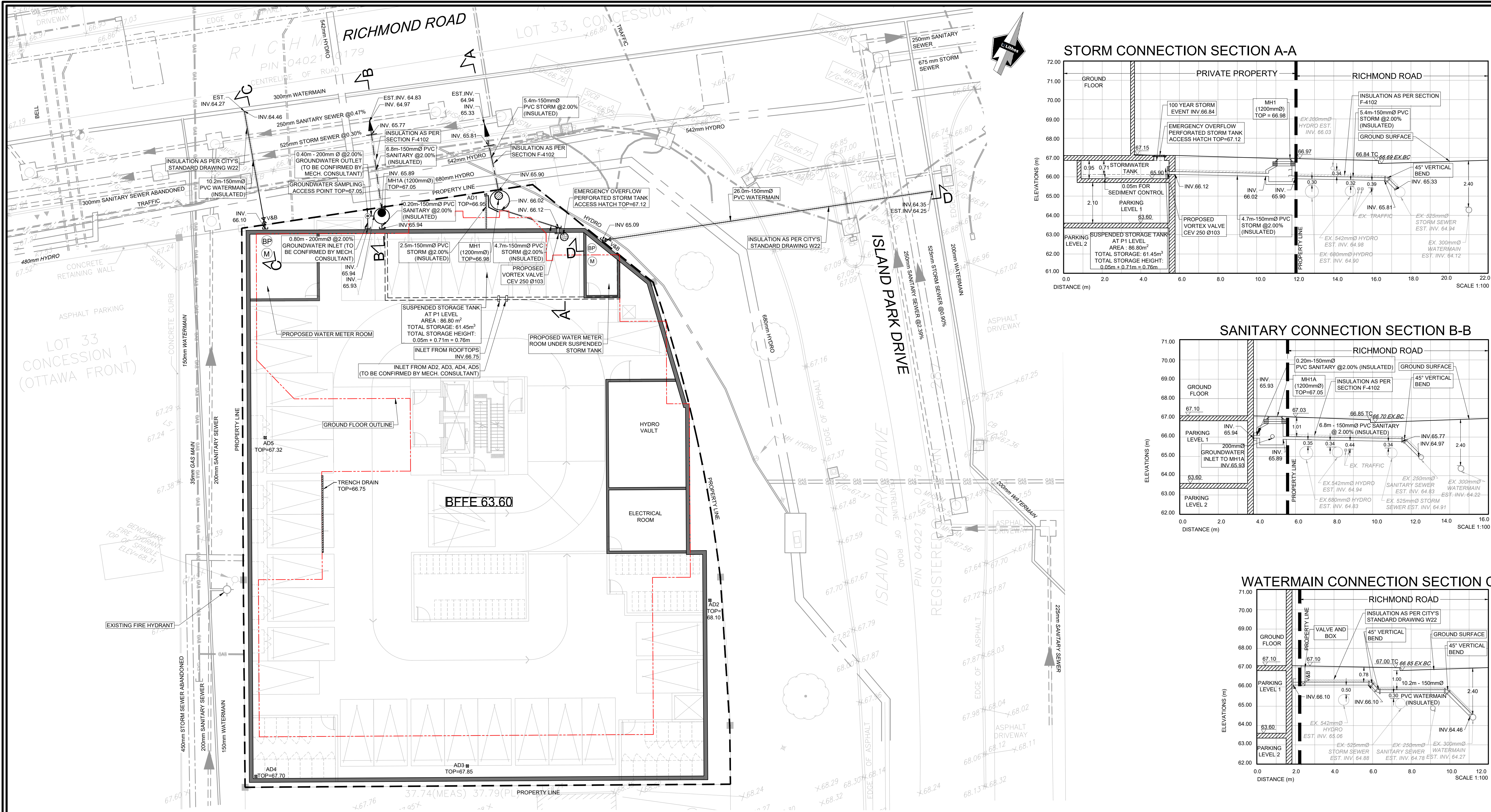

**GENERAL NOTES**

- COORDINATE AND SCHEDULE ALL WORK WITH OTHER TRADES AND CONTRACTORS.
- DETERMINE THE EXACT LOCATION, SIZE, MATERIAL AND ELEVATION OF ALL EXISTING UTILITIES PRIOR TO COMMENCING CONSTRUCTION. PROTECT AND ASSUME RESPONSIBILITY FOR ALL EXISTING UTILITIES WHETHER OR NOT SHOWN ON THIS DRAWING.
- OBTAIN ALL NECESSARY PERMITS AND APPROVALS FROM THE CITY OF OTTAWA BEFORE COMMENCING CONSTRUCTION.
- RESTORE ALL DISTURBED AREAS ON-SITE AND OFF-SITE, INCLUDING TRENCHES AND SURFACES ON PUBLIC ROAD ALLOWANCES TO EXISTING CONDITIONS OR BETTER TO THE SATISFACTION OF THE CITY OF OTTAWA AND ENGINEER.
- REMOVE FROM SITE ALL EXCESS EXCAVATED MATERIAL, ORGANIC MATERIAL AND DEBRIS UNLESS OTHERWISE INSTRUCTED BY ENGINEER. EXCAVATE AND REMOVE FROM SITE ANY CONTAMINATED MATERIAL. ALL CONTAMINATED MATERIAL SHALL BE DISPOSED OF AT A LICENSED LANDFILL FACILITY.
- ALL ELEVATIONS ARE GEODETIC.
- REFER TO ARCHITECT'S AND LANDSCAPE ARCHITECT'S DRAWINGS FOR BUILDING AND HARDSURFACE AREAS AND DIMENSIONS.
- SAW CUT AND KEY GRIND ASPHALT AT ALL ROAD CUTS AND ASPHALT TIE IN POINTS AS PER CITY OF OTTAWA STANDARDS (R10).
- PROVIDE LINE/PARKING PAINTING.

**SEWER NOTES**

- SUPPLY AND CONSTRUCT ALL SEWERS AND APPURTENANCES IN ACCORDANCE WITH THE MOST CURRENT CITY OF OTTAWA STANDARDS AND SPECIFICATIONS.
- SEWER TRENCHING AND BEDDING SHALL CONFORM TO OPSD 802.010 AND 802.013 UNLESS NOTED OTHERWISE.
- PIPE BEDDING, COVER AND BACKFILL ARE TO BE COMPACTED TO AT LEAST 95% OF THE STANDARD PROCTOR MAXIMUM DRY DENSITY. THE USE OF CLEAR CRUSHED STONE AS A BEDDING LAYER SHALL NOT BE PERMITTED.
- SUB-BEDDING, IF REQUIRED SHALL BE AS PER THE DIRECTION OF A GEOTECHNICAL ENGINEER.
- BACKFILL TO AT LEAST 300mm ABOVE TOP OF PIPE WITH GRANULAR "A" OR SAND.
- TO MINIMIZE DIFFERENTIAL FROST HEAVING, TRENCH BACKFILL FROM PAVEMENT SUBGRADE TO 2 METRES BELOW FINISHED GRADE SHALL MATCH EXISTING SOIL CONDITIONS.

- SEWERS AND CONNECTIONS 150mm DIAMETER AND SMALLER TO BE PVC SDR 28 OR APPROVED EQUIVALENT.
- SEWERS AND CONNECTIONS 200mm DIAMETER AND LARGER TO BE PVC SDR 35 OR APPROVED EQUIVALENT.
- INSULATE ALL STORM SEWERS THAT HAVE LESS THAN 1.5m COVER PER INSULATION DETAIL FOR SHALLOW SEWERS, PROVIDE 150mm CLEARANCE BETWEEN PIPE AND INSULATION.
- SUPPLY AND INSTALL ALL PIPING AND APPURTENANCES AS SHOWN AND DETAILED TO WITHIN 1m OF BUILDING. ALL ENDS OF SERVICES TO BE PROPERLY CAPPED AND LOCATED WITH 2"x4"x8' LONG MARKER.
- ALL CATCHBASIN AS WELL AS CATCHBASIN MANHOLES LEADS ARE TO BE 200mmØ, SLOPE TO BE 1% UNLESS OTHERWISE NOTED.
- CONTRACTOR TO PROVIDE THE CONSULTANT WITH A GENERAL PLAN OF SERVICES INDICATING ALL SERVICING AS-BUILT INFORMATION SHOWN ON THIS PLAN. AS-BUILT INFORMATION MUST INCLUDE: PIPE MATERIAL, SIZES, LENGTHS, SLOPES, INVERT AND TIG ELEVATIONS, STRUCTURE LOCATIONS, VALVE AND HYDRANT LOCATIONS, TWM ELEVATIONS AND ANY ALIGNMENT CHANGES, ETC.
- SERVICES ARE TO BE CONSTRUCTED TO 1.0m FROM THE FACE OF BUILDING AT A MINIMUM SLOPE OF 1.0%.
- ALL STORM AND SANITARY LATERALS SHALL BE EQUIPPED WITH BACK FLOW PREVENTION DEVICES AS PER THE CITY OF OTTAWA STANDARD DETAILS S14 AND S14.1 OR S14.2.
- FLEXIBLE CONNECTIONS ARE REQUIRED FOR CONNECTING PIPES TO MANHOLES/FOR EXAMPLE KOR-N-SEAL/PSX-POSITIVE SEAL AND DURASEAL, THE CONCRETE GRADE FOR THE PIPE CAN BE ELIMINATED.
- ALL STORM MANHOLES MANHOLES WITH PIPE SIZES LESS THAN 900mm ARE TO HAVE 300mm SUMPS UNLESS OTHERWISE INDICATED ALL STORM MANHOLES WITH PIPE SIZES 900mm AND LARGER ARE TO BE BENDED.
- CONTRACTOR TO TELEVISION (CCTV) ALL PROPOSED SEWERS 200mm OR GREATER IN DIAMETER PRIOR TO BASE COURSE ASPHALT TO ENSURE THAT THEY ARE CLEAN AND OPERATIONAL UPON COMPLETION OF CONTRACT. THE CONTRACTOR IS RESPONSIBLE TO FLUSH AND CLEAN ALL SEWERS & APPURTENANCES AND RE CCTV PRIOR TO ACCEPTANCE OBTAIN APPROVAL FROM THE CITY'S SEWER OPERATIONS. PROVIDE THE CCTV INFORMATION AND REPORT TO THE ENGINEER FOR REVIEW AND APPROVAL.
- INSULATE ALL STORM AND SANITARY PIPES THAT HAVE LESS THAN 2.0m COVER AS PER CITY OF OTTAWA F-4102.

**SPECIFICATIONS:**

ITEM	SPEC No	REFERENCE
SANITARY/STORM/CATCHBASIN MANHOLE (1200Ø)	701.010	OPSD
CATCHBASIN (600x600)	705.010	OPSD
CATCHBASIN FRAME AND COVER	400.020	OPSD
STORM/SANITARY MH FRAME	S25	CITY OF OTTAWA
SANITARY COVER	S24	CITY OF OTTAWA
STORM COVER (CLOSED)	S24.1	CITY OF OTTAWA
STORM COVER (OPEN)	S28.1	CITY OF OTTAWA
SEWER TRENCH	S6 & S7	CITY OF OTTAWA
STORM SEWER <450mmØ	PVC DR 35(UNLESS SPECIFIED OTHERWISE)	CITY OF OTTAWA
SANITARY SEWER	PVC DR 35	CITY OF OTTAWA

**WATERMAIN NOTES**

- SUPPLY AND CONSTRUCT ALL WATERMAIN AND APPURTENANCES IN ACCORDANCE WITH THE MOST CURRENT CITY OF OTTAWA STANDARDS AND SPECIFICATIONS.
- WATERMANS AND/OR WATER SERVICES ARE TO HAVE A MINIMUM COVER OF 2.4m. OTHERWISE THERMAL INSULATION IS REQUIRED AS PER CITY DWG. No. W22.
- IF THE WATERMAIN MUST BE DEFLECTED TO MEET ALIGNMENT, ENSURE THAT THE AMOUNT OF DEFLECTION USED IS EQUAL TO OR LESS THAN THAT WHICH IS RECOMMENDED BY THE MANUFACTURER.
- USE APPROVED SADDLE CONNECTION WITH MAIN (CORPORATION) STOP AS PER STD DWG W26.
- CONNECTION TO EXISTING BY CITY. EXCAVATION, BACKFILLING AND REINSTATEMENT BY CONTRACTOR.

**SPECIFICATIONS:**

ITEM	SPEC No	REFERENCE
WATERMAIN TRENCHING	W17	CITY OF OTTAWA
THERMAL INSULATION IN SHALLOW TRENCHES	W22, W23	CITY OF OTTAWA
WATERMAIN	PVC DR 18(CLASS 150)	CITY OF OTTAWA
VALVE BOX	W24	CITY OF OTTAWA

DAYLIGHT IS IN PROGRESS. UPON COMPLETION OF THE DAYLIGHTING, ALL INVERTS WILL BE UPDATED ACCORDINGLY.

© 2022 GOOGLE, MAP DATA © 2022 TELE ATLAS

**LOCATION PLAN**

**LEGEND**

- PROPERTY LINE
- GROUND FLOOR OUTLINE
- PROPOSED STORM
- PROPOSED SANITARY
- PROPOSED WATER
- PROPOSED STORMWATER MANHOLE
- PROPOSED SANITARY MANHOLE
- PROPOSED GROUNDWATER SAMPLING ACCESS POINT
- EXISTING MANHOLE
- PROPOSED VALVE AND BOX
- WATER METER
- BACK FLOW PREVENTOR
- EXISTING STORM
- EXISTING SANITARY
- EXISTING WATER
- EXISTING TRAFFIC CABLES
- EXISTING HYDRO LINE
- EXISTING GASMAIN
- EXISTING BELL
- EXISTING FIRE HYDRANT
- EXISTING CATCH BASIN
- PROPOSED INSULATION

**LIST OF DRAWINGS**

- SG-01 (SITE GRADING PLAN)
- SS-01 (SITE SERVICING PLAN)
- EC-01 (EROSION CONTROL PLAN)
- DD-01 (DETAIL DRAWINGS)

**SITE PLAN INFORMATION**

HOBIN ARCHITECTURE INC.  
63 PAMILLA STREET, OTTAWA, ONTARIO,  
Canada K1S 3K7  
PHONE: (613) 238-7200  
EMAIL: mail@hobinarc.com

**SURVEY INFORMATION**

STANTEC GEOMATICS LTD.  
400-1331 CLYDE AVENUE  
OTTAWA ON  
PHONE: (613) 722-4420  
www.stantec.com

**BENCHMARK**

ELEVATIONS SHOWN HEREON ARE GEODETIC (CGVD-1928:1978) AND ARE DERIVED FROM THE CAN-NET VRS NETWORK MONUMENT OTTAWA ELEVATION=95.250.

NO	REVISION	DATE	BY
1.	ISSUED FOR SITE PLAN APPLICATION	MAY 13, 2022	NM

**CITY OF OTTAWA**

**SITE SERVICING PLAN**

MIXED-USE DEVELOPMENT  
70 RICHMOND ROAD  
OTTAWA, ONTARIO  
DEVTRIN (ISLAND PARK) INC.

**Lithos**

150 Berrymore Road, Toronto, Ontario M4A 1Y1

DESIGNED BY: DS	DATE: FEBRUARY, 2016	CHECKED BY: NM
DRAWN BY: DS	PROJECT No:	APPROVED BY: NM
SCALE: 1:150		DRAWING No:

© COPYRIGHT 2022 Lithos Group Ltd.

UD18-028 SS-01

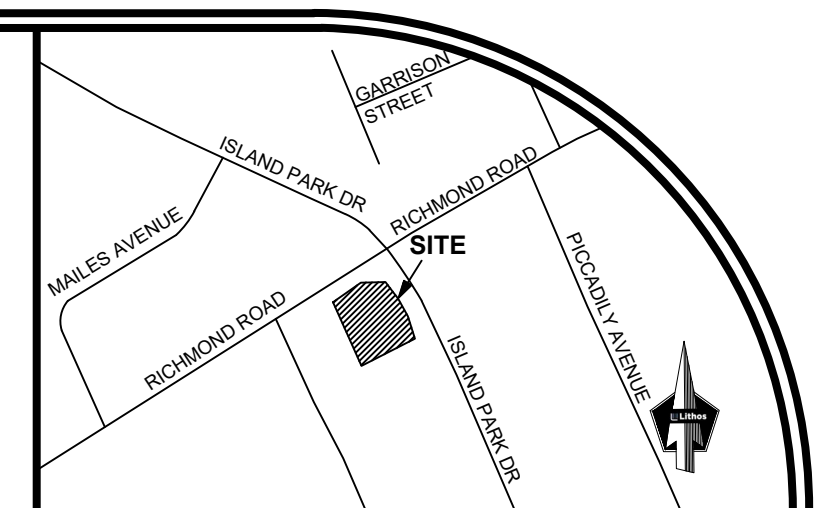
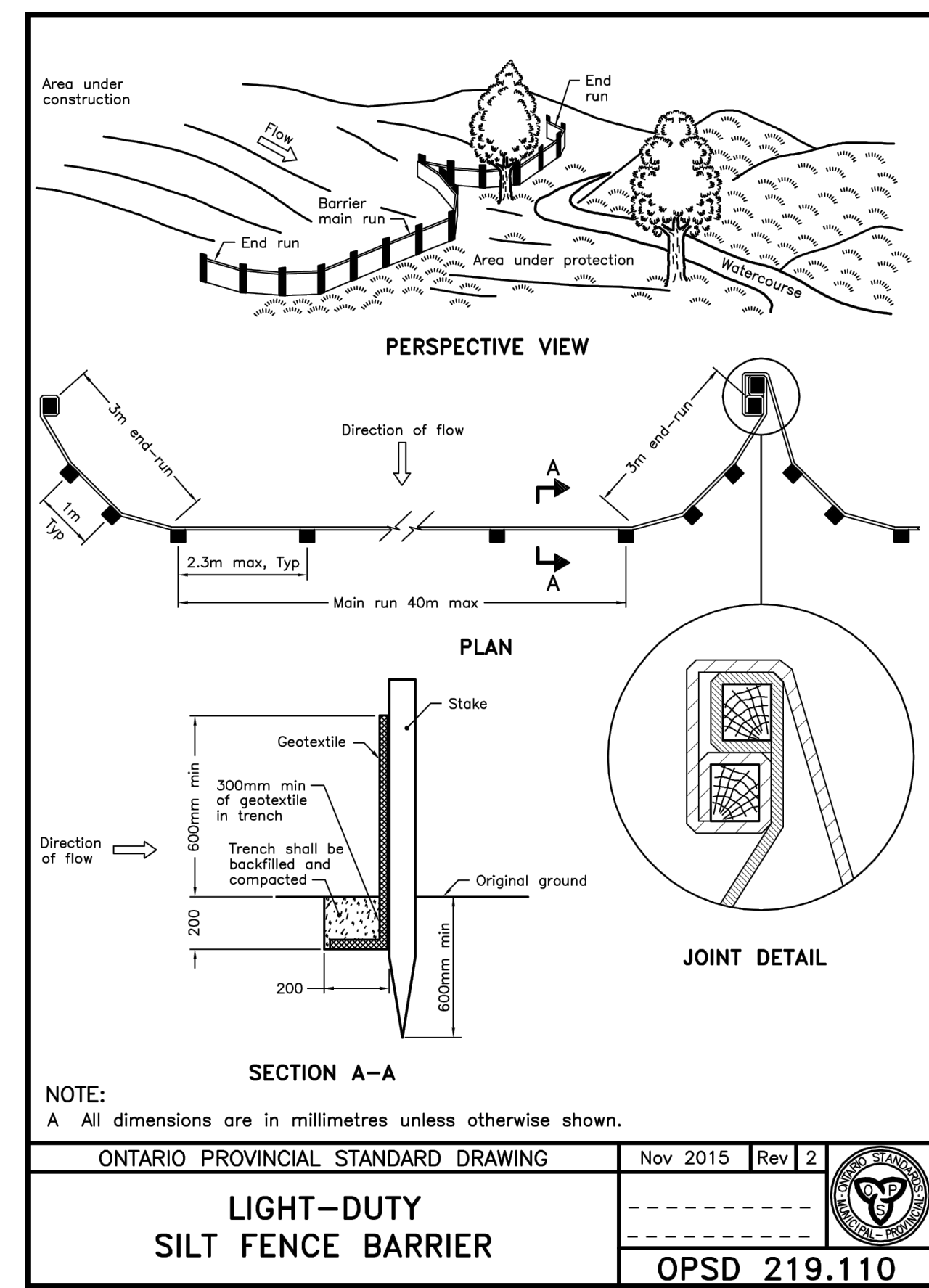
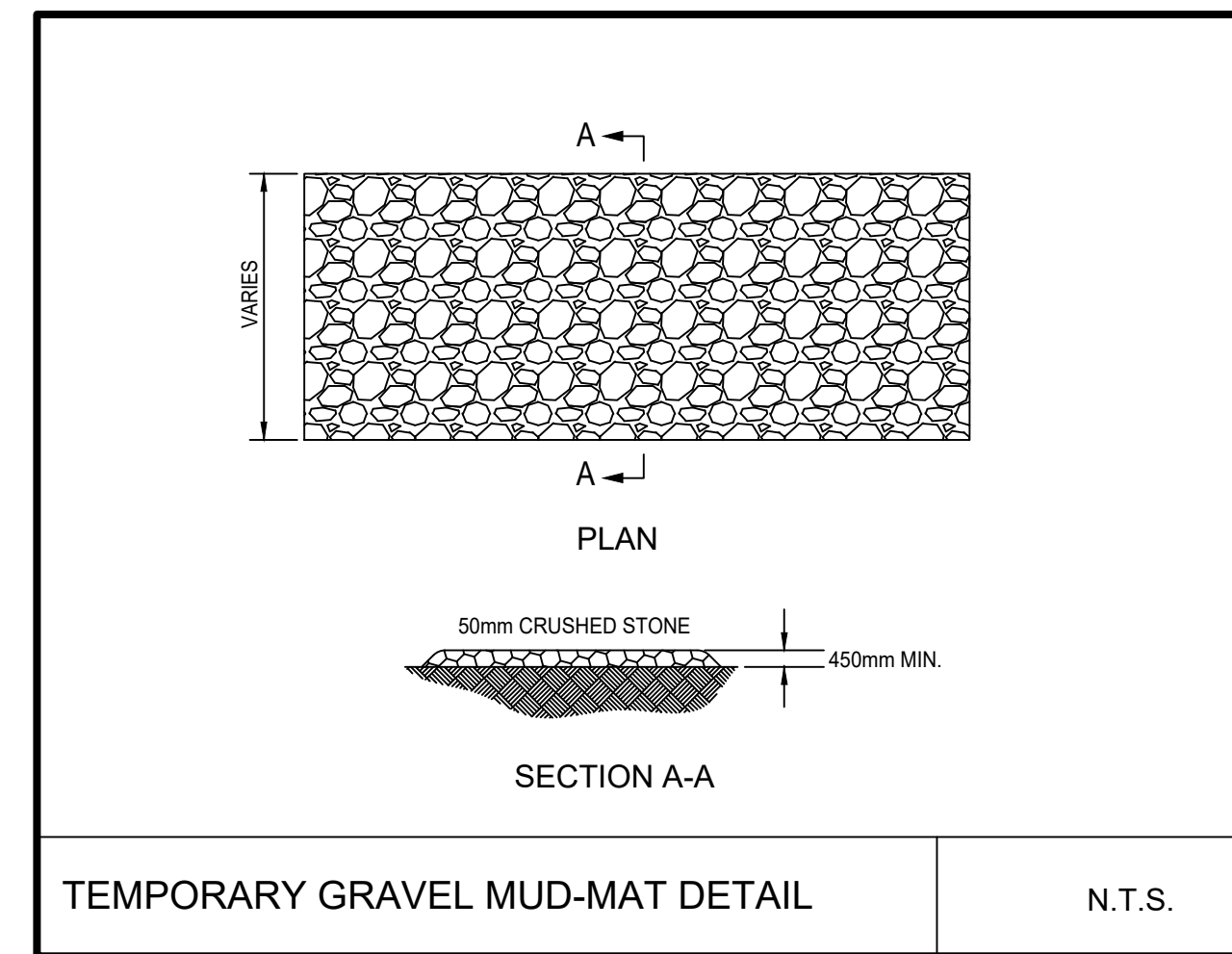
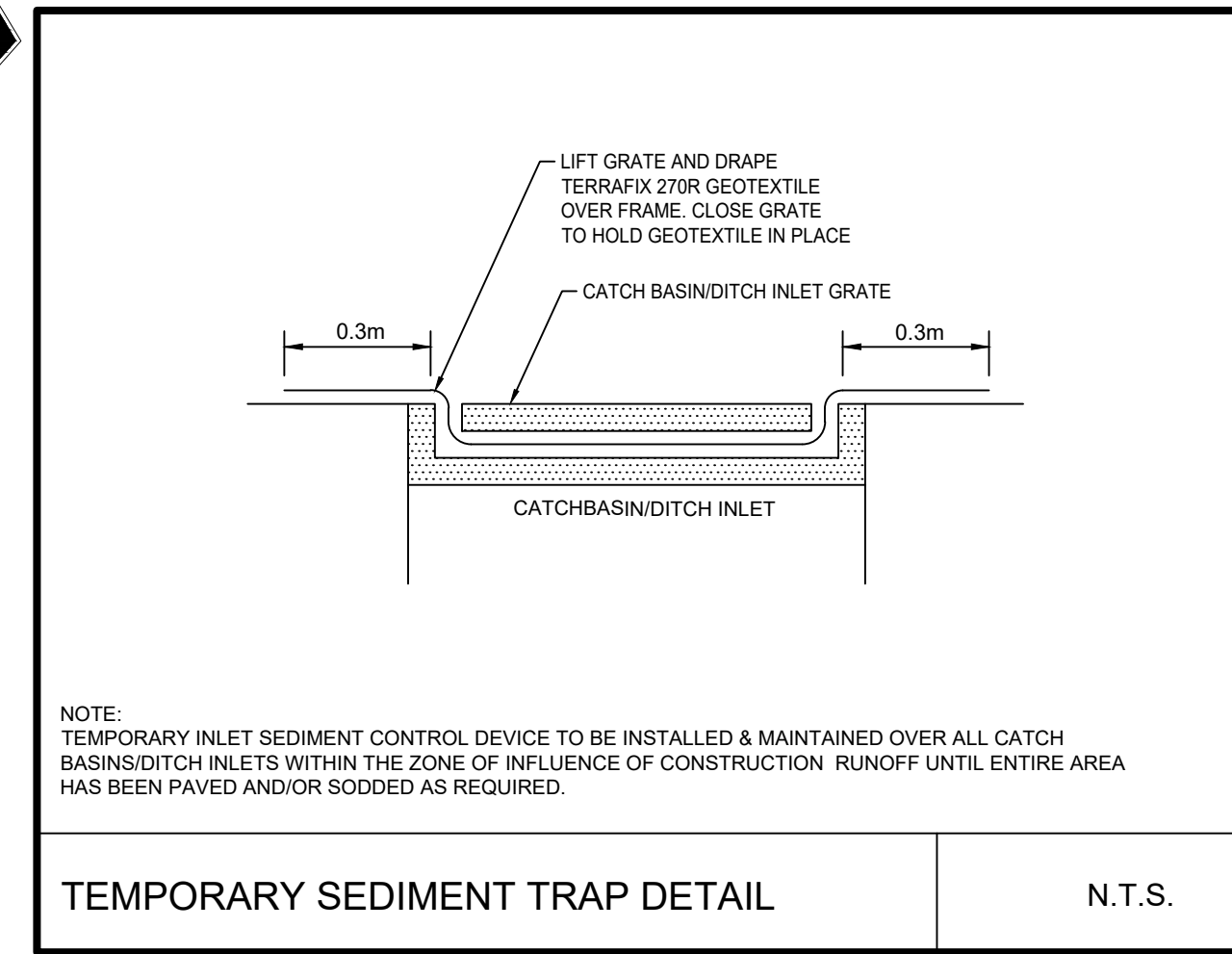
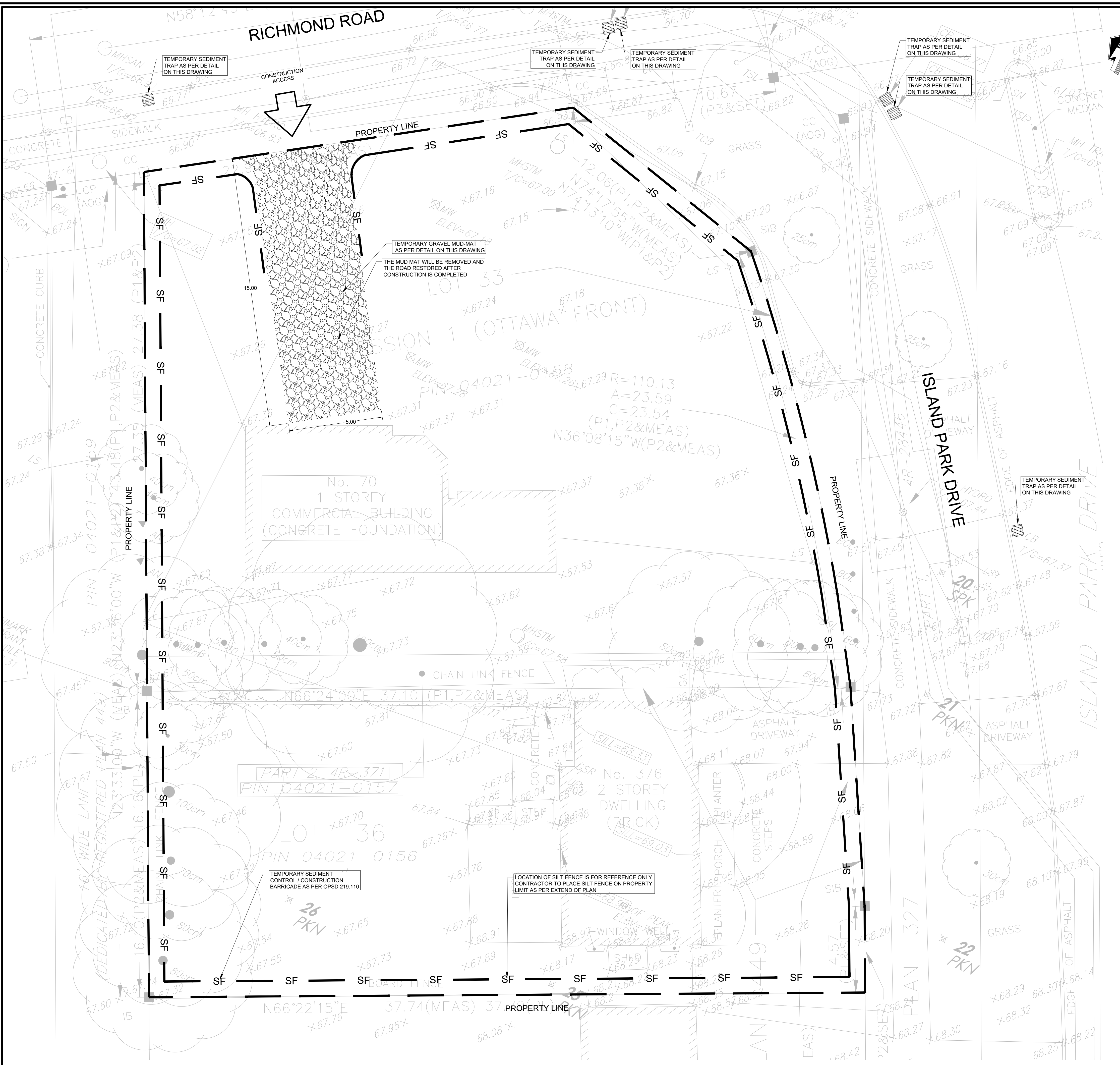

© 2022 GOOGLE, MAP DATA © 2022 TELE ATLAS

**LOCATION PLAN**  
NTS

**LEGEND**

- PROPERTY LINE
- TEMPORARY SEDIMENT CONTROL FENCE
- TEMPORARY CONSTRUCTION ACCESS
- TEMPORARY SEDIMENT TRAP
- TEMPORARY GRAVEL MUD MAT

**LIST OF DRAWINGS**

- SG-01 (SITE GRADING PLAN)
- SS-01 (SITE SERVICING PLAN)
- EC-01 (EROSION CONTROL PLAN)
- DD-01 (DETAIL DRAWINGS)

**SITE PLAN INFORMATION**  
 HOBIN ARCHITECTURE INC.  
 83 PAMILLA STREET OTTAWA, ONTARIO,  
 CANADA K1S 3K7  
 PHONE: (613) 238-7200  
 EMAIL: mail@hobinarc.com

**SURVEY INFORMATION**  
 STANTEC GEOMATICS LTD.  
 400-1331 CLYDE AVENUE  
 OTTAWA ON  
 PHONE: (613) 722-4420  
 www.stantec.com

**BENCHMARK**  
 ELEVATIONS SHOWN HEREON ARE GEODETIC (CGVD-1928:1978) AND ARE DERIVED FROM THE CAN-NET VRS NETWORK MONUMENT "OTTAWA ELEVATION-95.230."

NO	REVISION	DATE	BY
1	ISSUED FOR SITE PLAN APPLICATION	MAY 13, 2022	NM



CITY OF OTTAWA  
**EROSION CONTROL PLAN**  
 MIXED-USE DEVELOPMENT  
 70 RICHMOND ROAD  
 OTTAWA, ONTARIO  
 DEVTRIN (ISLAND PARK) INC.

**Lithos**  
 150 Bermondsey Road, Toronto, Ontario M4A 1Y1

DESIGNED BY: DS    DATE: FEBRUARY, 2016    CHECKED BY: NM  
 SCALE: 1:100    PROJECT No:    APPROVED BY: NM  
 © COPYRIGHT 2022 Lithos Group Ltd    UD18-028    EC-01

**GRADING NOTES:**

1. ALL TOPSOIL, ORGANIC OR DELETERIOUS MATERIAL MUST BE ENTIRELY REMOVED FROM BENEATH THE PROPOSED PAVED AREAS AS DIRECTED BY THE SITE ENGINEER OR GEOTECHNICAL ENGINEER.
2. EXPOSED SUBGRADES IN PROPOSED PAVED AREAS SHOULD BE PROOF ROLLED WITH A LARGE STEEL DRUM ROLLER AND INSPECTED BY THE GEOTECHNICAL ENGINEER PRIOR TO THE PLACEMENT OF GRANULARS.
3. ANY SOFT AREAS EVIDENT FROM THE PROOF ROLLING SHOULD BE SUB-EXCAVATED AND REPLACED WITH SUITABLE MATERIAL THAT IS FROST COMPATIBLE WITH THE EXISTING SOILS AS RECOMMENDED BY THE GEOTECHNICAL ENGINEER.
4. THE GRANULAR BASE SHOULD BE COMPACTED TO AT LEAST 100% OF THE STANDARD PROCTOR MAXIMUM DRY DENSITY VALUE. ANY ADDITIONAL GRANULAR FILL USED BELOW THE PROPOSED PAVEMENT SHOULD BE COMPACTED TO AT LEAST 95% OF THE STANDARD PROCTOR MAXIMUM DRY DENSITY VALUE.
5. MINIMUM OF 2% GRADE FOR ALL GRASS AREAS UNLESS OTHERWISE NOTED.
6. MAXIMUM TERRACING GRADE TO BE 3:1 UNLESS OTHERWISE NOTED.
7. ALL GRADES BY CURBS ARE EDGE OF PAVEMENT GRADES UNLESS OTHERWISE INDICATED.
8. ALL CURBS SHALL BE BARRIER CURB (150mm) UNLESS OTHERWISE NOTED AND CONSTRUCTED AS PER CITY OF OTTAWA STANDARDS (SC1.1).
9. REFER TO LANDSCAPE PLAN FOR PLANTING AND OTHER LANDSCAPE FEATURE DETAILS.
10. CONTRACTOR TO PROVIDE THE CONSULTANT WITH A GRADING PLAN INDICATING AS-BUILT ELEVATIONS OF ALL DESIGN GRADES SHOWN ON THIS PLAN.

**EROSION AND SEDIMENT CONTROL NOTES:**

1. THE CONTRACTOR SHALL IMPLEMENT BEST MANAGEMENT PRACTICES, TO PROVIDE FOR PROTECTION OF THE AREA DRAINAGE SYSTEM AND THE RECEIVING WATERCOURSE, DURING CONSTRUCTION ACTIVITIES THIS INCLUDES LIMITING THE AMOUNT OF EXPOSED SOIL, USING FILTER CLOTH UNDER THE GRATES OF CATCH BASINS AND MANHOLES AND INSTALLING SILT FENCES AND OTHER SEDIMENT TRAPS.
2. AT THE DISCRETION OF THE PROJECT MANAGER OR MUNICIPAL STAFF, ADDITIONAL SILT CONTROL DEVICES SHALL BE INSTALLED AT DESIGNATED LOCATIONS.
3. FOR SILT FENCE BARRIER USE OPSD 219.110. GEOTEXTILE FOR SILT FENCE SHALL BE ACCORDING TO OPSS 1860, TABLE 3.
4. EXCEPT AS PROVIDED IN PARAGRAPHS 4.(a), and (b) BELOW, STABILIZATION MEASURES SHALL BE INITIATED AS SOON AS FEASIBLE IN PORTIONS OF THE SITE WHERE CONSTRUCTION ACTIVITIES HAVE TEMPORARILY OR PERMANENTLY CEASED, BUT IN NO CASE MORE THAN 21 DAYS AFTER THE CONSTRUCTION ACTIVITY HAS TEMPORARILY OR PERMANENTLY CEASED.
  - 4.1. WHERE THE INITIATION OF STABILIZATION MEASURES BY THE 14TH DAY AFTER CONSTRUCTION ACTIVITY TEMPORARILY OR PERMANENTLY CEASES IS PRECLUDED BY SNOW COVER, STABILIZATION MEASURES SHALL BE INITIATED AS SOON AS FEASIBLE.
  - 4.2. WHERE CONSTRUCTION ACTIVITY WILL RESUME ON A PORTION OF THE SITE WITHIN 21 DAYS FROM WHEN ACTIVITIES CEASED, (E.G. THE TOTAL TIME PERIOD THAT CONSTRUCTION ACTIVITY IS TEMPORARILY CEASED IS LESS THAN 21 DAYS) THEN STABILIZATION MEASURES DO NOT HAVE TO BE INITIATED ON THAT PORTION OF SITE BY THE 14TH DAY AFTER CONSTRUCTION ACTIVITY TEMPORARILY CEASED.
5. SEDIMENT THAT IS ACCUMULATED BY THE TEMPORARY EROSION AND SEDIMENT CONTROL MEASURES SHALL BE REMOVED IN A MANNER THAT AVOIDS ESCAPE OF THE SEDIMENT TO THE DOWNSTREAM SIDE OF THE CONTROL MEASURE AND AVOIDS DAMAGE TO THE CONTROL MEASURE. SEDIMENT SHALL BE REMOVED TO THE LEVEL OF THE GRADE EXISTING AT THE TIME THE CONTROL MEASURE WAS CONSTRUCTED AND BE ACCORDING TO THE FOLLOWING:
  - 5.1. FOR LIGHT DUTY SEDIMENT BARRIERS ACCUMULATED SEDIMENT SHALL BE REMOVED ONCE IT REACHES THE LESSER OF THE FOLLOWING:
    - 5.1.1. A DEPTH OF ONE HALF THE EFFECTIVE HEIGHT OF THE CONTROL MEASURE.
    - 5.1.2. A DEPTH OF 300 MM IMMEDIATELY UPSTREAM OF THE CONTROL MEASURE.
  - 5.2. FOR ALL CONTROL MEASURES, ACCUMULATED SEDIMENT SHALL BE REMOVED AS NECESSARY TO PERFORM MAINTENANCE REPAIRS.
  - 5.3. ACCUMULATED SEDIMENT SHALL BE REMOVED IMMEDIATELY PRIOR TO THE REMOVAL OF THE CONTROL MEASURE.
  - 5.4. ACCUMULATED SEDIMENT IS TO BE REMOVED AND DISPOSED OF AS PER OPSS 190.
6. ALL TEMPORARY EROSION AND SEDIMENT CONTROL MEASURES SHALL BE MONITORED TO ENSURE THEY ARE IN EFFECTIVE WORKING ORDER. THE CONDITION OF THE CONTROL MEASURES SHALL BE MONITORED PRIOR TO ANY FORECAST STORM EVENT AND FOLLOWING A STORM EVENT.
7. DUST CONTROL MEASURES SHOULD BE CONSIDERED PRIOR TO CLEARING AND GRADING. THE USE OF WATER, CALCIUM CHLORIDE FLAKES/SOLUTION SHALL BE USED AS DUST SUPPRESSANTS AS PER OPSS 506. THIS IS TO LIMIT WIND EROSION OF SOILS WHICH MAY TRANSPORT SEDIMENTS OFFSITE, WHERE THEY MAY BE WASHED INTO THE RECEIVING WATER BY THE NEXT RAINSTORM.
8. ALL 'GREEN AREAS' TO BE TREATED WITH 1500mm TOPSOIL AND 800 AS SOON AS FEASIBLE, AS PER OPSS 180.
9. TOPSOIL TO BE STRIPPED AND STOCKPILED FOR REHABILITATION. CLEAN FILL TO BE PLACED IN FILL AREAS AND COMPACTED TP 95% STANDARD PROCTOR DENSITY.
10. ALL DISTURBED AREAS TO BE RESTORED TO ORIGINAL CONDITION OR BETTER UNLESS OTHERWISE SPECIFIED.
11. STOCKPILED MATERIAL IS TO BE STORED AWAY FROM POTENTIAL RECEIVERS (E.G. STORM CATCHBASINS, MANHOLES), AND BE SURROUNDED BY EROSION CONTROL MEASURES WHERE MATERIAL IS TO BE LEFT IN PLACE IN EXCESS OF 14 DAYS.
12. IF REQUIRED, DEWATERING/SETTLING BASINS SHALL BE CONSTRUCTED AS PER OPSD 219.240 AND LOCATED ON FLAT GRADE UPSTREAM OF OTHER EXISTING MITIGATION MEASURES. WATERCOURSES CROSSINGS SHALL NOT BE CONSTRUCTED OR UTILIZED, UNLESS OTHERWISE SPECIFIED IN THE CONTRACT. IF CLOSURE OF ANY PERMANENT WATER PASSAGE IS NECESSARY, THE CONTRACTOR SHALL RELEASE ANY STRANDED FISH TO THE OPEN PORTION OF THE WATERCOURSE WITHOUT HARM.
13. ALL EROSION AND SEDIMENT CONTROL MEASURES SHALL CONFORM TO OPSS 577.
14. WHERE DEWATERING IS REQUIRED, THE DISCHARGED WATER SHALL BE CONTROLLED IN ACCORDANCE WITH OPSS 518.
15. ALL SETTLING/FILTRATION BASINS SHALL BE EQUIPPED WITH TERRAFIX 270R GEOTEXTILE (OR APPROVED EQUIVALENT) AND SHALL BE CLEANED AND REPLACED AS REQUIRED.
  16. FOR POTENTIAL SPILLS, THE CONTRACTOR SHALL HAVE ON SITE AT ALL TIMES AN EMERGENCY SPILL KIT THAT WILL INCLUDE AS A MINIMUM THE FOLLOWING ITEMS:
    - 10 -18 in. x 18 in ABSORBENT PADS,
    - 5 LBS ZORBAL ABSORBING MATERIAL,
    - 1 PAIR GOGGLES, 1 PAIR PVC GLOVES.

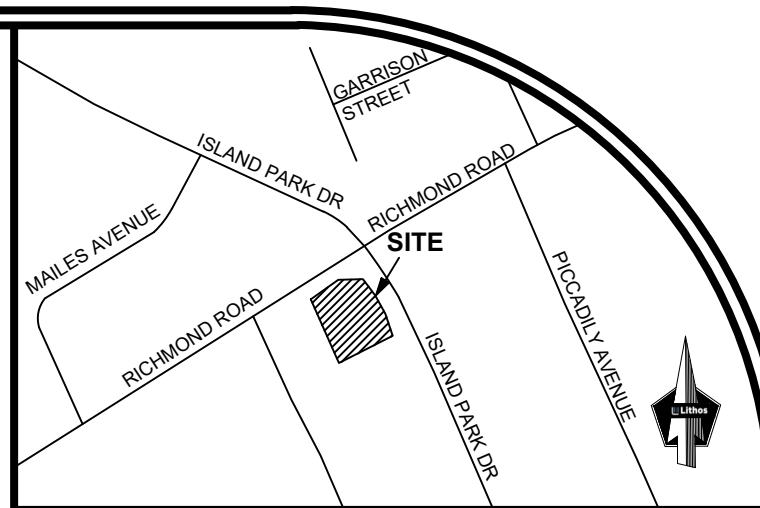

© 2022 GOOGLE, MAP DATA © 2022 TELE ATLAS  
**LOCATION PLAN**  
NTS

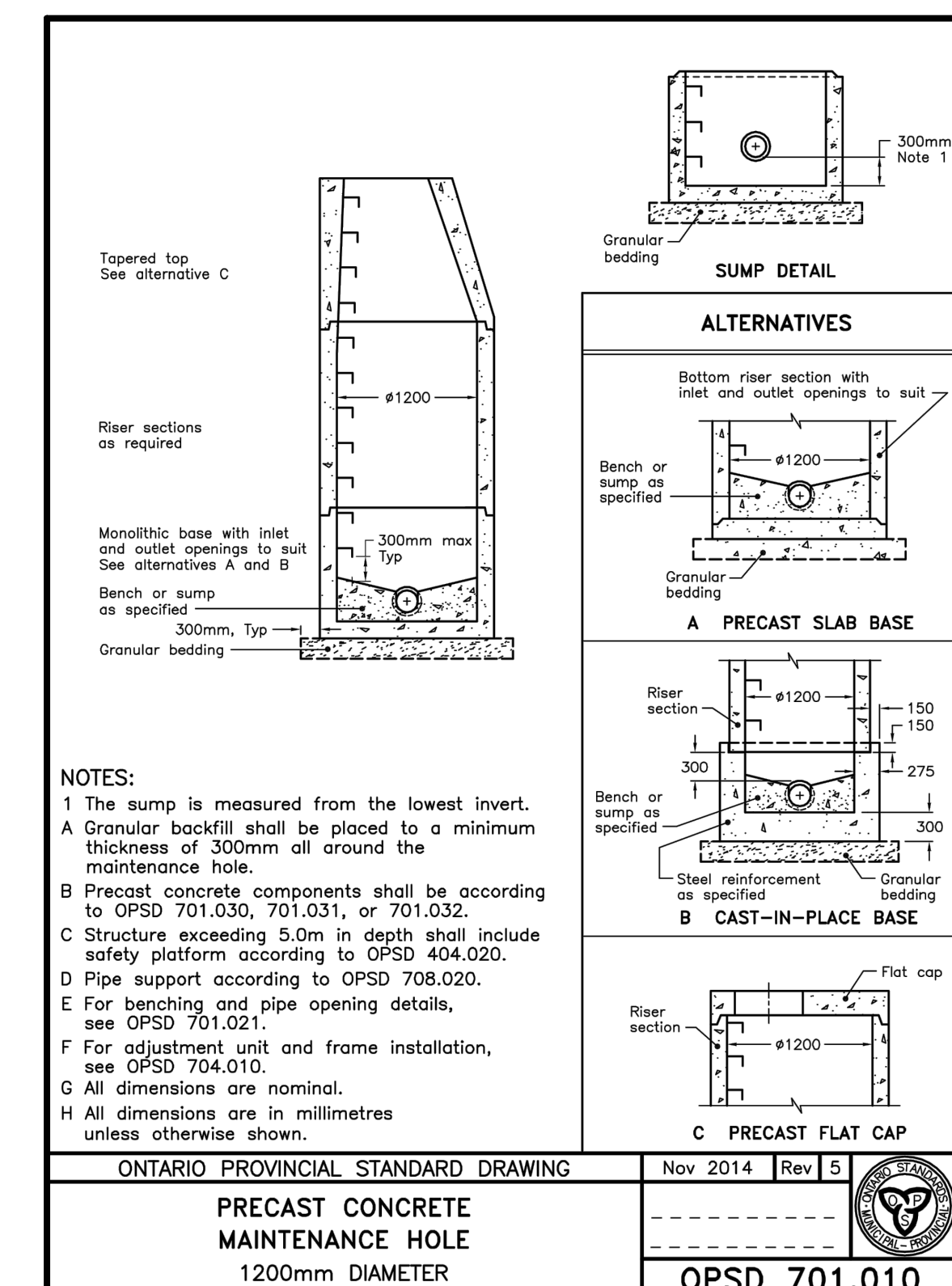
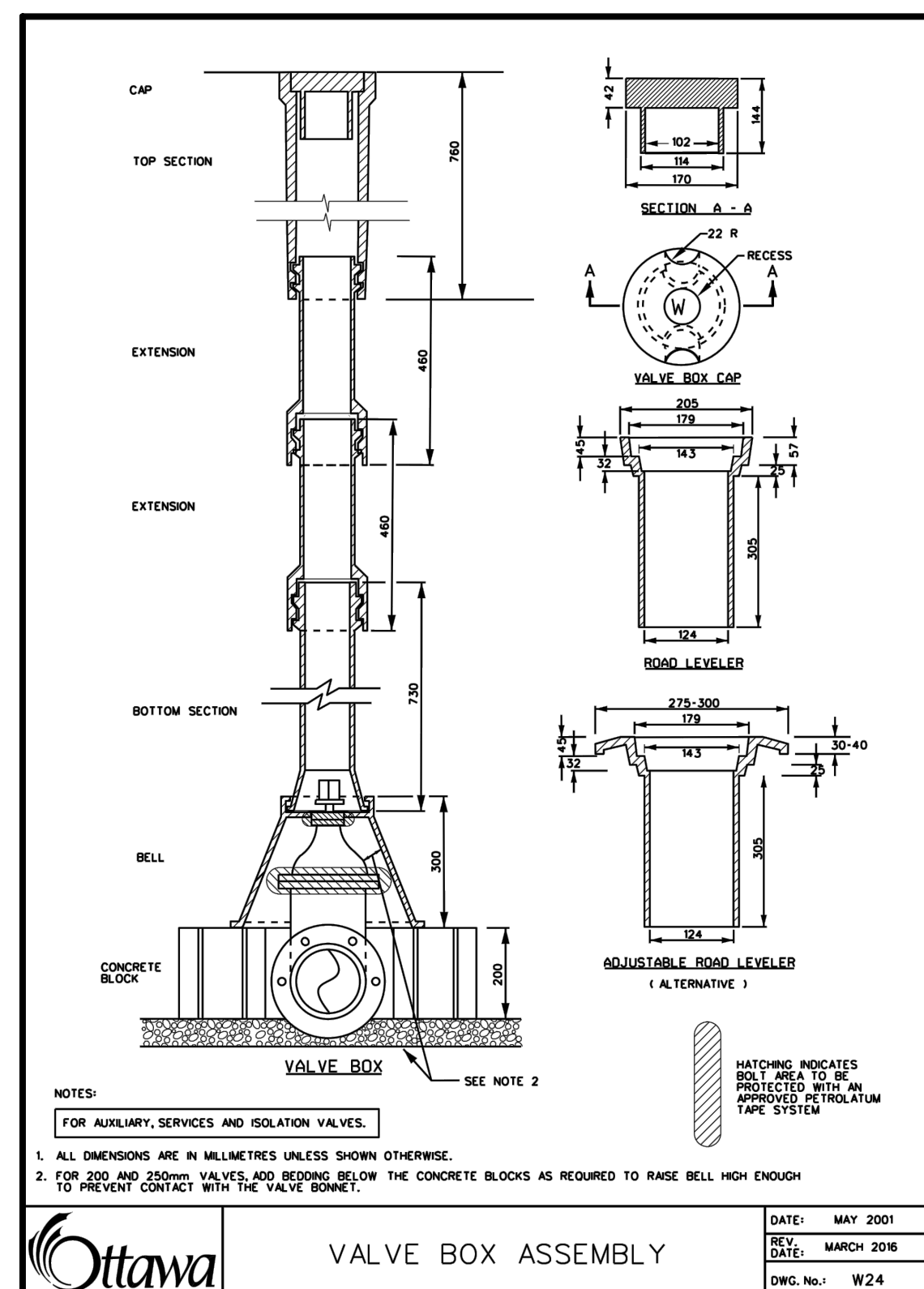
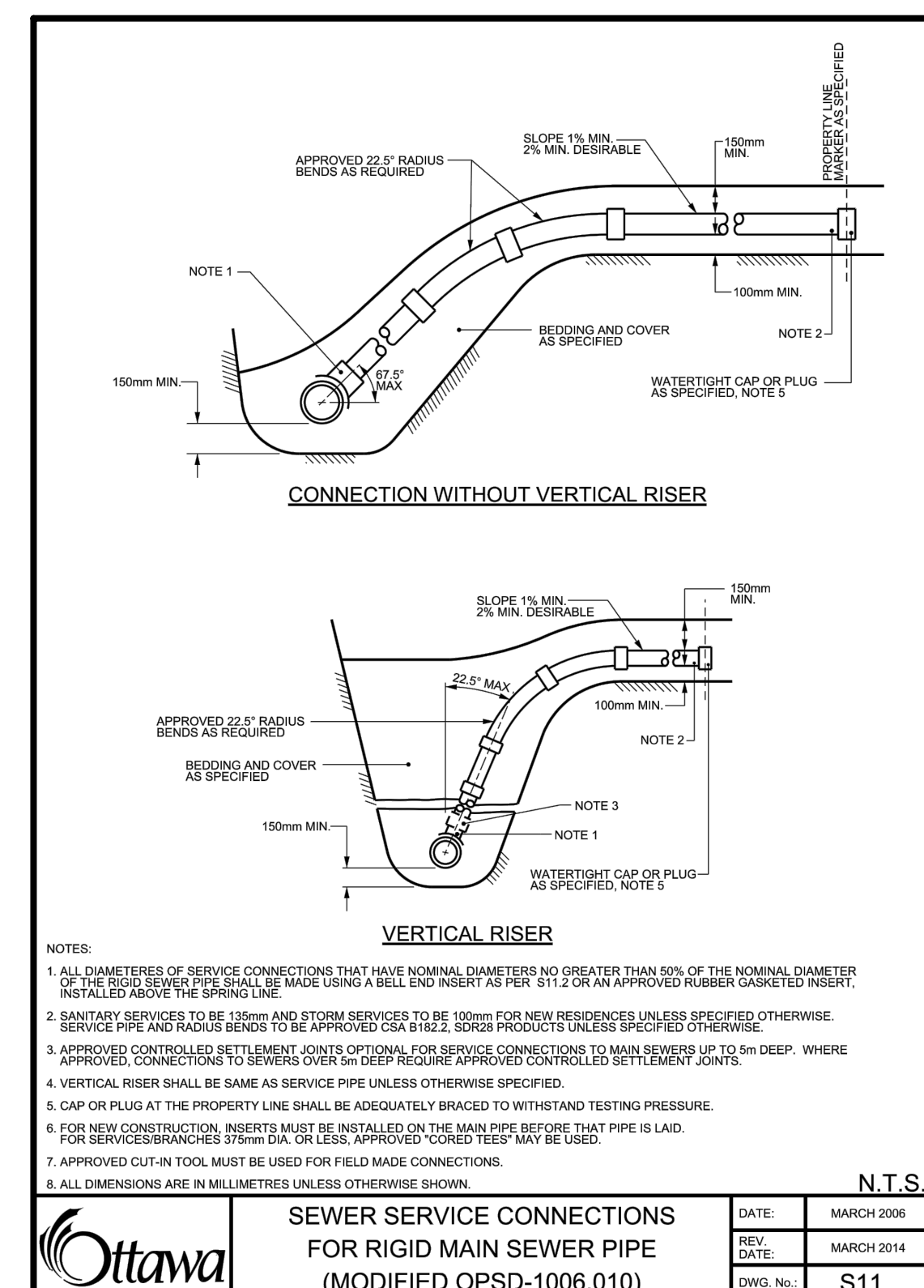
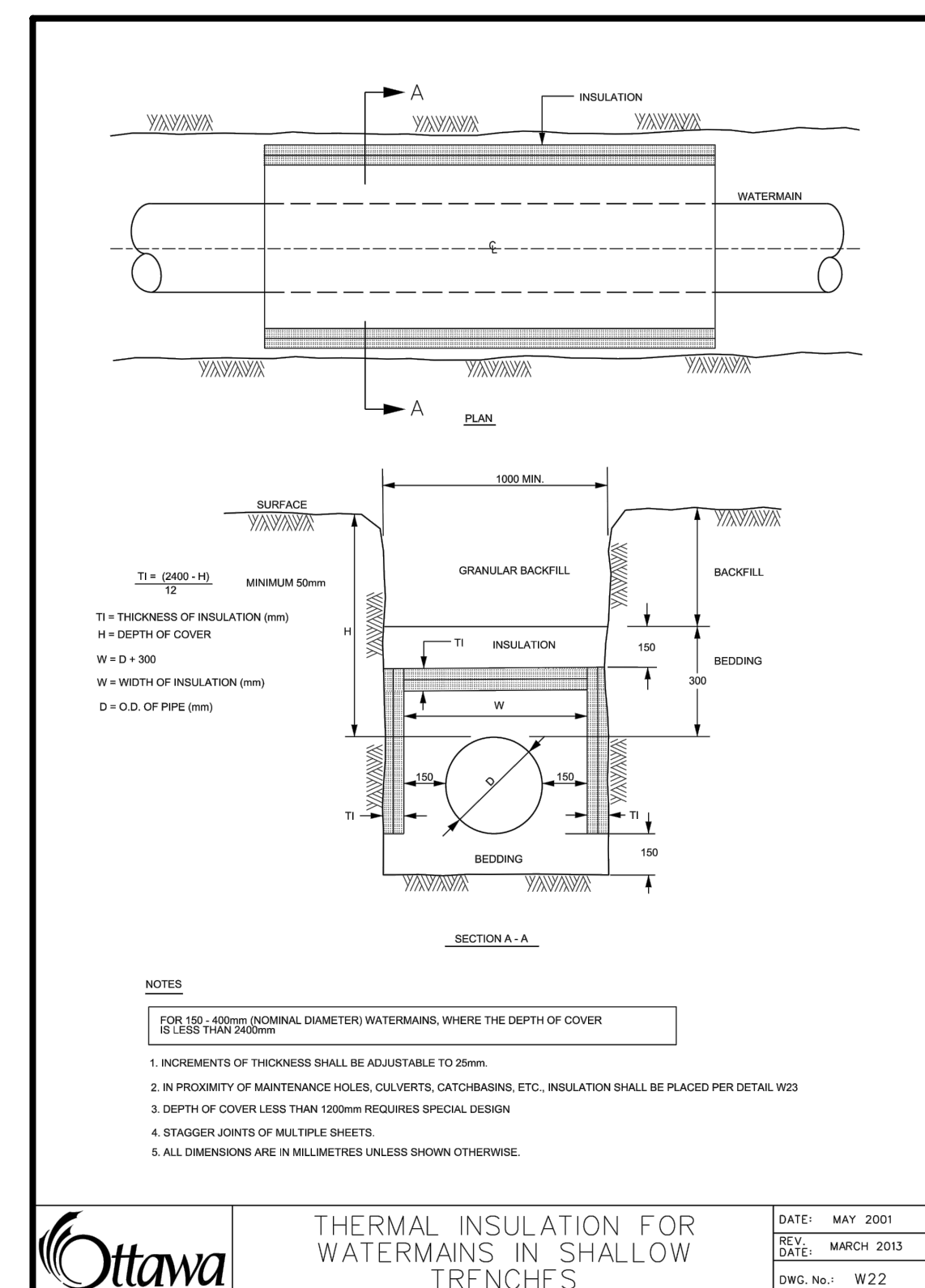
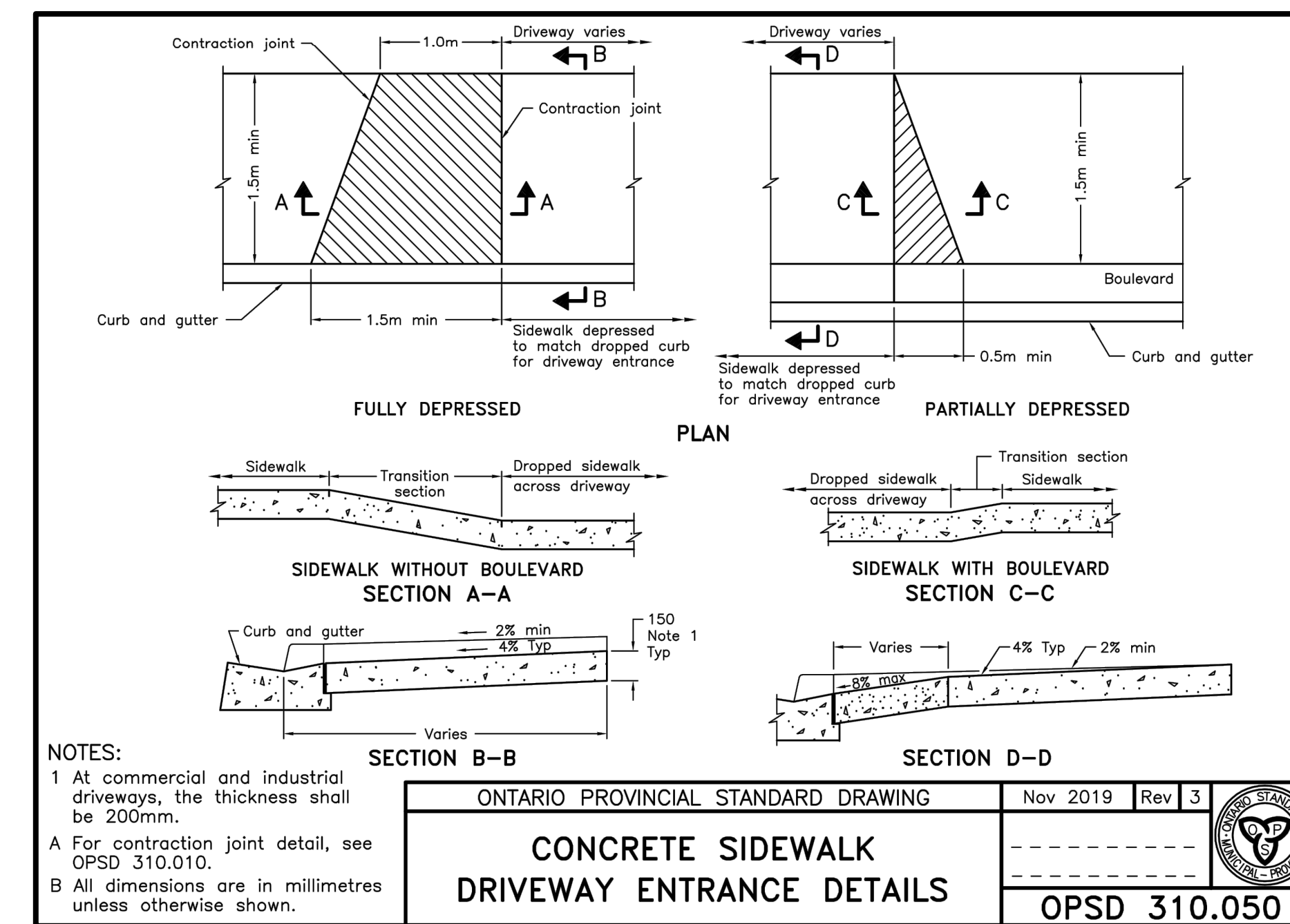

**LIST OF DRAWINGS**

- SG-01 (SITE GRADING PLAN)
- SS-01 (SITE SERVING PLAN)
- EC-01 (EROSION CONTROL PLAN)
- DD-01 (DETAIL DRAWINGS)

**SITE PLAN INFORMATION**

HOBIN ARCHITECTURE INC.  
63 PAMILLA STREET, OTTAWA, ONTARIO,  
CANADA K1S 3K7  
PHONE: (613) 238-7200  
EMAIL: mail@hobinarc.com

**SURVEY INFORMATION**

STANTEC GEOMATICS LTD.  
400-1331 CLYDE AVENUE  
OTTAWA ON  
PHONE: (613) 722-4420  
www.stantec.com

**BENCHMARK**

ELEVATIONS SHOWN HEREON ARE GEODETIC (CGVD-1928-1978) AND ARE DERIVED FROM THE CAN-NET VRS NETWORK MONUMENT OTTAWA ELEVATION=95.230.

NO	REVISION	DATE	BY
1.	ISSUED FOR SITE PLAN APPLICATION	MAY 13, 2022	NM

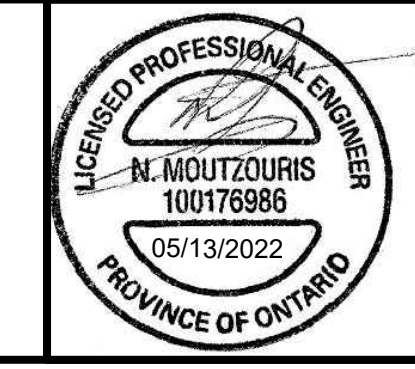

CITY OF OTTAWA

**DRAWING DETAILS**

MIXED USE DEVELOPMENT  
70 RICHMOND ROAD  
OTTAWA, ONTARIO  
DEVTRIN (ISLAND PARK) INC.



150 Bermondsey Road, Toronto, Ontario M4A 1Y1

DESIGNED BY: DS	DATE: FEBRUARY, 2016	CHECKED BY: NM
DRAWN BY: DS	PROJECT No:	APPROVED BY: NM
SCALE: NTS		DRAWING No:
© COPR/ENR/2022 Lithos Group Ltd.	UD18-028	DD-01