



## **Stormwater Management Report and Servicing Brief**

Proposed Halo Car Wash  
3535 Borrisokane Rd  
Barrhaven, Ontario

Prepared for:

Halo Car Wash Inc.  
18 Adelaide Street  
Maxville, ON  
K0C 1T0

Attention: Mr. Jordan Lupovici

LRL File No.: 210691

April 22, 2022



## TABLE OF CONTENTS

<b>1</b>	<b>INTRODUCTION AND SITE DESCRIPTION</b> .....	<b>1</b>
<b>2</b>	<b>EXISTING SITE AND DRAINAGE DESCRIPTION</b> .....	<b>2</b>
<b>3</b>	<b>SCOPE OF WORK</b> .....	<b>2</b>
<b>4</b>	<b>REGULATORY APPROVALS</b> .....	<b>3</b>
<b>5</b>	<b>WATER SUPPLY AND FIRE PROTECTION</b> .....	<b>3</b>
5.1	Existing Water Supply Services.....	3
5.2	Water Supply Servicing Design .....	3
<b>6</b>	<b>SANITARY SERVICE</b> .....	<b>5</b>
6.1	Existing Sanitary Sewer Services.....	5
6.2	Sanitary Sewer Servicing Design .....	5
<b>7</b>	<b>STORMWATER MANAGEMENT</b> .....	<b>6</b>
7.1	Existing Stormwater Infrastructure .....	6
7.2	Design Criteria .....	6
7.2.1	Water Quality.....	6
7.2.2	Water Quantity .....	7
7.3	Method of Analysis .....	7
7.4	Proposed Stormwater Quantity Controls.....	7
<b>8</b>	<b>EROSION AND SEDIMENT CONTROL</b> .....	<b>9</b>
<b>9</b>	<b>CONCLUSION</b> .....	<b>9</b>
<b>10</b>	<b>REPORT CONDITIONS AND LIMITATIONS</b> .....	<b>10</b>



## APPENDICES

- Appendix A Pre-consultation / Correspondence
- Appendix B Water Supply Calculations
- Appendix C Wastewater Calculations
- Appendix D Stormwater Management Calculations
- Appendix E Civil Engineering Drawings
- Appendix F Survey, As-Built Drawings

## LIST OF TABLES

Table 1: City of Ottawa Water Servicing Design Parameters.....	4
Table 2: City of Ottawa Wastewater Design Parameters.....	5
Table 3: Drainage Areas and Runoff Coefficients.....	8
Table 4: Summary of Proposed Development Stormwater Release Rates.....	8

## LIST OF FIGURES

Figure 1 – Aerial View of Proposed Development.....	1
---	---



## 1 INTRODUCTION AND SITE DESCRIPTION

LRL Associates Ltd. was retained by Halo Car Wash Inc. to complete a Stormwater Management Analysis and Servicing Brief for the construction of a car-wash development located at 3535 Borriskane Rd, Barrhaven, Ontario. The property is legally described as Part of Lot 11, Concession 3 (Rideau Front), geographic Township of Nepean and Zoning IL – Light Industrial. The location of the proposed development can be viewed in Figure 1.



**Figure 1: Aerial View of Proposed Development**

The development proposes construction of a Halo Tunnel Car Wash (485 sqm). The site will be accessible from a 7.5 m wide entrance located off Flagstaff Drive. This entrance will be a shared ROW once the development to the south is to be developed. For additional details of the proposed development, refer to Site Plan C201 included in Appendix E.

This report has been prepared in consideration of the terms and conditions noted above and with the civil drawings prepared for the proposed new development. Should there be any changes in the design features, which may relate to the stormwater management and servicing considerations, LRL Associates Ltd. should be advised to review the report recommendations.

## **2 EXISTING SITE AND DRAINAGE DESCRIPTION**

The subject site measures approximately 0.534 ha and is currently undeveloped, consisting of grassed area and treed area. Elevations of existing site range between 93.01 near the northeast corner to 92.23 at the southwest corner of the site.

Sewer and watermain locations were adopted from the current subdivision design produced by DSEL Engineering. It indicates the following infrastructures located within the adjacent right-of-way:

### **Flagstaff Drive**

- 200 mm diameter PVC watermain stub
- 200 mm diameter PVC sanitary sewer

### **Borrisokane Rd**

- Roadside ditches

The design intentions are to continue the water and sanitary services that were provided through this subject property and stub them past the proposed curb for future development to the south. This development will be connected to those services, and the storm outlet will be directed to the Borrisokane roadside ditch.

## **3 SCOPE OF WORK**

As per applicable guidelines, the scope of work includes the following:

### **Stormwater management**

- Calculate the allowable stormwater release rate.
- Calculate the anticipated post-development stormwater release rates.
- Demonstrate how the target quantity control objectives will be achieved.
- Demonstrate how the target quality control objectives will be achieved.

### **Water services**

- Calculate the expected water supply demand at average and peak conditions.
- Calculate the required fire flow as per the Fire Underwriters Survey (FUS) method.
- Confirm the adequacy of water supply and pressure during peak flow and fire flow.
- Describe the proposed water distribution network and connection to the existing system.



## **Sanitary services**

- Describe the existing sanitary sewers available to receive wastewater from the proposed development.
- Calculate peak flow rates from the proposed development.
- Describe the proposed sanitary sewer system.

## **4 REGULATORY APPROVALS**

An MECP Environmental Compliance Approval (ECA) is expected to be required for installation of the proposed storm and sanitary sewers within the site. A Permit to Take Water is not anticipated to be required for pumping requirements for sewer installation. The Rideau Valley Conservation Authority (RVCA) will need to be consulted in order to obtain municipal approval for site development. No other approval requirements from other regulatory agencies are anticipated.

## **5 WATER SUPPLY AND FIRE PROTECTION**

### **5.1 Existing Water Supply Services**

The subject property is located to the south of a proposed 300 mm dia. watermain along Flagstaff Drive. A 200 mm dia. water service stub is available near the northeast corner of the property for service connection.

### **5.2 Water Supply Servicing Design**

The subject property is proposed to be serviced via a 100 mm dia. water servicing to be connected to the 200 mm dia. watermain stub located within Flagstaff Drive at the northeast corner of the site. For servicing layout, refer to Site Servicing Plan C401 in Appendix E.

Table 1 summarizes the City of Ottawa Design Guidelines design parameters employed in the preparation of the water demand estimate.



**Table 1: City of Ottawa Water Servicing Design Parameters**

<b>Design Parameters</b>	<b>Value</b>
Average Day Demand - Commercial	28,000 L/gross ha/day
Average Day Demand - Light Industrial	35,000 L/gross ha/day
Maximum Day Demand-Commercial/Industrial	1.5 × Average Day Demand
Maximum Hour Demand-Commercial/Industrial	1.8 × Maximum Day Demand
Minimum Depth of Cover	2.4 m from top of watermain to finished grade
Desired operating pressure during Maximum Day Flow	345 kPa (50 psi) to 552 kPa (80 psi)
Minimum allowable pressure during Peak Hour Flow	275 kPa (40 psi)
Minimum allowable pressure during Fire Flow Conditions	140 kPa (20 psi)

The required water supply requirements for the proposed development is calculated by using the parameters in Table 1 are included in Appendix B. Below is the summary of anticipated water demands

- Average Day Demand = 1.29 L/s
- Maximum Day Demand = 2.29 L/s
- Peak Hour Demand = 6.72 L/s

Based on the review Hydraulic Capacity and Modelling Analysis (dated May 31, 2021) provided by DSEL, it appears that adequate pressure is available in proximity to the site to service the proposed development. Overall, the pressure scenarios at the proposed connection meet the required pressure range stated in Table 1 except for minimum hour demand (MHD) conditions when the maximum pressure reaches 93 psi (Figure E.1). The maximum pressure at the service entry is anticipated to be more than 80 psi, therefore, a pressure check at the completion of construction is required to determine if a pressure reducing valve (PRV) is required as the residual pressure is not to exceed 80 psi. Refer to Appendix B for the selected modeling analysis results.



The estimated fire flow for the proposed buildings was determined in accordance with Fire Underwriters Survey (FUS) using the formula:

$$F = 220C\sqrt{A}$$

where,

F = The required fire flow (L/min)

C = Coefficient related to the type of construction

A = The total floor area (m<sup>2</sup>)

The estimated fire flow demand is calculated 3900 L/min, see Appendix B for calculation details. The fire hydrants in proximity to the site along Flagstaff Dr is expected to provide required fire flow for the subject site. Refer to Servicing Plan C401 for the location of available fire hydrants.

## 6 SANITARY SERVICE

### 6.1 Existing Sanitary Sewer Services

There is an existing 200 mm dia. sanitary sewer service stub extending to the property line from Flagstaff Drive at the northeast corner of the subject site.

### 6.2 Sanitary Sewer Servicing Design

As previously stated, the sanitary sewer will be extended along the south extent of the property and stubbed at the proposed curb. The proposed development will be serviced via 150 mm dia. sanitary sewers which will be connected to the proposed 200mm dia. sanitary sewer extending to the subject site. Refer to LRL drawing C401 for the proposed sanitary servicing layout. Table 2 summarizes the City of Ottawa Design Guidelines design parameters used in the estimation of wastewater flow.

**Table 2: City of Ottawa Wastewater Design Parameters**

Design Parameters	Value
Commercial Average Flow	28,000 L/gross ha/day
Average Light Industrial Flow	35,000 L/gross ha/day





Commercial Peak Factor	1.5
Industrial Peak Factor	Appendix 4-B (City Guidelines-Sewer)
Infiltration Allowance (Dry Weather)	0.05 L/s/gross ha
Infiltration Allowance (Wet Weather)	0.28 L/s/gross ha
Total Infiltration Allowance	0.33 L/s/gross ha

Based on these parameters, City of Ottawa’s Appendix 4-A (Daily Sewage Flow for Various Types of Establishments), and the car wash information as per Halo Car Wash, the anticipated post-development peak design wastewater flow for the subject site is calculated 6.32 L/s. Refer to Appendix C for calculation details and the sewer design sheet.

## 7 STORMWATER MANAGEMENT

### 7.1 Existing Stormwater Infrastructure

There is an existing roadside ditch on Borrisokane Rd at the west extent of the site.

In pre-development conditions, the stormwater runoff would flow uncontrolled overland to the existing ditch. Refer to Appendix D for pre- and post-development watershed information.

### 7.2 Design Criteria

The stormwater management criteria for this development is based on pre-consultation meeting with the City of Ottawa officials, the City of Ottawa Sewer Design Guidelines, 2012 (City standards), as well as the Ministry of the Environment’s Stormwater Management, Planning and Design Manual, 2003.

#### 7.2.1 Water Quality

Based on site plan pre-consultation meeting note and correspondence with Rideau Valley Conservation Authority (RVCA), it was advised to achieve enhanced water quality protection (80% TSS removal) either through on-site or downstream infrastructure prior to discharging stormwater to a natural watercourse.

To address water quality objective, an Oil/Grit Separator (OGS), Stormceptor EFO4 (or approved equivalent) is proposed downstream of CBMH10 which will exceeds the required 80% TSS



removal. Refer to Appendix D for additional details on proposed OGS and servicing plan C401 (Appendix E) for the location of OGS.

### **7.2.2 Water Quantity**

The allowable release rate for the subject site has been calculated to 5-yr pre-development level and was determined 30.95 L/s. Post-development storm events up to and including 100-yr storm will be controlled to 5-yr pre-development level. For calculations, refer to STM design calculation sheets in Appendix D.

### **7.3 Method of Analysis**

The modified Rational Method has been used to calculate the peak flow rate from the proposed site and to quantify the storage required for quantity control for the proposed development.

$$Q = 2.78CIA$$

Where,

Q = Flow (L/s)

C = Runoff Coefficient

I = Rainfall Intensity (mm/hr), determined from the City of Ottawa IDF curves

A = Area (ha)

Refer to Appendix D for runoff and storage calculations.

### **7.4 Proposed Stormwater Quantity Controls**

The proposed stormwater management quantity control for this development will be accomplished using an Inlet Control Device (ICD) in the storm sewer. Ponding required as a result of quantity control will be accomplished through surface storage in the parking lot.

A network of storm sewers is proposed to service the site and outlet to the existing ditch along Borrisokane Rd which will eventually outlet to the existing 800mm dia. culvert crossing Borrisokane Rd. The proposed site storm sewers and stormwater management system are shown on Site Servicing Plan C401 and detailed calculations including the design sheet can be found in Appendix D.



The existing site is delineated by catchments EWS-01 which currently drains un-controlled towards the west existing ditch. Refer to Pre-development Watershed Plan C701 included in Appendix E. The site has been analyzed and post-development watersheds have been allocated. A few watersheds WS-08 and WS-09 consisting of grass area and asphalt area will flow un-controlled off the site. For additional details, refer to Post-development Watershed Plan C702 included in Appendix E.

Overland flow in Halo Car Wash area within watersheds WS-01, WS-02, WS-03, WS-04, WS-05, WS-06 & WS-07 will be captured by a several CB/CBMHs. An ICD, Hydrovex Vortex Flow Regulator 125VHV-2 or approved equivalent, is proposed at CBMH10 to restrict the collected runoff and control the release rate at 21.74 L/s. For additional details on select ICD, refer to Appendix D. Table 3 summarizes post-development drainage areas. Additional details and calculations can be found in Appendix D.

**Table 3: Drainage Areas and Runoff Coefficients**

Site	Watersheds	Area (ha)	Weighted Runoff Coefficient
Halo Car Wash	WS-01 (controlled)	0.064	0.41
	WS-02 (controlled)	0.056	0.85
	WS-03 (controlled)	0.096	0.68
	WS-04 (controlled)	0.056	0.90
	WS-05 (controlled)	0.115	0.90
	WS-06 (controlled)	0.032	0.68
	WS-07 (controlled)	0.046	0.46
	WS-08 (uncontrolled)	0.027	0.20
	WS-09 (uncontrolled)	0.042	0.22
	<b>Total</b>	<b>0.534</b>	<b>0.66</b>

Table 4 summarizes the release rates, storage volume required and available storage in the proposed site.

**Table 4: Summary of Proposed Development Stormwater Release Rates**

Watersheds	Area (ha)	Release Rate (L/s)		Storage Required (m <sup>3</sup> )		Storage Provided (m <sup>3</sup> )
		100-yr	5-yr	100-yr	5-yr	
Controlled (WS-01 to WS-07)	0.465	21.74	21.74	158.73	74.07	213.39
Uncontrolled (WS-08 to WS-09)	0.069	9.21	4.30	N/A	N/A	N/A
<b>Total</b>	<b>0.534</b>	<b>30.95</b>	<b>26.04</b>	<b>158.73</b>	<b>74.07</b>	<b>213.39</b>



The runoff exceeding the allowable release rate will be stored on-site via surficial ponding. For 100-yr storm event, it is calculated that a total of 158.73 m<sup>3</sup> of storage will be required to attenuate flows to the allowable release rate of 21.74 L/s (controlled release). The total storage provided is 213.39 m<sup>3</sup>, thus exceeds the required storage. Refer to Appendix D for details on runoff and storage calculations. The maximum ponding elevation and depths can be found on Stormwater Management Plan C601 in Appendix E.

## 8 EROSION AND SEDIMENT CONTROL

During construction, erosion and sediment controls will be provided primarily via a sediment control fence to be erected along the perimeter of the site where runoff has the potential of leaving the site. Inlet sediment control devices are also to be provided in any catch basin and/or manholes in and around the site that may be impacted by the site construction. Construction and maintenance requirements for erosion and sediment controls are to comply with Ontario Provincial Standard Specification OPSS 577. Refer to Erosion and Sediment Control Plan C101 for additional details.

## 9 CONCLUSION

This Stormwater Management and Servicing Report for the proposed development at 3535 Borrisokane Rd presents the rationale and details for the servicing requirements for the subject property. In accordance with the report objectives, the servicing requirements for the development are summarized below.

### Water Service

- The anticipated maximum hour demand of the proposed development is 6.72 L/s.
- The maximum required fire flow is 65.00 L/, calculated using the FUS method.
- The fire hydrant on Flagstaff Dr will service the proposed development.
- The proposed development will be serviced with a new 100 mm dia. watermain to be connected to the proposed 200 mm dia. watermain stub which will be connected to a watermain along Flagstaff Dr.
- Modeling results provided by DSEL show that adequate pressure is available in the proposed water distribution network to service the proposed site.



## Sanitary Service

- The anticipated sanitary flow from the proposed development is 6.32 L/s.
- The proposed development will be serviced by a network of 150 mm dia. sanitary sewers which will connect to the prop SAN MH69.

## Stormwater Management

- Stormwater quality control requirements of 80% TSS removal will be met via the use of an Oil/Grit Separator (Stormceptor model EFO4 or approved equivalent).
- The storm water release rates from the proposed development will meet contemplated allowable release rate of 30.95 L/s (21.74 L/s controlled and 9.21 L/s uncontrolled).
- Stormwater quantity control objectives will be met through on-site stormwater surface storage in the parking lots.

## 10 REPORT CONDITIONS AND LIMITATIONS

The report conclusions are applicable only to this specific project described in the preceding pages. Any changes, modifications or additions will require a subsequent review by LRL Associates Ltd. to ensure the compatibility with the recommendations contained in this document.

If you have any questions or comments, please contact the undersigned.

Prepared by:

**LRL Associates Ltd.**



Maxime Longtin  
*Civil Engineering Technologist*



Mohan Basnet, P.Eng.  
*Civil Engineer*



## **APPENDIX A**

**Pre-consultation / Correspondance**

**3555 Borrisokane Road**  
Meeting Summary Notes  
Sept 23, 2021. Online Teams Meeting

**Attendees:**

- Jonah Bonn (Applicant, First Bay Properties Inc.)
- Bill Holzman (Applicant, Holzman Consultants)
- Philippe Paquette (LRL Associates)
- Peter MacEwen (MacEwen)
- Brad Moore (MacEwen)
- Greg Pedersen (Halowash)
- Jordan Lupovici (Halowash)
- Katie Morphet (File Lead, Panner, City of Ottawa)
- Jeff Shillington (Project Manager, City of Ottawa)
- Neeti Paudel (Transportation Project Manager, City of Ottawa)
- Sami Rehman (Environmental, City of Ottawa)
- Jeannette Krabicka (Parks, City of Ottawa)

**Not in Attendance:**

- Mark Richardson (Forestry, City of Ottawa)
- RVCA

**Issue of Discussion:**

- Site Plan Control for a new 1-storey 480 sq. m drive-through carwash with 3 queuing lanes for 18 cars and 21 parking spaces (18 of which are vacuum accessible).
- Development to be located on northern most 1.32 acres of total vacant property.

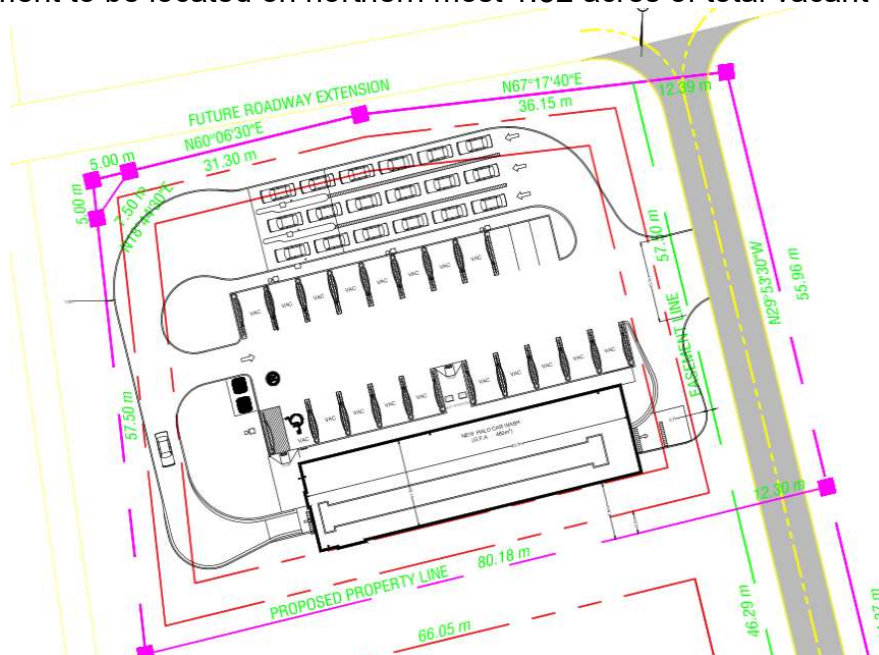

### 1. Official Plan - designated "General Urban Area".

Car wash a permitted use

Barrhaven South CDP – property identified as institutional

### 2. Zoning Information

Zoned IL [304]

Urban Exception 304 permits place of worship as an additional use.

IL Zone permits Drive-Through Facility and Car wash uses

Zoning interpretation has confirmed that Section 203 (2)(c) limits the Car wash use to 300 sq. m.

Floodplain overlay on a portion of the site – RVCA has confirmed that this floodplain area has been removed from their mapping. It will still need to be removed from the City's mapping.

Within the 400 m MTO Permit Control Area

### 3. Infrastructure/Servicing – Jeff Shillington

- Servicing for the subdivision is currently being designed by DSEL for Mattamy. To coordinate service locations please contact Jen Ailey at DSEL (email: [jailey@dssel.ca](mailto:jailey@dssel.ca), cell no. 613-222-6476)
- The current design has not yet been approved, however a 2<sup>nd</sup> submission of the detailed design is currently under review. There were no significant concerns with any of the servicing proposed for this area.
- The current design shows the following:
  - 300 mm dia. sanitary sewer along Flagstaff with a 200 mm service and control MH proposed just inside the property in the northeast corner.
  - 300 mm watermain along Flagstaff with a 200 mm service and valve on the property line in the northeast corner of the property.
  - No storm sewer is proposed along Flagstaff. Stormwater could be outlet into the ditch on Borrisokane Road. A C=0.80 for the 5 year event should be used for the design. As per RVCA requirements the stormwater must maintain enhanced water quality protection either through on-site or down stream infrastructure prior to outletting to the Jock River.



- A MECP ECA is likely required for the stormwater outlet to the Borrisokane ditch.
- As discussed at the meeting a shared servicing corridor along the private road would be possible to service the neighboring site to the south. A joint use maintenance agreement and MECP ECA for the shared sanitary sewer would be required.

#### **4. Initial Planning Comments – Katie Morphet**

- Please add table to submitted site plan to identify all required zone and applicable general provisions and that they are being met.
- I have been able to confirm that Section 203 (2)(c) does limit the proposed car wash use to 300 sq.m. If you wish to move forward with a footprint of this size a minor variance would need to be approved prior to the Site Plan being finalized and approved. I understand that the minor variance process is severely backed up due to covid so I would inquire with the Committee timing for the next available meeting.
- The floodplain overlay will need to be removed from the property prior to approval of a Site Plan.

The flood plain can be dealt with multiple ways.

1. You can undertake a site-specific ZBA;
  2. If the timing works for both the applicant and the zoning group the City can add it to the omnibus report. The next omnibus report is expected in Q1 of 2022. This means it could go forward at the end of April 2022; or
  3. It will be removed when the City undertakes flood plain mapping updates. The floodplain mapping for this area is expected to be updated by the end of the year but it is not guaranteed.
- A Survey Plan will be required to clarify property boundaries and lot ownership.
  - The Site Plan design drawings and agreement and will apply to entire lot if it is yet to be severed at the time of application.
  - The site is within 400m of the High 416 – MTO Permit control Area – please confirm with MTO whether you require a permit from them.

## 5. Parks – Jeanette Krabicka

Please see the attached comments.

## 6. Trees - Mark Richardson

- 1) if there are trees >10cm in diameter on site a tree removal permit will required and a TCR will need to be submitted with their application
- 2) they will need to contact [mark.richardson@ottawa.ca](mailto:mark.richardson@ottawa.ca) for information on the permitting and TCR process.

## 7. Environment – Sami Rehman

The subject property is located adjacent to an Urban Natural Feature (UNF) called Cambrian Woods North and the proposal requires an Environmental Impact Statement (EIS) as outlined in OP section 3.2.3 and 4.7.8. As such, the EIS will need to address:

- potential impacts from the development on the UNF
- potential impacts from the development on the adjacent watercourse
- significant habitat for threatened or endangered species
- review and draw recommendations from the Jock River Reach 1 Subwatershed Plan
- review and draw recommendations from the Protocol for Wildlife Protection during Construction

Further details on the EIS requirements can be found in OP Section 4.7.8 or the EIS guidelines:

[https://documents.ottawa.ca/sites/documents/files/documents/eis\\_guidelines2015\\_en.pdf](https://documents.ottawa.ca/sites/documents/files/documents/eis_guidelines2015_en.pdf)

City staff will be looking to ensure that the proposal's design includes buffering along the adjacent watercourse.

Staff are also recommending landscaping and design elements that will reduce energy and water consumption, as outlined in OP Section 4.9.

Given the subject property's proximity to the UNF, the adjacent watercourse and the Jock River, staff will be anticipating using only locally appropriate native species in their landscape plan.

I recommend contacting the Trail Road Waste Facility to identify their comments or advice for this proposed development because the subject property is within 500m of the facility.

I would also recommend consulting with the Rideau Valley Conservation Authority to determine if any permits or approvals are required under their regulations.

While not explicitly discussed in this meeting, a severance will trigger the requirement for an EIS and the advice provided above would be applicable to that EIS and severance application.

## 8. Conservation Authority – Eric Lalande (RVCA)

For the floodplain, mapping below shows that the floodplain does not extend onto the property. This was confirmed and updated on our end earlier this year, and mapping at the City should be updated through an omnibus zoning amendment.

As for SWM and TSS removal, you are required to maintain enhanced water quality protection either through on-site or down stream infrastructure prior to any outlet to a natural watercourse. Note that setbacks and stormwater should take into consideration the realigned channel adjacent to your site (along the easterly property boundary).

Given the use, I would also suggest you contact the City's HydroG related to any groundwater constraints given the use.

## 9. Transportation – Neeti Paudel

Follow Traffic Impact Assessment Guidelines

- Complete the screening form as soon as possible and submit it to the Neeti Paudel at [neeti.paudel@ottawa.ca](mailto:neeti.paudel@ottawa.ca) for review. Please include the **site generated trips** for the trip generation trigger. Once reviewed, and if, the triggers are met, proceed to Step 2.
- **Applicant advised that their application will not be deemed complete until the submission of the draft step 1-4, including the functional draft RMA package (if applicable) and/or monitoring report (if applicable). Collaboration and communication between development proponents and City staff are required at the end of every step in the TIA process**
- Request base mapping asap if RMA is required. Contact Engineering Services (<https://ottawa.ca/en/city-hall/planning-and-development/engineering-services>)
- Noise Impact Studies required for the following:
  - Stationary (if, within 100m of noise sensitive land use).
- Ensure clear throat length requirements as per TAC are met at the accesses.

- On site plan:
  - Show all details of the roads abutting the site up to and including the opposite curb; include such items as pavement markings, accesses and/or sidewalks.
  - Turning templates will be required for all accesses showing the largest vehicle to access the site; required for internal movements and at all access (entering and exiting and going in both directions).
  - Show all curb radii measurements; ensure that all curb radii are reduced as much as possible
  
- As the proposed site is for general public use, AODA legislation applies. Consider using the City's Accessibility Design Standards.
  
- Number of accessible parking spaces should meet the requirements from Table 3 of the City's accessible Design Standards.
  
- Site triangles at the following locations on the final plan will be required:
  - Local Road to Local Road: 3 metre x 3 metres
  - Local Road to Collector Road: 5 metre x 5 metres
  - Collector Road to Collector Road: 5 metre x 5 metres
  - Collector Road to Arterial Road: 5 metre x 5 metres

## **10. General Information**

- a. Ensure that all plans and studies are prepared as per City guidelines – as available online...  
<https://ottawa.ca/en/city-hall/planning-and-development/information-developers/development-application-review-process/development-application-submission/guide-preparing-studies-and-plans>

## Mohan Basnet

---

**From:** Eric Lalande <eric.lalande@rvca.ca>  
**Sent:** September 24, 2021 10:42 AM  
**To:** Philippe Paquette; Jamie Batchelor  
**Cc:** katie.morphet@ottawa.ca; Brad Moore; Jordan Lupovici; Jonah Bonn  
**Subject:** RE: Future Halo carwash Borrisokane Rd. Barrhaven ON. (LRL#210691)

Hi Philippe,

As for the floodplain, mapping below shows that the floodplain does not extend onto the property. This was confirmed and updated on our end earlier this year, and mapping at the City should be updated through an omnibus zoning amendment.

As for SWM and TSS removal, you are required to maintain enhanced water quality protection either through on-site or down stream infrastructure prior to any outlet to a natural watercourse. Note that setbacks and stormwater should take into consideration the realigned channel adjacent to your site (along the easterly property boundary).

Given the use, I would also suggest you contact the City's HydroG related to any groundwater constraints given the use.

Cheers,



**Eric Lalande, MCIP, RPP**  
Planner, RVCA  
613-692-3571 x1137

---

**From:** Philippe Paquette <ppaquette@lrl.ca>  
**Sent:** Thursday, September 23, 2021 4:25 PM

**To:** Jamie Batchelor <jamie.batchelor@rvca.ca>; Eric Lalande <eric.lalande@rvca.ca>

**Cc:** katie.morphet@ottawa.ca; Brad Moore <b.moore@macewen.ca>; Jordan Lupovici <jlupovici@halowash.com>;  
Jonah Bonn <jbonn@firstbay.ca>

**Subject:** Future Halo carwash Borrisokane Rd. Barrhaven ON. (LRL#210691)

Hi Jamie and Eric,

After pre-consulting with the City of Ottawa this morning regrading the above mentioned project, the City of Ottawa planner assigned to the file (Katie Morphet) gave me your contacts in order to discuss about the flood plain crossing this property, SWM and TSS removal criterion. To put you in context, our client wishes to purchase a piece of land located at the north end of the employment block of the Mattamy Homes Half Moon bay West Subdivision. Refer to the attached document for more info. Also attached is a preliminary plan of what they want to develop.

Let us know of your availability so we can book a meeting very soon.

Thanks for your time.

**Philippe Paquette, C.E.T.**

Certified Engineering Technologist



**LRL Engineering**

5430 Canotek Road  
Ottawa, Ontario K1J 9G2

**T** (613) 842-3434 or (877) 632-5664 ext 209

**C** (613) 880-9793

**F** (613) 842-4338

**E** [ppaquette@lrl.ca](mailto:ppaquette@lrl.ca)

**W** [www.lrl.ca](http://www.lrl.ca)

*Given the current COVID-19 situation, please be aware that LRL has implemented alternative working conditions for our team. Many of us have now transitioned to working from home; however, communication and workability remains one of our top priorities.*

*We will continue to be reachable by cell phone or by calling LRL at 613-842-3434 which will prompt you to enter the extension of the person you are trying to reach.*

*In addition, we will continue to have access to all e-mail correspondence and do our best to return all inquiries in a timely manner.*



**APPENDIX B**  
**Water Supply Calculations**



## Water Service Calculations

LRL File No. : 210691

Project : Proposed Development - Halo Car Wash

Location : 3555 Borrisokane Rd

Date : April 13, 2022

Designed by : M. Basnet

### Water Demand

Site area =  ha

Average day demand = 35000 L / ha-day (based on City of Ottawa guidelines)  
 = 18690 L / day  
 = **0.22** L / s

Maximum daily peak factor = 1.5  
**Maximum daily demand = 0.32** L / s

Maximum hour peak factor = 1.8  
**Maximum hour demand = 0.58** L / s

### Adjustment - Car Wash (as per Halo Car Wash Inc.)

Estimated vol. of water/car wash =  L

Average day demand = 93151 L / day (assuming 200000 car wash/year)  
**1.08** L / s

Maximum daily demand = **1.97** L / s (assuming 1000 car wash/day)

Maximum hour demand = **6.14** L / s (assuming 130 car wash/hour)

### Total Anticipated Water Demand

Average day demand = **1.29** L / s  
 Maximum daily demand = **2.29** L / s  
 Maximum hour demand = **6.72** L / s

### Water Service Pipe Sizing

$$Q = VA$$

Where: V = velocity

A = area of watermain pipe

Q = water supply flow rate

By deriving the above formula with V=1.5 m/s

Minimum pipe diameter:

$$d = (4Q/\pi V)^{1/2}$$

$$d = 0.076 \text{ m}$$

$$d = 76 \text{ mm (minimum required size)}$$

Proposed pipe diameter:

mm





**Fire Flow Calculations**

**LRL File No.** 210691

**Project:** Proposed Development-Halo Car Wash

**Location:** 3535 Borrisokane Rd, Barrhaven, ON

**Date:** April 14, 2022

**Method:** Fire Underwriters Survey (FUS)

**Prepared by:** M. Basnet

Step	Task	Term	Options	Multiplier	Choose:	Value	Unit	Fire Flow	
<b>Structural Framing Material</b>									
1	Choose frame used for building	Coefficient C related to the type of construction	Wood Frame	1.5	Non-combustible Construction	0.8			
			Ordinary Construction	1.0					
			Non-combustible construction	0.8					
			Fire resistive construction <2 hrs	0.7					
			Fire resistive construction >2 hrs	0.6					
<b>Floor Space Area (A)</b>									
2			Total area			485	m <sup>2</sup>		
3	Obtain fire flow before reductions	Required fire flow	$Fire\ Flow = 220 \times C \times A^{0.5}$				L/min	3,876	
<b>Reductions or surcharge due to factors affecting burning</b>									
4	Choose combustibility of contents	Occupancy hazard reduction or surcharge	Non-combustible	-25%	Combustible	0%	L/min	3,876	
			Limited combustible	-15%					
			Combustible	0%					
			Free burning	15%					
			Rapid burning	25%					
5	Choose reduction for sprinklers	Sprinkler reduction	Full automatic sprinklers	-30%	False	0%	L/min	3,876	
			Water supply is standard for both the system and fire department hose lines		-10%	False			0%
			Fully supervised system	-10%	False	0%			
6	Choose separation	Exposure distance between units	North side	>45m	0%	0%	L/min	3,876	
			East side	>45m	0%				
			South side	>45m	0%				
			West side	>45m	0%				
<b>Net required fire flow</b>									
7	Obtain fire flow, duration, and volume					Minimum required fire flow rate (rounded to nearest 100)	L/min	3,900	
						Minimum required fire flow rate	L/s	65.0	
						Required duration of fire flow	hr	1.5	



# Hydraulic Capacity and Modeling Analysis Mattamy Half Moon Bay West Phase 3

## Final Report

**Prepared for:**

David Schaeffer Engineering Ltd.  
120 Iber Road, Unit 103  
Stittsville, ON K2S 1E9

**Prepared by:**

GeoAdvice Engineering Inc.  
Unit 203, 2502 St. John's Street  
Port Moody, BC V3H 2B4

**Submission Date:** May 31, 2021

**Contact:** Mr. Werner de Schaetzen, Ph.D., P.Eng.

**Project:** 2021-033-DSE

Copyright © 2021 GeoAdvice Engineering Inc.

Project ID: 2021-033-DSE



Page | 1



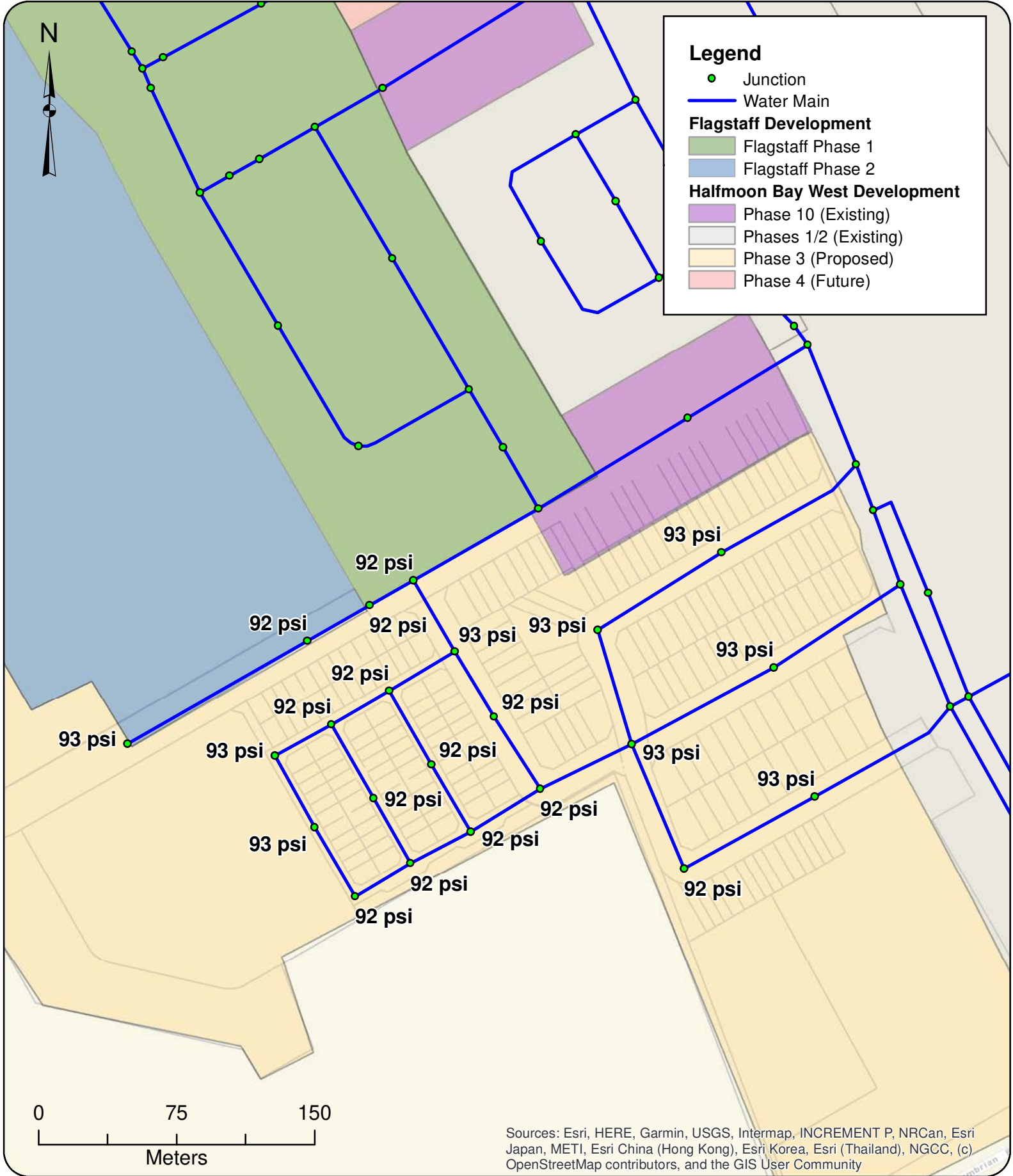

Sources: Esri, HERE, Garmin, USGS, Intermap, INCREMENT P, NRCan, Esri Japan, METI, Esri China (Hong Kong), Esri Korea, Esri (Thailand), NGCC, (c) OpenStreetMap contributors, and the GIS User Community



Project: **Hydraulic Capacity and Modeling Analysis**  
**Mattamy Half Moon Bay West Phase 3**  
 2021-033-DSE  
 Client: **David Schaeffer Engineering Ltd.**  
 Date: **May 2021**  
 Created by: **BL**  
 Reviewed by: **WdS**

DISCLAIMER: GeoAdvice does not warrant in any way the accuracy and completeness of the information shown on this map. Field verification of the accuracy and completeness of the information shown on this map is the sole responsibility of the user.

**MHD Pressure Results**  
**HMBW Phase 3**

---

**Figure E.1**

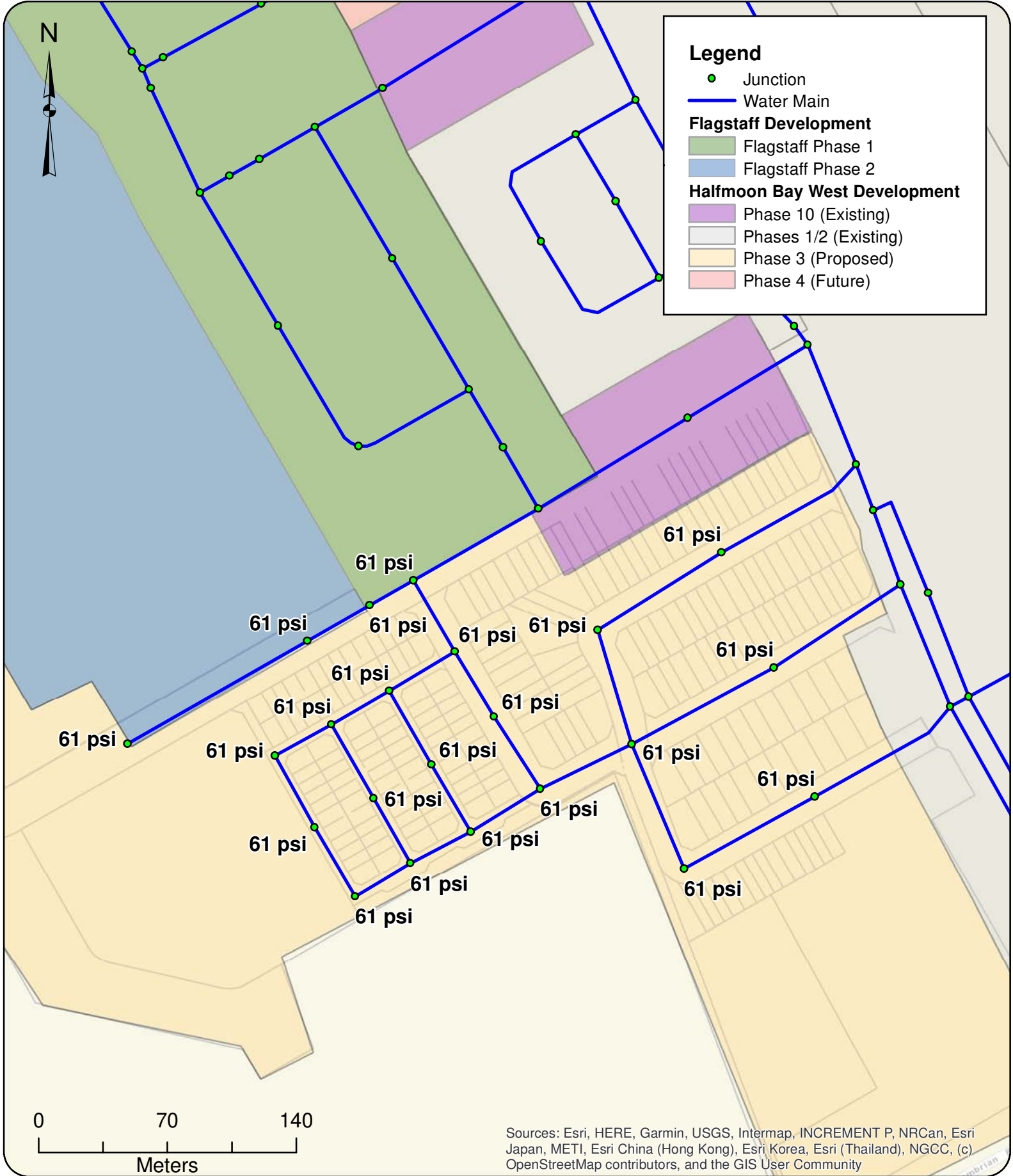

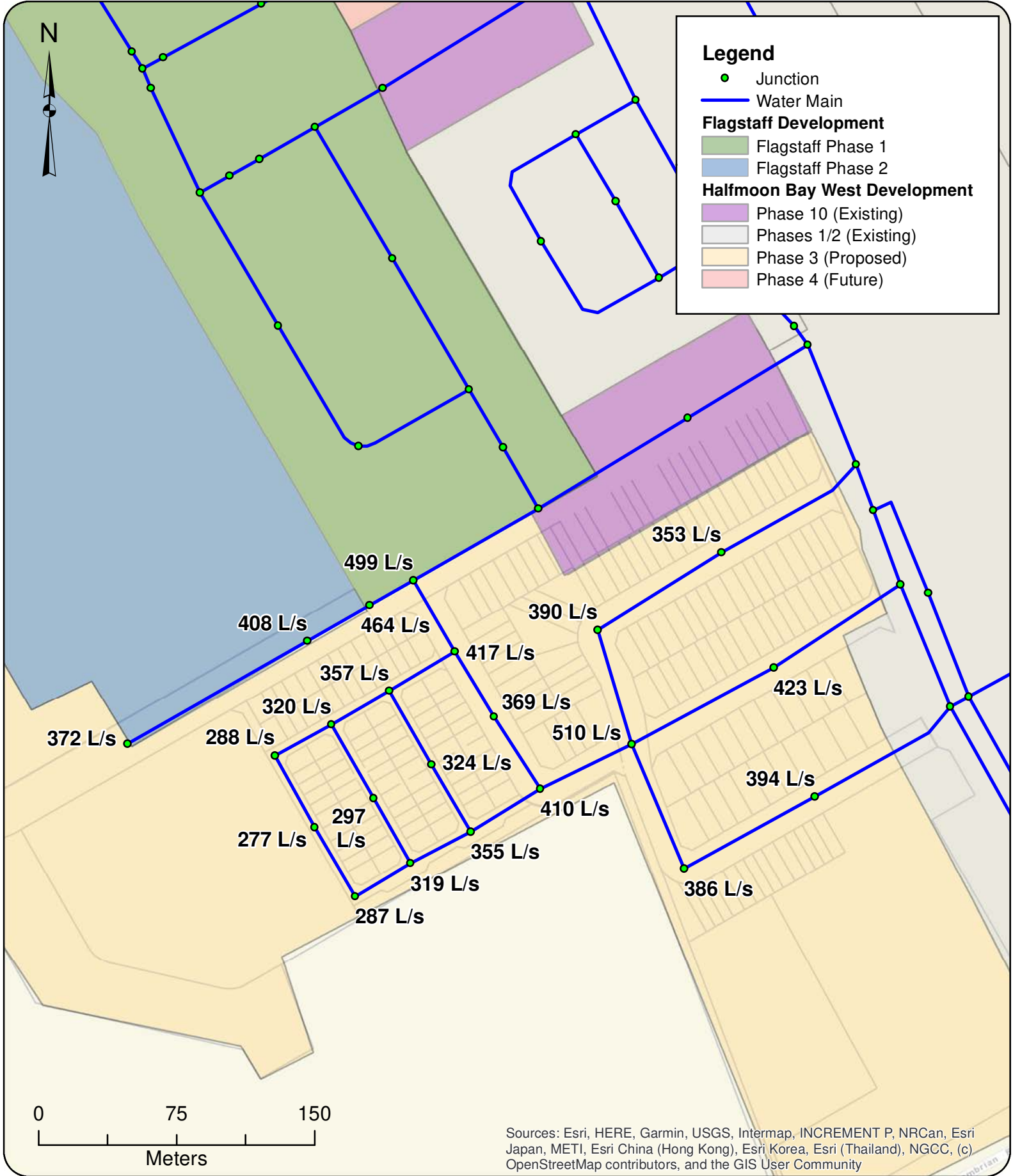

Sources: Esri, HERE, Garmin, USGS, Intermap, INCREMENT P, NRCan, Esri Japan, METI, Esri China (Hong Kong), Esri Korea, Esri (Thailand), NGCC, (c) OpenStreetMap contributors, and the GIS User Community



Project: **Hydraulic Capacity and Modeling Analysis  
Mattamy Half Moon Bay West Phase 3  
2021-033-DSE**  
Client: **David Schaeffer Engineering Ltd.**  
Date: **May 2021**  
Created by: **BL**  
Reviewed by: **WdS**

DISCLAIMER: GeoAdvice does not warrant in any way the accuracy and completeness of the information shown on this map. Field verification of the accuracy and completeness of the information shown on this map is the sole responsibility of the user.

**Available Fire Flow  
@ 20 psi  
HMBW Phase 3**

---

**Figure F.1**

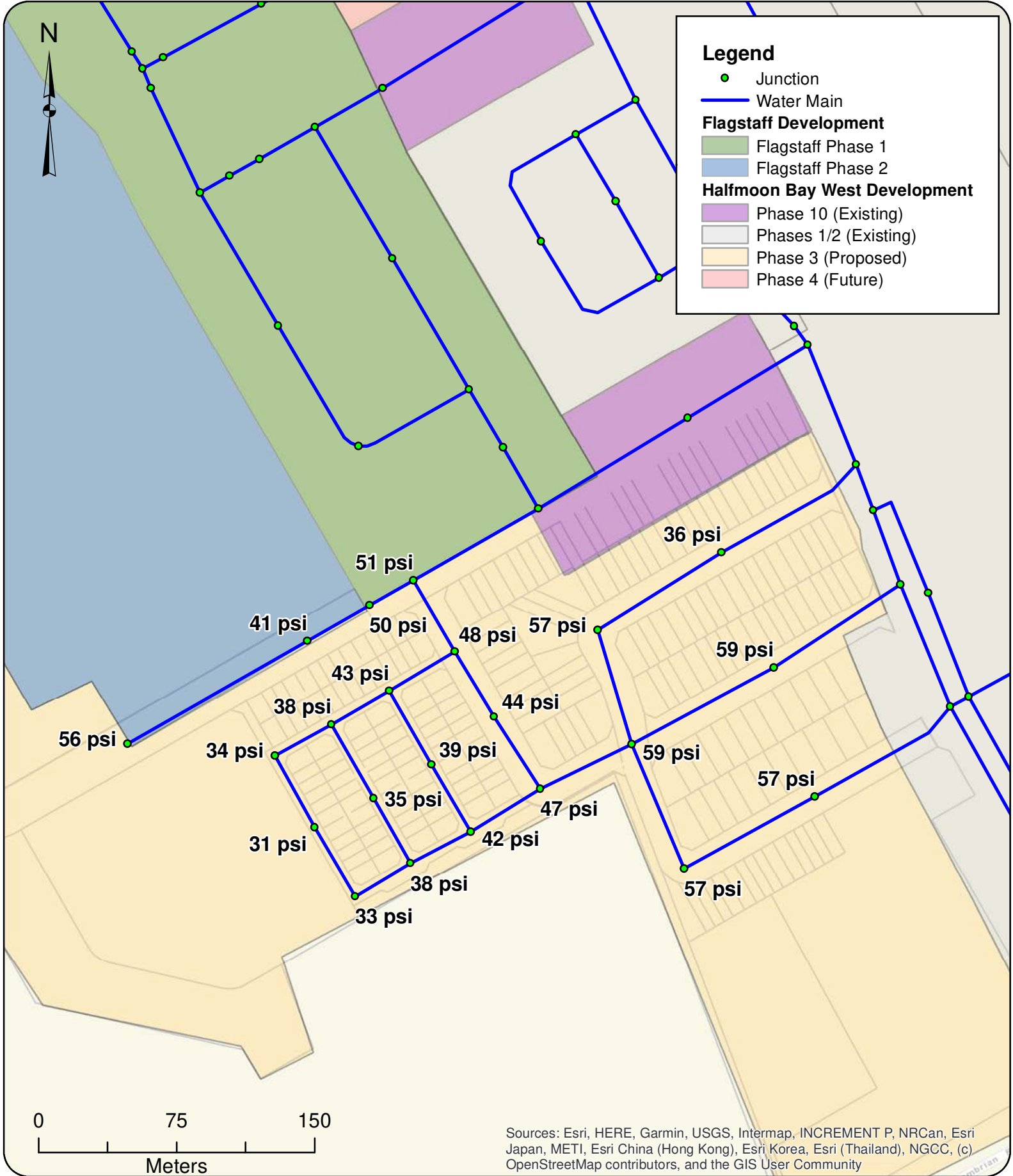

**Legend**

- Junction
- Water Main

**Flagstaff Development**

- Flagstaff Phase 1
- Flagstaff Phase 2

**Halfmoon Bay West Development**

- Phase 10 (Existing)
- Phases 1/2 (Existing)
- Phase 3 (Proposed)
- Phase 4 (Future)

Sources: Esri, HERE, Garmin, USGS, Intermap, INCREMENT P, NRCan, Esri Japan, METI, Esri China (Hong Kong), Esri Korea, Esri (Thailand), NGCC, (c) OpenStreetMap contributors, and the GIS User Community



Project: **Hydraulic Capacity and Modeling Analysis  
Mattamy Half Moon Bay West Phase 2  
2021-033-DSE**  
 Client: **David Schaeffer Engineering Ltd.**  
 Date: **May 2021**  
 Created by: **BL**  
 Reviewed by: **WdS**

DISCLAIMER: GeoAdvice does not warrant in any way the accuracy and completeness of the information shown on this map. Field verification of the accuracy and completeness of the information shown on this map is the sole responsibility of the user.

**Residual Pressure  
@ Required Fire Flow  
HMBW Phase 3**

---

**Figure F.2**

**APPENDIX C**  
**Wastewater Calculations**



**LRL File No.** 210691  
**Project:** Proposed Development-Halo Car Wash  
**Location:** 3535 Borrisokane Rd, Barrhaven, ON  
**Date:** April 22, 2022

**Sanitary Design Parameters**

Average Daily Flow = 280 L/p/day  
 Commercial & Institutional Flow = 28000 L/ha/day  
 Light Industrial Flow = 35000 L/ha/day  
 Heavy Industrial Flow = 55000 L/ha/day  
 Maximum Residential Peak Factor = 4.0  
 Commercial & Institutional Peak Factor = 1.5

Industrial Peak Factor = as per Appendix 4-B  
 Extraneous Flow = 0.33 L/s/gross ha  
 (as Per Tech Bulletin ISTB-2018-01)

**Pipe Design Parameters**

Minimum Velocity = 0.60 m/s  
 Manning's n = 0.013

LOCATION			RESIDENTIAL AREA AND POPULATION					COMMERCIAL		INDUSTRIAL			INSTITUTIONAL		C+I+I	INFILTRATION			*TOTAL FLOW	PIPE						
STREET/SITE	FROM MH	TO MH	AREA (Ha)	POP.	CUMMULATIVE		PEAK FACT.	PEAK FLOW (l/s)	AREA (Ha)	ACCU. AREA (Ha)	AREA (Ha)	ACCU. AREA (Ha)	PEAK FACT.	AREA (Ha)	ACCU. AREA (Ha)	*PEAK FLOW (l/s)	TOTAL AREA (Ha)	ACCU. AREA (Ha)	INFILT. FLOW (l/s)	*TOTAL FLOW (l/s)	LENGTH (m)	DIA. (mm)	SLOPE (%)	MATERIAL	CAP. (FULL) (l/s)	VEL. (FULL) (m/s)
					AREA (Ha)	POP.																				
SAN MH01		SAN MH02							0.534					6.141		0.534	0.53	0.18	6.32	36.8	150	1.57%	PVC	19.08	1.08	
		(on-site)																								
															Designed:	PROJECT:										
															M. B./M.L.	Proposed Halo Car Wash										
															Checked:	LOCATION:										
															M.B.	3535 Borrisokane Rd, Barrhaven, ON										
															Dwg. Reference:	File Ref.:	Date:			Sheet No.						
															C401	210691	2022-04-22			1 of 1						

Note:  
 \*Peak flow including anticipated waste water from Halo Car Wash (6.141 L/s), see below

Site Description	Qty	L/Qty	Total	
			L/day	L/s
<b>Halo Car Wash</b>				
Anticipated Employees	2	75	150	0.002
Total x Peak Factor (1.5)				<b>0.003</b>
Estimated Car Wash/Hour (based on info by Halo Car Wash)	130	170		<b>6.139</b>
<b>Total Anticipated Peak Design Flow</b> (dry weather flow)				<b>6.141</b>



**APPENDIX D**  
**Stormwater Management Calculations**

# LRL Associates Ltd.

## Storm Watershed Summary



**LRL File No.** 210691

**Project:** Proposed Development-Halo Car Wash

**Location:** 3555 Borrisokane Rd (Barrhaven, ON)

**Date:** April 6, 2022

**Designed:** M. Longtin

**Checked:** M. Basnet

**Dwg Reference:** C701, C702

### Pre-Development Catchments

Watershed	C = 0.20	C = 0.80	C = 0.90	Total Area (ha)	Combined C
EWS-01 (uncontrolled)	0.534	0.000	0.000	0.534	0.20
<b>Total</b>	<b>0.534</b>	<b>0.000</b>	<b>0.000</b>	<b>0.534</b>	<b>0.20</b>

### Post-Development Catchments

Watershed	C = 0.20	C = 0.8	C = 0.90	Total Area (ha)	Combined C
WS-01 (controlled)	0.045	0.000	0.019	0.064	0.41
WS-02 (controlled)	0.004	0.000	0.052	0.056	0.85
WS-03 (controlled)	0.030	0.000	0.066	0.096	0.68
WS-04 (controlled)	0.000	0.000	0.056	0.056	0.90
WS-05 (controlled)	0.000	0.000	0.115	0.115	0.90
WS-06 (controlled)	0.010	0.000	0.022	0.032	0.68
WS-07 (controlled)	0.029	0.000	0.017	0.046	0.46
WS-08 (uncontrolled)	0.027	0.000	0.000	0.027	0.20
WS-09 (uncontrolled)	0.041	0.000	0.001	0.042	0.22
<b>Total</b>	<b>0.186</b>	<b>0.000</b>	<b>0.348</b>	<b>0.534</b>	<b>0.66</b>



**LRL File No.** 210691  
**Project:** Proposed Development-Halo Car Wash  
**Location:** 3555 Borrisokane Rd (Barrhaven, ON)  
**Date:** April 12, 2022  
**Designed:** M. Longtin  
**Checked:** M. Basnet  
**Drawing Ref.:** C701, C702

**Stormwater Management  
Design Sheet**

**STORM - 100 YEAR**

Runoff Equation

Q = 2.78CIA (L/s)  
 C = Runoff coefficient  
 I = Rainfall intensity (mm/hr) =  $A / (Td + C)^B$   
 A = Area (ha)  
 T<sub>c</sub> = Time of concentration (min)

**Pre-Development Catchments within Development Area**

	Total Area =	0.534	ha	ΣR=	0.20
Un-Controlled	EWS-01	0.534	ha	R=	0.20
	Total Uncontrolled =	0.534	ha	ΣR=	0.20

**Pre-development Stormwater Management (5-Yr)**

$I_5 = 998.071 / (Td + 6.053)^{0.814}$       **A = 998.071**      **B = 0.814**      **C = 6.053**

C = 0.20 max of 0.5 as per City of Ottawa  
 I = 104.2 mm/hr  
 T<sub>c</sub> = 10 min  
 Total Area = 0.534 ha

**Pre-development Stormwater Management (100-Yr)**

$I_{100} = 1735.688 / (Td + 6.014)^{0.820}$       **A = 1735.688**      **B = 0.820**      **C = 6.014**

C = 0.66  
 I = 178.6 mm/hr  
 T<sub>c</sub> = 10 min  
 Total Area = 0.534 ha

**Allowable Release Rate = 30.95 L/s**

(5-yr pre-development level corresponding to EWS-01, see drawing C701)

**Post-development Stormwater Management**

					ΣR <sub>5</sub>	ΣR <sub>100</sub>
Controlled	Total Site Area =	0.534	ha	ΣR=	0.66	0.82
	WS-01	0.064	ha	R=	0.41	0.51
	WS-02	0.056	ha	R=	0.85	1.00
	WS-03	0.096	ha	R=	0.68	0.85
	WS-04	0.056	ha	R=	0.90	1.00
	WS-05	0.115	ha	R=	0.90	1.00
	WS-06	0.032	ha	R=	0.68	0.85
	WS-07	0.046	ha	R=	0.46	0.57
	Total Controlled =	0.465	ha	ΣR=	0.72	0.90
Uncontrolled	WS-08	0.027	ha	R=	0.20	0.25
	WS-09	0.042	ha	R=	0.22	0.28
	Total Uncontrolled =	0.069	ha	ΣR=	0.21	0.27

**Post-development Stormwater Management (100-Yr)**

Time (min)	Intensity (mm/hr)	Controlled Runoff (L/s)	Storage Volume (m <sup>3</sup> )	Controlled Release Rate (L/s)	Uncontrolled Runoff (L/s)	Total Release Rate (L/s)
10	178.56	208.26	111.91	21.74	9.21	30.95
15	142.89	166.66	130.42	21.74	7.37	29.11
20	119.95	139.90	141.79	21.74	6.19	27.93
25	103.85	121.12	149.06	21.74	5.36	27.10
30	91.87	107.15	153.72	21.74	4.74	26.48
35	82.58	96.31	156.59	21.74	4.26	26.00
40	75.15	87.64	158.16	21.74	3.88	25.62
45	69.05	80.53	158.73	21.74	3.56	25.31
50	63.95	74.59	158.54	21.74	3.30	25.04
55	59.62	69.54	157.73	21.74	3.07	24.82
60	55.89	65.19	156.41	21.74	2.88	24.63
65	52.65	61.40	154.67	21.74	2.71	24.46
70	49.79	58.07	152.57	21.74	2.57	24.31
75	47.26	55.11	150.17	21.74	2.44	24.18
80	44.99	52.47	147.50	21.74	2.32	24.06
85	42.95	50.10	144.60	21.74	2.22	23.96
90	41.11	47.95	141.50	21.74	2.12	23.86
95	39.43	45.99	138.22	21.74	2.03	23.78
100	37.90	44.21	134.77	21.74	1.95	23.70
105	36.50	42.57	131.18	21.74	1.88	23.63
110	35.20	41.06	127.46	21.74	1.82	23.56
115	34.01	39.66	123.62	21.74	1.75	23.50
120	32.89	38.37	119.67	21.74	1.70	23.44

**On-site stormwater detention**

Storage required = 158.73 m<sup>3</sup>  
 Storage provided = 213.39 m<sup>3</sup> (See Dwg C601)



LRL File No. 210691  
 Project: Proposed Development-Halo Car Wash  
 Location: 3555 Borrisokane Rd (Barrhaven, ON)  
 Date: April 12, 2022  
 Designed: M. Longtin  
 Checked: M. Basnet  
 Drawing Ref.: C701, C702

Stormwater Management  
 Design Sheet

**STORM - 100 YEAR + Stress Test**

**Runoff Equation**

Q = 2.78CIA (L/s)  
 C = Runoff coefficient  
 I = Rainfall intensity (mm/hr) = A / (Td + C)<sup>B</sup>  
 A = Area (ha)  
 T<sub>c</sub> = Time of concentration (min)

**Pre-Development Catchments within Development Area**

	Total Area =	0.534	ha	ΣR=	0.20
Un-Controlled	EWS-01	0.534	ha	R=	0.20
	Total Uncontrolled =	0.534	ha	ΣR=	0.20

**Pre-development Stormwater Management (5-Yr)**

$I_5 = 998.071 / (Td + 6.053)^{0.814}$       A = 998.071      B = 0.814      C = 6.053

C = 0.20 max of 0.5 as per City of Ottawa  
 I = 104.2 mm/hr  
 T<sub>c</sub> = 10 min  
 Total Area = 0.534 ha

**Pre-development Stormwater Management (100-Yr)**

$I_{100} = 1735.688 / (Td + 6.014)^{0.820}$       A = 1735.688      B = 0.820      C = 6.014

C = 0.66  
 I = 178.6 mm/hr  
 T<sub>c</sub> = 10 min  
 Total Area = 0.534 ha

Allowable Release Rate = 30.95 L/s

(5-yr pre-development level corresponding to EWS-01, see drawing C701)

**Post-development Stormwater Management**

					ΣR <sub>5</sub>	ΣR <sub>100</sub>
Controlled	Total Site Area =	0.534	ha	ΣR=	0.66	0.82
	WS-01	0.064	ha	R=	0.41	0.51
	WS-02	0.056	ha	R=	0.85	1.00
	WS-03	0.096	ha	R=	0.68	0.85
	WS-04	0.056	ha	R=	0.90	1.00
	WS-05	0.115	ha	R=	0.90	1.00
	WS-06	0.032	ha	R=	0.68	0.85
	WS-07	0.046	ha	R=	0.46	0.57
	Total Controlled =	0.465	ha	ΣR=	0.72	0.90
Uncontrolled	WS-08	0.027	ha	R=	0.20	0.25
	WS-09	0.042	ha	R=	0.22	0.28
	Total Uncontrolled =	0.069	ha	ΣR=	0.21	0.27

**Post-development Stormwater Management (100-Yr + Stress Test)**

Time (min)	*Intensity (mm/hr)	Controlled Runoff (L/s)	Storage Volume (m <sup>3</sup> )	Controlled Release Rate (L/s)	Uncontrolled Runoff (L/s)	Total Release Rate (L/s)
10	214.27	249.91	136.90	21.74	11.05	32.79
15	171.47	199.99	160.42	21.74	8.84	30.59
20	143.94	167.88	175.36	21.74	7.42	29.17
25	124.62	145.34	185.40	21.74	6.43	28.17
30	110.24	128.58	192.30	21.74	5.69	27.43
35	99.09	115.58	197.04	21.74	5.11	26.85
40	90.17	105.17	200.22	21.74	4.65	26.39
45	82.86	96.64	202.22	21.74	4.27	26.02
50	76.74	89.51	203.29	21.74	3.96	25.70
55	71.55	83.45	203.62	21.74	3.69	25.43
60	67.07	78.23	203.34	21.74	3.46	25.20
65	63.18	73.68	202.56	21.74	3.26	25.00
70	59.75	69.68	201.35	21.74	3.08	24.83
75	56.71	66.14	199.77	21.74	2.92	24.67
80	53.99	62.97	197.87	21.74	2.78	24.53
85	51.54	60.12	195.70	21.74	2.66	24.40
90	49.33	57.54	193.28	21.74	2.54	24.29
95	47.32	55.19	190.65	21.74	2.44	24.18
100	45.48	53.05	187.82	21.74	2.35	24.09
105	43.80	51.08	184.82	21.74	2.26	24.00
110	42.24	49.27	181.66	21.74	2.18	23.92
115	40.81	47.59	178.35	21.74	2.10	23.85
120	39.47	46.04	174.92	21.74	2.04	23.78

\*20% increase in intensity for stress test

**On-site stormwater detention**

Storage required = 203.62 m<sup>3</sup>  
 Storage provided = 213.39 m<sup>3</sup>

(See Dwg C601)



LRL File No. 210691  
 Project: Proposed Development-Halo Car Wash  
 Location: 3555 Borrisokane Rd (Barrhaven, ON)  
 Date: April 12, 2022  
 Designed: M. Longtin  
 Checked: M. Basnet  
 Drawing Ref.: C701, C702

Stormwater Management  
 Design Sheet

**STORM - 5 YEAR**

**Runoff Equation**

Q = 2.78CIA (L/s)  
 C = Runoff coefficient  
 I = Rainfall intensity (mm/hr) = A / (Td + C)<sup>B</sup>  
 A = Area (ha)  
 T<sub>c</sub> = Time of concentration (min)

**Pre-Development Catchments within Development Area**

	Total Area =	0.534	ha	ΣR=	0.20
Un-Controlled	EWS-01	0.534	ha	R=	0.20
	Total Uncontrolled =	0.534	ha	ΣR=	0.20

**Pre-development Stormwater Management (5-Yr)**

$I_5 = 998.071 / (Td + 6.053)^{0.814}$       A = 998.071      B = 0.814      C = 6.053

C = 0.20 max of 0.5 as per City of Ottawa  
 I = 104.2 mm/hr  
 T<sub>c</sub> = 10 min  
 Total Area = 0.534 ha

**Pre-development Stormwater Management (100-Yr)**

$I_{100} = 1735.688 / (Td + 6.014)^{0.820}$       A = 1735.688      B = 0.820      C = 6.014

C = 0.66  
 I = 178.6 mm/hr  
 T<sub>c</sub> = 10 min  
 Total Area = 0.534 ha

Allowable Release Rate = 30.95 L/s

(5-yr pre-development level corresponding to EWS-01, see drawing C701)

**Post-development Stormwater Management**

					ΣR <sub>5</sub>	ΣR <sub>100</sub>
Controlled	Total Site Area =	0.534	ha	ΣR=	0.66	0.82
	WS-01	0.064	ha	R=	0.41	0.51
	WS-02	0.056	ha	R=	0.85	1.00
	WS-03	0.096	ha	R=	0.68	0.85
	WS-04	0.056	ha	R=	0.90	1.00
	WS-05	0.115	ha	R=	0.90	1.00
	WS-06	0.032	ha	R=	0.68	0.85
	WS-07	0.046	ha	R=	0.46	0.57
	Total Controlled =	0.465	ha	ΣR=	0.72	0.90
Uncontrolled	WS-08	0.027	ha	R=	0.20	0.25
	WS-09	0.042	ha	R=	0.22	0.28
	Total Uncontrolled =	0.069	ha	ΣR=	0.21	0.27

**Post-development Stormwater Management (5-Yr)**

Time (min)	Intensity (mm/hr)	Controlled Runoff (L/s)	Storage Volume (m <sup>3</sup> )	Controlled Release Rate (L/s)	Uncontrolled Runoff (L/s)	Total Release Rate (L/s)
10	104.19	121.52	59.87	21.74	4.30	26.04
15	83.56	97.45	68.14	21.74	3.45	25.19
20	70.25	81.93	72.23	21.74	2.90	24.64
25	60.90	71.02	73.92	21.74	2.51	24.26
30	53.93	62.90	74.07	21.74	2.22	23.97
35	48.52	56.59	73.17	21.74	2.00	23.75
40	44.18	51.53	71.49	21.74	1.82	23.57
45	40.63	47.39	69.23	21.74	1.68	23.42
50	37.65	43.92	66.51	21.74	1.55	23.30
55	35.12	40.96	63.43	21.74	1.45	23.19
60	32.94	38.42	60.04	21.74	1.36	23.10
65	31.04	36.21	56.40	21.74	1.28	23.03
70	29.37	34.26	52.55	21.74	1.21	22.96
75	27.89	32.53	48.52	21.74	1.15	22.90
80	26.56	30.98	44.33	21.74	1.10	22.84
85	25.37	29.59	40.00	21.74	1.05	22.79
90	24.29	28.33	35.55	21.74	1.00	22.75
95	23.31	27.18	30.99	21.74	0.96	22.71
100	22.41	26.13	26.33	21.74	0.92	22.67
105	21.58	25.17	21.59	21.74	0.89	22.63
110	20.82	24.29	16.77	21.74	0.86	22.60
115	20.12	23.47	11.88	21.74	0.83	22.57
120	19.47	22.71	6.92	21.74	0.80	22.55

**On-site stormwater detention**

Storage required = 74.07 m<sup>3</sup>  
 Storage provided = 213.39 m<sup>3</sup>

(See Dwg C601)

# Cut/Fill Report

**Generated:** 2022-02-10 13:15:01

**By user:** mlongtin

**Drawing:** W:\FILES 2021\210691\06 CivilDesign\02 Drawings\07  
FinalProductionDrawings\W:\FILES 2021\210691\06 CivilDesign\02  
Drawings\07 FinalProductionDrawings\210691-01.dwg

Volume Summary							
Name	Type	Cut Factor	Fill Factor	2d Area (hectares)	Cut (Cu. M.)	Fill (Cu. M.)	Net (Cu. M.)
CBMH02 PONDING	full	1.00	1.00	0.00	0.01	1.38	1.36<Fill>
CBMH03 PONDING	full	1.00	1.00	0.02	0.00	14.09	14.09<Fill>
CB04 PONDING	full	1.00	1.00	0.03	63.58	33.26	30.32<Cut>
CBMH05 PONDING	full	1.00	1.00	0.03	0.04	26.87	26.83<Fill>
CBMH06 PONDING	full	1.00	1.00	0.03	0.00	22.88	22.88<Fill>
CB07 PONDING	full	1.00	1.00	0.01	0.05	10.95	10.90<Fill>
CBMH10 PONDING	full	1.00	1.00	0.01	0.03	3.94	3.91<Fill>

Totals						
			2d Area (hectares)	Cut (Cu. M.)	Fill (Cu. M.)	Net (Cu. M.)
Total			0.13	63.72	113.36	49.64<Fill>

\* Value adjusted by cut or fill factor other than 1.0

LRL Associates Ltd.  
Storm Design Sheet



**LRL File No.** 210691  
**Project:** Proposed Development-Halo Car Wash  
**Location:** 3555 Borrisokane Rd (Barrhaven, ON)  
**Date:** April 12, 2022  
**Designed:** M. Longtin  
**Checked:** M. Basnet  
**Drawing Reference:** C702, C401

**Storm Design Parameters**

<u>Rational Method</u>	<u>Runoff Coefficient (C)</u>	<u>City of Ottawa IDF curve equation</u>
Q = 2.78CIA	Grass 0.20	(5 year event, intensity in mm/hr)
Q = Peak flow (L/s)	Gravel 0.80	$I_5 = 998.071 / (Td + 6.053)^{0.814}$
A = Drainage area (ha)	Asphalt / rooftop 0.90	Min. velocity = 0.80 m/s
C = Runoff coefficient		Manning's "n" = 0.013
I = Rainfall intensity (mm/hr)		

LOCATION			AREA (ha)			FLOW					STORM SEWER								
WATERSHED / STREET	From MH	To MH	C = 0.20	C = 0.80	C = 0.90	Indiv. 2.78AC	Accum. 2.78AC	Time of Conc. (min.)	Rainfall Intensity (mm/hr)	Peak Flow Q (L/s)	Controlled Flow Q (L/s)	Pipe Diameter (mm)	Type	Slope (%)	Length (m)	Capacity Full (L/s)	Velocity Full (m/s)	Time of Flow (min.)	Ratio (Q/Q <sub>FULL</sub> )
WS-01	CBMH02	CBMH03	0.045	0.000	0.019	0.07	0.07	10.00	104.19	7.54		250	PVC	0.45%	22.9	39.9	0.81	0.47	0.19
WS-02	CBMH03	CBMH05	0.004	0.000	0.052	0.13	0.20	10.47	101.78	20.78		250	PVC	0.45%	16.7	39.9	0.81	0.34	0.52
WS-03	CB04	CBMH05	0.030	0.000	0.066	0.18	0.18	10.00	104.19	18.92		250	PVC	0.45%	14.9	39.9	0.81	0.31	0.47
WS-04	CBMH05	CBMH06	0.000	0.000	0.056	0.14	0.53	10.65	100.89	53.12		300	PVC	0.35%	21.7	57.2	0.81	0.45	0.93
WS-05	CBMH06	CBMH08	0.000	0.000	0.115	0.29	0.81	11.09	98.74	80.33		375	PVC	0.30%	23.2	96.0	0.87	0.44	0.84
WS-06	CB07	CBMH08	0.010	0.000	0.022	0.06	0.06	10.00	104.19	6.33		250	PVC	0.45%	10.1	39.9	0.81	0.21	0.16
	CBMH08	CBMH10					0.87	11.30	97.78	85.50		375	PVC	0.30%	17.2	96.0	0.87	0.33	0.89
	CB09	CBMH10	0.029	0.000	0.017	0.06	0.06	10.00	104.19	6.12		250	PVC	0.50%	15.7	42.0	0.86	0.31	0.15
WS-07	CBMH10	OGS					0.93	11.63	96.30	89.85	21.74	250	PVC	0.50%	3.3	42.0	0.86	0.06	0.52
	OGS	Ex. STM					0.93	11.70	96.01	89.59	21.74	250	PVC	0.50%	8.4	42.0	0.86	0.16	0.52

Note

The Peak flow will be controlled by an ICD at the outlet of STM CBMH10

Stormceptor® EF Sizing Report

<b>STORMCEPTOR®</b>		<b>ESTIMATED NET ANNUAL SEDIMENT (TSS) LOAD REDUCTION</b>		04/12/2022														
Province:	Ontario	Project Name:	3555 Borrisokane Rd.															
City:	Barrhaven	Project Number:	210691															
Nearest Rainfall Station:	OTTAWA CDA RCS	Designer Name:	Brandon O'Leary															
Climate Station Id:	6105978	Designer Company:	Forterra															
Years of Rainfall Data:	20	Designer Email:	brandon.oleary@forterrabp.com															
Site Name:	3555 Borrisokane Rd.	Designer Phone:	905-630-0359															
Drainage Area (ha):	0.465	EOR Name:	Mohan Basnet															
Runoff Coefficient 'c':	0.72	EOR Company:	LRL Associates Ltd.															
Particle Size Distribution:	Fine	EOR Email:																
Target TSS Removal (%):	80.0	EOR Phone:																
Required Water Quality Runoff Volume Capture (%):	90.0																	
Oil / Fuel Spill Risk Site?	Yes	<table border="1" style="width: 100%; border-collapse: collapse;"> <thead> <tr> <th colspan="2" style="text-align: center;"><b>Net Annual Sediment (TSS) Load Reduction Sizing Summary</b></th> </tr> <tr> <th style="width: 50%;">Stormceptor Model</th> <th style="width: 50%;">TSS Removal Provided (%)</th> </tr> </thead> <tbody> <tr> <td style="text-align: center;">EFO4</td> <td style="text-align: center;">88</td> </tr> <tr> <td style="text-align: center;">EFO6</td> <td style="text-align: center;">95</td> </tr> <tr> <td style="text-align: center;">EFO8</td> <td style="text-align: center;">98</td> </tr> <tr> <td style="text-align: center;">EFO10</td> <td style="text-align: center;">99</td> </tr> <tr> <td style="text-align: center;">EFO12</td> <td style="text-align: center;">100</td> </tr> </tbody> </table>			<b>Net Annual Sediment (TSS) Load Reduction Sizing Summary</b>		Stormceptor Model	TSS Removal Provided (%)	EFO4	88	EFO6	95	EFO8	98	EFO10	99	EFO12	100
<b>Net Annual Sediment (TSS) Load Reduction Sizing Summary</b>																		
Stormceptor Model	TSS Removal Provided (%)																	
EFO4	88																	
EFO6	95																	
EFO8	98																	
EFO10	99																	
EFO12	100																	
Upstream Flow Control?	No																	
Peak Conveyance (maximum) Flow Rate (L/s):																		
<p><b>Recommended Stormceptor EFO Model: EFO4</b></p> <p><b>Estimated Net Annual Sediment (TSS) Load Reduction (%): 88</b></p> <p><b>Water Quality Runoff Volume Capture (%): &gt; 90</b></p>																		





## Stormceptor<sup>®</sup> EF Sizing Report

### THIRD-PARTY TESTING AND VERIFICATION

► **Stormceptor<sup>®</sup> EF and Stormceptor<sup>®</sup> EFO** are the latest evolutions in the Stormceptor<sup>®</sup> oil-grit separator (OGS) technology series, and are designed to remove a wide variety of pollutants from stormwater and snowmelt runoff. These technologies have been third-party tested in accordance with the Canadian ETV **Procedure for Laboratory Testing of Oil-Grit Separators** and performance has been third-party verified in accordance with the **ISO 14034 Environmental Technology Verification (ETV)** protocol.

### PERFORMANCE

► **Stormceptor<sup>®</sup> EF and EFO** remove stormwater pollutants through gravity separation and floatation, and feature a patent-pending design that generates positive removal of total suspended solids (TSS) throughout each storm event, including high-intensity storms. Captured pollutants include sediment, free oils, and sediment-bound pollutants such as nutrients, heavy metals, and petroleum hydrocarbons. Stormceptor is sized to remove a high level of TSS from the frequent rainfall events that contribute the vast majority of annual runoff volume and pollutant load. The technology incorporates an internal bypass to convey excessive stormwater flows from high-intensity storms through the device without resuspension and washout (scour) of previously captured pollutants. Proper routine maintenance ensures high pollutant removal performance and protection of downstream waterways.

### PARTICLE SIZE DISTRIBUTION (PSD)

► The **Canadian ETV PSD** shown in the table below was used, or in part, for this sizing. This is the identical PSD that is referenced in the Canadian ETV **Procedure for Laboratory Testing of Oil-Grit Separators** for both sediment removal testing and scour testing. The Canadian ETV PSD contains a wide range of particle sizes in the sand and silt fractions, and is considered reasonably representative of the particle size fractions found in typical urban stormwater runoff.

Particle Size (µm)	Percent Less Than	Particle Size Fraction (µm)	Percent
1000	100	500-1000	5
500	95	250-500	5
250	90	150-250	15
150	75	100-150	15
100	60	75-100	10
75	50	50-75	5
50	45	20-50	10
20	35	8-20	15
8	20	5-8	10
5	10	2-5	5
2	5	<2	5

Stormceptor®EF Sizing Report

Rainfall Intensity (mm / hr)	Percent Rainfall Volume (%)	Cumulative Rainfall Volume (%)	Flow Rate (L/s)	Flow Rate (L/min)	Surface Loading Rate (L/min/m <sup>2</sup> )	Removal Efficiency (%)	Incremental Removal (%)	Cumulative Removal (%)
0.5	8.6	8.6	0.47	28.0	24.0	100	8.6	8.6
1	20.3	29.0	0.94	56.0	47.0	100	20.3	29.0
2	16.2	45.2	1.88	113.0	94.0	97	15.8	44.7
3	12.0	57.2	2.82	169.0	141.0	91	10.9	55.6
4	8.4	65.6	3.76	226.0	188.0	86	7.2	62.8
5	5.9	71.6	4.70	282.0	235.0	82	4.9	67.7
6	4.6	76.2	5.64	339.0	282.0	79	3.7	71.4
7	3.1	79.3	6.59	395.0	329.0	77	2.4	73.7
8	2.7	82.0	7.53	452.0	376.0	75	2.1	75.8
9	3.3	85.3	8.47	508.0	423.0	73	2.4	78.2
10	2.3	87.6	9.41	564.0	470.0	71	1.6	79.9
11	1.6	89.2	10.35	621.0	517.0	69	1.1	80.9
12	1.3	90.5	11.29	677.0	564.0	66	0.9	81.8
13	1.7	92.2	12.23	734.0	611.0	65	1.1	82.9
14	1.2	93.5	13.17	790.0	659.0	64	0.8	83.7
15	1.2	94.6	14.11	847.0	706.0	64	0.7	84.4
16	0.7	95.3	15.05	903.0	753.0	63	0.4	84.9
17	0.7	96.1	15.99	960.0	800.0	63	0.5	85.4
18	0.4	96.5	16.93	1016.0	847.0	63	0.2	85.6
19	0.4	96.9	17.87	1072.0	894.0	62	0.3	85.9
20	0.2	97.1	18.82	1129.0	941.0	62	0.1	86.0
21	0.5	97.5	19.76	1185.0	988.0	62	0.3	86.3
22	0.2	97.8	20.70	1242.0	1035.0	61	0.1	86.4
23	1.0	98.8	21.64	1298.0	1082.0	60	0.6	87.0
24	0.3	99.1	22.58	1355.0	1129.0	59	0.2	87.2
25	0.0	99.1	23.52	1411.0	1176.0	58	0.0	87.2
30	0.9	100.0	28.22	1693.0	1411.0	52	0.5	87.7
35	0.0	100.0	32.93	1976.0	1646.0	45	0.0	87.7
40	0.0	100.0	37.63	2258.0	1882.0	39	0.0	87.7
45	0.0	100.0	42.33	2540.0	2117.0	35	0.0	87.7
<b>Estimated Net Annual Sediment (TSS) Load Reduction =</b>								<b>88 %</b>

Climate Station ID: 6105978 Years of Rainfall Data: 20



Stormceptor® **EF** Sizing Report

RAINFALL DATA FROM OTTAWA CDA RCS RAINFALL STATION

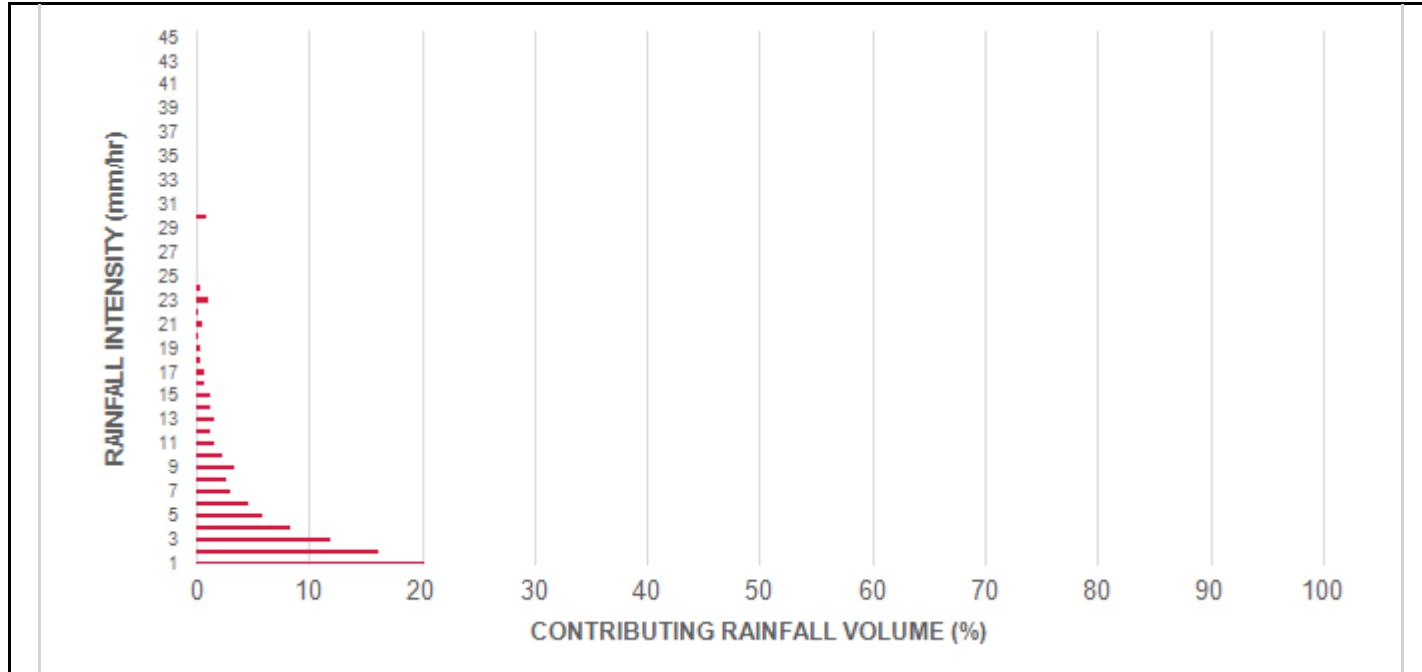

INCREMENTAL AND CUMULATIVE TSS REMOVAL FOR THE RECOMMENDED STORMCEPTOR® MODEL

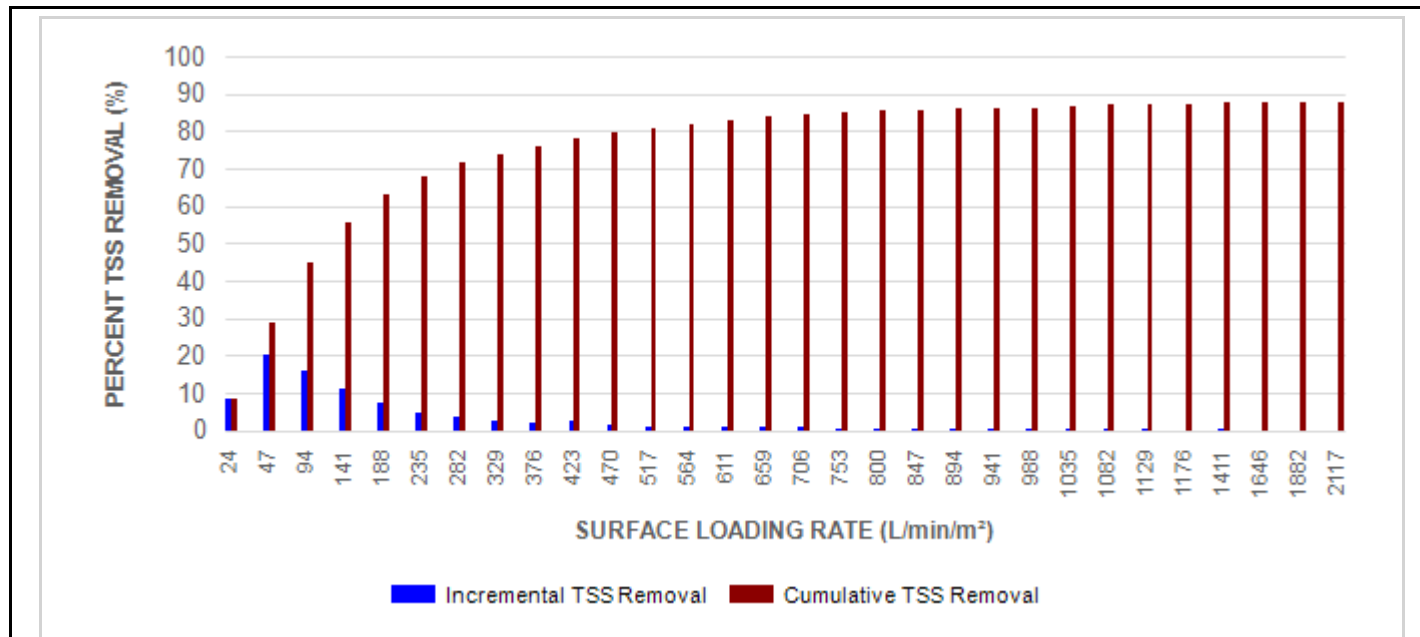

Stormceptor® EF Sizing Report

Maximum Pipe Diameter / Peak Conveyance

Stormceptor EF / EFO	Model Diameter		Min Angle Inlet / Outlet Pipes	Max Inlet Pipe Diameter		Max Outlet Pipe Diameter		Peak Conveyance Flow Rate	
	(m)	(ft)		(mm)	(in)	(mm)	(in)	(L/s)	(cfs)
EF4 / EFO4	1.2	4	90	609	24	609	24	425	15
EF6 / EFO6	1.8	6	90	914	36	914	36	990	35
EF8 / EFO8	2.4	8	90	1219	48	1219	48	1700	60
EF10 / EFO10	3.0	10	90	1828	72	1828	72	2830	100
EF12 / EFO12	3.6	12	90	1828	72	1828	72	2830	100

**SCOUR PREVENTION AND ONLINE CONFIGURATION**

► Stormceptor® EF and EFO feature an internal bypass and superior scour prevention technology that have been demonstrated in third-party testing according to the scour testing provisions of the Canadian ETV **Procedure for Laboratory Testing of Oil-Grit Separators**, and the exceptional scour test performance has been third-party verified in accordance with the ISO 14034 ETV protocol. As a result, Stormceptor EF and EFO are approved for online installation, eliminating the need for costly additional bypass structures, piping, and installation expense.

**DESIGN FLEXIBILITY**

► Stormceptor® EF and EFO offers design flexibility in one simplified platform, accepting stormwater flow from a single inlet pipe or multiple inlet pipes, and/or surface runoff through an inlet grate. The device can also serve as a junction structure, accommodate a 90-degree inlet-to-outlet bend angle, and can be modified to ensure performance in submerged conditions.

**OIL CAPTURE AND RETENTION**

► While Stormceptor® EF will capture and retain oil from dry weather spills and low intensity runoff, Stormceptor® EFO has demonstrated superior oil capture and greater than 99% oil retention in third-party testing according to the light liquid re-entrainment testing provisions of the Canadian ETV **Procedure for Laboratory Testing of Oil-Grit Separators**. Stormceptor EFO is recommended for sites where oil capture and retention is a requirement.



## Stormceptor® EF Sizing Report

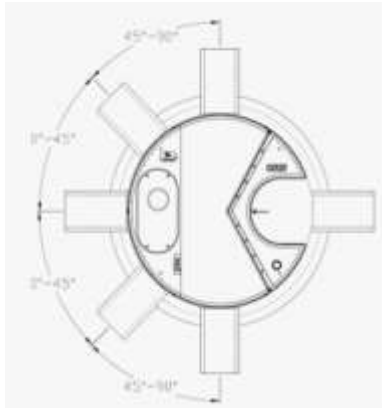

### INLET-TO-OUTLET DROP

Elevation differential between inlet and outlet pipe inverts is dictated by the angle at which the inlet pipe(s) enters the unit.

0° - 45° : The inlet pipe is 1-inch (25mm) higher than the outlet pipe.

45° - 90° : The inlet pipe is 2-inches (50mm) higher than the outlet pipe.

### HEAD LOSS

The head loss through Stormceptor EF is similar to that of a 60-degree bend structure. The applicable K value for calculating minor losses through the unit is 1.1.

For submerged conditions the applicable K value is 3.0.

### Pollutant Capacity

Stormceptor EF / EFO	Model Diameter		Depth (Outlet Pipe Invert to Sump Floor)		Oil Volume		Recommended Sediment Maintenance Depth *		Maximum Sediment Volume *		Maximum Sediment Mass **	
	(m)	(ft)	(m)	(ft)	(L)	(Gal)	(mm)	(in)	(L)	(ft³)	(kg)	(lb)
EF4 / EFO4	1.2	4	1.52	5.0	265	70	203	8	1190	42	1904	5250
EF6 / EFO6	1.8	6	1.93	6.3	610	160	305	12	3470	123	5552	15375
EF8 / EFO8	2.4	8	2.59	8.5	1070	280	610	24	8780	310	14048	38750
EF10 / EFO10	3.0	10	3.25	10.7	1670	440	610	24	17790	628	28464	78500
EF12 / EFO12	3.6	12	3.89	12.8	2475	655	610	24	31220	1103	49952	137875

\*Increased sump depth may be added to increase sediment storage capacity

\*\* Average density of wet packed sediment in sump = 1.6 kg/L (100 lb/ft³)

Feature	Benefit	Feature Appeals To
Patent-pending enhanced flow treatment and scour prevention technology	Superior, verified third-party performance	Regulator, Specifying & Design Engineer
Third-party verified light liquid capture and retention for EFO version	Proven performance for fuel/oil hotspot locations	Regulator, Specifying & Design Engineer, Site Owner
Functions as bend, junction or inlet structure	Design flexibility	Specifying & Design Engineer
Minimal drop between inlet and outlet	Site installation ease	Contractor
Large diameter outlet riser for inspection and maintenance	Easy maintenance access from grade	Maintenance Contractor & Site Owner

### STANDARD STORMCEPTOR EF/EFO DRAWINGS

For standard details, please visit <http://www.imbriumsystems.com/stormwater-treatment-solutions/stormceptor-ef>

### STANDARD STORMCEPTOR EF/EFO SPECIFICATION

For specifications, please visit <http://www.imbriumsystems.com/stormwater-treatment-solutions/stormceptor-ef>

## Stormceptor<sup>®</sup> EF Sizing Report

# STANDARD PERFORMANCE SPECIFICATION FOR “OIL GRIT SEPARATOR” (OGS) STORMWATER QUALITY TREATMENT DEVICE

## PART 1 – GENERAL

### 1.1 WORK INCLUDED

This section specifies requirements for selecting, sizing, and designing an underground Oil Grit Separator (OGS) device for stormwater quality treatment, with third-party testing results and a Statement of Verification in accordance with ISO 14034 Environmental Management – Environmental Technology Verification (ETV).

### 1.2 REFERENCE STANDARDS & PROCEDURES

ISO 14034:2016 Environmental management – Environmental technology verification (ETV)

Canadian Environmental Technology Verification (ETV) Program’s **Procedure for Laboratory Testing of Oil-Grit Separators**

### 1.3 SUBMITTALS

1.3.1 All submittals, including sizing reports & shop drawings, shall be submitted upon request with each order to the contractor then forwarded to the Engineer of Record for review and acceptance. Shop drawings shall detail all OGS components, elevations, and sequence of construction.

1.3.2 Alternative devices shall have features identical to or greater than the specified device, including: treatment chamber diameter, treatment chamber wet volume, sediment storage volume, and oil storage volume.

1.3.3 Unless directed otherwise by the Engineer of Record, OGS stormwater quality treatment product substitutions or alternatives submitted within ten days prior to project bid shall not be accepted. All alternatives or substitutions submitted shall be signed and sealed by a local registered Professional Engineer, based on the exact same criteria detailed in Section 3, in entirety, subject to review and approval by the Engineer of Record.

## PART 2 – PRODUCTS

### 2.1 OGS POLLUTANT STORAGE

The OGS device shall include a sump for sediment storage, and a protected volume for the capture and storage of petroleum hydrocarbons and buoyant gross pollutants. The minimum sediment & petroleum hydrocarbon storage capacity shall be as follows:

2.1.1	4 ft (1219 mm) Diameter OGS Units:	1.19 m <sup>3</sup> sediment / 265 L oil
	6 ft (1829 mm) Diameter OGS Units:	3.48 m <sup>3</sup> sediment / 609 L oil
	8 ft (2438 mm) Diameter OGS Units:	8.78 m <sup>3</sup> sediment / 1,071 L oil
	10 ft (3048 mm) Diameter OGS Units:	17.78 m <sup>3</sup> sediment / 1,673 L oil
	12 ft (3657 mm) Diameter OGS Units:	31.23 m <sup>3</sup> sediment / 2,476 L oil

## Stormceptor<sup>®</sup> EF Sizing Report

### PART 3 – PERFORMANCE & DESIGN

#### 3.1 GENERAL

The OGS stormwater quality treatment device shall be verified in accordance with ISO 14034:2016 Environmental management – Environmental technology verification (ETV). The OGS stormwater quality treatment device shall remove oil, sediment and gross pollutants from stormwater runoff during frequent wet weather events, and retain these pollutants during less frequent high flow wet weather events below the insert within the OGS for later removal during maintenance. The Manufacturer shall have at least ten (10) years of local experience, history and success in engineering design, manufacturing and production and supply of OGS stormwater quality treatment device systems, acceptable to the Engineer of Record.

#### 3.2 SIZING METHODOLOGY

The OGS device shall be engineered, designed and sized to provide stormwater quality treatment based on treating a minimum of 90 percent of the average annual runoff volume and a minimum removal of an annual average 60% of the sediment (TSS) load based on the Particle Size Distribution (PSD) specified in the sizing report for the specified device. Sizing of the OGS shall be determined by use of a minimum ten (10) years of local historical rainfall data provided by Environment Canada. Sizing shall also be determined by use of the sediment removal performance data derived from the ISO 14034 ETV third-party verified laboratory testing data from testing conducted in accordance with the Canadian ETV protocol Procedure for Laboratory Testing of Oil-Grit Separators, as follows:

3.2.1 Sediment removal efficiency for a given surface loading rate and its associated flow rate shall be based on sediment removal efficiency demonstrated at the seven (7) tested surface loading rates specified in the protocol, ranging 40 L/min/m<sup>2</sup> to 1400 L/min/m<sup>2</sup>, and as stated in the ISO 14034 ETV Verification Statement for the OGS device.

3.2.2 Sediment removal efficiency for surface loading rates between 40 L/min/m<sup>2</sup> and 1400 L/min/m<sup>2</sup> shall be based on linear interpolation of data between consecutive tested surface loading rates.

3.2.3 Sediment removal efficiency for surface loading rates less than the lowest tested surface loading rate of 40 L/min/m<sup>2</sup> shall be assumed to be identical to the sediment removal efficiency at 40 L/min/m<sup>2</sup>. No extrapolation shall be allowed that results in a sediment removal efficiency that is greater than that demonstrated at 40 L/min/m<sup>2</sup>.

3.2.4 Sediment removal efficiency for surface loading rates greater than the highest tested surface loading rate of 1400 L/min/m<sup>2</sup> shall assume zero sediment removal for the portion of flow that exceeds 1400 L/min/m<sup>2</sup>, and shall be calculated using a simple proportioning formula, with 1400 L/min/m<sup>2</sup> in the numerator and the higher surface loading rate in the denominator, and multiplying the resulting fraction times the sediment removal efficiency at 1400 L/min/m<sup>2</sup>.

The OGS device shall also have sufficient annual sediment storage capacity as specified and calculated in Section 2.1.

#### 3.3 CANADIAN ETV or ISO 14034 ETV VERIFICATION OF SCOUR TESTING

The OGS device shall have Canadian ETV or ISO 14034 ETV Verification of third-party scour testing conducted in

## Stormceptor<sup>®</sup> EF Sizing Report

accordance with the Canadian ETV Program's **Procedure for Laboratory Testing of Oil-Grit Separators**.

3.3.1 To be acceptable for on-line installation, the OGS device must demonstrate an average scour test effluent concentration less than 10 mg/L at each surface loading rate tested, up to and including 2600 L/min/m<sup>2</sup>.

### 3.4 LIGHT LIQUID RE-ENTRAINMENT SIMULATION TESTING

The OGS device shall have Canadian ETV or ISO 14034 ETV Verification of completed third-party Light Liquid Re-entrainment Simulation Testing in accordance with the Canadian ETV **Program's Procedure for Laboratory Testing of Oil-Grit Separators**, with results reported within the Canadian ETV or ISO 14034 ETV verification. This re-entrainment testing is conducted with the device pre-loaded with low density polyethylene (LDPE) plastic beads as a surrogate for light liquids such as oil and fuel. Testing is conducted on the same OGS unit tested for sediment removal to assess whether light liquids captured after a spill are effectively retained at high flow rates.

3.4.1 For an OGS device to be an acceptable stormwater treatment device on a site where vehicular traffic occurs and the potential for an oil or fuel spill exists, the OGS device must have reported verified performance results of greater than 99% cumulative retention of LDPE plastic beads for the five specified surface loading rates (ranging 200 L/min/m<sup>2</sup> to 2600 L/min/m<sup>2</sup>) in accordance with the Light Liquid Re-entrainment Simulation Testing within the Canadian ETV Program's **Procedure for Laboratory Testing of Oil-Grit Separators**. However, an OGS device shall not be allowed if the Light Liquid Re-entrainment Simulation Testing was performed with screening components within the OGS device that are effective at retaining the LDPE plastic beads, but would not be expected to retain light liquids such as oil and fuel.



# STANDARD PERFORMANCE SPECIFICATION FOR “OIL GRIT SEPARATOR” (OGS) STORMWATER QUALITY TREATMENT DEVICE

## PART 1 – GENERAL

### 1.1 WORK INCLUDED

This section specifies requirements for selecting, sizing, and designing an underground Oil Grit Separator (OGS) device for stormwater quality treatment, with third-party testing results and a Statement of Verification in accordance with ISO 14034 Environmental Management – Environmental Technology Verification (ETV).

### 1.2 REFERENCE STANDARDS & PROCEDURES

ISO 14034:2016 Environmental management – Environmental technology verification (ETV)

Canadian Environmental Technology Verification (ETV) Program’s **Procedure for Laboratory Testing of Oil-Grit Separators**

### 1.3 SUBMITTALS

1.3.1 All submittals, including sizing reports & shop drawings, shall be submitted upon request with each order to the contractor then forwarded to the Engineer of Record for review and acceptance. Shop drawings shall detail all OGS components, elevations, and sequence of construction.

1.3.2 Alternative devices shall have features identical to or greater than the specified device, including: treatment chamber diameter, treatment chamber wet volume, sediment storage volume, and oil storage volume.

1.3.3 Unless directed otherwise by the Engineer of Record, OGS stormwater quality treatment product substitutions or alternatives submitted within ten days prior to project bid shall not be accepted. All alternatives or substitutions submitted shall be signed and sealed by a local registered Professional Engineer, based on the exact same criteria detailed in Section 3, in entirety, subject to review and approval by the Engineer of Record.

## PART 2 – PRODUCTS

### 2.1 OGS POLLUTANT STORAGE

The OGS device shall include a sump for sediment storage, and a protected volume for the capture and storage of petroleum hydrocarbons and buoyant gross pollutants. The **minimum** sediment & petroleum hydrocarbon storage capacity shall be as follows:

2.1.1	4ft (1219mm) Diameter OGS Units:	1.19m <sup>3</sup> sediment / 265L oil
	6ft (1829mm) Diameter OGS Units:	3.48m <sup>3</sup> sediment / 609L oil
	8ft (2438mm) Diameter OGS Units:	8.78m <sup>3</sup> sediment / 1,071L oil
	10ft (3048mm) Diameter OGS Units:	17.78m <sup>3</sup> sediment / 1,673L oil
	12ft (3657mm) Diameter OGS Units:	31.23m <sup>3</sup> sediment / 2,476L oil

## PART 3 – PERFORMANCE & DESIGN

### 3.1 GENERAL

The OGS stormwater quality treatment device shall be verified in accordance with ISO 14034:2016 Environmental management – Environmental technology verification (ETV). The OGS stormwater quality

treatment device shall remove oil, sediment and gross pollutants from stormwater runoff during frequent wet weather events, and retain these pollutants during less frequent high flow wet weather events below the insert within the OGS for later removal during maintenance. The Manufacturer shall have at least ten (10) years of local experience, history and success in engineering design, manufacturing and production and supply of OGS stormwater quality treatment device systems, acceptable to the Engineer of Record.

### 3.2 SIZING METHODOLOGY

The OGS device shall be engineered, designed and sized to provide stormwater quality treatment based on treating a minimum of 90 percent of the average annual runoff volume and a minimum removal of an annual average 60% of the sediment (TSS) load based on the Particle Size Distribution (PSD) specified in the sizing report for the specified device. Sizing shall be determined using historical rainfall data and a sediment removal performance curve derived from the actual third-party verified laboratory testing data. The OGS device shall also have sufficient annual sediment storage capacity as specified and calculated in Section 2.1.

### 3.3 CANADIAN ETV or ISO 14034 ETV VERIFICATION OF SCOUR TESTING

The OGS device shall have Canadian ETV or ISO 14034 ETV Verification of third-party scour testing conducted in accordance with the Canadian ETV Program's **Procedure for Laboratory Testing of Oil-Grit Separators**.

3.3.1 To be acceptable for on-line installation, the OGS device must demonstrate an average scour test effluent concentration less than 10 mg/L at each surface loading rate tested, up to and including 2600 L/min/m<sup>2</sup>.

### 3.4 LIGHT LIQUID RE-ENTRAINMENT SIMULATION TESTING

The OGS device shall have Canadian ETV or ISO 14034 ETV Verification of completed third-party Light Liquid Re-entrainment Simulation Testing in accordance with the Canadian ETV Program's **Procedure for Laboratory Testing of Oil-Grit Separators**, with results reported within the Canadian ETV or ISO 14034 ETV verification. This re-entrainment testing is conducted with the device pre-loaded with low density polyethylene (LDPE) plastic beads as a surrogate for light liquids such as oil and fuel. Testing is conducted on the same OGS unit tested for sediment removal to assess whether light liquids captured after a spill are effectively retained at high flow rates.

3.4.1 For an OGS device to be an acceptable stormwater treatment device on a site where vehicular traffic occurs and the potential for an oil or fuel spill exists, the OGS device must have reported verified performance results of greater than 99% cumulative retention of LDPE plastic beads for the five specified surface loading rates (ranging 200 L/min/m<sup>2</sup> to 2600 L/min/m<sup>2</sup>) in accordance with the Light Liquid Re-entrainment Simulation Testing within the Canadian ETV Program's **Procedure for Laboratory Testing of Oil-Grit Separators**. However, an OGS device shall not be allowed if the Light Liquid Re-entrainment Simulation Testing was performed with screening components within the OGS device that are effective at retaining the LDPE plastic beads, but would not be expected to retain light liquids such as oil and fuel.

# CSO/STORMWATER MANAGEMENT



**HYDROVEX<sup>®</sup> VHV / SVHV**  
Vertical Vortex Flow Regulator

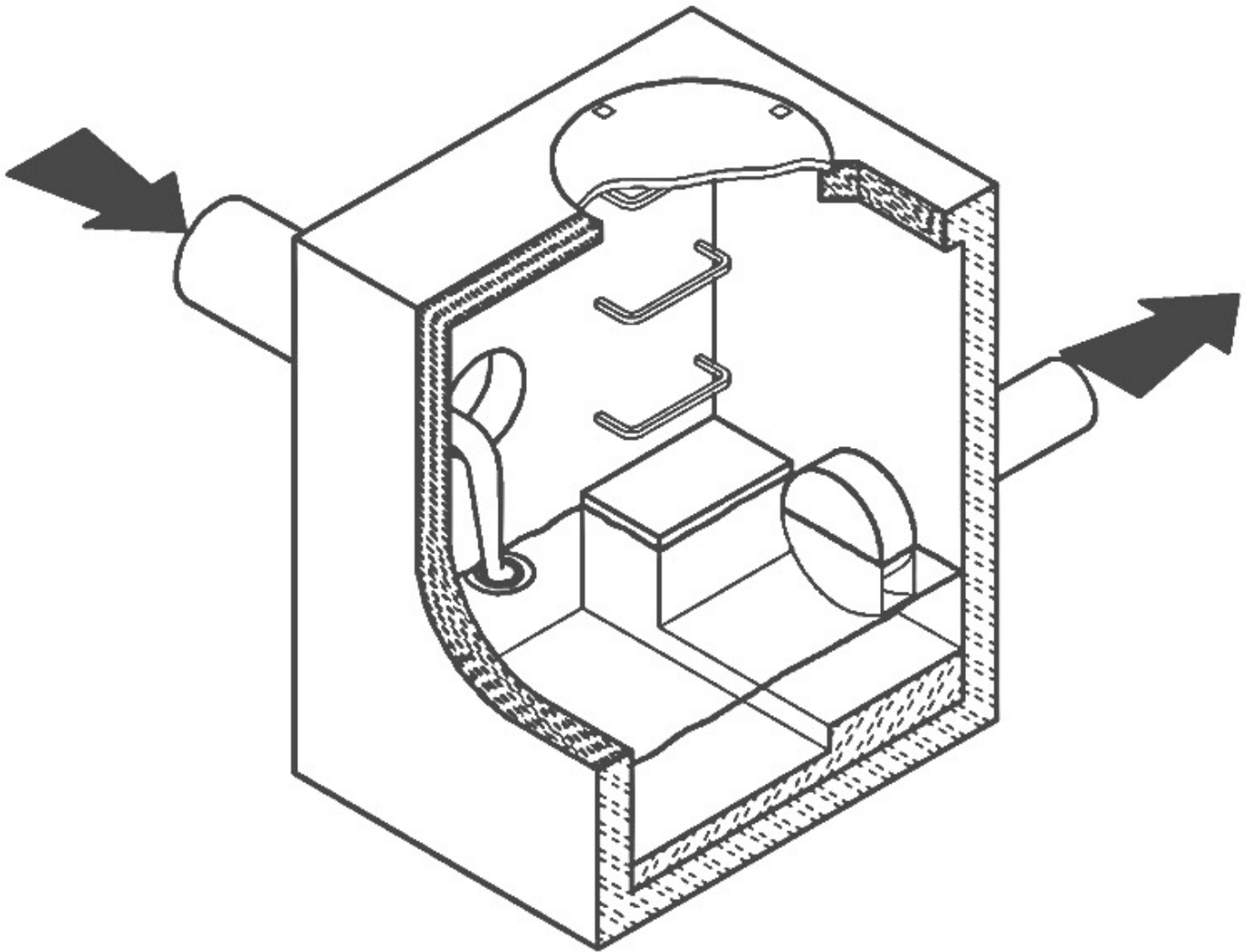

**JOHN MEUNIER**

# HYDROVEX® VHV / SVHV VERTICAL VORTEX FLOW REGULATOR

## APPLICATIONS

One of the major problems of urban wet weather flow management is the runoff generated after a heavy rainfall. During a storm, uncontrolled flows may overload the drainage system and cause flooding. Due to increased velocities, sewer pipe wear is increased dramatically and results in network deterioration. In a combined sewer system, the wastewater treatment plant may also experience significant increases in flows during storms, thereby losing its treatment efficiency.

A simple means of controlling excessive water runoff is by controlling excessive flows at their origin (manholes). **John Meunier Inc.** manufactures the **HYDROVEX® VHV / SVHV** line of vortex flow regulators to control stormwater flows in sewer networks, as well as manholes.

The vortex flow regulator design is based on the fluid mechanics principle of the forced vortex. This grants flow regulation without any moving parts, thus reducing maintenance. The operation of the regulator, depending on the upstream head and discharge, switches between orifice flow (gravity flow) and vortex flow. Although the concept is quite simple, over 12 years of research have been carried out in order to get a high performance.

The **HYDROVEX® VHV / SVHV** Vertical Vortex Flow Regulators (refer to **Figure 1**) are manufactured entirely of stainless steel, and consist of a hollow body (1) (in which flow control takes place) and an outlet orifice (7). Two rubber "O" rings (3) seal and retain the unit inside the outlet pipe. Two stainless steel retaining rings (4) are welded on the outlet sleeve to ensure that there is no shifting of the "O" rings during installation and use.

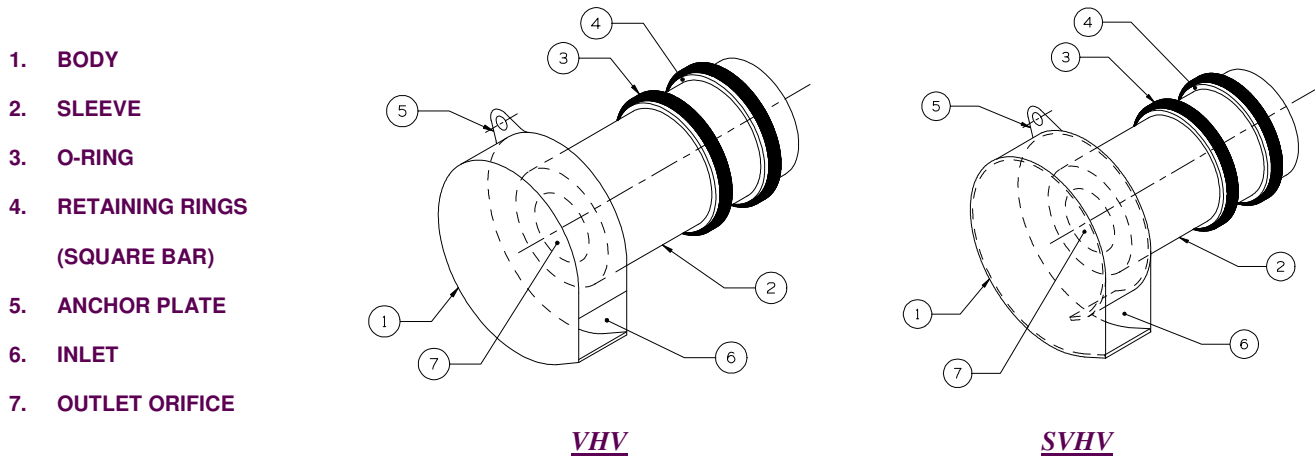

**FIGURE 1: HYDROVEX® VHV-SVHV VERTICAL VORTEX FLOW REGULATORS**

## ADVANTAGES

- The **HYDROVEX® VHV / SVHV** line of flow regulators are manufactured entirely of stainless steel, making them durable and corrosion resistant.
- Having no moving parts, they require minimal maintenance.
- The geometry of the **HYDROVEX® VHV / SVHV** flow regulators allows a control equal to an orifice plate, having a cross section area 4 to 6 times smaller. This decreases the chance of blockage of the regulator, due to sediments and debris found in stormwater flows. **Figure 2** illustrates the comparison between a regulator model 100 SVHV-2 and an equivalent orifice plate. One can see that for the same height of water, the regulator controls a flow approximately four times smaller than an equivalent orifice plate.
- Installation of the **HYDROVEX® VHV / SVHV** flow regulators is quick and straightforward and is performed after all civil works are completed.
- Installation requires no special tools or equipment and may be carried out by any contractor.
- Installation may be carried out in existing structures.

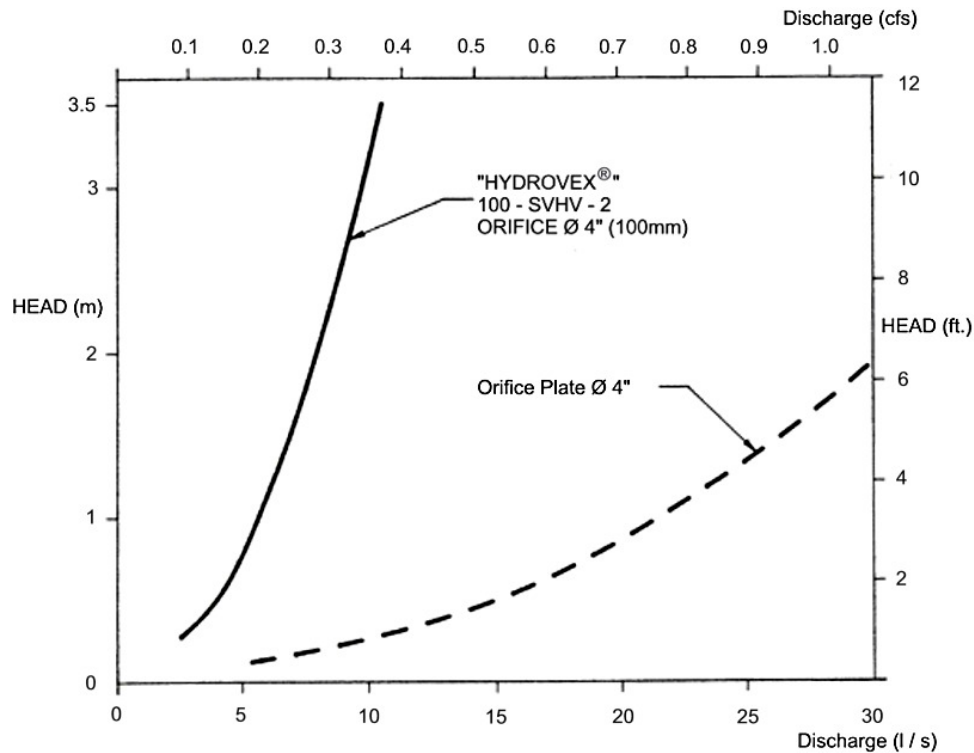

**FIGURE 2: DISCHARGE CURVE SHOWING A HYDROVEX® FLOW REGULATOR VS AN ORIFICE PLATE**

## SELECTION

Selection of a **VHV** or **SVHV** regulator can be easily made using the selection charts found at the back of this brochure (see **Figure 3**). These charts are a graphical representation of the maximum upstream water pressure (head) and the maximum discharge at the manhole outlet. The maximum design head is the difference between the maximum upstream water level and the invert of the outlet pipe. All selections should be verified by John Meunier Inc. personnel prior to fabrication.

### Example:

- ✓ Maximum design head      2m (6.56 ft.)
- ✓ Maximum discharge        6 L/s (0.2 cfs)
- ✓ Using **Figure 3** - VHV      model required is a **75 VHV-1**

## INSTALLATION REQUIREMENTS

All **HYDROVEX®** **VHV** / **SVHV** flow regulators can be installed in circular or square manholes. **Figure 4** gives the various minimum dimensions required for a given regulator. *It is imperative to respect the minimum clearances shown to ensure easy installation and proper functioning of the regulator.*

## SPECIFICATIONS

In order to specify a **HYDROVEX**<sup>®</sup> regulator, the following parameters must be defined:

- The model number (ex: 75-VHV-1)
- The diameter and type of outlet pipe (ex: 6" diam. SDR 35)
- The desired discharge (ex: 6 l/s or 0.21 CFS)
- The upstream head (ex: 2 m or 6.56 ft.) \*
- The manhole diameter (ex: 36" diam.)
- The minimum clearance "H" (ex: 10 inches)
- The material type (ex: 304 s/s, 11 Ga. standard)

\* *Upstream head is defined as the difference in elevation between the maximum upstream water level and the invert of the outlet pipe where the **HYDROVEX**<sup>®</sup> flow regulator is to be installed.*

**PLEASE NOTE THAT WHEN REQUESTING A PROPOSAL, WE SIMPLY REQUIRE THAT YOU PROVIDE US WITH THE FOLLOWING:**

- *project design flow rate*
- *pressure head*
- *chamber's outlet pipe diameter and type*



*Typical VHV model in factory*

# OPTIONS



*FV – SVHV (mounted on sliding plate)*



*VHV-1-O (standard model with odour control inlet)*

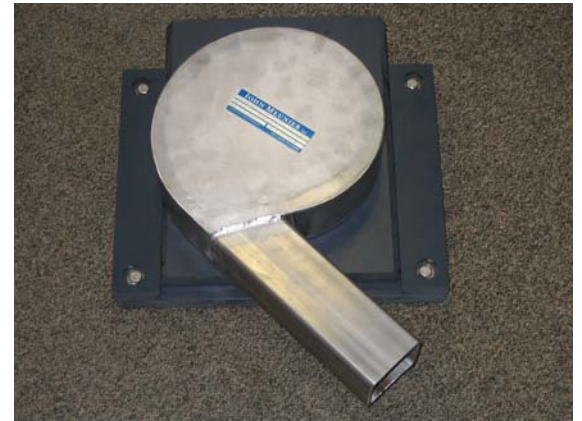

*FV – VHV-O (mounted on sliding plate with odour control inlet)*



*VHV with Gooseneck assembly in existing chamber without minimum release at the bottom*



*VHV with air vent for minimal slopes*



# VHV Vertical Vortex Flow Regulator

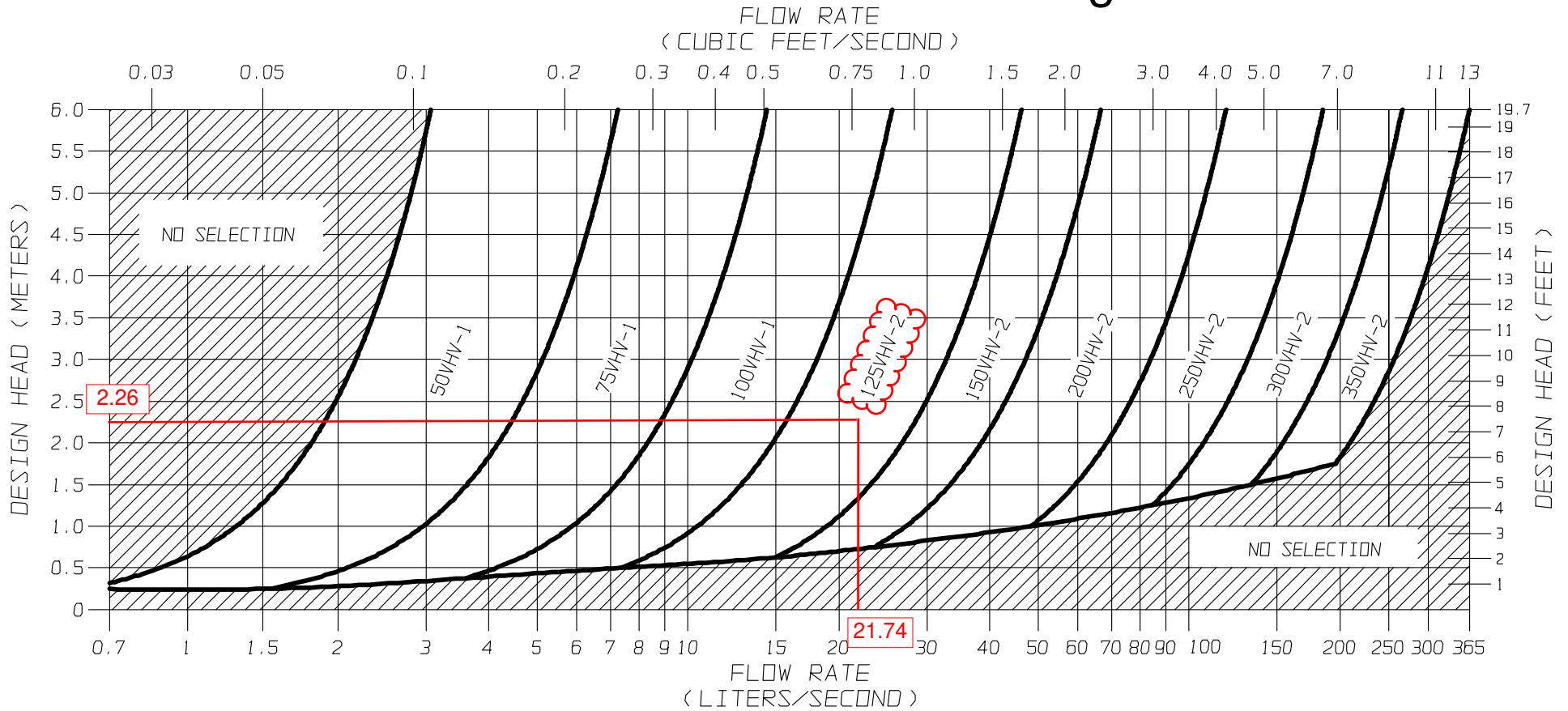

FIGURE 3 - VHV

**JOHN MEUNIER**



**FLOW REGULATOR TYPICAL INSTALLATION IN CIRCULAR MANHOLE  
FIGURE 4 (MODEL VHV)**

Model Number	Regulator Diameter		Minimum Manhole Diameter		Minimum Outlet Pipe Diameter		Minimum Clearance	
	A (mm)	A (in.)	B (mm)	B (in.)	C (mm)	C (in.)	H (mm)	H (in.)
50VHV-1	150	6	600	24	150	6	150	6
75VHV-1	250	10	600	24	150	6	150	6
100VHV-1	325	13	900	36	150	6	200	8
125VHV-2	275	11	900	36	150	6	200	8
150VHV-2	350	14	900	36	150	6	225	9
200VHV-2	450	18	1200	48	200	8	300	12
250VHV-2	575	23	1200	48	250	10	350	14
300VHV-2	675	27	1600	64	250	10	400	16
350VHV-2	800	32	1800	72	300	12	500	20

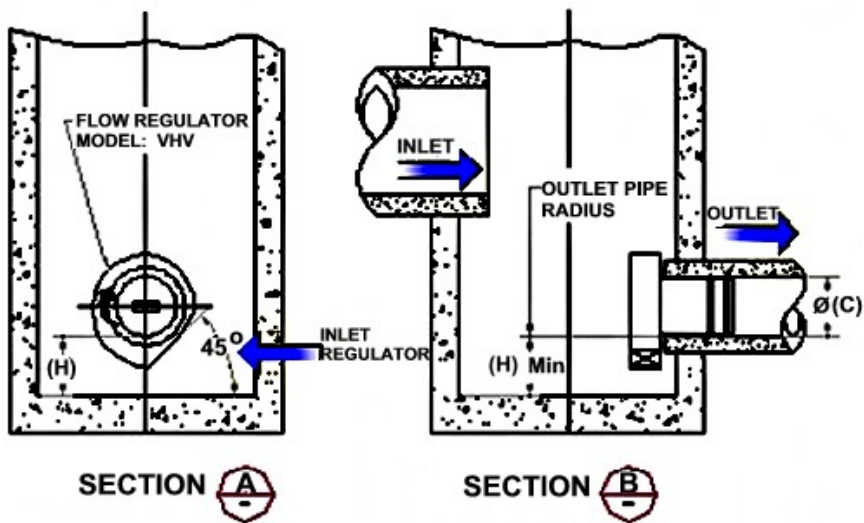
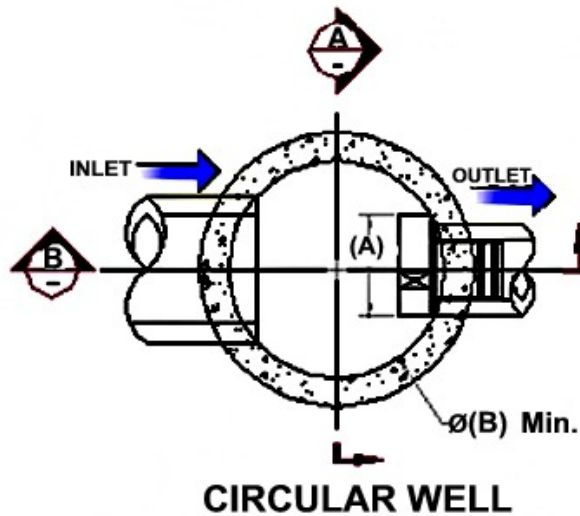

## INSTALLATION

The installation of a **HYDROVEX**<sup>®</sup> regulator may be undertaken once the manhole and piping is in place. Installation consists of simply fitting the regulator into the outlet pipe of the manhole. **John Meunier Inc.** recommends the use of a lubricant on the outlet pipe, in order to facilitate the insertion and orientation of the flow controller.

## MAINTENANCE

**HYDROVEX**<sup>®</sup> regulators are manufactured in such a way as to be maintenance free; however, a periodic inspection (every 3-6 months) is suggested in order to ensure that neither the inlet nor the outlet has become blocked with debris. The manhole should undergo periodically, particularly after major storms, inspection and cleaning as established by the municipality

## GUARANTY

The **HYDROVEX**<sup>®</sup> line of **VHV / SVHV** regulators are guaranteed against both design and manufacturing defects for a period of 5 years. Should a unit be defective, **John Meunier Inc.** is solely responsible for either modification or replacement of the unit.

### **John Meunier Inc.**

ISO 9001 : 2008

#### **Head Office**

4105 Sartelon

Saint-Laurent (Quebec) Canada H4S 2B3

Tel.: 514-334-7230 [www.johnmeunier.com](http://www.johnmeunier.com)

Fax: 514-334-5070 [cs@johnmeunier.com](mailto:cs@johnmeunier.com)

#### **Ontario Office**

2000 Argentia Road, Plaza 4, Unit 430

Mississauga (Ontario) Canada L5N 1W1

Tel.: 905-286-4846 [www.johnmeunier.com](http://www.johnmeunier.com)

Fax: 905-286-0488 [ontario@johnmeunier.com](mailto:ontario@johnmeunier.com)

#### **USA Office**

2209 Menlo Avenue

Glenside, PA USA 19038

Tel.: 412-417-6614 [www.johnmeunier.com](http://www.johnmeunier.com)

Fax: 215-885-4741 [astele@johnmeunier.com](mailto:astele@johnmeunier.com)

**APPENDIX E**  
**Civil Engineering Drawings**

# HALO CAR WASH 3535 BORRISOKANE RD BARRHAVEN, ON

## REVISION 01



KEY PLAN (N.T.S.)

DRAWING INDEX	
TITLE PAGE	
GENERAL NOTES	C000
SEDIMENT AND EROSION CONTROL PLAN	C101
DEMOLITION PLAN	C102
GRADING AND DRAINAGE PLAN	C301
SERVICING PLAN	C401
STORMWATER MANAGEMENT PLAN	C601
PRE-DEVELOPMENT WATERSHED PLAN	C701
POST-DEVELOPMENT WATERSHED PLAN	C702
CONSTRUCTION DETAIL PLAN	C901
CONSTRUCTION DETAIL PLAN	C902



# LRJ

ENGINEERING | INGÉNIERIE

5430 Canotek Road | Ottawa, ON, K1J 9G2  
www.lrl.ca | (613) 842-3434

**HALO CAR WASH**  
 3535 BORRISOKANE RD, BARRHAVEN, ON  
 REV.01 - ISSUED FOR APPROVAL - APRIL 22th 2022  
 LRL PROJECT no: 210691



NOT AUTHENTIC UNLESS SIGNED AND DATED



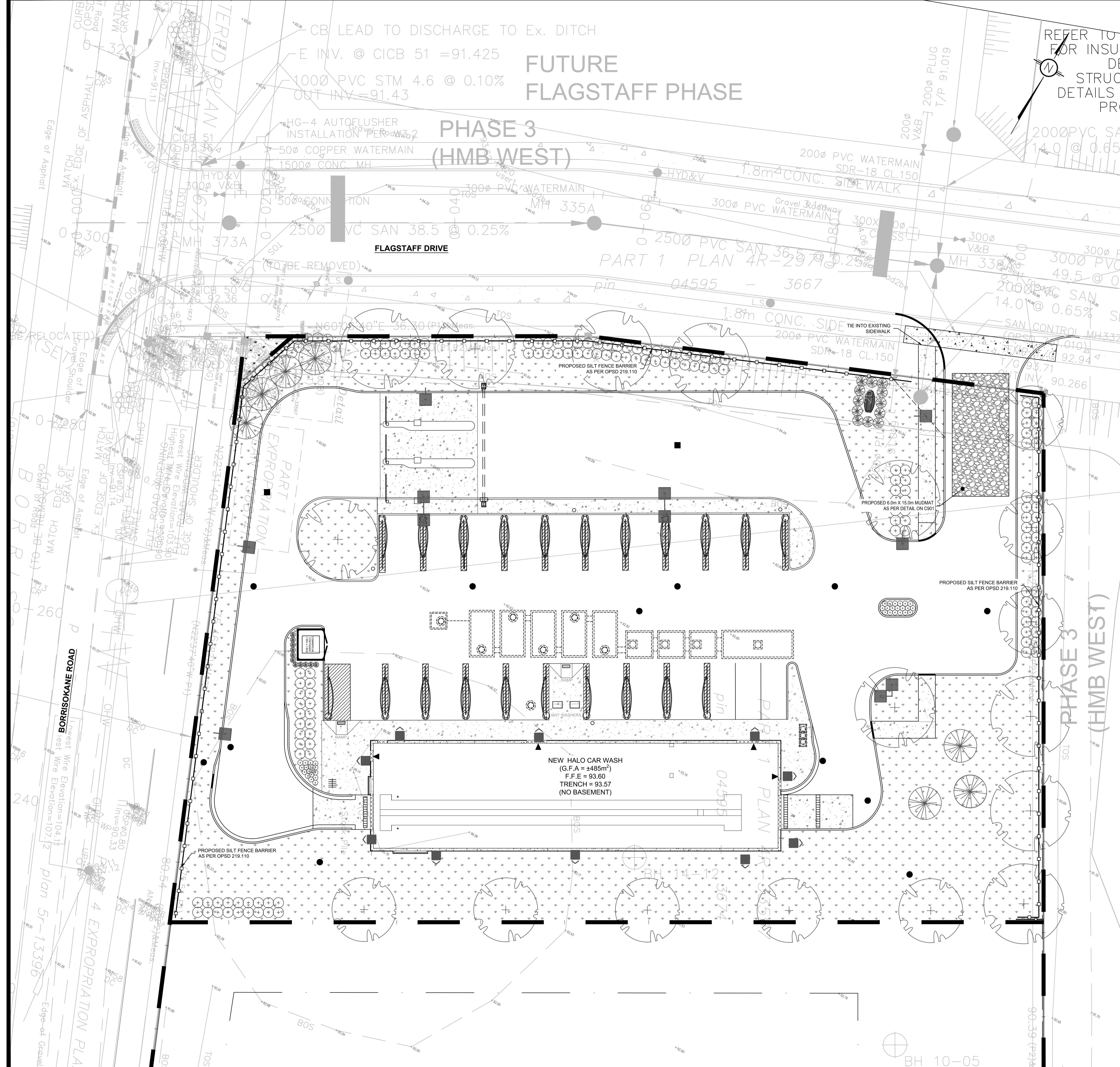

**LEGEND:**

	EXISTING PROPERTY LINE TO REMAIN
	PROPOSED CURB
	PROPOSED DEPRESSED CURB
	PROPOSED TERRACING (3:1 MIN.)
	PROPOSED SILT FENCE AS PER OPSD 219.110
	PROPOSED FENCE
	PROPOSED DOOR ENTRANCE/EXIST
	PROPOSED GRASS AREA (100mm TOP SOIL & SOD)
	PROPOSED CONCRETE FEATURES/SLAB
	PROPOSED HEAVY DUTY ASPHALT
	PROPOSED LIGHT DUTY ASPHALT
	PROPOSED RIP RAP
	PROPOSED ELEVATION
	PROPOSED HIGH POINT ELEVATION
	PROPOSED SLOPE ELEVATION
	PROPOSED BOTTOM OF CURB / ASPHALT ELEVATION
	PROPOSED TOP OF CURB ELEVATION
	PROPOSED EXPOSED BOTTOM OF RETAINING WALL
	PROPOSED TOP OF RETAINING WALL
	MATCH INTO EXISTING ELEVATION
	EXISTING ELEVATION
	PROPOSED OVERLAND MAJOR FLOW ROUTE
	PROPOSED 100mm Ø PERFORATED SUBDRAIN
	PROPOSED STORM SEWER
	PROPOSED SANITARY SEWER
	PROPOSED WATERMAIN
	EXISTING STORM SEWER
	EXISTING SANITARY SEWER
	EXISTING WATERMAIN
	EXISTING GAS LINE
	EXISTING MANHOLE
	EXISTING CATCHBASIN
	PROPOSED CATCHBASIN-MANHOLE/CATCHBASIN
	PROPOSED MANHOLE
	PROPOSED CURB STOP
	PROPOSED PIPE INSULATION
	PROPOSED 100 YEAR HIGH WATER LEVEL
	PROPOSED 5 YEAR HIGH WATER LEVEL
	STORM WATERSHED EXTENT
	WATERSHED NAME
	RUNOFF COEFFICIENT
	AREA IN HECTARES

**GENERAL CONDITIONS OF THE CONTRACT FOR CONSTRUCTION ARE PART OF THE CONTRACT DOCUMENTS AND DESCRIBE USE AND INTENT OF THE DRAWING. THE CONTRACTOR CONFIRMS THAT HE HAS VISITED THE SITE, FAMILIARIZED HIMSELF WITH THE LOCAL CONDITIONS, VERIFIED FIELD DIMENSIONS AND CORRELATED HIS OBSERVATIONS WITH THE CONTRACT DOCUMENTS.**

**BY USE OF THE DRAWINGS FOR CONSTRUCTION OF THE PROJECT, THE OWNER CONFIRMS THAT HE HAS REVIEWED AND APPROVED THE DRAWINGS. THE CONTRACTOR CONFIRMS THAT HE HAS VISITED THE SITE, FAMILIARIZED HIMSELF WITH THE LOCAL CONDITIONS, VERIFIED FIELD DIMENSIONS AND CORRELATED HIS OBSERVATIONS WITH THE CONTRACT DOCUMENTS.**

**AS INSTRUMENTS OF SERVICE, ALL DRAWINGS, SPECIFICATIONS, CAD FILES OR OTHER ELECTRONIC MEDIA AND COPIES THERE OF FURNISHED BY THE ENGINEER ARE HIS PROPERTY. THEY ARE TO BE USED ONLY FOR THIS PROJECT AND ARE NOT TO BE USED ON ANY OTHER PROJECT, INCLUDING REPEATS OF THE PROJECT. CHANGES TO THE DRAWINGS MAY ONLY BE MADE BY THE ENGINEER.**

**UNLESS THE REVISION TITLE IS ISSUED FOR CONSTRUCTION, THESE DRAWINGS SHALL BE CONSIDERED PRELIMINARY AND SHALL NOT BE USED AS A CONSTRUCTION DOCUMENT.**

**THESE DRAWINGS ILLUSTRATE THE WORK TO BE DONE. THE ENGINEER IS NOT RESPONSIBLE FOR THE MEANS, METHODS, TECHNIQUES, SEQUENCES, AND PROCEDURES USED TO DO THE WORK, OR THE SAFETY ASPECTS OF CONSTRUCTION, AND NOTHING ON THESE DRAWINGS EXPRESSED OR IMPLIED CHANGES THIS CONDITION. CONTRACTOR SHALL DETERMINE ALL CONDITIONS AT THE SITE AND SHALL BE RESPONSIBLE FOR KNOWING HOW THEY AFFECT THE WORK. SUBMITTAL OF A BID TO PERFORM THIS WORK IS AN ACKNOWLEDGEMENT OF THE RESPONSIBILITIES, AND THAT THEY HAVE BEEN FULLY CONSIDERED IN PLANNING OF THE WORK AND THE BID PRICE. NO CLAIMS FOR EXTRA CHARGES DUE TO THESE CONDITIONS WILL BE FORTHCOMING.**

**UNAUTHORIZED CHANGES:**

**IN THE EVENT THE CLIENT, THE CLIENT'S CONTRACTORS OR SUBCONTRACTORS, OR ANYONE FOR WHOM THE CLIENT IS LEGALLY LIABLE MAKES OR PERMITS TO BE MADE ANY CHANGES TO ANY PARTS, DETAILS, SPECIFICATIONS OR OTHER CONSTRUCTION DOCUMENTS PREPARED BY LRI ASSOCIATES LTD. (LRI) WITHOUT OBTAINING LRI'S PRIOR WRITTEN CONSENT, THE CLIENT SHALL ASSUME FULL RESPONSIBILITY FOR THE RESULTS OF SUCH CHANGES. THEREFORE THE CLIENT AGREES TO WAIVE ANY CLAIM AGAINST LRI AND TO RELEASE LRI FROM ANY LIABILITY ARISING DIRECTLY OR INDIRECTLY FROM SUCH UNAUTHORIZED CHANGES.**

**IN ADDITION, THE CLIENT AGREES TO THE FULLEST EXTENT PERMITTED BY LAW, TO INDEMNIFY AND HOLD HARMLESS LRI FROM ANY DAMAGES, LIABILITIES OR COSTS, INCLUDING REASONABLE ATTORNEY'S FEES AND COST OF DEFENSE, ARISING FROM SUCH CHANGES.**

**IN ADDITION, THE CLIENT AGREES TO INCLUDE IN ANY CONTRACTS FOR CONSTRUCTION APPROPRIATE LANGUAGE THAT PROHIBITS THE CONTRACTOR OR ANY SUBCONTRACTORS OF ANY TIER FROM MAKING ANY CHANGES OR MODIFICATIONS TO LRI'S CONSTRUCTION DOCUMENTS WITHOUT THE PRIOR WRITTEN APPROVAL OF LRI AND THAT FURTHER REQUIRES THE CONTRACTOR TO INDEMNIFY BOTH LRI AND THE CLIENT FROM ANY LIABILITY OR COST ARISING FROM SUCH CHANGES MADE WITHOUT SUCH PROPER AUTHORIZATION.**

**GENERAL NOTES:**

**EXISTING SERVICES AND UTILITIES SHOWN ON THESE DRAWINGS ARE TAKEN FROM THE BEST AVAILABLE RECORDS, BUT MAY NOT BE COMPLETE OR TO DATE. CONTRACTOR SHALL VERIFY IN FIELD FOR LOCATION AND ELEVATION OF PIPES AND CHECK WITH THE UTILITY COMPANIES BEFORE DIGGING OR PERFORMING WORK.**

**CONTRACTOR IS ADVISED TO COLLECT INFORMATION ON SOIL CONDITIONS BEFORE START OF CONSTRUCTION.**

**THE ENGINEER WAIVES ANY AND ALL RESPONSIBILITY AND LIABILITY FOR PROBLEMS WHICH ARISE FROM FAILURE TO FOLLOW THESE PLANS, SPECIFICATIONS AND TO LRI'S CONSTRUCTION DOCUMENTS WITHOUT THE PRIOR WRITTEN APPROVAL OF LRI AND THAT FURTHER REQUIRES THE CONTRACTOR TO INDEMNIFY BOTH LRI AND THE CLIENT FROM ANY LIABILITY OR COST ARISING FROM SUCH CHANGES MADE WITHOUT SUCH PROPER AUTHORIZATION.**

**CONTRACTOR TO VERIFY ALL DIMENSIONS AND NOTIFY THE ENGINEER OF ANY DISCREPANCIES BEFORE WORK COMMENCES. DO NOT SCALE DRAWINGS.**

BY STRUC  
1200x900  
CULVERT  
THICKNES  
@ 0.10%  
IN INV=  
OUT INV=

200-300m  
RIP-RAP S  
0.60m P  
TOP OF P  
270R F  
OR EQUIV

04595 -  
3674 -  
MATCH

01 ISSUED FOR APPROVAL M.L. 22 APR 2022

No.	REVISIONS	BY	DATE

**PROFESSIONAL ENGINEER**  
M. BASNET  
100501996  
2022/04/22  
PROVINCE OF ONTARIO

NOT AUTHENTIC UNLESS SIGNED AND DATED

**LRJ**  
ENGINEERING | INGÉNIÉRIE  
5430 Canotek Road | Ottawa, ON, K1J 9G2  
www.lri.ca | (613) 842-3434

CLIENT  
**HALO CAR WASH INC.**

DESIGNED BY:	DRAWN BY:	APPROVED BY:
M.L. / P.P.	M.L.	M.B.

PROJECT  
**HALO CAR WASH**  
3535 BORRISOKANE RD  
BARRHAVEN, ON

DRAWING TITLE  
**EROSION AND SEDIMENT CONTROL PLAN**

PROJECT NO.  
210691

DATE  
JANUARY 2022

**C101**

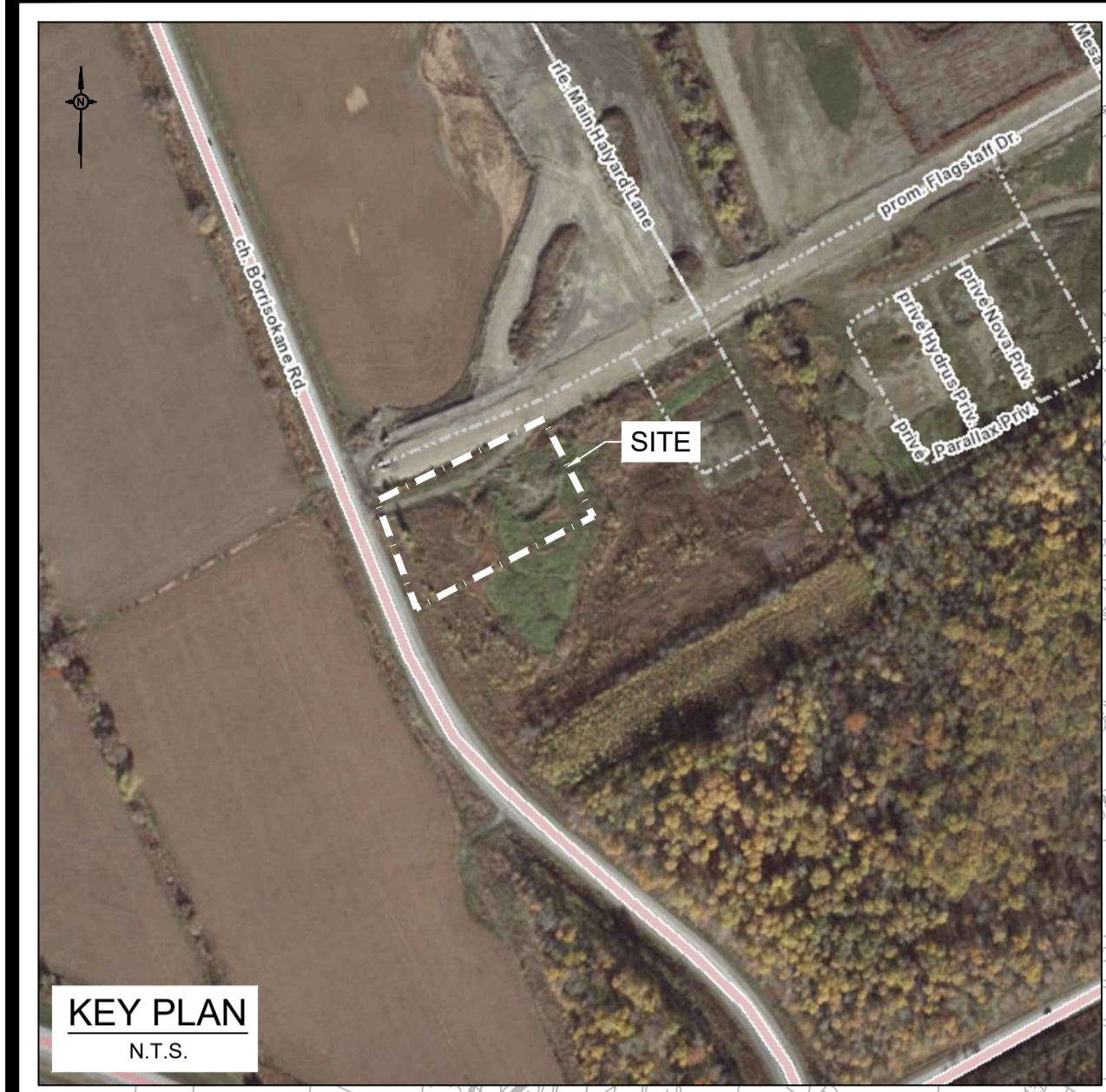

**KEY PLAN**  
N.T.S.

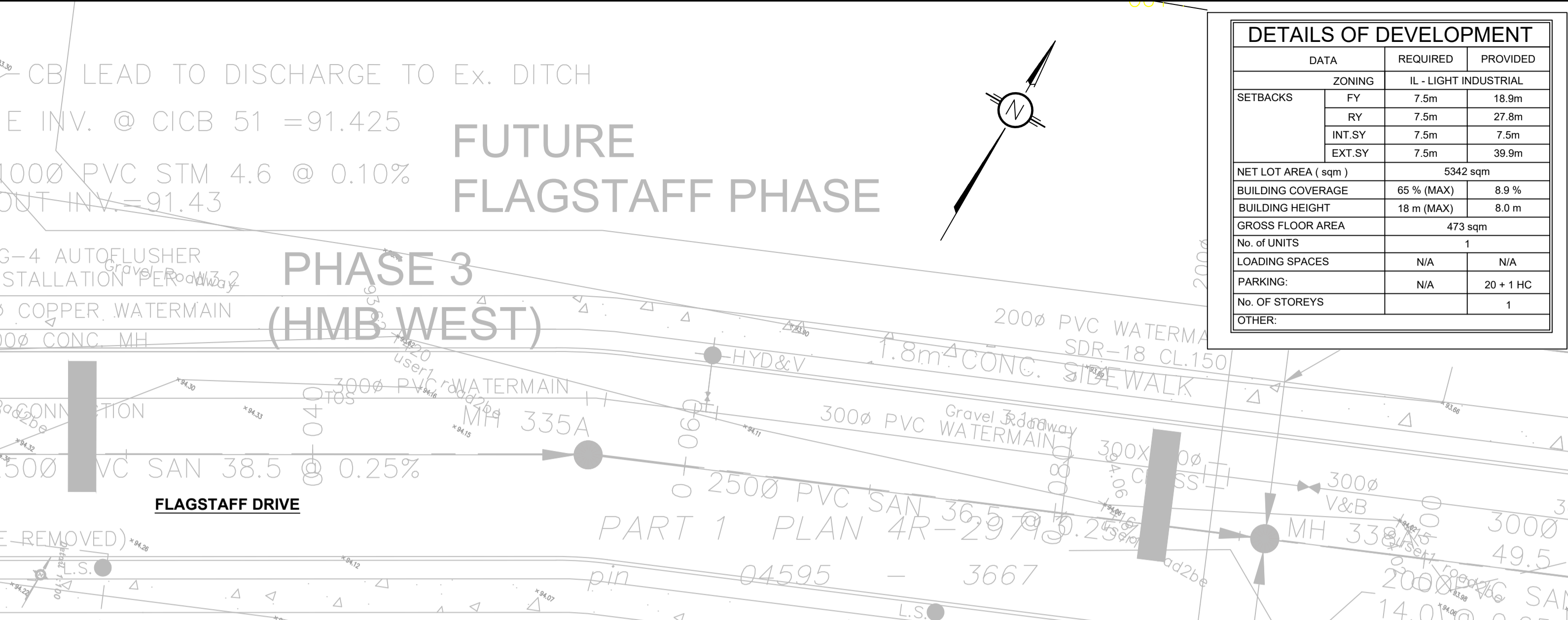

DETAILS OF DEVELOPMENT		
DATA	REQUIRED	PROVIDED
ZONING	IL - LIGHT INDUSTRIAL	
SETBACKS		
FY	7.5m	18.9m
RY	7.5m	27.8m
INT.SY	7.5m	7.5m
EXT.SY	7.5m	39.9m
NET LOT AREA (sqm)	5342 sqm	
BUILDING COVERAGE	65% (MAX)	8.9%
BUILDING HEIGHT	18 m (MAX)	8.0 m
GROSS FLOOR AREA		473 sqm
No. OF UNITS		1
LOADING SPACES	N/A	N/A
PARKING:	N/A	20 + 1 HC
No. OF STOREYS		1
OTHER:		

LEGEND:	
	EXISTING PROPERTY LINE TO REMAIN
	PROPOSED CURB
	PROPOSED DEPRESSED CURB
	PROPOSED TERRACING (3:1 MIN.)
	PROPOSED SILT FENCE AS PER OPSD 219.110
	PROPOSED FENCE
	PROPOSED DOOR ENTRANCE/EXIT
	PROPOSED GRASS AREA (100mm TOP SOIL & SOD)
	PROPOSED CONCRETE FEATURES/SLAB
	PROPOSED HEAVY DUTY ASPHALT
	PROPOSED LIGHT DUTY ASPHALT
	PROPOSED RIP RAP
	PROPOSED ELEVATION
	PROPOSED HIGH POINT ELEVATION
	PROPOSED SWALE ELEVATION
	PROPOSED BOTTOM OF CURB / ASPHALT ELEVATION
	PROPOSED TOP OF CURB ELEVATION
	PROPOSED EXPOSED BOTTOM OF RETAINING WALL
	PROPOSED TOP OF RETAINING WALL
	MATCH INTO EXISTING ELEVATION
	EXISTING ELEVATION
	PROPOSED OVERLAND MAJOR FLOW ROUTE
	PROPOSED 100mm PERFORATED SUBDRAIN
	PROPOSED STORM SEWER
	PROPOSED SANITARY SEWER
	PROPOSED WATERMAIN
	EXISTING STORM SEWER
	EXISTING SANITARY SEWER
	EXISTING WATERMAIN
	EXISTING GAS LINE
	EXISTING MANHOLE
	EXISTING CATCHBASIN
	PROPOSED CATCHBASIN-MANHOLE/CATCHBASIN
	PROPOSED MANHOLE
	PROPOSED CURB STOP
	PROPOSED PIPE INSULATION
	PROPOSED 100 YEAR HIGH WATER LEVEL
	PROPOSED 5 YEAR HIGH WATER LEVEL
	STORM WATERSHED EXTENT
	WATERSHED NAME
	RUNOFF COEFFICIENT
	AREA IN HECTARES

**GENERAL CONDITIONS OF DRAWINGS**

GENERAL CONDITIONS OF THE CONTRACT FOR CONSTRUCTION ARE PART OF THE CONTRACT DOCUMENTS AND DESCRIBE USE AND INTENT OF THE DRAWING. THE CONTRACT DOCUMENTS INCLUDE NOT ONLY THE DRAWINGS, BUT ALSO THE SPECIFICATIONS, ADDENDUMS, AND MODIFICATIONS ISSUED AFTER EXECUTION OF THE CONTRACT. THESE CONTRACT DOCUMENTS ARE COMPLEMENTARY, AND WHAT IS REQUIRED BY ANY ONE SHALL BE BINDING AS REQUIRED BY ALL. WORK NOT COMPLETELY DELINEATED HEREON SHALL BE CONSTRUCTED OF THE SAME MATERIALS AND DETAILS SIMILARLY AS WORK SHOWN MORE COMPLETELY ELSEWHERE IN THE CONTRACT DOCUMENTS.

BY USE OF THE DRAWINGS FOR CONSTRUCTION OF THE PROJECT, THE OWNER CONFIRMS THAT HE HAS REVIEWED AND APPROVED THE DRAWINGS. THE CONTRACTOR CONFIRMS THAT HE HAS VISITED THE SITE, FAMILIARIZED HIMSELF WITH THE LOCAL CONDITIONS, VERIFIED FIELD DIMENSIONS AND CORRELATED HIS OBSERVATIONS WITH THE DETAILS OF THE CONTRACT DOCUMENTS.

AS INSTRUMENTS OF SERVICE, ALL DRAWINGS, SPECIFICATIONS, CAD FILES OR OTHER ELECTRONIC MEDIA AND COPIES THERE OF FURNISHED BY THE ENGINEER ARE HIS PROPERTY. THEY ARE TO BE USED ONLY FOR THE PROJECT AND ARE NOT TO BE USED ON ANY OTHER PROJECT, INCLUDING REPEATS OF THE PROJECT. CHANGES TO THE DRAWINGS MAY ONLY BE MADE BY THE ENGINEER.

UNLESS THE REVISION TITLE IS ISSUED FOR CONSTRUCTION, THESE DRAWINGS SHALL BE CONSIDERED PRELIMINARY AND SHALL NOT BE USED AS A CONSTRUCTION DOCUMENT.

THESE DRAWINGS ILLUSTRATE THE WORK TO BE DONE. THE ENGINEER IS NOT RESPONSIBLE FOR THE MEANS, METHODS, TECHNIQUES, SEQUENCES, AND PROCEDURES USED TO DO THE WORK, OR THE SAFETY ASPECTS OF CONSTRUCTION, AND NOTHING ON THESE DRAWINGS EXPRESSED OR IMPLIED CHANGES THIS CONDITION. CONTRACTOR SHALL DETERMINE ALL CONDITIONS AT THE SITE AND SHALL BE RESPONSIBLE FOR KNOWING HOW THEY AFFECT THE WORK. SUBMITTALS OR A BIDDING TO PERFORM THIS WORK IS ACKNOWLEDGMENT OF THE RESPONSIBILITIES, AND THAT THEY HAVE BEEN FULLY CONSIDERED IN PLANNING OF THE WORK AND THE BID PRICE. NO CLAIMS FOR EXTRA CHARGES DUE TO THESE CONDITIONS WILL BE FORTHCOMING.

**UNAUTHORIZED CHANGES:**

IN THE EVENT THE CLIENT, THE CLIENT'S CONTRACTORS OR SUBCONTRACTORS, OR ANYONE FOR WHOM THE CLIENT IS LEGALLY LIABLE MAKES OR PERMITS TO BE MADE ANY CHANGES TO ANY REPORTS, PLANS, SPECIFICATIONS OR OTHER CONSTRUCTION DOCUMENTS PREPARED BY LRL ASSOCIATES LTD. (LRL) WITHOUT OBTAINING LRL'S PRIOR WRITTEN CONSENT, THE CLIENT SHALL ASSUME FULL RESPONSIBILITY FOR THE RESULTS OF SUCH CHANGES. THEREFORE THE CLIENT AGREES TO WAIVE ANY CLAIM AGAINST LRL AND TO RELEASE LRL FROM ANY LIABILITY ARISING DIRECTLY OR INDIRECTLY FROM SUCH UNAUTHORIZED CHANGES.

IN ADDITION, THE CLIENT AGREES, TO THE FULLEST EXTENT PERMITTED BY LAW, TO INDEMNIFY AND HOLD HARMLESS LRL FROM ANY DAMAGES, LIABILITIES OR COSTS, INCLUDING REASONABLE ATTORNEY'S FEES AND COST OF DEFENSE, ARISING FROM SUCH CHANGES.

IN ADDITION, THE CLIENT AGREES TO INCLUDE IN ANY CONTRACTS FOR CONSTRUCTION APPROPRIATE LANGUAGE THAT PROHIBITS THE CONTRACTOR OR ANY SUBCONTRACTORS OF ANY TIER FROM MAKING ANY CHANGES OR MODIFICATIONS TO LRL'S CONSTRUCTION DOCUMENTS WITHOUT THE PRIOR WRITTEN APPROVAL OF LRL AND THAT FURTHER REQUIRES THE CONTRACTOR TO INDEMNIFY BOTH LRL AND THE CLIENT FROM ANY LIABILITY OR COST ARISING FROM SUCH CHANGES MADE WITHOUT SUCH PROPER AUTHORIZATION.

**GENERAL NOTES:**

EXISTING SERVICES AND UTILITIES SHOWN ON THESE DRAWINGS ARE TAKEN FROM THE BEST AVAILABLE RECORDS, BUT MAY NOT BE COMPLETE OR TO DATE. CONTRACTOR SHALL VERIFY IN FIELD FOR THIS WORK AND ELEVATION OF PIPES AND CHECK WITH THE UTILITY COMPANIES BEFORE DIGGING OR PERFORMING WORK.

CONTRACTOR IS ADVISED TO COLLECT INFORMATION ON SOIL CONDITIONS BEFORE START OF CONSTRUCTION.

THE ENGINEER WAIVES ANY AND ALL RESPONSIBILITY AND LIABILITY FOR PROBLEMS WHICH ARISE FROM FAILURE TO FOLLOW THESE PLANS, SPECIFICATIONS AND THE DESIGN INTENT. THE ENGINEER SHALL ASSUME NO RESPONSIBILITY FOR OTHERS' FAILURE TO OBTAIN AND/OR FOLLOW THE ENGINEER'S GUIDANCE WITH RESPECT TO ANY TIERING, OMISSIONS, INCONSISTENCIES, AMBIGUITIES OR CONFLICTS WHICH ARE ALLEGED.

CONTRACTOR TO VERIFY ALL DIMENSIONS AND NOTIFY THE ENGINEER OF ANY DISCREPANCIES BEFORE WORK COMMENCES. DO NOT SCALE DRAWINGS.

SCALE: 1:200

**NOT FOR CONSTRUCTION TENDER OR PERMIT**

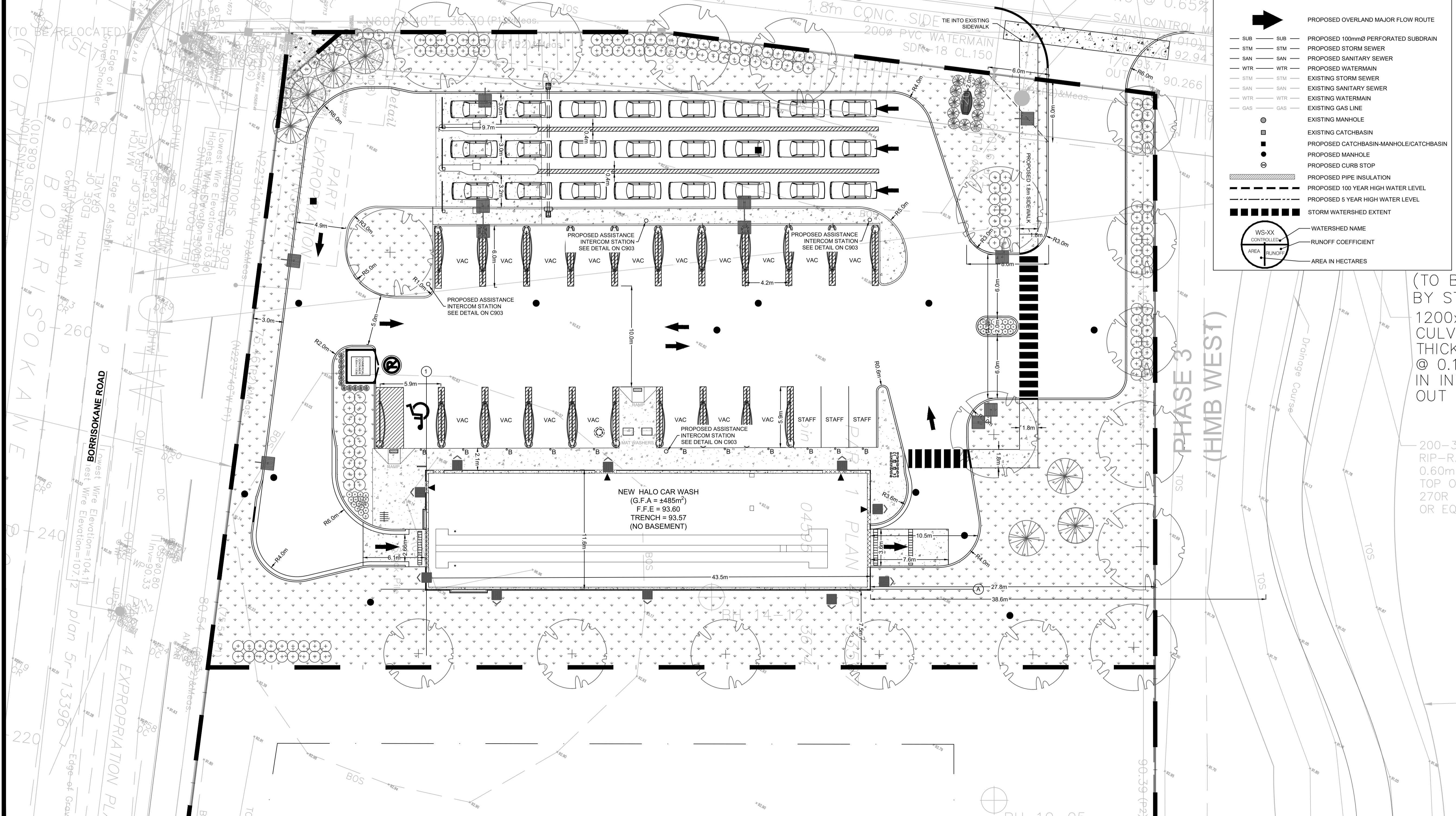

NO.	ISSUED FOR APPROVAL	M.L.	22 APR 2022
	REVISIONS	BY	DATE



CLIENT: HALO CAR WASH INC.

DESIGNED BY: M.L. / P.P. DRAWN BY: M.L. APPROVED BY: M.B.

PROJECT: HALO CAR WASH  
3535 BORRISOKANE RD  
BARRHAVEN, ON

DRAWING TITLE: SITE DEVELOPMENT PLAN

PROJECT NO: 210691

DATE: JANUARY 2022

**C201**

**PAVEMENT STRUCTURE**

COURSE	MATERIAL	THICKNESS (mm)	
		AUTOMOBILE PARKING	TRUCK ROUTE (HEAVY TRAFFIC)
SURFACE	HL.3 A/C (PG 58-28)	50	40
BINDER	HL.8 A/C (PG 58-28)	-	50
BASECOURSE	OPSS GRANULAR "A"	150	150
SUBBASE	OPSS GRANULAR "B" TYPE II	350	450

NOTE: IN PREPARATION FOR PAVEMENT CONSTRUCTION AT THIS SITE, ANY SURFICIAL OR NEAR SURFACE/SUBGRADE LEVEL TOPSOIL AND ANY SOFT, WET OR DELETERIOUS MATERIALS SHOULD BE REMOVED FROM THE PROPOSED PAVED AREAS. THE EXPOSED SUBGRADE SHOULD BE INSPECTED AND APPROVED BY GEOTECHNICAL PERSONNEL AND ANY SOFT AREAS EVIDENT SHOULD BE SUBEXCAVATED AND REPLACED WITH SUITABLE EARTH BORROW APPROVED BY THE GEOTECHNICAL ENGINEER. THE SUBGRADE SHOULD BE SHAPED AND CROWNED TO PROMOTE DRAINAGE OF THE SITE DRAINAGE STRUCTURES. FOLLOWING APPROVAL OF THE SUBGRADE, THE PAVEMENT GRANULARS MAY BE PLACED.

**LEGEND:**

- EXISTING PROPERTY LINE TO REMAIN
- PROPOSED CURB
- PROPOSED DEPRESSED CURB
- PROPOSED TERRACING (3:1 MIN.)
- PROPOSED SILT FENCE AS PER OPSD 219.110
- PROPOSED FENCE
- PROPOSED DOOR ENTRANCE/EXIST
- PROPOSED GRASS AREA (100mm TOP SOIL & SOD)
- PROPOSED CONCRETE FEATURES/SLAB
- PROPOSED HEAVY DUTY ASPHALT
- PROPOSED LIGHT DUTY ASPHALT
- PROPOSED RIP RAP
- PROPOSED ELEVATION
- PROPOSED HIGH POINT ELEVATION
- PROPOSED SWALE ELEVATION
- PROPOSED BOTTOM OF CURB / ASPHALT ELEVATION
- PROPOSED TOP OF CURB ELEVATION
- PROPOSED EXPOSED BOTTOM OF RETAINING WALL
- PROPOSED TOP OF RETAINING WALL
- MATCH INTO EXISTING ELEVATION
- EXISTING ELEVATION
- PROPOSED OVERLAND MAJOR FLOW ROUTE
- PROPOSED 100mm Ø PERFORATED SUBDRAIN
- PROPOSED STORM SEWER
- PROPOSED SANITARY SEWER
- PROPOSED WATERMAIN
- EXISTING STORM SEWER
- EXISTING SANITARY SEWER
- EXISTING WATERMAIN
- EXISTING GAS LINE
- EXISTING MANHOLE
- EXISTING CATCHBASIN
- PROPOSED CATCHBASIN-MANHOLE/CATCHBASIN
- PROPOSED MANHOLE
- PROPOSED CURB STOP
- PROPOSED PIPE INSULATION
- PROPOSED 100 YEAR HIGH WATER LEVEL
- PROPOSED 5 YEAR HIGH WATER LEVEL
- STORM WATERSHED EXTENT
- WATERSHED NAME
- RUNOFF COEFFICIENT
- AREA IN HECTARES

**USE AND INTERPRETATION OF DRAWINGS**

GENERAL CONDITIONS OF THE CONTRACT FOR CONSTRUCTION ARE PART OF THE CONTRACT DOCUMENTS AND DESCRIBE USE AND INTENT OF THE DRAWING. THE CONTRACTOR SHALL BE RESPONSIBLE FOR OBTAINING ALL NECESSARY PERMITS AND APPROVALS FROM THE LOCAL AUTHORITY. THE CONTRACTOR SHALL BE RESPONSIBLE FOR OBTAINING ALL NECESSARY PERMITS AND APPROVALS FROM THE LOCAL AUTHORITY. THE CONTRACTOR SHALL BE RESPONSIBLE FOR OBTAINING ALL NECESSARY PERMITS AND APPROVALS FROM THE LOCAL AUTHORITY.

BY USE OF THE DRAWINGS FOR CONSTRUCTION OF THE PROJECT, THE OWNER AGREES TO WAIVE ANY CLAIM AGAINST LRI AND TO RELEASE LRI FROM ANY LIABILITY ARISING DIRECTLY OR INDIRECTLY FROM SUCH UNAUTHORIZED CHANGES.

IN ADDITION, THE CLIENT AGREES TO INCLUDE IN ANY CONTRACTS FOR CONSTRUCTION APPROPRIATE LANGUAGE THAT PROHIBITS THE CONTRACTOR OR ANY SUBCONTRACTORS OF ANY TIER FROM MAKING ANY CHANGES OR MODIFICATIONS TO LRI'S CONSTRUCTION DOCUMENTS WITHOUT THE PRIOR WRITTEN APPROVAL OF LRI AND THAT FURTHER REQUIRES THE CONTRACTOR TO INDEMNIFY BOTH LRI AND THE CLIENT FROM ANY LIABILITY OR COST ARISING FROM SUCH CHANGES MADE WITHOUT SUCH PROPER AUTHORIZATION.

**GENERAL NOTES:**

EXISTING SERVICES AND UTILITIES SHOWN ON THESE DRAWINGS ARE TAKEN FROM THE BEST AVAILABLE RECORDS, BUT MAY NOT BE COMPLETE OR TO DATE. CONTRACTOR SHALL VERIFY IN FIELD FOR LOCATION AND ELEVATION OF PIPES AND CHECK WITH THE UTILITY COMPANIES BEFORE DIGGING OR PERFORMING WORK.

CONTRACTOR IS ADVISED TO COLLECT INFORMATION ON SOIL CONDITIONS BEFORE START OF CONSTRUCTION.

THE ENGINEER WAIVES ANY AND ALL RESPONSIBILITY AND LIABILITY FOR PROBLEMS WHICH ARISE FROM FAILURE TO FOLLOW THESE PLANS, SPECIFICATIONS AND CONDITIONS. THE CLIENT SHALL ASSUME FULL RESPONSIBILITY FOR THE RESULTS OF SUCH CHANGES. THEREFORE THE CLIENT AGREES TO WAIVE ANY CLAIM AGAINST LRI AND TO RELEASE LRI FROM ANY LIABILITY ARISING DIRECTLY OR INDIRECTLY FROM SUCH UNAUTHORIZED CHANGES.

CONTRACTOR TO VERIFY ALL DIMENSIONS AND NOTIFY THE ENGINEER OF ANY DISCREPANCIES BEFORE WORK COMMENCES. DO NOT SCALE DRAWINGS.

SCALE: 1:200

**NOT FOR CONSTRUCTION TENDER OR PERMIT**

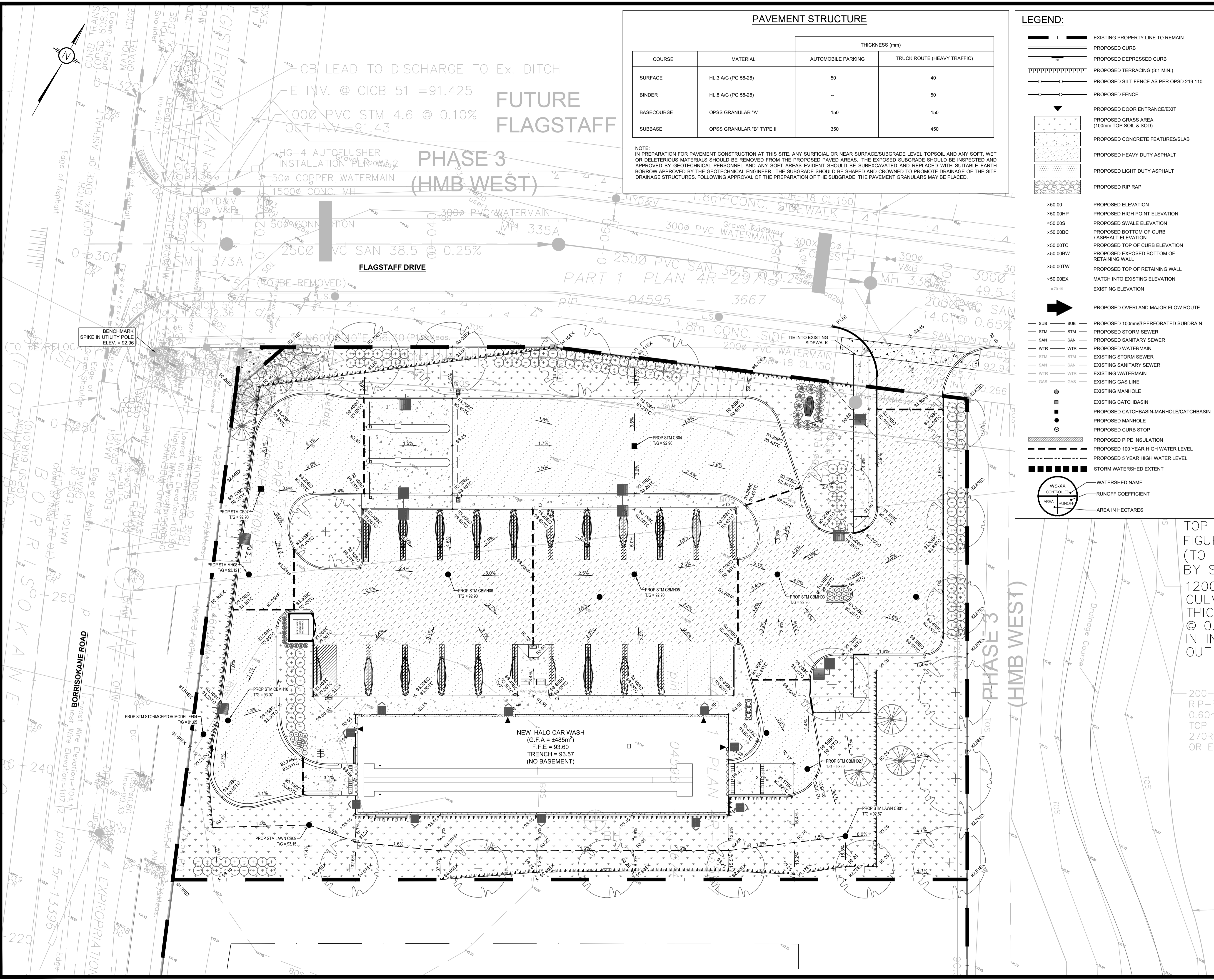

TOP FIGURE (TO BE BY S 1200 CULV THICK @ 0.1 IN IN OUT

200-RIP-R 0.60m TOP OF 270R OR EQ

01	ISSUED FOR APPROVAL	M.L.	22 APR 2022
No.	REVISIONS	BY	DATE

**PROFESSIONAL ENGINEER**  
M. BASNET  
100501996  
2022/04/22  
PROVINCE OF ONTARIO

NOT AUTHENTIC UNLESS SIGNED AND DATED

**LRJ**  
ENGINEERING | INGÉNIERIE  
5430 Canotek Road | Ottawa, ON, K1J 9G2  
www.lri.ca | (613) 842-3434

CLIENT: **HALO CAR WASH INC.**

DESIGNED BY: M.L. / P.P.    DRAWN BY: M.L.    APPROVED BY: M.B.

PROJECT: **HALO CAR WASH  
3535 BORRISOKANE RD  
BARRHAVEN, ON**

DRAWING TITLE: **GRADING AND DRAINAGE PLAN**

PROJECT NO: 210691    DATE: JANUARY 2022

**C301**



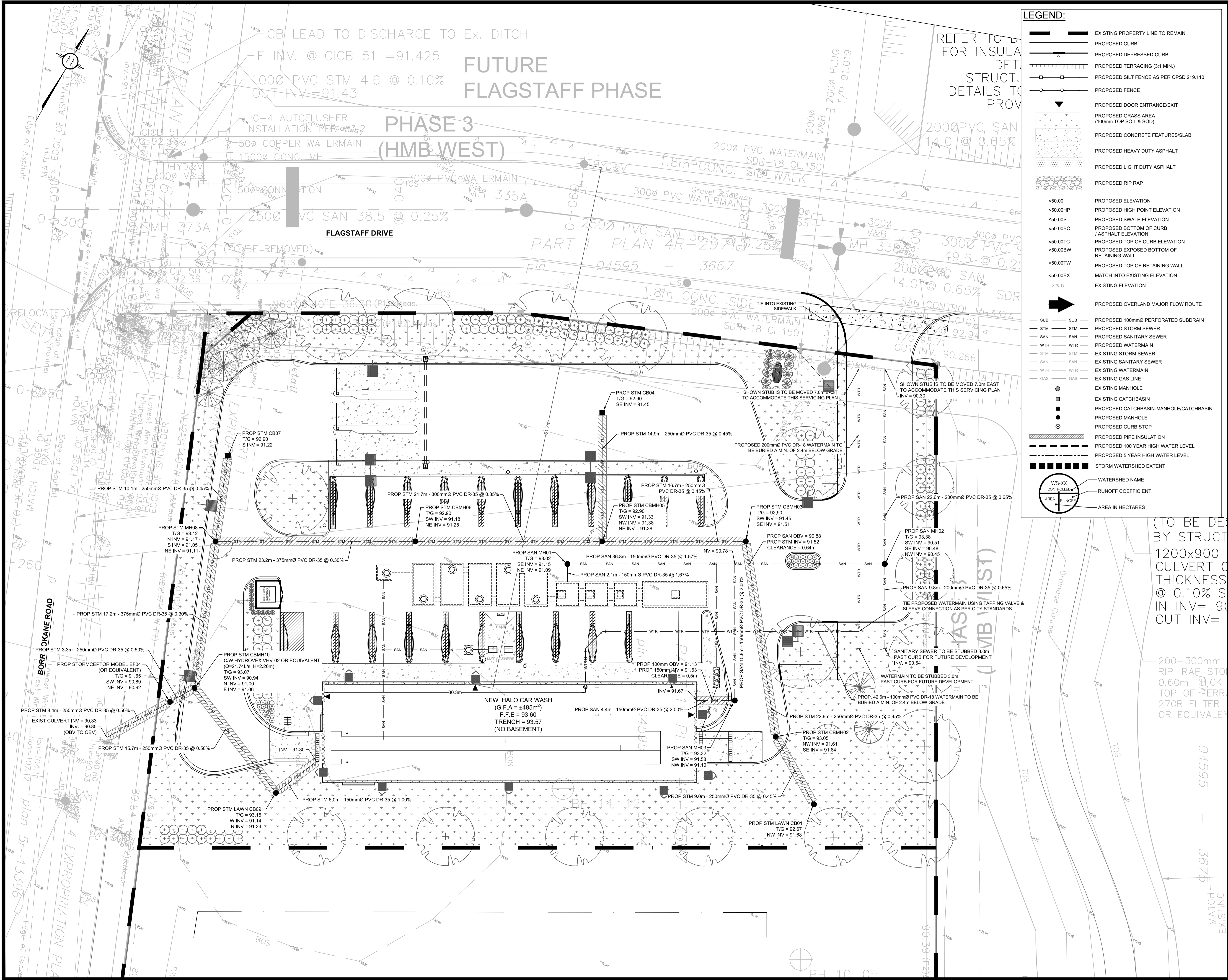

**LEGEND:**

	EXISTING PROPERTY LINE TO REMAIN
	PROPOSED CURB
	PROPOSED DEPRESSED CURB
	PROPOSED TERRACING (3:1 MIN)
	PROPOSED SILT FENCE AS PER OPSD 219.110
	PROPOSED FENCE
	PROPOSED DOOR ENTRANCE/EXIT
	PROPOSED GRASS AREA (100mm TOP SOIL & SOD)
	PROPOSED CONCRETE FEATURES/SLAB
	PROPOSED HEAVY DUTY ASPHALT
	PROPOSED LIGHT DUTY ASPHALT
	PROPOSED RIP RAP
	PROPOSED ELEVATION
	PROPOSED HIGH POINT ELEVATION
	PROPOSED SWALE ELEVATION
	PROPOSED BOTTOM OF CURB / ASPHALT ELEVATION
	PROPOSED TOP OF CURB ELEVATION
	PROPOSED EXPOSED BOTTOM OF RETAINING WALL
	PROPOSED TOP OF RETAINING WALL
	MATCH INTO EXISTING ELEVATION
	EXISTING ELEVATION
	PROPOSED OVERLAIN MAJOR FLOW ROUTE
	PROPOSED 100mm PERFORATED SUBDRAIN
	PROPOSED STORM SEWER
	PROPOSED SANITARY SEWER
	PROPOSED WATERMAIN
	EXISTING STORM SEWER
	EXISTING SANITARY SEWER
	EXISTING WATERMAIN
	EXISTING GAS LINE
	EXISTING MANHOLE
	EXISTING CATCHBASIN
	PROPOSED CATCHBASIN-MANHOLE/CATCHBASIN
	PROPOSED MANHOLE
	PROPOSED CURB STOP
	PROPOSED PIPE INSULATION
	PROPOSED 100 YEAR HIGH WATER LEVEL
	PROPOSED 5 YEAR HIGH WATER LEVEL
	STORM WATERSHED EXTENT
	WATERSHED NAME
	RUNOFF COEFFICIENT
	AREA IN HECTARES

**GENERAL CONDITIONS OF THE CONTRACT FOR CONSTRUCTION ARE PART OF THE CONTRACT DOCUMENTS AND DESCRIBE USE AND INTENT OF THE DRAWING. THE CONTRACTOR SHALL VERIFY IN FIELD FOR LOCATION AND ELEVATION OF PIPES AND CHECK WITH THE UTILITY COMPANIES BEFORE DIGGING OR PERFORMING WORK.**

**UNAUTHORIZED CHANGES:**  
 IN THE EVENT THE CLIENT, THE CLIENT'S CONTRACTORS OR SUBCONTRACTORS, OR ANYONE FOR WHOM THE CLIENT IS LEGALLY LIABLE MAKES OR PERMITS TO BE MADE ANY CHANGES TO THESE PLANS, SPECIFICATIONS OR OTHER CONSTRUCTION DOCUMENTS PREPARED BY LRI ASSOCIATES LTD. (LRI) WITHOUT OBTAINING LRI'S PRIOR WRITTEN CONSENT, THE CLIENT SHALL ASSUME FULL RESPONSIBILITY FOR THE RESULTS OF SUCH CHANGES. THEREFORE THE CLIENT AGREES TO WAIVE ANY CLAIM AGAINST LRI AND TO RELEASE LRI FROM ANY LIABILITY ARISING DIRECTLY OR INDIRECTLY FROM SUCH UNAUTHORIZED CHANGES.

**IN ADDITION, THE CLIENT AGREES TO THE FULLEST EXTENT PERMITTED BY LAW, TO INDEMNIFY AND HOLD HARMLESS LRI FROM ANY DAMAGES, LIABILITIES OR COSTS, INCLUDING REASONABLE ATTORNEY'S FEES AND COST OF DEFENSE, ARISING FROM SUCH CHANGES.**

**IN ADDITION, THE CLIENT AGREES TO INCLUDE IN ANY CONTRACTS FOR CONSTRUCTION APPROPRIATE LANGUAGE THAT PROHIBITS THE CONTRACTOR OR ANY SUBCONTRACTORS OF ANY TIER FROM MAKING ANY CHANGES OR MODIFICATIONS TO LRI'S CONSTRUCTION DOCUMENTS WITHOUT THE PRIOR WRITTEN APPROVAL OF LRI AND THAT FURTHER REQUIRES THE CONTRACTOR TO INDEMNIFY BOTH LRI AND THE CLIENT FROM ANY LIABILITY OR COST ARISING FROM SUCH CHANGES MADE WITHOUT SUCH PROPER AUTHORIZATION.**

**GENERAL NOTES:**  
 EXISTING SERVICES AND UTILITIES SHOWN ON THESE DRAWINGS ARE TAKEN FROM THE BEST AVAILABLE RECORDS, BUT MAY NOT BE COMPLETE OR TO DATE. CONTRACTOR SHALL VERIFY IN FIELD FOR LOCATION AND ELEVATION OF PIPES AND CHECK WITH THE UTILITY COMPANIES BEFORE DIGGING OR PERFORMING WORK.

**CONTRACTOR IS ADVISED TO COLLECT INFORMATION ON SOIL CONDITIONS BEFORE START OF CONSTRUCTION.**

**THE ENGINEER WAIVES ANY AND ALL RESPONSIBILITY AND LIABILITY FOR PROBLEMS WHICH ARISE FROM FAILURE TO FOLLOW THESE PLANS, SPECIFICATIONS AND OTHER CONSTRUCTION DOCUMENTS WITHOUT THE PRIOR WRITTEN APPROVAL OF LRI AND THAT FURTHER REQUIRES THE CONTRACTOR TO INDEMNIFY BOTH LRI AND THE CLIENT FROM ANY LIABILITY OR COST ARISING FROM SUCH CHANGES MADE WITHOUT SUCH PROPER AUTHORIZATION.**

**CONTRACTOR TO VERIFY ALL DIMENSIONS AND NOTIFY THE ENGINEER OF ANY DISCREPANCIES BEFORE WORK COMMENCES. DO NOT SCALE DRAWINGS.**

5m 2 0 5m  
 SCALE: 1:200

**NOT FOR CONSTRUCTION TENDER OR PERMIT**

(TO BE DELETED BY STRUCTURAL ENGINEER)  
 1200x900 CULVERT WITH 150mm THICKNESS @ 0.10% SLOPE  
 IN INV = 90.266  
 OUT INV = 90.266

200-300mm RIP-RAP STOP WITH 0.60m THICK TOP OF TERRACE OR EQUIVALENT

01	ISSUED FOR APPROVAL	M.L.	22 APR 2022
No.	REVISIONS	BY	DATE

**PROFESSIONAL ENGINEER**  
 M. BASNET  
 100501996  
 2022/04/22  
 PROVINCE OF ONTARIO

NOT AUTHENTIC UNLESS SIGNED AND DATED

**LRI**  
 ENGINEERING | INGÉNIERIE  
 5430 Canotek Road | Ottawa, ON, K1J 9G2  
 www.lri.ca | (613) 842-3434

CLIENT: **HALO CAR WASH INC.**

DESIGNED BY: M.L./P.P. DRAWN BY: M.L. APPROVED BY: M.B.

PROJECT: **HALO CAR WASH**  
 3535 BORRISOKANE RD  
 BARRHAVEN, ON

DRAWING TITLE: **SERVICING PLAN**

PROJECT NO: 210691  
 DATE: JANUARY 2022

**C401**

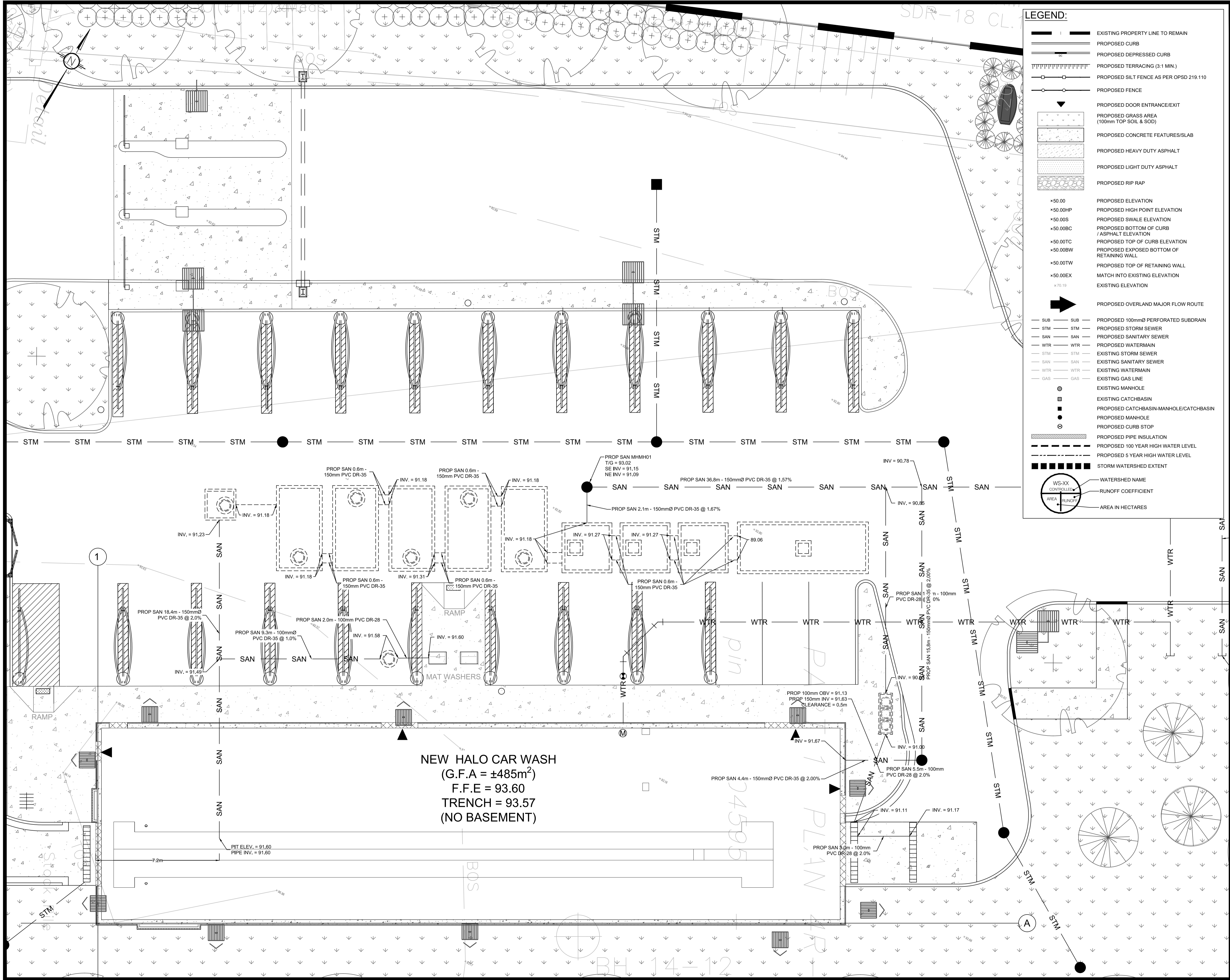

**LEGEND:**

- EXISTING PROPERTY LINE TO REMAIN
- PROPOSED CURB
- PROPOSED DEPRESSED CURB
- PROPOSED TERRACING (3:1 MIN)
- PROPOSED SILT FENCE AS PER OPSD 219.110
- PROPOSED FENCE
- PROPOSED DOOR ENTRANCE/EXIT
- PROPOSED GRASS AREA (100mm TOP SOIL & SOD)
- PROPOSED CONCRETE FEATURES/SLAB
- PROPOSED HEAVY DUTY ASPHALT
- PROPOSED LIGHT DUTY ASPHALT
- PROPOSED RIP RAP
- PROPOSED ELEVATION
- PROPOSED HIGH POINT ELEVATION
- PROPOSED SWALE ELEVATION
- PROPOSED BOTTOM OF CURB / ASPHALT ELEVATION
- PROPOSED TOP OF CURB ELEVATION
- PROPOSED EXPOSED BOTTOM OF RETAINING WALL
- PROPOSED TOP OF RETAINING WALL
- MATCH INTO EXISTING ELEVATION
- EXISTING ELEVATION
- PROPOSED OVERLAND MAJOR FLOW ROUTE
- PROPOSED 100mmØ PERFORATED SUBDRAIN
- PROPOSED STORM SEWER
- PROPOSED SANITARY SEWER
- PROPOSED WATERMAIN
- EXISTING STORM SEWER
- EXISTING SANITARY SEWER
- EXISTING WATERMAIN
- EXISTING GAS LINE
- EXISTING MANHOLE
- EXISTING CATCHBASIN
- PROPOSED CATCHBASIN-MANHOLE/CATCHBASIN
- PROPOSED MANHOLE
- PROPOSED CURB STOP
- PROPOSED PIPE INSULATION
- PROPOSED 100 YEAR HIGH WATER LEVEL
- PROPOSED 5 YEAR HIGH WATER LEVEL
- STORM WATERSHED EXTENT
- WATERSHED NAME
- RUNOFF COEFFICIENT
- AREA IN HECTARES

**USE AND INTERPRETATION OF DRAWINGS**

GENERAL CONDITIONS OF THE CONTRACT FOR CONSTRUCTION ARE PART OF THE CONTRACT DOCUMENTS AND INTENT OF THE DRAWING. THE CONTRACTOR SHALL BE RESPONSIBLE FOR OBTAINING ALL NECESSARY PERMITS AND APPROVALS FROM THE LOCAL AUTHORITIES AND FOR VERIFYING THE ACCURACY OF ALL INFORMATION PROVIDED BY THE CLIENT. THE CONTRACTOR SHALL BE RESPONSIBLE FOR OBTAINING ALL NECESSARY PERMITS AND APPROVALS FROM THE LOCAL AUTHORITIES AND FOR VERIFYING THE ACCURACY OF ALL INFORMATION PROVIDED BY THE CLIENT.

BY USE OF THE DRAWINGS FOR CONSTRUCTION OF THE PROJECT, THE OWNER CONFIRMS THAT HE HAS REVIEWED AND APPROVED THE DRAWINGS. THE CONTRACTOR SHALL BE RESPONSIBLE FOR OBTAINING ALL NECESSARY PERMITS AND APPROVALS FROM THE LOCAL AUTHORITIES AND FOR VERIFYING THE ACCURACY OF ALL INFORMATION PROVIDED BY THE CLIENT.

AS INSTRUMENTS OF SERVICE, ALL DRAWINGS, SPECIFICATIONS, CAD FILES OR OTHER ELECTRONIC MEDIA AND COPIES THEREOF FURNISHED BY THE ENGINEER ARE HIS PROPERTY. THEY ARE TO BE USED ONLY FOR THE PROJECT AND ARE NOT TO BE USED ON ANY OTHER PROJECT, INCLUDING REPEATS OF THE PROJECT. CHANGES TO THE DRAWINGS MAY ONLY BE MADE BY THE ENGINEER.

UNLESS THE REVISION TITLE IS ISSUED FOR CONSTRUCTION, THESE DRAWINGS SHALL BE CONSIDERED PRELIMINARY AND SHALL NOT BE USED AS A CONSTRUCTION DOCUMENT.

THESE DRAWINGS ILLUSTRATE THE WORK TO BE DONE. THE ENGINEER IS NOT RESPONSIBLE FOR THE MEANS, METHODS, TECHNIQUES, SEQUENCES, AND PROCEDURES USED TO DO THE WORK, OR THE SAFETY ASPECTS OF CONSTRUCTION, AND NOTHING ON THESE DRAWINGS EXPRESSED OR IMPLIED CHANGES THIS CONDITION. CONTRACTOR SHALL DETERMINE ALL CONDITIONS AT THE SITE AND SHALL BE RESPONSIBLE FOR KNOWING HOW THEY AFFECT THE WORK. SUBMITTAL OF A BID TO PERFORM THIS WORK IS A KNOWLEDGE OF THE RESPONSIBILITIES, AND THAT THEY HAVE BEEN FULLY CONSIDERED IN PLANNING OF THE WORK AND THE BID PRICE. NO CLAIMS FOR EXTRA CHARGES DUE TO THESE CONDITIONS WILL BE FORTHCOMING.

**UNAUTHORIZED CHANGES:**

IN THE EVENT THE CLIENT, THE CLIENT'S CONTRACTORS OR SUBCONTRACTORS, OR ANYONE FOR WHOM THE CLIENT IS LEGALLY LIABLE MAKES OR PERMITS TO BE MADE ANY CHANGES TO ANY REPORTS, PLANS, SPECIFICATIONS OR OTHER CONSTRUCTION DOCUMENTS PREPARED BY LRI ASSOCIATES LTD. (LRI) WITHOUT OBTAINING LRI'S PRIOR WRITTEN CONSENT, THE CLIENT SHALL ASSUME FULL RESPONSIBILITY FOR THE RESULTS OF SUCH CHANGES. THEREFORE THE CLIENT AGREES TO WAIVE ANY CLAIM AGAINST LRI AND TO RELEASE LRI FROM ANY LIABILITY ARISING DIRECTLY OR INDIRECTLY FROM SUCH UNAUTHORIZED CHANGES.

IN ADDITION, THE CLIENT AGREES TO THE FULLEST EXTENT PERMITTED BY LAW, TO INDEMNIFY AND HOLD HARMLESS LRI FROM ANY DAMAGES, LIABILITIES OR COSTS, INCLUDING REASONABLE ATTORNEY'S FEES AND COST OF DEFENSE, ARISING FROM SUCH CHANGES.

IN ADDITION, THE CLIENT AGREES TO INCLUDE IN ANY CONTRACTS FOR CONSTRUCTION APPROPRIATE LANGUAGE THAT PROHIBITS THE CONTRACTOR OR ANY SUBCONTRACTORS OF ANY TIER FROM MAKING ANY CHANGES OR MODIFICATIONS TO LRI'S CONSTRUCTION DOCUMENTS WITHOUT THE PRIOR WRITTEN APPROVAL OF LRI AND THAT FURTHER REQUIRES THE CONTRACTOR TO INDEMNIFY BOTH LRI AND THE CLIENT FROM ANY LIABILITY OR COST ARISING FROM SUCH CHANGES MADE WITHOUT SUCH PROPER AUTHORIZATION.

**GENERAL NOTES:**

EXISTING SERVICES AND UTILITIES SHOWN ON THESE DRAWINGS ARE TAKEN FROM THE BEST AVAILABLE RECORDS, BUT MAY NOT BE COMPLETE OR TO DATE. CONTRACTOR SHALL VERIFY IN FIELD FOR LOCATION AND ELEVATION OF PIPES AND CHECK WITH THE UTILITY COMPANIES BEFORE DIGGING OR PERFORMING WORK.

CONTRACTOR IS ADVISED TO COLLECT INFORMATION ON SOIL CONDITIONS BEFORE START OF CONSTRUCTION.

THE ENGINEER WAIVES ANY AND ALL RESPONSIBILITY AND LIABILITY FOR PROBLEMS WHICH ARISE FROM FAILURE TO FOLLOW THESE PLANS, SPECIFICATIONS AND THE ENGINEER'S REPORTS, DRAWINGS, OR FOR PROBLEMS WHICH ARISE FROM OTHERS' FAILURE TO OBTAIN AND/OR FOLLOW THE ENGINEER'S GUIDANCE WITH RESPECT TO ANY ERRORS, OMISSIONS, INCONSISTENCIES, AMBIGUITIES OR CONFLICTS WHICH ARE ALLEGED.

CONTRACTOR TO VERIFY ALL DIMENSIONS AND NOTIFY THE ENGINEER OF ANY DISCREPANCIES BEFORE WORK COMMENCES. DO NOT SCALE DRAWINGS.

No.	REVISIONS	BY	DATE
01	ISSUED FOR APPROVAL	M.L.	22 APR 2022

**NOT FOR CONSTRUCTION TENDER OR PERMIT**

**LRI**  
 ENGINEERING | INGENIERIE  
 5430 Canotek Road | Ottawa, ON, K1J 9G2  
 www.lri.ca | (613) 842-3434

CLIENT: HALO CAR WASH INC.

DESIGNED BY: M.L. / P.P.    DRAWN BY: M.L.    APPROVED BY: M.B.

PROJECT: HALO CAR WASH  
 3535 BORRISOKANE RD  
 BARRHAVEN, ON

DRAWING TITLE: CAR WASH WASTEWATER TREATMENT & RECLAMATION SYSTEM

PROJECT NO: 210691  
 DATE: JANUARY 2022

**LRI**  
 ENGINEERING | INGENIERIE  
 5430 Canotek Road | Ottawa, ON, K1J 9G2  
 www.lri.ca | (613) 842-3434

CLIENT: HALO CAR WASH INC.

DESIGNED BY: M.L. / P.P.    DRAWN BY: M.L.    APPROVED BY: M.B.

PROJECT: HALO CAR WASH  
 3535 BORRISOKANE RD  
 BARRHAVEN, ON

DRAWING TITLE: CAR WASH WASTEWATER TREATMENT & RECLAMATION SYSTEM

PROJECT NO: 210691  
 DATE: JANUARY 2022

**C402**

# FLAGSTAFF PHASE

## PHASE 3 (HMB WEST)

FLAGSTAFF DRIVE

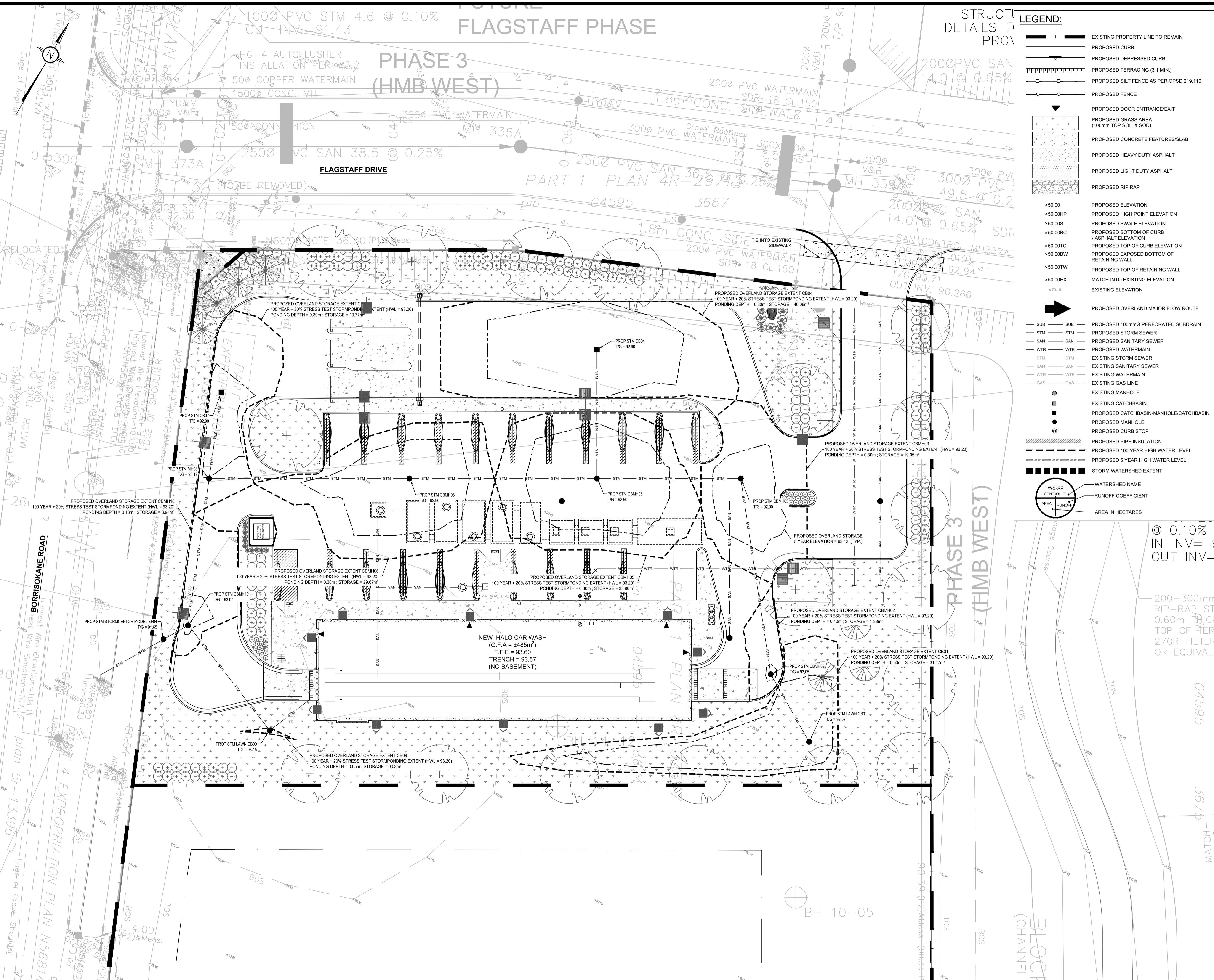

**LEGEND:**

- EXISTING PROPERTY LINE TO REMAIN
- PROPOSED CURB
- PROPOSED DEPRESSED CURB
- PROPOSED TERRACING (3:1 MIN.)
- PROPOSED SILT FENCE AS PER OPSD 219.110
- PROPOSED FENCE
- PROPOSED DOOR ENTRANCE/EXIT
- PROPOSED GRASS AREA (100mm TOP SOIL & SOD)
- PROPOSED CONCRETE FEATURES/SLAB
- PROPOSED HEAVY DUTY ASPHALT
- PROPOSED LIGHT DUTY ASPHALT
- PROPOSED RIP RAP
- \*50.00 PROPOSED ELEVATION
- \*50.00HP PROPOSED HIGH POINT ELEVATION
- \*50.00S PROPOSED SWALE ELEVATION
- \*50.00BC PROPOSED BOTTOM OF CURB / ASPHALT ELEVATION
- \*50.00TC PROPOSED TOP OF CURB ELEVATION
- \*50.00BW PROPOSED EXPOSED BOTTOM OF RETAINING WALL
- \*50.00TW PROPOSED TOP OF RETAINING WALL
- \*50.00EX EXISTING ELEVATION
- PROPOSED OVERLAND MAJOR FLOW ROUTE
- SUB PROPOSED 100mm PERFORATED SUBDRAIN
- STM PROPOSED STORM SEWER
- SAN PROPOSED SANITARY SEWER
- WTR PROPOSED WATERMAIN
- STM EXISTING STORM SEWER
- SAN EXISTING SANITARY SEWER
- WTR EXISTING WATERMAIN
- GAS EXISTING GAS LINE
- EXISTING MANHOLE
- EXISTING CATCHBASIN
- PROPOSED CATCHBASIN-MANHOLE/CATCHBASIN
- PROPOSED MANHOLE
- PROPOSED CURB STOP
- PROPOSED PIPE INSULATION
- PROPOSED 100 YEAR HIGH WATER LEVEL
- PROPOSED 5 YEAR HIGH WATER LEVEL
- STORM WATERSHED EXTENT
- WS-XX WATERSHED NAME
- AREA RUNOFF COEFFICIENT
- AREA IN HECTARES

**GENERAL CONDITIONS OF DRAWINGS**

GENERAL CONDITIONS OF THE CONTRACT FOR CONSTRUCTION ARE PART OF THE CONTRACT DOCUMENTS AND DESCRIBE THE SCOPE AND INTENT OF THE DRAWING. THE CONTRACTOR SHALL BE RESPONSIBLE FOR OBTAINING ALL NECESSARY PERMITS AND APPROVALS FROM THE LOCAL AUTHORITY. THE CONTRACTOR SHALL BE RESPONSIBLE FOR VERIFYING THE ACCURACY OF ALL INFORMATION PROVIDED BY THE CLIENT AND FOR OBTAINING ALL NECESSARY PERMITS AND APPROVALS FROM THE LOCAL AUTHORITY. THE CONTRACTOR SHALL BE RESPONSIBLE FOR OBTAINING ALL NECESSARY PERMITS AND APPROVALS FROM THE LOCAL AUTHORITY. THE CONTRACTOR SHALL BE RESPONSIBLE FOR OBTAINING ALL NECESSARY PERMITS AND APPROVALS FROM THE LOCAL AUTHORITY.

**UNAUTHORIZED CHANGES:**

IN THE EVENT THE CLIENT, THE CLIENT'S CONTRACTORS OR SUBCONTRACTORS, OR ANYONE FOR WHOM THE CLIENT IS LEGALLY LIABLE MAKES OR PERMITS TO BE MADE ANY CHANGES TO ANY REPORT, SPECIFICATION, OR OTHER CONSTRUCTION DOCUMENTS PREPARED BY LRI ASSOCIATES LTD. (LRI) WITHOUT OBTAINING LRI'S PRIOR WRITTEN CONSENT, THE CLIENT SHALL ASSUME FULL RESPONSIBILITY FOR THE RESULTS OF SUCH CHANGES. THEREFORE THE CLIENT AGREES TO WAIVE ANY CLAIM AGAINST LRI AND TO RELEASE LRI FROM ANY LIABILITY ARISING DIRECTLY OR INDIRECTLY FROM SUCH UNAUTHORIZED CHANGES.

**IN ADDITION, THE CLIENT AGREES TO THE FULLEST EXTENT PERMITTED BY LAW, TO INDEMNIFY AND HOLD HARMLESS LRI FROM ANY DAMAGES, LIABILITIES OR COSTS, INCLUDING REASONABLE ATTORNEY'S FEES AND COST OF DEFENSE, ARISING FROM SUCH CHANGES.**

**IN ADDITION, THE CLIENT AGREES TO INCLUDE IN ANY CONTRACTS FOR CONSTRUCTION APPROPRIATE LANGUAGE THAT PROHIBITS THE CONTRACTOR OR ANY SUBCONTRACTORS OF ANY TIER FROM MAKING ANY CHANGES OR MODIFICATIONS TO LRI'S CONSTRUCTION DOCUMENTS WITHOUT THE PRIOR WRITTEN APPROVAL OF LRI AND THAT FURTHER REQUIRES THE CONTRACTOR TO INDEMNIFY BOTH LRI AND THE CLIENT FROM ANY LIABILITY OR COST ARISING FROM SUCH CHANGES MADE WITHOUT SUCH PROPER AUTHORIZATION.**

**GENERAL NOTES:**

EXISTING SERVICES AND UTILITIES SHOWN ON THESE DRAWINGS ARE TAKEN FROM THE BEST AVAILABLE RECORDS, BUT MAY NOT BE COMPLETE OR TO DATE. CONTRACTOR SHALL VERIFY IN FIELD FOR LOCATION AND ELEVATION OF PIPES AND CHECK WITH THE UTILITY COMPANIES BEFORE DIGGING OR PERFORMING WORK.

CONTRACTOR IS ADVISED TO COLLECT INFORMATION ON SOIL CONDITIONS BEFORE START OF CONSTRUCTION.

THE ENGINEER WAIVES ANY AND ALL RESPONSIBILITY AND LIABILITY FOR PROBLEMS WHICH ARISE FROM FAILURE TO FOLLOW THESE PLANS, SPECIFICATIONS AND THE NEAREST PRELIMINARY, SPECIFICATIONS OR OTHER CONSTRUCTION DOCUMENTS WITHOUT THE PRIOR WRITTEN APPROVAL OF LRI AND THAT FURTHER REQUIRES THE CONTRACTOR TO INDEMNIFY BOTH LRI AND THE CLIENT FROM ANY LIABILITY OR COST ARISING FROM SUCH CHANGES MADE WITHOUT SUCH PROPER AUTHORIZATION.

CONTRACTOR TO VERIFY ALL DIMENSIONS AND NOTIFY THE ENGINEER OF ANY DISCREPANCIES BEFORE WORK COMMENCES. DO NOT SCALE DRAWINGS.

5m 2 0 5m  
SCALE: 1:200

**NOT FOR CONSTRUCTION TENDER OR PERMIT**

ISSUED FOR APPROVAL M.L. 22 APR 2022

No.	REVISIONS	BY	DATE

CONTROLLED BY

**M. BASNET**  
100501996  
2022/04/22  
PROVINCE OF ONTARIO

NOT AUTHENTIC UNLESS SIGNED AND DATED

**LRJ**  
ENGINEERING | INGENIERIE  
5430 Canotek Road | Ottawa, ON, K1J 9G2  
www.lri.ca | (613) 842-3434

CLIENT: **HALO CAR WASH INC.**

DESIGNED BY: M.L./P.P. DRAWN BY: M.L. APPROVED BY: M.B.

PROJECT: **HALO CAR WASH  
3535 BORRISOKANE RD  
BARRHAVEN, ON**

DRAWING TITLE: **STORMWATER MANAGEMENT PLAN**

PROJECT NO: 210691 DATE: JANUARY 2022

**C601**

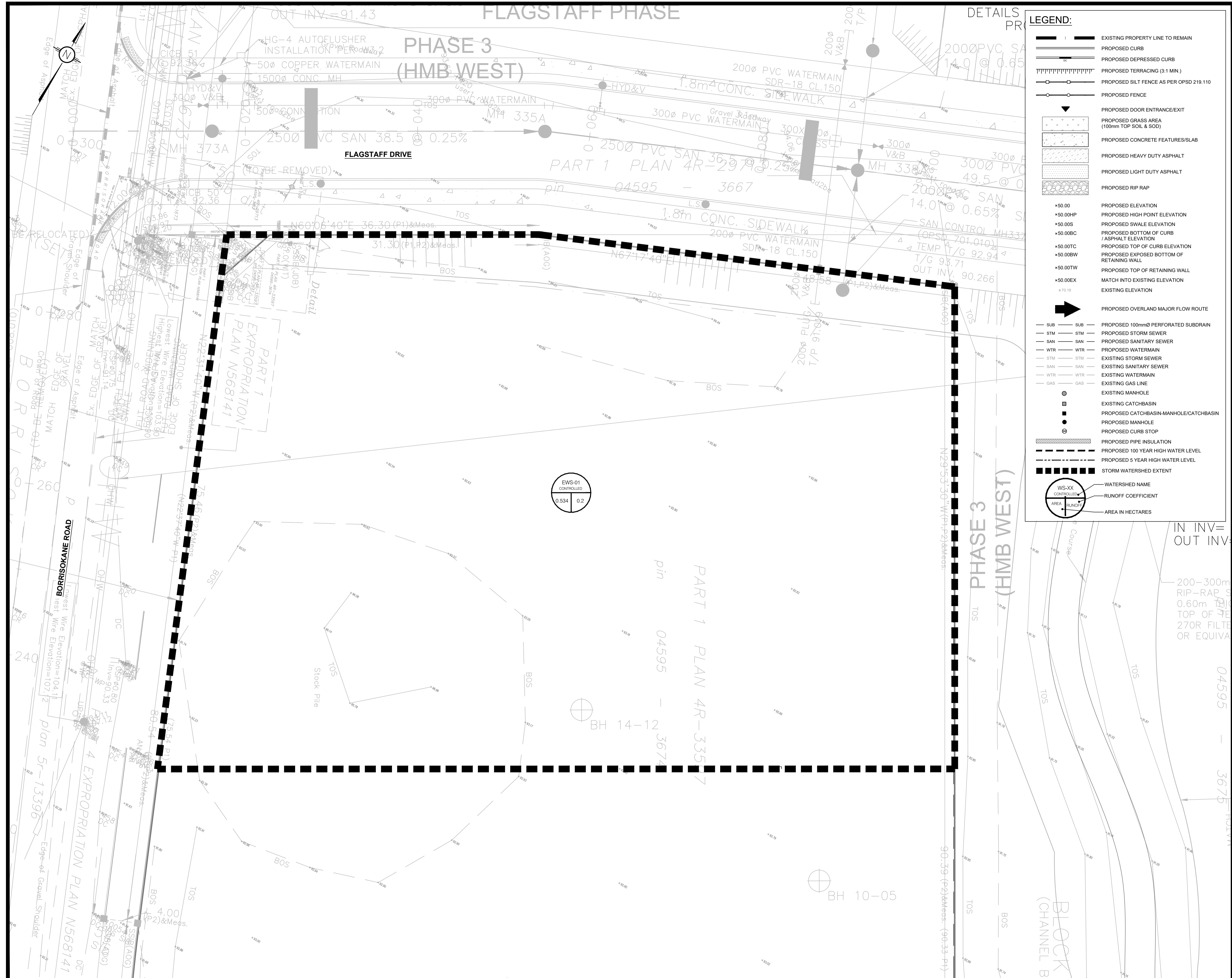

**LEGEND:**

- EXISTING PROPERTY LINE TO REMAIN
- PROPOSED CURB
- PROPOSED DEPRESSED CURB
- PROPOSED TERRACING (3:1 MIN.)
- PROPOSED SILT FENCE AS PER OPSD 219.110
- PROPOSED FENCE
- PROPOSED DOOR ENTRANCE/EXIST
- PROPOSED GRASS AREA (100mm TOP SOIL & SOD)
- PROPOSED CONCRETE FEATURES/SLAB
- PROPOSED HEAVY DUTY ASPHALT
- PROPOSED LIGHT DUTY ASPHALT
- PROPOSED RIP RAP
- PROPOSED ELEVATION
- PROPOSED HIGH POINT ELEVATION
- PROPOSED SWALE ELEVATION
- PROPOSED BOTTOM OF CURB / ASPHALT ELEVATION
- PROPOSED TOP OF CURB ELEVATION
- PROPOSED EXPOSED BOTTOM OF RETAINING WALL
- PROPOSED TOP OF RETAINING WALL
- MATCH INTO EXISTING ELEVATION
- EXISTING ELEVATION
- PROPOSED OVERLAND MAJOR FLOW ROUTE
- PROPOSED 100mm PERFORATED SUBDRAIN
- PROPOSED STORM SEWER
- PROPOSED SANITARY SEWER
- PROPOSED WATERMAIN
- EXISTING STORM SEWER
- EXISTING SANITARY SEWER
- EXISTING WATERMAIN
- EXISTING GAS LINE
- EXISTING MANHOLE
- EXISTING CATCHBASIN
- PROPOSED CATCHBASIN/MANHOLE/CATCHBASIN
- PROPOSED MANHOLE
- PROPOSED CURB STOP
- PROPOSED PIPE INSULATION
- PROPOSED 100 YEAR HIGH WATER LEVEL
- PROPOSED 5 YEAR HIGH WATER LEVEL
- STORM WATERSHED EXTENT
- WATERSHED NAME
- RUNOFF COEFFICIENT
- AREA IN HECTARES

**USE AND INTERPRETATION OF DRAWINGS**

GENERAL CONDITIONS OF THE CONTRACT FOR CONSTRUCTION ARE PART OF THE CONTRACT DOCUMENTS AND DESCRIBE THE SCOPE AND INTENT OF THE DRAWING. THE CONTRACTOR SHALL BE RESPONSIBLE FOR VERIFYING THE ACCURACY OF THE DATA AND INFORMATION PROVIDED IN THE CONTRACT DOCUMENTS. THE CONTRACTOR SHALL BE RESPONSIBLE FOR OBTAINING ALL NECESSARY PERMITS AND APPROVALS FROM THE LOCAL AUTHORITIES. THE CONTRACTOR SHALL BE RESPONSIBLE FOR OBTAINING ALL NECESSARY PERMITS AND APPROVALS FROM THE LOCAL AUTHORITIES. THE CONTRACTOR SHALL BE RESPONSIBLE FOR OBTAINING ALL NECESSARY PERMITS AND APPROVALS FROM THE LOCAL AUTHORITIES.

BY USE OF THE DRAWINGS FOR CONSTRUCTION OF THE PROJECT, THE OWNER CONFIRMS THAT HE HAS REVIEWED AND APPROVED THE DRAWINGS. THE CONTRACTOR CONFIRMS THAT HE HAS VISITED THE SITE, FAMILIARIZED HIMSELF WITH THE LOCAL CONDITIONS, VERIFIED FIELD DIMENSIONS AND CORRELATED HIS OBSERVATIONS WITH THE CONTRACT DOCUMENTS.

AS INSTRUMENTS OF SERVICE, ALL DRAWINGS, SPECIFICATIONS, CAD FILES OR OTHER ELECTRONIC MEDIA AND COPIES THEREOF FURNISHED BY THE ENGINEER ARE HIS PROPERTY. THEY ARE TO BE USED ONLY FOR THIS PROJECT AND ARE NOT TO BE USED ON ANY OTHER PROJECT, INCLUDING REPEATS OF THE PROJECT. CHANGES TO THE DRAWINGS MAY ONLY BE MADE BY THE ENGINEER.

UNLESS THE REVISION TITLE IS "ISSUED FOR CONSTRUCTION", THESE DRAWINGS SHALL BE CONSIDERED PRELIMINARY AND SHALL NOT BE USED AS A CONSTRUCTION DOCUMENT.

THESE DRAWINGS ILLUSTRATE THE WORK TO BE DONE. THE ENGINEER IS NOT RESPONSIBLE FOR THE MEANS, METHODS, TECHNIQUES, SEQUENCES, AND PROCEDURES USED TO DO THE WORK, OR THE SAFETY ASPECTS OF CONSTRUCTION, AND NOTHING ON THESE DRAWINGS EXPRESSED OR IMPLIED CHANGES THIS CONDITION. CONTRACTOR SHALL DETERMINE ALL CONDITIONS AT THE SITE AND SHALL BE RESPONSIBLE FOR KNOWING HOW THEY AFFECT THE WORK. SUBMITTAL OF A BID TO PERFORM THIS WORK IS ACKNOWLEDGEMENT OF THE RESPONSIBILITIES, AND THAT THEY HAVE BEEN FULLY CONSIDERED IN PLANNING OF THE WORK, AND THE BID PRICE. NO CLAIMS FOR EXTRA CHARGES DUE TO THESE CONDITIONS WILL BE FORTHCOMING.

UNAUTHORIZED CHANGES:

IN THE EVENT THE CLIENT, THE CLIENT'S CONTRACTORS OR SUBCONTRACTORS, OR ANYONE FOR WHOM THE CLIENT IS LEGALLY LIABLE MAKES OR PERMITS TO BE MADE ANY CHANGES TO ANY REPORTS, PLANS, SPECIFICATIONS OR OTHER CONSTRUCTION DOCUMENTS PREPARED BY IRL ASSOCIATES LTD. (IRL) WITHOUT OBTAINING IRL'S PRIOR WRITTEN CONSENT, THE CLIENT SHALL ASSUME FULL RESPONSIBILITY FOR THE RESULTS OF SUCH CHANGES. THEREFORE THE CLIENT AGREES TO WAIVE ANY CLAIM AGAINST IRL AND TO RELEASE IRL FROM ANY LIABILITY ARISING DIRECTLY OR INDIRECTLY FROM SUCH UNAUTHORIZED CHANGES.

IN ADDITION, THE CLIENT AGREES TO THE FULLEST EXTENT PERMITTED BY LAW, TO INDEMNIFY AND HOLD HARMLESS IRL FROM ANY DAMAGES, LIABILITIES OR COSTS, INCLUDING REASONABLE ATTORNEY'S FEES AND COSTS OF DEFENSE, ARISING FROM SUCH CHANGES.

IN ADDITION, THE CLIENT AGREES TO INCLUDE IN ANY CONTRACTS FOR CONSTRUCTION APPROPRIATE LANGUAGE THAT PROHIBITS THE CONTRACTOR OR ANY SUBCONTRACTORS OF ANY TIER FROM MAKING ANY CHANGES OR MODIFICATIONS TO IRL'S CONSTRUCTION DOCUMENTS WITHOUT THE PRIOR WRITTEN APPROVAL OF IRL AND THAT FURTHER REQUIRES THE CONTRACTOR TO INDEMNIFY BOTH IRL AND THE CLIENT FROM ANY LIABILITY OR COST ARISING FROM SUCH CHANGES MADE WITHOUT SUCH PROPER AUTHORIZATION.

**GENERAL NOTES:**

EXISTING SERVICES AND UTILITIES SHOWN ON THESE DRAWINGS ARE TAKEN FROM THE BEST AVAILABLE RECORDS, BUT MAY NOT BE COMPLETE OR TO DATE. CONTRACTOR SHALL VERIFY IN FIELD FOR LOCATION AND ELEVATION OF PIPES AND CHECK WITH THE UTILITY COMPANIES BEFORE DIGGING OR PERFORMING WORK.

CONTRACTOR IS ADVISED TO COLLECT INFORMATION ON SOIL CONDITIONS BEFORE START OF CONSTRUCTION.

THE ENGINEER WAIVES ANY AND ALL RESPONSIBILITY AND LIABILITY FOR PROBLEMS WHICH ARISE FROM FAILURE TO FOLLOW THESE PLANS, SPECIFICATIONS AND THE GENERAL NOTES HEREON, OR FOR PROBLEMS WHICH ARISE FROM OTHERS' FAILURE TO OBTAIN AND/OR FOLLOW THE ENGINEER'S GUIDANCE WITH RESPECT TO ANY ERRORS, OMISSIONS, INCONSISTENCIES, AMBIGUITIES OR CONFLICTS WHICH ARE ALLEGED.

CONTRACTOR TO VERIFY ALL DIMENSIONS AND NOTIFY THE ENGINEER OF ANY DISCREPANCIES BEFORE WORK COMMENCES. DO NOT SCALE DRAWINGS.

5m  
SCALE: 1:200

**NOT FOR CONSTRUCTION TENDER OR PERMIT**

No.	ISSUED FOR APPROVAL	M.L.	22 APR 2022
No.	REVISIONS	BY	DATE

PROFESSIONAL ENGINEER  
M. BASNET  
100501996  
2022/04/22  
PROVINCE OF ONTARIO

NOT AUTHENTIC UNLESS SIGNED AND DATED

**LRJ**  
ENGINEERING | INGENIERIE  
5430 Canotek Road | Ottawa, ON, K1J 9G2  
www.lrl.ca | (613) 842-3434

CLIENT: HALO CAR WASH INC.

DESIGNED BY: M.L. / P.P.    DRAWN BY: M.L.    APPROVED BY: M.B.

PROJECT: HALO CAR WASH  
3535 BORRISOKANE RD  
BARRHAVEN, ON

DRAWING TITLE: PRE-DEVELOPMENT WATERSHED PLAN

PROJECT NO: 210691    DATE: JANUARY 2022

**C701**

# FLAGSTAFF PHASE

## PHASE 3 (HMB WEST)

FLAGSTAFF DRIVE

NEW HALO CAR WASH  
(G.F.A = 485m<sup>2</sup>)  
F.F.E = 93.60  
TRENCH = 93.57  
(NO BASEMENT)

### LEGEND:

- EXISTING PROPERTY LINE TO REMAIN
- PROPOSED CURB
- PROPOSED DEPRESSED CURB
- PROPOSED TERRACING (3:1 MIN.)
- PROPOSED SILT FENCE AS PER OPSD 219.110
- PROPOSED FENCE
- PROPOSED DOOR ENTRANCE/EXIT
- PROPOSED GRASS AREA (100mm TOP SOIL & SOD)
- PROPOSED CONCRETE FEATURES/SLAB
- PROPOSED HEAVY DUTY ASPHALT
- PROPOSED LIGHT DUTY ASPHALT
- PROPOSED RIP RAP
- PROPOSED ELEVATION
- PROPOSED HIGH POINT ELEVATION
- PROPOSED SWALE ELEVATION
- PROPOSED BOTTOM OF CURB / ASPHALT ELEVATION
- PROPOSED TOP OF CURB ELEVATION
- PROPOSED EXPOSED BOTTOM OF RETAINING WALL
- PROPOSED TOP OF RETAINING WALL
- MATCH INTO EXISTING ELEVATION
- EXISTING ELEVATION
- PROPOSED OVERLAND MAJOR FLOW ROUTE
- PROPOSED 100mmØ PERFORATED SUBDRAIN
- PROPOSED STORM SEWER
- PROPOSED SANITARY SEWER
- PROPOSED WATERMAIN
- EXISTING STORM SEWER
- EXISTING SANITARY SEWER
- EXISTING WATERMAIN
- EXISTING GAS LINE
- EXISTING MANHOLE
- EXISTING CATCHBASIN
- PROPOSED CATCHBASIN-MANHOLE/CATCHBASIN
- PROPOSED MANHOLE
- PROPOSED CURB STOP
- PROPOSED PIPE INSULATION
- PROPOSED 100 YEAR HIGH WATER LEVEL
- PROPOSED 5 YEAR HIGH WATER LEVEL
- STORM WATERSHED EXTENT
- WATERSHED NAME
- RUNOFF COEFFICIENT
- AREA IN HECTARES

**GENERAL CONDITIONS OF DRAWINGS**

GENERAL CONDITIONS OF THE CONTRACT FOR CONSTRUCTION ARE PART OF THE CONTRACT DOCUMENTS AND DESCRIBE THE SCOPE AND INTENT OF THE DRAWINGS. THE CONTRACTOR SHALL BE RESPONSIBLE FOR OBTAINING ALL NECESSARY PERMITS AND APPROVALS FROM THE LOCAL AUTHORITIES. THE CONTRACTOR SHALL BE RESPONSIBLE FOR OBTAINING ALL NECESSARY PERMITS AND APPROVALS FROM THE LOCAL AUTHORITIES. THE CONTRACTOR SHALL BE RESPONSIBLE FOR OBTAINING ALL NECESSARY PERMITS AND APPROVALS FROM THE LOCAL AUTHORITIES.

**UNAUTHORIZED CHANGES:**

IN THE EVENT THE CLIENT, THE CLIENT'S CONTRACTORS OR SUBCONTRACTORS, OR ANYONE FOR WHOM THE CLIENT IS LEGALLY LIABLE MAKES OR PERMITS TO BE MADE ANY CHANGES TO ANY REPORTS, PLANS, SPECIFICATIONS OR OTHER CONSTRUCTION DOCUMENTS PREPARED BY LRI ASSOCIATES LTD. (LRI) WITHOUT OBTAINING LRI'S PRIOR WRITTEN CONSENT, THE CLIENT SHALL ASSUME FULL RESPONSIBILITY FOR THE RESULTS OF SUCH CHANGES. THEREFORE THE CLIENT AGREES TO WAIVE ANY CLAIM AGAINST LRI AND TO RELEASE LRI FROM ANY LIABILITY ARISING DIRECTLY OR INDIRECTLY FROM SUCH UNAUTHORIZED CHANGES.

**IN ADDITION, THE CLIENT AGREES TO THE FULLEST EXTENT PERMITTED BY LAW, TO INDEMNIFY AND HOLD HARMLESS LRI FROM ANY DAMAGES, LIABILITIES OR COSTS, INCLUDING REASONABLE ATTORNEY'S FEES AND COSTS OF DEFENSE, ARISING FROM SUCH CHANGES.**

**IN ADDITION, THE CLIENT AGREES TO INCLUDE IN ANY CONTRACTS FOR CONSTRUCTION APPROPRIATE LANGUAGE THAT PROHIBITS THE CONTRACTOR OR ANY SUBCONTRACTORS OF ANY TIER FROM MAKING ANY CHANGES OR MODIFICATIONS TO LRI'S CONSTRUCTION DOCUMENTS WITHOUT THE PRIOR WRITTEN APPROVAL OF LRI AND THAT FURTHER REQUIRES THE CONTRACTOR TO INDEMNIFY BOTH LRI AND THE CLIENT FROM ANY LIABILITY OR COST ARISING FROM SUCH CHANGES MADE WITHOUT SUCH PROPER AUTHORIZATION.**

**GENERAL NOTES:**

EXISTING SERVICES AND UTILITIES SHOWN ON THESE DRAWINGS ARE TAKEN FROM THE BEST AVAILABLE RECORDS, BUT MAY NOT BE COMPLETE OR TO DATE. CONTRACTOR SHALL VERIFY IN FIELD FOR LOCATION AND ELEVATION OF PIPES AND CHECK WITH THE UTILITY COMPANIES BEFORE DIGGING OR PERFORMING WORK.

CONTRACTOR IS ADVISED TO COLLECT INFORMATION ON SOIL CONDITIONS BEFORE START OF CONSTRUCTION.

THE ENGINEER WAIVES ANY AND ALL RESPONSIBILITY AND LIABILITY FOR PROBLEMS WHICH ARISE FROM FAILURE TO FOLLOW THESE PLANS, SPECIFICATIONS AND THE BIDDING REQUIREMENTS WITHOUT THE PRIOR WRITTEN APPROVAL OF LRI AND THAT FURTHER REQUIRES THE CONTRACTOR TO INDEMNIFY BOTH LRI AND THE CLIENT FROM ANY LIABILITY OR COST ARISING FROM SUCH CHANGES MADE WITHOUT SUCH PROPER AUTHORIZATION.

CONTRACTOR TO VERIFY ALL DIMENSIONS AND NOTIFY THE ENGINEER OF ANY DISCREPANCIES BEFORE WORK COMMENCES. DO NOT SCALE DRAWINGS.

NOT FOR CONSTRUCTION TENDER OR PERMIT

No.	ISSUED FOR APPROVAL	M.L.	22 APR 2022
REVISIONS	BY	DATE	
01	ISSUED FOR APPROVAL	M.L.	22 APR 2022



CLIENT

**HALO CAR WASH INC.**

DESIGNED BY: M.L. / P.P. DRAWN BY: M.L. APPROVED BY: M.B.

PROJECT

**HALO CAR WASH**  
3535 BORRISOKANE RD  
BARRHAVEN, ON

DRAWING TITLE

**POST-DEVELOPMENT WATERSHED PLAN**

PROJECT NO. 210691

DATE JANUARY 2022

**C702**

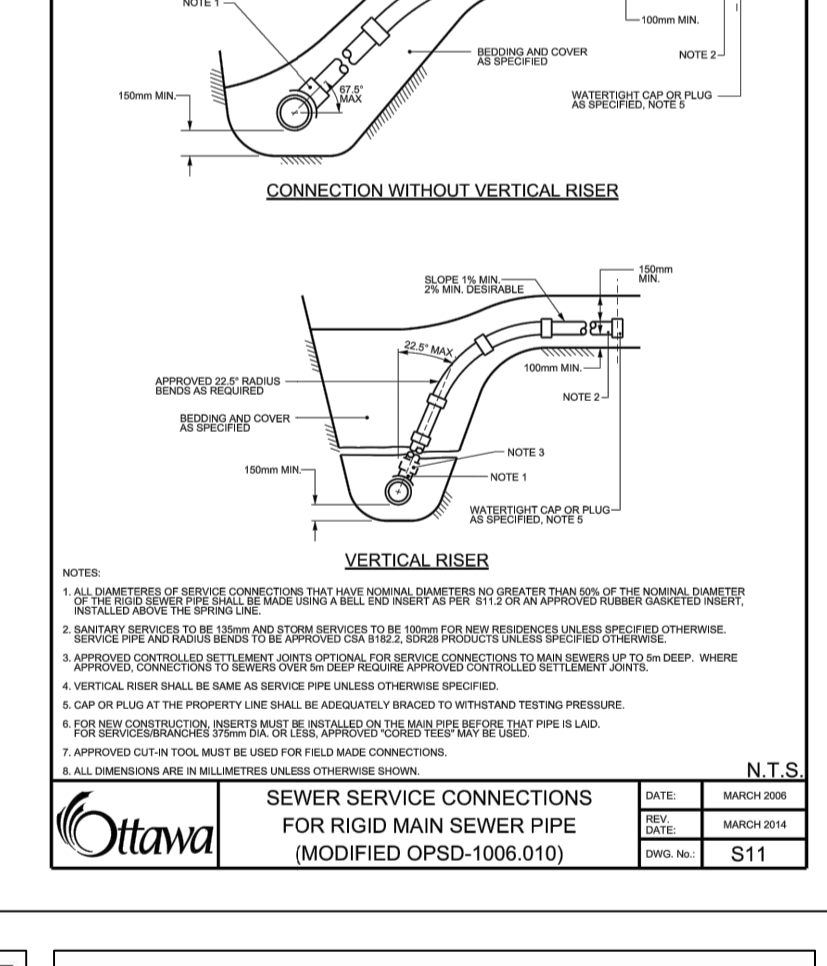
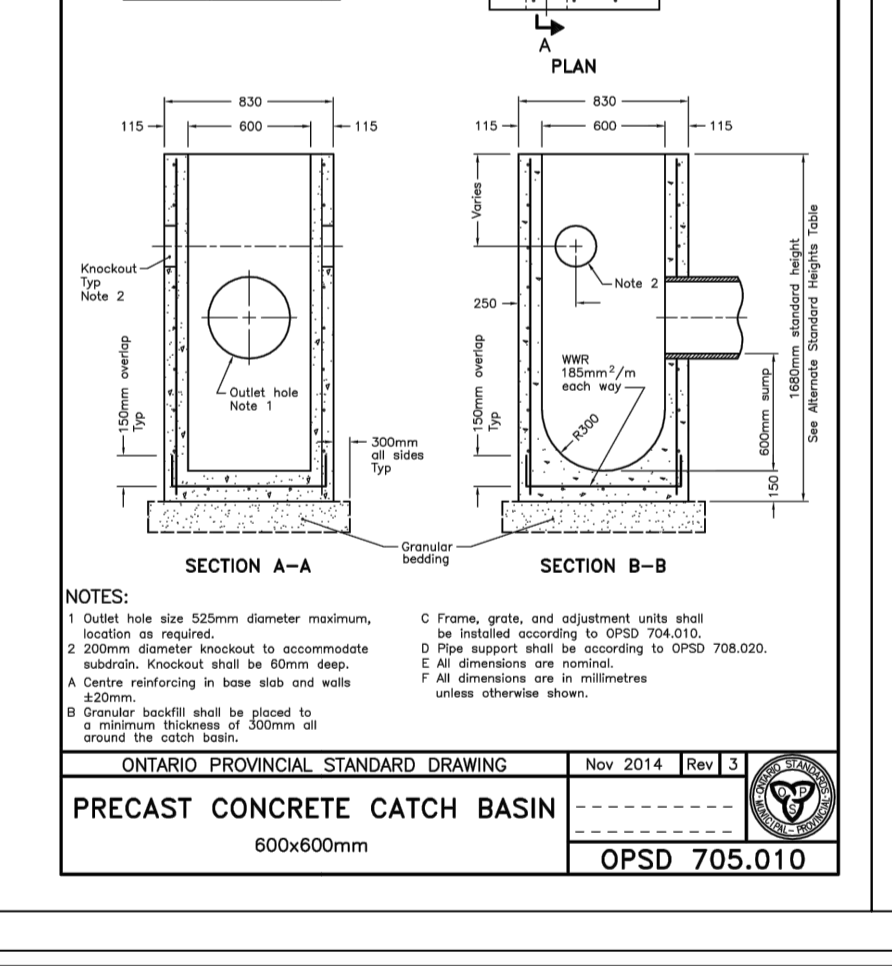
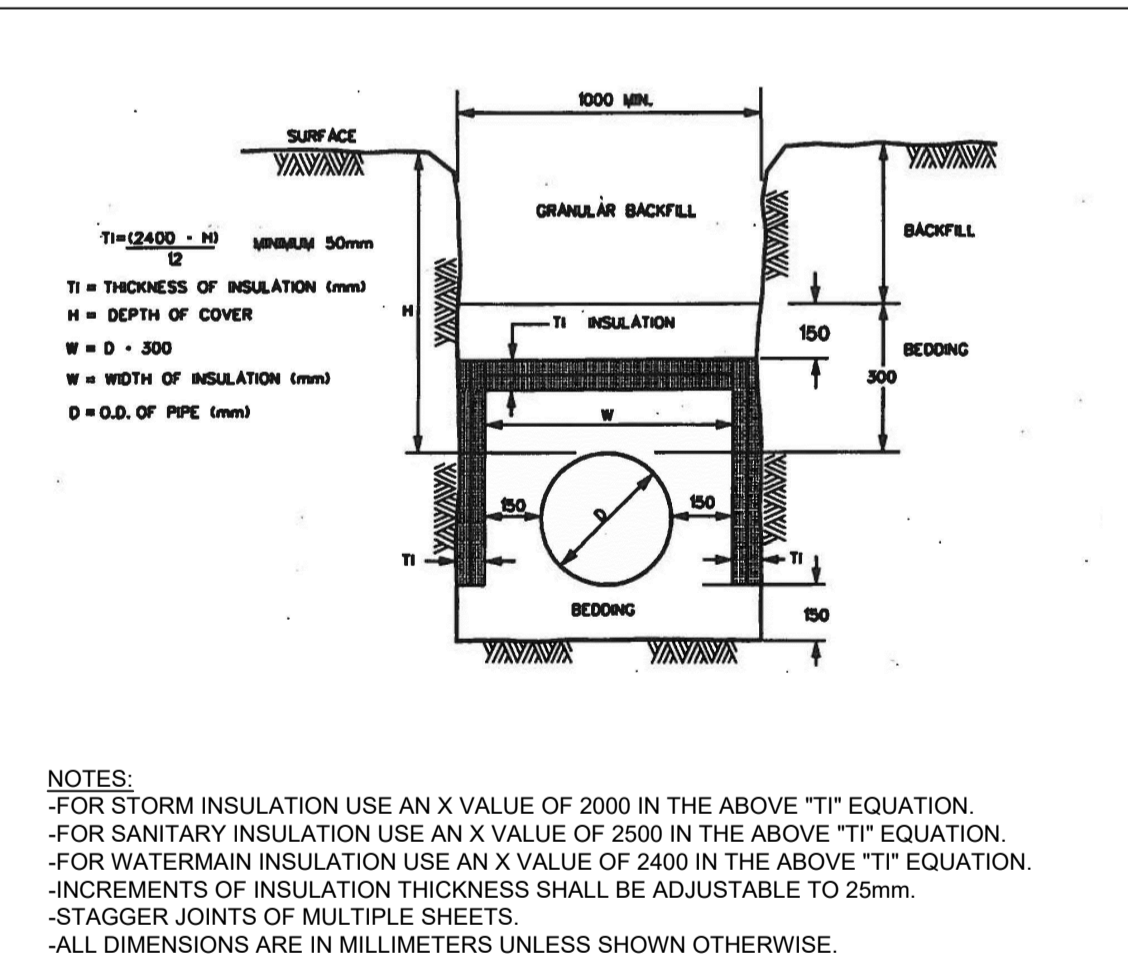
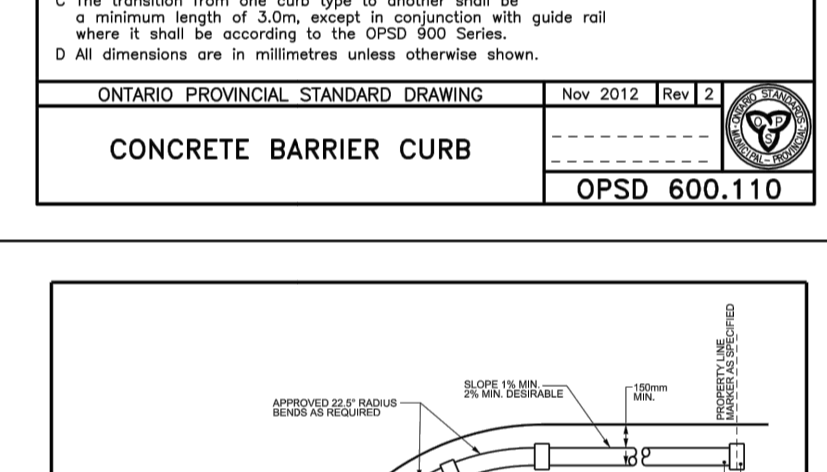
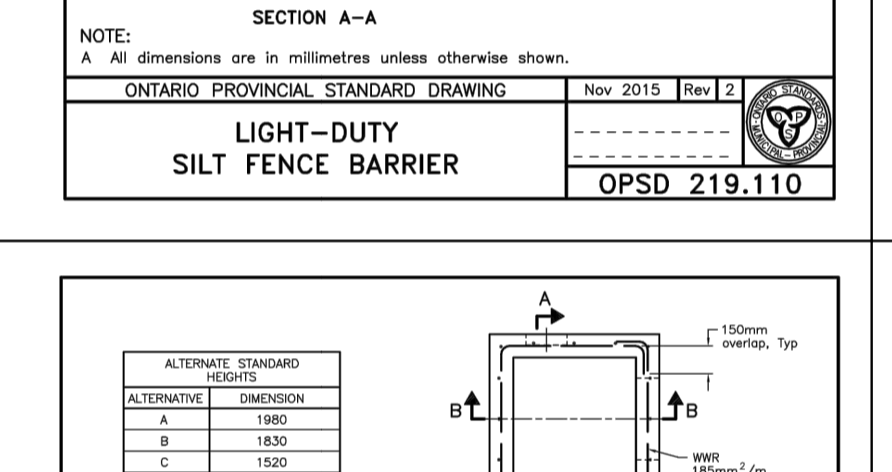
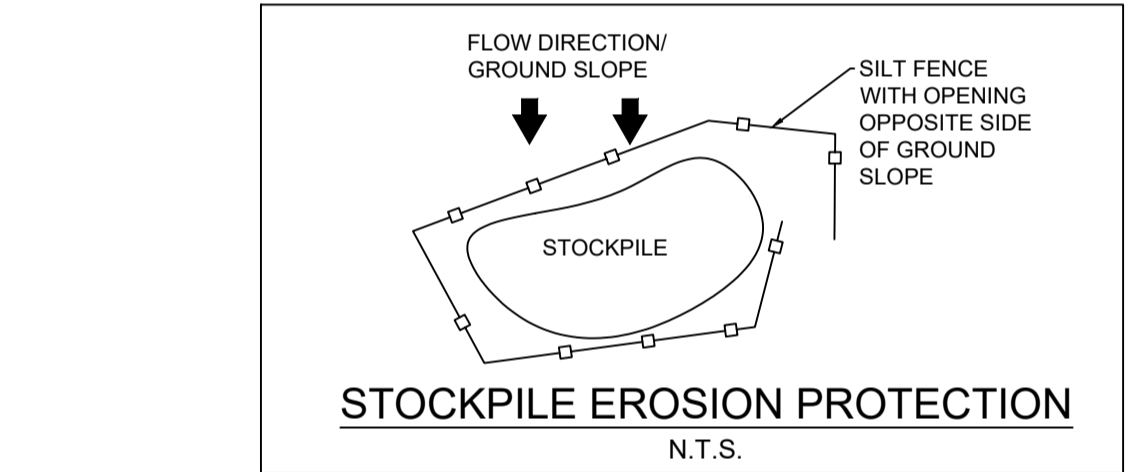
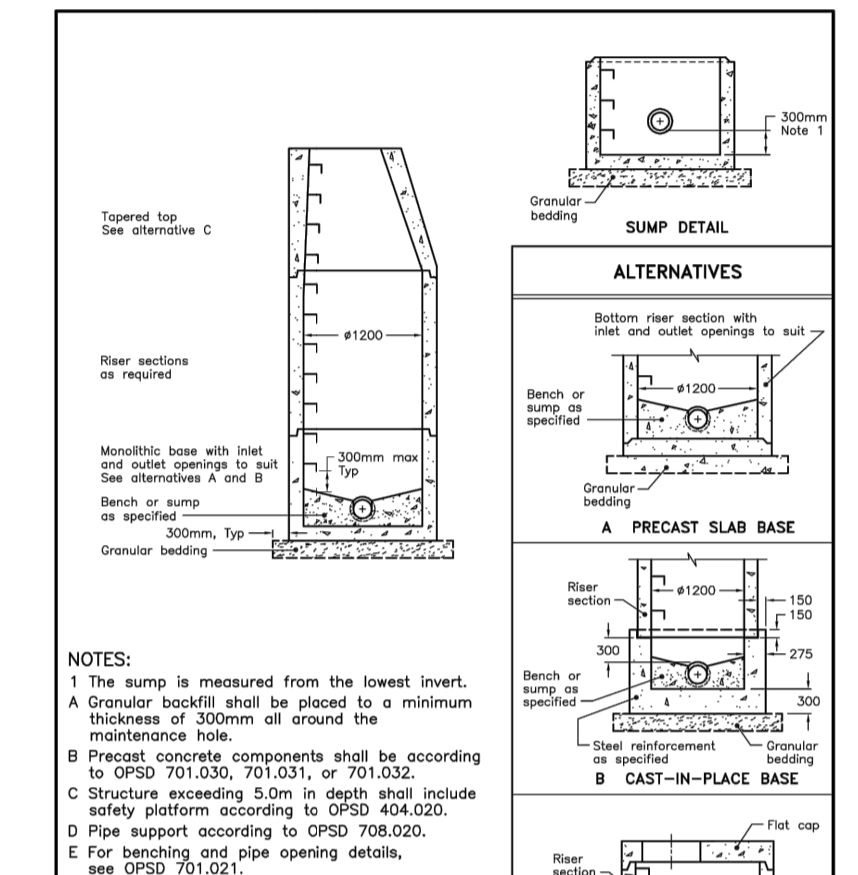
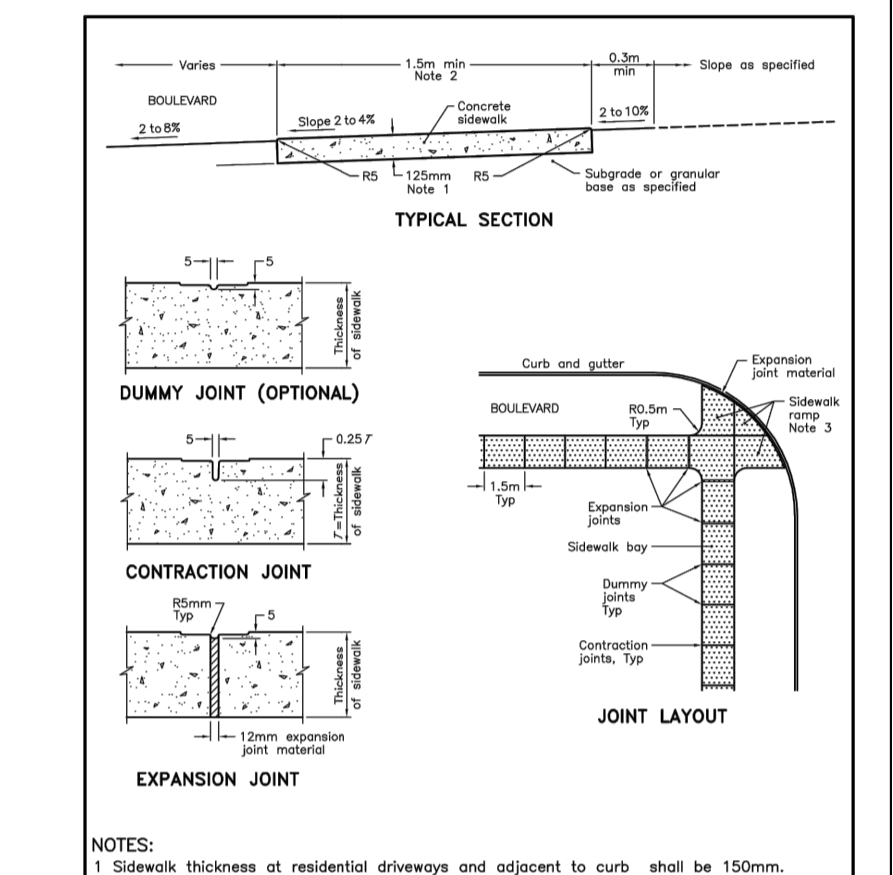
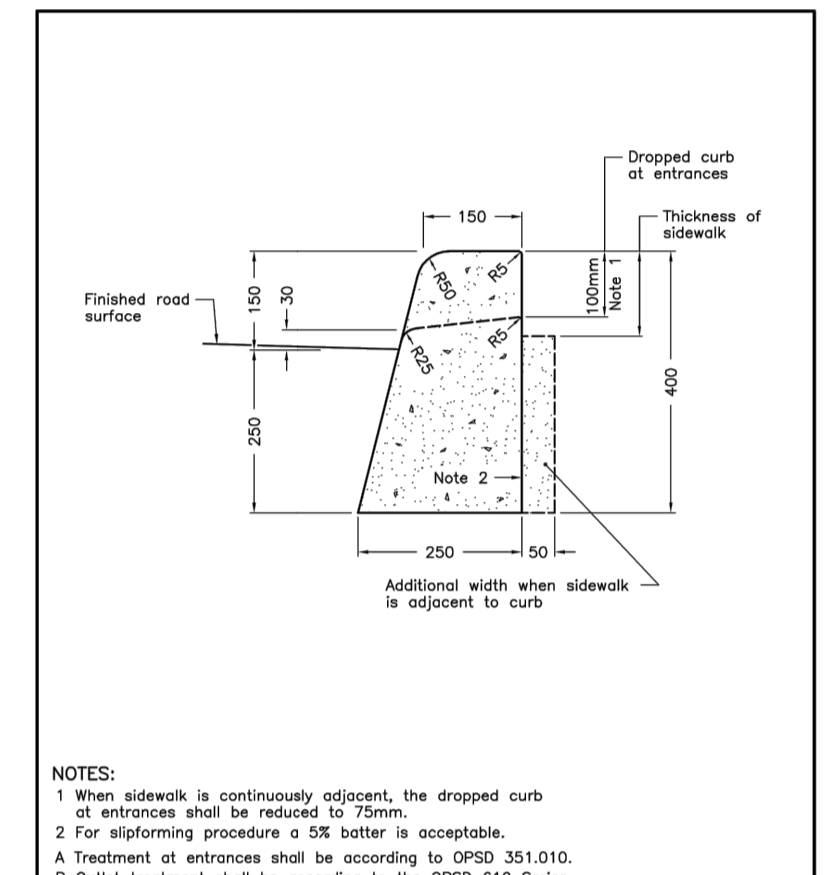
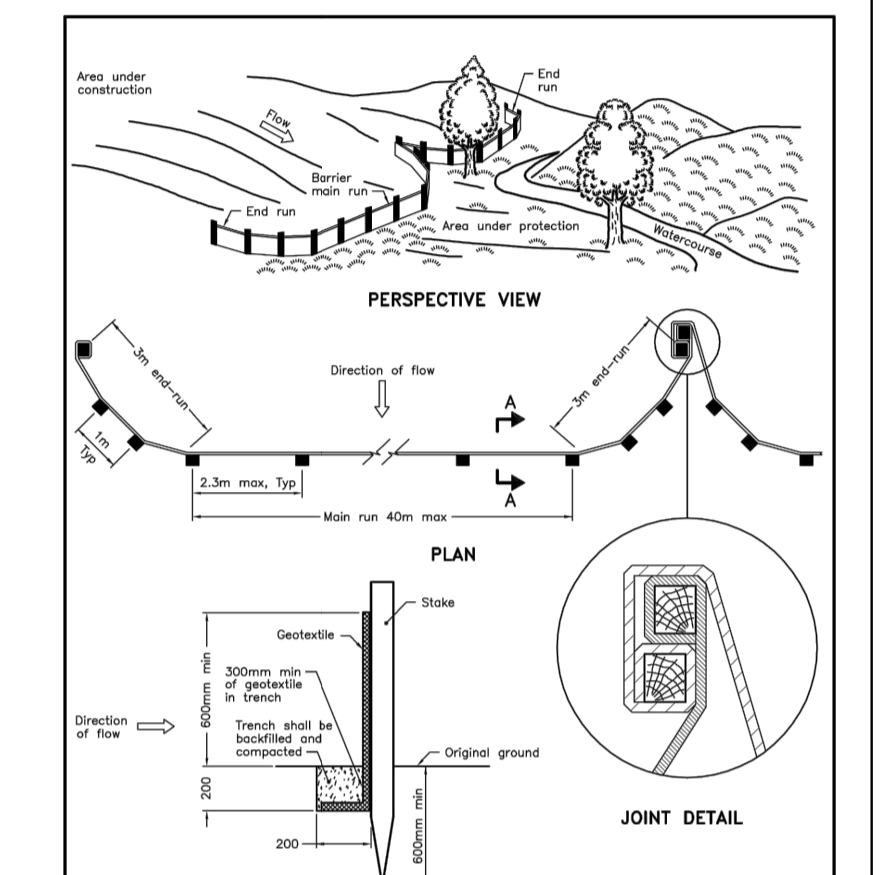
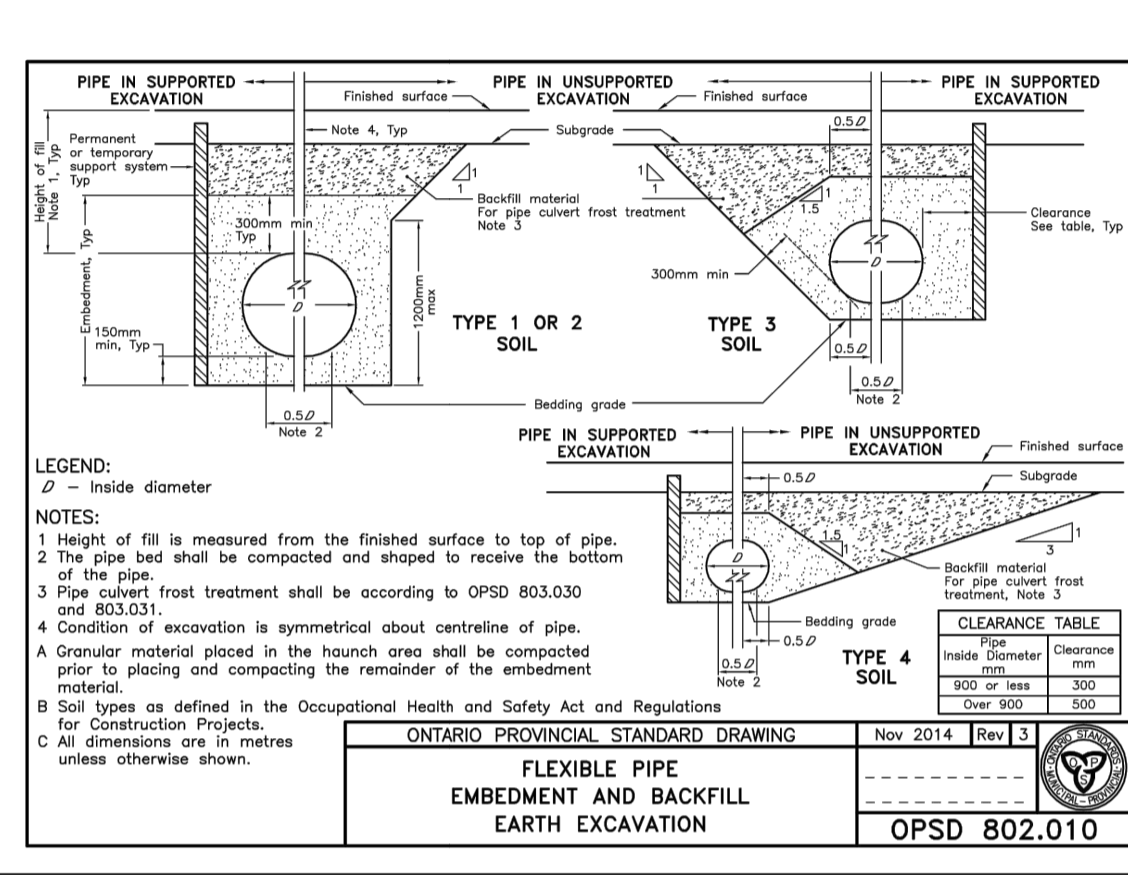
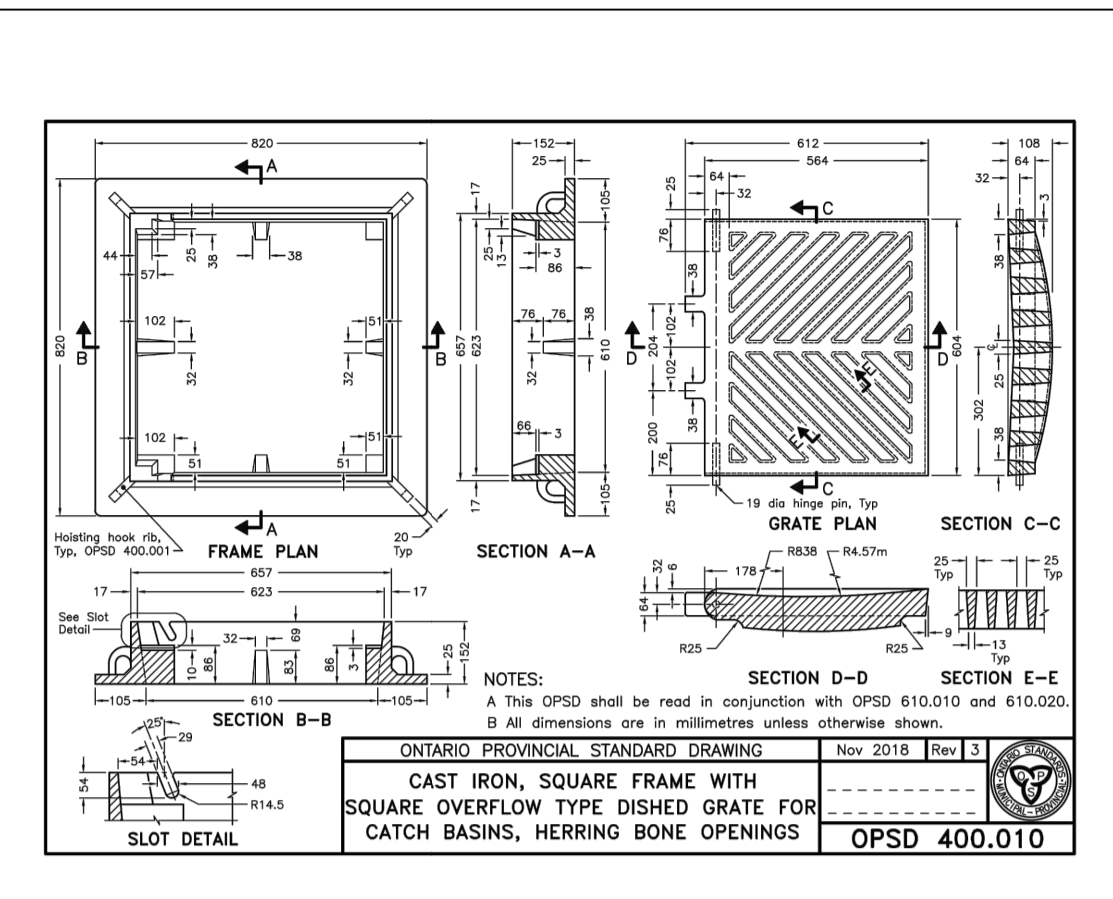
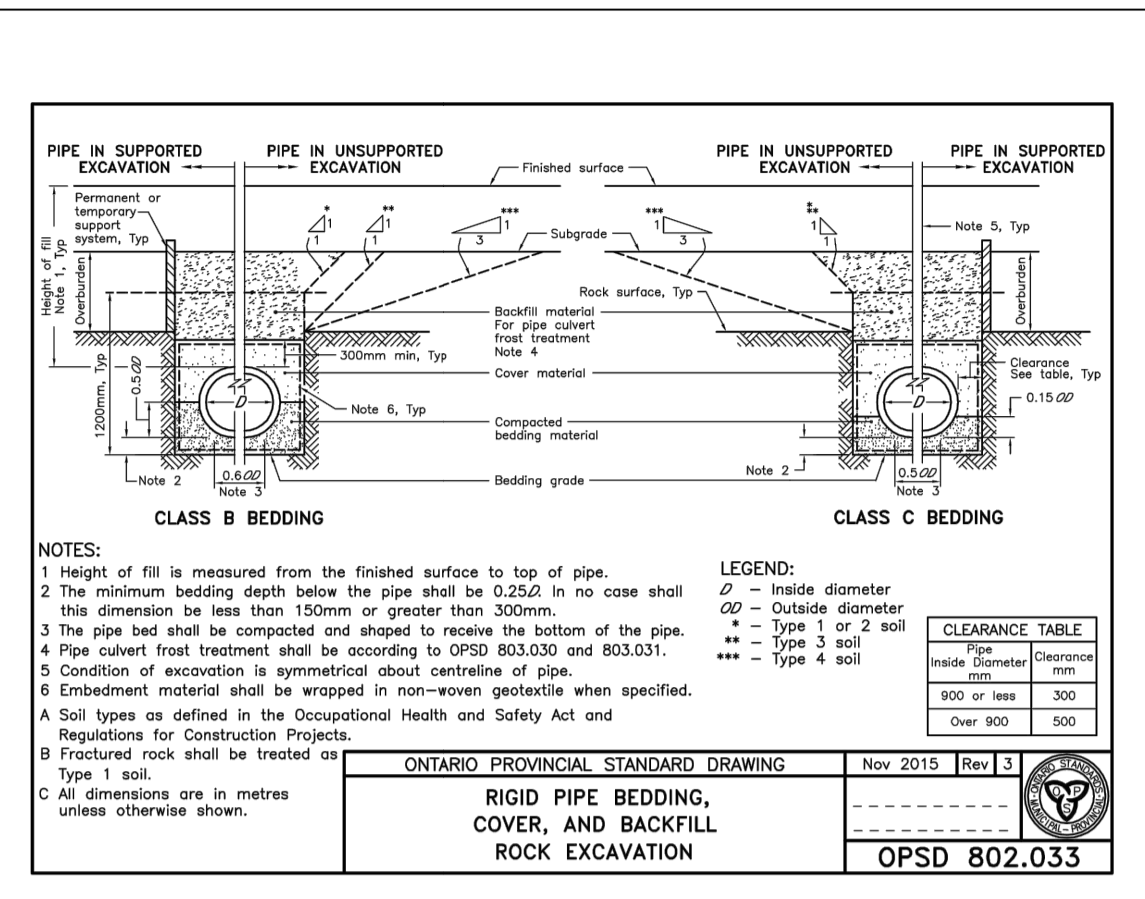
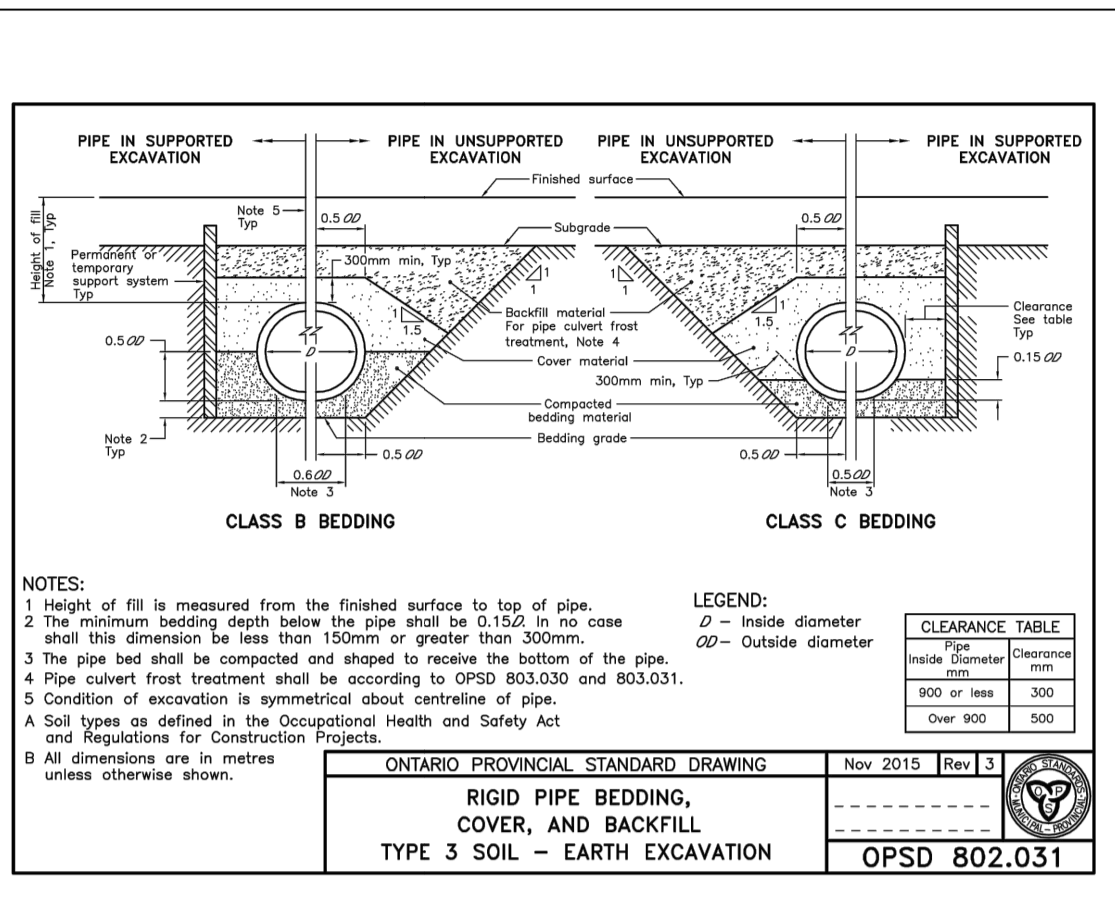
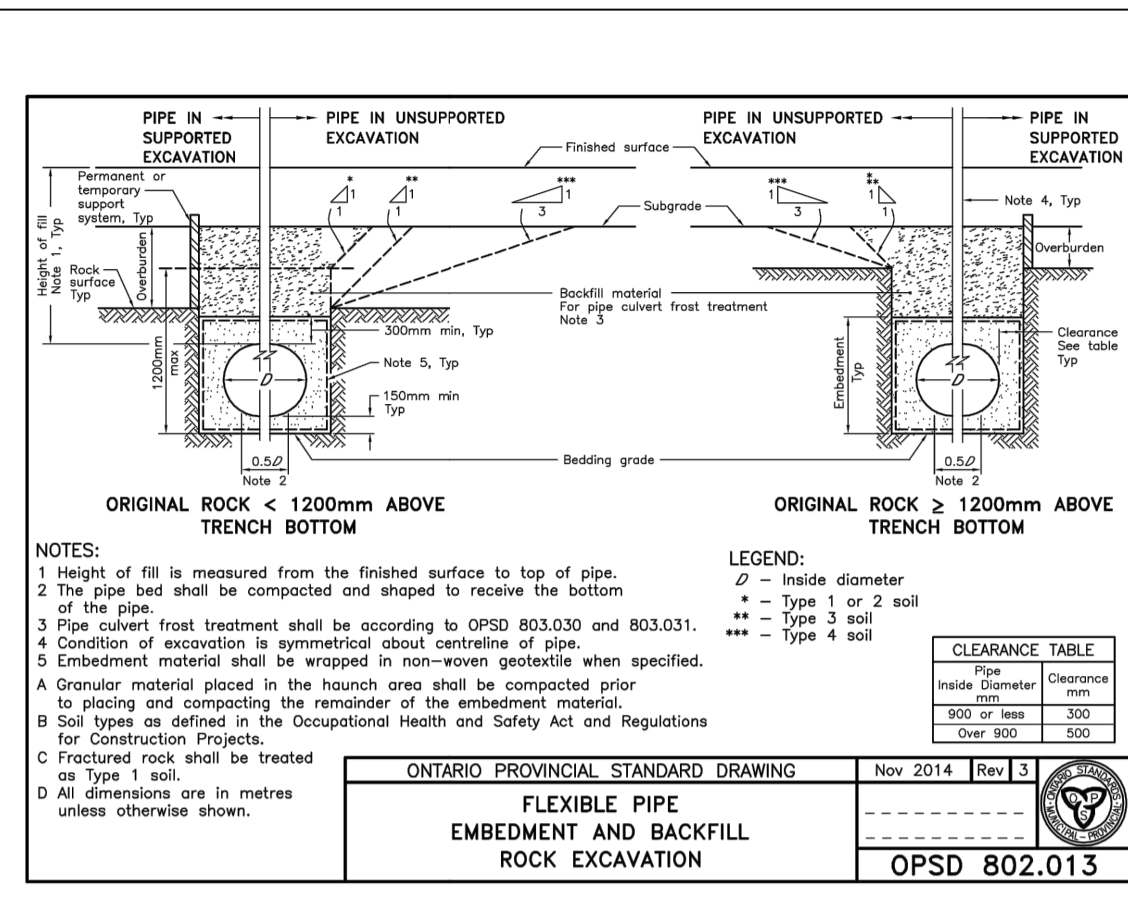

**USE AND INTERPRETATION OF DRAWINGS**

GENERAL CONDITIONS OF THE CONTRACT FOR CONSTRUCTION ARE PART OF THE CONTRACT DOCUMENTS AND DESCRIBE THE SCOPE AND INTENT OF THE DRAWINGS. THE CONTRACT DOCUMENTS INCLUDE NOT ONLY THE DRAWINGS, BUT ALSO THE OWNER-CONTRACTOR AGREEMENTS, CONDITIONS OF THE CONTRACT, THE SPECIFICATIONS, ADDENDA, AND MODIFICATIONS ISSUED AFTER EXECUTION OF THE CONTRACT. THESE CONTRACT DOCUMENTS ARE COMPLEMENTARY, AND WHAT IS REQUIRED BY ANY ONE SHALL BE BINDING AS REQUIRED BY ALL WORK NOT COMPLETELY DELINEATED HEREON SHALL BE CONSTRUCTED OF THE SAME MATERIALS AND INSTALLED EXACTLY AS SHOWN MORE COMPLETELY ELSEWHERE IN THE CONTRACT DOCUMENTS.

BY USE OF THE DRAWINGS FOR CONSTRUCTION OF THE PROJECT, THE OWNER CONFIRMS THAT HE HAS REVIEWED AND APPROVED THE DRAWINGS. THE CONTRACTOR CONFIRMS THAT HE HAS VISITED THE SITE, FAMILIARIZED HIMSELF WITH THE LOCAL CONDITIONS, VERIFIED FIELD DIMENSIONS AND CORRELATED HIS OBSERVATIONS WITH THE REQUIREMENTS OF THE CONTRACT DOCUMENTS.

AS INSTRUMENTS OF SERVICE, ALL DRAWINGS, SPECIFICATIONS, CAD FILES OR OTHER ELECTRONIC MEDIA AND COPIES THEREOF FURNISHED BY THE ENGINEER ARE HIS PROPERTY. THEY ARE TO BE USED ONLY FOR THIS PROJECT AND ARE NOT TO BE USED ON ANY OTHER PROJECT, INCLUDING REPEATS OF THE PROJECT. CHANGES TO THE DRAWINGS MAY ONLY BE MADE BY THE ENGINEER.

UNLESS THE REVISION TITLE IS ISSUED FOR CONSTRUCTION, THESE DRAWINGS SHALL BE CONSIDERED PRELIMINARY AND SHALL NOT BE USED AS A CONSTRUCTION DOCUMENT.

THESE DRAWINGS ILLUSTRATE THE WORK TO BE DONE. THE ENGINEER IS NOT RESPONSIBLE FOR THE MEANS, METHODS, TECHNIQUES, SEQUENCES, AND PROCEDURES USED TO DO THE WORK, OR THE SAFETY ASPECTS OF CONSTRUCTION, AND NOTHING ON THESE DRAWINGS EXPRESSED OR IMPLIED CHANGES THIS CONDITION. CONTRACTOR SHALL DETERMINE ALL CONDITIONS AT THE SITE AND SHALL BE RESPONSIBLE FOR KNOWING HOW THEY AFFECT THE WORK. SUBMITTAL OF A BID TO PERFORM THIS WORK IS ACKNOWLEDGMENT OF THE RESPONSIBILITIES, AND THAT THEY HAVE BEEN FULLY CONSIDERED DUE TO THESE CONDITIONS WILL BE FORTHCOMING.

**UNAUTHORIZED CHANGES:**

IN THE EVENT THE CLIENT, THE CLIENT'S CONTRACTORS OR SUBCONTRACTORS, OR ANYONE FOR WHOM THE CLIENT IS LEGALLY LIABLE MAKES OR PERMITS TO BE MADE ANY CHANGES TO REPORTS, PLANS, SPECIFICATIONS OR OTHER CONSTRUCTION DOCUMENTS PREPARED BY LRI ASSOCIATES LTD. (LRI) WITHOUT OBTAINING LRI'S PRIOR WRITTEN CONSENT, THE CLIENT SHALL ASSUME FULL RESPONSIBILITY FOR THE RESULTS OF SUCH CHANGES. THEREFORE THE CLIENT AGREES TO WAIVE ANY CLAIM AGAINST LRI AND TO RELEASE LRI FROM ANY LIABILITY ARISING DIRECTLY OR INDIRECTLY FROM SUCH UNAUTHORIZED CHANGES.

IN ADDITION, THE CLIENT AGREES TO THE FULLEST EXTENT PERMITTED BY LAW, TO INDEMNIFY AND HOLD HARMLESS LRI FROM ANY DAMAGES, LIABILITIES OR COSTS, INCLUDING REASONABLE ATTORNEY'S FEES AND COST OF DEFENSE, ARISING FROM SUCH CHANGES.

IN ADDITION, THE CLIENT AGREES TO INCLUDE IN ANY CONTRACTS FOR CONSTRUCTION APPROPRIATE LANGUAGE THAT PROHIBITS THE CONTRACTOR OR ANY SUBCONTRACTORS OF ANY TIER FROM MAKING ANY CHANGES OR MODIFICATIONS TO LRI'S CONSTRUCTION DOCUMENTS WITHOUT THE PRIOR WRITTEN APPROVAL OF LRI AND THAT FURTHER REQUIRES THE CONTRACTOR TO INDEMNIFY BOTH LRI AND THE CLIENT FROM ANY LIABILITY OR COST ARISING FROM SUCH CHANGES MADE WITHOUT SUCH PROPER AUTHORIZATION.

**GENERAL NOTES:**

EXISTING SERVICES AND UTILITIES SHOWN ON THESE DRAWINGS ARE TAKEN FROM THE BEST AVAILABLE RECORDS, BUT MAY NOT BE COMPLETE OR TO DATE. CONTRACTOR SHALL VERIFY IN FIELD FOR LOCATION AND ELEVATION OF PIPES AND CHECK WITH THE UTILITY COMPANIES BEFORE DIGGING OR PERFORMING WORK.

CONTRACTOR IS ADVISED TO COLLECT INFORMATION ON SOIL CONDITIONS BEFORE START OF CONSTRUCTION.

THE ENGINEER WAIVES ANY AND ALL RESPONSIBILITY AND LIABILITY FOR PROBLEMS WHICH ARISE FROM FAILURE TO FOLLOW THESE PLANS, SPECIFICATIONS AND OTHER CONSTRUCTION DOCUMENTS WITHOUT THE PRIOR WRITTEN APPROVAL OF THE ENGINEER'S GUIDANCE WITH RESPECT TO ANY ERRORS, OMISSIONS, INCONSISTENCIES AMBIGUITIES OR CONFLICTS WHICH ARE ALLEGED.

CONTRACTOR TO VERIFY ALL DIMENSIONS AND NOTIFY THE ENGINEER OF ANY DISCREPANCIES BEFORE WORK COMMENCES. DO NOT SCALE DRAWINGS.

**NOT FOR CONSTRUCTION TENDER OR PERMIT**

01	ISSUED FOR APPROVAL	M.L.	22 APR 2022
No.	REVISIONS	BY	DATE

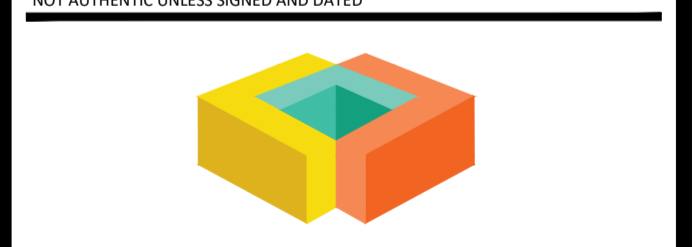

**LRI**  
 ENGINEERING | INGENIERIE  
 5430 Canotek Road | Ottawa, ON, K1J 9G2  
 www.lri.ca | (613) 842-3434

CLIENT: **HALO CAR WASH INC.**

DESIGNED BY: M.L. / P.P. DRAWN BY: M.L. APPROVED BY: M.B.

PROJECT: **HALO CAR WASH 3535 BORRISOKANE RD BARRHAVEN, ON**

DRAWING TITLE: **CONSTRUCTION DETAIL PLAN**

PROJECT NO: 210691 DATE: JANUARY 2022

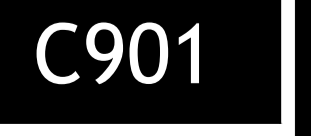

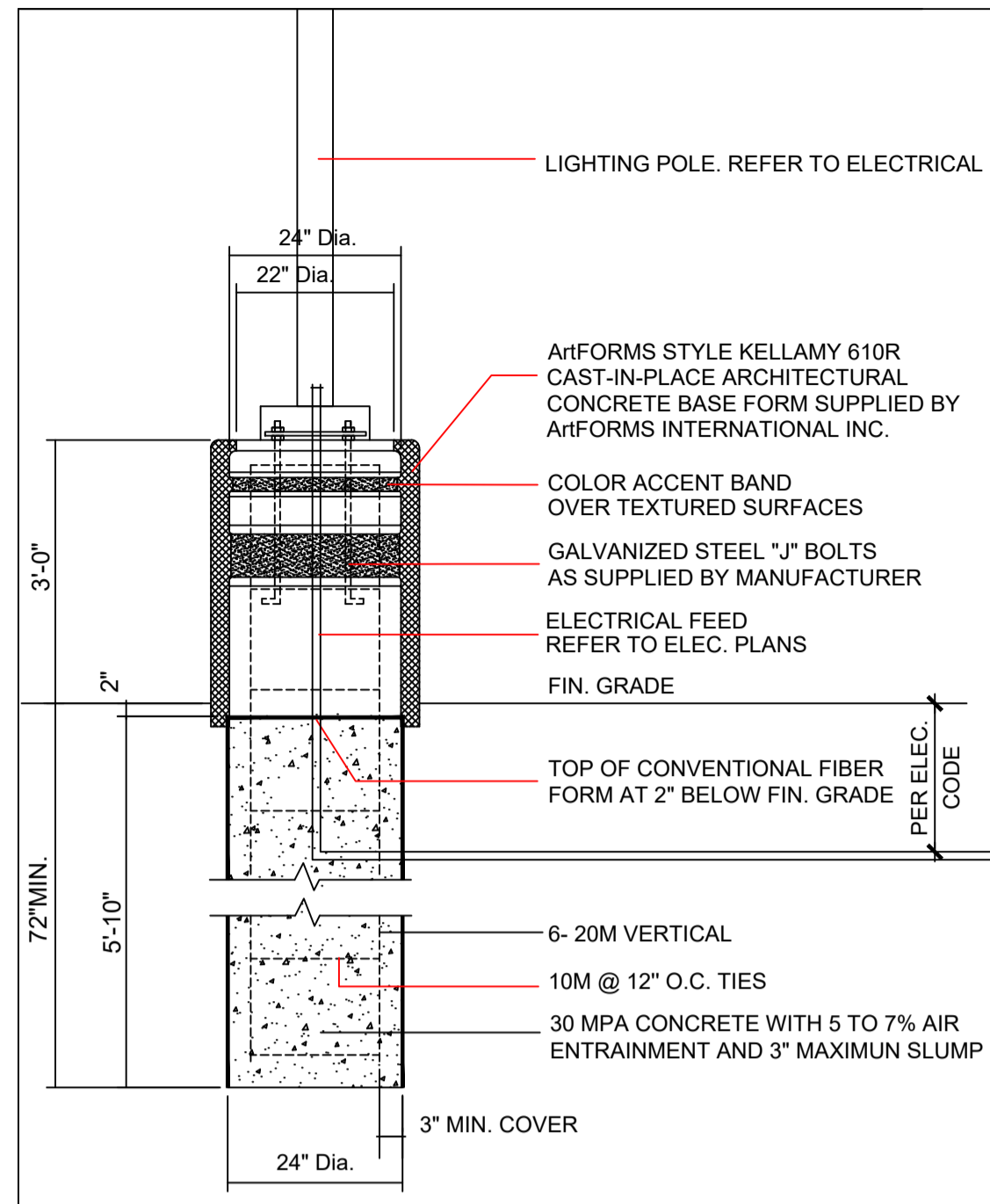

**LIGHT STANDARD BASE DETAIL**  
N.T.S.

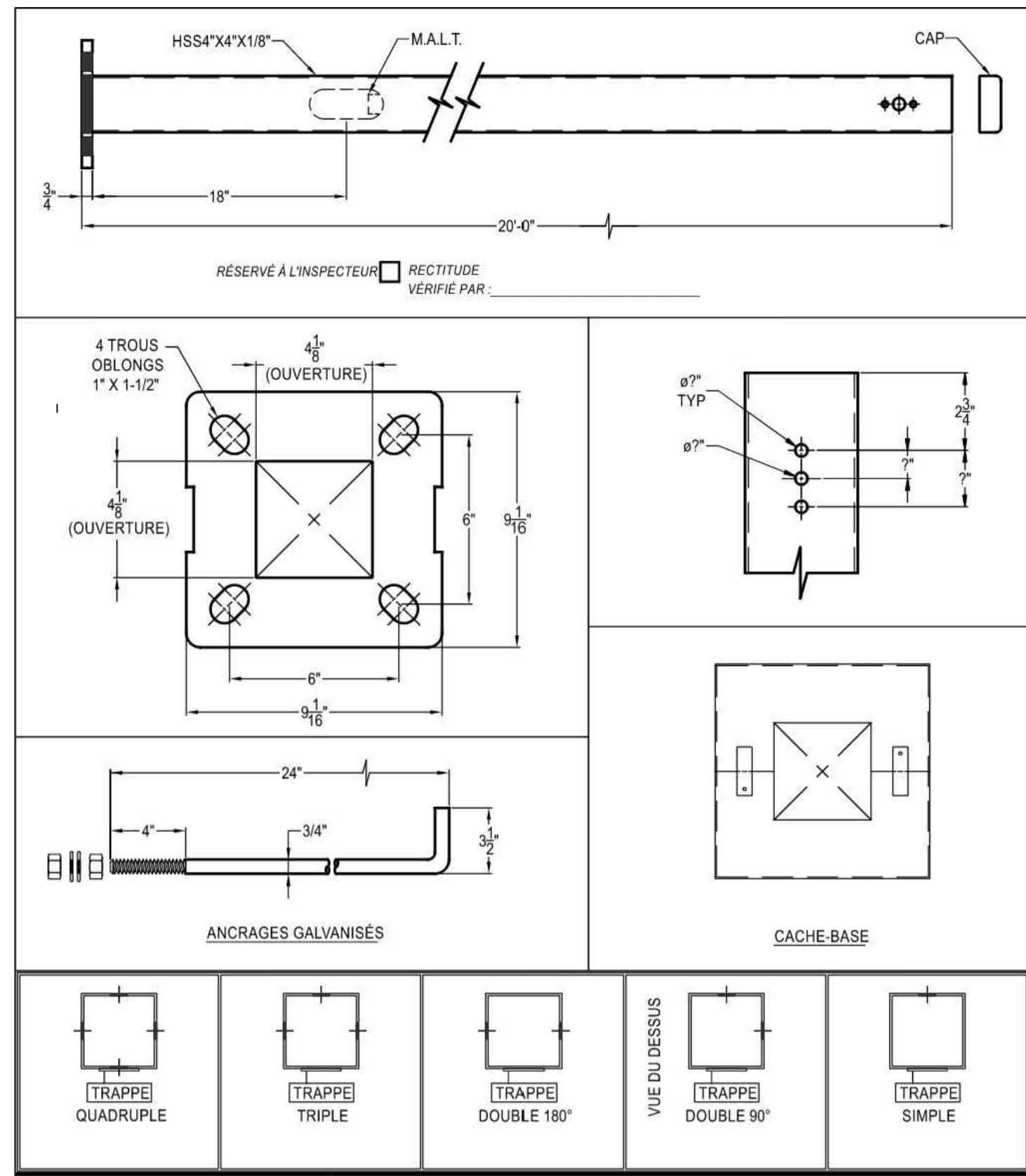

**LIGHT STANDARD BASE ANCHOR CAGE DETAIL (SUPPLIED BY OWNER)**  
N.T.S.

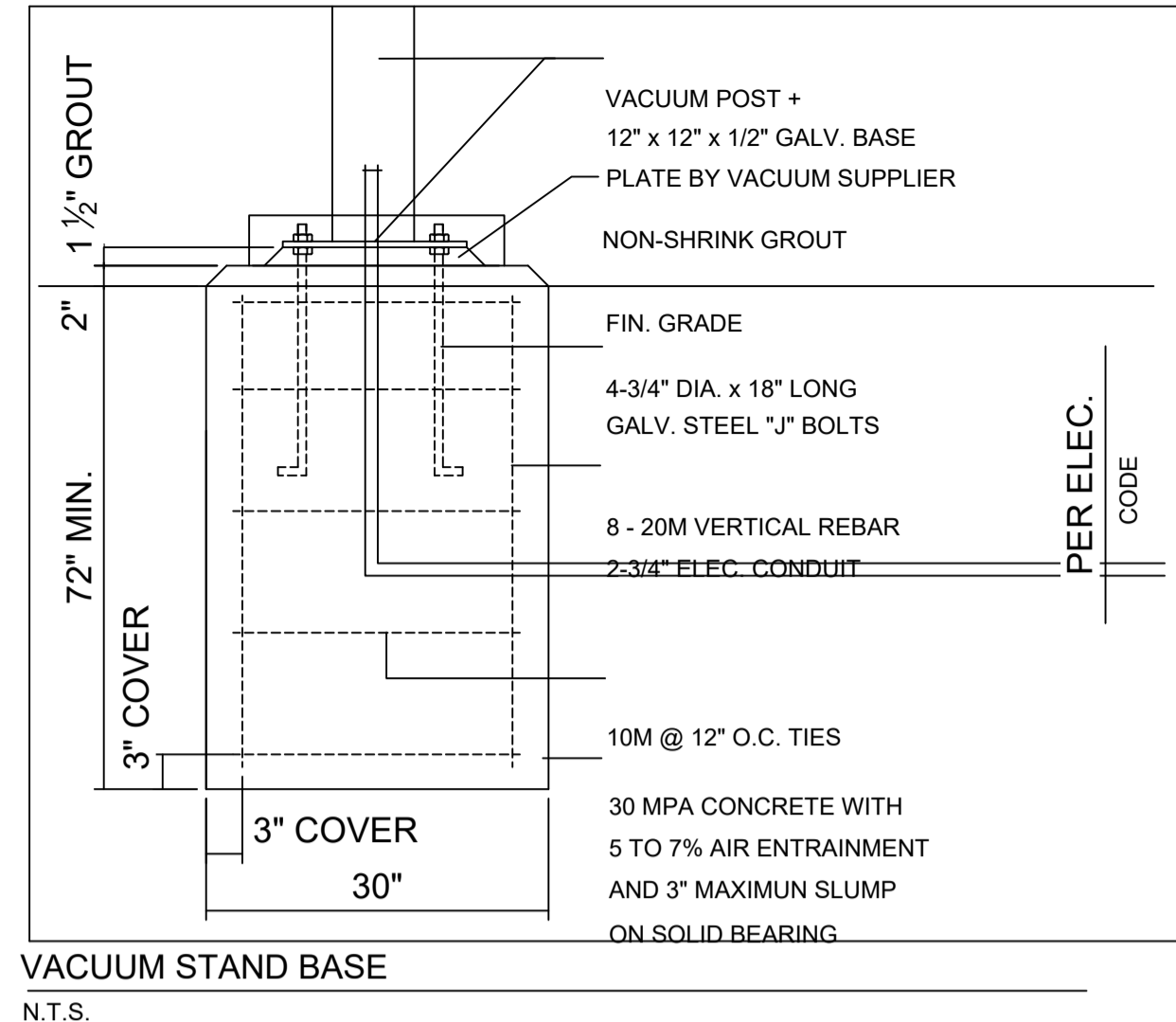

**VACUUM STAND BASE**  
N.T.S.

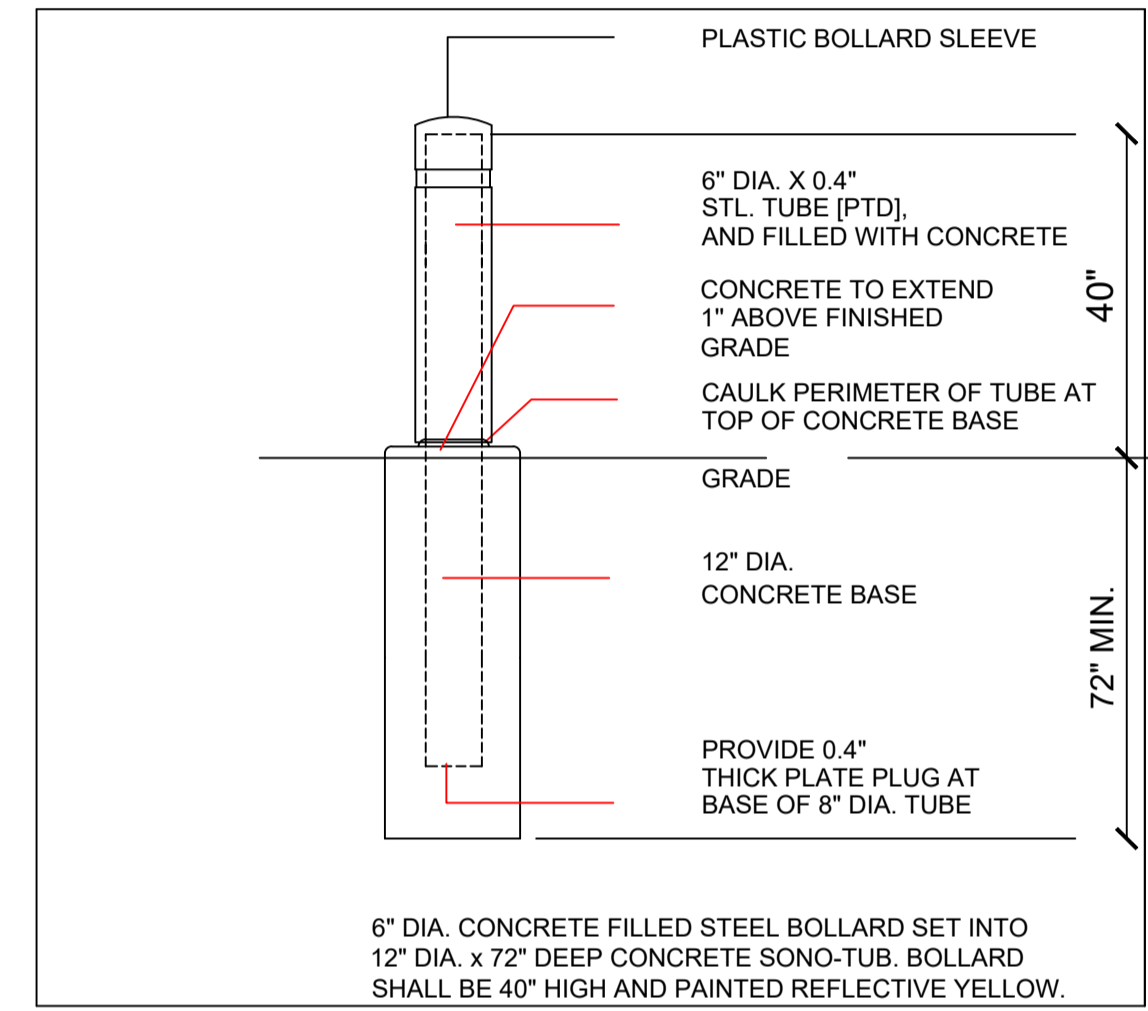

**BOLLARD DETAIL**  
N.T.S.

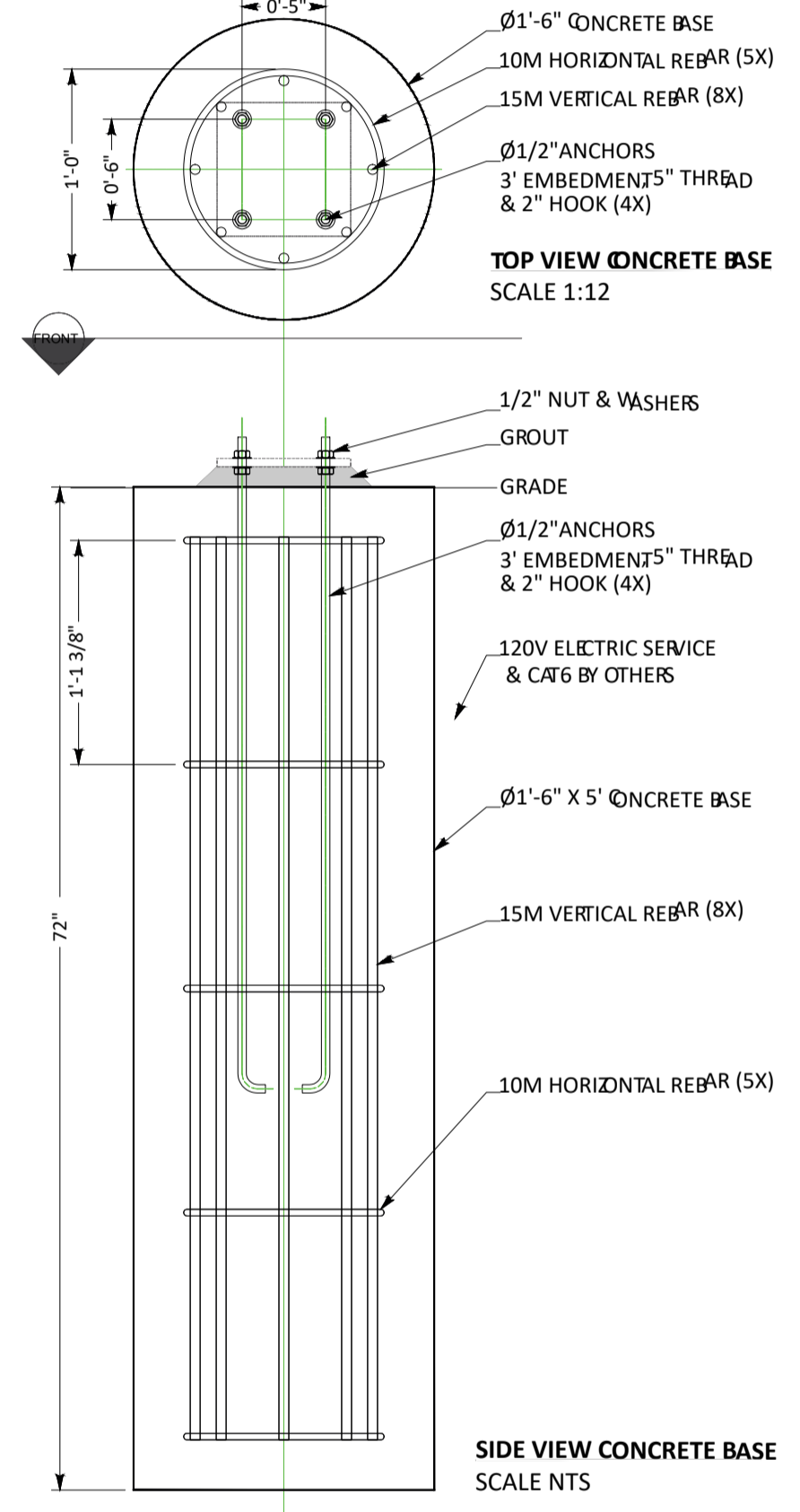

**ASSISTANCE INTERCOM STATIONS**  
N.T.S.

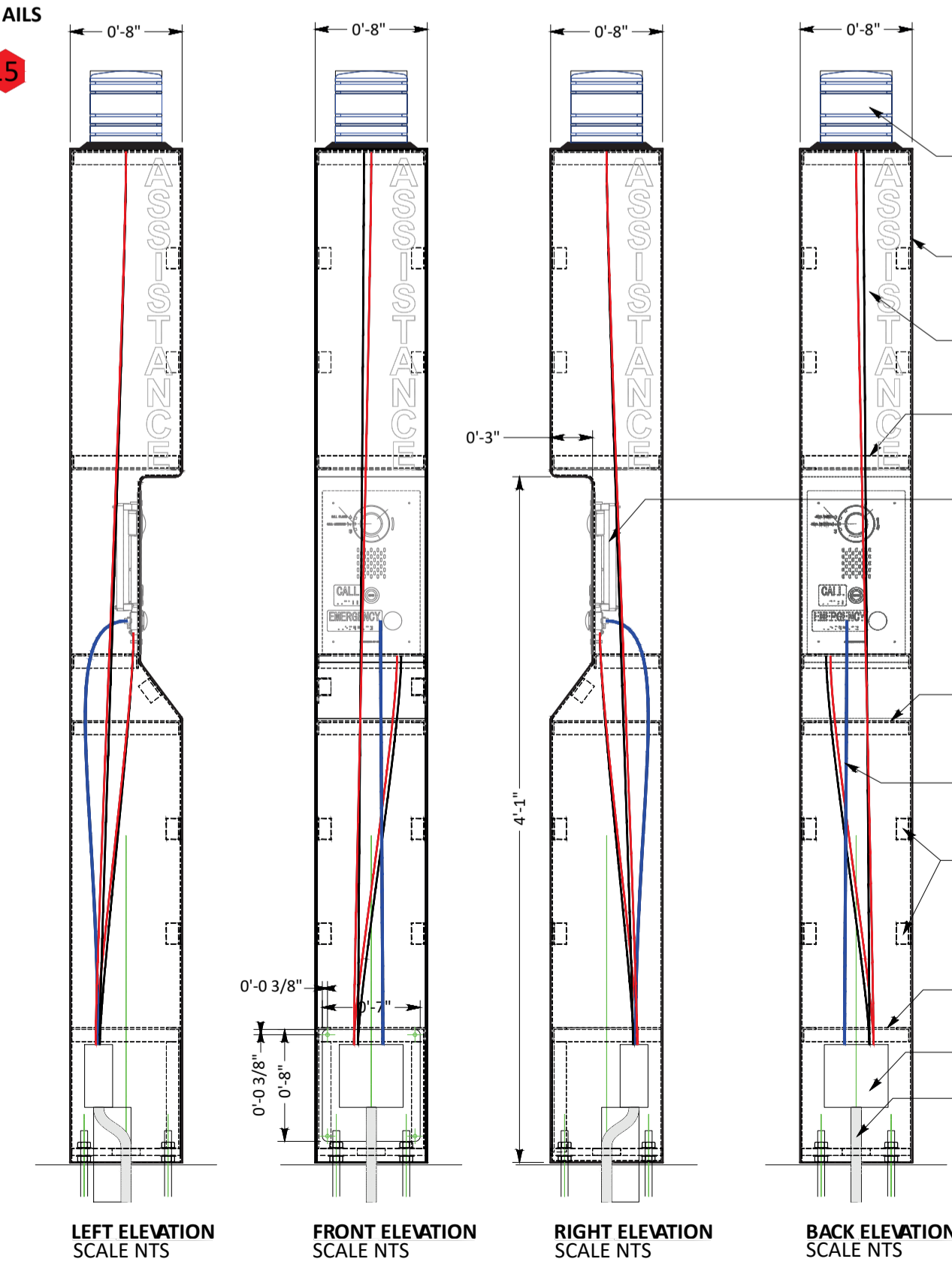

**ASSISTANCE INTERCOM STATIONS**  
N.T.S.

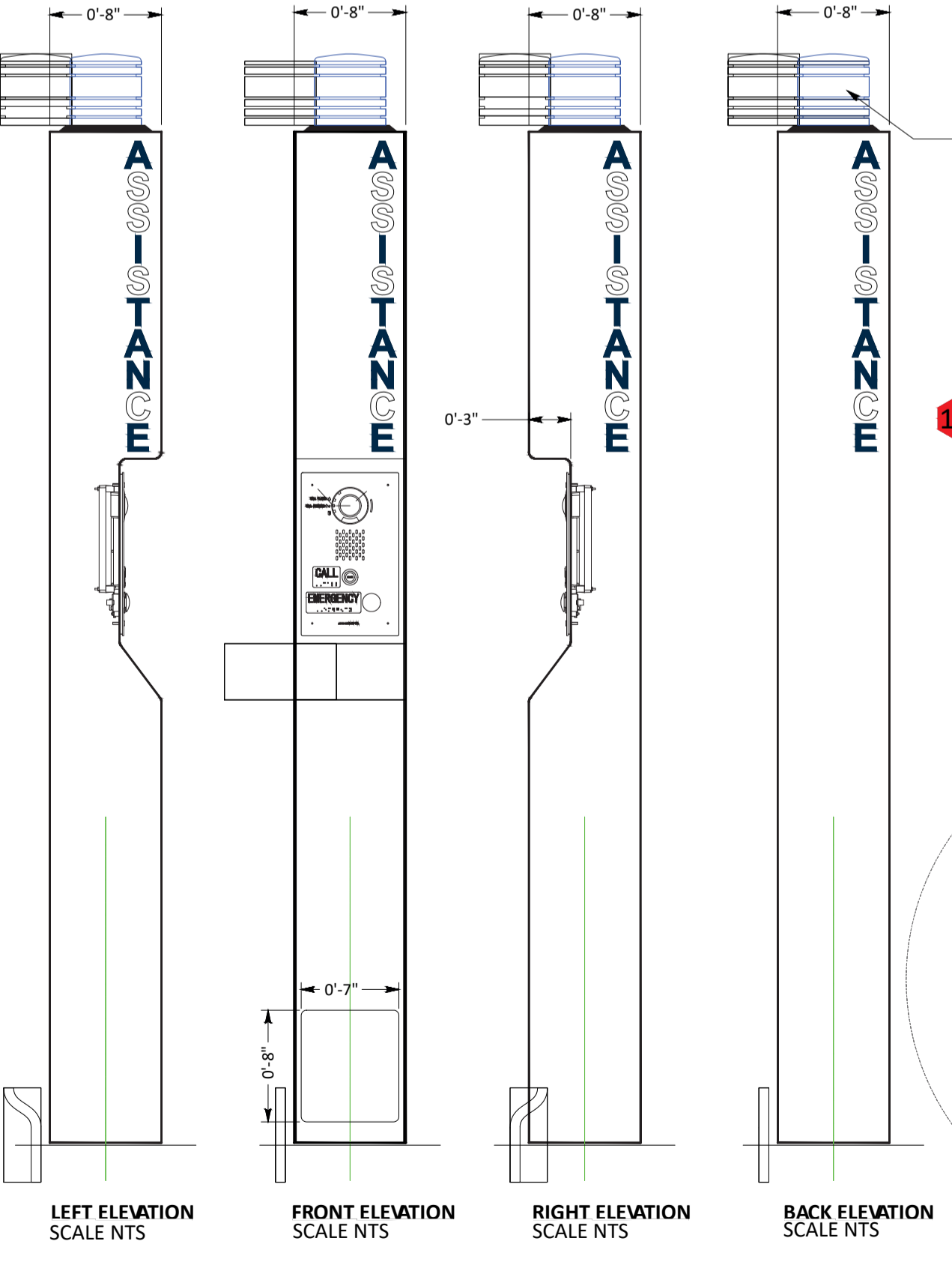
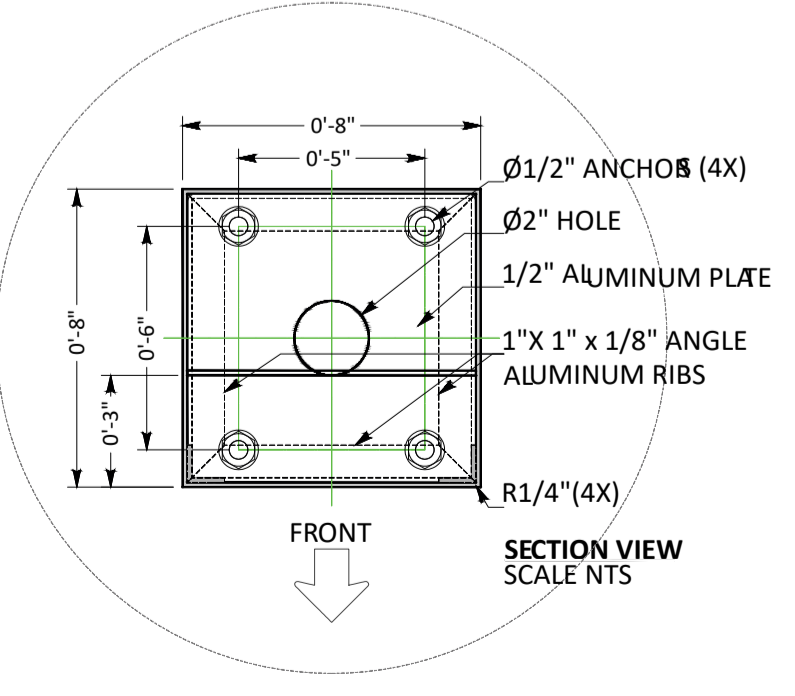

**ASSISTANCE INTERCOM STATIONS**  
N.T.S.

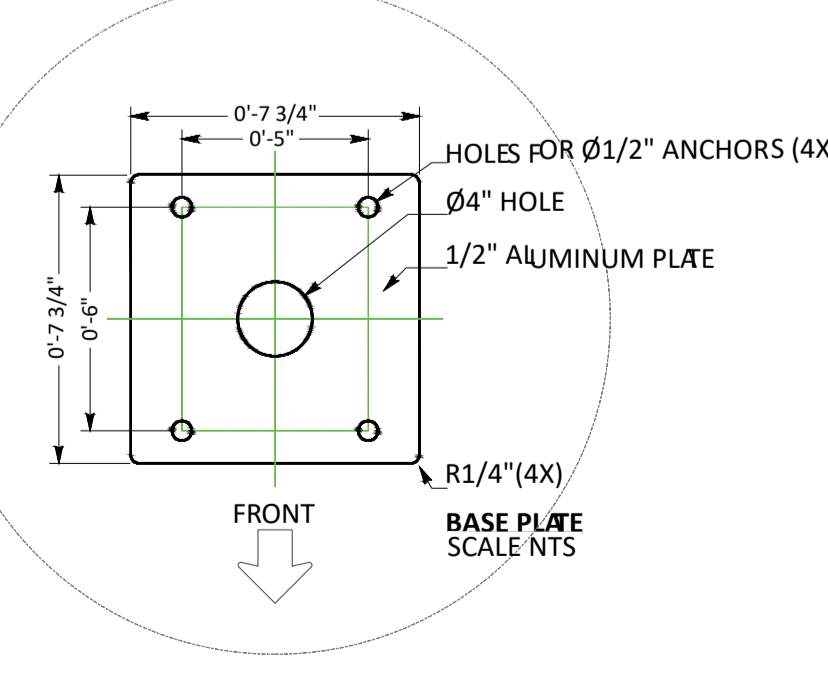

NOTE: DETAIL TO BE VERIFIED AND STAMPED BY A STRUCTURAL ENGINEER PRIOR TO CONSTRUCTION

**USE AND INTERPRETATION OF DRAWINGS**

GENERAL CONDITIONS OF THE CONTRACT FOR CONSTRUCTION ARE PART OF THE CONTRACT DOCUMENTS AND DESCRIBE USE AND INTENT OF THE DRAWING. THE CONTRACT DOCUMENTS INCLUDE NOT ONLY THE DRAWINGS, BUT ALSO THE OWNER-CONTRACTOR AGREEMENTS, CONDITIONS OF THE CONTRACT, THE SPECIFICATIONS, ADDENDA, AND MODIFICATIONS ISSUED AFTER EXECUTION OF THE CONTRACT. THESE CONTRACT DOCUMENTS ARE COMPLEMENTARY, AND WHAT IS REQUIRED BY ANY ONE SHALL BE BINDING AS REQUIRED BY ALL. WORK NOT COMPLETELY DELINEATED HEREON SHALL BE CONSTRUCTED OF THE SAME MATERIALS AND DETAILED SIMILARLY AS WORK SHOWN MORE COMPLETELY ELSEWHERE IN THE CONTRACT DOCUMENTS.

BY USE OF THE DRAWINGS FOR CONSTRUCTION OF THE PROJECT, THE OWNER CONFIRMS THAT HE HAS REVIEWED AND APPROVED THE DRAWINGS. THE CONTRACTOR CONFIRMS THAT HE HAS VISITED THE SITE, FAMILIARIZED HIMSELF WITH THE LOCAL CONDITIONS, VERIFIED FIELD DIMENSIONS AND CORRELATED HIS OBSERVATIONS WITH THE REQUIREMENTS OF THE CONTRACT DOCUMENTS.

AS INSTRUMENTS OF SERVICE, ALL DRAWINGS, SPECIFICATIONS, CADD FILES OR OTHER ELECTRONIC MEDIA AND COPIES THEREOF FURNISHED BY THE ENGINEER ARE HIS PROPERTY. THEY ARE TO BE USED ONLY FOR THIS PROJECT AND ARE NOT TO BE USED ON ANY OTHER PROJECT, INCLUDING REPEATS OF THE PROJECT. CHANGES TO THE DRAWINGS MAY ONLY BE MADE BY THE ENGINEER.

UNLESS THE REVISION TITLE IS ISSUED FOR CONSTRUCTION, THESE DRAWINGS SHALL BE CONSIDERED PRELIMINARY AND SHALL NOT BE USED AS A CONSTRUCTION DOCUMENT.

THESE DRAWINGS ILLUSTRATE THE WORK TO BE DONE. THE ENGINEER IS NOT RESPONSIBLE FOR THE MEANS, METHODS, TECHNIQUES, SEQUENCES, AND PROCEDURES USED TO DO THE WORK, OR THE SAFETY ASPECTS OF CONSTRUCTION, AND NOTHING ON THESE DRAWINGS EXPRESSED OR IMPLIED CHANGES THIS CONDITION. CONTRACTOR SHALL DETERMINE ALL CONDITIONS AT THE SITE AND SHALL BE RESPONSIBLE FOR KNOWING HOW THEY AFFECT THE WORK. SUBMITTAL OF A BID TO PERFORM THIS WORK IS ACKNOWLEDGEMENT OF THE RESPONSIBILITIES, AND THAT THEY HAVE BEEN FULLY CONSIDERED IN PLANNING OF THE WORK, AND THE BID PRICE. NO CLAIMS FOR EXTRA CHARGES DUE TO THESE CONDITIONS WILL BE FORTCOMING.

UNAUTHORIZED CHANGES:

IN THE EVENT THE CLIENT, THE CLIENT'S CONTRACTORS OR SUBCONTRACTORS, OR ANYONE FOR WHOM THE CLIENT IS LEGALLY LIABLE MAKES OR PERMITS TO BE MADE ANY CHANGES TO ANY REPORTS, PLANS, SPECIFICATIONS OR OTHER CONSTRUCTION DOCUMENTS PREPARED BY LRL ASSOCIATES LTD. (LRL) WITHOUT OBTAINING LRL'S PRIOR WRITTEN CONSENT, THE CLIENT SHALL ASSUME FULL RESPONSIBILITY FOR THE RESULTS OF SUCH CHANGES. THEREFORE THE CLIENT AGREES TO WAIVE ANY CLAIM AGAINST LRL AND TO RELEASE LRL FROM ANY LIABILITY ARISING DIRECTLY OR INDIRECTLY FROM SUCH UNAUTHORIZED CHANGES.

IN ADDITION, THE CLIENT AGREES TO THE FULLEST EXTENT PERMITTED BY LAW, TO INDEMNIFY AND HOLD HARMLESS LRL FROM ANY DAMAGES, LIABILITIES OR COST, INCLUDING REASONABLE ATTORNEY'S FEES AND COST OF DEFENSE, ARISING FROM SUCH CHANGES.

THE CLIENT AGREES TO INCLUDE IN ANY CONTRACTS FOR CONSTRUCTION APPROPRIATE LANGUAGE THAT PROHIBITS THE CONTRACTOR OR ANY SUBCONTRACTORS OF ANY TIER FROM MAKING ANY CHANGES OR MODIFICATIONS TO LRL'S CONSTRUCTION DOCUMENTS WITHOUT THE PRIOR WRITTEN APPROVAL OF LRL AND THAT FURTHER REQUIRES THE CONTRACTOR TO INDEMNIFY BOTH LRL AND THE CLIENT FROM ANY LIABILITY OR COST ARISING FROM SUCH CHANGES MADE WITHOUT SUCH PROPER AUTHORIZATION.

GENERAL NOTES:

EXISTING SERVICES AND UTILITIES SHOWN ON THESE DRAWINGS ARE TAKEN FROM THE BEST AVAILABLE RECORDS, BUT MAY NOT BE COMPLETE OR TO DATE. CONTRACTOR SHALL VERIFY IN FIELD FOR LOCATION AND ELEVATION OF PIPES AND CHECK WITH THE UTILITY COMPANIES BEFORE DIGGING OR PERFORMING WORK.

CONTRACTOR IS ADVISED TO COLLECT INFORMATION ON SOIL CONDITIONS BEFORE START OF CONSTRUCTION.

THE ENGINEER WAIVES ANY AND ALL RESPONSIBILITY AND LIABILITY FOR PROBLEMS WHICH ARISE FROM FAILURE TO FOLLOW THESE PLANS, SPECIFICATIONS AND THE DESIGN INTENT, CONVEY OR FOR PROBLEMS WHICH ARISE FROM OTHERS' FAILURE TO OBTAIN AND/OR FOLLOW THE ENGINEER'S GUIDANCE WITH RESPECT TO ANY ERRORS, OMISSIONS, INCONSISTENCIES AMBIGUITIES OR CONFLICTS WHICH ARE ALLEGED.

CONTRACTOR TO VERIFY ALL DIMENSIONS AND NOTIFY THE ENGINEER OF ANY DISCREPANCIES BEFORE WORK COMMENCES. DO NOT SCALE DRAWINGS.

**NOT FOR CONSTRUCTION TENDER OR PERMIT**

No.	REVISIONS	BY	DATE
01	ISSUED FOR APPROVAL	M.L.	22 APR 2022

NOT AUTHENTIC UNLESS SIGNED AND DATED

**LRJ**  
ENGINEERING | INGENIERIE  
5430 Canotek Road | Ottawa, ON, K1J 9G2  
www.lrl.ca | (613) 842-3434

CLIENT  
**HALO CAR WASH INC.**

DESIGNED BY: M.L. / P.P. DRAWN BY: M.L. APPROVED BY: M.B.

PROJECT  
**HALO CAR WASH**  
3535 BORRISOKANE RD  
BARRHAVEN, ON

DRAWING TITLE  
**CONSTRUCTION DETAIL PLAN**

PROJECT NO.  
210691

DATE  
JANUARY 2022

**C902**

**APPENDIX F**  
**Survey, As-Builts**



TOPOGRAPHICAL PLAN OF SURVEY OF  
**PART OF LOT 11**  
**CONCESSION 3 (RIDEAU FRONT)**  
**Geographic Township of Nepean**  
**CITY OF OTTAWA**  
 Surveyed by Annis, O'Sullivan, Vollebek Ltd.

Scale 1 : 400

**Metric**  
 DISTANCES SHOWN ON THIS PLAN ARE IN METRES AND  
 CAN BE CONVERTED TO FEET BY DIVIDING BY 0.3048

**Surveyor's Certificate**  
 I CERTIFY THAT :  
 1. This survey and plan are correct and in accordance with the Surveys  
 Act and the Surveyors Act and the regulations made under them.  
 2. The survey was completed on the 19th day of January, 2022.

Date: Jan 21/22  
 T. Hartwick  
 Ontario Land Surveyor

**Notes & Legend**

Symbol	Denotes	Description
□	"	Survey Monument Planted
■	"	Survey Monument Found
SIB	"	Standard Iron Bar
SSIB	"	Short Standard Iron Bar
IB	"	Iron Bar
CC	"	Cut Cross
(WIT)	"	Witness
Meas.	"	Measured
(AOG)	"	Annis, O'Sullivan, Vollebek Ltd.
(PI)	"	Plan 4R-33597
(P2)	"	(AOG) Plan dated October 29, 2021.
— OHW —	"	Overhead Wires
CSP	"	Corrugated Steel Pipe
CPP	"	Corrugated Plastic Pipe
CCP	"	Concrete Pipe
CLF	"	Chain Link Fence
PWF	"	Post and Wire Fence
BOS	"	Bottom of Slope
TOS	"	Top of Slope
DC	"	Ditch Centerline
Inv.	"	Invert
RWT	"	Timber Retaining Wall
o WP	"	Wood Pole
o UP	"	Utility Pole
o AN	"	Anchor
o	"	Diameter
+ 65.00	"	Location of Elevations
+ 65.00*	"	Top of Retaining Wall Elevation

Distances shown on this plan are ground distances and can be converted to grid distances by multiplying by the combined scale factor of 0.999933.

Bearings are grid, derived from Can-Net 2016 Real Time Network GPS observations referenced to Specified Control Points 01919791338 and 01919871649, MTM Zone 9 ( 76°30' West Longitude ) NAD-83 (original).

ASSOCIATION OF ONTARIO  
 LAND SURVEYORS  
 PLAN SUBMISSION FORM  
**V-22497**  
  
 THIS PLAN IS NOT VALID UNLESS  
 IT IS AN EMBOSSED ORIGINAL  
 COPY ISSUED BY THE SURVEYOR  
 In accordance with  
 Regulation 1026, Section 29 (3).

© Annis, O'Sullivan, Vollebek Ltd. 2022. "THIS PLAN IS PROTECTED BY COPYRIGHT"  
**ANNIS, O'SULLIVAN, VOLLEBEK LTD.**  
 14 Concourse Gate, Suite 500  
 Nepean, Ont. K2E 7S6  
 Phone: (613) 727-0850 / Fax: (613) 727-1079  
 Email: Nepean@aosvll.com  
 Job No. 22410-21 Borrisokane January 21, 2022(2)

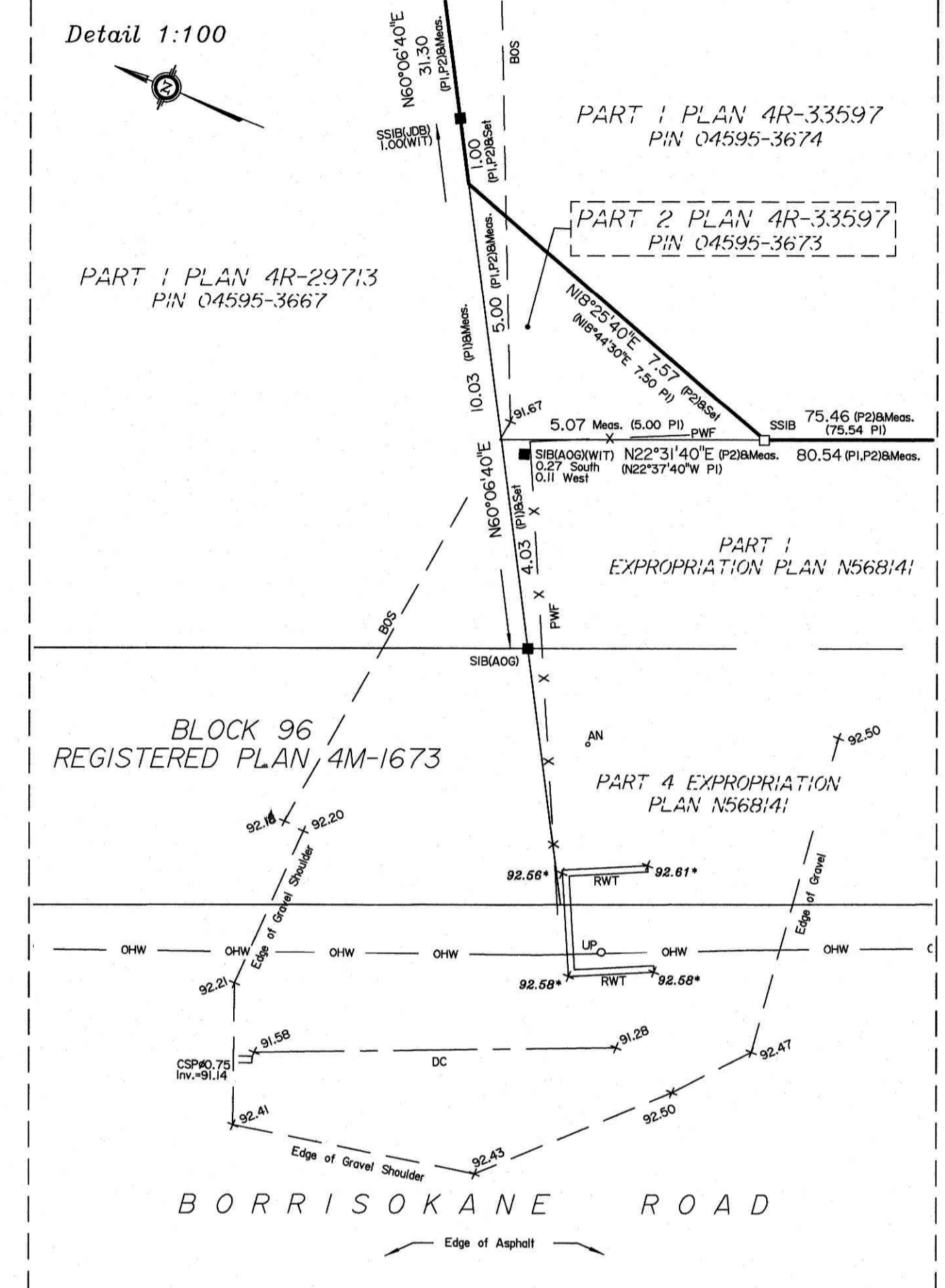
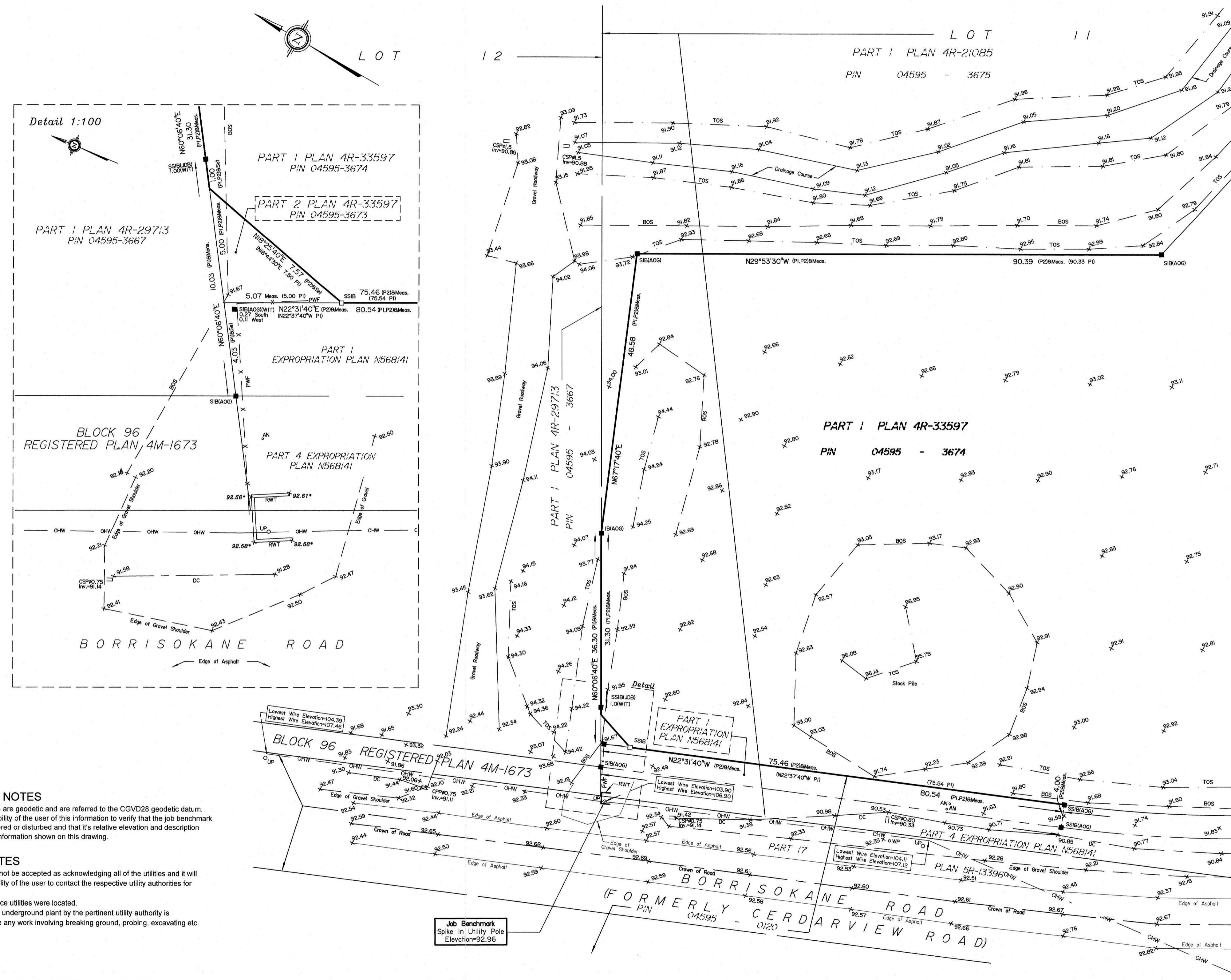

- ELEVATION NOTES**
- Elevations shown are geodetic and are referred to the CGVD28 geodetic datum.
  - It is the responsibility of the user of this information to verify that the job benchmark has not been altered or disturbed and that its relative elevation and description agrees with the information shown on this drawing.
- UTILITY NOTES**
- This drawing cannot be accepted as acknowledging all of the utilities and it will be the responsibility of the user to contact the respective utility authorities for confirmation.
  - Only visible surface utilities were located.
  - A field location of underground plant by the pertinent utility authority is mandatory before any work involving breaking ground, probing, excavating etc.

Job Benchmark  
 Spike In Utility Pole  
 Elevation=92.96

N:\2021\22410-21\_Borrisokane\_Rd\_Topog\Aerials\Topo\Aerials\Topo\Borrisokane January 21, 2022(2).dwg, 2022-01-21 1:46:18 PM