

2022-03-08

Scott Corbett, BA, LEED Green Associate
Planning Assistant, Corbett Land Strategies
5045 South Service Road, Suite 301
Burlington, Ontario | L7L 5Y7
P: 905-484-2706
E: scott@corbettlandstrategies.ca

**Corbett Land Strategies – 125 Colonnade
Stationary Noise Study**

Dear Scott,

This report assesses the environmental noise impact anticipated from a variety of mechanical equipment to be installed at 125 Colonnade to other residential and commercial spaces in the neighbourhood. The noise impact from mechanical equipment must not exceed the City of Ottawa Noise Bylaw limit of 50 dBA during the day and the City of Ottawa Environmental Noise Control Guidelines (ENCG) limit of 45 dBA at night. The ENCG complies with the Ontario Ministry of Environment NPC-300 Guidelines.

This report is based on architectural drawings, mechanical drawings, and sound data received from the design team. It considers the noise impact from 14 mechanical units to be installed atop different buildings which are part of an expansion project at 125 Colonnade. These consist of a condenser unit, two rooftop cooling units, and 11 exhaust fans to the exterior.

Using the provided information, we have constructed an environmental noise model to predict sound pressure levels at the locations of nearby offices and residences resulting from the noise generated by the new mechanical equipment located at 125 Colonnade. According to the equipment data currently available, we have determined that no noise control measures are needed. Our predictions and noise control measures are described in the report.

Should you have any questions regarding this report, please do not hesitate to contact us.

Sincerely,

Alexandre Fortier, B.Sc.,
Principal

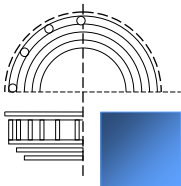

STATE OF THE ART ACOUSTIK INC.

43 – 1010 Polytek Street Ottawa, ON K1J 9J3 www.sota.ca E: sota@sota.ca T: 613-745-2003 F: 613-745-9687

Contents

1.	Introduction & Site Description	3
1.1	Scaled Area Location Plan	3
1.2	Equipment Site Plan & Operation Hours.....	4
1.3	City of Ottawa Noise Bylaw and Ministry of Environment, Conservation and Parks NPC-3005	
2.	Noise Sources & Points of Reception	6
2.1	Significant Noise Sources.....	6
2.2	Points of Reception (PORs).....	7
3.	Methodology Used in Noise Impact Calculation	8
3.1	Procedure Used to Assess Noise Impact at Each Point of Reception.....	8
3.2	Other Parameters/Assumptions Used in Calculations	8
4.	Acoustic Assessment.....	9
4.1	Results with Current Selections.....	10
4.2	Noise Control Measures and Recommendations.....	11
5.	Conclusion	11

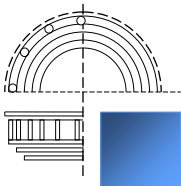

1. Introduction & Site Description

State of the Art Acoustik Inc. has been commissioned by Corbett Land Strategies to complete a stationary noise study for an expansion project at 125 Colonnade Rd. The development is located near both commercial and residential buildings.

1.1 Scaled Area Location Plan

Figure 1.1 below shows the location of 125 Colonnade, the new structures being developed, and the surrounding area. Adjacent noise sensitive buildings to the development sites include commercial office spaces to the north, west, and south, as well as residential buildings to the east.

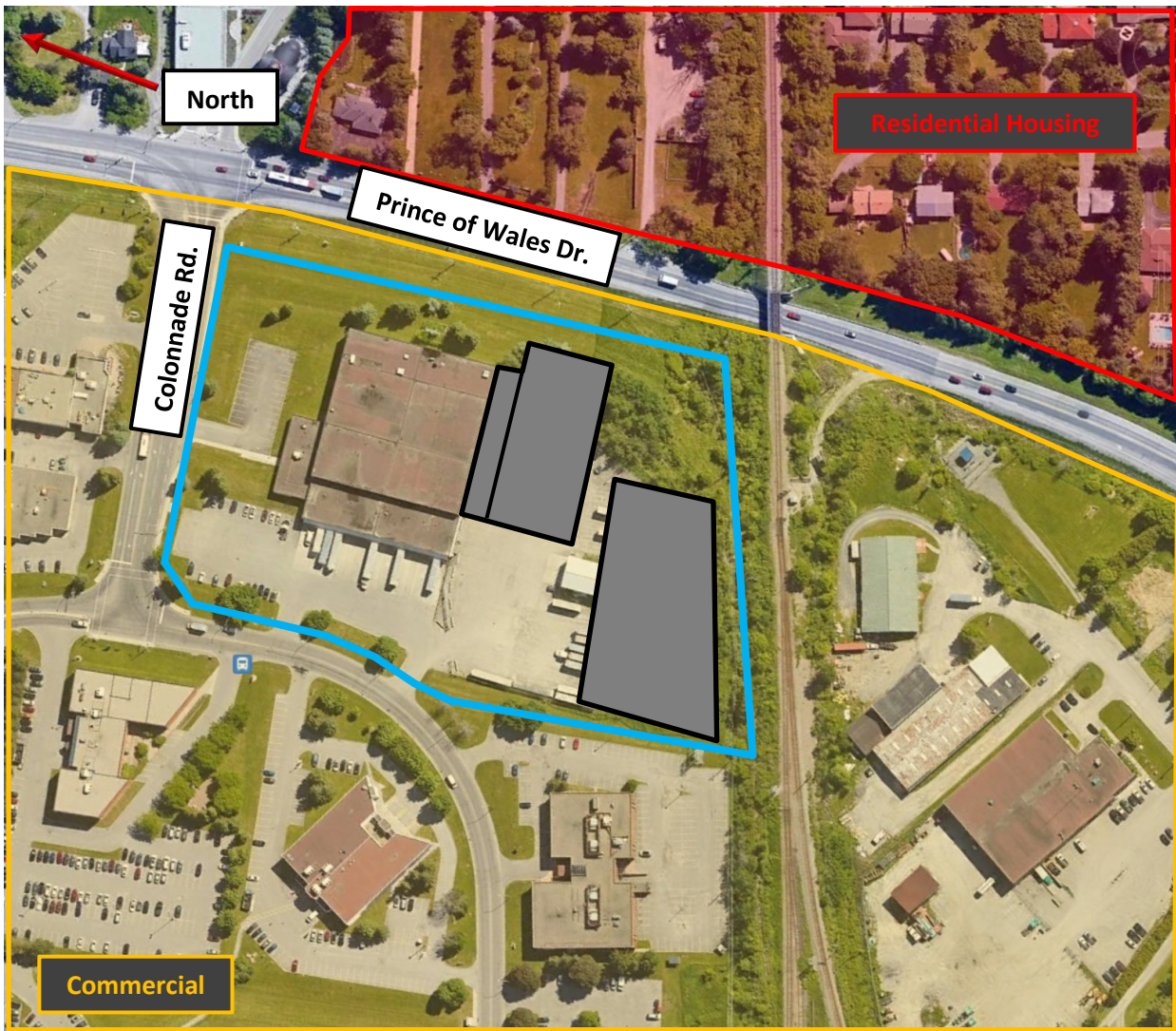
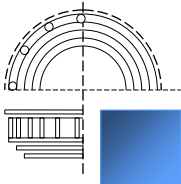

Figure 1.1 – Satellite view of 125 Colonnade and the surrounding area, showing nearby commercial and residential noise sensitive points of reception. The new structures associated with the expansion are indicated by the grey boxes. The approximate property of 125 Colonnade is outlined in blue.



1.2 Equipment Site Plan & Operation Hours

The sources considered in this assessment of the stationary noise to nearby structures include the condensing unit (CU-01), two rooftop cooling units (RTU-01, RTU-02), and several exhaust fans (EF-01 through EF-11). No other pieces of exterior mechanical equipment are scheduled for installation.

In accordance with the predictable worst-case operating scenario, all exterior mechanical elements are assumed to be in constant operation, under a full load. In practice, none of these items are likely to constantly operate at maximum capacity.

Figure 1.2 below shows the latest plans in order to identify the locations of the sound generating equipment. CU-01 is located on the south-west corner of the proposed 3-storey building. RTU-01 and RTU-02 are located on the south-west corner of the proposed 1-storey building. EF-01 through EF-03 are located on the south side of the proposed 1-storey building, and EF-04 through EF-11 are located on the south side of the proposed 3-storey building.

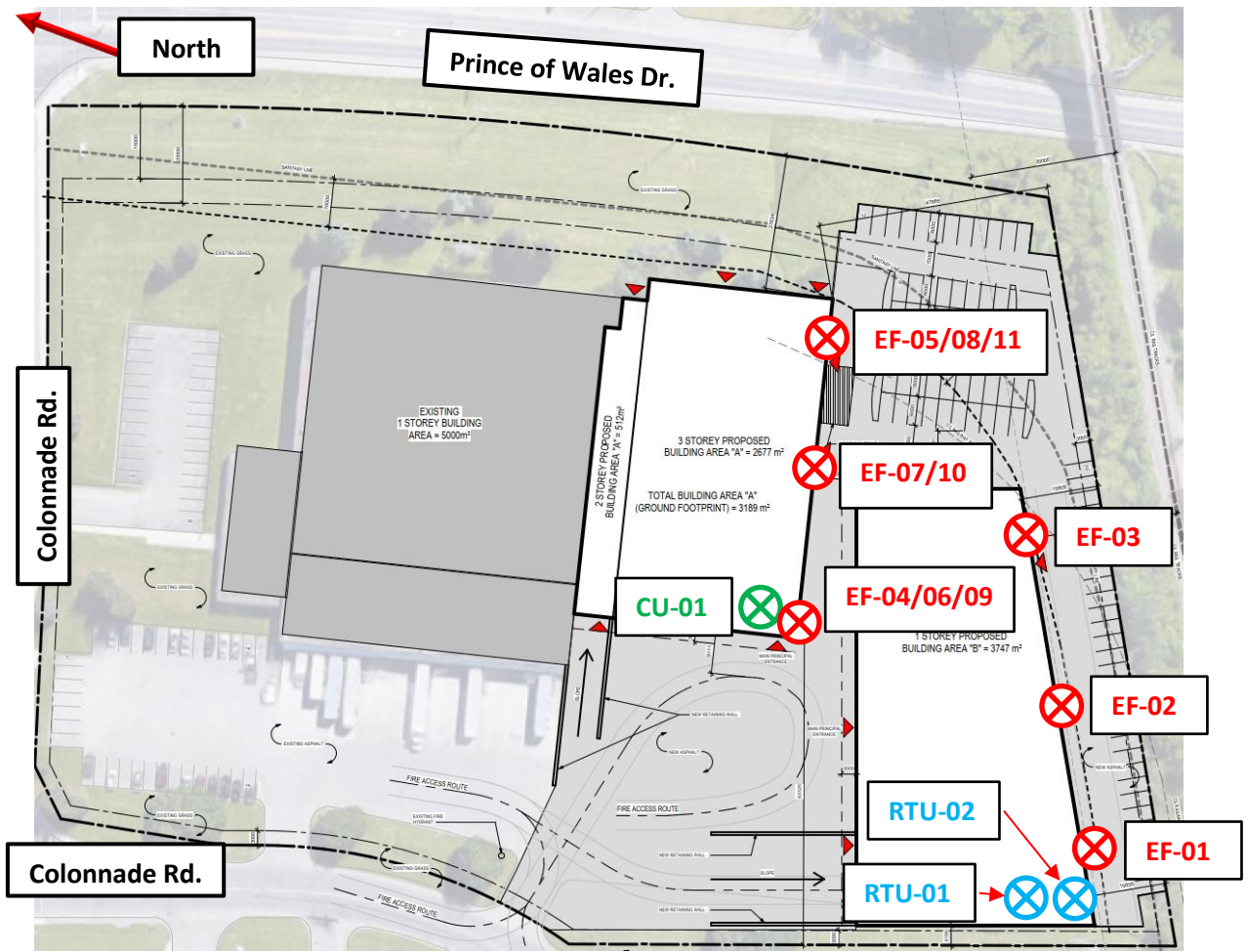
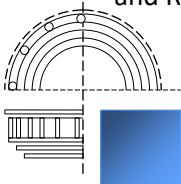

Figure 1.2 - 125 Colonnade plan view, showing equipment layout. CU-01 indicated with green. RTU-01 and RTU-02 indicated with blue. EF-01 through EF-11 indicated with red.



1.3 City of Ottawa Noise Bylaw and Ministry of Environment, Conservation and Parks NPC-300

The City of Ottawa Noise Bylaw has the same limit as the Ministry of Environment, Conservation, and Parks (MECP) NPC-300 for daytime permissible Sound Pressure Level (SPL) at a noise sensitive location in a Class 1 area of 50 dBA SPL. The Bylaw is to be used in conjunction with the City of Ottawa Environmental Noise Control Guidelines (ENCG), which are based on the MECP NPC-300 Noise Control Guidelines. The City of Ottawa ENCG requires a 45 dBA SPL at night or ambient noise, whichever is higher.

Therefore, when analyzing equipment for environmental noise studies, all non-emergency equipment in operation must meet the ENCG limit of 50 dBA during the day and 45 dBA at night. When analyzing emergency equipment, which must be tested during the day, the overall limit of emergency and non-emergency equipment must meet the City of Ottawa Bylaw limit of 50 dBA. It should be noted that NPC-300 allows emergency equipment to operate at 5 dBA above these limits, i.e. 55 dBA during the day, for testing and maintenance purposes. However, the City of Ottawa Noise Bylaw does not recognize this exception and requires emergency equipment testing to comply with the 50 dBA limit.

For our analysis, points of reception are chosen based on the principle of the predictable worst-case scenario for noise impact. This allows us to calculate the largest noise impact and mitigate it accordingly.

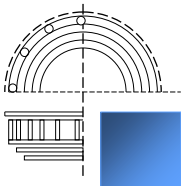

2. Noise Sources & Points of Reception

The following sections describe the noise sources and points of reception included in this report. Locations of equipment are given in **Section 1.2**.

2.1 Significant Noise Sources

This report evaluates 14 significant noise sources. **Table 2.1** lists the sound data used in our evaluation. Sound data was not provided for the condensing unit (manufactured by Daiken). Therefore, representative data from a similarly sized (4-ton) condensing unit, manufactured by Carrier, were used. Cutsheets of sound data for all equipment analyzed are included in the **Appendix**.

Noise Source	Frequency [Hz]								Total [dBA]
	63	125	250	500	1000	2000	4000	8000	
1. Condensing Unit (CU-01)*	78	78	74	73	71	66	62	57	75
2. Rooftop Cooling Units (RTU-01, RTU-02)	90	87	82	81	79	74	71	69	84
3. Exhaust Fans (EF-01 — EF-11)	76	76	75	72	69	68	67	67	76

Table 2.1 – Octave band sound power levels of noise sources.

* Representative data were used for these sources.

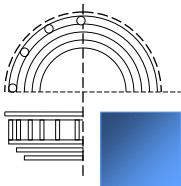

2.2 Points of Reception (PORs)

Noise sensitive buildings adjacent to the development at 125 Colonnade include residential housing to the east, and commercial offices to the north, west, and south. **Figure 2.1** indicates the locations and heights of 3 PORs used to evaluate the local impact of the noise generating equipment. POR 1 is located at 141 Colonnade Rd., POR 2 is located at 20 Rideau Heights Dr., and POR 3 is located at 18 Stephanie Ave. These PORs, shown in **Table 2.2**, were selected due to their proximity to the site and proposed noise sources.

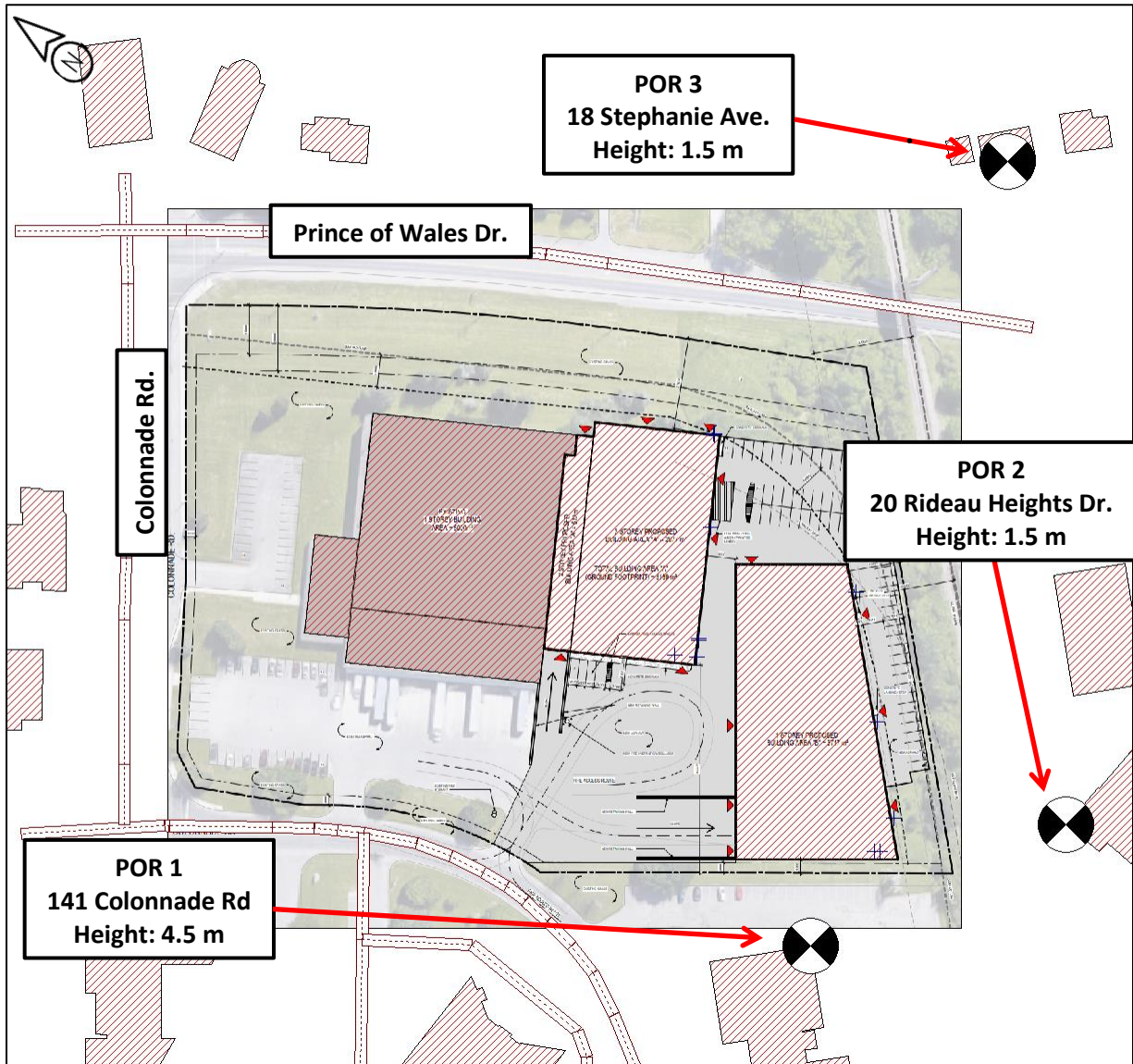
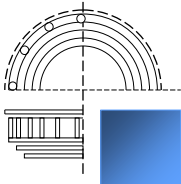

Figure 2.1 – Locations and heights of points of reception (PORs).



POR #	Location	Property Type	Noise Limit (dBA)
1	20 Rideau Heights	Commercial	50
2	141 Colonnade	Commercial	50
3	16 Stephanie Ave	Residential	45

Table 2.2 – Point of Reception (POR) list with applicable noise limits and property type.

The noise limits given in **Table 2.2** correspond to the City of Ottawa Noise Bylaw and NPC-300. For commercial properties, the daytime limit of 50 dBA applies, while for the residential property at POR 3, the nighttime limit of 45 dBA applies.

3. Methodology Used in Noise Impact Calculation

The following sections describe the methodology and software used to model the sound pressure levels at the points of reception due to the noise sources, while considering parameters such as source levels, distance, topography, barriers, and building geometry.

3.1 Procedure Used to Assess Noise Impact at Each Point of Reception

This environmental noise analysis was done using an environmental noise modeling software called CadnaA which references ISO 9613. CadnaA predicts environmental noise through calculations based on a 3D model which uses geometrical, landscape, and topography data, combined with details of the proposed construction and the noise source power levels.

We created a 3D rendering of the neighbourhood around the 125 Colonnade, placed the noise sources in the model at the appropriate locations, and then applied the sound power levels described in this report. The colours on the ground and buildings represent sound pressure levels at those locations. Sound power levels per octave band were entered into CadnaA at the source locations and the resulting sound pressure levels were calculated at the points of reception.

3.2 Other Parameters/Assumptions Used in Calculations

The following table describes the parameters used in the CadnaA model:

Parameter	Value/Condition
Temperature (°C)	10
Relative Humidity (%)	70
All Buildings, Roads and Land Fully Reflective	Absorption Coefficient Alpha = 0
Maximum Order of Reflection	2
No Sub. of Neg. Ground Att.	ON
No Neg. Path Difference	ON

Table 3.1 – Parameters used in CadnaA modeling.

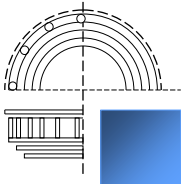

4. Acoustic Assessment

This section summarizes the CadnaA noise mapping results for the sources considered in this report, which consist of the condensing unit, 2 rooftop cooling units, and 11 exterior exhaust fans. **Section 4.1** shows the sound pressure levels generated by all the noise sources with the currently selected or representative equipment described above. **Section 4.2** outlines the recommended noise attenuation measures based on the findings from **Section 4.1**.

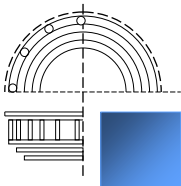

STATE OF THE ART ACOUSTIK INC.

43 – 1010 Polytek Street Ottawa, ON K1J 9J3 www.sota.ca E: sota@sota.ca T: 613-745-2003 F: 613-745-9687

4.1 Results with Current Selections

Figure 4.1 shows the noise prediction grid at a height of 4.5 m for daytime operations, that is, with all noise generating equipment running at full capacity. To meet the daytime target of 50 dBA, there should be no red, purple, or blue at the PORs in the figure. The predicted noise levels at the PORs are displayed in **Figure 4.1** and **Table 4.1**. The dominant noise sources at PORs 1 and 2 are the rooftop cooling units. The dominant noise sources at POR 3 are the rooftop cooling units, and the closest located exterior exhaust fans.

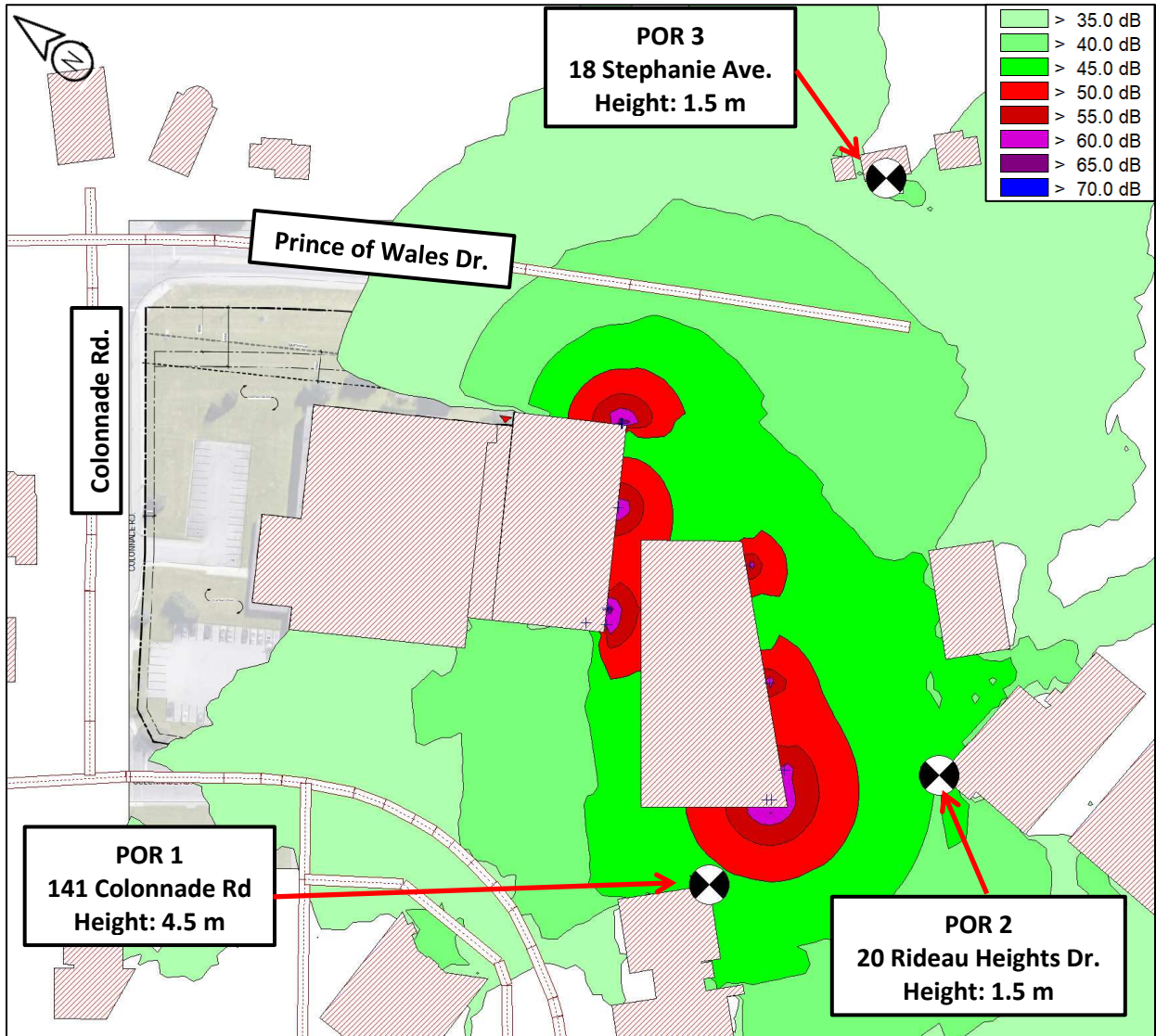
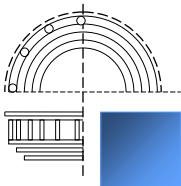

Figure 4.1 – Predicted sound pressure levels in dBA as a result of normal daytime operations. Grid at 4.5 m elevation.



POR #	Location	Property Type	Noise Limit (dBA)	Calculated SPL (dBA)	Limit met?
1	20 Rideau Heights	Commercial	50	48	Yes
2	141 Colonnade	Commercial	50	45	Yes
3	18 Stephanie Ave	Residential	45	38	Yes

Table 4.1 – Predicted sound pressure levels in dBA at each POR.

As indicated in **Table 4.1** above, all PORs are within the allowable noise limits.

4.2 Noise Control Measures and Recommendations

The calculated sound pressure level results shown in **Section 4.1** demonstrate that no noise control measures are required to meet the City of Ottawa ENCG and MOECP NPC-300 requirements.

5. Conclusion

We have modelled and assessed the sound pressure levels in our 3D acoustical model of the expansion project at 125 Colonnade and have found that, given the current mechanical configuration and equipment selection, no noise control measures are required.

Should you have any questions regarding this report, please do not hesitate to contact us.

Sincerely,

Alexandre Fortier, B.Sc.,
Principal

Approved by :

Don Buchan, P.Eng.
Principal
Buchan Lawton Parent Ltd.

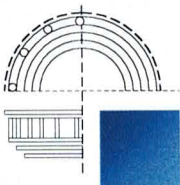

Appendix
Condensing Unit Datasheet
Rooftop Cooling Unit Datasheet
Exhaust Fan Datasheet

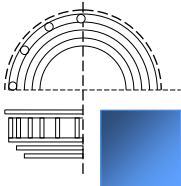

STATE OF THE ART ACOUSTIK INC.

43 - 1010 Polytek Street Ottawa, ON K1J 9J3 www.sota.ca E: sota@sota.ca T: 613-745-2003 F: 613-745-9687

48HC
High Efficiency
Gas Heat/Electric Cooling Packaged Rooftop
3 to 12.5 Nominal Tons



Product Data



C10222



Table 5 – HEATING RATING TABLE - LOW NO_x¹

UNIT	GAS HEAT	LOW NO _x HEAT EXCHANGER	TEMP RISE (DEG F)	THERMAL EFFICIENCY (%)	AFUE (%)	
		INPUT / OUTPUT STAGE 1 (MBH)				
Single Phase	04	LOW	60 / 47	20 – 50	81%	80.6%
		MED	90 / 72	30 – 60	81%	80.6%
		HIGH	–	–	–	–
	05	LOW	60 / 47	20 – 50	81%	80.6%
		MED	90 / 72	30 – 60	81%	80.6%
		HIGH	120 / 97	40 – 70	81%	81.5%
06	LOW	60 / 47	15 – 50	81%	80.6%	
	MED	90 / 72	25 – 60	80%	80.6%	
	HIGH	120 / 97	35 – 70	80%	81.5%	
Three Phase	04	LOW	60 / 47	20 – 50	81%	–
		MED	90 / 72	30 – 60	81%	–
		HIGH	–	–	–	–
	05	LOW	60 / 47	20 – 50	81%	–
		MED	90 / 72	30 – 60	81%	–
		HIGH	120 / 97	40 – 70	81%	–
	06	LOW	60 / 47	15 – 50	81%	–
		MED	90 / 72	25 – 60	80%	–
		HIGH	120 / 97	35 – 70	80%	–

– Not Applicable

NOTE:

1. Units meet California’s South Coast Air Quality Management District (SCAQMD) Low–NO_x emissions requirement of 40 nanograms per joule or less.

Table 6 – SOUND PERFORMANCE TABLE

UNIT	COOLING STAGES	OUTDOOR SOUND (dB) AT 60								
		A–WEIGHTED	63	125	250	500	1000	2000	4000	8000
A04	1	76	78.2	78.0	74.2	73.3	70.6	66.0	62.4	56.9
A05	1	78	84.7	83.6	77.1	74.6	72.3	68.3	64.7	60.9
A06	1	77	87.5	82.5	76.1	73.6	71.3	67.1	64.1	60.0
A07	1	82	90.1	82.6	81.0	79.4	77.0	73.0	70.4	66.7
D08	2	82	90.6	84.3	80.2	79.3	77.1	72.2	67.4	63.7
D09	2	82	88.6	85.0	81.6	79.5	77.4	74.1	71.0	66.3
D11	2	87	85.9	87.9	85.6	84.4	82.8	78.5	74.9	72.5
D12	2	87	85.9	87.9	85.6	84.4	82.8	78.5	74.9	72.5
D14	2	83	89.3	86.0	82.9	80.7	78.5	73.6	69.6	64.5

LEGEND

dB – Decibel

NOTES:

1. Outdoor sound data is measure in accordance with AHRI.
2. Measurements are expressed in terms of sound power. Do not compare these values to sound pressure values because sound pressure depends on specific environmental factors which normally do not match individual applications. Sound power values are independent of the environment and therefore more accurate.
3. A–weighted sound ratings filter out very high and very low frequencies, to better approximate the response of “average” human ear. A–weighted measurements for Carrier units are taken in accordance with AHRI.



COOK



MARK: EF-2,6 REV 1

PROJECT: SELF STORAGE FANS

DATE: 1/7/2020

EWB

Wall Exhaust Fan Extruded Aluminum Propeller Belt Drive

STANDARD CONSTRUCTION FEATURES:

Extruded aluminum propeller - Propeller hub keyed to shaft - Propellers are statically and dynamically balanced - 14 gauge steel venturi - Welded wall base corners - Aluminum supply inlet - Heavy duty steel power assembly - Lorenized powder paint finish - Regreaseable bearings in a cast housing rated at 200,000 hours average life - Adjustable pitch drives through 5 hp - Corrosion resistant fasteners - Oil and heat resistant, static conducting belts - All fans factory adjusted to specified fan RPM.

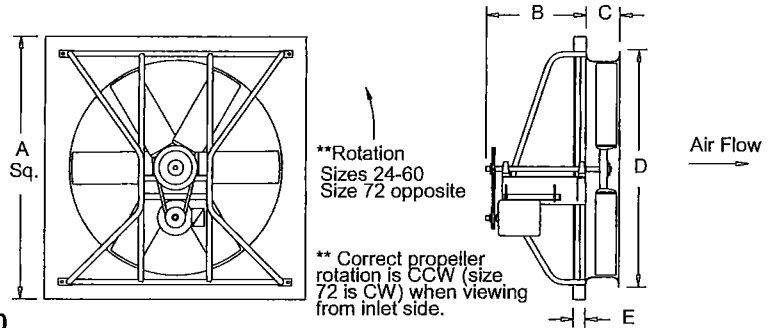

Performance (*Bhp includes 16% drive loss)

Qty	Catalog Number	Flow (L/s)	SP (Pa)	Fan RPM	Power* (KW)	FEG	FEI
6	24EW616B	412	125	946	.174	n/a(<1HP)	n/a(<1HP)

Altitude (m): 387 Temperature (C): 21

Motor Information

KW	RPM	Volts/Ph/Hz	Enclosure	FLA	Mounted
.25	1725	115/1/60	ODP -SE	7.2	Yes

FLA based on NEC (2014) Table 430.248

Sound Data Inlet Sound Power by Octave Band

1	2	3	4	5	6	7	8	LwA	dBA	Sones
76	76	75	72	69	68	67	67	76	64	14.9

Accessories:

- DRIVES (1.5 SE) @ 946 RPM
- DISCONNECT NEMA 1
- GRAVITY SHUTTER (GALV) -33
- WALL COLLAR
- WIREGUARD-MOTOR SIDE
- KNOCKDN WEATHRHHD 45D

Dimensions (millimeters)

A Sq.	919.2
B	508.0
C	168.3
D Dia.	695.3
E	76.2
Wall Opening*	925.5

NOTE: Accessories may affect dimensions shown.

Weight(kgs)***	Shipping	191	Unit	113
----------------	----------	-----	------	-----

* See wire guard or wall collar submittal for accessory wall opening.
 ***Includes fan, motor & accessories.

Fan Curve

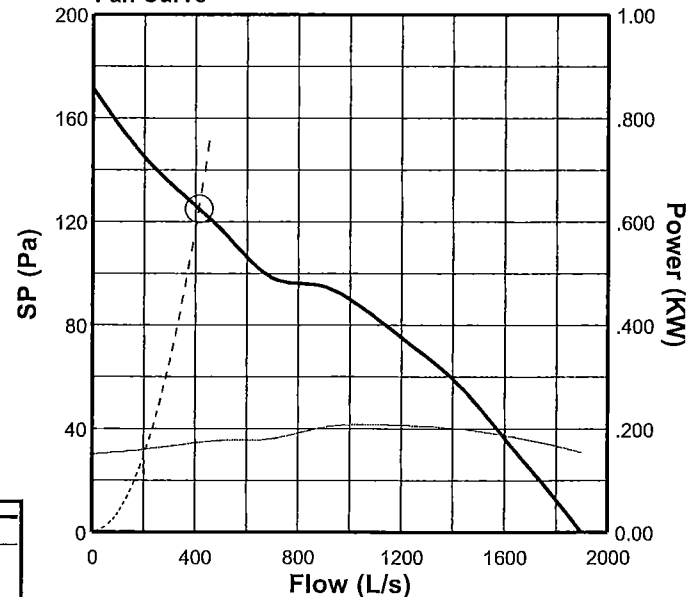

Fan Curve Legend

L/s vs SP	—
L/s vs KW	- - -
Point of Operation	○
System Curve	—



TECHNICAL GUIDE

ZX/ZY/ZQ/ZL SERIES

3 - 12.5 TON

60 HERTZ



AHRI 270 Outdoor Sound Power Levels

Unit (Tons)	Sound Rating ¹ (dB-A)	Octave Bands (Hz)							
		63	125	250	500	1000	2000	4000	8000
ZXA7 (6)	79	85.0	85.0	77.0	75.0	74.0	70.0	66.0	62.0
ZX08 (7.5)	84	87.0	86.0	82.0	80.5	79.5	75.0	70.5	66.5
ZX09 (8.5)	83	91.0	86.0	79.0	79.5	78.0	74.0	70.5	69.0
ZX12 (10)	84	87.5	85.0	81.0	80.0	80.0	74.5	70.0	66.5
ZX14 (12.5)	90	87.5	88.5	85.0	86.0	85.0	81.0	78.5	73.0
ZY04 (3)	79	81.0	86.5	77.0	76.0	75.0	70.5	66.5	63.5
ZY05 (4)	79	84.0	83.0	76.0	75.0	74.0	70.0	66.0	63.5
ZY06 (5)	79	85.0	85.0	78.0	78.0	78.0	73.0	68.0	65.0
ZY07 (6)	84	90.0	87.0	81.5	81.0	79.0	74.5	71.0	69.5
ZYA7 (6)	83	85.0	86.0	81.0	80.0	78.0	73.0	70.0	65.0
ZY08 (7.5)	83	91.5	84.5	79.5	79.5	78.5	74.0	68.5	66.0
ZY09 (8.5)	83	92.0	87.0	81.0	80.5	79.0	74.0	69.0	66.0
ZY12 (10)	87	88.0	88.5	84.5	84.0	82.5	78.5	76.0	73.0
ZQ04 (3)	79	81.5	84.5	76.5	75.0	74.0	69.5	65.5	61.0
ZQ05 (4)	79	82.0	85.0	77.5	75.5	74.0	70.0	66.5	62.0
ZQ06 (5)	79	83.0	83.0	76.0	75.0	75.0	69.5	66.0	63.0
ZL08 (7.5)	82	85.0	86.0	80.0	79.0	78.0	73.0	68.0	64.0
ZL09 (8.5)	82	88.5	83.0	81.0	79.0	78.0	73.5	69.0	65.5
ZL12 (10)	86	82.0	88.5	85.0	82.5	80.5	76.0	73.5	69.5
ZL14 (12.5)	86	84.0	88.5	84.5	83.5	81.0	76.5	73.5	69.5

1. Rated in accordance with AHRI 270 standard.