

© 2023 GOOGLE, MAP DATA © 2023 TELE ATLAS  
**LOCATION PLAN**  
 NTS

**LEGEND**

PROPERTY LINE	---
LIMIT OF CONSTRUCTION	---
ROOF OUTLINE	- - -
BASEMENT OUTLINE	---
PROPOSED INFILTRATION TRENCH	---
PROPOSED GUARDRAIL	---
PROPOSED FENCE	---
PROPOSED GRADE	x 148.22
PROPOSED GRADE (TOP OF WALL)	x 149.39TW
PROPOSED GRADE (BOTTOM OF WALL)	x 148.29BW
PROPOSED TOP OF SWALE	x 148.53TSW
PROPOSED BOTTOM OF SWALE	x 148.43BSW
PROPOSED GRADE (TOP OF CURB)	x 148.53TC
PROPOSED GRADE (BOTTOM OF CURB)	x 148.43BC
EXISTING GRADE	x 149.40EX
PROPOSED STORMWATER MANHOLE	○
PROPOSED SANITARY MANHOLE	●
PROPOSED AREA DRAIN	○
EMERGENCY OVERLAND FLOW ROUTE	---
BOTTOM OF SWALE ROUTE	---

**LIST OF DRAWINGS**

SG-01 (SITE GRADING PLAN)	
SS-01 (SITE SERVING PLAN)	
EC-01 (EROSION CONTROL PLAN)	
DD-01 (DETAIL DRAWINGS)	

**SITE PLAN INFORMATION**  
 HOBIN ARCHITECTURE INCORPORATED  
 63 PAMILLA STREET  
 OTTAWA, ON K1S 3K7  
 TEL: (613) 238-7200  
 FAX: (613) 235-2005  
 Email: mail@hobinarc.com

**SURVEY INFORMATION**  
 ANNIS, O'SULLIVAN, VOLLEBEK LTD.  
 14 CONOURSE GATE, SUITE 500,  
 NEPEAN, ON K2E 7S6  
 TEL: (613) 727-0850  
 FAX: (613) 727-1079  
 EMAIL: Nepean@avotltd.com

**BENCHMARK**  
 ELEVATIONS SHOWN ARE GEODETIC AND ARE REFERRED TO THE COORDINATE GEODETIC DATUM DERIVED FROM VERTICAL CONTROL MONUMENT NO. 3846 HAVING AN ELEVATION OF 69.851 METRES.

*Andrew McCreight*  
**ANDREW MCCREIGHT**  
 MANAGER (A), DEVELOPMENT REVIEW CENTRAL  
 PLANNING, REAL ESTATE & ECONOMIC DEVELOPMENT  
 DEPARTMENT, CITY OF OTTAWA

**APPROVED**  
 By Andrew McCreight at 1:28 pm, May 26, 2023

NO	REVISION	DATE	BY
2	ISSUED FOR SITE PLAN APPLICATION	MAR 27, 2023	NM
1	ISSUED FOR SITE PLAN APPLICATION	JAN 16, 2023	NM



CITY OF OTTAWA

**SITE GRADING PLAN**  
 RESIDENTIAL USE DEVELOPMENT  
 50 THE DRIVEWAY  
 OTTAWA, ONTARIO



DESIGNED BY: DF	DATE: NOV 29, 2022	CHECKED BY: NM
DRAWN BY: DF	PROJECT No:	APPROVED BY: NM
SCALE: 1:150		DRAWING No:
© COPYRIGHT 2023 Lithos Group Ltd.	<b>UD22-093</b>	<b>SG-01</b>

- GENERAL NOTES**
- COORDINATE AND SCHEDULE ALL WORK WITH OTHER TRADES AND CONTRACTORS.
  - OBTAIN ALL NECESSARY PERMITS AND APPROVALS FROM THE CITY OF OTTAWA BEFORE COMMENCING CONSTRUCTION, SUCH AS, BUT NOT LIMITED TO THE FOLLOWING: ROAD CUT PERMITS, SEWER PERMITS, APPROACH APPROVAL PERMITS, RELOCATION OF SERVICES, COMMITTEE OF ADJUSTMENT, ENCROACHMENT AGREEMENTS, WATER PERMIT, ETC
  - DRAWINGS TO BE READ IN CONJUNCTION WITH CONTRACT SPECIFICATIONS.
  - ALL DIMENSIONS SHALL BE CHECKED AND VERIFIED IN THE FIELD BY THE CONTRACTOR PRIOR TO THE START OF CONSTRUCTION. ANY DISCREPANCIES SHALL BE REPORTED IMMEDIATELY TO THE ENGINEER.
  - ALL DIMENSIONS ARE IN METERS UNLESS OTHERWISE SPECIFIED. ALL ELEVATIONS ARE GEODETIC.
  - ALL PIPE / CULVERT / SECTION SIZES REFER TO INSIDE DIMENSIONS.
  - ALL WORKS AND MATERIALS SHALL CONFORM TO THE LATEST REVISIONS OF STANDARDS AND SPECIFICATIONS OF THE CITY OF OTTAWA, AND ONTARIO PROVINCIAL STANDARD DRAWINGS (OPSD) AND SPECIFICATIONS (OPSS), AS AMENDED BY THE CITY OF OTTAWA. ONTARIO PROVINCIAL STANDARDS AND SPECIFICATIONS WILL APPLY WHERE NO CITY STANDARDS ARE AVAILABLE.
  - THE CONTRACTOR SHALL DETERMINE THE EXACT LOCATION, SIZE, MATERIAL AND ELEVATION OF ALL EXISTING UTILITIES WITHIN THE SITE AND ADJACENT WORK AREAS PRIOR TO COMMENCING CONSTRUCTION. THE CONTRACTOR SHALL BE RESPONSIBLE FOR PROTECTING ALL EXISTING UTILITIES TO THE SATISFACTION OF THE AUTHORITY HAVING JURISDICTION. THE CONTRACTOR SHALL BE RESPONSIBLE FOR REPAIR OR REPLACEMENT OF ANY SERVICES OR UTILITIES DISTURBED DURING CONSTRUCTION, TO THE SATISFACTION OF THE AUTHORITY HAVING JURISDICTION.
  - ANY AREAS BEYOND THE LIMIT OF THE SITE DISTURBED DURING CONSTRUCTION SHALL BE RESTORED TO ORIGINAL CONDITION OR BETTER TO THE SATISFACTION OF THE AUTHORITY HAVING JURISDICTION AT THE CONTRACTOR'S EXPENSE.
  - ALL DISTURBED AREAS ON SITE AND OFF-SITE, INCLUDING TRENCHES AND SURFACES ON PUBLIC ROAD ALLOWANCES SHALL BE RESTORED TO EXISTING CONDITIONS OR BETTER TO THE SATISFACTION OF THE CITY OF OTTAWA AND ENGINEER.

- ALL EXCESS EXCAVATED MATERIAL, ORGANIC MATERIAL AND DEBRIS SHALL BE REMOVED FROM SITE UNLESS OTHERWISE INSTRUCTED BY ENGINEER. ANY CONTAMINATED MATERIAL WILL BE EXCAVATED AND REMOVED FROM SITE. ALL CONTAMINATED MATERIAL SHALL BE DISPOSED OF AT A LICENSED LANDFILL FACILITY.
- RELOCATION OF EXISTING SERVICES AND / OR UTILITIES SHALL BE AS SHOWN ON THE DRAWINGS OR AS DIRECTED BY THE ENGINEER AT THE EXPENSE OF THE DEVELOPER.
- ALL WORK SHALL BE COMPLETED IN ACCORDANCE WITH THE "OCCUPATIONAL HEALTH AND SAFETY ACT AND REGULATIONS FOR CONSTRUCTION PROJECTS". THE GENERAL CONTRACTOR SHALL BE DEEMED TO BE THE CONSTRUCTOR AS DEFINED IN THE ACT.
- ALL TEMPORARY TRAFFIC CONTROL AND CONSTRUCTION SIGNAGE MUST CONFORM TO THE M.T.O. MANUAL OF UNIFORM TRAFFIC CONTROL DEVICES (LATEST AMENDMENT).
- SHOULD DEEPLY BURIED ARCHAEOLOGICAL REMAINS BE FOUND ON THE PROPERTY DURING CONSTRUCTION ACTIVITIES, THE HERITAGE OPERATIONS UNIT OF THE ONTARIO MINISTRY OF CULTURE MUST BE NOTED IMMEDIATELY.
- STREET LIGHTING SHALL BE TO THE CITY OF OTTAWA STANDARDS.
- THE SUPPORT OF ALL UTILITIES SHALL BE IN ACCORDANCE WITH THE REQUIREMENTS OF THE AUTHORITY HAVING JURISDICTION.
- THERE WILL BE NO SUBSTITUTION OF MATERIALS UNLESS PRIOR WRITTEN APPROVAL BY THE CITY OF OTTAWA HAS BEEN OBTAINED.
- ALL NECESSARY CLEARING AND GRUBBING SHALL BE COMPLETED BY THE CONTRACTOR. REVIEW WITH CONTRACT ADMINISTRATOR AND THE CITY OF OTTAWA PRIOR TO ANY TREE CUTTING.

- ROADWORKS - GRADING**
- ALL TOPSOIL AND ORGANIC MATERIAL SHALL BE ENTIRELY STRIPPED WITHIN THE ROAD ALLOWANCE & BENEATH THE PROPOSED PAVED AREAS PRIOR TO THE COMMENCEMENT OF CONSTRUCTION AS DIRECTED BY THE SITE ENGINEER OR GEOTECHNICAL ENGINEER.
  - EXPOSED SUBGRADES IN PROPOSED PAVED AREAS SHOULD BE PROOF ROLLED WITH A LARGE STEEL DRUM ROLLER AND INSPECTED BY THE GEOTECHNICAL ENGINEER PRIOR TO THE PLACEMENT OF GRANULARS.
  - ANY SOFT AREAS EVIDENT FROM THE PROOF ROLLING SHOULD BE SUB-EXCAVATED AND REPLACED WITH SUITABLE MATERIAL THAT IS FROST COMPATIBLE WITH THE EXISTING SOILS AS RECOMMENDED BY THE GEOTECHNICAL ENGINEER.
  - GRANULAR "A" SHALL BE PLACED TO A MINIMUM THICKNESS OF 300MM AROUND ALL STRUCTURES WITHIN PAVEMENT AREA.
  - GRANULAR BASE SHOULD BE COMPACTED TO AT LEAST 100% OF THE STANDARD PROCTOR MAXIMUM DRY DENSITY VALUE. ANY ADDITIONAL GRANULAR FILL USED BELOW THE PROPOSED PAVEMENT SHOULD BE COMPACTED TO AT LEAST 95% OF THE STANDARD PROCTOR MAXIMUM DRY DENSITY VALUE.
  - ROAD SUBDRAINS SHALL BE IN ACCORDANCE WITH CITY OF OTTAWA STD. R1.
  - CONCRETE CURB SHALL BE IN ACCORDANCE WITH CITY OF OTTAWA STD. SC1.1 (BARRIER CURB) AND SC1.3 (MOUNTABLE CURB). PROVISION SHALL BE MADE FOR CURB DEPRESSIONS AT SIDEWALKS AND DRIVEWAYS.
  - PEDESTRIAN CURB RAMP WITH BOULEVARD SHALL BE IN ACCORDANCE WITH CITY OF OTTAWA STD. SC7.
  - CONCRETE SIDEWALK SHALL BE IN ACCORDANCE WITH CITY OF OTTAWA STD. SC3 AND SC1.4.
  - PAVEMENT REINSTATEMENT FOR SERVICE & UTILITY CUTS SHALL BE IN ACCORDANCE WITH CITY OF OTTAWA STD. R10 AND OPSD 509.010, OPSS 310.
  - ASPHALT WEAR COURSE SHALL NOT BE PLACED UNTIL THE VIDEO INSPECTION OF SEWERS AND NECESSARY REPAIRS HAVE BEEN CARRIED OUT TO THE SATISFACTION OF THE ENGINEER.
  - REFER TO LANDSCAPE PLAN FOR PLANTING AND OTHER LANDSCAPE FEATURE DETAILS.

#187958



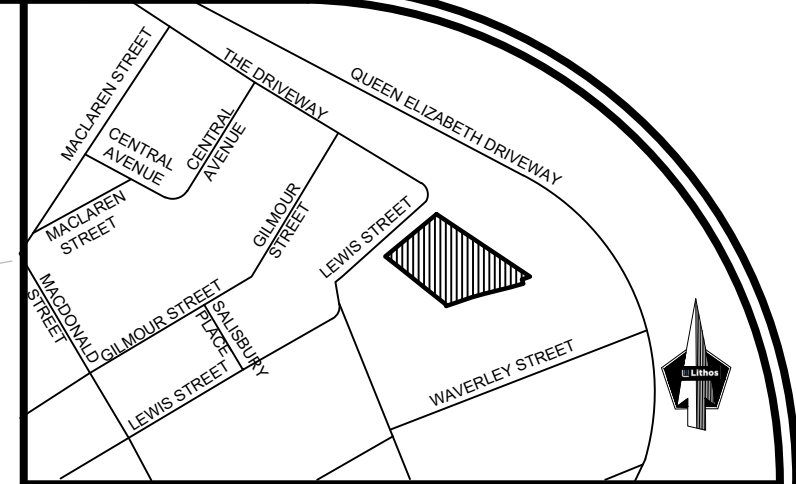
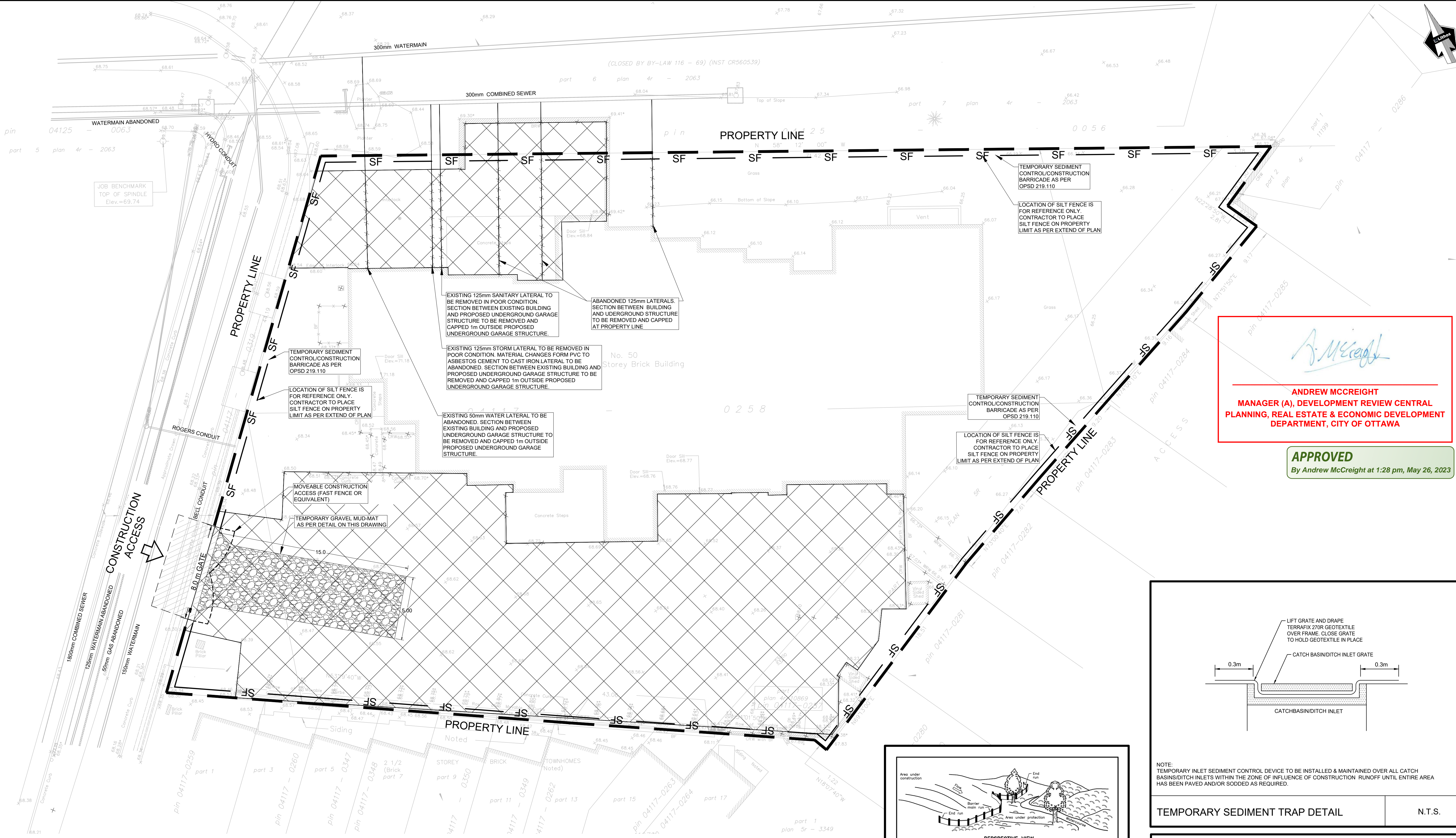

© 2022 GOOGLE, MAP DATA © 2022 TELE ATLAS  
**LOCATION PLAN**  
 NTS

**LEGEND**

PROPERTY LINE	---
TEMPORARY SEDIMENT CONTROL FENCE	SF
TEMPORARY GRAVEL MUD MAT	⊞
TEMPORARY CONSTRUCTION ACCESS	↔

**LIST OF DRAWINGS**

SG-01 (SITE GRADING PLAN)	
SS-01 (SITE SERVING PLAN)	
EC-01 (EROSION CONTROL PLAN)	
DD-01 (DETAIL DRAWINGS)	

**SITE PLAN INFORMATION**  
 HOBIN ARCHITECTURE INCORPORATED  
 63 PAMILLA STREET  
 OTTAWA, ON K1S 3K7  
 TEL: 613-238-7200  
 FAX: 613-235-2025  
 Email: mail@hobinarc.com

**SURVEY INFORMATION**  
 ANNIS, O'SULLIVAN, VOLLEBEK LTD.  
 14 CONCOURSE GATE, SUITE 500,  
 NEPEAN, ON K2E 7S6  
 TEL: (613) 727-0850  
 FAX: (613) 727-1079  
 EMAIL: Nepean@acvilt.com

**BENCHMARK**  
 ELEVATIONS SHOWN ARE GEODETIC AND ARE REFERRED TO THE CDVD28 GEODETIC DATUM DERIVED FROM VERTICAL CONTROL MONUMENT No. 3646 HAVING AN ELEVATION OF 69.851 METRES.

*Andrew McCreight*  
**ANDREW MCCREIGHT**  
 MANAGER (A), DEVELOPMENT REVIEW CENTRAL  
 PLANNING, REAL ESTATE & ECONOMIC DEVELOPMENT  
 DEPARTMENT, CITY OF OTTAWA

**APPROVED**  
 By Andrew McCreight at 1:28 pm, May 26, 2023

**EROSION AND SEDIMENT CONTROL**

- EROSION AND SEDIMENT CONTROL (ESC) MEASURES WILL BE IMPLEMENTED PRIOR TO, AND MAINTAINED DURING CONSTRUCTION PHASES, TO PREVENT ENTRY OF SEDIMENT INTO THE WATER. ALL DAMAGED EROSION AND SEDIMENT CONTROL MEASURES SHOULD BE REPAIRED OR REPLACED WITHIN 48 HOURS OF INSPECTION OR BOTH.
  - ALL DISTURBED AREAS WILL BE MINIMIZED TO THE EXTENT POSSIBLE, AND TEMPORARILY OR PERMANENTLY STABILIZED OR RESTORED AS THE WORK PROGRESSES.
  - THE EROSION AND SEDIMENT CONTROL STRATEGIES OUTLINED ON THE PLANS ARE NOT STATIC AND MAY NEED TO BE UPGRADED / AMENDED AS SITE CONDITIONS CHANGE TO MINIMIZE SEDIMENT LOADED RUNOFF FROM LEAVING THE WORK AREA. IF THE PRESCRIBED MEASURES ON THE PLANS ARE NOT EFFECTIVE IN PREVENTING THE RELEASE OF A DELETERIOUS SUBSTANCE, THEN ALTERNATIVE MEASURES MUST BE IMPLEMENTED IMMEDIATELY TO MINIMIZE POTENTIAL ECOLOGICAL IMPACTS AND A TORONTO REGION CONSERVATION AUTHORITY ENFORCEMENT OFFICE SHOULD BE IMMEDIATELY CONTACTED ADDITIONAL ESC MEASURES TO BE KEPT ON SITE AND USED AS NECESSARY.
  - ALL ACTIVITIES, INCLUDING MAINTENANCE PROCEDURES, WILL BE CONTROLLED TO PREVENT THE ENTRY OF PETROLEUM PRODUCTS, DEBRIS, RUBBLE, CONCRETE OR OTHER DELETERIOUS SUBSTANCES INTO THE WATER. VEHICULAR REFUELING AND MAINTENANCE AND REFUELING WILL BE CONDUCTED A MINIMUM OF 30M FROM THE WATER.
  - ALL GRADES WITHIN THE REGULATORY FLOOD PLAN WILL BE MAINTAINED OR MATCHED.
- SEDIMENT BARRIERS, CHECK DAMS, AND TEMPORARY CONSTRUCTION ACCESS TO BE INSTALLED PRIOR TO THE BEGINNING OF CONSTRUCTION.
  - ALL SEDIMENT CONTROL DEVICES TO BE ROUTINELY INSPECTED AND MAINTAINED IN PROPER WORKING ORDER UNTIL AREA IS STABILIZED.
  - IF NECESSARY, TRUCKS WILL BE WASHED DOWN BEFORE LEAVING THE SITE.
  - THE SITE WILL BE WET DOWN IF NECESSARY TO CONTROL DUST.
  - ALL CONSTRUCTION EQUIPMENT MUST BE PARKED ON-SITE.
  - ALL CONSTRUCTION ACTIVITY WILL COMPLY WITH CITY OF TORONTO NOISE BYLAW.
  - SEDIMENT CONTROL FENCE TO BE AS PER CITY OF TORONTO STANDARD T-219.130-1.
  - ALL CONSTRUCTION VEHICLES TO ENTER AND EXIT SITE FROM TEMPORARY CONSTRUCTION ACCESS.
  - STREET SWEEPING, CATCH BASIN CLEANING AND DUST CONTROL ARE THE RESPONSIBILITY OF THE DEVELOPER AND MUST BE KEPT UNDER CONTROL ON ALL ROADWAYS TO THE SATISFACTION OF THE CITY.

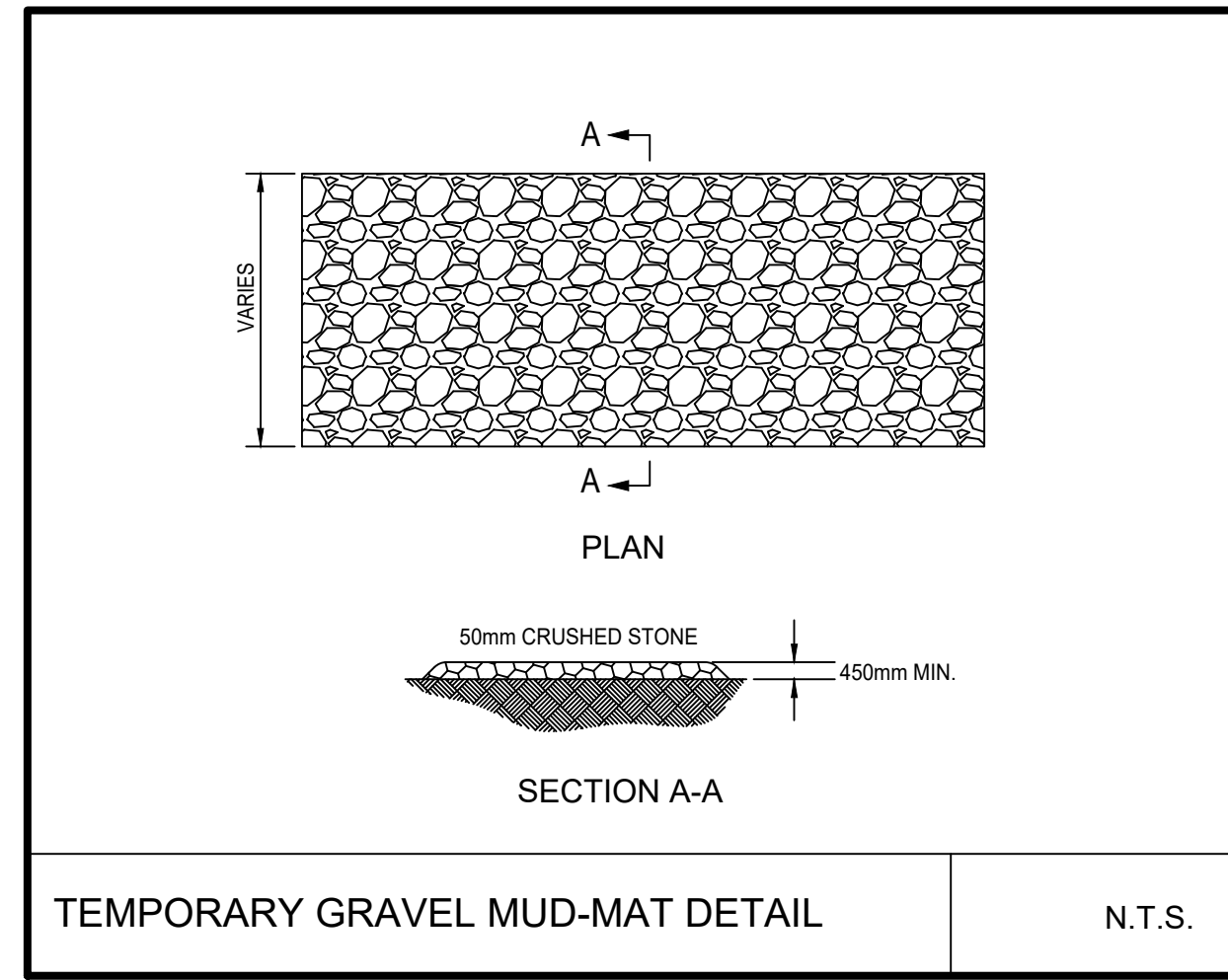
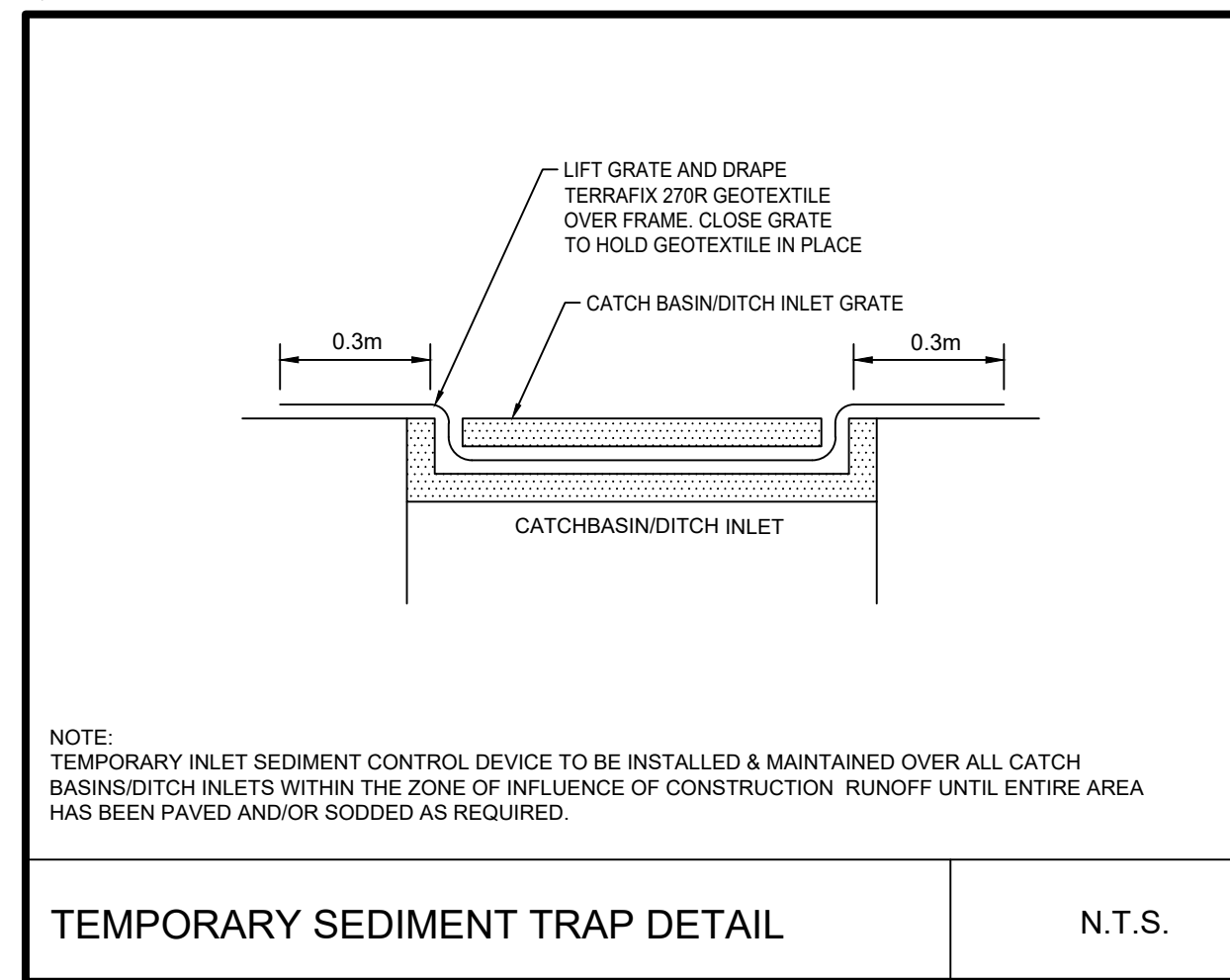
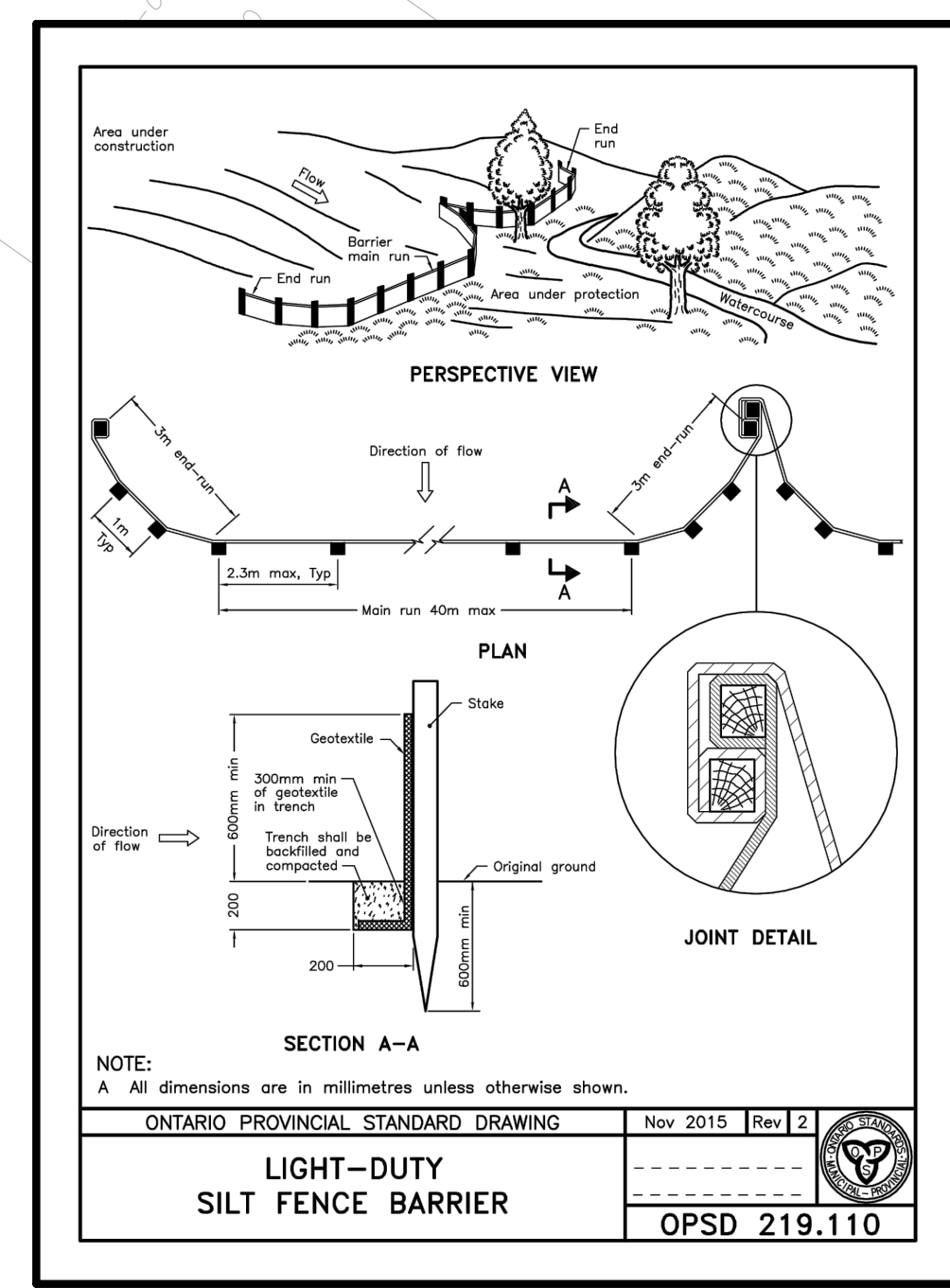

NO	REVISION	DATE	BY
2	ISSUED FOR SITE PLAN APPLICATION	MAR 27, 2023	NM
1	ISSUED FOR SITE PLAN APPLICATION	JAN 16, 2023	NM



CITY OF OTTAWA

**EROSION CONTROL & REMOVALS - REINSTATEMENT PLAN**

RESIDENTIAL USE DEVELOPMENT  
 50 THE DRIVEWAY  
 OTTAWA, ONTARIO



150 Bermondsey Road, Toronto, Ontario M4A 1Y1

DESIGNED BY: DF	DATE: NOV 29, 2022	CHECKED BY: NM
DRAWN BY: DF	PROJECT No:	APPROVED BY: NM
SCALE: 1:150		DRAWING No:
© COPYRIGHT 2022 Lithos Group Ltd.	UD22-093	EC-01

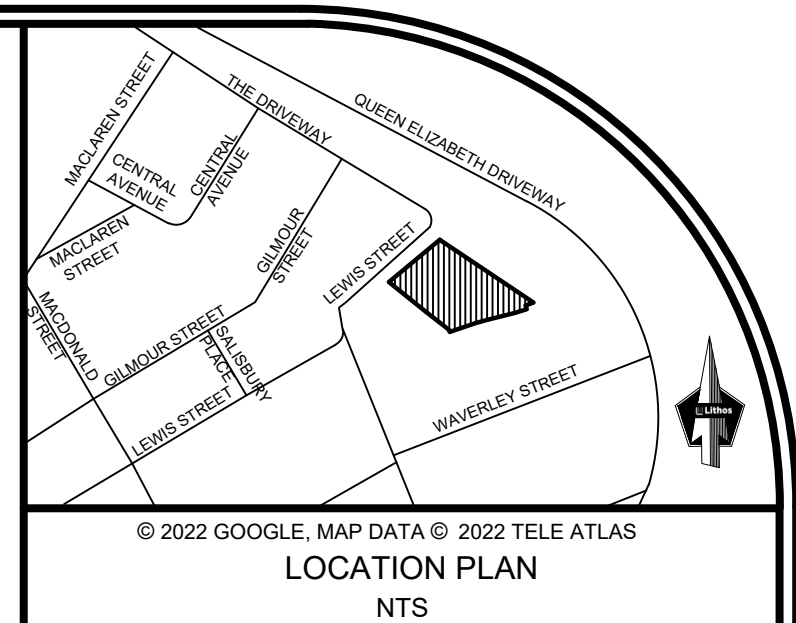
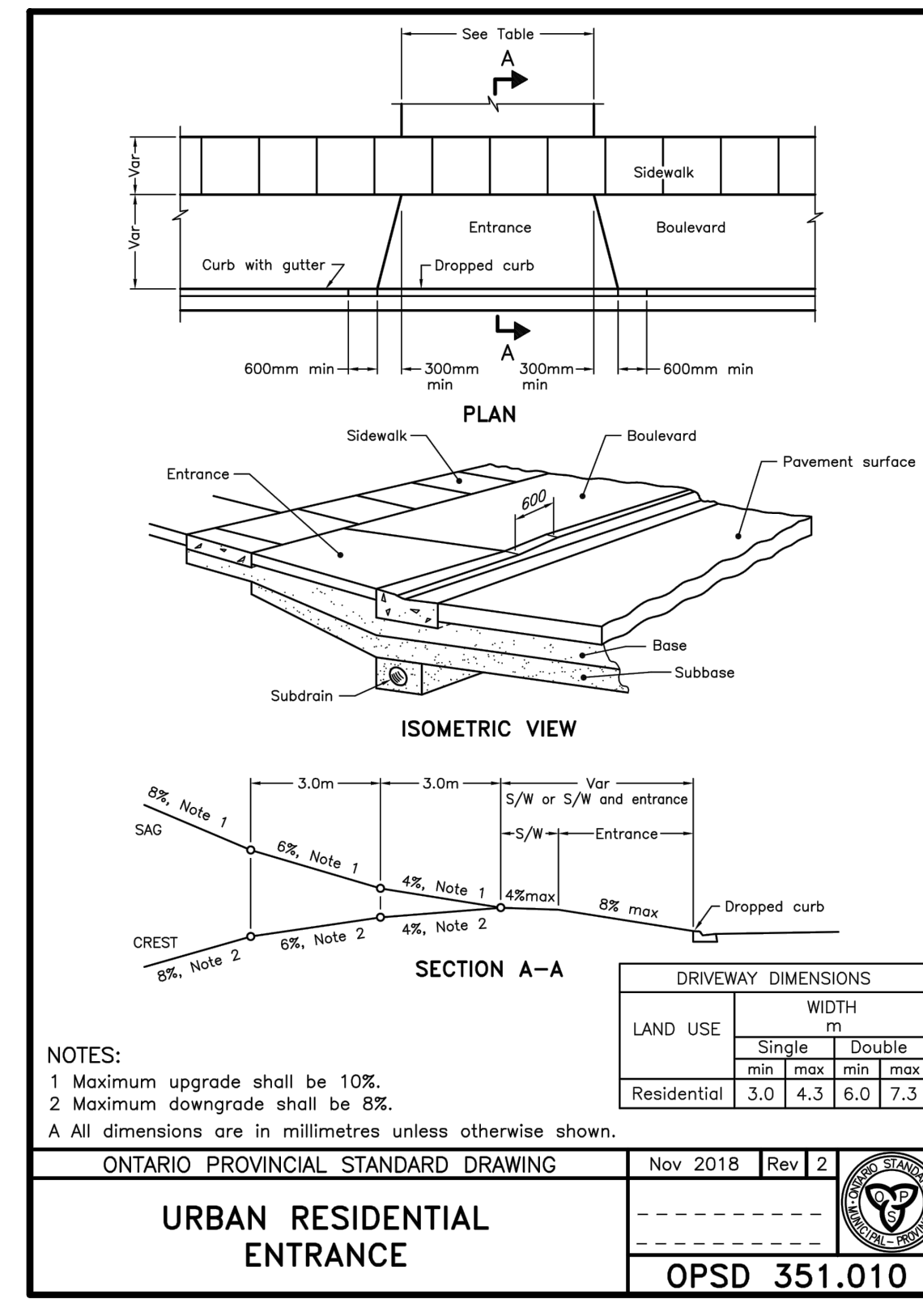
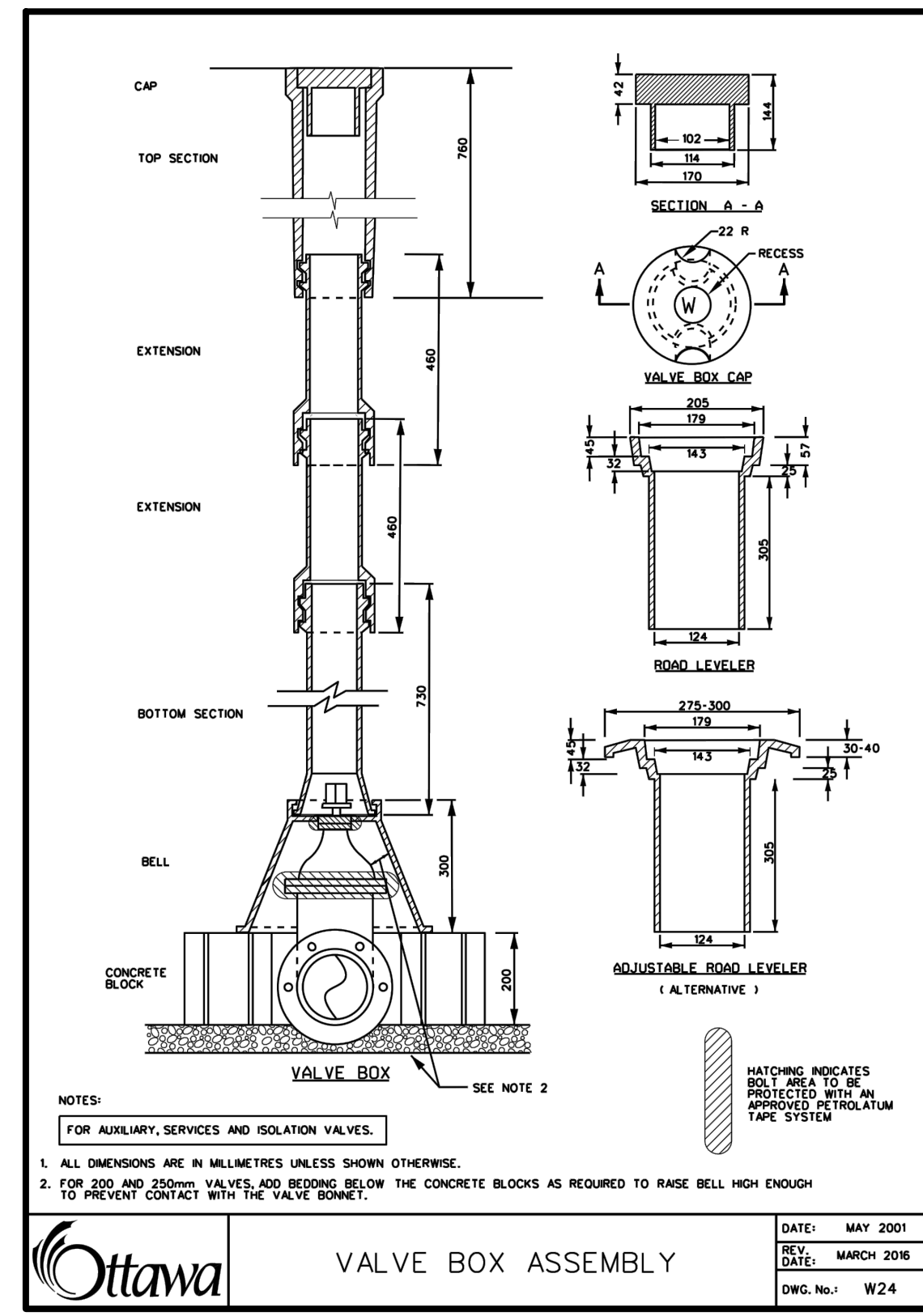
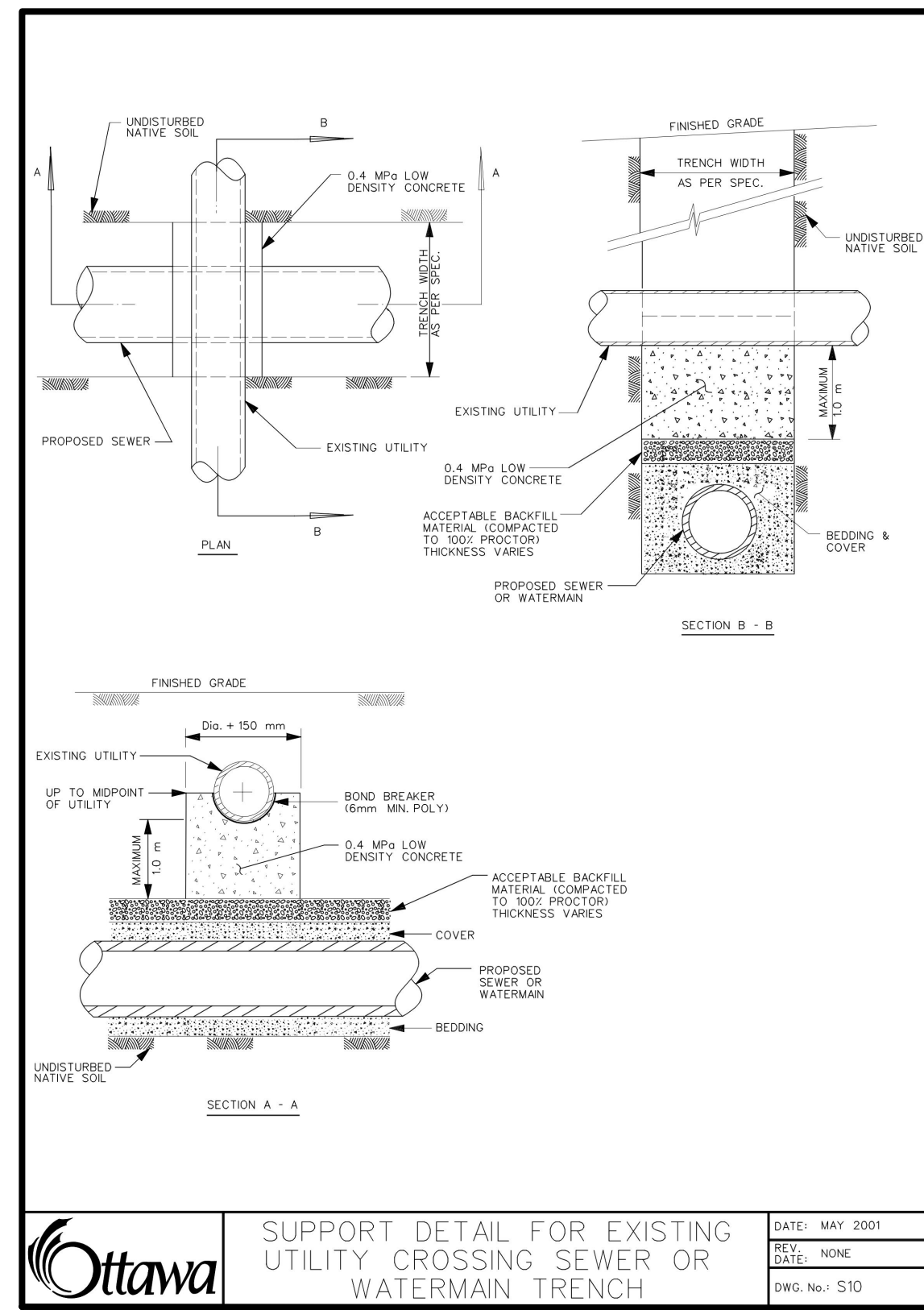
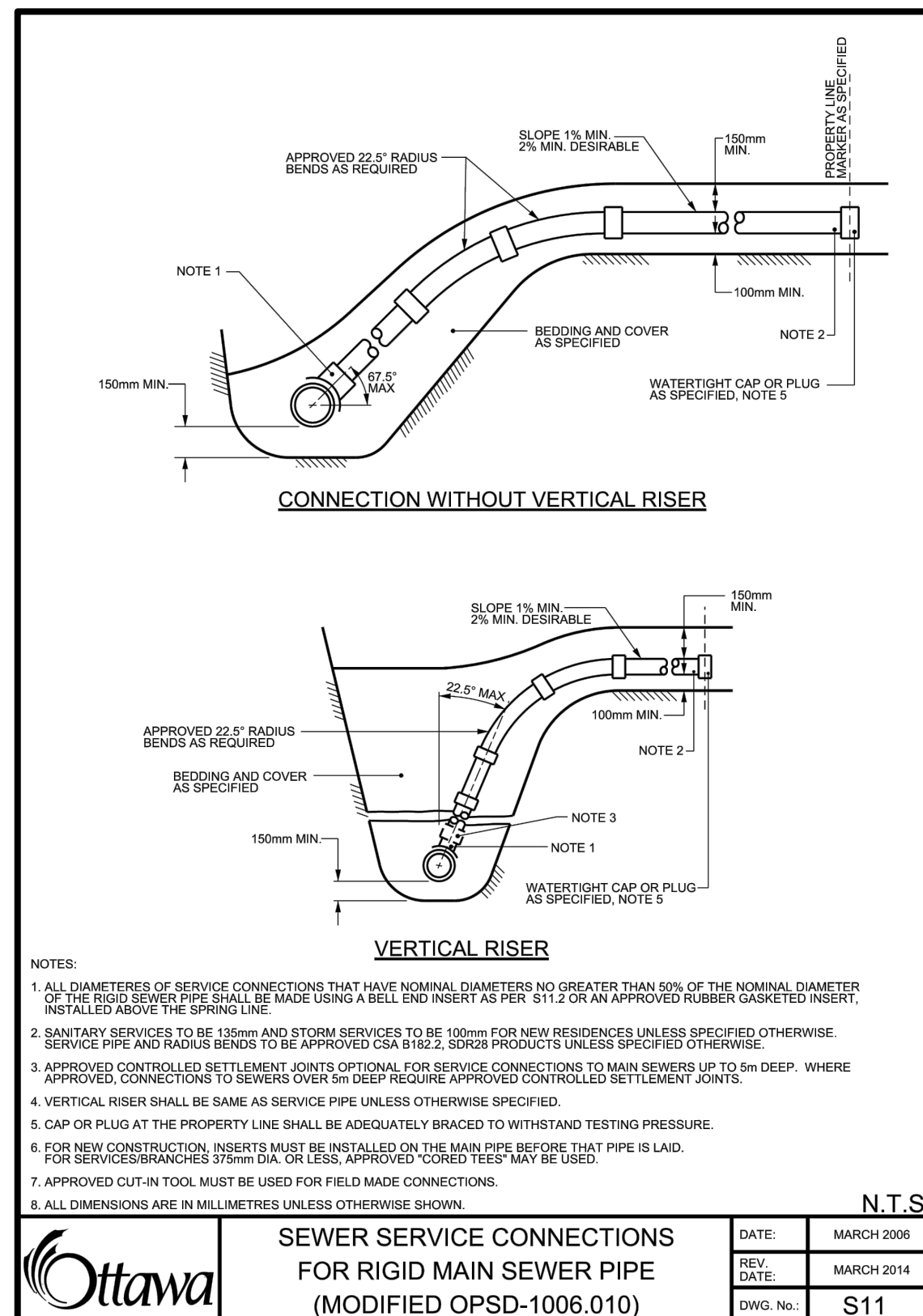

**LIST OF DRAWINGS**

SG-01 (SITE GRADING PLAN)	
SS-01 (SITE SERVICING PLAN)	
EC-01 (EROSION CONTROL PLAN)	
DD-01 (DETAIL DRAWINGS)	

**SITE PLAN INFORMATION**

HOBIN ARCHITECTURE INCORPORATED  
63 PAMILLA STREET  
OTTAWA, ON K1S 3K7  
TEL: 613-238-7200  
FAX: 613-235-2005  
Email: mail@hobinarc.com

**SURVEY INFORMATION**

ANNIS, O'SULLIVAN, VOLLEBECK LTD.  
14 CONCOURSE GATE, SUITE 500,  
NEPEAN, ON K2E 7S6  
TEL: (613) 727-0850  
FAX: (613) 727-1079  
EMAIL: Nepean@avild.com

**BENCHMARK**

ELEVATIONS SHOWN ARE GEODETIC AND ARE REFERRED TO THE COVD28 GEODETIC DATUM DERIVED FROM VERTICAL CONTROL MONUMENT NO. 3646 HAVING AN ELEVATION OF 69.851 METRES.

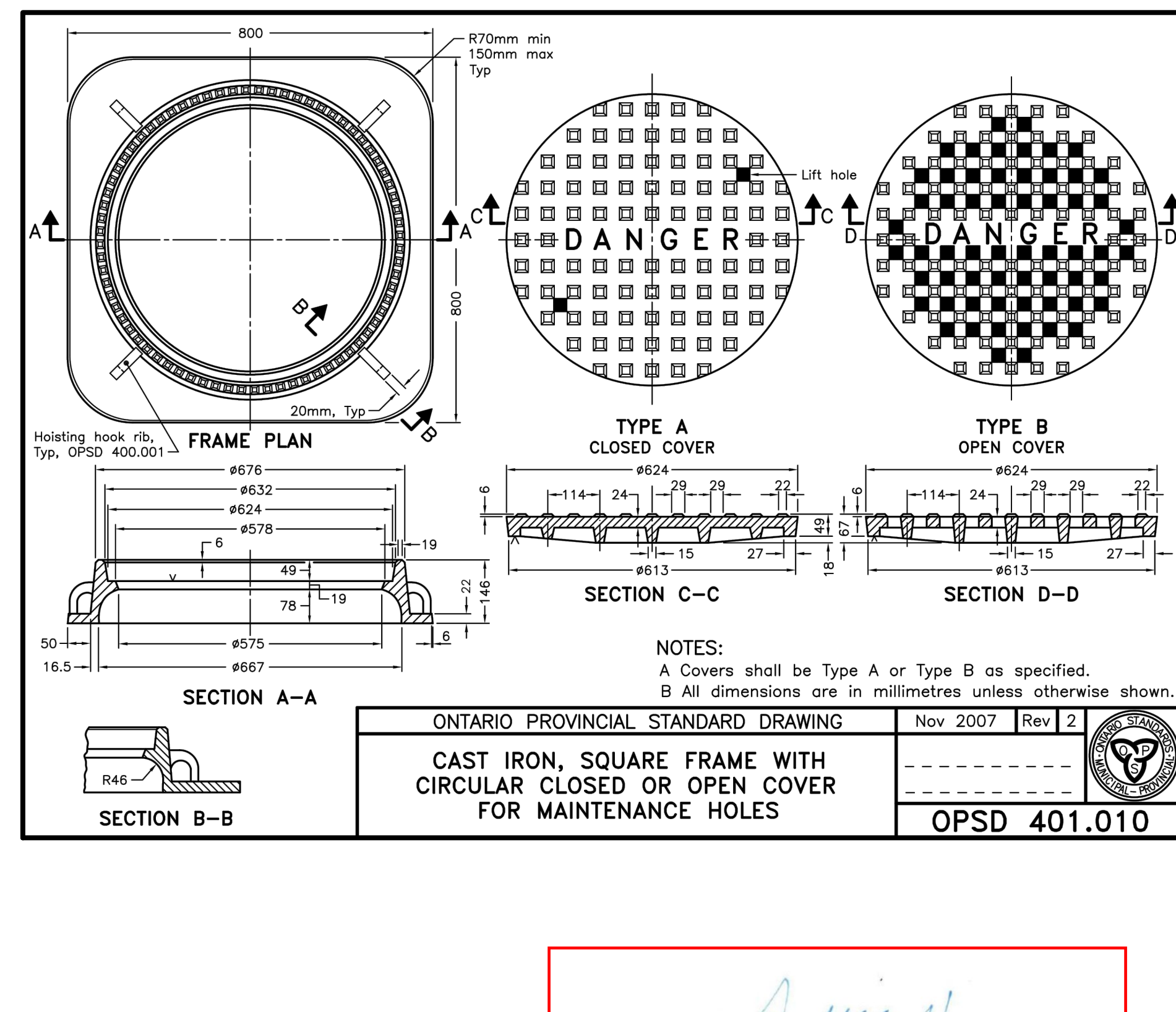
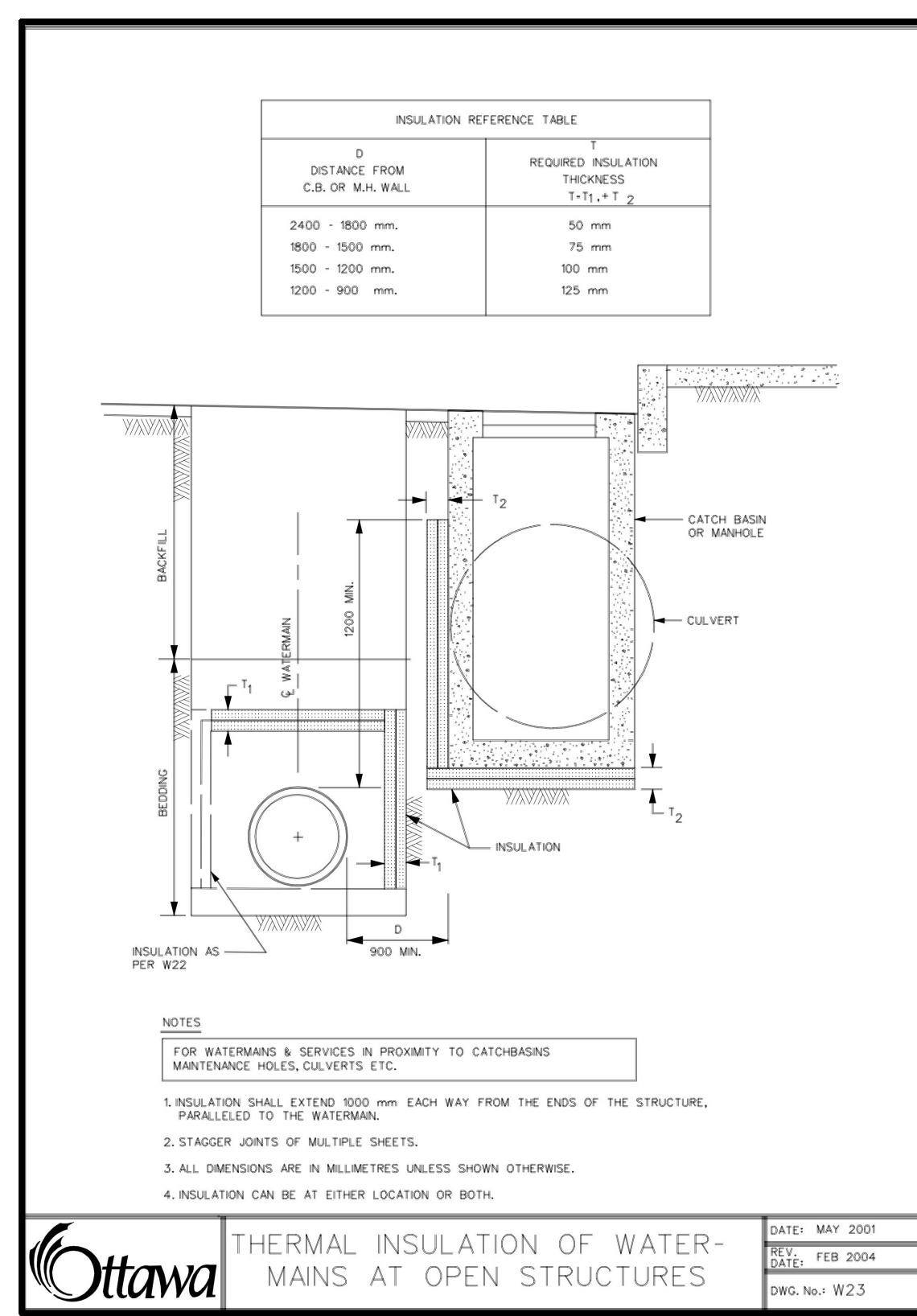
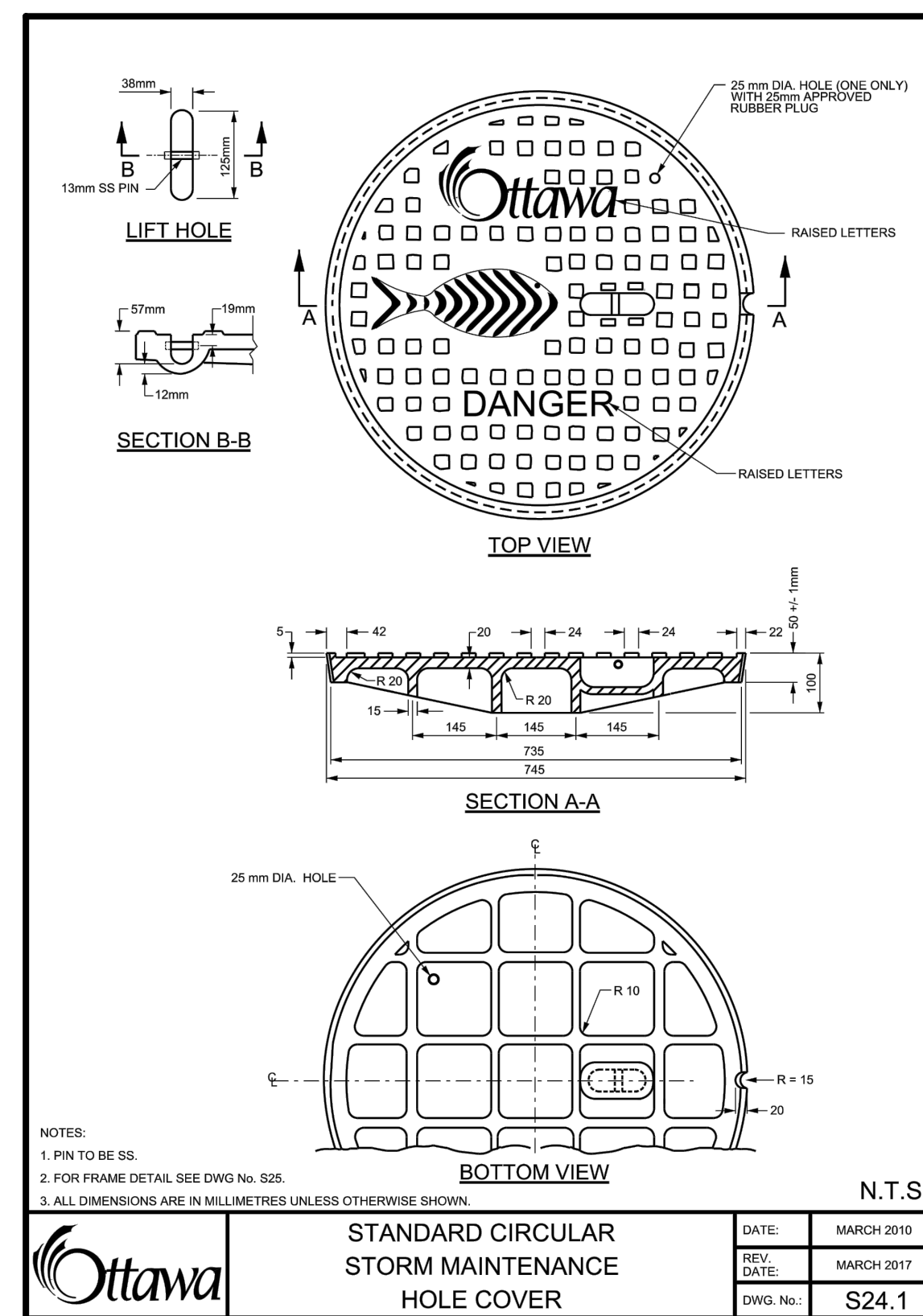
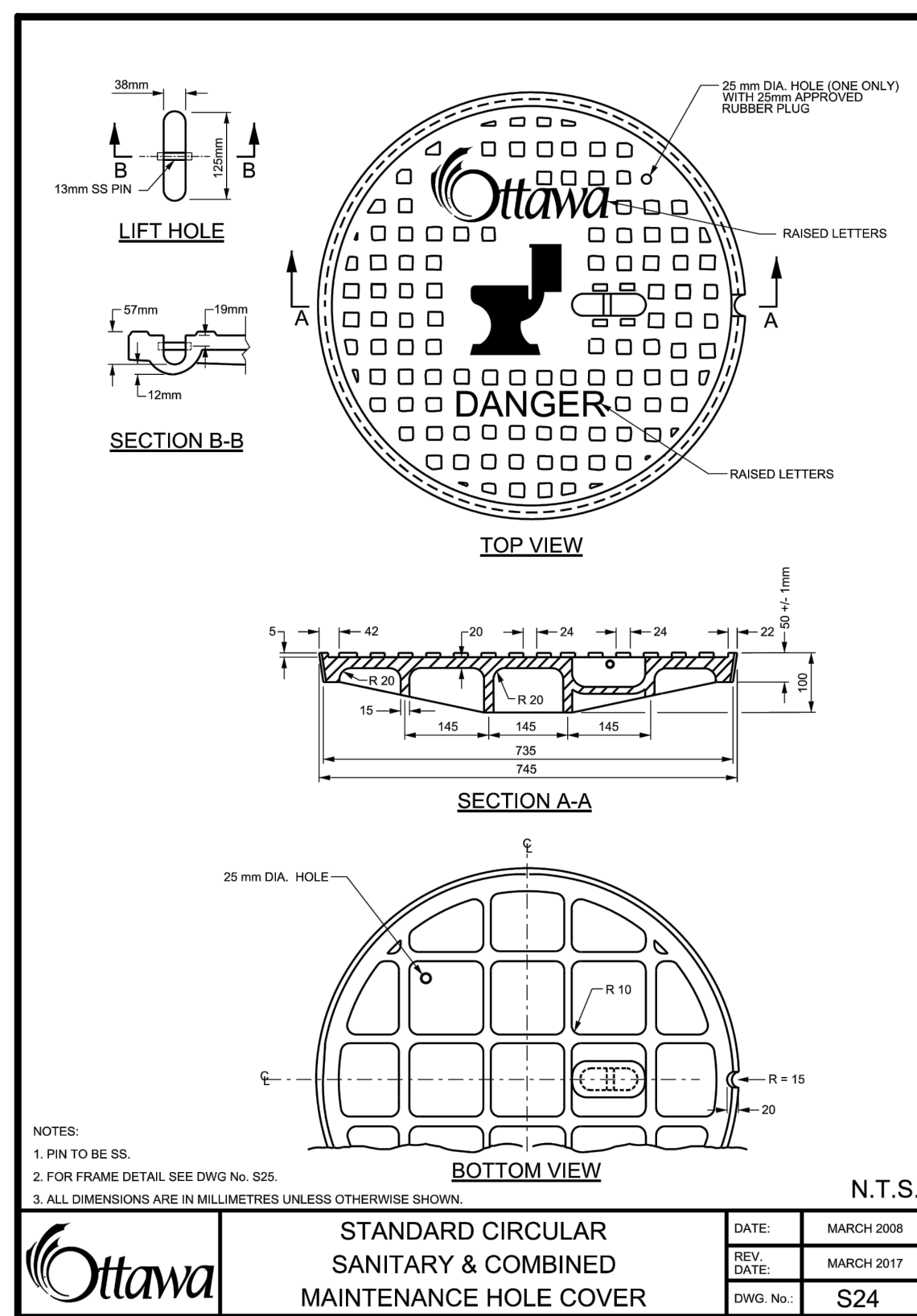

**ISSUED FOR SITE PLAN APPLICATION**

NO	REVISION	DATE	BY
1.	ISSUED FOR SITE PLAN APPLICATION	MAR 27, 2023	NM
2.	ISSUED FOR SITE PLAN APPLICATION	JAN 16, 2023	NM

**PROFESSIONAL ENGINEER**  
M. MOUTZOURIS  
100176986  
2023/03/27  
PROVINCE OF ONTARIO

**GENERAL NOTES**

- ALL SEWERS CONSTRUCTED WITH GRADES 0.5% OR LESS, SHALL BE INSTALLED WITH PIPE LASER AND CHECKED WITH LEVEL INSTRUMENTS PRIOR TO BACKFILLING.
- THE CONTRACTOR SHALL BE RESPONSIBLE FOR ADDITIONAL BEDDING OR ADDITIONAL STRENGTH PIPE IF THE MAXIMUM TRENCH WIDTH, AS SPECIFIED BY OPSD, IS EXCEEDED.
- CONTRACTOR SHALL PERFORM LEAKAGE TESTING, IN THE PRESENCE OF THE CONSULTANT, FOR SANITARY SEWERS IN ACCORDANCE WITH OPSD 410 AND OPSD 407. CONTRACTOR SHALL PERFORM VIDEO INSPECTION OF ALL STORM AND SANITARY SEWERS. A COPY OF THE VIDEO AND INSPECTION REPORT SHALL BE SUBMITTED TO THE ENGINEER FOR REVIEW.
- CLAY SEALS TO BE INSTALLED AS PER CITY STANDARD DRAWING NO. S8. THE SEALS SHOULD BE AT LEAST 1.5M LONG (IN THE TRENCH DIRECTION) AND SHOULD EXTEND FROM TRENCH WALL TO TRENCH WALL. GENERALLY, THE SEALS SHOULD EXTEND FROM BELOW THE FROST LINE, 1.5 TO 2.0 M BELOW FINISH GRADE, AND FULLY PENETRATE THE BEDDING, SUBBEDDING AND PIPE COVER MATERIAL. THE BARRIERS SHOULD CONSIST OF RELATIVELY DRY AND COMPACTABLE BROWN SILTY CLAY PLACED IN MAXIMUM 225MM THICK LOOSE LAYERS COMPACTED TO A MINIMUM OF 95% OF THE MATERIAL'S SPOND. THE CLAY SEALS SHOULD BE PLACED AT THE SITE BOUNDARIES AND AT STRATEGIC LOCATIONS AT NO MORE THAN 100M INTERVALS IN THE SERVICE TRENCHES.
- ALL INSPECTIONS SHALL BE PERFORMED IN ACCORDANCE WITH APPLICABLE FEDERAL AND PROVINCIAL PRIVACY LEGISLATION INCLUDING THE CANADIAN PERSONAL INFORMATION PROTECTION AND ELECTRONIC DOCUMENTS ACT (PIPEDA). DOCUMENTATION CONFIRMING COMPLIANCE WITH THIS LEGISLATION SHALL BE MADE AVAILABLE TO THE OWNER AND SUBMITTED WITH THE PRE-CONSTRUCTION INSPECTION REPORT.

**STORM SEWERS**

- ALL PVC STORM SEWERS ARE TO BE SDR 35 APPROVED PER C.S.A. B182.2 OR LATEST AMENDMENT, UNLESS OTHERWISE SPECIFIED.
- ALL STORM SEWER TRENCH AND BEDDING SHALL BE IN ACCORDANCE WITH CITY OF OTTAWA STD. S6 AND S7 CLASS "B" UNLESS OTHERWISE SPECIFIED. BEDDING AND COVER MATERIAL SHALL BE SPECIFIED BY PROJECT GEOTECHNICAL ENGINEER.
- ALL STORM LATERALS SHALL BE PVC SDR 28, WHITE IN COLOR AND MARKED WITH A 50MMX100MM WOODEN MARKER EXTENDING FROM THE INVERT TO 1.0 M ABOVE GRADE PAINTED GREEN. HOUSE CONNECTIONS SHALL BE 2.0M MIN. BELOW FINISHED GRADE AT STREET LINE WHERE POSSIBLE. SINGLE CONNECTIONS SHALL BE 100MM DIA.

**GENERAL NOTES**

- ALL STORM SERVICES TO BE EQUIPPED WITH APPROVED BACKWATER VALVES.
- STORM MANHOLE FRAME AND COVERS SHALL BE AS PER CITY OF OTTAWA STD. S24, S24.1, AND S25.
- SAFETY PLATFORMS SHALL BE IN ACCORDANCE WITH OPSD 404.02.
- DROP STRUCTURES SHALL BE IN ACCORDANCE WITH CITY OF OTTAWA SPECIFICATIONS AND OPSD 1003.031.
- STORM SEWER MANHOLES SERVING LOCAL SEWERS LESS THAN 900MM SHALL BE CONSTRUCTED WITH A 300MM SLUMP.
- THE STORM SEWER CLASSES HAVE BEEN DESIGNED BASED ON BEDDING CONDITIONS SPECIFIED ABOVE. WHERE THE SPECIFIED TRENCH WIDTH IS EXCEEDED, THE CONTRACTOR SHALL BE REQUIRED TO PROVIDE ADDITIONAL BEDDING, A DIFFERENT TYPE OF BEDDING OR A HIGHER PIPE STRENGTH AT HIS OWN EXPENSE AND SHALL ALSO BE RESPONSIBLE FOR EXTRA TEMPORARY AND / OR PERMANENT REPAIRS MADE NECESSARY BY THE WIDENED TRENCH.

**SANITARY SEWERS**

- ALL SANITARY SEWERS SHALL BE PVC SDR 35, IPEX "RING-TITE" (OR EQUIVALENT), AS PER CSA STANDARD B182.2 OR LATEST AMENDMENT, UNLESS OTHERWISE NOTED.
- SANITARY SEWER TRENCH AND BEDDING SHALL BE AS PER CITY OF OTTAWA STD. S6 AND S7 CLASS "B" BEDDING UNLESS OTHERWISE NOTED.
- ALL SANITARY LATERALS ARE TO BE PVC SDR 28, IPEX "RING-TITE" (OR EQUIVALENT), ANY COLOR EXCEPT WHITE AND MARKED WITH A 50MMX100MM WOODEN MARKER EXTENDING FROM THE INVERT TO 1.0 M ABOVE GRADE PAINTED RED. HOUSE CONNECTIONS SHALL BE 2.75M MIN. BELOW FINISHED GRADE AT STREET LINE WHERE POSSIBLE. SINGLE CONNECTIONS SHALL BE 135MM DIA.
- ALL SANITARY SERVICES TO BE EQUIPPED WITH APPROVED BACKWATER VALVES.
- SANITARY MANHOLE FRAME AND COVERS SHALL BE AS PER CITY OF OTTAWA STD. S24 AND S25.
- SAFETY PLATFORMS SHALL BE IN ACCORDANCE WITH OPSD 404.02.
- DROP STRUCTURES SHALL BE IN ACCORDANCE WITH CITY OF OTTAWA SPECIFICATIONS AND OPSD 1003.031.
- SANITARY SEWER MANHOLES SHALL BE BENCHES AS PER OPSD 701.021.
- SANITARY PRE-CAST MANHOLE SHALL BE CONSTRUCTED WITH A HIGHER PERCENTAGE OF SILICA FUME IN THE CONCRETE TO MAKE IT MORE DENSE AND LESS SUSCEPTIBLE TO CORROSION OR PINHOLE LEAKS.
- FOR SANITARY MANHOLES, DEPENDING ON THE ELEVATION OF THE GROUNDWATER TABLE, AND BASED ON THE RECOMMENDATION OF THE PROJECT GEOTECHNICAL CONSULTANT, CRETEX SEALS, OR A SIMILAR PRODUCT, SHALL BE INSTALLED

**GENERAL NOTES**

- INSULATION SHALL EXTEND 1000 mm EACH WAY FROM THE ENDS OF THE STRUCTURE, PARALLEL TO THE WATERMAIN.
- STAGGER JOINTS OF MULTIPLE SHEETS.
- ALL DIMENSIONS ARE IN MILLIMETRES UNLESS SHOWN OTHERWISE.
- INSULATION CAN BE AT EITHER LOCATION OR BOTH.

**WATER SUPPLY**

- ALL PVC WATERMANS SHALL BE EQUAL TO AWWA C-900 CLASS 150, SDR 18, OR APPROVED EQUAL.
- WATERMAIN TRENCH AND BEDDING SHALL BE IN ACCORDANCE WITH CITY OF OTTAWA STANDARD W17, UNLESS OTHERWISE SPECIFIED. BEDDING AND COVER MATERIAL SHALL BE SPECIFIED BY PROJECT GEOTECHNICAL ENGINEER.
- ALL PVC WATERMANS SHALL BE INSTALLED WITH A 10 GAUGE STRANDER COPPER TWJ OR RWJ TRACER WIRE IN ACCORDANCE WITH CITY OF OTTAWA STD. W36.
- WATER SERVICES ARE TO BE TYPE K SOFT COPPER AS PER CITY OF OTTAWA STD. W26 UNLESS OTHERWISE SPECIFIED. SINGLE SERVICES SHALL BE 20MM DIA. 50MM DIA COPPER SHALL BE USED FOR PARK SERVICES. WATER SERVICES SHALL BE MARKED WITH A "50MMX100MM", EXTENDING FROM THE INVERT TO 1.0M ABOVE GRADE PAINTED BLUE. STAND POSTS / SHUT-OFFS SHALL BE INSTALLED AT PROPERTY LINE.
- CATHODIC PROTECTION IS REQUIRED ON ALL METALLIC FITTINGS AS PER CITY OF OTTAWA STD. W40 AND W42.
- CONTRACTOR TO SUPPLY HYDRANT EXTENSION TO ADJUST THE LENGTH OF HYDRANT BARREL.
- FIRE HYDRANTS SHALL BE INSTALLED AS PER CITY OF OTTAWA STD. W19, AND LOCATED AS PER CITY STD. W18.
- VALVE IN BOXES SHALL BE INSTALLED AS PER CITY OF OTTAWA STD. W24.
- THRUST BLOCKING OF WATERMAIN TO BE INSTALLED AS PER CITY OF OTTAWA STD. W25.3 AND W25.4.
- THE CONTRACTOR SHALL PROVIDE ALL TEMPORARY CAPS, PLUGS AND BLOW-OFFS AND NOZZLES REQUIRED FOR TESTING AND DISINFECTING OF THE WATERMAIN.
- WHERE SEPARATION BETWEEN SERVICES AND MANHOLES IS LESS THAN 1.2M, WATER SERVICES ARE TO BE INSULATED AS PER CITY OF OTTAWA STD. W23.
- AS PER CITY GUIDELINE, THE MINIMUM VERTICAL CLEARANCE BETWEEN WATERMAIN AND SEWER / UTILITY IS 0.25M FOR CROSSING OVER THE SEWER, AS PER CITY STD W25.2. FOR CROSSING UNDER SEWER, THE MINIMUM VERTICAL CLEARANCE IS 0.50M AS PER CITY STD. W25.
- FOR CROSSING UNDER SEWER, ADEQUATE STRUCTURAL SUPPORT FOR THE SEWERS IS REQUIRED TO PREVENT EXCESSIVE DEFLECTION OF JOINTS AND SETTLING. THE LENGTH OF WATER PIPE SHALL BE CENTERED AT THE POINT OF CROSSING SO THAT THE JOINTS WILL BE EQUIDISTANT AND AS FAR AS POSSIBLE FROM THE SEWER.
- ALL WATER SERVICES CROSSING SEWERS ARE TO BE INSTALLED AS PER CITY OF OTTAWA STD. W38.

*Andrew McCreight*

**ANDREW MCCREIGHT  
MANAGER (A), DEVELOPMENT REVIEW CENTRAL  
PLANNING, REAL ESTATE & ECONOMIC DEVELOPMENT  
DEPARTMENT, CITY OF OTTAWA**

**APPROVED**  
By Andrew McCreight at 1:28 pm, May 26, 2023

**CITY OF OTTAWA**

**DETAILS DRAWING PLAN**

RESIDENTIAL USE DEVELOPMENT  
50 THE DRIVEWAY  
OTTAWA, ONTARIO

150 Bermondsey Road, Toronto, Ontario M4A 1Y1

DESIGNED BY: DF	DATE: NOV 29, 2022	CHECKED BY: NM
DRAWN BY: DF	PROJECT No:	APPROVED BY: NM
SCALE: 1:150		DRAWING No:
© COPYRIGHT 2022 Lithos Group Ltd.	UD22-093	DD-01

18/198