

Notes:

KEY PLAN:

11500

800 8400

HSU

mm

Width : 2600  
Track : 2600  
Lock to Lock Time : 6.0  
Steering Angle : 40.0

02	Updated Site Plan	AN	2023-09-12
01	Issued for Review	AN	2023-01-27
REV:	DESCRIPTION:	BY:	DATE:
STATUS:			

**CGH Transportation**  
6 Plaza Court  
Ottawa, ON  
K2H 7W1  
(343) 999-9117

CLIENT: 2705460 Ontario Inc.

ARCHITECT:

SITE:  
**112 Montreal**

TITLE:  
**Turning Movement Analysis  
Garbage Turning Movements**

SCALE AT A3: NTS	DATE: 2023-09-12	DRAWN: AN	CHECKED: AH
PROJECT NO: 2022-109	DRAWING NO: 001	REVISION: 02	

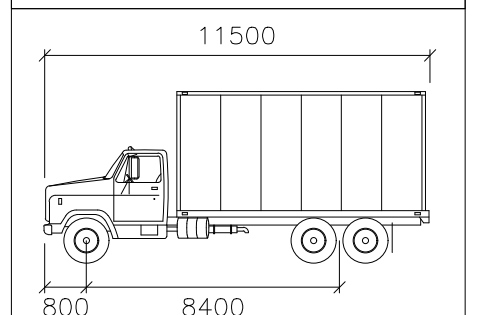
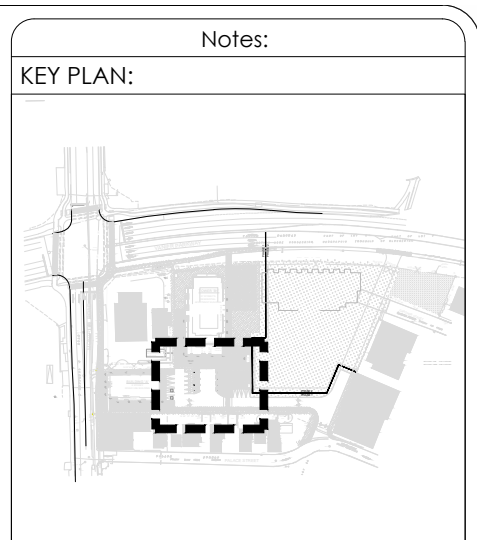
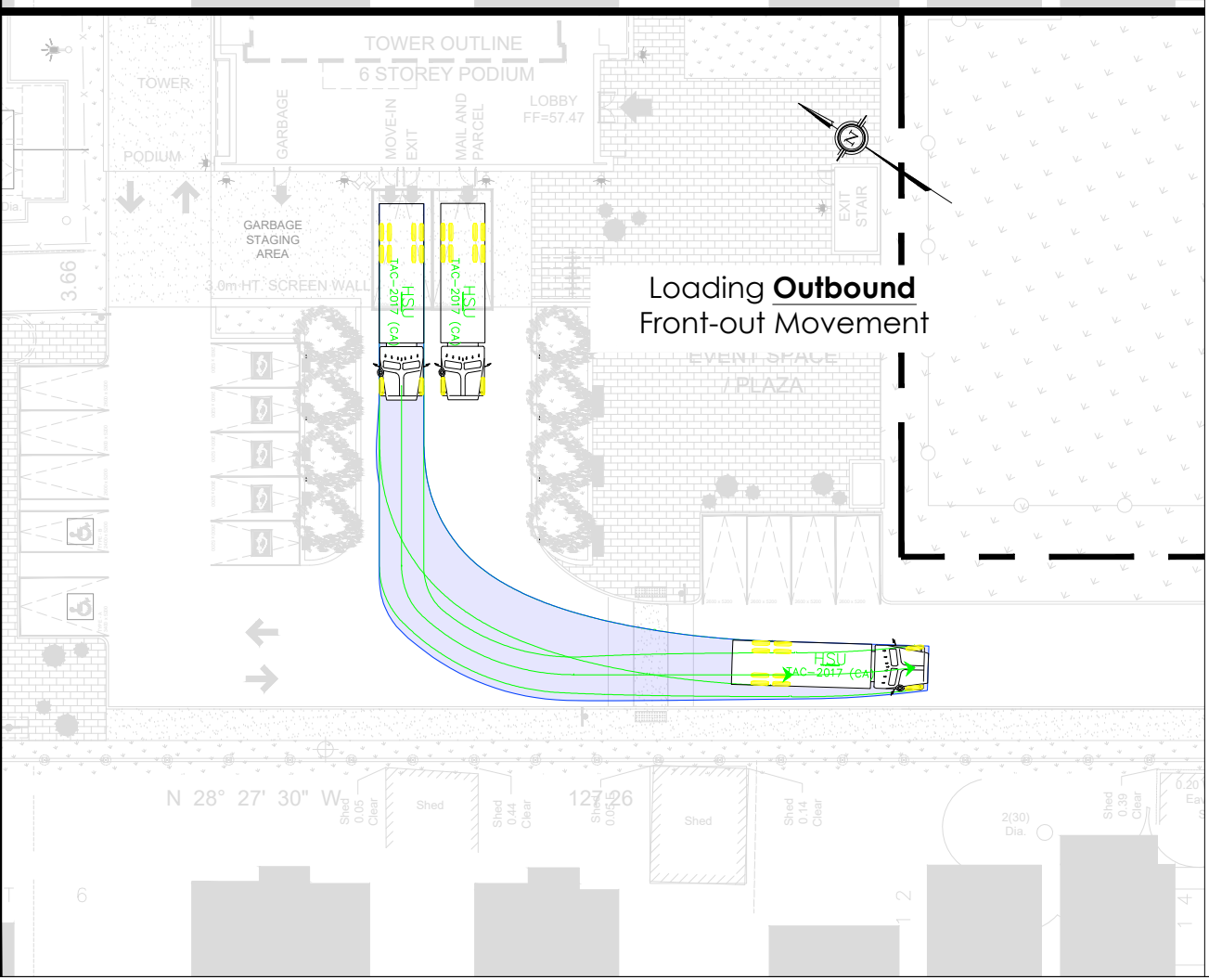
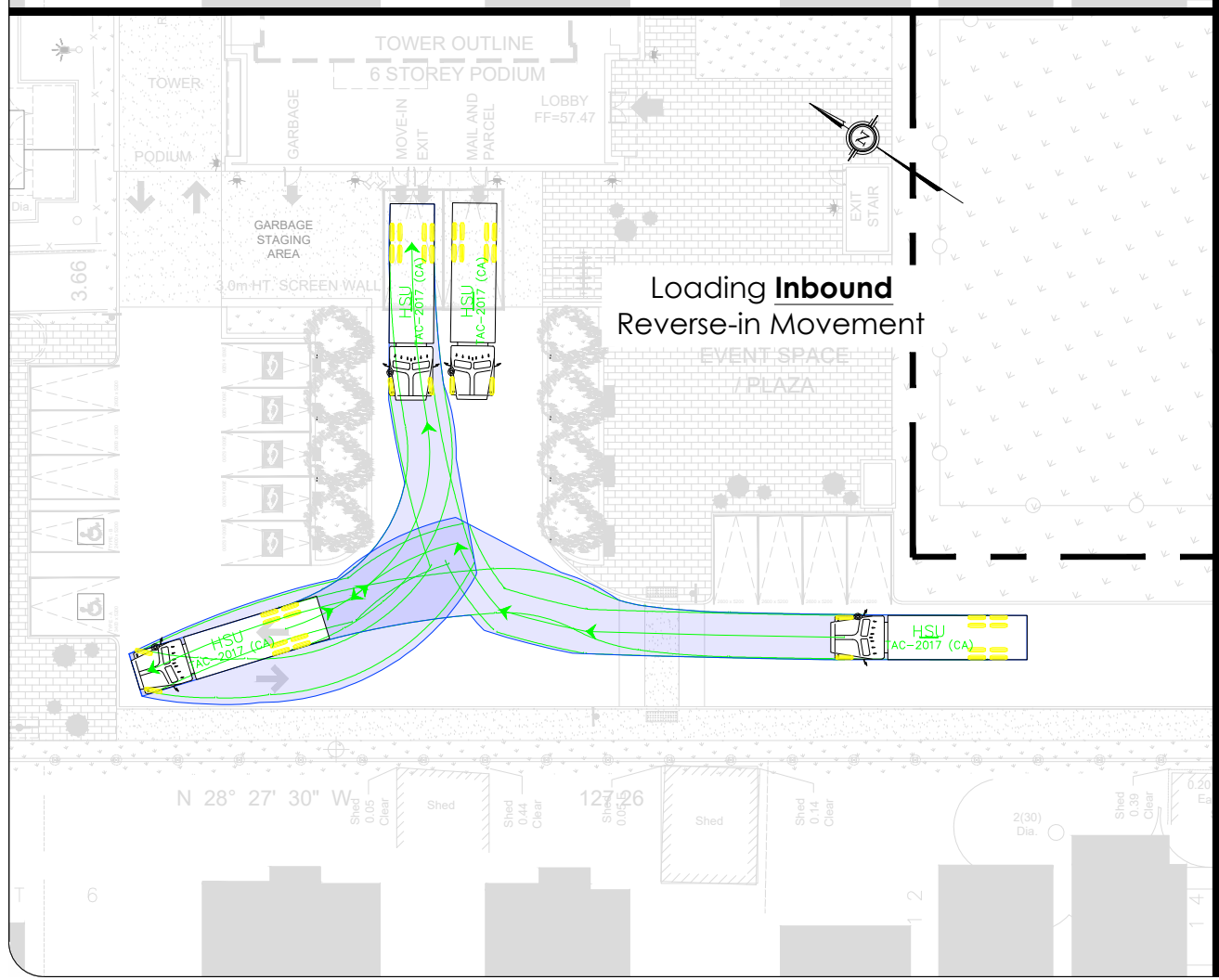
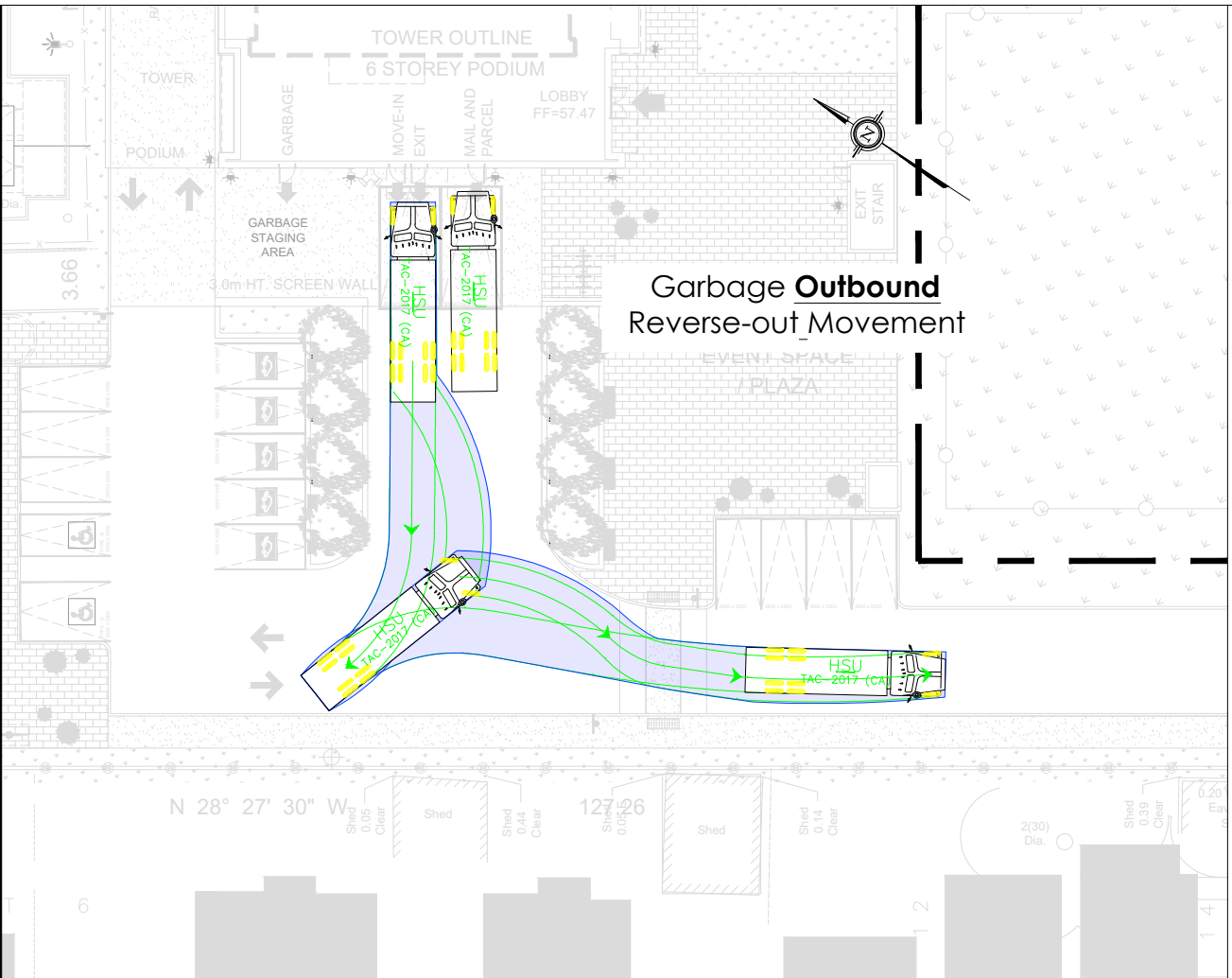
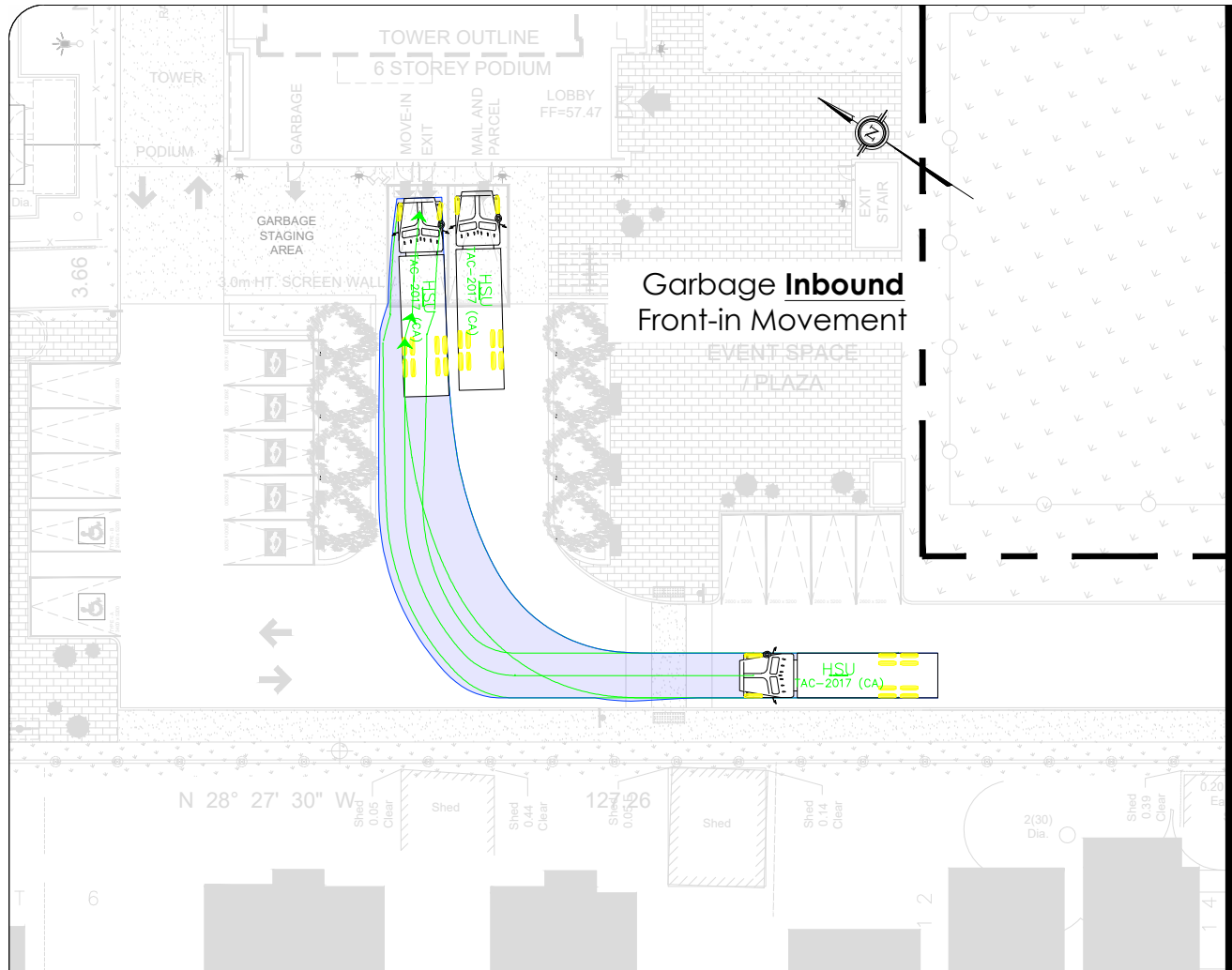

HSU

mm

Width : 2600

Track : 2600

Lock to Lock Time : 6.0

Steering Angle : 40.0

02	Updated Site Plan	AN	2023-09-12
01	Issued for Review	AN	2023-01-27
REV:	DESCRIPTION:	BY:	DATE:
STATUS:			

**CGH Transportation**  
6 Plaza Court  
Ottawa, ON  
K2H 7W1  
(343) 999-9117

CLIENT: 2705460 Ontario Inc.

ARCHITECT:

SITE: 112 Montreal

TITLE: Turning Movement Analysis  
HSU Loading Movements

SCALE AT A3:	DATE:	DRAWN:	CHECKED:
NTS	2023-09-12	AN	AH
PROJECT NO:	DRAWING NO:	REVISION:	
2022-109	002	02	

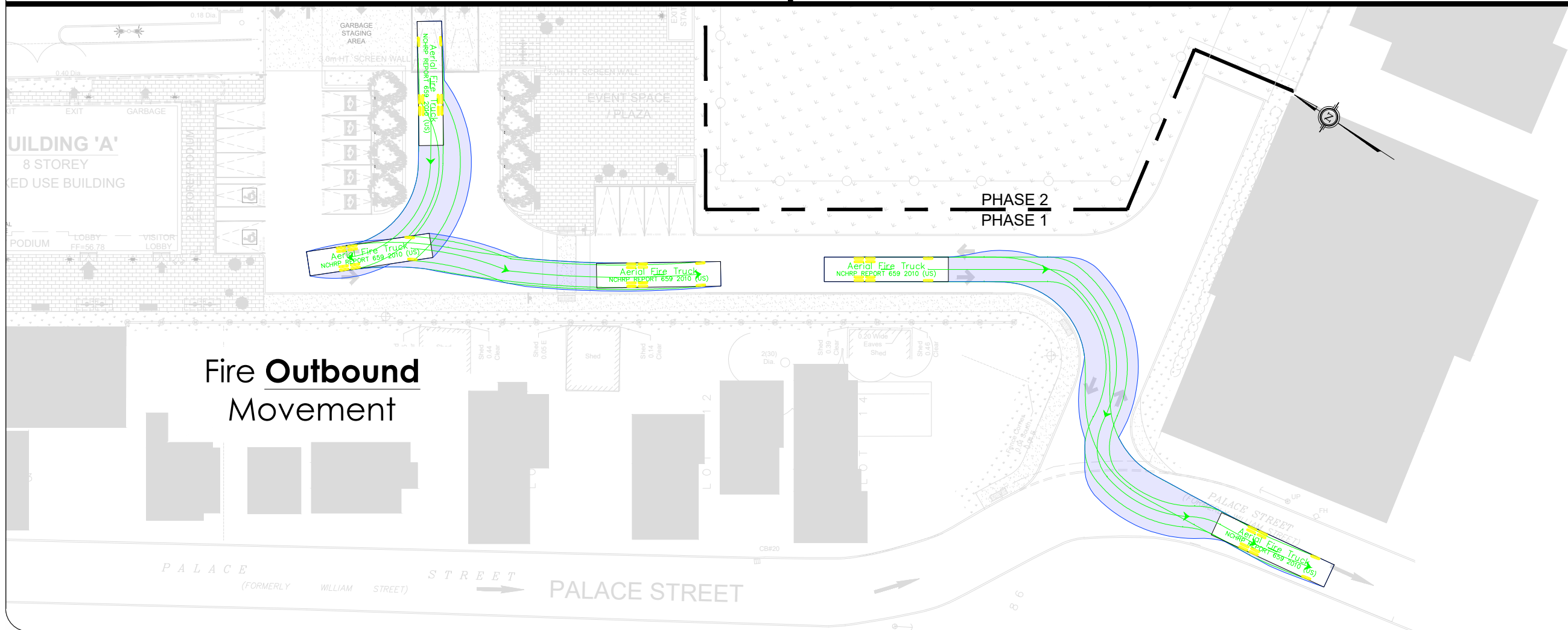
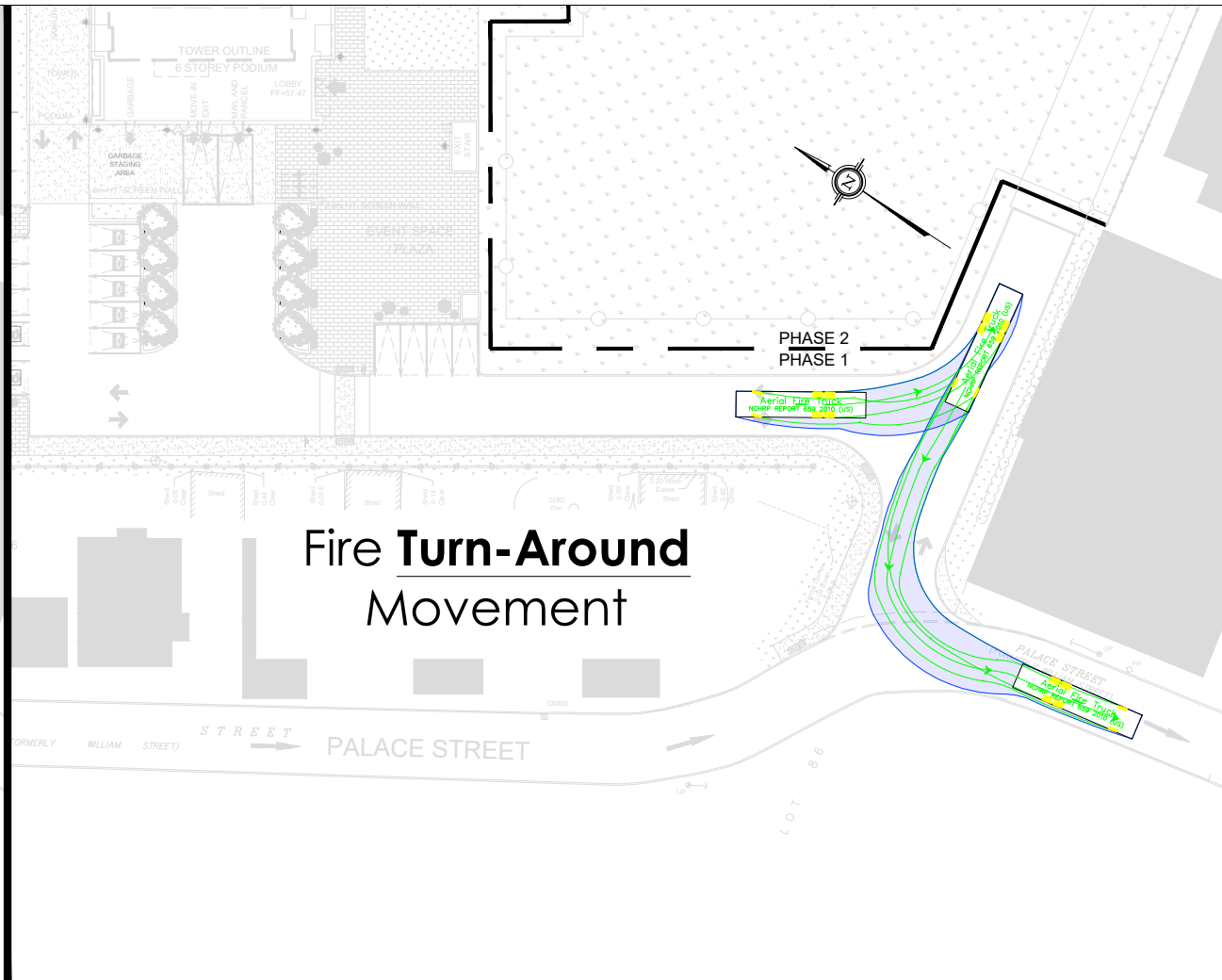
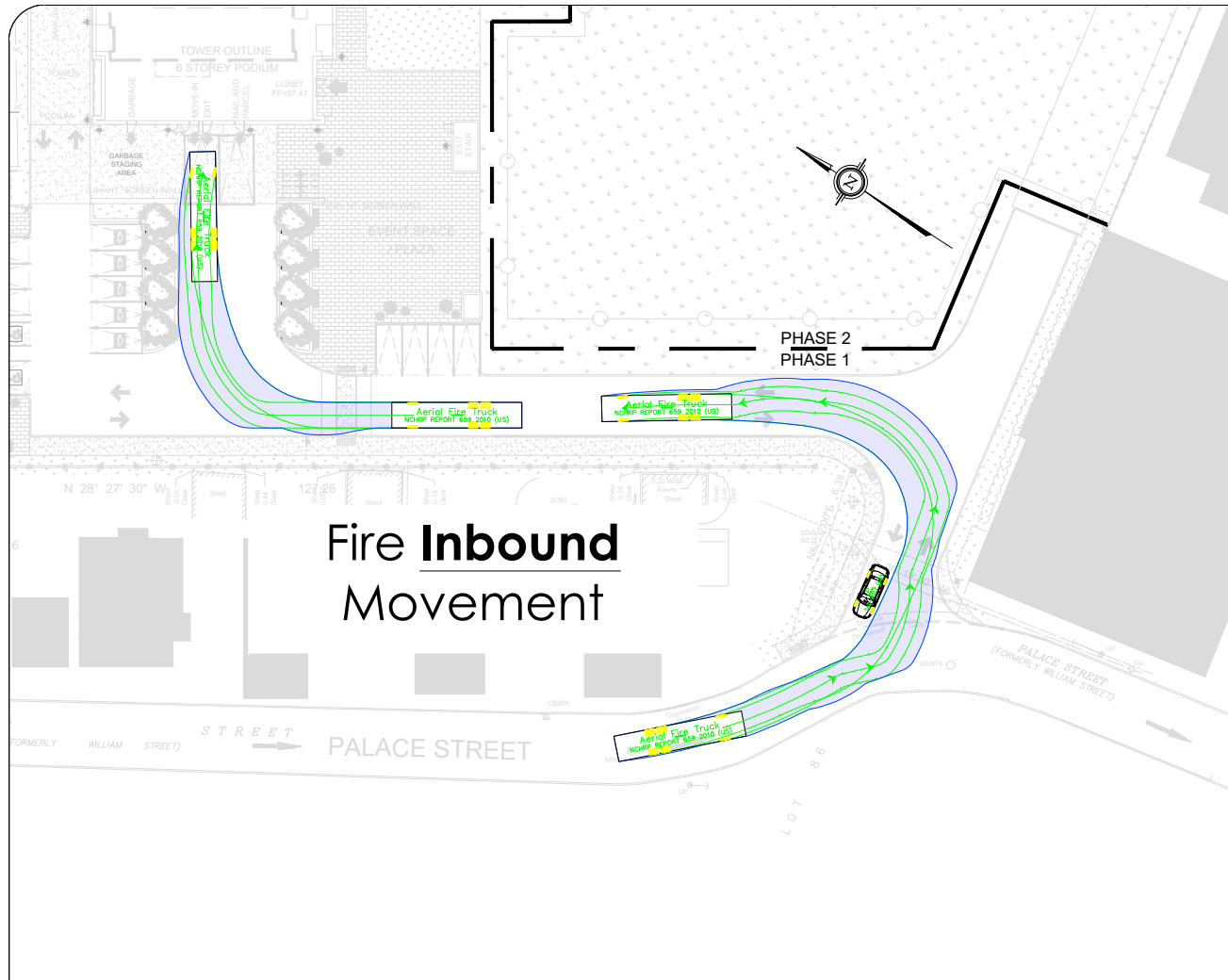

Notes:

KEY PLAN:

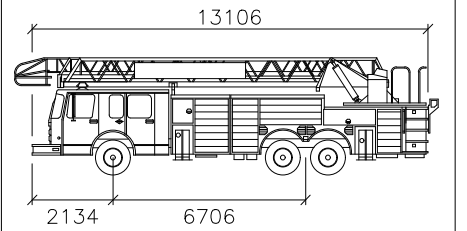
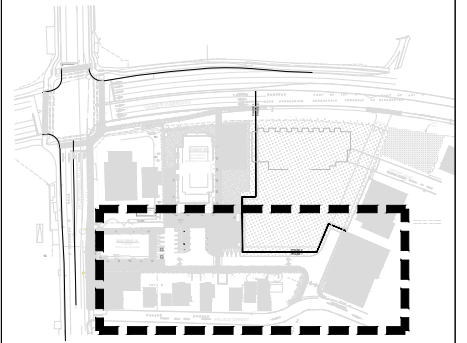

Aerial Fire Truck

mm

Width : 2591  
Track : 2591  
Lock to Lock Time : 6.0  
Steering Angle : 33.3

02	Updated Site Plan	AN	2023-09-12
01	Issued for Review	AN	2023-01-27
REV:	DESCRIPTION:	BY:	DATE:
STATUS:			

**CGH Transportation**  
6 Plaza Court  
Ottawa, ON  
K2H 7W1  
(343) 999-9117

CLIENT: 2705460 Ontario Inc.

ARCHITECT:

SITE: 112 Montreal

TITLE: Turning Movement Analysis  
Fire Turning Movements

SCALE AT A3: NTS	DATE: 2023-09-12	DRAWN: AN	CHECKED: AH
PROJECT NO: 2022-109	DRAWING NO: 003	REVISION: 02	

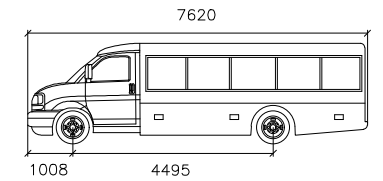
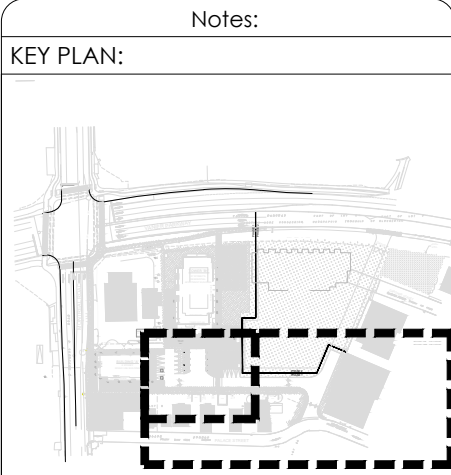
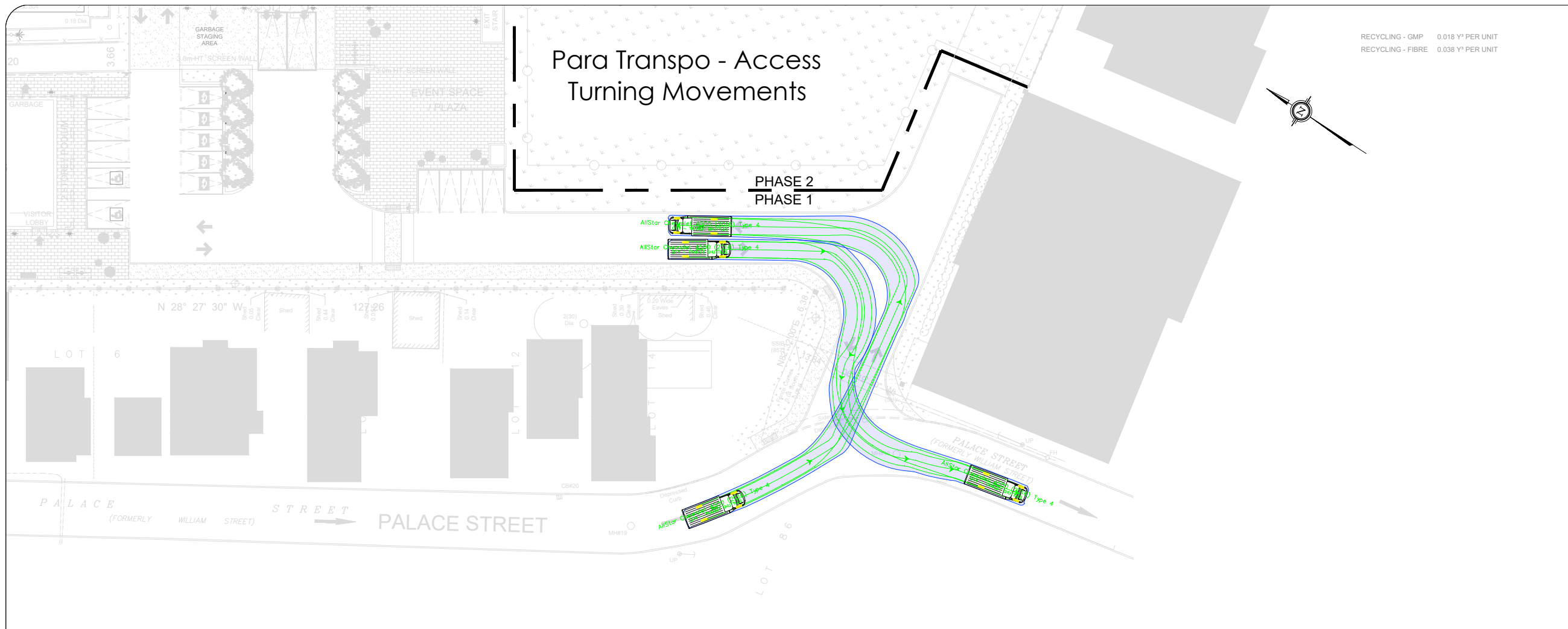

AllStar Chevrolet 4500 (2016) Type 4

Width : 2438 mm  
Track : 1957 mm  
Lock to Lock Time : 6.0  
Steering Angle : 34.2

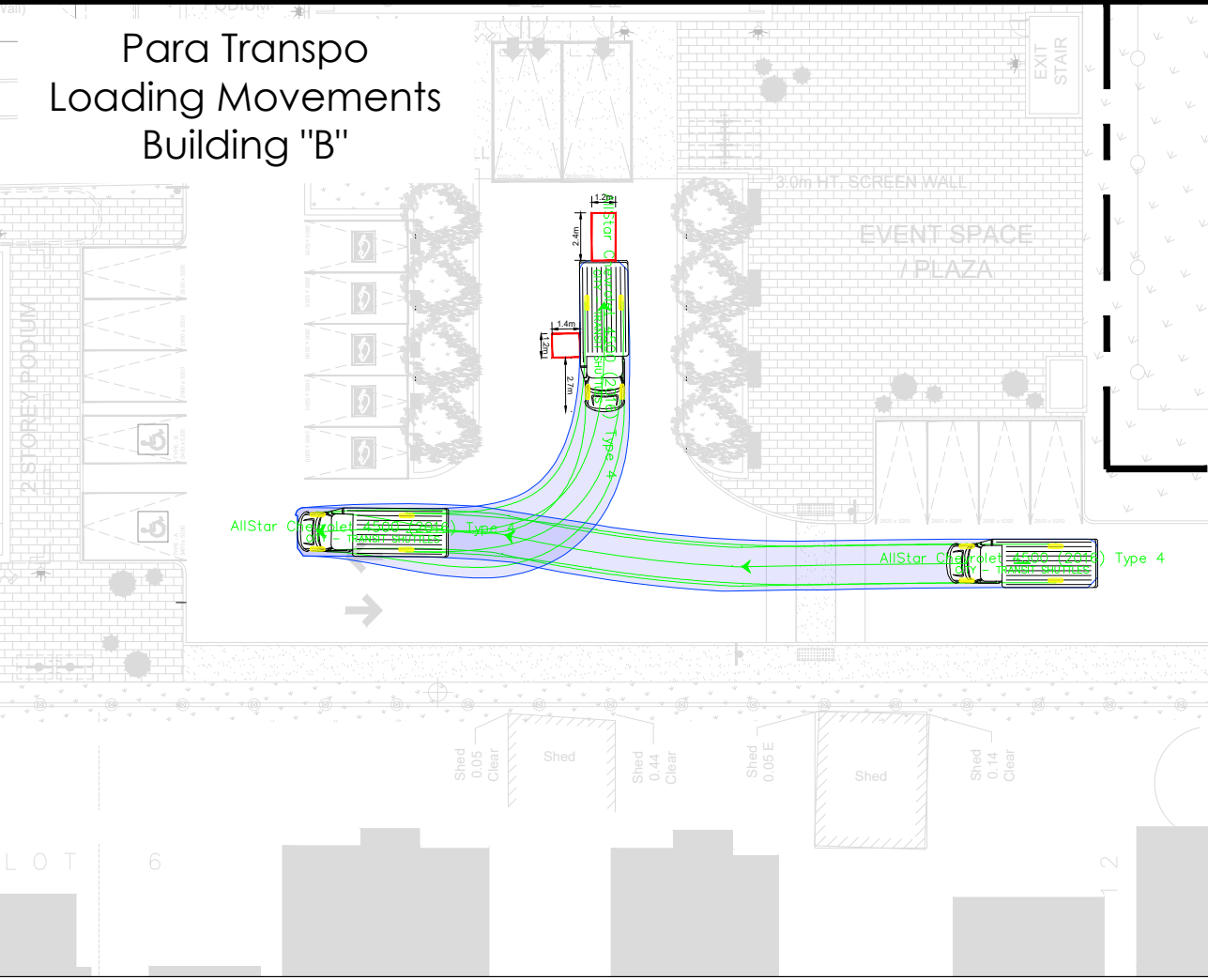
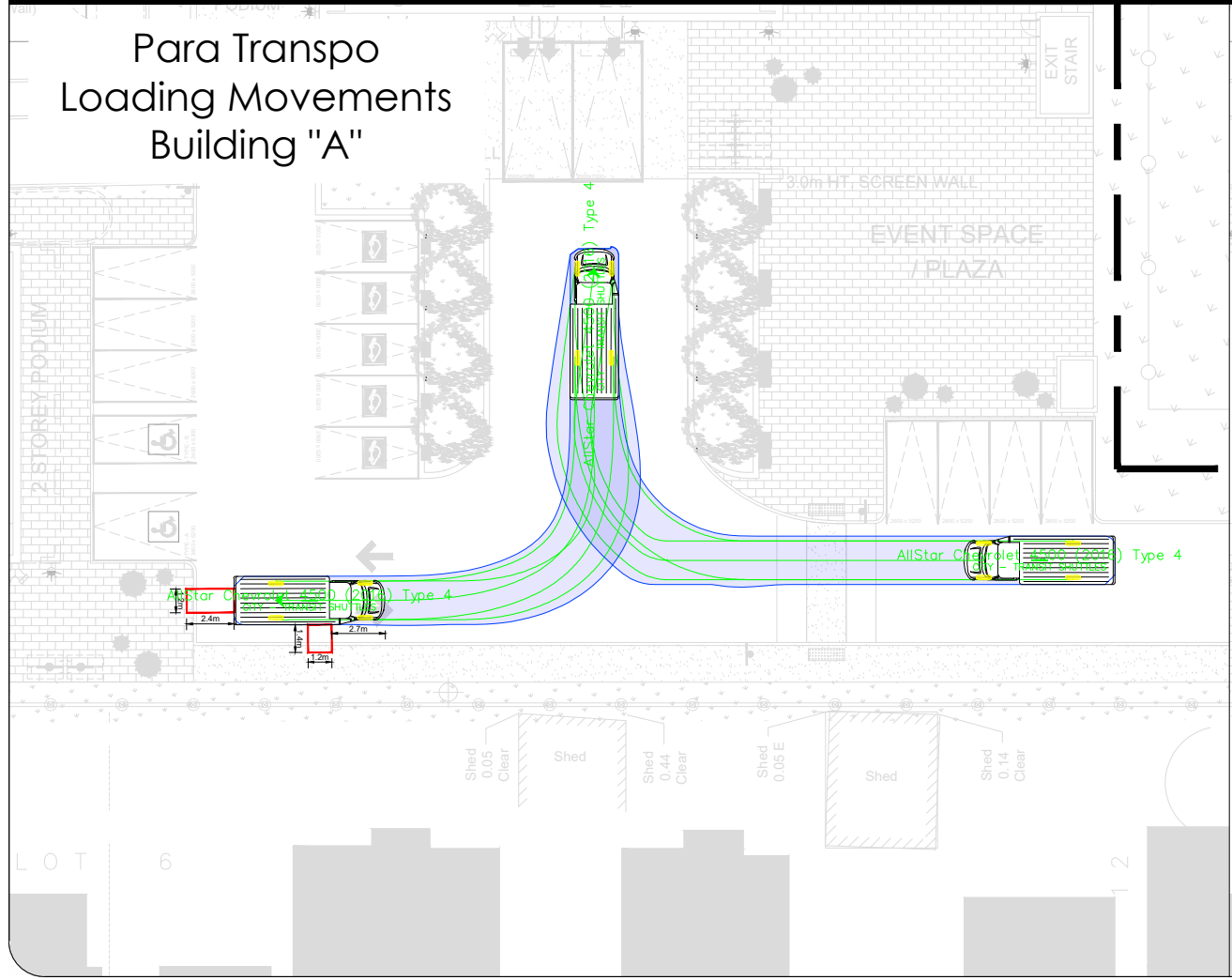

02	Updated Site Plan	AN	2023-09-12
01	Issued for Review	AN	2023-01-27
REV:	DESCRIPTION:	BY:	DATE:
STATUS:			

CGH Transportation  
6 Plaza Court  
Ottawa, ON  
K2H 7W1  
(343) 999-9117

CLIENT: 2705460 Ontario Inc.

ARCHITECT:

SITE: 112 Montreal

TITLE: Turning Movement Analysis  
Para Transpo Movements

SCALE AT A3: NTS	DATE: 2023-09-12	DRAWN: AN	CHECKED: AH
PROJECT NO: 2022-109	DRAWING NO: 004	REVISION: 02	

### HSU - City Suggested Access

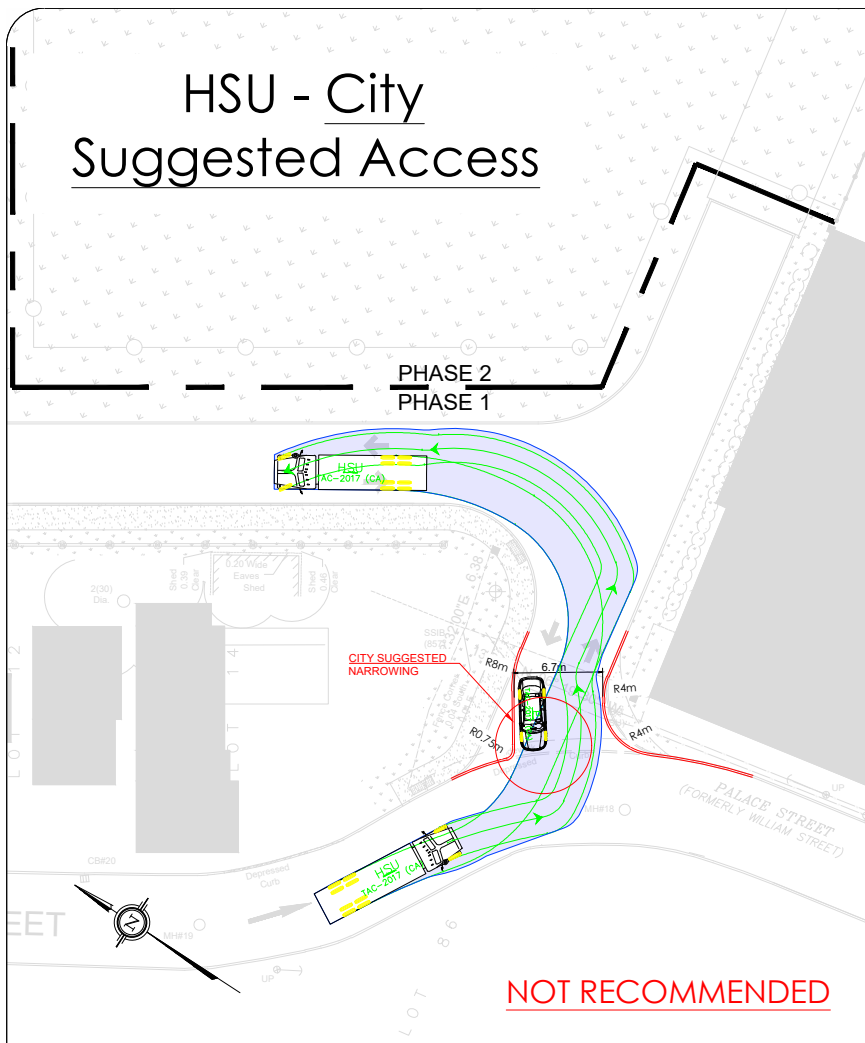

### FIRE - City Suggested Access

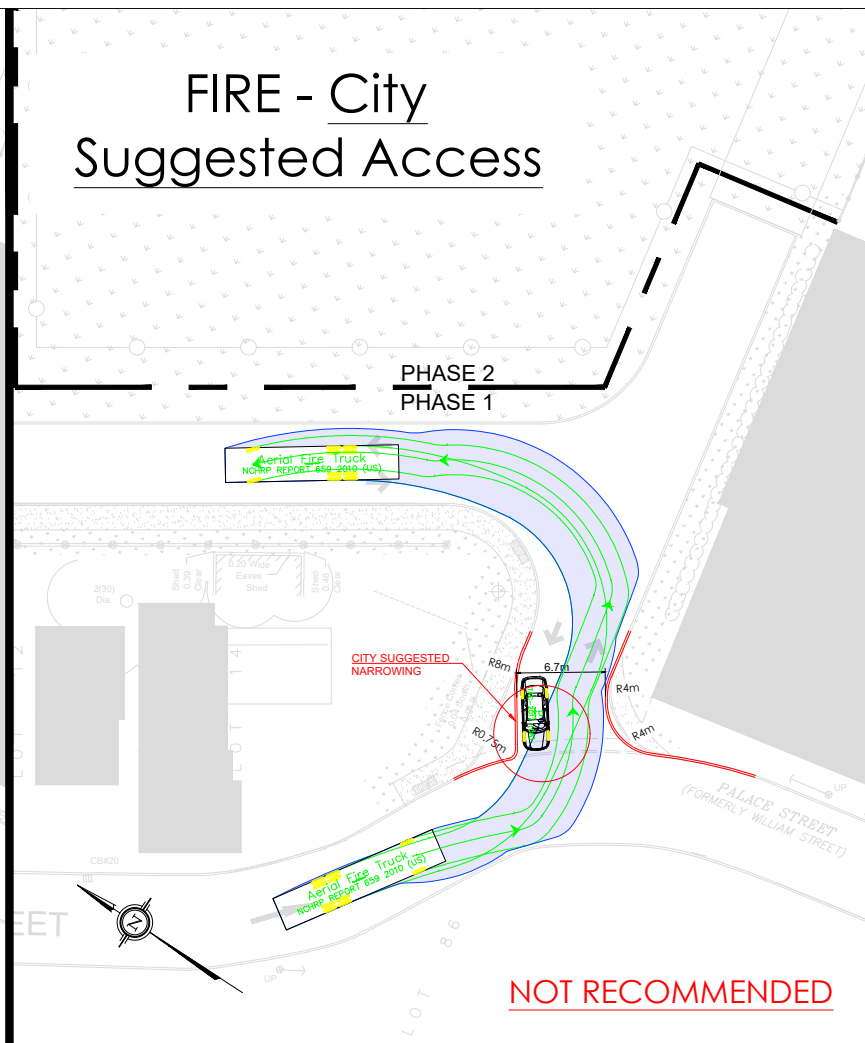

### Passenger - City Suggested Access

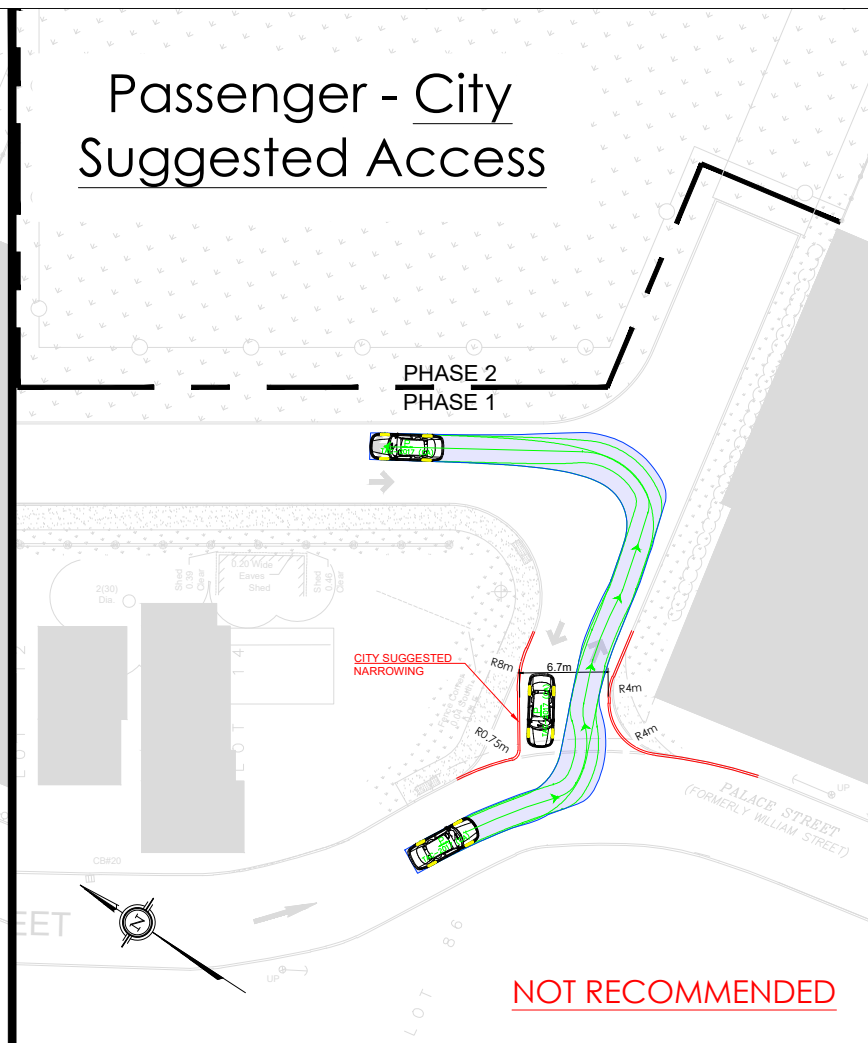

### HSU - Proposed Access

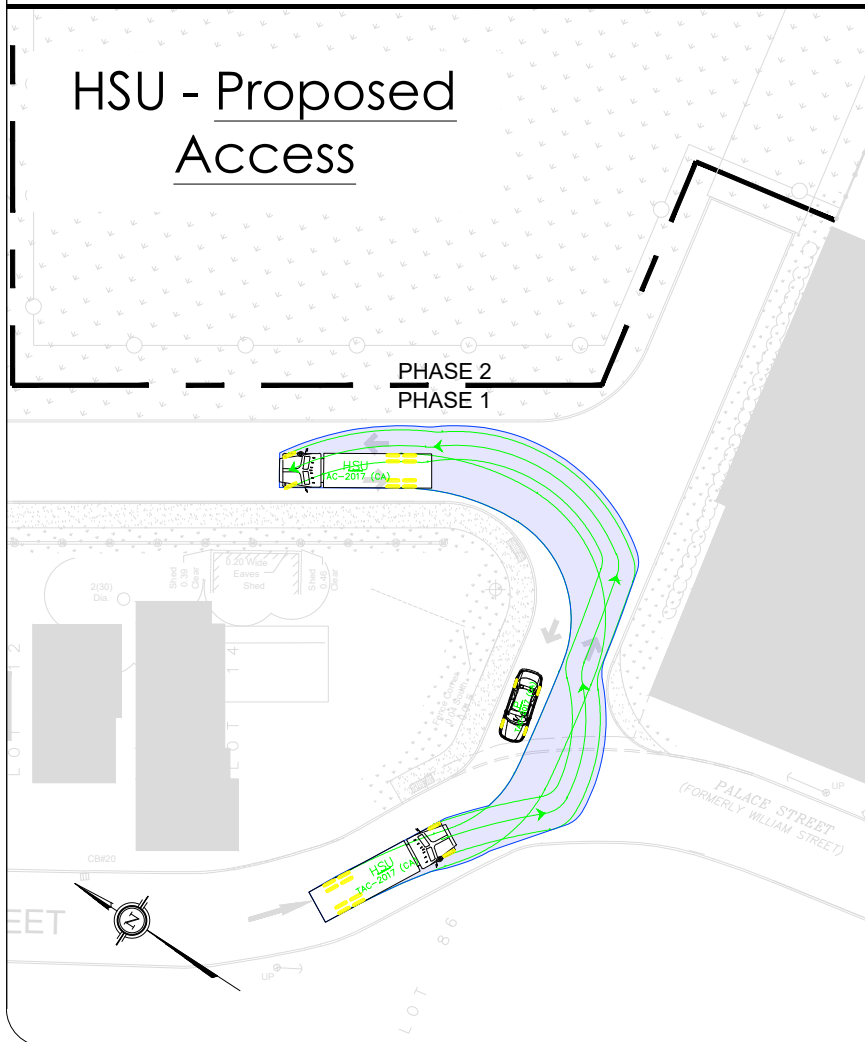

### FIRE - Proposed Access

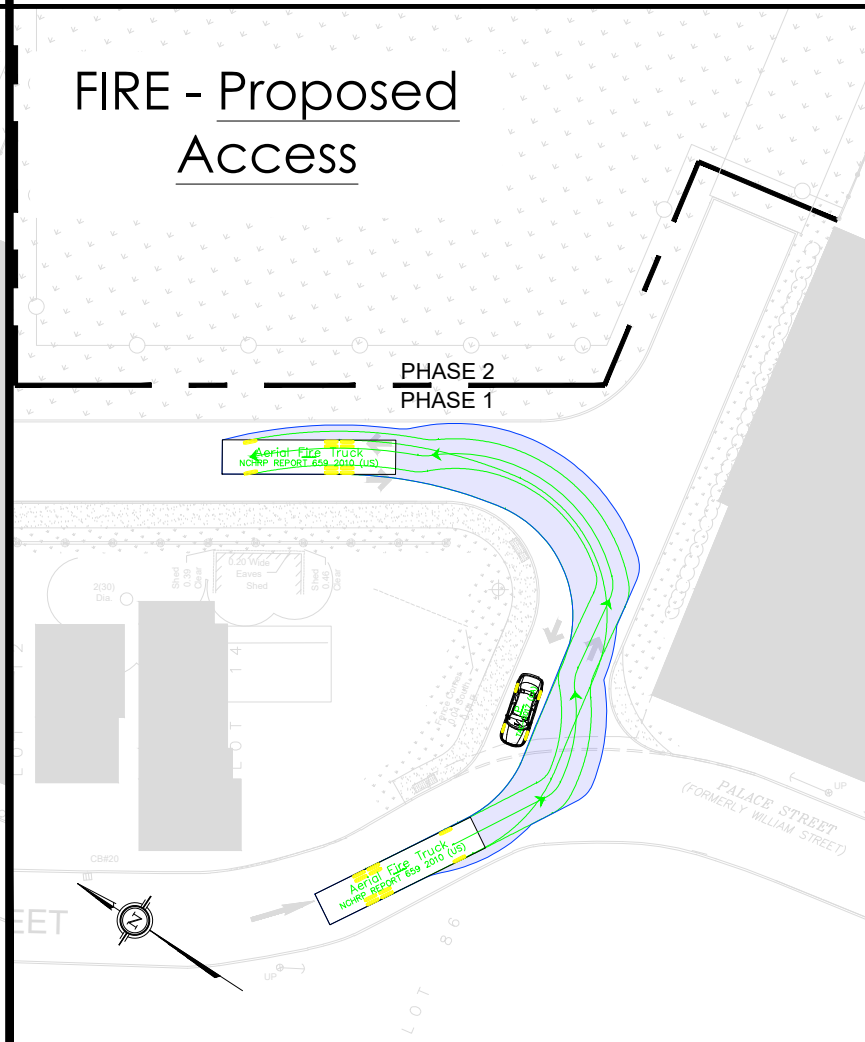

### Passenger - Proposed Access

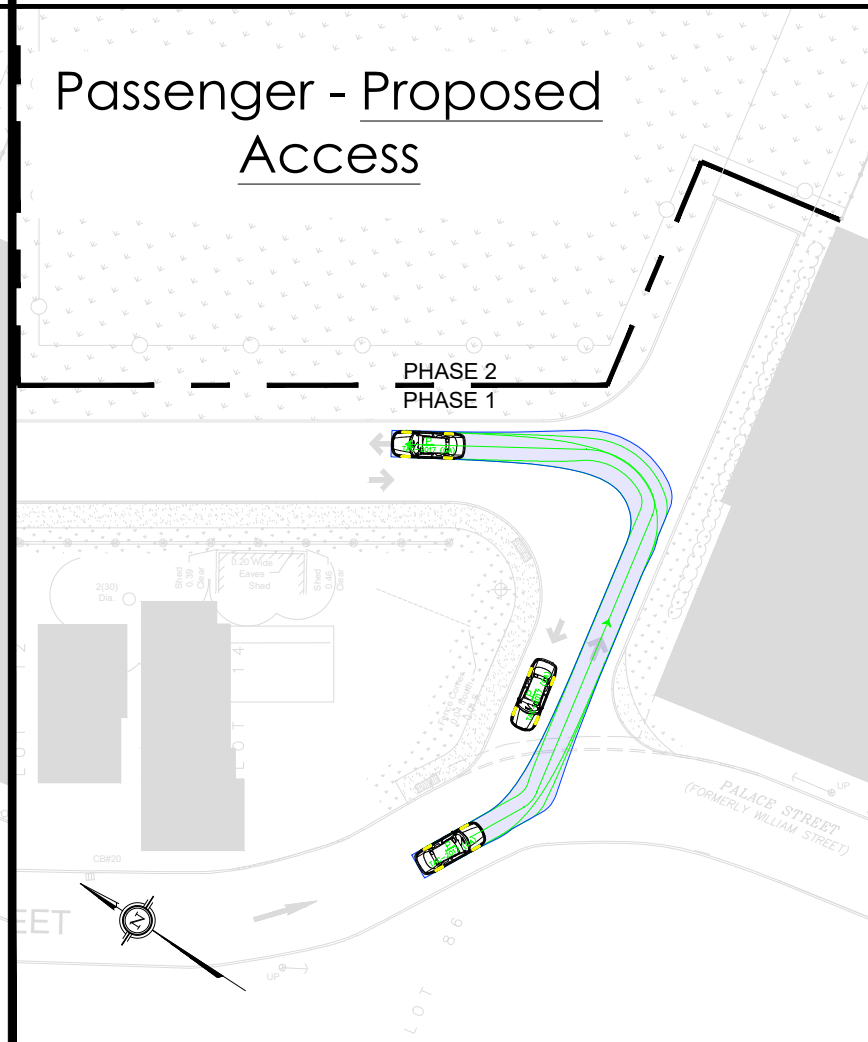

Notes:

KEY PLAN:

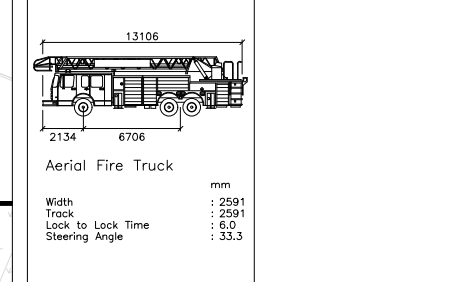
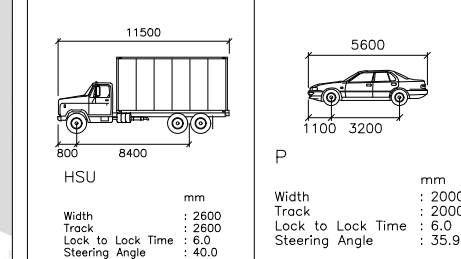
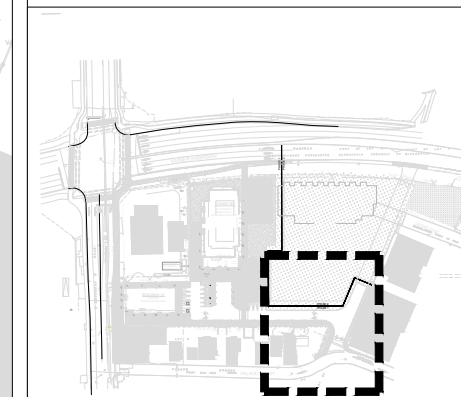

02	Updated Site Plan	AN	2023-09-12
01	Issued for Review	AN	2023-01-27
REV:	DESCRIPTION:	BY:	DATE:
STATUS:			

**CGH Transportation**  
 6 Plaza Court  
 Ottawa, ON  
 K2H 7W1  
 (343) 999-9117

CLIENT: 2705460 Ontario Inc.  
 ARCHITECT:

SITE: 112 Montreal  
 TITLE: Turning Movement Analysis  
 Proposed Access / Existing Access

SCALE AT A3:	DATE:	DRAWN:	CHECKED:
NTS	2023-09-12	AN	AH
PROJECT NO:	DRAWING NO:	REVISION:	
2022-109	005	02	