

2705460 ONTARIO INC.

112 MONTREAL ROAD STORMWATER MANAGEMENT REPORT

APRIL 03, 2023





112 MONTREAL ROAD STORMWATER MANAGEMENT REPORT

2705460 ONTARIO INC.

PROJECT NO.: 19M-01935-00
CLIENT REF:
DATE: APRIL 03, 2023

WSP
SUITE 300
2611 QUEENSVIEW DRIVE
OTTAWA, ON, CANADA K2B 8K2

T: +1 613 829-2800
F: +1 613 829-8299
WSP.COM

REVISION HISTORY

FIRST ISSUE

February 21, 2020	Draft for Client review			
Prepared by	Reviewed by	Approved By		
Michael Stewart, M.A.Sc., E.I.T. Land Development, E.I.T.	Ben Worth, P.Eng., C.Eng., MICE Manager, Water Resources	Ben Worth, P.Eng., C.Eng., MICE Manager, Water Resources		
REVISION 1				
March 6, 2020	For City Review			
Prepared by	Reviewed by	Approved By		
Michael Stewart, M.A.Sc., E.I.T. Land Development, E.I.T.	Ben Worth, P.Eng., C.Eng., MICE Manager, Water Resources	Ben Worth, P.Eng., C.Eng., MICE Manager, Water Resources		
REVISION 2				
May 7, 2021	For City Review			
Prepared by	Reviewed by	Approved By		
Julia Wansbrough, M.Sc., EIT Designer, Water Resources	Michelle Hughes, M.Sc., P.Eng. Project Manager, Water Resources	Michelle Hughes, M.Sc., P.Eng. Project Manager, Water Resources		
REVISION 3				
September 13, 2022	For City Review			
Prepared by	Reviewed by	Approved By		

Kathryn Kerker, M.A.Sc. Designer, Water Resources	Ayham Jadallah, M.Eng., P.Eng. Project Engineer, Water Resources	Ayham Jadallah, M.Eng., P.Eng. Project Engineer, Water Resources		
REVISION 4				
April 3, 2023	For City Review			
Prepared by	Reviewed by	Approved by		
Kathryn Kerker, M.A.Sc. Designer, Water Resources	Ayham Jadallah, M.Eng., P.Eng. Project Engineer, Water Resources	Ayham Jadallah, M.Eng., P.Eng. Project Engineer, Water Resources		

SIGNATURES

PREPARED BY



Kathryn Kerker, M.A.Sc.
Designer, Water Resources

April 3, 2023

Date

APPROVED¹ BY



Ayham Jadallah, M.Eng., P.Eng.
Project Engineer, Water Resources

April 3, 2023

Date

WSP Canada Group Ltd. prepared this report solely for the use of the intended recipient, 2705460 ONTARIO INC., in accordance with the professional services agreement. The intended recipient is solely responsible for the disclosure of any information contained in this report. The content and opinions contained in the present report are based on the observations and/or information available to WSP Canada Group Ltd. at the time of preparation. If a third party makes use of, relies on, or makes decisions in accordance with this report, said third party is solely responsible for such use, reliance or decisions. WSP Canada Group Ltd. does not accept responsibility for damages, if any, suffered by any third party as a result of decisions made or actions taken by said third party based on this report. This limitations statement is considered an integral part of this report.

The original of this digital file will be conserved by WSP Canada Group Ltd. for a period of not less than 10 years. As the digital file transmitted to the intended recipient is no longer under the control of WSP Canada Group Ltd., its integrity cannot be assured. As such, WSP Canada Group Ltd. does not guarantee any modifications made to this digital file subsequent to its transmission to the intended recipient.

¹ Approval of this document is an administrative function indicating readiness for release and does not impart legal liability on to the Approver for any technical content contained herein. Technical accuracy and fit-for-purpose of this content is obtained through the review process. The Approver shall ensure the applicable review process has occurred prior to signing the document.



TABLE OF CONTENTS

1	INTRODUCTION	1
1.1	Scope	1
1.2	Site Location	1
1.3	Stormwater Management Plan Objectives	2
1.4	Design Criteria	2
2	PRE-DEVELOPMENT CONDITIONS	3
2.1	General	3
2.2	Rainfall Information	3
2.3	Allowable Flow Rates	3
3	POST-DEVELOPMENT CONDITIONS	4
3.1	General	4
3.2	Quantity Control	4
3.3	Water Quality Control	6
3.4	Erosion Control	6
4	RIDEAU RIVER FLOOD PLAIN	7
5	CONCLUSIONS	8

TABLES

TABLE 2-1: PRE-DEVELOPMENT PEAK FLOW RATE CALCULATIONS (RUNOFF COEFFICIENT, C = 0.50 AND T _c =20 MIN)	3
TABLE 3-1 POST-DEVELOPMENT MODELLING RESULTS (A)	5
TABLE 3-2 POST-DEVELOPMENT MODELLING RESULTS (B)	5
TABLE 3-3: POST-DEVELOPMENT MODELLING RESULTS (C)	6

FIGURES

FIGURE 1: SITE LOCATION	1
-------------------------------	---

APPENDICES

A	RVCA CORRESPONDENCE
B	EXISTING SITE CONDITIONS
C	PRE-DEVELOPMENT CALCULATIONS
D	PROPOSED SITE DRAWINGS
E	CATCHMENT PLAN
F	SUPPORTING DOCUMENTS
F-1	HYDRO-BRAKE RATING CURVE
F-2	WATTS ACUTROL ROOF DRAIN
F-3	STORMTECH CHAMBER
G	HYDROCAD MODEL OUTPUT
G-1	5-YEAR ANALYSIS (PEAK DISCHARGE)
G-2	100-YEAR ANALYSIS (PEAK DISCHARGE)
G-3	100-YEAR ANALYSIS (PEAK CHAMBER STORAGE)
G-4	100-YEAR ANALYSIS (PEAK ROOF STORAGE)
H	FLOOD PLAIN MAPPING AND ELEVATIONS

1 INTRODUCTION

1.1 SCOPE

WSP Canada Group Ltd. was retained by 2705460 Ontario Inc. to conduct a stormwater management study to service the proposed redevelopment of the existing Econolodge site into a new group of residential towers.

1.2 SITE LOCATION

The existing site is located at 112 Montreal Road in Ottawa, Ontario, close to the south-west corner of the Montreal Road and Vanier Parkway intersection. The location of the proposed re-development is illustrated in **Figure 1**.

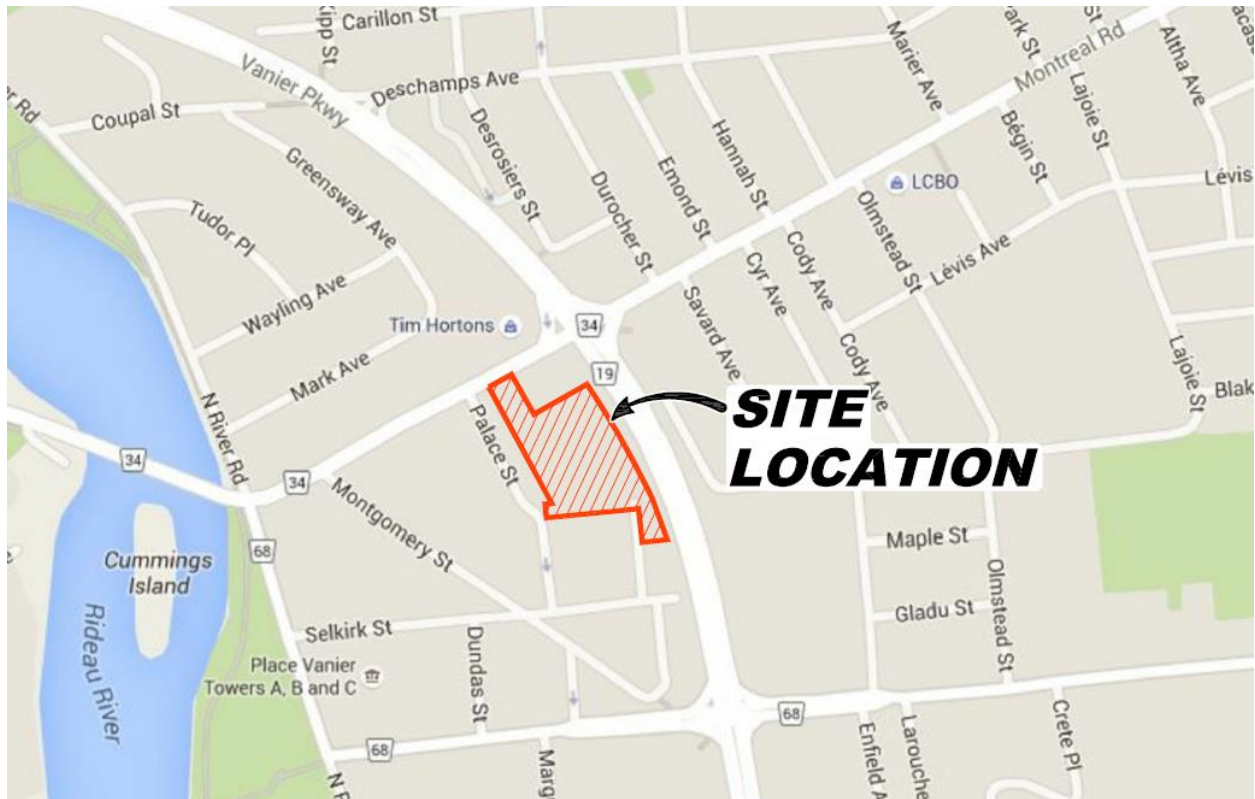

Figure 1: Site Location

1.3 STORMWATER MANAGEMENT PLAN OBJECTIVES

The objectives of the stormwater management plan are as follows:

- Determine site specific stormwater management requirements to ensure that the plan is in conformance with the City of Ottawa Sewer Design Guidelines, October 2012.
- Prepare a stormwater management report documenting the strategy along with the technical information necessary for the justification and sizing of the proposed stormwater management facilities.

1.4 DESIGN CRITERIA

The City of Ottawa (the City) was contacted to determine the stormwater management (SWM) requirements for discharge into the local City sewers for the project site. Joshua White at the City specified that flows greater than the 5-year flow generated from a runoff coefficient of 0.50 must be controlled on site up to the 100-year return period (consistent with Section 8.3.7.3 of the Ottawa Sewer Design Guidelines, October 2012).

The runoff coefficient used for design (100-year return period), was increased by 25% to comply with section 5.4.5.2.1 of the Ottawa Sewer Design Guidelines (October 2012).

As per section 8.3.7 of the Ottawa Sewer Design Guidelines “New development draining to an existing system that has no stormwater treatment facility may be subject to on-site treatment (i.e. best management practice, oil grit separators, etc.). Some existing areas within the City may be subject to a cash-in-lieu policy with respect to stormwater treatment. The designer must confirm with the City if the development area in question is subject to this policy”. The City directed WSP to contact the Rideau Valley Conservation Authority (RVCA) to determine any applicable water quality criteria to be used in the design. The RVCA specified no treatment criteria for this site. A record of this conversation has been included in **Appendix A**. Similarly, the City has not specified any water quality requirements for use at this site. Therefore, none have been specifically included in the design.

In summary, the design criteria for stormwater management at the site are:

- Control the 100-year outflow from the site to the 5-year flow using a runoff coefficient of 0.50 and a T_c of 20 minutes; and
- No water quality treatment is required.

2 PRE-DEVELOPMENT CONDITIONS

2.1 GENERAL

The subject property pre-development includes an impervious at-grade parking lot, an existing group of commercial buildings (Econolodge) and a pervious landscaped area at the south-east corner of the project site. The total site area is 1.22 ha. Please refer to **Appendix B** for existing site conditions.

2.2 RAINFALL INFORMATION

The rainfall intensity is calculated in accordance with Section 5.4.2 of the Ottawa Sewer Design Guidelines (October 2012):

$$i = \left[\frac{A}{(Td + C)^B} \right]$$

Where;

- A, B, C = regression constants for each return period (defined in section 5.4.2)
- i = rainfall intensity (mm/hour)
- Td = storm duration (minutes)
- The IDF parameters/regression constants are included in **Appendix C**.

2.3 ALLOWABLE FLOW RATES

As noted in section 1.4, the City of Ottawa specified the allowable discharge rate from this site as the 5-year flow generated from a runoff coefficient of 0.50, controlled on site up to the 100-year return period.

The allowable release rate to the municipal storm sewer system from the proposed development is 119 l/sec, based on the 5-year pre-development flow rate calculated with a runoff coefficient value of 0.50.

The calculated peak flow rates for the site in the pre-development condition are summarized below in Table 2-1. Detailed calculations are contained within Appendix C.

Table 2-1: Pre-Development Peak Flow Rate Calculations (Runoff Coefficient, C = 0.50 and T_c=20 min)

RETURN PERIOD (YEARS)	RAINFALL INTENSITY (MM/HOUR)	PEAK FLOW RATE (L/SEC)	TARGET RELEASE RATE (L/SEC)
2	52.0	88.2	119.0
5	70.3	119.0	
10	82.2	139.3	
25	97.3	164.8	
50	108.5	183.8	
100	120.0	203.2	

3 POST-DEVELOPMENT CONDITIONS

3.1 GENERAL

The project proposals consist of a mixed-use development with 2 towers; a 37-storey residential tower (Tower B1), and an 8-storey mixed use building (Tower A). A multi-level basement structure is proposed over the majority of the project site area. As described further in subsequent sections of the report, a SWM underground storage chamber will be provided at the south end of the site with a connection to Montreal Road. Please refer to **Appendix D** for an illustration of the project (Storm Drainage Area Plan).

The analysis for the site and the sizing of the underground storage chamber has been completed with provisions for future development in the southeast quadrant of the site. A runoff coefficient of 0.8 has been assigned to represent the future land-use in this area (S06 and S07 on the Storm Drainage Area Plan).

The following assumptions have been used to quantify stormwater runoff for modelling/analysis purposes: 100% of proposed roof surfaces have been considered as impervious, and the top level of the rooftop area of each tower will be available for temporary surface ponding (via drainage by controlled discharge roof drains).

The entire project area will comply with the target allowable release rate.

3.2 QUANTITY CONTROL

As noted in section 2.3, the target allowable discharge rate to the municipal sewer system from the site is 119 L/sec. This is equivalent to the peak runoff rate under pre-development conditions during a 5-year design storm event with a runoff coefficient of 0.50. Compliance with the target offsite discharge rate will be achieved through use of controlled flow rooftop drains, and the provision of an underground storage chamber. Post-development runoff calculations have accounted for uncontrolled runoff from portions of the site that will not drain to storage features.

An underground storage chamber was identified as the preferred storage option given the substantial underground parking requirement for the site; surface storage was not considered a viable option and was not accounted for in this analysis.

The underground storage chamber is designed to receive runoff (for all events up to and including the 100-year return period), from roof surfaces and at-grade areas within the development area. The controlled and uncontrolled project areas are illustrated in **Appendix E**. The underground storage chamber will discharge to the existing municipal storm sewer system via gravity, and peak outflow rates will be controlled via a vortex flow control device (**Appendix F**).

To satisfy net target release rates for controlled and uncontrolled site areas, the recommended peak discharge rate for flow control device is 112 L/sec. If a storm event that occurs fills the underground storage chamber, the access hatch at the top of the underground storage chamber would allow water to spill to the Palace Street major system. It is noted that the return period associated with an overflow event requiring these facilities to spill would exceed 100-years.

As per the Site Servicing Plan Drawing, discharge from the underground storage chamber is proposed to the Montreal Road trunk storm sewer. This trunk storm sewer is 1050mm and it is believed that the City's flow control requirements for the site (which currently drains to this same storm sewer) are sufficient to ensure that there will be no adverse surcharging of the storm sewer.

As noted above, the top level of the rooftop area of each tower will be available for temporary surface ponding (via drainage by controlled discharge roof drains), and the remaining roof areas will drain directly to the underground storage chamber without any rooftop storage. Calculations were done based on the roof drain layouts, with five roof drains on Tower A and four roof drains on Tower B1. For modelling purposes, these outlets were simulated using rating curves for a *Watts Accutrol* product (in the "fully closed" position) (**Appendix F**).

Appendix E illustrates the small portions of the project site that will drain offsite uncontrolled in post-development conditions. These uncontrolled runoff rates contribute to the total allowable release rate modelled.

A HydroCAD model of the project was constructed and utilized to include:

- storage and controlled release of stormwater from top level of rooftop areas (Towers A and B1) to the underground storage chamber;
- runoff from the remaining rooftop areas (Towers A and B1) directly to the underground storage chamber;
- controlled runoff from at-grade areas directed to the underground storage chamber; and
- uncontrolled runoff rates generated from at grade areas (S08 and S09)

The Modified Rational Method (an inherent subroutine of the HydroCAD software) has been used for the modelling exercise, and the model has informed the maximum storage volume used in the stormwater underground storage chamber based on the proposed flow. Flow rates generated from uncontrolled drainage areas within the project site and controlled flow from the underground storage chamber meet the target offsite discharge rate required (119 l/s).

The rainfall intensity and storm duration combination resulting in the largest peak flow discharged to the sewer system occurs at the critical storm duration, $t_d = 10$ minutes for the 100-year event (determined iteratively using HydroCAD). A summary of the model results and storage controls are listed in **Table 3-1** to **Table 3-3** and the full modelling output is included in **Appendix G**.

The modelled post-development peak flow rates comply with the allowable release rate for the 100-year return period (**Table 3-1**).

Table 3-1 Post-Development Modelling Results (A)

RETURN PERIOD (YEARS)	MODELLED POST-DEV. PEAK FLOW RATE (L/SEC) ¹	ALLOWABLE RELEASE RATE (L/SEC)
5	110	119
100	119	

¹ Includes flow rates generated from uncontrolled drainage areas within the project site and controlled flow from the underground storage chamber

The HydroCAD analysis completed allows the performance of the SWM drainage system to be verified in all possible storm durations (based on Modified Rational method calculations) and helps identify the critical duration for different components of the system. For example, the critical storm duration for the underground storage chamber (resulting in maximum storage utilized) was found to be $t_d = 30$ minutes. A summary of these modelling results is provided below.

The results show that the maximum utilized storage volume in the underground storage chamber is 312 m³ to control the 100-year post-development runoff (**Table 3-2**). Details for the proposed Stormtech chambers are included in **Appendix F-3**.

Table 3-2 Post-Development Modelling Results (B)

RETURN PERIOD (YEARS)	MAXIMUM UTILIZED STORAGE AND ASSOCIATED PEAK FLOW (L/S)	
	(m ³)	(L/s)
100	312	112

¹ Critical duration resulting in maximum storage utilized in the underground storage chamber

Maximum rooftop storage volumes and release rates (based on the critical duration for each of the different components of the system), in addition to uncontrolled flow rates generated from uncontrolled areas are provided in **Table 3-3**.

Table 3-3: Post-Development Modelling Results (C)

RETURN PERIOD (YEARS)	ROOFTOP MAXIMUM STORAGE VOLUME, PEAK RELEASE RATE ¹ , AND PONDING DEPTH						UNCONTROLLED FLOW RATE ² (L/S)
	TOWER A			TOWER B1			
	(m ³)	(L/s)	(m)	(m ³)	(L/s)	(m)	
5	4.5	1.5	0.054	6.4	1.2	0.073	2.9
100	11.5	1.5	0.086	15.4	1.2	0.142	8.3

¹ Based on the critical duration resulting in maximum storage utilized on each roof surface

² Based on the critical duration resulting in the maximum flow released from the site

3.3 WATER QUALITY CONTROL

As per Section 1.4, no water quality treatment is required.

3.4 EROSION CONTROL

Please refer to the Erosion and Sedimentation Control plan drawing C.05 as part of the Engineering Drawing Set.

4 RIDEAU RIVER FLOOD PLAIN

The RVCA were consulted to obtain flood plain mapping for the Rideau River in the vicinity of the subject site. Please refer to mapping excerpt provided in **Appendix H**.

It is noted that the 100-year flood plain extends onto Montreal Road, to a modelled elevation of 56.52 m (cross section reference 2474). The site design has accounted for this by setting the minimum ground elevation at the project threshold to an elevation of 56.62 m (refer to Grading and Drainage Plan Drawing C.02 for details), and by specifying the use of non-return backflow preventers within the flow control device associated with the underground storage chamber.

5 CONCLUSIONS

A stormwater management plan has been prepared to support the site plan application for the 112 Montreal Road development in the City of Ottawa. The key points are summarized below.

WATER QUANTITY

Controlled runoff collected from the project site will be directed to a stormwater underground storage chamber with a minimum active storage volume of 312 m³ to control the 100-year event. Discharge from the underground storage chamber to the municipal storm sewer will be controlled using a vortex flow control device (specified with a peak discharge rate of 112 l/sec).

For the 100-year return period, the uncontrolled runoff (S08 and S09) and flow controlled from the underground storage chamber directed to the municipal storm sewer system will comply with the allowable 5-year release rate of 119 L/sec (calculated using a runoff coefficient of 0.50 and a T_c of 20 minutes).

WATER QUALITY

No specific water quality treatment features are required.

This report demonstrates that the proposed SWM strategy will address stormwater management related impacts from this project and meet the requirements of the City of Ottawa.

APPENDIX

A

RVCA
CORRESPONDENCE



1145 Hunt Club Road, Suite 300
Ottawa, Ontario K1V 0Y3
Tel: (613) 736-7200
Fax: (613) 736-8710

TELECOM RECORD

W.O.: 1013081
DATE: August 11, 2014
TIME: 2:30
CALL FROM: Bryan Orendorff
REPRESENTING: MMM
CALL TO: Brandon Williams
REPRESENTING: RVCA

REGARDING: SWM requirements for proposed 112 Montreal Road Development

DISCUSSION: MMM contacted the RVCA to determine if they had any SWM requirements for the proposed site. The City had previously directed MMM to take this action. Brandon replied that the RVCA did not anticipate any involvement was required on their part for this site from a floodplain perspective (the site is outside the floodplain) and that they typically would not comment on a site application until it was circulated to them by the City. He indicated that the RVCA in this case could rely on the City to ensure that all appropriate requirements were being met.

ACTION: No actions required.

CC:

APPENDIX

B

EXISTING SITE CONDITIONS

METRIC
DISTANCES AND ELEVATIONS SHOWN ON THIS PLAN ARE IN METRES
AND CAN BE CONVERTED TO FEET BY DIVIDING BY 0.3048

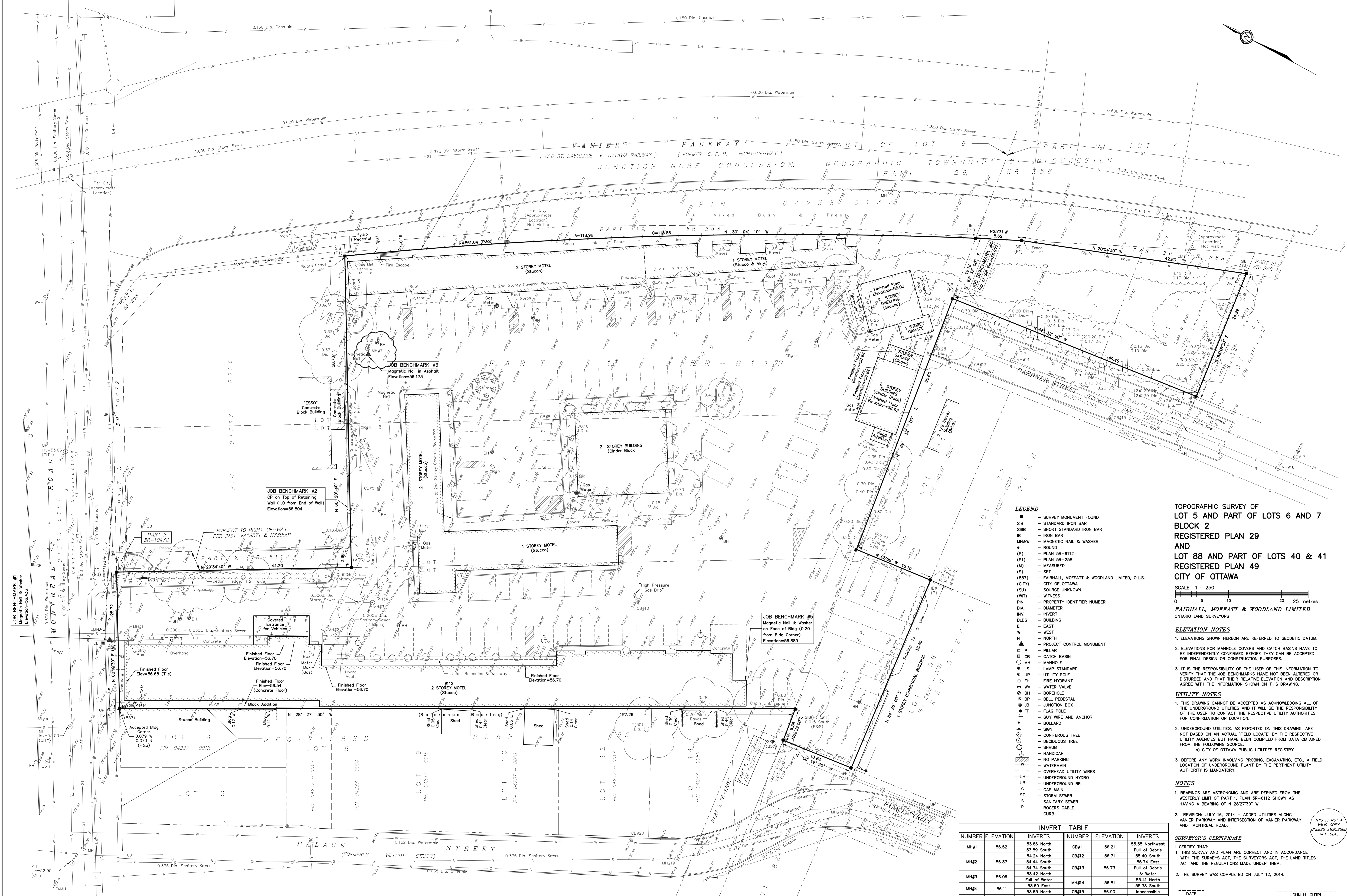

TOPOGRAPHIC SURVEY OF LOT 5 AND PART OF LOTS 6 AND 7 BLOCK 2 REGISTERED PLAN 29 AND LOT 88 AND PART OF LOTS 40 & 41 REGISTERED PLAN 49 CITY OF OTTAWA

SCALE 1 : 250
FAIRHALL, MOFFATT & WOODLAND LIMITED
ONTARIO LAND SURVEYORS

ELEVATION NOTES
1. ELEVATIONS SHOWN HEREON ARE REFERRED TO GEODETIC DATUM.
2. ELEVATIONS FOR MANHOLE COVERS AND CATCH BASINS HAVE TO BE INDEPENDENTLY CONFIRMED BEFORE THEY CAN BE ACCEPTED FOR FINAL DESIGN OR CONSTRUCTION PURPOSES.
3. IT IS THE RESPONSIBILITY OF THE USER OF THIS INFORMATION TO VERIFY THAT THE JOB BENCHMARKS HAVE NOT BEEN ALTERED OR DISTURBED AND THAT THEIR RELATIVE ELEVATION AND DESCRIPTION AGREE WITH THE INFORMATION SHOWN ON THIS DRAWING.

UTILITY NOTES
1. THIS DRAWING CANNOT BE ACCEPTED AS ACKNOWLEDGING ALL OF THE UNDERGROUND UTILITIES AND IT WILL BE THE RESPONSIBILITY OF THE USER TO CONTACT THE RESPECTIVE UTILITY AUTHORITIES FOR CONFIRMATION OR LOCATION.
2. UNDERGROUND UTILITIES, AS REPORTED ON THIS DRAWING, ARE NOT BASED ON AN ACTUAL FIELD LOCATE BY THE RESPECTIVE UTILITY AGENCIES BUT HAVE BEEN COMPILED FROM DATA OBTAINED FROM THE FOLLOWING SOURCE:
a) CITY OF OTTAWA PUBLIC UTILITIES REGISTRY
3. BEFORE ANY WORK INVOLVING PROBING, EXCAVATING, ETC., A FIELD LOCATION OF UNDERGROUND PLANT BY THE PERTINENT UTILITY AUTHORITY IS MANDATORY.

NOTES
1. BEARINGS ARE ASTROMONIC AND ARE DERIVED FROM THE WESTERLY LIMIT OF PART 1, PLAN SR-6112 SHOWN AS HAVING A BEARING OF N 28°27'30" W.
2. REVISION: JULY 16, 2014 - ADDED UTILITIES ALONG VANIER PARKWAY AND INTERSECTION OF VANIER PARKWAY AND MONTREAL ROAD.

SURVEYOR'S CERTIFICATE
I CERTIFY THAT:
1. THIS SURVEY AND PLAN ARE CORRECT AND IN ACCORDANCE WITH THE SURVEYS ACT, THE SURVEYORS ACT, THE LAND TITLES ACT AND THE REGULATIONS MADE UNDER THEM.
2. THE SURVEY WAS COMPLETED ON JULY 12, 2014.

DATE: _____
JOHN H. GUTHRIE
ONTARIO LAND SURVEYOR

Fairhall Moffatt & Woodland
100-600 1887 7TH AVE. S.W. SUITE 200, OTTAWA ONT. K1P 6E6
TEL: (613) 591-2500 FAX: (613) 591-1450
www.fmw.com

JOB NO. T 25600
E 370053, N 5032955
REFERENCE No. 21(a)-49, 15(a)-29
TP256T.DWG (DWG)

- LEGEND**
- SURVEY MONUMENT FOUND
 - SIB — STANDARD IRON BAR
 - SIBB — SHORT STANDARD IRON BAR
 - IB — IRON BAR
 - MNW — MAGNETIC NAIL & WASHER
 - ROUND
 - (P) — PLAN SR-6112
 - (P1) — PLAN SR-258
 - (M) — MEASURED
 - (S) — SET
 - (857) — FAIRHALL, MOFFATT & WOODLAND LIMITED, O.L.S.
 - (CITY) — CITY OF OTTAWA
 - (SU) — SOURCE UNKNOWN
 - (W) — WITNESS
 - PIN — PROPERTY IDENTIFIER NUMBER
 - DIA. — DIAMETER
 - INV. — INVERT
 - BLDG. — BUILDING
 - E — EAST
 - W — WEST
 - N — NORTH
 - ▲ — PROJECT CONTROL MONUMENT
 - — PILLAR
 - CB — CATCH BASIN
 - — MANHOLE
 - LS — LAMP STANDARD
 - UP — UTILITY POLE
 - FH — FIRE HYDRANT
 - WV — WATER VALVE
 - BH — BOREHOLE
 - BP — BELL PEDESTAL
 - JB — JUNCTION BOX
 - FP — FLAG POLE
 - GUY WIRE AND ANCHOR
 - BOLLARD
 - SIGN
 - CONIFEROUS TREE
 - DECIDUOUS TREE
 - SHRUB
 - HANDICAP
 - NO PARKING
 - WATERMAIN
 - OVERHEAD UTILITY WIRES
 - UNDERGROUND HYDRO
 - UNDERGROUND BELL
 - GAS MAIN
 - STORM SEWER
 - SANITARY SEWER
 - ROGERS CABLE
 - CURB

INVERT TABLE

NUMBER	ELEVATION	INVERTS	NUMBER	ELEVATION	INVERTS
MH#1	56.52	53.86 North	CB#11	56.21	55.55 Northwest
		53.89 South			Full of Debris
MH#2	56.37	54.24 North	CB#12	56.71	55.40 South
		54.44 South			55.74 East
		54.34 South	CB#13	56.73	Full of Debris & Water
MH#3	56.06	53.42 North			
		Full of Water	MH#14	56.81	55.41 North
MH#4	56.11	53.69 East			53.69 South
		53.65 North	CB#15	56.90	Inaccessible
CB#5	56.00	Invert Inaccessible	MH#16	57.45	55.13 North
CB#6	56.11	Northwest Inaccessible			55.12 South
		55.01 Southwest	CB#17	57.31	55.87 West
		West Inaccessible			
MH#7	56.22	54.05 East	MH#18	56.70	54.07 North
CB#8	55.80	54.86 North	MH#19	56.50	54.06 South
		54.80 West			53.69 North
CB#9	55.79	Inaccessible			53.90 South
CB#10	55.82	Inaccessible	CB#20	56.33	55.52 West

© COPYRIGHT 2014. REPRODUCTION, ALTERATION OR DISTRIBUTION OF THIS PLAN WITHOUT THE WRITTEN CONSENT OF FAIRHALL, MOFFATT & WOODLAND LIMITED IS PROHIBITED.

APPENDIX

C

PRE-DEVELOPMENT CALCULATIONS

	Stormwater Management Calculations	Project: 112 Montreal Road	No.: 19M-01935-00	
	Pre-Dev Release Rates	By: JW	Date: 5/7/2021	Page: 1
		Checked: MH		

Step 1: Determine Pre-development Flow using Rational Formula

* Runoff Coefficient, C in accordance with City of Ottawa Sewer Design Guidelines (section 8.3.7.3)
 Runoff Coefficient, C = 0.5 -

Rainfall intensity calculated in accordance with City of Ottawa Sewer Design Guidelines (section 5.4.2):

$$i = \left[\frac{A}{(Td + C)^B} \right]$$

Where: A, B, C = regression constants for each return period (defined in section 5.4.2)

i = rainfall intensity (mm/hour)

Td = storm duration (minutes) 180 minutes

Time of Concentration = 20 minutes

Catchment Area = 1.22 ha

Return Period	2	5	10	25	50	100
a =	733.0	998.1	1,174.2	1,402.9	1,569.6	1,735.7
b =	0.810	0.814	0.816	0.819	0.820	0.820
c =	6.199	6.053	6.014	6.018	6.014	6.014
Intensity _{peak} (mm/hr) =	52.0	70.3	82.2	97.3	108.5	120.0
Q _{peak} (L/s) =	88.2	119.0	139.3	164.8	183.8	203.2
Q _{peak} (m ³ /s) =	0.088	0.119	0.139	0.165	0.184	0.203

Return Period = 5 year

Q = 119.0 L/s Pre-development flow rate

Conclusion:

The 5-year pre-development flow rate for a 20 minute Tc governs the 100-year maximum post-development release rate and is 120.5 L/s.

Filepath:

L:\Water Resources\Projects\Pre-2017\1013081-000 - 112 Montreal Road\20210401 Updated Site Plan\210428_JW\112 Montreal Rd Calcs.xlsx\IDF Calcs

APPENDIX

D

PROPOSED SITE
DRAWINGS

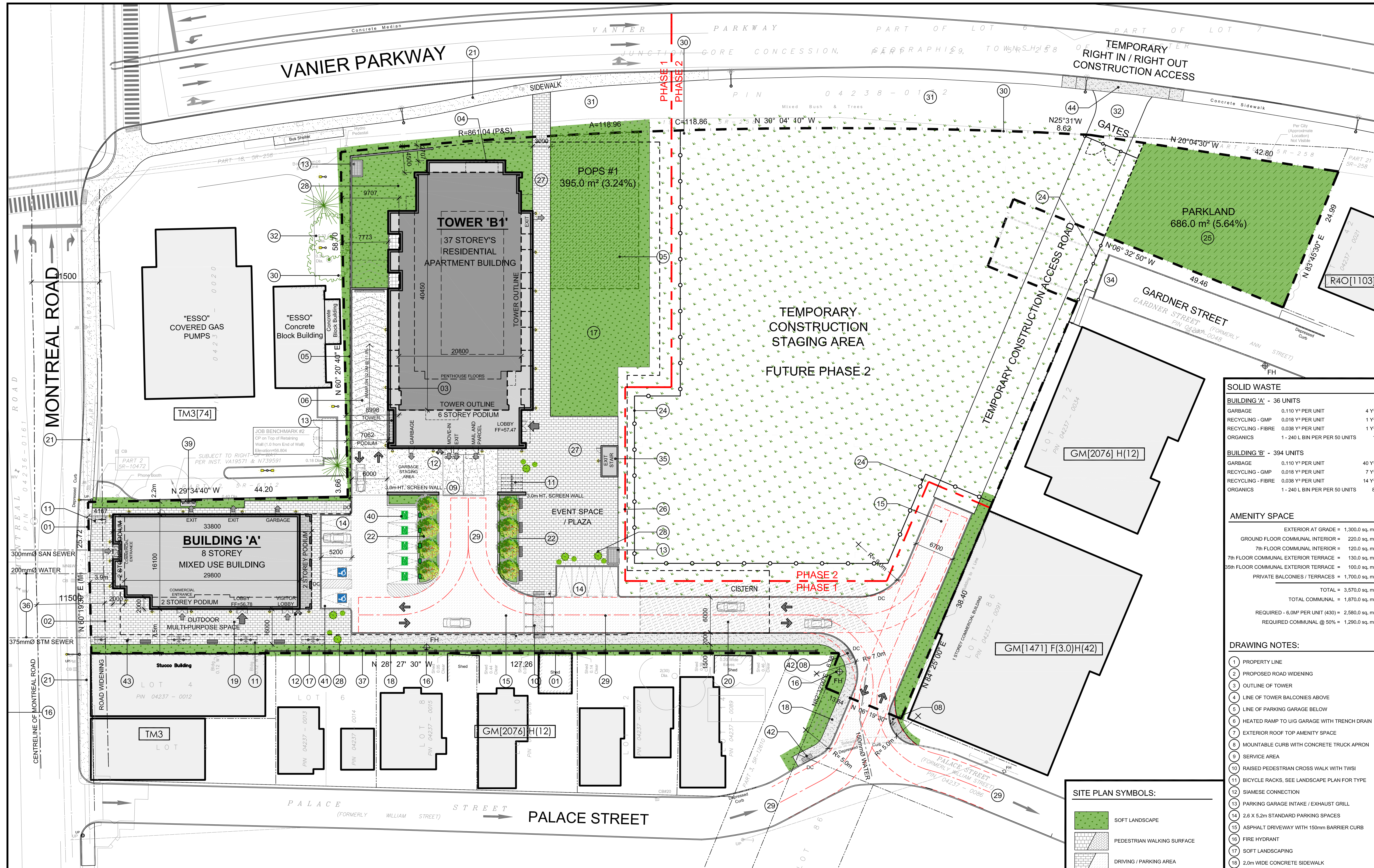

1 SITE PLAN - PHASE 1
 SP-1
 SCALE = 1 : 300
 0m 5 10 20 30
 SCALE 1:300

PROJECT DEVELOPER Manor Park Management 231 Britanya Drive, Suite D Ottawa, ON Canada, K1K 0R8 E-Mail: isa@manorparkcap.com	PROJECT MANAGER Renfro Land Management 371A Richmond Rd. Unit 2, Ottawa, ON K2L 1Y3 Tel: (613) 883-6124 E-Mail: davidrenfro@outlook.com	LEGAL DESCRIPTION TOPOGRAPHIC SURVEY OF LOT 5 AND PART OF LOTS 6 AND 7 BLOCK 2 REGISTERED PLAN 29 AND LOT 88 AND PART OF LOTS 40 & 41 REGISTERED PLAN 49 CITY OF OTTAWA
SURVEYOR FAIRHALL, MOFFATT & WOODLAND LIMITED 100-600 TERRY FOX DRIVE KANATA, ONTARIO K2L 4B6 Tel: (613) 591-2580 Fax: (613) 591-1495 Email:	GEOTECHNICAL ENGINEER paterson group 154 Colonnade Road South Ottawa, Ontario, K2E 7J5 Tel: 613.226-7381 Email: DGilbert@Patersongroup.ca	URBAN PLANNER FoTenn Consultants Inc. 396 Cooper Street, Unit 300 Ottawa, ON Canada, K2P 2H7 Tel: (613) 730-5709 Fax: (613) 730-1136 E-Mail: posen@fotenn.com
CIVIL ENGINEER WSP 300 - 2611 Queensview Drive Ottawa, ON K2B 8K2 Tel: +1 613-829-2800 Email: Ishaque.Jafferjee@wsp.com	TRANSPORTATION ENGINEER CGH Transportation Inc. 6 Plaza Court Ottawa, ON K2H 7W1 Tel: (343) 999-9117 Cell: (613) 697-3797 Email: andrew.harte@cgtransportation.com	LANDSCAPE DESIGNER LEVSTEK CONSULTANTS 5871 Hugh Crescent Ottawa, ON Canada, K0a 2w0 Tel: (613) 826-0518 E-Mail: rievstek@iarocquelevstek.com

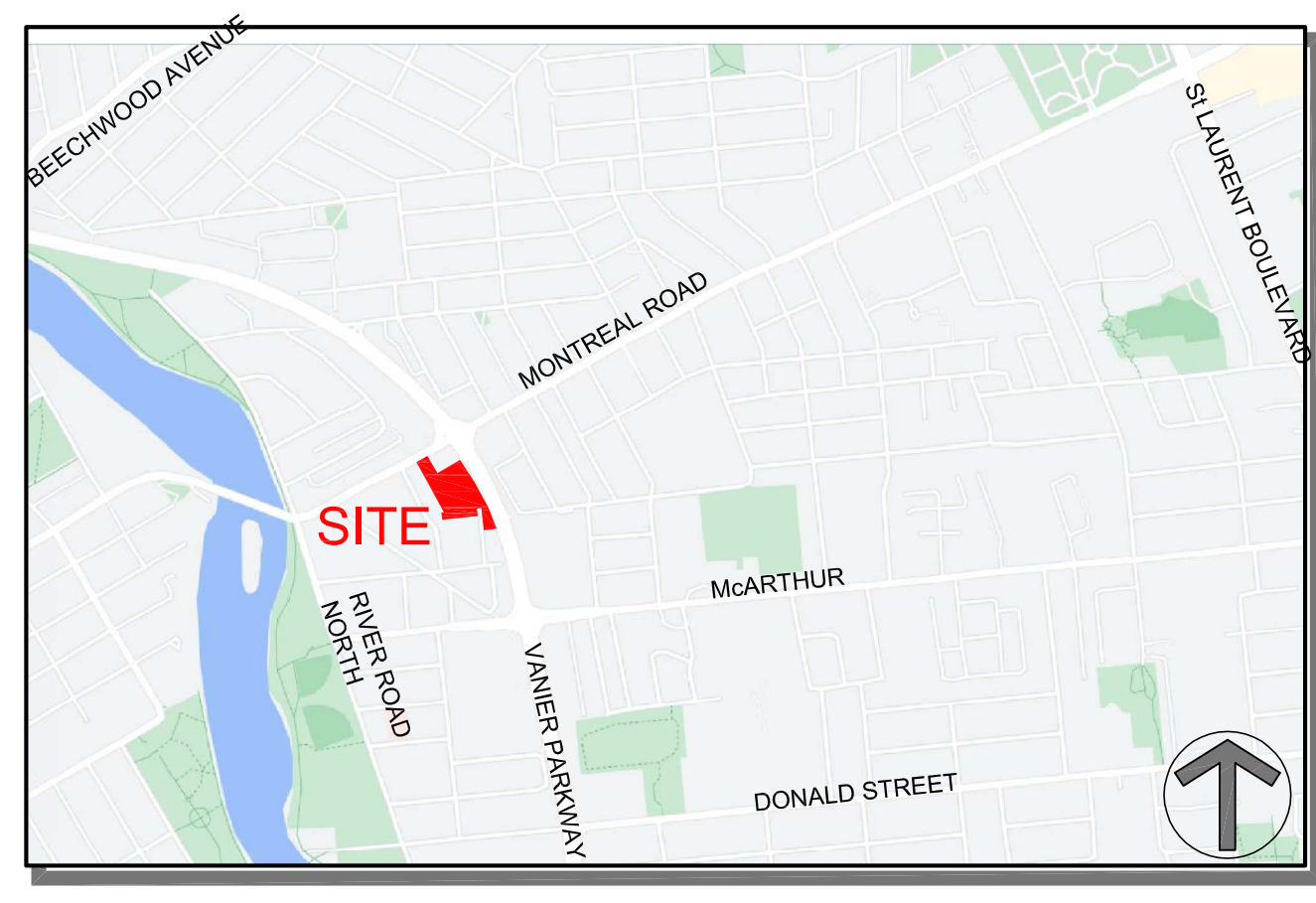

SITE PLAN SYMBOLS:

	SOFT LANDSCAPE
	PEDESTRIAN WALKING SURFACE
	DRIVING / PARKING AREA
	CONCRETE SIDEWALK
	EXISTING CITY CONCRETE SIDEWALK
	CONCRETE DRIVEWAY / RAMP
	UNDEVELOPED AREA
	PARKLAND DEDICATION
	PROPERTY LINE
	FENCE LINE
	BIKE RACK
	ENTRANCE / EXIT DOOR
	COMMERCIAL / EXIT DOOR
	FIRE HYDRANT
	VEHICULAR DIRECTION
	EXISTING TREE TO REMAIN
	SIAMESE CONNECTION

NOTE:
 SEE LANDSCAPE FOR ALL SURFACE MATERIAL AND PATTERN

SOLID WASTE

BUILDING 'A' - 36 UNITS

GARBAGE	0.110 Y ² PER UNIT	4 Y ²
RECYCLING - GMP	0.018 Y ² PER UNIT	1 Y ²
RECYCLING - FIBRE	0.038 Y ² PER UNIT	1 Y ²
ORGANICS	1 - 240 L BIN PER PER 50 UNITS	1

BUILDING 'B' - 394 UNITS

GARBAGE	0.110 Y ² PER UNIT	40 Y ²
RECYCLING - GMP	0.018 Y ² PER UNIT	7 Y ²
RECYCLING - FIBRE	0.038 Y ² PER UNIT	14 Y ²
ORGANICS	1 - 240 L BIN PER PER 50 UNITS	8

AMENITY SPACE

EXTERIOR AT GRADE	= 1,300.0 sq. m.
GROUND FLOOR COMMUNAL INTERIOR	= 220.0 sq. m.
7th FLOOR COMMUNAL INTERIOR	= 120.0 sq. m.
7th FLOOR COMMUNAL EXTERIOR TERRACE	= 130.0 sq. m.
35th FLOOR COMMUNAL EXTERIOR TERRACE	= 100.0 sq. m.
PRIVATE BALCONIES / TERRACES	= 1,700.0 sq. m.
TOTAL	= 3,570.0 sq. m.
TOTAL COMMUNAL	= 1,870.0 sq. m.
REQUIRED - 6.0M ² PER UNIT (430)	= 2,580.0 sq. m.
REQUIRED COMMUNAL @ 50%	= 1,290.0 sq. m.

- DRAWING NOTES:**
- PROPERTY LINE
 - PROPOSED ROAD WIDENING
 - OUTLINE OF TOWER
 - LINE OF TOWER BALCONIES ABOVE
 - LINE OF PARKING GARAGE BELOW
 - HEATED RAMP TO U/G GARAGE WITH TRENCH DRAIN
 - MOUNTABLE CURB WITH CONCRETE TRUCK APRON
 - SERVICE AREA
 - RAISED PEDESTRIAN CROSS WALK WITH TWSI
 - BIKE RACKS, SEE LANDSCAPE PLAN FOR TYPE
 - SIAMESE CONNECTION
 - PARKING GARAGE INTAKE / EXHAUST GRILL
 - 2.6 X 5.2m STANDARD PARKING SPACES
 - ASPHALT DRIVEWAY WITH 150mm BARRIER CURB
 - FIRE HYDRANT
 - SOFT LANDSCAPING
 - 2.0m WIDE CONCRETE SIDEWALK
 - EXTERIOR PATIO (COMMERCIAL / COMMUNAL)
 - BELOW GRADE CISTERN
 - EXISTING CITY SIDEWALK INSTALL SUMMER OF 2021
 - RAISED PLANTER
 - EXISTING CHAIN LINK FENCE
 - CONSTRUCTION STAGING ACCESS
 - EXISTING SOFT LANDSCAPED BOULEVARD
 - 6.0M WIDE FIRE ROUTE
 - EXISTING CHAIN LINK FENCE
 - EXISTING TREE TO REMAIN PROTECT AS REQUIRED
 - ALTER EXISTING STREET AS SHOWN
 - PARKING GARAGE EXIT STAIR
 - PROPOSED BUILDING SERVICES, SEE CIVIL
 - 2.1m HT. SOLID WOOD FENCE
 - SEASONAL PLANTERS
 - GAS PRESSURE RELEASE STATION
 - ELECTRIC VEHICLE CHARGING STATION
 - ACCESSIBLE PARKING SPACE
 - DEPRESSED CURB - TWSI AS SHOWN
 - CYCLE REPAIR STATION
 - DEPRESSED CURB AND CONTINUOUS SIDEWALK TO CITY STANDARDS, SEE CIVIL

PROJECT INFORMATION

ZONING	TM(2363) S365-h
SITE AREA	12,165.45 sq. m. 130,346 sq. ft.
PHASE 1 AREA	6,150.19 sq. m. 66,200 sq. ft.
PHASE 2 AREA	6,015.26 sq. m. 64,748 sq. ft.

REQUIRED

BUILDING HEIGHT - BLDG A	8 Storeys / 29.0m
BUILDING HEIGHT - BLDG B1	37 Storeys / 116.0m
BUILDING HEIGHT - BLDG B2	28 Storeys / 89.0m
BUILDING HEIGHT - BLDG B3	16 Storeys / 53.0m
BUILDING SETBACKS	as per Schedule S365-h
RESIDENTIAL PARKING - AREA 'Y'	0.5 per unit
VISITOR PARKING - AREA 'Y'	0.1 per unit
COMMERCIAL PARKING - RESTAURANT	not required
BIKE PARKING - COMMERCIAL	1 per 250m ² of G.F.A.
AMENITY SPACE	6.0 m ² per unit

NOTATION SYMBOLS:

- INDICATES DRAWING NOTES, LISTED ON EACH SHEET.
- INDICATES ASSEMBLY TYPE; REFER TO TYPICAL ASSEMBLIES SCHEDULE.
- INDICATES WINDOW TYPE; REFER TO WINDOW ELEVATIONS AND DETAILS ON A300 SERIES.
- INDICATES DOOR TYPE; REFER TO DOOR SCHEDULE AND DETAILS ON A300 SERIES.
- TITLE
- DETAIL REFERENCE PAGE
- DETAIL CROSS REFERENCE PAGE

PROJECT STATISTICS - PHASE 1

BUILDING 'A'	STAGE 1 CONSTRUCTION	0.0 sq. m.
PARKING LEVEL		000 sq. ft.
GROUND FLOOR		234.6 sq. m.
2nd FLOOR		4,158 sq. m.
3rd - 8th FLOOR		1,866.2 sq. m.
MECHANICAL LEVEL		20,088 sq. ft.
TOTAL AREA		2,510.8 sq. m.
COMMERCIAL AREA		234.6 sq. m.
UNIT COUNT		36
UNIT PARKING	0.5 PER UNIT AFTER 12 UNITS	12
VISITOR PARKING	0.1 PER UNIT AFTER 12 UNITS	2
BIKE PARKING	0.5 PER UNIT	18
COMMERCIAL BIKE	1.0 PER 250m ² OF G.F.A.	1

BUILDING 'B' STAGE 2 CONSTRUCTION

PARKING LEVEL	0.0 sq. m.	
GROUND FLOOR	257.2 sq. m.	
2nd FLOOR	2,768 sq. ft.	
3rd - 6th FLOOR	4,449.1 sq. m.	
7th FLOOR	524.4 sq. m.	
8th - 34th FLOOR TOWER	17,551.15 sq. m.	
35th - 37th FLOOR	1,364.56 sq. m.	
MECHANICAL LEVEL	0.0 sq. m.	
TOTAL AREA	24,146.4 sq. m.	
TOWER FOOTPRINT	807.2 sq. m.	
UNIT COUNT	394	
UNIT PARKING	0.5 PER UNIT AFTER 12 UNITS	191
VISITOR PARKING	0.1 PER UNIT AFTER 12 UNITS	30
BIKE PARKING	0.5 PER UNIT	197

REVISIONS:

ISSUED FOR SPC 1st COMMENT RESPONSE	2023 03 15
ISSUED FOR SPC 1st COMMENT REVIEW	2023 03 14
ISSUED FOR LDRP SPC SUBMISSION	2023 01 19
ISSUED FOR CONSULTANT COORDINATION	2023 01 10
ISSUED FOR SPC APPLICATION - PHASE 1	2022 09 13
ISSUED FOR CONSULTANT COORDINATION	2022 06 22
ISSUED FOR CONSULTANT COORDINATION	2022 02 21

UNIT MIX

TOWNHOUSE UNIT	0
ONE BEDROOM	291
TWO BEDROOM UNIT	107
THREE BEDROOM UNIT	32
TOTAL UNITS	430

CAR PARKING

REQUIRED BY ZONING BY-LAW

RESIDENCE	-0.5 PER UNIT (AFTER 12 UNITS)	203
VISITOR	-0.1 PER DWELLING UNIT (AFTER 12 UNITS) (MAX 30)	32
COMMERCIAL RETAIL	*NON REQUIRED	0
TOTAL		235

PROVIDED

RESIDENCE	-0.59 PER UNIT	358
VISITOR	-0.07 PER UNIT	32
COMMERCIAL RETAIL		0
TOTAL		390

LOCATION
 SURFACE
 BELOW GRADE - 3 LEVELS

CLIENT:
2705460 Ontario Inc.

ARCHITECT:
rla / architecture
 roderick lahey architect inc.
 56 beech street, ottawa, ontario K1S 3J6
 t. 613.724.9932 f. 613.724.1209 rlaarchitecture.ca

BICYCLE PARKING

REQUIRED

RESIDENCE	-0.5 PER UNIT (430 UNITS)	215
COMMERCIAL RETAIL	-1.0 PER 250m ² OF G.F.A.	1
TOTAL		216

PROVIDED

EXTERIOR	26
U/G PARKING LEVEL P1 FOR - PHASE 1	410
U/G PARKING LEVEL P1 FOR - PHASE 2	465
TOTAL	901

LOT COVERAGE

UNDEVELOPED AREA	= 43.81%	5,329.2 sq. m.
PARK LAND SPACE	= 5.64%	686.0 sq. m.
PAVED SURFACE	= 13.64%	1,660.0 sq. m.
BUILDING FOOTPRINT	= 13.13%	1,597.5 sq. m.
LANDSCAPE OPEN SPACE	= 23.78%	2,892.69 sq. m.
TOTAL	= 100.00%	12,165.45 sq. m.

PROJECT TITLE:
112 MONTREAL ROAD

SHEET TITLE:
SITE PLAN PHASE 1

DRAWN: RV
 CHECKED: R.V.
 SCALE: 1:300
 SHEET No.: SP-1
 PROJECT No.: 2026

APPENDIX

E

CATCHMENT PLAN



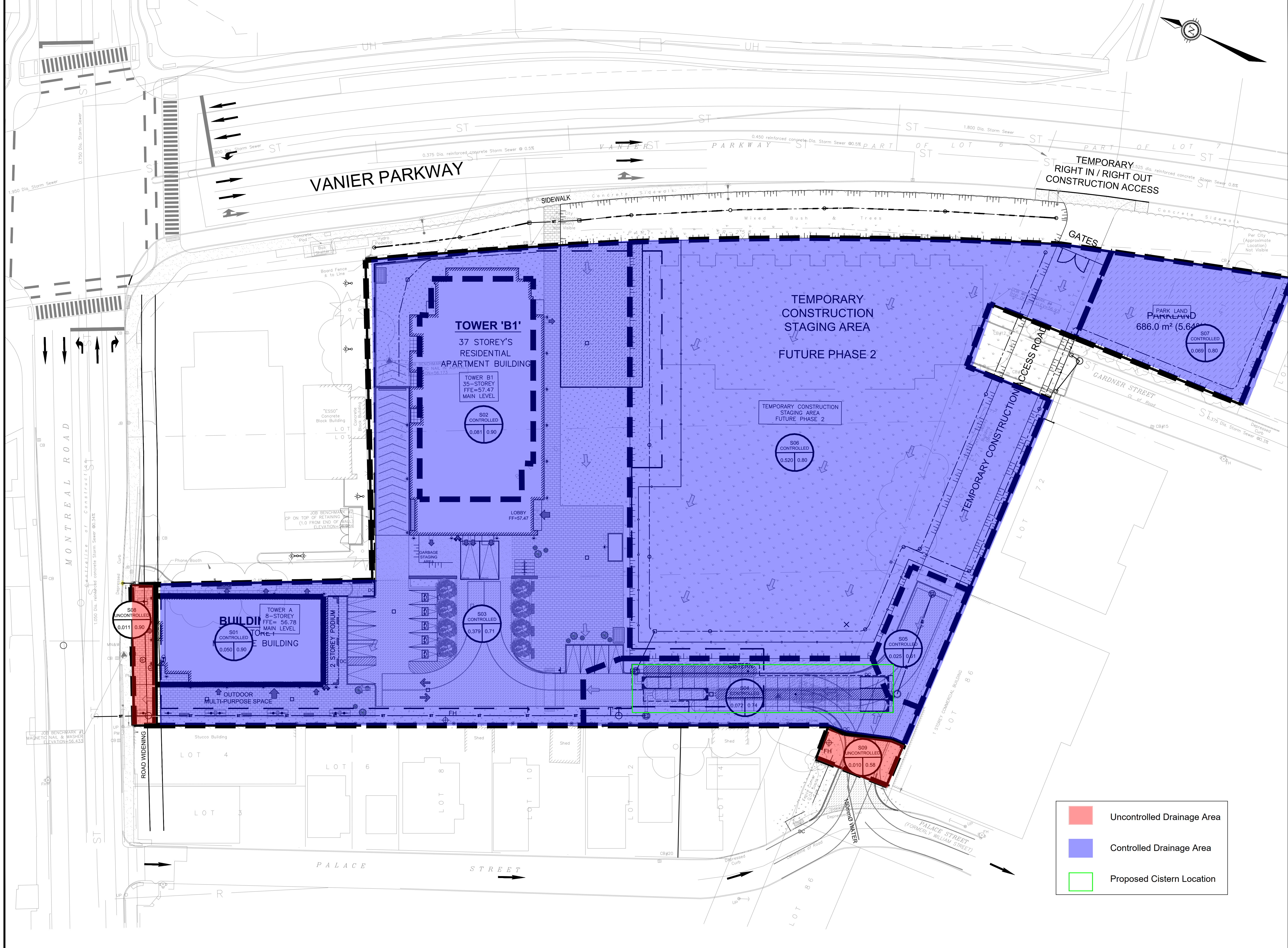

GENERAL NOTES:
 THE ENGINEER WAIVES ANY AND ALL RESPONSIBILITY AND LIABILITY FOR PROBLEMS WHICH ARISE FROM FAILURE TO FOLLOW THE PLANS, SPECIFICATIONS AND THE DESIGN INTENT THEY CONVEY, OR FOR PROBLEMS WHICH ARISE FROM OTHERS FAILURE TO OBTAIN AND/OR FOLLOW THE ENGINEERS GUIDANCE WITH RESPECT TO ANY ERRORS, OMISSIONS, INCONSISTENCIES, AMBIGUITIES OR CONFLICTS WHICH ARE ALLEGED.
 CONTRACTOR TO VERIFY ALL DIMENSIONS AND NOTIFY THE ENGINEER OF ANY DISCREPANCIES BEFORE WORK COMMENCES. DO NOT SCALE DRAWINGS.

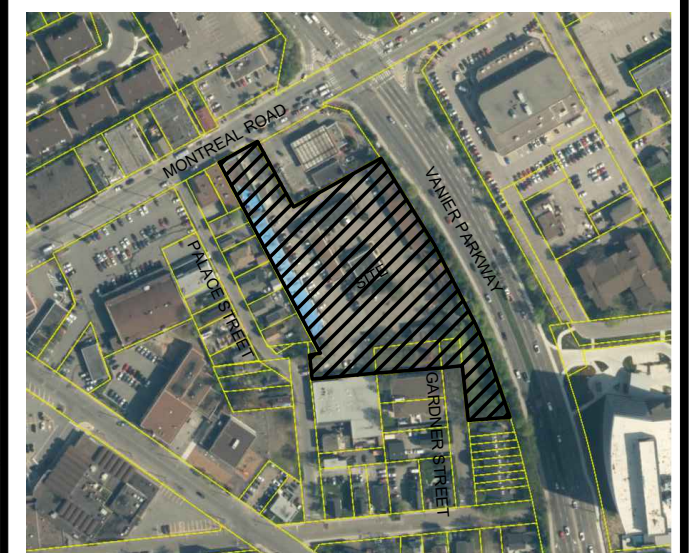

KEY PLAN
(N.T.S.)

SUBJECT TO APPROVAL

BENCH MARK No.1 ELEVATION=56.43
 ELEVATIONS SHOWN ON THIS PLAN ARE RELATED TO GEODETIC DATUM AND ARE DERIVED FROM THE WESTERLY LIMIT OF PART 1, PLAN 5R-6112 SHOWN AS HAVING A BEARING OF N28°27'30"W.
 TOWNSHIP: CITY OF OTTAWA

No.	REVISIONS	BY	DATE
01	ISSUED FOR SPA	D.Y.	2022-09-13

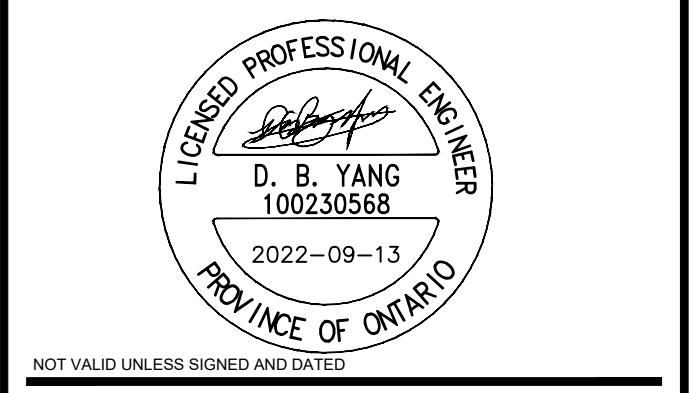
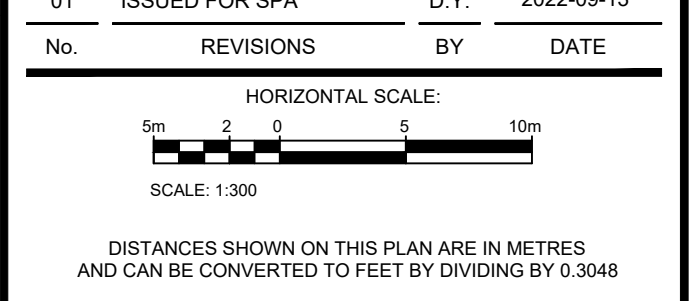

CLIENT
 2705460 ONTARIO INC.
 C/O ANAND AGGARWAL
 MANOR PARK MANAGEMENT
 231 BRITTANY DRIVE, SUITE D
 OTTAWA, ON K1K 0R8



ANNIS, O'SULLIVAN, VOLLEBECK
 Ontario Land Surveyors
 14 CONCORDE GATE, SUITE 400, NEPEAN, ONTARIO, K2E 7S8
 TEL: (613) 727-0850 FAX: (613) 727-1079

DESIGNED BY: D.Y. **DRAWN BY:** J.T. **APPROVED BY:** D.Y.

PROJECT
 112 MONTREAL ROAD
 RESIDENTIAL DEVELOPMENT

DRAWING TITLE
 STORM DRAINAGE
 AREA PLAN

PROJECT NO. 19M-01935-00 **DRAWING NO.** C04

- Uncontrolled Drainage Area
- Controlled Drainage Area
- Proposed Cistern Location

FILENAME: V:\19\19M-01935-00 - 112 Montreal Road - Site Plan\Drawings\storm\19M-01935-00_C_DRAWING.rvt
 PLOTDATE: Mar 09, 2023 11:58am CA:070482Z

APPENDIX

F

SUPPORTING
DOCUMENTS

APPENDIX

F-1 *HYDRO-BRAKE RATING CURVE*

Technical Specification

Control Point	Head (m)	Flow (l/s)
Primary Design	1.430	112.000
Flush-Flo™	0.624	111.480
Kick-Flo®	1.106	98.784
Mean Flow		90.219

Hydro-Brake® Optimum Flow Control including:

- 5 mm grade 304L stainless steel
- Integral stainless steel pivoting by-pass door allowing clear line of sight through to outlet, c/w stainless steel operating rope outlet, c/w stainless steel operating rope
- Beed blasted finish to maximise corrosion resistance
- Stainless steel fixings
- Rubber gasket to seal outlet
- Indicative Weight: 147 kg



hydro-int.com/patents

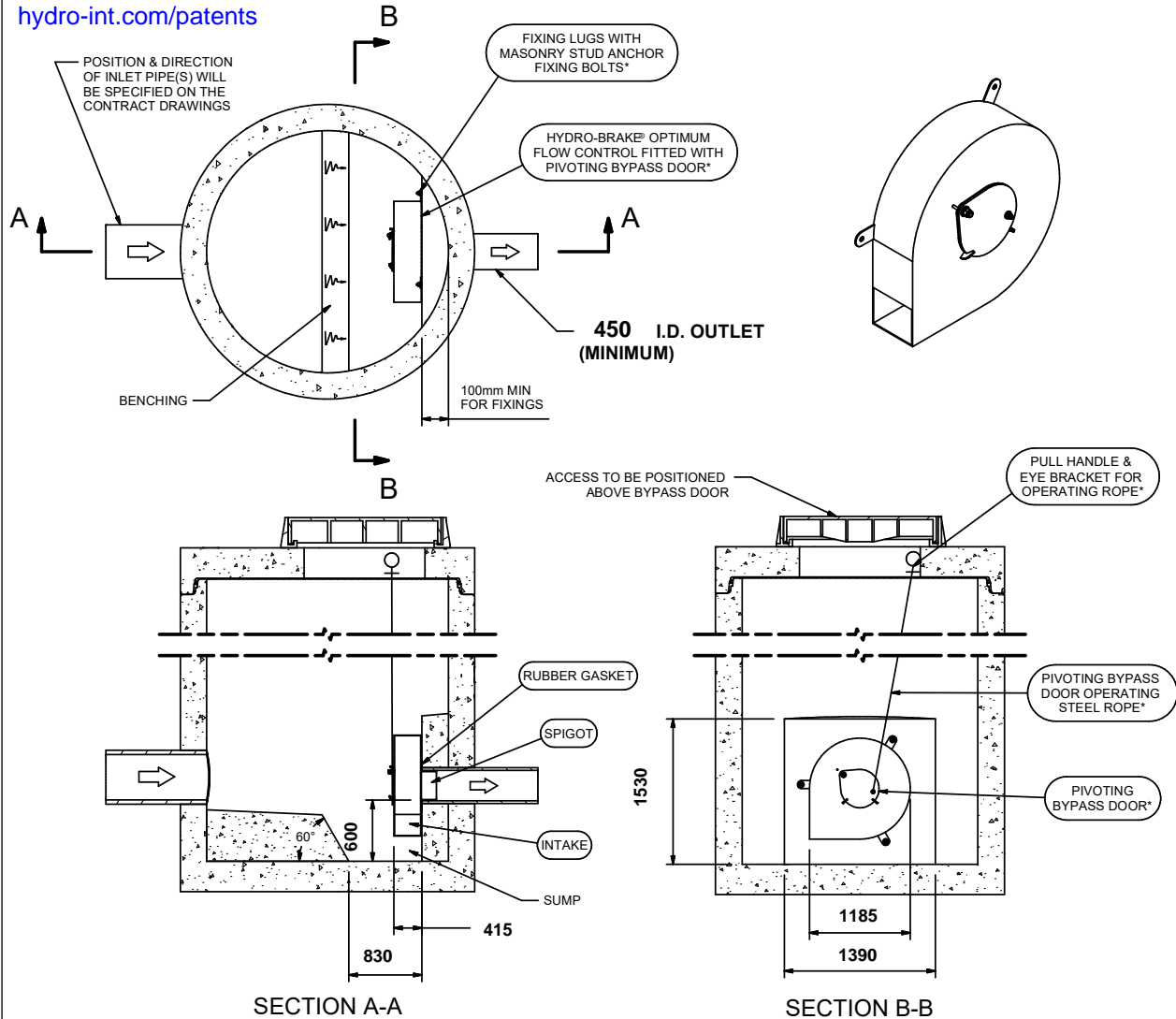

IMPORTANT: ○ LIMIT OF HYDRO INTERNATIONAL SUPPLY
 THE DEVICE WILL BE HANDED TO SUIT SITE CONDITIONS
 FOR SITE SPECIFIC DETAILS AND MINIMUM CHAMBER SIZE REFER TO HYDRO INTERNATIONAL
 ALL CIVIL AND INSTALLATION WORK BY OTHERS
 * WHERE SUPPLIED
 HYDRO-BRAKE® FLOW CONTROL & HYDRO-BRAKE® OPTIMUM FLOW CONTROL ARE REGISTERED TRADEMARKS FOR FLOW
 CONTROLS DESIGNED AND MANUFACTURED EXCLUSIVELY BY HYDRO INTERNATIONAL

THIS DESIGN LAYOUT IS FOR ILLUSTRATIVE PURPOSES ONLY. NOT TO SCALE.

DESIGN ADVICE



The head/flow characteristics of this SHE-0408-1120-1430-1120 Hydro-Brake® Optimum Flow Control are unique. Dynamic hydraulic modelling evaluates the full head/flow characteristic curve.
The use of any other flow control will invalidate any design based on this data and could constitute a flood risk.

Hydro
 International

DATE	3/3/2023 12:50 PM	SHE-0408-1120-1430-1120 Hydro-Brake® Optimum
SITE	112 Montreal Rd	
DESIGNER	Kathryn Kerker	
REF	CBMH02	

Technical Specification

Control Point	Head (m)	Flow (l/s)
Primary Design	1.430	112.000
Flush-Flo	0.624	111.480
Kick-Flo®	1.106	98.784
Mean Flow		90.219



PT/329/0412

hydro-int.com/patents

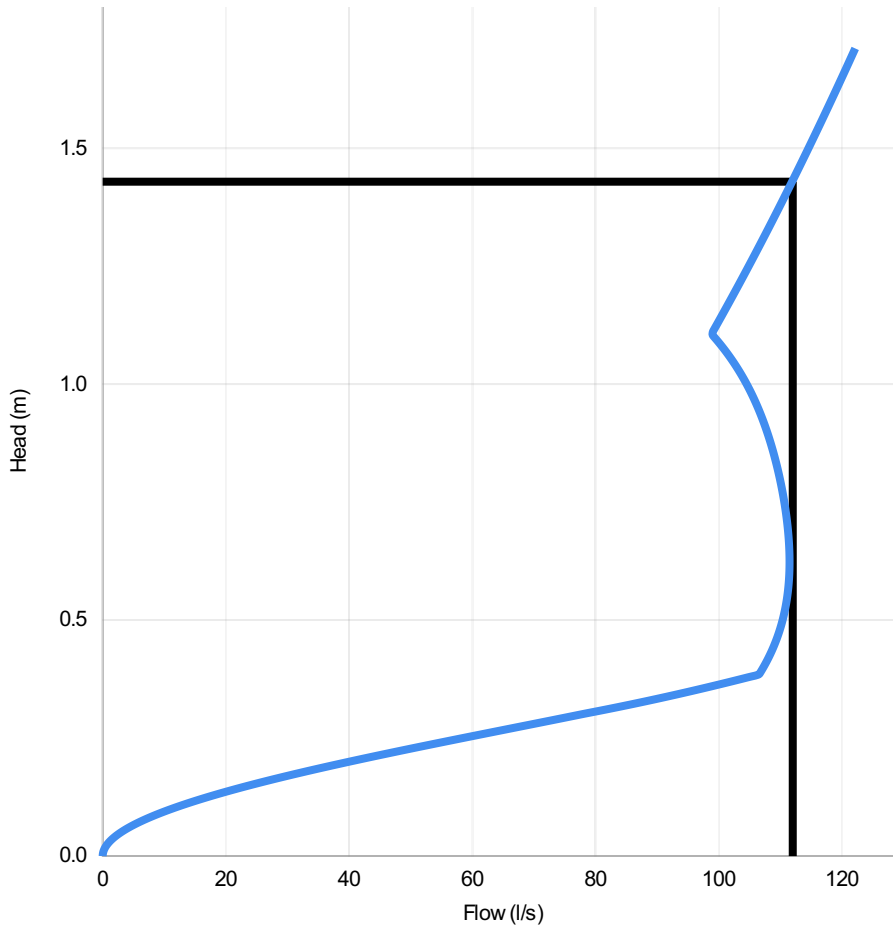

Head (m)	Flow (l/s)
0.000	0.000
0.049	2.831
0.099	10.844
0.148	23.211
0.197	38.977
0.247	57.008
0.296	75.890
0.345	93.970
0.394	106.976
0.444	108.885
0.493	110.201
0.542	111.016
0.592	111.412
0.641	111.462
0.690	111.229
0.740	110.761
0.789	110.087
0.838	109.217
0.888	108.131
0.937	106.782
0.986	105.096
1.036	102.965
1.085	100.260
1.134	99.982
1.183	102.067
1.233	104.109
1.282	106.109
1.331	108.071
1.381	109.997
1.430	111.888

DESIGN ADVICE

The head/flow characteristics of this SHE-0408-1120-1430-1120 Hydro-Brake Optimum® Flow Control are unique. Dynamic hydraulic modeling evaluates the full head/flow characteristic curve.



The use of any other flow control will invalidate any design based on this data and could constitute a flood risk.



DATE	3/3/2023 12:50 PM
Site	112 Montreal Rd
DESIGNER	Kathryn Kerker
Ref	CBMH02

SHE-0408-1120-1430-1120
Hydro-Brake Optimum®

APPENDIX

F-2 *WATTS ACUTROL* *ROOF DRAIN*



Adjustable Accutrol Weir

Tag: _____

Adjustable Flow Control for Roof Drains

ADJUSTABLE ACCUTROL (for Large Sump Roof Drains only)

For more flexibility in controlling flow with heads deeper than 2", Watts Drainage offers the Adjustable Accutrol. The Adjustable Accutrol Weir is designed with a single parabolic opening that can be covered to restrict flow above 2" of head to less than 5 gpm per inch, up to 6" of head. To adjust the flow rate for depths over 2" of head, set the slot in the adjustable upper cone according to the flow rate required. Refer to Table 1 below.
 Note: Flow rates are directly proportional to the amount of weir opening that is exposed.

EXAMPLE:

For example, if the adjustable upper cone is set to cover 1/2 of the weir opening, flow rates above 2" of head will be restricted to 2-1/2 gpm per inch of head.

Therefore, at 3" of head, the flow rate through the Accutrol Weir that has 1/2 the slot exposed will be:
 [5 gpm (per inch of head) x 2 inches of head] + 2-1/2 gpm (for the third inch of head) = 12-1/2 gpm.

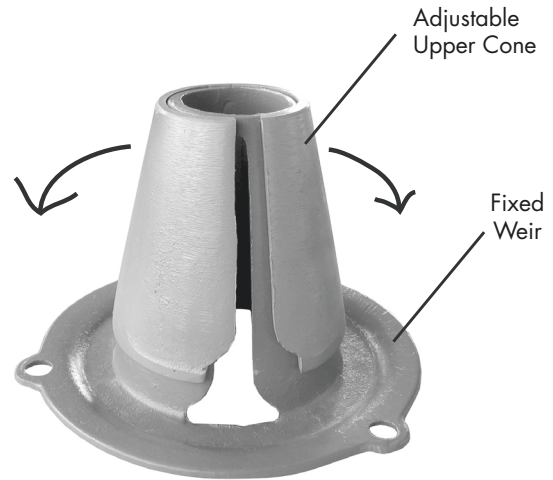
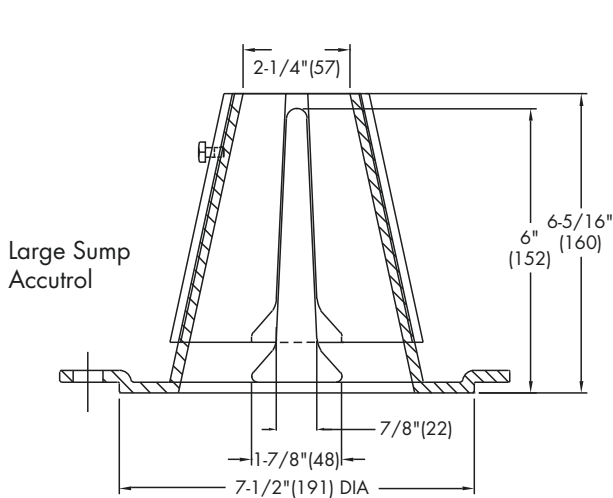

1/2 Weir Opening Exposed Shown Above

TABLE 1. Adjustable Accutrol Flow Rate Settings

Weir Opening Exposed	1"	2"	3"	4"	5"	6"
	Flow Rate (gallons per minute)					
Fully Exposed	5	10	15	20	25	30
3/4	5	10	13.75	17.5	21.25	25
1/2	5	10	12.5	15	17.5	20
1/4	5	10	11.25	12.5	13.75	15
Closed	5	5	5	5	5	5

Job Name _____
 Job Location _____
 Engineer _____

Contractor _____
 Contractor's P.O. No. _____
 Representative _____

Watts product specifications in U.S. customary units and metric are approximate and are provided for reference only. For precise measurements, please contact Watts Technical Service. Watts reserves the right to change or modify product design, construction, specifications, or materials without prior notice and without incurring any obligation to make such changes and modifications on Watts products previously or subsequently sold.

USA: Tel: (800) 338-2581 • Fax: (828) 248-3929 • Watts.com
 Canada: Tel: (905) 332-4090 • Fax: (905) 332-7068 • Watts.ca
 Latin America: Tel: (52) 81-1001-8600 • Fax: (52) 81-8000-7091 • Watts.com



APPENDIX

F-3 *STORMTECH CHAMBER*

PROJECT INFORMATION	
ENGINEERED PRODUCT MANAGER:	HAIDER NASRULLAH 647-850-9417 HAIDER.NASRULLAH@ADSPIPE.COM
ADS SALES REP:	HASSAN ELMI 416-985-9757 HASSAN.ELMI@ADSPIPE.COM
PROJECT NO:	S334625
ONTARIO SITE COORDINATOR:	RYAN RUBENSTEIN 519-710-3687 RYAN.RUBENSTEIN@ADS-PIPE.COM



112 MONTREAL ROAD

OTTAWA, ON.

MC-3500 STORMTECH CHAMBER SPECIFICATIONS

- CHAMBERS SHALL BE STORMTECH MC-3500.
- CHAMBERS SHALL BE ARCH-SHAPED AND SHALL BE MANUFACTURED FROM VIRGIN, IMPACT-MODIFIED POLYPROPYLENE COPOLYMERS.
- CHAMBERS SHALL BE CERTIFIED TO CSA B184, "POLYMERIC SUB-SURFACE STORMWATER MANAGEMENT STRUCTURES", AND MEET THE REQUIREMENTS OF ASTM F2418, "STANDARD SPECIFICATION FOR POLYPROPYLENE (PP) CORRUGATED WALL STORMWATER COLLECTION CHAMBERS" CHAMBER CLASSIFICATION 45x76 DESIGNATION SS.
- CHAMBER ROWS SHALL PROVIDE CONTINUOUS, UNOBSTRUCTED INTERNAL SPACE WITH NO INTERNAL SUPPORTS THAT WOULD IMPEDE FLOW OR LIMIT ACCESS FOR INSPECTION.
- THE STRUCTURAL DESIGN OF THE CHAMBERS, THE STRUCTURAL BACKFILL, AND THE INSTALLATION REQUIREMENTS SHALL ENSURE THAT THE LOAD FACTORS SPECIFIED IN THE AASHTO LRFD BRIDGE DESIGN SPECIFICATIONS, SECTION 12.12, ARE MET FOR: 1) LONG-DURATION DEAD LOADS AND 2) SHORT-DURATION LIVE LOADS, BASED ON THE CSA S6 CL-625 TRUCK AND THE AASHTO DESIGN TRUCK WITH CONSIDERATION FOR IMPACT AND MULTIPLE VEHICLE PRESENCES.
- CHAMBERS SHALL BE DESIGNED, TESTED AND ALLOWABLE LOAD CONFIGURATIONS DETERMINED IN ACCORDANCE WITH ASTM F2787, "STANDARD PRACTICE FOR STRUCTURAL DESIGN OF THERMOPLASTIC CORRUGATED WALL STORMWATER COLLECTION CHAMBERS". LOAD CONFIGURATIONS SHALL INCLUDE: 1) INSTANTANEOUS (<1 MIN) AASHTO DESIGN TRUCK LIVE LOAD ON MINIMUM COVER 2) MAXIMUM PERMANENT (75-YR) COVER LOAD AND 3) ALLOWABLE COVER WITH PARKED (1-WEEK) AASHTO DESIGN TRUCK.
- REQUIREMENTS FOR HANDLING AND INSTALLATION:
 - TO MAINTAIN THE WIDTH OF CHAMBERS DURING SHIPPING AND HANDLING, CHAMBERS SHALL HAVE INTEGRAL, INTERLOCKING STACKING LUGS.
 - TO ENSURE A SECURE JOINT DURING INSTALLATION AND BACKFILL, THE HEIGHT OF THE CHAMBER JOINT SHALL NOT BE LESS THAN 75 mm (3").
 - TO ENSURE THE INTEGRITY OF THE ARCH SHAPE DURING INSTALLATION, a) THE ARCH STIFFNESS CONSTANT SHALL BE GREATER THAN OR EQUAL TO 450 LBS/FT/%. THE ASC IS DEFINED IN SECTION 6.2.8 OF ASTM F2418. AND b) TO RESIST CHAMBER DEFORMATION DURING INSTALLATION AT ELEVATED TEMPERATURES (ABOVE 23° C / 73° F), CHAMBERS SHALL BE PRODUCED FROM REFLECTIVE GOLD OR YELLOW COLORS.
- ONLY CHAMBERS THAT ARE APPROVED BY THE SITE DESIGN ENGINEER WILL BE ALLOWED. UPON REQUEST BY THE SITE DESIGN ENGINEER OR OWNER, THE CHAMBER MANUFACTURER SHALL SUBMIT A STRUCTURAL EVALUATION FOR APPROVAL BEFORE DELIVERING CHAMBERS TO THE PROJECT SITE AS FOLLOWS:
 - THE STRUCTURAL EVALUATION SHALL BE SEALED BY A REGISTERED PROFESSIONAL ENGINEER.
 - THE STRUCTURAL EVALUATION SHALL DEMONSTRATE THAT THE SAFETY FACTORS ARE GREATER THAN OR EQUAL TO 1.95 FOR DEAD LOAD AND 1.75 FOR LIVE LOAD, THE MINIMUM REQUIRED BY ASTM F2787 AND BY SECTIONS 3 AND 12.12 OF THE AASHTO LRFD BRIDGE DESIGN SPECIFICATIONS FOR THERMOPLASTIC PIPE.
 - THE TEST DERIVED CREEP MODULUS AS SPECIFIED IN ASTM F2418 SHALL BE USED FOR PERMANENT DEAD LOAD DESIGN EXCEPT THAT IT SHALL BE THE 75-YEAR MODULUS USED FOR DESIGN.
- CHAMBERS AND END CAPS SHALL BE PRODUCED AT AN ISO 9001 CERTIFIED MANUFACTURING FACILITY.

IMPORTANT - NOTES FOR THE BIDDING AND INSTALLATION OF MC-3500 CHAMBER SYSTEM

- STORMTECH MC-3500 CHAMBERS SHALL NOT BE INSTALLED UNTIL THE MANUFACTURER'S REPRESENTATIVE HAS COMPLETED A PRE-CONSTRUCTION MEETING WITH THE INSTALLERS.
- STORMTECH MC-3500 CHAMBERS SHALL BE INSTALLED IN ACCORDANCE WITH THE "STORMTECH MC-3500/MC-4500 CONSTRUCTION GUIDE".
- CHAMBERS ARE NOT TO BE BACKFILLED WITH A DOZER OR AN EXCAVATOR SITUATED OVER THE CHAMBERS. STORMTECH RECOMMENDS 3 BACKFILL METHODS:
 - STONESHOOTER LOCATED OFF THE CHAMBER BED.
 - BACKFILL AS ROWS ARE BUILT USING AN EXCAVATOR ON THE FOUNDATION STONE OR SUBGRADE.
 - BACKFILL FROM OUTSIDE THE EXCAVATION USING A LONG BOOM HOE OR EXCAVATOR.
- THE FOUNDATION STONE SHALL BE LEVELED AND COMPACTED PRIOR TO PLACING CHAMBERS.
- JOINTS BETWEEN CHAMBERS SHALL BE PROPERLY SEATED PRIOR TO PLACING STONE.
- MAINTAIN MINIMUM - 150 mm (6") SPACING BETWEEN THE CHAMBER ROWS.
- INLET AND OUTLET MANIFOLDS MUST BE INSERTED A MINIMUM OF 300 mm (12") INTO CHAMBER END CAPS.
- EMBEDMENT STONE SURROUNDING CHAMBERS MUST BE A CLEAN, CRUSHED, ANGULAR STONE WELL GRADED BETWEEN ¾" AND 2" (20-50 mm).
- STONE MUST BE PLACED ON THE TOP CENTER OF THE CHAMBER TO ANCHOR THE CHAMBERS IN PLACE AND PRESERVE ROW SPACING.
- THE CONTRACTOR MUST REPORT ANY DISCREPANCIES WITH CHAMBER FOUNDATION MATERIALS BEARING CAPACITIES TO THE SITE DESIGN ENGINEER.
- ADS RECOMMENDS THE USE OF "FLEXSTORM CATCH IT" INSERTS DURING CONSTRUCTION FOR ALL INLETS TO PROTECT THE SUBSURFACE STORMWATER MANAGEMENT SYSTEM FROM CONSTRUCTION SITE RUNOFF.

NOTES FOR CONSTRUCTION EQUIPMENT

- STORMTECH MC-3500 CHAMBERS SHALL BE INSTALLED IN ACCORDANCE WITH THE "STORMTECH MC-3500/MC-4500 CONSTRUCTION GUIDE".
- THE USE OF EQUIPMENT OVER MC-3500 CHAMBERS IS LIMITED:
 - NO EQUIPMENT IS ALLOWED ON BARE CHAMBERS.
 - NO RUBBER TIRE LOADER, DUMP TRUCK, OR EXCAVATORS ARE ALLOWED UNTIL PROPER FILL DEPTHS ARE REACHED IN ACCORDANCE WITH THE "STORMTECH MC-3500/MC-4500 CONSTRUCTION GUIDE".
 - WEIGHT LIMITS FOR CONSTRUCTION EQUIPMENT CAN BE FOUND IN THE "STORMTECH MC-3500/MC-4500 CONSTRUCTION GUIDE".
- FULL 900 mm (36") OF STABILIZED COVER MATERIALS OVER THE CHAMBERS IS REQUIRED FOR DUMP TRUCK TRAVEL OR DUMPING.

USE OF A DOZER TO PUSH EMBEDMENT STONE BETWEEN THE ROWS OF CHAMBERS MAY CAUSE DAMAGE TO CHAMBERS AND IS NOT AN ACCEPTABLE BACKFILL METHOD. ANY CHAMBERS DAMAGED BY USING THE "DUMP AND PUSH" METHOD ARE NOT COVERED UNDER THE STORMTECH STANDARD WARRANTY.

CONTACT STORMTECH AT 1-888-892-2694 WITH ANY QUESTIONS ON INSTALLATION REQUIREMENTS OR WEIGHT LIMITS FOR CONSTRUCTION EQUIPMENT.

PROPOSED LAYOUT

63	STORMTECH MC-3500 CHAMBERS
10	STORMTECH MC-3500 END CAPS
305	STONE ABOVE (mm)
229	STONE BELOW (mm)
40	% STONE VOID
310.0	INSTALLED SYSTEM VOLUME (m³) ABOVE ELEVATION 54.268 (PERIMETER STONE INCLUDED)
348.4	SYSTEM AREA (m²)
113.7	SYSTEM PERIMETER (m)

PROPOSED ELEVATIONS

57.809	MAXIMUM ALLOWABLE GRADE (TOP OF PAVEMENT/UNPAVED):
55.981	MINIMUM ALLOWABLE GRADE (UNPAVED WITH TRAFFIC):
55.828	MINIMUM ALLOWABLE GRADE (UNPAVED NO TRAFFIC):
55.828	MINIMUM ALLOWABLE GRADE (BASE OF FLEXIBLE PAVEMENT):
55.828	MINIMUM ALLOWABLE GRADE (TOP OF RIGID PAVEMENT):
55.676	TOP OF STONE:
55.371	TOP OF MC-3500 CHAMBER:
54.898	300 mm TOP CONNECTION INVERT:
54.822	375 mm TOP MANIFOLD INVERT:
54.583	300 mm CUSTOM MANIFOLD INVERT:
54.280	600 mm ISOLATOR ROW INVERT:
54.273	450 mm ISOLATOR ROW INVERT:
54.268	375 mm BOTTOM MANIFOLD INVERT:
54.228	BOTTOM OF MC-3500 CHAMBER:
53.999	BOTTOM OF STONE:

NOTES

- MANIFOLD SIZE TO BE DETERMINED BY SITE DESIGN ENGINEER. SEE TECHNICAL NOTE 6.32 FOR MANIFOLD SIZING GUIDANCE.
- DUE TO THE ADAPTATION OF THIS CHAMBER SYSTEM TO SPECIFIC SITE AND DESIGN CONSTRAINTS, IT MAY BE NECESSARY TO CUT AND COUPLE ADDITIONAL PIPE TO STANDARD MANIFOLD COMPONENTS IN THE FIELD.
- THE SITE DESIGN ENGINEER MUST REVIEW ELEVATIONS AND IF NECESSARY ADJUST GRADING TO ENSURE THE CHAMBER COVER REQUIREMENTS ARE MET.
- THIS CHAMBER SYSTEM WAS DESIGNED WITHOUT SITE-SPECIFIC INFORMATION ON SOIL CONDITIONS OR BEARING CAPACITY. THE SITE DESIGN ENGINEER IS RESPONSIBLE FOR DETERMINING THE SUITABILITY OF THE SOIL AND PROVIDING THE BEARING CAPACITY OF THE INSITU SOILS. THE BASE STONE DEPTH MAY BE INCREASED OR DECREASED ONCE THIS INFORMATION IS PROVIDED.
- THE SITE DESIGN ENGINEER MUST REVIEW THE PROXIMITY OF THE CHAMBERS TO THE SLOPE AND CONSIDER EFFECTS OF POSSIBLE SATURATED SOILS ON THE SLOPE'S INTEGRITY.
- THE SITE DESIGN ENGINEER MUST REVIEW THE PROXIMITY OF THE CHAMBERS TO THE BUILDING/STRUCTURE. NO FOUNDATION LOADS SHALL BE TRANSMITTED TO THE CHAMBERS. THE SITE DESIGN ENGINEER MUST CONSIDER EFFECTS OF POSSIBLE SATURATED SOILS ON BEARING CAPACITY OF SOILS AND SEEPAGE INTO BASEMENTS.

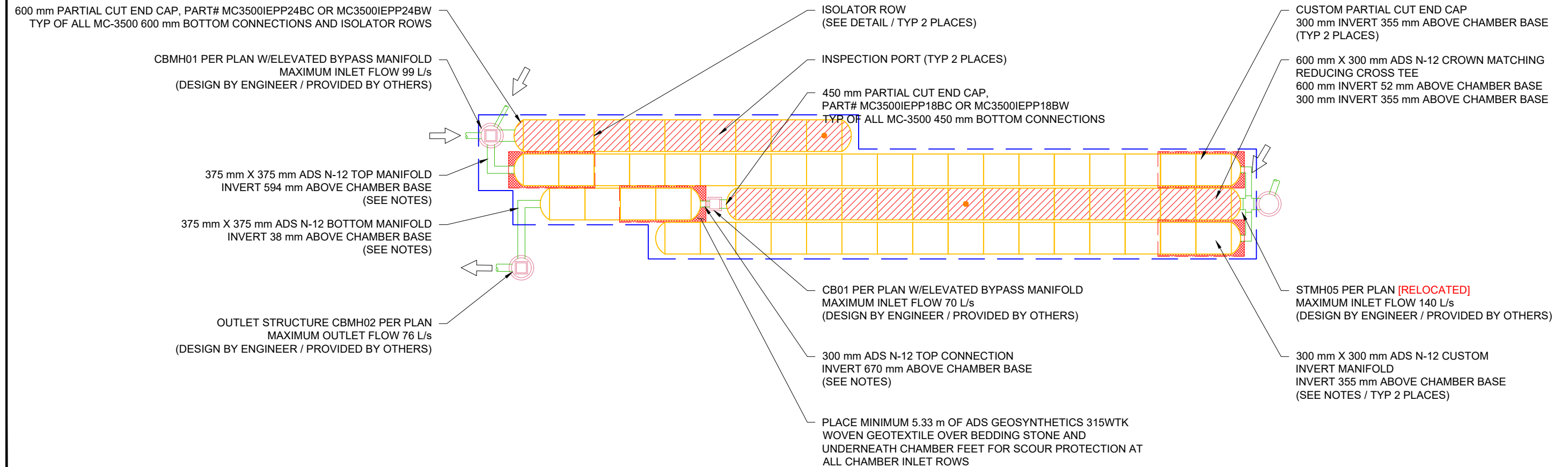

112 MONTREAL ROAD

OTTAWA, ON.

DATE: 01/25/23 DRAWN: JR

PROJECT #: S334625 CHECKED: RWD

DATE	DRWN	CHKD	DESCRIPTION
2/23/23	RCT	RCT	VOLUME ABOVE OUTLET/ADD CHAMBERS
02/03/23	RCT	RCT	REVISED PER NEW PLAN

StormTech®
Chamber System

888-892-2694 | WWW.STORMTECH.COM

4640 TRUEMAN BLVD
HILLIARD, OH 43026

SCALE = 1 : 250

THIS DRAWING HAS BEEN PREPARED BASED ON INFORMATION PROVIDED TO ADS UNDER THE DIRECTION OF THE SITE DESIGN ENGINEER OR OTHER PROJECT REPRESENTATIVE. THE SITE DESIGN ENGINEER SHALL REVIEW THIS DRAWING PRIOR TO CONSTRUCTION. IT IS THE ULTIMATE RESPONSIBILITY OF THE SITE DESIGN ENGINEER TO ENSURE THAT THE PRODUCT(S) DEPICTED AND ALL ASSOCIATED DETAILS MEET ALL APPLICABLE LAWS, REGULATIONS, AND PROJECT REQUIREMENTS.

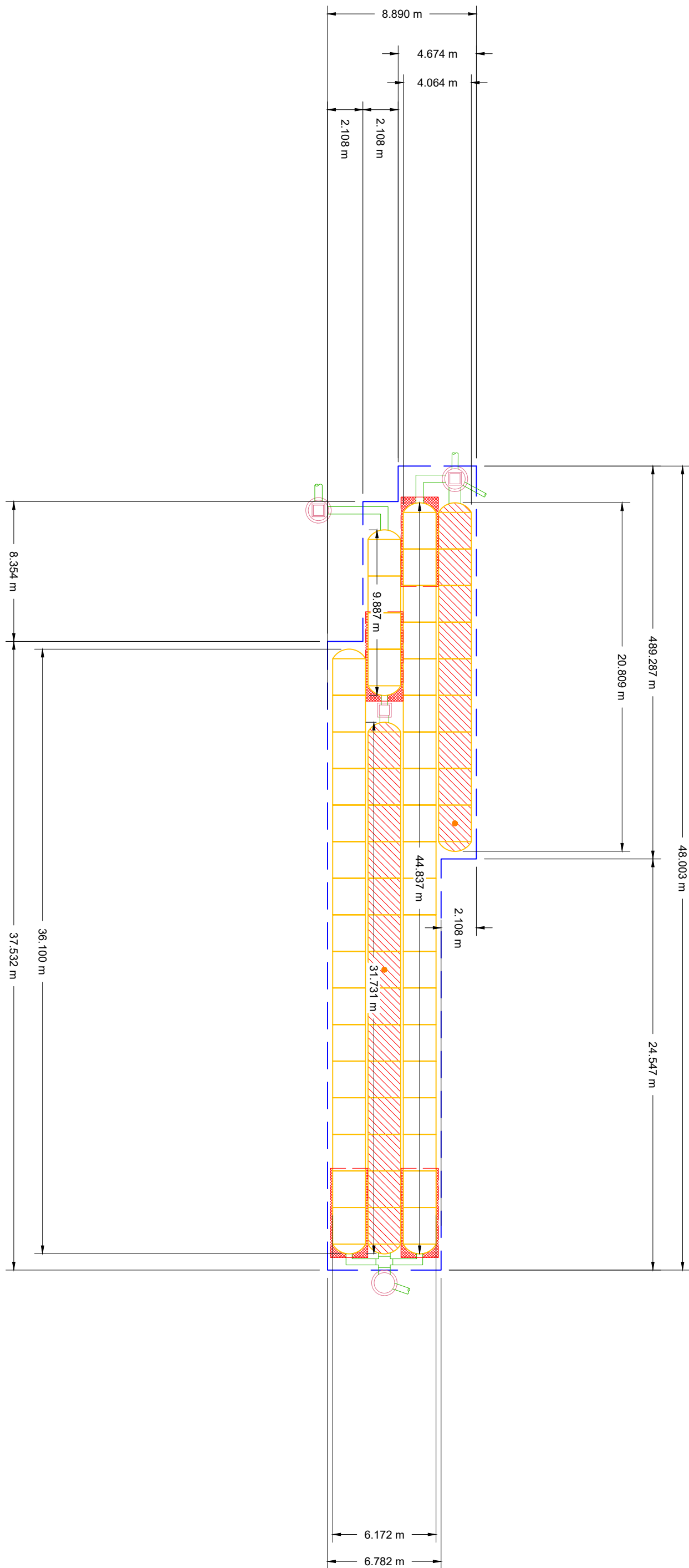

3 OF 6 SHEET

ADS 4640 TRUEMAN BLVD
HILLIARD, OH 43026

StormTech®
Chamber System

888-892-2694 | WWW.STORMTECH.COM

SCALE = 1 : 250

DATE	DRWN	CHKD	DESCRIPTION
2/23/23	RCT	RCT	VOLUME ABOVE OUTLET/ADD CHAMBERS
02/03/23	RCT	RCT	REVISED PER NEW PLAN

112 MONTREAL ROAD	
OTTAWA, ON.	
DATE: 01/25/23	DRAWN: JR
PROJECT #: S334625	CHECKED: RWD

THIS DRAWING HAS BEEN PREPARED BASED ON INFORMATION PROVIDED TO ADS UNDER THE DIRECTION OF THE SITE DESIGN ENGINEER OR OTHER PROJECT REPRESENTATIVE. THE SITE DESIGN ENGINEER SHALL REVIEW THIS DRAWING PRIOR TO CONSTRUCTION. IT IS THE ULTIMATE RESPONSIBILITY OF THE SITE DESIGN ENGINEER TO ENSURE THAT THE PRODUCT(S) DEPICTED AND ALL ASSOCIATED DETAILS MEET ALL APPLICABLE LAWS, REGULATIONS, AND PROJECT REQUIREMENTS.

ACCEPTABLE FILL MATERIALS: STORMTECH MC-3500 CHAMBER SYSTEMS

MATERIAL LOCATION	DESCRIPTION	AASHTO MATERIAL CLASSIFICATIONS	COMPACTION / DENSITY REQUIREMENT
D	FINAL FILL: FILL MATERIAL FOR LAYER 'D' STARTS FROM THE TOP OF THE 'C' LAYER TO THE BOTTOM OF FLEXIBLE PAVEMENT OR UNPAVED FINISHED GRADE ABOVE. NOTE THAT PAVEMENT SUBBASE MAY BE PART OF THE 'D' LAYER	N/A	PREPARE PER SITE DESIGN ENGINEER'S PLANS. PAVED INSTALLATIONS MAY HAVE STRINGENT MATERIAL AND PREPARATION REQUIREMENTS.
C	INITIAL FILL: FILL MATERIAL FOR LAYER 'C' STARTS FROM THE TOP OF THE EMBEDMENT STONE ('B' LAYER) TO 24" (600 mm) ABOVE THE TOP OF THE CHAMBER. NOTE THAT PAVEMENT SUBBASE MAY BE A PART OF THE 'C' LAYER.	AASHTO M145 ¹ A-1, A-2-4, A-3 OR AASHTO M43 ¹ 3, 357, 4, 467, 5, 56, 57, 6, 67, 68, 7, 78, 8, 89, 9, 10	BEGIN COMPACTIONS AFTER 24" (600 mm) OF MATERIAL OVER THE CHAMBERS IS REACHED. COMPACT ADDITIONAL LAYERS IN 12" (300 mm) MAX LIFTS TO A MIN. 95% PROCTOR DENSITY FOR WELL GRADED MATERIAL AND 95% RELATIVE DENSITY FOR PROCESSED AGGREGATE MATERIALS.
B	EMBEDMENT STONE: FILL SURROUNDING THE CHAMBERS FROM THE FOUNDATION STONE ('A' LAYER) TO THE 'C' LAYER ABOVE.	AASHTO M43 ¹ 3, 4	NO COMPACTION REQUIRED.
A	FOUNDATION STONE: FILL BELOW CHAMBERS FROM THE SUBGRADE UP TO THE FOOT (BOTTOM) OF THE CHAMBER.	AASHTO M43 ¹ 3, 4	PLATE COMPACT OR ROLL TO ACHIEVE A FLAT SURFACE. ^{2,3}

PLEASE NOTE:

- THE LISTED AASHTO DESIGNATIONS ARE FOR GRADATIONS ONLY. THE STONE MUST ALSO BE CLEAN, CRUSHED, ANGULAR. FOR EXAMPLE, A SPECIFICATION FOR #4 STONE WOULD STATE: "CLEAN, CRUSHED, ANGULAR NO. 4 (AASHTO M43) STONE".
- STORMTECH COMPACTION REQUIREMENTS ARE MET FOR 'A' LOCATION MATERIALS WHEN PLACED AND COMPACTED IN 9" (230 mm) (MAX) LIFTS USING TWO FULL COVERAGES WITH A VIBRATORY COMPACTOR.
- WHERE INFILTRATION SURFACES MAY BE COMPROMISED BY COMPACTION, FOR STANDARD DESIGN LOAD CONDITIONS, A FLAT SURFACE MAY BE ACHIEVED BY RAKING OR DRAGGING WITHOUT COMPACTION EQUIPMENT. FOR SPECIAL LOAD DESIGNS, CONTACT STORMTECH FOR COMPACTION REQUIREMENTS.
- ONCE LAYER 'C' IS PLACED, ANY SOIL/MATERIAL CAN BE PLACED IN LAYER 'D' UP TO THE FINISHED GRADE. MOST PAVEMENT SUBBASE SOILS CAN BE USED TO REPLACE THE MATERIAL REQUIREMENTS OF LAYER 'C' OR 'D' AT THE SITE DESIGN ENGINEER'S DISCRETION.

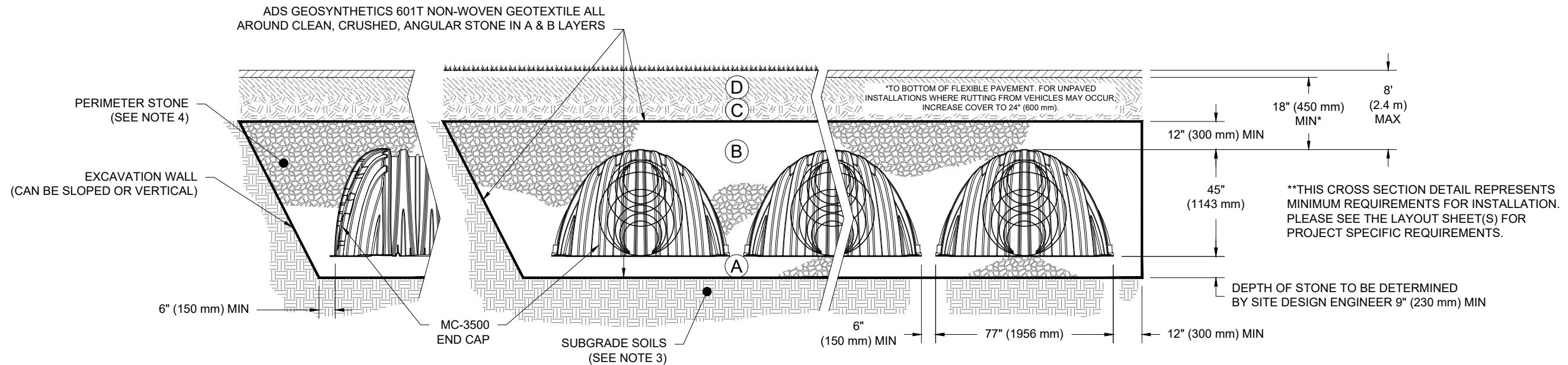

NOTES:

- CHAMBERS SHALL MEET THE REQUIREMENTS OF ASTM F2418, "STANDARD SPECIFICATION FOR POLYPROPYLENE (PP) CORRUGATED WALL STORMWATER COLLECTION CHAMBERS" CHAMBER CLASSIFICATION 45x76 DESIGNATION SS.
- MC-3500 CHAMBERS SHALL BE DESIGNED IN ACCORDANCE WITH ASTM F2787 "STANDARD PRACTICE FOR STRUCTURAL DESIGN OF THERMOPLASTIC CORRUGATED WALL STORMWATER COLLECTION CHAMBERS".
- THE SITE DESIGN ENGINEER IS RESPONSIBLE FOR ASSESSING THE BEARING RESISTANCE (ALLOWABLE BEARING CAPACITY) OF THE SUBGRADE SOILS AND THE DEPTH OF FOUNDATION STONE WITH CONSIDERATION FOR THE RANGE OF EXPECTED SOIL MOISTURE CONDITIONS.
- PERIMETER STONE MUST BE EXTENDED HORIZONTALLY TO THE EXCAVATION WALL FOR BOTH VERTICAL AND SLOPED EXCAVATION WALLS.
- REQUIREMENTS FOR HANDLING AND INSTALLATION:
 - TO MAINTAIN THE WIDTH OF CHAMBERS DURING SHIPPING AND HANDLING, CHAMBERS SHALL HAVE INTEGRAL, INTERLOCKING STACKING LUGS.
 - TO ENSURE A SECURE JOINT DURING INSTALLATION AND BACKFILL, THE HEIGHT OF THE CHAMBER JOINT SHALL NOT BE LESS THAN 3".
 - TO ENSURE THE INTEGRITY OF THE ARCH SHAPE DURING INSTALLATION, a) THE ARCH STIFFNESS CONSTANT AS DEFINED IN SECTION 6.2.8 OF ASTM F2418 SHALL BE GREATER THAN OR EQUAL TO 500 LBS/FT/%. AND b) TO RESIST CHAMBER DEFORMATION DURING INSTALLATION AT ELEVATED TEMPERATURES (ABOVE 73° F / 23° C), CHAMBERS SHALL BE PRODUCED FROM REFLECTIVE GOLD OR YELLOW COLORS.

112 MONTREAL ROAD

OTTAWA, ON.

DATE: 01/25/23 DRAWN: JR

PROJECT #: S334625 CHECKED: RWD

DATE	DESCRIPTION
2/23/23	RCT VOLUME ABOVE OUTLET/ADD CHAMBERS
02/03/23	RCT REVISED PER NEW PLAN
	DRWN CHKD

StormTech®
Chamber System

888-892-2694 | WWW.STORMTECH.COM

4640 TRUEMAN BLVD
HILLIARD, OH 43026



THIS DRAWING HAS BEEN PREPARED BASED ON INFORMATION PROVIDED TO ADS UNDER THE DIRECTION OF THE SITE DESIGN ENGINEER OR OTHER PROJECT REPRESENTATIVE. THE SITE DESIGN ENGINEER SHALL REVIEW THIS DRAWING PRIOR TO CONSTRUCTION. IT IS THE ULTIMATE RESPONSIBILITY OF THE SITE DESIGN ENGINEER TO ENSURE THAT THE PRODUCT(S) DEPICTED AND ALL ASSOCIATED DETAILS MEET ALL APPLICABLE LAWS, REGULATIONS, AND PROJECT REQUIREMENTS.

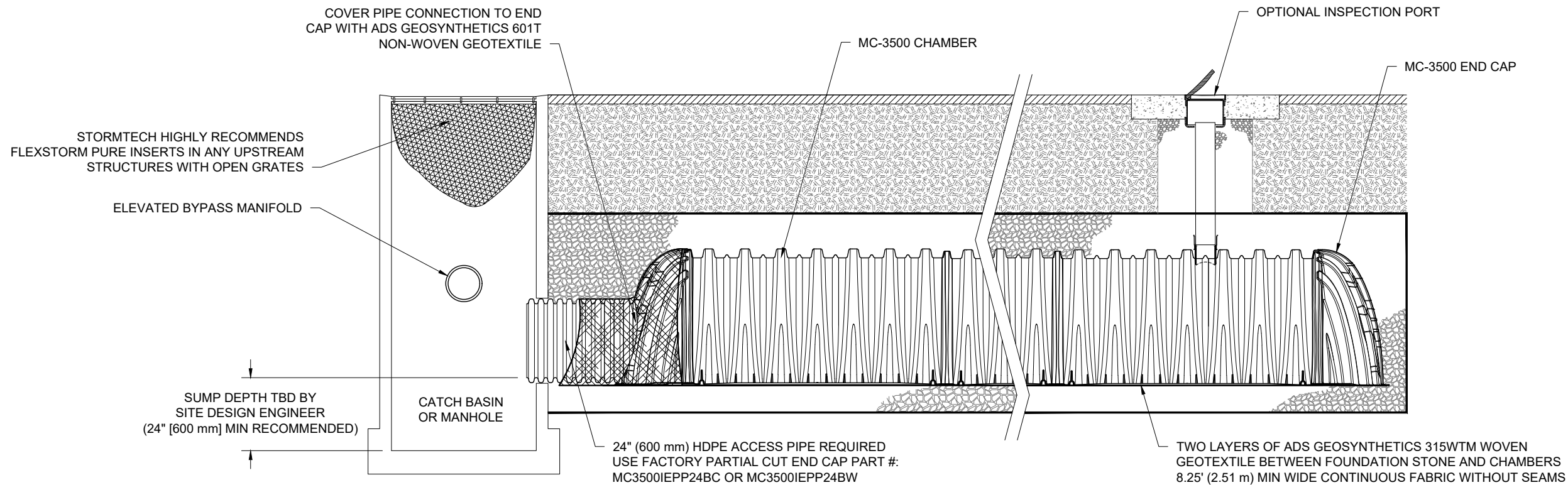

MC-3500 ISOLATOR ROW DETAIL
NTS

INSPECTION & MAINTENANCE

- STEP 1) INSPECT ISOLATOR ROW FOR SEDIMENT
- A. INSPECTION PORTS (IF PRESENT)
 - A.1. REMOVE/OPEN LID ON NYLOPLAST INLINE DRAIN
 - A.2. REMOVE AND CLEAN FLEXSTORM FILTER IF INSTALLED
 - A.3. USING A FLASHLIGHT AND STADIA ROD, MEASURE DEPTH OF SEDIMENT AND RECORD ON MAINTENANCE LOG
 - A.4. LOWER A CAMERA INTO ISOLATOR ROW FOR VISUAL INSPECTION OF SEDIMENT LEVELS (OPTIONAL)
 - A.5. IF SEDIMENT IS AT, OR ABOVE, 3" (80 mm) PROCEED TO STEP 2. IF NOT, PROCEED TO STEP 3.
 - B. ALL ISOLATOR ROWS
 - B.1. REMOVE COVER FROM STRUCTURE AT UPSTREAM END OF ISOLATOR ROW
 - B.2. USING A FLASHLIGHT, INSPECT DOWN THE ISOLATOR ROW THROUGH OUTLET PIPE
 - i) MIRRORS ON POLES OR CAMERAS MAY BE USED TO AVOID A CONFINED SPACE ENTRY
 - ii) FOLLOW OSHA REGULATIONS FOR CONFINED SPACE ENTRY IF ENTERING MANHOLE
 - B.3. IF SEDIMENT IS AT, OR ABOVE, 3" (80 mm) PROCEED TO STEP 2. IF NOT, PROCEED TO STEP 3.
- STEP 2) CLEAN OUT ISOLATOR ROW USING THE JETVAC PROCESS
- A. A FIXED CULVERT CLEANING NOZZLE WITH REAR FACING SPREAD OF 45" (1.1 m) OR MORE IS PREFERRED
 - B. APPLY MULTIPLE PASSES OF JETVAC UNTIL BACKFLUSH WATER IS CLEAN
 - C. VACUUM STRUCTURE SUMP AS REQUIRED
- STEP 3) REPLACE ALL COVERS, GRATES, FILTERS, AND LIDS; RECORD OBSERVATIONS AND ACTIONS.
- STEP 4) INSPECT AND CLEAN BASINS AND MANHOLES UPSTREAM OF THE STORMTECH SYSTEM.

NOTES

1. INSPECT EVERY 6 MONTHS DURING THE FIRST YEAR OF OPERATION. ADJUST THE INSPECTION INTERVAL BASED ON PREVIOUS OBSERVATIONS OF SEDIMENT ACCUMULATION AND HIGH WATER ELEVATIONS.
2. CONDUCT JETTING AND VACTORING ANNUALLY OR WHEN INSPECTION SHOWS THAT MAINTENANCE IS NECESSARY.

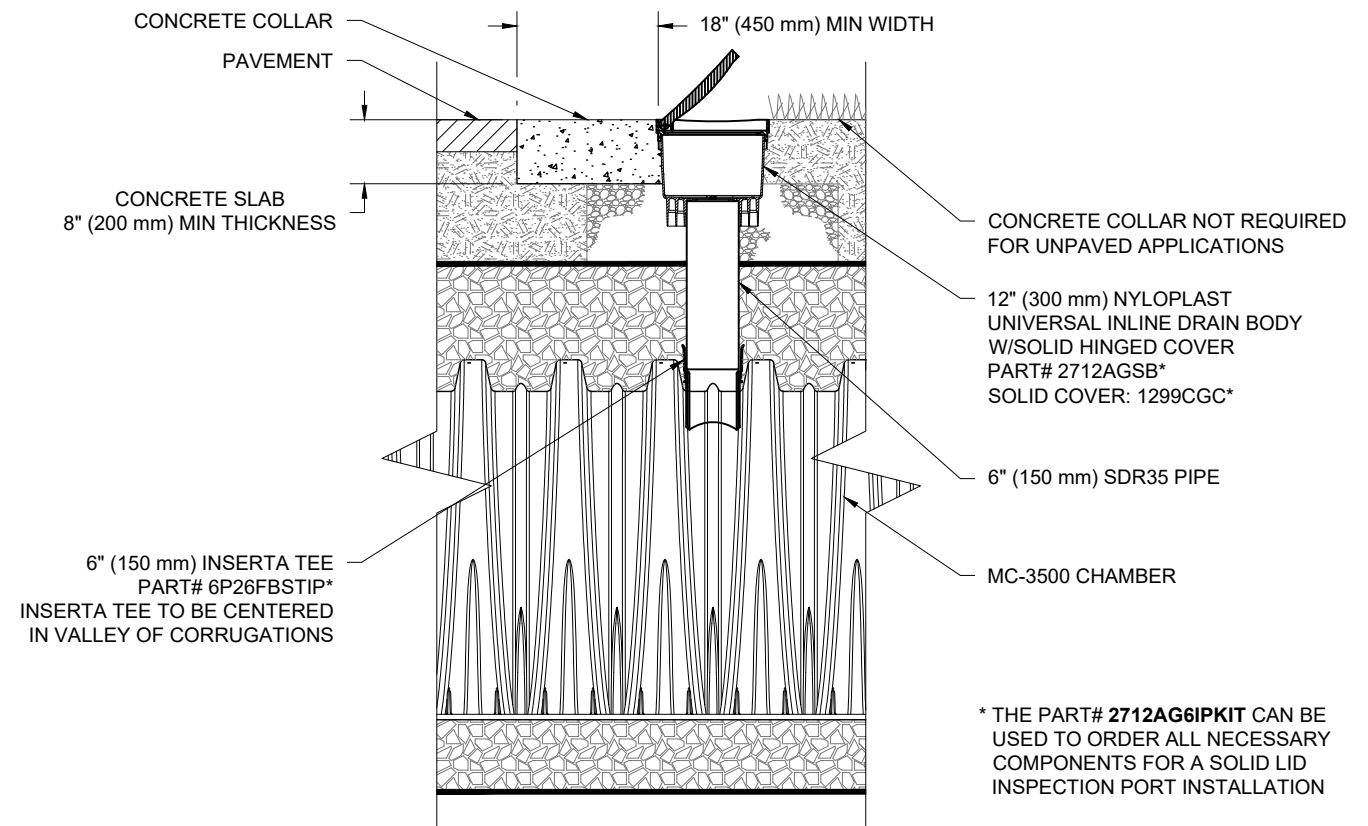

MC-3500 6" (150 mm) INSPECTION PORT DETAIL
NTS

112 MONTREAL ROAD
OTTAWA, ON.
DATE: 01/25/23 DRAWN: JR
PROJECT #: S334625 CHECKED: RWD

DATE	DRWN	CHKD	DESCRIPTION
2/23/23	RCT	RCT	VOLUME ABOVE OUTLET/ADD CHAMBERS
02/03/23	RCT	RCT	REVISED PER NEW PLAN

StormTech®
Chamber System
888-892-2694 | WWW.STORMTECH.COM

4640 TRUJEMAN BLVD
HILLIARD, OH 43026

ADS

THIS DRAWING HAS BEEN PREPARED BASED ON INFORMATION PROVIDED TO ADS UNDER THE DIRECTION OF THE SITE DESIGN ENGINEER OR OTHER PROJECT REPRESENTATIVE. THE SITE DESIGN ENGINEER SHALL REVIEW THIS DRAWING PRIOR TO CONSTRUCTION. IT IS THE ULTIMATE RESPONSIBILITY OF THE SITE DESIGN ENGINEER TO ENSURE THAT THE PRODUCT(S) DEPICTED AND ALL ASSOCIATED DETAILS MEET ALL APPLICABLE LAWS, REGULATIONS, AND PROJECT REQUIREMENTS.

MC-3500 TECHNICAL SPECIFICATION

NTS

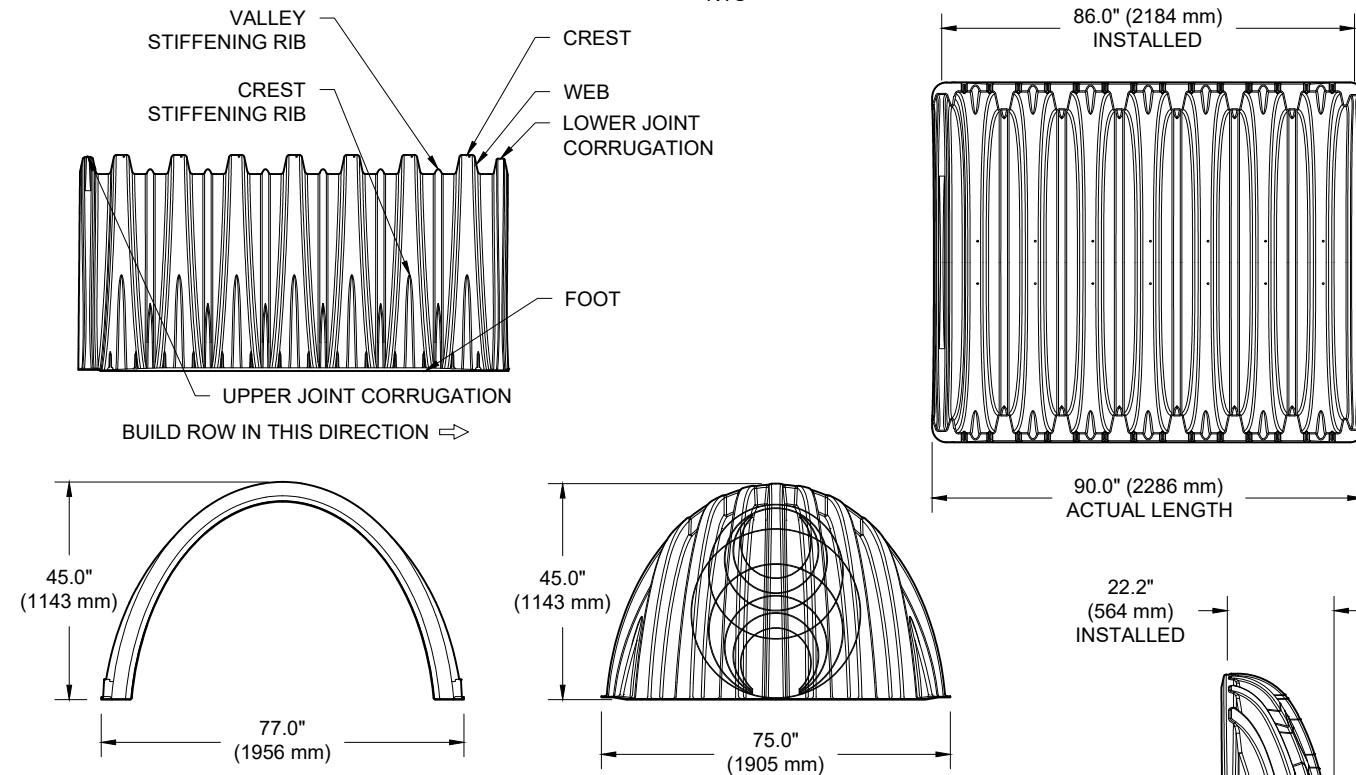

NOMINAL CHAMBER SPECIFICATIONS		
SIZE (W X H X INSTALLED LENGTH)	77.0" X 45.0" X 86.0"	(1956 mm X 1143 mm X 2184 mm)
CHAMBER STORAGE	109.9 CUBIC FEET	(3.11 m ³)
MINIMUM INSTALLED STORAGE*	175.0 CUBIC FEET	(4.96 m ³)
WEIGHT	134 lbs.	(60.8 kg)

NOMINAL END CAP SPECIFICATIONS		
SIZE (W X H X INSTALLED LENGTH)	75.0" X 45.0" X 22.2"	(1905 mm X 1143 mm X 564 mm)
END CAP STORAGE	14.9 CUBIC FEET	(0.42 m ³)
MINIMUM INSTALLED STORAGE*	45.1 CUBIC FEET	(1.28 m ³)
WEIGHT	49 lbs.	(22.2 kg)

*ASSUMES 12" (305 mm) STONE ABOVE, 9" (229 mm) STONE FOUNDATION, 6" (152 mm) STONE BETWEEN CHAMBERS, 6" (152 mm) STONE PERIMETER IN FRONT OF END CAPS AND 40% STONE POROSITY.

PARTIAL CUT HOLES AT BOTTOM OF END CAP FOR PART NUMBERS ENDING WITH "B"
 PARTIAL CUT HOLES AT TOP OF END CAP FOR PART NUMBERS ENDING WITH "T"
 END CAPS WITH A PREFABRICATED WELDED STUB END WITH "W"
 END CAPS WITH A WELDED CROWN PLATE END WITH "C"

PART #	STUB	B	C
MC3500IEPP06T	6" (150 mm)	33.21" (844 mm)	---
MC3500IEPP06B		---	0.66" (17 mm)
MC3500IEPP08T	8" (200 mm)	31.16" (791 mm)	---
MC3500IEPP08B		---	0.81" (21 mm)
MC3500IEPP10T	10" (250 mm)	29.04" (738 mm)	---
MC3500IEPP10B		---	0.93" (24 mm)
MC3500IEPP12T	12" (300 mm)	26.36" (670 mm)	---
MC3500IEPP12B		---	1.35" (34 mm)
MC3500IEPP15T	15" (375 mm)	23.39" (594 mm)	---
MC3500IEPP15B		---	1.50" (38 mm)
MC3500IEPP18TC	18" (450 mm)	20.03" (509 mm)	---
MC3500IEPP18TW			---
MC3500IEPP18BC		---	1.77" (45 mm)
MC3500IEPP18BW		---	---
MC3500IEPP24TC	24" (600 mm)	14.48" (368 mm)	---
MC3500IEPP24TW			---
MC3500IEPP24BC		---	2.06" (52 mm)
MC3500IEPP24BW		---	---
MC3500IEPP30BC	30" (750 mm)	---	2.75" (70 mm)

CUSTOM PARTIAL CUT INVERTS ARE AVAILABLE UPON REQUEST. INVENTORIED MANIFOLDS INCLUDE 12-24" (300-600 mm) SIZE ON SIZE AND 15-48" (375-1200 mm) ECCENTRIC MANIFOLDS. CUSTOM INVERT LOCATIONS ON THE MC-3500 END CAP CUT IN THE FIELD ARE NOT RECOMMENDED FOR PIPE SIZES GREATER THAN 10" (250 mm). THE INVERT LOCATION IN COLUMN "B" ARE THE HIGHEST POSSIBLE FOR THE PIPE SIZE.

MC-SERIES END CAP INSERTION DETAIL

NTS

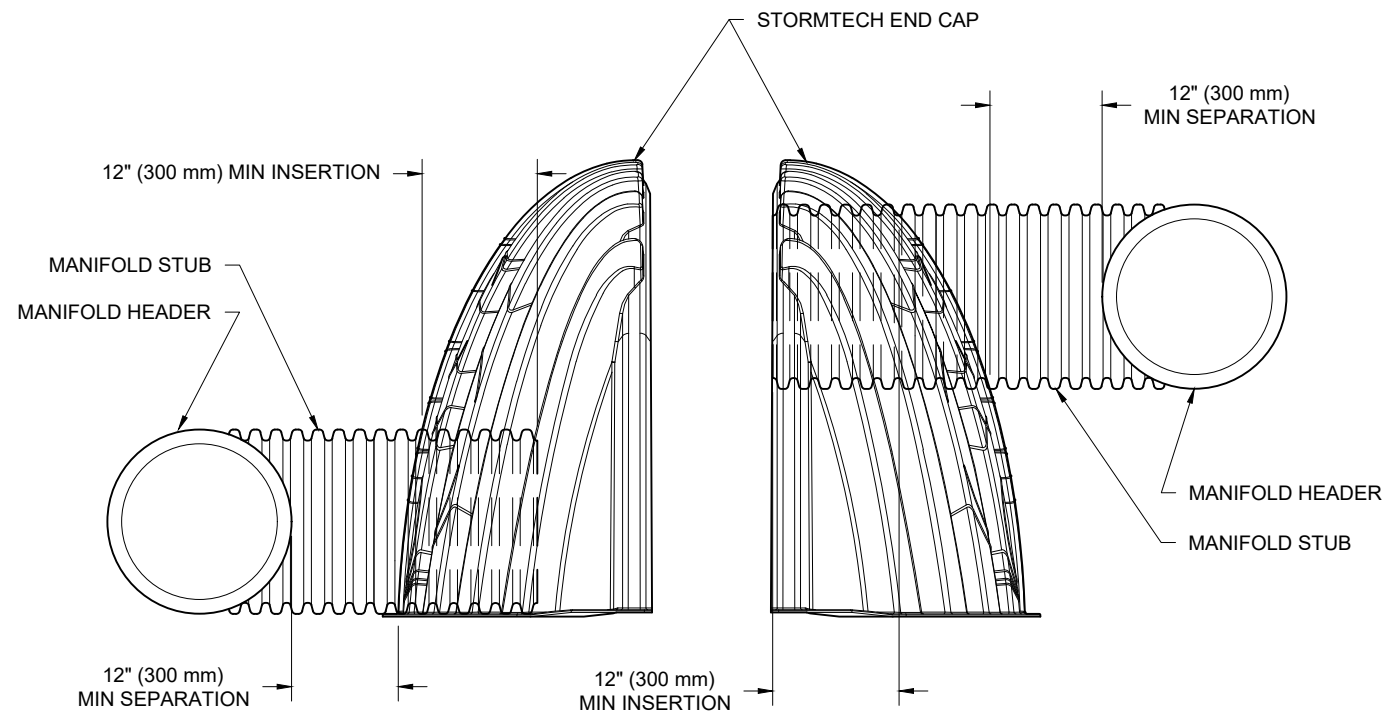

NOTE: MANIFOLD STUB MUST BE LAID HORIZONTAL FOR A PROPER FIT IN END CAP OPENING.

NOTE: ALL DIMENSIONS ARE NOMINAL

112 MONTREAL ROAD

OTTAWA, ON.

DATE: 01/25/23 DRAWN: JR
 PROJECT #: S334625 CHECKED: RWD

DATE	DESCRIPTION
2/23/23	RCT VOLUME ABOVE OUTLET/ADD CHAMBERS
02/03/23	RCT REVISED PER NEW PLAN
	DRWN CHKD

StormTech®
 Chamber System
 888-892-2694 | WWW.STORMTECH.COM

4640 TRUEMAN BLVD
 HILLIARD, OH 43026



THIS DRAWING HAS BEEN PREPARED BASED ON INFORMATION PROVIDED TO ADS UNDER THE DIRECTION OF THE SITE DESIGN ENGINEER OR OTHER PROJECT REPRESENTATIVE. THE SITE DESIGN ENGINEER SHALL REVIEW THIS DRAWING PRIOR TO CONSTRUCTION. IT IS THE ULTIMATE RESPONSIBILITY OF THE SITE DESIGN ENGINEER TO ENSURE THAT THE PRODUCT(S) DEPICTED AND ALL ASSOCIATED DETAILS MEET ALL APPLICABLE LAWS, REGULATIONS, AND PROJECT REQUIREMENTS.

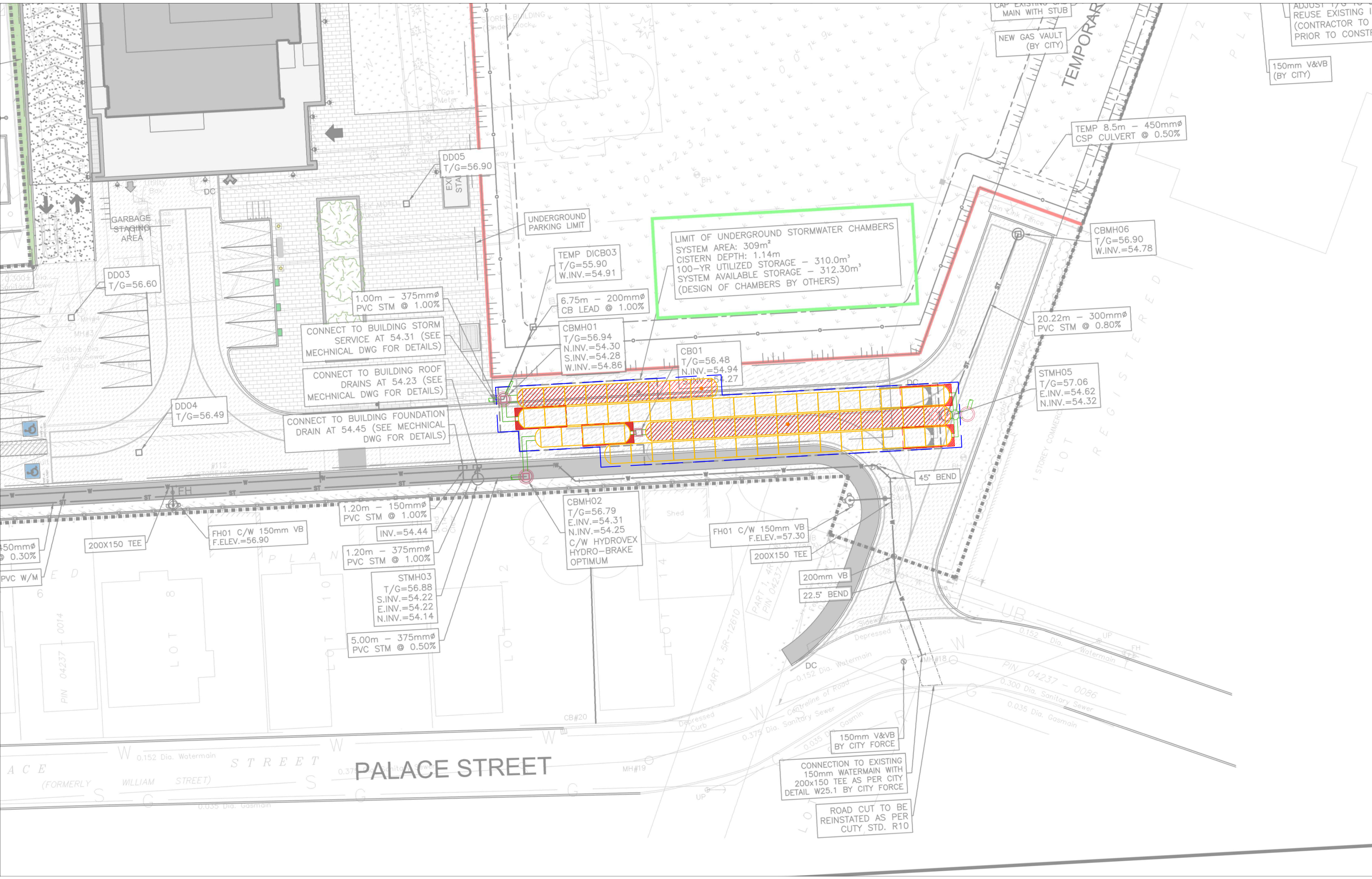

ADJUST 175 TO REUSE EXISTING (CONTRACTOR TO PRIOR TO CONSTRUCTION)

150mm V&VB (BY CITY)

LIMIT OF UNDERGROUND STORMWATER CHAMBERS
 SYSTEM AREA: 309m²
 CISTERN DEPTH: 1.14m
 100-YR UTILIZED STORAGE - 310.0m³
 SYSTEM AVAILABLE STORAGE - 312.30m³
 (DESIGN OF CHAMBERS BY OTHERS)

CONNECT TO BUILDING STORM SERVICE AT 54.31 (SEE MECHANICAL DWG FOR DETAILS)

CONNECT TO BUILDING ROOF DRAINS AT 54.23 (SEE MECHANICAL DWG FOR DETAILS)

CONNECT TO BUILDING FOUNDATION DRAIN AT 54.45 (SEE MECHANICAL DWG FOR DETAILS)

150mm V&VB BY CITY FORCE

CONNECTION TO EXISTING 150mm WATERMAIN WITH 200x150 TEE AS PER CITY DETAIL W25.1 BY CITY FORCE

ROAD CUT TO BE REINSTATED AS PER CUTY STD. R10

Project: 112 Montreal Road Rev2



Include Perimeter Stone in Calculations

Click for Stage Area Data

Click to Invert Stage Area Data

[Click Here for Imperial](#)

Chamber Model -	MC-3500
Units -	Metric
Number of Chambers -	63
Number of End Caps -	10
Void in the stone (porosity) -	40 %
Base of Stone Elevation -	54.00 m
Amount of Stone Above Chambers -	305 mm
Amount of Stone Below Chambers -	229 mm

348.4 sq.meters Min. Area - 305.14 sq.meters

StormTech MC-3500 Cumulative Storage Volumes

Height of System (mm)	Incremental Single Chamber (cubic meters)	Incremental Single End Cap (cubic meters)	Incremental Chambers (cubic meters)	Incremental End Cap (cubic meters)	Incremental Stone (cubic meters)	Incremental Ch, EC and Stone (cubic meters)	Cumulative System (cubic meters)	Elevation (meters)
1676	0.00	0.00	0.00	0.00	3.538	3.54	353.73	55.68
1651	0.00	0.00	0.00	0.00	3.538	3.54	350.19	55.65
1626	0.00	0.00	0.00	0.00	3.538	3.54	346.66	55.62
1600	0.00	0.00	0.00	0.00	3.538	3.54	343.12	55.60
1575	0.00	0.00	0.00	0.00	3.538	3.54	339.58	55.57
1549	0.00	0.00	0.00	0.00	3.538	3.54	336.04	55.55
1524	0.00	0.00	0.00	0.00	3.538	3.54	332.50	55.52
1499	0.00	0.00	0.00	0.00	3.538	3.54	328.97	55.50
1473	0.00	0.00	0.00	0.00	3.538	3.54	325.43	55.47
1448	0.00	0.00	0.00	0.00	3.538	3.54	321.89	55.45
1422	0.00	0.00	0.00	0.00	3.538	3.54	318.35	55.42
1397	0.00	0.00	0.00	0.00	3.538	3.54	314.82	55.40
1372	0.00	0.00	0.10	0.00	3.497	3.60	311.28	55.37
1346	0.01	0.00	0.35	0.01	3.397	3.75	307.68	55.35
1321	0.01	0.00	0.52	0.01	3.324	3.86	303.93	55.32
1295	0.01	0.00	0.72	0.01	3.244	3.98	300.07	55.29
1270	0.02	0.00	1.23	0.02	3.040	4.28	296.09	55.27
1245	0.03	0.00	1.83	0.02	2.794	4.65	291.80	55.24
1219	0.04	0.00	2.23	0.03	2.634	4.89	287.15	55.22
1194	0.04	0.00	2.54	0.04	2.509	5.08	282.26	55.19
1168	0.04	0.00	2.81	0.04	2.399	5.25	277.18	55.17
1143	0.05	0.00	3.05	0.05	2.301	5.39	271.93	55.14
1118	0.05	0.01	3.26	0.05	2.213	5.53	266.54	55.12
1092	0.05	0.01	3.46	0.06	2.132	5.65	261.01	55.09
1067	0.06	0.01	3.64	0.06	2.057	5.76	255.36	55.07
1041	0.06	0.01	3.81	0.07	1.988	5.86	249.60	55.04
1016	0.06	0.01	3.97	0.07	1.922	5.96	243.74	55.02
991	0.07	0.01	4.12	0.08	1.862	6.05	237.78	54.99
965	0.07	0.01	4.25	0.08	1.805	6.14	231.73	54.96
940	0.07	0.01	4.39	0.08	1.750	6.22	225.59	54.94
914	0.07	0.01	4.51	0.09	1.699	6.30	219.37	54.91
889	0.07	0.01	4.63	0.09	1.651	6.37	213.07	54.89
864	0.08	0.01	4.74	0.09	1.605	6.44	206.70	54.86
838	0.08	0.01	4.84	0.10	1.561	6.50	200.27	54.84
813	0.08	0.01	4.94	0.10	1.520	6.57	193.76	54.81
787	0.08	0.01	5.04	0.11	1.480	6.62	187.20	54.79
762	0.08	0.01	5.13	0.11	1.443	6.68	180.57	54.76
737	0.08	0.01	5.22	0.11	1.406	6.74	173.89	54.74
711	0.08	0.01	5.30	0.12	1.373	6.79	167.16	54.71
686	0.09	0.01	5.37	0.12	1.341	6.83	160.37	54.68
660	0.09	0.01	5.45	0.12	1.311	6.88	153.54	54.66
635	0.09	0.01	5.52	0.12	1.280	6.92	146.66	54.63
610	0.09	0.01	5.58	0.13	1.253	6.97	139.73	54.61
584	0.09	0.01	5.65	0.13	1.227	7.00	132.77	54.58
559	0.09	0.01	5.71	0.13	1.202	7.04	125.76	54.56
533	0.09	0.01	5.76	0.14	1.178	7.08	118.72	54.53
508	0.09	0.01	5.82	0.14	1.155	7.11	111.64	54.51
483	0.09	0.01	5.87	0.14	1.134	7.14	104.53	54.48
457	0.09	0.01	5.92	0.14	1.113	7.18	97.39	54.46
432	0.09	0.01	5.97	0.15	1.093	7.20	90.21	54.43
406	0.10	0.01	6.01	0.15	1.075	7.23	83.01	54.41
381	0.10	0.01	6.05	0.15	1.057	7.26	75.77	54.38
356	0.10	0.02	6.09	0.15	1.041	7.28	68.51	54.35
330	0.10	0.02	6.13	0.15	1.024	7.31	61.23	54.33
305	0.10	0.02	6.17	0.16	1.008	7.33	53.92	54.30
279	0.10	0.02	6.21	0.16	0.993	7.36	46.59	54.28
254	0.10	0.02	6.25	0.17	0.969	7.39	39.23	54.25
229	0.00	0.00	0.00	0.00	3.538	3.54	31.84	54.23
203	0.00	0.00	0.00	0.00	3.538	3.54	28.30	54.20
178	0.00	0.00	0.00	0.00	3.538	3.54	24.77	54.18
152	0.00	0.00	0.00	0.00	3.538	3.54	21.23	54.15
127	0.00	0.00	0.00	0.00	3.538	3.54	17.69	54.13
102	0.00	0.00	0.00	0.00	3.538	3.54	14.15	54.10
76	0.00	0.00	0.00	0.00	3.538	3.54	10.61	54.08
51	0.00	0.00	0.00	0.00	3.538	3.54	7.08	54.05
25	0.00	0.00	0.00	0.00	3.538	3.54	3.54	54.02

310.09m³ above elevation 54.268

APPENDIX

G

HYDROCAD MODEL
OUTPUT

APPENDIX

G-1 *5-YEAR ANALYSIS* *(PEAK DISCHARGE)*

Area Listing (selected nodes)

Area (sq-meters)	C	Description (subcatchment-numbers)
3,790.0	0.71	S03 (43S)
720.0	0.74	S04 (43S)
250.0	0.61	S05 (43S)
5,200.0	0.80	S06 (43S)
690.0	0.80	S07 (43S)
105.0	0.90	S08 (47S)
99.0	0.58	S09 (47S)
500.0	0.90	Tower A (44S, 45S)
810.0	0.90	Tower B1 (44S, 46S)
12,164.0	0.77	TOTAL AREA

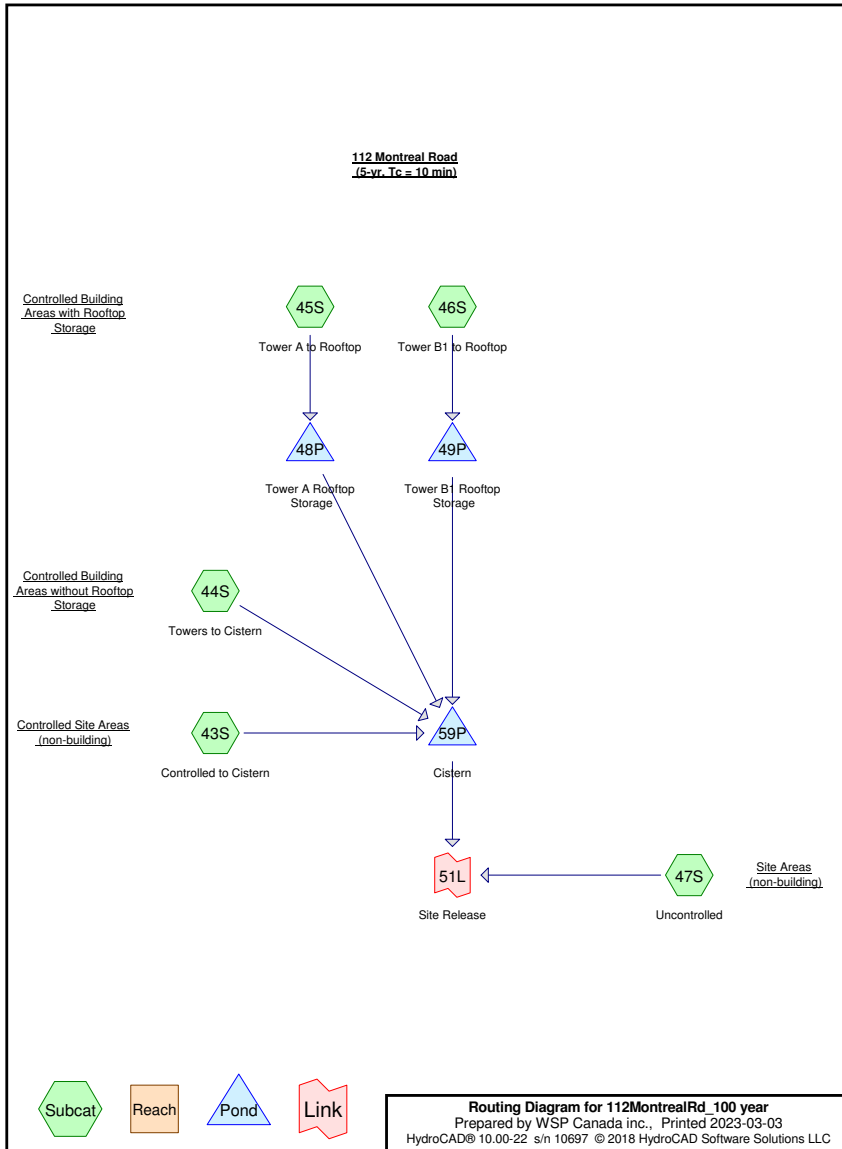

112MontrealRd_100 year

Prepared by WSP Canada inc.

HydroCAD® 10.00-22 s/n 10697 © 2018 HydroCAD Software Solutions LLC

Ottawa 5-Year Duration=21 min, Inten=68.1 mm/hr

Printed 2023-03-03

Page 3

Time span=0.00-4.00 hrs, dt=0.01 hrs, 401 points

Runoff by Rational method, Rise/Fall=1.0/1.0 xTc

Reach routing by Stor-Ind+Trans method - Pond routing by Stor-Ind method

Subcatchment 43S: Controlled to CisternRunoff Area=10,650.0 m² Runoff Depth=18 mm
Tc=10.0 min C=0.76 Runoff=0.1532 m³/s 193.0 m³**Subcatchment 44S: Towers to Cistern**Runoff Area=637.0 m² Runoff Depth=21 mm
Tc=10.0 min C=0.90 Runoff=0.0108 m³/s 13.7 m³**Subcatchment 45S: Tower A to Rooftop**Runoff Area=310.0 m² Runoff Depth=21 mm
Tc=10.0 min C=0.90 Runoff=0.0053 m³/s 6.7 m³**Subcatchment 46S: Tower B1 to Rooftop**Runoff Area=363.0 m² Runoff Depth=21 mm
Tc=10.0 min C=0.90 Runoff=0.0062 m³/s 7.8 m³**Subcatchment 47S: Uncontrolled**Runoff Area=204.0 m² Runoff Depth=18 mm
Tc=10.0 min C=0.74 Runoff=0.0029 m³/s 3.6 m³**Pond 48P: Tower A Rooftop Storage**Peak Elev=100.053 m Storage=4.3 m³ Inflow=0.0053 m³/s 6.7 m³
Outflow=0.0015 m³/s 6.7 m³**Pond 49P: Tower B1 Rooftop Storage**Peak Elev=100.069 m Storage=5.8 m³ Inflow=0.0062 m³/s 7.8 m³
Outflow=0.0012 m³/s 7.8 m³**Pond 59P: Cistern**Peak Elev=54.660 m Storage=114.2 m³ Inflow=0.1668 m³/s 221.1 m³
Primary=0.1076 m³/s 216.4 m³ Secondary=0.0000 m³/s 0.0 m³ Outflow=0.1076 m³/s 216.4 m³**Link 51L: Site Release**Inflow=0.1097 m³/s 220.0 m³
Primary=0.1097 m³/s 220.0 m³**Total Runoff Area = 12,164.0 m² Runoff Volume = 224.7 m³ Average Runoff Depth = 18 mm****112MontrealRd_100 year**

Prepared by WSP Canada inc.

HydroCAD® 10.00-22 s/n 10697 © 2018 HydroCAD Software Solutions LLC

Ottawa 5-Year Duration=21 min, Inten=68.1 mm/hr

Printed 2023-03-03

Page 4

Summary for Subcatchment 43S: Controlled to CisternRunoff = 0.1532 m³/s @ 0.17 hrs, Volume= 193.0 m³, Depth= 18 mmRunoff by Rational method, Rise/Fall=1.0/1.0 xTc, Time Span= 0.00-4.00 hrs, dt= 0.01 hrs
Ottawa 5-Year Duration=21 min, Inten=68.1 mm/hr

Area (m ²)	C	Description
3,790.0	0.71	S03
5,200.0	0.80	S06
720.0	0.74	S04
250.0	0.61	S05
690.0	0.80	S07
10,650.0	0.76	Weighted Average

Tc (min)	Length (meters)	Slope (m/m)	Velocity (m/sec)	Capacity (m ³ /s)	Description
10.0					Direct Entry,

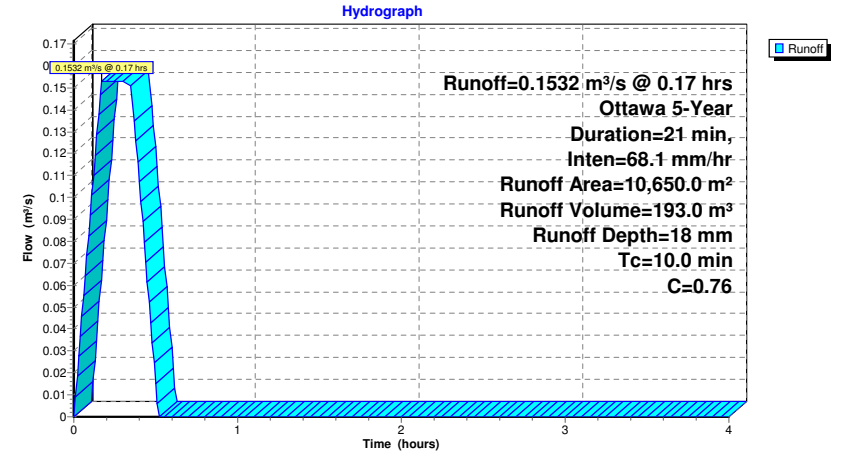
Subcatchment 43S: Controlled to Cistern

112MontrealRd_100 year

Prepared by WSP Canada inc.

HydroCAD® 10.00-22 s/n 10697 © 2018 HydroCAD Software Solutions LLC

Ottawa 5-Year Duration=21 min, Inten=68.1 mm/hr

Printed 2023-03-03

Page 5

Summary for Subcatchment 44S: Towers to Cistern

Runoff = 0.0108 m³/s @ 0.17 hrs, Volume= 13.7 m³, Depth= 21 mm

Runoff by Rational method, Rise/Fall=1.0/1.0 xTc, Time Span= 0.00-4.00 hrs, dt= 0.01 hrs
Ottawa 5-Year Duration=21 min, Inten=68.1 mm/hr

Area (m²)	C	Description
190.0	0.90	Tower A
447.0	0.90	Tower B1
637.0	0.90	Weighted Average

Tc (min)	Length (meters)	Slope (m/m)	Velocity (m/sec)	Capacity (m³/s)	Description
10.0					Direct Entry,

Subcatchment 44S: Towers to Cistern

Hydrograph

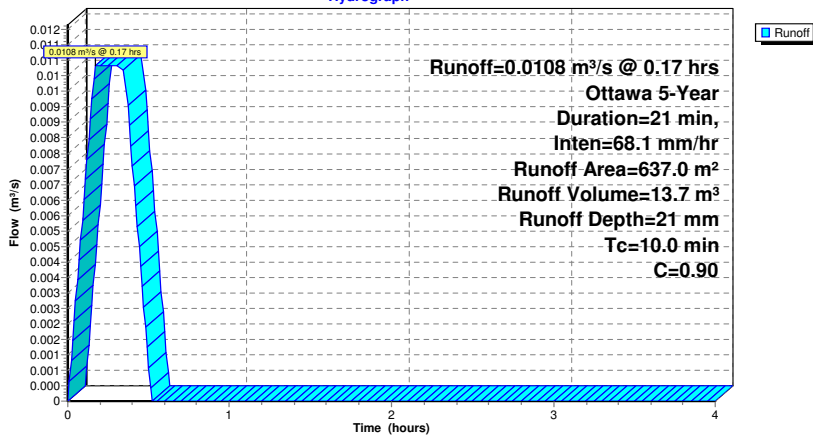

112MontrealRd_100 year

Prepared by WSP Canada inc.

HydroCAD® 10.00-22 s/n 10697 © 2018 HydroCAD Software Solutions LLC

Ottawa 5-Year Duration=21 min, Inten=68.1 mm/hr

Printed 2023-03-03

Page 6

Summary for Subcatchment 45S: Tower A to Rooftop

Runoff = 0.0053 m³/s @ 0.17 hrs, Volume= 6.7 m³, Depth= 21 mm

Runoff by Rational method, Rise/Fall=1.0/1.0 xTc, Time Span= 0.00-4.00 hrs, dt= 0.01 hrs
Ottawa 5-Year Duration=21 min, Inten=68.1 mm/hr

Area (m²)	C	Description
310.0	0.90	Tower A

Tc (min)	Length (meters)	Slope (m/m)	Velocity (m/sec)	Capacity (m³/s)	Description
10.0					Direct Entry,

Subcatchment 45S: Tower A to Rooftop

Hydrograph

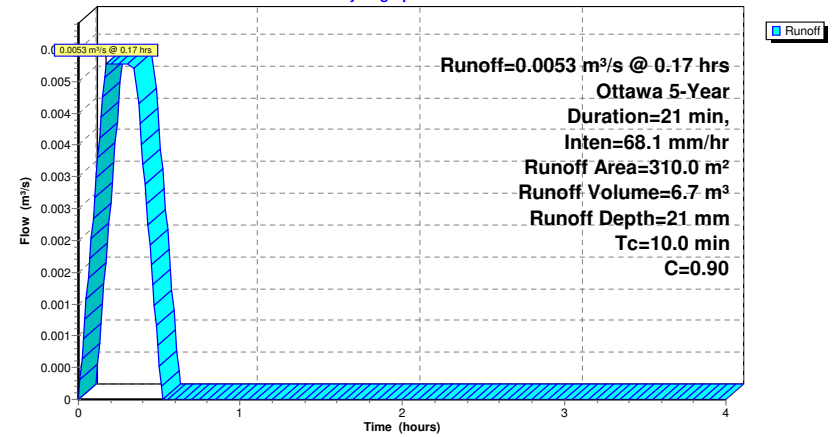

112MontrealRd_100 year

Ottawa 5-Year Duration=21 min, Inten=68.1 mm/hr

Prepared by WSP Canada inc.

Printed 2023-03-03

HydroCAD® 10.00-22 s/n 10697 © 2018 HydroCAD Software Solutions LLC

Page 7

Summary for Subcatchment 46S: Tower B1 to Rooftop

Runoff = 0.0062 m³/s @ 0.17 hrs, Volume= 7.8 m³, Depth= 21 mm

Runoff by Rational method, Rise/Fall=1.0/1.0 xTc, Time Span= 0.00-4.00 hrs, dt= 0.01 hrs
Ottawa 5-Year Duration=21 min, Inten=68.1 mm/hr

Area (m²)	C	Description
363.0	0.90	Tower B1

Tc (min)	Length (meters)	Slope (m/m)	Velocity (m/sec)	Capacity (m³/s)	Description
10.0					Direct Entry,

Subcatchment 46S: Tower B1 to Rooftop

Hydrograph

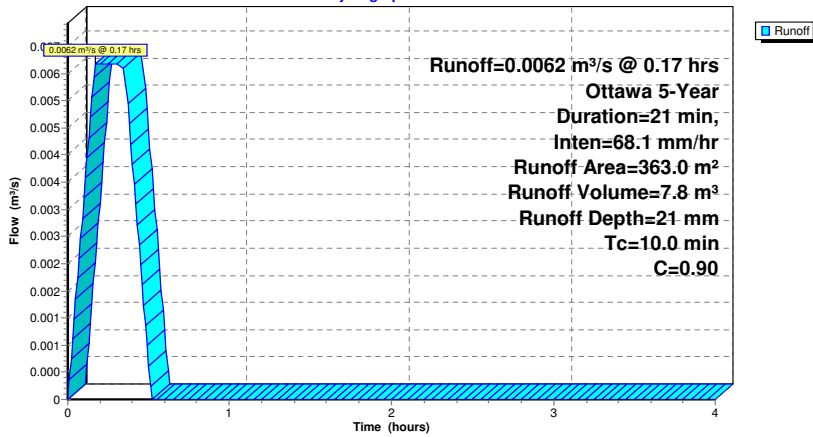

112MontrealRd_100 year

Ottawa 5-Year Duration=21 min, Inten=68.1 mm/hr

Prepared by WSP Canada inc.

Printed 2023-03-03

HydroCAD® 10.00-22 s/n 10697 © 2018 HydroCAD Software Solutions LLC

Page 8

Summary for Subcatchment 47S: Uncontrolled

Runoff = 0.0029 m³/s @ 0.17 hrs, Volume= 3.6 m³, Depth= 18 mm

Runoff by Rational method, Rise/Fall=1.0/1.0 xTc, Time Span= 0.00-4.00 hrs, dt= 0.01 hrs
Ottawa 5-Year Duration=21 min, Inten=68.1 mm/hr

Area (m²)	C	Description
99.0	0.58	S09
105.0	0.90	S08
204.0	0.74	Weighted Average

Tc (min)	Length (meters)	Slope (m/m)	Velocity (m/sec)	Capacity (m³/s)	Description
10.0					Direct Entry,

Subcatchment 47S: Uncontrolled

Hydrograph

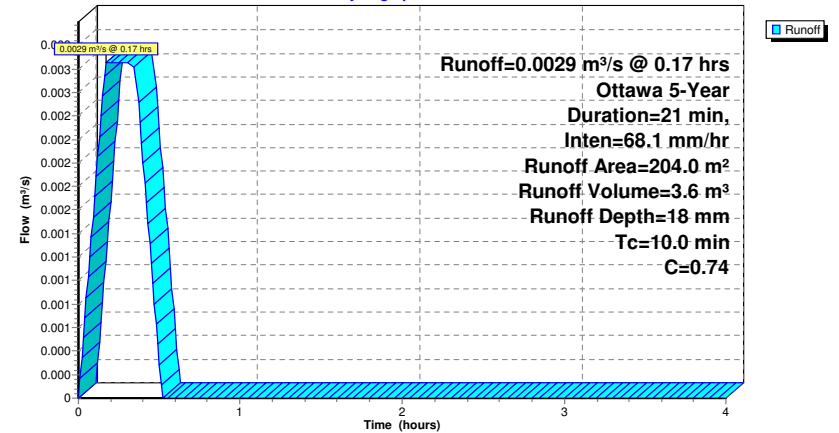

112MontrealRd_100 year

Prepared by WSP Canada inc.

HydroCAD® 10.00-22 s/n 10697 © 2018 HydroCAD Software Solutions LLC

Ottawa 5-Year Duration=21 min, Inten=68.1 mm/hr

Printed 2023-03-03

Page 9

Summary for Pond 48P: Tower A Rooftop Storage

Inflow Area = 310.0 m², Inflow Depth = 21 mm for 5-Year event
 Inflow = 0.0053 m³/s @ 0.17 hrs, Volume= 6.7 m³
 Outflow = 0.0015 m³/s @ 0.16 hrs, Volume= 6.7 m³, Atten= 71%, Lag= 0.0 min
 Primary = 0.0015 m³/s @ 0.16 hrs, Volume= 6.7 m³

Routing by Stor-Ind method, Time Span= 0.00-4.00 hrs, dt= 0.01 hrs
 Peak Elev= 100.053 m @ 0.47 hrs Surf.Area= 164.1 m² Storage= 4.3 m³

Plug-Flow detention time= 25.2 min calculated for 6.7 m³ (100% of inflow)
 Center-of-Mass det. time= 25.2 min (40.7 - 15.5)

Volume	Invert	Avail.Storage	Storage Description
#1	100.000 m	15.5 m ³	Custom Stage Data (Prismatic) Listed below (Recalc) x 5

Elevation (meters)	Surf.Area (sq-meters)	Inc.Store (cubic-meters)	Cum.Store (cubic-meters)
100.000	0.0	0.0	0.0
100.100	62.0	3.1	3.1

Device	Routing	Invert	Outlet Devices
#1	Primary	100.000 m	WATTS Accutrol_5-Closed X 5.00 Head (meters) 0.000 0.025 0.051 0.076 0.102 0.127 0.152 Disch. (m ³ /s) 0.00000 0.00031 0.00031 0.00031 0.00031 0.00031 0.00031 0.00031

Primary OutFlow Max=0.0015 m³/s @ 0.16 hrs HW=100.025 m (Free Discharge)
 1=WATTS Accutrol_5-Closed (Custom Controls 0.0015 m³/s)

112MontrealRd_100 year

Prepared by WSP Canada inc.

HydroCAD® 10.00-22 s/n 10697 © 2018 HydroCAD Software Solutions LLC

Ottawa 5-Year Duration=21 min, Inten=68.1 mm/hr

Printed 2023-03-03

Page 10

Pond 48P: Tower A Rooftop Storage

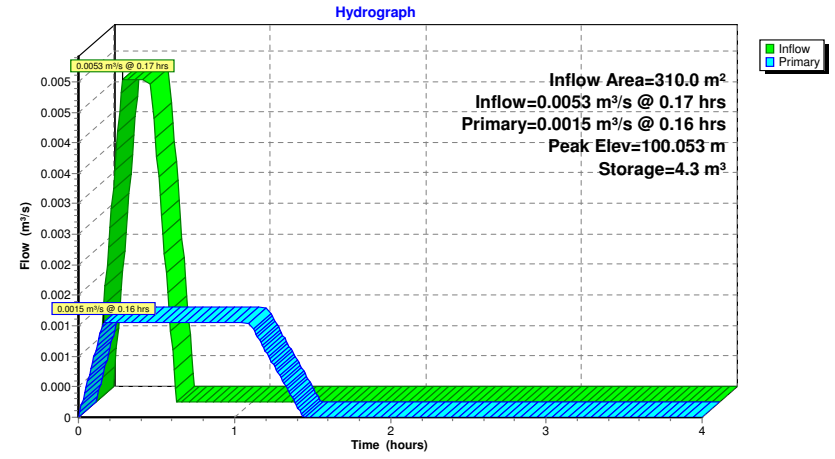

112MontrealRd_100 year

Prepared by WSP Canada inc.

HydroCAD® 10.00-22 s/n 10697 © 2018 HydroCAD Software Solutions LLC

Ottawa 5-Year Duration=21 min, Inten=68.1 mm/hr

Printed 2023-03-03

Page 11

Summary for Pond 49P: Tower B1 Rooftop Storage

Inflow Area = 363.0 m², Inflow Depth = 21 mm for 5-Year event
 Inflow = 0.0062 m³/s @ 0.17 hrs, Volume= 7.8 m³
 Outflow = 0.0012 m³/s @ 0.13 hrs, Volume= 7.8 m³, Atten= 80%, Lag= 0.0 min
 Primary = 0.0012 m³/s @ 0.13 hrs, Volume= 7.8 m³

Routing by Stor-Ind method, Time Span= 0.00-4.00 hrs, dt= 0.01 hrs
 Peak Elev= 100.069 m @ 0.48 hrs Surf.Area= 168.0 m² Storage= 5.8 m³

Plug-Flow detention time= 40.6 min calculated for 7.8 m³ (100% of inflow)
 Center-of-Mass det. time= 40.7 min (56.2 - 15.5)

Volume	Invert	Avail.Storage	Storage Description
#1	100.000 m	27.2 m ³	Custom Stage Data (Prismatic) Listed below (Recalc) x 4

Elevation (meters)	Surf.Area (sq-meters)	Inc.Store (cubic-meters)	Cum.Store (cubic-meters)
100.000	0.0	0.0	0.0
100.150	90.7	6.8	6.8

Device	Routing	Invert	Outlet Devices
#1	Primary	100.000 m	WATTS Accutrol_5-Closed X 4.00 Head (meters) 0.000 0.025 0.051 0.076 0.102 0.127 0.152 Disch. (m ³ /s) 0.00000 0.00031 0.00031 0.00031 0.00031 0.00031 0.00031 0.00031

Primary OutFlow Max=0.0012 m³/s @ 0.13 hrs HW=100.026 m (Free Discharge)
 ↳1=WATTS Accutrol_5-Closed (Custom Controls 0.0012 m³/s)

112MontrealRd_100 year

Prepared by WSP Canada inc.

HydroCAD® 10.00-22 s/n 10697 © 2018 HydroCAD Software Solutions LLC

Ottawa 5-Year Duration=21 min, Inten=68.1 mm/hr

Printed 2023-03-03

Page 12

Pond 49P: Tower B1 Rooftop Storage

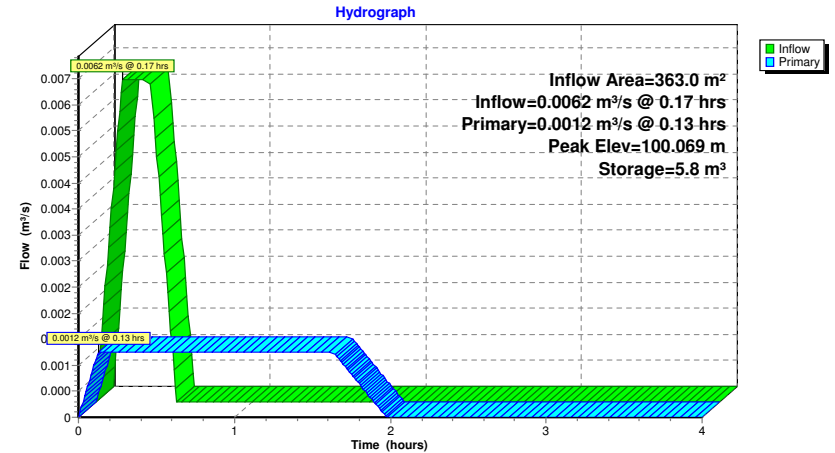

Summary for Pond 59P: Cistern

Inflow Area = 11,960.0 m², Inflow Depth = 18 mm for 5-Year event
 Inflow = 0.1668 m³/s @ 0.17 hrs, Volume= 221.1 m³
 Outflow = 0.1076 m³/s @ 0.41 hrs, Volume= 216.4 m³, Atten= 35%, Lag= 14.4 min
 Primary = 0.1076 m³/s @ 0.41 hrs, Volume= 216.4 m³
 Secondary = 0.0000 m³/s @ 0.00 hrs, Volume= 0.0 m³

Routing by Stor-Ind method, Time Span= 0.00-4.00 hrs, dt= 0.01 hrs
 Peak Elev= 54.660 m @ 0.41 hrs Surf.Area= 0.0 m² Storage= 114.2 m³

Plug-Flow detention time= 24.1 min calculated for 216.4 m³ (98% of inflow)
 Center-of-Mass det. time= 22.7 min (40.4 - 17.7)

Volume	Invert	Avail.Storage	Storage Description
#1	54.250 m	314.5 m ³	Custom Stage Data Listed below

Elevation (meters)	Cum.Store (cubic-meters)
54.250	0.0
54.280	7.4
54.350	29.3
54.460	58.2
54.560	86.5
54.660	114.3
54.760	141.3
54.860	167.5
54.960	192.5
55.070	216.1
55.170	238.0
55.270	256.9
55.370	272.1
55.470	286.2
55.570	300.4
55.680	314.5

Device	Routing	Invert	Outlet Devices
#1	Primary	54.250 m	SHE-0408-1120-1430-1120_HydroBrake Head (meters) 0.000 0.014 0.029 0.043 0.058 0.072 0.087 0.101 0.116 0.130 0.144 0.159 0.173 0.188 0.202 0.217 0.231 0.246 0.260 0.274 0.289 0.303 0.318 0.332 0.347 0.361 0.376 0.390 0.404 0.419 0.433 0.448 0.462 0.477 0.491 0.506 0.520 0.534 0.549 0.563 0.578 0.592 0.607 0.621 0.636 0.650 0.664 0.679 0.693 0.708 0.722 0.737 0.751 0.766 0.780 0.794 0.809 0.823 0.838 0.852 0.867 0.881 0.896 0.910 0.924 0.939 0.953 0.968 0.982 0.997 1.011 1.026 1.040 1.054 1.069 1.083 1.098 1.112 1.127 1.141 1.156 1.170 1.184 1.199 1.213 1.228 1.242 1.257 1.271 1.286 1.300 1.314 1.329 1.343 1.358 1.372 1.387 1.401 1.416 1.430 1.459 1.487 1.516 1.544 1.573 1.602 1.630 1.659 1.687 1.716 Disch. (m ³ /s) 0.00000 0.00025 0.00099 0.00220 0.00386 0.00596

0.00847	0.01137	0.01465	0.01827	0.02221	0.02646	0.03097
0.03574	0.04072	0.04588	0.05120	0.05663	0.06214	0.06769
0.07323	0.07874	0.08430	0.08953	0.09447	0.09917	0.10365
0.10677	0.10741	0.10800	0.10853	0.10901	0.10944	0.10982
0.11016	0.11045	0.11070	0.11092	0.11109	0.11123	0.11134
0.11142	0.11146	0.11148	0.11147	0.11144	0.11138	0.11131
0.11121	0.11109	0.11095	0.11080	0.11062	0.11043	0.11022
0.11000	0.10976	0.10950	0.10923	0.10893	0.10862	0.10829
0.10793	0.10755	0.10715	0.10672	0.10626	0.10577	0.10525
0.10469	0.10408	0.10344	0.10275	0.10200	0.10121	0.10035
0.09943	0.09904	0.09966	0.10028	0.10089	0.10150	0.10211
0.10271	0.10331	0.10390	0.10450	0.10508	0.10567	0.10625
0.10683	0.10740	0.10797	0.10854	0.10911	0.10967	0.11023
0.11078	0.11134	0.11189	0.11292	0.11396	0.11500	0.11604
0.11707	0.11811	0.11915	0.12018	0.12122	0.12226	

#2 Secondary 56.480 m *****Overflow Check**
 Head (meters) 0.000 0.010
 Disch. (m³/s) 0.00000 10.00000

Primary OutFlow Max=0.1076 m³/s @ 0.41 hrs HW=54.660 m (Free Discharge)
 #1=SHE-0408-1120-1430-1120_HydroBrake (Custom Controls 0.1076 m³/s)

Secondary OutFlow Max=0.0000 m³/s @ 0.00 hrs HW=54.250 m (Free Discharge)
 #2=***Overflow Check (Controls 0.0000 m³/s)

Pond 59P: Cistern

Hydrograph

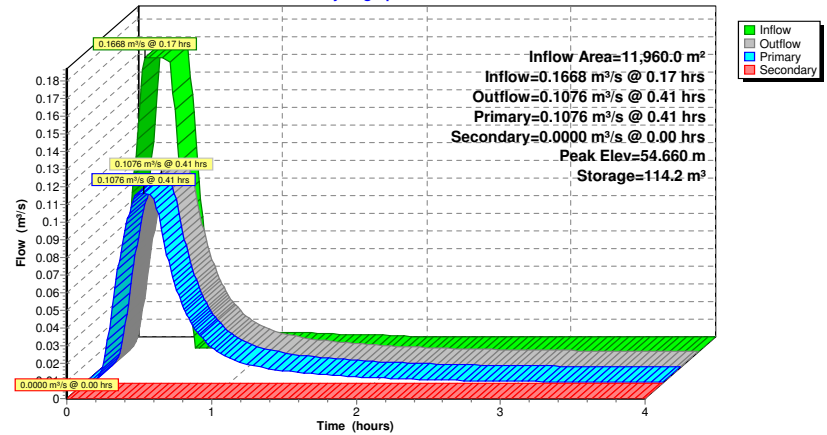

Summary for Link 51L: Site Release

Inflow Area = 12,164.0 m², Inflow Depth > 18 mm for 5-Year event
Inflow = 0.1097 m³/s @ 0.38 hrs, Volume= 220.0 m³
Primary = 0.1097 m³/s @ 0.38 hrs, Volume= 220.0 m³, Atten= 0%, Lag= 0.0 min

Primary outflow = Inflow, Time Span= 0.00-4.00 hrs, dt= 0.01 hrs

Link 51L: Site Release

Hydrograph

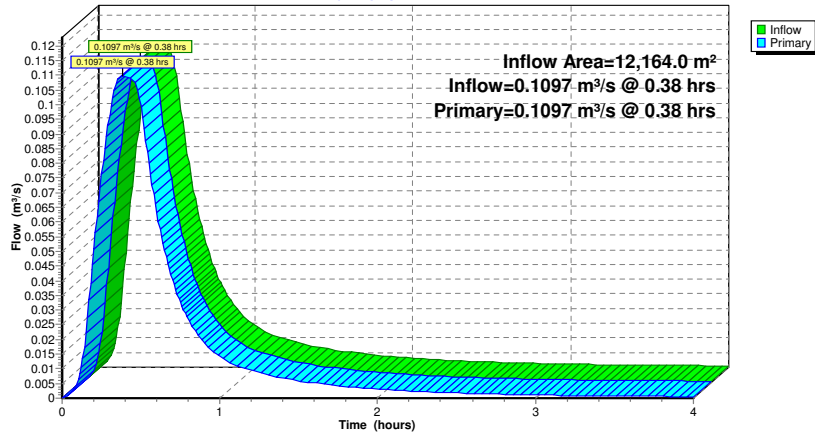

APPENDIX

G-2 *100-YEAR ANALYSIS (PEAK DISCHARGE)*

112MontrealRd_100 year

Prepared by WSP Canada inc.

HydroCAD® 10.00-22 s/n 10697 © 2018 HydroCAD Software Solutions LLC

Printed 2023-03-03

Page 2

Area Listing (selected nodes)

Area (sq-meters)	C	Description (subcatchment-numbers)
3,790.0	0.89	S03 (9S)
720.0	0.93	S04 (9S)
250.0	0.76	S05 (9S)
5,200.0	1.00	S06 (9S)
690.0	1.00	S07 (9S)
105.0	1.00	S08 (14S)
99.0	0.72	S09 (14S)
500.0	1.00	Tower A (10S, 11S)
810.0	1.00	Tower B1 (10S, 12S)
12,164.0	0.95	TOTAL AREA

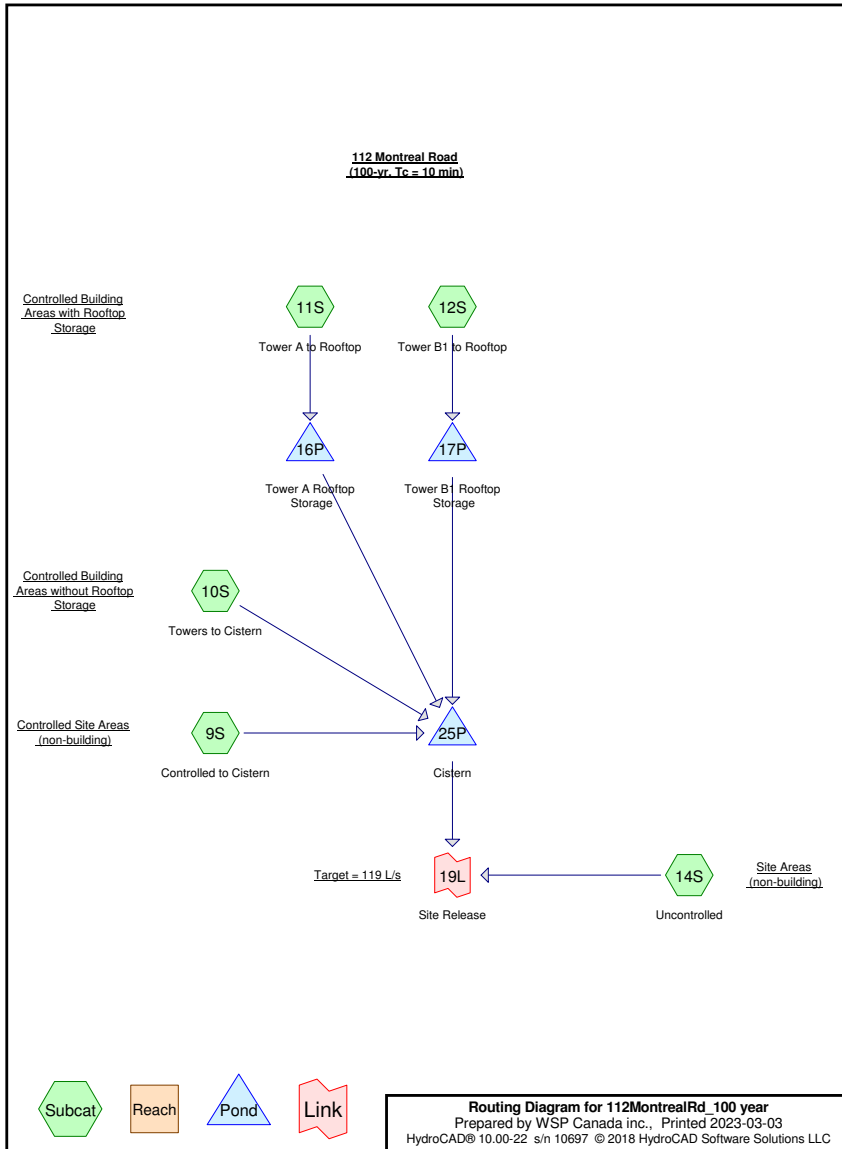

112MontrealRd_100 year

Prepared by WSP Canada inc.

HydroCAD® 10.00-22 s/n 10697 © 2018 HydroCAD Software Solutions LLC

Ottawa 100-Year Duration=11 min, Inten=169.9 mm/hr

Printed 2023-03-03

Page 3

Time span=0.00-4.00 hrs, dt=0.01 hrs, 401 points

Runoff by Rational method, Rise/Fall=1.0/1.0 xTc

Reach routing by Stor-Ind+Trans method - Pond routing by Stor-Ind method

Subcatchment 9S: Controlled to CisternRunoff Area=10,650.0 m² Runoff Depth=30 mm
Tc=10.0 min C=0.95 Runoff=0.4799 m³/s 314.9 m³**Subcatchment 10S: Towers to Cistern**Runoff Area=637.0 m² Runoff Depth=31 mm
Tc=10.0 min C=1.00 Runoff=0.0302 m³/s 19.8 m³**Subcatchment 11S: Tower A to Rooftop**Runoff Area=310.0 m² Runoff Depth=31 mm
Tc=10.0 min C=1.00 Runoff=0.0147 m³/s 9.6 m³**Subcatchment 12S: Tower B1 to Rooftop**Runoff Area=363.0 m² Runoff Depth=31 mm
Tc=10.0 min C=1.00 Runoff=0.0172 m³/s 11.3 m³**Subcatchment 14S: Uncontrolled**Runoff Area=204.0 m² Runoff Depth=27 mm
Tc=10.0 min C=0.86 Runoff=0.0083 m³/s 5.5 m³**Pond 16P: Tower A Rooftop Storage**Peak Elev=100.072 m Storage=8.0 m³ Inflow=0.0147 m³/s 9.6 m³
Outflow=0.0015 m³/s 9.6 m³**Pond 17P: Tower B1 Rooftop Storage**Peak Elev=100.122 m Storage=9.8 m³ Inflow=0.0172 m³/s 11.3 m³
Outflow=0.0012 m³/s 11.3 m³**Pond 25P: Cistern**Peak Elev=55.237 m Storage=250.6 m³ Inflow=0.5129 m³/s 355.7 m³
Primary=0.1115 m³/s 350.0 m³ Secondary=0.0000 m³/s 0.0 m³ Outflow=0.1115 m³/s 350.0 m³**Link 19L: Site Release**Inflow=0.1194 m³/s 355.5 m³
Primary=0.1194 m³/s 355.5 m³**Total Runoff Area = 12,164.0 m² Runoff Volume = 361.2 m³ Average Runoff Depth = 30 mm****112MontrealRd_100 year**

Prepared by WSP Canada inc.

HydroCAD® 10.00-22 s/n 10697 © 2018 HydroCAD Software Solutions LLC

Ottawa 100-Year Duration=11 min, Inten=169.9 mm/hr

Printed 2023-03-03

Page 4

Summary for Subcatchment 9S: Controlled to CisternRunoff = 0.4799 m³/s @ 0.18 hrs, Volume= 314.9 m³, Depth= 30 mmRunoff by Rational method, Rise/Fall=1.0/1.0 xTc, Time Span= 0.00-4.00 hrs, dt= 0.01 hrs
Ottawa 100-Year Duration=11 min, Inten=169.9 mm/hr

Area (m ²)	C	Description
3,790.0	0.89	S03
5,200.0	1.00	S06
720.0	0.93	S04
250.0	0.76	S05
690.0	1.00	S07
10,650.0	0.95	Weighted Average

Tc (min)	Length (meters)	Slope (m/m)	Velocity (m/sec)	Capacity (m ³ /s)	Description
10.0					Direct Entry,

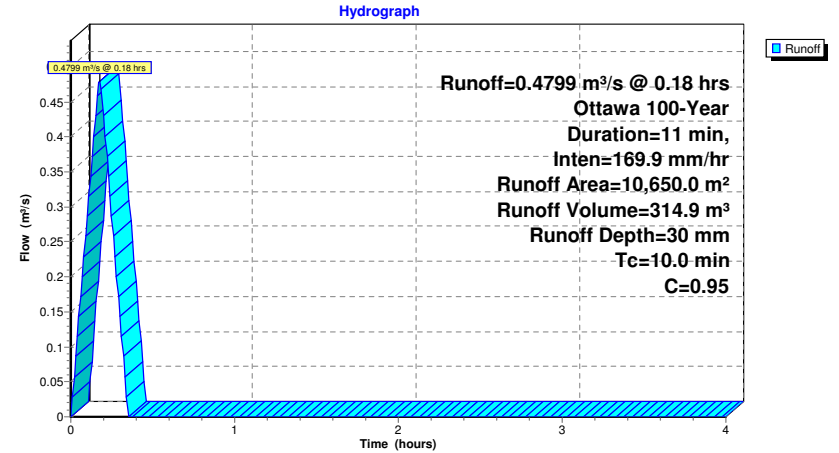
Subcatchment 9S: Controlled to Cistern

112MontrealRd_100 year

Ottawa 100-Year Duration=11 min, Inten=169.9 mm/hr

Prepared by WSP Canada inc.

Printed 2023-03-03

HydroCAD® 10.00-22 s/n 10697 © 2018 HydroCAD Software Solutions LLC

Page 5

Summary for Subcatchment 10S: Towers to Cistern

Runoff = 0.0302 m³/s @ 0.18 hrs, Volume= 19.8 m³, Depth= 31 mm

Runoff by Rational method, Rise/Fall=1.0/1.0 xTc, Time Span= 0.00-4.00 hrs, dt= 0.01 hrs
 Ottawa 100-Year Duration=11 min, Inten=169.9 mm/hr

Area (m²)	C	Description
190.0	1.00	Tower A
447.0	1.00	Tower B1
637.0	1.00	Weighted Average

Tc (min)	Length (meters)	Slope (m/m)	Velocity (m/sec)	Capacity (m³/s)	Description
10.0					Direct Entry,

Subcatchment 10S: Towers to Cistern

Hydrograph

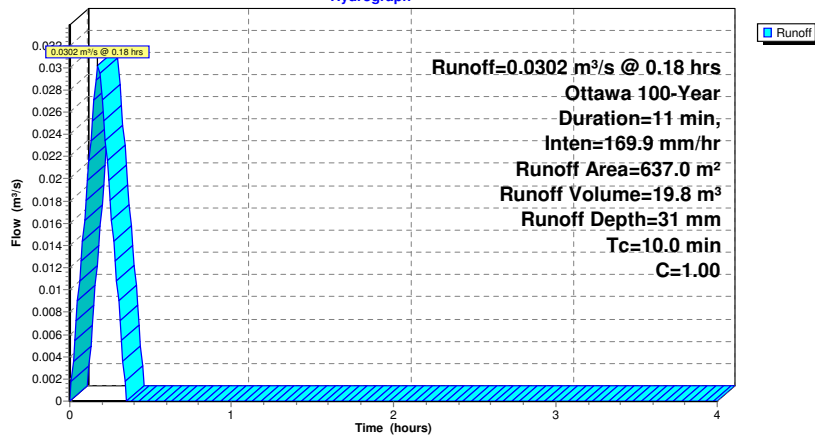

112MontrealRd_100 year

Ottawa 100-Year Duration=11 min, Inten=169.9 mm/hr

Prepared by WSP Canada inc.

Printed 2023-03-03

HydroCAD® 10.00-22 s/n 10697 © 2018 HydroCAD Software Solutions LLC

Page 6

Summary for Subcatchment 11S: Tower A to Rooftop

Runoff = 0.0147 m³/s @ 0.18 hrs, Volume= 9.6 m³, Depth= 31 mm

Runoff by Rational method, Rise/Fall=1.0/1.0 xTc, Time Span= 0.00-4.00 hrs, dt= 0.01 hrs
 Ottawa 100-Year Duration=11 min, Inten=169.9 mm/hr

Area (m²)	C	Description
310.0	1.00	Tower A

Tc (min)	Length (meters)	Slope (m/m)	Velocity (m/sec)	Capacity (m³/s)	Description
10.0					Direct Entry,

Subcatchment 11S: Tower A to Rooftop

Hydrograph

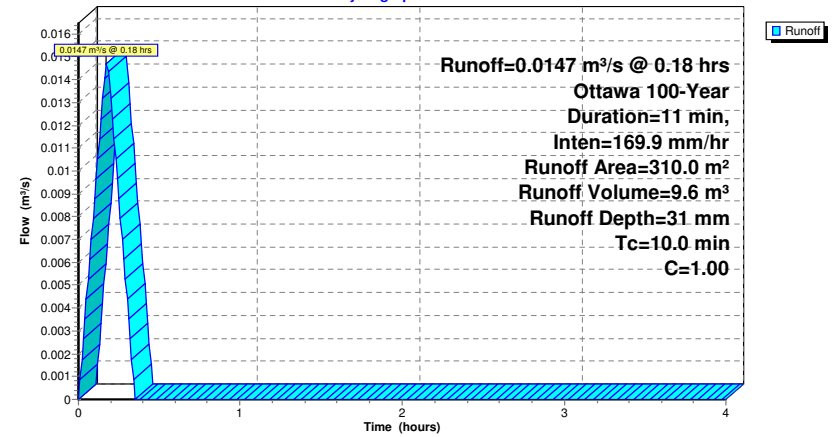

112MontrealRd_100 year

Ottawa 100-Year Duration=11 min, Inten=169.9 mm/hr

Prepared by WSP Canada inc.

Printed 2023-03-03

HydroCAD® 10.00-22 s/n 10697 © 2018 HydroCAD Software Solutions LLC

Page 7

Summary for Subcatchment 12S: Tower B1 to Rooftop

Runoff = 0.0172 m³/s @ 0.18 hrs, Volume= 11.3 m³, Depth= 31 mm

Runoff by Rational method, Rise/Fall=1.0/1.0 xTc, Time Span= 0.00-4.00 hrs, dt= 0.01 hrs
 Ottawa 100-Year Duration=11 min, Inten=169.9 mm/hr

Area (m²)	C	Description
363.0	1.00	Tower B1

Tc (min)	Length (meters)	Slope (m/m)	Velocity (m/sec)	Capacity (m³/s)	Description
10.0					Direct Entry,

Subcatchment 12S: Tower B1 to Rooftop

Hydrograph

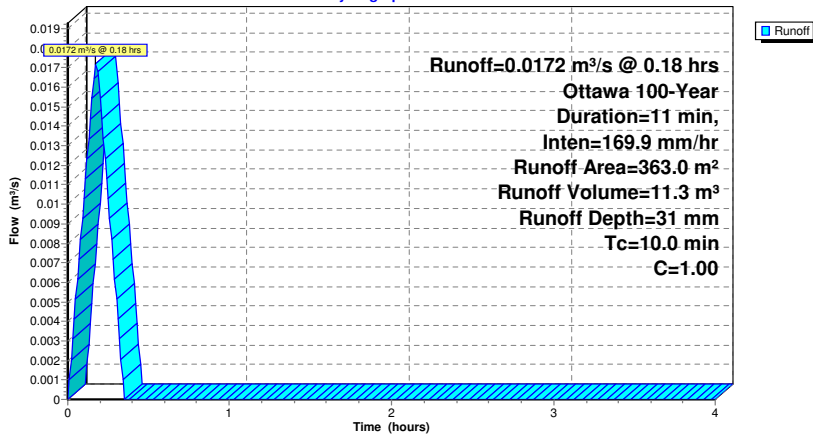

112MontrealRd_100 year

Ottawa 100-Year Duration=11 min, Inten=169.9 mm/hr

Prepared by WSP Canada inc.

Printed 2023-03-03

HydroCAD® 10.00-22 s/n 10697 © 2018 HydroCAD Software Solutions LLC

Page 8

Summary for Subcatchment 14S: Uncontrolled

Runoff = 0.0083 m³/s @ 0.18 hrs, Volume= 5.5 m³, Depth= 27 mm

Runoff by Rational method, Rise/Fall=1.0/1.0 xTc, Time Span= 0.00-4.00 hrs, dt= 0.01 hrs
 Ottawa 100-Year Duration=11 min, Inten=169.9 mm/hr

Area (m²)	C	Description
99.0	0.72	S09
105.0	1.00	S08
204.0	0.86	Weighted Average

Tc (min)	Length (meters)	Slope (m/m)	Velocity (m/sec)	Capacity (m³/s)	Description
10.0					Direct Entry,

Subcatchment 14S: Uncontrolled

Hydrograph

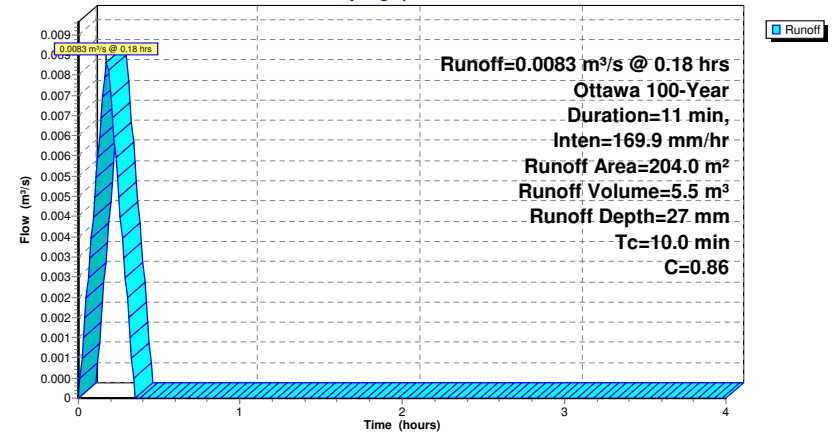

112MontrealRd_100 year

Prepared by WSP Canada inc.

HydroCAD® 10.00-22 s/n 10697 © 2018 HydroCAD Software Solutions LLC

Ottawa 100-Year Duration=11 min, Inten=169.9 mm/hr

Printed 2023-03-03

Page 9

Summary for Pond 16P: Tower A Rooftop Storage

Inflow Area = 310.0 m², Inflow Depth = 31 mm for 100-Year event
 Inflow = 0.0147 m³/s @ 0.18 hrs, Volume= 9.6 m³
 Outflow = 0.0015 m³/s @ 0.09 hrs, Volume= 9.6 m³, Atten= 89%, Lag= 0.0 min
 Primary = 0.0015 m³/s @ 0.09 hrs, Volume= 9.6 m³

Routing by Stor-Ind method, Time Span= 0.00-4.00 hrs, dt= 0.01 hrs
 Peak Elev= 100.072 m @ 0.33 hrs Surf.Area= 222.6 m² Storage= 8.0 m³

Plug-Flow detention time= 44.1 min calculated for 9.6 m³ (100% of inflow)
 Center-of-Mass det. time= 44.2 min (54.7 - 10.5)

Volume	Invert	Avail.Storage	Storage Description
#1	100.000 m	15.5 m ³	Custom Stage Data (Prismatic) Listed below (Recalc) x 5

Elevation (meters)	Surf.Area (sq-meters)	Inc.Store (cubic-meters)	Cum.Store (cubic-meters)
100.000	0.0	0.0	0.0
100.100	62.0	3.1	3.1

Device	Routing	Invert	Outlet Devices
#1	Primary	100.000 m	WATTS Accutrol_5-Closed X 5.00 Head (meters) 0.000 0.025 0.051 0.076 0.102 0.127 0.152 Disch. (m ³ /s) 0.00000 0.00031 0.00031 0.00031 0.00031 0.00031 0.00031 0.00031

Primary OutFlow Max=0.0015 m³/s @ 0.09 hrs HW=100.026 m (Free Discharge)
 ↳1=WATTS Accutrol_5-Closed (Custom Controls 0.0015 m³/s)

112MontrealRd_100 year

Prepared by WSP Canada inc.

HydroCAD® 10.00-22 s/n 10697 © 2018 HydroCAD Software Solutions LLC

Ottawa 100-Year Duration=11 min, Inten=169.9 mm/hr

Printed 2023-03-03

Page 10

Pond 16P: Tower A Rooftop Storage

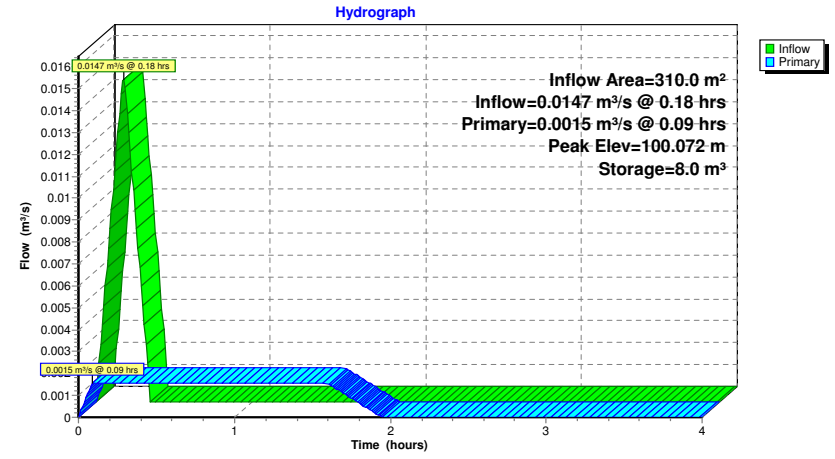

112MontrealRd_100 year

Prepared by WSP Canada inc.

HydroCAD® 10.00-22 s/n 10697 © 2018 HydroCAD Software Solutions LLC

Ottawa 100-Year Duration=11 min, Inten=169.9 mm/hr

Printed 2023-03-03

Page 11

Summary for Pond 17P: Tower B1 Rooftop Storage

Inflow Area = 363.0 m², Inflow Depth = 31 mm for 100-Year event
 Inflow = 0.0172 m³/s @ 0.18 hrs, Volume= 11.3 m³
 Outflow = 0.0012 m³/s @ 0.03 hrs, Volume= 11.3 m³, Atten= 93%, Lag= 0.0 min
 Primary = 0.0012 m³/s @ 0.03 hrs, Volume= 11.3 m³

Routing by Stor-Ind method, Time Span= 0.00-4.00 hrs, dt= 0.01 hrs
 Peak Elev= 100.122 m @ 0.34 hrs Surf.Area= 241.0 m² Storage= 9.8 m³

Plug-Flow detention time= 66.1 min calculated for 11.3 m³ (100% of inflow)
 Center-of-Mass det. time= 66.2 min (76.7 - 10.5)

Volume	Invert	Avail.Storage	Storage Description
#1	100.000 m	18.1 m ³	Custom Stage Data (Pyramidal) Listed below (Recalc) x 4

Elevation (meters)	Surf.Area (sq-meters)	Inc.Store (cubic-meters)	Cum.Store (cubic-meters)	Wet.Area (sq-meters)
100.000	0.0	0.0	0.0	0.0
100.150	90.7	4.5	4.5	90.7

Device	Routing	Invert	Outlet Devices
#1	Primary	100.000 m	WATTS Accutrol_5-Closed X 4.00 Head (meters) 0.000 0.025 0.051 0.076 0.102 0.127 0.152 Disch. (m ³ /s) 0.00000 0.00031 0.00031 0.00031 0.00031 0.00031 0.00031 0.00031

Primary OutFlow Max=0.0012 m³/s @ 0.03 hrs HW=100.026 m (Free Discharge)
 ↳1=WATTS Accutrol_5-Closed (Custom Controls 0.0012 m³/s)

112MontrealRd_100 year

Prepared by WSP Canada inc.

HydroCAD® 10.00-22 s/n 10697 © 2018 HydroCAD Software Solutions LLC

Ottawa 100-Year Duration=11 min, Inten=169.9 mm/hr

Printed 2023-03-03

Page 12

Pond 17P: Tower B1 Rooftop Storage

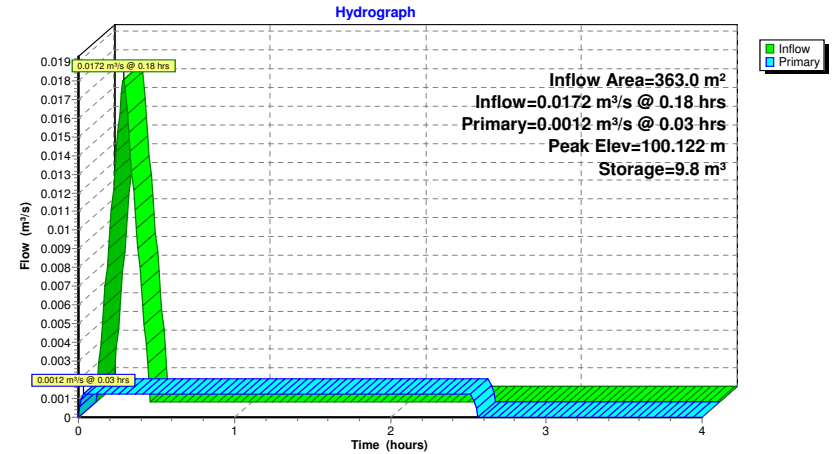

Summary for Pond 25P: Cistern

Inflow Area = 11,960.0 m², Inflow Depth = 30 mm for 100-Year event
 Inflow = 0.5129 m³/s @ 0.18 hrs, Volume= 355.7 m³
 Outflow = 0.1115 m³/s @ 0.54 hrs, Volume= 350.0 m³, Atten= 78%, Lag= 21.9 min
 Primary = 0.1115 m³/s @ 0.54 hrs, Volume= 350.0 m³
 Secondary = 0.0000 m³/s @ 0.00 hrs, Volume= 0.0 m³

Routing by Stor-Ind method, Time Span= 0.00-4.00 hrs, dt= 0.01 hrs
 Peak Elev= 55.237 m @ 0.32 hrs Surf.Area= 0.0 m² Storage= 250.6 m³

Plug-Flow detention time= 28.7 min calculated for 350.0 m³ (98% of inflow)
 Center-of-Mass det. time= 27.0 min (40.8 - 13.8)

Volume	Invert	Avail.Storage	Storage Description
#1	54.250 m	314.5 m ³	Custom Stage Data Listed below

Elevation (meters)	Cum.Store (cubic-meters)
54.250	0.0
54.280	7.4
54.350	29.3
54.460	58.2
54.560	86.5
54.660	114.3
54.760	141.3
54.860	167.5
54.960	192.5
55.070	216.1
55.170	238.0
55.270	256.9
55.370	272.1
55.470	286.2
55.570	300.4
55.680	314.5

Device	Routing	Invert	Outlet Devices
#1	Primary	54.250 m	SHE-0408-1120-1430-1120_HydroBrake Head (meters) 0.000 0.014 0.029 0.043 0.058 0.072 0.087 0.101 0.116 0.130 0.144 0.159 0.173 0.188 0.202 0.217 0.231 0.246 0.260 0.274 0.289 0.303 0.318 0.332 0.347 0.361 0.376 0.390 0.404 0.419 0.433 0.448 0.462 0.477 0.491 0.506 0.520 0.534 0.549 0.563 0.578 0.592 0.607 0.621 0.636 0.650 0.664 0.679 0.693 0.708 0.722 0.737 0.751 0.766 0.780 0.794 0.809 0.823 0.838 0.852 0.867 0.881 0.896 0.910 0.924 0.939 0.953 0.968 0.982 0.997 1.011 1.026 1.040 1.054 1.069 1.083 1.098 1.112 1.127 1.141 1.156 1.170 1.184 1.199 1.213 1.228 1.242 1.257 1.271 1.286 1.300 1.314 1.329 1.343 1.358 1.372 1.387 1.401 1.416 1.430 1.459 1.487 1.516 1.544 1.573 1.602 1.630 1.659 1.687 1.716 Disch. (m ³ /s) 0.00000 0.00025 0.00099 0.00220 0.00386 0.00596

0.00847	0.01137	0.01465	0.01827	0.02221	0.02646	0.03097
0.03574	0.04072	0.04588	0.05120	0.05663	0.06214	0.06769
0.07323	0.07874	0.08430	0.08953	0.09447	0.09917	0.10365
0.10677	0.10741	0.10800	0.10853	0.10901	0.10944	0.10982
0.11016	0.11045	0.11070	0.11092	0.11109	0.11123	0.11134
0.11142	0.11146	0.11148	0.11147	0.11144	0.11138	0.11131
0.11121	0.11109	0.11095	0.11080	0.11062	0.11043	0.11022
0.11000	0.10976	0.10950	0.10923	0.10893	0.10862	0.10829
0.10793	0.10755	0.10715	0.10672	0.10626	0.10577	0.10525
0.10469	0.10408	0.10344	0.10275	0.10200	0.10121	0.10035
0.09943	0.09904	0.09966	0.10028	0.10089	0.10150	0.10211
0.10271	0.10331	0.10390	0.10450	0.10508	0.10567	0.10625
0.10683	0.10740	0.10797	0.10854	0.10911	0.10967	0.11023
0.11078	0.11134	0.11189	0.11292	0.11396	0.11500	0.11604
0.11707	0.11811	0.11915	0.12018	0.12122	0.12226	

#2 Secondary 56.480 m *****Overflow Check**
 Head (meters) 0.000 0.010
 Disch. (m³/s) 0.00000 10.00000

Primary OutFlow Max=0.1115 m³/s @ 0.54 hrs HW=54.874 m (Free Discharge)
 ↳1=SHE-0408-1120-1430-1120_HydroBrake (Custom Controls 0.1115 m³/s)

Secondary OutFlow Max=0.0000 m³/s @ 0.00 hrs HW=54.250 m (Free Discharge)
 ↳2=***Overflow Check (Controls 0.0000 m³/s)

Pond 25P: Cistern

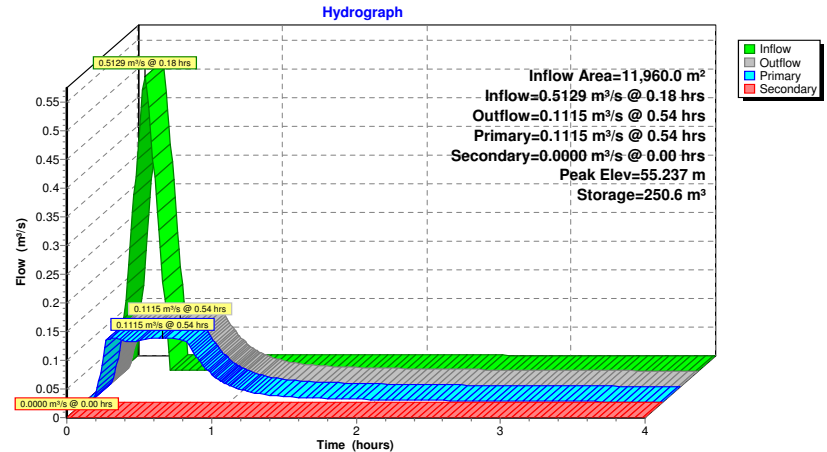

Summary for Link 19L: Site Release

Inflow Area = 12,164.0 m², Inflow Depth > 29 mm for 100-Year event
Inflow = 0.1194 m³/s @ 0.19 hrs, Volume= 355.5 m³
Primary = 0.1194 m³/s @ 0.19 hrs, Volume= 355.5 m³, Atten= 0%, Lag= 0.0 min

Primary outflow = Inflow, Time Span= 0.00-4.00 hrs, dt= 0.01 hrs

Link 19L: Site Release

Hydrograph

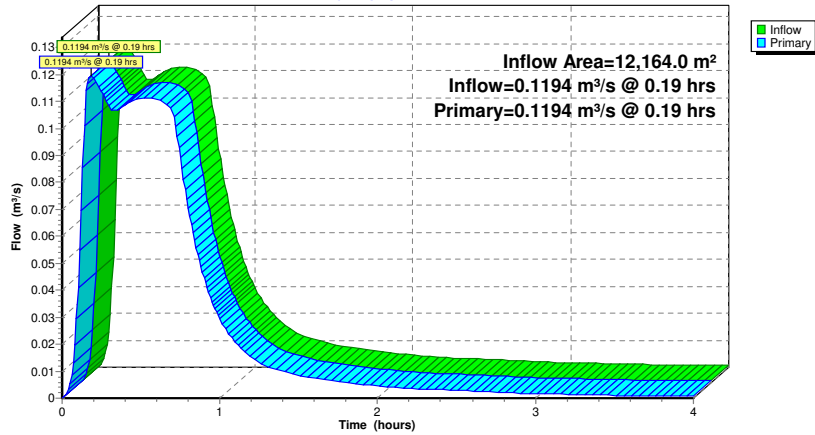

APPENDIX

G-3 *100-YEAR ANALYSIS (PEAK CHAMBER STORAGE)*

112MontrealRd_100 year

Prepared by WSP Canada inc.

HydroCAD® 10.00-22 s/n 10697 © 2018 HydroCAD Software Solutions LLC

Printed 2023-03-03

Page 2

Area Listing (selected nodes)

Area (sq-meters)	C	Description (subcatchment-numbers)
3,790.0	0.89	S03 (9S)
720.0	0.93	S04 (9S)
250.0	0.76	S05 (9S)
5,200.0	1.00	S06 (9S)
690.0	1.00	S07 (9S)
105.0	1.00	S08 (14S)
99.0	0.72	S09 (14S)
500.0	1.00	Tower A (10S, 11S)
810.0	1.00	Tower B1 (10S, 12S)
12,164.0	0.95	TOTAL AREA

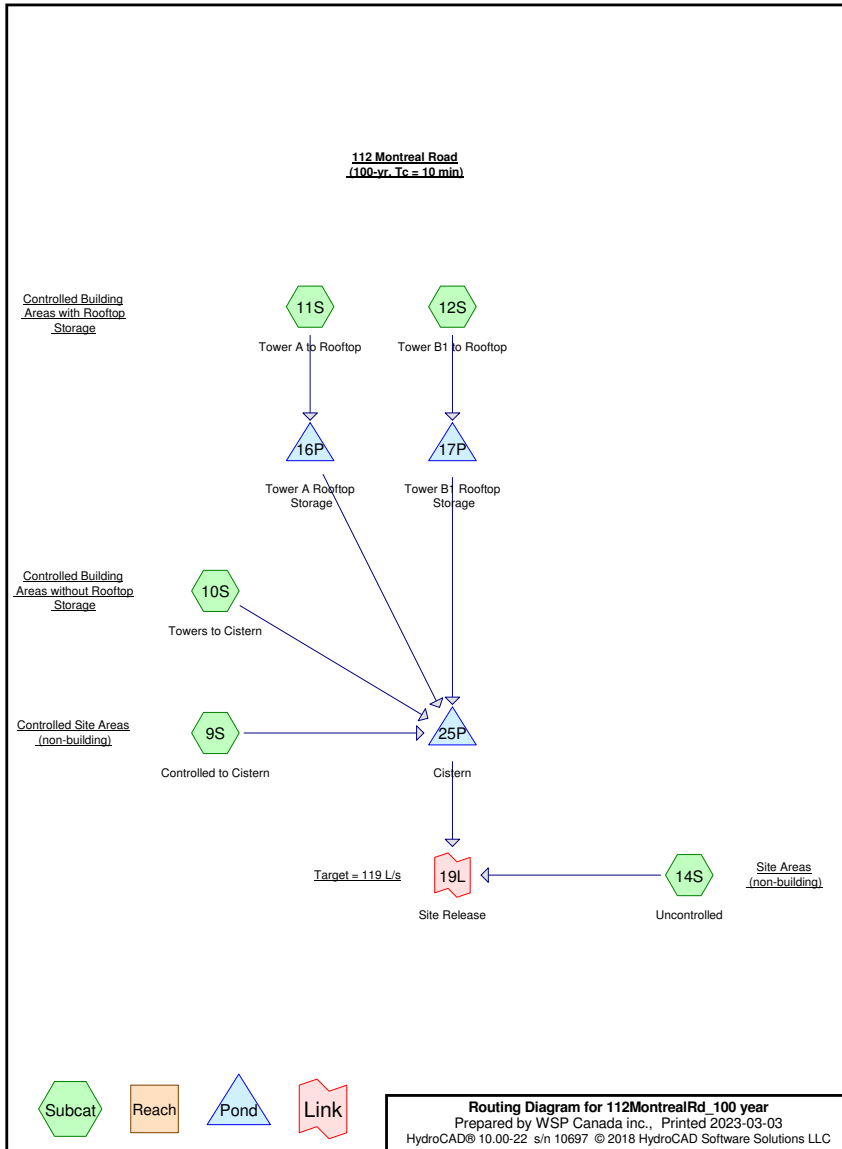

112MontrealRd_100 year

Prepared by WSP Canada inc.

HydroCAD® 10.00-22 s/n 10697 © 2018 HydroCAD Software Solutions LLC

Ottawa 100-Year Duration=30 min, Inten=91.9 mm/hr

Printed 2023-03-03

Page 3

Time span=0.00-4.00 hrs, dt=0.01 hrs, 401 points

Runoff by Rational method, Rise/Fall=1.0/1.0 xTc

Reach routing by Stor-Ind+Trans method - Pond routing by Stor-Ind method

Subcatchment 9S: Controlled to Cistern

Runoff Area=10,650.0 m² Runoff Depth=44 mm
Tc=10.0 min C=0.95 Runoff=0.2582 m³/s 464.7 m³

Subcatchment 10S: Towers to Cistern

Runoff Area=637.0 m² Runoff Depth=46 mm
Tc=10.0 min C=1.00 Runoff=0.0163 m³/s 29.3 m³

Subcatchment 11S: Tower A to Rooftop

Runoff Area=310.0 m² Runoff Depth=46 mm
Tc=10.0 min C=1.00 Runoff=0.0079 m³/s 14.2 m³

Subcatchment 12S: Tower B1 to Rooftop

Runoff Area=363.0 m² Runoff Depth=46 mm
Tc=10.0 min C=1.00 Runoff=0.0093 m³/s 16.7 m³

Subcatchment 14S: Uncontrolled

Runoff Area=204.0 m² Runoff Depth=40 mm
Tc=10.0 min C=0.86 Runoff=0.0045 m³/s 8.1 m³

Pond 16P: Tower A Rooftop Storage Peak Elev=100.084 m Storage=11.0 m³ Inflow=0.0079 m³/s 14.2 m³
Outflow=0.0015 m³/s 14.2 m³

Pond 17P: Tower B1 Rooftop Storage Peak Elev=100.137 m Storage=13.8 m³ Inflow=0.0093 m³/s 16.7 m³
Outflow=0.0012 m³/s 16.7 m³

Pond 25P: Cistern Peak Elev=55.660 m Storage=311.9 m³ Inflow=0.2772 m³/s 524.9 m³
Primary=0.1115 m³/s 515.7 m³ Secondary=0.0000 m³/s 0.0 m³ Outflow=0.1115 m³/s 515.7 m³

Link 19L: Site Release Inflow=0.1160 m³/s 523.8 m³
Primary=0.1160 m³/s 523.8 m³

Total Runoff Area = 12,164.0 m² Runoff Volume = 533.0 m³ Average Runoff Depth = 44 mm

112MontrealRd_100 year

Prepared by WSP Canada inc.

HydroCAD® 10.00-22 s/n 10697 © 2018 HydroCAD Software Solutions LLC

Ottawa 100-Year Duration=30 min, Inten=91.9 mm/hr

Printed 2023-03-03

Page 4

Summary for Subcatchment 9S: Controlled to Cistern

Runoff = 0.2582 m³/s @ 0.17 hrs, Volume= 464.7 m³, Depth= 44 mm

Runoff by Rational method, Rise/Fall=1.0/1.0 xTc, Time Span= 0.00-4.00 hrs, dt= 0.01 hrs
Ottawa 100-Year Duration=30 min, Inten=91.9 mm/hr

Area (m ²)	C	Description
3,790.0	0.89	S03
5,200.0	1.00	S06
720.0	0.93	S04
250.0	0.76	S05
690.0	1.00	S07
10,650.0	0.95	Weighted Average

Tc (min)	Length (meters)	Slope (m/m)	Velocity (m/sec)	Capacity (m ³ /s)	Description
10.0					Direct Entry,

Subcatchment 9S: Controlled to Cistern

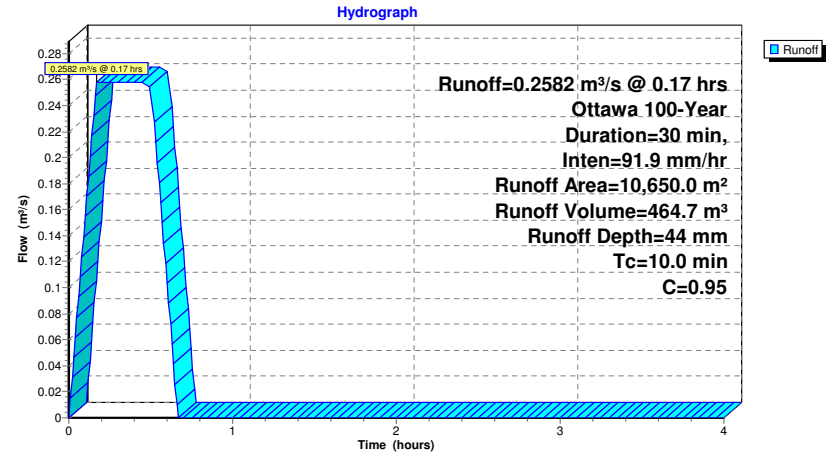

112MontrealRd_100 year

Prepared by WSP Canada inc.

HydroCAD® 10.00-22 s/n 10697 © 2018 HydroCAD Software Solutions LLC

Ottawa 100-Year Duration=30 min, Inten=91.9 mm/hr

Printed 2023-03-03

Page 5

Summary for Subcatchment 10S: Towers to Cistern

Runoff = 0.0163 m³/s @ 0.17 hrs, Volume= 29.3 m³, Depth= 46 mm

Runoff by Rational method, Rise/Fall=1.0/1.0 xTc, Time Span= 0.00-4.00 hrs, dt= 0.01 hrs
 Ottawa 100-Year Duration=30 min, Inten=91.9 mm/hr

Area (m²)	C	Description
190.0	1.00	Tower A
447.0	1.00	Tower B1
637.0	1.00	Weighted Average

Tc (min)	Length (meters)	Slope (m/m)	Velocity (m/sec)	Capacity (m³/s)	Description
10.0					Direct Entry,

Subcatchment 10S: Towers to Cistern

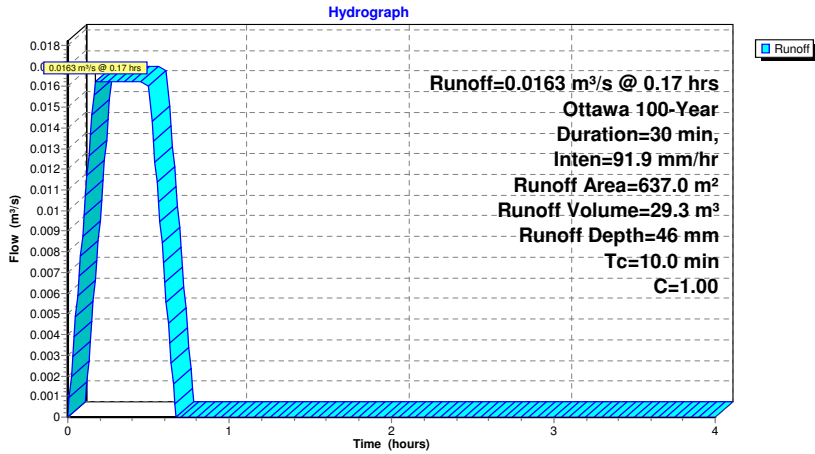

112MontrealRd_100 year

Prepared by WSP Canada inc.

HydroCAD® 10.00-22 s/n 10697 © 2018 HydroCAD Software Solutions LLC

Ottawa 100-Year Duration=30 min, Inten=91.9 mm/hr

Printed 2023-03-03

Page 6

Summary for Subcatchment 11S: Tower A to Rooftop

Runoff = 0.0079 m³/s @ 0.17 hrs, Volume= 14.2 m³, Depth= 46 mm

Runoff by Rational method, Rise/Fall=1.0/1.0 xTc, Time Span= 0.00-4.00 hrs, dt= 0.01 hrs
 Ottawa 100-Year Duration=30 min, Inten=91.9 mm/hr

Area (m²)	C	Description
310.0	1.00	Tower A

Tc (min)	Length (meters)	Slope (m/m)	Velocity (m/sec)	Capacity (m³/s)	Description
10.0					Direct Entry,

Subcatchment 11S: Tower A to Rooftop

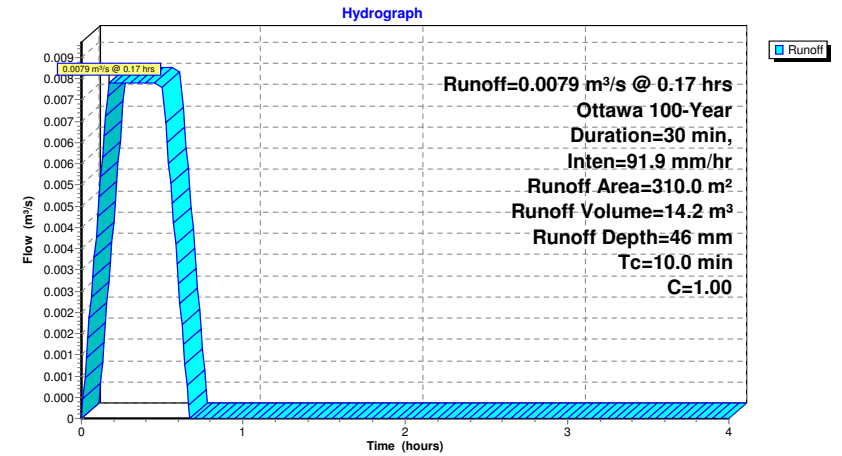

112MontrealRd_100 year

Ottawa 100-Year Duration=30 min, Inten=91.9 mm/hr

Prepared by WSP Canada inc.

Printed 2023-03-03

HydroCAD® 10.00-22 s/n 10697 © 2018 HydroCAD Software Solutions LLC

Page 7

Summary for Subcatchment 12S: Tower B1 to Rooftop

Runoff = 0.0093 m³/s @ 0.17 hrs, Volume= 16.7 m³, Depth= 46 mm

Runoff by Rational method, Rise/Fall=1.0/1.0 xTc, Time Span= 0.00-4.00 hrs, dt= 0.01 hrs
Ottawa 100-Year Duration=30 min, Inten=91.9 mm/hr

Area (m²)	C	Description
363.0	1.00	Tower B1

Tc (min)	Length (meters)	Slope (m/m)	Velocity (m/sec)	Capacity (m³/s)	Description
10.0					Direct Entry,

Subcatchment 12S: Tower B1 to Rooftop

Hydrograph

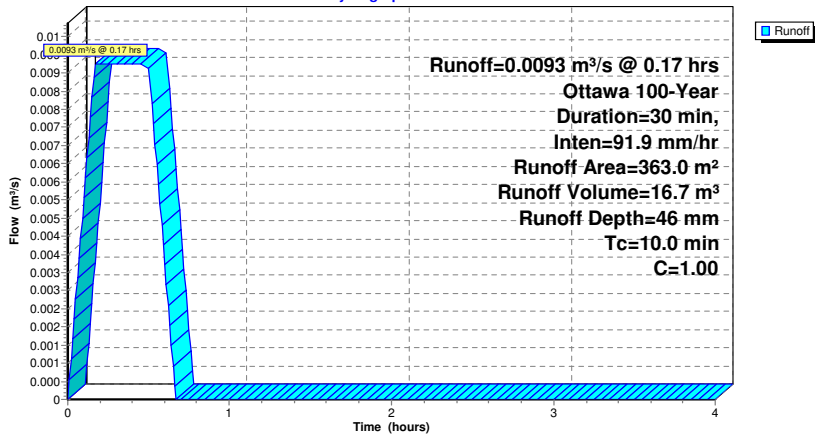

112MontrealRd_100 year

Ottawa 100-Year Duration=30 min, Inten=91.9 mm/hr

Prepared by WSP Canada inc.

Printed 2023-03-03

HydroCAD® 10.00-22 s/n 10697 © 2018 HydroCAD Software Solutions LLC

Page 8

Summary for Subcatchment 14S: Uncontrolled

Runoff = 0.0045 m³/s @ 0.17 hrs, Volume= 8.1 m³, Depth= 40 mm

Runoff by Rational method, Rise/Fall=1.0/1.0 xTc, Time Span= 0.00-4.00 hrs, dt= 0.01 hrs
Ottawa 100-Year Duration=30 min, Inten=91.9 mm/hr

Area (m²)	C	Description
99.0	0.72	S09
105.0	1.00	S08
204.0	0.86	Weighted Average

Tc (min)	Length (meters)	Slope (m/m)	Velocity (m/sec)	Capacity (m³/s)	Description
10.0					Direct Entry,

Subcatchment 14S: Uncontrolled

Hydrograph

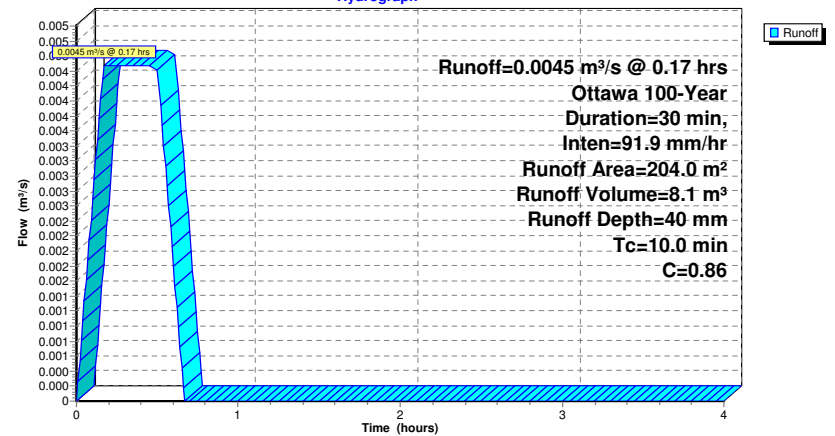

112MontrealRd_100 year

Prepared by WSP Canada inc.

HydroCAD® 10.00-22 s/n 10697 © 2018 HydroCAD Software Solutions LLC

Ottawa 100-Year Duration=30 min, Inten=91.9 mm/hr

Printed 2023-03-03

Page 9

Summary for Pond 16P: Tower A Rooftop Storage

Inflow Area = 310.0 m², Inflow Depth = 46 mm for 100-Year event
 Inflow = 0.0079 m³/s @ 0.17 hrs, Volume= 14.2 m³
 Outflow = 0.0015 m³/s @ 0.13 hrs, Volume= 14.2 m³, Atten= 80%, Lag= 0.0 min
 Primary = 0.0015 m³/s @ 0.13 hrs, Volume= 14.2 m³

Routing by Stor-Ind method, Time Span= 0.00-4.00 hrs, dt= 0.01 hrs
 Peak Elev= 100.084 m @ 0.63 hrs Surf.Area= 260.6 m² Storage= 11.0 m³

Plug-Flow detention time= 60.2 min calculated for 14.2 m³ (100% of inflow)
 Center-of-Mass det. time= 60.4 min (80.4 - 20.0)

Volume	Invert	Avail.Storage	Storage Description
#1	100.000 m	15.5 m ³	Custom Stage Data (Prismatic) Listed below (Recalc) x 5

Elevation (meters)	Surf.Area (sq-meters)	Inc.Store (cubic-meters)	Cum.Store (cubic-meters)
100.000	0.0	0.0	0.0
100.100	62.0	3.1	3.1

Device	Routing	Invert	Outlet Devices
#1	Primary	100.000 m	WATTS Accutrol_5-Closed X 5.00 Head (meters) 0.000 0.025 0.051 0.076 0.102 0.127 0.152 Disch. (m ³ /s) 0.00000 0.00031 0.00031 0.00031 0.00031 0.00031 0.00031 0.00031

Primary OutFlow Max=0.0015 m³/s @ 0.13 hrs HW=100.026 m (Free Discharge)
 ↳1=WATTS Accutrol_5-Closed (Custom Controls 0.0015 m³/s)

112MontrealRd_100 year

Prepared by WSP Canada inc.

HydroCAD® 10.00-22 s/n 10697 © 2018 HydroCAD Software Solutions LLC

Ottawa 100-Year Duration=30 min, Inten=91.9 mm/hr

Printed 2023-03-03

Page 10

Pond 16P: Tower A Rooftop Storage

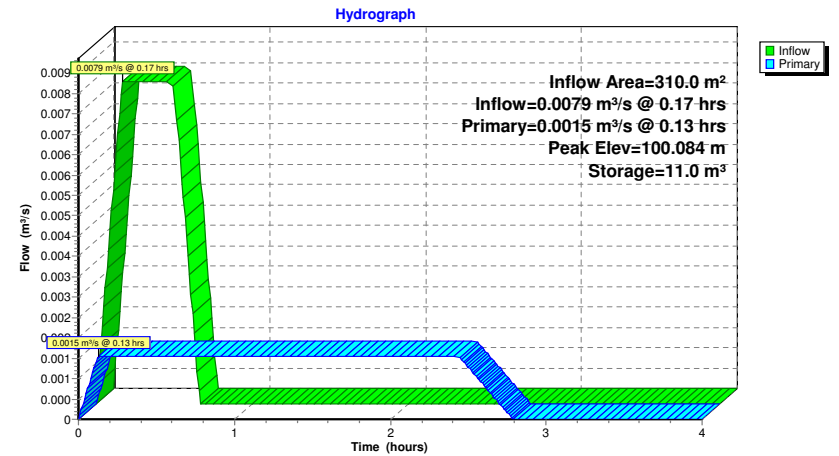

112MontrealRd_100 year

Prepared by WSP Canada inc.

HydroCAD® 10.00-22 s/n 10697 © 2018 HydroCAD Software Solutions LLC

Ottawa 100-Year Duration=30 min, Inten=91.9 mm/hr

Printed 2023-03-03

Page 11

Summary for Pond 17P: Tower B1 Rooftop Storage

Inflow Area = 363.0 m², Inflow Depth = 46 mm for 100-Year event
 Inflow = 0.0093 m³/s @ 0.17 hrs, Volume= 16.7 m³
 Outflow = 0.0012 m³/s @ 0.05 hrs, Volume= 16.7 m³, Atten= 87%, Lag= 0.0 min
 Primary = 0.0012 m³/s @ 0.05 hrs, Volume= 16.7 m³

Routing by Stor-Ind method, Time Span= 0.00-4.00 hrs, dt= 0.01 hrs
 Peak Elev= 100.137 m @ 0.64 hrs Surf.Area= 302.8 m² Storage= 13.8 m³

Plug-Flow detention time= 93.0 min calculated for 16.6 m³ (100% of inflow)
 Center-of-Mass det. time= 93.3 min (113.3 - 20.0)

Volume	Invert	Avail.Storage	Storage Description
#1	100.000 m	18.1 m ³	Custom Stage Data (Pyramidal) Listed below (Recalc) x 4

Elevation (meters)	Surf.Area (sq-meters)	Inc.Store (cubic-meters)	Cum.Store (cubic-meters)	Wet.Area (sq-meters)
100.000	0.0	0.0	0.0	0.0
100.150	90.7	4.5	4.5	90.7

Device	Routing	Invert	Outlet Devices
#1	Primary	100.000 m	WATTS Accutrol_5-Closed X 4.00 Head (meters) 0.000 0.025 0.051 0.076 0.102 0.127 0.152 Disch. (m ³ /s) 0.00000 0.00031 0.00031 0.00031 0.00031 0.00031 0.00031 0.00031

Primary OutFlow Max=0.0012 m³/s @ 0.05 hrs HW=100.028 m (Free Discharge)
 1=WATTS Accutrol_5-Closed (Custom Controls 0.0012 m³/s)

112MontrealRd_100 year

Prepared by WSP Canada inc.

HydroCAD® 10.00-22 s/n 10697 © 2018 HydroCAD Software Solutions LLC

Ottawa 100-Year Duration=30 min, Inten=91.9 mm/hr

Printed 2023-03-03

Page 12

Pond 17P: Tower B1 Rooftop Storage

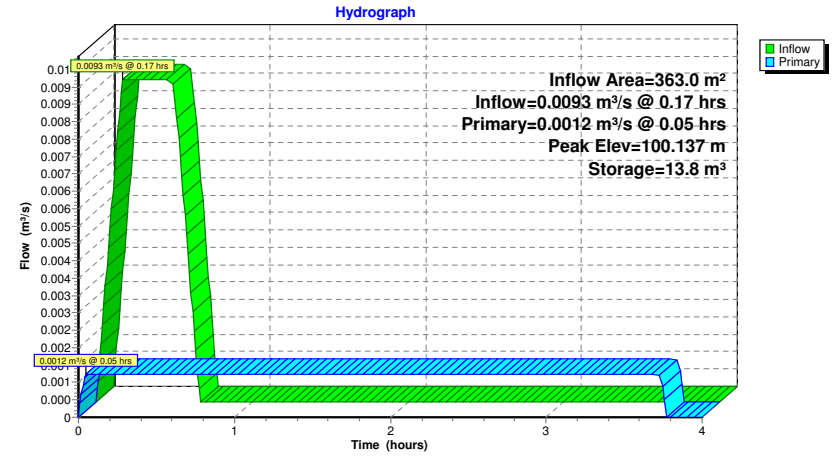

Summary for Pond 25P: Cistern

Inflow Area = 11,960.0 m², Inflow Depth = 44 mm for 100-Year event
 Inflow = 0.2772 m³/s @ 0.17 hrs, Volume= 524.9 m³
 Outflow = 0.1115 m³/s @ 0.32 hrs, Volume= 515.7 m³, Atten= 60%, Lag= 9.0 min
 Primary = 0.1115 m³/s @ 0.32 hrs, Volume= 515.7 m³
 Secondary = 0.0000 m³/s @ 0.00 hrs, Volume= 0.0 m³

Routing by Stor-Ind method, Time Span= 0.00-4.00 hrs, dt= 0.01 hrs
 Peak Elev= 55.660 m @ 0.60 hrs Surf.Area= 0.0 m² Storage= 311.9 m³

Plug-Flow detention time= 31.9 min calculated for 514.4 m³ (98% of inflow)
 Center-of-Mass det. time= 29.5 min (54.1 - 24.6)

Volume	Invert	Avail.Storage	Storage Description
#1	54.250 m	314.5 m ³	Custom Stage Data Listed below

Elevation (meters)	Cum.Store (cubic-meters)
54.250	0.0
54.280	7.4
54.350	29.3
54.460	58.2
54.560	86.5
54.660	114.3
54.760	141.3
54.860	167.5
54.960	192.5
55.070	216.1
55.170	238.0
55.270	256.9
55.370	272.1
55.470	286.2
55.570	300.4
55.680	314.5

Device	Routing	Invert	Outlet Devices
#1	Primary	54.250 m	SHE-0408-1120-1430-1120_HydroBrake Head (meters) 0.000 0.014 0.029 0.043 0.058 0.072 0.087 0.101 0.116 0.130 0.144 0.159 0.173 0.188 0.202 0.217 0.231 0.246 0.260 0.274 0.289 0.303 0.318 0.332 0.347 0.361 0.376 0.390 0.404 0.419 0.433 0.448 0.462 0.477 0.491 0.506 0.520 0.534 0.549 0.563 0.578 0.592 0.607 0.621 0.636 0.650 0.664 0.679 0.693 0.708 0.722 0.737 0.751 0.766 0.780 0.794 0.809 0.823 0.838 0.852 0.867 0.881 0.896 0.910 0.924 0.939 0.953 0.968 0.982 0.997 1.011 1.026 1.040 1.054 1.069 1.083 1.098 1.112 1.127 1.141 1.156 1.170 1.184 1.199 1.213 1.228 1.242 1.257 1.271 1.286 1.300 1.314 1.329 1.343 1.358 1.372 1.387 1.401 1.416 1.430 1.459 1.487 1.516 1.544 1.573 1.602 1.630 1.659 1.687 1.716 Disch. (m ³ /s) 0.00000 0.00025 0.00099 0.00220 0.00386 0.00596

0.00847	0.01137	0.01465	0.01827	0.02221	0.02646	0.03097
0.03574	0.04072	0.04588	0.05120	0.05663	0.06214	0.06769
0.07323	0.07874	0.08430	0.08953	0.09447	0.09917	0.10365
0.10677	0.10741	0.10800	0.10853	0.10901	0.10944	0.10982
0.11016	0.11045	0.11070	0.11092	0.11109	0.11123	0.11134
0.11142	0.11146	0.11148	0.11147	0.11144	0.11138	0.11131
0.11121	0.11109	0.11095	0.11080	0.11062	0.11043	0.11022
0.11000	0.10976	0.10950	0.10923	0.10893	0.10862	0.10829
0.10793	0.10755	0.10715	0.10672	0.10626	0.10577	0.10525
0.10469	0.10408	0.10344	0.10275	0.10200	0.10121	0.10035
0.09943	0.09904	0.09966	0.10028	0.10089	0.10150	0.10211
0.10271	0.10331	0.10390	0.10450	0.10508	0.10567	0.10625
0.10683	0.10740	0.10797	0.10854	0.10911	0.10967	0.11023
0.11078	0.11134	0.11189	0.11292	0.11396	0.11500	0.11604
0.11707	0.11811	0.11915	0.12018	0.12122	0.12226	

#2 Secondary 56.480 m *****Overflow Check**
 Head (meters) 0.000 0.010
 Disch. (m³/s) 0.00000 10.00000

Primary OutFlow Max=0.1115 m³/s @ 0.32 hrs HW=54.874 m (Free Discharge)
 #1=SHE-0408-1120-1430-1120_HydroBrake (Custom Controls 0.1115 m³/s)

Secondary OutFlow Max=0.0000 m³/s @ 0.00 hrs HW=54.250 m (Free Discharge)
 #2=***Overflow Check (Controls 0.0000 m³/s)

Pond 25P: Cistern

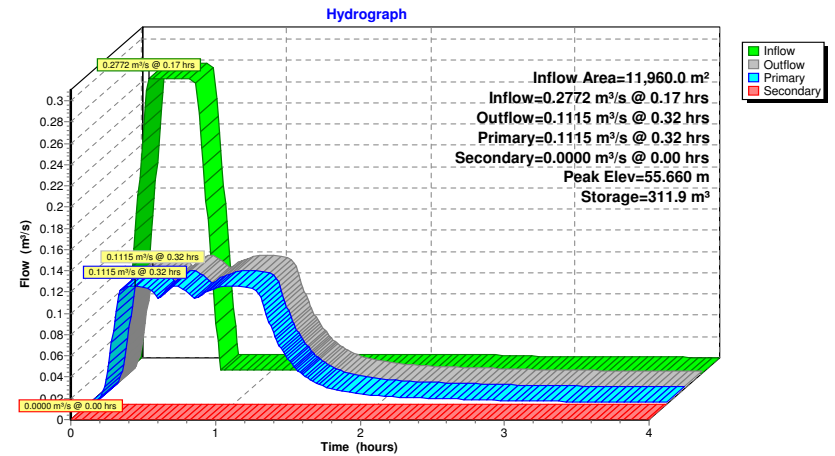

Summary for Link 19L: Site Release

Inflow Area = 12,164.0 m², Inflow Depth > 43 mm for 100-Year event
Inflow = 0.1160 m³/s @ 0.32 hrs, Volume= 523.8 m³
Primary = 0.1160 m³/s @ 0.32 hrs, Volume= 523.8 m³, Atten= 0%, Lag= 0.0 min

Primary outflow = Inflow, Time Span= 0.00-4.00 hrs, dt= 0.01 hrs

Link 19L: Site Release

Hydrograph

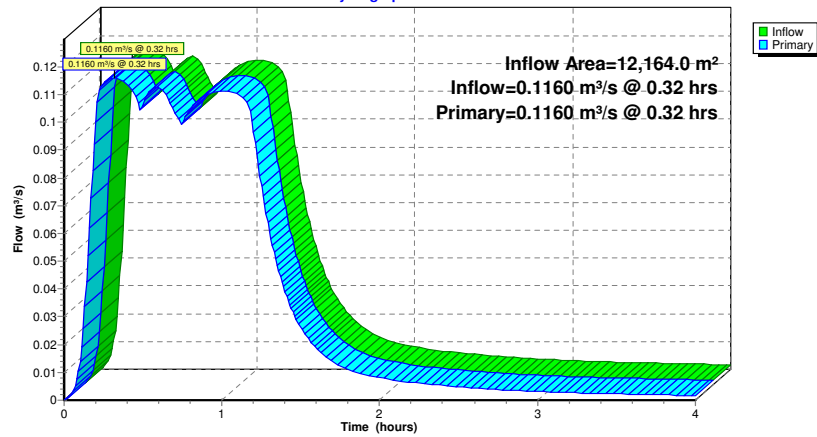

APPENDIX

G-4 *100-YEAR ANALYSIS (PEAK ROOF STORAGE)*

112MontrealRd_100 year

Prepared by WSP Canada inc.

HydroCAD® 10.00-22 s/n 10697 © 2018 HydroCAD Software Solutions LLC

Printed 2023-03-03

Page 2

Area Listing (selected nodes)

Area (sq-meters)	C	Description (subcatchment-numbers)
3,790.0	0.89	S03 (9S)
720.0	0.93	S04 (9S)
250.0	0.76	S05 (9S)
5,200.0	1.00	S06 (9S)
690.0	1.00	S07 (9S)
105.0	1.00	S08 (14S)
99.0	0.72	S09 (14S)
500.0	1.00	Tower A (10S, 11S)
810.0	1.00	Tower B1 (10S, 12S)
12,164.0	0.95	TOTAL AREA

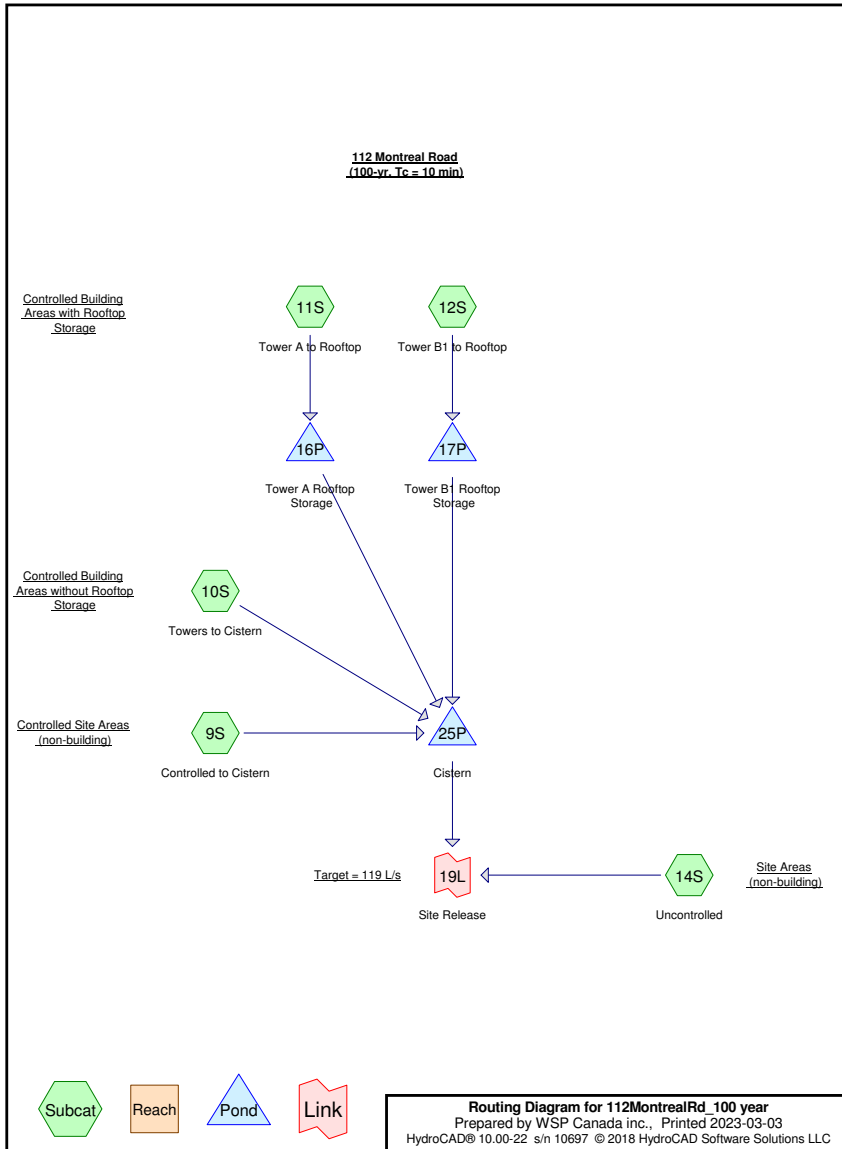

112MontrealRd_100 year

Prepared by WSP Canada inc.

HydroCAD® 10.00-22 s/n 10697 © 2018 HydroCAD Software Solutions LLC

Ottawa 100-Year Duration=51 min, Inten=63.0 mm/hr

Printed 2023-03-03

Page 3

Time span=0.00-4.00 hrs, dt=0.01 hrs, 401 points

Runoff by Rational method, Rise/Fall=1.0/1.0 xTc

Reach routing by Stor-Ind+Trans method - Pond routing by Stor-Ind method

Subcatchment 9S: Controlled to CisternRunoff Area=10,650.0 m² Runoff Depth=51 mm
Tc=10.0 min C=0.95 Runoff=0.1771 m³/s 542.1 m³**Subcatchment 10S: Towers to Cistern**Runoff Area=637.0 m² Runoff Depth=54 mm
Tc=10.0 min C=1.00 Runoff=0.0112 m³/s 34.1 m³**Subcatchment 11S: Tower A to Rooftop**Runoff Area=310.0 m² Runoff Depth=54 mm
Tc=10.0 min C=1.00 Runoff=0.0054 m³/s 16.6 m³**Subcatchment 12S: Tower B1 to Rooftop**Runoff Area=363.0 m² Runoff Depth=54 mm
Tc=10.0 min C=1.00 Runoff=0.0064 m³/s 19.4 m³**Subcatchment 14S: Uncontrolled**Runoff Area=204.0 m² Runoff Depth=46 mm
Tc=10.0 min C=0.86 Runoff=0.0031 m³/s 9.4 m³**Pond 16P: Tower A Rooftop Storage** Peak Elev=100.086 m Storage=11.5 m³ Inflow=0.0054 m³/s 16.6 m³
Outflow=0.0015 m³/s 16.6 m³**Pond 17P: Tower B1 Rooftop Storage** Peak Elev=100.141 m Storage=15.1 m³ Inflow=0.0064 m³/s 19.4 m³
Outflow=0.0012 m³/s 17.8 m³**Pond 25P: Cistern** Peak Elev=55.451 m Storage=283.5 m³ Inflow=0.1911 m³/s 610.6 m³
Primary=0.1115 m³/s 599.5 m³ Secondary=0.0000 m³/s 0.0 m³ Outflow=0.1115 m³/s 599.5 m³**Link 19L: Site Release** Inflow=0.1145 m³/s 608.9 m³
Primary=0.1145 m³/s 608.9 m³**Total Runoff Area = 12,164.0 m² Runoff Volume = 621.7 m³ Average Runoff Depth = 51 mm****112MontrealRd_100 year**

Prepared by WSP Canada inc.

HydroCAD® 10.00-22 s/n 10697 © 2018 HydroCAD Software Solutions LLC

Ottawa 100-Year Duration=51 min, Inten=63.0 mm/hr

Printed 2023-03-03

Page 4

Summary for Subcatchment 9S: Controlled to CisternRunoff = 0.1771 m³/s @ 0.17 hrs, Volume= 542.1 m³, Depth= 51 mmRunoff by Rational method, Rise/Fall=1.0/1.0 xTc, Time Span= 0.00-4.00 hrs, dt= 0.01 hrs
Ottawa 100-Year Duration=51 min, Inten=63.0 mm/hr

Area (m ²)	C	Description
3,790.0	0.89	S03
5,200.0	1.00	S06
720.0	0.93	S04
250.0	0.76	S05
690.0	1.00	S07
10,650.0	0.95	Weighted Average

Tc (min)	Length (meters)	Slope (m/m)	Velocity (m/sec)	Capacity (m ³ /s)	Description
10.0					Direct Entry,

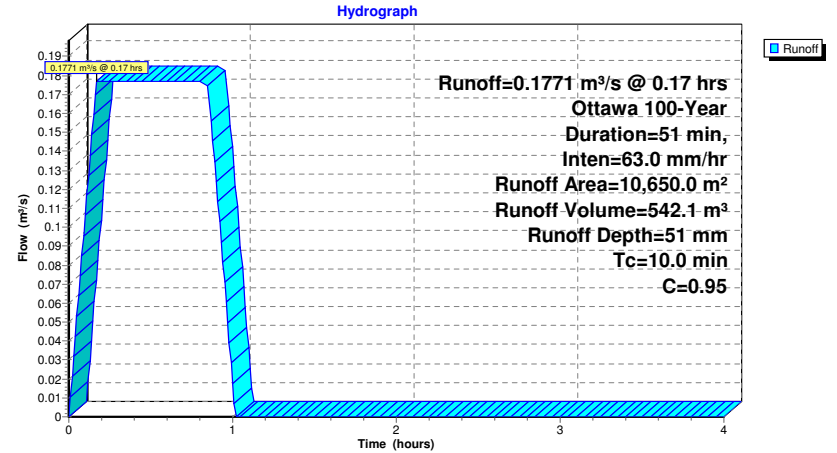
Subcatchment 9S: Controlled to Cistern

112MontrealRd_100 year

Prepared by WSP Canada inc.

HydroCAD® 10.00-22 s/n 10697 © 2018 HydroCAD Software Solutions LLC

Ottawa 100-Year Duration=51 min, Inten=63.0 mm/hr

Printed 2023-03-03

Page 5

Summary for Subcatchment 10S: Towers to Cistern

Runoff = 0.0112 m³/s @ 0.17 hrs, Volume= 34.1 m³, Depth= 54 mm

Runoff by Rational method, Rise/Fall=1.0/1.0 xTc, Time Span= 0.00-4.00 hrs, dt= 0.01 hrs
 Ottawa 100-Year Duration=51 min, Inten=63.0 mm/hr

Area (m²)	C	Description
190.0	1.00	Tower A
447.0	1.00	Tower B1
637.0	1.00	Weighted Average

Tc (min)	Length (meters)	Slope (m/m)	Velocity (m/sec)	Capacity (m³/s)	Description
10.0					Direct Entry,

Subcatchment 10S: Towers to Cistern

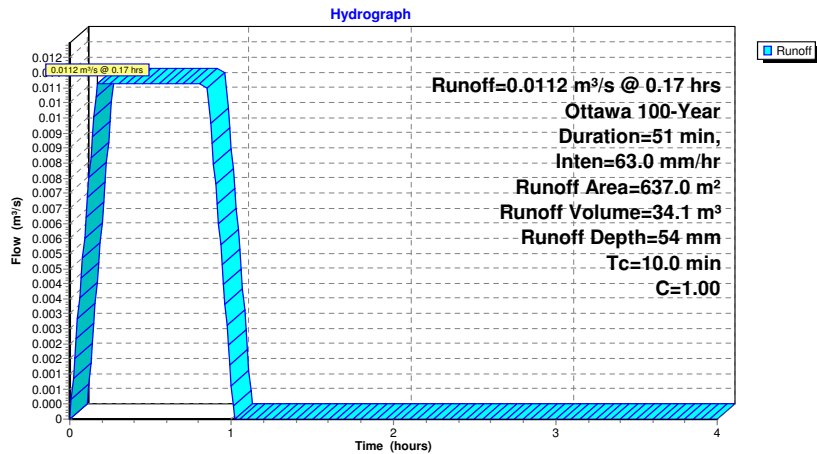

112MontrealRd_100 year

Prepared by WSP Canada inc.

HydroCAD® 10.00-22 s/n 10697 © 2018 HydroCAD Software Solutions LLC

Ottawa 100-Year Duration=51 min, Inten=63.0 mm/hr

Printed 2023-03-03

Page 6

Summary for Subcatchment 11S: Tower A to Rooftop

Runoff = 0.0054 m³/s @ 0.17 hrs, Volume= 16.6 m³, Depth= 54 mm

Runoff by Rational method, Rise/Fall=1.0/1.0 xTc, Time Span= 0.00-4.00 hrs, dt= 0.01 hrs
 Ottawa 100-Year Duration=51 min, Inten=63.0 mm/hr

Area (m²)	C	Description
310.0	1.00	Tower A

Tc (min)	Length (meters)	Slope (m/m)	Velocity (m/sec)	Capacity (m³/s)	Description
10.0					Direct Entry,

Subcatchment 11S: Tower A to Rooftop

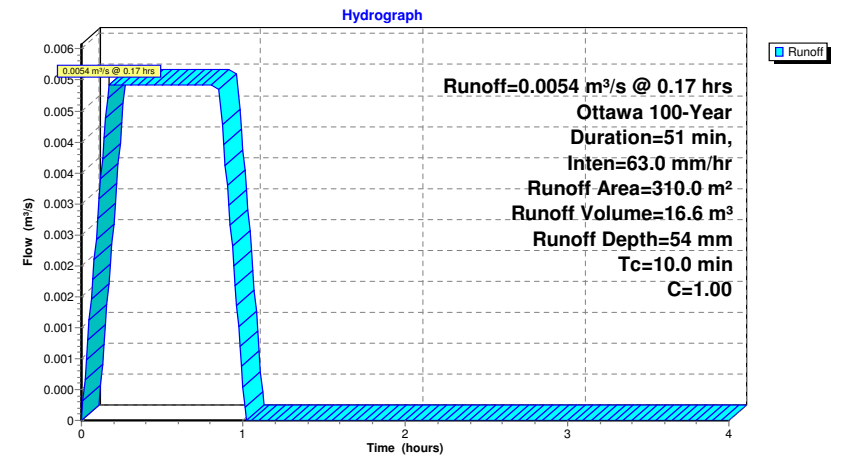

112MontrealRd_100 year

Ottawa 100-Year Duration=51 min, Inten=63.0 mm/hr

Prepared by WSP Canada inc.

Printed 2023-03-03

HydroCAD® 10.00-22 s/n 10697 © 2018 HydroCAD Software Solutions LLC

Page 7

Summary for Subcatchment 12S: Tower B1 to Rooftop

Runoff = 0.0064 m³/s @ 0.17 hrs, Volume= 19.4 m³, Depth= 54 mm

Runoff by Rational method, Rise/Fall=1.0/1.0 xTc, Time Span= 0.00-4.00 hrs, dt= 0.01 hrs
Ottawa 100-Year Duration=51 min, Inten=63.0 mm/hr

Area (m²)	C	Description
363.0	1.00	Tower B1

Tc (min)	Length (meters)	Slope (m/m)	Velocity (m/sec)	Capacity (m³/s)	Description
10.0					Direct Entry,

Subcatchment 12S: Tower B1 to Rooftop

Hydrograph

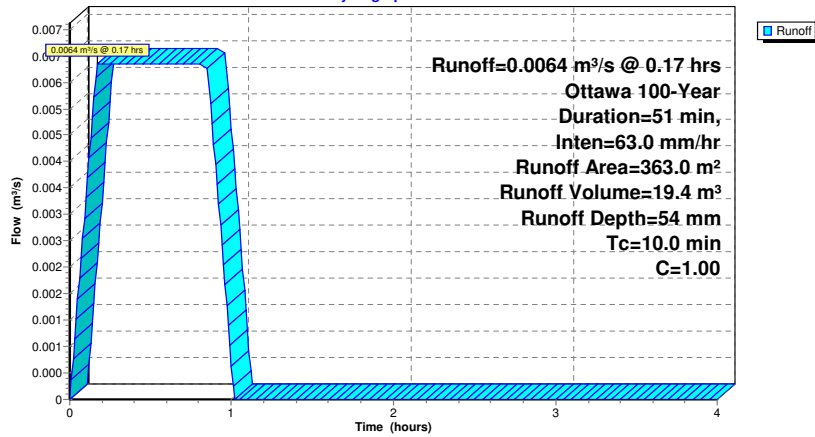

112MontrealRd_100 year

Ottawa 100-Year Duration=51 min, Inten=63.0 mm/hr

Prepared by WSP Canada inc.

Printed 2023-03-03

HydroCAD® 10.00-22 s/n 10697 © 2018 HydroCAD Software Solutions LLC

Page 8

Summary for Subcatchment 14S: Uncontrolled

Runoff = 0.0031 m³/s @ 0.17 hrs, Volume= 9.4 m³, Depth= 46 mm

Runoff by Rational method, Rise/Fall=1.0/1.0 xTc, Time Span= 0.00-4.00 hrs, dt= 0.01 hrs
Ottawa 100-Year Duration=51 min, Inten=63.0 mm/hr

Area (m²)	C	Description
99.0	0.72	S09
105.0	1.00	S08
204.0	0.86	Weighted Average

Tc (min)	Length (meters)	Slope (m/m)	Velocity (m/sec)	Capacity (m³/s)	Description
10.0					Direct Entry,

Subcatchment 14S: Uncontrolled

Hydrograph

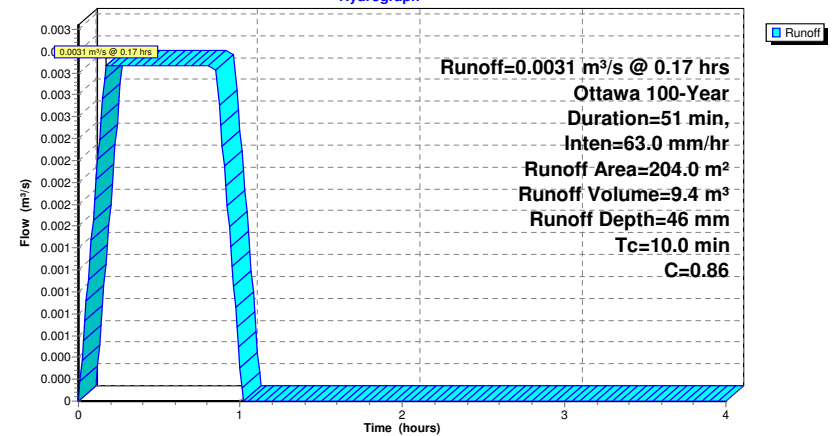

112MontrealRd_100 year

Prepared by WSP Canada inc.

HydroCAD® 10.00-22 s/n 10697 © 2018 HydroCAD Software Solutions LLC

Ottawa 100-Year Duration=51 min, Inten=63.0 mm/hr

Printed 2023-03-03

Page 9

Summary for Pond 16P: Tower A Rooftop Storage

Inflow Area = 310.0 m², Inflow Depth = 54 mm for 100-Year event
 Inflow = 0.0054 m³/s @ 0.17 hrs, Volume= 16.6 m³
 Outflow = 0.0015 m³/s @ 0.16 hrs, Volume= 16.6 m³, Atten= 71%, Lag= 0.0 min
 Primary = 0.0015 m³/s @ 0.16 hrs, Volume= 16.6 m³

Routing by Stor-Ind method, Time Span= 0.00-4.00 hrs, dt= 0.01 hrs
 Peak Elev= 100.086 m @ 0.97 hrs Surf.Area= 267.0 m² Storage= 11.5 m³

Plug-Flow detention time= 63.5 min calculated for 16.6 m³ (100% of inflow)
 Center-of-Mass det. time= 63.5 min (94.0 - 30.5)

Volume	Invert	Avail.Storage	Storage Description
#1	100.000 m	15.5 m ³	Custom Stage Data (Prismatic) Listed below (Recalc) x 5

Elevation (meters)	Surf.Area (sq-meters)	Inc.Store (cubic-meters)	Cum.Store (cubic-meters)
100.000	0.0	0.0	0.0
100.100	62.0	3.1	3.1

Device	Routing	Invert	Outlet Devices
#1	Primary	100.000 m	WATTS Accutrol_5-Closed X 5.00 Head (meters) 0.000 0.025 0.051 0.076 0.102 0.127 0.152 Disch. (m ³ /s) 0.00000 0.00031 0.00031 0.00031 0.00031 0.00031 0.00031 0.00031

Primary OutFlow Max=0.0015 m³/s @ 0.16 hrs HW=100.026 m (Free Discharge)
 ↳1=WATTS Accutrol_5-Closed (Custom Controls 0.0015 m³/s)

112MontrealRd_100 year

Prepared by WSP Canada inc.

HydroCAD® 10.00-22 s/n 10697 © 2018 HydroCAD Software Solutions LLC

Ottawa 100-Year Duration=51 min, Inten=63.0 mm/hr

Printed 2023-03-03

Page 10

Pond 16P: Tower A Rooftop Storage

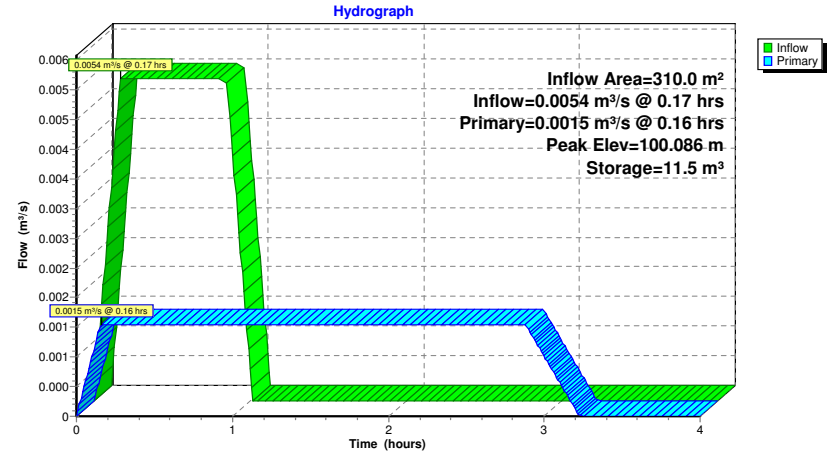

112MontrealRd_100 year

Prepared by WSP Canada inc.

HydroCAD® 10.00-22 s/n 10697 © 2018 HydroCAD Software Solutions LLC

Ottawa 100-Year Duration=51 min, Inten=63.0 mm/hr

Printed 2023-03-03

Page 11

Summary for Pond 17P: Tower B1 Rooftop Storage

Inflow Area = 363.0 m², Inflow Depth = 54 mm for 100-Year event
 Inflow = 0.0064 m³/s @ 0.17 hrs, Volume= 19.4 m³
 Outflow = 0.0012 m³/s @ 0.06 hrs, Volume= 17.8 m³, Atten= 80%, Lag= 0.0 min
 Primary = 0.0012 m³/s @ 0.06 hrs, Volume= 17.8 m³

Routing by Stor-Ind method, Time Span= 0.00-4.00 hrs, dt= 0.01 hrs
 Peak Elev= 100.141 m @ 0.98 hrs Surf.Area= 321.0 m² Storage= 15.1 m³

Plug-Flow detention time= 92.5 min calculated for 17.7 m³ (91% of inflow)
 Center-of-Mass det. time= 90.4 min (120.9 - 30.5)

Volume	Invert	Avail.Storage	Storage Description
#1	100.000 m	18.1 m ³	Custom Stage Data (Pyramidal) Listed below (Recalc) x 4

Elevation (meters)	Surf.Area (sq-meters)	Inc.Store (cubic-meters)	Cum.Store (cubic-meters)	Wet.Area (sq-meters)
100.000	0.0	0.0	0.0	0.0
100.150	90.7	4.5	4.5	90.7

Device	Routing	Invert	Outlet Devices
#1	Primary	100.000 m	WATTS Accutrol_5-Closed X 4.00 Head (meters) 0.000 0.025 0.051 0.076 0.102 0.127 0.152 Disch. (m ³ /s) 0.00000 0.00031 0.00031 0.00031 0.00031 0.00031 0.00031 0.00031

Primary OutFlow Max=0.0012 m³/s @ 0.06 hrs HW=100.026 m (Free Discharge)
 ↳1=WATTS Accutrol_5-Closed (Custom Controls 0.0012 m³/s)

112MontrealRd_100 year

Prepared by WSP Canada inc.

HydroCAD® 10.00-22 s/n 10697 © 2018 HydroCAD Software Solutions LLC

Ottawa 100-Year Duration=51 min, Inten=63.0 mm/hr

Printed 2023-03-03

Page 12

Pond 17P: Tower B1 Rooftop Storage

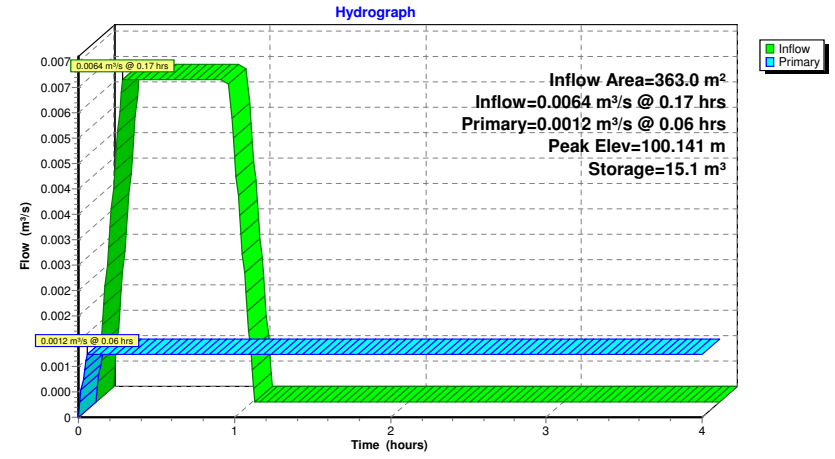

Summary for Pond 25P: Cistern

Inflow Area = 11,960.0 m², Inflow Depth > 51 mm for 100-Year event
 Inflow = 0.1911 m³/s @ 0.17 hrs, Volume= 610.6 m³
 Outflow = 0.1115 m³/s @ 1.27 hrs, Volume= 599.5 m³, Atten= 42%, Lag= 66.1 min
 Primary = 0.1115 m³/s @ 1.27 hrs, Volume= 599.5 m³
 Secondary = 0.0000 m³/s @ 0.00 hrs, Volume= 0.0 m³

Routing by Stor-Ind method, Time Span= 0.00-4.00 hrs, dt= 0.01 hrs
 Peak Elev= 55.451 m @ 0.93 hrs Surf.Area= 0.0 m² Storage= 283.5 m³

Plug-Flow detention time= 29.9 min calculated for 599.5 m³ (98% of inflow)
 Center-of-Mass det. time= 27.2 min (62.1 - 34.9)

Volume	Invert	Avail.Storage	Storage Description
#1	54.250 m	314.5 m ³	Custom Stage Data Listed below

Elevation (meters)	Cum.Store (cubic-meters)
54.250	0.0
54.280	7.4
54.350	29.3
54.460	58.2
54.560	86.5
54.660	114.3
54.760	141.3
54.860	167.5
54.960	192.5
55.070	216.1
55.170	238.0
55.270	256.9
55.370	272.1
55.470	286.2
55.570	300.4
55.680	314.5

Device	Routing	Invert	Outlet Devices
#1	Primary	54.250 m	SHE-0408-1120-1430-1120_HydroBrake Head (meters) 0.000 0.014 0.029 0.043 0.058 0.072 0.087 0.101 0.116 0.130 0.144 0.159 0.173 0.188 0.202 0.217 0.231 0.246 0.260 0.274 0.289 0.303 0.318 0.332 0.347 0.361 0.376 0.390 0.404 0.419 0.433 0.448 0.462 0.477 0.491 0.506 0.520 0.534 0.549 0.563 0.578 0.592 0.607 0.621 0.636 0.650 0.664 0.679 0.693 0.708 0.722 0.737 0.751 0.766 0.780 0.794 0.809 0.823 0.838 0.852 0.867 0.881 0.896 0.910 0.924 0.939 0.953 0.968 0.982 0.997 1.011 1.026 1.040 1.054 1.069 1.083 1.098 1.112 1.127 1.141 1.156 1.170 1.184 1.199 1.213 1.228 1.242 1.257 1.271 1.286 1.300 1.314 1.329 1.343 1.358 1.372 1.387 1.401 1.416 1.430 1.459 1.487 1.516 1.544 1.573 1.602 1.630 1.659 1.687 1.716 Disch. (m ³ /s) 0.00000 0.00025 0.00099 0.00220 0.00386 0.00596

0.00847	0.01137	0.01465	0.01827	0.02221	0.02646	0.03097
0.03574	0.04072	0.04588	0.05120	0.05663	0.06214	0.06769
0.07323	0.07874	0.08430	0.08953	0.09447	0.09917	0.10365
0.10677	0.10741	0.10800	0.10853	0.10901	0.10944	0.10982
0.11016	0.11045	0.11070	0.11092	0.11109	0.11123	0.11134
0.11142	0.11146	0.11148	0.11147	0.11144	0.11138	0.11131
0.11121	0.11109	0.11095	0.11080	0.11062	0.11043	0.11022
0.11000	0.10976	0.10950	0.10923	0.10893	0.10862	0.10829
0.10793	0.10755	0.10715	0.10672	0.10626	0.10577	0.10525
0.10469	0.10408	0.10344	0.10275	0.10200	0.10121	0.10035
0.09943	0.09904	0.09966	0.10028	0.10089	0.10150	0.10211
0.10271	0.10331	0.10390	0.10450	0.10508	0.10567	0.10625
0.10683	0.10740	0.10797	0.10854	0.10911	0.10967	0.11023
0.11078	0.11134	0.11189	0.11292	0.11396	0.11500	0.11604
0.11707	0.11811	0.11915	0.12018	0.12122	0.12226	

#2 Secondary 56.480 m *****Overflow Check**
 Head (meters) 0.000 0.010
 Disch. (m³/s) 0.00000 10.00000

Primary OutFlow Max=0.1115 m³/s @ 1.27 hrs HW=54.874 m (Free Discharge)
 ↳1=SHE-0408-1120-1430-1120_HydroBrake (Custom Controls 0.1115 m³/s)

Secondary OutFlow Max=0.0000 m³/s @ 0.00 hrs HW=54.250 m (Free Discharge)
 ↳2=***Overflow Check (Controls 0.0000 m³/s)

Pond 25P: Cistern

Hydrograph

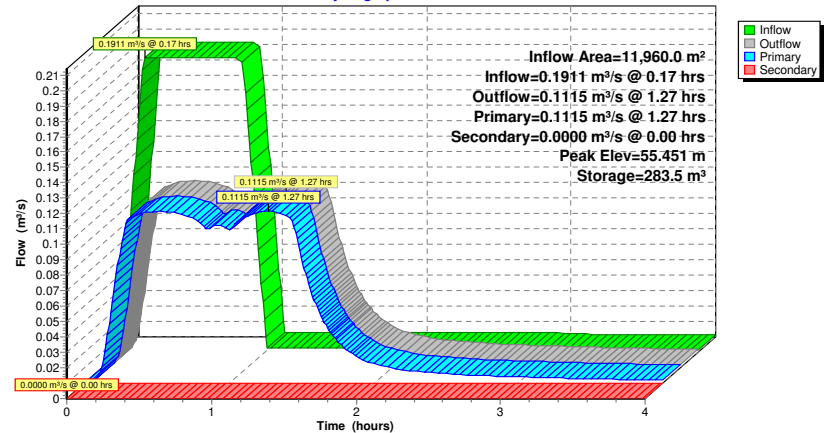

Summary for Link 19L: Site Release

Inflow Area = 12,164.0 m², Inflow Depth > 50 mm for 100-Year event
Inflow = 0.1145 m³/s @ 0.52 hrs, Volume= 608.9 m³
Primary = 0.1145 m³/s @ 0.52 hrs, Volume= 608.9 m³, Atten= 0%, Lag= 0.0 min

Primary outflow = Inflow, Time Span= 0.00-4.00 hrs, dt= 0.01 hrs

Link 19L: Site Release

Hydrograph

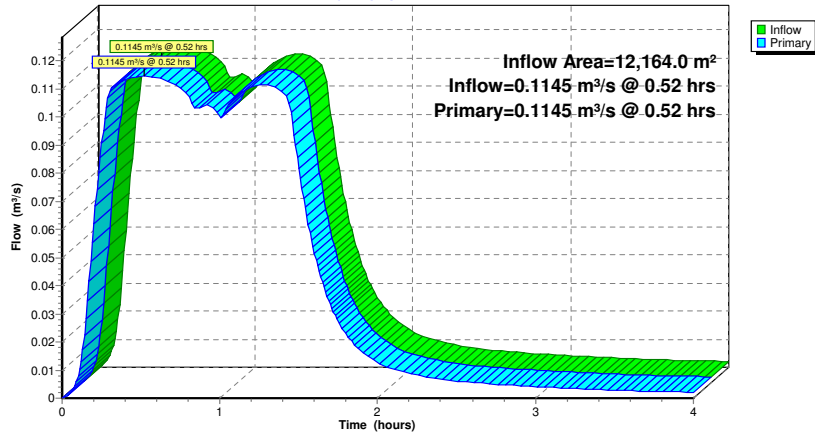

112MontrealRd_100 year

Prepared by WSP Canada inc.

HydroCAD® 10.00-22 s/n 10697 © 2018 HydroCAD Software Solutions LLC

Printed 2023-03-03

Page 2

Area Listing (selected nodes)

Area (sq-meters)	C	Description (subcatchment-numbers)
3,790.0	0.89	S03 (9S)
720.0	0.93	S04 (9S)
250.0	0.76	S05 (9S)
5,200.0	1.00	S06 (9S)
690.0	1.00	S07 (9S)
105.0	1.00	S08 (14S)
99.0	0.72	S09 (14S)
500.0	1.00	Tower A (10S, 11S)
810.0	1.00	Tower B1 (10S, 12S)
12,164.0	0.95	TOTAL AREA

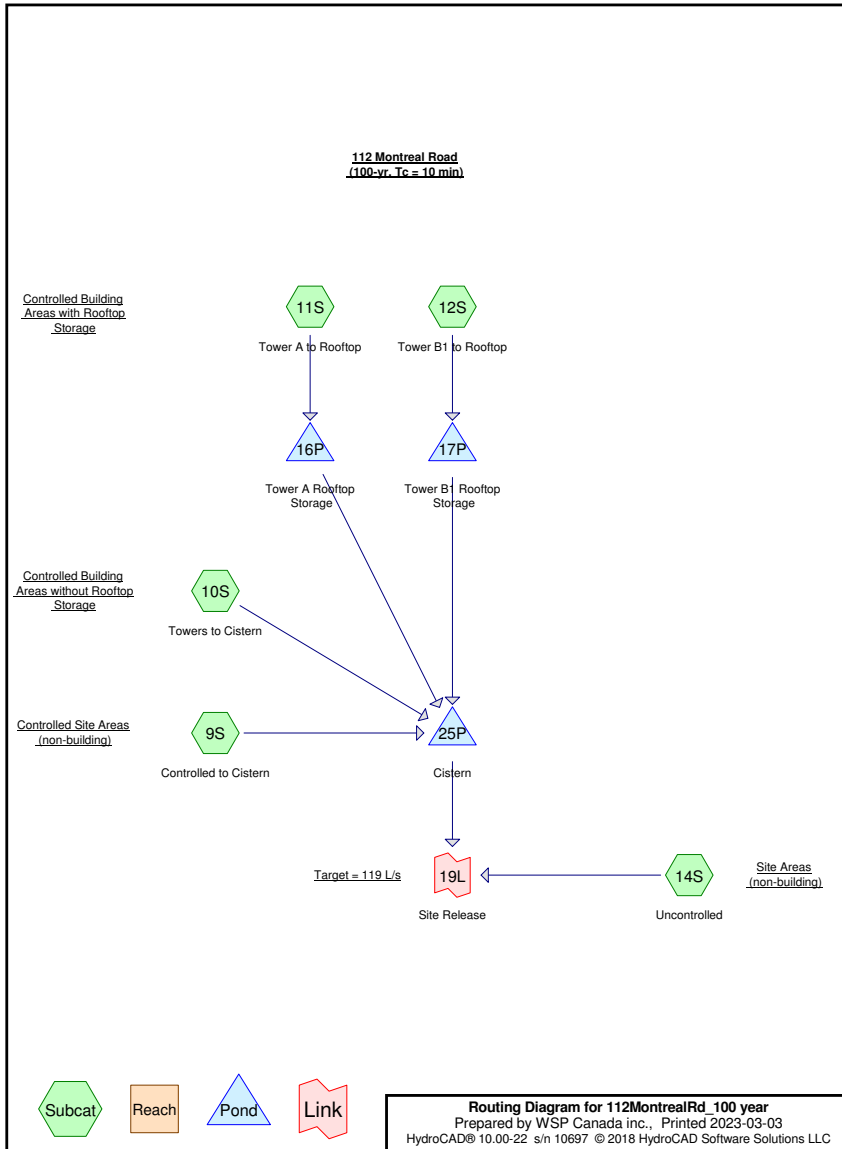

112MontrealRd_100 year

Prepared by WSP Canada inc.

HydroCAD® 10.00-22 s/n 10697 © 2018 HydroCAD Software Solutions LLC

Ottawa 100-Year Duration=72 min, Inten=48.7 mm/hr

Printed 2023-03-03

Page 3

Time span=0.00-4.00 hrs, dt=0.01 hrs, 401 points

Runoff by Rational method, Rise/Fall=1.0/1.0 xTc

Reach routing by Stor-Ind+Trans method - Pond routing by Stor-Ind method

Subcatchment 9S: Controlled to CisternRunoff Area=10,650.0 m² Runoff Depth=56 mm
Tc=10.0 min C=0.95 Runoff=0.1370 m³/s 591.8 m³**Subcatchment 10S: Towers to Cistern**Runoff Area=637.0 m² Runoff Depth=58 mm
Tc=10.0 min C=1.00 Runoff=0.0086 m³/s 37.3 m³**Subcatchment 11S: Tower A to Rooftop**Runoff Area=310.0 m² Runoff Depth=58 mm
Tc=10.0 min C=1.00 Runoff=0.0042 m³/s 18.1 m³**Subcatchment 12S: Tower B1 to Rooftop**Runoff Area=363.0 m² Runoff Depth=58 mm
Tc=10.0 min C=1.00 Runoff=0.0049 m³/s 21.2 m³**Subcatchment 14S: Uncontrolled**Runoff Area=204.0 m² Runoff Depth=50 mm
Tc=10.0 min C=0.86 Runoff=0.0024 m³/s 10.3 m³**Pond 16P: Tower A Rooftop Storage** Peak Elev=100.085 m Storage=11.2 m³ Inflow=0.0042 m³/s 18.1 m³
Outflow=0.0015 m³/s 18.1 m³**Pond 17P: Tower B1 Rooftop Storage** Peak Elev=100.142 m Storage=15.4 m³ Inflow=0.0049 m³/s 21.2 m³
Outflow=0.0012 m³/s 17.7 m³**Pond 25P: Cistern** Peak Elev=55.083 m Storage=218.9 m³ Inflow=0.1484 m³/s 664.9 m³
Primary=0.1115 m³/s 653.0 m³ Secondary=0.0000 m³/s 0.0 m³ Outflow=0.1115 m³/s 653.0 m³**Link 19L: Site Release** Inflow=0.1139 m³/s 663.3 m³
Primary=0.1139 m³/s 663.3 m³**Total Runoff Area = 12,164.0 m² Runoff Volume = 678.6 m³ Average Runoff Depth = 56 mm****112MontrealRd_100 year**

Prepared by WSP Canada inc.

HydroCAD® 10.00-22 s/n 10697 © 2018 HydroCAD Software Solutions LLC

Ottawa 100-Year Duration=72 min, Inten=48.7 mm/hr

Printed 2023-03-03

Page 4

Summary for Subcatchment 9S: Controlled to CisternRunoff = 0.1370 m³/s @ 0.17 hrs, Volume= 591.8 m³, Depth= 56 mmRunoff by Rational method, Rise/Fall=1.0/1.0 xTc, Time Span= 0.00-4.00 hrs, dt= 0.01 hrs
Ottawa 100-Year Duration=72 min, Inten=48.7 mm/hr

Area (m ²)	C	Description
3,790.0	0.89	S03
5,200.0	1.00	S06
720.0	0.93	S04
250.0	0.76	S05
690.0	1.00	S07
10,650.0	0.95	Weighted Average

Tc (min)	Length (meters)	Slope (m/m)	Velocity (m/sec)	Capacity (m ³ /s)	Description
10.0					Direct Entry,

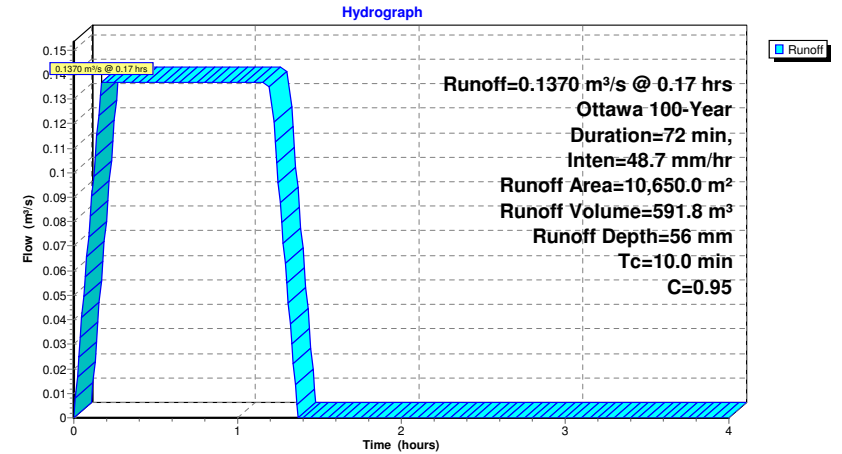
Subcatchment 9S: Controlled to Cistern

112MontrealRd_100 year

Prepared by WSP Canada inc.

HydroCAD® 10.00-22 s/n 10697 © 2018 HydroCAD Software Solutions LLC

Ottawa 100-Year Duration=72 min, Inten=48.7 mm/hr

Printed 2023-03-03

Page 5

Summary for Subcatchment 10S: Towers to Cistern

Runoff = 0.0086 m³/s @ 0.17 hrs, Volume= 37.3 m³, Depth= 58 mm

Runoff by Rational method, Rise/Fall=1.0/1.0 xTc, Time Span= 0.00-4.00 hrs, dt= 0.01 hrs
 Ottawa 100-Year Duration=72 min, Inten=48.7 mm/hr

Area (m²)	C	Description
190.0	1.00	Tower A
447.0	1.00	Tower B1
637.0	1.00	Weighted Average

Tc (min)	Length (meters)	Slope (m/m)	Velocity (m/sec)	Capacity (m³/s)	Description
10.0					Direct Entry,

Subcatchment 10S: Towers to Cistern

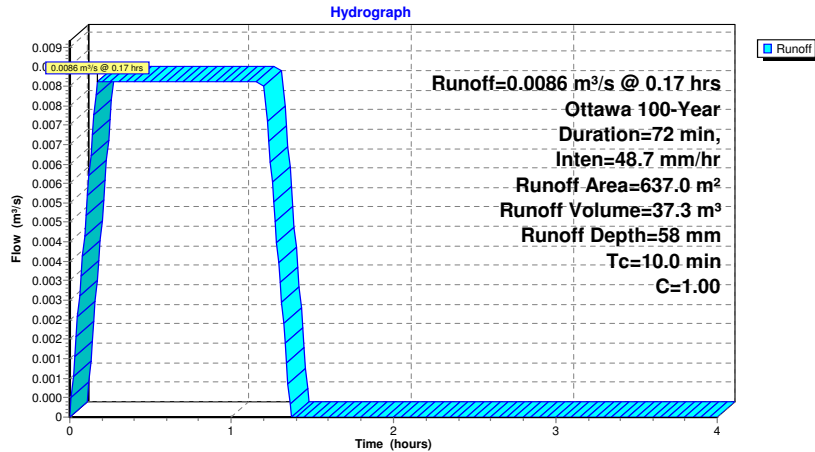

112MontrealRd_100 year

Prepared by WSP Canada inc.

HydroCAD® 10.00-22 s/n 10697 © 2018 HydroCAD Software Solutions LLC

Ottawa 100-Year Duration=72 min, Inten=48.7 mm/hr

Printed 2023-03-03

Page 6

Summary for Subcatchment 11S: Tower A to Rooftop

Runoff = 0.0042 m³/s @ 0.17 hrs, Volume= 18.1 m³, Depth= 58 mm

Runoff by Rational method, Rise/Fall=1.0/1.0 xTc, Time Span= 0.00-4.00 hrs, dt= 0.01 hrs
 Ottawa 100-Year Duration=72 min, Inten=48.7 mm/hr

Area (m²)	C	Description
310.0	1.00	Tower A

Tc (min)	Length (meters)	Slope (m/m)	Velocity (m/sec)	Capacity (m³/s)	Description
10.0					Direct Entry,

Subcatchment 11S: Tower A to Rooftop

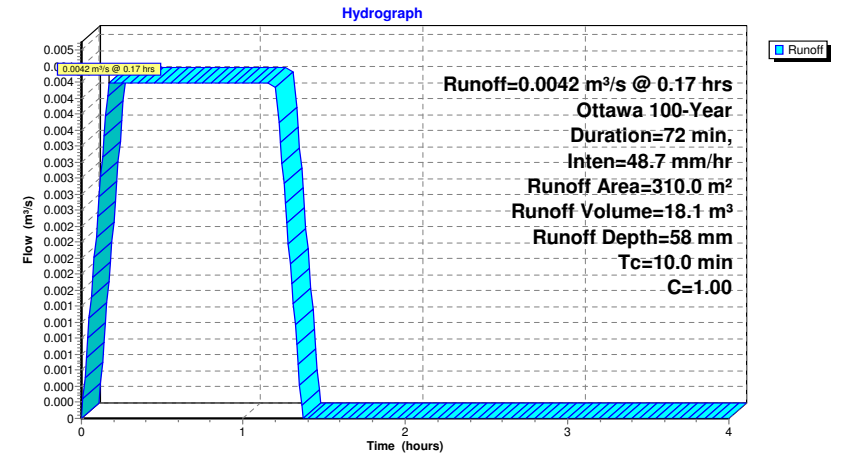

112MontrealRd_100 year

Prepared by WSP Canada inc.

HydroCAD® 10.00-22 s/n 10697 © 2018 HydroCAD Software Solutions LLC

Ottawa 100-Year Duration=72 min, Inten=48.7 mm/hr

Printed 2023-03-03

Page 7

Summary for Subcatchment 12S: Tower B1 to Rooftop

Runoff = 0.0049 m³/s @ 0.17 hrs, Volume= 21.2 m³, Depth= 58 mm

Runoff by Rational method, Rise/Fall=1.0/1.0 xTc, Time Span= 0.00-4.00 hrs, dt= 0.01 hrs
Ottawa 100-Year Duration=72 min, Inten=48.7 mm/hr

Area (m²)	C	Description
363.0	1.00	Tower B1

Tc (min)	Length (meters)	Slope (m/m)	Velocity (m/sec)	Capacity (m³/s)	Description
10.0					Direct Entry,

Subcatchment 12S: Tower B1 to Rooftop

Hydrograph

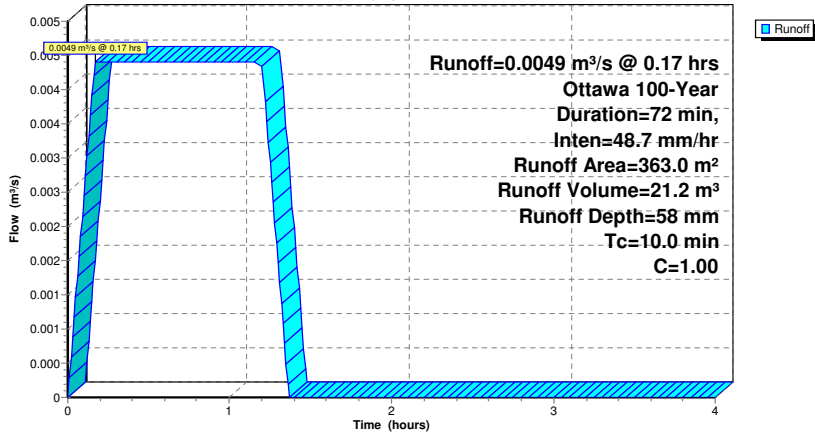

112MontrealRd_100 year

Prepared by WSP Canada inc.

HydroCAD® 10.00-22 s/n 10697 © 2018 HydroCAD Software Solutions LLC

Ottawa 100-Year Duration=72 min, Inten=48.7 mm/hr

Printed 2023-03-03

Page 8

Summary for Subcatchment 14S: Uncontrolled

Runoff = 0.0024 m³/s @ 0.17 hrs, Volume= 10.3 m³, Depth= 50 mm

Runoff by Rational method, Rise/Fall=1.0/1.0 xTc, Time Span= 0.00-4.00 hrs, dt= 0.01 hrs
Ottawa 100-Year Duration=72 min, Inten=48.7 mm/hr

Area (m²)	C	Description
99.0	0.72	S09
105.0	1.00	S08
204.0	0.86	Weighted Average

Tc (min)	Length (meters)	Slope (m/m)	Velocity (m/sec)	Capacity (m³/s)	Description
10.0					Direct Entry,

Subcatchment 14S: Uncontrolled

Hydrograph

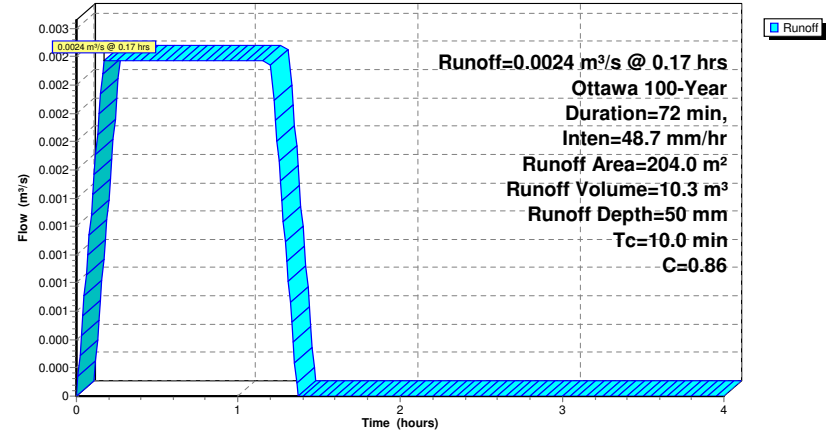

112MontrealRd_100 year

Prepared by WSP Canada inc.

HydroCAD@ 10.00-22 s/n 10697 © 2018 HydroCAD Software Solutions LLC

Ottawa 100-Year Duration=72 min, Inten=48.7 mm/hr

Printed 2023-03-03

Page 9

Summary for Pond 16P: Tower A Rooftop Storage

Inflow Area = 310.0 m², Inflow Depth = 58 mm for 100-Year event
 Inflow = 0.0042 m³/s @ 0.17 hrs, Volume= 18.1 m³
 Outflow = 0.0015 m³/s @ 0.19 hrs, Volume= 18.1 m³, Atten= 63%, Lag= 1.2 min
 Primary = 0.0015 m³/s @ 0.19 hrs, Volume= 18.1 m³

Routing by Stor-Ind method, Time Span= 0.00-4.00 hrs, dt= 0.01 hrs
 Peak Elev= 100.085 m @ 1.31 hrs Surf.Area= 263.3 m² Storage= 11.2 m³

Plug-Flow detention time= 61.8 min calculated for 18.1 m³ (100% of inflow)
 Center-of-Mass det. time= 62.0 min (103.0 - 41.0)

Volume	Invert	Avail.Storage	Storage Description
#1	100.000 m	15.5 m ³	Custom Stage Data (Prismatic) Listed below (Recalc) x 5

Elevation (meters)	Surf.Area (sq-meters)	Inc.Store (cubic-meters)	Cum.Store (cubic-meters)
100.000	0.0	0.0	0.0
100.100	62.0	3.1	3.1

Device	Routing	Invert	Outlet Devices
#1	Primary	100.000 m	WATTS Accutrol_5-Closed X 5.00 Head (meters) 0.000 0.025 0.051 0.076 0.102 0.127 0.152 Disch. (m ³ /s) 0.00000 0.00031 0.00031 0.00031 0.00031 0.00031 0.00031 0.00031

Primary OutFlow Max=0.0015 m³/s @ 0.19 hrs HW=100.026 m (Free Discharge)
 ↳1=WATTS Accutrol_5-Closed (Custom Controls 0.0015 m³/s)

112MontrealRd_100 year

Prepared by WSP Canada inc.

HydroCAD@ 10.00-22 s/n 10697 © 2018 HydroCAD Software Solutions LLC

Ottawa 100-Year Duration=72 min, Inten=48.7 mm/hr

Printed 2023-03-03

Page 10

Pond 16P: Tower A Rooftop Storage

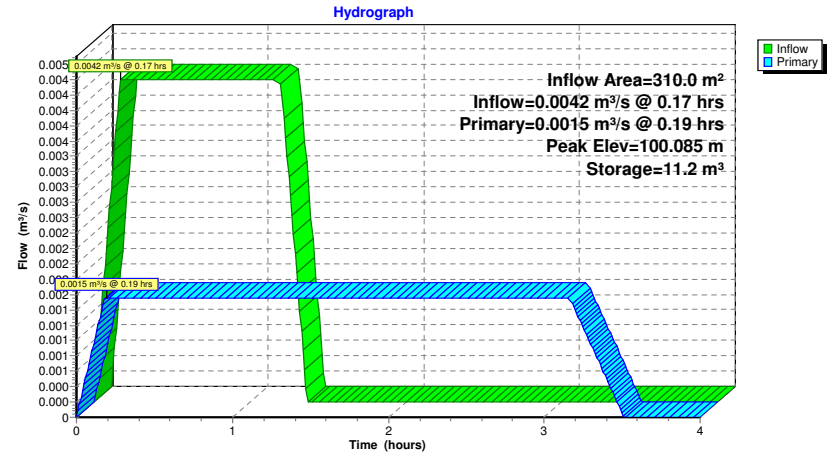

112MontrealRd_100 year

Prepared by WSP Canada inc.

HydroCAD® 10.00-22 s/n 10697 © 2018 HydroCAD Software Solutions LLC

Ottawa 100-Year Duration=72 min, Inten=48.7 mm/hr

Printed 2023-03-03

Page 11

Summary for Pond 17P: Tower B1 Rooftop Storage

Inflow Area = 363.0 m², Inflow Depth = 58 mm for 100-Year event
 Inflow = 0.0049 m³/s @ 0.17 hrs, Volume= 21.2 m³
 Outflow = 0.0012 m³/s @ 0.07 hrs, Volume= 17.7 m³, Atten= 75%, Lag= 0.0 min
 Primary = 0.0012 m³/s @ 0.07 hrs, Volume= 17.7 m³

Routing by Stor-Ind method, Time Span= 0.00-4.00 hrs, dt= 0.01 hrs
 Peak Elev= 100.142 m @ 1.32 hrs Surf.Area= 324.7 m² Storage= 15.4 m³

Plug-Flow detention time= 85.8 min calculated for 17.7 m³ (83% of inflow)
 Center-of-Mass det. time= 80.1 min (121.1 - 41.0)

Volume	Invert	Avail.Storage	Storage Description
#1	100.000 m	18.1 m ³	Custom Stage Data (Pyramidal) Listed below (Recalc) x 4

Elevation (meters)	Surf.Area (sq-meters)	Inc.Store (cubic-meters)	Cum.Store (cubic-meters)	Wet.Area (sq-meters)
100.000	0.0	0.0	0.0	0.0
100.150	90.7	4.5	4.5	90.7

Device	Routing	Invert	Outlet Devices
#1	Primary	100.000 m	WATTS Accutrol_5-Closed X 4.00 Head (meters) 0.000 0.025 0.051 0.076 0.102 0.127 0.152 Disch. (m ³ /s) 0.00000 0.00031 0.00031 0.00031 0.00031 0.00031 0.00031 0.00031

Primary OutFlow Max=0.0012 m³/s @ 0.07 hrs HW=100.025 m (Free Discharge)
 ↳1=WATTS Accutrol_5-Closed (Custom Controls 0.0012 m³/s)

112MontrealRd_100 year

Prepared by WSP Canada inc.

HydroCAD® 10.00-22 s/n 10697 © 2018 HydroCAD Software Solutions LLC

Ottawa 100-Year Duration=72 min, Inten=48.7 mm/hr

Printed 2023-03-03

Page 12

Pond 17P: Tower B1 Rooftop Storage

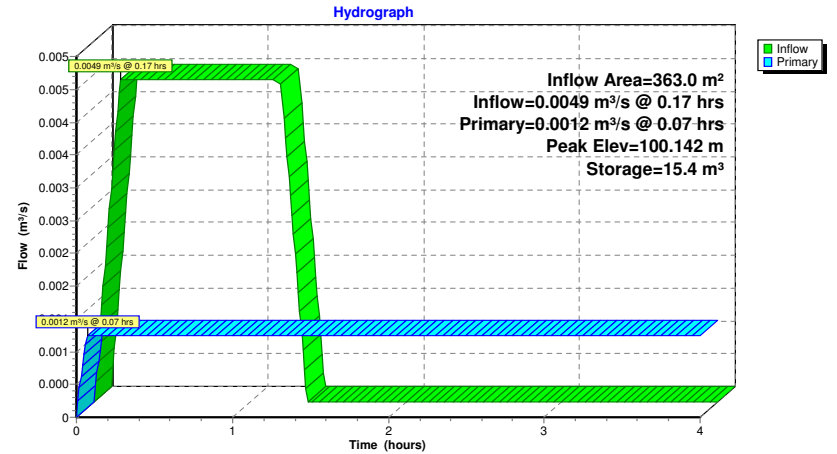

Summary for Pond 25P: Cistern

Inflow Area = 11,960.0 m², Inflow Depth > 56 mm for 100-Year event
 Inflow = 0.1484 m³/s @ 0.19 hrs, Volume= 664.9 m³
 Outflow = 0.1115 m³/s @ 1.43 hrs, Volume= 653.0 m³, Atten= 25%, Lag= 74.3 min
 Primary = 0.1115 m³/s @ 1.43 hrs, Volume= 653.0 m³
 Secondary = 0.0000 m³/s @ 0.00 hrs, Volume= 0.0 m³

Routing by Stor-Ind method, Time Span= 0.00-4.00 hrs, dt= 0.01 hrs
 Peak Elev= 55.083 m @ 1.24 hrs Surf.Area= 0.0 m² Storage= 218.9 m³

Plug-Flow detention time= 25.0 min calculated for 651.4 m³ (98% of inflow)
 Center-of-Mass det. time= 22.6 min (67.4 - 44.8)

Volume	Invert	Avail.Storage	Storage Description
#1	54.250 m	314.5 m ³	Custom Stage Data Listed below

Elevation (meters)	Cum.Store (cubic-meters)
54.250	0.0
54.280	7.4
54.350	29.3
54.460	58.2
54.560	86.5
54.660	114.3
54.760	141.3
54.860	167.5
54.960	192.5
55.070	216.1
55.170	238.0
55.270	256.9
55.370	272.1
55.470	286.2
55.570	300.4
55.680	314.5

Device	Routing	Invert	Outlet Devices
#1	Primary	54.250 m	SHE-0408-1120-1430-1120_HydroBrake Head (meters) 0.000 0.014 0.029 0.043 0.058 0.072 0.087 0.101 0.116 0.130 0.144 0.159 0.173 0.188 0.202 0.217 0.231 0.246 0.260 0.274 0.289 0.303 0.318 0.332 0.347 0.361 0.376 0.390 0.404 0.419 0.433 0.448 0.462 0.477 0.491 0.506 0.520 0.534 0.549 0.563 0.578 0.592 0.607 0.621 0.636 0.650 0.664 0.679 0.693 0.708 0.722 0.737 0.751 0.766 0.780 0.794 0.809 0.823 0.838 0.852 0.867 0.881 0.896 0.910 0.924 0.939 0.953 0.968 0.982 0.997 1.011 1.026 1.040 1.054 1.069 1.083 1.098 1.112 1.127 1.141 1.156 1.170 1.184 1.199 1.213 1.228 1.242 1.257 1.271 1.286 1.300 1.314 1.329 1.343 1.358 1.372 1.387 1.401 1.416 1.430 1.459 1.487 1.516 1.544 1.573 1.602 1.630 1.659 1.687 1.716 Disch. (m ³ /s) 0.00000 0.00025 0.00099 0.00220 0.00386 0.00596

0.00847	0.01137	0.01465	0.01827	0.02221	0.02646	0.03097
0.03574	0.04072	0.04588	0.05120	0.05663	0.06214	0.06769
0.07323	0.07874	0.08430	0.08953	0.09447	0.09917	0.10365
0.10677	0.10741	0.10800	0.10853	0.10901	0.10944	0.10982
0.11016	0.11045	0.11070	0.11092	0.11109	0.11123	0.11134
0.11142	0.11146	0.11148	0.11147	0.11144	0.11138	0.11131
0.11121	0.11109	0.11095	0.11080	0.11062	0.11043	0.11022
0.11000	0.10976	0.10950	0.10923	0.10893	0.10862	0.10829
0.10793	0.10755	0.10715	0.10672	0.10626	0.10577	0.10525
0.10469	0.10408	0.10344	0.10275	0.10200	0.10121	0.10035
0.09943	0.09904	0.09966	0.10028	0.10089	0.10150	0.10211
0.10271	0.10331	0.10390	0.10450	0.10508	0.10567	0.10625
0.10683	0.10740	0.10797	0.10854	0.10911	0.10967	0.11023
0.11078	0.11134	0.11189	0.11292	0.11396	0.11500	0.11604
0.11707	0.11811	0.11915	0.12018	0.12122	0.12226	

#2 Secondary 56.480 m *****Overflow Check**
 Head (meters) 0.000 0.010
 Disch. (m³/s) 0.00000 10.00000

Primary OutFlow Max=0.1115 m³/s @ 1.43 hrs HW=54.874 m (Free Discharge)
 ↳1=SHE-0408-1120-1430-1120_HydroBrake (Custom Controls 0.1115 m³/s)

Secondary OutFlow Max=0.0000 m³/s @ 0.00 hrs HW=54.250 m (Free Discharge)
 ↳2=***Overflow Check (Controls 0.0000 m³/s)

Pond 25P: Cistern

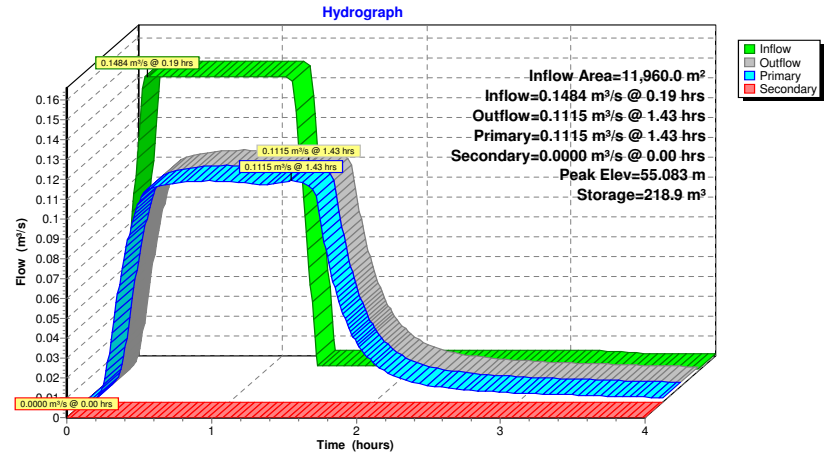

Summary for Link 19L: Site Release

Inflow Area = 12,164.0 m², Inflow Depth > 55 mm for 100-Year event
Inflow = 0.1139 m³/s @ 0.86 hrs, Volume= 663.3 m³
Primary = 0.1139 m³/s @ 0.86 hrs, Volume= 663.3 m³, Atten= 0%, Lag= 0.0 min

Primary outflow = Inflow, Time Span= 0.00-4.00 hrs, dt= 0.01 hrs

Link 19L: Site Release

Hydrograph

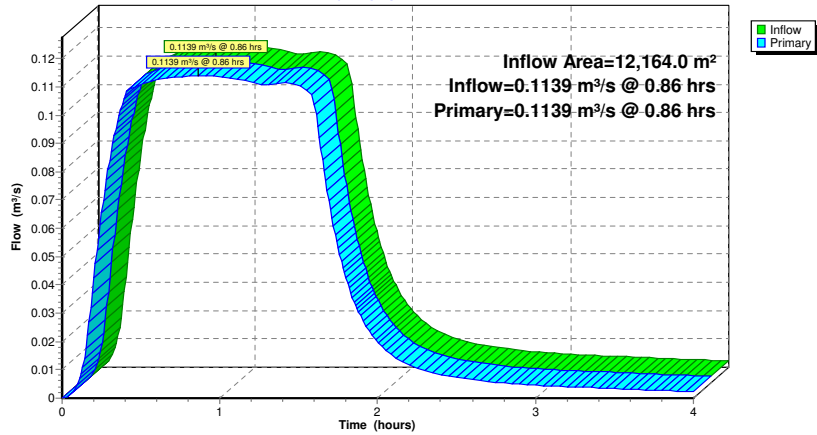

APPENDIX

H

FLOOD PLAIN
MAPPING AND
ELEVATIONS

Rideau River at Cumming Island



Legend

- OHN Watercourse
- RVCA Sub-Watersheds
- RVCA Catchments
- Floodplain Cross-sections
- Regulation Limit
- 100yr Floodline
- Reg Limit Dominant Hazard**
- Floodplain
- Geo-technical Hazard Limit
- Meander Belt
- Stable Slope
- Top of Slope
- Unstable Slope
- Wetland
- Township Municipal
- Geographic Township
- Conservation Authorities (East)
- Roads**
- Freeway
- Expressway / Highway
- Arterial
- Local
- Ramp
- Rapid Transit
- Service
- Waterbody
- Wetlands**
- Evaluated-Provincial
- Evaluated-Other
- Not evaluated per OWES

DATE 2014



1: 15,084.78

Map Projection: WGS_1984_Web_Mercator_Auxiliary_Sphere

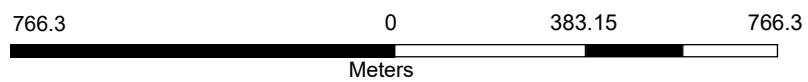

Map produced by RVCA, under License with the Ontario Ministry of Natural Resources © Queen's Printer for Ontario, 2015. This map is the property of the RVCA, and the RVCA holds a copyright on them. These maps may be copied or reproduced, provided that the RVCA is properly acknowledged as the original source of the information and provided that no fee is charged (other than to cover handling charges). The RVCA cannot guarantee the accuracy of the mapping for all possible uses. End-users of the information contained herein must therefore determine if the information is of suitable accuracy for their purposes

Notes

Parcel data is owned by Teranet Enterprises Inc and its suppliers. All rights reserved. May not be reproduced without permission.

Data Received from RVCA September 2015

FPM_UNIQUE	PROFILE	Q_TOTAL_C	WS_ELEV_M	EG_ELEV_M
Rideau - Reach 1 - 2474	50 Year	626	56.44	56.52
Rideau - Reach 1 - 2474	5 Year	513	56.1	56.17
Rideau - Reach 1 - 2474	25 Year	598	56.36	56.44
Rideau - Reach 1 - 2474	100 Year	654	56.52	56.6
Rideau - Reach 1 - 2474	10 Year	552	56.22	56.29
Rideau - Reach 1 - 2490	50 Year	626	56.46	56.54
Rideau - Reach 1 - 2490	5 Year	513	56.12	56.18
Rideau - Reach 1 - 2490	25 Year	598	56.38	56.46
Rideau - Reach 1 - 2490	100 Year	654	56.54	56.63
Rideau - Reach 1 - 2490	10 Year	552	56.24	56.31
Rideau - Reach 1 - 2512	50 Year	626	56.47	56.55
Rideau - Reach 1 - 2512	5 Year	513	56.13	56.19
Rideau - Reach 1 - 2512	25 Year	598	56.39	56.47
Rideau - Reach 1 - 2512	100 Year	654	56.56	56.64
Rideau - Reach 1 - 2512	10 Year	552	56.25	56.32