

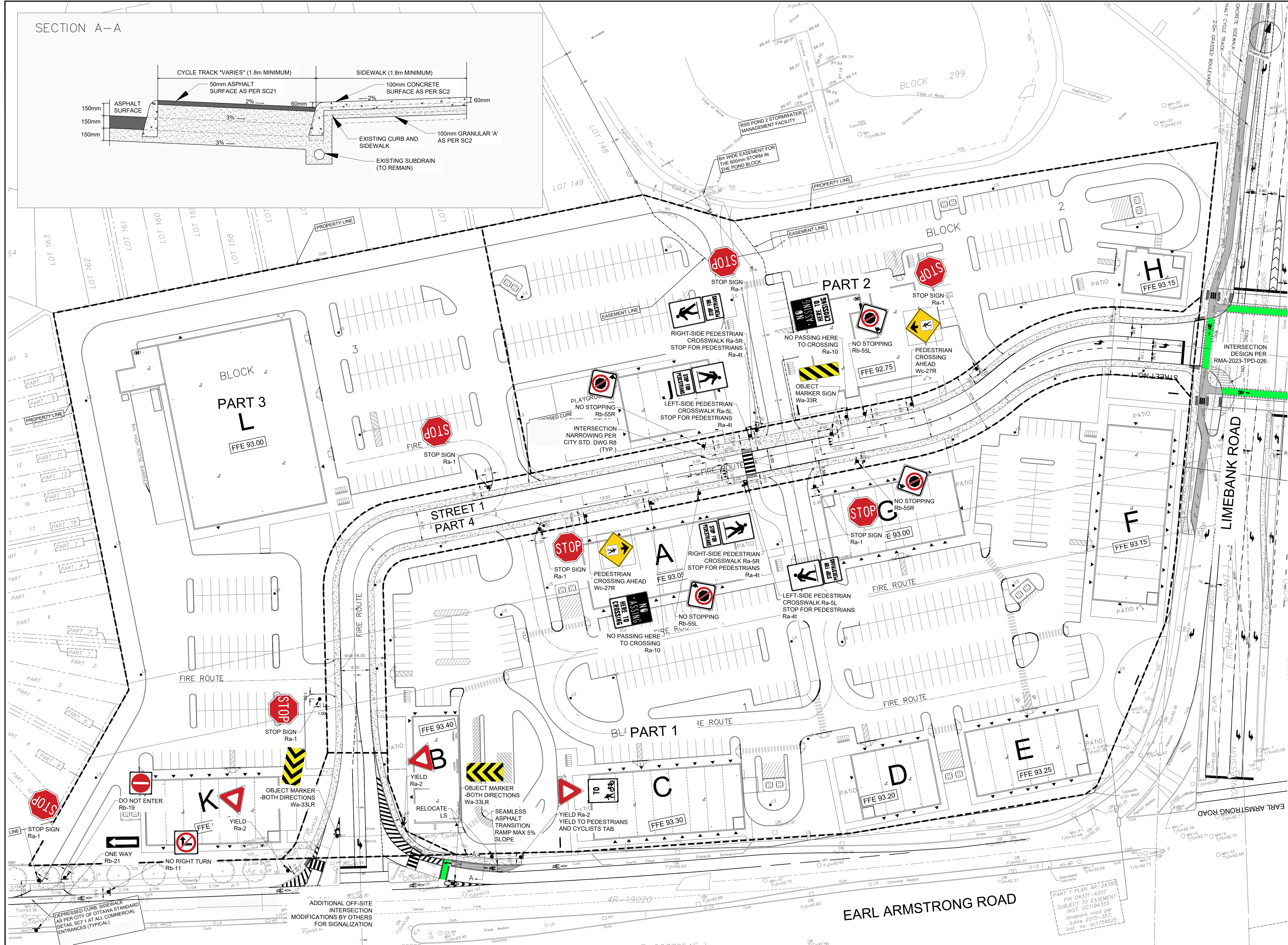

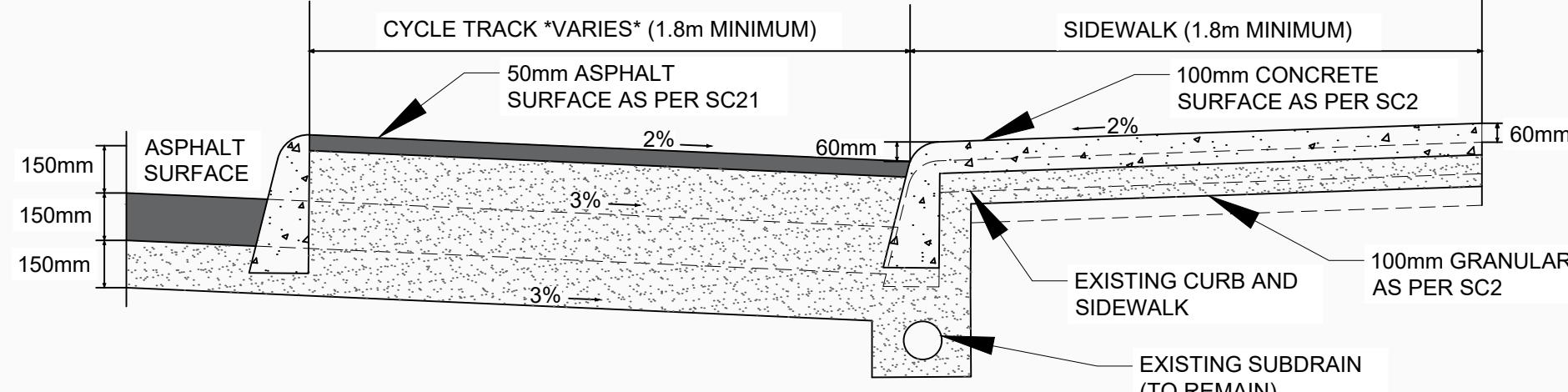

SECTION A-A



**CLIENT**

**COPYRIGHT**  
 This drawing has been prepared solely for the intended use, and any reproduction or distribution for any purpose other than authorized by IBI Group is forbidden. IBI Group shall be held responsible for all dimensions and conditions on the job, and IBI Group shall be informed of any variations from the dimensions and conditions shown on the drawing. Shop drawings shall be submitted to IBI Group for general confirmation before proceeding with fabrication.  
 IBI Group Professional Services (Canada) Inc.  
 is a member of the IBI Group of companies.

ISSUES	DESCRIPTION	DATE
No. 1	SUBMISSION No.1 FOR CITY REVIEW	D.H. 2022:12:14
No. 2	SUBMISSION No.2 FOR CITY REVIEW	D.H. 2023:04:26
No. 3	SUBMISSION No.3 FOR CITY REVIEW	D.H. 2023:06:07
No. 4	SUBMISSION No.4 FOR CITY REVIEW	D.H. 2023:06:29

**KEY PLAN**

**CONSULTANTS**

- DEPRESSED CURB
- TWSI (PER SC7.3)
- CATCH BASIN
- REAR YARD CATCH BASIN IN ROAD
- FIRE TRANSFORMER
- FIRE HYDRANT
- MOUNTABLE CURB
- BARRIER CURB
- Phasing Boundary

**SEAL**

**IBI GROUP**  
 Suite 500 - 333 Preston Street  
 Ottawa ON K1S 5N4 Canada  
 Tel: 613 225 1311 / 613 241 3300 Fax: 613 225 9868  
 ibigroup.com

**PROJECT**  
 1515 EARL ARMSTRONG PLAZA

**PROJECT NO:** 137404

**DRAWN BY:** IL

**CHECKED BY:** DH

**PROJECT MGR:** SEL

**APPROVED BY:** DH

**SHEET TITLE**  
 GEOMETRIC ROADWAY DESIGN DRAWING

**SHEET NUMBER** 020 **ISSUE** 1

SCALE CHECK: 1:5000

FILE LOCATION: \\137404\_Earl\_Armstrong\_03\_Design\03\_TrafficContent\020 GR0D - 2023-03-15.dwg

PHOTO: Tuesday, July 04, 2023 15:02:00 BY Isabel Lowman