



**Servicing and Stormwater
Management Report
CHEO Parking Garage
401 Smyth Road, Ottawa, ON**

Client:

B+H Architects
481 University Avenue, Suite 300
Toronto, ON M5G 2H4

EXP Project Number: MRK-21023468-A0

Prepared By:

EXP Services Inc.
100-2650 Queensview Drive
Ottawa, ON K2B 8H6
T: +1.613.688.1899
F: +1.613.225.7337

Date Submitted:

December 16, 2022

Servicing and Stormwater Management Report CHEO Parking Garage 401 Smyth Road, Ottawa, Ontario

Type of Document:
Site Plan Control Application

Client:
B+H Architects
481 University Avenue, Suite 300
Toronto, ON M5G 2H4

EXP Project Number:
MRK-21023468-A0

Prepared By:
EXP Services Inc.
100-2650 Queensview Drive
Ottawa, ON K2B 8H6
T: 613 688-1899
F: 613 225-7337
www.exp.com



Karlinda Hinds, P.Eng.
Project Manager
Infrastructure Services



Alam Ansari, M.Sc., P.Eng.
Director of Operations, Eastern Ontario
Infrastructure Services

Date Submitted:
December 16, 2022

Legal Notification

This report was prepared by EXP Services Inc. for the account of **B+H Architects**.

Any use which a third party makes of this report, or any reliance on or decisions to be made based on it, are the responsibility of such third parties. EXP Services Inc. accepts no responsibility for damages, if any, suffered by any third party as a result of decisions made or actions based on this project.

Table of Contents

| | | |
|----------|--|----------|
| 1 | Introduction | 1 |
| 2 | References..... | 1 |
| 3 | Sanitary Sewer Design..... | 2 |
| | 3.1 Existing Conditions | 2 |
| | 3.2 Peak Design Flow..... | 2 |
| | 3.3 Capacity of Existing Sewers | 2 |
| 4 | Watermain Design..... | 3 |
| | 4.1 Existing Conditions | 3 |
| | 4.2 Required Fire Flow | 3 |
| | 4.3 Water Demands..... | 3 |
| | 4.4 Watermain Analysis | 3 |
| | 4.5 Review of Hydrant Spacing..... | 4 |
| 5 | Stormwater Management..... | 5 |
| | 5.1 Existing Conditions | 5 |
| | 5.2 Storm Design Criteria | 5 |
| | 5.3 Allowable Release Rate..... | 6 |
| | 5.4 Post-Development Conditions | 6 |
| | 5.4.1 Quantity Control..... | 6 |
| | 5.4.2 Quality Control | 8 |
| 6 | Erosion and Sediment Control..... | 8 |
| 7 | Conclusions..... | 9 |

List of Appendices

Appendix A – Background Information

Appendix B – Watermain Design

Appendix C – Stormwater Design

1 Introduction

B+H Architects has retained EXP Services Inc. (EXP) to undertake a site servicing and stormwater management study in support of a Site Plan Control application for a new parking garage owned by the Children's Hospital of Eastern Ontario (CHEO). The parking garage is proposed to be built at the Ottawa Health Sciences Centre (OHSC) located at 401 Smyth Road in Ottawa, Ontario.

The area to be developed is approximately 1.12 hectares and is located southeast of the CHEO building as shown on Figure 1 in Appendix A. The site is currently used as a gravel parking lot.

The description of the subject property is noted below:

- Part of Lot 15, Concession Junction Gore
- PIN 04258-0401 (LT)
- PIN 04258-0421 (LT)

This report will discuss the existing conditions of the site and the proposed site servicing and stormwater management for the development. It will also address Sediment and Control Measures that will need to be implemented for this project. This report provides a design brief for submission, along with the engineering drawings, for City approval.

2 References

Various documents were referred to in preparing the current report including:

- Sewer Design Guidelines, Second Edition, Document SDG002, October 2012, City of Ottawa (Guidelines)
- City of Ottawa Water Distribution Design Guidelines, July 2010 (WDG001)
- Stormwater Management Planning and Design Manual, Ontario Ministry of the Environment, March 2003 (MOE SMPDM)
- Fire Underwriters Survey, Water Supply for Public Fire Protection (FUS), 2020
- Ottawa Health Sciences Centre Site Services Assessment by J.L. Richards & Associates Limited, dated January 2011
- Ottawa Health Sciences Centre Storm and Sanitary Sewer Capacity Assessment by Morrison Hershfield, dated May 1, 2017
- Ottawa Health Sciences Centre Stormwater Master Plan by Morrison Hershfield, dated July 2019
- 1Door4Care: CHEO Integrated Treatment Centre – Geotechnical Investigation Report (Parking Garage) by GHD, dated October 25, 2022

3 Sanitary Sewer Design

3.1 Existing Conditions

The existing private sanitary sewer system within the OHSC campus consists of sewers ranging in size between 200mm and 381mm with smaller diameter services for various buildings. All of the sanitary sewers on the OHSC campus converge at the northwest corner of the site where the system outlets into a City of Ottawa municipal sewer which ultimately outlets to the Rideau River Collector Sewer.

3.2 Peak Design Flow

The anticipated peak sanitary flows from the proposed parking garage have been calculated as per the City of Ottawa Guidelines (SDG02, 2012). The anticipated peak sanitary flows are as follows:

| | |
|--------------------------|-----------------------------|
| Commercial Design Flow: | 28,000 L/gross ha/day |
| Development Area: | 1.12 ha |
| Peak Factor: | 1.5 |
| Extraneous Flow: | 0.33 L/s/effective gross ha |
| Peak Design Flow: | 0.91 L/s |

The parking garage is proposed to be serviced by new sanitary sewers that will be connected to an existing 375 mm diameter sewer located north-west of the new Parking Garage. The sanitary sewers will be 200 mm in diameter and will have a minimum slope of 0.5%. At this slope, the 200mm diameter sanitary sewers will have a capacity of 23.2 L/s and a full flow velocity of 0.86 m/s, which will be sufficient to service the proposed parking garage.

3.3 Capacity of Existing Sewers

In 2011, J.L. Richards & Associates completed a site services assessment of the existing sanitary, storm, and water supply systems on the OHSC campus. The capacity of the sanitary sewers was evaluated under existing conditions as well as taking into consideration future planned development which included the proposed parking garage. Flow monitoring was completed on the campus as part of this assessment to verify theoretical flows and peaking factors. This study concluded that, under future conditions, the private sanitary sewer network still has approximately 80% residual capacity. Therefore, there is more than sufficient capacity in the sanitary system for the proposed development.

The 2011 J.L. Richards report also discussed the impact of future development at the OHSC campus on the downstream City of Ottawa municipal sewers. The OHSC sanitary flows are conveyed to the Rideau River Collector Sewer via a 375mm diameter sewer with a capacity of approximately 215 L/s which provides more than enough capacity for the OHSC campus. Please refer to the 2011 J.L. Richards report for more information.

4 Watermain Design

4.1 Existing Conditions

The existing private water supply system at the OHSC campus consists of two major watermains: (i) A 203mm watermain feed from the 305mm municipal watermain on Smyth Road and (ii) A 305mm watermain loop feed from the 305mm municipal watermain on Smyth Road that connects at two locations. There are 3 private hydrants and 1 municipal hydrant (color: blue, Class AA) within 150m of the new Parking Garage location.

4.2 Required Fire Flow

The fire flow demand calculations were prepared based on the Fire Underwriters Survey (FUS, 2020) criteria and Technical Bulletin 2018-02. The proposed parking garage's type of construction is classified as non-combustible. The structure will have a fully supervised sprinkler system and combustible contents. The required fire flow was determined to be 217 L/s. Refer to Appendix B for detailed fire flow demand calculations.

4.3 Water Demands

The domestic water demands for the proposed building were calculated as per the City of Ottawa Water Distribution Guidelines. Commercial average consumption rate and peak factors were used for the demands calculations. Refer to Appendix B for detailed water demand calculations. The proposed parking garage's domestic demands were determined as follows:

Average Daily Demand:
=28,000 L/ha/day
=(28,000L)(0.49ha)(1/86,400 s/day)
=0.16 L/s

Maximum Daily Demand
=1.5 x avg day
=1.5 x 0.16 L/s
=0.24 L/s

Maximum Hourly Daily Demand
=1.8 x max. day
=1.8 x 0.24 L/s
=0.43 L/s

4.4 Watermain Analysis

The water pressure anticipated at the proposed parking garage FFE was estimated using the boundary conditions provided by the City of Ottawa. A copy of the correspondence received from the City is provided in Appendix B of this report.

The following hydraulic grade line (HGL) boundary conditions were provided:

- Minimum HGL = 123.7 m

- Maximum HGL = 131.5 m
- Max Day + Fire Flow (217 L/sec) = 116.1 m.

The above noted boundary conditions provided by the City were provided at the existing 305mm private watermain to 305mm municipal watermain connection along Smyth Road. The pressure drop between the watermain on Smyth Road and at the proposed water service connection to the 305mm private watermain within the campus was estimated to be minimal, calculated based on the Hazen Williams Formula using the minimum HGL of 123.7 m. The ground elevation at Smyth Road and at the proposed service connection were taken as 82.5m and 81.5m, respectively based on the existing conditions. With this 1m elevation difference and 123m of watermain length, the pressure drop within the 305mm private watermain was found to be in the range of -1.2 psi to -1.4 psi for average day, max day and peak hour demands. The negative pressure drop indicates increase in the pressure due to 1m elevation drop over 123m watermain length. With the minimum HGL, the available pressure at the proposed service connection to 305mm private watermain was found to be ± 60 psi during the domestic demands. The pressure analysis was also done using the maximum HGL provided by the City. With the maximum HGL, the available pressure at the proposed service connection to 305mm private watermain was found to be ± 71 psi. The estimated pressure drop between the watermain connection (60 psi) to the building FFE (83.0m) is ± 2.1 psi considering a 200mm water service connections. Therefore, the anticipated pressure at the building FFE during the domestic demands will be ± 58 psi with minimum HGL and ± 69 psi with maximum HGL. The anticipated pressure at the building FFE is well within the City of Ottawa suggested range of 40 psi to 80 psi. The mechanical engineer will have to evaluate the available pressure at building FFE and proposed booster pumps to service the upper floors, if found necessary.

The building will be fully sprinklered. With an estimated sprinkler demand of 500 USGPM (32 L/sec) for a building of this size, the anticipated pressure at the building FFE would be below 60 psi with a 200mm water service. The sprinkler designer will have to evaluate the system pressure based on an accurate sprinkler demand and suggest any booster pumps for the sprinkler system, if found necessary.

A pressure analysis was also done to check the available pressure in the private 305mm watermain during max day + fire flow demand of 217 L/sec. Based on the HGL of 116.1 m, the residual pressure in the private watermain at the proposed development was found to be ± 42 psi (with 5.0 psi pressure drop). This residual pressure is well above the minimum required pressure of 20 psi by the City.

A detailed pressure analysis calculation sheet is provided in Appendix B of this report.

Based on this information, the existing 305mm private watermain has sufficient capacity to service the proposed development for the domestic and fire flow demands. A 200mm water service will be sufficient to service the proposed development for domestic and sprinkler demands.

4.5 Review of Hydrant Spacing

A review of the hydrant spacing was completed to ensure compliance with Appendix I of Technical Bulletin ISTB-2018-02. As per Section 3 of Appendix I all hydrants within 150 meters were reviewed to assess the total possible contribution of flow from these hydrants. For each hydrant, the distance to the proposed building was estimated to calculate the fire flow contribution. Based on the boundary conditions received from the City and pressure analysis provided in Section 4.4, there are no capacity issues found in the existing watermain near the proposed development.

Table B4 in Appendix B summarizes all fire hydrants within a 150m distance from the proposed building. For each hydrant the distance measured along a fire route or roadway and its contribution to the required fire flow are provided in this table. Figure 2 in Appendix A illustrates the hydrant locations in proximity to the site.

All hydrants under consideration are rated AA (Painted light blue) as per the City of Ottawa – Water Distribution Systems (2010) guidelines. Therefore, the available flow from each of these hydrants was considered as 5700 L/min if within 75 m distance from the proposed development or 3800 L/min if within 75 m to 150 m distance from the proposed development. Based on this, there were 5 existing hydrants found to be accessible, in the vicinity of the proposed development. 4 out of the 5 hydrants are private.

Based on above noted information, a total of 24,700 L/min (412 L/sec) flow would be available from the 5 existing hydrants for firefighting purposes. Therefore, no new hydrants have been proposed for the proposed development.

5 Stormwater Management

5.1 Existing Conditions

The existing private storm sewer system within the OHSC campus consists of several separate sewer networks. All three sewer networks are connected to a 1350mm diameter main sewer line located at the north-west corner of the campus property. This 1350mm diameter main sewer line is connected to Ottawa municipal sewers installed as part of the Alta Vista Hospital Link (AVHL) project, and ultimately outlets to the Rideau River. The AVHL project also included the installation of an oil grit separator (OGS) that provides water quality treatment of stormwater discharge from the OHSC campus.

Previous servicing studies completed on the OHSC campus have identified that the existing storm sewer network does have capacity issues. The post-development release rate for this development will be in accordance with recommendations outlined in the Stormwater Master Plan Study prepared by Morrison Hershfield dated July 2019, to ensure this development does not adversely affect the downstream system.

5.2 Storm Design Criteria

The storm sewer system was designed in conformance with the City of Ottawa Sewer Design Guidelines (SDG02, 2012), and the Stormwater Master Plan Study prepared by Morrison Hershfield dated July 2019. The stormwater servicing design criteria for the proposed development is as follows:

- The proposed on-site storm sewer network / minor system, is designed using Rational Method and Manning's Equation to convey runoff under free flow conditions for the 5-year return period. Please refer to Appendix C for the storm sewer design sheet.
- Maximum allowable ponding depth is 350 mm.
- Average runoff coefficients were calculated for each inlet drainage area using a runoff coefficient of 0.20 for pervious surfaces and 0.90 for impervious surfaces.
- Estimated storage volumes are based on the Modified Rational Method.
- The allowable post-development release rate, up to the 100-year storm event, shall not exceed the pre-development peak flow during 2-year storm event. The allowable peak flow shall be determined by estimating the pre-development average runoff coefficient or 0.5, whichever is less.
- Flows from storm events greater than the 100-year return period will be directed overland towards existing roadways.

Please provide discussion towards the use of LID's for this development as per the RVCA comments.

PDC Response: Ok. This is to be addressed in ProjectCo's stormwater management report. LID/infiltration measures for stormwater management may not be appropriate for this site due to the presence of shallow rock/shale and high water table.

5.3 Allowable Release Rate

The allowable release rate for the site was established using the criteria outlined in Section 5.2 and a time of concentration of 10 minutes.

The following pre-development parameters were used to determine the allowable release rates from the proposed site using the Rational Formula:

$$Q_{ALL} = 2.78 * C_{AVG} * I_T * A$$

where:

Q_{ALL} = Allowable release rate (L/s)

C_{AVG} = Average runoff coefficient

I_T = Average rainfall intensity (mm/h) for return period T and time of concentration, T_c (minutes)

A = Drainage Area (hectares)

Rainfall intensities for the 2-year storm were taken from IDF data for Ottawa. Using a time of concentration (T_c) of 10 min, a runoff coefficient of 0.50, and a total development area of 1.12 ha, the allowable release rate for the site is determined for the 2-year storm is as follows:

$$I_2 = 732.951 / (T_c + 6.199)^{0.810} = 76.81 \text{ mm/h}$$

$$Q_{ALL} = 119.83 \text{ L/s}$$

The allowable post-development release rate for the site will therefore be **119.83 L/s**. Please refer to Appendix C for detailed calculations.

5.4 Post-Development Conditions

5.4.1 Quantity Control

Runoff coefficients used for the post-development conditions were based on actual areas measured in AutoCAD. Runoff coefficients for impervious surfaces (roofs, asphalt, and concrete) were taken as 0.90, whereas pervious surfaces (grass/landscaping) were taken as 0.20, with gravel taken as 0.70.

Post development runoff will be detained on-site for storms up to and including the 100-year storm. The storage volumes required to attenuate the 100-year post-development flow were calculated using the Modified Rational Method. The required SWM storage volumes will be achieved using a combination of surface storage and rooftop storage on the parking garage structure.

Inlet control devices (ICD) will be installed in certain catch basins as identified on the engineering drawings to restrict the flow. *Hydrovex Vertical Vortex* ICDs were selected for each catchbasin and sized based on design head and specified flow rate as per Hydrovex curves included in Appendix C. The ICDs identified on the engineering drawings are to be considered permanent and will not be removed after development.

The following catchment areas are outlined on Drawing C400:

- Catchment areas S01-A & S01-B consist mainly of large grassed area and concrete sidewalk west of the proposed parking garage structure. Runoff in these drainage areas will be captured via catchbasins CB101 & CB102. ICD's are proposed at the catchbasins to restrict flows.
- Catchment area S02 consists of the proposed parking garage building's footprint. Flows will be captured via proposed roof drains with controls.
- Catchment areas S03-A & S03-B consist mainly of the paved drive aisle spanning north and northwest of the proposed building. Flows will be captured via proposed catchbasins CB103 and CB104 and will be restricted via proposed ICDs.
- Catchment area S04 consists of paved and landscaped areas surrounding the proposed building. Flows in this catchment are uncontrolled and sheet drains towards the Ring Road.

Table 5.1 below summarizes post-development storage and release rates.

Table 5.1 Summary of Post-Development Flows

| Area No. | Area (ha) | Max Release Rate (L/s) | Storage Required (m ³) | Available Storage (m ³) |
|--------------------|--------------|------------------------|------------------------------------|-------------------------------------|
| | | 100-yr | 100-yr (MRM) | |
| S01-A | 0.156 | 4.00 | 23.50 | 44.00 |
| S01-B | 0.139 | 4.00 | 21.30 | 37.10 |
| S02-BLDG | 0.484 | 35.64 | 158.20 | 180.00 |
| S03-A | 0.053 | 8.00 | 11.60 | 14.20 |
| S03-B | 0.055 | 2.00 | 23.50 | 32.00 |
| S04 - Uncontrolled | 0.237 | 66.19 | | |
| Totals | 1.123 | 119.83 | 238.10 | 307.30 |

As per Table 5.2, the storage requirements for the catchment areas were determined as follows;

- S01-A will require **21.3 m³** of surface storage to restrict flows to a maximum flow rate of **4.0 L/s** via the utilization of a Hydrovex 50VHV-1 ICD located in CB102.
- S01-B will require **23.5 m³** of surface storage to restrict flows to a maximum flow rate of **4.0 L/s** via the utilization of a Hydrovex 50VHV-1 ICD located in CB101.
- S02 will require **158.2 m³** of rooftop storage to restrict flows to a maximum flow rate of **35.64 L/s** via the utilization of a roof controls. To meet the allotted release rate, it was assumed that the proposed parking garage structure will capture runoff via **twelve (12)** roof drains, each of which is restricting the discharge rate to **2.97 L/s**. The roof drain flow control device is to be selected to provide **2.97 L/s** at a maximum ponding depth of **0.15 m**.
- S03-A will require **11.6 m³** of surface storage to restrict flows to a maximum flow rate of **8.0 L/s** via the utilization of a Hydrovex 75VHV-1 ICD located in CB103.
- S03-B will require **23.5 m³** of surface storage to restrict flows to a maximum flow rate of **2.0 L/s** via the utilization of a Hydrovex 50VHV-1 ICD located in CB104.

Please refer to Appendix C for all detailed stormwater management calculations.

5.4.2 Quality Control

As discussed in Section 5.1 an oil grit separator (OGS) has been installed downstream of the OHSC storm sewer system that provides water quality treatment prior to entering the municipal sewer network. Therefore, quality control shall not be required at this site. Please see correspondence with the Rideau Valley Conservations Authority (RVCA) in Appendix A.

6 Erosion and Sediment Control

During all construction activities, erosion and sedimentation shall be controlled by the following techniques:

- Extent of exposed soils shall be limited at any given time;
- Exposed areas shall be re-vegetated as soon as possible;
- Minimize the area to be cleared and disruption of adjacent areas;
- Siltsack or approved equivalent shall be installed inside all catch basins, catch basin manholes, and storm manholes as identified on the erosion and sediment control plan;
- Visual inspection shall be completed daily on sediment control barriers and any damage repaired immediately. Care will be taken to prevent damage during construction operations;
- In some cases, barriers may be removed temporarily to accommodate the construction operations. The affected barriers will be reinstated at night when construction is completed;
- Sediment control devices will be cleaned of accumulated silt as required. The deposits will be disposed of as per the requirements of the contract;
- During construction, if the engineer believes that additional prevention methods are required to control erosion and sedimentation, the contractor will install additional silt fences or other methods as required to the satisfaction of the engineer; and,
- Construction and maintenance requirements for erosion and sediment controls are to comply with Ontario Provincial Standard Specification (OPSS) 805.

7 Conclusions

This report provides the sanitary, watermain, and stormwater design for the proposed CHEO parking garage at 401 Smyth Road, in Ottawa, Ontario. This report should be read in conjunction with the engineering drawing package prepared by EXP. The results of the report are as follows:

- The parking garage will be serviced by new 200 mm diameter sanitary sewers which will adequately service the proposed development.
- The parking garage will be serviced by a 200 mm diameter water service which will adequately service the proposed development.
- The parking garage will be serviced by new storm sewers sized to the 5-year storm event which will adequately service the proposed development.
- Stormwater management will be achieved by restricting all storms up to the 100-year event to the allowable release rate. The quantity control criteria for the site is to restrict the 100-year post-development release rate to the 2-year pre-development flow using a runoff coefficient of 0.5, as per the Stormwater Master Plan Study prepared by Morrison Hershfield dated July 2019. This will ensure the proposed development does not adversely affect the downstream system.
- Required on-site storage volumes will be achieved using the surface storage and storage on the top level of the parking garage for storms up to the 100-year event.
- Quality control will be provided by the existing OGS which is located downstream of the OHSC.
- Overland flow routes have been provided for the subject site.
- Temporary erosion and sediment control measures for the subject site have been identified.
- During all construction activities, erosion and sedimentation shall be controlled.

Appendix A – Background Information

- **Figure 1: Site Location Plan**
- **City of Ottawa Pre-Consultation Meeting Notes**
- **Correspondence with Rideau Valley Conservation Authority (RVCA)**

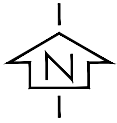

exp Services Inc.
100-2650 Queensview Drive
Ottawa, ON K2B 8H6
www.exp.com



DESIGN ---
DRAWN KH
DATE NOV 2022
FILE NO MRK-21023468

CHEO PARKING GARAGE

SITE LOCATION PLAN

SCALE NTS
SKETCH NO

FIG 1

Date: May 20, 2022

Site Location: 401 Smyth (CHEO)

Type of Development: Residential (townhomes, stacked, singles, apartments),
 Office Space, Commercial, Retail, Institutional, Industrial, other _____

Owner/Agent: CHEO

Assigned Planner: Melanie Gervais

Attendees: _____

Water:

Connection point: Existing private watermain

- Watermain Frontage Fees to be paid (\$190.00 per metre) Yes No

Boundary conditions:

Civil consultant must request boundary conditions from the City's assigned Project Manager prior to submission. Boundary conditions only require the proposed demands (net increase) of the new buildings. The existing and proposed building demands will be required in the modelling upon submission.

- Water boundary condition requests must include the location of the service(s) and the expected loads required by the proposed developments. Please provide all the following information:
 - Location of service(s)
 - Type of development and the amount of fire flow required (as per FUS, 2020).
 - Average daily demand: ___ l/s.
 - Maximum daily demand: ___ l/s.
 - Maximum hourly daily demand: ___ l/s.
- Fire protection (Fire demand, Hydrant Locations)

Sanitary Sewers:

Connection point: Existing private infrastructure

Is a monitoring manhole required on private property? Yes No

- The designer should be aware there may be limited capacity in the downstream sanitary sewer system. The sanitary demand needs to be coordinated with the City Planning Dept. to determine if the existing sanitary sewer system has sufficient capacity to support the proposed rezoning. Provide sanitary demands to the City project manager for coordination.

Storm Sewers:

Connection point: Existing private infrastructure

Storm Water Management:

Quality Control:

- Rideau Valley Conservation Authority to provide quality control requirements for property.

Quantity Control:

- Allowable Runoff coefficient (C): C = the lesser of the existing pre-development conditions to a maximum of 0.5.
- Time of concentration (Tc): Tc = pre-development; maximum Tc = 10 min
- Allowable flowrate: Control the 100-year/5-year storm events to the existing 5-year storm event.

Ministry of Environment, Conservation and Parks (MECEP)

All development applications should be considered for an Environmental Compliance Approval, under MECP regulations.

- The consultants determine if an approval for sewage works under Section 53 of OWRA is required and determines what type of application. The City's project manager may help confirm and coordinate with the MECP as required.
- The project will be either transfer of review (standard), transfer of review (additional), direct submission, or exempt as per O. Reg. 525/98.
- Pre-consultation is not required if applying for standard or additional works (Schedule A of the Agreement) under Transfer Review.
- Pre-consultation with local District office of MECP is recommended for direct submission.

- e. Consultant completes an MECP request form for a pre-consultation. Sends request to moeccottawasewage@ontario.ca
- f. [ECA applications are required to be submitted online through the MECP portal. A business account required to submit ECA application. For more information visit <https://www.ontario.ca/page/environmental-compliance-approval>](#)
- g. [It is unclear if the proposed development will remain as one property. An ECA will be required where the stormwater management services more than one property parcel.](#)

NOTE: Site Plan Approval, or Draft Approval, is required before any Ministry of the Environment and Climate Change (MOECC) application is sent.

General Service Design Comments

- The City of Ottawa requests that all new services be located within the existing service trench to minimize necessary road cuts.
- Monitoring manholes should be located within the property near the property line in an accessible location to City forces and free from obstruction (i.e. not a parking).
- Where service length is greater than 30 m between the building and the first maintenance hole / connection, a cleanout is required.
- The City of Ottawa Standard Detail Drawings should be referenced where possible for all work within the Public Right-of-Way.
- The upstream and downstream manhole top of grate and invert elevations are required for all new sewer connections.

Services crossing the existing watermain or sewers need to clearly provide the obvert/invert elevations to demonstration minimum separation distances. A watermain crossing table may be provided.

All development applications should be considered for an Environmental Compliance Approval (ECA) by the Ministry of the Environment, Conservation, and Parks (MECP);

- a. Consultant determines if an approval for sewage works under Section 53 of OWRA is required. Consultant then determines what type of application is required and the City’s project manager confirms. (If the consultant is not clear if an ECA is required, they will work with the City to determine what is required. If the consultant it is still unclear or there is a difference of opinion only then will the City PM approach the MECP.
- b. The project will be either transfer of review (standard), transfer of review (additional), direct submission, or exempt as per O. Reg. 525/98.
- c. Pre-consultation is not required.
- d. Standard Works ToR Draft ECA’s are sent to the local MECP office (moeccottawasewage@ontario.ca), for information only
- e. Additional ToR draft ECAs require a project summary/design brief and require a response from the local MECP (10 business day window)
- f. **Site Plan Approval, or Draft Approval, will be required before an application is sent to the MECP**

Refer to application tables for lists of required supporting plans and studies– ZONING BY-LAW – Municipal servicing

– SITE PLAN APPLICATION – Municipal servicing

Legend:

- The letter **S** indicates that the study or plan is required with application submission.
- The letter **M** indicates that the study or plan may be required with application submission.

For information on preparing required studies and plans refer to:

<http://ottawa.ca/en/development-application-review-process-0/guide-preparing-studies-and-plans>

| S/A | Number of copies | ENGINEERING | | S/A | Number of copies |
|----------|------------------|--|---|----------|------------------|
| S | 1 | 1. Site Servicing Plan | 2. Assessment of Adequacy of Public Services / Site Servicing Study / Brief | S | 1 |
| S | 1 | 3. Grade Control and Drainage Plan | 4. Geotechnical Study / Slope Stability Study | S | 1 |
| | 1 | 5. Composite Utility Plan | 6. Groundwater Impact Study | | 1 |
| | 1 | 7. Servicing Options Report | 8. Wellhead Protection Study | | 1 |
| | 1 | 9. Community Transportation Study and/or Transportation Impact Study / Brief | 10. Erosion and Sediment Control Plan / Brief | S | 1 |
| S | 1 | 11. Storm water Management Report / Brief | 12. Hydro-geological and Terrain Analysis | | 1 |
| S | 1 | 13. Water main Analysis | 14. Noise / Vibration Study | | 1 |
| | 1 | 15. Roadway Modification Design Plan | 16. Confederation Line Proximity Study | | 1 |

Meeting Date: **2022-May-20**

Application Type: **Site Plan Control**

File Lead: **Mélanie Gervais**

Engineer/Project Manager: **Bruce Bramah**

Site Address: 401 Smyth

*Preliminary Assessment: 1 2 3 4 5

*One (1) indicates that considerable revisions are required before a planning application is submitted, while five (5) suggest that proposal appears to meet the City’s key land use policies and guidelines. This assessment is purely advisory and does not consider technical aspects of the proposal, or in any way guarantee application approval.

It is important to note that the need for additional studies and plans may result during application review. If following the submission of your application, it is determined that material that is not identified in this checklist is required to achieve complete application status, in accordance with the Planning Act and Official Plan requirements, City Planning will notify you of outstanding material required within the required 30 day period. Mandatory pre-application consultation will not shorten the City's standard processing timelines, or guarantee that an application will be approved. It is intended to help educate and inform the applicant about submission requirements as well as municipal processes, policies, and key issues in advance of submitting a formal development application. This list is valid for one year following the meeting date. If the application is not submitted within this timeframe the applicant must again pre-consult with the City.

SITE PLAN APPLICATION – MUNICIPAL SERVICING REQUIRED ENGINEERING STUDIES AND ASSESSMENTS

Notes:

4. Geotechnical Study / Slope Stability Study – required as per Official Plan section 4.8.3. All site plan applications need to demonstrate the soils are suitable for development. A Slope Stability Study may be required with unique circumstances (Schedule K or topography may define slope stability concerns).

10. Erosion and Sediment Control Plan – required with all site plan applications as per Official Plan section 4.7.3.

11. Stormwater Management Report/Brief - required with all site plan applications as per Official Plan section 4.7.6.

14. Noise and Vibration Study – a Noise Study will be required if the noise sensitive development is proposed within 250 metres of an existing or proposed highway or a railway right-of-way, or 100 metres of an arterial or collector roadway or rapid-transit corridor. A Vibration Study will be required if the proposed development is within 75 metres of either an existing or proposed railway ROW. A Noise Study may also be required if the proposed development is adjacent to an existing or proposed stationary noise source.

35. An Impact Assessment of an Adjacent Waste Disposal/Former Landfill Site study is required for development proposals within 500 metres of a solid waste disposal site or other appropriate influence area or former landfill site. For contaminated sites a Record of Site Condition or letter of continued use is required.

39.A Mineral Resource Impact Assessment study is required, as per Official Plan section 3.7.4 adjacent to an unlicensed Limestone Resource or Sand and Gravel Resource Area (very limited uses considered within 500 metres of Limestone Resource Area or 300 metres of Sand and Gravel Resource Area). A study is required

- adjacent to, or within 300 metres of, a licensed pit
- adjacent to, or within 500 metres of, a licensed quarry

Karlinda Hinds

From: Jamie Batchelor <jamie.batchelor@rvca.ca>
Sent: Monday, November 28, 2022 11:50 AM
To: Karlinda Hinds
Cc: Alam Ansari; Amr Salem
Subject: RE: CHEO Parking Garage & 1Door4Care - SWM Quality Control

Follow Up Flag: Follow up
Flag Status: Flagged



CAUTION: This email originated from outside of the organization. Do not click links or open attachments unless you recognize the sender and know the content is safe.

Good Morning Karlinda,

If you can confirm that the OGS installed does treat the runoff from this site, and is sized to accommodate the additional flows for a water quality target of 80% TSS removal, then the RVCA would not require any additional on-site water quality control. We would encourage that any stormwater management strategy consider the implementation of LIDs with a focus on maintaining the existing hydrology of the site.

Jamie Batchelor, MCIP, RPP
Planner, ext. 1191
Jamie.batchelor@rvca.ca



3889 Rideau Valley Drive
PO Box 599, Manotick ON K4M 1A5
T 613-692-3571 | 1-800-267-3504 F 613-692-0831 | www.rvca.ca

This message may contain information that is privileged or confidential and is intended to be for the use of the individual(s) or entity n: may contain confidential or personal information which may be subject to the provisions of the *Municipal Freedom of Information & F* you are not the intended recipient of this e-mail, any use, review, revision, retransmission, distribution, dissemination, copying, printing taking of any action in reliance upon this e-mail, is strictly prohibited. If you have received this e-mail in error, please contact the send and any copy of the e-mail and any printout thereof, immediately. Your cooperation is appreciated.

From: Karlinda Hinds <Karlinda.Hinds@exp.com>
Sent: Wednesday, November 23, 2022 3:11 PM
To: Jamie Batchelor <jamie.batchelor@rvca.ca>
Cc: Alam Ansari <alam.ansari@exp.com>; Amr Salem <Amr.Salem@exp.com>
Subject: CHEO Parking Garage & 1Door4Care - SWM Quality Control

Good afternoon Jamie,

I hope this email finds you well.

We are working on the Site Plan Control application for a new parking garage at the Ottawa Hospital Sciences Center (OHSC) campus at 401 Smyth Road. In addition to the parking garage, a new CHEO facility called 1Door4Care is also proposed to be constructed on the OHSC campus. I have attached a site location plan for your reference.

Can you please confirm the stormwater quality control requirements for these two developments? Based on background information we have reviewed there was an oil grit separator installed as part of the Alta Vista Hospital Link (AVHL) project which provides water quality treatment of stormwater discharge from the OHSC campus. Therefore, it is our understanding that quality control may not be required for these sites.

If you have any questions or require more information please let me know.

Thanks,



Karlinda Hinds, P.Eng.

EXP | Project Manager

t : +1.613.688.1899, 63252 | m : +1.613.795.5159 | e : karlinda.hinds@exp.com

2650 Queensview Drive

Suite 100

Ottawa, ON K2B 8H6

CANADA

exp.com | [legal disclaimer](#)

keep it green, read from the screen

Appendix B – Watermain Design

- **FUS 2020 Calculations**
- **Water Demand Calculations**
- **Boundary Conditions**
- **Pressure Calculation Sheet**
- **Figure 2 – Hydrant Location Plan**
- **Hydrant Flow Calculations**

TABLE B1: FIRE FLOW REQUIREMENTS BASED ON FIRE UNDERWRITERS SURVEY(FUS) 2020

PROJECT: Parking Garage
 Building No: **CHEO Parking Garage**



An estimate of the Fire Flow required for a given fire area may be estimated by:

$$F = 220 * C * \text{SQRT}(A)$$

where:

F = required fire flow in litres per minute
 A = total floor area in m² (including all storeys, but excluding basement)
 C = coefficient related to the type of construction

For open air parking garages, the 2020 FUS method determines the total effective floor area as the largest floor. Please revise.

PDC Response: Noted. This is to be reflected in ProjectCo's fire flow design calculations.

| Task | Options | Multiplier | | | Fire Flow Total (L/min) |
|--------------------------------|---|------------|------------------------------|------------------------|-------------------------|
| Choose Building Frame (C) | Wood Frame | 1.5 | Non-combustible Construction | 0.8 | |
| | Ordinary Construction | 1 | | | |
| | Non-combustible Construction | 0.8 | | | |
| | Fire Resistive Construction | 0.6 | | | |
| Input Building Floor Areas (A) | Seventh Floor | | 2419 | 21766.5 m ² | |
| | Sixth Floor | | 2419 | | |
| | Fifth Floor | | 2419 | | |
| | Fourth Floor | | 2419 | | |
| | Third Floor | | 2419 | | |
| | Second Floor | | 4837 | | |
| | First Floor | | 4837 | | |
| | Basement (At least 50% below grade, not included) | | 0 | | |
| Fire Flow (F) | F = 220 * C * SQRT(A) | | | | 25,966 |
| Fire Flow (F) | Rounded to nearest 1,000 | | | | 26,000 |

Reductions/Increases Due to Factors Effecting Burning

| Task | Options | Multiplier | Input | Value Used | Fire Flow Change (L/min) | Fire Flow Total (L/min) | | | | | | | | | | | | | | |
|--|--|---------------------|--|----------------------|--------------------------|-------------------------|---------------|----------------------|---------------|------------|------------------|-------------------------------|------|---|------|---|----|----|---|--------|
| Choose Combustibility of Building Contents | Non-combustible | -25% | Combustible | 0% | 0 | 26,000 | | | | | | | | | | | | | | |
| | Limited Combustible | -15% | | | | | | | | | | | | | | | | | | |
| | Combustible | 0% | | | | | | | | | | | | | | | | | | |
| | Free Burning | 15% | | | | | | | | | | | | | | | | | | |
| | Rapid Burning | 25% | | | | | | | | | | | | | | | | | | |
| Choose Reduction Due to Sprinkler System | Adequate Sprinkler Conforms to NFPA13 | -30% | Adequate Sprinkler Conforms to NFPA13 | -30% | -7,800 | 18,200 | | | | | | | | | | | | | | |
| | No Sprinkler | 0% | Standard Water Supply for Fire Department Hose Line and for Sprinkler System | -10% | -2,600 | 15,600 | | | | | | | | | | | | | | |
| | Standard Water Supply for Fire Department Hose Line and for Sprinkler System | -10% | | | | | | | | | | | | | | | | | | |
| | Not Standard Water Supply or Unavailable | 0% | | | | | | | | | | | | | | | | | | |
| | Fully Supervised Sprinkler System | -10% | Fully Supervised Sprinkler System | -10% | -2,600 | 13,000 | | | | | | | | | | | | | | |
| Not Fully Supervised or N/A | 0% | | | | | | | | | | | | | | | | | | | |
| Choose Structure Exposure Distance | Exposures | Separation Dist (m) | Cond | Separation Condition | Exposed Wall type | Exposed Wall Length | | | | | Total Charge (%) | Total Exposure Charge (L/min) | | | | | | | | |
| | | | | | | Length (m) | No of Storeys | Length-Height Factor | Sub-Condition | Charge (%) | | | | | | | | | | |
| | | | | | | Side 1 (West) | 40 | 5 | 30.1 to 45 | Type V | | | 12.1 | 2 | 24.2 | 6 | 0% | 0% | 0 | 13,000 |
| | | | | | | Side 2 (East) | 40 | 5 | 30.1 to 45 | Type V | | | 0 | 0 | 0 | 6 | 0% | | | |
| | | | | | | Front (South) | 40 | 5 | 30.1 to 45 | Type V | | | 76 | 4 | 304 | 6 | 0% | | | |
| Back (North) | 40 | 5 | 30.1 to 45 | Type V | 86.5 | 8 | 692 | 6 | 0% | | | | | | | | | | | |
| Obtain Required Fire Flow | Total Required Fire Flow, Rounded to the Nearest 1,000 L/min = | | | | | | | | | | 13,000 | | | | | | | | | |
| | Total Required Fire Flow, L/s = | | | | | | | | | | 216.7 | | | | | | | | | |

Exposure Charges for Exposing Walls of Wood Frame Construction (from Table G5)

- Type V Wood Frame
- Type IV-III (U) Mass Timber or Ordinary with Unprotected Openings
- Type IV-III (P) Mass Timber or Ordinary with Protected Openings
- Type II-I (U) Noncombustible or Fire Resistive with Unprotected Openings
- Type II-I (P) Noncombustible or Fire Resistive with Protected Openings

Conditions for Separation

| Separation Dist | Condition |
|-----------------|-----------|
| 0m to 3m | 1 |
| 3.1m to 10m | 2 |
| 10.1m to 20m | 3 |
| 20.1m to 30m | 4 |
| > 30.1m | 5 |

Karlinda Hinds

From: Simon Branch <simonbranch@bty.com>
Sent: Wednesday, November 16, 2022 11:24 AM
To: Mark LONGO
Cc: Alam Ansari; Behram Dubash; Jonathan Ching; Jerry CHLEBOWSKI; Simon Branch; Jeff Moloney; Karlinda Hinds; Aaditya Jariwala
Subject: FW: 12445 CHEO: Parking Garage - Water Boundary Conditions
Attachments: 401 Smyth Road November 2022.pdf

Follow Up Flag: Follow up
Flag Status: Completed

Some people who received this message don't often get email from simonbranch@bty.com. [Learn why this is important](#)



CAUTION: This email originated from outside of the organization. Do not click links or open attachments unless you recognize the sender and know the content is safe.

Hey Mark,

Please see attached and below.

Regards,



Simon Branch

Director

T: (343) 997-3851 E: simonbranch@bty.com

From: Bramah, Bruce <bruce.bramah@ottawa.ca>
Sent: Wednesday, November 16, 2022 8:47 AM
To: Simon Branch <simonbranch@bty.com>
Cc: Gervais, Melanie <Melanie.Gervais@ottawa.ca>
Subject: RE: 12445 CHEO: Parking Garage - Water Boundary Conditions

[External Email]

Good morning Simon,

Sorry for the delayed response, our modelling team is currently experience a large volume of requests. Based on the service connection location to the existing private watermain and the low fire flow compared to the remaining hospital site, we will not require hydraulic modelling for this application. In the design brief, please provide a brief description of the proposed service and existing private watermain. Please also confirm the pressures at the FFE based on the boundary conditions below.

The following are boundary conditions, HGL, for hydraulic analysis at 401 Smyth Road (zone 2W2C) assumed to be a connected at the public 305 mm watermain on Smyth Road (see attached PDF for location).

Min HGL: 123.7 m

Max HGL: 131.5 m

Max Day + FF (217 L/s): 116.1 m

These are for current conditions and are based on computer model simulation.

Disclaimer: The boundary condition information is based on current operation of the city water distribution system. The computer model simulation is based on the best information available at the time. The operation of the water distribution system can change on a regular basis, resulting in a variation in boundary conditions. The physical properties of watermains deteriorate over time, as such must be assumed in the absence of actual field test data. The variation in physical watermain properties can therefore alter the results of the computer model simulation.

If you have any questions, please feel free to contact me.

Thank you,

--

Bruce Bramah, EIT

Project Manager

Planning, Real Estate and Economic Development Department / Direction générale de la planification, des biens immobiliers et du développement économique

Development Review - South Branch

City of Ottawa | Ville d'Ottawa

110 Laurier Avenue West Ottawa, ON | 110, avenue. Laurier Ouest. Ottawa (Ontario) K1P 1J1

613.580.2424 ext./poste 29686, Bruce.Bramah@ottawa.ca

From: Gervais, Melanie <Melanie.Gervais@ottawa.ca>

Sent: October 24, 2022 3:51 PM

To: Bramah, Bruce <bruce.bramah@ottawa.ca>

Subject: FW: 12445 CHEO: Parking Garage - Water Boundary Conditions

Hi Bruce,

Would you be able to provide a response and cc me?

Mélanie Gervais MCIP, RPP

Planner III (A) / Urbaniste III (i)

Development Review - South /

Examen des demandes d'aménagement - sud

Planning, Real Estate and Economic Development Department /

Direction générale de la planification, des biens immobiliers et du développement économique

City of / Ville d'Ottawa

110, avenue Laurier Avenue West / Ouest,

4th Floor / 4ième étage

Ottawa, ON K1P 1J1

Tel. : 613-580-2424 ext. 24025

Cell. : 613-282-0508

E-mail / Courriel : Melanie.Gervais@ottawa.ca

Mail Code: 01-14

**Please note that I'm working from home during the COVID-19 pandemic.*

From: Simon Branch <simonbranch@bty.com>
Sent: October 20, 2022 4:30 PM
To: Gervais, Melanie <Melanie.Gervais@ottawa.ca>
Cc: Mark LONGO <Mark.Longo@bharchitects.com>; Jerry CHLEBOWSKI <Jerry.Chlebowski@bharchitects.com>
Subject: 12445 CHEO: Parking Garage - Water Boundary Conditions

Good day Melanie,

I've been asked to pass this question below from EXP to the City. Would you prefer communications such as this to pass through you or can it be done directly between engineers?

"Can you please provide the water boundary conditions for the new parking garage given the below information?"

The attached map identifies the approximate location of the parking garage and the connection to the existing 300mm private watermain.

The following are the water demands for the proposed parking garage:

Average daily demand: **0.16 L/sec**

Max. daily demand: **0.24 L/sec**

Peak Hour demand: **0.43 L/sec**

Fire flow demand as per FUS 2020: **217 L/sec**

The following was taken from the pre-consultation engineering notes:

Civil consultant must request boundary conditions from the City's assigned Project Manager prior to submission. Boundary conditions only require the proposed demands (net increase) of the new buildings. **existing and proposed building demands will be required in the modelling upon submission.**

Can you please confirm which existing demands are required in the modelling?

If there are any questions or comments please let us know."

Cheers,



Simon Branch

Director

T: (343) 997-3851 E: simonbranch@bty.com



CAREERS

This email may be confidential and protected by legal privilege. If you are not the intended addressee you may not share any part of this message with any third party. If you received this email by error, please destroy this message and kindly notify the sender by reply email. [v201701]

This e-mail originates from the City of Ottawa e-mail system. Any distribution, use or copying of this e-mail or the information it contains by other than the intended recipient(s) is unauthorized. Thank you.

Le présent courriel a été expédié par le système de courriels de la Ville d'Ottawa. Toute distribution, utilisation ou reproduction du courriel ou des renseignements qui s'y trouvent par une personne autre que son destinataire prévu est interdite. Je vous remercie de votre collaboration.

Boundary Conditions for 401 Smyth Road

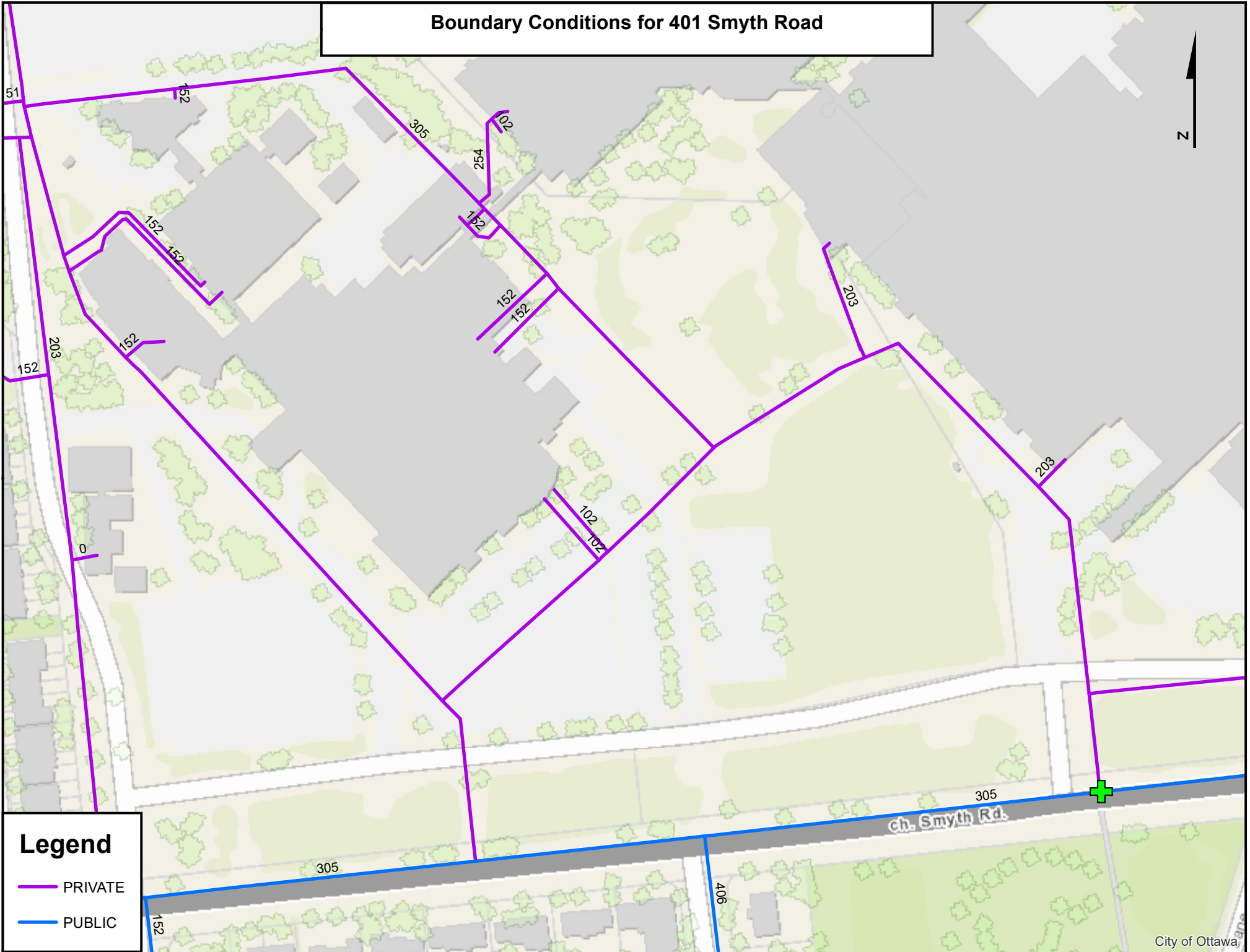

Legend

-  PRIVATE
-  PUBLIC

**TABLE B3
ESTIMATED WATER PRESSURE AT PROPOSED BUILDING**

| Description | From | To | Demand (L/sec) | Pipe Length (m) | Pipe Dia (mm) | Dia (m) | Slope of HGL (m/m) | Head Loss (m) | Elev From (m) | Elev To (m) | *Elev Diff (m) | Pressure From kPa (psi) | Pressure To kPa (psi) | Pressure Drop (psi) | | | | | | | | | | | | | | | | | | |
|--|---|----------------|---------------------|--|---------------|---------|--------------------|---------------|---------------|-------------|----------------|-------------------------|-----------------------|---------------------|--------------------------|---------------------|-----------------------------|-----------------------------------|-----------------------------|---|-----------------------------|---|------|-------------------|------------------------------------|------------|--------------------------------------|---------------------------------------|--|--|--|---------------------------|
| Average Day Conditions | | | | | | | | | | | | | | | | | | | | | | | | | | | | | | | | |
| 300mm existing water main | Smyth Road | East of PG | 0.160 | 123 m | 300 | 0.300 | 5.82E-08 | 7E-06 | 82.50 | 81.50 | 1.0 | 480.7 (69.7) | 490.5 (71.1) | -1.42 | | | | | | | | | | | | | | | | | | |
| 200mm Service | East of PG | FFE | 0.160 | 30.0 m | 200 | 0.200 | 4.19E-07 | 1E-05 | 81.50 | 83.00 | -1.5 | 490.5 (71.1) | 475.8 (69.0) | 2.1 | | | | | | | | | | | | | | | | | | |
| Max Day Conditions | | | | | | | | | | | | | | | | | | | | | | | | | | | | | | | | |
| 300mm existing water main | Smyth Road | East of PG | 0.240 | 123 m | 300 | 0.300 | 1.23E-07 | 2E-05 | 82.50 | 81.50 | 1.0 | 404.2 (58.6) | 414.0 (60.0) | -1.42 | | | | | | | | | | | | | | | | | | |
| 200mm Service | East of PG | FFE | 0.240 | 30.0 m | 200 | 0.200 | 8.88E-07 | 3E-05 | 81.50 | 83.00 | -1.5 | 414.0 (60.0) | 399.3 (57.9) | 2.1 | | | | | | | | | | | | | | | | | | |
| Peak Hour Conditons | | | | | | | | | | | | | | | | | | | | | | | | | | | | | | | | |
| 300mm existing water main | Smyth Road | East of PG | 0.432 | 123 m | 300 | 0.300 | 3.66E-07 | 5E-05 | 82.50 | 81.50 | 1.0 | 404.2 (58.6) | 414.0 (60.0) | -1.42 | | | | | | | | | | | | | | | | | | |
| 200mm Service | East of PG | FFE | 0.432 | 30.0 m | 200 | 0.200 | 2.64E-06 | 8E-05 | 81.50 | 83.00 | -1.5 | 414.0 (60.0) | 399.3 (57.9) | 2.1 | | | | | | | | | | | | | | | | | | |
| Sprinkler Demand | | | | | | | | | | | | | | | | | | | | | | | | | | | | | | | | |
| 300mm existing water main | Smyth Road | East of PG | 32.000 | 123 m | 300 | 0.300 | 0.00106 | 0.1304 | 82.50 | 81.50 | 1.0 | 392.3 (56.9) | 400.8 (58.1) | -1.24 | | | | | | | | | | | | | | | | | | |
| 200mm Service | East of PG | FFE | 32.000 | 30.0 m | 200 | 0.200 | 0.007637 | 0.2291 | 81.50 | 83.00 | -1.5 | 400.8 (58.1) | 383.9 (55.7) | 2.5 | | | | | | | | | | | | | | | | | | |
| Max Day + FF | | | | | | | | | | | | | | | | | | | | | | | | | | | | | | | | |
| 300mm existing water main | Smyth Road | East of PG | 216.907 | 123 m | 300 | 0.300 | 0.036692 | 4.5131 | 82.50 | 81.50 | 1.0 | 329.6 (47.8) | 295.2 (42.8) | 5.00 | | | | | | | | | | | | | | | | | | |
| <table border="0" style="width: 100%;"> <tr> <td style="width: 50%;">Water Demand Info</td> <td style="width: 50%;">Pipe Lengths</td> </tr> <tr> <td>Average Demand = 0.16 L/sec</td> <td>From watermain to building = 30 m</td> </tr> <tr> <td>Max Day Demand = 0.24 L/sec</td> <td>From mech room to centre top floor = 21.7 m</td> </tr> <tr> <td>Peak Hr Demand = 0.43 L/sec</td> <td>Hazen Williams C Factor for Friction Loss in Pipe, C= 110</td> </tr> <tr> <td> </td> <td>Elevations</td> </tr> <tr> <td>Fireflow Requirement = 216.7 L/sec</td> <td>At roadway</td> </tr> <tr> <td>Max Day Plus FF Demand = 216.9 L/sec</td> <td>(Proposed Service Connection) = 81.50</td> </tr> <tr> <td></td> <td>At boundary condition along Smyth Road = 82.50</td> </tr> <tr> <td></td> <td>At building (FFE) = 83.00</td> </tr> </table> | | | | | | | | | | | | | | | Water Demand Info | Pipe Lengths | Average Demand = 0.16 L/sec | From watermain to building = 30 m | Max Day Demand = 0.24 L/sec | From mech room to centre top floor = 21.7 m | Peak Hr Demand = 0.43 L/sec | Hazen Williams C Factor for Friction Loss in Pipe, C= 110 | | Elevations | Fireflow Requirement = 216.7 L/sec | At roadway | Max Day Plus FF Demand = 216.9 L/sec | (Proposed Service Connection) = 81.50 | | At boundary condition along Smyth Road = 82.50 | | At building (FFE) = 83.00 |
| Water Demand Info | Pipe Lengths | | | | | | | | | | | | | | | | | | | | | | | | | | | | | | | |
| Average Demand = 0.16 L/sec | From watermain to building = 30 m | | | | | | | | | | | | | | | | | | | | | | | | | | | | | | | |
| Max Day Demand = 0.24 L/sec | From mech room to centre top floor = 21.7 m | | | | | | | | | | | | | | | | | | | | | | | | | | | | | | | |
| Peak Hr Demand = 0.43 L/sec | Hazen Williams C Factor for Friction Loss in Pipe, C= 110 | | | | | | | | | | | | | | | | | | | | | | | | | | | | | | | |
| | Elevations | | | | | | | | | | | | | | | | | | | | | | | | | | | | | | | |
| Fireflow Requirement = 216.7 L/sec | At roadway | | | | | | | | | | | | | | | | | | | | | | | | | | | | | | | |
| Max Day Plus FF Demand = 216.9 L/sec | (Proposed Service Connection) = 81.50 | | | | | | | | | | | | | | | | | | | | | | | | | | | | | | | |
| | At boundary condition along Smyth Road = 82.50 | | | | | | | | | | | | | | | | | | | | | | | | | | | | | | | |
| | At building (FFE) = 83.00 | | | | | | | | | | | | | | | | | | | | | | | | | | | | | | | |
| Boundary Conditon by the City: | | | | | | | | | | | | | | | | | | | | | | | | | | | | | | | | |
| | <u>Min HGL</u> | <u>Max HGL</u> | <u>Max Day + FF</u> | | | | | | | | | | | | | | | | | | | | | | | | | | | | | |
| HGL (m) | 123.7 | 131.5 | 116.1 | <----- (From City of Ottawa at Smyth Road) | | | | | | | | | | | | | | | | | | | | | | | | | | | | |
| Approx Ground Elev (m) = | 82.50 | 82.50 | 82.50 | | | | | | | | | | | | | | | | | | | | | | | | | | | | | |
| Pressure (m) = | 41.2 | 49 | 33.6 | | | | | | | | | | | | | | | | | | | | | | | | | | | | | |
| Pressure (Pa) = | 404,172 | 480,690 | 329,616 | | | | | | | | | | | | | | | | | | | | | | | | | | | | | |
| Pressure (psi) = | 58.6 | 69.7 | 47.8 | | | | | | | | | | | | | | | | | | | | | | | | | | | | | |

File: \\exp\data\MRK\MRK-21023468-A0\60 Execution\65 Drawings\Temp Civil\Conceptual Design Drawings\21023468 - Figures.dwg
 Last Saved: Dec 12, 2022 3:15 PM Last Plotted: Dec 12, 2022 3:16 PM Plotted by: Hinds

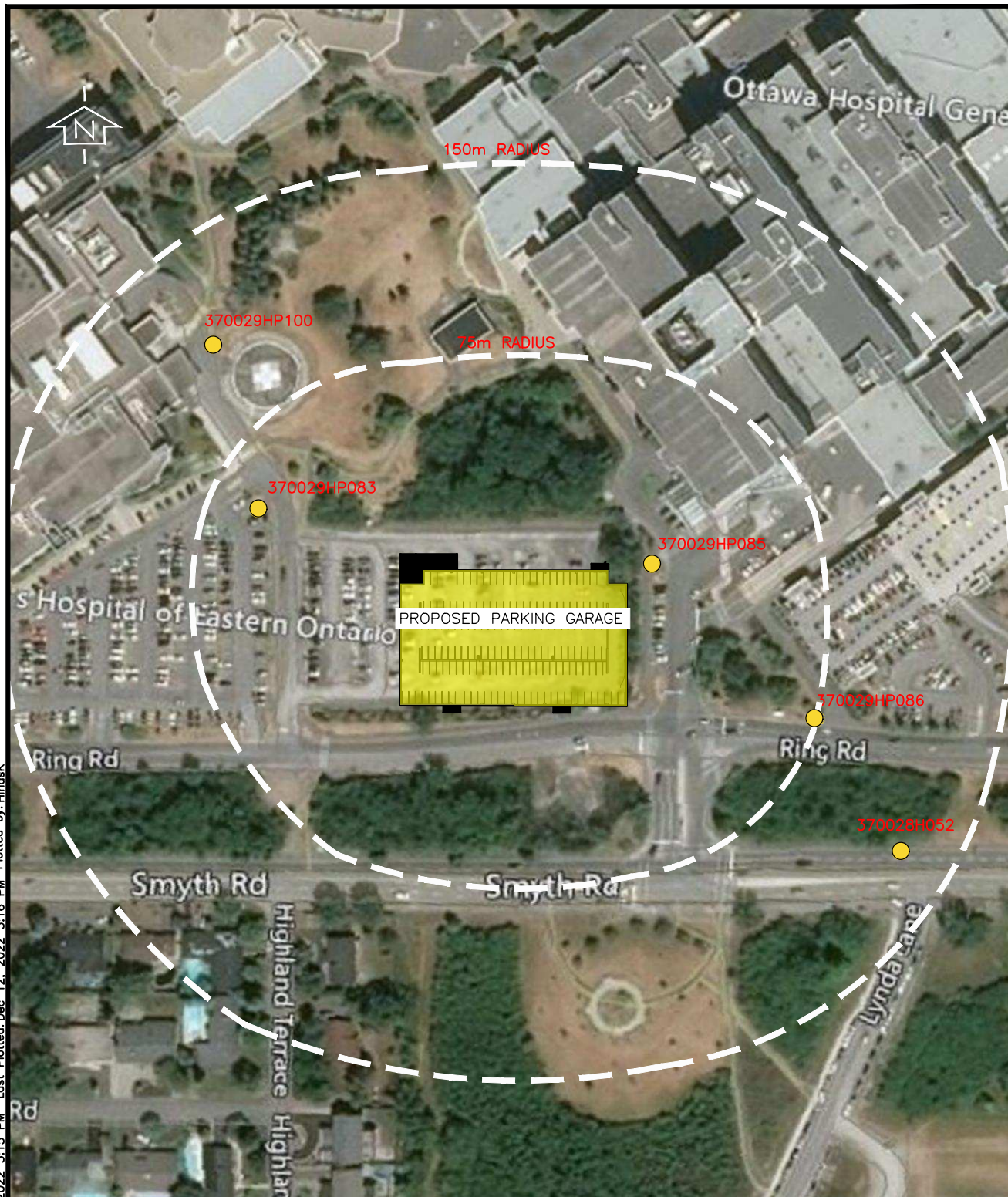

| | | | | | | |
|--|--|---------|--------------|----------------------------|------------------------------|-----------|
| exp Services Inc. 100-2650 Queensview Drive Ottawa, ON K2B 8H6 www.exp.com | | DESIGN | --- | CHEO PARKING GARAGE | SCALE | 1:2000 |
| | | DRAWN | AJ | | HYDRANT LOCATION PLAN | SKETCH NO |
| | | DATE | NOV 2022 | FIG 2 | | |
| | | FILE NO | MRK-21023468 | | | |

TABLE B4

AVAILABLE FIRE FLOWS BASED ON HYDRANT SPACING

| Hydrant # | Location | City / Private | Color Code | Accessible (yes/no) | Parking Garage PH 1A | |
|---|-------------------------------|----------------|------------|---------------------|-----------------------|--|
| | | | | | ¹ Dist (m) | ² Fire Flow Contrib (L/min) |
| 370029HP100 | CHEO East Entrance | PRIVATE | BLUE | Yes | 126 | 3,800 |
| 370029HP083 | CHEO East Entrance | PRIVATE | BLUE | Yes | 50 | 5,700 |
| 370029HP085 | Ottawa Hospital West Entrance | PRIVATE | BLUE | Yes | 50 | 5,700 |
| 370029HP086 | Ring Road | PRIVATE | BLUE | Yes | 65 | 5,700 |
| 370028H052 | Smyth Road | CITY | BLUE | Yes | 140 | 3,800 |
| Total (L/min) | | | | | | 24,700 |
| Total (L/sec) | | | | | | 412 |
| FUS RFF in L/min | | | | | | 217 |
| Meets Requirement (Yes/No) | | | | | | Yes |
| Notes: | | | | | | |
| 1) Distance is measured along a road or fire route. | | | | | | |
| 2) Fire Flow Contribution for Class AA Hydrant from Table 1 of Appendix I, ISTB-2018-02 | | | | | | |

Appendix C – Stormwater Design

- **Storm Sewer Design Sheet**
- **Stormwater Management Calculations**
- **Hydrovex Vertical Vortex ICD Curves**

TABLE C1
STORM SEWER CALCULATION SHEET

Return Period Storm = 5-year
 Default Inlet Time = 10
 Manning Coefficient = 0.013

| Street | Storm MH No: | | AREA INFO | | | | PEAK FLOWS (UNRESTRICTED - RATIONAL METHOD) | | | | | | | Indiv Captured Flows (L/sec) | Cumul Captured Flows (L/sec) | SEWER DATA | | | | | | | | | | | | | | | | | | | | | |
|--|--------------|-----------|---------------|---------------|------------------|-----------------|---|-----------------|-----------|----------|-------------|---|---------|------------------------------|------------------------------|---------------|-----|------|-----------|------------|------------------------------------|----------------|------|------------------------|--------------------|-----------------------------------|---------|-------|-------|--------|---------|-------|-------|----------|----------|-------|-------|
| | U/S | D/S | Catchment No: | Area (ha) | Accum. Area (ha) | Runoff Coeff, C | Indiv. 2.78*A*R | Accum. 2.78*A*R | Tc (mins) | I (mm/h) | Indiv. Flow | Return Period | Q (L/s) | | | Diameter (mm) | | Type | Slope (%) | Length (m) | Capacity, Q _{CAP} (L/sec) | Velocity (m/s) | | Time in Pipe, Tt (min) | Hydraulic Ratios | | | | | | | | | | | | |
| | | | | | | | | | | | | | | | | Act | Nom | | | | | Vf | Va | | Q/Q _{CAP} | Q _{CD} /Q _{CAP} | Va/Vf | | | | | | | | | | |
| | Roof | STMMH 301 | S02 | 0.4840 | 0.4840 | 0.90 | 1.2110 | 1.2110 | 10.00 | 104.19 | 126.17 | 5-year | 126.17 | 37.64 | 366.4 | 375 | PVC | 2.02 | 5.4 | 234.28 | 2.26 | 1.60 | 0.06 | 0.54 | 0.16 | 0.71 | | | | | | | | | | | |
| | CB04 | STMMH 301 | S03-B | 0.0550 | 0.0550 | 0.90 | 0.1376 | 0.1376 | 10.00 | 104.19 | 14.34 | 5-year | 14.34 | 2.00 | 201.2 | 200 | PVC | 1.00 | 7.2 | 33.31 | 1.04 | 0.74 | 0.16 | 0.43 | 0.06 | 0.71 | | | | | | | | | | | |
| | | STMMH 301 | STMMH 302 | | 0.5390 | | | 1.3486 | 10.16 | 103.34 | | 5-year | 139.36 | 39.64 | 366.4 | 375 | PVC | 1.50 | 0.9 | 201.88 | 1.94 | 1.85 | 0.01 | 0.69 | 0.20 | 0.95 | | | | | | | | | | | |
| | CB 103 | STMMH 302 | S03-A | 0.0530 | 0.0530 | 0.81 | 0.1193 | 0.1193 | 10.00 | 104.19 | 12.43 | 5-year | 12.43 | 6.00 | 6.00 | 201.2 | 200 | PVC | 2.15 | 4.7 | 48.84 | 1.53 | 1.03 | 0.08 | 0.25 | 0.12 | 0.67 | | | | | | | | | | |
| | CB101 | STMMH 302 | S01-A & S01-B | 0.2950 | 0.2950 | 0.35 | 0.2870 | 0.2870 | 10.00 | 104.19 | 29.91 | 5-year | 29.91 | 8.00 | 8.00 | 251.5 | 250 | PVC | 1.00 | 55.3 | 60.40 | 1.21 | 0.86 | 1.08 | 0.50 | 0.13 | 0.71 | | | | | | | | | | |
| | | STMMH 302 | EX. STM MH24 | | 0.8870 | | | 1.7550 | 10.17 | 103.30 | | 5-year | 181.74 | 53.64 | 447.9 | 450 | PVC | 1.00 | 6.9 | 281.52 | 1.79 | 1.65 | 0.07 | 0.65 | 0.19 | 0.92 | | | | | | | | | | | |
| TOTALS = | | | | 0.8870 | | 0.71 | 1.7550 | | | | | | | 53.64 | | | | | | | | | | | | | | | | | | | | | | | |
| Definitions: | | | | | | | | | | | | Designed: _____ Project: _____ A.Salem, P.Eng. CHEO Parking Garage Checked: _____ Location: _____ K.Hinds, P.Eng. CHEO Parking Garage Dwg Reference: _____ File Ref: _____ Sheet No: _____ Drawing C400 21023468 - Storm - Sewer Design Sheets.xlsx 1 of 1 | | | | | | | | | | | | | | | | | | | | | | | | | |
| Q = 2.78*AIR, where Q = Peak Flow in Litres per second (L/s) A = Watershed Area (hectares) I = Rainfall Intensity (mm/h) R = Runoff Coefficients (dimensionless) | | | | | | | | | | | | Ottawa Rainfall Intensity Values from Sewer Design Guidelines, SDG002 <table border="1"> <thead> <tr> <th></th> <th>a</th> <th>b</th> <th>c</th> </tr> </thead> <tbody> <tr> <td>2-year</td> <td>732.951</td> <td>6.199</td> <td>0.810</td> </tr> <tr> <td>5-year</td> <td>998.071</td> <td>6.053</td> <td>0.814</td> </tr> <tr> <td>100-year</td> <td>1735.688</td> <td>6.014</td> <td>0.820</td> </tr> </tbody> </table> | | | | | | | | | | | a | b | c | 2-year | 732.951 | 6.199 | 0.810 | 5-year | 998.071 | 6.053 | 0.814 | 100-year | 1735.688 | 6.014 | 0.820 |
| | a | b | c | | | | | | | | | | | | | | | | | | | | | | | | | | | | | | | | | | |
| 2-year | 732.951 | 6.199 | 0.810 | | | | | | | | | | | | | | | | | | | | | | | | | | | | | | | | | | |
| 5-year | 998.071 | 6.053 | 0.814 | | | | | | | | | | | | | | | | | | | | | | | | | | | | | | | | | | |
| 100-year | 1735.688 | 6.014 | 0.820 | | | | | | | | | | | | | | | | | | | | | | | | | | | | | | | | | | |

TABLE C2: CALCULATION OF AVERAGE RUNOFF COEFFICIENTS FOR PRE-DEVELOPMENT CONDITONS

| Area No. | Concrete / Pavers | | Gravel | | Grassed Areas | | Sum AC | Total Area (m ²) | C _{AVG} | Comments |
|--------------|------------------------|-------|------------------------|----------------|------------------------|-------|----------------|------------------------------|------------------|----------|
| | C=0.90 | | C=0.75 | | C=0.20 | | | | | |
| | Area (m ²) | A * C | Area (m ²) | A * C | Area (m ²) | A * C | | | | |
| E1 | | | 11224.80 | 8418.6 | | | 8418.6 | 11224.80 | 0.75 | |
| Total | | | 11224.80 | 8418.60 | | | 8418.60 | 11224.80 | 0.75 | |

TABLE C3: ESTIMATION OF ALLOWABLE PEAK FLOWS (Based on Max C=0.50 with Tc=10mins & 2-yr Storm)

| Area No | Outlet Location | Area (ha) | Time of Conc, Tc (min) | Storm = 2 yr | | | Storm = 5 yr | | | Storm = 100 yr | | |
|--------------|----------------------|-------------|------------------------|------------------------|------|----------------------------|------------------------|------|----------------------------|--------------------------|------|----------------------------|
| | | | | I ₂ (mm/hr) | Cavg | Q _{ALLOW} (L/sec) | I ₅ (mm/hr) | Cavg | Q _{ALLOW} (L/sec) | I ₁₀₀ (mm/hr) | Cavg | Q _{ALLOW} (L/sec) |
| E1 | Existing Parking Lot | 1.12 | 10 | 76.81 | 0.50 | 119.83 | 104.19 | 0.50 | 162.57 | 178.56 | 0.63 | 348.25 |
| Total | | 1.12 | | | | 119.83 | | | 162.57 | | | 348.25 |

Notes

- 1) Intensity, I = 732.951/(Tc+6.199)^{0.810} (2-year, City of Ottawa)
- 2) Intensity, I = 998.071/(Tc+6.053)^{0.814} (5-year, City of Ottawa)
- 3) Intensity, I = 1735.688/(Tc+6.014)^{0.820} (100-year, City of Ottawa)
- 4) Cavg for 100-year is increased by 25% to a maximum of 1.0
- 5) Allowable Capture Rate is based on 2-year storm at Tc=10 min or calculated value greater than 10 and maximum Cavg=0.5

Allowable Discharge (based on 2-yr storm)

TABLE C4: AVERAGE RUNOFF COEFFICIENTS FOR POST-DEVELOPMENT CONDITIONS

| C _{ASPH/CONC} = 0.90 C _{ROOF} = 0.90 C _{GRASS} = 0.20 C _{PERM-STONES} = 0.40 | | | | | | | | | | | | |
|---|--|-----------------------|------------------------------|-----------------------|---------------------------------|------------------------|---|------------------------------|----------------|------------------------------|-----------------------------|---------|
| Area No. | Asphalt & Conc Areas (m ²) | A * C _{ASPH} | Roof Areas (m ²) | A * C _{ROOF} | Grassed Areas (m ²) | A * C _{GRASS} | Permeable Pavers Area (m ²) | A * C _{PERM-STONES} | Sum AC | Total Area (m ²) | C _{AVG} (see note) | Comment |
| S01-A | 308.00 | 277.20 | | | 1252.00 | 250.40 | | | 527.60 | 1560.00 | 0.34 | |
| S01-B | 307.00 | 276.30 | | | 1080.00 | 216.00 | | | 492.30 | 1387.00 | 0.35 | |
| S02 - BLDG | | | 4837.00 | 4353.30 | | | | | 4353.30 | 4837.00 | 0.90 | |
| S03A | 455.40 | 409.86 | | | 70.80 | 14.16 | | | 424.02 | 526.20 | 0.81 | |
| S03B | 548.60 | 493.74 | | | | | | | 493.74 | 548.60 | 0.90 | |
| S04 - Uncontrolled | 848.00 | 763.20 | | | 1518.00 | 303.60 | | | 1066.80 | 2366.00 | 0.45 | |
| Totals | | | | | | | | | 7357.76 | 11224.80 | 0.66 | |

Notes

- 1) Cavg derived with area calculated from CAD.

S01A and S01B appear to be gravel as per the landscape plan. Please ensure all calculations and plans match accordingly.

TABLE C5: SUMMARY OF POST-DEVELOPMENT PEAK FLOWS (Uncontrolled and Controlled)

| Area No | Area (ha) | Time of Conc, Tc (min) | Storm = 2 yr | | | | | | Storm = 100 yr | | | | | |
|--------------------|--------------|------------------------|------------------|------------------------|---------------|-------------------------|------------------|--------------------------|----------------|--------------------------|------|---------------|---------------|---------|
| | | | C _{AVG} | I ₂ (mm/hr) | Q (L/sec) | Q _{AP} (L/sec) | C _{AVG} | I ₁₀₀ (mm/hr) | Q (L/sec) | Q _{CAP} (L/sec) | | | | |
| S01-A | 0.156 | 10 | 0.34 | 76.81 | 11.27 | (1.38) | 0.34 | 104.19 | 15.28 | (1.87) | 0.42 | 178.56 | 32.74 | (4.00) |
| S01-B | 0.139 | 10 | 0.35 | 76.81 | 10.51 | (1.38) | 0.35 | 104.19 | 14.26 | (1.87) | 0.44 | 178.56 | 30.55 | (4.00) |
| S02 - BLDG | 0.484 | 10 | 0.90 | 76.81 | 92.95 | (14.57) | 0.90 | 104.19 | 126.10 | (19.77) | 1.00 | 178.56 | 240.11 | (37.64) |
| S03A | 0.053 | 10 | 0.81 | 76.81 | 9.05 | (2.08) | 0.81 | 104.19 | 12.28 | (2.82) | 1.00 | 178.56 | 26.12 | (6.00) |
| S03B | 0.055 | 10 | 0.90 | 76.81 | 10.54 | (0.77) | 0.90 | 104.19 | 14.30 | (1.05) | 1.00 | 178.56 | 27.23 | (2.00) |
| S04 - Uncontrolled | 0.237 | 10 | 0.45 | 76.81 | 22.78 | (22.78) | 0.45 | 104.19 | 30.90 | (30.90) | 0.56 | 178.56 | 66.19 | (66.19) |
| TOTAL | 1.122 | | | | 157.10 | 42.96 | | 213.12 | 58.27 | | | 422.94 | 119.83 | |

PDC Response: Agreed. Runoff coefficients for S01A and S01B should be higher to reflect gravel parking lot.

Allowable rates for comparison

119.835

119.835

119.835

Notes

- Intensity, $I = 732.951 / (Tc + 6.199)^{0.810}$ (2-year, City of Ottawa)
- Intensity, $I = 998.071 / (Tc + 6.053)^{0.814}$ (5-year, City of Ottawa)
- Intensity, $I = 1735.688 / (Tc + 6.014)^{0.820}$ (100-year, City of Ottawa)
- Cavg for 100-year is increased by 25% to a maximum of 1.0
- Time of Concentration, Tc = **10 mins**
- For Flows under column Qcap which are shown in brackets (0.0), denotes flows that are controlled

The civil plans and storage calculations table for S03-B note a release rate of 8 L/s. Please update and ensure all tables/plans match.

TABLE C6: SUMMARY OF POST DEVELOPMENT STORAGE & RELEASE RATES

| Area No. | Area (ha) | Max Release Rate (L/s) | | | ¹ Storage Required (m ³) | | | Storage Provided (m ³) | | | | Control Measure | |
|--------------------|---------------|------------------------|--------------|---------------|---|--------------|--------------|------------------------------------|------|---------------|-----------------|-----------------|---------------|
| | | 2-yr | 5-yr | 100-yr | 2-yr (MRM) | 5-yr (MRM) | 100-yr (MRM) | Surface Ponding | Pipe | Roof | UG Chamber/Tank | | Total |
| S01-A | 0.1560 | 1.38 | 1.87 | 4.00 | 8.3 | 11.1 | 23.5 | 44.00 | | | | 44.00 | ICD |
| S01-B | 0.1387 | 1.38 | 1.87 | 4.00 | 7.5 | 10.0 | 21.3 | 37.10 | | | | 37.10 | ICD |
| S02 - BLDG | 0.4837 | 14.57 | 19.77 | 37.64 | 61.0 | 81.9 | 154.6 | | | 180.00 | | 180.00 | ROOF CONTROLS |
| S03A | 0.0526 | 2.08 | 2.82 | 6.00 | 4.9 | 6.6 | 13.9 | 14.20 | | | | 14.20 | ICD |
| S03B | 0.0549 | 0.77 | 1.05 | 2.00 | 6.2 | 8.3 | 23.5 | 32.00 | | | | 32.00 | ICD |
| S04 - Uncontrolled | 0.2366 | 22.78 | 30.90 | 66.19 | | | | | | | | | |
| Totals | 1.1225 | 42.96 | 58.27 | 119.83 | 87.8 | 117.9 | 236.7 | 127.3 | | 180.00 | | 307.30 | |

Notes

- The storage required is based on the Modified Rational Method (MRM) for the release rates noted.

PDC Response: Agreed. There is an error in the spreadsheet.

Storage Volumes for 2-year, 5-Year and 100-Year Storms (MRM)

Area No: **S01**
 $C_{AVG} = \frac{0.34}{(2\text{-yr})}$
 $C_{AVG} = \frac{0.34}{(5\text{-yr})}$
 $C_{AVG} = \frac{0.42}{(100\text{-yr, Max 1.0})}$
 Time Interval = 5.00 (mins)
 Drainage Area = 0.1560 (hectares)

Actual Release Rate (L/sec) = **4.00**
 Percentage of Actual Rate (City of Ottawa requirement) = **100%** (50% when U/G storage used)
 Release Rate Used for Estimation of 100-year Storage (L/sec) = **4.00**

| Duration (mins) | Release Rate = 1.38 (L/sec) Return Period = 2 (years) IDF Parameters, A = 733.0 , B = 0.810 (I = A/(T _c +C), C = 6.199) | | | | | Release Rate = 1.87 (L/sec) Return Period = 5 (years) IDF Parameters, A = 998.1 , B = 0.814 (I = A/(T _c +C), C = 6.053) | | | | | Release Rate = 4.00 (L/sec) Return Period = 100 (years) IDF Parameters, A = 1735.7 , B = 0.820 (I = A/(T _c +C), C = 6.014) | | | | |
|-----------------|---|-------------------|----------------------|----------------------|---------------------------|---|-------------------|----------------------|----------------------|---------------------------|--|-------------------|----------------------|----------------------|---------------------------|
| | Rainfall Intensity, I (mm/hr) | Peak Flow (L/sec) | Release Rate (L/sec) | Storage Rate (L/sec) | Storage (m ³) | Rainfall Intensity, I (mm/hr) | Peak Flow (L/sec) | Release Rate (L/sec) | Storage Rate (L/sec) | Storage (m ³) | Rainfall Intensity, I (mm/hr) | Peak Flow (L/sec) | Release Rate (L/sec) | Storage Rate (L/sec) | Storage (m ³) |
| 0 | 167.2 | 24.5 | 1.4 | 23.2 | 0.0 | 230.5 | 33.8 | 1.9 | 31.9 | 0.0 | 398.6 | 73.1 | 4.0 | 69.1 | 0.0 |
| 5 | 103.6 | 15.2 | 1.4 | 13.8 | 4.1 | 141.2 | 20.7 | 1.9 | 18.8 | 5.7 | 242.7 | 44.5 | 4.0 | 40.5 | 12.1 |
| 10 | 76.8 | 11.3 | 1.4 | 9.9 | 5.9 | 104.2 | 15.3 | 1.9 | 13.4 | 8.0 | 178.6 | 32.7 | 4.0 | 28.7 | 17.2 |
| 15 | 61.8 | 9.1 | 1.4 | 7.7 | 6.9 | 83.6 | 12.3 | 1.9 | 10.4 | 9.3 | 142.9 | 26.2 | 4.0 | 22.2 | 20.0 |
| 20 | 52.0 | 7.6 | 1.4 | 6.3 | 7.5 | 70.3 | 10.3 | 1.9 | 8.4 | 10.1 | 120.0 | 22.0 | 4.0 | 18.0 | 21.6 |
| 25 | 45.2 | 6.6 | 1.4 | 5.2 | 7.9 | 60.9 | 8.9 | 1.9 | 7.1 | 10.6 | 103.8 | 19.0 | 4.0 | 15.0 | 22.6 |
| 30 | 40.0 | 5.9 | 1.4 | 4.5 | 8.1 | 53.9 | 7.9 | 1.9 | 6.0 | 10.9 | 91.9 | 16.8 | 4.0 | 12.8 | 23.1 |
| 35 | 36.1 | 5.3 | 1.4 | 3.9 | 8.2 | 48.5 | 7.1 | 1.9 | 5.2 | 11.0 | 82.6 | 15.1 | 4.0 | 11.1 | 23.4 |
| 40 | 32.9 | 4.8 | 1.4 | 3.4 | 8.3 | 44.2 | 6.5 | 1.9 | 4.6 | 11.1 | 75.1 | 13.8 | 4.0 | 9.8 | 23.5 |
| 45 | 30.2 | 4.4 | 1.4 | 3.1 | 8.3 | 40.6 | 6.0 | 1.9 | 4.1 | 11.0 | 69.1 | 12.7 | 4.0 | 8.7 | 23.4 |
| 50 | 28.0 | 4.1 | 1.4 | 2.7 | 8.2 | 37.7 | 5.5 | 1.9 | 3.7 | 11.0 | 64.0 | 11.7 | 4.0 | 7.7 | 23.2 |
| 55 | 26.2 | 3.8 | 1.4 | 2.5 | 8.1 | 35.1 | 5.2 | 1.9 | 3.3 | 10.8 | 59.6 | 10.9 | 4.0 | 6.9 | 22.9 |
| 60 | 24.6 | 3.6 | 1.4 | 2.2 | 8.0 | 32.9 | 4.8 | 1.9 | 3.0 | 10.7 | 55.9 | 10.2 | 4.0 | 6.2 | 22.5 |
| 65 | 23.2 | 3.4 | 1.4 | 2.0 | 7.9 | 31.0 | 4.6 | 1.9 | 2.7 | 10.5 | 52.6 | 9.7 | 4.0 | 5.7 | 22.0 |
| 70 | 21.9 | 3.2 | 1.4 | 1.8 | 7.7 | 29.4 | 4.3 | 1.9 | 2.4 | 10.3 | 49.8 | 9.1 | 4.0 | 5.1 | 21.5 |
| 75 | 20.8 | 3.1 | 1.4 | 1.7 | 7.5 | 27.9 | 4.1 | 1.9 | 2.2 | 10.0 | 47.3 | 8.7 | 4.0 | 4.7 | 21.0 |
| 80 | 19.8 | 2.9 | 1.4 | 1.5 | 7.4 | 26.6 | 3.9 | 1.9 | 2.0 | 9.7 | 45.0 | 8.2 | 4.0 | 4.2 | 20.4 |
| 85 | 18.9 | 2.8 | 1.4 | 1.4 | 7.2 | 25.4 | 3.7 | 1.9 | 1.9 | 9.5 | 43.0 | 7.9 | 4.0 | 3.9 | 19.8 |
| 90 | 18.1 | 2.7 | 1.4 | 1.3 | 6.9 | 24.3 | 3.6 | 1.9 | 1.7 | 9.2 | 41.1 | 7.5 | 4.0 | 3.5 | 19.1 |
| 95 | 17.4 | 2.6 | 1.4 | 1.2 | 6.7 | 23.3 | 3.4 | 1.9 | 1.6 | 8.8 | 39.4 | 7.2 | 4.0 | 3.2 | 18.4 |
| 100 | 16.7 | 2.5 | 1.4 | 1.1 | 6.5 | 22.4 | 3.3 | 1.9 | 1.4 | 8.5 | 37.9 | 6.9 | 4.0 | 2.9 | 17.7 |

Max = **8.3** **11.1** **23.5**

- Notes**
- 1) Peak flow is equal to the product of 2.78 x C x I x A
 - 2) Rainfall Intensity, I = A/(T_c+C)^B
 - 3) Release Rate = Min (Release Rate, Peak Flow)
 - 4) Storage Rate = Peak Flow - Release Rate
 - 5) Storage = Duration x Storage Rate
 - 6) Maximum Storage = Max Storage Over Duration
 - 7) Parameters a,b,c are for City of Ottawa

IDF curve equations (Intensity in mm/hr)

100 year Intensity = 1735.688 / (Time in min + 6.014)^{0.820}
 50 year Intensity = 1569.580 / (Time in min + 6.014)^{0.820}
 25 year Intensity = 1402.884 / (Time in min + 6.018)^{0.819}
 10 year Intensity = 1174.184 / (Time in min + 6.014)^{0.816}
 5 year Intensity = 998.071 / (Time in min + 6.053)^{0.814}
 2 year Intensity = 732.951 / (Time in min + 6.199)^{0.810}

Storage Volumes for 2-year, 5-Year and 100-Year Storms (MRM)

Area No: S01-B
 $C_{AVG} = \frac{0.35}{(2\text{-yr})}$
 $C_{AVG} = \frac{0.35}{(5\text{-yr})}$
 $C_{AVG} = \frac{0.44}{(100\text{-yr, Max 1.0})}$
 Time Interval = $\frac{5.00}{(mins)}$
 Drainage Area = $\frac{0.1387}{(hectares)}$

Actual Release Rate (L/sec) = **4.00**
 Percentage of Actual Rate (City of Ottawa requirement) = **100%** (Set to 50% when U/G storage used)
 Release Rate Used for Estimation of 100-year Storage (L/sec) = **4.00**

| Duration (mins) | Release Rate = 1.38 (L/sec) Return Period = 2 (years) IDF Parameters, A = 733.0 , B = 0.810 (I = A/(T _c +C), C = 6.199) | | | | | Release Rate = 1.87 (L/sec) Return Period = 5 (years) IDF Parameters, A = 998.1 , B = 0.814 (I = A/(T _c +C), C = 6.053) | | | | | Release Rate = 4.00 (L/sec) Return Period = 100 (years) IDF Parameters, A = 1735.7 , B = 0.820 (I = A/(T _c +C), C = 6.014) | | | | |
|-----------------|---|-------------------|----------------------|----------------------|---------------------------|---|-------------------|----------------------|----------------------|---------------------------|--|-------------------|----------------------|----------------------|---------------------------|
| | Rainfall Intensity, I (mm/hr) | Peak Flow (L/sec) | Release Rate (L/sec) | Storage Rate (L/sec) | Storage (m ³) | Rainfall Intensity, I (mm/hr) | Peak Flow (L/sec) | Release Rate (L/sec) | Storage Rate (L/sec) | Storage (m ³) | Rainfall Intensity, I (mm/hr) | Peak Flow (L/sec) | Release Rate (L/sec) | Storage Rate (L/sec) | Storage (m ³) |
| 0 | 167.2 | 22.9 | 1.4 | 21.5 | 0.0 | 230.5 | 31.5 | 1.9 | 29.7 | 0.0 | 398.6 | 68.2 | 4.0 | 64.2 | 0.0 |
| 5 | 103.6 | 14.2 | 1.4 | 12.8 | 3.8 | 141.2 | 19.3 | 1.9 | 17.5 | 5.2 | 242.7 | 41.5 | 4.0 | 37.5 | 11.3 |
| 10 | 76.8 | 10.5 | 1.4 | 9.1 | 5.5 | 104.2 | 14.3 | 1.9 | 12.4 | 7.4 | 178.6 | 30.5 | 4.0 | 26.5 | 15.9 |
| 15 | 61.8 | 8.5 | 1.4 | 7.1 | 6.4 | 83.6 | 11.4 | 1.9 | 9.6 | 8.6 | 142.9 | 24.4 | 4.0 | 20.4 | 18.4 |
| 20 | 52.0 | 7.1 | 1.4 | 5.7 | 6.9 | 70.3 | 9.6 | 1.9 | 7.7 | 9.3 | 120.0 | 20.5 | 4.0 | 16.5 | 19.8 |
| 25 | 45.2 | 6.2 | 1.4 | 4.8 | 7.2 | 60.9 | 8.3 | 1.9 | 6.5 | 9.7 | 103.8 | 17.8 | 4.0 | 13.8 | 20.6 |
| 30 | 40.0 | 5.5 | 1.4 | 4.1 | 7.4 | 53.9 | 7.4 | 1.9 | 5.5 | 9.9 | 91.9 | 15.7 | 4.0 | 11.7 | 21.1 |
| 35 | 36.1 | 4.9 | 1.4 | 3.6 | 7.5 | 48.5 | 6.6 | 1.9 | 4.8 | 10.0 | 82.6 | 14.1 | 4.0 | 10.1 | 21.3 |
| 40 | 32.9 | 4.5 | 1.4 | 3.1 | 7.5 | 44.2 | 6.0 | 1.9 | 4.2 | 10.0 | 75.1 | 12.9 | 4.0 | 8.9 | 21.3 |
| 45 | 30.2 | 4.1 | 1.4 | 2.8 | 7.5 | 40.6 | 5.6 | 1.9 | 3.7 | 10.0 | 69.1 | 11.8 | 4.0 | 7.8 | 21.1 |
| 50 | 28.0 | 3.8 | 1.4 | 2.5 | 7.4 | 37.7 | 5.2 | 1.9 | 3.3 | 9.9 | 64.0 | 10.9 | 4.0 | 6.9 | 20.8 |
| 55 | 26.2 | 3.6 | 1.4 | 2.2 | 7.3 | 35.1 | 4.8 | 1.9 | 2.9 | 9.7 | 59.6 | 10.2 | 4.0 | 6.2 | 20.5 |
| 60 | 24.6 | 3.4 | 1.4 | 2.0 | 7.1 | 32.9 | 4.5 | 1.9 | 2.6 | 9.5 | 55.9 | 9.6 | 4.0 | 5.6 | 20.0 |
| 65 | 23.2 | 3.2 | 1.4 | 1.8 | 7.0 | 31.0 | 4.2 | 1.9 | 2.4 | 9.3 | 52.6 | 9.0 | 4.0 | 5.0 | 19.5 |
| 70 | 21.9 | 3.0 | 1.4 | 1.6 | 6.8 | 29.4 | 4.0 | 1.9 | 2.2 | 9.0 | 49.8 | 8.5 | 4.0 | 4.5 | 19.0 |
| 75 | 20.8 | 2.8 | 1.4 | 1.5 | 6.6 | 27.9 | 3.8 | 1.9 | 1.9 | 8.8 | 47.3 | 8.1 | 4.0 | 4.1 | 18.4 |
| 80 | 19.8 | 2.7 | 1.4 | 1.3 | 6.4 | 26.6 | 3.6 | 1.9 | 1.8 | 8.5 | 45.0 | 7.7 | 4.0 | 3.7 | 17.7 |
| 85 | 18.9 | 2.6 | 1.4 | 1.2 | 6.2 | 25.4 | 3.5 | 1.9 | 1.6 | 8.2 | 43.0 | 7.3 | 4.0 | 3.3 | 17.1 |
| 90 | 18.1 | 2.5 | 1.4 | 1.1 | 6.0 | 24.3 | 3.3 | 1.9 | 1.5 | 7.9 | 41.1 | 7.0 | 4.0 | 3.0 | 16.4 |
| 95 | 17.4 | 2.4 | 1.4 | 1.0 | 5.7 | 23.3 | 3.2 | 1.9 | 1.3 | 7.5 | 39.4 | 6.7 | 4.0 | 2.7 | 15.7 |
| 100 | 16.7 | 2.3 | 1.4 | 0.9 | 5.5 | 22.4 | 3.1 | 1.9 | 1.2 | 7.2 | 37.9 | 6.5 | 4.0 | 2.5 | 14.9 |
| Max = | | | | | 7.5 | | | | | 10.0 | | | | | 21.3 |

Notes

- 1) Peak flow is equal to the product of 2.78 x C x I x A
- 2) Rainfall Intensity, I = A/(T_c+C)^B
- 3) Release Rate = Min (Release Rate, Peak Flow)
- 4) Storage Rate = Peak Flow - Release Rate
- 5) Storage = Duration x Storage Rate
- 6) Maximum Storage = Max Storage Over Duration
- 7) Parameters a,b,c are for City of Ottawa

IDF curve equations (Intensity in mm/hr)

100 year Intensity = 1735.688 / (Time in min + 6.014)^{0.820}
 50 year Intensity = 1569.580 / (Time in min + 6.014)^{0.820}
 25 year Intensity = 1402.884 / (Time in min + 6.018)^{0.819}
 10 year Intensity = 1174.184 / (Time in min + 6.014)^{0.816}
 5 year Intensity = 998.071 / (Time in min + 6.053)^{0.814}
 2 year Intensity = 732.951 / (Time in min + 6.199)^{0.810}

Storage Volumes for 2-year, 5-Year and 100-Year Storms (MRM)

Area No: **S02 ROOF CONTROL**

$C_{AVG} = \frac{0.90}{(2\text{-yr})}$
 $C_{AVG} = \frac{0.90}{(5\text{-yr})}$
 $C_{AVG} = \frac{1.00}{(100\text{-yr, Max 1.0})}$

Time Interval = $\frac{10.00}{(mins)}$
 Drainage Area = $\frac{0.4837}{(hectares)}$
 0.072555

Actual Release Rate (L/sec) = **35.64**
 Percentage of Actual Rate (City of Ottawa requirement) = **100%** (50% when U/G storage used)
 Release Rate Used for Estimation of 100-year Storage (L/sec) = **35.64**

| Duration (mins) | Release Rate = 13.80 (L/sec) Return Period = 2 (years) IDF Parameters, A = 733.0 , B = 0.810 (I = A/(T _c +C), C = 6.199) | | | | | Release Rate = 18.72 (L/sec) Return Period = 5 (years) IDF Parameters, A = 998.1 , B = 0.814 (I = A/(T _c +C), C = 6.053) | | | | | Release Rate = 35.64 (L/sec) Return Period = 100 (years) IDF Parameters, A = 1735.7 , B = 0.820 (I = A/(T _c +C), C = 6.014) | | | | |
|-----------------|--|-------------------|----------------------|----------------------|---------------------------|--|-------------------|----------------------|----------------------|---------------------------|---|-------------------|----------------------|----------------------|---------------------------|
| | Rainfall Intensity, I (mm/hr) | Peak Flow (L/sec) | Release Rate (L/sec) | Storage Rate (L/sec) | Storage (m ³) | Rainfall Intensity, I (mm/hr) | Peak Flow (L/sec) | Release Rate (L/sec) | Storage Rate (L/sec) | Storage (m ³) | Rainfall Intensity, I (mm/hr) | Peak Flow (L/sec) | Release Rate (L/sec) | Storage Rate (L/sec) | Storage (m ³) |
| 10 | 76.8 | 93.0 | 13.8 | 79.2 | 47.5 | 104.2 | 126.1 | 18.7 | 107.4 | 64.4 | 178.6 | 240.1 | 35.6 | 204.5 | 122.7 |
| 20 | 52.0 | 63.0 | 13.8 | 49.2 | 59.0 | 70.3 | 85.0 | 18.7 | 66.3 | 79.6 | 120.0 | 161.3 | 35.6 | 125.7 | 150.8 |
| 30 | 40.0 | 48.5 | 13.8 | 34.7 | 62.4 | 53.9 | 65.3 | 18.7 | 46.5 | 83.8 | 91.9 | 123.5 | 35.6 | 87.9 | 158.2 |
| 40 | 32.9 | 39.8 | 13.8 | 26.0 | 62.3 | 44.2 | 53.5 | 18.7 | 34.8 | 83.4 | 75.1 | 101.0 | 35.6 | 65.4 | 157.0 |
| 50 | 28.0 | 33.9 | 13.8 | 20.1 | 60.4 | 37.7 | 45.6 | 18.7 | 26.9 | 80.6 | 64.0 | 86.0 | 35.6 | 50.4 | 151.1 |
| 60 | 24.6 | 29.7 | 13.8 | 15.9 | 57.3 | 32.9 | 39.9 | 18.7 | 21.2 | 76.1 | 55.9 | 75.2 | 35.6 | 39.5 | 142.3 |
| 70 | 21.9 | 26.5 | 13.8 | 12.7 | 53.4 | 29.4 | 35.5 | 18.7 | 16.8 | 70.7 | 49.8 | 67.0 | 35.6 | 31.3 | 131.5 |
| 80 | 19.8 | 24.0 | 13.8 | 10.2 | 49.0 | 26.6 | 32.1 | 18.7 | 13.4 | 64.5 | 45.0 | 60.5 | 35.6 | 24.9 | 119.3 |
| 90 | 18.1 | 22.0 | 13.8 | 8.2 | 44.1 | 24.3 | 29.4 | 18.7 | 10.7 | 57.7 | 41.1 | 55.3 | 35.6 | 19.6 | 106.1 |
| 100 | 16.7 | 20.3 | 13.8 | 6.5 | 38.8 | 22.4 | 27.1 | 18.7 | 8.4 | 50.4 | 37.9 | 51.0 | 35.6 | 15.3 | 92.0 |
| 110 | 15.6 | 18.8 | 13.8 | 5.0 | 33.3 | 20.8 | 25.2 | 18.7 | 6.5 | 42.8 | 35.2 | 47.3 | 35.6 | 11.7 | 77.2 |
| 120 | 14.6 | 17.6 | 13.8 | 3.8 | 27.5 | 19.5 | 23.6 | 18.7 | 4.8 | 34.9 | 32.9 | 44.2 | 35.6 | 8.6 | 61.9 |
| 130 | 13.7 | 16.6 | 13.8 | 2.8 | 21.6 | 18.3 | 22.1 | 18.7 | 3.4 | 26.7 | 30.9 | 41.5 | 35.6 | 5.9 | 46.1 |
| 140 | 12.9 | 15.6 | 13.8 | 1.8 | 15.5 | 17.3 | 20.9 | 18.7 | 2.2 | 18.3 | 29.2 | 39.2 | 35.6 | 3.6 | 29.9 |
| 150 | 12.3 | 14.8 | 13.8 | 1.0 | 9.3 | 16.4 | 19.8 | 18.7 | 1.1 | 9.8 | 27.6 | 37.1 | 35.6 | 1.5 | 13.4 |
| 160 | 11.7 | 14.1 | 13.8 | 0.3 | 2.9 | 15.6 | 18.8 | 18.7 | 0.1 | 1.0 | 26.2 | 35.3 | 35.6 | -0.4 | -3.4 |
| 170 | 11.1 | 13.4 | 13.8 | -0.3 | -3.6 | 14.8 | 18.0 | 18.7 | -0.8 | -7.8 | 25.0 | 33.6 | 35.6 | -2.0 | -20.5 |
| 180 | 10.6 | 12.9 | 13.8 | -0.9 | -10.1 | 14.2 | 17.2 | 18.7 | -1.6 | -16.8 | 23.9 | 32.1 | 35.6 | -3.5 | -37.8 |
| 190 | 10.2 | 12.3 | 13.8 | -1.5 | -16.8 | 13.6 | 16.4 | 18.7 | -2.3 | -25.9 | 22.9 | 30.8 | 35.6 | -4.9 | -55.3 |
| 200 | 9.8 | 11.8 | 13.8 | -2.0 | -23.5 | 13.0 | 15.8 | 18.7 | -2.9 | -35.1 | 22.0 | 29.6 | 35.6 | -6.1 | -73.0 |
| 210 | 9.4 | 11.4 | 13.8 | -2.4 | -30.3 | 12.6 | 15.2 | 18.7 | -3.5 | -44.4 | 21.1 | 28.4 | 35.6 | -7.2 | -90.8 |

Max = **62.4** **83.8** **158.2**

- Notes**
- 1) Peak flow is equal to the product of 2.78 x C x I x A
 - 2) Rainfall Intensity, I = A/(T_c+C)^B
 - 3) Release Rate = Min (Release Rate, Peak Flow)
 - 4) Storage Rate = Peak Flow - Release Rate
 - 5) Storage = Duration x Storage Rate
 - 6) Maximum Storage = Max Storage Over Duration
 - 7) Parameters a,b,c are for City of Ottawa



$$V = (I * w) * h / 3 = Ah / 3$$

ROOFTOP AVAILABLE VOLUME:
 A_{TOT} = 4500 m²
 A_{EFF} = 4500 * 0.8 = 3600 m²
Trapezoidal Volume
 V = A x h x 1/3
 V = 3600 x 0.15 x 1/3
V = 180 m³

IDF curve equations (Intensity in mm/hr)

100 year Intensity = 1735.688 / (Time in min + 6.014)^{0.820}
 50 year Intensity = 1569.580 / (Time in min + 6.014)^{0.820}
 25 year Intensity = 1402.884 / (Time in min + 6.018)^{0.819}
 10 year Intensity = 1174.184 / (Time in min + 6.014)^{0.816}
 5 year Intensity = 998.071 / (Time in min + 6.053)^{0.814}
 2 year Intensity = 732.951 / (Time in min + 6.199)^{0.810}

Storage Volumes for 2-year, 5-Year and 100-Year Storms (MRM)

Area No: **S03A**

$C_{AVG} = \frac{0.81}{(2\text{-yr})}$

$C_{AVG} = \frac{0.81}{(5\text{-yr})}$

$C_{AVG} = \frac{1.00}{(100\text{-yr, Max 1.0})}$

Time Interval = 5.00 (mins)

Drainage Area = 0.0526 (hectares)

Actual Release Rate (L/sec) = **8.00**

Percentage of Actual Rate (City of Ottawa requirement) = **100%** (50% when U/G storage used)

Release Rate Used for Estimation of 100-year Storage (L/sec) = **8.00**

| Duration (mins) | Release Rate = 2.77 (L/sec) Return Period = 2 (years) IDF Parameters, A = 733.0 , B = 0.810 (I = A/(T _c +C), C = 6.199) | | | | | Release Rate = 3.76 (L/sec) Return Period = 5 (years) IDF Parameters, A = 998.1 , B = 0.814 (I = A/(T _c +C), C = 6.053) | | | | | Release Rate = 8.00 (L/sec) Return Period = 100 (years) IDF Parameters, A = 1735.7 , B = 0.820 (I = A/(T _c +C), C = 6.014) | | | | |
|-----------------|---|-------------------|----------------------|----------------------|---------------------------|---|-------------------|----------------------|----------------------|---------------------------|--|-------------------|----------------------|----------------------|---------------------------|
| | Rainfall Intensity, I (mm/hr) | Peak Flow (L/sec) | Release Rate (L/sec) | Storage Rate (L/sec) | Storage (m ³) | Rainfall Intensity, I (mm/hr) | Peak Flow (L/sec) | Release Rate (L/sec) | Storage Rate (L/sec) | Storage (m ³) | Rainfall Intensity, I (mm/hr) | Peak Flow (L/sec) | Release Rate (L/sec) | Storage Rate (L/sec) | Storage (m ³) |
| 10 | 76.8 | 9.1 | 2.8 | 6.3 | 3.8 | 104.2 | 12.3 | 3.8 | 8.5 | 5.1 | 178.6 | 26.1 | 8.0 | 18.1 | 10.9 |
| 15 | 61.8 | 7.3 | 2.8 | 4.5 | 4.1 | 83.6 | 9.8 | 3.8 | 6.1 | 5.5 | 142.9 | 20.9 | 8.0 | 12.9 | 11.6 |
| 20 | 52.0 | 6.1 | 2.8 | 3.4 | 4.0 | 70.3 | 8.3 | 3.8 | 4.5 | 5.4 | 120.0 | 17.5 | 8.0 | 9.5 | 11.5 |
| 25 | 45.2 | 5.3 | 2.8 | 2.6 | 3.8 | 60.9 | 7.2 | 3.8 | 3.4 | 5.1 | 103.8 | 15.2 | 8.0 | 7.2 | 10.8 |
| 30 | 40.0 | 4.7 | 2.8 | 1.9 | 3.5 | 53.9 | 6.4 | 3.8 | 2.6 | 4.7 | 91.9 | 13.4 | 8.0 | 5.4 | 9.8 |
| 35 | 36.1 | 4.3 | 2.8 | 1.5 | 3.1 | 48.5 | 5.7 | 3.8 | 2.0 | 4.1 | 82.6 | 12.1 | 8.0 | 4.1 | 8.6 |
| 40 | 32.9 | 3.9 | 2.8 | 1.1 | 2.6 | 44.2 | 5.2 | 3.8 | 1.4 | 3.5 | 75.1 | 11.0 | 8.0 | 3.0 | 7.2 |
| 45 | 30.2 | 3.6 | 2.8 | 0.8 | 2.1 | 40.6 | 4.8 | 3.8 | 1.0 | 2.8 | 69.1 | 10.1 | 8.0 | 2.1 | 5.7 |
| 50 | 28.0 | 3.3 | 2.8 | 0.5 | 1.6 | 37.7 | 4.4 | 3.8 | 0.7 | 2.0 | 64.0 | 9.4 | 8.0 | 1.4 | 4.1 |
| 55 | 26.2 | 3.1 | 2.8 | 0.3 | 1.0 | 35.1 | 4.1 | 3.8 | 0.4 | 1.2 | 59.6 | 8.7 | 8.0 | 0.7 | 2.4 |
| 60 | 24.6 | 2.9 | 2.8 | 0.1 | 0.4 | 32.9 | 3.9 | 3.8 | 0.1 | 0.4 | 55.9 | 8.2 | 8.0 | 0.2 | 0.6 |
| 65 | 23.2 | 2.7 | 2.8 | 0.0 | -0.2 | 31.0 | 3.7 | 3.8 | -0.1 | -0.4 | 52.6 | 7.7 | 8.0 | -0.3 | -1.2 |
| 70 | 21.9 | 2.6 | 2.8 | -0.2 | -0.8 | 29.4 | 3.5 | 3.8 | -0.3 | -1.3 | 49.8 | 7.3 | 8.0 | -0.7 | -3.0 |
| 75 | 20.8 | 2.5 | 2.8 | -0.3 | -1.4 | 27.9 | 3.3 | 3.8 | -0.5 | -2.1 | 47.3 | 6.9 | 8.0 | -1.1 | -4.9 |
| 80 | 19.8 | 2.3 | 2.8 | -0.4 | -2.1 | 26.6 | 3.1 | 3.8 | -0.6 | -3.0 | 45.0 | 6.6 | 8.0 | -1.4 | -6.8 |
| 85 | 18.9 | 2.2 | 2.8 | -0.5 | -2.8 | 25.4 | 3.0 | 3.8 | -0.8 | -3.9 | 43.0 | 6.3 | 8.0 | -1.7 | -8.8 |
| 90 | 18.1 | 2.1 | 2.8 | -0.6 | -3.4 | 24.3 | 2.9 | 3.8 | -0.9 | -4.9 | 41.1 | 6.0 | 8.0 | -2.0 | -10.7 |
| 95 | 17.4 | 2.1 | 2.8 | -0.7 | -4.1 | 23.3 | 2.7 | 3.8 | -1.0 | -5.8 | 39.4 | 5.8 | 8.0 | -2.2 | -12.7 |
| 100 | 16.7 | 2.0 | 2.8 | -0.8 | -4.8 | 22.4 | 2.6 | 3.8 | -1.1 | -6.7 | 37.9 | 5.5 | 8.0 | -2.5 | -14.7 |
| 105 | 16.1 | 1.9 | 2.8 | -0.9 | -5.5 | 21.6 | 2.5 | 3.8 | -1.2 | -7.7 | 36.5 | 5.3 | 8.0 | -2.7 | -16.8 |
| 110 | 15.6 | 1.8 | 2.8 | -0.9 | -6.2 | 20.8 | 2.5 | 3.8 | -1.3 | -8.6 | 35.2 | 5.1 | 8.0 | -2.9 | -18.8 |

Max = **4.1** **5.5** **11.6**

Notes

- 1) Peak flow is equal to the product of 2.78 x C x I x A
- 2) Rainfall Intensity, I = A/(T_c+C)^B
- 3) Release Rate = Min (Release Rate, Peak Flow)
- 4) Storage Rate = Peak Flow - Release Rate
- 5) Storage = Duration x Storage Rate
- 6) Maximum Storage = Max Storage Over Duration
- 7) Parameters a,b,c are for City of Ottawa

IDF curve equations (Intensity in mm/hr)

100 year Intensity = 1735.688 / (Time in min + 6.014)^{0.820}

50 year Intensity = 1569.580 / (Time in min + 6.014)^{0.820}

25 year Intensity = 1402.884 / (Time in min + 6.018)^{0.819}

10 year Intensity = 1174.184 / (Time in min + 6.014)^{0.816}

5 year Intensity = 998.071 / (Time in min + 6.053)^{0.814}

2 year Intensity = 732.951 / (Time in min + 6.199)^{0.810}

Storage Volumes for 2-year, 5-Year and 100-Year Storms (MRM)

Area No: **S03B**

$C_{AVG} = 0.90$ (2-yr)

$C_{AVG} = 0.90$ (5-yr)

$C_{AVG} = 1.00$ (100-yr, Max 1.0)

Time Interval = 5.00 (mins)

Drainage Area = 0.0549 (hectares)

Actual Release Rate (L/sec) = **2.00**

Percentage of Actual Rate (City of Ottawa requirement) = **100%** (50% when U/G storage used)

Release Rate Used for Estimation of 100-year Storage (L/sec) = **2.00**

Please clarify why the release rate is lower than the 2/5 year events when the head is higher.

| Duration (mins) | Release Rate = 2.08 (L/sec) Return Period = 2 (years) IDF Parameters, A = 733.0 , B = 0.810 (I = A/(T _c +C), C = 6.199) | | | | | Release Rate = 2.82 (L/sec) Return Period = 5 (years) IDF Parameters, A = 998.1 , B = 0.814 (I = A/(T _c +C), C = 6.053) | | | | | Release Rate = 2.00 (L/sec) Return Period = 100 (years) IDF Parameters, A = 1735.7 , B = 0.810 (I = A/(T _c +C), C = 6.053) | | | | |
|-----------------|---|-------------------|----------------------|----------------------|---------------------------|---|-------------------|----------------------|----------------------|---------------------------|--|-------------------|----------------------|----------------------|---------------------------|
| | Rainfall Intensity, I (mm/hr) | Peak Flow (L/sec) | Release Rate (L/sec) | Storage Rate (L/sec) | Storage (m ³) | Rainfall Intensity, I (mm/hr) | Peak Flow (L/sec) | Release Rate (L/sec) | Storage Rate (L/sec) | Storage (m ³) | Rainfall Intensity, I (mm/hr) | Peak Flow (L/sec) | Release Rate (L/sec) | Storage Rate (L/sec) | Storage (m ³) |
| 10 | 76.8 | 10.5 | 2.1 | 8.5 | 5.1 | 104.2 | 14.3 | 2.8 | 11.5 | 6.9 | 178.6 | 27.2 | 2.0 | 25.2 | 15.1 |
| 15 | 61.8 | 8.5 | 2.1 | 6.4 | 5.8 | 83.6 | 11.5 | 2.8 | 8.6 | 7.8 | 142.9 | 21.8 | 2.0 | 19.8 | 17.8 |
| 20 | 52.0 | 7.1 | 2.1 | 5.1 | 6.1 | 70.3 | 9.6 | 2.8 | 6.8 | 8.2 | 120.0 | 18.3 | 2.0 | 16.3 | 19.6 |
| 25 | 45.2 | 6.2 | 2.1 | 4.1 | 6.2 | 60.9 | 8.4 | 2.8 | 5.5 | 8.3 | 103.8 | 15.8 | 2.0 | 13.8 | 20.8 |
| 30 | 40.0 | 5.5 | 2.1 | 3.4 | 6.2 | 53.9 | 7.4 | 2.8 | 4.6 | 8.2 | 91.9 | 14.0 | 2.0 | 12.0 | 21.6 |
| 35 | 36.1 | 4.9 | 2.1 | 2.9 | 6.0 | 48.5 | 6.7 | 2.8 | 3.8 | 8.1 | 82.6 | 12.6 | 2.0 | 10.6 | 22.2 |
| 40 | 32.9 | 4.5 | 2.1 | 2.4 | 5.8 | 44.2 | 6.1 | 2.8 | 3.2 | 7.8 | 75.1 | 11.5 | 2.0 | 9.5 | 22.7 |
| 45 | 30.2 | 4.2 | 2.1 | 2.1 | 5.6 | 40.6 | 5.6 | 2.8 | 2.8 | 7.4 | 69.1 | 10.5 | 2.0 | 8.5 | 23.0 |
| 50 | 28.0 | 3.8 | 2.1 | 1.8 | 5.3 | 37.7 | 5.2 | 2.8 | 2.3 | 7.0 | 64.0 | 9.8 | 2.0 | 7.8 | 23.3 |
| 55 | 26.2 | 3.6 | 2.1 | 1.5 | 5.0 | 35.1 | 4.8 | 2.8 | 2.0 | 6.6 | 59.6 | 9.1 | 2.0 | 7.1 | 23.4 |
| 60 | 24.6 | 3.4 | 2.1 | 1.3 | 4.6 | 32.9 | 4.5 | 2.8 | 1.7 | 6.1 | 55.9 | 8.5 | 2.0 | 6.5 | 23.5 |
| 65 | 23.2 | 3.2 | 2.1 | 1.1 | 4.3 | 31.0 | 4.3 | 2.8 | 1.4 | 5.6 | 52.6 | 8.0 | 2.0 | 6.0 | 23.5 |
| 70 | 21.9 | 3.0 | 2.1 | 0.9 | 3.9 | 29.4 | 4.0 | 2.8 | 1.2 | 5.1 | 49.8 | 7.6 | 2.0 | 5.6 | 23.5 |
| 75 | 20.8 | 2.9 | 2.1 | 0.8 | 3.5 | 27.9 | 3.8 | 2.8 | 1.0 | 4.5 | 47.3 | 7.2 | 2.0 | 5.2 | 23.4 |
| 80 | 19.8 | 2.7 | 2.1 | 0.6 | 3.1 | 26.6 | 3.6 | 2.8 | 0.8 | 4.0 | 45.0 | 6.9 | 2.0 | 4.9 | 23.3 |
| 85 | 18.9 | 2.6 | 2.1 | 0.5 | 2.7 | 25.4 | 3.5 | 2.8 | 0.7 | 3.4 | 43.0 | 6.6 | 2.0 | 4.6 | 23.2 |
| 90 | 18.1 | 2.5 | 2.1 | 0.4 | 2.2 | 24.3 | 3.3 | 2.8 | 0.5 | 2.8 | 41.1 | 6.3 | 2.0 | 4.3 | 23.1 |
| 95 | 17.4 | 2.4 | 2.1 | 0.3 | 1.8 | 23.3 | 3.2 | 2.8 | 0.4 | 2.2 | 39.4 | 6.0 | 2.0 | 4.0 | 22.9 |
| 100 | 16.7 | 2.3 | 2.1 | 0.2 | 1.3 | 22.4 | 3.1 | 2.8 | 0.3 | 1.5 | 37.9 | 5.8 | 2.0 | 3.8 | 22.7 |
| 105 | 16.1 | 2.2 | 2.1 | 0.1 | 0.8 | 21.6 | 3.0 | 2.8 | 0.1 | 0.9 | 36.5 | 5.6 | 2.0 | 3.6 | 22.5 |
| 110 | 15.6 | 2.1 | 2.1 | 0.1 | 0.4 | 20.8 | 2.9 | 2.8 | 0.0 | 0.2 | 35.2 | 5.4 | 2.0 | 3.4 | 22.2 |
| Max = | | | | | 6.2 | | | | | 8.3 | | | | | 23.5 |

PDC Response: Agreed. There is an error in the spreadsheet.

- Notes**
- 1) Peak flow is equal to the product of 2.78 x C x I x A
 - 2) Rainfall Intensity, I = A/(T_c+C)^B
 - 3) Release Rate = Min (Release Rate, Peak Flow)
 - 4) Storage Rate = Peak Flow - Release Rate
 - 5) Storage = Duration x Storage Rate
 - 6) Maximum Storage = Max Storage Over Duration
 - 7) Parameters a,b,c are for City of Ottawa

IDF curve equations (Intensity in mm/hr)

100 year Intensity = 1735.688 / (Time in min + 6.014)^{0.820}

50 year Intensity = 1569.580 / (Time in min + 6.014)^{0.820}

25 year Intensity = 1402.884 / (Time in min + 6.018)^{0.819}

10 year Intensity = 1174.184 / (Time in min + 6.014)^{0.816}

5 year Intensity = 998.071 / (Time in min + 6.053)^{0.814}

2 year Intensity = 732.951 / (Time in min + 6.199)^{0.810}

CSO/STORMWATER MANAGEMENT



HYDROVEX[®] VHV / SVHV
Vertical Vortex Flow Regulator

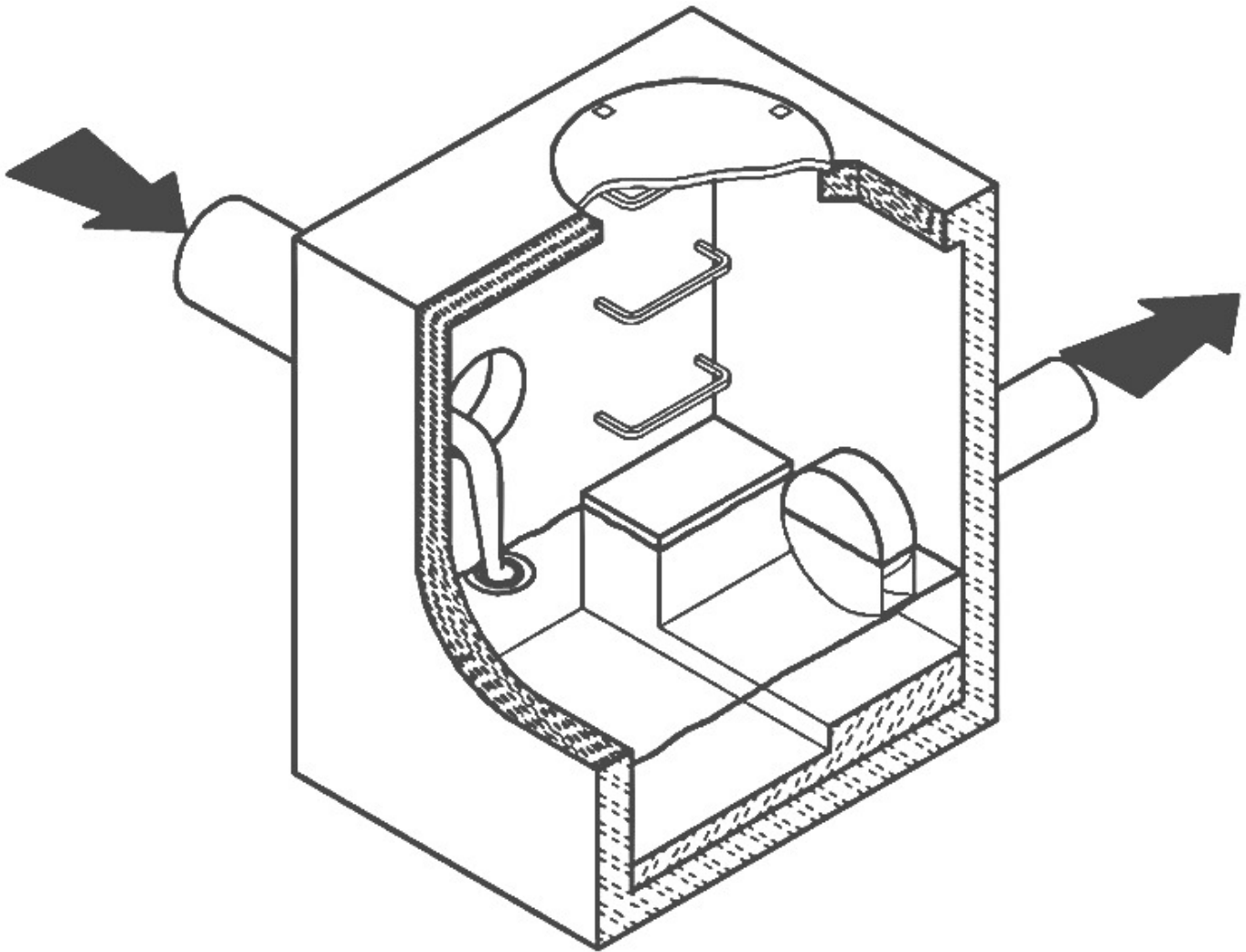

JOHN MEUNIER

HYDROVEX® VHV / SVHV VERTICAL VORTEX FLOW REGULATOR

APPLICATIONS

One of the major problems of urban wet weather flow management is the runoff generated after a heavy rainfall. During a storm, uncontrolled flows may overload the drainage system and cause flooding. Due to increased velocities, sewer pipe wear is increased dramatically and results in network deterioration. In a combined sewer system, the wastewater treatment plant may also experience significant increases in flows during storms, thereby losing its treatment efficiency.

A simple means of controlling excessive water runoff is by controlling excessive flows at their origin (manholes). **John Meunier Inc.** manufactures the **HYDROVEX® VHV / SVHV** line of vortex flow regulators to control stormwater flows in sewer networks, as well as manholes.

The vortex flow regulator design is based on the fluid mechanics principle of the forced vortex. This grants flow regulation without any moving parts, thus reducing maintenance. The operation of the regulator, depending on the upstream head and discharge, switches between orifice flow (gravity flow) and vortex flow. Although the concept is quite simple, over 12 years of research have been carried out in order to get a high performance.

The **HYDROVEX® VHV / SVHV** Vertical Vortex Flow Regulators (refer to **Figure 1**) are manufactured entirely of stainless steel, and consist of a hollow body (1) (in which flow control takes place) and an outlet orifice (7). Two rubber "O" rings (3) seal and retain the unit inside the outlet pipe. Two stainless steel retaining rings (4) are welded on the outlet sleeve to ensure that there is no shifting of the "O" rings during installation and use.

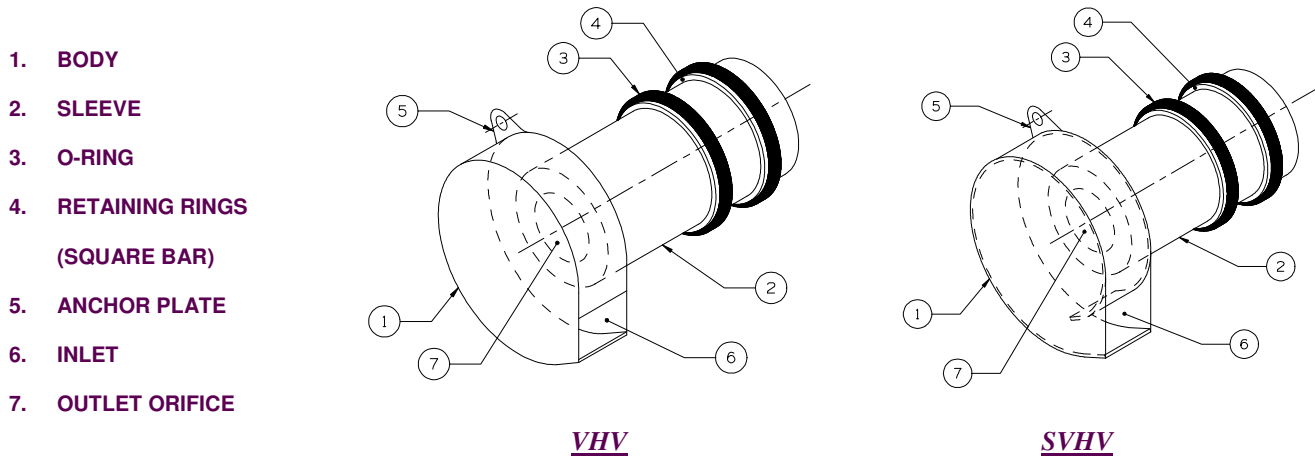

FIGURE 1: HYDROVEX® VHV-SVHV VERTICAL VORTEX FLOW REGULATORS

ADVANTAGES

- The **HYDROVEX® VHV / SVHV** line of flow regulators are manufactured entirely of stainless steel, making them durable and corrosion resistant.
- Having no moving parts, they require minimal maintenance.
- The geometry of the **HYDROVEX® VHV / SVHV** flow regulators allows a control equal to an orifice plate, having a cross section area 4 to 6 times smaller. This decreases the chance of blockage of the regulator, due to sediments and debris found in stormwater flows. **Figure 2** illustrates the comparison between a regulator model 100 SVHV-2 and an equivalent orifice plate. One can see that for the same height of water, the regulator controls a flow approximately four times smaller than an equivalent orifice plate.
- Installation of the **HYDROVEX® VHV / SVHV** flow regulators is quick and straightforward and is performed after all civil works are completed.
- Installation requires no special tools or equipment and may be carried out by any contractor.
- Installation may be carried out in existing structures.

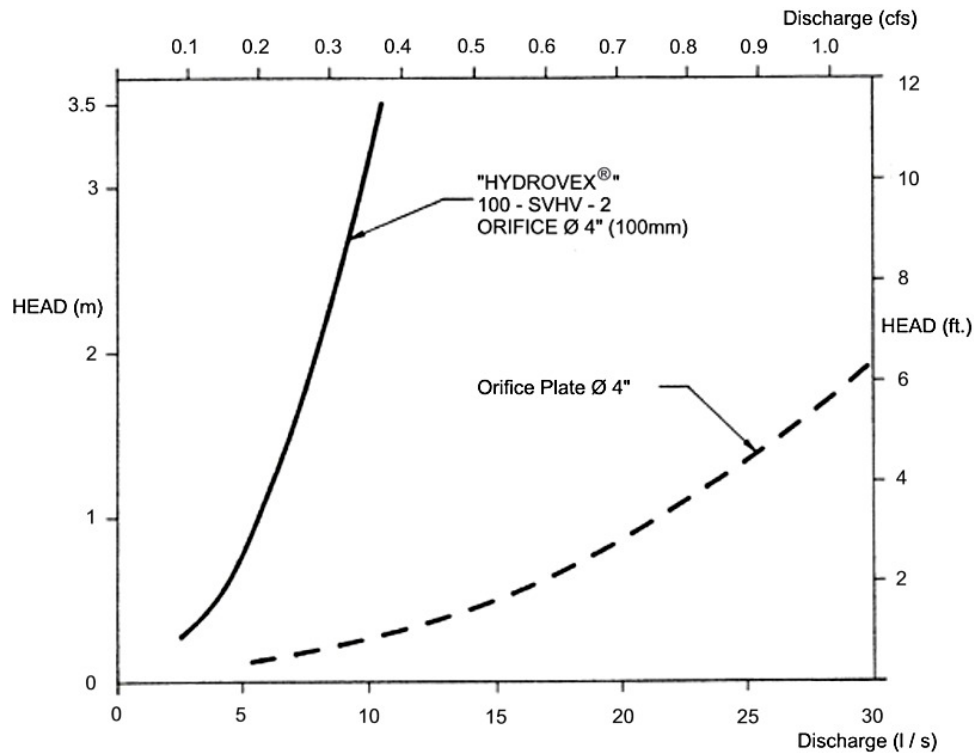

FIGURE 2: DISCHARGE CURVE SHOWING A HYDROVEX® FLOW REGULATOR VS AN ORIFICE PLATE

SELECTION

Selection of a **VHV** or **SVHV** regulator can be easily made using the selection charts found at the back of this brochure (see **Figure 3**). These charts are a graphical representation of the maximum upstream water pressure (head) and the maximum discharge at the manhole outlet. The maximum design head is the difference between the maximum upstream water level and the invert of the outlet pipe. All selections should be verified by John Meunier Inc. personnel prior to fabrication.

Example:

- ✓ Maximum design head 2m (6.56 ft.)
- ✓ Maximum discharge 6 L/s (0.2 cfs)
- ✓ Using **Figure 3** - VHV model required is a **75 VHV-1**

INSTALLATION REQUIREMENTS

All **HYDROVEX®** **VHV** / **SVHV** flow regulators can be installed in circular or square manholes. **Figure 4** gives the various minimum dimensions required for a given regulator. *It is imperative to respect the minimum clearances shown to ensure easy installation and proper functioning of the regulator.*

SPECIFICATIONS

In order to specify a **HYDROVEX**[®] regulator, the following parameters must be defined:

- The model number (ex: 75-VHV-1)
- The diameter and type of outlet pipe (ex: 6" diam. SDR 35)
- The desired discharge (ex: 6 l/s or 0.21 CFS)
- The upstream head (ex: 2 m or 6.56 ft.) *
- The manhole diameter (ex: 36" diam.)
- The minimum clearance "H" (ex: 10 inches)
- The material type (ex: 304 s/s, 11 Ga. standard)

* *Upstream head is defined as the difference in elevation between the maximum upstream water level and the invert of the outlet pipe where the **HYDROVEX**[®] flow regulator is to be installed.*

PLEASE NOTE THAT WHEN REQUESTING A PROPOSAL, WE SIMPLY REQUIRE THAT YOU PROVIDE US WITH THE FOLLOWING:

- *project design flow rate*
- *pressure head*
- *chamber's outlet pipe diameter and type*



Typical VHV model in factory

OPTIONS



FV – SVHV (mounted on sliding plate)



VHV-1-O (standard model with odour control inlet)

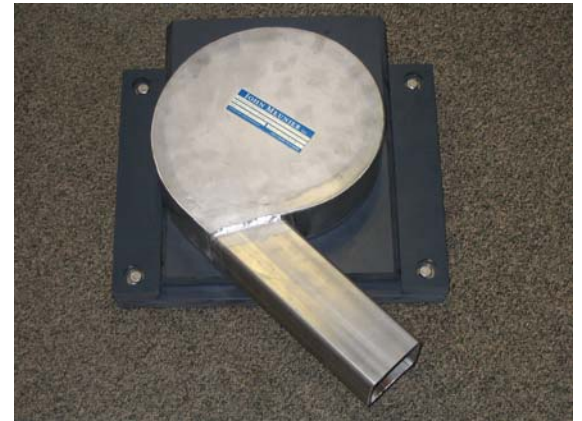

FV – VHV-O (mounted on sliding plate with odour control inlet)



VHV with Gooseneck assembly in existing chamber without minimum release at the bottom



VHV with air vent for minimal slopes



VHV Vertical Vortex Flow Regulator

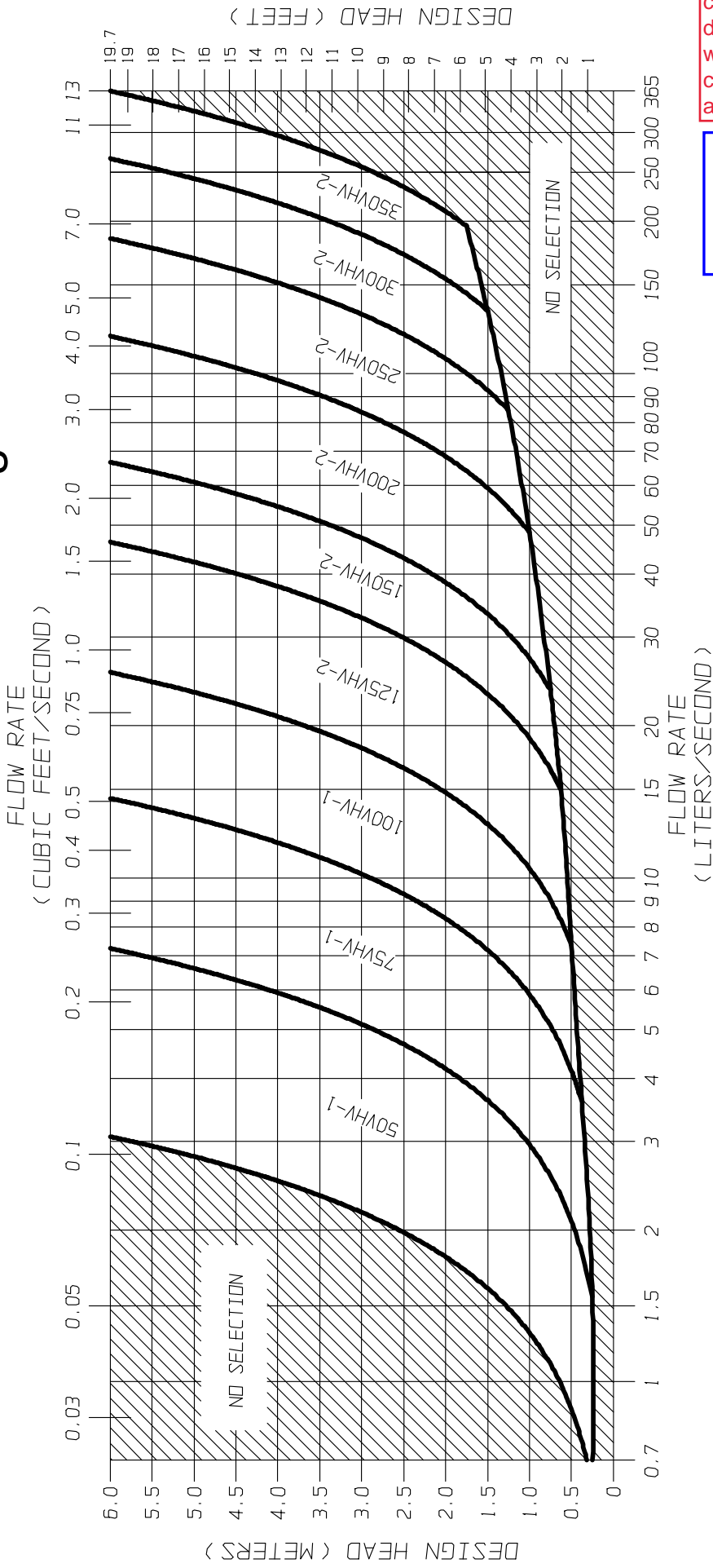

Please provide completed charts to determine which model was selected for each controlled drainage area.

PDC Response: Ok. ProjectCo to clearly identify how ICD models were selected, if applicable.

FIGURE 3 - VHV

JOHN MEUNIER



SVHV Vertical Vortex Flow Regulator

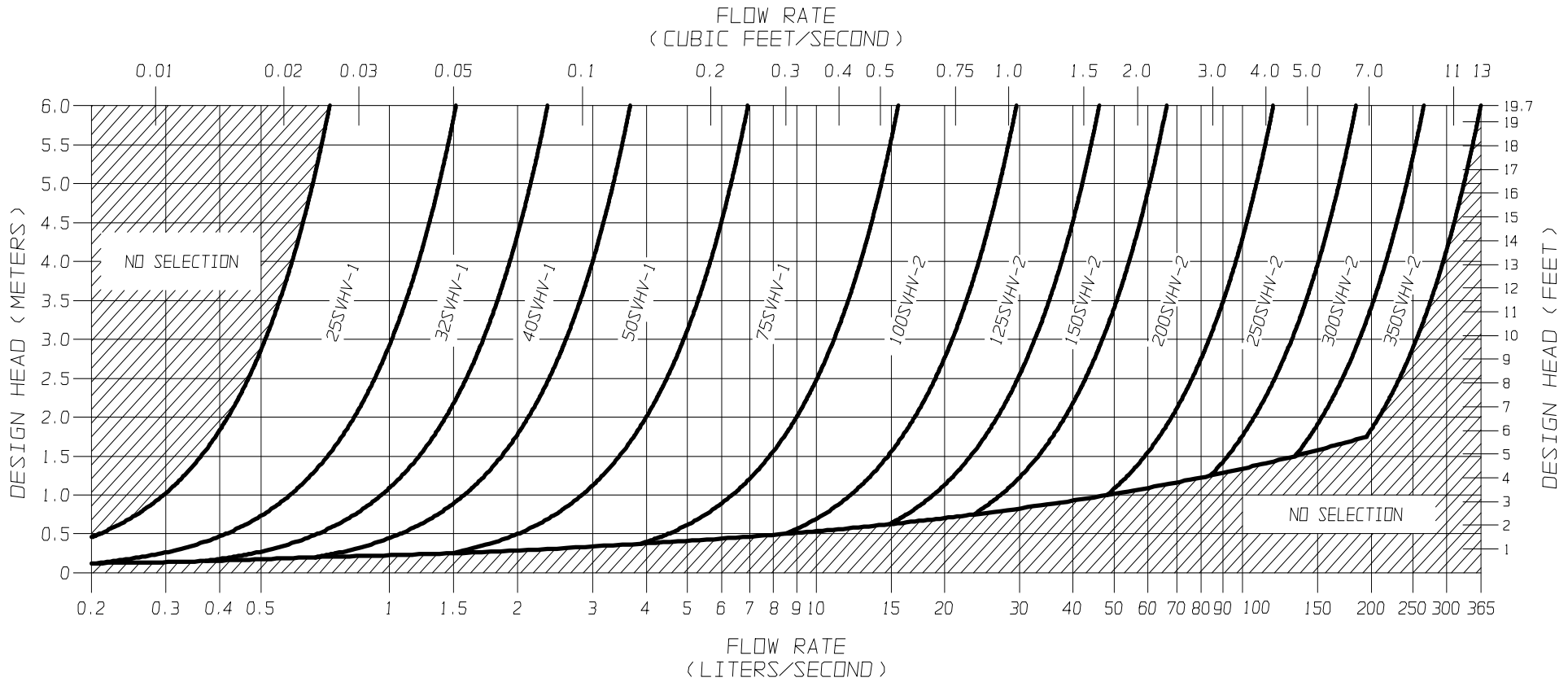
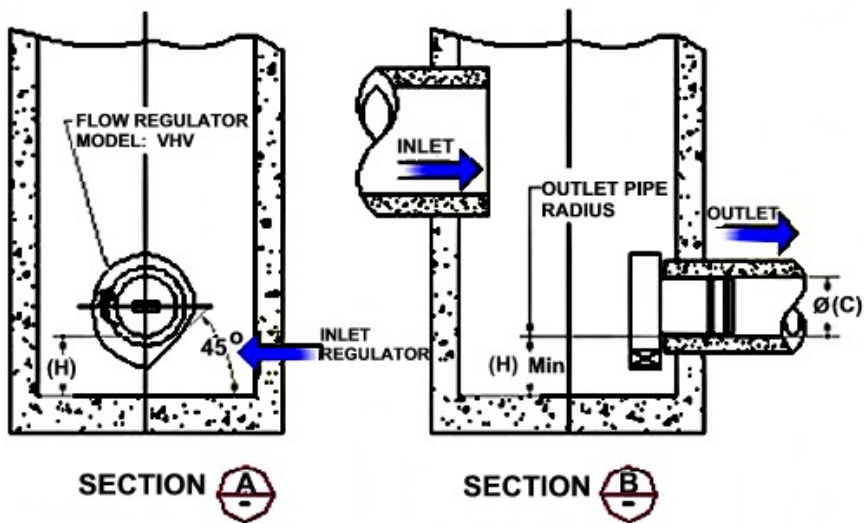
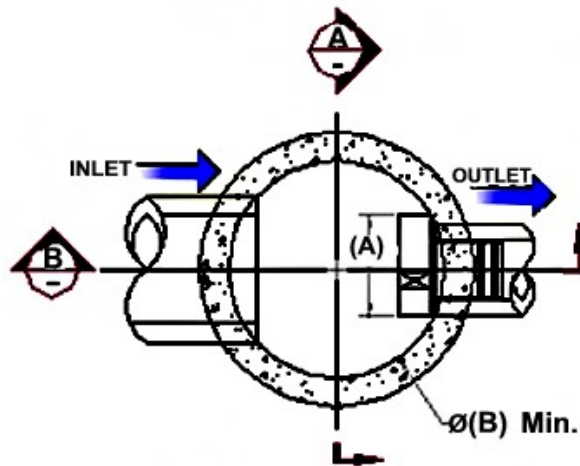

FIGURE 3 - SVHV

JOHN MEUNIER

**FLOW REGULATOR TYPICAL INSTALLATION IN CIRCULAR MANHOLE
FIGURE 4 (MODEL VHV)**

| Model Number | Regulator Diameter | | Minimum Manhole Diameter | | Minimum Outlet Pipe Diameter | | Minimum Clearance | |
|--------------|--------------------|---------|--------------------------|---------|------------------------------|---------|-------------------|---------|
| | A (mm) | A (in.) | B (mm) | B (in.) | C (mm) | C (in.) | H (mm) | H (in.) |
| 50VHV-1 | 150 | 6 | 600 | 24 | 150 | 6 | 150 | 6 |
| 75VHV-1 | 250 | 10 | 600 | 24 | 150 | 6 | 150 | 6 |
| 100VHV-1 | 325 | 13 | 900 | 36 | 150 | 6 | 200 | 8 |
| 125VHV-2 | 275 | 11 | 900 | 36 | 150 | 6 | 200 | 8 |
| 150VHV-2 | 350 | 14 | 900 | 36 | 150 | 6 | 225 | 9 |
| 200VHV-2 | 450 | 18 | 1200 | 48 | 200 | 8 | 300 | 12 |
| 250VHV-2 | 575 | 23 | 1200 | 48 | 250 | 10 | 350 | 14 |
| 300VHV-2 | 675 | 27 | 1600 | 64 | 250 | 10 | 400 | 16 |
| 350VHV-2 | 800 | 32 | 1800 | 72 | 300 | 12 | 500 | 20 |



FLOW REGULATOR TYPICAL INSTALLATION IN CIRCULAR MANHOLE
FIGURE 4 (MODEL SVHV)

| Model Number | Regulator Diameter | | Minimum Manhole Diameter | | Minimum Outlet Pipe Diameter | | Minimum Clearance | |
|--------------|--------------------|---------|--------------------------|---------|------------------------------|---------|-------------------|---------|
| | A (mm) | A (in.) | B (mm) | B (in.) | C (mm) | C (in.) | H (mm) | H (in.) |
| 25 SVHV-1 | 125 | 5 | 600 | 24 | 150 | 6 | 150 | 6 |
| 32 SVHV-1 | 150 | 6 | 600 | 24 | 150 | 6 | 150 | 6 |
| 40 SVHV-1 | 200 | 8 | 600 | 24 | 150 | 6 | 150 | 6 |
| 50 SVHV-1 | 250 | 10 | 600 | 24 | 150 | 6 | 150 | 6 |
| 75 SVHV-1 | 375 | 15 | 900 | 36 | 150 | 6 | 275 | 11 |
| 100 SVHV-2 | 275 | 11 | 900 | 36 | 150 | 6 | 250 | 10 |
| 125 SVHV-2 | 350 | 14 | 900 | 36 | 150 | 6 | 300 | 12 |
| 150 SVHV-2 | 425 | 17 | 1200 | 48 | 150 | 6 | 350 | 14 |
| 200 SVHV-2 | 575 | 23 | 1600 | 64 | 200 | 8 | 450 | 18 |
| 250 SVHV-2 | 700 | 28 | 1800 | 72 | 250 | 10 | 550 | 22 |
| 300 SVHV-2 | 850 | 34 | 2400 | 96 | 250 | 10 | 650 | 26 |
| 350 SVHV-2 | 1000 | 40 | 2400 | 96 | 250 | 10 | 700 | 28 |

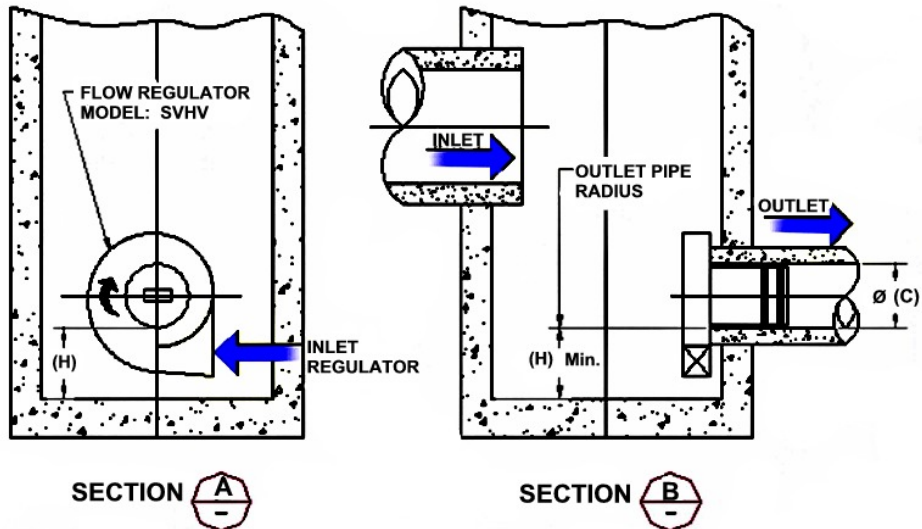
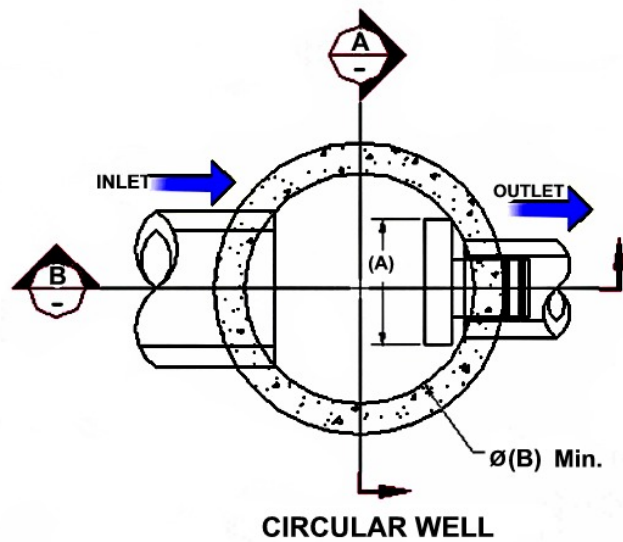

**FLOW REGULATOR TYPICAL INSTALLATION IN SQUARE MANHOLE
FIGURE 4 (MODEL VHV)**

| Model Number | Regulator Diameter | | Minimum Chamber Width | | Minimum Outlet Pipe Diameter | | Minimum Clearance | |
|--------------|--------------------|---------|-----------------------|---------|------------------------------|---------|-------------------|---------|
| | A (mm) | A (in.) | B (mm) | B (in.) | C (mm) | C (in.) | H (mm) | H (in.) |
| 50VHV-1 | 150 | 6 | 600 | 24 | 150 | 6 | 150 | 6 |
| 75VHV-1 | 250 | 10 | 600 | 24 | 150 | 6 | 150 | 6 |
| 100VHV-1 | 325 | 13 | 600 | 24 | 150 | 6 | 200 | 8 |
| 125VHV-2 | 275 | 11 | 600 | 24 | 150 | 6 | 200 | 8 |
| 150VHV-2 | 350 | 14 | 600 | 24 | 150 | 6 | 225 | 9 |
| 200VHV-2 | 450 | 18 | 900 | 36 | 200 | 8 | 300 | 12 |
| 250VHV-2 | 575 | 23 | 900 | 36 | 250 | 10 | 350 | 14 |
| 300VHV-2 | 675 | 27 | 1200 | 48 | 250 | 10 | 400 | 16 |
| 350VHV-2 | 800 | 32 | 1200 | 48 | 300 | 12 | 500 | 20 |

NOTE: *In the case of a square manhole, the outlet flow pipe must be centered on the wall to ensure enough clearance for the unit.*

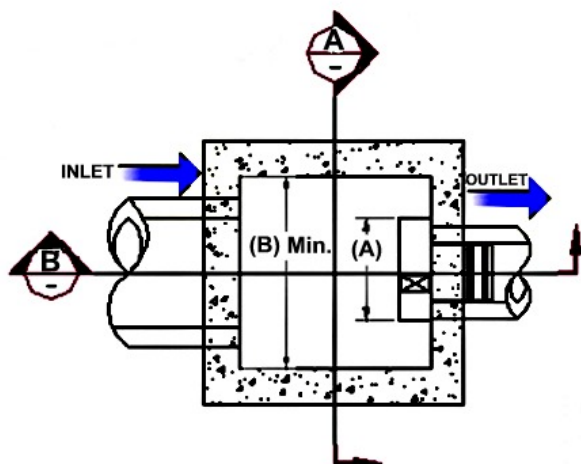

SQUARE / RECTANGULAR WELL

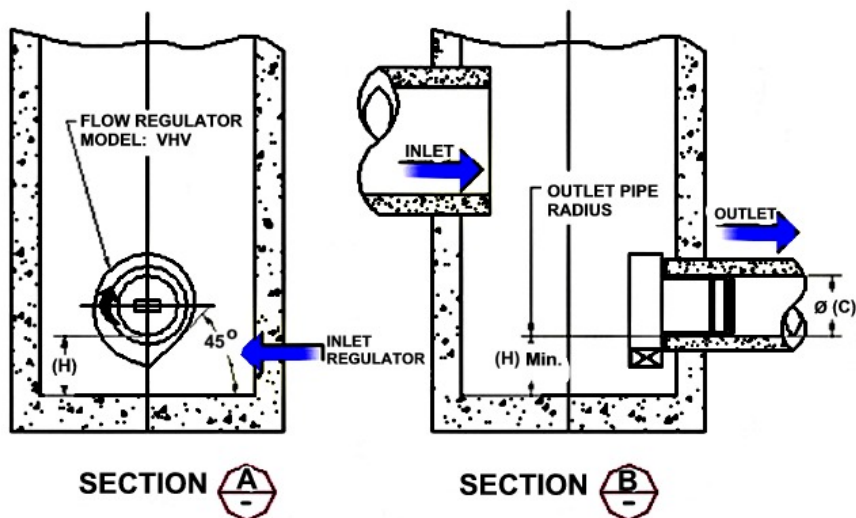

SECTION A

SECTION B

FLOW REGULATOR TYPICAL INSTALLATION IN SQUARE MANHOLE
FIGURE 4 (MODEL SVHV)

| Model Number | Regulator Diameter | | Minimum Chamber Width | | Minimum Outlet Pipe Diameter | | Minimum Clearance | |
|--------------|--------------------|---------|-----------------------|---------|------------------------------|---------|-------------------|---------|
| | A (mm) | A (in.) | B (mm) | B (in.) | C (mm) | C (in.) | H (mm) | H (in.) |
| 25 SVHV-1 | 125 | 5 | 600 | 24 | 150 | 6 | 150 | 6 |
| 32 SVHV-1 | 150 | 6 | 600 | 24 | 150 | 6 | 150 | 6 |
| 40 SVHV-1 | 200 | 8 | 600 | 24 | 150 | 6 | 150 | 6 |
| 50 SVHV-1 | 250 | 10 | 600 | 24 | 150 | 6 | 150 | 6 |
| 75 SVHV-1 | 375 | 15 | 600 | 24 | 150 | 6 | 275 | 11 |
| 100 SVHV-2 | 275 | 11 | 600 | 24 | 150 | 6 | 250 | 10 |
| 125 SVHV-2 | 350 | 14 | 600 | 24 | 150 | 6 | 300 | 12 |
| 150 SVHV-2 | 425 | 17 | 600 | 24 | 150 | 6 | 350 | 14 |
| 200 SVHV-2 | 575 | 23 | 900 | 36 | 200 | 8 | 450 | 18 |
| 250 SVHV-2 | 700 | 28 | 900 | 36 | 250 | 10 | 550 | 22 |
| 300 SVHV-2 | 850 | 34 | 1200 | 48 | 250 | 10 | 650 | 26 |
| 350 SVHV-2 | 1000 | 40 | 1200 | 48 | 250 | 10 | 700 | 28 |

NOTE: *In the case of a square manhole, the outlet flow pipe must be centered on the wall to ensure enough clearance for the unit.*

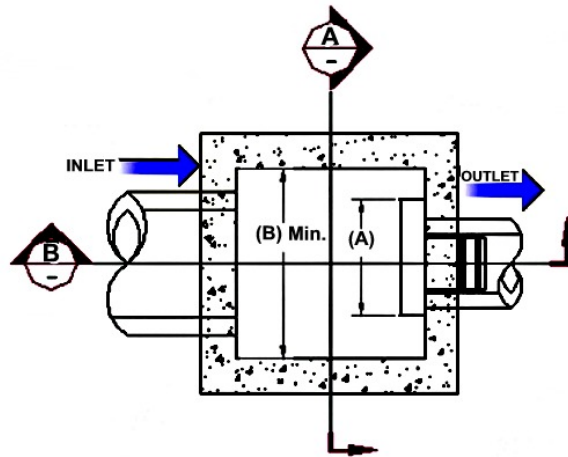

SQUARE / RECTANGULAR WELL

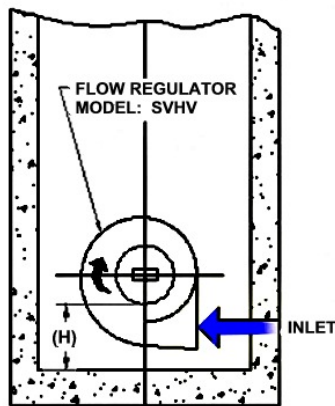

SECTION A

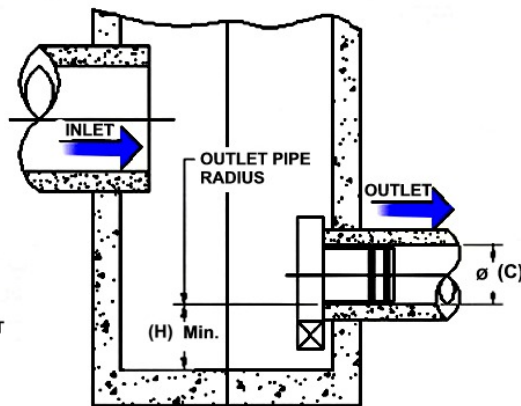

SECTION B

INSTALLATION

The installation of a **HYDROVEX**[®] regulator may be undertaken once the manhole and piping is in place. Installation consists of simply fitting the regulator into the outlet pipe of the manhole. **John Meunier Inc.** recommends the use of a lubricant on the outlet pipe, in order to facilitate the insertion and orientation of the flow controller.

MAINTENANCE

HYDROVEX[®] regulators are manufactured in such a way as to be maintenance free; however, a periodic inspection (every 3-6 months) is suggested in order to ensure that neither the inlet nor the outlet has become blocked with debris. The manhole should undergo periodically, particularly after major storms, inspection and cleaning as established by the municipality

GUARANTY

The **HYDROVEX**[®] line of **VHV / SVHV** regulators are guaranteed against both design and manufacturing defects for a period of 5 years. Should a unit be defective, **John Meunier Inc.** is solely responsible for either modification or replacement of the unit.

John Meunier Inc.

ISO 9001 : 2008

Head Office

4105 Sartelon

Saint-Laurent (Quebec) Canada H4S 2B3

Tel.: 514-334-7230 www.johnmeunier.com

Fax: 514-334-5070 cs@johnmeunier.com

Ontario Office

2000 Argentia Road, Plaza 4, Unit 430

Mississauga (Ontario) Canada L5N 1W1

Tel.: 905-286-4846 www.johnmeunier.com

Fax: 905-286-0488 ontario@johnmeunier.com

USA Office

2209 Menlo Avenue

Glenside, PA USA 19038

Tel.: 412-417-6614 www.johnmeunier.com

Fax: 215-885-4741 astele@johnmeunier.com