



COPYRIGHT NOTICE
THIS DRAWING AND DESIGN IS COPYRIGHT PROTECTED.
DO NOT REPRODUCE OR REVISE WITHOUT WRITTEN PERMISSION BY ARCHITECTURE49 INC.



THIS BAR IS 25mm LONG WHEN PLOTTED AT CORRECT SCALE. DO NOT SCALE DRAWINGS.

NORTH ARROW: DIGITAL REFERENCE:

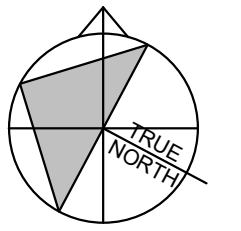

PROJECT NO.: 229-00058-11 CONTRACT NO.

DRAWN BY: NMAS CHECKED BY: JCAB APPROVED BY: Approver

KEYPLAN:

2023.11.13 ISSUED FOR SITE PLAN RESUBMISSION
2023.09.20 ISSUED FOR SITE PLAN RESUBMISSION
NO. DATE ISSUED

PROJECT

**ACCESS STORAGE
75 MICHAEL COWPLAND DRIVE**

DRAWING TITLE

SITE PLAN - GENERAL

DRAWING NO.

A101

#18895

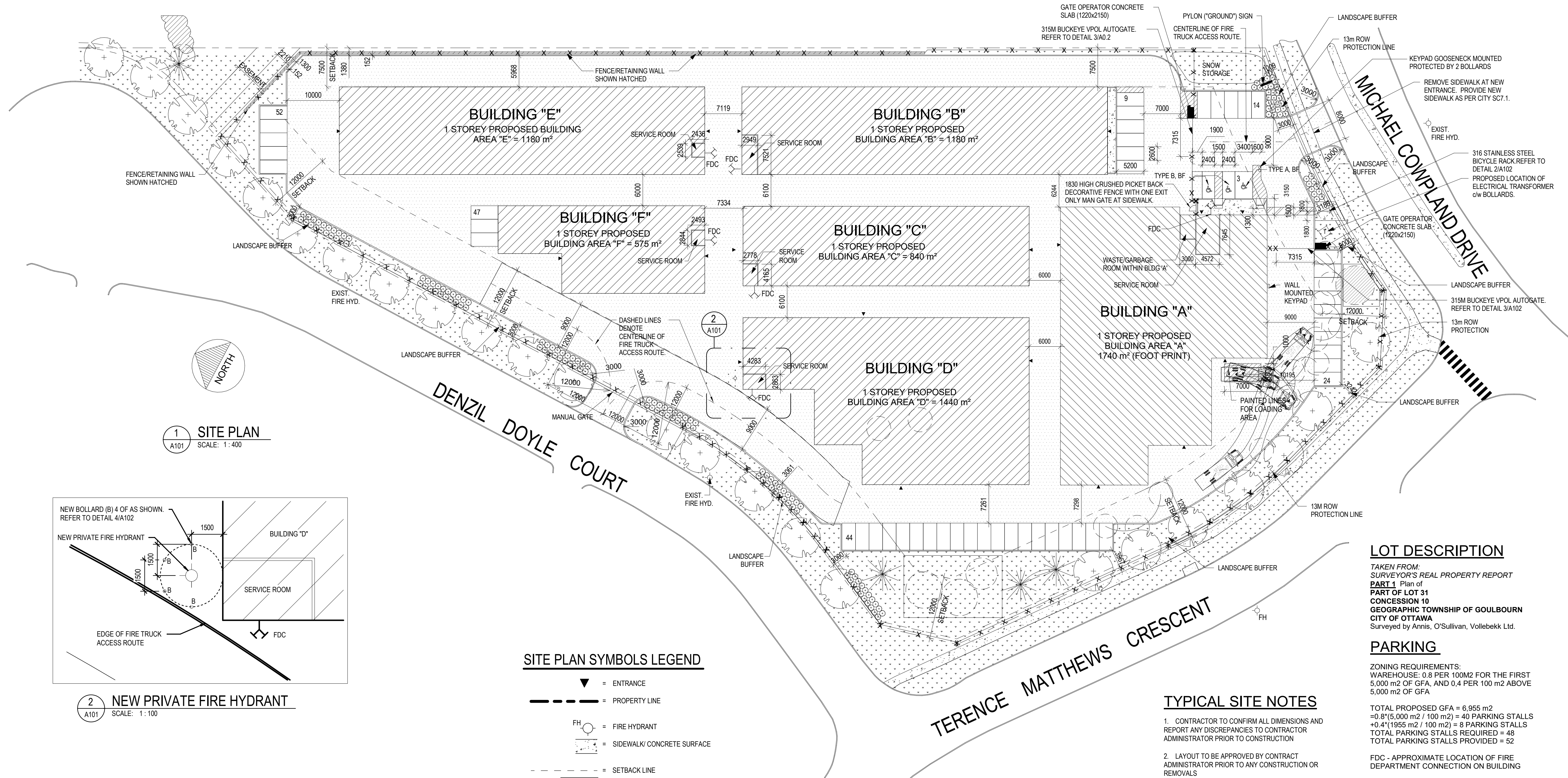

1 SITE PLAN
A101 SCALE: 1:400

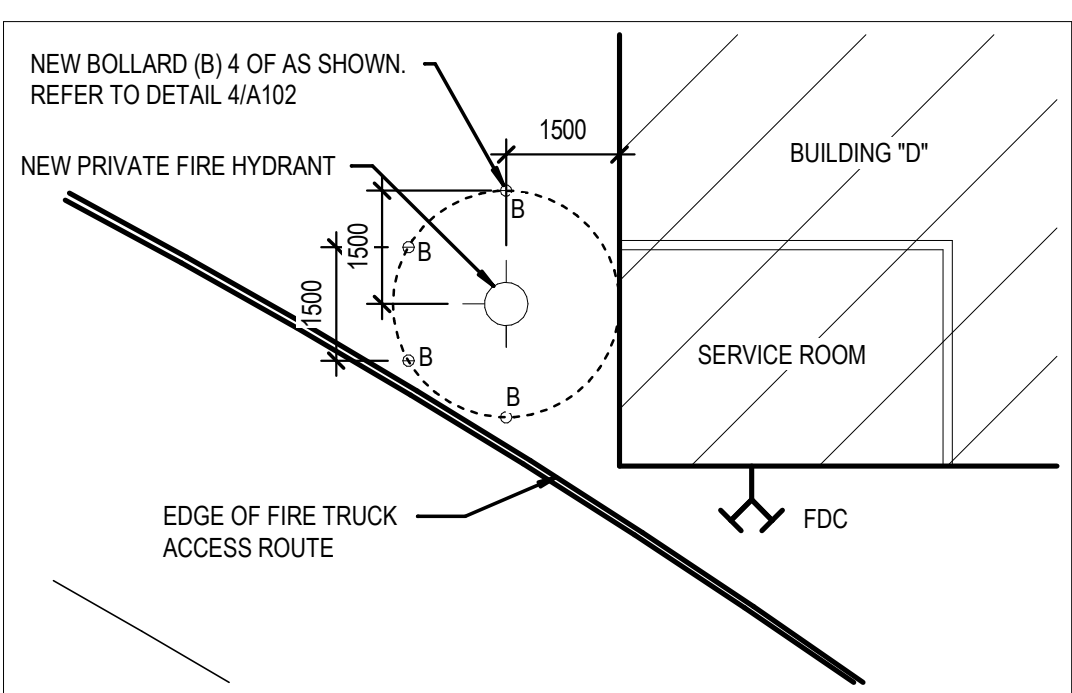

2 NEW PRIVATE FIRE HYDRANT
A101 SCALE: 1:100

SITE PLAN SYMBOLS LEGEND

- ▼ = ENTRANCE
- — — = PROPERTY LINE
- FH = FIRE HYDRANT
- = SIDEWALK/ CONCRETE SURFACE
- - - = SETBACK LINE
- = GRASS
- X — X — X = FENCE LINE
- ▨ = LANDSCAPING
- ▨ = ASPHALT
- ▨ = PAINTED LINES
- T = PADMOUNT TRANSFORMER BY HYDRO OTTAWA. PROVIDE TRANSFORMER BASE TO HYDRO OTTAWA STANDARDS. PRECAST TRANSFORMER BASE AND BOLLARDS BY GENERAL CONTRACTOR. REFER TO HYDRO OTTAWA STANDARD DETAILS UFS0001, UGS0002 AND UTS0038.
- = BOLLARD
- = DENOTES TREE TO BE REMOVED
- = DENOTES TREE TO REMAIN
- ☼ = DENOTES NEW TREE. REFER TO LANDSCAPE
- ☼ = DENOTES NEW TREE. REFER TO LANDSCAPE

ZONING

75 Michael Cowpland Drive
SITE INFORMATION
Legal Description:
Part of Lot 31, Concession 10, Geographic Township of Goulbourn, City of Ottawa
Municipal Address:
75 Michael Cowpland Drive, Kanata, ON
Site Area:
16,575 m² (178,411.8 ft²)
Building Area:
Existing: N/A
Proposed: 8,243 m² (88,726.91 ft²)
ZONING INFORMATION:
Zoning:
Business Park Industrial, Subzone 4 – Kanata South Business Park (IP4)
Lot Coverage (Sec 205, Table 205):
Required: 55% (maximum)
Proposed: 41%
Building Height (Sec. 205, Table 205(h)):
Required: 22 m (maximum)
Proposed: 6.6 m
Floor Space Index (Sec. 205, Table 205(g)):
Required: 2 (maximum)
Proposed: 0.5
Required Yards (Sec. 206, Table 206B):
Min. Front Yard: Building A - 12 m (12 m required)
Min. Interior Side Yard: Buildings B and E - 7.5 m (7.5 m required)
Min. Rear Side Yard: 12 m (7.5 m required)

TYPICAL SITE NOTES

1. CONTRACTOR TO CONFIRM ALL DIMENSIONS AND REPORT ANY DISCREPANCIES TO CONTRACTOR ADMINISTRATOR PRIOR TO CONSTRUCTION
2. LAYOUT TO BE APPROVED BY CONTRACT ADMINISTRATOR PRIOR TO ANY CONSTRUCTION OR REMOVALS
3. ALL DIMENSIONS ARE IN METRIC UNLESS OTHERWISE NOTED
4. CONTRACTOR IS RESPONSIBLE FOR ALL EXCAVATIONS, REMOVALS, DISPOSALS AND ROUGH GRADING AS REQUIRED TO CONSTRUCTION ALL WORKS AS SHOWN ON ALL PLANS, DETAILS AND SPECIFICATIONS
5. LOCATION OF ALL UTILITIES SHOWN FOR ILLUSTRATION ONLY. CONTRACTOR MUST CONTACT ALL UTILITIES REGARDING RULES FOR WORKING IN THE AREA OF THE UTILITIES PRIOR TO COMMENCEMENT OF ANY WORK. CONTRACTOR MUST CONFIRM LOCATION OF ALL UTILITIES PRIOR TO CONSTRUCTION
6. ALL EXISTING ROADS, SIDEWALKS, CURBS, FENCING, PAVING, SODDED AREAS, AND APPROACHES, ETC. TO REMAIN TO BE PROTECTED DURING CONSTRUCTION TO CONTRACT ADMINISTRATOR'S APPROVAL AT THE CONTRACTOR'S OWN COSTS.
7. ALL EXISTING TREES, SHRUB BEDS, MULCH BEDS, AND SOD TO REMAIN TO BE PROTECTED DURING CONSTRUCTION. AREAS DAMAGED DURING CONSTRUCTION TO BE REPAIRED TO CONTRACT ADMINISTRATOR'S APPROVAL AT THE CONTRACTOR'S OWN COST.
8. USE SPECIFIED BACKFILL IN ALL TRENCHES RUNNING BELOW ALL STRUCTURES, PAVING, WALKWAYS, ETC.
9. FILL ALL HOLES AND LOW AREAS TO DESIGN SUBGRADE WITH COMPACTED FILL (SUITABLE TO SURFACE FINISH). FOR SODDED/PLANTED AREAS USE COMPACTED CLEAN EARTH FILL SUITABLE FOR PLANT GROWTH. FOR PAVED AREAS USE COMPACTED GRANULAR BASE.
10. ALL TREES WITHIN OR IMMEDIATELY ADJACENT TO AREA OF WORK TO BE PROTECTED TO CITY OF OTTAWA TREE PROTECTION STANDARDS.
11. REFER TO LANDSCAPE DRAWINGS FOR LOCATIONS OF ALL EXISTING, REMOVED, AND PROPOSED TREE AND SHRUB PLANTING

LOT DESCRIPTION

TAKEN FROM:
SURVEYOR'S REAL PROPERTY REPORT
PART 1 Plan of
PART OF LOT 31
CONCESSION 10
GEOGRAPHIC TOWNSHIP OF GOULBOURN
CITY OF OTTAWA
Surveyed by Annis, O'Sullivan, Vollebakk Ltd.

PARKING

ZONING REQUIREMENTS:
WAREHOUSE: 0.8 PER 100M² FOR THE FIRST 5,000 m² OF GFA, AND 0.4 PER 100 m² ABOVE 5,000 m² OF GFA
TOTAL PROPOSED GFA = 6,955 m²
= 0.8(5,000 m² / 100 m²) = 40 PARKING STALLS
+ 0.4(1955 m² / 100 m²) = 8 PARKING STALLS
TOTAL PARKING STALLS REQUIRED = 48
TOTAL PARKING STALLS PROVIDED = 52
FDC - APPROXIMATE LOCATION OF FIRE DEPARTMENT CONNECTION ON BUILDING NOTED

SITE SUMMARY

EXISTING LOT AREA 16575 SQ.M
PROPOSED BUILDING "A" 1740 SQ.M
PROPOSED BUILDING "B" 1180 SQ.M
PROPOSED BUILDING "C" 840 SQ.M
PROPOSED BUILDING "D" 1440 SQ.M
PROPOSED BUILDING "E" 1180 SQ.M
PROPOSED BUILDING "F" 575 SQ.M
TOTAL PROPOSED G.F.A. 6,955 SQ.M
LOT COVERAGE 6955 42% PROPOSED
THE MAXIMUM PERMITTED LOT COVERAGE IS 55% AS PER TABLE 205(C)

ONTARIO BUILDING CODE

1. SITE PLAN AND BUILDING DESIGN IS BASED ON "SECTION 3.10. SELF-SERVICE STORAGE BUILDINGS".
2. OCCUPANCY CLASSIFICATION IS F-2, BUILDING IS SPRINKLERED. CONSTRUCTION IS NON-COMBUSTIBLE. OCCUPANT LOAD DOES NOT APPLY.
3. SPATIAL SEPARATIONS DOES NOT APPLY BETWEEN BUILDINGS AS PER OBC 3.10.4.3 (4). THE DISTANCE BETWEEN INDIVIDUAL BUILDINGS SHALL NOT BE LESS THAN 6M.
4. PER OBC 3.10, PROVISIONS FOR FIRE FIGHTING MEETS 9M WIDE ACCESS ROUTE AND UNOBSTRUCTED PATH OF TRAVEL FOR THE FIREFIGHTER FROM THE VEHICLE TO THE FIRE DEPARTMENT CONNECTION (FDC) OF MAX. 45M.
5. BUILDING IS EXEMPT PER OBC, MMA SUPPLEMENTARY STANDARD SB-10, DIVISION 3, ENERGY EFFICIENCY DESIGN AFTER DECEMBER 31, 2016, PER SECTION 1.2.1.1 (1)(d) AND 1.2.1.1 (2)(b).