



Kollaard Associates

Engineers

210 Prescott Street, Unit 1

P.O. Box 189

Kemptville, Ontario K0G 1J0

Civil • Geotechnical •
Structural • Environmental •
Hydrogeology

(613) 860-0923

FAX: (613) 258-0475

**STORMWATER
MANAGEMENT REPORT**

Proposed Residential Development
3430 Carling Avenue
OTTAWA, ONTARIO

Prepared For:
Rohit Communities Ontario Inc.
550 91 Street SW, Suite 101
Edmonton, Alberta
T6X 0V1

PROJECT #: 220978

DISTRIBUTION

3 copies – City of Ottawa

1 copy – Rohit Communities Ontario Inc.

1 copy – Kollaard Associates Inc.

Rev 0 – Issued for Site Plan Approval

Rev 1 – Response to First Review Comment

December 14, 2022

March 28, 2023



Professional Engineers
Ontario

Authorized by the Association of Professional Engineers
Of Ontario to offer professional engineering services



TABLE OF CONTENTS

1 INTRODUCTION.....1

2 STORMWATER DESIGN2

 2.1 Background2

 2.2 Stormwater Management Design Criteria2

 2.2.1 Quantity Control Design Criteria.....2

 2.2.2 Quality Control Design Criteria.....2

 2.3 Stormwater Quantity Control3

 2.3.1 Methodology3

 2.3.2 Runoff Coefficients3

 2.3.3 Pre-development Site Conditions.....4

 2.3.4 Time of Concentration4

 2.3.5 Pre-development Runoff Coefficient5

 2.3.6 Pre-development Flow Rate.....5

 2.3.7 Post-Development Controlled and Uncontrolled Areas.....6

 2.3.8 Uncontrolled Runoff.....7

 2.3.9 Allowable Release Rate7

 2.3.10 Post Development Restricted Flow and Storage.....8

 2.3.11 Rooftop Storage9

 2.3.12 Underground Storage.....10

 2.4 Stormwater Quality Control11

 2.5 Stormwater System Operation and Maintenance.....12

 2.5.1 Roof Drains12

 2.5.2 Catch basin / Manhole.....12

 2.5.3 Stormwater Storage Tanks.....12

 2.5.4 Inspections13

3 STORM SEWER DESIGN AND SUFFICIENCY OF EXISTING MUNICIPAL STORM SEWER13

 3.1 Storm Sewer Design13

 3.2 Existing Storm Sewer13

4 EROSION AND SEDIMENT CONTROL.....14

5 CONCLUSIONS.....15



LIST OF APPENDICES

- Appendix A: Storm Design Information
- Appendix B: Product Information and Roof Drawings
- Appendix C: Correspondence
- Appendix D: Drawings

LIST OF DRAWINGS

- 220978– PRE – Pre-Development Conditions
- 220978 –SWMP – Stormwater Management Plan and Catchment Areas
- 220978 – GR – Grading Plan
- 220978 – SER – Site Servicing Plan
- 220978 – ER – Erosion Control Plan



Kollaard Associates

Engineers

210 Prescott Street, Unit 1

P.O. Box 189

Kemptville, Ontario K0G 1J0

Civil • Geotechnical •
Structural • Environmental •
Hydrogeology

(613) 860-0923

FAX: (613) 258-0475

1 INTRODUCTION

Kollaard Associates was retained by Rohit Communities Ontario Inc. to complete a Stormwater Management Report for a proposed residential development, consisting of two 6-storey apartment buildings.

This report will summarize the stormwater management (SWM) design requirements and proposed works that will address stormwater flows arising from the site under post-development conditions. The report will identify any stormwater servicing concerns and also describe any measures to be taken during construction to minimize erosion and sedimentation. This report will also address the capacity of the existing municipal storm sewer to hydraulically convey the stormwater runoff from the site.

The proposed development is located at 3430 Carling Avenue, Ottawa, Ontario. The property is on the south side of Carling Avenue between Ullswater Drive and Crystal Beach Drive.

The site has a total area of 0.62 hectares and is currently occupied by a 1-storey commercial building. It is understood that the existing building will be removed and two new residential buildings with approximate footprints of 1342 square meters and 1270 square meters respectively will be constructed. The proposed development is to consist of a two 6-storey buildings interconnected by 2 levels of underground parking.

On-site stormwater detention will be provided and the discharge rate from the stormwater storage will be restricted to ensure that the post-development runoff rate from the site during a 1 to 100 year design storm will be less than or equal to the predevelopment runoff rate for a 5 year design storm event with a runoff coefficient of 0.5. The stormwater storage requirements will be met for all design storm events up to and including the 100-year design storm on the roofs of the proposed buildings and in underground storage tanks adjacent to the south side of the underground parking.

Calculations of the required storage volumes have been prepared based on the modified Rational Method as identified in Section 5.4 and Section 8.3.10.3 of the City's Sewer Guidelines.

Design of the stormwater management system was completed in conformance with the City of Ottawa Sewer Design Guidelines (October 2012 as amended).



Professional Engineers
Ontario

Authorized by the Association of Professional Engineers
Of Ontario to offer professional engineering services



2 STORMWATER DESIGN

2.1 Background

The majority of the runoff from the existing property currently drains by a combination of overland sheet flow towards the north flowing onto Carling Avenue, and into a storm manhole which outlets to the storm sewer along Carling Avenue.

The Storm sewer along Carling Avenue to the west of the site consists of a 525mm diameter concrete pipe, which increases in size to 600mm at storm manhole MHST52076. The storm sewer directly adjacent to the site along Carling Avenue consists of a 600 mm diameter concrete pipe. The diameter of the storm sewer increases to 675mm diameter east of the site at storm manhole MHST52081.

2.2 Stormwater Management Design Criteria

The SWM design criteria was provided by the City of Ottawa as a part of a previous SWM project completed by J.J Richards & Associates Limited. (JLR No.: 3114-001). The stormwater management criteria was summarized in the Pre-Consultation Meeting Notes (Included in Appendix C).

2.2.1 Quantity Control Design Criteria

The quantity control design criteria were provided by the City of Ottawa and are as follows:

- Design Storm for receiving sewer: 5-design Storm;
- Runoff Coefficient to model pre-development conditions is to be the lesser of $C = 0.5$ or $C =$ pre-development;
- Time of Concentration (T_c) to be calculated. Minimum $T_c = 10$ minutes;
- The post-development runoff rate from a 100-year storm event is to be controlled to the 5-year pre-development runoff rate.
- Storm sewers to be designed and sized based on the rational formula and the Manning's Equation under free flow conditions for the 5-year storm using a 10-minute inlet time.
- If underground/inline stormwater storage is proposed, an average release rate equal to 50% of the determined peak allowable rate must be used. Otherwise, disregard the underground/inline storage as available storage or provide modeling to support the proposed design.

2.2.2 Quality Control Design Criteria

Kollaard Associates has reached out to Rideau Valley Conservation Authority to obtain the quality control design criteria for the site. At time this report was prepared, no criteria has been provided. Since the discharge from the site is being directed into an existing storm sewer



system it has been assumed that there will be no quality control design control requirements for the site. Best management practices will be incorporated where possible to reduce the potential transport of pollutants from the site to the storm sewer system.

2.3 Stormwater Quantity Control

2.3.1 Methodology

The peak flow and runoff rates for quantity control purposes during both Pre-Development and Post-Development stages of the project were calculated using the rational method. The rational method is a common and straightforward calculation, which assumes that the entire drainage area is subject to uniformly distributed rainfall. The formula is:

$$Q = \frac{CiA}{360}$$

Where

Q is the Peak runoff measured in m^3/s

C is the Runoff Coefficient, Dimensionless

A is the runoff area in *hectares*

i is the storm intensity measure in mm/hr

All values for intensity, *i*, for this project were derived from IDF curves provided by the City of Ottawa for data collected at the Ottawa International airport. For this project two return periods were considered, 5 and 100-year events. The formulas for each are:

5-Year Event

$$i = \frac{998.071}{(t_c + 6.053)^{0.814}}$$

100-Year Event

$$i = \frac{1735.688}{(t_c + 6.014)^{0.82}}$$

Where t_c is time of concentration

2.3.2 Runoff Coefficients

Runoff coefficients for impervious surfaces (roofs, asphalt, and concrete) were taken as 0.90, gravel areas were taken as 0.60, patio stones were taken as 0.7 and pervious surfaces (grass) were taken as 0.20.



A 25% increase for the post development 100-year runoff coefficients was used as per City of Ottawa guidelines.

2.3.3 Pre-development Site Conditions

As previously indicated, the site is located at 3430 Carling Avenue. The property has a total area of about 0.62 hectares and is currently occupied by a 1 -storey commercial building.

The adjacent property to the west is a community of mid-rise apartment buildings and townhouses serviced with an asphalt parking lot. Limited topographic data and available aerial photography indicate that the abutting parking lot drains away from the subject site and as such will not contribute offsite runoff to pre-development conditions.

The adjacent property to east is a 1 storey commercial building used as the diner with a joined gas station which is serviced by an asphalt parking lot. Limited topographic data and available aerial maps indicate that the abutting parking lot drains away from the subject site and as such, will not contribute to offsite runoff to pre-development conditions.

The adjacent properties to the south consist of single family dwellings with soft landscaping in the north (rear) yards with a hedge separating the subject side from the neighbouring lots. Limited topographic data and available aerial maps indicate that the abutting lots have a high point in the rear yard that drains away from the subject site, and as such will not contribute to offsite runoff to pre-development conditions.

Drawing 220978-PRE Pre-development Conditions shows the pre-development conditions and catchment areas considered for the proposed development.

2.3.4 Time of Concentration

The time of concentration for pre-development conditions was determined by the use of the Bransby-William's Formula. The maximum length of flow under pre-development conditions is about 100 metres towards a catch basin in the asphalt parking lot, which outlets to the existing 600mm storm sewer along Carling Avenue, and about 50 metres towards the north property line along Carling Avenue. The existing ground surface is sloped to the catch basin in the asphalt parking lot at about 0.2 percent and toward Carling Avenue at about 0.6 to 1.5 percent. The existing ground surface is mostly covered with asphaltic concrete pavement and has a runoff coefficient for pre-development conditions of 0.83 as indicated in section 2.3.5 of this report. The Bransby William's formula was used on the portion of the parking lot which drains into the existing storm manhole, which outlets into the existing storm sewer on Carling Avenue. The Bransby Williams Formula is:

$$t_c = \frac{0.057 * L}{S_w^{0.2} * A^{0.1}}$$



From the formula, a length of 100 metres, combined with a slope of 0.2 percent and an asphalt pavement surface results in an inlet time of about 8.3 minutes. Since the minimum time of concentration to be used is 10 minutes, a time of concentration of 10 minutes was used to model pre-development conditions and post-development uncontrolled runoff conditions.

2.3.5 Pre-development Runoff Coefficient

Pre-development site conditions are summarised in the following Table 2-1.

Table 2-1 – Summary of Pre-Development Runoff Coefficients

PRE-DEVELOPMENT			
Description	Runoff Coefficient		Area (ha)
	5-year	100year	
			0.616
Gravel	0.60	0.75	0.000
Asphalt/ Concrete/ Roof	0.90	1.00	0.556
Patio Stones/Pavers	0.70	0.88	0.000
Grass	0.20	0.25	0.060
Weighted Average C	0.83	0.92	

It is understood that pre-development conditions will be considered as the lesser of current conditions or conditions resulting in a runoff coefficient of 0.5.

Based on the existing ground cover the pre-development runoff coefficient was calculated to be 0.82. However, the predevelopment runoff coefficient used for the purpose of this stormwater management design is C = 0.5.

2.3.6 Pre-development Flow Rate

Using the IDF curve formula for the Ottawa International Airport with a time of concentration of 10 minutes results in a rainfall intensity of 104.19 mm/hr for a 5 year design storm. Using the Rational Method, the previously calculated runoff coefficients and a storm intensity of 104.19 mm/hr, the pre-development runoff rate for the 5-year storm is:

$$5 \text{ year} = 2.78 \times 0.5 \times 104.19 \times 0.616 = 89.3 \text{ L/s}$$

In keeping with the stormwater management criteria, the total allowable runoff rate from the site is equal to the pre-development runoff rate occurring during a 5 year storm event. As such, the total allowable post-development runoff rate for the site is 89.3 L/s.



2.3.7 Post-Development Controlled and Uncontrolled Areas

For the purposes of this storm water management design, the site has been divided into uncontrolled and controlled areas as outlined on drawing 220978-SWMP Stormwater Management Plan and Catchment Areas. The site has one uncontrolled area, and three controlled areas.

The site has one uncontrolled area. Since the building's underground parking footprint occupies the majority of the site, there is insufficient area available adjacent to the buildings to provide for appreciable detention and storage. As such, all of the surface areas in between the footprint of the building and the respective property lines are considered as one uncontrolled area (UA1). UA1 has an area of 0.209 ha and is comprised of a combination of landscaped grass areas, landscaped stone areas at the building entrances, a portion of the asphalt driveway on the northern portion of the lot, and concrete surfaces at the garage entrance. Runoff from UA1 will be conveyed by surface flow and shallow swales without restriction to Carling Avenue.

The first controlled area is comprised of the main roof of the west building. This roof area is considered as catchment 1 (CA1-west roof). The roof has an area of 0.134 ha. The west roof will be constructed to accommodate stormwater storage. Outlet from the upper roof will be restricted by ten WATTS Accutrol Roof Drains (with adjustable flow control) which will direct the roof discharge to internal stormwater plumbing that discharges to the storm service lateral connected to Carling Avenue north of the site.

The second controlled area is the main roof of the east building. This roof area is considered as catchment 2 (CA2 – east roof). The east roof section has an area of 0.128 ha. CA2 will also be constructed to accommodate stormwater storage. Discharge from the east roof will be restricted by two WATTS Accutrol Roof Drains (with adjustable flow control) which will also direct the discharge to the internal stormwater plumbing.

The third controlled area is the surface level parking and adjacent landscaping along the rear (south) of the buildings. The surface runoff from the parking area is to be captured and conveyed by trench drains into maintenance hole CBMH-MH2 and catch basins CB1, CB2, and CB3. The surface runoff from the landscaped area south of the surface parking is to be captured by shallow swales that will convey the runoff to rear-yard catch basins. The maintenance holes, catch basins and rear yard catch basins will convey the runoff by means of a storm sewer to maintenance hole STM MH1 which will in turn discharge to precast concrete underground stormwater storage tank located below the eastern drive isle of parking level P2. The stormwater tanks will be discharged by means of a duplex cistern pumping system to be determined by the mechanical engineer, which will restrict the discharge from the storage tanks during and following a rain storm event.



The following table provides a summary of the post development conditions.

Table 2-2 – Summary of Post-Development Site Conditions

Catchment Area ID.	Runoff Coefficient (5yr)	Runoff Coefficient (100yr)	Catchment Area (Ha)
Controlled CA1 (west roof)	0.90	1.00	0.134
Controlled CA2 (east roof)	0.90	1.00	0.127
Controlled CA3	0.60	0.68	0.174
Uncontrolled UA1	0.39	0.46	0.181
<i>Total</i>			<i>0.616</i>

2.3.8 Uncontrolled Runoff

Flow from the uncontrolled area will be directed without restriction towards Carling Avenue. The maximum allowable release rate from the controlled area equals the allowable post development runoff rate minus the 100-year runoff rate from the uncontrolled portion of the site.

A post-development time of concentration of 10 minutes corresponds to a storm intensity of 104.19 mm/hr and 178.56 mm/hr during the 5-year and 100-year design storm events respectively. The runoff rate from the uncontrolled areas was calculated using the Rational Method.

$$Q = \frac{CiA}{360}$$

The uncontrolled runoff for the 5 year and 100 year design storm events are as follows (calculations are provided in Appendix A):

$$5 \text{ year} = 2.78 \times 0.39 \times 104.19 \times 0.181 = 20.4 \text{ L/s}$$

$$100 \text{ year} = 2.78 \times 0.46 \times 178.56 \times 0.181 = 41.3 \text{ L/s}$$

2.3.9 Allowable Release Rate

The City of Ottawa requires that post-development stormwater runoff rate during a 100 year design storm event be limited to be less than or equal to the pre-development runoff rate, calculated assuming a maximum runoff coefficient of C=0.5, during a 5 year design storm event. To control runoff from the site it will be necessary to limit post-development flows, from the



controlled areas, for all design storm events up to and including the 100-year event using onsite inlet controls.

The allowable release rate from the controlled areas of the site is equal to the total allowable runoff rate from the site less the runoff rate from the uncontrolled areas.

$$Q_{\text{controlled}} = Q_{\text{total allowable}} - Q_{\text{uncontrolled}}$$

For the 5-year Storm event

$$Q_{\text{controlled}} = 89.3 - 20.4 \text{ L/s} = 68.9 \text{ L/s}$$

For the 100-year Storm event

$$Q_{\text{controlled}} = 89.3 - 41.3 \text{ L/s} = 48.0 \text{ L/s}$$

Since the allowable release rate for a 100 year design storm event is less than the allowable release rate for a 5 year design storm event, the flow restriction for the 100 year design storm will govern. As such, the maximum allowable release rate from the combined controlled areas of CA1, CA2 and CA3 is limited to 48.0 L/s for a 100 year storm event.

2.3.10 Post Development Restricted Flow and Storage

Runoff generated on site in excess of the allowable release rate will be temporarily stored on both roof structures; the west roof (CA1) and east roof (CA2) and in pre-cast concrete storage tanks (cisterns) below the P2 level floor (CA3). The stored water will be released or discharged during and following the storm event at a controlled rate from each catchment area such that the total release rate is less than or equal to the maximum allowable release rate from the combined controlled areas.

Storm water runoff from the roof CA1 (west roof) will be controlled by ten (10) roof drains fitted with weirs for flow control. The roof drains will be WATTS Large area single slot roof drains with adjustable flow control (RD-100-A1). The weir opening will be adjusted to the three-quarters open setting.

Storm water runoff from the roof CA2 (east roof) will be controlled by ten (10) roof drains fitted with weirs for flow control. The roof drains will be WATTS Large area single slot roof drains with adjustable flow control (RD-100-A1). The weir opening will be adjusted to the fully open setting.

Stormwater runoff from CA3, which is comprised of the surface level parking area and adjacent landscaped area between the surface parking and the building, will be controlled by a cistern pumping system within the underground storage tanks placed under the driving surface of parking level P2. The discharge rate of the pump will be limited to ensure that the total allowable release rate does not exceed. There will be no ground surface storage on the site.



The roof drain weir opening settings and the cistern pump settings have been selected to ensure that the total allowable combined controlled area release rate is not exceeded while ensuring that the available storage capacity on each roof and below grade is also not exceeded. Calculations for available rooftop storage and underground storage tanks are summarized in Appendix A. Roof drain specifications are provided in Appendix B.

The following tables present a summary of the controlled and uncontrolled runoff for each catchment and the required storage resulting from the restriction in flow rate.

Table 2-3 – Summary of Runoff Rates and Storage

Catchment Area ID.	Outlet Location	100-year design Storm			
		Release Rate (L/s)	Required Storage Volume (m ³)	Required Storage depth (m)	Available Storage (m ³)
UA1	Carling Avenue	40.6	N/A	N/A	N/A
CA1 (west roof)	Storm sewer	15.4	35.2	0.15	35.83
CA2 (east roof)	Storm Sewer	16.8	30.5	0.15	30.64
CA3 (parking lot)	Storm Sewer	10.0	36.5	1.11	42.8
Total Storm Runoff Rate		82.8			

The total allowable runoff rate from the site was 89.3 L/s. The total actual runoff rate during a 100 year design storm event is 82.8 L/s which is less than the total allowable runoff rate. Refer to Appendix A for a detailed summary of the stormwater management.

2.3.11 Rooftop Storage

Rooftop storage will be provided in CA1 (west roof), and CA2 (east roof).

The storage on the upper roof, CA1, will consist of 10 sections each containing an outlet drain as previously discussed. The remaining roof area will be divided into ten sections. The roof drainage plans obtained from the Architect have been included in Appendix B. The divide between each of the quadrants has been set at 0.1 m high relative to the drain. When the water is less than 0.10m high relative to the drain, water will be confined within each of the ten quadrants. Water levels in excess of 0.1m will result in overflow of the separation between the quadrants and the stored water will be able to drain through any of the quadrants should one or more drains become inoperable. Additionally the roof will be fitted with overflow scuppers located at 0.15m relative to the drains. In the event that ponding occurs during a storm event which significantly exceeds the required storage during a 100 year storm event, or if some or all drains become plugged water can outlet from the roof and will land on the uncontrolled area below and ultimately deposit into the storm drains located on the adjacent street. The roof top



storage has been designed to prevent standing water from pooling and is designed with a slope of 1.5%.

The storage on the east roof, CA2, will consist of ten similar sections, each with an outlet drain as previously discussed. The east roof will have a minimum slope of 1.5%. The separation between the ten sections will overflow above an elevation of 0.09m relative to the elevation of the drains. The roof will be fitted with overflow scuppers at 0.15m relative to the drains at the perimeter of the building.

Routing of the internal storm pipe directing water from the roofs to the storm lateral is the responsibility of the mechanical engineer.

2.3.12 Underground Storage

The surface runoff from the parking area is to be captured and conveyed by trench drains into maintenance hole CBMH-MH2 and catch basins CB1, CB2, and CB3. The surface runoff from the landscaped area south of the surface parking is to be captured by shallow swales that will convey the runoff to rear-yard catch basins. These maintenance holes, catch basins and rear yard catch basins will discharge to underground precast concrete storage tanks located under the driving surface of parking level P2 along the easternmost drive isle of the underground parking garage. The soft landscaping area to the south of the proposed surface parking area is to be drained by shallow swales into RYCB, which directly connect to the above mentioned CBMH's and STM'MH's.

Since the native soils at the site consist of highly plastic silty clay, there will be no significant infiltration from the tanks to the surrounding soils. Additionally, the concrete tanks are to be sealed. For this reason, the proposed stormwater tanks have been designed as storage tanks only and not infiltration tanks. Therefore, the potential of an elevated groundwater level has no significant impact on the design of the proposed storage tanks.

The underground storage will consist of three Boyd Bros 12,265L Low bow septic tanks. The three storage tanks are to be connected in series, and outlet into a 6000L Boyd Bros precast concrete tank. A discharge pump is to be installed in the second compartment of the 6000L tank with a forcemain, which is to connect to the storm sewer outlet from the building along the easternmost side of the parking garage. The pump and forcemain size is to be determined by the mechanical engineer. The developer / sewer contractor may propose the use of an alternative equivalent product. Shop drawings should be submitted to the design engineer prior to acceptance of equivalency. Shop drawings should be submitted, of the Boyd Bros Concrete Tanks or accepted equivalent system, to the design engineer for approval prior to installation. The first tank will accept stormwater from the above mentioned storm sewer, located along the south of the site in the surface parking and subsequent landscaped area from the outlet of storm maintenance hole STM-MH1. The three tanks are to be connected by a 300mm diameter pipe at 0% slope to promote equal drainage of the three tanks into the pump chamber.



The City of Ottawa Sewer design guideline indicates that an assumed constant flow rate during a storm event underestimates the required storage during a storm event. The discharge rate will ultimately be determined by the mechanical engineer. The discharge rate is to be a 10 L/s plus or minus 2.0L/s. The storage tanks have a design capacity greater than the storage requirements for a 100-year storm. In addition to the storage provided in the storage tanks, there is additional storage capacity in the 6000L precast concrete tank to facilitate additional stormwater in the event that a storm event exceeds the 100-year event. The force main is to tie into storm outlet for the roof drains along the eastern portion of the proposed development

As previously indicated, the underground tanks are comprised of Boyd Bros Precast Concrete Tanks. Each tank has dimensions of 6.05m long by 2.59m wide with a working capacity of 12,260L. The pump chamber has dimensions of 3.06m long by 2.03m wide with a working capacity of 6,000L. Given the depth of the tank, it is anticipated that the tanks will still be within the silty clay layer at the bottom of the excavation for the tanks. It is proposed that the 150mm of sand is brought into the bottom of the excavation for leveling purposes. Once the tanks are placed, backfill consisting of Granular B is to be placed around the tanks and a 200mm thick layer on top of the tanks prior to pouring the slab of the parking surface.

2.4 Stormwater Quality Control

As previously indicated in the report, Kollaard Associates has reached out to Rideau Valley Conservation Authority to obtain the quality control design criteria for the site. At time this report was prepared, no criteria has been provided. Since the discharge from the site is being directed into an existing storm sewer system it has been assumed that there will be no quality control design control requirements for the site. Best management practices will be incorporated where possible to reduce the potential transport of pollutants from the site to the storm sewer system.

The major source of stormwater contamination from a site, once development is completed and vegetation is established in the landscaped areas, is the onsite surface parking and roadways.

The surface areas at the site consist of the roof of the building, the landscaped areas, visitor parking area and the walkway and terrace areas.

- Surface parking will be limited to sixteen spaces which will be located at the rear of the buildings. Runoff from this parking will be directed to underground storage tanks and controlled.
- The roof of the building is not considered to be a major source of suspended solids contamination.
- The runoff from surface area of the below grade parking area driveway is limited to a short section not covered by the building. The remainder of the driveway is covered and not subject to precipitation. Snow melt from the vehicles within the parking garage will be directed to the sanitary sewer.



- The landscaped areas are not considered to be a source of suspended solids as the landscaped areas provides vegetative filtration of the surface runoff and the vegetation and landscaping protect the ground surface reducing the potential for erosion and eliminating the landscaped ground surface area as a source of suspended solids.
- The walkways are limited in area and will be graded to direct runoff to vegetated surfaces where possible.
- The use of best management practices for the application of salt, sand and other snow and ice removal products can reduce the potential pollution from the walkways.

2.5 Stormwater System Operation and Maintenance

2.5.1 Roof Drains

The Roof Drains should be inspected on a semi-annual basis and following major storm events. Any blockages, trash or debris should be removed. The Roof Drains should be inspected before winter to ensure they have not been clogged with leaves.

2.5.2 Catch basin / Manhole

The catch basins and manholes should be cleaned with a hydrovac excavation truck following completion of construction, paving of the asphaltic concrete surface and establishment of adequate grass cover on the landscaped areas.

Following the initial cleaning the catch basins and manholes should be inspected on a semi-annual basis and following major storm events. Any blockages, trash or debris should be removed. Once the sediment accumulation in the catch basins and manhole has reached a level equal to 0.15 metres below the outlet invert of the structure, the sediment should be removed by hydro excavation.

2.5.3 Stormwater Storage Tanks

Detailed installation, guidelines are to be provided by the precast concrete tank manufacturer prior to construction. In general maintenance procedures consist of Inspection and cleaning as follows:

Inspection:

- Inspect all observation ports, inflow and outflow connections, and the discharge area.
- Identify and log any sediment and debris accumulation, system backup, or discharge rate changes.
- If there is a sufficient need for cleanout, contact a local cleaning company for assistance.

Cleaning:

- If a pre-treatment device is installed, follow manufacturer recommendations.
- Using a vacuum pump truck, evacuate debris from the inflow and outflow points.



- Flush the system with clean water, forcing debris from the system.
- Repeat steps 2 and 3 until no debris is evident.

2.5.4 Inspections

The owner or designated Property Management Company is responsible for inspections and maintenance. Records of inspections and maintenance should be kept for each visit. The suggested inspection schedule should be followed until the records indicate a more appropriate site specific schedule.

3 STORM SEWER DESIGN AND SUFFICIENCY OF EXISTING MUNICIPAL STORM SEWER

3.1 Storm Sewer Design

The on-site storm sewers were designed to be in general conformance with the City of Ottawa Sewer Design Guidelines (October 2012 as amended). Specifically, storm sewers were sized using Manning's Equation, assuming a roughness coefficient $N = 0.013$, to accommodate the uncontrolled runoff from the 5-year storm, under 'open-channel' conditions. There are two storm sewer laterals. The first storm sewer lateral is located on the west side of the proposed development for the purposes of the weeping tile drain pump. The other lateral is intended to convey the runoff collected on the building roofs and from the underground storage tanks to the storm sewer along Carling Avenue. The proposed storm sewer lateral conveying the roof runoff and storage tank discharge will have a diameter of 300 mm and a slope of 1.3 percent. From the sewer design calculations included in Appendix A, the minimum capacity of the 300 mm lateral is 110.4 L/sec. The unrestricted storm demand on this lateral during a 5-year design storm with a time of concentration of 10 minutes is 68.0 L/sec for the roof runoff, and 30.2 L/sec for the surface parking and adjacent landscaping (total unrestricted flow 98.3 L/s) resulting in a Q/Q_{full} ratio during a 5 year storm event of 0.89. The restricted flow rate for the controlled areas is a total of 42.20 L/sec, which is less than the 110.4L/sec capacity of the 300mm lateral.

As such, the proposed laterals will be sufficient to meet the storm demand under 'open channel flow' conditions.

3.2 Existing Storm Sewer

The proposed storm lateral from the site will be connected to the existing 600 mm diameter concrete storm sewer along Carling Avenue. The existing storm sewer along the south side of Carling Avenue increases in size from 525 mm in diameter to 600 mm in diameter at storm manhole MHST52076 about 50 mm west of the site and then increases in diameter to 675 mm at storm manhole MHST52081 approximately 42 metres east of the site. The slope of the 525 mm storm sewer west of the site is about 0.15 percent resulting in a capacity of 166.73 L/s. The minimum slope of the 600 mm storm sewer is 0.2 percent resulting in a capacity of 274 L/s.



The existing 600 mm diameter storm sewer has been receiving runoff from the site having a pre-development runoff coefficient of $C=0.83$ for more than 30 years.

The pre-development conditions result in a peak runoff rate during a 5 year storm event of 148.2 L/s. Due to the design criteria, the peak runoff during a 5 year storm event during post-development conditions will be reduced to 52.6 L/s. The peak runoff during a 100 year event during post-development conditions will be reduced to 88.2 L/s. Since the post development runoff rate from the site will be significantly reduced from the pre-development conditions, it is considered that there will be sufficient capacity within the storm sewer main to accommodate the runoff from the site during post-development conditions.

4 EROSION AND SEDIMENT CONTROL

The owner (and/or contractor) agrees to prepare and implement an erosion and sediment control plan at least equal to the stated minimum requirements and to the satisfaction of the City of Ottawa, appropriate to the site conditions, prior to undertaking any site alterations (filling, grading, removal of vegetation, etc.) and during all phases of site preparation and construction in accordance with the current best management practices for erosion and sediment control. It is considered to be the owners and/or contractors responsibility to ensure that the erosion control measures are implemented and maintained.

In order to limit the amount of sediment carried in stormwater runoff from the site during construction, it is recommended to install a silt fence along the property, as shown in Kollaard Associates Inc. Drawing #220978-ER. The silt fence may be polypropylene, nylon, and polyester or ethylene yarn.

If a standard filter fabric is used, it must be backed by a wire fence supported on posts not over 2.0 m apart. Extra strength filter fabric may be used without a wire fence backing if posts are not over 1.0 m apart. Fabric joints should be lapped at least 150 mm (6") and stapled. The bottom edge of the filter fabric should be anchored in a 300 mm (1 ft) deep trench, to prevent flow under the fence. Sections of fence should be cleaned, if blocked with sediment and replaced if torn.

Filter socks should be installed across existing storm manhole and catch basin lids. As well, filter socks should be installed across the proposed catch basin and manhole lids immediately after the structures are placed. The filter socks should only be removed once the asphaltic concrete is installed and the site is cleaned.

A sediment trap should be installed in each maintenance hole receiving discharge from the trench drains. The sediment trap should be below the inlet pipe from the trench drain. The sediment traps should be inspected regularly and cleaned/emptied as required. The sediment traps should only be removed once construction is completed.

The proposed landscaping works should be completed as soon as possible. The proposed granular and asphaltic concrete surfaced areas should be surfaced as soon as possible.



The silt fences should only be removed once the site is stabilized and landscaping is completed. These measures will reduce the amount of sediment carried from the site during storm events that may occur during construction.

5 CONCLUSIONS

This report addresses the adequacy of the existing municipal storm sewer to service the proposed development of the residential apartment buildings at 3430 Carling Avenue. Based on the analysis provided in this report, the conclusions are as follows:

SWM for the proposed development will be achieved by restricting the 100 year post development flow to the 5 year pre-development flow assuming a predevelopment runoff coefficient of 0.5.

The existing municipal storm sewers will have adequate capacity to convey the runoff from the development during post-development conditions.

During all construction activities, erosion and sedimentation shall be controlled.

We trust that this report provides sufficient information for your present purposes. If you have any questions concerning this report or if we can be of any further assistance to you on this project, please do not hesitate to contact our office.

Sincerely,
Kollaard Associates Inc.

Prepared by:

Reviewed by:



Nick Recoskie, EIT

Steve deWit, P.Eng.



Appendix A: Storm Design Information

- Sheet 1 - Pre Development Runoff Rate, Allowable Release Rate and STM Summary
- Sheet 2 - Post-Development Runoff Rate - Uncontrolled Area
- Sheet 3 - Actual Discharge Rate and Storage Volume Requirements CA-1 (West Roof)
- Sheet 4 - Storage Volume & Discharge Rate Design Sheet - CA-1 (West Roof)
- Sheet 5 - Discharge Storage Curve CA-1 (West Roof)
- Sheet 6 - Stage Storage Curve CA-1 (West Roof)
- Sheet 7 - Actual Discharge Rate and Storage Volume Requirements CA-2 (East Roof)
- Sheet 8 - Storage Volume & Discharge Rate Design Sheet - CA-2 (East Roof)
- Sheet 9 - Discharge Storage Curve CA-2 (East Roof)
- Sheet 10 - Stage Storage Curve CA-2 (East Roof)
- Sheet 11 – Actual Discharge Rate and Storage Volume Requirements CA-3 (Parking Area)
- Sheet 12 – Outlet Control Design Sheet CA-3 (Underground Storage)
- Sheet 13 - Discharge Storage Curve CA-3 (Underground Storage)
- Sheet 14 - Stage Storage Curve CA-3 (Underground Storage)
- Sheet 15- Sewer Design Sheet – Storm Sewer laterals

APPENDIX A: STORMWATER MANAGEMENT MODEL
PRE-DEVELOPMENT RUNOFF RATE, ALLOWABLE RELEASE RATE AND SWM SUMMARY

Client: Rohit Communities Ontario Inc.
 Job No.: 220978
 Location: 3430 Carling Avenue
 Date: March 28, 2022

Sheet 1

PRE DEVELOPMENT FLOW

Runoff Coefficient Equation

$$C = (A_{\text{hard}} \times 0.9 + A_{\text{soft}} \times 0.2 + A_{\text{gravel}} \times 0.6) / A_{\text{tot}}$$

Area	Surface	Ha	"C"	C _{avg}
Total	Gravel	0.000	0.60	0.83
0.6163	Roof/Asphalt/Concrete	0.556	0.90	
	Patio Stones	0.000	0.70	
	Grass	0.060	0.20	

5 Year Event			
Pre Dev.	C	Intensity	Area
5 Year	0.83	104.19	0.616
2.78CIA= 148.16			
148.2 L/s			

**Use a 10 minute time of concentration for 5 year

5 Year Event			
Pre Dev.	C	Intensity	Area
5 Year	0.50	104.19	0.616
2.78CIA= 89.25			
89.3 L/s			

**Use a 10 minute time of concentration for 5 year

Total Allowable Release: **89.3 L/s**

STORMWATER MANAGEMENT SUMMARY

Sub Area I.D.	Sub Area (ha)	5 year C	100 year 'C'	Outlet Location	5 Year Flow Rate (L/s)	Required 5 year Storage (m ³)	100 Year Flow Rate (L/s)	Required 100 year Storage (m ³)	100 year Storage Depth (m)
Total Allowable Runoff Rate from Site									
	0.62				89.3		89.3		
Post-Development Uncontrolled Runoff Rate from Site									
UA1	0.18	0.39	0.46	Storm	20.4	NA	41.3	NA	
Post-Development Controlled Release Rate from Site									
CA1 (WEST ROOF)	0.134	0.90	1.00	Storm	11.0	12.5	15.4	35.5	0.15
CA2 (EAST ROOF)	0.127	0.90	1.00	Storm	11.4	13.5	16.8	30.6	0.15
CA3 (PARKING LOT)	0.174	0.60	0.68	Storm	10.0	12.4	10.0	35.6	1.11
Total Runoff Rate from Site									
	0.616				52.8		83.5		

APPENDIX A: STORMWATER MANAGEMENT MODEL
POST-DEVELOPMENT RUNOFF RATE - UNCONTROLLED AREA

Client: Rohit Communities Ontario Inc.
Job No.: 220978
Location: 3430 Carling Avenue
Date: March 28, 2023

Sheet 2

UA1 - UNCONTROLLED AREA

Post Dev run-off Coefficient "C"

Area	Surface	Ha	5 Year Event		100 Year Event	
			"C"	C _{avg}	"C"	C _{avg}
Total	Gravel	0.000	0.60	0.39	0.75	0.46
0.181	Asphalt/ Concrete	0.033	0.90		1.00	
	Patio Stones	0.020	0.70		0.88	
	Grass	0.127	0.20		0.25	

Runoff Coefficient Equation
 $C = (A_{\text{hard}} \times 0.9 + A_{\text{soft}} \times 0.2) / A_{\text{tot}}$

Post Dev Free Flow

5 Year Event

Pre Dev.	C	Intensity	Area
5 Year	0.39	104.19	0.181
2.78CIA= 20.45			
20.4 L/S			

**Use a 10 minute time of concentration for 5 year

100 Year Event

Pre Dev.	C*	Intensity	Area
100 Year	0.46	178.56	0.181
2.78CIA= 41.33			
41.3 L/S			

**Use a 10 minute time of concentration for 100 year

*C value multiplied by 1.25 for 100 year event

Equations:

Flow Equation

$Q = 2.78 \times C \times I \times A$

Where:

C is the runoff coefficient

I is the intensity of rainfall, City of Ottawa IDF

A is the total drainage area

APPENDIX A: STORMWATER MANAGEMENT MODEL
ACTUAL DISCHARGE RATE AND STORAGE VOLUME REQUIREMENTS
CA-1 West Roof

Client: Rohit Communities Ontario Inc.
 Job No.: 220978
 Location: 3430 Carling Avenue
 Date: March 28, 2022

Sheet 3

(CA1)			5 Year Event		100 Year Event	
Area ha	Surface	Ha	"C"	C _{avg}	"C"	C _{avg}
0.134	Asphalt/ Concrete/Roof	0.134	0.90	0.90	1.00	1.00
	Gravel	0.000	0.60		0.75	
	Patio Stone/Semipermeable block	0.000	0.70		0.88	
	Grass	0.000	0.20		0.25	

Storage Requirements for West Roof Area (CA1)

Area = 0.134 hectares
 5-year Runoff Coefficient = 0.90 post development
 100-year Runoff Coefficient = 1.00 post development

Release Rate L/s				2	5	8	11	14	17	20
Return Period	Time (min)	Intensity (mm/hr)	Flow Q (L/s)	Storage Required (m ³)						
5 Year	10	104.19	34.98	19.8	18.0	16.2	14.4	12.6	10.8	9.0
	20	70.25	23.59	25.9	22.3	18.7	15.1	11.5	7.9	4.3
	30	53.93	18.11	29.0	23.6	18.2	12.8	7.4	2.0	-3.4
	40	44.18	14.84	30.8	23.6	16.4	9.2	2.0	-5.2	-12.4
	50	37.65	12.64	31.9	22.9	13.9	4.9	-4.1	-13.1	-22.1
	60	32.94	11.06	32.6	21.8	11.0	0.2	-10.6	-21.4	-32.2
	70	29.37	9.86	33.0	20.4	7.8	-4.8	-17.4	-30.0	-42.6
Maximum 5 year storage rate				33.0	23.6	18.7	15.1	12.6	10.8	9.0
Release Rate L/s				2	5	8	11	14	17	20
100 Year	10	178.56	66.62	38.8	37.0	35.2	33.4	31.6	29.8	28.0
	20	119.95	44.75	51.3	47.7	44.1	40.5	36.9	33.3	29.7
	30	91.87	34.27	58.1	52.7	47.3	41.9	36.5	31.1	25.7
	40	75.15	28.03	62.5	55.3	48.1	40.9	33.7	26.5	19.3
	50	63.95	23.86	65.6	56.6	47.6	38.6	29.6	20.6	11.6
	60	55.89	20.85	67.9	57.1	46.3	35.5	24.7	13.9	3.1
	70	49.79	18.58	69.6	57.0	44.4	31.8	19.2	6.6	-6.0
80	44.99	16.79	71.0	56.6	42.2	27.8	13.4	-1.0	-15.4	
Maximum 100 year storage rate				71.0	57.1	48.1	41.9	36.9	33.3	29.7

**APPENDIX A: STORMWATER MANAGEMENT MODEL
STORAGE VOLUME & DISCHARGE RATE DESIGN SHEET - CA-1**

Client: Rohit Communities Ontario Inc.
Job No.: 220978
Location: 3430 Carling Avenue
Date: March 28, 2023

Sheet 4

Storage Depth (m)	Layer Thickness (m)	Incremental Volume (upper roof) (m ³)	Cumulative Storage Volume (m ³)	Release Rate Per Drain (Fully Open) (L/sec)	Release Rate All Drains (L/sec)	Total Outflow (L/sec)
0.15	0.01	4.23	35.83	1.55	15.55	15.55
0.14	0.01	4.23	31.61	1.46	14.62	14.62
0.13	0.01	4.23	27.38	1.37	13.69	13.69
0.12	0.01	4.23	23.16	1.28	12.75	12.75
0.11	0.01	4.23	18.93	1.18	11.82	11.82
0.10	0.01	3.91	14.71	1.09	10.89	10.89
0.09	0.01	3.21	10.80	1.00	9.96	9.96
0.08	0.01	2.50	7.59	0.90	9.03	9.03
0.07	0.01	1.88	5.08	0.81	8.10	8.10
0.06	0.01	1.35	3.20	0.72	7.17	7.17
0.05	0.01	0.90	1.85	0.62	6.21	6.21
0.04	0.01	0.55	0.95	0.50	4.97	4.97
0.03	0.01	0.28	0.40	0.37	3.73	3.73
0.02	0.01	0.10	0.12	0.25	2.48	2.48
0.01	0.01	0.01	0.01	0.12	1.24	1.24
0.00	0.00	0.00	0.00	0.00	0.00	0.0

Roof Drain Type: Watts Accutrol Large Area Roof Drain RD-100-A1 - 3/4 OPEN
 Number of Drains: 10

APPENDIX A: STORMWATER MANAGEMENT MODEL STORAGE
Discharge -Storage Curve
CA-1 West Roof

Sheet 5

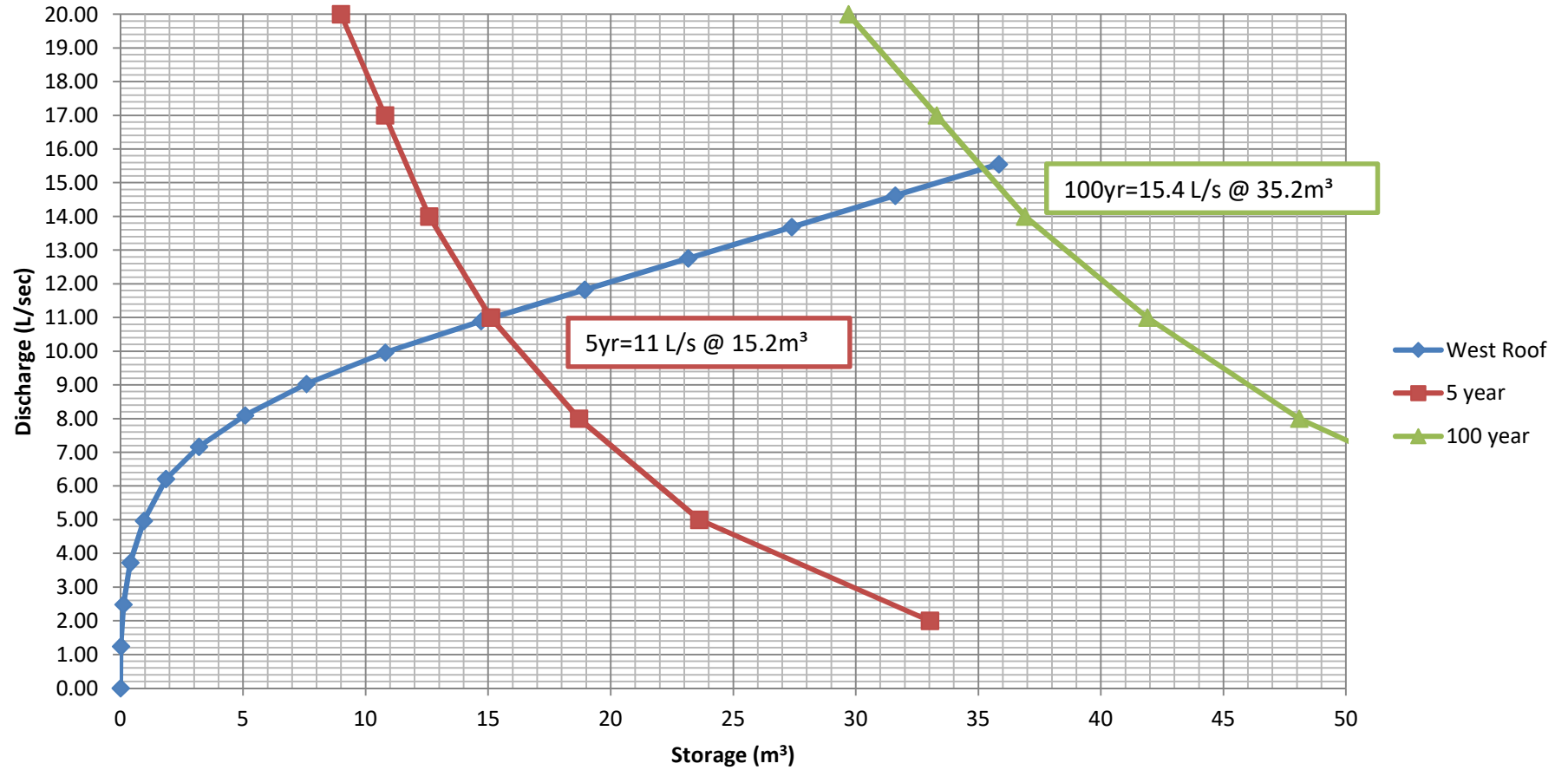

APPENDIX A: STORMWATER MANAGEMENT MODEL
Stage-Storage Curve
CA-1 West Roof

Sheet 6

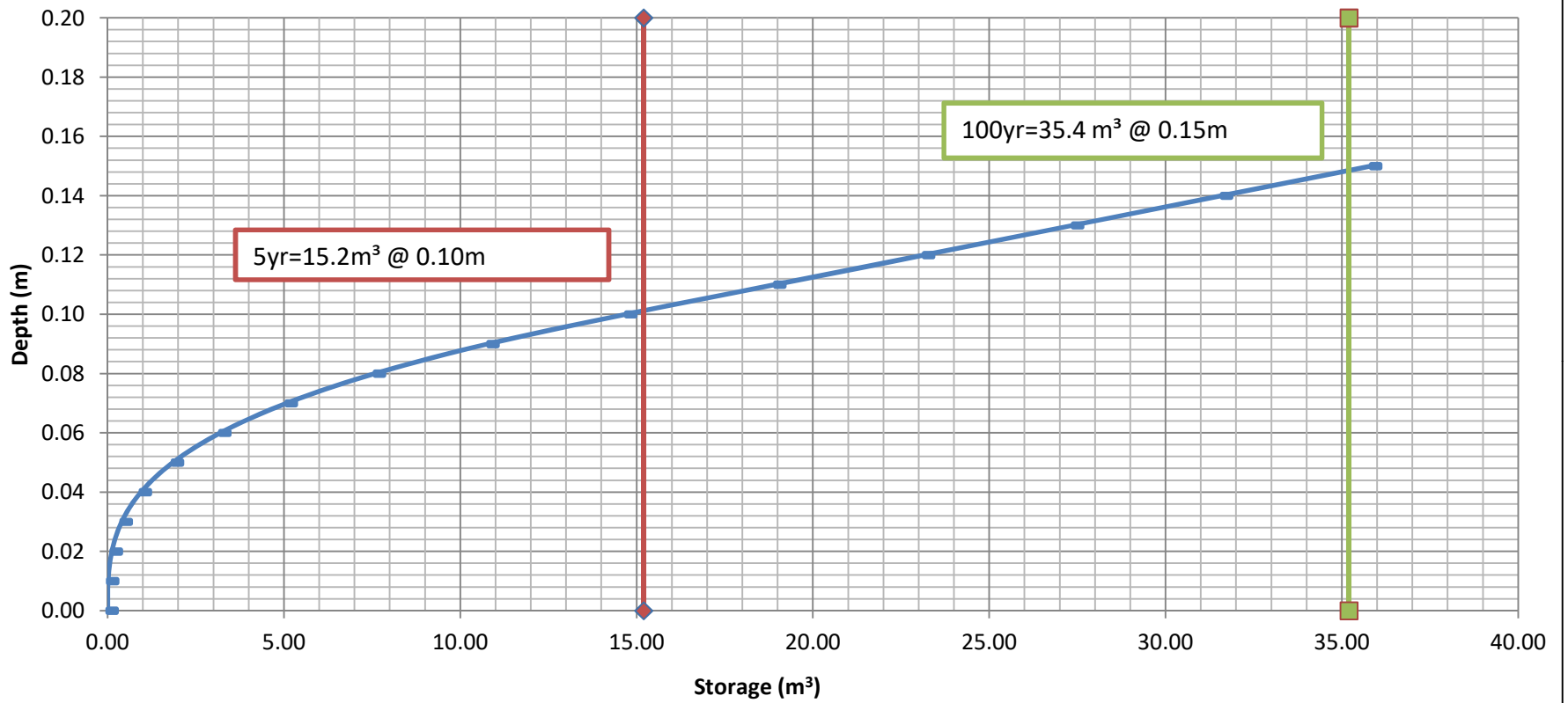

APPENDIX A: STORMWATER MANAGEMENT MODEL
ACTUAL DISCHARGE RATE AND STORAGE VOLUME REQUIREMENTS
 CA-2 East Roof

Client: Rohit Communities Ontario Inc.
 Job No.: 220978
 Location: 3430 Carling Avenue
 Date: March 28, 2022

Sheet 7

(CA2)			5 Year Event		100 Year Event	
Area ha	Surface	Ha	"C"	C _{avg}	"C"	C _{avg}
0.127	Asphalt/ Concrete/Roof	0.127	0.90	0.90	1.00	1.00
	Gravel	0.000	0.60		0.75	
	Patio Stone/Semipermeable block	0.000	0.70		0.88	
	Grass	0.000	0.20		0.25	

Storage Requirements for Roof Area (CA2)

Area = 0.127 hectares
 5-year Runoff Coefficient = 0.90 post development
 100-year Runoff Coefficient = 1.00 post development

Release Rate L/s				2	5	8	11	14	17	20
Return Period	Time (min)	Intensity (mm/hr)	Flow Q (L/s)	Storage Required (m ³)						
5 Year	10	104.19	33.11	18.7	16.9	15.1	13.3	11.5	9.7	7.9
	20	70.25	22.32	24.4	20.8	17.2	13.6	10.0	6.4	2.8
	30	53.93	17.14	27.2	21.8	16.4	11.0	5.6	0.2	-5.2
	40	44.18	14.04	28.9	21.7	14.5	7.3	0.1	-7.1	-14.3
	50	37.65	11.96	29.9	20.9	11.9	2.9	-6.1	-15.1	-24.1
	60	32.94	10.47	30.5	19.7	8.9	-1.9	-12.7	-23.5	-34.3
	70	29.37	9.33	30.8	18.2	5.6	-7.0	-19.6	-32.2	-44.8
Maximum 5 year storage rate				30.8	21.8	17.2	13.6	11.5	9.7	7.9
Release Rate L/s				2	5	8	11	14	17	20
100 Year	10	178.56	63.04	36.6	34.8	33.0	31.2	29.4	27.6	25.8
	20	119.95	42.35	48.4	44.8	41.2	37.6	34.0	30.4	26.8
	30	91.87	32.43	54.8	49.4	44.0	38.6	33.2	27.8	22.4
	40	75.15	26.53	58.9	51.7	44.5	37.3	30.1	22.9	15.7
	50	63.95	22.58	61.7	52.7	43.7	34.7	25.7	16.7	7.7
	60	55.89	19.73	63.8	53.0	42.2	31.4	20.6	9.8	-1.0
	70	49.79	17.58	65.4	52.8	40.2	27.6	15.0	2.4	-10.2
80	44.99	15.88	66.6	52.2	37.8	23.4	9.0	-5.4	-19.8	
Maximum 100 year storage rate				66.6	53.0	44.5	38.6	34.0	30.4	26.8

**APPENDIX A: STORMWATER MANAGEMENT MODEL
STORAGE VOLUME & DISCHARGE RATE DESIGN SHEET - CA-2**

Client: Rohit Communities Ontario Inc.
Job No.: 220978
Location: 3430 Carling Avenue
Date: March 28, 2022

Sheet 8

Storage Provided for East Roof Area (CA2)

Storage Depth (m)	Layer Thickness (m)	Incremental Volume (Lower Roof) (m ³)	Cumulative Storage Volume (m ³)	Release Rate Per Drain (Fully Open) (L/sec)	Release Rate All Drains (L/sec)	Total Outflow (L/sec)
0.15	0.01	3.51	30.64	1.86	16.77	16.77
0.14	0.01	3.51	27.13	1.74	15.65	15.65
0.13	0.01	3.51	23.62	1.61	14.53	14.53
0.12	0.01	3.51	20.11	1.49	13.41	13.41
0.11	0.01	3.51	16.60	1.37	12.30	12.30
0.10	0.01	3.37	13.09	1.24	11.18	11.18
0.09	0.01	2.89	9.72	1.12	10.06	10.06
0.08	0.01	2.25	6.83	0.99	8.94	8.94
0.07	0.01	1.69	4.57	0.87	7.82	7.82
0.06	0.01	1.21	2.88	0.75	6.71	6.71
0.05	0.01	0.81	1.67	0.62	5.59	5.59
0.04	0.01	0.49	0.85	0.50	4.47	4.47
0.03	0.01	0.25	0.36	0.37	3.35	3.35
0.02	0.01	0.09	0.11	0.25	2.24	2.24
0.01	0.01	0.01	0.01	0.12	1.12	1.12
0.00	0.00	0.00	0.00	0.00	0.00	0.00

Roof Drain Type: Watts Accutrol Large Area Roof Drain RD-100-A1 - FULLY OPEN
 Number of Drains: 10

APPENDIX A: STORMWATER MANAGEMENT MODEL STORAGE

**Discharge -Storage Curve
CA-2 East Roof**

Sheet 9

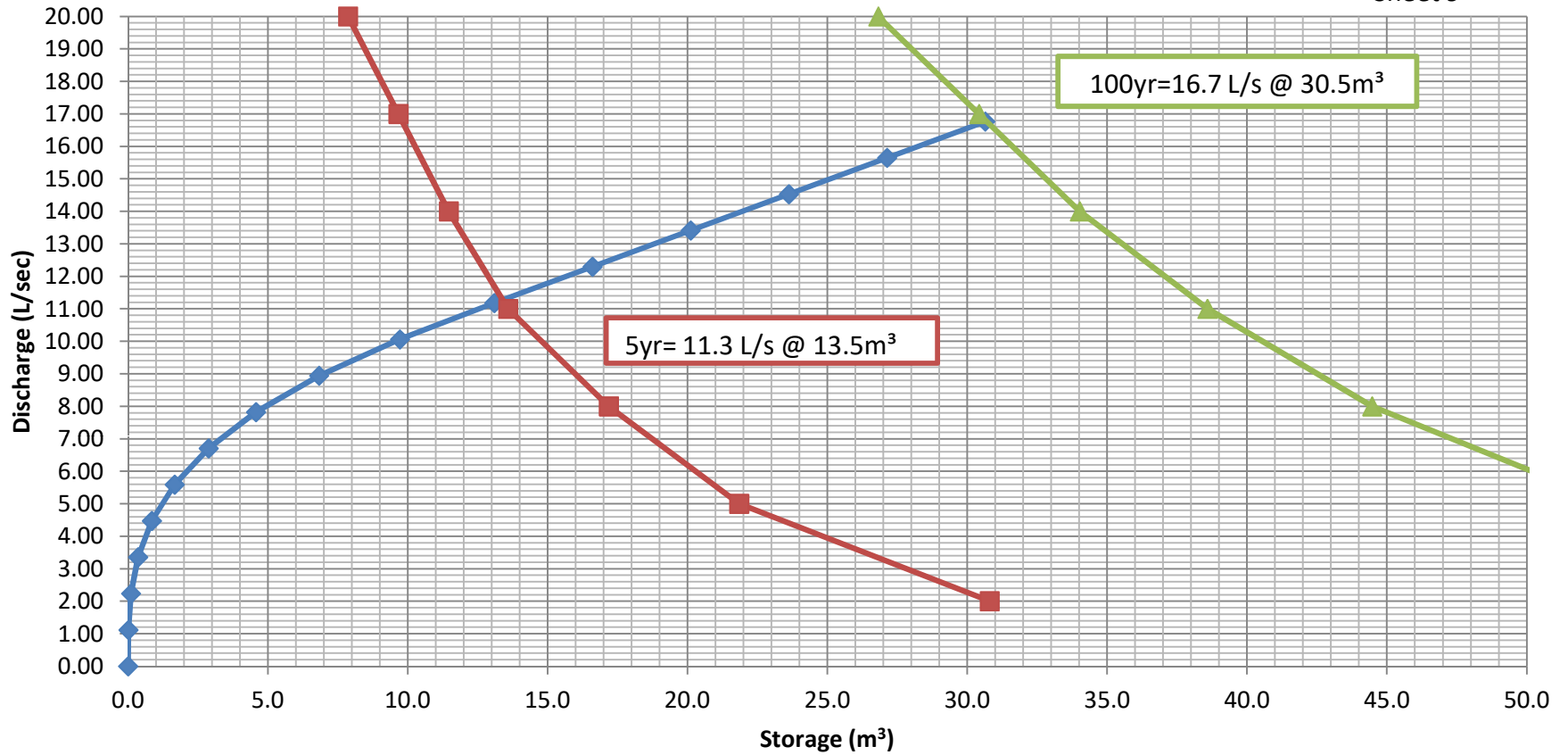

APPENDIX A: STORMWATER MANAGEMENT MODEL
Stage-Storage Curve
CA-2 East Roof

Sheet 10

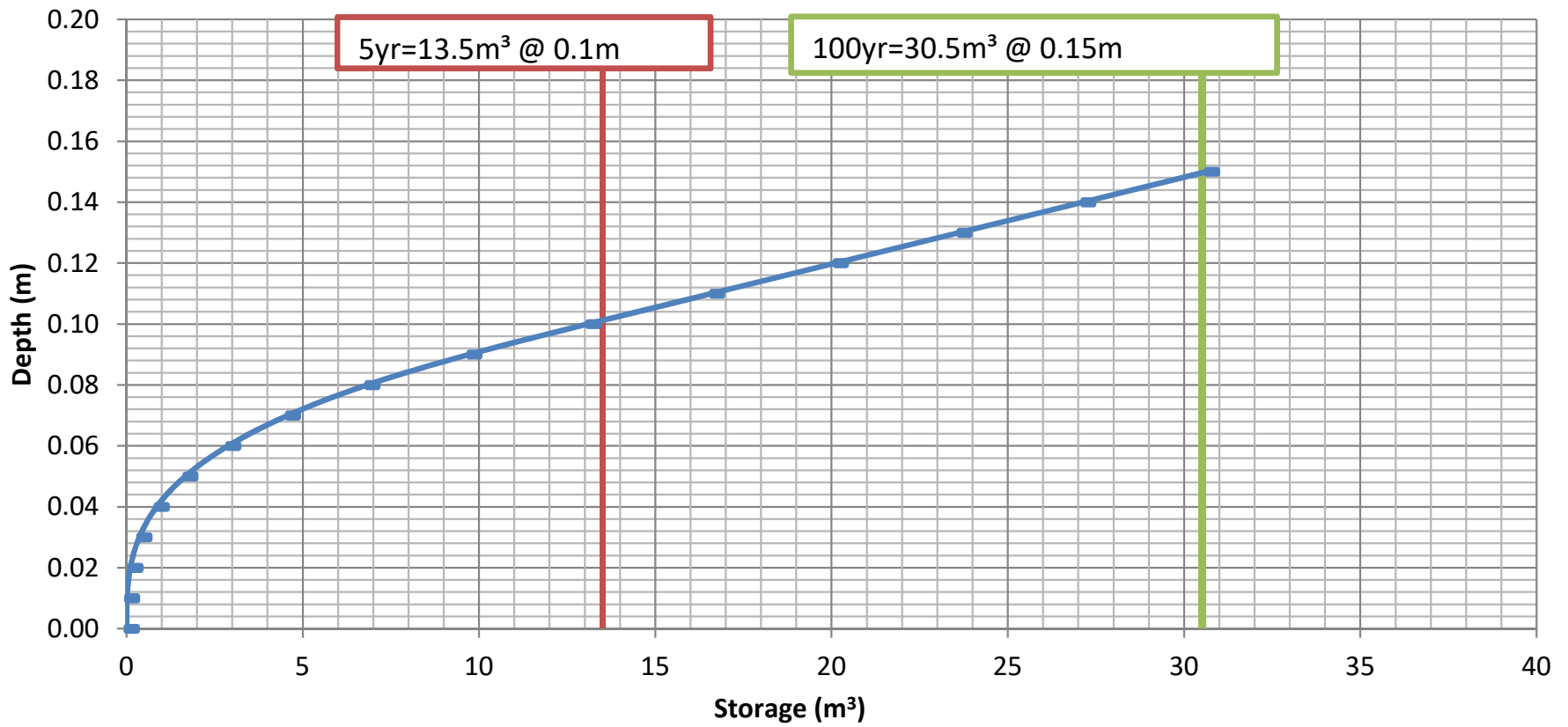

APPENDIX A: STORMWATER MANAGEMENT MODEL
ACTUAL DISCHARGE RATE AND STORAGE VOLUME REQUIREMENTS - CA3 (Parking Area)

Client: **Rohit Group**
 Job No.: **220978**
 Location: **3430 Carling Avenue**
 Date: **March 28, 2022**

Controlled Area			5 Year Event		100 Year Event	
Area ha	Surface	Ha	"C"	C _{avg}	"C" 10	C _{avg}
0.1741	Parking Area	0.0902	0.90	0.60	1.00	0.68
	Walkway	0.0126	0.70		0.88	
	Building Roof	0.0000	0.90		1.00	
	Landscape	0.0713	0.20		0.25	

Impervious Area Ratio 0.59

Storage Requirements for Controlled Areas

Area = **0.1741** hectares
 5-year Runoff Coefficient = **0.60** post development
 100-year Runoff Coefficient = **0.68** post development
 Duration Interval (min) = 10
 Release Rate Start (L/s) = 2
 Release Rate Interval (L/s) = 3

Return Period	Time (min)	Intensity (mm/hr)	Flow Q (L/s)	Release Rate L/s													
				2	5	8	11	14	17	20	23	26	29	32	35	38	
5 Year	5	141.18	40.99	11.7	10.8	9.9	9.0	8.1	7.2	6.3	5.4	4.5	3.6	2.7	1.8	0.9	
	15	83.56	24.26	20.0	17.3	14.6	11.9	9.2	6.5	3.8	1.1	-1.6	-4.3	-7.0	-9.7	-12.4	
	25	60.90	17.68	23.5	19.0	14.5	10.0	5.5	1.0	-3.5	-8.0	-12.5	-17.0	-21.5	-26.0	-30.5	
	35	48.52	14.09	25.4	19.1	12.8	6.5	0.2	-6.1	-12.4	-18.7	-25.0	-31.3	-37.6	-43.9	-50.2	
	45	40.63	11.80	26.4	18.3	10.2	2.1	-6.0	-14.1	-22.2	-30.3	-38.4	-46.5	-54.6	-62.7	-70.8	
	55	35.12	10.20	27.1	17.2	7.3	-2.6	-12.5	-22.4	-32.3	-42.2	-52.1	-62.0	-71.9	-81.8	-91.7	
	65	31.04	9.01	27.4	15.7	4.0	-7.7	-19.4	-31.1	-42.8	-54.5	-66.2	-77.9	-89.6	-101.3	-113.0	
	75	27.89	8.10	27.4	13.9	0.4	-13.1	-26.6	-40.1	-53.6	-67.1	-80.6	-94.1	-107.6	-121.1	-134.6	
	85	25.37	7.37	27.4	12.1	-3.2	-18.5	-33.8	-49.1	-64.4	-79.7	-95.0	-110.3	-125.6	-140.9	-156.2	
	95	23.31	6.77	27.2	10.1	-7.0	-24.1	-41.2	-58.3	-75.4	-92.5	-109.6	-126.7	-143.8	-160.9	-178.0	
	105	21.58	6.27	26.9	8.0	-10.9	-29.8	-48.7	-67.6	-86.5	-105.4	-124.3	-143.2	-162.1	-181.0	-199.9	
	115	20.12	5.84	26.5	5.8	-14.9	-35.6	-56.3	-77.0	-97.7	-118.4	-139.1	-159.8	-180.5	-201.2	-221.9	
	125	18.86	5.48	26.1	3.6	-18.9	-41.4	-63.9	-86.4	-108.9	-131.4	-153.9	-176.4	-198.9	-221.4	-243.9	
	135	17.76	5.16	25.6	1.3	-23.0	-47.3	-71.6	-95.9	-120.2	-144.5	-168.8	-193.1	-217.4	-241.7	-266.0	
	Maximum 5 year storage rate				27.4	19.1	14.6	11.9	9.2	7.2	6.3	5.4	4.5	3.6	2.7	1.8	0.9

Duration Interval (min) = 10
 Release Rate Start (L/s) = 2
 Release Rate Interval (L/s) = 3

Return Period	Time (min)	Intensity (mm/hr)	Flow Q (L/s)	Release Rate L/s													
				2	5	8	11	14	17	20	23	26	29	32	35	38	
100 Year	5	242.70	79.86	23.4	22.5	21.6	20.7	19.8	18.9	18.0	17.1	16.2	15.3	14.4	13.5	12.6	
	15	142.89	47.02	40.5	37.8	35.1	32.4	29.7	27.0	24.3	21.6	18.9	16.2	13.5	10.8	8.1	
	25	103.85	34.17	48.3	43.8	39.3	34.8	30.3	25.8	21.3	16.8	12.3	7.8	3.3	-1.2	-5.7	
	35	82.58	27.17	52.9	46.6	40.3	34.0	27.7	21.4	15.1	8.8	2.5	-3.8	-10.1	-16.4	-22.7	
	45	69.05	22.72	55.9	47.8	39.7	31.6	23.5	15.4	7.3	-0.8	-8.9	-17.0	-25.1	-33.2	-41.3	
	55	59.62	19.62	58.1	48.2	38.3	28.4	18.5	8.6	-1.3	-11.2	-21.1	-31.0	-40.9	-50.8	-60.7	
	65	52.65	17.32	59.8	48.1	36.4	24.7	13.0	1.3	-10.4	-22.1	-33.8	-45.5	-57.2	-68.9	-80.6	
	75	47.26	15.55	61.0	47.5	34.0	20.5	7.0	-6.5	-20.0	-33.5	-47.0	-60.5	-74.0	-87.5	-101.0	
	85	42.95	14.13	61.9	46.6	31.3	16.0	0.7	-14.6	-29.9	-45.2	-60.5	-75.8	-91.1	-106.4	-121.7	
	95	39.43	12.98	62.6	45.5	28.4	11.3	-5.8	-22.9	-40.0	-57.1	-74.2	-91.3	-108.4	-125.5	-142.6	
	105	36.50	12.01	63.1	44.2	25.3	6.4	-12.5	-31.4	-50.3	-69.2	-88.1	-107.0	-125.9	-144.8	-163.7	
	115	34.01	11.19	63.4	42.7	22.0	1.3	-19.4	-40.1	-60.8	-81.5	-102.2	-122.9	-143.6	-164.3	-185.0	
	125	31.86	10.48	63.6	41.1	18.6	-3.9	-26.4	-48.9	-71.4	-93.9	-116.4	-138.9	-161.4	-183.9	-206.4	
	135	30.00	9.87	63.7	39.4	15.1	-9.2	-33.5	-57.8	-82.1	-106.4	-130.7	-155.0	-179.3	-203.6	-227.9	
	145	28.36	9.33	63.8	37.7	11.6	-14.5	-40.6	-66.7	-92.8	-118.9	-145.0	-171.1	-197.2	-223.3	-249.4	
155	26.91	8.85	63.7	35.8	7.9	-20.0	-47.9	-75.8	-103.7	-131.6	-159.5	-187.4	-215.3	-243.2	-271.1		
165	25.61	8.43	63.6	33.9	4.2	-25.5	-55.2	-84.9	-114.6	-144.3	-174.0	-203.7	-233.4	-263.1	-292.8		
175	24.44	8.04	63.4	31.9	0.4	-31.1	-62.6	-94.1	-125.6	-157.1	-188.6	-220.1	-251.6	-283.1	-314.6		
Maximum 100 year storage rate				63.8	48.2	40.3	34.8	30.3	27.0	24.3	21.6	18.9	16.2	14.4	13.5	12.6	

APPENDIX A: STORMWATER MANAGEMENT MODEL
Stage-Storage Curve
CA-3 Underground Storage Tanks

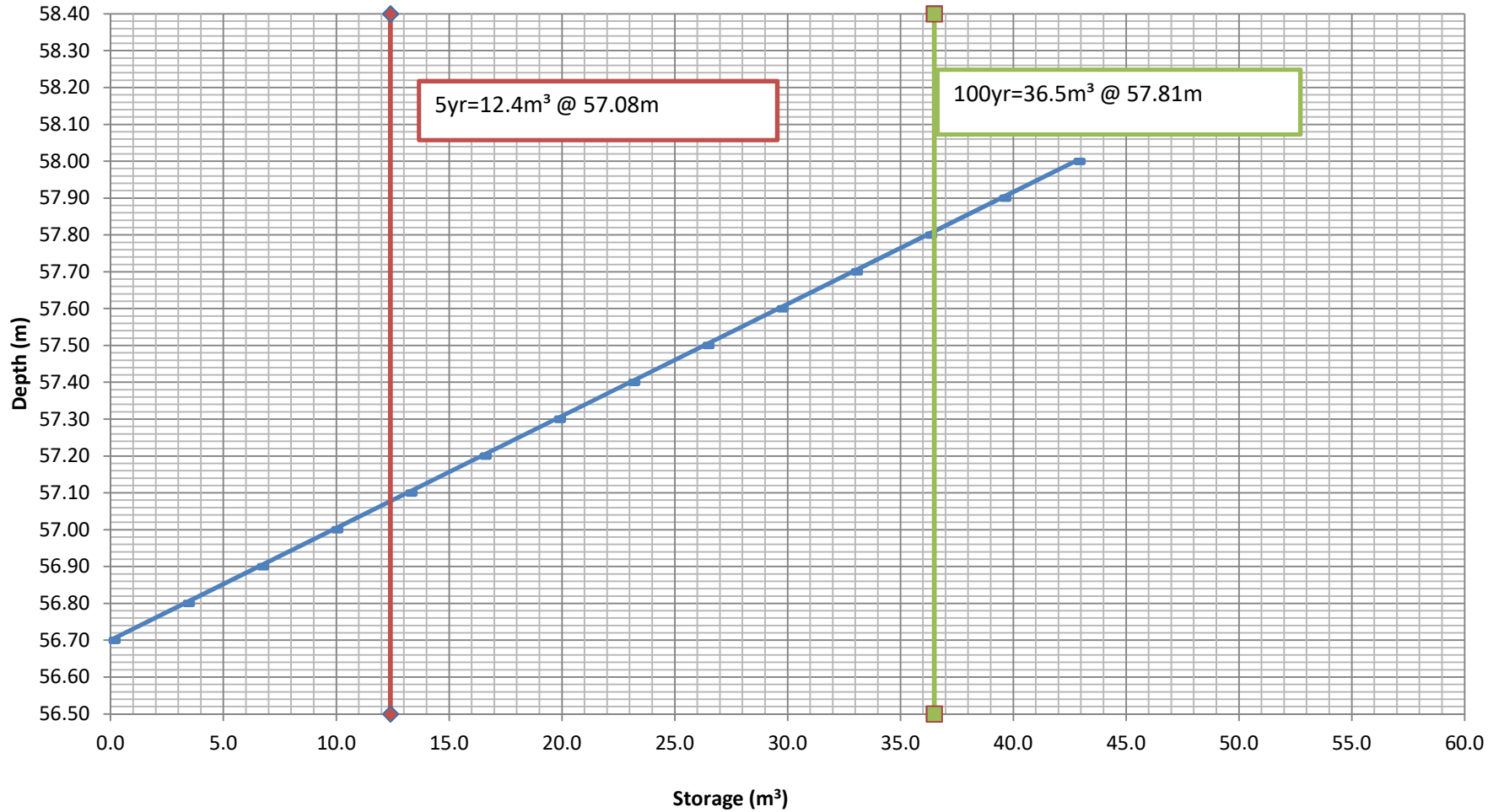

APPENDIX A: STORMWATER MANAGEMENT MODEL STORAGE

**Discharge -Storage Curve
CA-3 Underground Storage Tanks**

Sheet 14

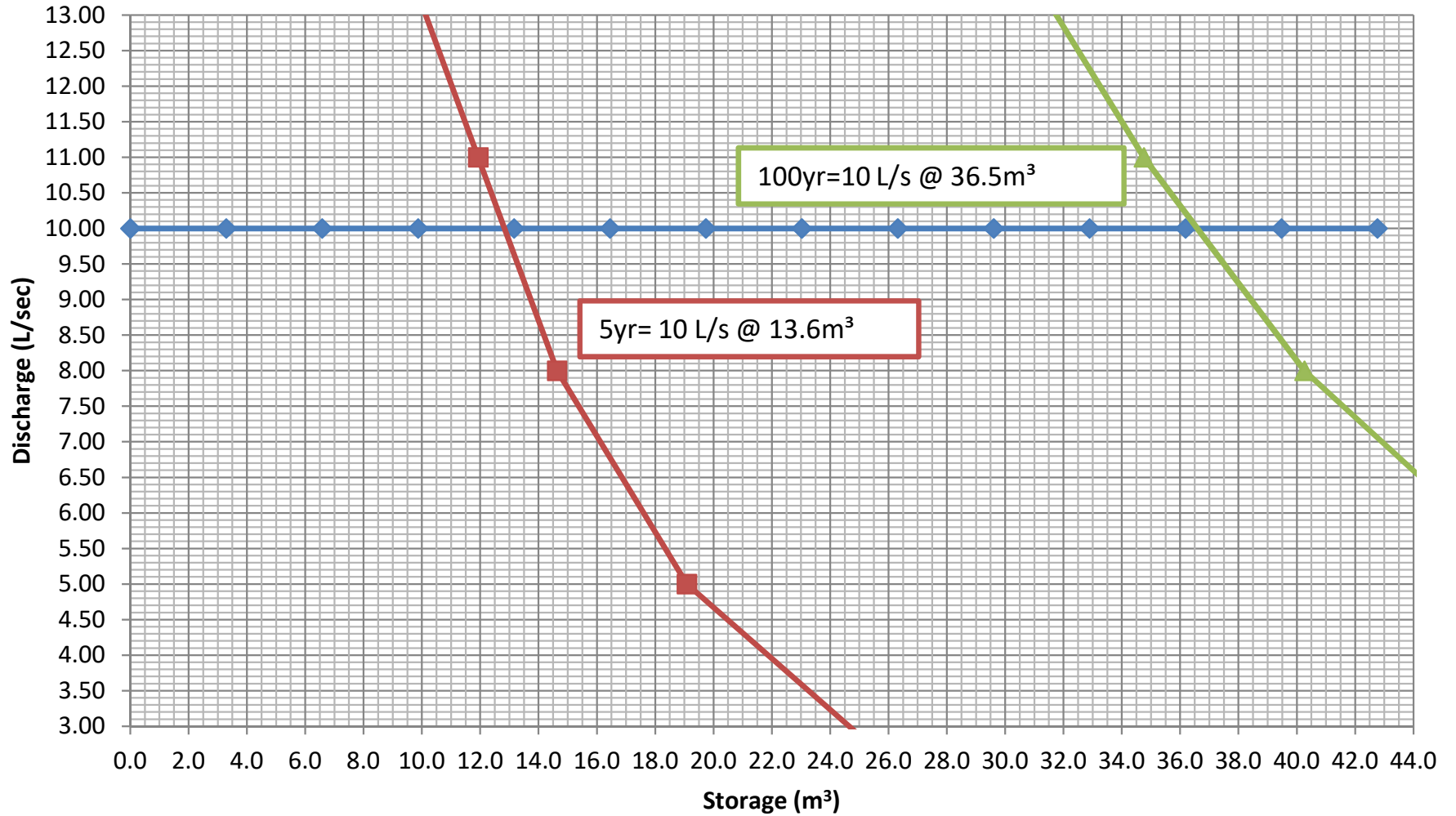

APPENDIX A: STORM SEWER DESIGN SHEET

Client: Rohit Communities
Job No.: 220978
Location: 3430 Carling Avenue
Date: March 28, 2023

Sheet 15

Storm Sewer Design Sheet (5-yr storm)

LOCATION									TIME	RAINFALL	PEAK
FROM	TO	Total Area (ha)	C 0.20	C 0.70	C 0.90	Actual R (‘C’)	INDIV 2.78 AR	ACCUM 2.78 AR	OF CONC.	INTENSITY I	FLOW Q (l/s)
CA1&CA2	MAIN	0.261	0.000	0.000	0.261	0.90	0.65	0.65	10.00	104.19	68.0
CA3	MAIN	0.174	0.071	0.013	0.090	0.60	0.29	0.29	10.00	104.19	30.2

PROPOSED SEWER											
TYPE	PIPE	PIPE			FULL FLOW	TIME OF	EXCESS		Restricted	Restricted	Q100yr/
OF	SIZE	SLOPE	LENGTH	CAPACITY	VELOCITY	FLOW	CAPACITY	Q/Qfull		Flow Rate	Qfull
PIPE	(mm)	(%)	(m)	(l/s)	(m/s)	(min.)	(l/s)				
PVC	300.0	1.3	12.7	110.4	1.56	0.14	12.12	0.89	Yes	42.20	0.38

Rainfall Intensity = $998.071 / (T + 6.053)^{-0.814}$ T = time in minutes
 (City of Ottawa, 5 year storm)



Appendix B: Product Information and Roof Drawings

- Accutrol Weirs Flow Control and Roof Drains Sheets
- Typical Roof Plan from Architect
- Typical Tank Schematic – Boyd Bros Concrete Products 12,260L Tank
- Typical Tank Schematic – Boyd Bros Concrete Products 6,000L Tank



Adjustable Accutrol Weir

Tag: _____

Adjustable Flow Control for Roof Drains

ADJUSTABLE ACCUTROL (for Large Sump Roof Drains only)

For more flexibility in controlling flow with heads deeper than 2", Watts Drainage offers the Adjustable Accutrol. The Adjustable Accutrol Weir is designed with a single parabolic opening that can be covered to restrict flow above 2" of head to less than 5 gpm per inch, up to 6" of head. To adjust the flow rate for depths over 2" of head, set the slot in the adjustable upper cone according to the flow rate required. Refer to Table 1 below.
 Note: Flow rates are directly proportional to the amount of weir opening that is exposed.

EXAMPLE:

For example, if the adjustable upper cone is set to cover 1/2 of the weir opening, flow rates above 2" of head will be restricted to 2-1/2 gpm per inch of head.

Therefore, at 3" of head, the flow rate through the Accutrol Weir that has 1/2 the slot exposed will be:
 [5 gpm (per inch of head) x 2 inches of head] + 2-1/2 gpm (for the third inch of head) = 12-1/2 gpm.

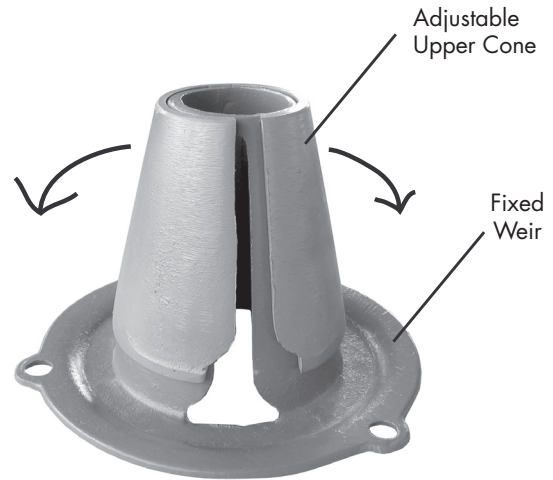
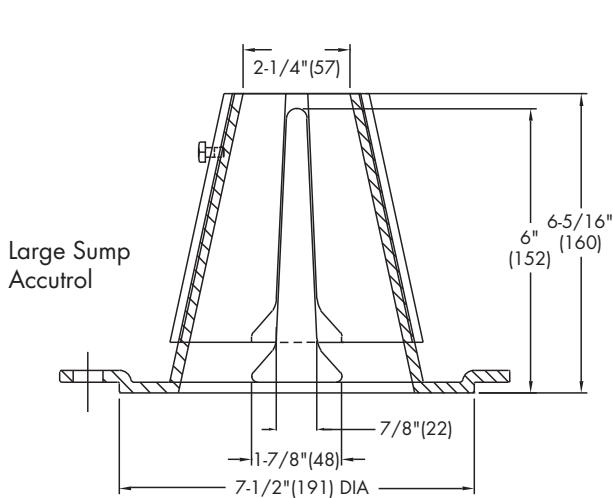

1/2 Weir Opening Exposed Shown Above

TABLE 1. Adjustable Accutrol Flow Rate Settings

Weir Opening Exposed	1"	2"	3"	4"	5"	6"
	Flow Rate (gallons per minute)					
Fully Exposed	5	10	15	20	25	30
3/4	5	10	13.75	17.5	21.25	25
1/2	5	10	12.5	15	17.5	20
1/4	5	10	11.25	12.5	13.75	15
Closed	5	5	5	5	5	5

Job Name _____
 Job Location _____
 Engineer _____

Contractor _____
 Contractor's P.O. No. _____
 Representative _____

Watts product specifications in U.S. customary units and metric are approximate and are provided for reference only. For precise measurements, please contact Watts Technical Service. Watts reserves the right to change or modify product design, construction, specifications, or materials without prior notice and without incurring any obligation to make such changes and modifications on Watts products previously or subsequently sold.

USA: Tel: (800) 338-2581 • Fax: (828) 248-3929 • Watts.com
 Canada: Tel: (905) 332-4090 • Fax: (905) 332-7068 • Watts.ca
 Latin America: Tel: (52) 81-1001-8600 • Fax: (52) 81-8000-7091 • Watts.com



1. THE CONTRACTOR SHALL VERIFY ALL DIMENSIONS AND LOCATIONS OF ALL EXISTING CONDITIONS.
2. THE CONTRACTOR SHALL VERIFY THE LOCATION AND DEPTH OF ALL EXISTING FOUNDATIONS.
3. THE CONTRACTOR SHALL VERIFY THE LOCATION AND DEPTH OF ALL EXISTING FOUNDATIONS.
4. THE CONTRACTOR SHALL VERIFY THE LOCATION AND DEPTH OF ALL EXISTING FOUNDATIONS.
5. THE CONTRACTOR SHALL VERIFY THE LOCATION AND DEPTH OF ALL EXISTING FOUNDATIONS.
6. THE CONTRACTOR SHALL VERIFY THE LOCATION AND DEPTH OF ALL EXISTING FOUNDATIONS.
7. THE CONTRACTOR SHALL VERIFY THE LOCATION AND DEPTH OF ALL EXISTING FOUNDATIONS.
8. THE CONTRACTOR SHALL VERIFY THE LOCATION AND DEPTH OF ALL EXISTING FOUNDATIONS.
9. THE CONTRACTOR SHALL VERIFY THE LOCATION AND DEPTH OF ALL EXISTING FOUNDATIONS.
10. THE CONTRACTOR SHALL VERIFY THE LOCATION AND DEPTH OF ALL EXISTING FOUNDATIONS.

WEST BUILDING

EAST BUILDING

DATE: 11/11/11

ISSUE RECORD



project studio
Project Studio Incorporated
10000 W. 12th Street
Overland Park, KS 66211

3430 CARLING
3430 Carling Avenue
Ottawa, OH

SCALE: DRAWN: REVISIONS:
2204 NOTED GS RINK

WEST BUILDING ROOF PLAN

A107W

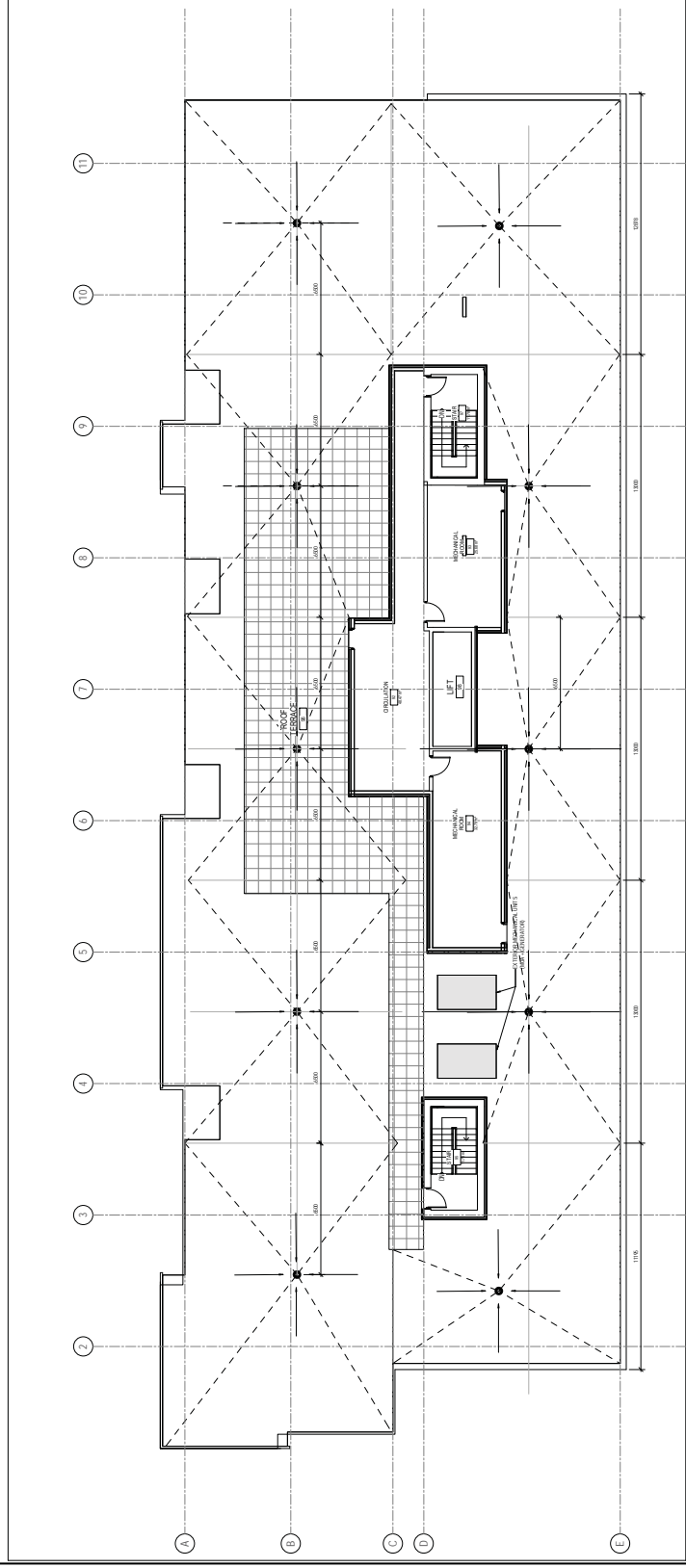

1. ROOF LEVEL - WEST BUILDING
SCALE: 1/8" = 1'-0"

1. THE CONTRACTOR SHALL VERIFY THE EXISTING CONDITIONS AND REPORT ANY DISCREPANCIES TO THE ARCHITECT PRIOR TO COMMENCEMENT OF WORK.
2. THE CONTRACTOR SHALL BE RESPONSIBLE FOR OBTAINING ALL NECESSARY PERMITS AND APPROVALS FROM THE LOCAL, STATE, AND FEDERAL AUTHORITIES.
3. THE CONTRACTOR SHALL MAINTAIN ACCESS TO ALL ADJACENT PROPERTIES AND UTILITIES AT ALL TIMES.
4. THE CONTRACTOR SHALL PROTECT ALL EXISTING UTILITIES AND STRUCTURES NOT TO BE REMOVED.
5. THE CONTRACTOR SHALL MAINTAIN THE EXISTING CURB CUT AND DRIVEWAY LOCATIONS.
6. THE CONTRACTOR SHALL MAINTAIN THE EXISTING LANDSCAPE AND PLANTINGS.
7. THE CONTRACTOR SHALL MAINTAIN THE EXISTING SIDEWALKS AND DRIVEWAYS.
8. THE CONTRACTOR SHALL MAINTAIN THE EXISTING DRIVEWAY AND SIDEWALK LOCATIONS.
9. THE CONTRACTOR SHALL MAINTAIN THE EXISTING DRIVEWAY AND SIDEWALK LOCATIONS.
10. THE CONTRACTOR SHALL MAINTAIN THE EXISTING DRIVEWAY AND SIDEWALK LOCATIONS.
11. THE CONTRACTOR SHALL MAINTAIN THE EXISTING DRIVEWAY AND SIDEWALK LOCATIONS.
12. THE CONTRACTOR SHALL MAINTAIN THE EXISTING DRIVEWAY AND SIDEWALK LOCATIONS.
13. THE CONTRACTOR SHALL MAINTAIN THE EXISTING DRIVEWAY AND SIDEWALK LOCATIONS.
14. THE CONTRACTOR SHALL MAINTAIN THE EXISTING DRIVEWAY AND SIDEWALK LOCATIONS.
15. THE CONTRACTOR SHALL MAINTAIN THE EXISTING DRIVEWAY AND SIDEWALK LOCATIONS.
16. THE CONTRACTOR SHALL MAINTAIN THE EXISTING DRIVEWAY AND SIDEWALK LOCATIONS.
17. THE CONTRACTOR SHALL MAINTAIN THE EXISTING DRIVEWAY AND SIDEWALK LOCATIONS.
18. THE CONTRACTOR SHALL MAINTAIN THE EXISTING DRIVEWAY AND SIDEWALK LOCATIONS.
19. THE CONTRACTOR SHALL MAINTAIN THE EXISTING DRIVEWAY AND SIDEWALK LOCATIONS.
20. THE CONTRACTOR SHALL MAINTAIN THE EXISTING DRIVEWAY AND SIDEWALK LOCATIONS.
21. THE CONTRACTOR SHALL MAINTAIN THE EXISTING DRIVEWAY AND SIDEWALK LOCATIONS.
22. THE CONTRACTOR SHALL MAINTAIN THE EXISTING DRIVEWAY AND SIDEWALK LOCATIONS.
23. THE CONTRACTOR SHALL MAINTAIN THE EXISTING DRIVEWAY AND SIDEWALK LOCATIONS.
24. THE CONTRACTOR SHALL MAINTAIN THE EXISTING DRIVEWAY AND SIDEWALK LOCATIONS.
25. THE CONTRACTOR SHALL MAINTAIN THE EXISTING DRIVEWAY AND SIDEWALK LOCATIONS.
26. THE CONTRACTOR SHALL MAINTAIN THE EXISTING DRIVEWAY AND SIDEWALK LOCATIONS.
27. THE CONTRACTOR SHALL MAINTAIN THE EXISTING DRIVEWAY AND SIDEWALK LOCATIONS.
28. THE CONTRACTOR SHALL MAINTAIN THE EXISTING DRIVEWAY AND SIDEWALK LOCATIONS.
29. THE CONTRACTOR SHALL MAINTAIN THE EXISTING DRIVEWAY AND SIDEWALK LOCATIONS.
30. THE CONTRACTOR SHALL MAINTAIN THE EXISTING DRIVEWAY AND SIDEWALK LOCATIONS.
31. THE CONTRACTOR SHALL MAINTAIN THE EXISTING DRIVEWAY AND SIDEWALK LOCATIONS.
32. THE CONTRACTOR SHALL MAINTAIN THE EXISTING DRIVEWAY AND SIDEWALK LOCATIONS.
33. THE CONTRACTOR SHALL MAINTAIN THE EXISTING DRIVEWAY AND SIDEWALK LOCATIONS.
34. THE CONTRACTOR SHALL MAINTAIN THE EXISTING DRIVEWAY AND SIDEWALK LOCATIONS.
35. THE CONTRACTOR SHALL MAINTAIN THE EXISTING DRIVEWAY AND SIDEWALK LOCATIONS.
36. THE CONTRACTOR SHALL MAINTAIN THE EXISTING DRIVEWAY AND SIDEWALK LOCATIONS.
37. THE CONTRACTOR SHALL MAINTAIN THE EXISTING DRIVEWAY AND SIDEWALK LOCATIONS.
38. THE CONTRACTOR SHALL MAINTAIN THE EXISTING DRIVEWAY AND SIDEWALK LOCATIONS.
39. THE CONTRACTOR SHALL MAINTAIN THE EXISTING DRIVEWAY AND SIDEWALK LOCATIONS.
40. THE CONTRACTOR SHALL MAINTAIN THE EXISTING DRIVEWAY AND SIDEWALK LOCATIONS.
41. THE CONTRACTOR SHALL MAINTAIN THE EXISTING DRIVEWAY AND SIDEWALK LOCATIONS.
42. THE CONTRACTOR SHALL MAINTAIN THE EXISTING DRIVEWAY AND SIDEWALK LOCATIONS.
43. THE CONTRACTOR SHALL MAINTAIN THE EXISTING DRIVEWAY AND SIDEWALK LOCATIONS.
44. THE CONTRACTOR SHALL MAINTAIN THE EXISTING DRIVEWAY AND SIDEWALK LOCATIONS.
45. THE CONTRACTOR SHALL MAINTAIN THE EXISTING DRIVEWAY AND SIDEWALK LOCATIONS.
46. THE CONTRACTOR SHALL MAINTAIN THE EXISTING DRIVEWAY AND SIDEWALK LOCATIONS.
47. THE CONTRACTOR SHALL MAINTAIN THE EXISTING DRIVEWAY AND SIDEWALK LOCATIONS.
48. THE CONTRACTOR SHALL MAINTAIN THE EXISTING DRIVEWAY AND SIDEWALK LOCATIONS.
49. THE CONTRACTOR SHALL MAINTAIN THE EXISTING DRIVEWAY AND SIDEWALK LOCATIONS.
50. THE CONTRACTOR SHALL MAINTAIN THE EXISTING DRIVEWAY AND SIDEWALK LOCATIONS.



DATE: 10/15/2024

PROJECT RECORD



project studio
Project Studio Incorporated
10101 Main Street, Suite 100
Cincinnati, OH 45241

3430 CARLING
3430 Carling Avenue
Ottawa, OH

SCALE: DRAWN BY: REVIEWED BY:
2204 NOTED GS RW

EAST BUILDING ROOF PLAN

A107E

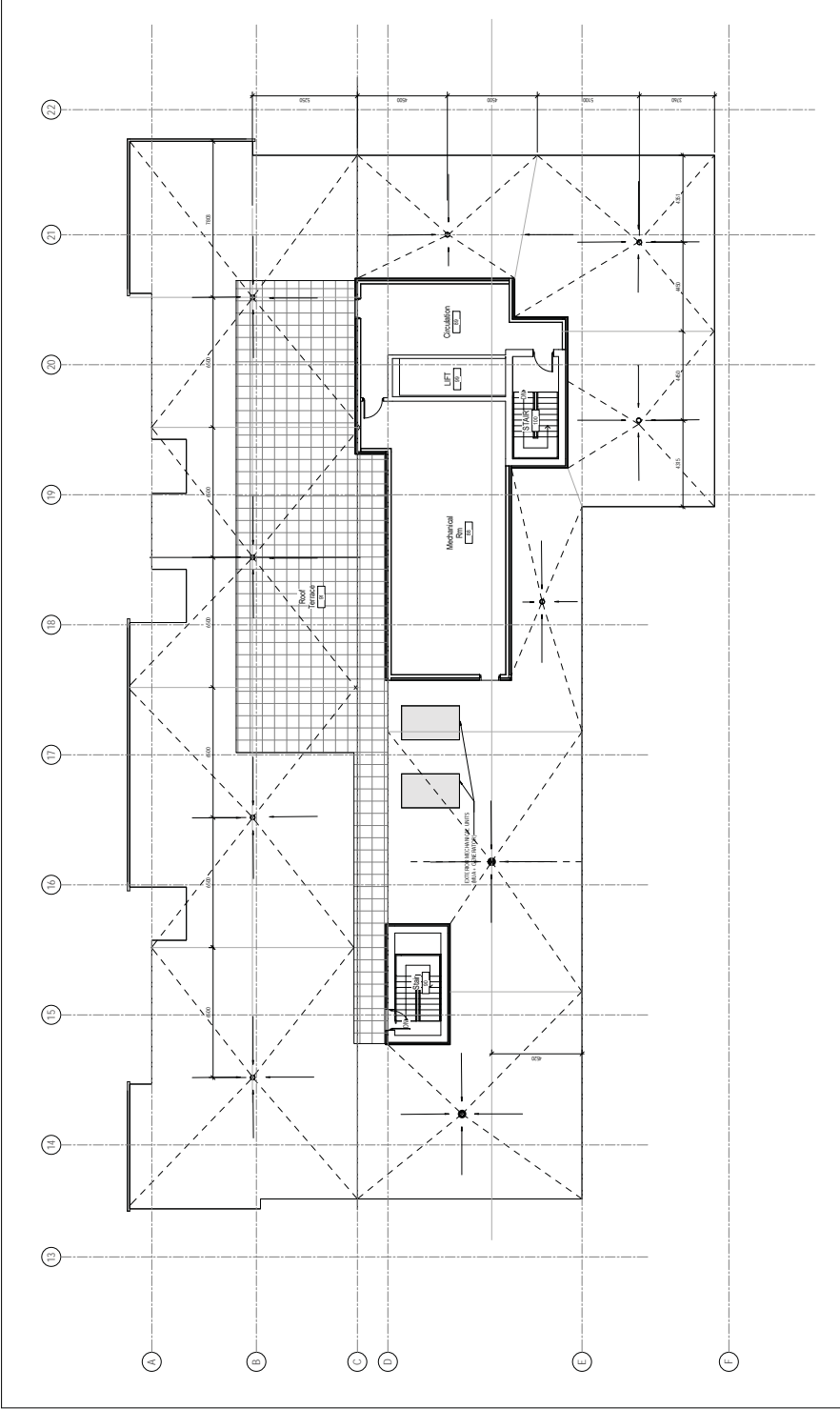

1 ROOF LEVEL - EAST BUILDING
SCALE: 1/8" = 1'-0"

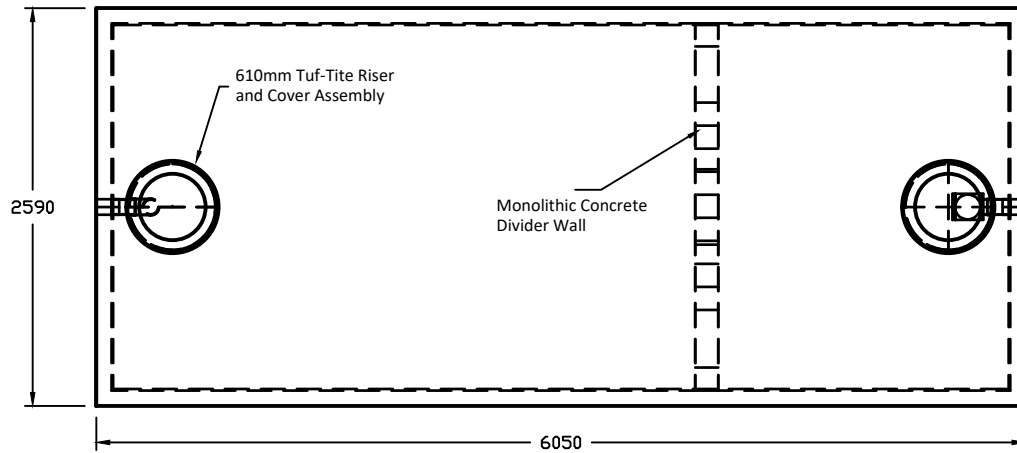

WORKING VOLUME: 12260L
 TOTAL VOLUME: 15400L

CONCRETE: 35 MPa WITH 5-8% AIR ENTRAINMENT
 NON-SULPHATE RESISTANT

REINFORCING: WALLS, FLOOR, AND LID
 10M@ 200mm O/C E/W
 10M BAR DIAGONALS AT EACH CORNER OF LID OPENINGS

WEIGHT: TOP SECTION: 4700 KGS
 BOTTOM SECTION: 11335 KGS
 TOTAL: 16050 KGS

MAXIMUM BURIAL DEPTH: 1200mm (48")

WATER TIGHTNESS: 1X ROW CON-SEAL CS-102-3/4 MASTIC SEALANT BETWEEN PIECES.
 SEALANT APPLIED ONSITE BY BOYD BROS CONCRETE ACCORDING TO MANUFACTURER'S
 RECOMMENDED METHOD.

PIPE/WALL CONNECTIONS: POLYLOK IV 100mm HIGH PRESSURE SEAL CAST IN CONCRETE

ACCESS OPENINGS: TUF-TITE 610mmx300mm RISER AND LID. ADDITIONAL RISERS
 AVAILABLE. OPSD AND PUMP ACCESS LIDS AVAILABLE.

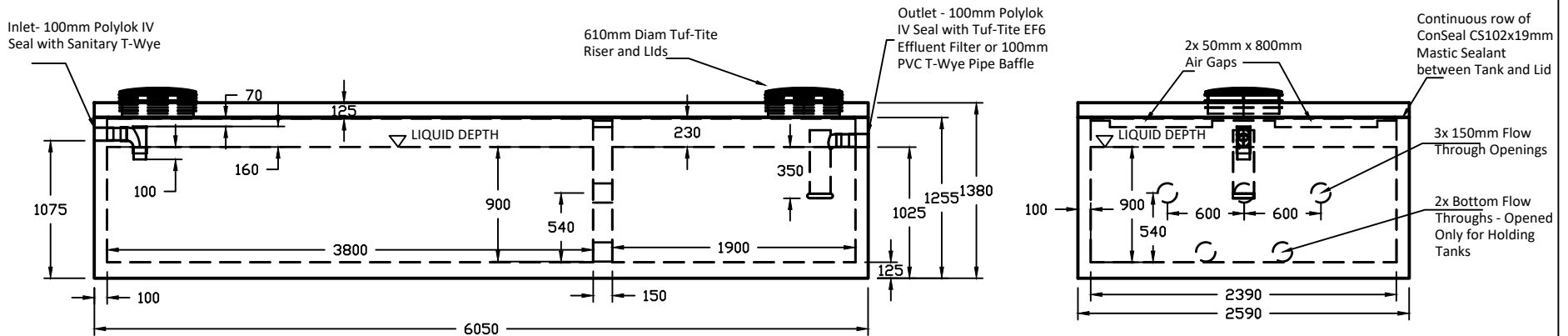

bb BOYD BROS
 concrete products

BOYD BROTHERS
 5450 CUDDY ST, OSGOOD, ONT, K0A 2W0
 tel (613) 826-2318 fax (613) 826-3679
 toll free 888-846-6664
 website www.boydbrosconcrete.ca
 e-mail info@boydbrosconcrete.ca

PRODUCT		
12200 LB 2-COMPARTMENT SEPTIC TANK		
SERIES NO	MODEL NO	MODELS IN SERIES
BigBlue	12	12, 13, 18, 23, 27, 30, 34, 41
SCALE	REV	DATE
1:1400	5.0	JUNE 14, 2019

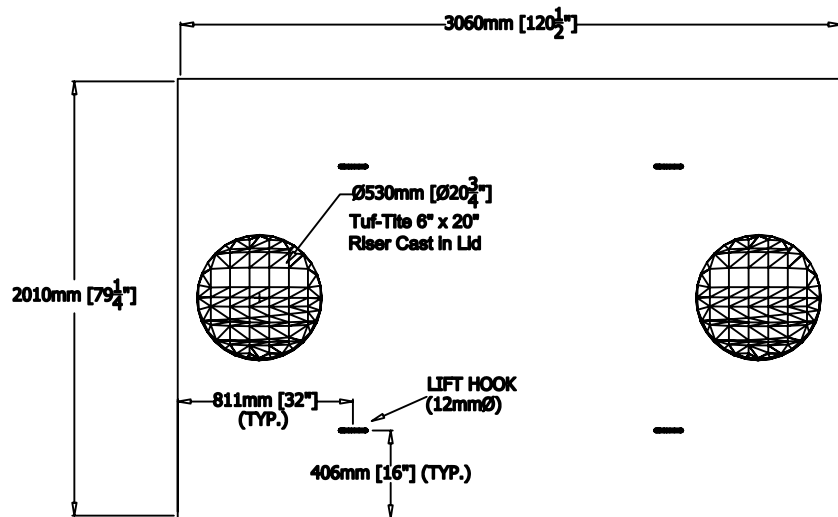

WORKING VOLUME: 6000 LITRES (1320 GAL)
 TOTAL VOLUME: 7100 LITRES (1560 GAL)
 CONCRETE: 32 MPa WITH 5-8 % AIR ENTRAINMENT
 NON-SULPHATE RESISTANT
 325mL/METRE EUCLID EUCON WR WATER REDUCER
 1700mL / METRE EUCLID PLASTOL 341 PLASTICIZER
 REINFORCING: 10M DEFORMED BAR W/ MIN 25mm (1") COVER
 WALLS AND BASE @ 600mm O/C EW
 LID @ 375mm O/C EW

WEIGHT: TOP SECTION - 1840 Kg (4120 lbs)
 BOTTOM SECTION W/ DIV - 4220 Kg (9450 lbs)
 TOTAL - 6060 Kg (13570 lbs)

MAXIMUM BURIAL DEPTH: 600mm (24")

WATER TIGHTNESS: CON-SEAL CS-102 MASTIC SEALANT BETWEEN LID AND
 BOTTOM SECTION APPLIED IN FACTORY ACCORDING TO MANUFACTURER'S
 RECOMMENDED METHOD

CENTRE WALL MONOLITHIC WITH TANK BODY.
 TANK BODY LIFTED USING A SLING

PIPE / WALL CONNECTIONS:

INLET: POLYLOK IV HIGH PRESSURE SEAL CAST IN CONCRETE WITH BAFFLE
 INSTALLED.

OUTLET: 100mm (4") PVC COUPLER CAST IN CONCRETE WITH FILTER INSTALLED.
 INLET BAFFLE AND EFFLUENT FILTER EXTEND 100mm AND 400mm, RESPECTIVELY,
 BELOW LIQUID.

OPEN-TOPPED EFFLUENT FILTER EXTENDS VERTICALLY TO AT LEAST THE TOP OF
 CHAMBER DIVIDER WITH 25mm MIN. AIR SPACE.

TUF-TITE 6" X 20" RISERS CAST IN CONCRETE FOR ACCESS. CONCRETE HATCHES
 OPTIONAL.

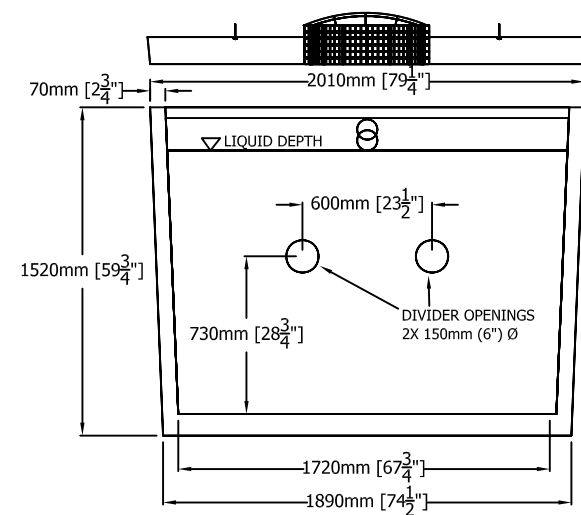
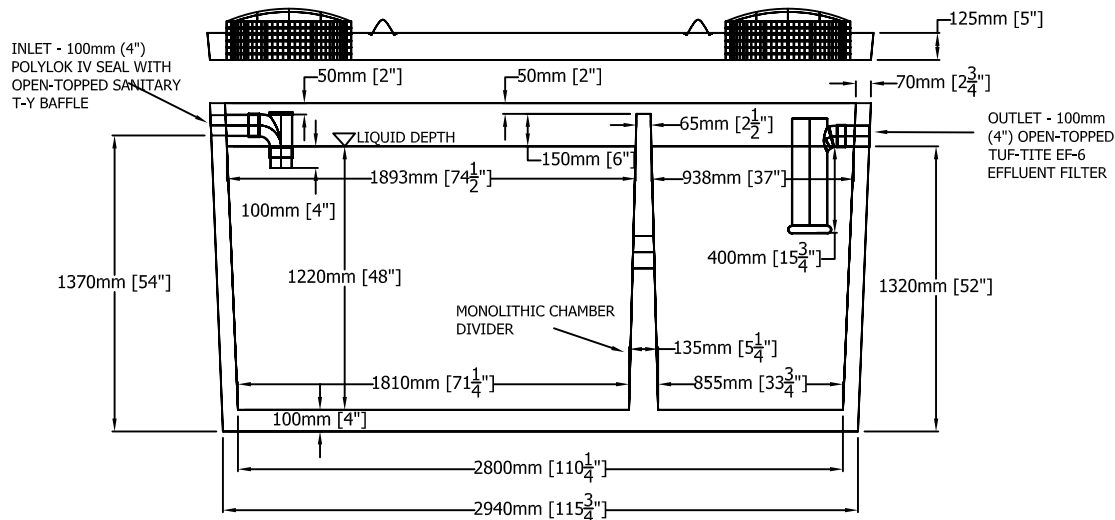

bb BOYD BROS
 concrete products and septic pumping

BOYD BROTHERS

5450 CUDDY ST
 OSGOODE, ONT, K0A 2W0
 tel (613) 826-2318
 fax (613) 826-3679
 toll free 888-846-6664

PRODUCT 6000L (1320 GAL) REGULAR SEPTIC TANK		
SERIES NO 6000	MODEL NO 6000R	MODELS IN SERIES 6000R
SCALE 1:35	REV 6.0	DATE JUNE 19, 2007



Appendix C: Correspondence

The pre-consultation notes have been copied without revision from the Assessment of Adequacy of Public Services 3430 Carling Avenue Report prepared by J.L. Richards & Associates Ltd dated July 16, 2021.

The pre-consultation was for a proposed development consisting of 2 buildings of 9 storeys having a similar foot print and number of units.

3430 Carling
Pre-Consultation Meeting Minutes
Meeting Date: February 22, 2021

Attendee	Role	Organization
Lisa Stern	Planner	City of Ottawa
Randolph Wang	Urban Designer	
Neeti Paudel	Transportation	
Reid Shepherd	Parks Planner	
Jessica Valic	Infrastructure PM	
Mark Richardson	Forester	
Miguel Tremblay	Planner	Fotenn
Nico Church	Planner	
Edward Hayes		
Lucie Dalrymple		
Randy Koolwine		
Guy Forget		
Raphael Esposito		
Mark Baker		

Comments from the Applicant:

1. Develop two 9 storey buildings on a 4 storey podium on the subject lands.

Planning Comments:

1. The proposal is subject to a Major Zoning Bylaw Amendment and Complex Site Plan application. The application form, timeline and fees can be found [here](#).
2. The subject lands are designated General Urban Area in the City's Official Plan and are zoned GM20[2628]H18.5. The site specific exception permits a non-accessory parking lot as a temporary use on the subject lands.
3. The permitted FSI on the site is 2.0, as such Section 37 applies to the proposal.
4. Cash-in-lieu of parkland and associated appraisal fee will be required as a condition of approval as per the [Parkland Dedication Bylaw](#).
5. The site is not located within a target area of intensification as identified under Section 2.2.2 Policy 3, nor is the site located in proximity to rapid transit. Building heights within the General Urban Area will be predominantly low-rise. High-rise may be considered for sites that are in proximity to frequent transit or are in an area already characterized by taller buildings but still subject to compatibility analysis.
6. Although the larger deep parcels at the west and east ends of block permit heights up to 34m, the property to the east zoned LC (Local Commercial) Zone has a permitted height of 12m.
7. It will be up to the applicant to demonstrate what compatibility measures are put in place such that the proposal fits well with the abutting low-rise residential homes as well as those across Carling.
8. The planning rationale should discuss existing context of the surrounding area and demonstrate compatibility with abutting uses including the low rise residential across Carling and should discuss transitions including landscaping along the northerly property line and access/circulation.
9. Please consult with the Ward Councillor prior to submission.

Urban Design:

1. A Design Brief is required as part of the submission. The Terms of Reference of the Design Brief is attached for convenience. The proposed 9-storey buildings are significantly taller than the surrounding buildings. Therefore, a wind study is required in addition to a shadow study. The standard Terms of Reference for a wind study can be found [here](#).
2. With respect to the design concept presented at the preconsultation meeting:
 - a. The narrow bar building (approximately 16m in depth) concept is quite refreshing.
 - b. The intent to stagger the two buildings is also appreciated. However, the placement of the buildings should take into considerations a number of factors, including the ability to provide effective built form transition to the low-rise area to the south. While a continuous street wall condition along Carling may not be most desirable at this location, it is conceivable that locating the proposed buildings as further away from the low-rise area will be most effective to address concerns of transition.
 - c. Considerations should be given to differentiating the two buildings with respect to both massing and architecture.
 - d. The proposed 4-storey podium may be inappropriate for the context. Considerations should be given to a 2 or 3 storey podium to reflect the form of the existing buildings in the vicinities.
 - e. Please demonstrate how transition will occur at the back of the site. The 45 degree angular plane is a common tool to use to measure the effectiveness of built form transition.
 - f. Please ensure the provision of a landscape buffer along the rear fence as required by zoning to allow for landscape screening and healthy growth of canopy trees.
 - g. The site is isolated from the surrounding neighbourhood. Sufficient at grade amenity spaces should be provided at the rear of the property.
3. It is important to explore a few site plan and massing options in the next step. A second preconsultation may be required once these options are developed.

Forestry:

1. a Tree Conservation Report (TCR) must be supplied for review along with the suite of other plans/reports required by the City
 - a. an approved TCR is a requirement of Site Plan approval.
 - b. The TCR may be combines with the Landscape Plan
2. As of January 1 2021, any removal of privately or publicly (City) owned trees 10cm or larger in diameter requires a tree permit issued under the Tree Protection Bylaw (Bylaw 2020 – 340); the permit will be based on an approved TCR and made available at or near plan approval.
3. The Planning Forester from Planning and Growth Management as well as foresters from Forestry Services will review the submitted TCR
 - a. If tree removal is required, both municipal and privately-owned trees will be addressed in a single permit issued through the Planning Forester
 - b. Compensation may be required for city owned trees – if so, it will need to be paid prior to the release of the tree permit
4. the TCR must list all trees on site by species, diameter and health condition
5. the TCR must list all trees on adjacent sites if they have a critical root zone that extends onto the development site

6. Trees should be identified by ownership – Privately owned on-site trees; Privately owned off-site trees; City owned trees; Co-owned trees (growing on a property boundary)
7. If trees are to be removed, the TCR must clearly show where they are, and document the reason they cannot be retained
8. All retained trees must be shown and all retained trees within the area impacted by the development process must be protected as per City guidelines available at [Tree Protection Specification](#) or by searching Ottawa.ca
 - a. the location of tree protection fencing must be shown on a plan
 - b. show the critical root zone of the retained trees
 - c. if excavation will occur within the critical root zone, please show the limits of excavation
9. the City encourages the retention of healthy trees; if possible, please seek opportunities for retention of trees that will contribute to the design/function of the site.
10. For more information on the process or help with tree retention options, contact Mark Richardson mark.richardson@ottawa.ca or on [City of Ottawa](#)

Transportation:

1. Follow Traffic Impact Assessment Guidelines
 - a. Start this process as soon as possible.
 - b. Applicant advised that their application will not be deemed complete until the submission of the draft step 1-4, including the functional draft RMA package (if applicable) and/or monitoring report (if applicable). Collaboration and communication between development proponents and City staff are required at the end of every step of the TIA process.
 - c. Request base mapping asap if RMA is required. Contact Engineering Services (<https://ottawa.ca/en/city-hall/planning-and-development/engineering-services>)
2. Noise Impact Studies required for the following:
 - a. Road
 - b. Stationary (due to the proximity to neighbouring exposed mechanical equipment) or (if there will be any exposed mechanical equipment due to the proximity to neighbouring noise sensitive land uses)
3. Clear throat requirements for more than 250 apartment units on an arterial/major collector is 40m.
4. Right of way protection on Carling Road at this location is 44.5m. Ensure this is protected.
5. On site plan:
 - a. Show all details of the roads abutting the site up to and including the opposite curb; include such items as pavement markings, accesses and/or sidewalks.
 - b. Turning templates will be required for all accesses showing the largest vehicle to access the site; required for internal movements and at all access (entering and exiting and going in both directions).
 - c. Show all curb radii measurements; ensure that all curb radii are reduced as much as possible
 - d. Show lane/aisle widths.
 - e. Sidewalk is to be continuous across access as per City Specification 7.1.
6. The City recommends development on private property be in accordance with the Accessibility Design Standards (AODA legislation). As the site proposed is residential, it is suggested that the design conforms to the Site Plan Checklist, which summarizes AODA requirements (attached).

Engineering:

Water

Available Watermain: 305mm (CI)

- Per WDG 4.3.1, where basic demand is greater than 50 m³/day, there shall be a minimum of two water services, separated by an isolation valve, to avoid creation of vulnerable service area
- Per WDG 4.4.7.2, District Meter Area (DMA) Chamber is required for services greater than 150mm in diameter

Boundary Conditions

Request prior to first submission. Contact assigned City Infrastructure Project Manager with the following information:

- Location of service(s)
- Type of development and required fire flow (per FUS method – include FUS calculation sheet with boundary condition request)
- Average Daily Demand (l/s)
- Maximum Hourly Demand (l/s)
- Maximum Daily Demand (l/s)

Sanitary

Available Sanitary Sewer: 375mm PVC

- There may be limited capacity in the downstream sewer system. Coordination will be required to determine if the existing sanitary sewer system has sufficient capacity to support the proposed development. Please confirm the proposed sanitary demands for the proposed development, calculated using the most up to date SDG, and provide to the City of Ottawa Infrastructure Project Manager.

Storm

Available Storm Sewer: 600mm (CONC)

- Roof drains to be connected downstream of any incorporated ICD within the SWM system.
- Where service lateral connection is greater than 50% of the diameter of the main sewer, a maintenance hole will be required at the connection.

Stormwater Management

- Quantity Control
 - Required for the site up to and including the 100-yr storm event.
 - Control to the 2-year storm event
 - Time of Concentration (T_c): pre-development or maximum=10min
 - Allowable runoff coefficient(c): Lesser of pre-development or c=0.5.
 - If underground/inline stormwater storage is proposed, an average release rate equal to 50% of the determined peak allowable rate must be used. Otherwise, disregard the underground/inline storage as available storage or provide modeling to support the proposed design. The reasoning for this restriction is that the discharge rate at full storage is not representative of the discharge rate for more frequent storm events. Halving the discharge rate compensates for the inaccuracies of the modified rational method when underground storage is used.
 - Provide both pre and post development stormwater management plans, showing individual drainage areas and their respective coefficients.
 - If roof storage is proposed, please provide a roof drainage plan showing the 5 and 100-year storm ponding levels. Include the roof drain type, opening settings, and flow rate.

- Quality Control: Please consult with the Mississippi Valley Conservation Authority (MVCA) regarding water quality control restrictions for the subject site. Include correspondence in report.
- Ministry of Environment, Conservation, and Parks (MECP): Designer to determine if approval for sewage works under Section 53 of OWRA is required and to determine the type of application required. Reviews will be done through Transfer of Review or Direct Submission.

Phase I and Phase II ESA

- Phase I ESA is a requirement; Phase II ESA requirement will be dependent on the result of the Phase I ESA.
- Phase I ESA must include Ecolog ERIS Report.
- Phase I ESAs and Phase II ESAs must conform to clause 4.8.4 of the Official Plan that requires that development applications conform to Ontario Regulation 153/04.
- Phase I/II ESA to comment on the need for a Record of Site Condition for property development.

Geotechnical Investigation

- Required for entire development area
- Retaining walls greater than 1.0m must be designed by a Professional Engineer. Plans to be submitted with the Application.

Exterior Lighting

- If exterior light fixtures are proposed, provide a plan showing the location of all exterior fixtures and include a table providing fixture details (make, model, mounting heights). All external light fixtures must meet the criteria for full cut-off classification as recognized by the Illuminating Engineering Society of North America (IESNA or IES), resulting in minimal light spillage onto adjacent properties (as a guideline, 0.5 fc is normally the maximum allowable spillage). Provide certification from a relevant Professional Engineer.

Other

- Road cut moratorium in place on Carling Avenue. Road cuts may be prohibited in upcoming years and/or road cut fees increased. Specifics can be discussed when application is submitted.

General Information

1. The Servicing Study Guidelines for Development Applications are available at the following address: <https://ottawa.ca/en/city-hall/planning-and-development/information-developers/development-application-review-process/development-application-submission/guide-preparing-studies-and-plans#servicing-study-guidelines-development-applications>
2. Servicing and site works shall be in accordance with the following documents:
 - Ottawa Sewer Design Guidelines (October 2012) (including subsequent Technical Bulletins)
 - Ottawa Design Guidelines – Water Distribution (2010) (including subsequent Technical Bulletins)
 - Geotechnical Investigation and Reporting Guidelines for Development Applications in the City of Ottawa (2007)
 - Ottawa Standard Tender Documents (latest version)
3. Record drawings and utility plans are also available for purchase from the City (Contact the City's Information Centre by email at InformationCentre@ottawa.ca or by phone at (613) 580-2424 x.44455).

4. Any proposed work in utility easements requires written consent of easement owner.
5. All submitted report and plan pdf documents to be flattened and unsecured to allow for editing.
6. All documents prepared by Engineers shall be signed and dated on the seal.

Please refer to the links to [“Guide to preparing studies and plans”](#) and fees for general information. Additional information is available related to [building permits](#), [development charges](#), and the [Accessibility Design Standards](#). Be aware that other fees and permits may be required, outside of the development review process. You may obtain background drawings by contacting informationcentre@ottawa.ca.

These pre-con comments are valid for one year. If you submit a development application(s) after this time, you may be required to meet for another pre-consultation meeting and/or the submission requirements may change. You are as well encouraged to contact us for a follow-up meeting if the plan/concept will be further refined.

Please contact me at Lisa.Stern@ottawa.ca or at 613-580-2424 extension 21108 if you have any questions.

Guy Forget

From: Valic, Jessica <jessica.valic@ottawa.ca>
Sent: Wednesday, March 10, 2021 9:46 AM
To: Lucie Dalrymple
Cc: Nico Church; Raphaël Esposito; Guy Forget; Edward Hayes; Miguel Tremblay; Stern, Lisa; Valic, Jessica
Subject: RE: Questions for Pre-Consult for 3430 Carling Ave

Good Morning Lucie,

The sanitary sewer can accommodate the increase. Since this is a partially separated area, the system is impacted during severe wet weather periods. For this reason, a sanitary backwater valve will be a requirement.

Concerning the storm, control to the 5 year will be permitted.

Thanks,

Jessica

From: Lucie Dalrymple <ldalrymple@jlrichards.ca>
Sent: March 03, 2021 9:54 AM
To: Valic, Jessica <jessica.valic@ottawa.ca>
Cc: Nico Church <church@fotenn.com>; Raphaël Esposito <resposito@omnipex.ca>; Guy Forget <gforget@jlrichards.ca>; Edward Hayes <e.hayes@tempbridge.ca>; Miguel Tremblay <tremblay@fotenn.com>; Stern, Lisa <lisa.stern@ottawa.ca>
Subject: RE: Questions for Pre-Consult for 3430 Carling Ave

CAUTION: This email originated from an External Sender. Please do not click links or open attachments unless you recognize the source.

ATTENTION : Ce courriel provient d'un expéditeur externe. Ne cliquez sur aucun lien et n'ouvrez pas de pièce jointe, excepté si vous connaissez l'expéditeur.

Good morning Jessica,

Thank you for the detailed pre-consultation notes. Further to these notes, we wish to obtain confirmation from the City on the following:

Sanitary

In keeping with the recommendation noted in your pre-consultation notes, please find attached sanitary peak flow calculations for the City to review and confirm available residual capacity to accommodate the proposed redevelopment. Please note that the theoretical sanitary calculations were carried out based on a redevelopment of 250 residential units. Given that the unit statistics is unknown, a blended density of 1.8 person per unit (as per Table 4.1 of the OSDG) was used. Based on the assessment of peak flows for a 250-unit development, we have estimated the peak wastewater flows to be 5.16 L/s, an increase of 4.76 L/s compared to the existing theoretical wastewater of 0.20 L/s. Note that these peak flows include dry & wet I/I of 0.33 L/s per the latest Technical Bulletins.

Storm



Appendix D: Drawings

220978– PRE – Pre-Development Conditions

220978 –SWMP – Stormwater Management Plan and Catchment Areas

220978 – GR – Grading Plan

220978 – SER – Site Servicing Plan

220978 – ER – Erosion Control Plan

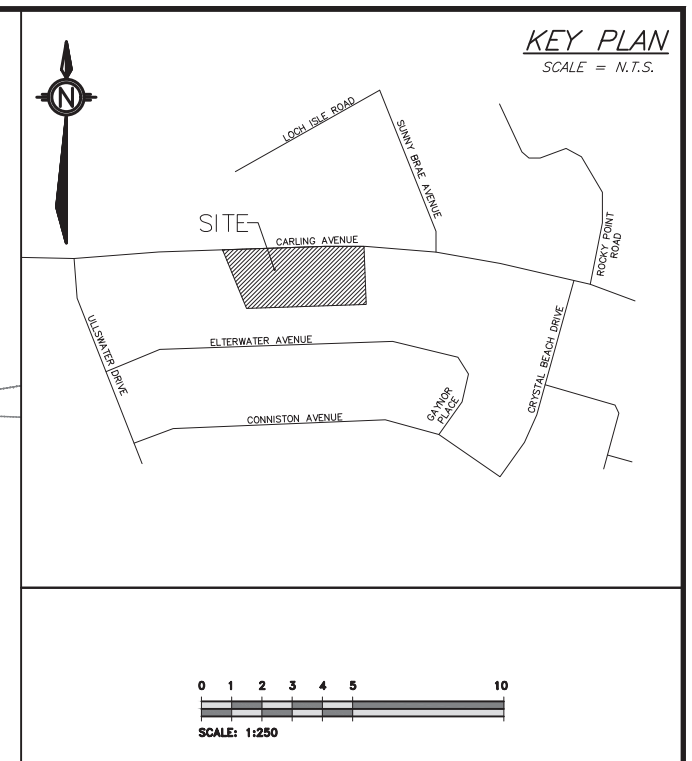

LEGEND (STORM WATER MANAGEMENT)

- CATCHMENT LABEL: 0.39, 0.34
- CATCHMENT AREA (HECTARES)
- RUNOFF COEFFICIENT
- CATCHMENT AREA BOUNDARY
- DIRECTION OF FLOW
- PROPERTY LINE
- SILT FENCE
- CONTROLLED AREA
- UNCONTROLLED AREA
- DRAINAGE PATTERN

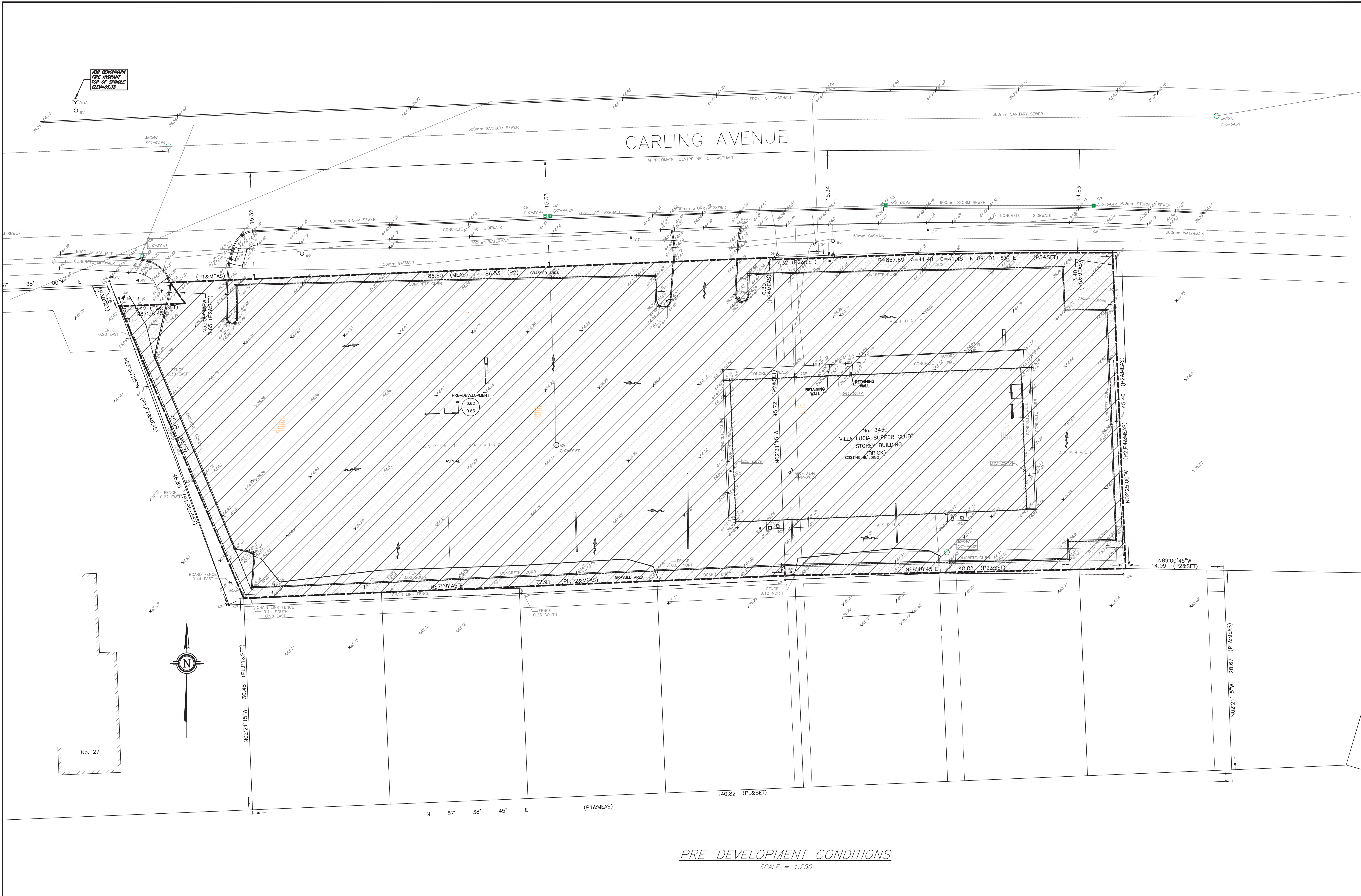

PRE-DEVELOPMENT CONDITIONS
SCALE = 1:250

NOTES:

- ALL DIMENSIONS ARE IN METRES, UNLESS OTHERWISE SPECIFIED. TOPOGRAPHIC SURVEY WAS PROVIDED BY STANTEC GEOMATICS LTD. TOPOGRAPHIC SURVEY IS GEODETIC AND REFERRED TO THE CVD-1928:1978 GEODETIC DATUM. BEARINGS ARE GRID, DERIVED FROM CAN-NET VRS NETWORK GPS OBSERVATIONS ARE REFERENCED TO SPECIFIED CONTROL POINTS 01919680005 AND 19773035 AND 19680191, MTM ZONE 9 (76°30' WEST LONGITUDE) NAD-83 (ORIGINAL)
- THIS IS NOT A LEGAL SURVEY.
- BOUNDARY INFORMATION DERIVED FROM STANTEC GEOMATICS LTD. CONTRACTOR TO VERIFY EXACT LOCATION AND REPORT ANY DISCREPANCIES TO KOLLAARD ASSOCIATES INC.
- CLIENT IS RESPONSIBLE FOR ACQUIRING ALL NECESSARY PERMITS.
- CONTRACTOR TO VERIFY THAT APPROPRIATE PERMITS HAVE BEEN ACQUIRED PRIOR TO ANY CONSTRUCTION.
- CONTRACTOR IS RESPONSIBLE FOR LOCATION AND PROTECTION OF UTILITIES.
- ALL DIMENSIONS TO BE VERIFIED ON SITE BY CONTRACTOR PRIOR TO CONSTRUCTION.
- THIS DRAWING IS NOT FOR CONSTRUCTION UNTIL ALL APPROVALS HAVE BEEN GRANTED.
- INSPECTION OF ROUGH GRADE BY KOLLAARD ASSOCIATES INC. AND CITY OF OTTAWA MUST BE CONDUCTED PRIOR TO PLACEMENT OF TOPSOIL OR SOD.
- HYDRO, GAS, COMMUNICATIONS SERVICE TO BE INSTALLED ACCORDING TO THE SPECIFICATIONS OF SERVICE PROVIDER AND THE MECHANICAL ENGINEER.
- ALL MATERIALS AND CONSTRUCTION TO BE IN ACCORDANCE WITH CITY OF OTTAWA STANDARDS AND ONTARIO PROVINCIAL STANDARDS AND SPECIFICATIONS.
- ANY CHANGES MADE TO THIS PLAN MUST BE VERIFIED AND APPROVED BY KOLLAARD ASSOCIATES, INC.
- THIS DRAWING IS PART OF KOLLAARD ASSOCIATES DESIGN REPORT #220978.

NO.	REVISION	DATE	BY
1	NO CHANGES TO THIS SHEET	28.MAR.2023	NJR
2	ISSUED FOR SITE PLAN CONTROL	14.DEC.2022	NJR

CONSULTANTS

Kollaard Associates Engineers

BOX 189
210 PRESOTT STREET
KENTVILLE, ONTARIO
K0G 1J0
FACSIMILE (613) 258-0475

(613) 860-0923

DESIGN: NJR, SD, APPROVED: SD

STAMP: LICENSED PROFESSIONAL ENGINEER, 28.MAR.2023, S.E. deWit, 100079612, PROVINCE OF ONTARIO

CLIENT NAME: ROHIT COMMUNITIES INC.	PROJECT No: 220978
PROJECT NAME: PROPOSED RESIDENTIAL DEVELOPMENT	DATE: 14.DEC.2022
PROJECT LOCATION: 3430 CARLING AVENUE, OTTAWA, ONTARIO	SCALE: 1:250
DRAWING: PRE-DEVELOPMENT CONDITIONS	DRAWING No: 220978-PRE

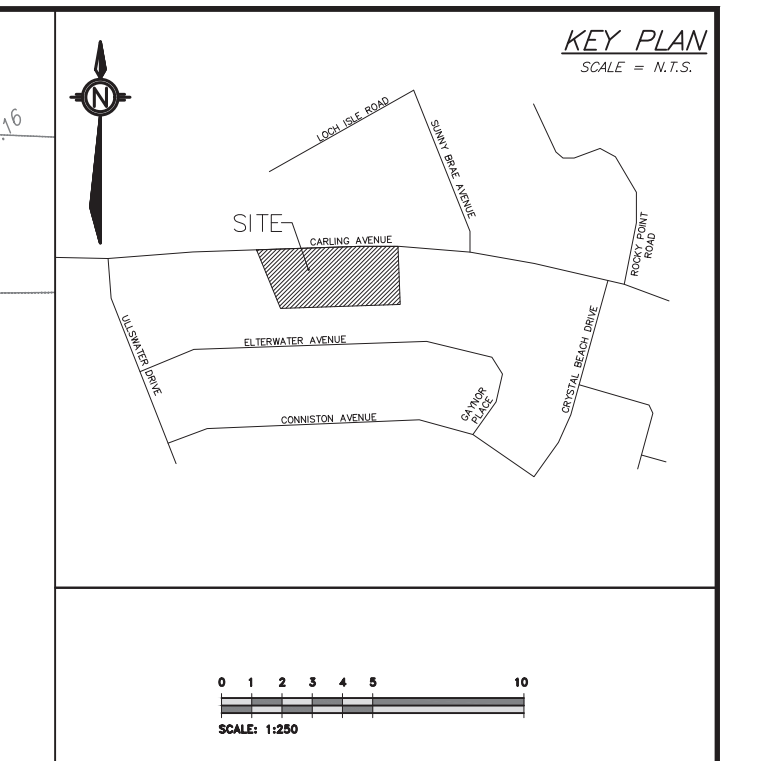
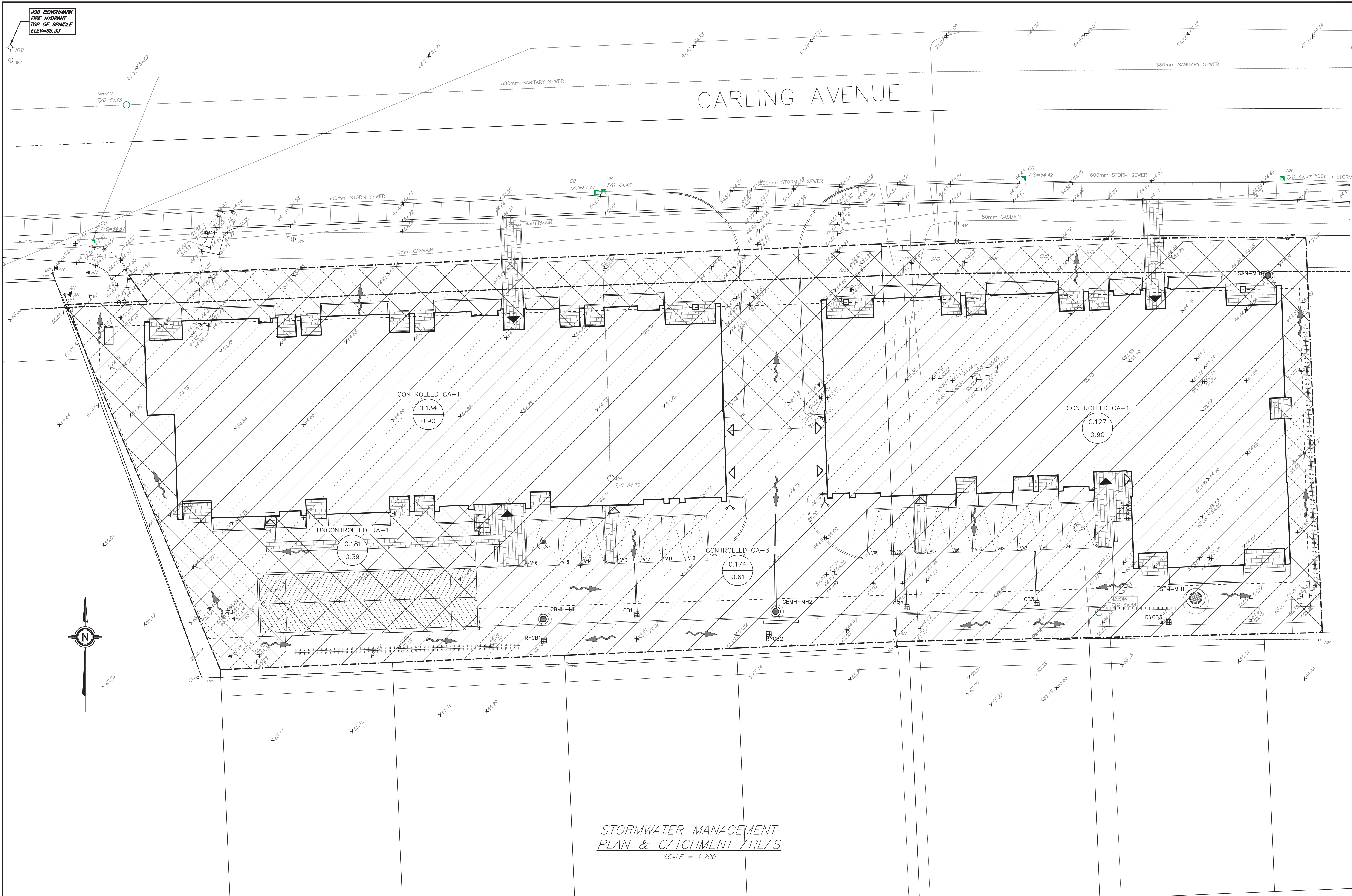

LEGEND (STORM WATER MANAGEMENT)

	CATCHMENT LABEL
	CATCHMENT AREA (HECTARES)
	RUNOFF COEFFICIENT
	CATCHMENT AREA BOUNDARY
	DIRECTION OF FLOW
	PROPERTY LINE
	SILT FENCE
	CONTROLLED AREA
	UNCONTROLLED AREA
	DRAINAGE PATTERN

*STORMWATER MANAGEMENT
PLAN & CATCHMENT AREAS*
SCALE = 1:200

NOTES:
 1. ALL DIMENSIONS ARE IN METRES, UNLESS OTHERWISE SPECIFIED. TOPOGRAPHIC SURVEY WAS PROVIDED BY STANTEC GEOMATICS LTD. TOPOGRAPHIC SURVEY IS GEODETIC AND REFERRED TO THE CVD-1928:1978 GEODETIC DATUM. BEARINGS ARE GRID, DERIVED FROM CAN-NET VRS NETWORK GPS OBSERVATIONS ARE REFERENCED TO SPECIFIED CONTROL POINTS 01919680005 AND 19773035 AND 19680191, MTM ZONE 9 (76°30' WEST LONGITUDE) NAD-83 (ORIGINAL)
 2. THIS IS NOT A LEGAL SURVEY.
 3. BOUNDARY INFORMATION DERIVED FROM STANTEC GEOMATICS LTD.
 4. EXISTING SERVICES INFORMATION SHOWN ARE BASED ON BEST CURRENT INFORMATION. CONTRACTOR TO VERIFY EXACT LOCATION AND REPORT ANY DISCREPANCIES TO KOLLAARD ASSOCIATES INC.
 5. CLIENT IS RESPONSIBLE FOR ACQUIRING ALL NECESSARY PERMITS.
 6. CONTRACTOR TO VERIFY THAT APPROPRIATE PERMITS HAVE BEEN ACQUIRED PRIOR TO

7. ANY CONSTRUCTION.
 7. CONTRACTOR IS RESPONSIBLE FOR LOCATION AND PROTECTION OF UTILITIES.
 8. ALL DIMENSIONS TO BE VERIFIED ON SITE BY CONTRACTOR PRIOR TO CONSTRUCTION.
 9. THIS DRAWING IS NOT FOR CONSTRUCTION UNTIL ALL APPROVALS HAVE BEEN GRANTED.
 10. INSPECTION OF ROUGH GRADE BY KOLLAARD ASSOCIATES INC. AND CITY OF OTTAWA MUST BE CONDUCTED PRIOR TO PLACEMENT OF TOPSOIL OR SOD.
 11. HYDRO, GAS, COMMUNICATIONS SERVICE TO BE INSTALLED ACCORDING TO THE SPECIFICATIONS OF SERVICE PROVIDER AND THE MECHANICAL ENGINEER.
 12. ALL MATERIALS AND CONSTRUCTION TO BE IN ACCORDANCE WITH CITY OF OTTAWA STANDARDS AND ONTARIO PROVINCIAL STANDARDS AND SPECIFICATIONS
 13. ANY CHANGES MADE TO THIS PLAN MUST BE VERIFIED AND APPROVED BY KOLLAARD ASSOCIATES, INC.
 14. THIS DRAWING IS PART OF KOLLAARD ASSOCIATES DESIGN REPORT #220978.

No.	REVISION	DATE	BY
1	RESPONSE TO 1ST REVIEW COMMENTS	28.MAR.2023	NJR
2	ISSUED FOR SITE PLAN CONTROL	14.DEC.2022	NJR

CONSULTANTS

BOX 189
210 PRESOTT STREET
KENTVILLE, ONTARIO
K0C 1J0
FACSIMILE (613) 258-0475
(613) 860-0923

DESIGN	NJR
DRAWN	NJR
CHECKED	SD
APPROVED	SD



CLIENT NAME	ROHIT COMMUNITIES INC.
PROJECT NAME	PROPOSED RESIDENTIAL DEVELOPMENT
PROJECT LOCATION	3430 CARLING AVENUE, OTTAWA, ONTARIO
DRAWING	STORMWATER MANAGEMENT PLAN & CATCHMENT AREAS

PROJECT No.	220978
DATE	14.DEC.2022
SCALE	1:250
DRAWING No.	220978 - SWMP

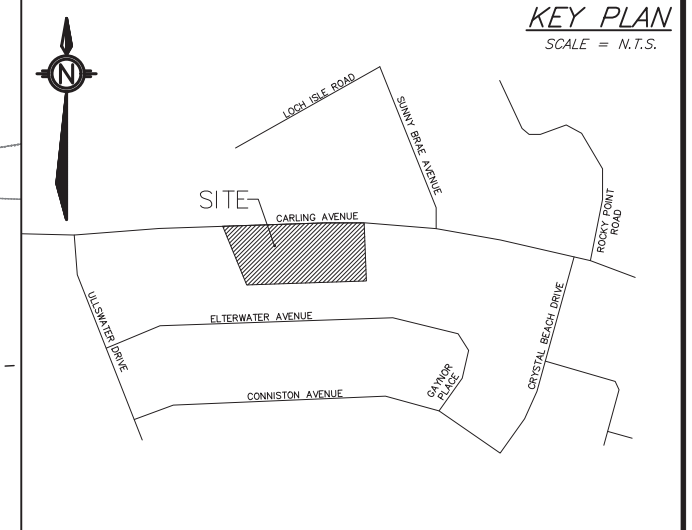
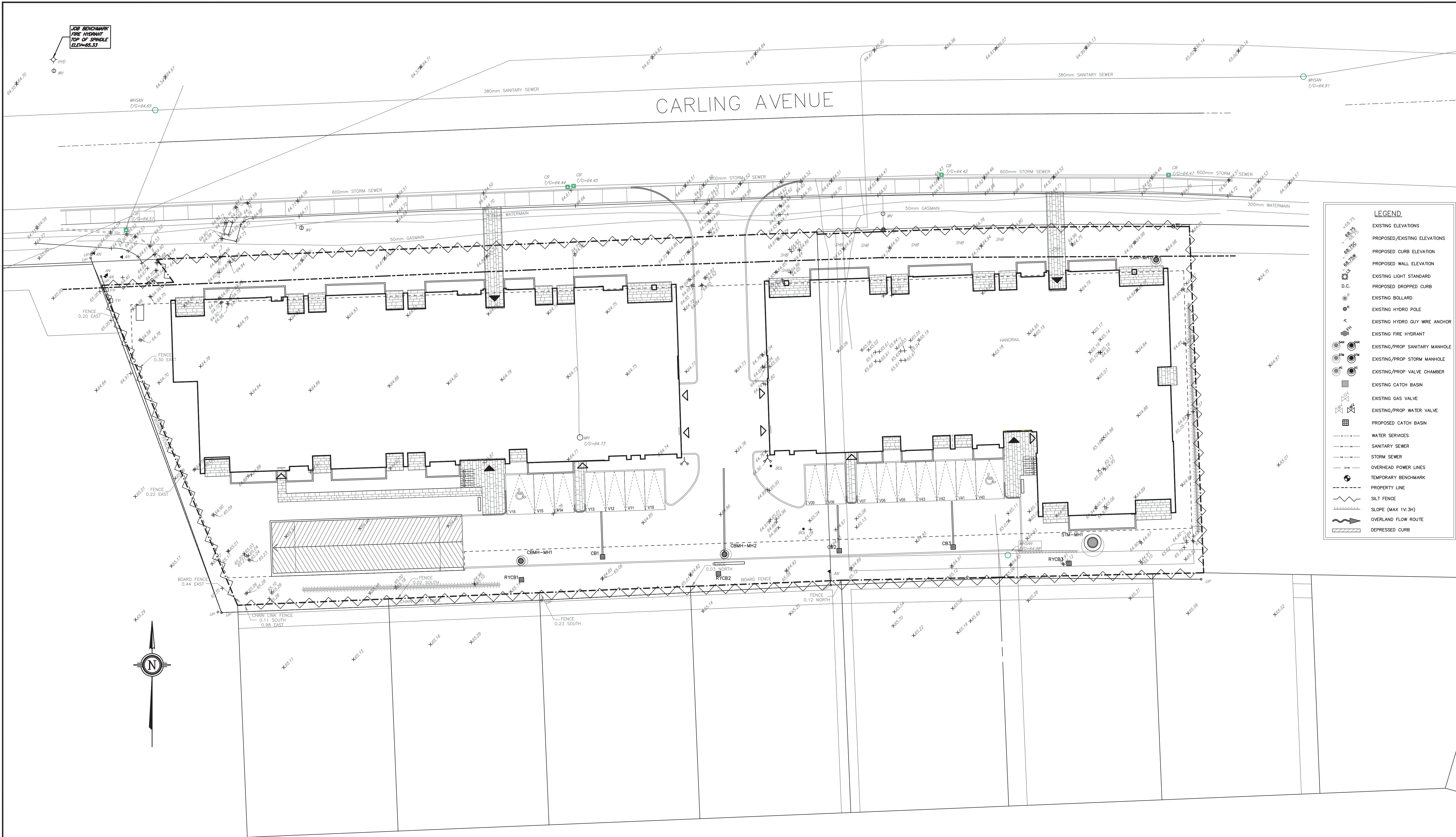

- LEGEND**
- EXISTING ELEVATIONS
 - PROPOSED/EXISTING ELEVATIONS
 - PROPOSED CURB ELEVATION
 - PROPOSED WALL ELEVATION
 - EXISTING LIGHT STANDARD
 - EXISTING DROPPED CURB
 - EXISTING BOLLARD
 - EXISTING HYDRO POLE
 - EXISTING HYDRO GUY WIRE ANCHOR
 - EXISTING FIRE HYDRANT
 - EXISTING/PROP SANITARY MANHOLE
 - EXISTING/PROP STORM MANHOLE
 - EXISTING/PROP VALVE CHAMBER
 - EXISTING CATCH BASIN
 - EXISTING GAS VALVE
 - EXISTING/PROP WATER VALVE
 - PROPOSED CATCH BASIN
 - WATER SERVICES
 - SANITARY SEWER
 - STORM SEWER
 - OVERHEAD POWER LINES
 - TEMPORARY BENCHMARK
 - PROPERTY LINE
 - SILT FENCE
 - SLOPE (MAX 1V:3H)
 - OVERLAND FLOW ROUTE
 - DEPRESSED CURB

- EROSION AND SEDIMENT CONTROL NOTES:**
- THE CONTRACTOR SHALL IMPLEMENT BEST MANAGEMENT PRACTICES, TO PROVIDE FOR PROTECTION OF THE STORM SEWER SYSTEM, DURING CONSTRUCTION ACTIVITIES. THE CONTRACTOR ACKNOWLEDGES THAT FAILURE TO IMPLEMENT APPROPRIATE EROSION AND SEDIMENT CONTROL MEASURES MAY BE SUBJECT TO PENALTIES IMPOSED BY ANY APPLICABLE REGULATORY AGENCY.
 - THE OWNER (AND/OR CONTRACTOR) AGREES TO PREPARE AND IMPLEMENT AN EROSION AND SEDIMENT CONTROL PLAN AT LEAST EQUAL TO THE STATED MINIMUM REQUIREMENTS AND TO THE SATISFACTION OF THE CITY OF OTTAWA, APPROPRIATE TO THE SITE CONDITIONS, PRIOR TO UNDERTAKING ANY SITE ALTERATIONS (FILLING, GRADING, REMOVAL OF VEGETATION, ETC.) AND DURING ALL PHASES OF SITE PREPARATION AND CONSTRUCTION IN ACCORDANCE WITH THE CURRENT BEST MANAGEMENT PRACTICES FOR EROSION AND SEDIMENT CONTROL.
 - THE CONTRACTOR IS TO ENSURE THAT THE SITE ACCESS POINTS AND ADJACENT STREETS TO THE ACCESS POINTS ARE MAINTAINED AND KEPT CLEAN OF CONSTRUCTION MATERIALS SUCH AS, BUT NOT LIMITED TO, MUD, DIRT, CLAY AND GRANULARS ON A DAILY BASIS OR AS NECESSARY, TO THE SATISFACTION OF THE CITY OF OTTAWA.
 - EVERY EFFORT WILL BE MADE TO ENSURE THAT ALL DISTURBED AREAS ARE TOPSOILED AND SEEDED AS SOON AS REASONABLY POSSIBLE.
 - THE SEDIMENT AND EROSION CONTROL PLAN IS A LIVING DOCUMENT WHICH MAY BE AMENDED BY ONSITE REQUIREMENTS AT THE APPROVAL OF THE MUNICIPALITY AND THE CONSERVATION AUTHORITY.
 - ALL SEDIMENT AND EROSION CONTROL MEASURES TO BE INSPECTED/CLEANED AFTER RAIN EVENTS.
 - MUD MAT OR MECHANICAL TRACKOUT PLATE TO BE INSTALLED AT CONSTRUCTION SITE ENTRANCE.
- MINIMUM EROSION AND SEDIMENT CONTROL PLAN REQUIREMENTS:**
- TIME THE DEMOLITION AND EXCAVATION ACTIVITIES SO THAT THEY OCCUR NO SOONER THAN IS NECESSARY FOR SUBSEQUENT CONSTRUCTION ACTIVITIES.
 - LANDSCAPE THE SITE AS SOON AS PRACTICALLY POSSIBLE.
 - USE SILT FENCES AROUND ANY STOCKPILES OF SOIL.
 - PRIOR TO CONSTRUCTION, SILT FENCE BARRIERS (OPSD 219.110) WILL BE PLACED ALONG THE PROPERTY LINES AS ON THE DRAWING.
 - THE SILT FENCE SHOULD BE REMOVED ONLY WHEN THE SITE IS STABILIZED.
 - FILTER SOCKS SHOULD BE INSTALLED ACROSS EXISTING STORM MANHOLE AND CATCH BASIN LIDS, AS WELL, FILTER SOCKS SHOULD BE INSTALLED ACROSS THE PROPOSED CATCH BASIN AND MANHOLE LIDS IMMEDIATELY AFTER THE STRUCTURES ARE PLACED. THE FILTER SOCKS SHOULD ONLY BE REMOVED ONCE THE ASPHALTIC CONCRETE IS INSTALLED AND THE SITE IS CLEANED.

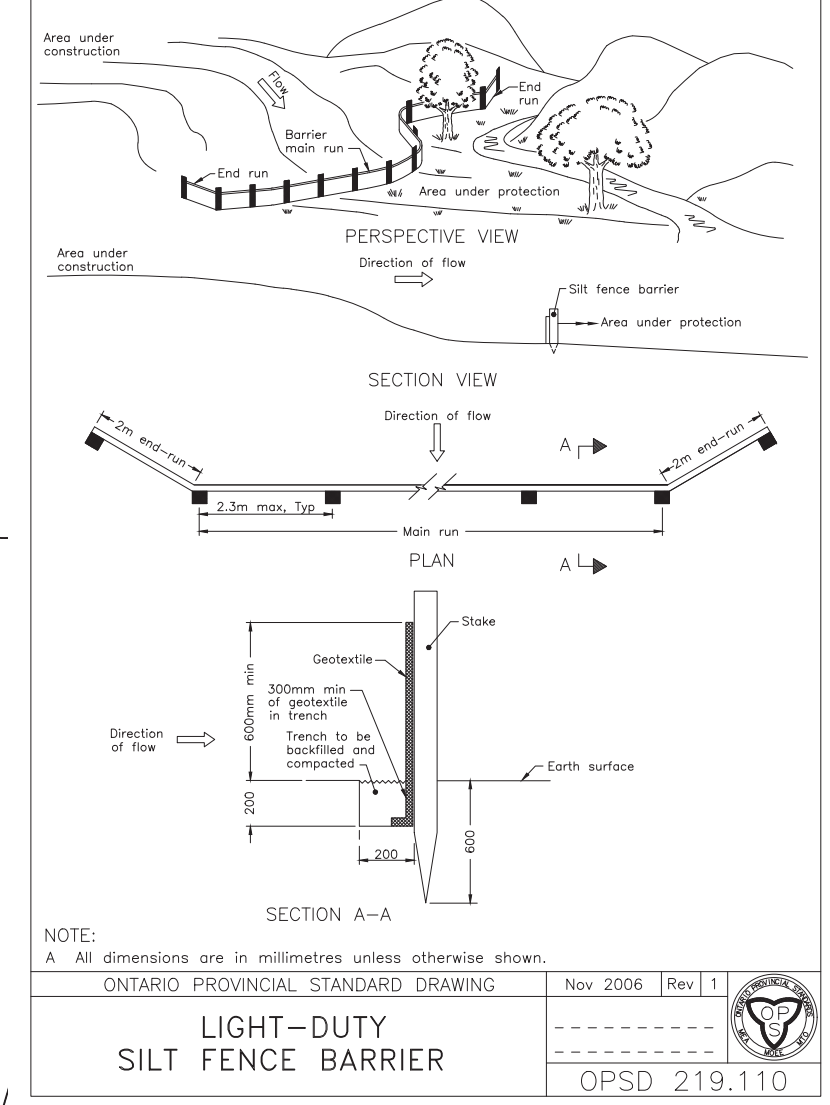

EROSION CONTROL PLAN
SCALE = 1:250

- NOTES:**
- ALL DIMENSIONS ARE IN METRES, UNLESS OTHERWISE SPECIFIED. TOPOGRAPHIC SURVEY WAS PROVIDED BY STANTEC GEOMATICS LTD. TOPOGRAPHIC SURVEY IS GEODETIC AND REFERRED TO THE CVD-1928:1978 GEODETIC DATUM. BEARINGS ARE GRID, DERIVED FROM CAN-NET VRS NETWORK GPS OBSERVATIONS ARE REFERENCED TO SPECIFIED CONTROL POINTS 01919680005 AND 19773035 AND 19680191, MTM ZONE 9 (76°30' WEST LONGITUDE) NAD-83 (ORIGINAL)
 - THIS IS NOT A LEGAL SURVEY.
 - BOUNDARY INFORMATION DERIVED FROM STANTEC GEOMATICS LTD.
 - EXISTING SERVICES INFORMATION SHOWN ARE BASED ON BEST CURRENT INFORMATION. CONTRACTOR TO VERIFY EXACT LOCATION AND REPORT ANY DISCREPANCIES TO KOLLAARD ASSOCIATES INC.
 - CLIENT IS RESPONSIBLE FOR ACQUIRING ALL NECESSARY PERMITS.
 - CONTRACTOR TO VERIFY THAT APPROPRIATE PERMITS HAVE BEEN ACQUIRED PRIOR TO ANY CONSTRUCTION.
 - CONTRACTOR IS RESPONSIBLE FOR LOCATION AND PROTECTION OF UTILITIES.
 - ALL DIMENSIONS TO BE VERIFIED ON SITE BY CONTRACTOR PRIOR TO CONSTRUCTION.
 - THIS DRAWING IS NOT FOR CONSTRUCTION UNTIL ALL APPROVALS HAVE BEEN GRANTED.
 - INSPECTION OF ROUGH GRADE BY KOLLAARD ASSOCIATES INC. AND CITY OF OTTAWA MUST BE CONDUCTED PRIOR TO PLACEMENT OF TOPSOIL OR SO2.
 - HYDRO, GAS, COMMUNICATIONS SERVICE TO BE INSTALLED ACCORDING TO THE SPECIFICATIONS OF SERVICE PROVIDER AND THE MECHANICAL ENGINEER.
 - ALL MATERIALS AND CONSTRUCTION TO BE IN ACCORDANCE WITH CITY OF OTTAWA STANDARDS AND ONTARIO PROVINCIAL STANDARDS AND SPECIFICATIONS.
 - ANY CHANGES MADE TO THIS PLAN MUST BE VERIFIED AND APPROVED BY KOLLAARD ASSOCIATES, INC.
 - THIS DRAWING IS PART OF KOLLAARD ASSOCIATES DESIGN REPORT #220978.

NO.	REVISION	DATE	BY
1	NO CHANGES TO THIS SHEET	28.MAR.2023	NJR
2	ISSUED FOR SITE PLAN CONTROL	14.DEC.2022	NJR

CONSULTANTS

Rohit COMMUNITIES

Kollaard Associates Engineers

BOX 189
210 PRESOTT STREET
KEMPVILLE, ONTARIO
K0G 1J0
FACSIMILE (613) 258-0475

DESIGN: NJR
DRAWN: NJR
CHECKED: SD
APPROVED: SD

STAMP: LICENSED PROFESSIONAL ENGINEER
28.MAR.2023
S.E. deWit
100079612
PROVINCE OF ONTARIO

CLIENT NAME: ROHIT COMMUNITIES INC.	PROJECT No: 220978
PROJECT NAME: PROPOSED RESIDENTIAL DEVELOPMENT	DATE: 14.DEC.2022
PROJECT LOCATION: 3430 CARLING AVENUE, OTTAWA, ONTARIO	SCALE: 1:250
DRAWING: EROSION CONTROL PLAN	DRAWING No: 220978-ER

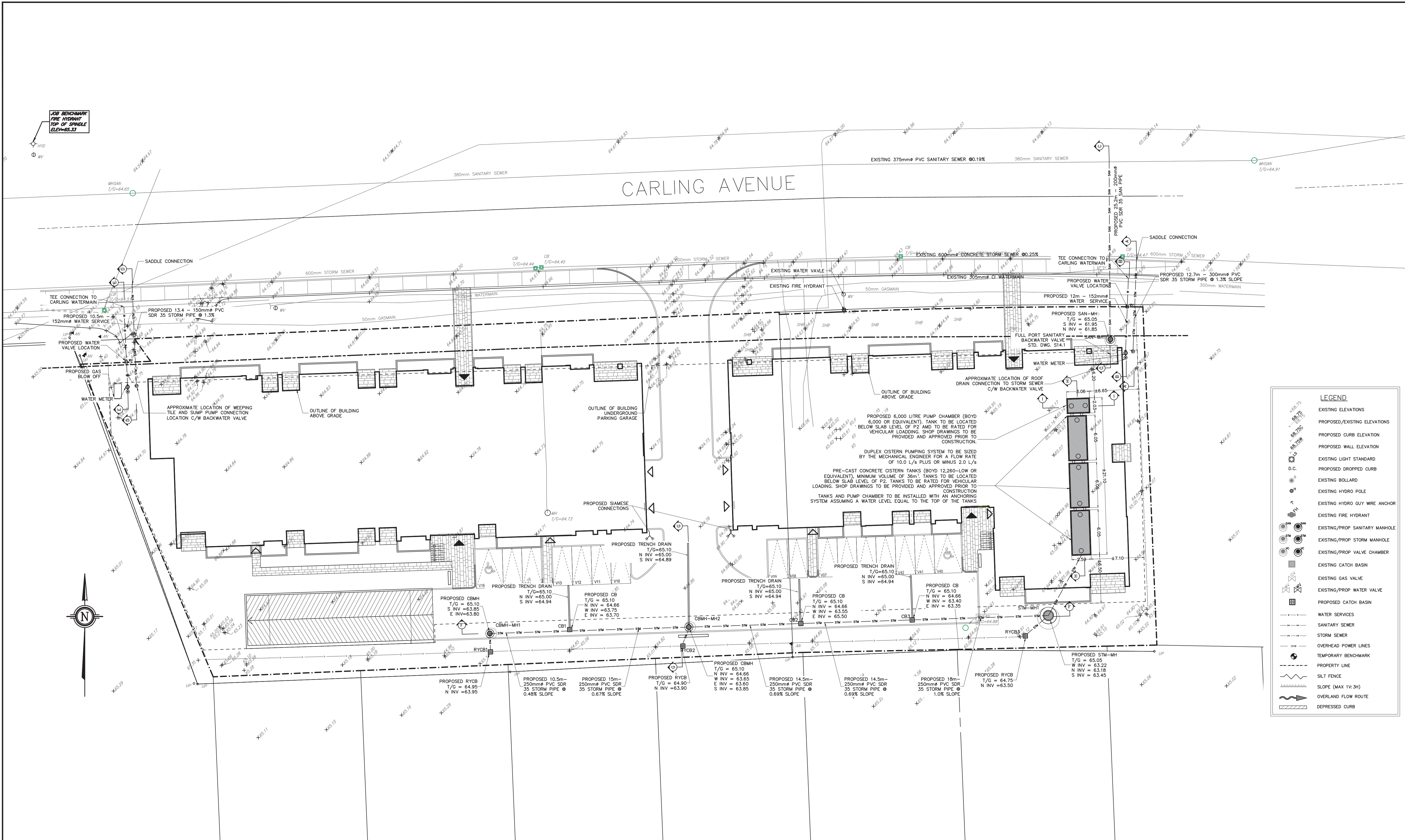
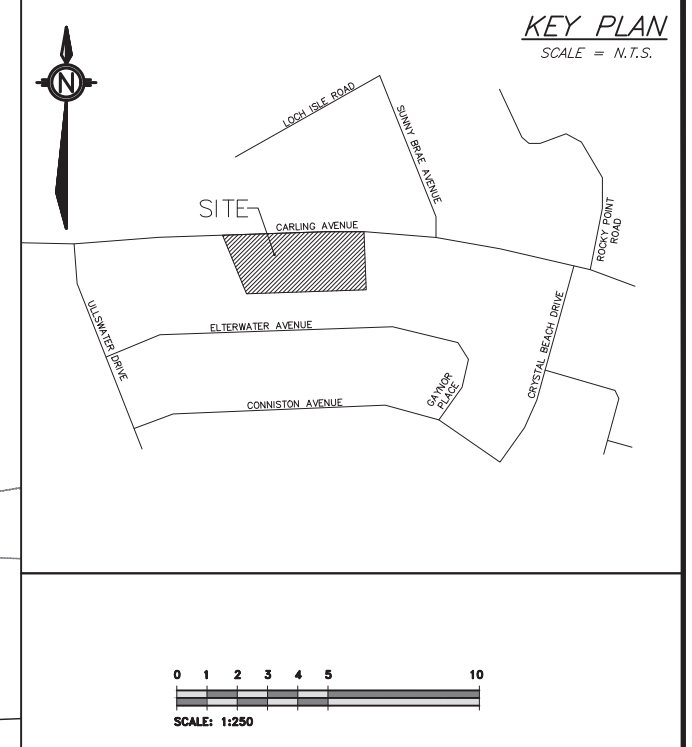

SITE SERVICING PLAN
SCALE = 1:250

SEWER NOTES:

- 1. SUPPLY AND CONSTRUCT ALL SEWERS AND APPURTENANCES IN ACCORDANCE WITH THE CITY OF OTTAWA STANDARDS AND SPECIFICATIONS AND ONTARIO PROVINCIAL STANDARDS FOR ROADS AND PUBLIC WORKS.
2. SPECIFICATIONS:
ITEM SEC. No. CITY STD. DWG. No.
CATCH BASIN (600mm x 600mm) OPSD 705.010 S2
STORM/SANITARY MANHOLE (1000) OPSD 701.021 S11 & S11.1
SEWER SERVICE CONNECTION OPSD 701.021 S11 & S11.1
SEWER BENCHM. OPSD 704.010 S24.1 & S25
CATCH BASIN & MANHOLE ADJUSTMENTS OPSD 704.010 S24.1 & S25
STORM MANHOLE FRAME & COVER OPSD 400.020 S19, S22 & S23
SEWER TRENCH OPSD 400.020 S6 & S7
SANITARY MANHOLE FRAME & COVER OPSD 401.030 S24 & S25
SEWER TRENCH:
SITE SERVICES EXCAVATION, BEDDING & BACKFILL AS PER THE RECOMMENDATIONS OF THE GEOTECHNICAL INVESTIGATION PREPARED BY KOLLAARD ASSOCIATES INC.
3. INSULATE ALL STORM PIPES THAT HAVE LESS THAN 2.0m COVER AND ALL SANITARY PIPES THAT HAVE LESS THAN 2.1m COVER WITH THERMAL INSULATION. PROVIDE 150mm CLEARANCE BETWEEN PIPE AND INSULATION.
4. PIPE BEDDING, COVER AND BACKFILL ARE TO BE COMPACTED TO AT LEAST 90% OF THE STANDARD PROCTOR MAXIMUM DRY DENSITY.
5. FLEXIBLE CONNECTORS ARE REQUIRED FOR CONNECTION PIPES TO MANHOLES (FOR EXAMPLE KOB-H=SEAL, PSC- POSITIVE SEAL, AND DURASEAL). SANITARY RUBBER GASKET TYPE JOINTS SHALL CONFORM TO CSA (B-182.2,3,4).
6. THE OWNER SHALL REQUIRE THAT THE SITE SERVICING CONTRACTOR PERFORM FIELD TESTS FOR QUALITY CONTROL OF ALL SANITARY SEWERS. LEAKAGE TESTING SHALL BE COMPLETED IN ACCORDANCE WITH OPSD 410.07.16, 410.07.16.04 AND 407.07.24. DYE TESTING IS TO BE COMPLETED ON ALL SANITARY SEWERS TO CONFIRM PROPER CONNECTION TO THE SANITARY SEWER MAIN. THE FIELD TESTS SHALL BE PERFORMED IN THE PRESENCE OF A QUALIFIED INSPECTOR WHO SHALL SUBMIT A CERTIFIED COPY OF THE TEST RESULTS.
7. STORM MANHOLES AND CBMS ARE TO HAVE 300mm SLIMPS (AS PER SLIMP DETAIL ON OPSD 701.010), UNLESS OTHERWISE INDICATED.
8. BUILDING CONTRACTOR TO PROVIDE TEMPORARY ADDITIONAL GRANULAR BACKFILL ABOVE SHALLOW CULVERTS AND STORM SEWERS TO SUPPORT HEAVY CONSTRUCTION EQUIPMENT.
9. CONTRACTOR TO TELEVISION (CCTV) ALL PROPOSED SEWERS, 200mm OR GREATER PRIOR TO BASE COURSE ASPHALT. UPON COMPLETION OF CONSTRUCTION THE CONTRACTOR IS RESPONSIBLE TO FLUSH AND CLEAN ALL SEWERS & APPURTENANCES TO MUNICIPAL SATISFACTION.
10. WHERE THE SANITARY SEWER CROSSES ABOVE THE WATERMAIN, THE CONTRACTOR IS TO PROVIDE A MINIMUM OF 0.50m VERTICAL SEPARATION, ADEQUATE STRUCTURAL SUPPORT OF THE SEWER TO PREVENT SETTLING AND EXCESSIVE JOINT DEFLECTION AND ENSURE THAT THE LENGTH OF THE WATER PIPE BE CENTERED AT THE POINT OF CROSSING SO THAT THE JOINTS ARE EQUIVALENT AND AS FAR AS POSSIBLE FROM THE SEWER.
11. MANHOLE IS REQUIRED IF SEWER MAIN IS RIGID MATERIAL.

WATERMAIN NOTES:

- 1. CITY TO SUPPLY, INSTALL & DISINFECT THE WATER SERVICE. CONTRACTOR TO EXCAVATE, BACKFILL AND REINSTATE THE ROADWAY AS PER STD DWG R10.
2. SPECIFICATIONS:
ITEM SEC. No. CITY STD. DWG. No. REFERENCE
WATERMAIN BEDDING AND BACKFILL 802.010/802.031 W17 (trench detail) OPSD
CATHODIC PROTECTION 1109.010 W40 OPSD
PRESSURE TESTING C-605-5 AWWA
CHLORINATION C-651-05 AWWA
WATERMAIN MATERIAL PVC DR18 (CLASS 150)
3. WATERMAIN SHALL BE MINIMUM 2.4m DEPTH BELOW GRADE UNLESS OTHERWISE INDICATED. WHERE LESS THAN 2.4m COVER, THERMAL INSULATION IS TO BE PROVIDED AS PER CITY STD DWG W22 (in shallow trenches), W23 (at open structures).
4. A MINIMUM OF 0.5m VERTICAL CLEARANCE IS REQUIRED BETWEEN THE WATERMANS AND ALL UTILITIES AND SEWERS. IN LOCATIONS WHERE THIS IS NOT ACHIEVABLE, MUST FOLLOW PROCEDURE F-6-1 SEC. 5.2 OF THE ONTARIO DRINKING WATER RESOURCES ACT.
5. METALLIC WARNING TAPE SHALL BE USED OVER ALL WATERMANS.
6. INSTALL AND TEST TRACER WIRE FOR ALL PROPOSED WATERMAIN IN ACCORDANCE WITH THE CITY OF OTTAWA DESIGN STANDARDS AS SPECIFIED IN SECTION 8.28.
7. EXISTING WATERMAIN INFORMATION SHOWN ON CARLING AVENUE IS BASED ON BEST CURRENT INFORMATION. CONTRACTOR TO VERIFY EXACT LOCATION OF WATERMAIN AND REPORT ANY DISCREPANCIES TO KOLLAARD ASSOCIATES INC.
8. CONNECTIONS AT ELBOWS AND TEES IN WATER MAINS SHOULD BE MADE WITH THE USE OF JOINT RESTRAINERS DESIGNED FOR WATERMAIN APPLICATION. JOINT AND PIPE RESTRAINERS SHOULD MEET THE REQUIREMENTS OF AWWA C900, C905 AND ASTM F1874-11. JOINT RESTRAINERS SHOULD BE INSTALLED AS PER MANUFACTURERS RECOMMENDATIONS.
9. ALL CONNECTORS, RODS AND VALVE BOLTS SHALL BE STAINLESS STEEL.
10. VALVES ARE TO BE OPERATED BY CITY OF OTTAWA STAFF ONLY.
11. NO CONNECTION TO EXISTING WATER NETWORK SHALL BE COMPLETED UNTIL A WATER PERMIT IS OBTAINED FROM THE CITY OF OTTAWA AND CITY OF OTTAWA FORCES ARE ON HAND TO MAKE THE CONNECTION.

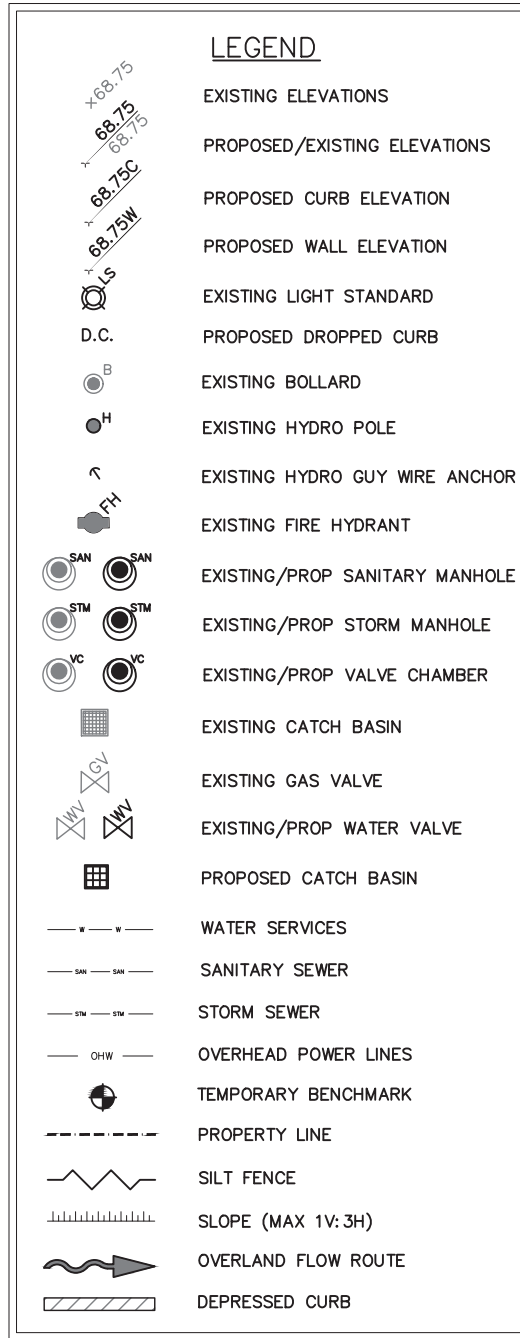

NOTES:
1. ALL DIMENSIONS ARE IN METRES, UNLESS OTHERWISE SPECIFIED. TOPOGRAPHIC SURVEY WAS PROVIDED BY STANTEC GEOMATICS LTD. TOPOGRAPHIC SURVEY IS GEODETIC AND REFERRED TO THE CGVD-1928/1978 GEODETIC DATUM. BEARINGS ARE GRID, DERIVED FROM CAN-NET VRS NETWORK. GPS OBSERVATIONS ARE REFERENCED TO SPECIFIED CONTROL POINTS 01919680005 AND 19773035 AND 19680191, MTM ZONE 9 (76°30' WEST LONGITUDE) NAD-83 (ORIGINAL).
2. THIS IS NOT A LEGAL SURVEY.
3. BOUNDARY INFORMATION DERIVED FROM STANTEC GEOMATICS LTD.
4. EXISTING SERVICES INFORMATION SHOWN ARE BASED ON BEST CURRENT INFORMATION. CONTRACTOR TO VERIFY EXACT LOCATION AND REPORT ANY DISCREPANCIES TO KOLLAARD ASSOCIATES INC.
5. CLIENT IS RESPONSIBLE FOR ACQUIRING ALL NECESSARY PERMITS.
6. CONTRACTOR TO VERIFY THAT APPROPRIATE PERMITS HAVE BEEN ACQUIRED PRIOR TO ANY CONSTRUCTION.

7. CONTRACTOR IS RESPONSIBLE FOR LOCATION AND PROTECTION OF UTILITIES.
8. ALL DIMENSIONS TO BE VERIFIED ON SITE BY CONTRACTOR PRIOR TO CONSTRUCTION.
9. THIS DRAWING IS NOT FOR CONSTRUCTION UNTIL ALL APPROVALS HAVE BEEN GRANTED.
10. INSPECTION OF ROUGH GRADE BY KOLLAARD ASSOCIATES INC. AND CITY OF OTTAWA MUST BE CONDUCTED PRIOR TO PLACEMENT OF TOPSOIL OR SOD.
11. HYDRO, GAS, COMMUNICATIONS SERVICE TO BE INSTALLED ACCORDING TO THE SPECIFICATIONS OF SERVICE PROVIDER AND THE MECHANICAL ENGINEER.
12. ALL MATERIALS AND CONSTRUCTION TO BE IN ACCORDANCE WITH CITY OF OTTAWA STANDARDS AND ONTARIO PROVINCIAL STANDARDS AND SPECIFICATIONS.
13. ANY CHANGES MADE TO THIS PLAN MUST BE VERIFIED AND APPROVED BY KOLLAARD ASSOCIATES, INC.
14. THIS DRAWING IS PART OF KOLLAARD ASSOCIATES DESIGN REPORT #220978.

Table with 4 columns: No., REVISION, DATE, BY. Contains two entries for revisions.

CONSULTANTS section featuring Rohit Communities logo and contact information.

Kollaard Associates Engineers logo and contact information.

Professional Engineer stamp for S.E. deWit, dated 28 MAR 2023.

Project information table including Client Name (ROHIT COMMUNITIES INC.), Project Name (PROPOSED RESIDENTIAL DEVELOPMENT), Project Location (3430 CARLING AVENUE, OTTAWA, ONTARIO), and Drawing No. (220978 - SER).

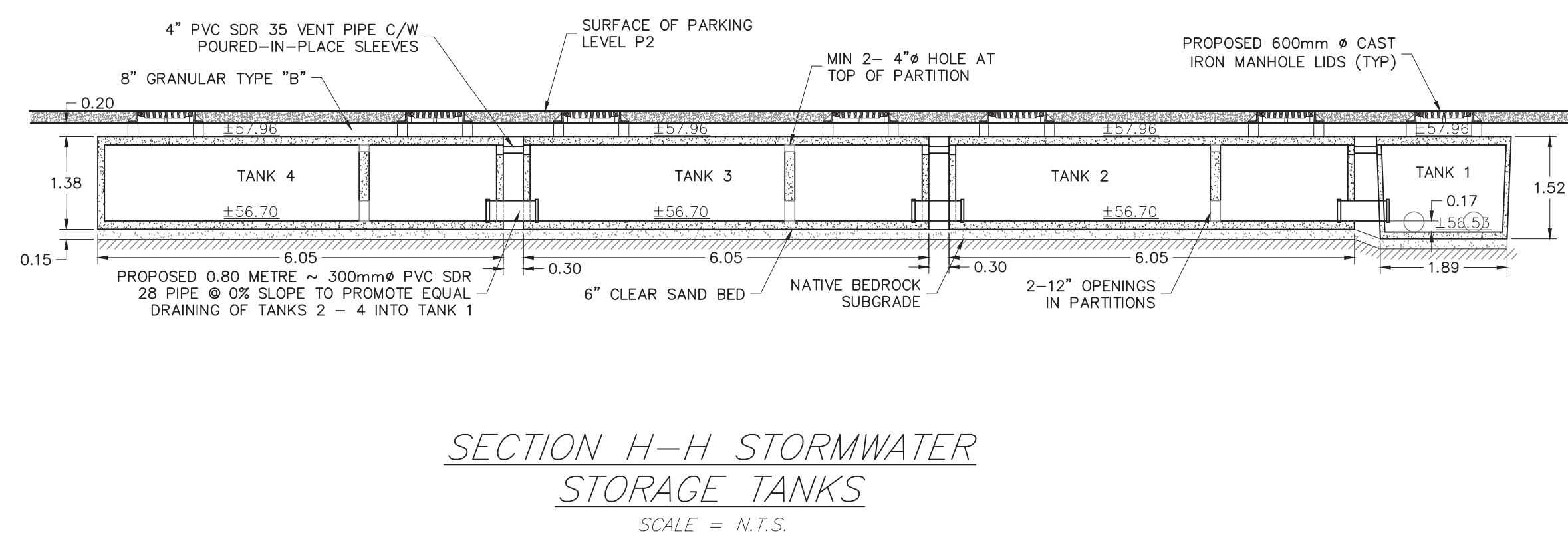
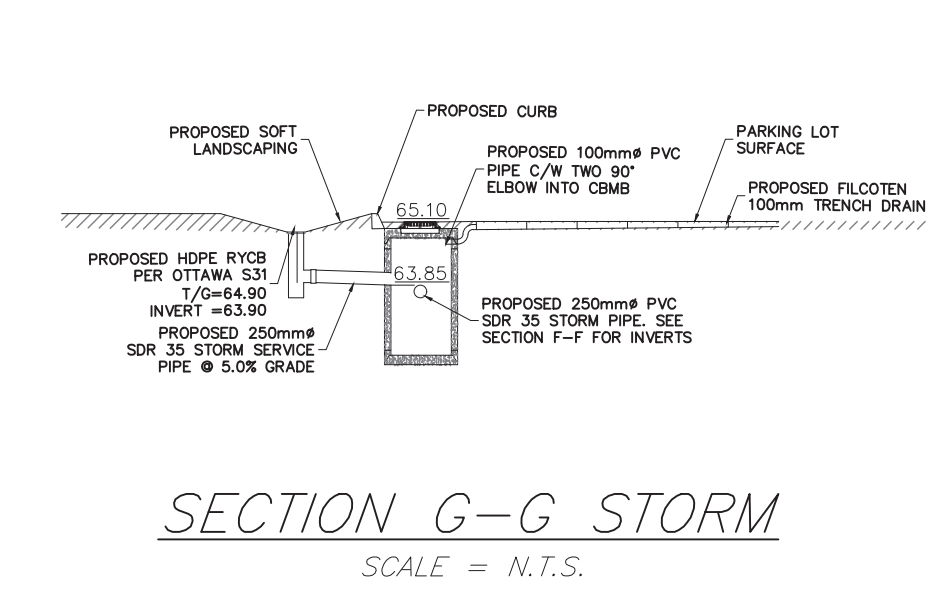
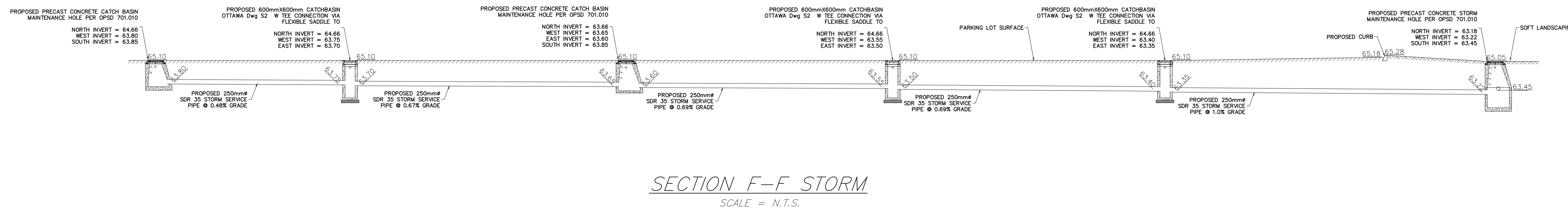
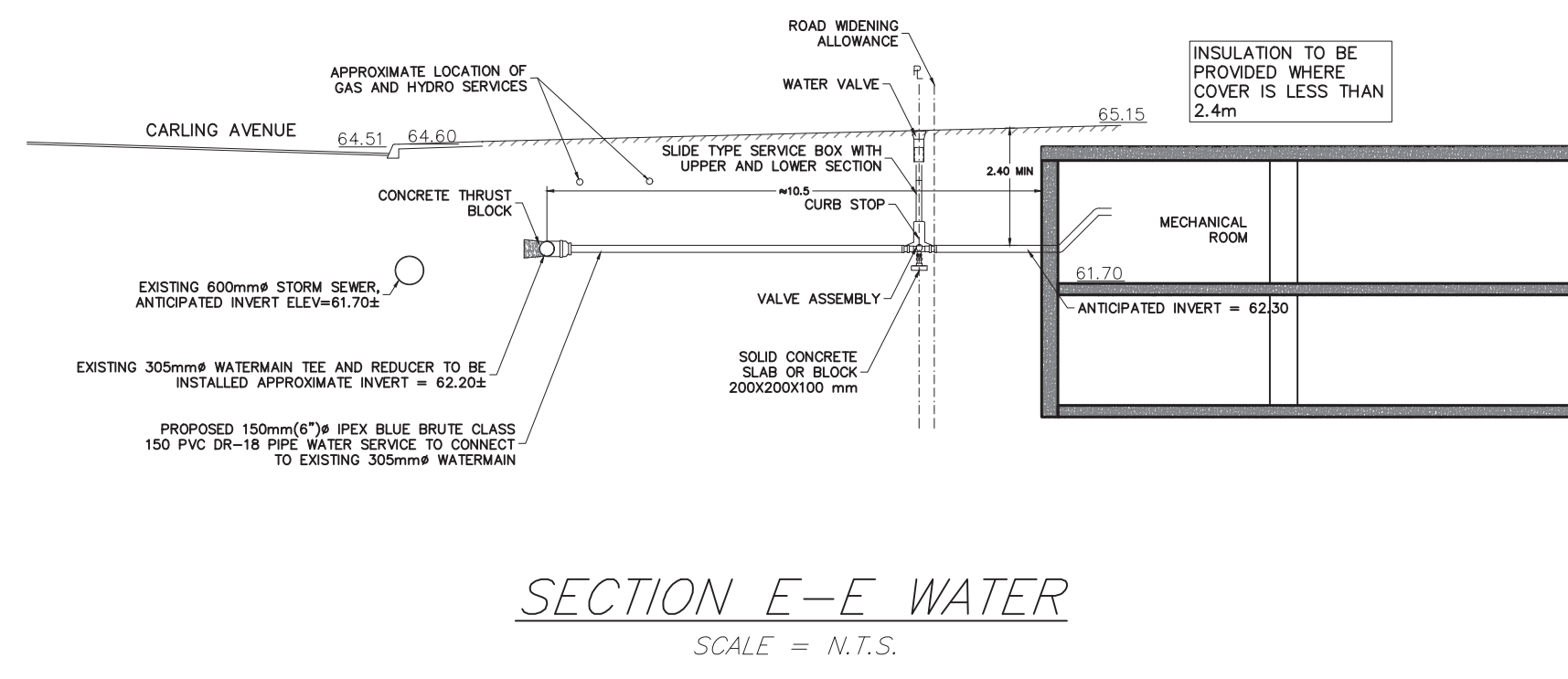
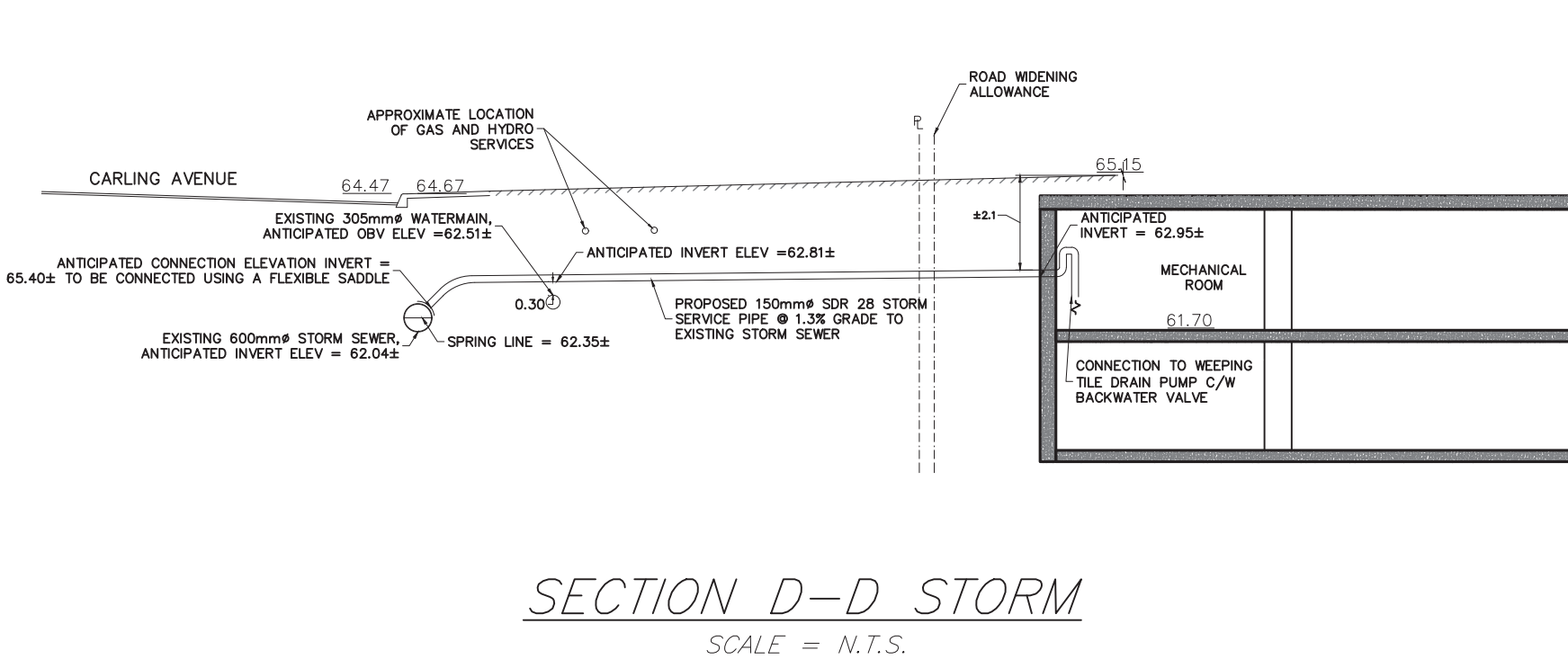
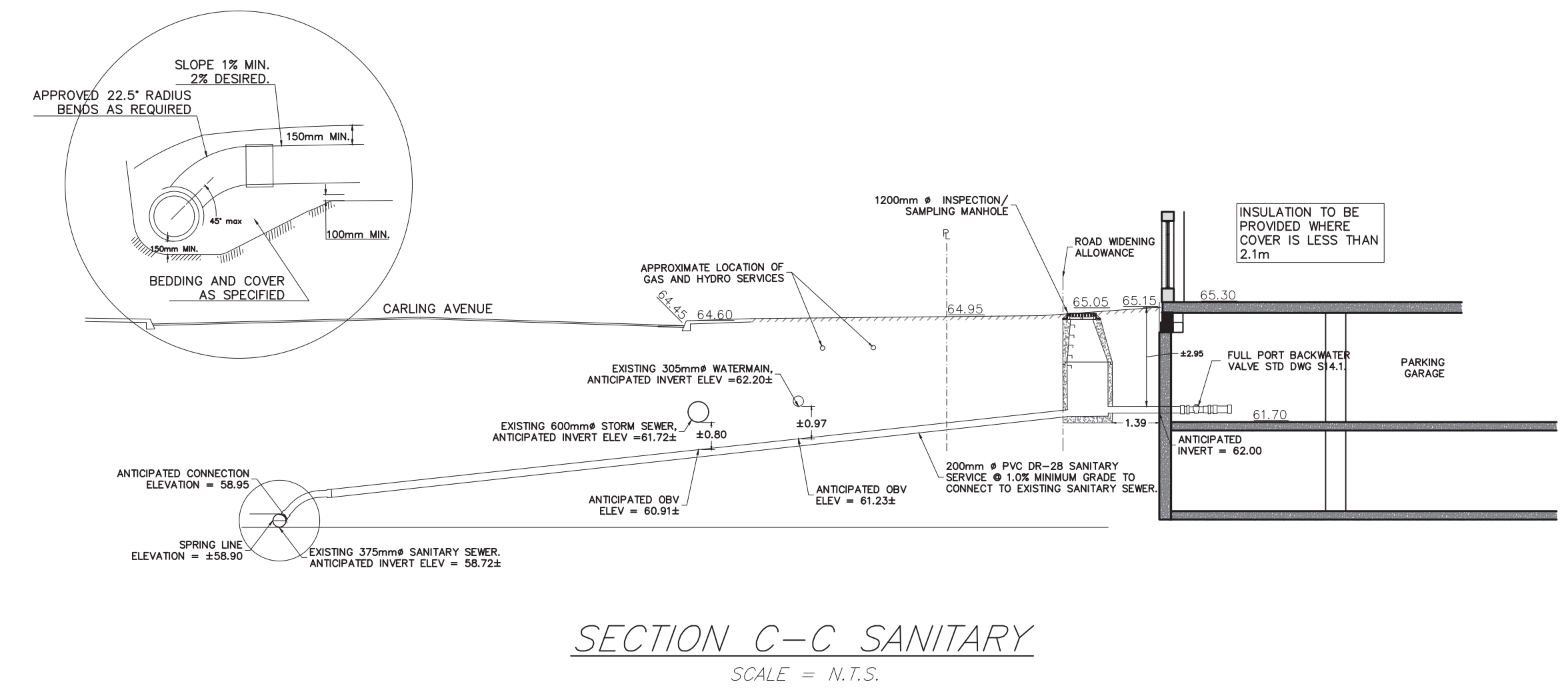
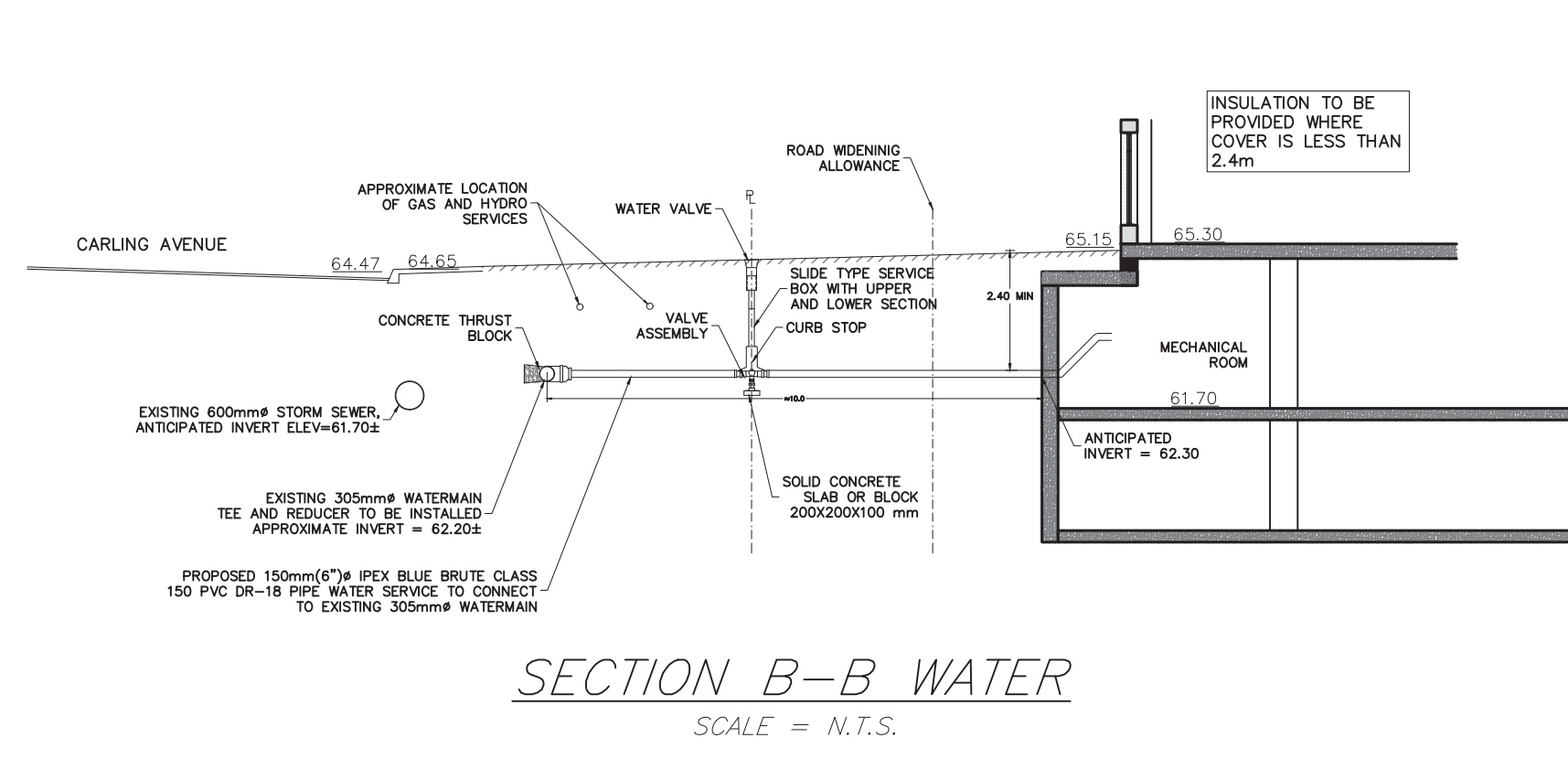
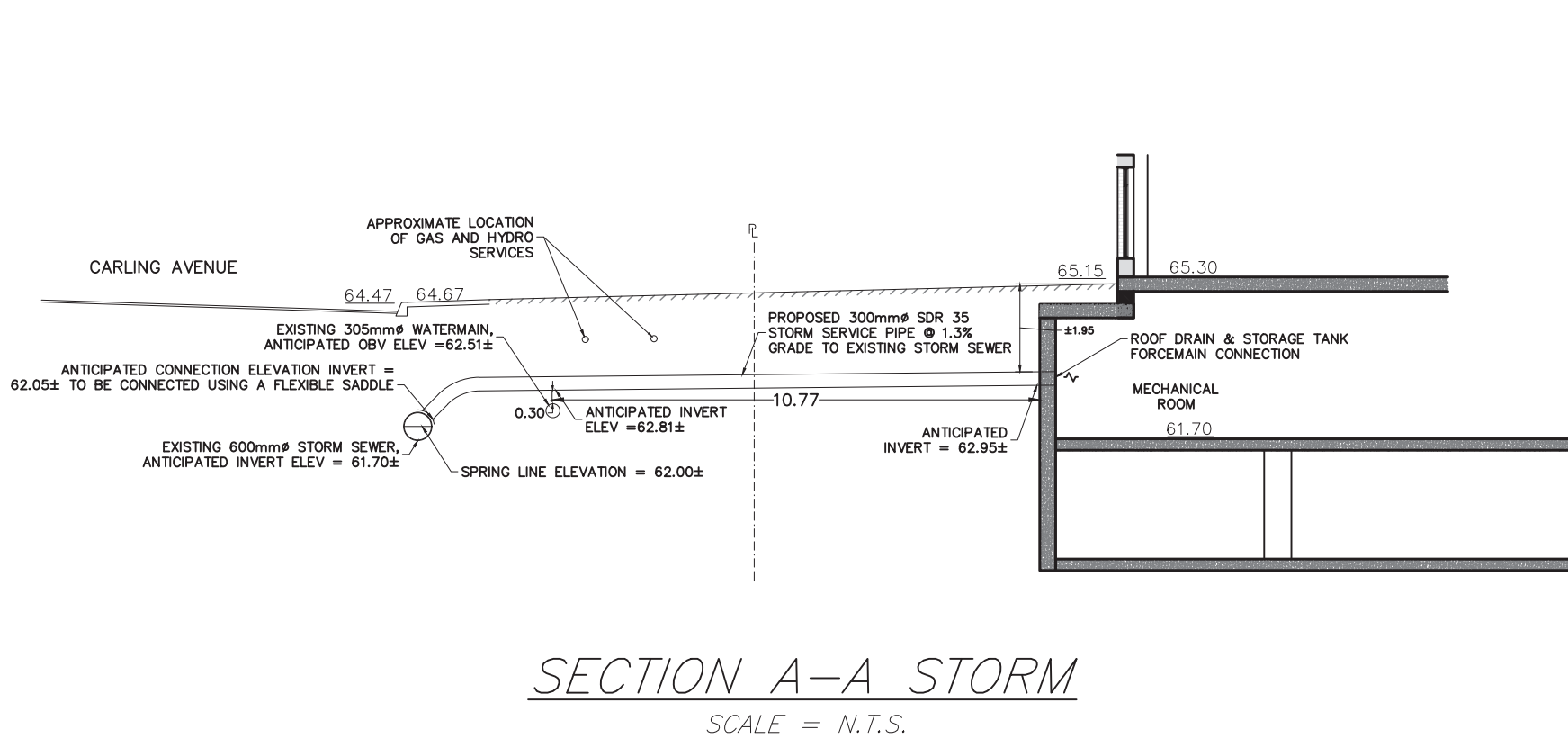

NOTE:
STORAGE TANKS TO BE VEHICULAR RATED FOR PLACEMENT UNDER THE PARKING SLAB. SHOP DRAWINGS TO BE PROVIDED TO THE ENGINEER PRIOR TO CONSTRUCTION

STORAGE TANKS: BOYD BRO'S
12,265L LB-2 COMPARTMENT SEPTIC TANK
SERIES NO. BigBlue
MODEL NO. 12
REV. 5.0

PUMP TANK: BOYD BRO'S
5,000 - 2 COMPARTMENT SEPTIC TANK
SERIES NO. 6000
MODEL NO. 6000R
REV. 6.0

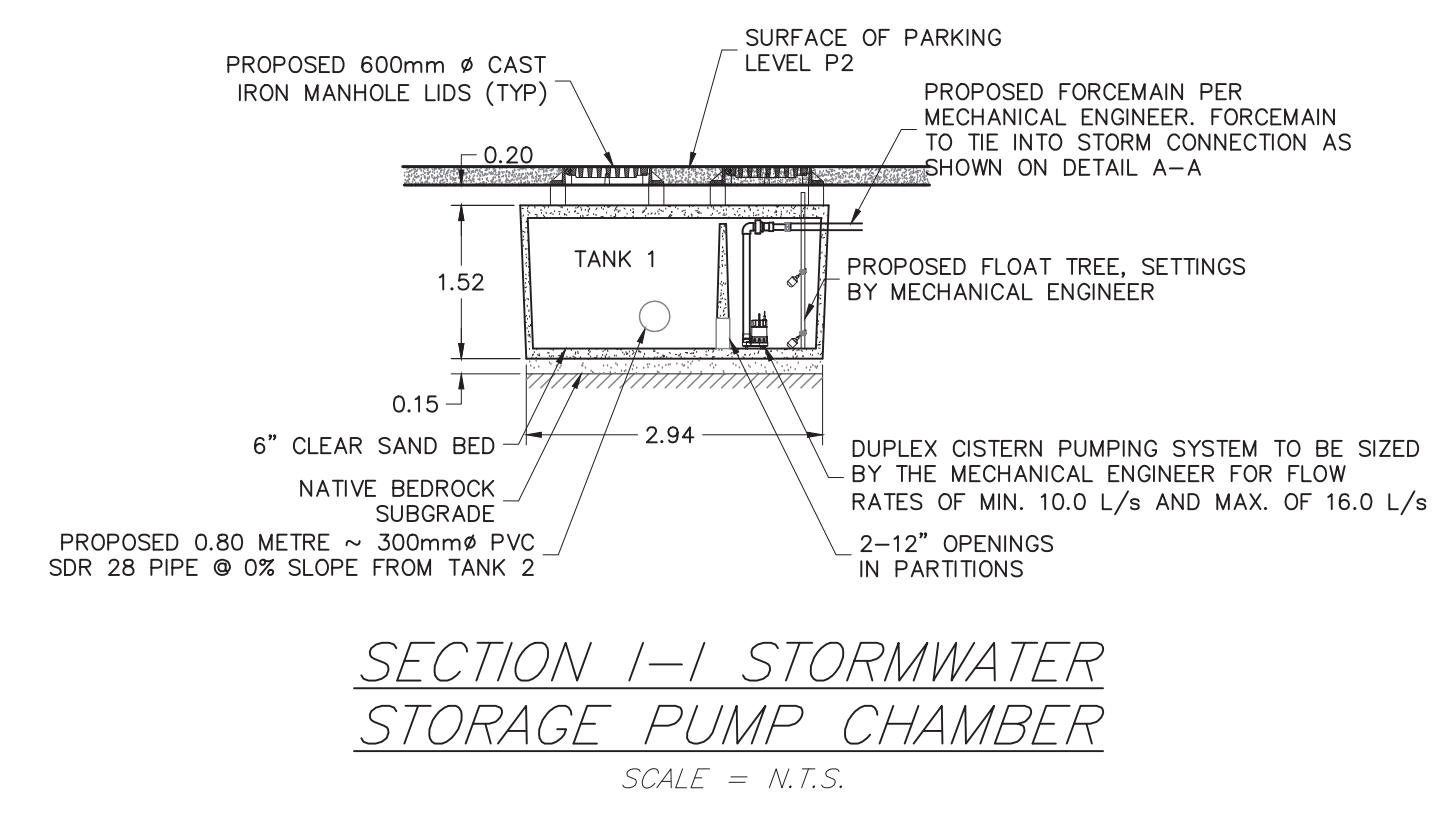

- NOTES:
- ALL DIMENSIONS ARE IN METRES, UNLESS OTHERWISE SPECIFIED. TOPOGRAPHIC SURVEY WAS PROVIDED BY STANTEC GEOMATICS LTD. TOPOGRAPHIC SURVEY IS GEODETIC AND REFERRED TO THE CGVD-1928:1978 GEODETIC DATUM. BEARINGS ARE GRID, DERIVED FROM CAN-NET VRS NETWORK. GPS OBSERVATIONS ARE REFERENCED TO SPECIFIED CONTROL POINTS 01919680005 AND 19773035 AND 19680191, MTM ZONE 9 (76°30' WEST LONGITUDE) NAD-83 (ORIGINAL)
 - THIS IS NOT A LEGAL SURVEY.
 - BOUNDARY INFORMATION DERIVED FROM STANTEC GEOMATICS LTD. CONTRACTOR TO VERIFY EXACT LOCATION AND REPORT ANY DISCREPANCIES TO KOLLAARD ASSOCIATES INC.
 - CLIENT IS RESPONSIBLE FOR ACQUIRING ALL NECESSARY PERMITS.
 - CONTRACTOR TO VERIFY THAT APPROPRIATE PERMITS HAVE BEEN ACQUIRED PRIOR TO ANY CONSTRUCTION.
 - CONTRACTOR IS RESPONSIBLE FOR LOCATION AND PROTECTION OF UTILITIES.
 - ALL DIMENSIONS TO BE VERIFIED ON SITE BY CONTRACTOR PRIOR TO CONSTRUCTION.
 - THIS DRAWING IS NOT FOR CONSTRUCTION UNTIL ALL APPROVALS HAVE BEEN GRANTED.
 - INSPECTION OF ROUGH GRADE BY KOLLAARD ASSOCIATES INC. AND CITY OF OTTAWA MUST BE CONDUCTED PRIOR TO PLACEMENT OF TOPSOIL OR SOIL.
 - HYDRO, GAS, COMMUNICATIONS SERVICE TO BE INSTALLED ACCORDING TO THE SPECIFICATIONS OF SERVICE PROVIDER AND THE MECHANICAL ENGINEER.
 - ALL MATERIALS AND CONSTRUCTION TO BE IN ACCORDANCE WITH CITY OF OTTAWA STANDARDS AND ONTARIO PROVINCIAL STANDARDS AND SPECIFICATIONS.
 - ANY CHANGES MADE TO THIS PLAN MUST BE VERIFIED AND APPROVED BY KOLLAARD ASSOCIATES, INC.
 - THIS DRAWING IS PART OF KOLLAARD ASSOCIATES DESIGN REPORT #220978.

NO.	REVISION	DATE	BY
1	RESPONSE TO 1ST REVIEW COMMENTS	28.MAR.2023	NJR
2	ISSUED FOR SITE PLAN CONTROL	14.DEC.2022	NJR

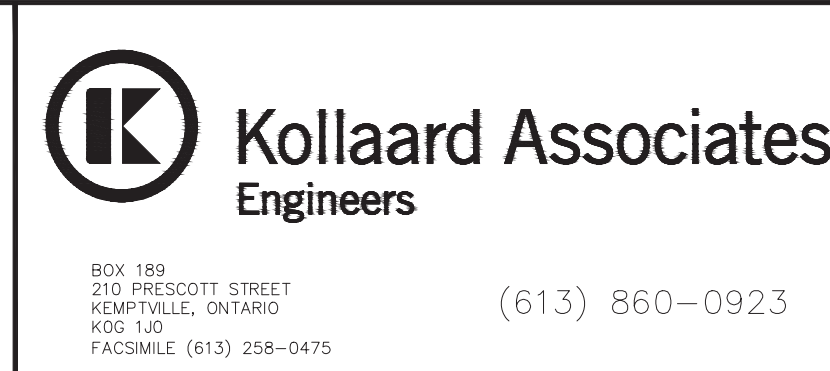

DESIGN	NJR
DRAWN	NJR
CHECKED	SD
APPROVED	SD

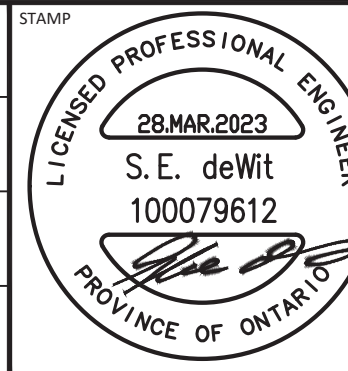

CLIENT NAME	ROHIT COMMUNITIES INC.	PROJECT NO.	220978
PROJECT NAME	PROPOSED RESIDENTIAL DEVELOPMENT	DATE	14.DEC.2022
PROJECT LOCATION	3430 CARLING AVENUE, OTTAWA, ONTARIO	SCALE	N.T.S.
DRAWING	SITE SERVICING DETAILS	DRAWING NO.	220978 - DET

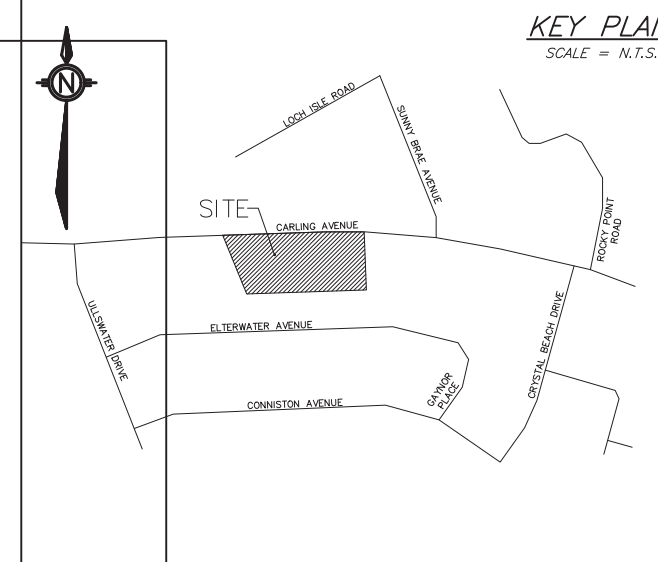

CARLING AVENUE

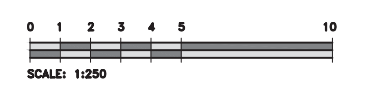
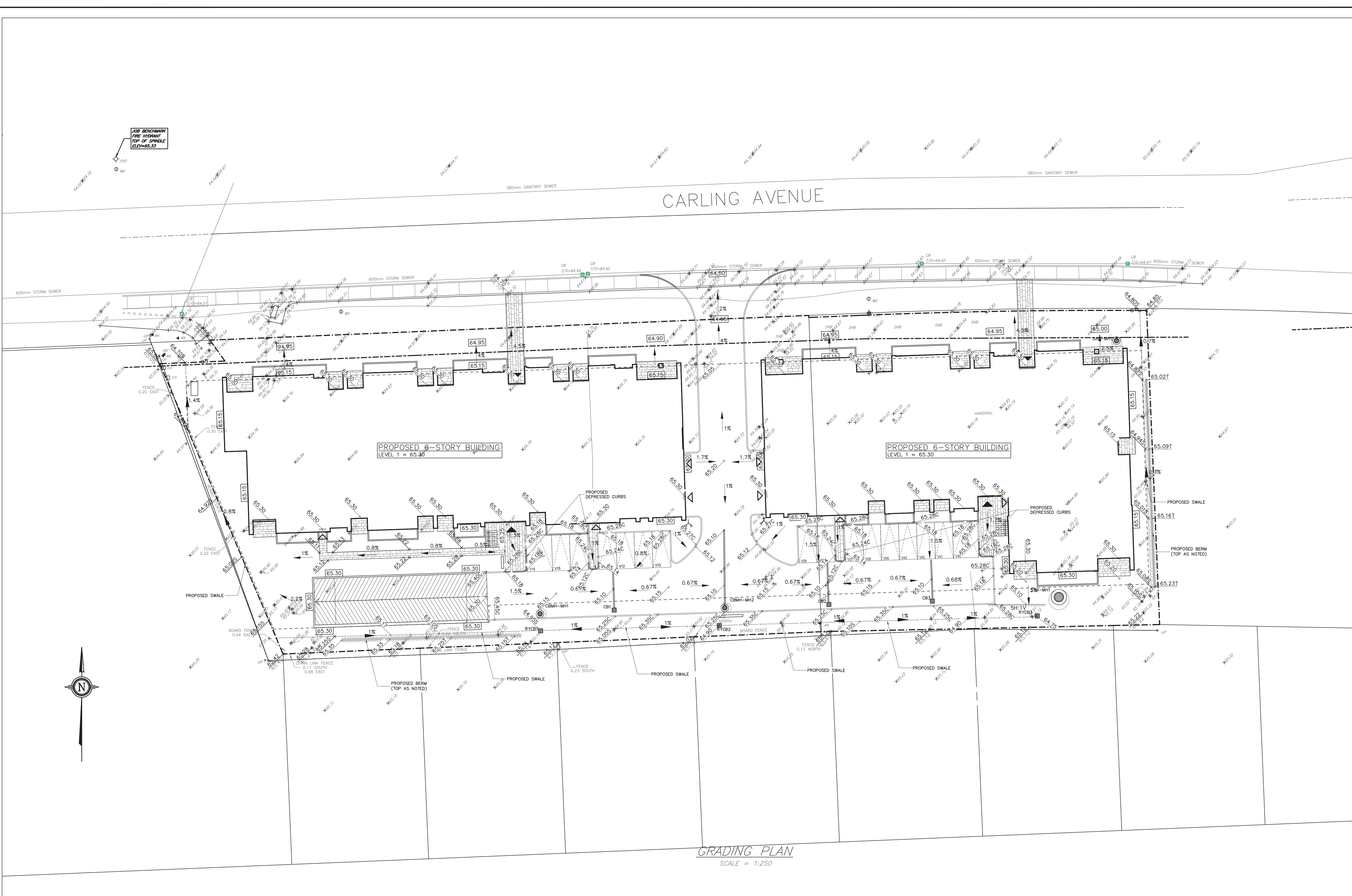

LEGEND

- EXISTING ELEVATIONS
- PROPOSED/EXISTING ELEVATIONS
- PROPOSED CURB ELEVATION
- PROPOSED WALL ELEVATION
- EXISTING LIGHT STANDARD
- PROPOSED DROPPED CURB
- EXISTING BOLLARD
- EXISTING HYDRO POLE
- EXISTING HYDRO GUY WIRE ANCHOR
- EXISTING FIRE HYDRANT
- EXISTING/PROP SANITARY MANHOLE
- EXISTING/PROP STORM MANHOLE
- EXISTING/PROP VALVE CHAMBER
- EXISTING CATCH BASIN
- EXISTING GAS VALVE
- EXISTING/PROP WATER VALVE
- PROPOSED CATCH BASIN
- WATER SERVICES
- SANITARY SEWER
- STORM SEWER
- OVERHEAD POWER LINES
- TEMPORARY BENCHMARK
- PROPERTY LINE
- SILT FENCE
- SLOPE (MAX 1V:3H)
- OVERLAND FLOW ROUTE
- DEPRESSED CURB

GRADING PLAN
SCALE = 1:250

NOTES:

- ALL DIMENSIONS ARE IN METRES, UNLESS OTHERWISE SPECIFIED. TOPOGRAPHIC SURVEY WAS PROVIDED BY STANTEC GEOMATICS LTD. TOPOGRAPHIC SURVEY IS GEODETIC AND REFERRED TO THE CGVD-1928/1978 GEODETIC DATUM. BEARINGS ARE GRID, DERIVED FROM CAN-NET VRS NETWORK. GPS OBSERVATIONS ARE REFERENCED TO SPECIFIED CONTROL POINTS 01919680005 AND 19773035 AND 19680191, MTM ZONE 9 (76°30' WEST LONGITUDE) NAD-83 (ORIGINAL)
- THIS IS NOT A LEGAL SURVEY.
- BOUNDARY INFORMATION DERIVED FROM STANTEC GEOMATICS LTD.
- EXISTING SERVICES INFORMATION SHOWN ARE BASED ON BEST CURRENT INFORMATION. CONTRACTOR TO VERIFY EXACT LOCATION AND REPORT ANY DISCREPANCIES TO KOLLAARD ASSOCIATES INC.
- CLIENT IS RESPONSIBLE FOR ACQUIRING ALL NECESSARY PERMITS.
- CONTRACTOR TO VERIFY THAT APPROPRIATE PERMITS HAVE BEEN ACQUIRED PRIOR TO ANY CONSTRUCTION.
- CONTRACTOR IS RESPONSIBLE FOR LOCATION AND PROTECTION OF UTILITIES.
- ALL DIMENSIONS TO BE VERIFIED ON SITE BY CONTRACTOR PRIOR TO CONSTRUCTION.
- THIS DRAWING IS NOT FOR CONSTRUCTION UNTIL ALL APPROVALS HAVE BEEN GRANTED.
- INSPECTION OF ROUGH GRADE BY KOLLAARD ASSOCIATES INC. AND CITY OF OTTAWA MUST BE CONDUCTED PRIOR TO PLACEMENT OF TOPSOIL OR SOD.
- HYDRO, GAS, COMMUNICATIONS SERVICE TO BE INSTALLED ACCORDING TO THE SPECIFICATIONS OF SERVICE PROVIDER AND THE MECHANICAL ENGINEER.
- ALL MATERIALS AND CONSTRUCTION TO BE IN ACCORDANCE WITH CITY OF OTTAWA STANDARDS AND ONTARIO PROVINCIAL STANDARDS AND SPECIFICATIONS.
- ANY CHANGES MADE TO THIS PLAN MUST BE VERIFIED AND APPROVED BY KOLLAARD ASSOCIATES, INC.
- THIS DRAWING IS PART OF KOLLAARD ASSOCIATES DESIGN REPORT #220978.

NO.	REVISION	DATE	BY
1	RESPONSE TO 1ST REVIEW COMMENTS	28 MAR. 2023	NJR
2	ISSUED FOR SITE PLAN CONTROL	14 DEC. 2022	NJR

CONSULTANTS

Kollaard Associates
Engineers

BOX 189
210 PRESOTT STREET
KEMPVILLE, ONTARIO
K0G 1J0
FACSIMILE (613) 258-0475

(613) 860-0923

DESIGN	NJR
DRAWN	NJR
CHECKED	SD
APPROVED	SD



CLIENT NAME	ROHIT COMMUNITIES INC.
PROJECT NAME	PROPOSED RESIDENTIAL DEVELOPMENT
PROJECT LOCATION	3430 CARLING AVENUE, OTTAWA, ONTARIO
DRAWING	GRADING PLAN

PROJECT No.	220978
DATE	14 DEC. 2022
SCALE	1:250
DRAWING No.	220978 - GR