

**PROPOSED RESIDENTIAL DEVELOPMENT  
1765 MONTREAL ROAD**

**DEVELOPMENT SERVICING AND  
STORMWATER MANAGEMENT REPORT**

Prepared by:

**NOVATECH**

Suite 200, 240 Michael Cowpland Drive  
Kanata, Ontario  
K2M 1P6

December 20, 2022

Ref: R-2022-206  
Novatech File No. 121060

December 20, 2022

Landric Homes  
63 Montréal Road E  
Gatineau, Quebec  
J8M 1K3

**Attention: Mr. Eric Danis**

Dear Sir:

**Re: Development Servicing and Stormwater Management Report  
Proposed Residential Development  
1765 Montreal Road, Ottawa, Ontario  
Novatech File No: 121060**

---

Enclosed is a copy of the revised 'Development Servicing and Stormwater Management Report' for the proposed residential development located at 1765 Montreal Road, in the City of Ottawa. This report addresses the approach to site servicing and stormwater management and is submitted in support of a zoning by-law amendment and site plan control application.

Please contact the undersigned, should you have any questions or require additional information.

Yours truly,

**NOVATECH**



Miroslav Savic, P. Eng.  
Senior Project Manager

cc: Rubina Rasool (City of Ottawa)  
Ryan Koolwine (project1studio)

## TABLE OF CONTENTS

<b>1.0</b>	<b>INTRODUCTION</b> .....	<b>1</b>
1.1	<b>Site Description and Location</b> .....	<b>1</b>
1.2	<b>Pre-Consultation Information</b> .....	<b>1</b>
1.3	<b>Proposed Development</b> .....	<b>2</b>
1.4	<b>Reference Material</b> .....	<b>2</b>
<b>2.0</b>	<b>SITE SERVICING</b> .....	<b>2</b>
2.1	<b>Sanitary Sewage</b> .....	<b>2</b>
2.1.1	<b>Sanitary Pump Station</b> .....	<b>3</b>
2.2	<b>Water</b>	
2.2.1	<b>Domestic Water Demands and Watermain Analysis</b> .....	<b>4</b>
2.2.2	<b>Water Supply for Fire-Fighting</b> .....	<b>5</b>
2.3	<b>Storm Drainage and Stormwater Management</b> .....	<b>6</b>
2.3.1	<b>Stormwater Management Criteria and Objectives</b> .....	<b>6</b>
2.3.2	<b>Pre-Development Conditions and Allowable Release Rate</b> .....	<b>6</b>
2.3.3	<b>Post-Development Conditions</b> .....	<b>7</b>
2.3.3.1	<b>Area A-1: Uncontrolled Direct Runoff to Montreal Road</b> .....	<b>7</b>
2.3.3.2	<b>Area A-2: Uncontrolled Direct Runoff to Cedar Road</b> .....	<b>7</b>
2.3.3.3	<b>Area A-3: Controlled Flow – Townhouse Roof (North-West)</b> .....	<b>7</b>
2.3.3.4	<b>Area A-4: Controlled Flow – Townhouse Roof (North-East)</b> .....	<b>8</b>
2.3.3.5	<b>Area A-5: Controlled Flow – 9-Storey Building Roof</b> .....	<b>9</b>
2.3.3.6	<b>Area A-6: Uncontrolled Flow to Cedar Road</b> .....	<b>10</b>
2.3.3.7	<b>Area A-7: Controlled Flow from Internal SWM Tank</b> .....	<b>10</b>
2.3.4	<b>Stormwater Flow Summary</b> .....	<b>11</b>
2.4	<b>Stormwater Quality Control</b> .....	<b>11</b>
<b>3.0</b>	<b>SITE GRADING</b> .....	<b>12</b>
3.1	<b>Emergency Overland Flow Route</b> .....	<b>12</b>
<b>4.0</b>	<b>GEOTECHNICAL INVESTIGATIONS</b> .....	<b>12</b>
<b>5.0</b>	<b>EROSION AND SEDIMENT CONTROL</b> .....	<b>12</b>
<b>6.0</b>	<b>CONCLUSION</b> .....	<b>13</b>

## **LIST OF FIGURES**

Figure 1 Aerial Plan

## **LIST OF APPENDICES**

Appendix A: Correspondence

Appendix B: Development Servicing Study Checklist

Appendix C: Sanitary Flow Calculations

Appendix D: Water Demands, FUS Calculations and City of Ottawa Boundary Conditions

Appendix E: IDF Curves, Pre-Development Drainage Area Plan and SWM Calculations

Appendix F: Control Flow Roof Drain Information

Appendix G: CDS Unit Information

Appendix H: Drawings

## **LIST OF PLANS**

General Plan of Services (121060-GP)

Grading and Erosion & Sediment Control Plan (121060-GR)

Stormwater Management Plan (120169-SWM)

Plan & Profile Montreal Road Sanitary Sewer (121060-PP)

Sanitary Drainage Area Plan (120169-SAN)

Pump Station Wet Well details (120169-PS)

## 1.0 INTRODUCTION

The new residential development is being proposed by Landric Homes and Novatech has been retained to complete the site servicing and stormwater management design for this project.

This report addresses the approach to site servicing and stormwater management and is being submitted in support of a zoning by-law amendment and site plan control application.

### 1.1 Site Description and Location

The subject site is approximately 0.8 hectares in size and currently occupied by two single family homes (1765 Montreal Road and 9 Beckenham Lane). The subject site is located immediately west of the Montfort Renaissance facility. The site is bordered by Montreal Road to the south, Beckenham Lane to the west and Cedar Road to the north. The description of the subject site is designated as Lots 24 and 25, Registered Plan 462, City of Ottawa.

**Figure 1 – Aerial Plan** provides an aerial view of the site.

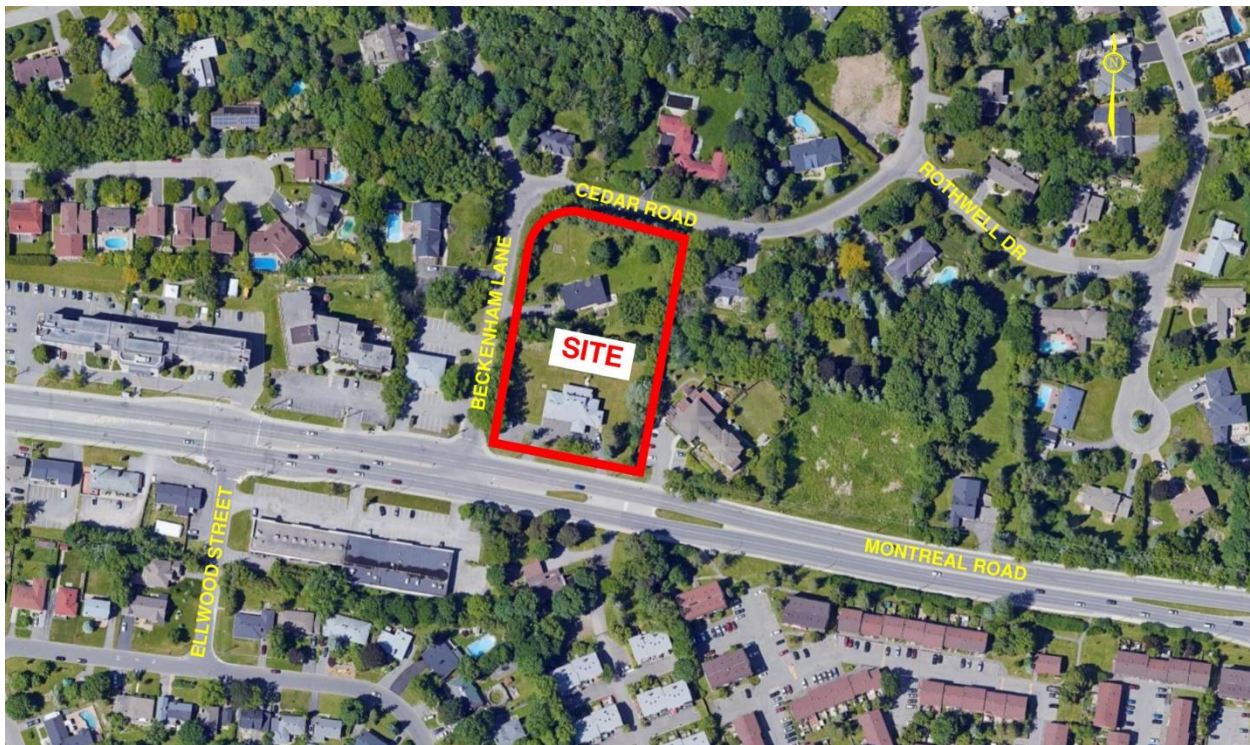

### 1.2 Pre-Consultation Information

A pre-consultation meeting was held with the City of Ottawa on July 26, 2021, at which time the client was advised of the general submission requirements.

The subject site is located within the jurisdiction of the Rideau Valley Conservation Authority (RVCA). Based on preliminary feedback from the RVCA, the proposed development will require an 'Enhanced' Level of Protection (i.e. 80% TSS removal) for storm sewer connection to the Montreal Road. Storm sewer connection to the Cedar Road ditch will not require water quality control. Refer to **Appendix A** for correspondence from the RVCA and City of Ottawa related to the proposed development.

### 1.3 Proposed Development

The proposed development will consist of a new 9-storey highrise building and two 3-storey townhouse blocks replacing the two existing single-family homes. The development will include a surface parking lot and an underground parking garage. The site will be accessed via two driveways, one to Montreal Road and one to Beckenham Lane. Refer to architectural Site Plan accompanying the site plan application for details.

### 1.4 Reference Material

The following reports and studies were reviewed as part of the design process:

<sup>1</sup> The Geotechnical Investigation report (Report No.: PG5736-1), prepared by Paterson Group Inc. dated April 23, 2021.

## 2.0 SITE SERVICING

The objective of the site servicing design is to provide proper sewage outlets, a suitable domestic water supply and to ensure that appropriate fire protection is provided for the proposed development. The servicing criteria, the expected sewage flows, and the water demands are to conform to the City of Ottawa municipal design guidelines for sewer and water distribution systems. Refer to the subsequent sections of the report for further details.

The City of Ottawa Servicing Study Guidelines for Development Applications requires that a Development Servicing Study Checklist be included to confirm that each applicable item is deemed complete and ready for review by City of Ottawa Infrastructure Approvals. A completed checklist is enclosed in **Appendix B** of the report.

### 2.1 Sanitary Sewage

There are no existing municipal sanitary sewers fronting the site. The existing residential properties on site are serviced by private septic systems.

The closest municipal sanitary sewer to the site is a 250mm diameter sewer in Montreal Road that is terminated approximately 30m west of the site. This sanitary sewer will have to be extended to the frontage of the property to service the proposed development. The 9-storey high-rise building will drain by gravity to the proposed sanitary sewer extension via the proposed 250mm diameter sanitary service. A private sanitary pump station will be required to service the proposed townhouses due to higher elevation of the sanitary sewer in Montreal Road.

The City of Ottawa design criteria were used to calculate the theoretical sanitary flows for the proposed development. The following design criteria were taken from Section 4 – 'Sanitary Sewer Systems' and Appendix 4-A - 'Daily Sewage Flow for Various Types of Establishments' of the City of Ottawa Sewer Design Guidelines:

- Residential Units (1-Bedroom): 1.4 persons per unit
- Residential Units (2-Bedroom): 2.1 persons per unit
- Townhouse Units: 2.7 persons per unit
- Average Daily Residential Sewage Flow: 280 L/person/day
- Residential Peaking Factor calculated by the Harmon Equation
- Infiltration Allowance: 0.33 L/s/ha

The peak sanitary flows from the proposed development, including infiltration, are summarized in **Table 2.1**. The detailed sanitary flow calculations and sanitary sewer design sheet are provided in **Appendix D**.

**Table 2.1: Peak Sanitary Flows**

9-Storey Highrise Building	3-Storey Townhouses	Total Peak Sanitary Flow
2.87 L/s	0.41 L/s	3.28 L/s

The proposed 250mm dia. sanitary gravity sewer at a minimum slope of 0.5% has a full flow conveyance capacity of 43.9 L/s and will have enough capacity to convey the theoretical sanitary flows for the proposed addition. Furthermore, the existing 250mm dia. municipal sanitary sewer is also at a steeper slope of 1.13% with a full flow conveyance capacity of approximately 65.9 L/s and the system should have sufficient capacity to convey the sanitary flows from the site.

### 2.1.1 Sanitary Pump Station

Sanitary sewage from the townhouses will need to be pumped due to the higher elevation of the receiving sewer on Montreal Road. Sewage from the townhouses will drain to a 1800mm wet well located near the entrance. The wet well will contain duplex 3HP grinder pumps, level controls, check valves and isolation valves for each pump. Pumps will discharge to a 50mm forcemain which will discharge to the sanitary manhole approximately 10m north of Montreal Road. A control panel will be located at the wet well, which will contain pump controls and a general alarm light in the event of any pump failures. A “stand-by” pump and an emergency power supply will also be provided.

## 2.2 Water

The proposed development will be serviced by connecting to the existing 200mm dia. municipal watermain in Beckenham Lane and to the existing 300mm diameter watermain in Montreal Road. Two 150mm diameter water services connected to the 200mm watermain in Beckenham Lane will be provided, one for the 9-storey condominium building and one for the two townhouse blocks. An additional 150mm water service connected to the 300mm watermain in Montreal Road is being proposed to provide redundancy for the 9-store high rise building as per the City of Ottawa standards.

The water services have been sized to provide the required domestic water demand and fire flow. Shut-off valves will be provided on the proposed water services at the property line in accordance with the City of Ottawa standards.

## 2.2.1 Domestic Water Demands and Watermain Analysis

The City of Ottawa design criteria were used to calculate the theoretical water demands for the proposed development. The following design criteria were taken from Section 4 – ‘Water Distribution Systems’ of the Ottawa Design Guidelines – Water Distribution:

- Residential Units (1 Bedroom Units): 1.4 persons per unit
- Residential Units (2 Bedroom Units): 2.1 persons per unit
- Townhouse Units: 2.7 persons per unit
- Average Daily Residential Water Demand: 350 L/person/day
- Maximum Day Demand Peaking Factor = 2.5 x Avg. Day Demand
- Peak Hour Demand Peaking Factor = 2.2 x Max. Day Demand

The domestic water demands for the proposed development are summarized in **Table 2.2**. The detailed water demand calculations are provided in **Appendix D**.

**Table 2.2: Domestic Water Demands**

Building	Average Day Demand	Maximum Day Demand	Peak Hour Demand
9-Storey Highrise Building	1.03 L/s	2.58 L/s	5.68 L/s
3-Storey Townhouses	0.13 L/s	0.33 L/s	0.74 L/s

The following design criteria were taken from Section 4.2.2 – ‘Watermain Pressure and Demand Objectives’ of the City of Ottawa Design Guidelines for Water Distribution:

- Maximum system pressure is not to exceed 552 kPa (80 psi)
- Minimum system pressures are to be >276 kPa (40 psi) under Peak Hour demands
- Minimum system pressures are to be >140 kPa (20 psi) under Max Day + Fire Flow demands

Preliminary domestic water demands, and fire flow requirements were provided to the City of Ottawa. These values were used to generate the municipal watermain network boundary conditions at the service connection points. **Table 2.3** summarizes the watermain boundary conditions provided by the City and the results of the hydraulic analysis.

**Table 2.2: Watermain Analysis – 9-Store Building**

Municipal Watermain Boundary Condition	Boundary Condition	Water Demand (L/s)	Min/Max Operating Pressure (psi)	Design Pressure (psi)*
Minimum HGL (Peak Hour Demand)	142.6 m	5.68	40 psi (min.)	52.8
Maximum HGL (Avg Day Demand)	143.0 m	1.03	80 psi (max.)	53.3
Max Day + Fire Flow HGL	105 m	67 + 2.58	20 psi (min.)	48.5

\* Based on an average ground elevation of 105.5m. Design pressure = (HGL – watermain elevation) x 1.42197 PSI/m



**Table 4: Watermain Analysis – Townhouses**

Municipal Watermain Boundary Condition	Boundary Condition	Water Demand (L/s)	Min/Max Operating Pressure (psi)	Design Pressure (psi)*
Minimum HGL (Peak Hour Demand)	142.6 m	1.4	40 psi (min.)	58.2
Maximum HGL (Avg Day Demand)	143.0 m	0.13	80 psi (max.)	58.7
Max Day + Fire Flow HGL	105 m	217 + 0.33	20 psi (min.)	21.8

\* Based on an average ground elevation of 101.7m. Design pressure = (HGL – watermain elevation) x 1.42197 PSI/m

As indicated above, the existing municipal watermain should provide adequate system pressures to the proposed development. It is anticipated that a booster pump will be required to increase pressure to the upper floors of the 9-Storey building.

### 2.2.2 Water Supply for Fire-Fighting

The proposed 9-storey building will be fully sprinklered and supplied with a fire department siamese connection. The proposed townhouses will not be sprinklered.

Fire Underwriters Survey (FUS) was used to estimate fire flow requirements for the proposed buildings. The fire flow calculations are based on the building information provided by the architect. As per the boundary conditions provided by the City, there is no sufficient fire water supply (233 L/s) for the north-east townhouse. Therefore, a 2-hour fire will be provided separating the north-east townhouse into two smaller fire areas reducing the fire flow to < 13,000 L/min. Refer to **Appendix D** for a copy of the FUS fire flow calculations and correspondence from the architect.

**Table 2.4** summarizes the fire flow requirements for the proposed buildings.

**Table 2.4: Fire Flow Requirements for the Proposed Development**

Type of Use	Fire Flow Demand
9-Storey Highrise Building	4,000 L/min (67 L/s)
3-Storey Townhouse (North-East)	9,000 L/min (150 L/s)
3-Storey Townhouse (North-West)	13,000 L/min (217 L/s)

There is an existing fire hydrant in Beckenham Lane that will provide fire protection to the 9-storey building. The hydrant is located within 45m of the fire department siamese connection located near the main entrance of the building. The existing hydrant is Class AA blue bonnet hydrant. Based on Table 1 Maximum flow to be considered from a given hydrant in Appendix I of Technical Bulletin ISTB-2018-02, the hydrant should provide 5,700 L/min exceeding the 4,000 L/min fire flow requirement for the 9-storey building.

A multi-hydrant approach to fire-fighting is anticipated to be required for the proposed townhouses. There are 3 Class AA, blue bonnet municipal hydrants within 150m of the townhouses (one municipal hydrant is in Beckenham Lane, one at the intersection of

Beckenham Lane and Cedar Road and one in Cedar Road east from the site). The hydrant in Beckenham Lane is located within 75m from the north-west townhouse and within 150m from the north-east townhouse. The hydrant at the intersection of Beckenham Lane and Cedar Road is located within 75m from both townhouses. The hydrant in Cedar Road is located within 75m from the north-east townhouse and within 150m from the north-west townhouse. Based on Table 1 Maximum flow to be considered from a given hydrant in Appendix I of Technical Bulletin ISTB-2018-02, the combined flows from the three hydrants are summarized below in **Table 2.5**.

**Table 2.5: Combined Hydrant Flow Summary**

Proposed Development	Fire Flow Demand	Fire Hydrants within 75m (~ 5,700 L/min each)	Fire Hydrants within 150m (~ 3,780 L/min each)	Combined Available Fire Flow
Townhouse (North-East)	9,000 L/min (150 L/s)	2	1	15,180 (253 L/s)
Townhouse (North-West)	13,000 L/min (217 L/s)	2	1	15,180 (253 L/s)

The combined maximum flow from these hydrants will exceed the Fire Flow requirement of the proposed townhouses.

The existing municipal watermain network should therefore have adequate fire water supply for the proposed development.

### 2.3 Storm Drainage and Stormwater Management

Due to grading constraints, storm drainage from the site will be directed in two directions. The storm drainage from the 9-storey building portion of the site will outlet to the existing 300mm dia. storm sewer in Montreal Road. The storm drainage from the townhouses portion of the site will outlet to the Cedar Road roadside ditch.

#### 2.3.1 Stormwater Management Criteria and Objectives

The stormwater management criteria and objectives for the site are as follows:

- Provide best measures to control the post-development flows from the site to a target 5-year release rate specified by the City of Ottawa. Control post-development flows from the site being developed up to and including the 100-year design event.
- Maximize the use of storage on the on the building roofs and within an internal SWM storage tank to provided quantity control for the proposed development.
- Provide stormwater quality control as per RVCA requirements.
- Provide guidelines to ensure that site preparation and construction is in accordance with the current Best Management Practices for Erosion and Sediment Control.

#### 2.3.2 Pre-Development Conditions and Allowable Release Rate

The entire site is approximately 0.8 ha in size and is comprised of two existing residential dwellings. The existing properties primarily sheet drain uncontrolled to the Cedar Road roadside

ditch (identified as area EX-1 on the Pre-development Drainage Area Plan in **Appendix E**). The front portion the existing property facing Montreal Road sheet drain uncontrolled to the existing catchbasins in Montreal Road (identified as EX-2). There is currently no stormwater quantity or quality control measures on-site.

The pre-development flows from the 0.634 ha portion of the site draining towards Cedar Road ditch were calculated using the Rational Method to be 57.2 L/s during the 1:5-year design event and 113.6 L/s during the 1:100-year design event. The pre-development flows from the 0.165 ha portion of the site draining towards Montreal Road catchbasins were calculated using the Rational Method to be 26.5 L/s during the 1:5-year design event and 51.5 L/s during the 1:100-year design event. Refer to **Appendix E** for detailed calculations.

As specified by the City of Ottawa, the allowable release rate from the site was calculated using the Rational Method, to be approximately 115.7 L/s, based on a 10-min rainfall intensity, using a 5-year return period (City of Ottawa IDF Curves) and a runoff coefficient of 0.50.

$$\begin{aligned}
 T_c &= 10 \text{ min} & C &= 0.50 \\
 I_{5\text{yr}} &= 104.2 \text{ mm/hr} & A &= 0.799 \text{ ha} \\
 \\ 
 A_{\text{allow}} &= 2.78 \text{ CIA} \\
 &= 2.78 \times 0.50 \times 104.2 \times 0.799 \\
 &= 115.7 \text{ L/s}
 \end{aligned}$$

### 2.3.3 Post-Development Conditions

In post-development conditions, the storm drainage from the 9-storey building portion of the site will outlet to the existing 300mm dia. storm sewer in Montreal Road. The storm drainage from the townhouses portion of the site will outlet to the Cedar Road ditch. The proposed building roofs will be equipped with flow-control roof drains. An internal stormwater management tank will be provided to control post-development flows from the 9-storey building rooftop terraces and the proposed surface parking lot.

#### 2.3.3.1 Area A-1: Uncontrolled Direct Runoff to Montreal Road

The uncontrolled post-development flow from this sub-catchment area was calculated using the Rational Method to be approximately 8.7 L/s during the 5-year design event and 17.0 L/s during the 100-year design event. Refer to **Appendix E** for detailed calculations.

#### 2.3.3.2 Area A-2: Uncontrolled Direct Runoff to Cedar Road

The uncontrolled post-development flow from this sub-catchment area was calculated using the Rational Method to be approximately 4.3 L/s during the 5-year design event and 9.3 L/s during the 100-year design event. Refer to **Appendix E** for detailed calculations.

#### 2.3.3.3 Area A-3: Controlled Flow – Townhouse Roof (North-West)

The post-development flow from this sub-catchment area will be attenuated by ten (6) individual Watts adjustable 'Accutrol' control flow roof drains (model number RD-100-A-ADJ) prior to being directed to the proposed storm service, by-passing the internal SWM storage tank.

**Table 2.6** summarizes the post-development design flows from this sub-catchment area as well as the type of roof drains, the maximum anticipated ponding depths, storage volumes required, and storage volumes provided for both the 5-year and the 100-year design events.

**Table 2.6: Design Flow and Roof Drain Table**

Roof Drain ID & Drainage Area (ha)	Number of Roof Drains	Watts Roof Drain Model ID (Weir Opening)	Controlled Flow per Drain (L/s)		Approximate Ponding Depth Above Drains (m)		Storage Volume Required (m <sup>3</sup> )		Max. Storage Available (m <sup>3</sup> )
			5-Yr	100-Yr	5-Yr	100-Yr	5-Yr	100-Yr	
RD-1 (0.007 ha)	1	RD-100-A-ADJ (Closed)	0.32	0.32	0.11	0.14	1.2	2.9	3.2
RD-2 (0.007 ha)	1	RD-100-A-ADJ (Closed)	0.32	0.32	0.11	0.14	1.2	2.9	3.2
RD-3 (0.007 ha)	1	RD-100-A-ADJ (Closed)	0.32	0.32	0.11	0.14	1.2	2.9	3.2
RD-3 (0.007 ha)	1	RD-100-A-ADJ (Closed)	0.32	0.32	0.11	0.14	1.2	2.9	3.2
RD-5 (0.007 ha)	1	RD-100-A-ADJ (Closed)	0.32	0.32	0.11	0.14	1.2	2.9	3.2
RD-6 (0.007 ha)	1	RD-100-A-ADJ (Closed)	0.32	0.32	0.11	0.14	1.2	2.9	3.2
<b>Total Roof (0.043 ha)</b>	<b>6</b>	<b>-</b>	<b>1.9</b>	<b>1.9</b>	<b>-</b>	<b>-</b>	<b>7.2</b>	<b>17.2</b>	<b>18.9</b>

Refer to **Appendix E** for detailed SWM calculations and to **Appendix F** for roof drain information. As indicated in the table above, the townhouse roof will provide sufficient storage for both the 5-year and 100-year design events.

#### 2.3.3.4 Area A-4: Controlled Flow – Townhouse Roof (North-East)

The post-development flow from this sub-catchment area will be attenuated by ten (6) individual Watts adjustable ‘Accutrol’ control flow roof drains (model number RD-100-A-ADJ) prior to being directed to the proposed storm service, by-passing the internal SWM storage tank.

**Table 2.7** summarizes the post-development design flows from this sub-catchment area as well as the type of roof drains, the maximum anticipated ponding depths, storage volumes required, and storage volumes provided for both the 5-year and the 100-year design events.

**Table 2.7: Design Flow and Roof Drain Table**

Roof Drain ID & Drainage Area (ha)	Number of Roof Drains	Watts Roof Drain Model ID (Weir Opening)	Controlled Flow per Drain (L/s)		Approximate Ponding Depth Above Drains (m)		Storage Volume Required (m <sup>3</sup> )		Max. Storage Available (m <sup>3</sup> )
			5-Yr	100-Yr	5-Yr	100-Yr	5-Yr	100-Yr	
RD-1 (0.007 ha)	1	RD-100-A-ADJ (Closed)	0.32	0.32	0.11	0.14	1.2	2.9	3.2
RD-2 (0.007 ha)	1	RD-100-A-ADJ (Closed)	0.32	0.32	0.11	0.14	1.2	2.9	3.2

RD-3 (0.007 ha)	1	RD-100-A-ADJ (Closed)	0.32	0.32	0.11	0.14	1.2	2.9	3.2
RD-3 (0.007 ha)	1	RD-100-A-ADJ (Closed)	0.32	0.32	0.11	0.14	1.2	2.9	3.2
RD-5 (0.007 ha)	1	RD-100-A-ADJ (Closed)	0.32	0.32	0.11	0.14	1.2	2.9	3.2
RD-6 (0.007 ha)	1	RD-100-A-ADJ (Closed)	0.32	0.32	0.11	0.14	1.2	2.9	3.2
<b>Total Roof (0.043 ha)</b>	<b>6</b>	<b>-</b>	<b>1.9</b>	<b>1.9</b>	<b>-</b>	<b>-</b>	<b>7.2</b>	<b>17.2</b>	<b>18.9</b>

Refer to **Appendix E** for detailed SWM calculations and to **Appendix F** for roof drain information. As indicated in the table above, the townhouse roof will provide sufficient storage for both the 5-year and 100-year design events.

### 2.3.3.5 Area A-5: Controlled Flow – 9-Storey Building Roof

The post-development flow from this sub-catchment area will be attenuated by ten (10) individual Watts adjustable ‘Accutrol’ control flow roof drains (model number RD-100-A-ADJ) prior to being directed to the proposed storm service, by-passing the internal SWM storage tank.

**Table 2.8** summarizes the post-development design flows from this sub-catchment area as well as the type of roof drains, the maximum anticipated ponding depths, storage volumes required, and storage volumes provided for both the 5-year and the 100-year design events.

**Table 2.8: Design Flow and Roof Drain Table**

Roof Drain ID & Drainage Area (ha)	Number of Roof Drains	Watts Roof Drain Model ID (Weir Opening)	Controlled Flow per Drain (L/s)		Approximate Ponding Depth Above Drains (m)		Storage Volume Required (m <sup>3</sup> )		Max. Storage Available (m <sup>3</sup> )
			5-Yr	100-Yr	5-Yr	100-Yr	5-Yr	100-Yr	
RD-13 (0.010 ha)	1	RD-100-A-ADJ (Closed)	0.32	0.32	0.11	0.14	1.9	4.5	5.1
RD-14 (0.010 ha)	1	RD-100-A-ADJ (1/4 Exposed)	0.79	0.87	0.10	0.13	1.2	3.0	4.0
RD-15 (0.008 ha)	1	RD-100-A-ADJ (Closed)	0.32	0.32	0.11	0.14	1.4	3.3	4.0
RD-16 (0.010 ha)	1	RD-100-A-ADJ (Closed)	0.32	0.32	0.11	0.14	1.9	4.5	5.1
RD-17 (0.010 ha)	1	RD-100-A-ADJ (Closed)	0.32	0.32	0.11	0.14	1.9	4.5	5.1
RD-18 (0.013 ha)	1	RD-100-A-ADJ (1/4 Exposed)	0.79	0.87	0.10	0.13	1.8	4.4	6.7
RD-19 (0.012 ha)	1	RD-100-A-ADJ (1/4 Exposed)	0.75	0.87	0.09	0.13	1.6	4.0	6.4
RD-20 (0.015 ha)	1	RD-100-A-ADJ (1/4 Exposed)	0.79	0.87	0.10	0.13	2.2	5.4	7.5

RD-21 (0.014 ha)	1	RD-100-A-ADJ (1/4 Exposed)	0.79	0.91	0.10	0.14	2.0	4.8	6.0
RD-22 (0.014 ha)	1	RD-100-A-ADJ (1/4 Exposed)	0.79	0.87	0.10	0.13	2.0	4.9	6.8
<b>Total Roof (0.117 ha)</b>	<b>10</b>	<b>-</b>	<b>6.0</b>	<b>6.5</b>	<b>-</b>	<b>-</b>	<b>17.9</b>	<b>43.4</b>	<b>56.7</b>

Refer to **Appendix E** for detailed SWM calculations and to **Appendix F** for roof drain information. As indicated in the table above, the building roof will provide sufficient storage for both the 5-year and 100-year design events.

### 2.3.3.6 Area A-6: Uncontrolled Flow to Cedar Road

The uncontrolled post-development flow from this sub-catchment area was calculated using the Rational Method to be approximately 31.5 L/s during the 5-year design event and 61.1 L/s during the 100-year design event. Refer to **Appendix E** for detailed calculations.

### 2.3.3.7 Area A-7: Controlled Flow from Internal SWM Tank

Stormwater runoff from this sub-catchment area will be captured by the proposed deck drains and uncontrolled building roof drains prior to being directed to an internal stormwater storage tank. Stormwater collected within the storage tank will be pumped up to the proposed storm service and released into the building service which in turn outlets to the municipal sewer in Montreal Road. A pump (designed by the mechanical consultant) is required to control flow from the tank to a maximum rate of 15.1 L/s (240 USGPM), which corresponds to the available flow allocated for this catchment area. A “stand-by” pump will be provided for emergency and/or maintenance purposes. An emergency back-up power supply will also be provided. The storm service will be equipped with a backflow prevention device to protect the building from any potential sewer back-ups.

**Table 2.9** summarizes the post-development stormwater design flows and storage volumes for both the 5-year and 100-year design events.

**Table 2.9: Internal Stormwater Storage Tank and Pumped Flow**

Design Event	Post-Development Conditions		
	Pumped Design Flow (L/s)	Volume Required (m <sup>3</sup> )	Volume Provided (m <sup>3</sup> )
1:2 Year	15.1 L/s	21.4 m <sup>3</sup>	> 116.4 m <sup>3</sup>
1:5 Year	15.1 L/s	34.9 m <sup>3</sup>	
1:100 Year	15.1 L/s	90.4 m <sup>3</sup>	
1:100 Year + 20% IDF increase	15.1 L/s	116.4 m <sup>3</sup>	

As indicated in the table above, the internal stormwater storage tank will provide adequate storage for both the 5-year and 100-year design events, including an increased volume due to a 20% increase in rainfall intensity. Refer to **Appendix E** for detailed calculations.

### 2.3.4 Stormwater Flow Summary

**Table 3.0** provides a summary of the total post-development flows from the site and compares them to the uncontrolled pre-development flows and target release rate specified by the City.

**Table 3.0: Stormwater Flow Comparison Table**

Design Event	Pre-Development Conditions	Post-Development Conditions							
	Uncontrolled Flow (L/s)	A-1 Flow (L/s)	A-2 Flow (L/s)	A-3 Flow (L/s)	A-4 Flow (L/s)	A-5 Flow (L/s)	A-6 Flow (L/s)	A-7 Flow (L/s)	Total Flow (L/s)
5-Yr	83.6	8.7	4.3	1.9	1.9	6.0	31.5	15.1	69.5
100-Yr	167.8	17.0	9.3	1.9	1.9	6.5	61.1	15.1	112.9

The total post-development flow from the site will be released from the proposed development at a combined maximum rate of 112.9 L/s during the 1:100 year design event and 69.5 L/s during the 1:5 year design event; both of which are less than the allowable flow for the site of 115.7 L/s. As indicated in the table above, the total post-development flows from the site represent a significant reduction in flows when compared to pre-development conditions.

## 2.4 Stormwater Quality Control

The subject site is located within the jurisdiction of the Rideau Valley Conservation Authority (RVCA) and is in the Rideau River tributary area. An 'Enhanced' Level of Protection, equivalent to a long-term average removal of 80% of total suspended solids (TSS), with at least 90% of the total rainfall being captured and treated, is required for the storm outlet to Montreal Road storm sewer. The storm outlet to the Cedar Road ditch does not require water quality control.

In order to achieve this level of quality control protection, a new oil-grit separator unit (CDS Model PMSU 20\_15\_4m) will be installed on the proposed 250mm diameter storm sewer outlet pipe from the site. Stormwater runoff from the 0.399 ha tributary area will be directed through the proposed treatment unit. The contributing area includes the proposed surface parking lot and the 9-storey building roof.

As stated above, the proposed oil-grit separator has been sized to provide an Enhanced Level of water quality treatment prior to discharging the stormwater towards the municipal storm sewer in Montreal Road. Echelon Environmental and Contech Engineering Solutions Inc. have modeled the tributary area to provide a CDS unit capable of meeting the TSS removal requirements. The model parameters for the TSS removal were based on historical rainfall data for Ottawa. It was determined that a CDS Model PMSU 2015\_4 will exceed the target removal rate, providing a net annual 84.5% TSS removal. The CDS unit has a sediment storage capacity of 838 L; an oil storage capacity of 232 L and will treat a net annual volume of approximately 98.6% for the tributary area.

## Maintenance and Monitoring of Storm Sewer and SWM Systems

It is recommended that the client implements a maintenance and monitoring program for both the on-site storm sewer and the stormwater management systems: The storm drainage system should be inspected routinely, and the oil-grit separator should be inspected at regular intervals and maintained when necessary to ensure optimum performance. Refer to **Appendix G** for the CDS unit operation, design and maintenance summary parameters as well as the annual TSS removal efficiency data.

### **3.0 SITE GRADING**

The intent of the grading design was to propose the building finished floor elevations to best tie into the elevations along the existing adjacent roadways and surrounding property lines, and to provide mayor overland flow route towards Montreal Road and Backhenhem Lane right-of ways. The proposed grading design provides positive drainage away from the buildings and towards the on-site stormwater drainage structures. Due to substantial grade difference between front and back of the property, a large retaining wall is required between the 9-store building and the 3-store townhouses. A retaining wall is also required along the east property line.

#### **3.1 Emergency Overland Flow Route**

In the case of a major rainfall event exceeding the design storms provided for, the stormwater located within the subject site will overflow towards the Montreal Road and Backhenhem Lane. The floor elevation of the proposed buildings will be a minimum of 0.30m above the major system overflow points. No surface ponding will be able to reach the building envelope or any of the proposed building openings. The emergency overland flow route is shown on the enclosed Grading and Erosion & Sediment Control Plan.

### **4.0 GEOTECHNICAL INVESTIGATIONS**

A Geotechnical Investigation report has been prepared by Paterson Group for the proposed project. Refer to the Geotechnical Report<sup>1</sup> for subsurface conditions, construction recommendations and geotechnical inspection requirements.

### **5.0 EROSION AND SEDIMENT CONTROL**

To mitigate erosion and to prevent sediment from entering the storm sewer system, temporary erosion and sediment control measures will be implemented on-site during construction in accordance with the Best Management Practices for Erosion and Sediment Control. This includes the following temporary measures:

- Filter bags will be placed under the grates of nearby catchbasins, manholes and will remain in place until vegetation has been established and construction is completed.
- Silt fencing will be placed per OPSS 577 and OPSD 219.110 along the surrounding construction limits.
- A mud mat will be installed at the construction entrance for the site.
- Street sweeping and cleaning will be performed, as required, to suppress dust and to provide safe and clean roadways adjacent to the construction site.
- On-site dewatering is to be directed to a sediment trap and/or gravel splash pad and discharged safely to an approved outlet as directed by the engineer.



The temporary erosion and sediment control measures will be implemented prior to construction and will remain in place during all phases of construction. Regular inspection and maintenance of the erosion control measures will be undertaken.

## **6.0 CONCLUSION**

This report has been prepared in support of a zoning by-law amendment and site plan control application for the proposed residential development located at 1765 Montreal Road in the City of Ottawa. The conclusions are as follows:

### Watermain

- The proposed 150m diameter watermains can adequately service the proposed development.
- There are adequate flows and pressure in the municipal watermain system to meet the required domestic water demand for the development.
- The existing municipal fire hydrants can provide adequate fire water supply for the development.

### Sanitary Servicing

- The existing 250mm diameter sanitary sewer in Montreal Road will be extended to service the proposed development
- A sanitary pump station will be provided to pump sewage from the proposed townhouses to the Montreal Road sewer.
- Sanitary sewage from the 9-storey building will outlet by gravity to the Montreal Road sewer.
- There is adequate capacity within the proposed and existing sanitary infrastructure to service the proposed development.

### Stormwater Management

- The total post-development flow from the site will be released from the development at a combined maximum rate of 112.9 L/s during the 1:100 year design event and 69.5 L/s during the 1:5 year design event; both of which are less than the allowable flow from the site of 115.7 L/s.
- On-site stormwater quality treatment for storm drainage outletting to the Montreal Road storm sewer will be provided by the installation of an oil-grit separator. The OGS unit will provide 'Enhanced' Level of Protection as per the RVCA requirements.
- Temporary erosion and sediment control measures will be provided during construction.

It is recommended that the proposed site servicing and stormwater management design be approved for implementation.

**NOVATECH**

Prepared by:



Miroslav Savic, P. Eng  
Senior Project Manager

Reviewed by:

A handwritten signature in black ink, appearing to read "Lee Sheets".

Lee Sheets, C.E.T.  
Director

**APPENDIX A**  
**Correspondence**

**Site Plan Pre- Application Consultation Notes**

**Date:** Monday, July 26, 2021

**Site Location:** 176 Montreal Road

**Type of Development:**  Residential ( townhomes,  stacked,  singles,  apartments),  Office Space,  Commercial,  Retail,  Institutional,  Industrial, Other: N/A

**Infrastructure**

**Water**

Existing public services:

- Montreal – 305mm DI
- Beckham – 203mm DI
- Cedar – 203mm DI



Watermain Frontage Fees to be paid (\$190.00 per metre) Cedar Road and Beckham Lane  **Yes**  **No**

**Boundary conditions:**

Civil consultant must request boundary conditions from the City’s assigned Project Manager prior to first submission.

- Water boundary condition requests must include the location of the service(s) and the expected loads required by the proposed developments. Please provide all the following information:
  - Location of service(s)
  - Type of development and the amount of fire flow required (as per FUS, 1999)
  - Average daily demand: \_\_\_ L/s
  - Maximum daily demand: \_\_\_ L/s
  - Maximum hourly daily demand: \_\_\_ L/s
- Fire protection (Fire demand, Hydrant Locations)
- Please submit sanitary demands with the water boundary conditions to identify any capacity constraints at the local pumping station

**General comments**

- Service areas with a basic demand greater than 50 m<sup>3</sup>/day shall be connected with a minimum of two water services, separated by an isolation valve, to avoid creation of vulnerable service area.
- A District Metering Area Chamber (DMA) is required for services 150mm or greater in diameter.

- The existing water services must be blanked at the main.

### Sanitary Sewer

Existing public services:

- Montreal Rd – 200mm Conc.

Private servicing:

- A private sanitary sewer runs through 1777, 1795 Montreal, 41 Cedar onto Rothwell Dr. The applicant may considered discussing with the neighbouring property to extended the private sewer.



### General comments

- The existing sanitary sewer must be extended to the frontage of the property.
- It is anticipated that the proposed high-rise will drain by gravity to the sanitary sewer.
- The proposed townhomes may be pumped. A back-up pump and generator will be requested. All servicing portions within the ROW must drain by gravity. Private force mains within the ROW are strongly discouraged.
- A Transfer of Review ECA will be required for the proposed sanitary sewer extension and private sanitary sewer under Section 53 of OWRA.
- For concrete sewer pipe, maintenance holes shall be installed when the service is greater than 50% of the diameter of the mainline concrete pipe.

### Storm Sewer

Existing public services:

- Montreal Rd – 300mm Conc, 300mm PVC



### General comments

- Ensure that the proposed drive ramp entrance to the underground parking garage is protected from the major overland flow route.
  - A minimum freeboard elevation of 350mm from highpoint of the ramp to the street spill elevation.
  - A minimum freeboard elevation of 300mm from the invert of the ramp drain to the 100 year HGL of the storm sewer.
  - In general conformity of City of Ottawa Standard S17.

- In order to minimize number of storm sewer connections the foundation drain and the drive ramp drain may connect to site sewer under free-flow conditions. The system must be designed to ensure that drainage does not back-up into the building drain or drive ramp.

### **Stormwater Management**

---

Quality Control:

- Rideau Valley Conservation Authority to confirm quality control requirements.

Quantity Control:

- Site is located within Cyrville Drain Subwatershed Study Area
- Time of concentration (Tc): Tc = pre-development; maximum Tc = 10 min
- Allowable run-off coefficient C = 0.5
- Allowable flowrate: Allowable flowrate: Control the 100-year storm events to the 2-year storm event.

### **Ministry of Environment, Conservation and Parks (MECEP)**

---

All development applications should be considered for an Environmental Compliance Approval, under MECP regulations.

- a. Consultants are required to determine if an approval for sewage works under Section 53 of OWRA is required. The City's opinion is that a direct submission ECA will be required.
- b. ECA applications are required to be submitted online through the MECP portal. A business account required to submit ECA application. For more information visit <https://www.ontario.ca/page/environmental-compliance-approval>

**NOTE: Site Plan Approval, or Draft Approval, is required before any Ministry of the Environment and Climate Change (MOECC) application is sent**

### **General Service Design Comments**

---

- Existing sewer or watermains that are not reused must be decommissioned as per City Standards. Please show all road cuts on the plans.
- The City of Ottawa Standard Detail Drawings should be referenced where possible for all work within the Public Right-of-Way.

### **Other**

---

Capital Works Projects within proximity to application?  Yes  No

### **References and Resources**

---

- As per section 53 of the Professional Engineers Act, O. Reg 941/40, R.S.O. 1990, all documents prepared by engineers must be signed and dated on the seal.
- All required plans & reports are to be provided in \*.pdf format (at application submission and for any, and all, re-submissions)
- Please find relevant City of Ottawa Links to Preparing Studies and Plans below:  
<https://ottawa.ca/en/city-hall/planning-and-development/information-developers/development-application-review-process/development-application-submission/guide-preparing-studies-and-plans#standards-policies-and-guidelines>
- To request City of Ottawa plan(s) or report information please contact the City of Ottawa Information Centre:  
[InformationCentre@ottawa.ca](mailto:InformationCentre@ottawa.ca)<mailto:InformationCentre@ottawa.ca>  
(613) 580-2424 ext. 44455
- geoOttawa  
<http://maps.ottawa.ca/geoOttawa/>

## PLANS & STUDIES LIST

For information on preparing required studies and plans refer to:

<http://ottawa.ca/en/development-application-review-process-0/guide-preparing-studies-and-plans>

S/A	Number of copies	ENGINEERING		S/A	Number of copies
S		1. Site Servicing Plan	2. Site Servicing Brief	S/Z	
S		3. Grade Control and Drainage Plan	4. Geotechnical Study	S/Z	
		5. Composite Utility Plan	6. Groundwater Impact Study		
		7. Servicing Options Report	8. Wellhead Protection Study		
		9. Community Transportation Study and/or Transportation Impact Study / Brief	10. Erosion and Sediment Control Plan / Brief	S	
S/Z		11. Storm water Management Brief	12. Hydro-geological and Terrain Analysis		
		13. Water main Analysis	14. Noise / Vibration Study	S	
		15. Roadway Modification Design Plan	16. Confederation Line Proximity Study		

S – Required for Site Plan Control

Z – Required for Zoning By-Law Amendment

*It is important to note that the need for additional studies and plans may result during application review. If following the submission of your application, it is determined that material that is not identified in this checklist is required to achieve complete application status, in accordance with the Planning Act and Official Plan requirements, City Planning will notify you of outstanding material required within the required 30 day period. Mandatory pre-application consultation will not shorten the City's standard processing timelines, or guarantee that an application will be approved. It is intended to help educate and inform the applicant about submission requirements as well as municipal processes, policies, and key issues in advance of submitting a formal development application. This list is valid for one year following the meeting date. If the application is not submitted within this timeframe the applicant must again pre-consult with the City.*

### Notes:

4. Geotechnical Study / Slope Stability Study – required as per Official Plan section 4.8.3. All site plan applications need to demonstrate the soils are suitable for development. A Slope Stability Study may be required with unique circumstances (Schedule K or topography may define slope stability concerns).

10. Erosion and Sediment Control Plan – required with all site plan applications as per Official Plan section 4.7.3.

11. Stormwater Management Report/Brief - required with all site plan applications as per Official Plan section 4.7.6.

## Miro Savic

---

**From:** Rasool, Rubina <Rubina.Rasool@ottawa.ca>  
**Sent:** Tuesday, October 12, 2021 9:33 AM  
**To:** Miro Savic  
**Cc:** Steve Matthews  
**Subject:** RE: PC2021-0233 Pre-application Consultation - 1765 Montreal Road

Miro,

This sewer can be controlled 100-year to the 5-year storm events.

### Rubina

---

#### Rubina Rasool, E.I.T.

Project Manager

Planning, Infrastructure and Economic Development Department - Services de la planification, de l'infrastructure et du développement économique

Development Review – East Branch

City of Ottawa | Ville d'Ottawa

110 Laurier Avenue West Ottawa, ON | 110, avenue Laurier Ouest. Ottawa (Ontario) K1P 1J1 [rubina.rasool@ottawa.ca](mailto:rubina.rasool@ottawa.ca)

---

**From:** Miro Savic <m.savic@novatech-eng.com>  
**Sent:** September 30, 2021 2:47 PM  
**To:** Rasool, Rubina <Rubina.Rasool@ottawa.ca>  
**Cc:** Steve Matthews <S.Matthews@novatech-eng.com>  
**Subject:** FW: PC2021-0233 Pre-application Consultation - 1765 Montreal Road

**CAUTION: This email originated from an External Sender. Please do not click links or open attachments unless you recognize the source.**

**ATTENTION : Ce courriel provient d'un expéditeur externe. Ne cliquez sur aucun lien et n'ouvrez pas de pièce jointe, excepté si vous connaissez l'expéditeur.**

I'd like to get some clarification on the allowable release rate for the 1765 Montreal Road project. Why we need to control the 100-year storm event to the 2-year storm event? Typically for site developments we would control the 100-year storm to the 5-year year storm unless connection is made to a combined sewer. On our recent project two lots down the road (1795 Montreal Road) we were required to control the 100 year storm to the 5-year storm.

### Stormwater Management

---

Quality Control:

- Rideau Valley Conservation Authority to confirm quality control requirements.

Quantity Control:

- Site is located within Cyrville Drain Subwatershed Study Area
- Time of concentration (Tc): Tc = pre-development; maximum Tc = 10 min
- Allowable run-off coefficient C = 0.5
- Allowable flowrate: Allowable flowrate: Control the 100-year storm events to the 2-year storm event.



Thank you,

**Miroslav Savic**, P.Eng., Senior Project Manager | Land Development Engineering

**NOVATECH** Engineers, Planners & Landscape Architects

240 Michael Cowpland Drive, Suite 200, Ottawa, ON, K2M 1P6 | Tel: 613.254.9643 x 265 | Fax: 613.254.5867

The information contained in this email message is confidential and is for exclusive use of the addressee.

---

**From:** Katsouleas, Jonathan <[jonathan.katsouleas@ottawa.ca](mailto:jonathan.katsouleas@ottawa.ca)>

**Sent:** Friday, July 30, 2021 3:51 PM

**To:** Matthew Firestone <[matthew.firestone@landrichomes.com](mailto:matthew.firestone@landrichomes.com)>; Murray Chown <[m.Chown@novatech-eng.com](mailto:m.Chown@novatech-eng.com)>; Ryan Poulton <[r.poulton@novatech-eng.com](mailto:r.poulton@novatech-eng.com)>

**Cc:** Boughton, Michael <[Michael.Boughton@ottawa.ca](mailto:Michael.Boughton@ottawa.ca)>; Richardson, Mark <[Mark.Richardson@ottawa.ca](mailto:Mark.Richardson@ottawa.ca)>; Wood, Mary Ellen <[MaryEllen.Wood@ottawa.ca](mailto:MaryEllen.Wood@ottawa.ca)>; Richardson, Mark <[Mark.Richardson@ottawa.ca](mailto:Mark.Richardson@ottawa.ca)>; Young, Mark <[Mark.Young@ottawa.ca](mailto:Mark.Young@ottawa.ca)>; Rasool, Rubina <[Rubina.Rasool@ottawa.ca](mailto:Rubina.Rasool@ottawa.ca)>

**Subject:** PC2021-0233 Pre-application Consultation - 1765 Montreal Road

Hello Murray, Ryan and Matthew,

Please refer to the attached documents regarding the Pre-Application Consultation Meeting held on July 14, 2021 for the property at 1765 Montreal Road for Site Plan Control and Zoning By-Law Amendment in order to allow the proposed development. I have also attached the required Plans & Study List for application submission and Design Brief Information form.

Please do not hesitate to contact me if you have any questions.

Regards,

Jonathan

JONATHAN KATSOULEAS

Urban Planning Co-op Student | *Urbanisme, Étudiant Coop*

Development Review | *Examen des projets d'aménagement*

Planning, Infrastructure and Economic Development | *Service de la planification, de l'infrastructure et du développement économique*

City of Ottawa | Ville d'Ottawa

110 Laurier Avenue West, Ottawa, ON | 110, avenue Laurier Ouest (Ontario) K1P 1J1

This e-mail originates from the City of Ottawa e-mail system. Any distribution, use or copying of this e-mail or the information it contains by other than the intended recipient(s) is unauthorized. Thank you.

Le présent courriel a été expédié par le système de courriels de la Ville d'Ottawa. Toute distribution, utilisation ou reproduction du courriel ou des renseignements qui s'y trouvent par une personne autre que son destinataire prévu est interdite. Je vous remercie de votre collaboration.

This e-mail originates from the City of Ottawa e-mail system. Any distribution, use or copying of this e-mail or the information it contains by other than the intended recipient(s) is unauthorized. Thank you.

## Miro Savic

---

**From:** Jamie Batchelor <jamie.batchelor@rvca.ca>  
**Sent:** Thursday, December 15, 2022 1:31 PM  
**To:** Miro Savic  
**Cc:** Larry Colbran  
**Subject:** RE: 1765 Montreal Road - RVCA Pre-Consultation

Thanks Miro,

This is helpful. Based on the distance to the downstream outlet, the RVCA would not require additional on-site water quality treatment for the drainage area outletting to the Cedar Road ditch.

Jamie Batchelor, MCIP, RPP  
Planner, ext. 1191  
[jamie.batchelor@rvca.ca](mailto:jamie.batchelor@rvca.ca)



3889 Rideau Valley Drive  
PO Box 599, Manotick ON K4M 1A5  
T 613-692-3571 | 1-800-267-3504 F 613-692-0831 | [www.rvca.ca](http://www.rvca.ca)

This message may contain information that is privileged or confidential and is intended to be for the use of the individual(s) or entity named. If you are not the intended recipient of this e-mail, any use, review, revision, retransmission, distribution, dissemination, copying, printing or taking of any action in reliance upon this e-mail, is strictly prohibited. If you have received this e-mail in error, please contact the sender and any copy of the e-mail and any printout thereof, immediately. Your cooperation is appreciated.

---

**From:** Miro Savic <m.savic@novatech-eng.com>  
**Sent:** Thursday, December 15, 2022 9:26 AM  
**To:** Jamie Batchelor <jamie.batchelor@rvca.ca>  
**Cc:** Larry Colbran <l.colbran@novatech-eng.com>  
**Subject:** RE: 1765 Montreal Road - RVCA Pre-Consultation

Hi Jamie,

According to the mapping on GeoOttawa the roadside ditch is tributary to Greens Creek. Refer to the attached sketch. The distance to the downstream outlet is about 3km from the site (more than 2km).

Regards,

**Miroslav Savic**, P.Eng., Senior Project Manager | Land Development Engineering

**NOVATECH** Engineers, Planners & Landscape Architects

240 Michael Cowpland Drive, Suite 200, Ottawa, ON, K2M 1P6 | Tel: 613.254.9643 x 265 | Fax: 613.254.5867

The information contained in this email message is confidential and is for exclusive use of the addressee.

---

**From:** Jamie Batchelor <[jamie.batchelor@rvca.ca](mailto:jamie.batchelor@rvca.ca)>  
**Sent:** Wednesday, December 14, 2022 4:36 PM

**To:** Miro Savic <[m.savic@novatech-eng.com](mailto:m.savic@novatech-eng.com)>  
**Cc:** Larry Colbran <[l.colbran@novatech-eng.com](mailto:l.colbran@novatech-eng.com)>  
**Subject:** RE: 1765 Montreal Road - RVCA Pre-Consultation

Hi Miro,

It is not clear to me based on the mapping I have available as to where the roadside ditch network ultimately drain to a downstream outlet. Would you be able to shed some light on this?

Jamie Batchelor, MCIP, RPP  
Planner, ext. 1191  
[Jamie.batchelor@rvca.ca](mailto:Jamie.batchelor@rvca.ca)



3889 Rideau Valley Drive  
PO Box 599, Manotick ON K4M 1A5  
T 613-692-3571 | 1-800-267-3504 F 613-692-0831 | [www.rvca.ca](http://www.rvca.ca)

This message may contain information that is privileged or confidential and is intended to be for the use of the individual(s) or entity named. If you are not the intended recipient of this e-mail, any use, review, revision, retransmission, distribution, dissemination, copying, printing or taking of any action in reliance upon this e-mail, is strictly prohibited. If you have received this e-mail in error, please contact the sender and any copy of the e-mail and any printout thereof, immediately. Your cooperation is appreciated.

---

**From:** Miro Savic <[m.savic@novatech-eng.com](mailto:m.savic@novatech-eng.com)>  
**Sent:** Tuesday, December 13, 2022 10:55 AM  
**To:** Jamie Batchelor <[jamie.batchelor@rvca.ca](mailto:jamie.batchelor@rvca.ca)>  
**Cc:** Larry Colbran <[l.colbran@novatech-eng.com](mailto:l.colbran@novatech-eng.com)>  
**Subject:** RE: 1765 Montreal Road - RVCA Pre-Consultation

Hello Jamie,

Thank you for quick response.

Can you please confirm whether the storm water quality control is required for outlet to the Cedar Road ditch as well. The area draining to the ditch consist of 14 parking spaces, driveways, townhouse roofs, and landscaped areas. See sketch below. Sorry I wasn't clear in my original email.

Please do not hesitate to call should you have any questions or require additional information.

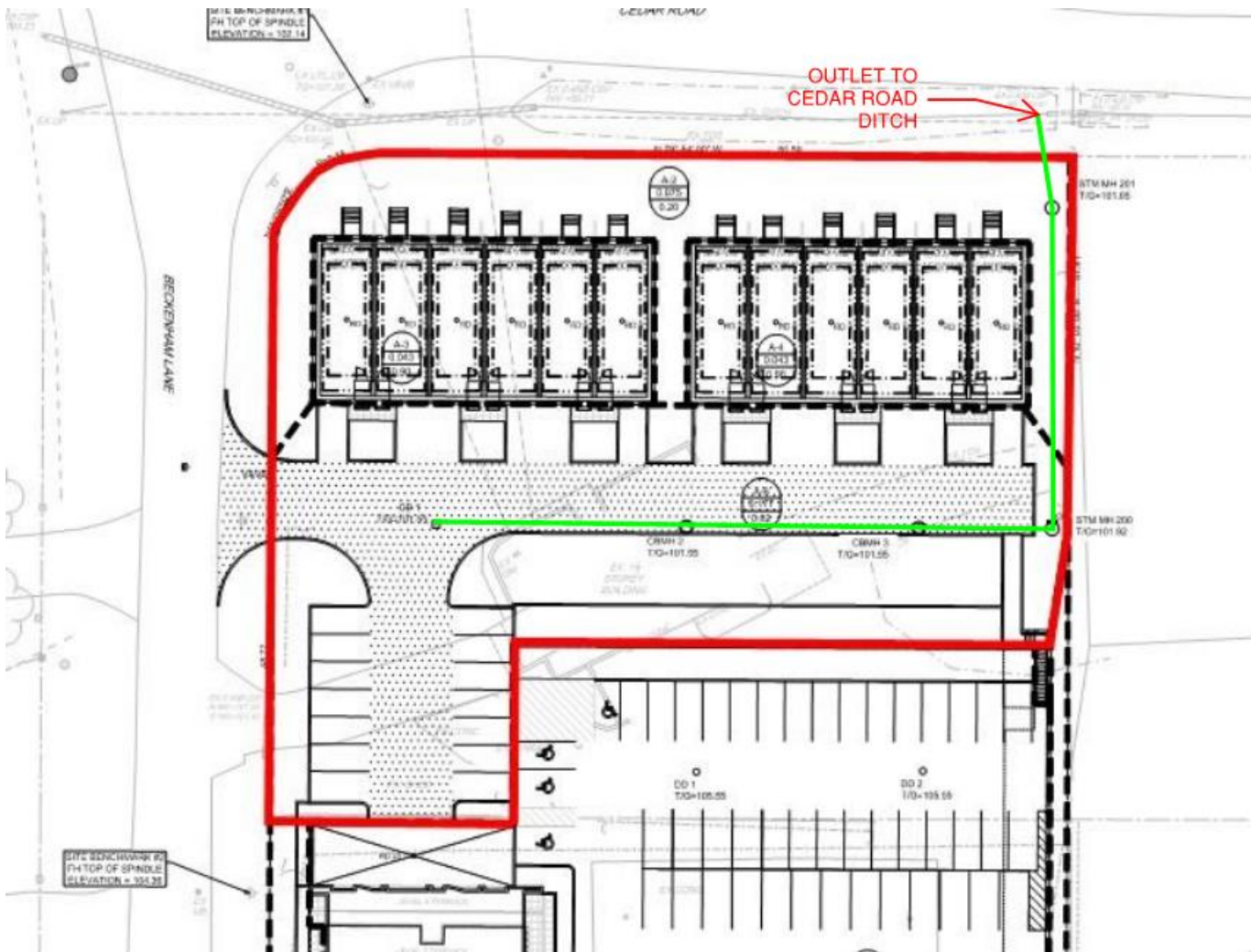

Regards,

**Miroslav Savic**, P.Eng., Senior Project Manager | Land Development Engineering

**NOVATECH** Engineers, Planners & Landscape Architects

240 Michael Cowpland Drive, Suite 200, Ottawa, ON, K2M 1P6 | Tel: 613.254.9643 x 265 | Fax: 613.254.5867

The information contained in this email message is confidential and is for exclusive use of the addressee.

**From:** Jamie Batchelor <[jamie.batchelor@rvca.ca](mailto:jamie.batchelor@rvca.ca)>

**Sent:** Monday, December 12, 2022 9:09 AM

**To:** Miro Savic <[m.savic@novatech-eng.com](mailto:m.savic@novatech-eng.com)>

**Cc:** Larry Colbran <[l.colbran@novatech-eng.com](mailto:l.colbran@novatech-eng.com)>

**Subject:** RE: 1765 Montreal Road - RVCA Pre-Consultation

Good Morning Miro,

Based on the amount of parking spaces and the distance to a downstream outlet, on-site water quality control of enhanced (80% TSS Removal) would be required. Please note, that it was assumed that the downstream outlet is on Blair Road, see snap shot below. Based on the City of Ottawa storm sewer layer, there is an outlet at this location. While there is no arrow indicating direction of flows, it is assumed that storm water would be directed to this outlet given that there is no other source feeding into it. However, if you have any information to suggest otherwise, we'd be happy to further discuss.

RVCA GeoPortal

https://gis.rvca.ca/html5/?viewer=rvcageoportal\_staff#

ComVida | RVCA - Welcome C... | Mail - Jamie Batche... | GeoPortal - No Ott... | GeoPortal - Ottawa...

RVCA TOOLS | GETTING AROUND | COORDINATES | **TASKS** | ANALYSIS

Print | Export | Share | Upload Data | Add Layers | View My Content | Point | Export Drawings | Edit | Erase | Clear

Layers

RVCA

Filter Layers... Filter

terrains du domaine public

- Ottawa Wastewater Infrastructure
- Ottawa Storm Water
  - Storm Water Management
  - Storm Outlet
  - Storm Combined Pipe
    - Combined Pipe
    - Storm Pipe
- Ottawa Surface Water
- Ottawa Administrative Areas
- Ottawa Zoning
- Ottawa Planning
- Community Design Plans / Plans de conception

Home | Layers

LIQ Base

I want to...

ENIGMA PVT

BLAIR RD

DUNHAM ST

STEEL ST

CORLISS ST

CLAVER ST

LOT 21 CON 1 ON OTTAWA RIVER

LOT 20 CON 1 ON

0 50 100m

Jamie Batchelor, MCIP, RPP  
 Planner, ext. 1191



3889 Rideau Valley Drive  
PO Box 599, Manotick ON K4M 1A5  
T 613-692-3571 | 1-800-267-3504 F 613-692-0831 | [www.rvca.ca](http://www.rvca.ca)

This message may contain information that is privileged or confidential and is intended to be for the use of the individual(s) or entity named. If you are not the intended recipient of this e-mail, any use, review, revision, retransmission, distribution, dissemination, copying, printing or taking of any action in reliance upon this e-mail, is strictly prohibited. If you have received this e-mail in error, please contact the sender and any copy of the e-mail and any printout thereof, immediately. Your cooperation is appreciated.

---

**From:** Miro Savic <[m.savic@novatech-eng.com](mailto:m.savic@novatech-eng.com)>  
**Sent:** Tuesday, December 6, 2022 9:38 AM  
**To:** Jamie Batchelor <[jamie.batchelor@rvca.ca](mailto:jamie.batchelor@rvca.ca)>  
**Cc:** Larry Colbran <[l.colbran@novatech-eng.com](mailto:l.colbran@novatech-eng.com)>  
**Subject:** 1765 Montreal Road - RVCA Pre-Consultation

Hello Jamie,

We are working on servicing and stormwater management design for a residential development located at 1765 Montreal Road in the City of Ottawa. The proposed development will consist of a 9-storey apartment building and two townhouse blocks replacing the existing single-family homes. Refer to the attached preliminary site plan for details.

The storm drainage from the 9-store apartment building and the proposed parking lot will be directed to the existing 300mm diameter storm sewer in Montreal Road. The storm drainage from the townhouses and associated driveway will be directed to the Cedar Road roadside ditch

The stormwater quantity control will be provided by controlling the post development flows from the site up to and including 100-year design event to a target 5-year release rate specified by the City of Ottawa.

Can you please confirm whether the storm water quality control is required for the proposed development.



Regards,

**Miroslav Savic**, P.Eng., Senior Project Manager | Land Development Engineering

**NOVATECH** Engineers, Planners & Landscape Architects

240 Michael Cowpland Drive, Suite 200, Ottawa, ON, K2M 1P6 | Tel: 613.254.9643 x 265 | Fax: 613.254.5867

The information contained in this email message is confidential and is for exclusive use of the addressee.

**APPENDIX B**  
**Development Servicing Study Checklist**



## Servicing study guidelines for development applications

### 4. Development Servicing Study Checklist

The following section describes the checklist of the required content of servicing studies. It is expected that the proponent will address each one of the following items for the study to be deemed complete and ready for review by City of Ottawa Infrastructure Approvals staff.

The level of required detail in the Servicing Study will increase depending on the type of application. For example, for Official Plan amendments and re-zoning applications, the main issues will be to determine the capacity requirements for the proposed change in land use and confirm this against the existing capacity constraint, and to define the solutions, phasing of works and the financing of works to address the capacity constraint. For subdivisions and site plans, the above will be required with additional detailed information supporting the servicing within the development boundary.

#### 4.1 General Content

- Executive Summary (for larger reports only).
- Date and revision number of the report.
- Location map and plan showing municipal address, boundary, and layout of proposed development.
- Plan showing the site and location of all existing services.
- Development statistics, land use, density, adherence to zoning and official plan, and reference to applicable subwatershed and watershed plans that provide context to which individual developments must adhere.
- Summary of Pre-consultation Meetings with City and other approval agencies.
- Reference and confirm conformance to higher level studies and reports (Master Servicing Studies, Environmental Assessments, Community Design Plans), or in the case where it is not in conformance, the proponent must provide justification and develop a defensible design criteria.
- Statement of objectives and servicing criteria.
- Identification of existing and proposed infrastructure available in the immediate area.
- Identification of Environmentally Significant Areas, watercourses and Municipal Drains potentially impacted by the proposed development (Reference can be made to the Natural Heritage Studies, if available).
- Concept level master grading plan to confirm existing and proposed grades in the development. This is required to confirm the feasibility of proposed stormwater management and drainage, soil removal and fill constraints, and potential impacts to neighbouring properties. This is also required to confirm that the proposed grading will not impede existing major system flow paths.
- Identification of potential impacts of proposed piped services on private services (such as wells and septic fields on adjacent lands) and mitigation required to address potential impacts.
- Proposed phasing of the development, if applicable.

- Reference to geotechnical studies and recommendations concerning servicing.
- All preliminary and formal site plan submissions should have the following information:
  - Metric scale
  - North arrow (including construction North)
  - Key plan
  - Name and contact information of applicant and property owner
  - Property limits including bearings and dimensions
  - Existing and proposed structures and parking areas
  - Easements, road widening and rights-of-way
  - Adjacent street names

#### **4.2 Development Servicing Report: Water**

- Confirm consistency with Master Servicing Study, if available
- Availability of public infrastructure to service proposed development
- Identification of system constraints
- Identify boundary conditions
- Confirmation of adequate domestic supply and pressure
- Confirmation of adequate fire flow protection and confirmation that fire flow is calculated as per the Fire Underwriter's Survey. Output should show available fire flow at locations throughout the development.
- Provide a check of high pressures. If pressure is found to be high, an assessment is required to confirm the application of pressure reducing valves.
- Definition of phasing constraints. Hydraulic modeling is required to confirm servicing for all defined phases of the project including the ultimate design
- Address reliability requirements such as appropriate location of shut-off valves
- Check on the necessity of a pressure zone boundary modification.
- Reference to water supply analysis to show that major infrastructure is capable of delivering sufficient water for the proposed land use. This includes data that shows that the expected demands under average day, peak hour and fire flow conditions provide water within the required pressure range

- Description of the proposed water distribution network, including locations of proposed connections to the existing system, provisions for necessary looping, and appurtenances (valves, pressure reducing valves, valve chambers, and fire hydrants) including special metering provisions.
- Description of off-site required feeder mains, booster pumping stations, and other water infrastructure that will be ultimately required to service proposed development, including financing, interim facilities, and timing of implementation.
- Confirmation that water demands are calculated based on the City of Ottawa Design Guidelines.
- Provision of a model schematic showing the boundary conditions locations, streets, parcels, and building locations for reference.

### **4.3 Development Servicing Report: Wastewater**

- Summary of proposed design criteria (Note: Wet-weather flow criteria should not deviate from the City of Ottawa Sewer Design Guidelines. Monitored flow data from relatively new infrastructure cannot be used to justify capacity requirements for proposed infrastructure).
- Confirm consistency with Master Servicing Study and/or justifications for deviations.
- Consideration of local conditions that may contribute to extraneous flows that are higher than the recommended flows in the guidelines. This includes groundwater and soil conditions, and age and condition of sewers.
- Description of existing sanitary sewer available for discharge of wastewater from proposed development.
- Verify available capacity in downstream sanitary sewer and/or identification of upgrades necessary to service the proposed development. (Reference can be made to previously completed Master Servicing Study if applicable)
- Calculations related to dry-weather and wet-weather flow rates from the development in standard MOE sanitary sewer design table (Appendix 'C') format.
- Description of proposed sewer network including sewers, pumping stations, and forcemains.
- Discussion of previously identified environmental constraints and impact on servicing (environmental constraints are related to limitations imposed on the development in order to preserve the physical condition of watercourses, vegetation, soil cover, as well as protecting against water quantity and quality).
- Pumping stations: impacts of proposed development on existing pumping stations or requirements for new pumping station to service development.
- Forcemain capacity in terms of operational redundancy, surge pressure and maximum flow velocity.
- Identification and implementation of the emergency overflow from sanitary pumping stations in relation to the hydraulic grade line to protect against basement flooding.
- Special considerations such as contamination, corrosive environment etc.

#### 4.4 Development Servicing Report: Stormwater Checklist

- Description of drainage outlets and downstream constraints including legality of outlets (i.e. municipal drain, right-of-way, watercourse, or private property)
- Analysis of available capacity in existing public infrastructure.
- A drawing showing the subject lands, its surroundings, the receiving watercourse, existing drainage patterns, and proposed drainage pattern.
- Water quantity control objective (e.g. controlling post-development peak flows to pre-development level for storm events ranging from the 2 or 5 year event (dependent on the receiving sewer design) to 100 year return period); if other objectives are being applied, a rationale must be included with reference to hydrologic analyses of the potentially affected subwatersheds, taking into account long-term cumulative effects.
- Water Quality control objective (basic, normal or enhanced level of protection based on the sensitivities of the receiving watercourse) and storage requirements.
- Description of the stormwater management concept with facility locations and descriptions with references and supporting information.
- Set-back from private sewage disposal systems.
- Watercourse and hazard lands setbacks.
- Record of pre-consultation with the Ontario Ministry of Environment and the Conservation Authority that has jurisdiction on the affected watershed.
- Confirm consistency with sub-watershed and Master Servicing Study, if applicable study exists.
- Storage requirements (complete with calculations) and conveyance capacity for minor events (1:5 year return period) and major events (1:100 year return period).
- Identification of watercourses within the proposed development and how watercourses will be protected, or, if necessary, altered by the proposed development with applicable approvals.
- Calculate pre and post development peak flow rates including a description of existing site conditions and proposed impervious areas and drainage catchments in comparison to existing conditions.
- Any proposed diversion of drainage catchment areas from one outlet to another.
- Proposed minor and major systems including locations and sizes of stormwater trunk sewers, and stormwater management facilities.
- If quantity control is not proposed, demonstration that downstream system has adequate capacity for the post-development flows up to and including the 100 year return period storm event.
- Identification of potential impacts to receiving watercourses
- Identification of municipal drains and related approval requirements.
- Descriptions of how the conveyance and storage capacity will be achieved for the development.
- 100 year flood levels and major flow routing to protect proposed development from flooding for establishing minimum building elevations (MBE) and overall grading.

- Inclusion of hydraulic analysis including hydraulic grade line elevations.
- Description of approach to erosion and sediment control during construction for the protection of receiving watercourse or drainage corridors.
- Identification of floodplains – proponent to obtain relevant floodplain information from the appropriate Conservation Authority. The proponent may be required to delineate floodplain elevations to the satisfaction of the Conservation Authority if such information is not available or if information does not match current conditions.
- Identification of fill constraints related to floodplain and geotechnical investigation.

#### **4.5 Approval and Permit Requirements: Checklist**

The Servicing Study shall provide a list of applicable permits and regulatory approvals necessary for the proposed development as well as the relevant issues affecting each approval. The approval and permitting shall include but not be limited to the following:

- Conservation Authority as the designated approval agency for modification of floodplain, potential impact on fish habitat, proposed works in or adjacent to a watercourse, cut/fill permits and Approval under Lakes and Rivers Improvement Act. The Conservation Authority is not the approval authority for the Lakes and Rivers Improvement Act. Where there are Conservation Authority regulations in place, approval under the Lakes and Rivers Improvement Act is not required, except in cases of dams as defined in the Act.
- Application for Certificate of Approval (CofA) under the Ontario Water Resources Act.
- Changes to Municipal Drains.
- Other permits (National Capital Commission, Parks Canada, Public Works and Government Services Canada, Ministry of Transportation etc.)

#### **4.6 Conclusion Checklist**

- Clearly stated conclusions and recommendations
- Comments received from review agencies including the City of Ottawa and information on how the comments were addressed. Final sign-off from the responsible reviewing agency.
- All draft and final reports shall be signed and stamped by a professional Engineer registered in Ontario

**APPENDIX C**  
**Sanitary Sewer Calculations**



PROJECT # : 121060  
DESIGNED BY : LSC  
CHECKED BY : MS  
DATE PREPARED : Dec. 2022

**SANITARY SEWER DESIGN SHEET**  
1765 Montreal Road, City of Ottawa



LOCATION				RESIDENTIAL								PARK		INFILTRATION			FLOW		PROPOSED SEWER								
				INDIVIDUAL				CUMULATIVE				PARK		PARK FLOW Qc(p) (L/s)	Total Area (ha.)	Accu. Total AREA (ha.)	PEAK EXTRAN. FLOW Q(i) (L/s)	PEAK DESIGN FLOW Q(d) (L/s)	LENGTH (m)	PIPE SIZE (mm)	PIPE ID (mm)	TYPE OF PIPE	GRADE %	CAPACITY (L/s)	FULL FLOW VELOCITY	Qpeak/ Qcap	
STREET	FROM MH	TO MH	Area ID	Units	Town/ Semi	Population (in 1000's)	AREA (ha.)	Population (in 1000's)	AREA (ha.)	PEAK FACTOR	POPULATION FLOW Qr(p)	AREA (ha.)	Accu. AREA														LENGTH (m)
Townhouse Access	101	102	A1		12	0.032	0.33	0.032	0.33	3.7	0.39		0.00	0.00	0.33	0.33	0.11	0.50	65.0	200	203.20	DR 35	0.65	27.6	0.85	1.8%	
Townhouse Access	102	103				0.000		0.032	0.33	3.7	0.39		0.00	0.00	0.00	0.33	0.11	0.50	6.0	200	203.20	DR 35	0.65	27.6	0.85	1.8%	
Residential Structure	104	105	A2	159		0.253	0.47	0.285	0.80	3.5	3.21		0.00	0.00	0.47	0.80	0.26	3.47	18.1	200	203.20	DR 35	0.50	24.2	0.75	14.4%	
Montreal Road	105	Ex Sanmh	A3			0.000	0.05	0.285	0.85	3.5	3.21		0.00	0.00	0.05	0.85	0.28	3.49	30.5	200	203.20	DR 35	0.50	24.2	0.75	14.4%	
<b>Total Flows</b>				<b>159</b>	<b>12</b>									<b>0.00</b>			<b>#REF!</b>	<b>#REF!</b>									

**Notes:**  
1. Q(d) = Qr(p) + Q(i) + Qc(p)  
2. Q(i) = 0.33 L/sec/ha  
3. Qr(p) = (PxqxM/86,400)  
3. Qc(p) = (A\*q\*Pf)/86,400

**Definitions:**  
Q(d) = Design Flow (L/sec)  
Qr(p) = Population Flow (L/sec), Residential  
Q(i) = Extraneous Flow (L/sec)  
Qc(p) = Population Flow (L/sec), Commercial/Institutional/Park

P = Population (2.7 persons per townhouse unit)  
Refer to 121060-Sanitary Flow for unit population breakdown per unit type of Residential Structure  
M = Harmon Formula (maximum of 4.0), K = Correction Factor = 0.8  
Mannings n = 0.013



## **APPENDIX D**

### **Water Demands, FUS Calculations and City of Ottawa Boundary Conditions**

# 1765 MONTREAL ROAD

## WATER ANALYSIS

### 9-STOREY HIGHRISE BUILDING WATER DEMAND

Number of 1 Bedroom Units	61
Persons per 1bdr Unit	1.4
Number of 1 Bedroom + Den Units	51
Persons per 1bdr + Den Unit	1.4
Number of Studio Units	4
Persons per 1bdr Unit	1.4
Number of 2 Bedroom Units	43
Persons per 1bdr Unit	2.1
Total Population	253
Average Day Demand per Person	350 L/c/day
Average Day Demand	1.02 L/s
Maximum Day Demand (2.5 x avg. day)	2.56 L/s
Peak Hour Demand (2.2 x avg. day)	5.64 L/s

### 3-STOREY TOWNHOUSES WATER DEMAND

Number of Units	12
Persons per Unit	2.7
Total Population	33
Average Day Demand per Person	350 L/c/day
Average Day Demand	0.13 L/s
Maximum Day Demand (2.5 x avg. day)	0.33 L/s
Peak Hour Demand (2.2 x avg. day)	0.74 L/s

### BOUNDARY CONDITIONS

Maximum HGL =	143 m
Minimum HGL =	142.6 m
Max Day + Fire Flow (67 l/s) =	139.6 m
Max Day + Fire Flow (217 l/s) =	117 m

### **PRESSURE TESTS (9-STOREY BUILDING)**

AVERAGE GROUND ELEVATION 105.5 m

HIGH PRESSURE TEST = MAX HGL - AVG GROUND ELEV x 1.42197 PSI/m < 80 PSI

HIGH PRESSURE = **53.3** PSI

LOW PRESSURE TEST = MIN HGL - AVG GROUND ELEV x 1.42197 PSI/m > 40 PSI

LOW PRESSURE = **52.8** PSI

MAX DAY + FIRE FLOW TEST = MAX DAY + FIRE - AVG GROUND ELEV x 1.42197 PSI/m > 20 PSI

MAX DAY + FIRE PRESSURE = **48.5** PSI

### **PRESSURE TESTS (TOWNHOUSES)**

AVERAGE GROUND ELEVATION 101.7 m

HIGH PRESSURE TEST = MAX HGL - AVG GROUND ELEV x 1.42197 PSI/m < 80 PSI

HIGH PRESSURE = **58.7** PSI

LOW PRESSURE TEST = MIN HGL - AVG GROUND ELEV x 1.42197 PSI/m > 40 PSI

LOW PRESSURE = **58.2** PSI

MAX DAY + FIRE FLOW TEST = MAX DAY + FIRE - AVG GROUND ELEV x 1.42197 PSI/m > 20 PSI

MAX DAY + FIRE PRESSURE = **21.8** PSI

# FUS - Fire Flow Calculations

As per 2020 Fire Underwriter's Survey Guidelines



Engineers, Planners & Landscape Architects

Novatech Project #: 121060  
 Project Name: 1765 Montreal Road  
 Date: 11/18/2022  
 Input By: M.Savic  
 Reviewed By:

Legend

Input by User  
 No Information or Input Required

Building Description: 9-Storey Apartment Building  
 Type I - Fire resistive construction (2 hrs)

Step		Choose		Value Used	Total Fire Flow (L/min)	
<b>Base Fire Flow</b>						
1	<b>Construction Material</b>		<b>Multiplier</b>		0.6	
	<b>Coefficient related to type of construction</b> <b>C</b>	Type V - Wood frame		1.5		
		Type IV - Mass Timber		Varies		
		Type III - Ordinary construction		1		
		Type II - Non-combustible construction		0.8		
Type I - Fire resistive construction (2 hrs)		Yes	0.6			
2	<b>Floor Area</b>				7,000	
	<b>A</b>	Building Footprint (m <sup>2</sup> )	1647			
		Number of Floors/Storeys	9			
		Protected Openings (1 hr)	Yes			
		Area of structure considered (m <sup>2</sup> )		2,471		
<b>F</b>	<b>Base fire flow without reductions</b>					
	<b>F = 220 C (A)<sup>0.5</sup></b>					
<b>Reductions or Surcharges</b>						
3	<b>Occupancy hazard reduction or surcharge</b>		<b>FUS Table 3</b>	<b>Reduction/Surcharge</b>	5,950	
	<b>(1)</b>	Non-combustible		-25%		
		Limited combustible	Yes	-15%		
		Combustible		0%		
		Free burning		15%		
Rapid burning			25%			
4	<b>Sprinkler Reduction</b>		<b>FUS Table 4</b>	<b>Reduction</b>	-2,380	
	<b>(2)</b>	Adequately Designed System (NFPA 13)	Yes	-30%		
		Standard Water Supply	Yes	-10%		
		Fully Supervised System		-10%		
		<b>Cumulative Sub-Total</b>				-40%
	<b>Area of Sprinklered Coverage (m<sup>2</sup>)</b>		100%			
	<b>Cumulative Total</b>		-40%			
5	<b>Exposure Surcharge</b>		<b>FUS Table 5</b>	<b>Surcharge</b>	595	
	<b>(3)</b>	North Side	>30m	0%		
		East Side	20.1 - 30 m	10%		
		South Side	>30m	0%		
		West Side	>30m	0%		
	<b>Cumulative Total</b>		10%			
<b>Results</b>						
6	<b>(1) + (2) + (3)</b>	<b>Total Required Fire Flow, rounded to nearest 1000L/min</b>		<b>L/min</b>	<b>4,000</b>	
		(2,000 L/min < Fire Flow < 45,000 L/min)		or	<b>L/s</b>	<b>67</b>
				or	<b>USGPM</b>	<b>1,057</b>

# FUS - Fire Flow Calculations

As per 2020 Fire Underwriter's Survey Guidelines



Novatech Project #: 121060  
 Project Name: 1675 Montreal Road  
 Date: 11/22/2022  
 Input By: Miro Savic  
 Reviewed By:

Legend  
 Input by User  
 No Information or Input Required

Building Description: 3 Storey Townhouse (North West)  
 Type V - Wood frame

Step	Input		Value Used	Total Fire Flow (L/min)		
<b>Base Fire Flow</b>						
1	<b>Construction Material</b>		<b>Multiplier</b>			
	<b>Coefficient related to type of construction</b> <b>C</b>	Type V - Wood frame	Yes	1.5	1.5	
		Type IV - Mass Timber		Varies		
		Type III - Ordinary construction		1		
		Type II - Non-combustible construction		0.8		
Type I - Fire resistive construction (2 hrs)			0.6			
2	<b>Floor Area</b>					
	<b>A</b>	Building Footprint (m <sup>2</sup> )	437	1,311		
		Number of Floors/Storeys	3			
		Area of structure considered (m <sup>2</sup> )				
<b>F</b>	Base fire flow without reductions		12,000			
		$F = 220 C (A)^{0.5}$				
<b>Reductions or Surcharges</b>						
3	<b>Occupancy hazard reduction or surcharge</b>		<b>FUS Table 3</b>	<b>Reduction/Surcharge</b>		
	<b>(1)</b>	Non-combustible		-25%	-15%	
		Limited combustible	Yes	-15%		
		Combustible		0%		
		Free burning		15%		
Rapid burning			25%			
4	<b>Sprinkler Reduction</b>		<b>FUS Table 4</b>	<b>Reduction</b>		
	<b>(2)</b>	Adequately Designed System (NFPA 13)		-30%	0	
		Standard Water Supply		-10%		
		Fully Supervised System		-10%		
		<b>Cumulative Sub-Total</b>		<b>0%</b>		
Area of Sprinklered Coverage (m <sup>2</sup> )			0%			
<b>Cumulative Total</b>		<b>0%</b>				
5	<b>Exposure Surcharge</b>		<b>FUS Table 5</b>	<b>Surcharge</b>		
	<b>(3)</b>	North Side	>30m	0%	2,550	
		East Side	0 - 3 m	25%		
		South Side	>30m	0%		
		West Side	>30m	0%		
<b>Cumulative Total</b>		<b>25%</b>				
<b>Results</b>						
6	<b>(1) + (2) + (3)</b>	<b>Total Required Fire Flow, rounded to nearest 1000L/min</b>		<b>L/min</b>	<b>13,000</b>	
		(2,000 L/min < Fire Flow < 45,000 L/min)		or	L/s	217
				or	USGPM	3,435

# FUS - Fire Flow Calculations

As per 2020 Fire Underwriter's Survey Guidelines



Novatech Project #: 121060  
 Project Name: 1675 Montreal Road  
 Date: 11/22/2022  
 Input By: Miro Savic  
 Reviewed By:

Legend  
 Input by User  
 No Information or Input Required

Building Description: 3 Storey Townhouse (North East)  
 Type V - Wood Frame with Fire Wall

Step	Input		Value Used	Total Fire Flow (L/min)	
<b>Base Fire Flow</b>					
1	<b>Construction Material</b>		<b>Multiplier</b>	1.5	
	<b>Coefficient related to type of construction</b> <b>C</b>	Type V - Wood frame	Yes		1.5
		Type IV - Mass Timber			Varies
		Type III - Ordinary construction			1
		Type II - Non-combustible construction			0.8
Type I - Fire resistive construction (2 hrs)			0.6		
2	<b>Floor Area</b>		656	8,000	
	<b>A</b>	Building Footprint (m <sup>2</sup> )			218.5
		Number of Floors/Storeys			3
		Area of structure considered (m <sup>2</sup> )			
<b>F</b>	Base fire flow without reductions				
<b>Reductions or Surcharges</b>					
3	<b>Occupancy hazard reduction or surcharge</b>		<b>FUS Table 3</b>	<b>Reduction/Surcharge</b>	
	<b>(1)</b>	Non-combustible		-25%	
		Limited combustible	Yes	-15%	
		Combustible		0%	
		Free burning		15%	
Rapid burning			25%		
4	<b>Sprinkler Reduction</b>		<b>FUS Table 4</b>	<b>Reduction</b>	
	<b>(2)</b>	Adequately Designed System (NFPA 13)		-30%	
		Standard Water Supply		-10%	
		Fully Supervised System		-10%	
		<b>Cumulative Sub-Total</b>		<b>0%</b>	
Area of Sprinklered Coverage (m <sup>2</sup> )			0%		
<b>Cumulative Total</b>		<b>0%</b>			
5	<b>Exposure Surcharge</b>		<b>FUS Table 5</b>	<b>Surcharge</b>	
	<b>(3)</b>	North Side	>30m	0%	
		East Side	0 - 3 m	25%	
		South Side	>30m	0%	
		West Side	2Hr Firewall	0%	
<b>Cumulative Total</b>		<b>25%</b>			
<b>Results</b>					
6	<b>(1) + (2) + (3)</b>	<b>Total Required Fire Flow, rounded to nearest 1000L/min</b>		<b>L/min</b>	
		(2,000 L/min < Fire Flow < 45,000 L/min)		<b>9,000</b>	
		or	L/s	<b>150</b>	
		or	USGPM	<b>2,378</b>	

## Miro Savic

---

**From:** Rasool, Rubina <Rubina.Rasool@ottawa.ca>  
**Sent:** Monday, December 19, 2022 7:54 AM  
**To:** Miro Savic  
**Subject:** RE: 1765 Montreal Road - Boundary Conditions Request  
**Attachments:** 1765 Montreal Road December 2022.pdf

Hi Miro,

Please see below the WBC.

Best,

**\*\*\*\*The following information may be passed on to the consultant, but do NOT forward this e-mail directly.\*\*\*\***

The following are boundary conditions, HGL, for hydraulic analysis at 1765 Montreal Road (zone MONT) with an assumed connection to the 203 mm watermain on Beckenham Lane (see attached PDF for location).

Minimum HGL: 142.6 m

Maximum HGL: 143.0 m

Max Day + Fire Flow (67 L/s): 139.6 m (Connection 1)

Max Day + Fire Flow (217 L/s): 117.0 m (Connection 2)

**The three hydrants in proximity to the north-east townhouse building are not sufficient to supply the required fire demand of 233 L/s.**

These are for current conditions and are based on computer model simulation.

*Disclaimer: The boundary condition information is based on current operation of the city water distribution system. The computer model simulation is based on the best information available at the time. The operation of the water distribution system can change on a regular basis, resulting in a variation in boundary conditions. The physical properties of watermains deteriorate over time, as such must be assumed in the absence of actual field test data. The variation in physical watermain properties can therefore alter the results of the computer model simulation.*

**Rubina**

---

**Rubina Rasool, E.I.T.**

Project Manager

Planning, Infrastructure and Economic Development Department - Services de la planification, de l'infrastructure et du développement économique

Development Review – East Branch

City of Ottawa | Ville d'Ottawa

110 Laurier Avenue West Ottawa, ON | 110, avenue Laurier Ouest. Ottawa (Ontario) K1P 1J1 [rubina.rasool@ottawa.ca](mailto:rubina.rasool@ottawa.ca)

---

**From:** Rasool, Rubina  
**Sent:** December 12, 2022 6:34 AM  
**To:** Miro Savic <[m.savic@novatech-eng.com](mailto:m.savic@novatech-eng.com)>  
**Subject:** RE: 1765 Montreal Road - Boundary Conditions Request

Hello Miro,

I have followed-up on the request. I will hopefully receive the request soon.

Best,

**Rubina**

---

**Rubina Rasool, E.I.T.**

Project Manager

Planning, Infrastructure and Economic Development Department - Services de la planification, de l'infrastructure et du développement économique

Development Review – East Branch

City of Ottawa | Ville d'Ottawa

110 Laurier Avenue West Ottawa, ON | 110, avenue Laurier Ouest. Ottawa (Ontario) K1P 1J1 [rubina.rasool@ottawa.ca](mailto:rubina.rasool@ottawa.ca)

---

**From:** Miro Savic <[m.savic@novatech-eng.com](mailto:m.savic@novatech-eng.com)>  
**Sent:** December 09, 2022 2:48 PM  
**To:** Rasool, Rubina <[Rubina.Rasool@ottawa.ca](mailto:Rubina.Rasool@ottawa.ca)>  
**Subject:** RE: 1765 Montreal Road - Boundary Conditions Request

**CAUTION: This email originated from an External Sender. Please do not click links or open attachments unless you recognize the source.**

**ATTENTION : Ce courriel provient d'un expéditeur externe. Ne cliquez sur aucun lien et n'ouvrez pas de pièce jointe, excepté si vous connaissez l'expéditeur.**

Could you please follow up on the WBC. We are aiming to submit for SPA next week and need this info asap.

Thanks,

**Miroslav Savic**, P.Eng., Senior Project Manager | Land Development Engineering

**NOVATECH** Engineers, Planners & Landscape Architects

240 Michael Cowpland Drive, Suite 200, Ottawa, ON, K2M 1P6 | Tel: 613.254.9643 x 265 | Fax: 613.254.5867

The information contained in this email message is confidential and is for exclusive use of the addressee.

---

**From:** Rasool, Rubina <[Rubina.Rasool@ottawa.ca](mailto:Rubina.Rasool@ottawa.ca)>  
**Sent:** Monday, November 28, 2022 7:21 AM  
**To:** Miro Savic <[m.savic@novatech-eng.com](mailto:m.savic@novatech-eng.com)>  
**Subject:** RE: 1765 Montreal Road - Boundary Conditions Request

Hi Miro,

I have requested the WBC. Please note it may take 5-10 business days for review.



Best,

**Rubina**

---

**Rubina Rasool, E.I.T.**

Project Manager

Planning, Infrastructure and Economic Development Department - Services de la planification, de l'infrastructure et du développement économique

Development Review – East Branch

City of Ottawa | Ville d'Ottawa

110 Laurier Avenue West Ottawa, ON | 110, avenue Laurier Ouest. Ottawa (Ontario) K1P 1J1 [rubina.rasool@ottawa.ca](mailto:rubina.rasool@ottawa.ca)

---

**From:** Miro Savic <[m.savic@novatech-eng.com](mailto:m.savic@novatech-eng.com)>

**Sent:** November 24, 2022 5:26 PM

**To:** Rasool, Rubina <[Rubina.Rasool@ottawa.ca](mailto:Rubina.Rasool@ottawa.ca)>

**Subject:** 1765 Montreal Road - Boundary Conditions Request

**CAUTION: This email originated from an External Sender. Please do not click links or open attachments unless you recognize the source.**

**ATTENTION : Ce courriel provient d'un expéditeur externe. Ne cliquez sur aucun lien et n'ouvrez pas de pièce jointe, excepté si vous connaissez l'expéditeur.**

I'm writing to request water boundary conditions for the proposed residential development located at 1765 Montreal Road. The proposed development consists of a 9-storey apartment building and two 3-storey townhouses.

The fire flow demands calculated using FUS are as follows:

- 9-storey apartment building: 67 L/s (4,000 L/min)
- 3-Store townhouse (north-east): 233 L/s (14,000 L/min)
- 3-Store townhouse (north-west): 217 L/s (13,000 L/min)
- 

The domestic water demands for the 9-storey apartment building are calculated as follows:

- Average Day Demand: 1.02 L/s
- Maximum Day Demand: 2.56 L/s
- Peak Hour Demand: 5.64 L/s

The domestic water demands for the two 3-storey townhouses are calculated as follows:

- Average Day Demand: 0.13 L/s
- Maximum Day Demand: 0.33 L/s
- Peak Hour Demand: 0.74 L/s

Water services for the 9-storey apartment building and the 3-storey townhouses are proposed to be connected to the existing 203mm watermain in Buckenham Lane. Refer to the attached sketch for approximate service connection locations.

There are five existing hydrants within the 150m of the proposed development. The existing hydrants are shown on the attached sketch

Please let me know if you have any questions or require more information to provide the boundary conditions for the project.

Regards,

**Miroslav Savic**, P.Eng., Senior Project Manager | Land Development Engineering

**NOVATECH** Engineers, Planners & Landscape Architects

240 Michael Cowpland Drive, Suite 200, Ottawa, ON, K2M 1P6 | Tel: 613.254.9643 x 265 | Fax: 613.254.5867

The information contained in this email message is confidential and is for exclusive use of the addressee.

'  
  
This e-mail originates from the City of Ottawa e-mail system. Any distribution, use or copying of this e-mail or the information it contains by other than the intended recipient(s) is unauthorized. Thank you.

Le présent courriel a été expédié par le système de courriels de la Ville d'Ottawa. Toute distribution, utilisation ou reproduction du courriel ou des renseignements qui s'y trouvent par une personne autre que son destinataire prévu est interdite. Je vous remercie de votre collaboration.

'  
  
This e-mail originates from the City of Ottawa e-mail system. Any distribution, use or copying of this e-mail or the information it contains by other than the intended recipient(s) is unauthorized. Thank you.

Le présent courriel a été expédié par le système de courriels de la Ville d'Ottawa. Toute distribution, utilisation ou reproduction du courriel ou des renseignements qui s'y trouvent par une personne autre que son destinataire prévu est interdite. Je vous remercie de votre collaboration.

# Boundary Conditions for 1765 Montreal Road

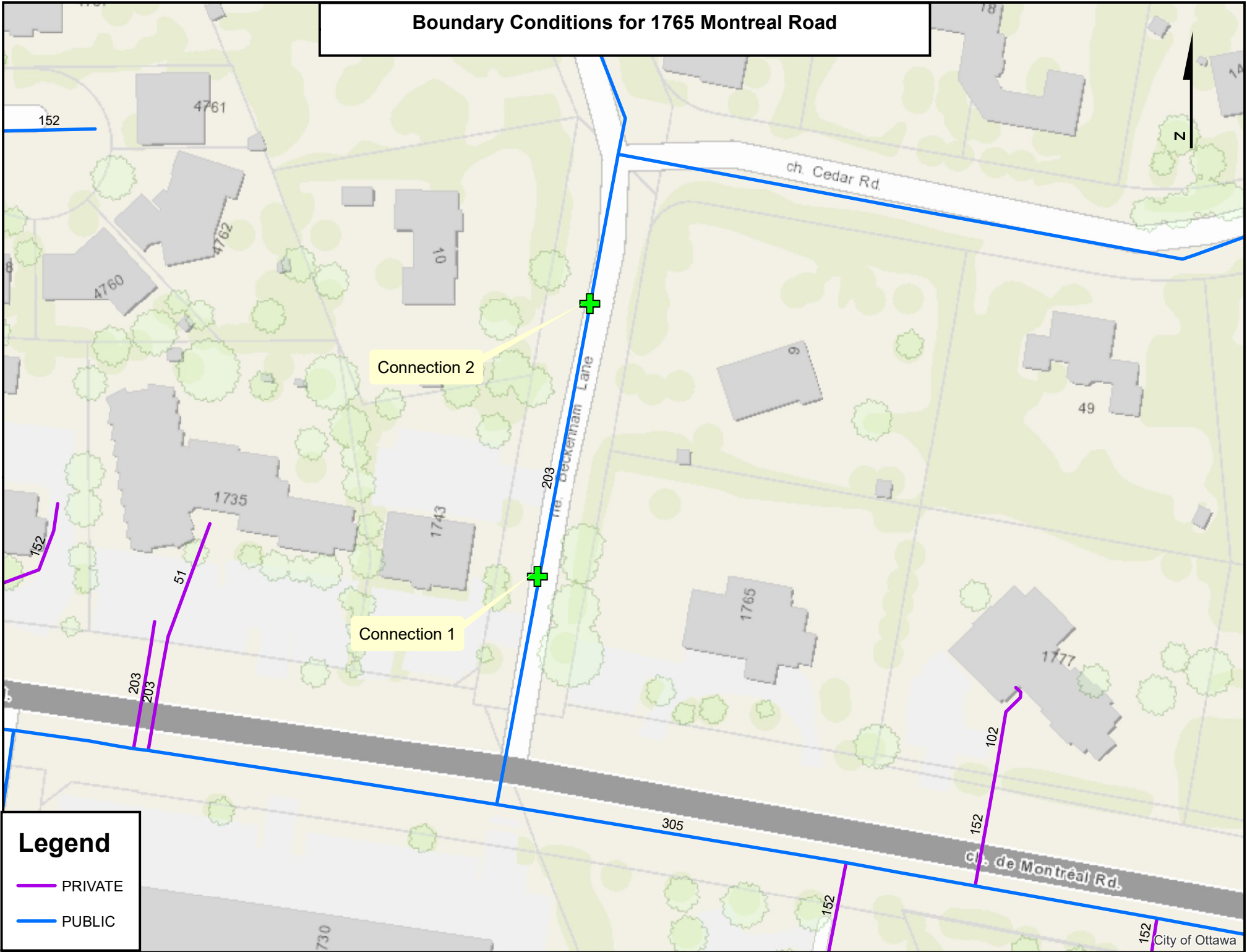

## Miro Savic

---

**From:** Ryan Koolwine <koolwine@project1studio.ca>  
**Sent:** Tuesday, November 22, 2022 2:56 PM  
**To:** Miro Savic; Julien Hebert  
**Subject:** RE: 1765 Montreal Road - Boulding Construction Details for FUS

Hi Miro,

They are the same as I've described below. Let me know if you need more information.

### Ryan Koolwine

project1studio | 613 884-3939 x1

---

**From:** Miro Savic <m.savic@novatech-eng.com>  
**Sent:** November 22, 2022 2:35 PM  
**To:** Ryan Koolwine <koolwine@project1studio.ca>; Julien Hebert <hebert@project1studio.ca>  
**Subject:** RE: 1765 Montreal Road - Boulding Construction Details for FUS

Hi Ryan,

Can you please confirm the building construction details for the townhomes.

Thank you,

**Miroslav Savic**, P.Eng., Senior Project Manager | Land Development Engineering

**NOVATECH** Engineers, Planners & Landscape Architects

240 Michael Cowpland Drive, Suite 200, Ottawa, ON, K2M 1P6 | Tel: 613.254.9643 x 265 | Fax: 613.254.5867

The information contained in this email message is confidential and is for exclusive use of the addressee.

---

**From:** Ryan Koolwine <koolwine@project1studio.ca>  
**Sent:** Monday, September 27, 2021 8:56 AM  
**To:** Miro Savic <m.savic@novatech-eng.com>  
**Cc:** Steve Matthews <S.Matthews@novatech-eng.com>  
**Subject:** RE: 1765 Montreal Road - Building Construction Details for FUS

Hi Miro,

The terminology for this is always a little odd from an architectural perspective. Can you send me the description on the different construction types?

Otherwise, I can tell you the following:

### 9-Storey Apartment Building

- Floor assemblies will have a 2hr fire resistance rating
- Building will be sprinklered
- Steel Structure, all steel columns will be wrapped in an assembly providing a 2hr fire resistance rating
- All suites are separated from each other and the rest of the building by a 1hr fire separation

**Stacked Townhouse**

- Wood construction
- Not Sprinklered
- Fire separations between suites (demising walls and floor separating suites) but otherwise not fire resistive.

If you can provide me with the definitions on the construction types, I can get back to you on this later today.

**Ryan Koolwine**

project1studio | 613 884-3939 x1

---

**From:** Miro Savic <[m.savic@novatech-eng.com](mailto:m.savic@novatech-eng.com)>  
**Sent:** September 23, 2021 2:15 PM  
**To:** Ryan Koolwine <[koolwine@project1studio.ca](mailto:koolwine@project1studio.ca)>  
**Cc:** Steve Matthews <[S.Matthews@novatech-eng.com](mailto:S.Matthews@novatech-eng.com)>  
**Subject:** 1765 Montreal Road - Building Construction Details for FUS

Hi Ryan,

We are preparing the FUS (Fire Underwriters Survey) calculations to provide to the city to obtain water boundary conditions and would like you to confirm some building construction details.

Type of construction:

Will the structure be unprotected concrete/steel, or fire-resistive?

If so, what will it be rated to? (ie 2 hours or 3 hours)

Will the openings between floors have a 1 hour fire rating?

Sprinklers:

Will the building be fully sprinklered?

I assume that stacked townhouses will be wood frame construction with no sprinklers. Please confirm.

Regards,

**Miroslav Savic**, P.Eng., Senior Project Manager | Land Development Engineering

**NOVATECH** Engineers, Planners & Landscape Architects

240 Michael Cowpland Drive, Suite 200, Ottawa, ON, K2M 1P6 | Tel: 613.254.9643 x 265 | Fax: 613.254.5867

The information contained in this email message is confidential and is for exclusive use of the addressee.

## **APPENDIX E**

### **IDF Curves, Pre-Development Drainage Area Plan and SWM Calculations**

Ottawa Sewer Design Guidelines

APPENDIX 5-A

OTTAWA INTENSITY DURATION FREQUENCY (IDF) CURVE

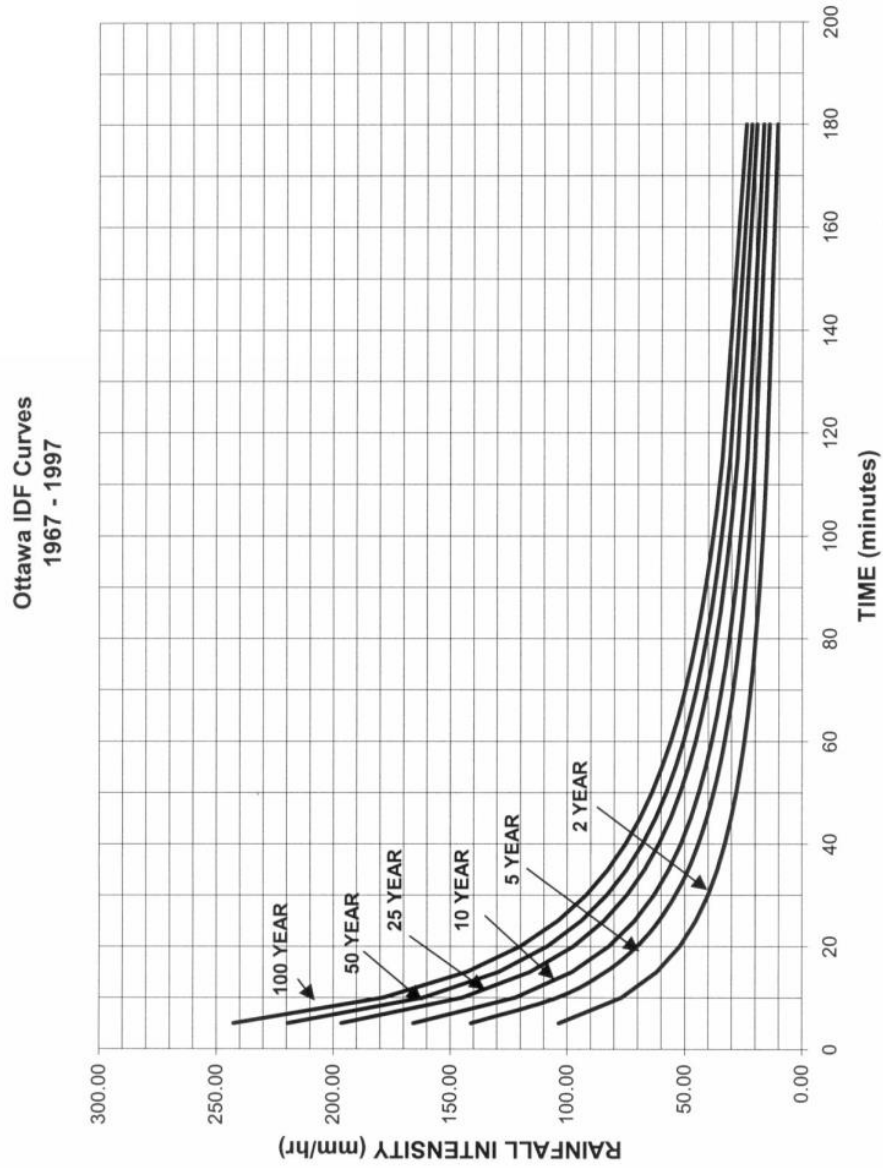

## Proposed Residential Development 1765 Montreal Road

Pre - Development Site Flows									
Description	Area (ha)	$A_{impervious}$ (ha) C=0.9	$A_{pervious}$ (ha) C=0.2	Weighted $C_{w5}$	Weighted $C_{w100}$	1:5 Year Flow (L/s)	1:100 Year Flow (L/s)	Allowable $C_{value}$	Allowable Flow
									5 year (L/s)
Area Draining to Montreal Road	0.165	0.083	0.082	0.55	0.63	23.9	51.5		
Area Draining to Cedar Road Ditch	0.634	0.101	0.533	0.31	0.37	57.2	116.3		
<b>Total Pre Development Flow</b>	<b>0.799</b>	<b>0.184</b>	<b>0.615</b>	<b>0.36</b>	<b>0.42</b>	<b>83.6</b>	<b>167.8</b>	<b>0.50</b>	<b>115.7</b>

$T_c = 10mins$

Post - Development Site Flows												
Area	Description	Area (ha)	$A_{imp}$ (ha) C=0.9	$A_{perv}$ (ha) C=0.2	$C_5$	$C_{100}$	Uncontrolled Flow (L/s)		Controlled Flow (L/s)		Storage Required (m <sup>3</sup> )	
							5 year	100 year	5 year	100 year	5 year	100 year
A-1	Uncontrolled Runoff to Montreal Rd.	0.062	0.025	0.037	0.48	0.55	8.7	17.0	-	-	-	-
A-2	Uncontrolled Runoff to Cedar Road Ditch.	0.075	0.000	0.075	0.20	0.25	4.3	9.3	-	-	-	-
A-3	Controlled Flow from Roof Drain 1-6	0.043	0.043	0.000	0.90	1.00	-	-	1.9	1.9	7.0	17.2
A-4	Controlled Flow from Roof Drain 7-12	0.043	0.043	0.000	0.90	1.00	-	-	1.9	1.9	7.0	17.2
A-5	Controlled Flow from Roof Drain 13-22	0.117	0.117	0.000	0.90	1.00	-	-	6.0	6.5	17.9	43.4
A-6	Uncontrolled Flow from Townhouse Driveways	0.177	0.105	0.072	0.62	0.69	31.5	61.1	-	-	-	-
A-7	Controlled Flow from SWM Tank	0.282	0.243	0.039	0.80	0.90	-	-	15.1	15.1	34.9	90.4
<b>Totals :</b>		<b>0.799</b>	<b>-</b>	<b>-</b>	<b>-</b>	<b>-</b>	<b>44.6</b>	<b>87.4</b>	<b>25.0</b>	<b>25.5</b>	<b>66.8</b>	<b>168.1</b>
							<b>Total Site Flows :</b>		<b>69.5</b>	<b>112.9</b>		

$T_c = 10mins$      $T_c = 10mins$



<b>1765 Montreal Road</b>				
<b>Novatech Project No. 121060</b>				
<b>REQUIRED STORAGE - 1:5 YEAR EVENT</b>				
<b>AREA A-3 Controlled Flow Roof Drain 1-6</b>				
OTTAWA IDF CURVE				
Area =	0.007	ha	Qallow =	0.32 L/s
C =	0.90		Vol(max) =	1.2 m3
Time (min)	Intensity (mm/hr)	Q (L/s)	Qnet (L/s)	Vol (m3)
5	141.18	2.53	2.21	0.66
10	104.19	1.87	1.55	0.93
15	83.56	1.50	1.18	1.06
20	70.25	1.26	0.94	1.13
25	60.90	1.09	0.77	1.16
30	53.93	0.97	0.65	1.16
35	48.52	0.87	0.55	1.15
40	44.18	0.79	0.47	1.13
45	40.63	0.73	0.41	1.10
50	37.65	0.68	0.36	1.07
55	35.12	0.63	0.31	1.02
60	32.94	0.59	0.27	0.97
65	31.04	0.56	0.24	0.92
70	29.37	0.53	0.21	0.87
75	27.89	0.50	0.18	0.81
90	24.29	0.44	0.12	0.62
105	21.58	0.39	0.07	0.42
120	19.47	0.35	0.03	0.21

<b>(6x) WATTS Adjustable Accutrol Weir RD-100-A-ADJ: Weir Setting = Closed</b>					
Design Event	Flow/Drain (L/s)	Total Flow (L/s)	Ponding (cm)	Storage (m <sup>3</sup> )	
				Required	Provided
1:5 Year	0.32	1.92	11	1.2	3.2
1:100 Year	0.32	1.92	14	2.9	

Roof Drain Storage Table for Area A-3		
Elevation	Area RD 1	Total Volume
m	m <sup>2</sup>	m <sup>3</sup>
0.00	0	0
0.05	6.6	0.2
0.10	26.5	1.0
0.15	59.7	3.2

<b>1765 Montreal Road</b>				
<b>Novatech Project No. 121060</b>				
<b>REQUIRED STORAGE - 1:100 YEAR EVENT</b>				
<b>AREA A-3 Controlled Flow Roof Drain 1-6</b>				
OTTAWA IDF CURVE				
Area =	0.007	ha	Qallow =	0.32 L/s
C =	1.00		Vol(max) =	2.9 m3
Time (min)	Intensity (mm/hr)	Q (L/s)	Qnet (L/s)	Vol (m3)
5	242.70	4.84	4.52	1.35
10	178.56	3.56	3.24	1.94
15	142.89	2.85	2.53	2.27
20	119.95	2.39	2.07	2.48
25	103.85	2.07	1.75	2.62
30	91.87	1.83	1.51	2.72
35	82.58	1.65	1.33	2.78
40	75.15	1.50	1.18	2.83
45	69.05	1.38	1.06	2.85
50	63.95	1.27	0.95	2.86
55	59.62	1.19	0.87	2.86
60	55.89	1.11	0.79	2.86
65	52.65	1.05	0.73	2.84
70	49.79	0.99	0.67	2.82
75	47.26	0.94	0.62	2.80
90	41.11	0.82	0.50	2.69
105	36.50	0.73	0.41	2.57
120	32.89	0.66	0.34	2.41

**Stage Storage Curve: Area A-3  
Controlled Roof Drain 1-6**

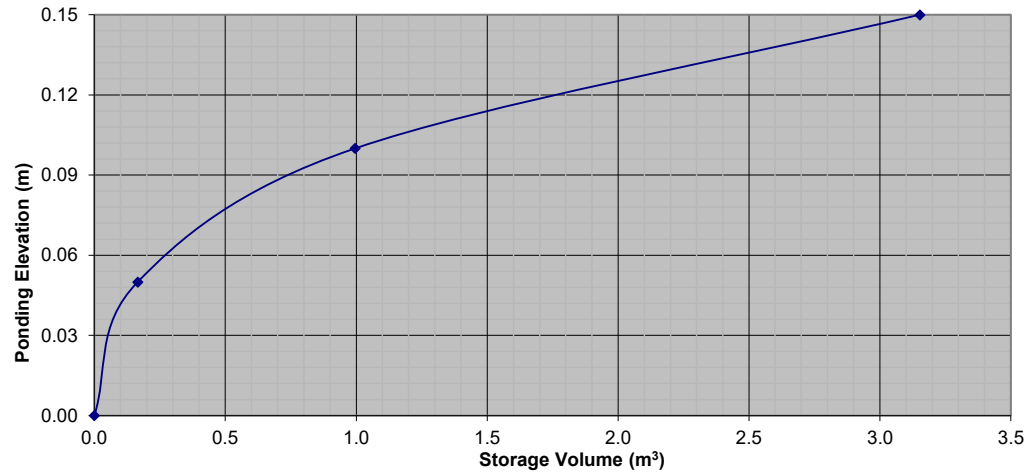

1765 Montreal Road				
Novatech Project No. 121060				
REQUIRED STORAGE - 1:5 YEAR EVENT				
AREA A-4 Controlled Flow Roof Drain 7-12				
OTTAWA IDF CURVE				
Area =	0.007	ha	Qallow =	0.32 L/s
C =	0.90		Vol(max) =	1.2 m3
Time (min)	Intensity (mm/hr)	Q (L/s)	Qnet (L/s)	Vol (m3)
5	141.18	2.53	2.21	0.66
10	104.19	1.87	1.55	0.93
15	83.56	1.50	1.18	1.06
20	70.25	1.26	0.94	1.13
25	60.90	1.09	0.77	1.16
30	53.93	0.97	0.65	1.16
35	48.52	0.87	0.55	1.15
40	44.18	0.79	0.47	1.13
45	40.63	0.73	0.41	1.10
50	37.65	0.68	0.36	1.07
55	35.12	0.63	0.31	1.02
60	32.94	0.59	0.27	0.97
65	31.04	0.56	0.24	0.92
70	29.37	0.53	0.21	0.87
75	27.89	0.50	0.18	0.81
90	24.29	0.44	0.12	0.62
105	21.58	0.39	0.07	0.42
120	19.47	0.35	0.03	0.21

(6x) WATTS Adjustable Accutrol Weir RD-100-A-ADJ: Weir Setting = Closed					
Design Event	Flow/Drain (L/s)	Total Flow (L/s)	Ponding (cm)	Storage (m <sup>3</sup> )	
				Required	Provided
1:5 Year	0.32	1.92	11	1.2	3.2
1:100 Year	0.32	1.92	14	2.9	

Roof Drain Storage Table for Area A-4		
Elevation	Area RD 1	Total Volume
m	m <sup>2</sup>	m <sup>3</sup>
0.00	0	0
0.05	6.6	0.2
0.10	26.5	1.0
0.15	59.7	3.2

1765 Montreal Road				
Novatech Project No. 121060				
REQUIRED STORAGE - 1:100 YEAR EVENT				
AREA A-4 Controlled Flow Roof Drain 7-12				
OTTAWA IDF CURVE				
Area =	0.007	ha	Qallow =	0.32 L/s
C =	1.00		Vol(max) =	2.9 m3
Time (min)	Intensity (mm/hr)	Q (L/s)	Qnet (L/s)	Vol (m3)
5	242.70	4.84	4.52	1.35
10	178.56	3.56	3.24	1.94
15	142.89	2.85	2.53	2.27
20	119.95	2.39	2.07	2.48
25	103.85	2.07	1.75	2.62
30	91.87	1.83	1.51	2.72
35	82.58	1.65	1.33	2.78
40	75.15	1.50	1.18	2.83
45	69.05	1.38	1.06	2.85
50	63.95	1.27	0.95	2.86
55	59.62	1.19	0.87	2.86
60	55.89	1.11	0.79	2.86
65	52.65	1.05	0.73	2.84
70	49.79	0.99	0.67	2.82
75	47.26	0.94	0.62	2.80
90	41.11	0.82	0.50	2.69
105	36.50	0.73	0.41	2.57
120	32.89	0.66	0.34	2.41

Stage Storage Curve: Area A-4  
Controlled Roof Drain 7-12

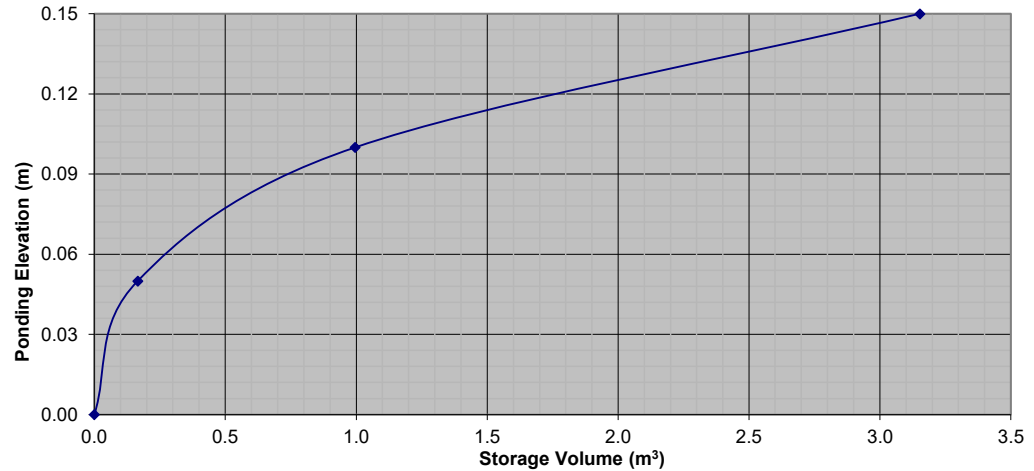

1765 Montreal Road				
Novatech Project No. 121060				
REQUIRED STORAGE - 1:5 YEAR EVENT				
AREA A-5 Controlled Flow Roof Drain 13				
OTTAWA IDF CURVE				
Area =	0.010	ha	Qallow =	0.32 L/s
C =	0.90		Vol(max) =	1.9 m3
Time (min)	Intensity (mm/hr)	Q (L/s)	Qnet (L/s)	Vol (m3)
5	141.18	3.53	3.21	0.96
10	104.19	2.61	2.29	1.37
15	83.56	2.09	1.77	1.59
20	70.25	1.76	1.44	1.73
25	60.90	1.52	1.20	1.81
30	53.93	1.35	1.03	1.85
35	48.52	1.21	0.89	1.88
40	44.18	1.11	0.79	1.89
45	40.63	1.02	0.70	1.88
50	37.65	0.94	0.62	1.87
55	35.12	0.88	0.56	1.84
60	32.94	0.82	0.50	1.82
65	31.04	0.78	0.46	1.78
70	29.37	0.73	0.41	1.74
75	27.89	0.70	0.38	1.70
90	24.29	0.61	0.29	1.55
105	21.58	0.54	0.22	1.39
120	19.47	0.49	0.17	1.20

(6x) WATTS Adjustable Accutrol Weir RD-100-A-ADJ: Weir Setting = Closed					
Design Event	Flow/Drain (L/s)	Total Flow (L/s)	Ponding (cm)	Storage (m <sup>3</sup> )	
				Required	Provided
1:5 Year	0.32	0.32	11	1.9	5.1
1:100 Year	0.32	0.32	14	4.5	

Roof Drain Storage Table for Area A-5		
Elevation	Area RD 1	Total Volume
m	m <sup>2</sup>	m <sup>3</sup>
0.00	0	0
0.05	10.7	0.3
0.10	42.7	1.6
0.15	95.8	5.1

1765 Montreal Road				
Novatech Project No. 121060				
REQUIRED STORAGE - 1:100 YEAR EVENT				
AREA A-5 Controlled Flow Roof Drain 13				
OTTAWA IDF CURVE				
Area =	0.010	ha	Qallow =	0.32 L/s
C =	1.00		Vol(max) =	4.5 m3
Time (min)	Intensity (mm/hr)	Q (L/s)	Qnet (L/s)	Vol (m3)
5	242.70	6.75	6.43	1.93
10	178.56	4.96	4.64	2.79
15	142.89	3.97	3.65	3.29
20	119.95	3.33	3.01	3.62
25	103.85	2.89	2.57	3.85
30	91.87	2.55	2.23	4.02
35	82.58	2.30	1.98	4.15
40	75.15	2.09	1.77	4.25
45	69.05	1.92	1.60	4.32
50	63.95	1.78	1.46	4.37
55	59.62	1.66	1.34	4.41
60	55.89	1.55	1.23	4.44
65	52.65	1.46	1.14	4.46
70	49.79	1.38	1.06	4.47
75	47.26	1.31	0.99	4.47
90	41.11	1.14	0.82	4.44
105	36.50	1.01	0.69	4.38
120	32.89	0.91	0.59	4.28

Stage Storage Curve: Area A-5  
Controlled Roof Drain 13

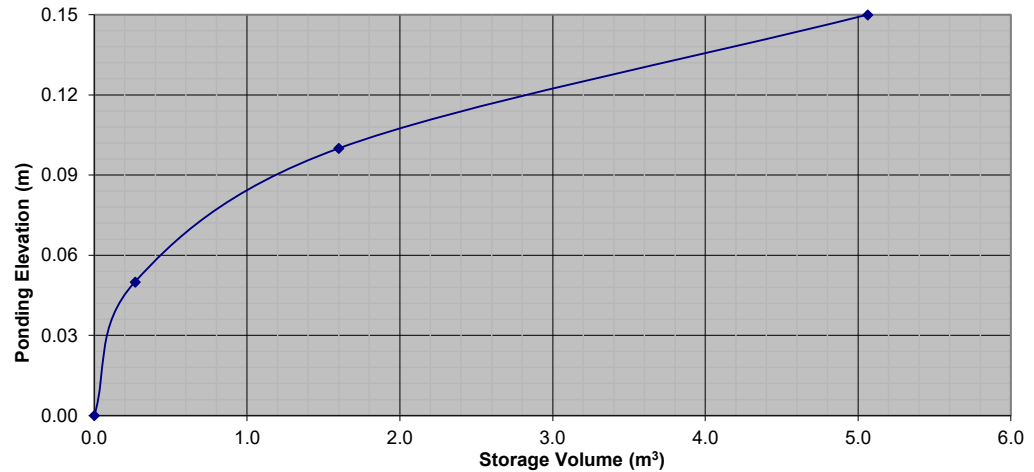

1765 Montreal Road				
Novatech Project No. 121060				
REQUIRED STORAGE - 1:5 YEAR EVENT				
AREA A-5 Controlled Flow Roof Drain 14				
OTTAWA IDF CURVE				
Area =	0.010	ha	Qallow =	0.79 L/s
C =	0.90		Vol(max) =	1.2 m3
Time (min)	Intensity (mm/hr)	Q (L/s)	Qnet (L/s)	Vol (m3)
5	141.18	3.53	2.74	0.82
10	104.19	2.61	1.82	1.09
15	83.56	2.09	1.30	1.17
20	70.25	1.76	0.97	1.16
25	60.90	1.52	0.73	1.10
30	53.93	1.35	0.56	1.01
35	48.52	1.21	0.42	0.89
40	44.18	1.11	0.32	0.76
45	40.63	1.02	0.23	0.61
50	37.65	0.94	0.15	0.46
55	35.12	0.88	0.09	0.29
60	32.94	0.82	0.03	0.12
65	31.04	0.78	-0.01	-0.05
70	29.37	0.73	-0.06	-0.23
75	27.89	0.70	-0.09	-0.42
90	24.29	0.61	-0.18	-0.98
105	21.58	0.54	-0.25	-1.58
120	19.47	0.49	-0.30	-2.18

(6x) WATTS Adjustable Accutrol Weir RD-100-A-ADJ: Weir Setting = 1/4 Exposed					
Design Event	Flow/Drain (L/s)	Total Flow (L/s)	Ponding (cm)	Storage (m <sup>3</sup> )	
				Required	Provided
1:5 Year	0.79	0.79	10	1.2	4.0
1:100 Year	0.87	0.87	13	3.0	

Roof Drain Storage Table for Area A-5		
Elevation	Area RD 1	Total Volume
m	m <sup>2</sup>	m <sup>3</sup>
0.00	0	0
0.05	8.5	0.2
0.10	33.7	1.3
0.15	76.1	4.0

Stage Storage Curve: Area A-5  
Controlled Roof Drain 14

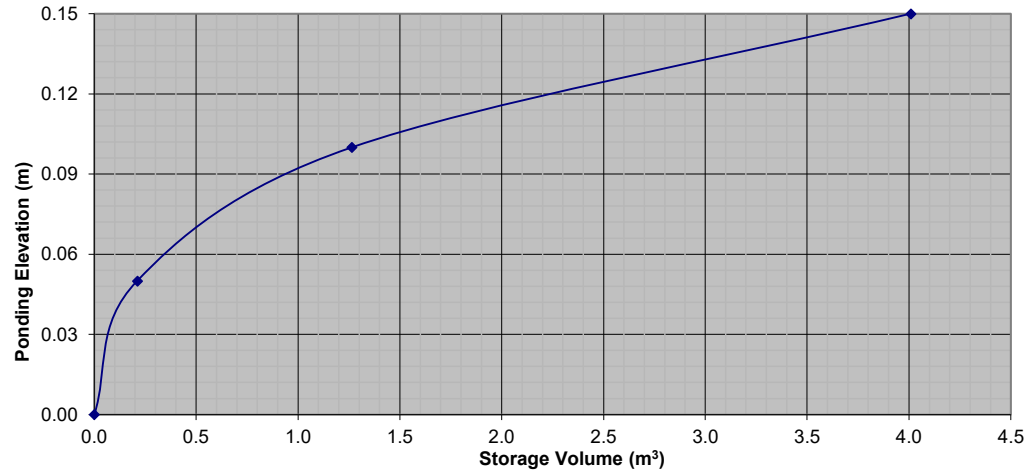

1765 Montreal Road				
Novatech Project No. 121060				
REQUIRED STORAGE - 1:100 YEAR EVENT				
AREA A-5 Controlled Flow Roof Drain 14				
OTTAWA IDF CURVE				
Area =	0.010	ha	Qallow =	0.87 L/s
C =	1.00		Vol(max) =	3.0 m3
Time (min)	Intensity (mm/hr)	Q (L/s)	Qnet (L/s)	Vol (m3)
5	242.70	6.75	5.88	1.76
10	178.56	4.96	4.09	2.46
15	142.89	3.97	3.10	2.79
20	119.95	3.33	2.46	2.96
25	103.85	2.89	2.02	3.03
30	91.87	2.55	1.68	3.03
35	82.58	2.30	1.43	2.99
40	75.15	2.09	1.22	2.93
45	69.05	1.92	1.05	2.83
50	63.95	1.78	0.91	2.72
55	59.62	1.66	0.79	2.60
60	55.89	1.55	0.68	2.46
65	52.65	1.46	0.59	2.31
70	49.79	1.38	0.51	2.16
75	47.26	1.31	0.44	2.00
90	41.11	1.14	0.27	1.47
105	36.50	1.01	0.14	0.91
120	32.89	0.91	0.04	0.32

1765 Montreal Road				
Novatech Project No. 121060				
REQUIRED STORAGE - 1:5 YEAR EVENT				
AREA A-5 Controlled Flow Roof Drain 15				
OTTAWA IDF CURVE				
Area =	0.008	ha	Qallow =	0.32 L/s
C =	0.90		Vol(max) =	1.4 m3
Time (min)	Intensity (mm/hr)	Q (L/s)	Qnet (L/s)	Vol (m3)
5	141.18	2.83	2.51	0.75
10	104.19	2.09	1.77	1.06
15	83.56	1.67	1.35	1.22
20	70.25	1.41	1.09	1.30
25	60.90	1.22	0.90	1.35
30	53.93	1.08	0.76	1.37
35	48.52	0.97	0.65	1.37
40	44.18	0.88	0.56	1.35
45	40.63	0.81	0.49	1.33
50	37.65	0.75	0.43	1.30
55	35.12	0.70	0.38	1.26
60	32.94	0.66	0.34	1.22
65	31.04	0.62	0.30	1.18
70	29.37	0.59	0.27	1.13
75	27.89	0.56	0.24	1.07
90	24.29	0.49	0.17	0.90
105	21.58	0.43	0.11	0.71
120	19.47	0.39	0.07	0.50

(6x) WATTS Adjustable Accutrol Weir RD-100-A-ADJ: Weir Setting = Closed					
Design Event	Flow/Drain (L/s)	Total Flow (L/s)	Ponding (cm)	Storage (m <sup>3</sup> )	
				Required	Provided
1:5 Year	0.32	0.32	11	1.4	4.0
1:100 Year	0.32	0.32	14	3.3	

Roof Drain Storage Table for Area A-5		
Elevation	Area RD 1	Total Volume
m	m <sup>2</sup>	m <sup>3</sup>
0.00	0	0
0.05	8.5	0.2
0.10	33.7	1.3
0.15	76.0	4.0

Stage Storage Curve: Area A-5  
Controlled Roof Drain 15

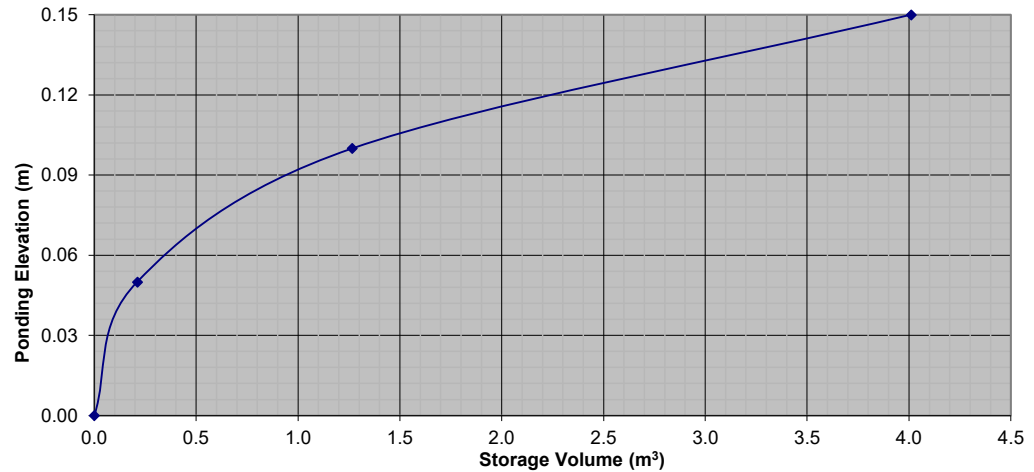

1765 Montreal Road				
Novatech Project No. 121060				
REQUIRED STORAGE - 1:100 YEAR EVENT				
AREA A-5 Controlled Flow Roof Drain 15				
OTTAWA IDF CURVE				
Area =	0.008	ha	Qallow =	0.32 L/s
C =	1.00		Vol(max) =	3.3 m3
Time (min)	Intensity (mm/hr)	Q (L/s)	Qnet (L/s)	Vol (m3)
5	242.70	5.40	5.08	1.52
10	178.56	3.97	3.65	2.19
15	142.89	3.18	2.86	2.57
20	119.95	2.67	2.35	2.82
25	103.85	2.31	1.99	2.98
30	91.87	2.04	1.72	3.10
35	82.58	1.84	1.52	3.18
40	75.15	1.67	1.35	3.24
45	69.05	1.54	1.22	3.28
50	63.95	1.42	1.10	3.31
55	59.62	1.33	1.01	3.32
60	55.89	1.24	0.92	3.32
65	52.65	1.17	0.85	3.32
70	49.79	1.11	0.79	3.31
75	47.26	1.05	0.73	3.29
90	41.11	0.91	0.59	3.21
105	36.50	0.81	0.49	3.10
120	32.89	0.73	0.41	2.96

1765 Montreal Road				
Novatech Project No. 121060				
REQUIRED STORAGE - 1:5 YEAR EVENT				
AREA A-5 Controlled Flow Roof Drain 16				
OTTAWA IDF CURVE				
Area =	0.010	ha	Qallow =	0.32 L/s
C =	0.90		Vol(max) =	1.9 m3
Time (min)	Intensity (mm/hr)	Q (L/s)	Qnet (L/s)	Vol (m3)
5	141.18	3.53	3.21	0.96
10	104.19	2.61	2.29	1.37
15	83.56	2.09	1.77	1.59
20	70.25	1.76	1.44	1.73
25	60.90	1.52	1.20	1.81
30	53.93	1.35	1.03	1.85
35	48.52	1.21	0.89	1.88
40	44.18	1.11	0.79	1.89
45	40.63	1.02	0.70	1.88
50	37.65	0.94	0.62	1.87
55	35.12	0.88	0.56	1.84
60	32.94	0.82	0.50	1.82
65	31.04	0.78	0.46	1.78
70	29.37	0.73	0.41	1.74
75	27.89	0.70	0.38	1.70
90	24.29	0.61	0.29	1.55
105	21.58	0.54	0.22	1.39
120	19.47	0.49	0.17	1.20

(6x) WATTS Adjustable Accutrol Weir RD-100-A-ADJ: Weir Setting = Closed					
Design Event	Flow/Drain (L/s)	Total Flow (L/s)	Ponding (cm)	Storage (m <sup>3</sup> )	
				Required	Provided
1:5 Year	0.32	0.32	11	1.9	5.1
1:100 Year	0.32	0.32	14	4.5	

Roof Drain Storage Table for Area A-5		
Elevation	Area RD 1	Total Volume
m	m <sup>2</sup>	m <sup>3</sup>
0.00	0	0
0.05	10.7	0.3
0.10	42.9	1.6
0.15	96.5	5.1

1765 Montreal Road				
Novatech Project No. 121060				
REQUIRED STORAGE - 1:100 YEAR EVENT				
AREA A-5 Controlled Flow Roof Drain 16				
OTTAWA IDF CURVE				
Area =	0.010	ha	Qallow =	0.32 L/s
C =	1.00		Vol(max) =	4.5 m3
Time (min)	Intensity (mm/hr)	Q (L/s)	Qnet (L/s)	Vol (m3)
5	242.70	6.75	6.43	1.93
10	178.56	4.96	4.64	2.79
15	142.89	3.97	3.65	3.29
20	119.95	3.33	3.01	3.62
25	103.85	2.89	2.57	3.85
30	91.87	2.55	2.23	4.02
35	82.58	2.30	1.98	4.15
40	75.15	2.09	1.77	4.25
45	69.05	1.92	1.60	4.32
50	63.95	1.78	1.46	4.37
55	59.62	1.66	1.34	4.41
60	55.89	1.55	1.23	4.44
65	52.65	1.46	1.14	4.46
70	49.79	1.38	1.06	4.47
75	47.26	1.31	0.99	4.47
90	41.11	1.14	0.82	4.44
105	36.50	1.01	0.69	4.38
120	32.89	0.91	0.59	4.28

Stage Storage Curve: Area A-5  
Controlled Roof Drain 16

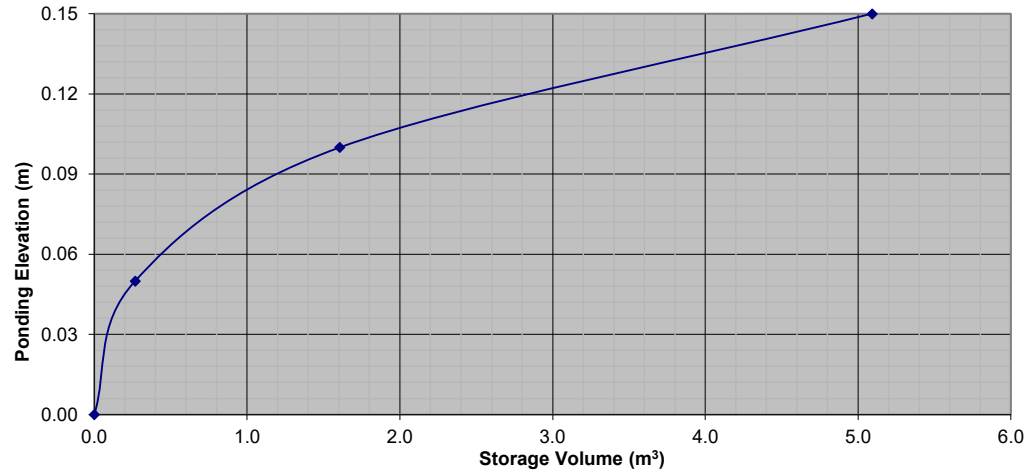

1765 Montreal Road				
Novatech Project No. 121060				
REQUIRED STORAGE - 1:5 YEAR EVENT				
AREA A-5 Controlled Flow Roof Drain 17				
OTTAWA IDF CURVE				
Area =	0.010	ha	Qallow =	0.32 L/s
C =	0.90		Vol(max) =	1.9 m3
Time (min)	Intensity (mm/hr)	Q (L/s)	Qnet (L/s)	Vol (m3)
5	141.18	3.53	3.21	0.96
10	104.19	2.61	2.29	1.37
15	83.56	2.09	1.77	1.59
20	70.25	1.76	1.44	1.73
25	60.90	1.52	1.20	1.81
30	53.93	1.35	1.03	1.85
35	48.52	1.21	0.89	1.88
40	44.18	1.11	0.79	1.89
45	40.63	1.02	0.70	1.88
50	37.65	0.94	0.62	1.87
55	35.12	0.88	0.56	1.84
60	32.94	0.82	0.50	1.82
65	31.04	0.78	0.46	1.78
70	29.37	0.73	0.41	1.74
75	27.89	0.70	0.38	1.70
90	24.29	0.61	0.29	1.55
105	21.58	0.54	0.22	1.39
120	19.47	0.49	0.17	1.20

(6x) WATTS Adjustable Accutrol Weir RD-100-A-ADJ: Weir Setting = Closed					
Design Event	Flow/Drain (L/s)	Total Flow (L/s)	Ponding (cm)	Storage (m <sup>3</sup> )	
				Required	Provided
1:5 Year	0.32	0.32	11	1.9	5.1
1:100 Year	0.32	0.32	14	4.5	

Roof Drain Storage Table for Area A-5		
Elevation	Area RD 1	Total Volume
m	m <sup>2</sup>	m <sup>3</sup>
0.00	0	0
0.05	10.7	0.3
0.10	42.9	1.6
0.15	96.6	5.1

1765 Montreal Road				
Novatech Project No. 121060				
REQUIRED STORAGE - 1:100 YEAR EVENT				
AREA A-5 Controlled Flow Roof Drain 17				
OTTAWA IDF CURVE				
Area =	0.010	ha	Qallow =	0.32 L/s
C =	1.00		Vol(max) =	4.5 m3
Time (min)	Intensity (mm/hr)	Q (L/s)	Qnet (L/s)	Vol (m3)
5	242.70	6.75	6.43	1.93
10	178.56	4.96	4.64	2.79
15	142.89	3.97	3.65	3.29
20	119.95	3.33	3.01	3.62
25	103.85	2.89	2.57	3.85
30	91.87	2.55	2.23	4.02
35	82.58	2.30	1.98	4.15
40	75.15	2.09	1.77	4.25
45	69.05	1.92	1.60	4.32
50	63.95	1.78	1.46	4.37
55	59.62	1.66	1.34	4.41
60	55.89	1.55	1.23	4.44
65	52.65	1.46	1.14	4.46
70	49.79	1.38	1.06	4.47
75	47.26	1.31	0.99	4.47
90	41.11	1.14	0.82	4.44
105	36.50	1.01	0.69	4.38
120	32.89	0.91	0.59	4.28

Stage Storage Curve: Area A-5  
Controlled Roof Drain 17

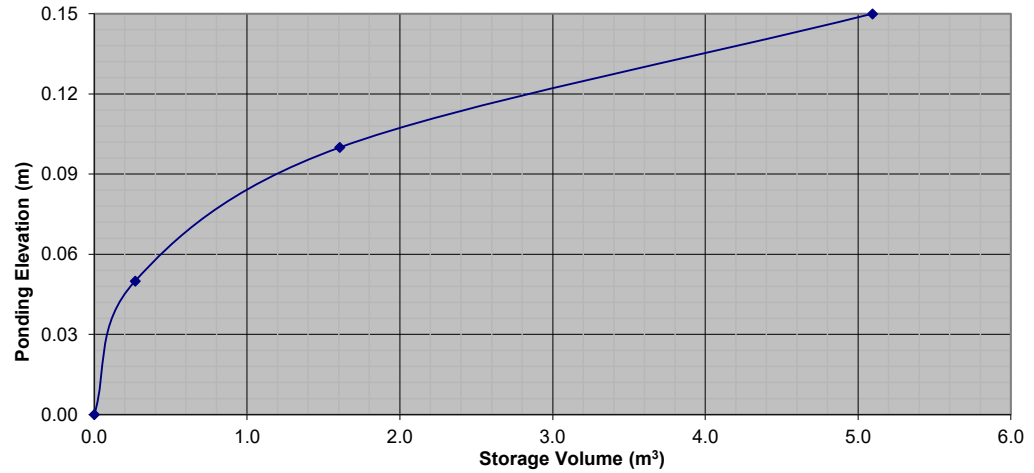

1765 Montreal Road				
Novatech Project No. 121060				
REQUIRED STORAGE - 1:5 YEAR EVENT				
AREA A-5 Controlled Flow Roof Drain 18				
OTTAWA IDF CURVE				
Area =	0.013	ha	Qallow =	0.79 L/s
C =	0.90		Vol(max) =	1.8 m3
Time (min)	Intensity (mm/hr)	Q (L/s)	Qnet (L/s)	Vol (m3)
5	141.18	4.59	3.80	1.14
10	104.19	3.39	2.60	1.56
15	83.56	2.72	1.93	1.74
20	70.25	2.28	1.49	1.79
25	60.90	1.98	1.19	1.79
30	53.93	1.75	0.96	1.74
35	48.52	1.58	0.79	1.65
40	44.18	1.44	0.65	1.55
45	40.63	1.32	0.53	1.44
50	37.65	1.22	0.43	1.30
55	35.12	1.14	0.35	1.16
60	32.94	1.07	0.28	1.01
65	31.04	1.01	0.22	0.86
70	29.37	0.96	0.17	0.69
75	27.89	0.91	0.12	0.53
90	24.29	0.79	0.00	0.00
105	21.58	0.70	-0.09	-0.55
120	19.47	0.63	-0.16	-1.13

(6x) WATTS Adjustable Accutrol Weir RD-100-A-ADJ: Weir Setting = 1/4 Exposed					
Design Event	Flow/Drain (L/s)	Total Flow (L/s)	Ponding (cm)	Storage (m <sup>3</sup> )	
				Required	Provided
1:5 Year	0.79	0.79	10	1.8	6.7
1:100 Year	0.87	0.87	13	4.4	

Roof Drain Storage Table for Area A-5		
Elevation	Area RD 1	Total Volume
m	m <sup>2</sup>	m <sup>3</sup>
0.00	0	0
0.05	14.1	0.4
0.10	56.6	2.1
0.15	127.3	6.7

Stage Storage Curve: Area A-5  
Controlled Roof Drain 18

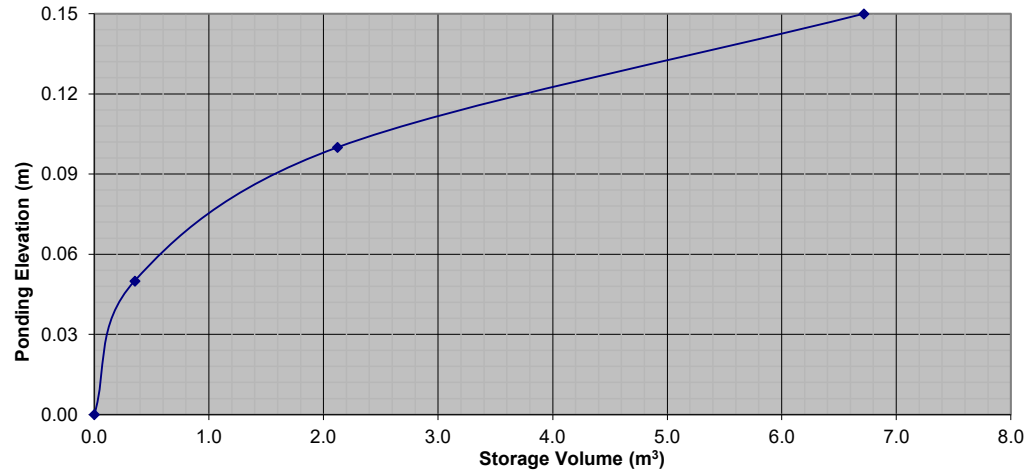

1765 Montreal Road				
Novatech Project No. 121060				
REQUIRED STORAGE - 1:100 YEAR EVENT				
AREA A-5 Controlled Flow Roof Drain 18				
OTTAWA IDF CURVE				
Area =	0.013	ha	Qallow =	0.87 L/s
C =	1.00		Vol(max) =	4.4 m3
Time (min)	Intensity (mm/hr)	Q (L/s)	Qnet (L/s)	Vol (m3)
5	242.70	8.77	7.90	2.37
10	178.56	6.45	5.58	3.35
15	142.89	5.16	4.29	3.86
20	119.95	4.34	3.47	4.16
25	103.85	3.75	2.88	4.32
30	91.87	3.32	2.45	4.41
35	82.58	2.98	2.11	4.44
40	75.15	2.72	1.85	4.43
45	69.05	2.50	1.63	4.39
50	63.95	2.31	1.44	4.32
55	59.62	2.15	1.28	4.24
60	55.89	2.02	1.15	4.14
65	52.65	1.90	1.03	4.03
70	49.79	1.80	0.93	3.90
75	47.26	1.71	0.84	3.77
90	41.11	1.49	0.62	3.33
105	36.50	1.32	0.45	2.83
120	32.89	1.19	0.32	2.30



1765 Montreal Road				
Novatech Project No. 121060				
REQUIRED STORAGE - 1:5 YEAR EVENT				
AREA A-5 Controlled Flow Roof Drain 19				
OTTAWA IDF CURVE				
Area =	0.012	ha	Qallow =	0.75 L/s
C =	0.90		Vol(max) =	1.6 m3
Time (min)	Intensity (mm/hr)	Q (L/s)	Qnet (L/s)	Vol (m3)
5	141.18	4.24	3.49	1.05
10	104.19	3.13	2.38	1.43
15	83.56	2.51	1.76	1.58
20	70.25	2.11	1.36	1.63
25	60.90	1.83	1.08	1.62
30	53.93	1.62	0.87	1.56
35	48.52	1.46	0.71	1.48
40	44.18	1.33	0.58	1.38
45	40.63	1.22	0.47	1.27
50	37.65	1.13	0.38	1.14
55	35.12	1.05	0.30	1.00
60	32.94	0.99	0.24	0.86
65	31.04	0.93	0.18	0.71
70	29.37	0.88	0.13	0.55
75	27.89	0.84	0.09	0.39
90	24.29	0.73	-0.02	-0.11
105	21.58	0.65	-0.10	-0.64
120	19.47	0.58	-0.17	-1.19

(6x) WATTS Adjustable Accutrol Weir RD-100-A-ADJ: Weir Setting = 1/4 Exposed					
Design Event	Flow/Drain (L/s)	Total Flow (L/s)	Ponding (cm)	Storage (m <sup>3</sup> )	
				Required	Provided
1:5 Year	0.75	0.75	9	1.6	6.4
1:100 Year	0.87	0.87	13	4.0	

Roof Drain Storage Table for Area A-5		
Elevation	Area RD 1	Total Volume
m	m <sup>2</sup>	m <sup>3</sup>
0.00	0	0
0.05	13.5	0.3
0.10	54.1	2.0
0.15	120.4	6.4

1765 Montreal Road				
Novatech Project No. 121060				
REQUIRED STORAGE - 1:100 YEAR EVENT				
AREA A-5 Controlled Flow Roof Drain 19				
OTTAWA IDF CURVE				
Area =	0.012	ha	Qallow =	0.87 L/s
C =	1.00		Vol(max) =	4.0 m3
Time (min)	Intensity (mm/hr)	Q (L/s)	Qnet (L/s)	Vol (m3)
5	242.70	8.10	7.23	2.17
10	178.56	5.96	5.09	3.05
15	142.89	4.77	3.90	3.51
20	119.95	4.00	3.13	3.76
25	103.85	3.46	2.59	3.89
30	91.87	3.06	2.19	3.95
35	82.58	2.75	1.88	3.96
40	75.15	2.51	1.64	3.93
45	69.05	2.30	1.43	3.87
50	63.95	2.13	1.26	3.79
55	59.62	1.99	1.12	3.69
60	55.89	1.86	0.99	3.58
65	52.65	1.76	0.89	3.46
70	49.79	1.66	0.79	3.32
75	47.26	1.58	0.71	3.18
90	41.11	1.37	0.50	2.71
105	36.50	1.22	0.35	2.19
120	32.89	1.10	0.23	1.64

Stage Storage Curve: Area A-5  
Controlled Roof Drain 19

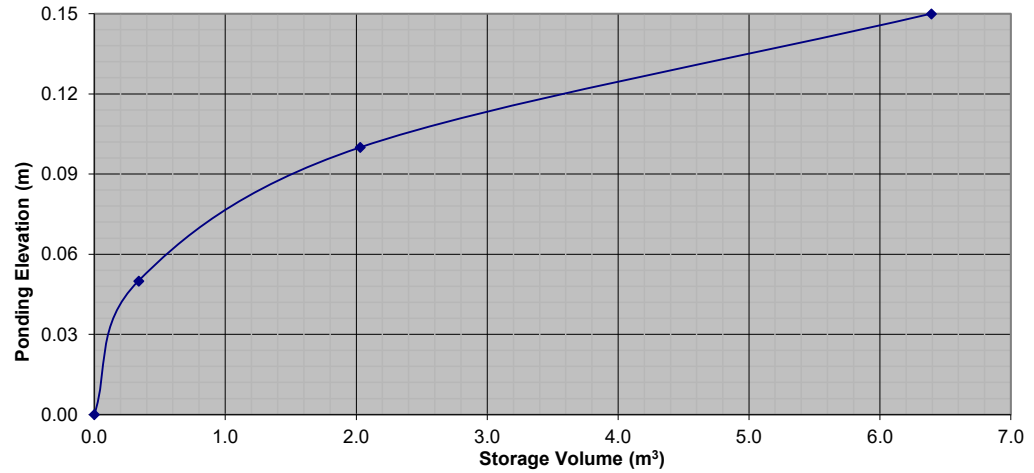

1765 Montreal Road				
Novatech Project No. 121060				
REQUIRED STORAGE - 1:5 YEAR EVENT				
AREA A-5 Controlled Flow Roof Drain 20				
OTTAWA IDF CURVE				
Area =	0.015	ha	Qallow =	0.79 L/s
C =	0.90		Vol(max) =	2.2 m3
Time (min)	Intensity (mm/hr)	Q (L/s)	Qnet (L/s)	Vol (m3)
5	141.18	5.30	4.51	1.35
10	104.19	3.91	3.12	1.87
15	83.56	3.14	2.35	2.11
20	70.25	2.64	1.85	2.22
25	60.90	2.29	1.50	2.24
30	53.93	2.02	1.23	2.22
35	48.52	1.82	1.03	2.16
40	44.18	1.66	0.87	2.08
45	40.63	1.52	0.73	1.98
50	37.65	1.41	0.62	1.87
55	35.12	1.32	0.53	1.74
60	32.94	1.24	0.45	1.61
65	31.04	1.17	0.38	1.46
70	29.37	1.10	0.31	1.31
75	27.89	1.05	0.26	1.15
90	24.29	0.91	0.12	0.66
105	21.58	0.81	0.02	0.13
120	19.47	0.73	-0.06	-0.43

(6x) WATTS Adjustable Accutrol Weir RD-100-A-ADJ: Weir Setting = 1/4 Exposed					
Design Event	Flow/Drain (L/s)	Total Flow (L/s)	Ponding (cm)	Storage (m <sup>3</sup> )	
				Required	Provided
1:5 Year	0.79	0.79	10	2.2	7.5
1:100 Year	0.87	0.87	13	5.4	

Roof Drain Storage Table for Area A-5		
Elevation	Area RD 1	Total Volume
m	m <sup>2</sup>	m <sup>3</sup>
0.00	0	0
0.05	15.7	0.4
0.10	62.8	2.4
0.15	141.9	7.5

Stage Storage Curve: Area A-5  
Controlled Roof Drain 20

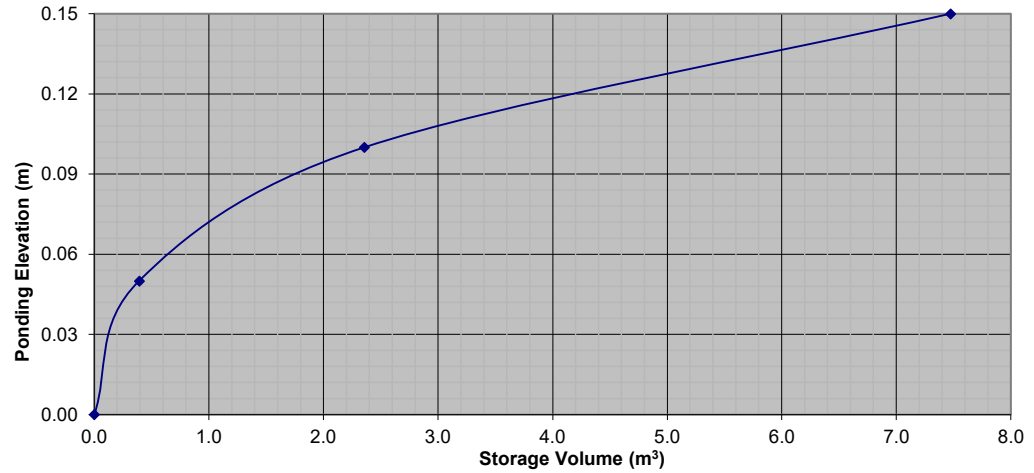

1765 Montreal Road				
Novatech Project No. 121060				
REQUIRED STORAGE - 1:100 YEAR EVENT				
AREA A-5 Controlled Flow Roof Drain 20				
OTTAWA IDF CURVE				
Area =	0.015	ha	Qallow =	0.87 L/s
C =	1.00		Vol(max) =	5.4 m3
Time (min)	Intensity (mm/hr)	Q (L/s)	Qnet (L/s)	Vol (m3)
5	242.70	10.12	9.25	2.78
10	178.56	7.45	6.58	3.95
15	142.89	5.96	5.09	4.58
20	119.95	5.00	4.13	4.96
25	103.85	4.33	3.46	5.19
30	91.87	3.83	2.96	5.33
35	82.58	3.44	2.57	5.40
40	75.15	3.13	2.26	5.43
45	69.05	2.88	2.01	5.43
50	63.95	2.67	1.80	5.39
55	59.62	2.49	1.62	5.33
60	55.89	2.33	1.46	5.26
65	52.65	2.20	1.33	5.17
70	49.79	2.08	1.21	5.07
75	47.26	1.97	1.10	4.95
90	41.11	1.71	0.84	4.56
105	36.50	1.52	0.65	4.11
120	32.89	1.37	0.50	3.61

1765 Montreal Road				
Novatech Project No. 121060				
REQUIRED STORAGE - 1:5 YEAR EVENT				
AREA A-5 Controlled Flow Roof Drain 21				
OTTAWA IDF CURVE				
Area =	0.014	ha	Qallow =	0.79 L/s
C =	0.90		Vol(max) =	2.0 m3
Time (min)	Intensity (mm/hr)	Q (L/s)	Qnet (L/s)	Vol (m3)
5	141.18	4.95	4.16	1.25
10	104.19	3.65	2.86	1.72
15	83.56	2.93	2.14	1.92
20	70.25	2.46	1.67	2.00
25	60.90	2.13	1.34	2.01
30	53.93	1.89	1.10	1.98
35	48.52	1.70	0.91	1.91
40	44.18	1.55	0.76	1.82
45	40.63	1.42	0.63	1.71
50	37.65	1.32	0.53	1.59
55	35.12	1.23	0.44	1.45
60	32.94	1.15	0.36	1.31
65	31.04	1.09	0.30	1.16
70	29.37	1.03	0.24	1.00
75	27.89	0.98	0.19	0.84
90	24.29	0.85	0.06	0.33
105	21.58	0.76	-0.03	-0.21
120	19.47	0.68	-0.11	-0.78

(6x) WATTS Adjustable Accutrol Weir RD-100-A-ADJ: Weir Setting = 1/4 Exposed					
Design Event	Flow/Drain (L/s)	Total Flow (L/s)	Ponding (cm)	Storage (m <sup>3</sup> )	
				Required	Provided
1:5 Year	0.79	0.79	10	2.0	6.0
1:100 Year	0.91	0.91	14	4.8	

Roof Drain Storage Table for Area A-5		
Elevation	Area RD 1	Total Volume
m	m <sup>2</sup>	m <sup>3</sup>
0.00	0	0
0.05	12.9	0.3
0.10	51.5	1.9
0.15	113.0	6.0

1765 Montreal Road				
Novatech Project No. 121060				
REQUIRED STORAGE - 1:100 YEAR EVENT				
AREA A-5 Controlled Flow Roof Drain 21				
OTTAWA IDF CURVE				
Area =	0.014	ha	Qallow =	0.91 L/s
C =	1.00		Vol(max) =	4.8 m3
Time (min)	Intensity (mm/hr)	Q (L/s)	Qnet (L/s)	Vol (m3)
5	242.70	9.45	8.54	2.56
10	178.56	6.95	6.04	3.62
15	142.89	5.56	4.65	4.19
20	119.95	4.67	3.76	4.51
25	103.85	4.04	3.13	4.70
30	91.87	3.58	2.67	4.80
35	82.58	3.21	2.30	4.84
40	75.15	2.92	2.01	4.84
45	69.05	2.69	1.78	4.80
50	63.95	2.49	1.58	4.74
55	59.62	2.32	1.41	4.65
60	55.89	2.18	1.27	4.56
65	52.65	2.05	1.14	4.44
70	49.79	1.94	1.03	4.32
75	47.26	1.84	0.93	4.18
90	41.11	1.60	0.69	3.73
105	36.50	1.42	0.51	3.22
120	32.89	1.28	0.37	2.67

Stage Storage Curve: Area A-5  
Controlled Roof Drain 21

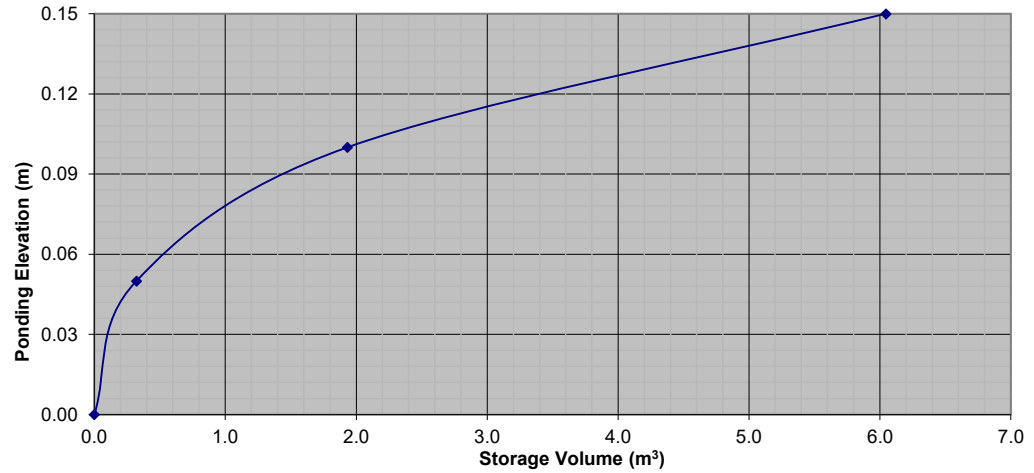

1765 Montreal Road				
Novatech Project No. 121060				
REQUIRED STORAGE - 1:5 YEAR EVENT				
AREA A-5 Controlled Flow Roof Drain 22				
OTTAWA IDF CURVE				
Area =	0.014	ha	Qallow =	0.79 L/s
C =	0.90		Vol(max) =	2.0 m3
Time (min)	Intensity (mm/hr)	Q (L/s)	Qnet (L/s)	Vol (m3)
5	141.18	4.95	4.16	1.25
10	104.19	3.65	2.86	1.72
15	83.56	2.93	2.14	1.92
20	70.25	2.46	1.67	2.00
25	60.90	2.13	1.34	2.01
30	53.93	1.89	1.10	1.98
35	48.52	1.70	0.91	1.91
40	44.18	1.55	0.76	1.82
45	40.63	1.42	0.63	1.71
50	37.65	1.32	0.53	1.59
55	35.12	1.23	0.44	1.45
60	32.94	1.15	0.36	1.31
65	31.04	1.09	0.30	1.16
70	29.37	1.03	0.24	1.00
75	27.89	0.98	0.19	0.84
90	24.29	0.85	0.06	0.33
105	21.58	0.76	-0.03	-0.21
120	19.47	0.68	-0.11	-0.78

(6x) WATTS Adjustable Accutrol Weir RD-100-A-ADJ: Weir Setting = 1/4 Exposed					
Design Event	Flow/Drain (L/s)	Total Flow (L/s)	Ponding (cm)	Storage (m <sup>3</sup> )	
				Required	Provided
1:5 Year	0.79	0.79	10	2.0	6.8
1:100 Year	0.87	0.87	13	4.9	

Roof Drain Storage Table for Area A-5		
Elevation	Area RD 1	Total Volume
m	m <sup>2</sup>	m <sup>3</sup>
0.00	0	0
0.05	14.4	0.4
0.10	57.4	2.2
0.15	128.6	6.8

1765 Montreal Road				
Novatech Project No. 121060				
REQUIRED STORAGE - 1:100 YEAR EVENT				
AREA A-5 Controlled Flow Roof Drain 22				
OTTAWA IDF CURVE				
Area =	0.014	ha	Qallow =	0.87 L/s
C =	1.00		Vol(max) =	4.9 m3
Time (min)	Intensity (mm/hr)	Q (L/s)	Qnet (L/s)	Vol (m3)
5	242.70	9.45	8.58	2.57
10	178.56	6.95	6.08	3.65
15	142.89	5.56	4.69	4.22
20	119.95	4.67	3.80	4.56
25	103.85	4.04	3.17	4.76
30	91.87	3.58	2.71	4.87
35	82.58	3.21	2.34	4.92
40	75.15	2.92	2.05	4.93
45	69.05	2.69	1.82	4.91
50	63.95	2.49	1.62	4.86
55	59.62	2.32	1.45	4.79
60	55.89	2.18	1.31	4.70
65	52.65	2.05	1.18	4.60
70	49.79	1.94	1.07	4.48
75	47.26	1.84	0.97	4.36
90	41.11	1.60	0.73	3.94
105	36.50	1.42	0.55	3.47
120	32.89	1.28	0.41	2.95

Stage Storage Curve: Area A-5  
Controlled Roof Drain 22

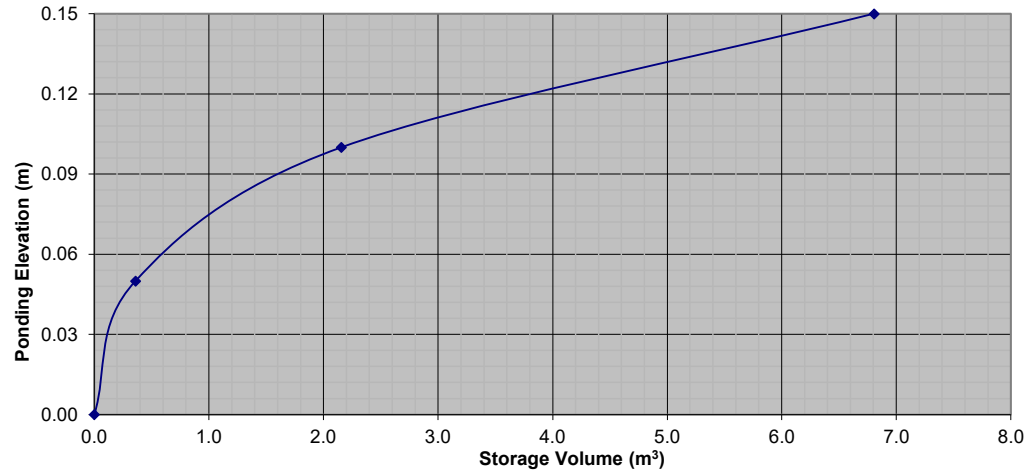

1765 Montreal Road				
Novatech Project No. 121060				
REQUIRED STORAGE - 1:2 YEAR EVENT				
AREA A-2 Controlled Flow-Internal SWM Tank				
OTTAWA IDF CURVE				
Area =	0.282	ha	Qallow =	15.1 L/s
C =	0.80		Vol(max) =	21.4 m3
Time (min)	Intensity (mm/hr)	Q (L/s)	Qnet (L/s)	Vol (m3)
5	103.57	65.22	50.08	15.02
10	76.81	48.36	33.22	19.93
15	61.77	38.89	23.75	21.38
20	52.03	32.76	17.62	21.15
25	45.17	28.44	13.30	19.95
30	40.04	25.21	10.07	18.13
35	36.06	22.71	7.57	15.89
40	32.86	20.69	5.55	13.33
45	30.24	19.04	3.90	10.53
50	28.04	17.66	2.52	7.55
55	26.17	16.48	1.34	4.42
60	24.56	15.46	0.32	1.16
65	23.15	14.58	-0.56	-2.19
70	21.91	13.80	-1.34	-5.64
75	20.81	13.11	-2.03	-9.16
90	18.14	11.42	-3.72	-20.07
105	16.13	10.16	-4.98	-31.38
120	14.56	9.17	-5.97	-42.99
135	13.30	8.37	-6.77	-54.82
150	12.25	7.71	-7.43	-66.83

1765 Montreal Road				
Novatech Project No. 121060				
REQUIRED STORAGE - 1:5 YEAR EVENT				
AREA R-2 Controlled Flow-Internal SWM Tank				
OTTAWA IDF CURVE				
Area =	0.282	ha	Qallow =	15.1 L/s
C =	0.80		Vol(max) =	34.9 m3
Time (min)	Intensity (mm/hr)	Q (L/s)	Qnet (L/s)	Vol (m3)
5	141.18	88.90	73.76	22.13
10	104.19	65.61	50.47	30.28
15	83.56	52.61	37.47	33.73
20	70.25	44.24	29.10	34.91
25	60.90	38.34	23.20	34.81
30	53.93	33.96	18.82	33.87
35	48.52	30.55	15.41	32.36
40	44.18	27.82	12.68	30.44
45	40.63	25.58	10.44	28.20
50	37.65	23.71	8.57	25.71
55	35.12	22.12	6.98	23.02
60	32.94	20.74	5.60	20.17
65	31.04	19.55	4.41	17.19
70	29.37	18.49	3.35	14.09
75	27.89	17.56	2.42	10.89
90	24.29	15.29	0.15	0.83
105	21.58	13.59	-1.55	-9.77
120	19.47	12.26	-2.88	-20.75
135	17.76	11.19	-3.95	-32.03
150	16.36	10.30	-4.84	-43.54

1765 Montreal Road				
Novatech Project No. 121060				
REQUIRED STORAGE - 1:100 YEAR EVENT				
AREA A-2 Controlled Flow-Internal SWM Tank				
OTTAWA IDF CURVE				
Area =	0.282	ha	Qallow =	15.1 L/s
C =	0.90		Vol(max) =	90.4 m3
Time (min)	Intensity (mm/hr)	Q (L/s)	Qnet (L/s)	Vol (m3)
5	242.70	170.53	155.39	46.62
10	178.56	125.46	110.32	66.19
15	142.89	100.40	85.26	76.74
20	119.95	84.28	69.14	82.97
25	103.85	72.97	57.83	86.74
30	91.87	64.55	49.41	88.94
35	82.58	58.02	42.88	90.06
40	75.15	52.80	37.66	90.39
45	69.05	48.52	33.38	90.12
50	63.95	44.94	29.80	89.39
55	59.62	41.89	26.75	88.29
60	55.89	39.27	24.13	86.88
65	52.65	36.99	21.85	85.22
70	49.79	34.98	19.84	83.35
75	47.26	33.20	18.06	81.29
90	41.11	28.89	13.75	74.23
105	36.50	25.64	10.50	66.18
120	32.89	23.11	7.97	57.41
135	30.00	21.08	5.94	48.09
150	27.61	19.40	4.26	38.34

1765 Montreal Road				
Novatech Project No. 121060				
REQUIRED STORAGE - 1:100 YR + 20% IDF Increase				
AREA A-2 Controlled Flow-Internal SWM Tank				
OTTAWA IDF CURVE				
Area =	0.282	ha	Qallow =	15.1 L/s
C =	0.90		Vol(max) =	116.4 m3
Time (min)	Intensity (mm/hr)	Q (L/s)	Qnet (L/s)	Vol (m3)
5	291.24	204.64	189.50	56.85
10	214.27	150.56	135.42	81.25
15	171.47	120.48	105.34	94.81
20	143.94	101.14	86.00	103.20
25	124.62	87.56	72.42	108.63
30	110.24	77.46	62.32	112.18
35	99.09	69.63	54.49	114.43
40	90.17	63.36	48.22	115.73
45	82.86	58.22	43.08	116.32
50	76.74	53.92	38.78	116.35
55	71.55	50.27	35.13	115.94
60	67.07	47.13	31.99	115.16
65	63.18	44.39	29.25	114.08
70	59.75	41.98	26.84	112.73
75	56.71	39.84	24.70	111.17
90	49.33	34.66	19.52	105.43
105	43.80	30.77	15.63	98.49
120	39.47	27.74	12.60	90.69
135	36.00	25.29	10.15	82.24
150	33.13	23.28	8.14	73.27

## **APPENDIX F**

### **Control Flow Rood Drain Information**



**Adjustable Accutrol Weir**  
 Tag: RD-100-A-ADJ

**Adjustable Flow Control  
 for Roof Drains**

**ADJUSTABLE ACCUTROL (for Large Sump Roof Drains only)**

For more flexibility in controlling flow with heads deeper than 2", Watts Drainage offers the Adjustable Accutrol. The Adjustable Accutrol Weir is designed with a single parabolic opening that can be covered to restrict flow above 2" of head to less than 5 gpm per inch, up to 6" of head. To adjust the flow rate for depths over 2" of head, set the slot in the adjustable upper cone according to the flow rate required. Refer to Table 1 below.  
 Note: Flow rates are directly proportional to the amount of weir opening that is exposed.

**EXAMPLE:**

For example, if the adjustable upper cone is set to cover 1/2 of the weir opening, flow rates above 2" of head will be restricted to 2-1/2 gpm per inch of head.

Therefore, at 3" of head, the flow rate through the Accutrol Weir that has 1/2 the slot exposed will be:  
 [5 gpm (per inch of head) x 2 inches of head] + 2-1/2 gpm (for the third inch of head) = 12-1/2 gpm.

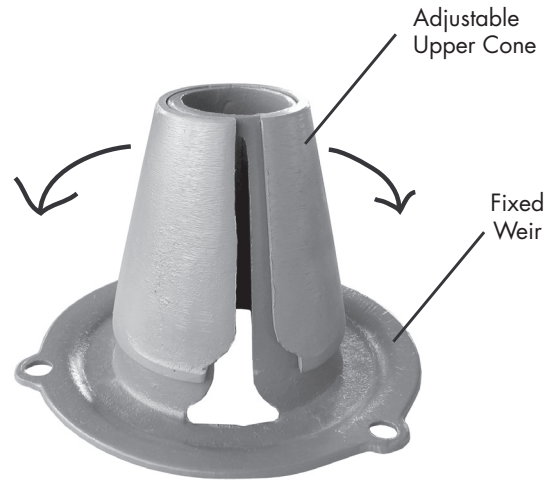
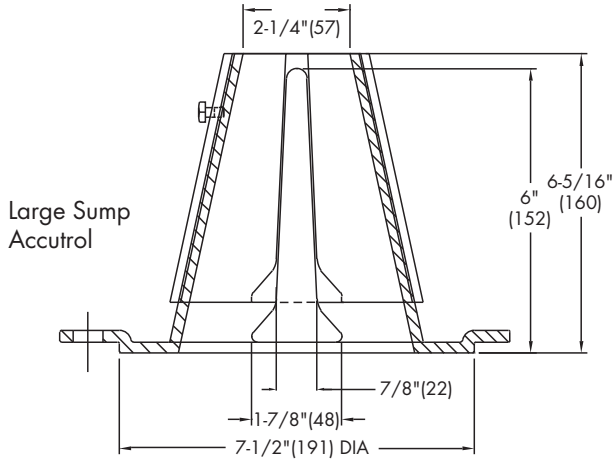

1/2 Weir Opening Exposed Shown Above

TABLE 1. Adjustable Accutrol Flow Rate Settings

Weir Opening Exposed	1"	2"	3"	4"	5"	6"
	Flow Rate (gallons per minute)					
Fully Exposed	5	10	15	20	25	30
3/4	5	10	13.75	17.5	21.25	25
1/2	5	10	12.5	15	17.5	20
1/4	5	10	11.25	12.5	13.75	15
Closed	5	5	5	5	5	5

Job Name \_\_\_\_\_  
 Job Location \_\_\_\_\_  
 Engineer \_\_\_\_\_

Contractor \_\_\_\_\_  
 Contractor's P.O. No. \_\_\_\_\_  
 Representative \_\_\_\_\_

Watts product specifications in U.S. customary units and metric are approximate and are provided for reference only. For precise measurements, please contact Watts Technical Service. Watts reserves the right to change or modify product design, construction, specifications, or materials without prior notice and without incurring any obligation to make such changes and modifications on Watts products previously or subsequently sold.

**USA:** Tel: (800) 338-2581 • Fax: (828) 248-3929 • Watts.com  
**Canada:** Tel: (905) 332-4090 • Fax: (905) 332-7068 • Watts.ca  
**Latin America:** Tel: (52) 81-1001-8600 • Fax: (52) 81-8000-7091 • Watts.com



A Watts Water Technologies Company

**APPENDIX G**  
**CDS Unit Information**



## Miro Savic

---

**From:** Patrick <patrick@echelonenvironmental.ca>  
**Sent:** Monday, December 12, 2022 3:35 PM  
**To:** Miro Savic  
**Cc:** Larry Colbran  
**Subject:** RE: 1765 Montreal Road - CDS Sizing Request  
**Attachments:** CDS TSSR - 1765 Montreal Road - PMSU 2015\_4 .pdf

Good afternoon Miro,

Thank you for reaching out for another CDS design! For this site I recommend a CDS PMSU 2015\_4 which has a treatment flow rate of 20 L/s and a budget price of \$18,500.

- % of net annual TSS removal – See sizing report
- % of net annual treatment volume for the tributary area – see sizing report
- The treatment capacity in L/s – 20 L/s
- The sediment storage capacity in m<sup>3</sup> – 0.838m<sup>3</sup>
- The oil storage capacity in L - 232 L
- The total unit storage capacity in L – 1.590m<sup>3</sup>

Best regards,

Patrick Graham  
Project Manager



**\*\*\*Please note our new addresses\*\*\***

Echelon Environmental Inc.  
55 Albert Street  
Suite 200  
Markham, ON  
L3P 2T4  
Phone: 1-905-948-0000  
Cell: 416-460-5819  
Fax: 1-905-948-0577  
email [patrick@echelonenvironmental.ca](mailto:patrick@echelonenvironmental.ca)

**Mailing Address:**

Echelon Environmental Inc.  
5694 Hwy #7 East  
Suite 354  
Markham, ON  
L3P 0E3

---

**From:** Miro Savic <m.savic@novatech-eng.com>  
**Sent:** Monday, December 12, 2022 2:01 PM  
**To:** Patrick <patrick@echelonenvironmental.ca>  
**Cc:** Larry Colbran <l.colbran@novatech-eng.com>  
**Subject:** 1765 Montreal Road - CDS Sizing Request

Hello Patrick,

We are currently working on a project that requires a stormwater quality control unit to treat water from the paved parking lot, the building roof and landscaped areas. The project proposes to develop a high-rise residential building and is located at 1765 Montreal Road in the City of Ottawa.

The project details are as follows:

Tributary area = **0.398 ha**

Imperviousness = **90% or Cw = 0.83**

Time of concentration = 10min

IDF Curve = City of Ottawa (104.2mm/hr Intensity for 5yr) (178.6mm/hr Intensity for 100yr)

We have a requirement to provide a level of quality control treatment to meet the **MOE 'Enhanced' Level of Protection** guidelines (i.e. **80% TSS removal** and **90% of annual runoff treated**). The proposed unit will be installed on a new 250mm dia. PVC pipe with approximately 1.7m cover on the pipe. A standard particle distribution (**Fines**) should be adequate for the design. Anticipated peak flows should be in the order of 21.5 L/s based on the City's requirement to control the site to a predevelopment level of the 5-yr allowable to the municipal sewer. As a result, there will be a significant amount upstream attenuation due to internal SWM tank and rooftop controls.

Can you please size a CDS unit for us and provide the design details as well as an approximate cost estimate.

We will also need the following information on the unit for our SWM Report:

- **% of net annual TSS removal**
- **% of net annual treatment volume for the tributary area**
- **The treatment capacity in L/s**
- **The sediment storage capacity in m<sup>3</sup>**
- **The oil storage capacity in L**
- **The total unit storage capacity in L**

Thank you for your time and consideration in this matter. Your quick response to this email would be greatly appreciated as we are aiming to submit the drawings for the city approval this week. If there is any further information you require, please do not hesitate to call.

Regards,

**Miroslav Savic**, P.Eng., Senior Project Manager | Land Development Engineering

**NOVATECH** Engineers, Planners & Landscape Architects

240 Michael Cowpland Drive, Suite 200, Ottawa, ON, K2M 1P6 | Tel: 613.254.9643 x 265 | Fax: 613.254.5867

The information contained in this email message is confidential and is for exclusive use of the addressee.



**CDS ESTIMATED NET ANNUAL SOLIDS LOAD REDUCTION  
BASED ON THE RATIONAL RAINFALL METHOD  
BASED ON A FINE PARTICLE SIZE DISTRIBUTION**



**Project Name:** 1765 Montreal Road

**Engineer:** Novatech

**Location:** Ottawa, ON

**Contact:** Miroslav Savic, P.Eng

**OGS #:** OGS

**Report Date:** 12-Dec-22

**Area** 0.398 ha

**Rainfall Station #** 215

**Weighted C** 0.83

**Particle Size Distribution** FINE

**CDS Model** 2015-4

**CDS Treatment Capacity** 20 l/s

<u>Rainfall Intensity<sup>1</sup></u> <u>(mm/hr)</u>	<u>Percent Rainfall Volume<sup>1</sup></u>	<u>Cumulative Rainfall Volume</u>	<u>Total Flowrate (l/s)</u>	<u>Treated Flowrate (l/s)</u>	<u>Operating Rate (%)</u>	<u>Removal Efficiency (%)</u>	<u>Incremental Removal (%)</u>
1.0	10.6%	19.8%	0.9	0.9	4.6	97.5	10.4
1.5	9.9%	29.7%	1.4	1.4	6.9	96.9	9.6
2.0	8.4%	38.1%	1.8	1.8	9.3	96.2	8.1
2.5	7.7%	45.8%	2.3	2.3	11.6	95.5	7.3
3.0	5.9%	51.7%	2.8	2.8	13.9	94.9	5.6
3.5	4.4%	56.1%	3.2	3.2	16.2	94.2	4.1
4.0	4.7%	60.7%	3.7	3.7	18.5	93.5	4.4
4.5	3.3%	64.0%	4.1	4.1	20.8	92.9	3.1
5.0	3.0%	67.1%	4.6	4.6	23.2	92.2	2.8
6.0	5.4%	72.4%	5.5	5.5	27.8	90.9	4.9
7.0	4.4%	76.8%	6.4	6.4	32.4	89.6	3.9
8.0	3.5%	80.3%	7.3	7.3	37.1	88.2	3.1
9.0	2.8%	83.2%	8.3	8.3	41.7	86.9	2.5
10.0	2.2%	85.3%	9.2	9.2	46.3	85.6	1.9
15.0	7.0%	92.3%	13.8	13.8	69.5	78.9	5.5
20.0	4.5%	96.9%	18.4	18.4	92.6	72.3	3.3
25.0	1.4%	98.3%	23.0	19.8	100.0	60.6	0.9
30.0	0.7%	99.0%	27.6	19.8	100.0	50.5	0.3
35.0	0.5%	99.5%	32.1	19.8	100.0	43.3	0.2
40.0	0.5%	100.0%	36.7	19.8	100.0	37.9	0.2
45.0	0.0%	100.0%	41.3	19.8	100.0	33.7	0.0
50.0	0.0%	100.0%	45.9	19.8	100.0	30.3	0.0

91.0

Removal Efficiency Adjustment<sup>2</sup> = 6.5%

**Predicted Net Annual Load Removal Efficiency = 84.5%**

**Predicted Annual Rainfall Treated = 98.6%**

1 - Based on 42 years of hourly rainfall data from Canadian Station 6105976, Ottawa ON

2 - Reduction due to use of 60-minute data for a site that has a time of concentration less than 30-minutes.

3 - CDS Efficiency based on testing conducted at the University of Central Florida

4 - CDS design flowrate and scaling based on standard manufacturer model & product specifications

## CDS PMSU2015-4-C DESIGN NOTES

THE STANDARD CDS PMSU2015-4-C CONFIGURATION IS SHOWN. ALTERNATE CONFIGURATIONS ARE AVAILABLE AND ARE LISTED BELOW. SOME CONFIGURATIONS MAY BE COMBINED TO SUIT SITE REQUIREMENTS.

### CONFIGURATION DESCRIPTION

- GRATED INLET ONLY (NO INLET PIPE)
- GRATED INLET WITH INLET PIPE OR PIPES
- CURB INLET ONLY (NO INLET PIPE)
- CURB INLET WITH INLET PIPE OR PIPES
- CUSTOMIZABLE SUMP DEPTH AVAILABLE
- ANTI-FLOTATION DESIGN AVAILABLE UPON REQUEST

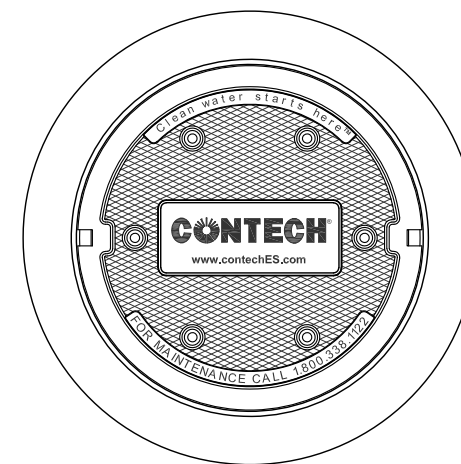
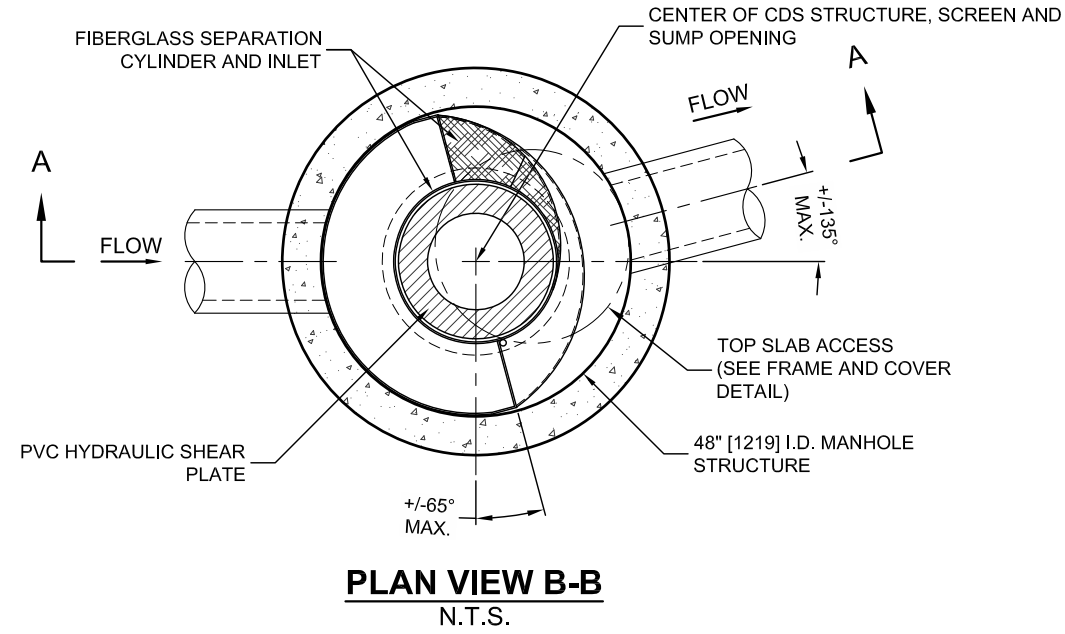

### SITE SPECIFIC DATA REQUIREMENTS

STRUCTURE ID				
WATER QUALITY FLOW RATE (CFS OR L/s)				*
PEAK FLOW RATE (CFS OR L/s)				*
RETURN PERIOD OF PEAK FLOW (YRS)				*
SCREEN APERTURE (2400 OR 4700)				*
PIPE DATA:	I.E.	MATERIAL	DIAMETER	
INLET PIPE 1	*	*	*	
INLET PIPE 2	*	*	*	
OUTLET PIPE	*	*	*	
RIM ELEVATION				*
ANTI-FLOTATION BALLAST	*	*	*	*
NOTES/SPECIAL REQUIREMENTS:				
* PER ENGINEER OF RECORD				

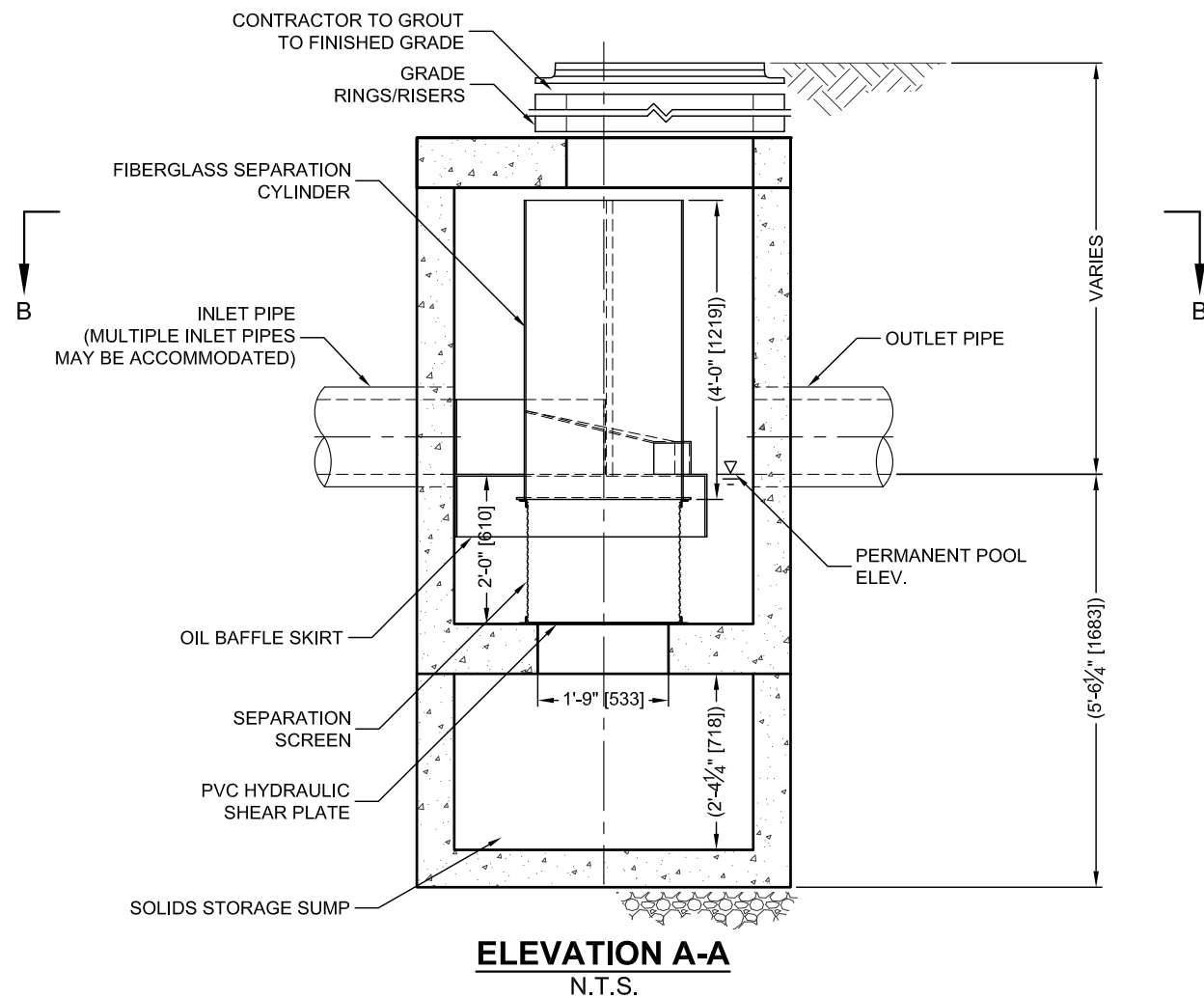

### GENERAL NOTES

1. CONTECH TO PROVIDE ALL MATERIALS UNLESS NOTED OTHERWISE.
2. DIMENSIONS MARKED WITH ( ) ARE REFERENCE DIMENSIONS. ACTUAL DIMENSIONS MAY VARY.
3. FOR FABRICATION DRAWINGS WITH DETAILED STRUCTURE DIMENSIONS AND WEIGHTS, PLEASE CONTACT YOUR CONTECH ENGINEERED SOLUTIONS LLC REPRESENTATIVE. [www.contechES.com](http://www.contechES.com)
4. CDS WATER QUALITY STRUCTURE SHALL BE IN ACCORDANCE WITH ALL DESIGN DATA AND INFORMATION CONTAINED IN THIS DRAWING.
5. STRUCTURE SHALL MEET AASHTO HS20 AND CASTINGS SHALL MEET HS20 (AASHTO M 306) LOAD RATING, ASSUMING GROUNDWATER ELEVATION AT, OR BELOW, THE OUTLET PIPE INVERT ELEVATION. ENGINEER OF RECORD TO CONFIRM ACTUAL GROUNDWATER ELEVATION.
6. PVC HYDRAULIC SHEAR PLATE IS PLACED ON SHELF AT BOTTOM OF SCREEN CYLINDER. REMOVE AND REPLACE AS NECESSARY DURING MAINTENANCE CLEANING.

### INSTALLATION NOTES

- A. ANY SUB-BASE, BACKFILL DEPTH, AND/OR ANTI-FLOTATION PROVISIONS ARE SITE-SPECIFIC DESIGN CONSIDERATIONS AND SHALL BE SPECIFIED BY ENGINEER OF RECORD.
- B. CONTRACTOR TO PROVIDE EQUIPMENT WITH SUFFICIENT LIFTING AND REACH CAPACITY TO LIFT AND SET THE CDS MANHOLE STRUCTURE (LIFTING CLUTCHES PROVIDED).
- C. CONTRACTOR TO ADD JOINT SEALANT BETWEEN ALL STRUCTURE SECTIONS, AND ASSEMBLE STRUCTURE.
- D. CONTRACTOR TO PROVIDE, INSTALL, AND GROUT PIPES. MATCH PIPE INVERTS WITH ELEVATIONS SHOWN.
- E. CONTRACTOR TO TAKE APPROPRIATE MEASURES TO ASSURE UNIT IS WATER TIGHT, HOLDING WATER TO FLOWLINE INVERT MINIMUM. IT IS SUGGESTED THAT ALL JOINTS BELOW PIPE INVERTS ARE GROUTED.



[www.contechES.com](http://www.contechES.com)  
9025 Centre Pointe Dr., Suite 400, West Chester, OH 45069  
800-338-1122 513-645-7000 513-645-7993 FAX

CDS PMSU2015-4-C  
INLINE CDS  
STANDARD DETAIL



THIS PRODUCT MAY BE PROTECTED BY ONE OR MORE OF THE FOLLOWING U.S. PATENTS: 6,788,848; 6,841,722; 6,911,502; 6,981,783; RELATED FOREIGN PATENTS, OR OTHER PATENT PENDING.

# CDS Guide

## Operation, Design, Performance and Maintenance



## CDS®

Using patented continuous deflective separation technology, the CDS system screens, separates and traps debris, sediment, and oil and grease from stormwater runoff. The indirect screening capability of the system allows for 100% removal of floatables and neutrally buoyant material without blinding. Flow and screening controls physically separate captured solids, and minimize the re-suspension and release of previously trapped pollutants. Inline units can treat up to 6 cfs, and internally bypass flows in excess of 50 cfs. Available precast or cast-in-place, offline units can treat flows from 1 to 300 cfs. The pollutant removal capacity of the CDS system has been proven in lab and field testing.

### Operation Overview

Stormwater enters the diversion chamber where the diversion weir guides the flow into the unit's separation chamber and pollutants are removed from the flow. All flows up to the system's treatment design capacity enter the separation chamber and are treated.

Swirl concentration and screen deflection force floatables and solids to the center of the separation chamber where 100% of floatables and neutrally buoyant debris larger than the screen apertures are trapped.

Stormwater then moves through the separation screen, under the oil baffle and exits the system. The separation screen remains clog free due to continuous deflection.

During the flow events exceeding the design capacity, the diversion weir bypasses excessive flows around the separation chamber, so captured pollutants are retained in the separation cylinder.

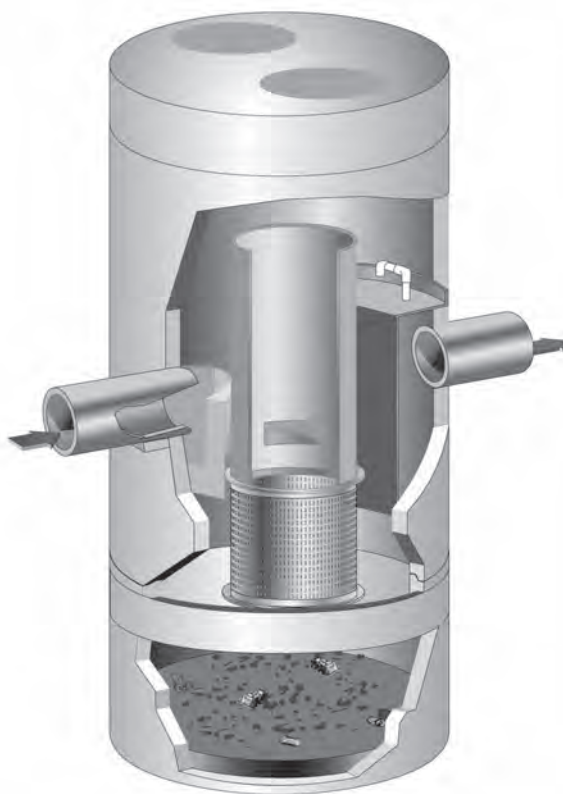

## Design Basics

There are three primary methods of sizing a CDS system. The Water Quality Flow Rate Method determines which model size provides the desired removal efficiency at a given flow rate for a defined particle size. The Rational Rainfall Method™ and Probabalistic Method are used when a specific removal efficiency of the net annual sediment load is required.

Typically in the Unites States, CDS systems are designed to achieve an 80% annual solids load reduction based on lab generated performance curves for a gradation with an average particle size (d50) of 125-microns ( $\mu\text{m}$ ). For some regulatory environments, CDS systems can also be designed to achieve an 80% annual solids load reduction based on an average particle size (d50) of 75-microns ( $\mu\text{m}$ ).

### Water Quality Flow Rate Method

In many cases, regulations require that a specific flow rate, often referred to as the water quality design flow (WQQ), be treated. This WQQ represents the peak flow rate from either an event with a specific recurrence interval (i.e. the six-month storm) or a water quality depth (i.e. 1/2-inch of rainfall).

The CDS is designed to treat all flows up to the WQQ. At influent rates higher than the WQQ, the diversion weir will direct most flow exceeding the treatment flow rate around the separation chamber. This allows removal efficiency to remain relatively constant in the separation chamber and reduces the risk of washout during bypass flows regardless of influent flow rates.

Treatment flow rates are defined as the rate at which the CDS will remove a specific gradation of sediment at a specific removal efficiency. Therefore they are variable based on the gradation and removal efficiency specified by the design engineer.

### Rational Rainfall Method™

Differences in local climate, topography and scale make every site hydraulically unique. It is important to take these factors into consideration when estimating the long-term performance of any stormwater treatment system. The Rational Rainfall Method combines site-specific information with laboratory generated performance data, and local historical precipitation records to estimate removal efficiencies as accurately as possible.

Short duration rain gauge records from across the United States and Canada were analyzed to determine the percent of the total annual rainfall that fell at a range of intensities. US stations' depths were totaled every 15 minutes, or hourly, and recorded in 0.01-inch increments. Depths were recorded hourly with 1-mm resolution at Canadian stations. One trend was consistent at all sites; the vast majority of precipitation fell at low intensities and high intensity storms contributed relatively little to the total annual depth.

These intensities, along with the total drainage area and runoff coefficient for each specific site, are translated into flow rates using the Rational Rainfall Method. Since most sites are relatively small and highly impervious, the Rational Rainfall Method is appropriate. Based on the runoff flow rates calculated for each intensity, operating rates within a proposed CDS system are determined. Performance efficiency curve determined from full scale laboratory tests on defined sediment PSDs is applied to

calculate solids removal efficiency. The relative removal efficiency at each operating rate is added to produce a net annual pollutant removal efficiency estimate.

### Probabilistic Rational Method

The Probabilistic Rational Method is a sizing program CONTECH developed to estimate a net annual sediment load reduction for a particular CDS model based on site size, site runoff coefficient, regional rainfall intensity distribution, and anticipated pollutant characteristics.

The Probabilistic rational method is an extension of the rational method used to estimate peak discharge rates generated by storm events of varying statistical return frequencies (i.e.: 2-year storm event). Under this method, an adjustment factor is used to adjust the runoff coefficient estimated for the 10-year event, correlating a known hydrologic parameter with the target storm event. The rainfall intensities vary depending on the return frequency of the storm event under consideration. In general, these two frequency dependent parameters increase as the return frequency increases while the drainage area remains constant.

These intensities, along with the total drainage area and runoff coefficient for each specific site, are translated into flow rates using the Rational Method. Since most sites are relatively small and highly impervious, the Rational Method is appropriate. Based on the runoff flow rates calculated for each intensity, operating rates within a proposed CDS are determined. Performance efficiency curve on defined sediment PSDs is applied to calculate solids removal efficiency. The relative removal efficiency at each operating rate is added to produce a net annual pollutant removal efficiency estimate.

### Treatment Flow Rate

The inlet throat area is sized to ensure that the WQQ passes through the separation chamber at a water surface elevation equal to the crest of the diversion weir. The diversion weir bypasses excessive flows around the separation chamber, thus helping to prevent re-suspension or re-entrainment of previously captured particles.

### Hydraulic Capacity

CDS hydraulic capacity is determined by the length and height of the diversion weir and by the maximum allowable head in the system. Typical configurations allow hydraulic capacities of up to ten times the treatment flow rate. As needed, the crest of the diversion weir may be lowered and the inlet throat may be widened to increase the capacity of the system at a given water surface elevation. The unit is designed to meet project specific hydraulics.

## Performance

### Full-Scale Laboratory Test Results

A full-scale CDS unit (Model CDS2020-5B) was tested at the facility of University of Florida, Gainesville, FL. This full-scale CDS unit was evaluated under controlled laboratory conditions of pumped influent and the controlled addition of sediment.

Two different gradations of silica sand material (UF Sediment & OK-110) were used in the CDS performance evaluation. The particle size distributions (PSD) of the test materials were

analyzed using standard method "Gradation ASTM D-422 with Hydrometer" by a certified laboratory. UF Sediment is a mixture of three different U.S. Silica Sand products referred as: "Sil-Co-Sil 106", "#1 DRY" and "20/40 Oil Frac". Particle size distribution analysis shows that the UF Sediment has a very fine gradation ( $d_{50} = 20$  to  $30 \mu\text{m}$ ) covering a wide size range (uniform coefficient  $C_u$  averaged at 10.6). In comparison with the hypothetical TSS gradation specified in the NJDEP (New Jersey Department of Environmental Protection) and NJCAT (New Jersey Corporation for Advanced Technology) protocol for lab testing, the UF Sediment covers a similar range of particle size but with a finer  $d_{50}$  ( $d_{50}$  for NJDEP is approximately  $50 \mu\text{m}$ ) (NJDEP, 2003). The OK-110 silica sand is a commercial product of U.S. Silica Sand. The particle size distribution analysis of this material, also included in Figure 1, shows that 99.9% of the OK-110 sand is finer than 250 microns, with a mean particle size ( $d_{50}$ ) of 106 microns. The PSDs for the test material are shown in Figure 1.

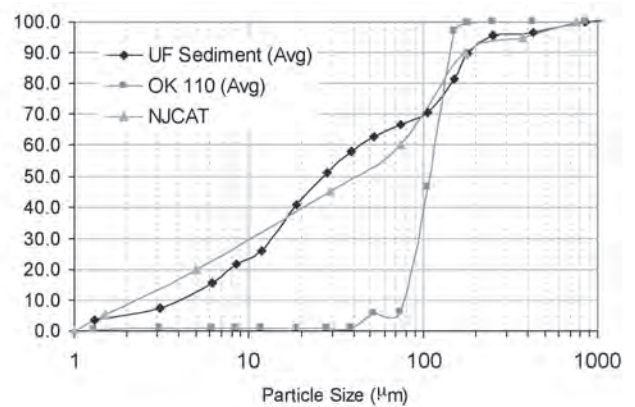

Figure 1. Particle size distributions for the test materials, as compared to the NJCAT/NJDEP theoretical distribution.

Tests were conducted to quantify the CDS unit (1.1 cfs (31.3-L/s) design capacity) performance at various flow rates, ranging from 1% up to 125% of the design capacity of the unit, using the 2400 micron screen. All tests were conducted with controlled influent concentrations approximately 200 mg/L. Effluent samples were taken at equal time intervals across the entire duration of each test run. These samples were then processed with a Dekaport Cone sample splitter to obtain representative sub-samples for Suspended Sediment Concentration (SSC – ASTM Standard Method D3977-97) and particle size distribution analysis.

## Results and Modeling

Based on the testing data from the University of Florida, a performance model was developed for the CDS system. A regression analysis was used to develop a fitting curve for the scattered data points at various design flow rates. This model, which demonstrated good agreement with the laboratory data, can then be used to predict CDS system performance with respect to SSC removal for any particle size gradation assuming sandy-silt type of inorganic components of SSC. Figure 2 shows CDS predictive performance for two typical particle size gradations (NJCAT gradation and OK-110 sand).

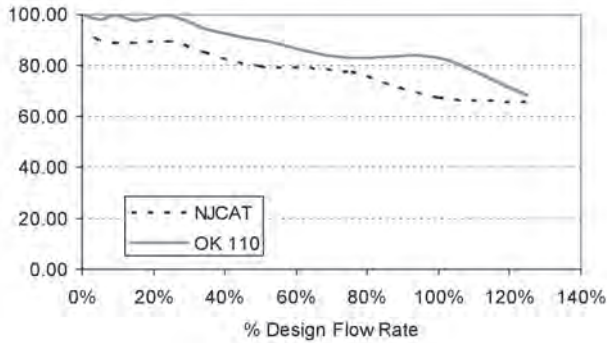

Figure 2. CDS stormwater treatment predictive performance for various particle gradations as a function of operating rate.

Many regulatory jurisdictions set a performance standard for hydrodynamic devices by stating that the devices shall be capable of achieving an 80% removal efficiency for particles having a mean particle size (d50) of 125 microns (WADOE, 2008). The model can be used to calculate the expected performance of such a PSD (shown in Figure 3). Supported by the laboratory data, the model indicates (Figure 4) that the CDS system with 2400 micron screen achieves approximately 80% removal at 100% of design flow rate, for this particle size distribution (d50 = 125 μm).

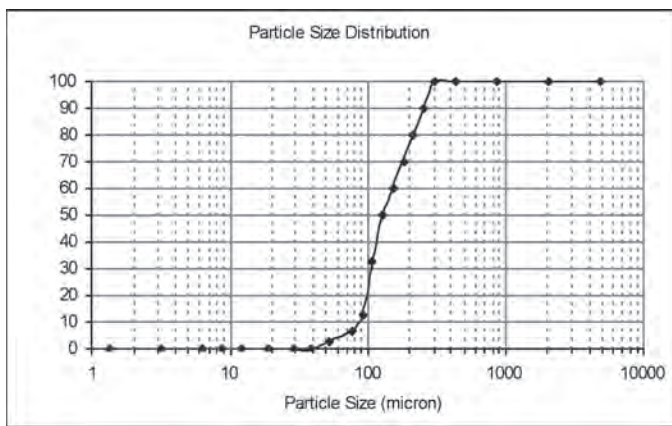

Figure 3. PSD with d50 = 125 microns, used to model performance for Ecology submittal.

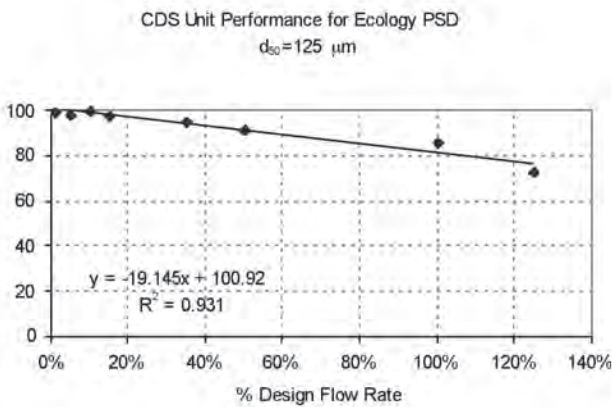

Figure 4. Modeled performance for CDS unit with 2400 microns screen, using Ecology PSD.

## Maintenance

The CDS system should be inspected at regular intervals and maintained when necessary to ensure optimum performance. The rate at which the system collects pollutants will depend more heavily on site activities than the size of the unit, e.g., unstable soils or heavy winter sanding will cause the grit chamber to fill more quickly but regular sweeping of paved surfaces will slow accumulation.

## Inspection

Inspection is the key to effective maintenance and is easily performed. Pollutant deposition and transport may vary from year to year and regular inspections will help insure that the system is cleaned out at the appropriate time. At a minimum, inspections should be performed twice per year (i.e. spring and fall) however more frequent inspections may be necessary in climates where winter sanding operations may lead to rapid accumulations, or in equipment washdown areas. Additionally, installations should be inspected more frequently where excessive amounts of trash are expected.

The visual inspection should ascertain that the system components are in working order and that there are no blockages or obstructions to inlet and/or separation screen. The inspection should also identify evidence of vector infestation and accumulations of hydrocarbons, trash, and sediment in the system. Measuring pollutant accumulation can be done with a calibrated dipstick, tape measure or other measuring instrument. If sorbent material is used for enhanced removal of hydrocarbons then the level of discoloration of the sorbent material should also





be identified during inspection. It is useful and often required as part of a permit to keep a record of each inspection. A simple form for doing so is provided.

Access to the CDS unit is typically achieved through two manhole access covers. One opening allows for inspection and cleanout of the separation chamber (screen/cylinder) and isolated sump. The other allows for inspection and cleanout of sediment captured and retained behind the screen. For units possessing a sizable depth below grade (depth to pipe), a single manhole access point would allow both sump cleanout and access behind the screen.

The CDS system should be cleaned when the level of sediment has reached 75% of capacity in the isolated sump and/or when an appreciable level of hydrocarbons and trash has accumulated. If sorbent material is used, it should be replaced when significant discoloration has occurred. Performance will not be impacted until 100% of the sump capacity is exceeded however it is recommended that the system be cleaned prior to that for easier removal of sediment. The level of sediment is easily determined by measuring from finished grade down to the top of the sediment pile. To avoid underestimating the level of sediment in the chamber, the measuring device must be lowered to the top of the sediment pile carefully. Finer, silty particles at the top of the pile typically offer less resistance to the end of the rod than larger particles toward the bottom of the pile. Once this measurement is recorded, it should be compared to the as-built drawing for the unit to determine if the height of the sediment pile off the bottom of the sump floor exceeds 75% of the total height of isolated sump.

## Cleaning

Cleaning of the CDS systems should be done during dry weather conditions when no flow is entering the system. Cleanout of the CDS with a vacuum truck is generally the most effective and convenient method of excavating pollutants from the system. Simply remove the manhole covers and insert the vacuum hose into the sump. The system should be completely drained down and the sump fully evacuated of sediment. The area outside the screen should be pumped out also if pollutant build-up exists in this area.

In installations where the risk of petroleum spills is small, liquid contaminants may not accumulate as quickly as sediment. However, an oil or gasoline spill should be cleaned out immediately. Motor oil and other hydrocarbons that accumulate on a more routine basis should be removed when an appreciable layer has been captured. To remove these pollutants, it may be preferable to use adsorbent pads since they are usually less expensive to dispose than the oil/water emulsion that may be created by vacuuming the oily layer. Trash can be netted out if you wish to separate it from the other pollutants. The screen should be power washed to ensure it is free of trash and debris.

Manhole covers should be securely seated following cleaning activities to prevent leakage of runoff into the system from above and also to ensure proper safety precautions. Confined Space Entry procedures need to be followed. Disposal of all material removed from the CDS system should be done in accordance with local regulations. In many locations, disposal of evacuated sediments may be handled in the same manner as disposal of sediments removed from catch basins or deep sump manholes. Check your local regulations for specific requirements on disposal.



CDS Model	Diameter		Distance from Water Surface to Top of Sediment Pile		Sediment Storage Capacity	
	ft	m	ft	m	yd <sup>3</sup>	m <sup>3</sup>
CDS2015-4	4	1.2	3.0	0.9	0.5	0.4
CDS2015	5	1.5	3.0	0.9	1.3	1.0
CDS2020	5	1.5	3.5	1.1	1.3	1.0
CDS2025	5	1.5	4.0	1.2	1.3	1.0
CDS3020	6	1.8	4.0	1.2	2.1	1.6
CDS3030	6	1.8	4.6	1.4	2.1	1.6
CDS3035	6	1.8	5.0	1.5	2.1	1.6
CDS4030	8	2.4	4.6	1.4	5.6	4.3
CDS4040	8	2.4	5.7	1.7	5.6	4.3
CDS4045	8	2.4	6.2	1.9	5.6	4.3

Table 1: CDS Maintenance Indicators and Sediment Storage Capacities

Note: To avoid underestimating the volume of sediment in the chamber, carefully lower the measuring device to the top of the sediment pile. Finer silty particles at the top of the pile may be more difficult to feel with a measuring stick. These finer particles typically offer less resistance to the end of the rod than larger particles toward the bottom of the pile.



# CDS Inspection & Maintenance Log

CDS Model: \_\_\_\_\_ Location: \_\_\_\_\_

Date	Water depth to sediment <sup>1</sup>	Floatable Layer Thickness <sup>2</sup>	Describe Maintenance Performed	Maintenance Personnel	Comments

1. The water depth to sediment is determined by taking two measurements with a stadia rod: one measurement from the manhole opening to the top of the sediment pile and the other from the manhole opening to the water surface. If the difference between these measurements is less than eighteen inches the system should be cleaned out. **Note: To avoid underestimating the volume of sediment in the chamber, the measuring device must be carefully lowered to the top of the sediment pile.**
2. For optimum performance, the system should be cleaned out when the floating hydrocarbon layer accumulates to an appreciable thickness. In the event of an oil spill, the system should be cleaned immediately.

## Support

- Drawings and specifications are available at [www.contechstormwater.com](http://www.contechstormwater.com).
- Site-specific design support is available from our engineers.



800.925.5240

[contechstormwater.com](http://contechstormwater.com)

©2008 CONTECH Stormwater Solutions

CONTECH Construction Products Inc. provides site solutions for the civil engineering industry. CONTECH's portfolio includes bridges, drainage, sanitary sewer, stormwater and earth stabilization products. For information on other CONTECH division offerings, visit [contech-cpi.com](http://contech-cpi.com) or call 800.338.1122

Nothing in this catalog should be construed as an expressed warranty or an implied warranty of merchantability or fitness for any particular purpose. See the CONTECH standard quotation or acknowledgement for applicable warranties and other terms and conditions of sale.

The product(s) described may be protected by one or more of the following US patents: 5,322,629; 5,624,576; 5,707,527; 5,759,415; 5,788,848; 5,985,157; 6,027,639; 6,350,374; 6,406,218; 6,641,720; 6,511,595; 6,649,048; 6,991,114; 6,998,038; 7,186,058; 7,296,692; 7,297,266; related foreign patents or other patents pending.

## **APPENDIX H**

### **Drawings**

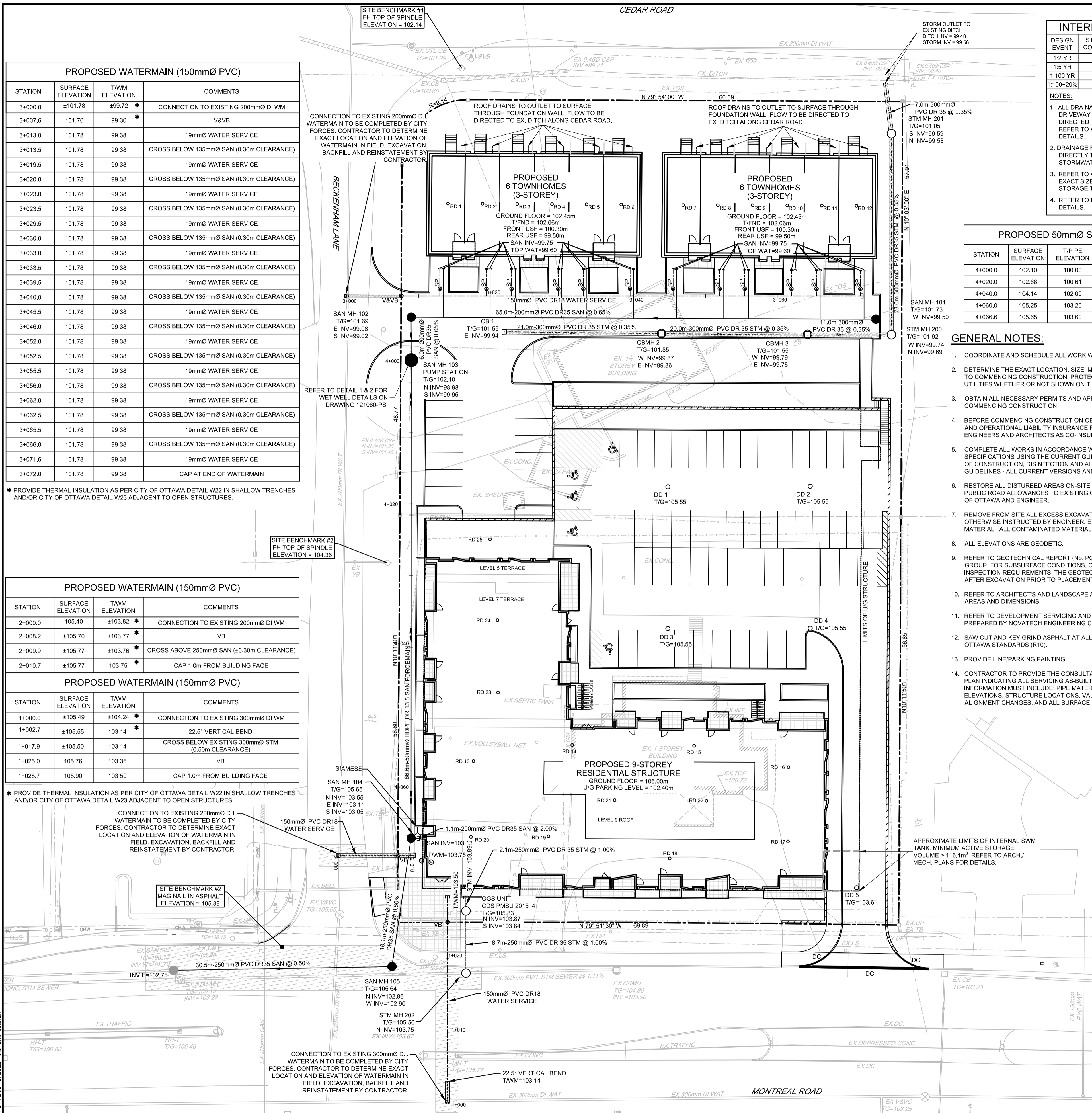

INTERNAL SWM STORAGE SYSTEM			
DESIGN EVENT	STORAGE SYSTEM CONTROLLED FLOW	STORAGE VOLUMES REQUIRED	STORAGE VOLUMES PROVIDED
1:2 YR	15.1 L/s	21.4 m³	116.4 m³
1:5 YR	15.1 L/s	34.9 m³	
1:100 YR	15.1 L/s	90.4 m³	
1:100+20%	15.1 L/s	116.4 m³	

**NOTES:**

- ALL DRAINAGE FROM AREA A-7 (PROPOSED PARKING LOT, DRIVEWAY DECK DRAINS 1-5, AND ROOF DRAINS 23-25) TO BE DIRECTED TO THE INTERNAL STORMWATER STORAGE TANK. REFER TO ARCHITECTURAL AND MECHANICAL PLANS FOR DETAILS.
- DRAINAGE FROM AREA A-5 (RD 13-22) TO BE CONNECTED DIRECTLY TO GRAVITY STORM SERVICE BY PASSING STORMWATER STORAGE TANK.
- REFER TO ARCHITECTURAL AND STRUCTURAL PLANS FOR EXACT SIZE AND DETAILS OF INTERNAL STORMWATER STORAGE TANK.
- REFER TO MECHANICAL PLANS FOR PUMP INFORMATION AND DETAILS.

PROPOSED 50mmØ SANITARY FORCEMAIN TABLE			
STATION	SURFACE ELEVATION	PIPE ELEVATION	COMMENTS
4+000.0	102.10	100.00	EXTERIOR WALL OF FORCEMAIN VALVE CHAMBER
4+020.0	102.86	100.61	---
4+040.0	104.14	102.09	---
4+060.0	105.25	103.20	---
4+066.6	105.65	103.60	OUTLET TO SAN MH 104

**LEGEND:**

- RD 1: PROPOSED CONTROLLED FLOW ROOF DRAIN
- DD 1: PROPOSED AREA DECK DRAIN
- M: PROPOSED WATER METER AND REMOTE METER
- DC: PROPOSED DEPRESSED CURB
- V&V: PROPOSED WATER SERVICE
- SanMH: PROPOSED SANITARY MANHOLE
- CBMH: PROPOSED CATCHBASIN MANHOLE
- STMH: PROPOSED STORM MANHOLE
- CB: PROPOSED CATCHBASIN
- OHW: PROPOSED RETAINING WALL

**GENERAL NOTES:**

- COORDINATE AND SCHEDULE ALL WORK WITH OTHER TRADES AND CONTRACTORS.
- DETERMINE THE EXACT LOCATION, SIZE, MATERIAL AND ELEVATION OF ALL EXISTING UTILITIES PRIOR TO COMMENCING CONSTRUCTION. PROTECT AND ASSUME RESPONSIBILITY FOR ALL EXISTING UTILITIES WHETHER OR NOT SHOWN ON THIS DRAWING.
- OBTAIN ALL NECESSARY PERMITS AND APPROVALS FROM THE CITY OF OTTAWA BEFORE COMMENCING CONSTRUCTION.
- BEFORE COMMENCING CONSTRUCTION OBTAIN AND PROVIDE PROOF OF COMPREHENSIVE, ALL RISK AND OPERATIONAL LIABILITY INSURANCE FOR \$5,000,000.00. INSURANCE POLICY TO NAME OWNERS, ENGINEERS AND ARCHITECTS AS CO-INSURED.
- COMPLETE ALL WORKS IN ACCORDANCE WITH THE MOST CURRENT CITY OF OTTAWA STANDARDS AND SPECIFICATIONS USING THE CURRENT GUIDELINES, BYLAWS AND STATUTES INCLUDING MATERIALS OF CONSTRUCTION, DISINFECTION AND ALL RELEVANT REFERENCES TO OPSB, OPSD, & AWMA GUIDELINES - ALL CURRENT VERSIONS AND AS AMENDED.
- RESTORE ALL DISTURBED AREAS ON-SITE AND OFF-SITE, INCLUDING TRENCHES AND SURFACES ON PUBLIC ROAD ALLOWANCES TO EXISTING CONDITIONS OR BETTER TO THE SATISFACTION OF THE CITY OF OTTAWA AND ENGINEER.
- REMOVE FROM SITE ALL EXCESS EXCAVATED MATERIAL, ORGANIC MATERIAL AND DEBRIS UNLESS OTHERWISE INSTRUCTED BY ENGINEER. EXCAVATE AND REMOVE FROM SITE ANY CONTAMINATED MATERIAL. ALL CONTAMINATED MATERIAL SHALL BE DISPOSED OF AT A LICENSED LANDFILL FACILITY.
- ALL ELEVATIONS ARE GEODETIC.
- REFER TO GEOTECHNICAL REPORT (No. PG5736-1, DATED APRIL 23, 2021), PREPARED BY PATERSON GROUP, FOR SUBSURFACE CONDITIONS, CONSTRUCTION RECOMMENDATIONS, AND GEOTECHNICAL INSPECTION REQUIREMENTS. THE GEOTECHNICAL CONSULTANT IS TO REVIEW ON-SITE CONDITIONS AFTER EXCAVATION PRIOR TO PLACEMENT OF THE GRANULAR MATERIAL.
- REFER TO ARCHITECT'S AND LANDSCAPE ARCHITECT'S DRAWINGS FOR BUILDING AND HARDSURFACE AREAS AND DIMENSIONS.
- REFER TO DEVELOPMENT SERVICING AND STORMWATER MANAGEMENT REPORT(R-2022-206) PREPARED BY NOVATECH ENGINEERING CONSULTANTS LTD.
- SAW CUT AND KEY GRIND ASPHALT AT ALL ROAD CUTS AND ASPHALT TIE IN POINTS AS PER CITY OF OTTAWA STANDARDS (R10).
- PROVIDE LINE/PARKING PAINTING.
- CONTRACTOR TO PROVIDE THE CONSULTANT WITH A GENERAL PLAN OF SERVICES AND GRADING PLAN INDICATING ALL SERVICING AS-BUILT INFORMATION SHOWN ON THE PLANS. AS-BUILT INFORMATION MUST INCLUDE: PIPE MATERIALS, SIZES, LENGTHS, SLOPES, INVERT AND TIG ELEVATIONS, STRUCTURE LOCATIONS, VALVE AND HYDRANT LOCATIONS, TWM ELEVATIONS, ANY ALIGNMENT CHANGES, AND ALL SURFACE ELEVATION AS BUILT GRADES.

COVER (mm)	INSULATION THICKNESS (mm)
2000-1500	50
1500-1200	75
1200-900	100
900-600	125

**NOTES:**

- INSULATE ALL SEWER PIPES THAT HAVE LESS THAN 2.0m COVER WITH EXPANDED POLYSTYRENE INSULATION AS SHOWN.
- THE THICKNESS OF INSULATION SHALL BE THE EQUIVALENT OF 25mm FOR EVERY 300mm REDUCTION IN THE REQUIRED DEPTH OF COVER (SEE TABLE).

**SEWER NOTES:**

- SPECIFICATIONS: ITEM, SPEC. No., REFERENCE.

ITEM	SPEC. No.	REFERENCE
CATCHBASIN (600x600mm)	705.010	OPSD
STORM/SANITARY MANHOLE (1200Ø)	701.010	OPSD
CB FRAME & COVER	401.020	OPSD
STORM/SANITARY MH FRAME & COVER	401.010	OPSD
SEWER TRENCH	S8	CITY OF OTTAWA
STORM SEWER	PVC DR 35	
SANITARY SEWER	PVC DR 35	

**WATERMAIN NOTES:**

- SPECIFICATIONS: ITEM, SPEC. No., REFERENCE.

ITEM	SPEC. No.	REFERENCE
WATERMAIN TRENCHING	W17	CITY OF OTTAWA
THERMAL INSULATION IN SHALLOW TRENCHES	W22	CITY OF OTTAWA
WATERMAIN CROSSING BELOW SEWER	W25	CITY OF OTTAWA
WATERMAIN	PVC DR 18	

**PROPOSED WATERMAIN (150mmØ PVC)**

STATION	SURFACE ELEVATION	TWM ELEVATION	COMMENTS
2+000.0	105.40	±103.82	CONNECTION TO EXISTING 200mmØ DI WM
2+008.2	±105.70	±103.77	VB
2+009.9	±105.77	±103.76	CROSS ABOVE 250mmØ SAN (±0.30m CLEARANCE)
2+010.7	±105.77	103.75	CAP 1.0m FROM BUILDING FACE

**PROPOSED WATERMAIN (150mmØ PVC)**

STATION	SURFACE ELEVATION	TWM ELEVATION	COMMENTS
1+000.0	±105.49	±104.24	CONNECTION TO EXISTING 300mmØ DI WM
1+002.7	±105.55	103.14	22.5° VERTICAL BEND
1+017.9	±105.50	103.14	CROSS BELOW EXISTING 300mmØ STM (0.50m CLEARANCE)
1+025.0	105.76	103.36	VB
1+028.7	105.90	103.50	CAP 1.0m FROM BUILDING FACE

**NOTE:** THE POSITION OF ALL POLE LINES, CONDUITS, WATERMANS, SEWERS AND OTHER UNDERGROUND AND OVERGROUND UTILITIES ON THE CONTRACT DRAWINGS, AND WHERE SHOWN, THE ACCURACY OF THE POSITION OF SUCH UTILITIES AND STRUCTURES IS NOT GUARANTEED, BEFORE STARTING WORK, DETERMINE THE EXACT LOCATION OF ALL SUCH UTILITIES AND STRUCTURES AND ASSUME ALL LIABILITY FOR DAMAGE TO THEM.

**OWNER INFORMATION**  
 LANDRICH HOMES  
 63 MONTREAL ROAD EAST  
 GATINEAU, QUEBEC, J8M 1K3  
 NAME: ERIC DANIS  
 PHONE: (819) 593-4805  
 ericdanis@constructionlaverendrye.com

No.	REVISION	DATE	BY
1.	ISSUED FOR SITE PLAN APPLICATION	DEC 2022	MS

**SCALE**  
1:300

DESIGN	LSC
CHECKED	MS
DRAWN	ZA
CHECKED	MS
APPROVED	MS

**FOR REVIEW ONLY**

Novatech  
 Engineers, Planners & Landscape Architects  
 Suite 200, 240 Michael Cowpland Drive  
 Ottawa, Ontario, Canada K2M 1P6

Telephone: (613) 254-9643  
 Facsimile: (613) 254-5867  
 Website: www.novatech-eng.com

**NOVATECH**

**GENERAL PLAN OF SERVICES**

LOCATION: CITY OF OTTAWA, 1765 MONTREAL ROAD

DRAWING NAME: GENERAL PLAN OF SERVICES

PROJECT No.: 121060

REV #1

DRAWING No.: 121060-GP

M:\2022\121060\CAD\Design\121060-GP.dwg, GP, Dec 19, 2022 - 9:31am, lcaabram

**EROSION AND SEDIMENT CONTROL NOTES:**

1. ALL EROSION AND SEDIMENT CONTROLS ARE TO BE INSTALLED TO THE SATISFACTION OF THE ENGINEER AND THE CITY OF OTTAWA. THEY ARE TO BE APPROPRIATE TO THE SITE CONDITIONS. PRIOR TO UNDERTAKING ANY SITE ALTERATIONS (FILLING, GRADING, REMOVAL OF VEGETATION, ETC.) AND DURING ALL PHASES OF SITE PREPARATION AND CONSTRUCTION, THESE PRACTICES ARE TO BE IMPLEMENTED IN ACCORDANCE WITH THE CURRENT BEST MANAGEMENT PRACTICES FOR EROSION AND SEDIMENT CONTROL AND SHOULD INCLUDE AS A MINIMUM THOSE MEASURES INDICATED ON THE PLAN.
2. TO PREVENT SURFACE EROSION FROM ENTERING ANY STORM SEWER SYSTEM DURING CONSTRUCTION, FILTER BAGS WILL BE PLACED UNDER GRATES OF NEARBY CATCH-BASINS AND STRUCTURES. A LIGHT DUTY SILT FENCE BARRIER WILL ALSO BE INSTALLED AROUND THE CONSTRUCTION AREA (WHERE APPLICABLE). THESE CONTROL MEASURES WILL REMAIN IN PLACE UNTIL CONSTRUCTION IS COMPLETE.
3. THE SEDIMENT CONTROL MEASURES SHALL ONLY BE REMOVED WHEN, IN THE OPINION OF THE ENGINEER, THE MEASURES ARE NO LONGER REQUIRED. NO CONTROL MEASURES MAY BE PERMANENTLY REMOVED WITHOUT PRIOR AUTHORIZATION FROM THE ENGINEER.
4. THE CONTRACTOR SHALL IMMEDIATELY REPORT TO THE ENGINEER ANY ACCIDENTAL DISCHARGES OF SEDIMENT MATERIAL INTO ANY STORM SEWER SYSTEM. APPROPRIATE RESPONSE MEASURES, INCLUDING ANY REPAIRS TO EXISTING CONTROL MEASURES OR THE IMPLEMENTATION OF ADDITIONAL CONTROL MEASURES, SHALL BE CARRIED OUT BY THE CONTRACTOR WITHOUT DELAY.
5. THE CONTRACTOR ACKNOWLEDGES THAT FAILURE TO IMPLEMENT EROSION AND SEDIMENT CONTROL MEASURES MAY BE SUBJECT TO PENALTIES IMPOSED BY ANY APPLICABLE REGULATORY AGENCY.
6. ROADWAYS ARE TO BE SWEEP AS REQUIRED OR AS DIRECTED BY THE ENGINEER AND/OR MUNICIPALITY.
7. THE CONTRACTOR SHALL ENSURE PROPER DUST CONTROL IS PROVIDED WITH THE APPLICATION OF WATER (AND IF REQUIRED, CALCIUM CHLORIDE) DURING DRY PERIODS.

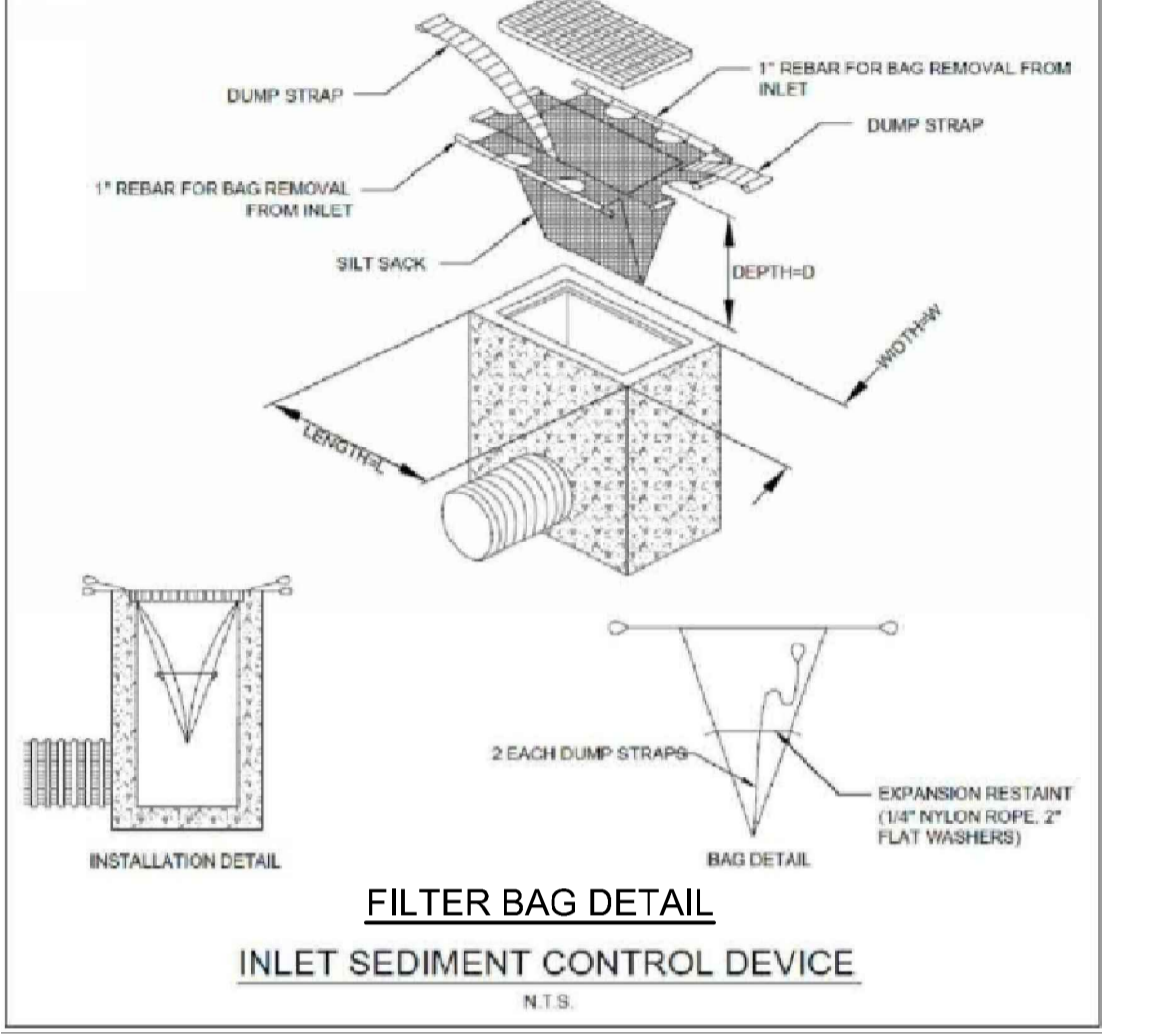
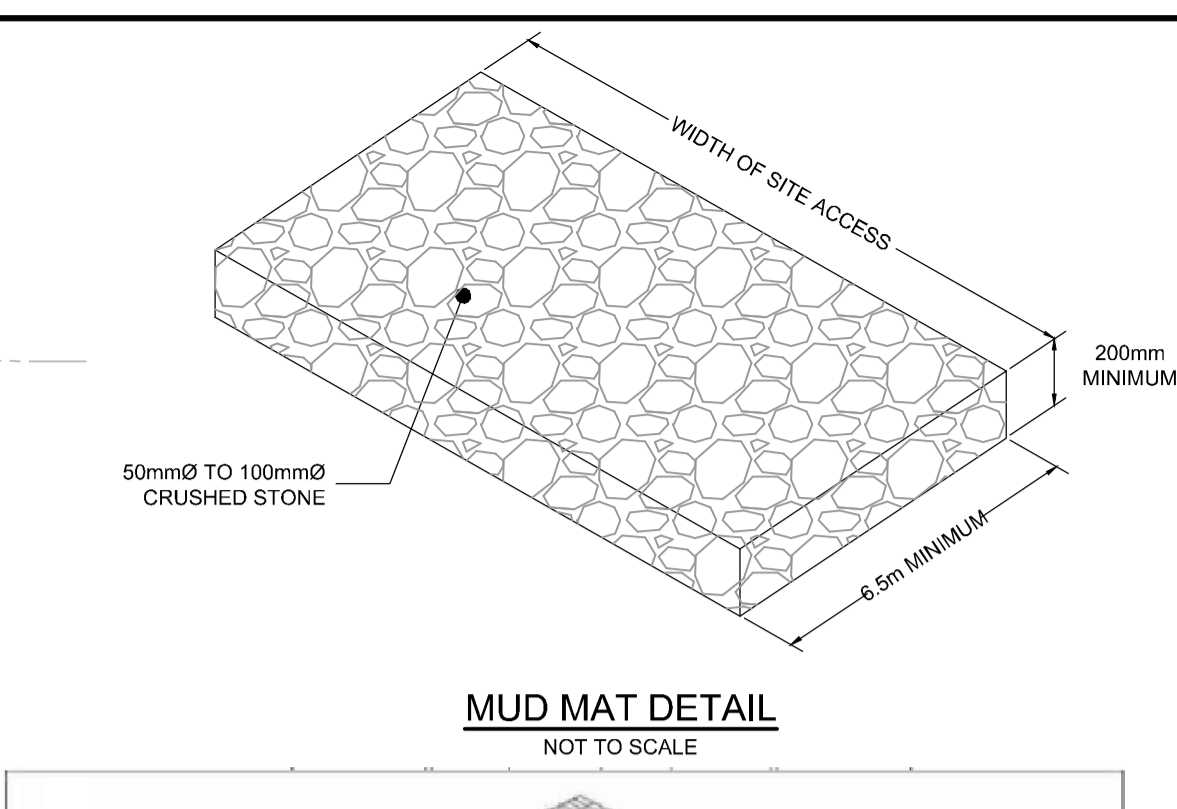
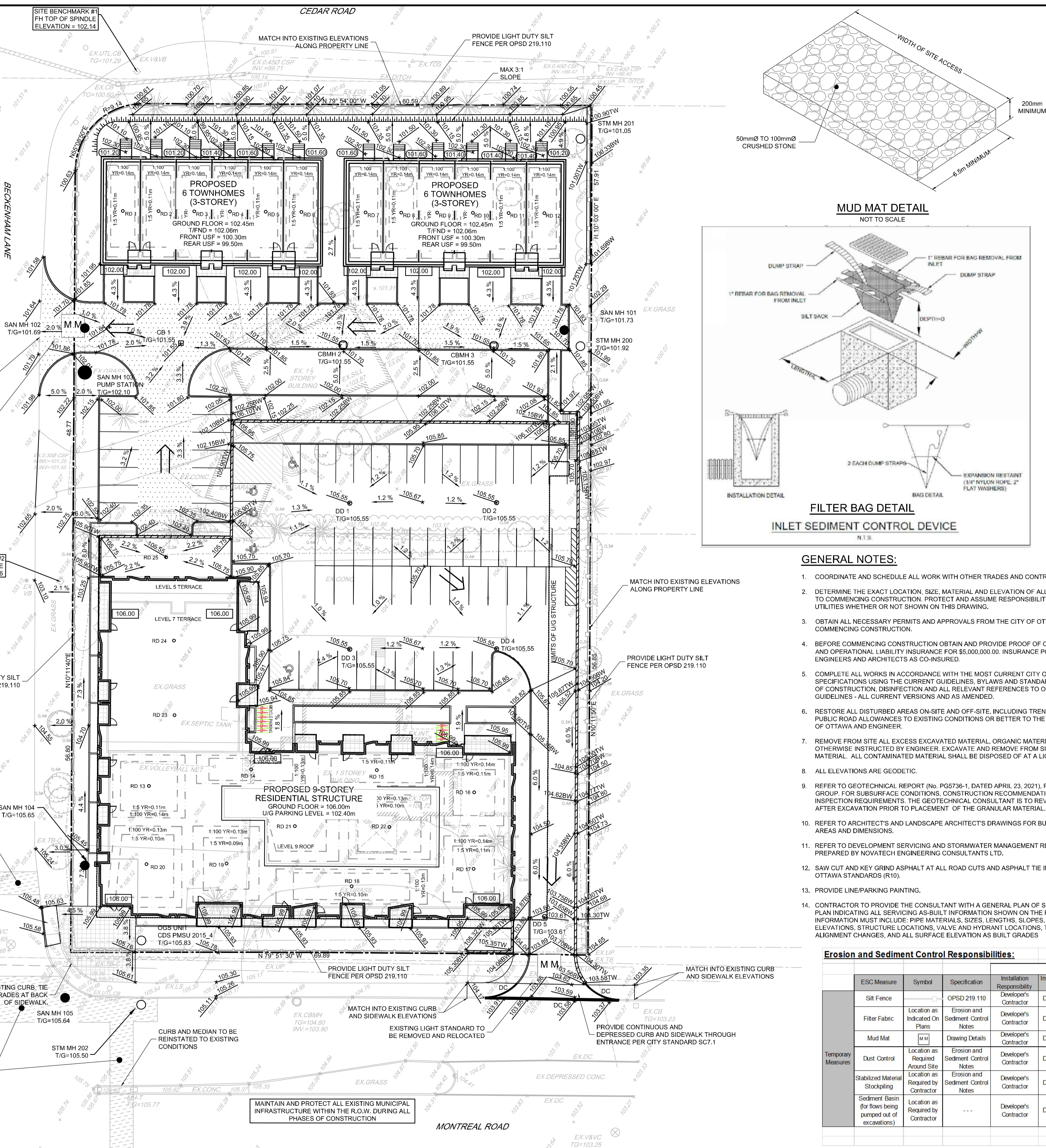

**LEGEND**

	PROPOSED ELEVATION		PROPOSED AREA DECK DRAIN
	EXISTING ELEVATION		PROPOSED RETAINING WALL
	GRADE AND DIRECTION		PROPOSED SAN MANHOLE
	MAXIMUM 3:1 SIDESLOPE		PROPOSED STORM MANHOLE
	PROPOSED SILT FENCING (OPSD 219.110)		PROPOSED CATCHBASIN
	DIRECTION OF MAJOR SYSTEM OVERLAND FLOW		EXISTING CATCHBASIN MANHOLE
	FFE FINISHED FLOOR ELEVATION		PROPERTY LINE
	T/FND TOP OF FOUNDATION WALL ELEVATION		EXISTING EDGE OF PAVEMENT
	USF UNDERSIDE OF FOOTING ELEVATION		EXISTING VALVE & VALVE BOX
	PROPOSED MUD MAT / CONSTRUCTION ENTRANCE		EXISTING SERVICE POST
	ROOF DRAIN		EXISTING HYDRANT
	PROPOSED BARRIER CURB (PER SC1.1)		EXISTING CATCHBASIN
	PROPOSED DEPRESSED CURB (PER SC1.1)		EXISTING CATCHBASIN MANHOLE
	1.5 YEAR PONDING LIMIT		EXISTING UTILITY POLE
	1:100 YEAR PONDING LIMIT		

**GENERAL NOTES:**

1. COORDINATE AND SCHEDULE ALL WORK WITH OTHER TRADES AND CONTRACTORS.
2. DETERMINE THE EXACT LOCATION, SIZE, MATERIAL AND ELEVATION OF ALL EXISTING UTILITIES PRIOR TO COMMENCING CONSTRUCTION. PROTECT AND ASSUME RESPONSIBILITY FOR ALL EXISTING UTILITIES WHETHER OR NOT SHOWN ON THIS DRAWING.
3. OBTAIN ALL NECESSARY PERMITS AND APPROVALS FROM THE CITY OF OTTAWA BEFORE COMMENCING CONSTRUCTION.
4. BEFORE COMMENCING CONSTRUCTION OBTAIN AND PROVIDE PROOF OF COMPREHENSIVE, ALL RISK AND OPERATIONAL LIABILITY INSURANCE FOR \$5,000,000.00. INSURANCE POLICY TO NAME OWNERS, ENGINEERS AND ARCHITECTS AS CO-INSURED.
5. COMPLETE ALL WORKS IN ACCORDANCE WITH THE MOST CURRENT CITY OF OTTAWA STANDARDS AND SPECIFICATIONS USING THE CURRENT GUIDELINES, BYLAWS AND STANDARDS INCLUDING MATERIALS OF CONSTRUCTION, DIMENSIONS AND ALL RELEVANT REFERENCES TO OPSS, OPSD, & AWWA GUIDELINES - ALL CURRENT VERSIONS AND AS AMENDED.
6. RESTORE ALL DISTURBED AREAS ON-SITE AND OFF-SITE, INCLUDING TRENCHES AND SURFACES ON PUBLIC ROAD ALLOWANCES TO EXISTING CONDITIONS OR BETTER TO THE SATISFACTION OF THE CITY OF OTTAWA AND ENGINEER.
7. REMOVE FROM SITE ALL EXCESS EXCAVATED MATERIAL, ORGANIC MATERIAL AND DEBRIS UNLESS OTHERWISE INSTRUCTED BY ENGINEER. EXCAVATE AND REMOVE FROM SITE ANY CONTAMINATED MATERIAL. ALL CONTAMINATED MATERIAL SHALL BE DISPOSED OF AT A LICENSED LANDFILL FACILITY.
8. ALL ELEVATIONS ARE GEODETIC.
9. REFER TO GEOTECHNICAL REPORT (No. PG5736-1, DATED APRIL 23, 2021), PREPARED BY PATERSON GROUP FOR SUBSURFACE CONDITIONS, CONSTRUCTION RECOMMENDATIONS, AND GEOTECHNICAL INSPECTION REQUIREMENTS. THE GEOTECHNICAL CONSULTANT IS TO REVIEW ON-SITE CONDITIONS AFTER EXCAVATION PRIOR TO PLACEMENT OF THE GRANULAR MATERIAL.
10. REFER TO ARCHITECTS AND LANDSCAPE ARCHITECTS DRAWINGS FOR BUILDING AND HARDSURFACE AREAS AND DIMENSIONS.
11. REFER TO DEVELOPMENT SERVICING AND STORMWATER MANAGEMENT REPORT (R-2022-206) PREPARED BY NOVATECH ENGINEERING CONSULTANTS LTD.
12. SAW CUT AND KEY GRIND ASPHALT AT ALL ROAD CUTS AND ASPHALT TIE IN POINTS AS PER CITY OF OTTAWA STANDARDS (R10).
13. PROVIDE LINE/PARKING PAINTING.
14. CONTRACTOR TO PROVIDE THE CONSULTANT WITH A GENERAL PLAN OF SERVICES AND GRADING PLAN INDICATING ALL SERVICING AS-BUILT INFORMATION SHOWN ON THE PLANS. AS-BUILT INFORMATION MUST INCLUDE: PIPE MATERIALS, SIZES, LENGTHS, SLOPES, INVERT AND TIG ELEVATIONS, STRUCTURE LOCATIONS, VALVE AND HYDRANT LOCATIONS, T/W/M ELEVATIONS, ANY ALIGNMENT CHANGES, AND ALL SURFACE ELEVATION AS BUILT GRADES.

**GRADING NOTES:**

1. ALL TOPSOIL, ORGANIC OR DELETERIOUS MATERIAL MUST BE ENTIRELY REMOVED FROM BENEATH THE PROPOSED PAVED AREAS AS DIRECTED BY THE SITE ENGINEER OR GEOTECHNICAL ENGINEER.
2. EXPOSED SUBGRADES IN PROPOSED PAVED AREAS SHOULD BE PROOF ROLLED WITH A LARGE STEEL DRUM ROLLER AND INSPECTED BY THE GEOTECHNICAL ENGINEER PRIOR TO THE PLACEMENT OF GRANULARS.
3. ANY SOFT AREAS EVIDENT FROM THE PROOF ROLLING SHOULD BE SUB-EXCAVATED AND REPLACED WITH SUITABLE MATERIAL THAT IS FROST COMPATIBLE WITH THE EXISTING SOILS AS RECOMMENDED BY THE GEOTECHNICAL ENGINEER.
4. THE GRANULAR BASE SHOULD BE COMPACTED TO AT LEAST 100% OF THE STANDARD PROCTOR MAXIMUM DRY DENSITY VALUE. ANY ADDITIONAL GRANULAR FILL USED BELOW THE PROPOSED PAVEMENT SHOULD BE COMPACTED TO AT LEAST 95% OF THE STANDARD PROCTOR MAXIMUM DRY DENSITY VALUE.
5. MINIMUM OF 2% GRADE FOR ALL GRASS AREAS UNLESS OTHERWISE NOTED.
6. MAXIMUM TERRACING GRADE TO BE 3:1 UNLESS OTHERWISE NOTED.
7. ALL GRADES BY CURBS ARE EDGE OF PAVEMENT GRADES UNLESS OTHERWISE INDICATED.
8. ALL CURBS SHALL BE BARRIER CURB (150MM) UNLESS OTHERWISE NOTED AND CONSTRUCTED AS PER CITY OF OTTAWA STANDARDS (SC1.1).
9. REFER TO LANDSCAPE PLAN FOR PLANTING AND OTHER LANDSCAPE FEATURE DETAILS.
13. CONTRACTOR TO PROVIDE THE CONSULTANT WITH A GRADING PLAN INDICATING AS-BUILT ELEVATIONS OF ALL DESIGN GRADES SHOWN ON THIS PLAN.

**PAVEMENT STRUCTURE:**

	LIGHT DUTY 50mm HL3 OR SUPERPAVE 12.5 ASPHALTIC CONCRETE 150mm OPSS GRAN 'A' CRUSHED STONE 300mm OPSS GRAN 'B' TYPE II
	HEAVY DUTY 40mm SUPERPAVE 12.5 ASPHALTIC CONCRETE 50mm SUPERPAVE 19.0 ASPHALTIC CONCRETE 150mm OPSS GRAN 'A' CRUSHED STONE 400mm OPSS GRAN 'B' TYPE II

**Erosion and Sediment Control Responsibilities:**

ESC Measure	Symbol	Specification	Installation Responsibility	During Construction		After Construction Prior to Final Acceptance		After Final Acceptance	
				Inspector/Maintenance Responsibility	Inspection Frequency	Approval to Remove	Removal Responsibility	Inspection/Maintenance Responsibility	
Silt Fence		OPSD 219.110	Developer's Contractor	Developer's Contractor	Weekly (as a minimum)	Consultant	Developer's Contractor	N/A	
Filter Fabric		Location as Indicated On Plans	Developer's Contractor	Developer's Contractor	Weekly (as a minimum)	Consultant	Developer's Contractor	N/A	
Mud Mat		Drawing Details	Developer's Contractor	Developer's Contractor	Weekly (as a minimum)	Developer's Contractor	Developer's Contractor	N/A	
Dust Control		Location as Required Around Site	Developer's Contractor	Developer's Contractor	Weekly (as a minimum)	Consultant	Developer's Contractor	N/A	
Stabilized Material Stockpiling		Location as Required by Contractor	Developer's Contractor	Developer's Contractor	Weekly (as a minimum)	Developer's Contractor	Developer's Contractor	N/A	
Sediment Basin (for flows being pumped out of excavations)		Location as Required by Contractor	Developer's Contractor	Developer's Contractor	After Every Rainstorm	Developer's Contractor	Developer's Contractor	N/A	

**NOTE:**  
THE POSITION OF ALL POLE LINES, CONDUITS, WATERMANS, SEWERS AND OTHER UNDERGROUND AND OVERGROUND UTILITIES AND STRUCTURES IS NOT NECESSARILY SHOWN ON THE CONTRACT DRAWINGS, AND WHERE SHOWN, THE ACCURACY OF THE POSITION OF SUCH UTILITIES AND STRUCTURES IS NOT GUARANTEED. BEFORE STARTING WORK, DETERMINE THE EXACT LOCATION OF ALL SUCH UTILITIES AND STRUCTURES AND ASSUME ALL LIABILITY FOR DAMAGE TO THEM.

**OWNER INFORMATION**  
LANDRIC HOMES  
63 MONTREAL ROAD EAST  
GATINEAU, QUEBEC, J8M 1K3  
NAME: ERIC DANIS  
PHONE: (819) 593-4805  
ericdanis@constructionlaverendrye.com

No.	REVISION	DATE	BY
1.	ISSUED FOR SITE PLAN APPLICATION	DEC 20/22	MS

**SCALE**

1:300

**FOR REVIEW ONLY**

DESIGN	LSC
CHECKED	MS
DRAWN	LSC
CHECKED	MS
APPROVED	MS

**NOVATECH**  
Engineers, Planners & Landscape Architects  
Suite 200, 240 Michael Cowpland Drive  
Ottawa, Ontario, Canada K2M 1P6  
Telephone: (613) 254-9643  
Facsimile: (613) 254-5867  
Website: www.novatech-eng.com

LOCATION  
CITY OF OTTAWA  
1765 MONTREAL ROAD

DRAWING NAME  
**GRADING AND EROSION & SEDIMENT CONTROL PLAN**

PROJECT No. 121060  
REV #1  
DRAWING No. 121060-GR

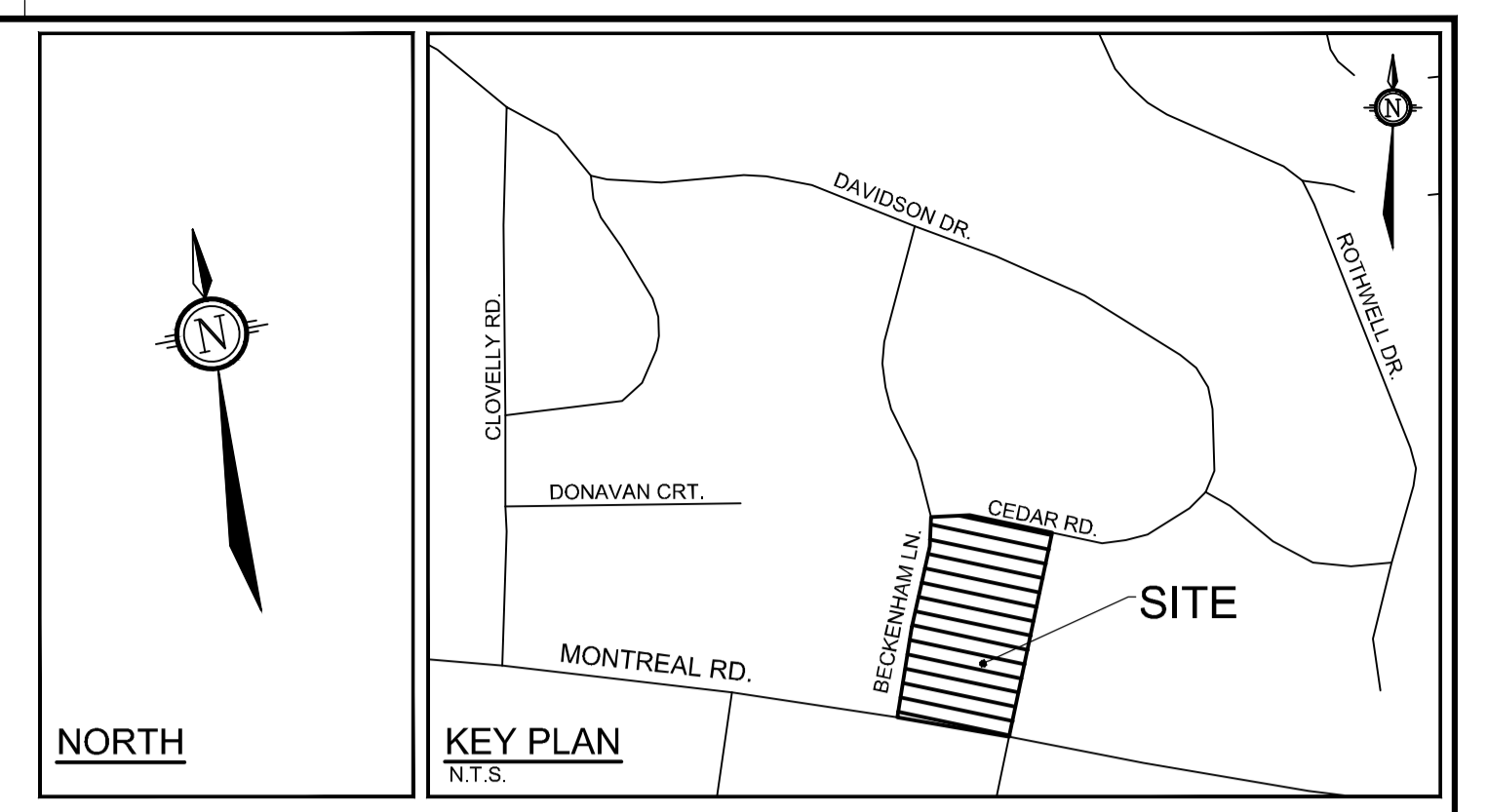
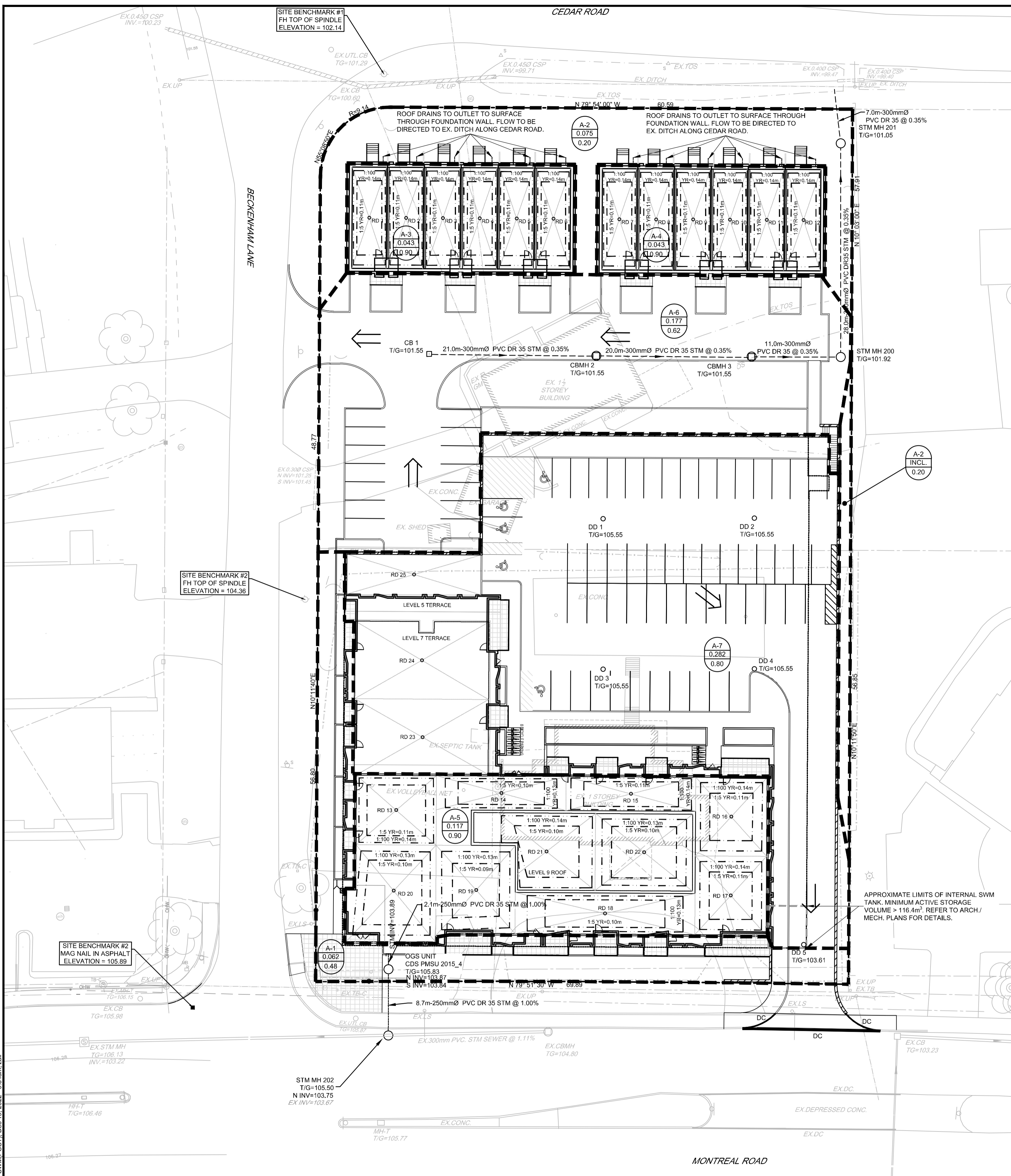

**LEGEND**

	DRAINAGE AREA LIMITS		PROPOSED RETAINING WALL
	POST-DEVELOPMENT AREA ID		PROPOSED STORM MANHOLE
	POST-DEVELOPMENT DRAINAGE AREA (ha)		PROPOSED CATCHBASIN
	1.5 YEAR WEIGHTED RUNOFF COEFFICIENT		PROPOSED CATCHBASIN MANHOLE
	1.5 YEAR PONDING LIMIT		PROPERTY LINE
	1:100 YEAR PONDING LIMIT		EXISTING EDGE OF PAVEMENT
	ROOF DRAIN		EXISTING VALVE & VALVE BOX
	PROPOSED AREA DECK DRAIN		EXISTING SERVICE POST
	PROPOSED BARRIER CURB		EXISTING HYDRANT
	PROPOSED DEPRESSED CURB		EXISTING CATCHBASIN
			EXISTING CATCHBASIN MH
			EXISTING UTILITY POLE
			EXISTING STORM MH & SEWER

**ROOF DRAIN TABLE: AREA A-3 (ROOF DRAINS 1-6)**

AREA ID (RD)	ROOF DRAIN No. (WATTS MODEL)	WEIR SETTING	1.5 YEAR RELEASE RATE	APPROX. 5 YR PONDING DEPTH	1:100 YEAR RELEASE RATE	APPROX. 100 YR PONDING DEPTH
A-3	RD 1 (RD-100-A-ADJ)	CLOSED	0.32 L/s	11 cm	0.32 L/s	14 cm
A-3	RD 2 (RD-100-A-ADJ)	CLOSED	0.32 L/s	11 cm	0.32 L/s	14 cm
A-3	RD 3 (RD-100-A-ADJ)	CLOSED	0.32 L/s	11 cm	0.32 L/s	14 cm
A-3	RD 4 (RD-100-A-ADJ)	CLOSED	0.32 L/s	11 cm	0.32 L/s	14 cm
A-3	RD 5 (RD-100-A-ADJ)	CLOSED	0.32 L/s	11 cm	0.32 L/s	14 cm
A-3	RD 6 (RD-100-A-ADJ)	CLOSED	0.32 L/s	11 cm	0.32 L/s	14 cm
TOTAL			1.92 L/s	-	1.92 L/s	-

**ROOF DRAIN TABLE: AREA A-4 (ROOF DRAINS 7-12)**

AREA ID (RD)	ROOF DRAIN No. (WATTS MODEL)	WEIR SETTING	1.5 YEAR RELEASE RATE	APPROX. 5 YR PONDING DEPTH	1:100 YEAR RELEASE RATE	APPROX. 100 YR PONDING DEPTH
A-4	RD 7 (RD-100-A-ADJ)	CLOSED	0.32 L/s	11 cm	0.32 L/s	14 cm
A-4	RD 8 (RD-100-A-ADJ)	CLOSED	0.32 L/s	11 cm	0.32 L/s	14 cm
A-4	RD 9 (RD-100-A-ADJ)	CLOSED	0.32 L/s	11 cm	0.32 L/s	14 cm
A-4	RD 10 (RD-100-A-ADJ)	CLOSED	0.32 L/s	11 cm	0.32 L/s	14 cm
A-4	RD 11 (RD-100-A-ADJ)	CLOSED	0.32 L/s	11 cm	0.32 L/s	14 cm
A-4	RD 12 (RD-100-A-ADJ)	CLOSED	0.32 L/s	11 cm	0.32 L/s	14 cm
TOTAL			1.92 L/s	-	1.92 L/s	-

**ROOF DRAIN TABLE: AREA A-5 (ROOF DRAINS 13-22)**

AREA ID (RD)	ROOF DRAIN No. (WATTS MODEL)	WEIR SETTING	1.5 YEAR RELEASE RATE	APPROX. 5 YR PONDING DEPTH	1:100 YEAR RELEASE RATE	APPROX. 100 YR PONDING DEPTH
A-5	RD 13 (RD-100-A-ADJ)	CLOSED	0.32 L/s	11 cm	0.32 L/s	14 cm
A-5	RD 14 (RD-100-A-ADJ)	1/4 EXPOSED	0.79 L/s	10 cm	0.87 L/s	13 cm
A-5	RD 15 (RD-100-A-ADJ)	CLOSED	0.32 L/s	11 cm	0.32 L/s	14 cm
A-5	RD 16 (RD-100-A-ADJ)	CLOSED	0.32 L/s	11 cm	0.32 L/s	14 cm
A-5	RD 17 (RD-100-A-ADJ)	CLOSED	0.32 L/s	11 cm	0.32 L/s	14 cm
A-5	RD 18 (RD-100-A-ADJ)	1/4 EXPOSED	0.79 L/s	10 cm	0.87 L/s	13 cm
A-5	RD 19 (RD-100-A-ADJ)	1/4 EXPOSED	0.75 L/s	9 cm	0.87 L/s	13 cm
A-5	RD 20 (RD-100-A-ADJ)	1/4 EXPOSED	0.79 L/s	10 cm	0.87 L/s	13 cm
A-5	RD 21 (RD-100-A-ADJ)	1/4 EXPOSED	0.79 L/s	10 cm	0.91 L/s	14 cm
A-5	RD 22 (RD-100-A-ADJ)	1/4 EXPOSED	0.79 L/s	10 cm	0.87 L/s	13 cm
TOTAL			5.98 L/s	-	6.54 L/s	-

\* REFER TO THE 'DEVELOPMENT SERVICING STUDY AND STORMWATER MANAGEMENT REPORT' (R-2022-206) PREPARED BY NOVATECH FOR DRAINAGE AREA IDENTIFIERS AND STORMWATER MANAGEMENT DETAILS.  
 \*\* ALL CONTROLLED FLOW ROOF DRAINS FOR THE PROPOSED BUILDING TO BE WATTS 'ADJUSTABLE ACCUTROL' ROOF DRAINS.

**INTERNAL SWM STORAGE SYSTEM**

DESIGN EVENT	STORAGE SYSTEM CONTROLLED FLOW	STORAGE VOLUMES REQUIRED	STORAGE VOLUMES PROVIDED
1:2 YR	15.1 L/s	21.4 m³	> 116.4 m³
1:5 YR	15.1 L/s	34.9 m³	
1:100 YR	15.1 L/s	90.4 m³	
1:100-20% 1:100-20%	15.1 L/s	116.4 m³	

- NOTES:**
- ALL DRAINAGE FROM AREA A-7 (PROPOSED PARKING LOT, DRIVEWAY DECK DRAINS 1-5, AND ROOF DRAINS 23-25) TO BE DIRECTED TO THE INTERNAL STORMWATER STORAGE TANK. REFER TO ARCHITECTURAL AND MECHANICAL PLANS FOR DETAILS.
  - DRAINAGE FROM AREA A-5 (RD 13-22) TO BE CONNECTED DIRECTLY TO GRAVITY STORM SERVICE BY-PASSING STORMWATER STORAGE TANK.
  - REFER TO ARCHITECTURAL AND STRUCTURAL PLANS FOR EXACT SIZE AND DETAILS OF INTERNAL STORMWATER STORAGE TANK.
  - REFER TO MECHANICAL PLANS FOR PUMP INFORMATION AND DETAILS.

**NOTE:**  
 THE POSITION OF ALL POLE LINES, CONDUITS, WATERMANS, SEWERS AND OTHER UNDERGROUND AND OVERGROUND UTILITIES AND STRUCTURES IS NOT NECESSARILY SHOWN ON THE CONTRACT DRAWINGS, AND WHERE SHOWN, THE ACCURACY OF THE POSITION OF SUCH UTILITIES AND STRUCTURES IS NOT GUARANTEED. BEFORE STARTING WORK, DETERMINE THE EXACT LOCATION OF ALL SUCH UTILITIES AND STRUCTURES AND ASSUME ALL LIABILITY FOR DAMAGE TO THEM.

**OWNER INFORMATION**  
 LANDRIC HOMES  
 63 MONTREAL ROAD EAST  
 GATINEAU, QUEBEC, J8M 1K3  
 NAME: ERIC DANIS  
 PHONE: (819) 593-4805  
 ericdanis@constructionlaverendrye.com

No.	REVISION	DATE	BY
1.	ISSUED FOR SITE PLAN APPLICATION	DEC 20/22	MS

**SCALE**

1:300

**FOR REVIEW ONLY**

DESIGN	ZA
CHECKED	MS
DRAWN	ZA
CHECKED	MS
APPROVED	MS



**NOVATECH**  
 Engineers, Planners & Landscape Architects  
 Suite 200, 240 Michael Cowpland Drive  
 Ottawa, Ontario, Canada K2M 1P6  
 Telephone: (613) 254-9643  
 Facsimile: (613) 254-5867  
 Website: www.novatech-eng.com

**LOCATION**  
 CITY OF OTTAWA  
 1765 MONTREAL ROAD

**DRAWING NAME**  
 STORMWATER  
 MANAGEMENT PLAN

**PROJECT No.** 121060  
**REV # 1**  
**DRAWING No.** 121060-SWM

M:\2022\121060\CAD\Design\121060-SWM.dwg, SWM(FPOST), Dec 19, 2022, 9:54am, zali





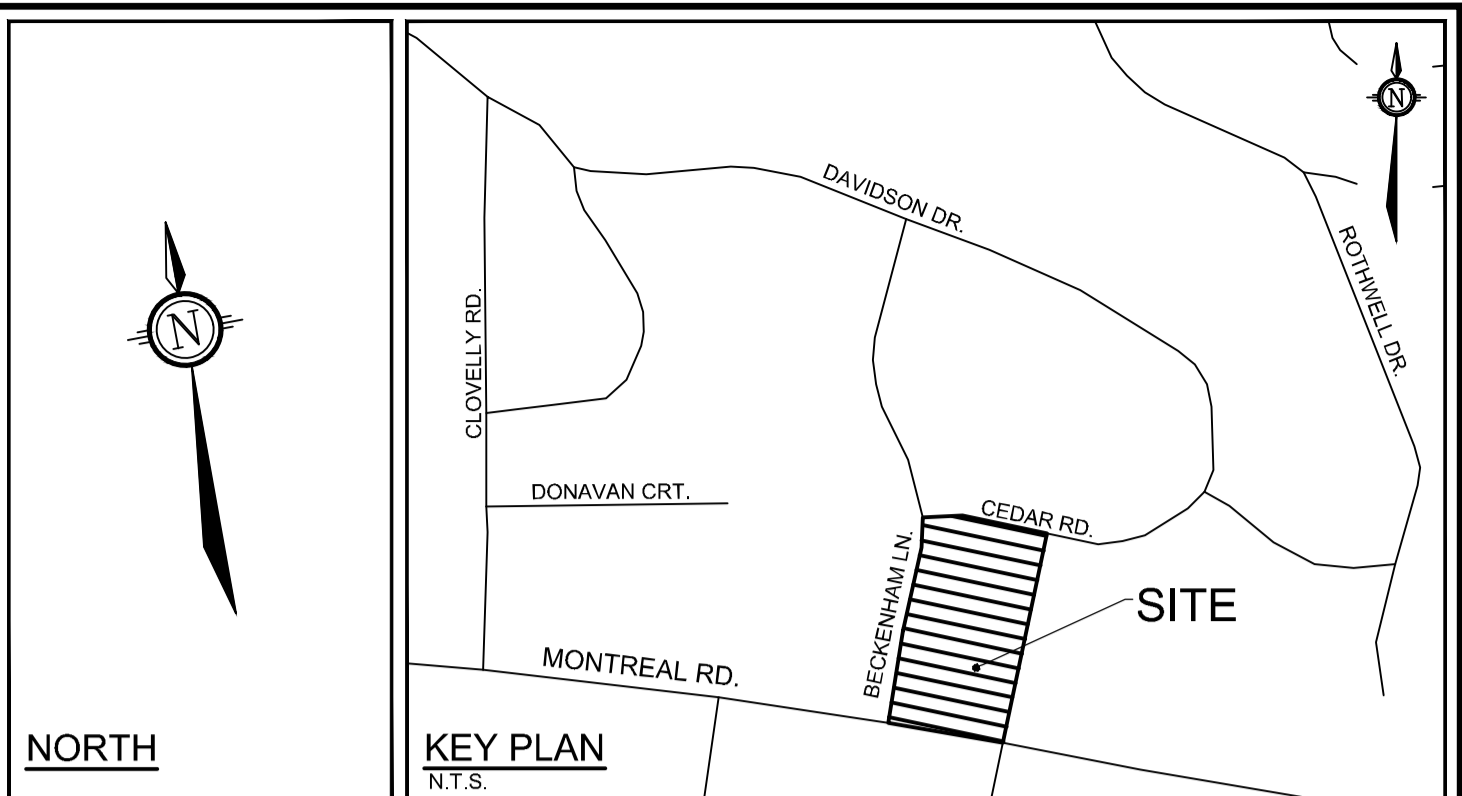
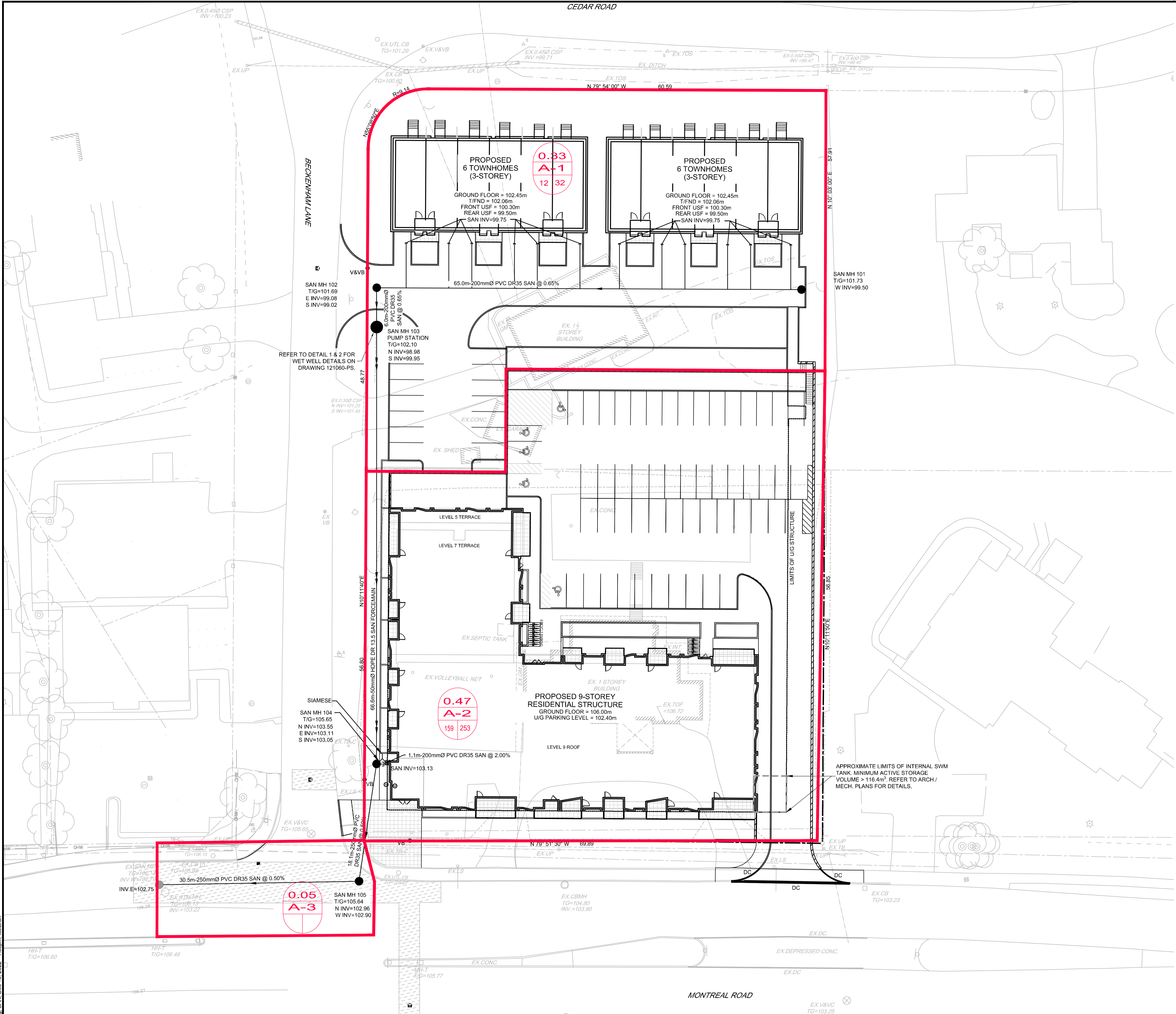

**LEGEND**

— DRAINAGE AREA LIMITS

0.19 HECTARES  
A-2 DRAINAGE AREA NUMBER  
11 31 POPULATION

**NOTE:**  
THE POSITION OF ALL POLE LINES, CONDUITS, WATERMANS, SEWERS AND OTHER UNDERGROUND AND OVERGROUND UTILITIES AND STRUCTURES IS NOT NECESSARILY SHOWN ON THE CONTRACT DRAWINGS, AND WHERE SHOWN, THE ACCURACY OF THE POSITION OF SUCH UTILITIES AND STRUCTURES IS NOT GUARANTEED. BEFORE STARTING WORK, DETERMINE THE EXACT LOCATION OF ALL SUCH UTILITIES AND STRUCTURES AND ASSUME ALL LIABILITY FOR DAMAGE TO THEM.

**OWNER INFORMATION**  
LANDRIC HOMES  
63 MONTREAL ROAD EAST  
GATINEAU, QUEBEC, J8M 1K3  
NAME: ERIC DANIS  
PHONE: (819) 593-4805  
ericdanis@constructionlaverendrye.com

No.	REVISION	DATE	BY
1.	ISSUED FOR SITE PLAN APPLICATION	DEC 20/22	MS

**SCALE**

1:300

DESIGN	DESIGN
LSC	CHECKED
MS	DRAWN
LSC	CHECKED
MS	APPROVED

**FOR REVIEW ONLY**

**NOVATECH**  
Engineers, Planners & Landscape Architects  
Suite 200, 240 Michael Cowpland Drive  
Ottawa, Ontario, Canada K2M 1P6  
Telephone: (613) 254-9643  
Facsimile: (613) 254-5867  
Website: www.novatech-eng.com

**LOCATION**  
CITY OF OTTAWA  
1765 MONTREAL ROAD

**DRAWING NAME**  
SANITARY DRAINAGE AREA PLAN

PROJECT No. 121060  
REV # 1  
DRAWING No. 121060-SAN

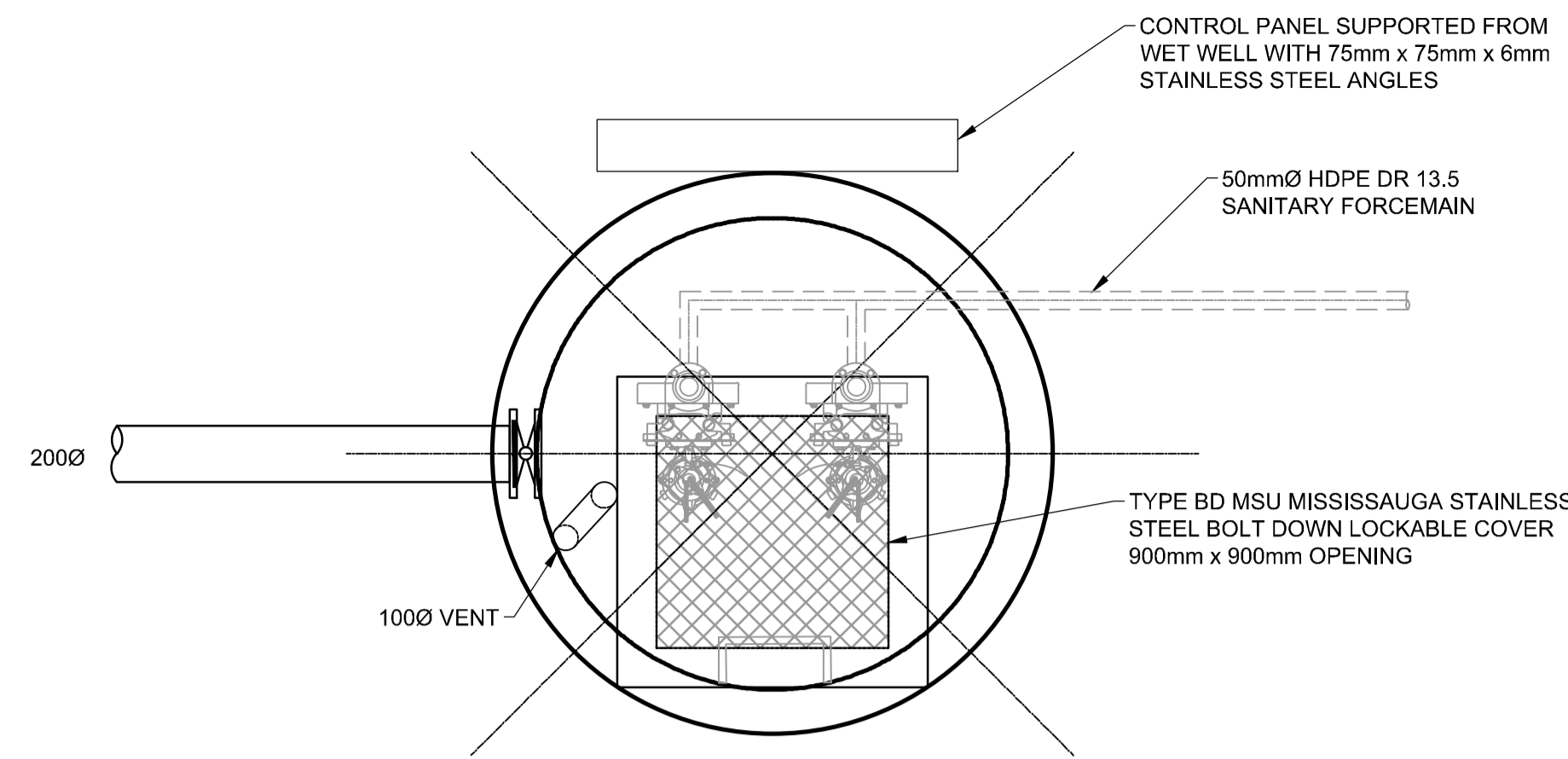

1 WET WELL - PLAN  
SCALE = 1:25

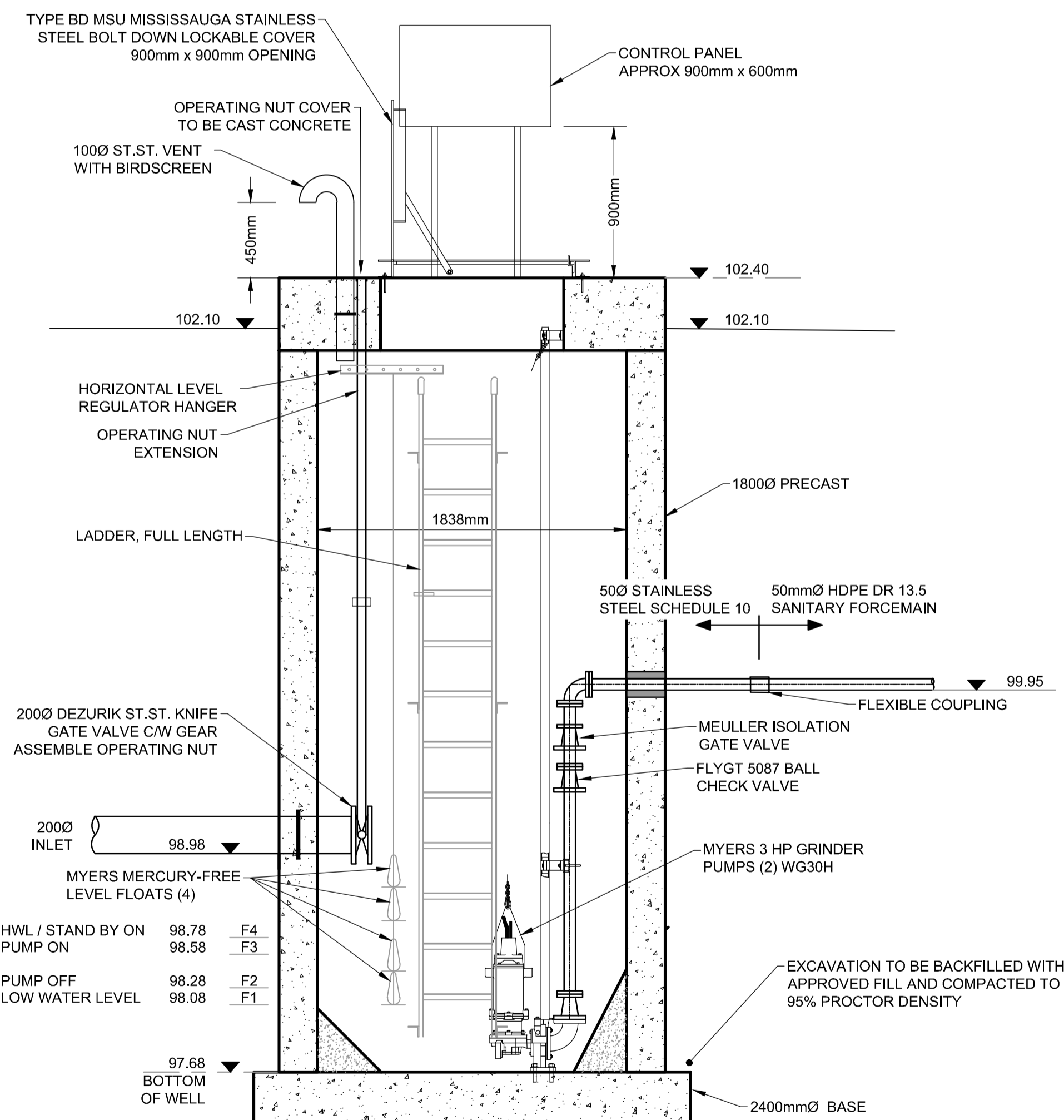
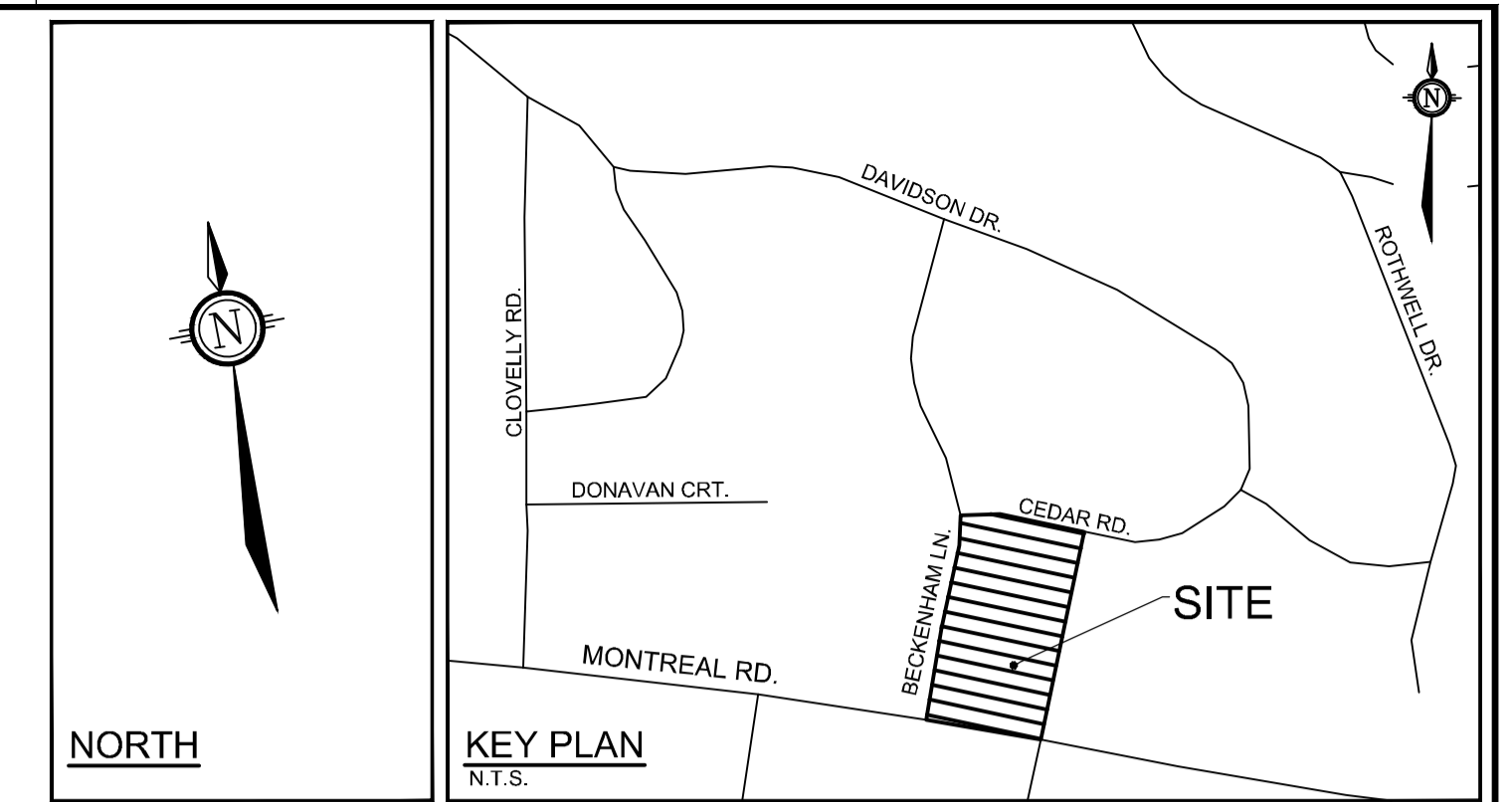

2 WET WELL - SECTION  
SCALE = 1:25

- TWO MYERS WG30-53, 3 HP PUMPS, 575 V COMPLETE WITH PUMP RAILS, GALVANIZED CHAIN AND COMPONENTS FOR LIFT OUT FROM SURFACE INCLUDING DISCHARGE ELBOW RATED FOR 1.0 L/s @ 10m TDH. PROVIDE MYERS CONTROL PANEL INCLUDING THE FOLLOWING:
- GENERAL ALARM FLASHING LIGHT ON TOP PANEL
  - LOCKABLE OUTER DOOR - MAIN PANEL DISCONNECT
  - AUTO/OFF/HAND SELECTOR SWITCH FOR EACH PUMP
  - PUMP ON & PUMP FAULT INDICATION LIGHTS
  - COMBINATION MOTOR STARTERS
  - GENERAL ALARM DRY CONTACT
  - STEEL OUTDOOR RATED ENCLOSURE
  - PANEL SUPPORTED FROM WET WELL WITH TWO 100x100 STAINLESS STEEL ANGLES
  - ANTICONDENSATE HEATER
  - ALTERNATE PUMPS ON EACH CYCLE
  - HOUR METERS FOR EACH PUMP
  - DUTY PUMP ON WHEN LEVEL REACHES 98.58m. STANDBY PUMP STARTS AT HIGH WATER LEVEL
  - GENERAL ALARM FOR PUMP FAULTS INCLUDING OVERLOAD OR LEAK DETECTION
  - ALL CONNECTIONS/COMPONENTS STAINLESS STEEL UNLESS NOTED OTHERWISE

M:\2021\121060\CAD\Design\121060-PS.dwg, PS, Dec 19, 2022 - 12:18pm, kashban

NOTE:  
THE POSITION OF ALL POLE LINES, CONDUITS, WATERMANS, SEWERS AND OTHER UNDERGROUND AND OVERGROUND UTILITIES AND STRUCTURES IS NOT NECESSARILY SHOWN ON THE CONTRACT DRAWINGS, AND WHERE SHOWN, THE ACCURACY OF THE POSITION OF SUCH UTILITIES AND STRUCTURES IS NOT GUARANTEED. BEFORE STARTING WORK, DETERMINE THE EXACT LOCATION OF ALL SUCH UTILITIES AND STRUCTURES AND ASSUME ALL LIABILITY FOR DAMAGE TO THEM.

No.	REVISION	DATE	BY
1.	ISSUED FOR SITE PLAN APPLICATION	DEC 2022	CJS

SCALE	DESIGN	CHECKED	DRAWN	CHECKED	APPROVED
AS NOTED	CJS	CJS	LSC	CJS	CJS

**FOR REVIEW ONLY**

**NOVATECH**  
Engineers, Planners & Landscape Architects  
Suite 200, 240 Michael Cowpland Drive  
Ottawa, Ontario, Canada K2M 1P6  
Telephone: (613) 254-9643  
Facsimile: (613) 254-5867  
Website: www.novatech-eng.com

LOCATION CITY OF OTTAWA 1765 MONTREAL ROAD		PROJECT No. 121060
DRAWING NAME PUMP STATION WET WELL DETAILS		REV # 1
		DRAWING No. 121060-PS