



000_ENG_DRAWING LIST				
No	Title	Revision	Date	Current Revision Description
A000	TITLE DRAWING LIST	5	2023-09-15	ISSUED FOR SPA R4
A002	CONTEXT PLAN	2	2023-03-30	ISSUED FOR SPA R1
A100	SITE PLAN	5	2023-09-15	ISSUED FOR SPA R4
A101	ENLARGED SITE PLAN 1/4	5	2023-09-15	ISSUED FOR SPA R4
A102	ENLARGED SITE PLAN 2/4	5	2023-09-15	ISSUED FOR SPA R4
A103	ENLARGED SITE PLAN 3/4	5	2023-09-15	ISSUED FOR SPA R4
A104	ENLARGED SITE PLAN 4/4	5	2023-09-15	ISSUED FOR SPA R4
A110	SITE DETAILS	2	2023-03-30	ISSUED FOR SPA R1
A111	SITE DETAILS	2	2023-03-30	ISSUED FOR SPA R1

REV. ISSUED FOR SPA R4

ROSEFELLOW.



All Hamlin

APPROVED
By Allison Hamlin at 2:57 pm, Oct 13, 2023

ALLISON HAMLIN
MANAGER (A), DEVELOPMENT REVIEW WEST
PLANNING, REAL ESTATE & ECONOMIC DEVELOPMENT
DEPARTMENT, CITY OF OTTAWA

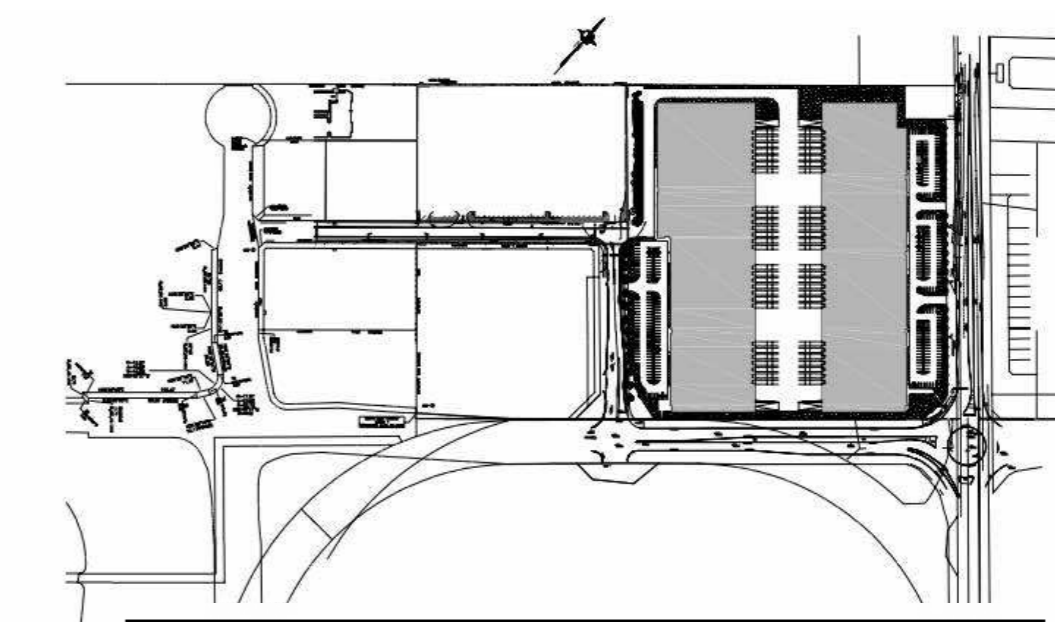
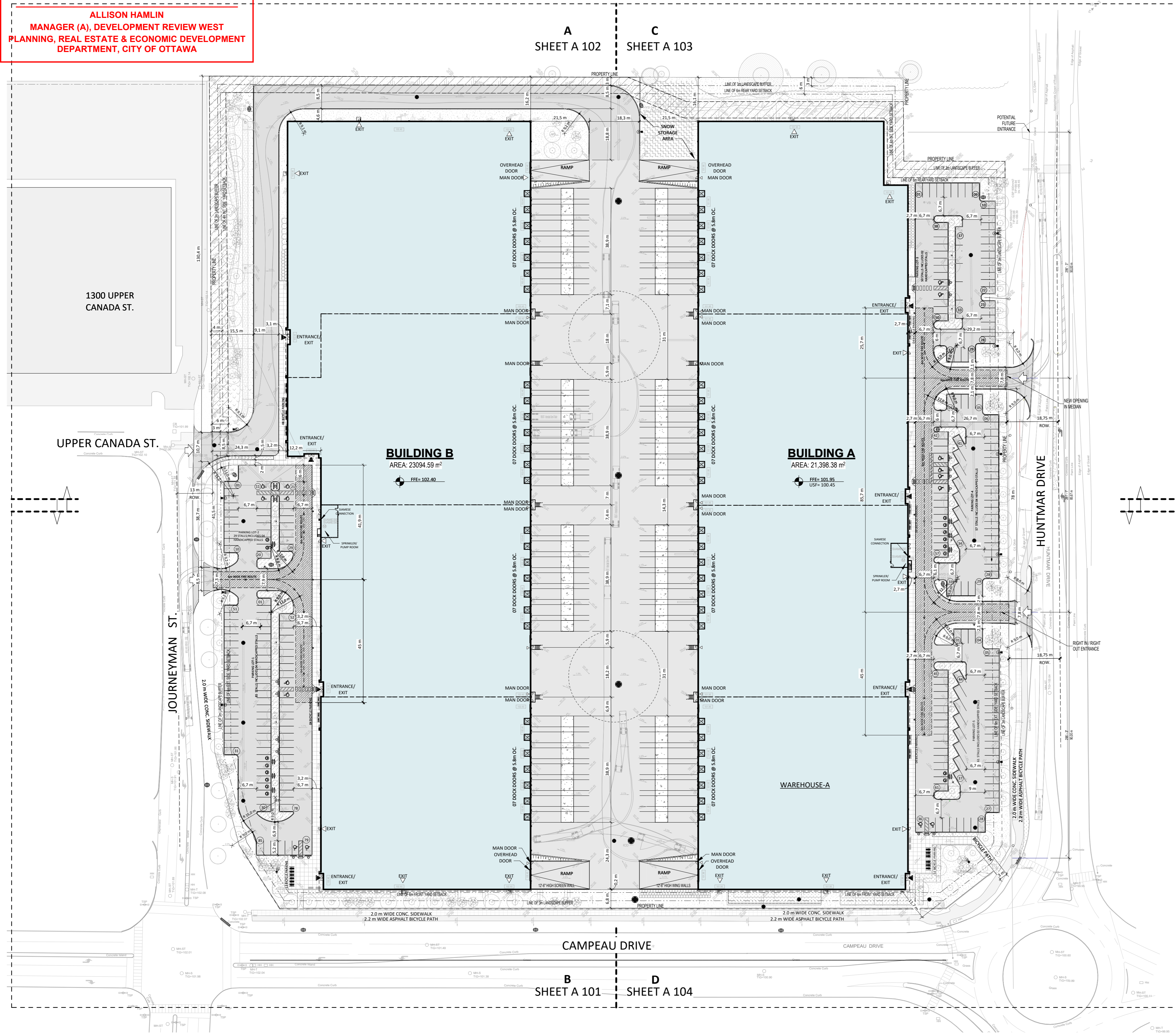

PROJECT STATISTICS

PROPERTY

PART OF LOT 4
CONCESSION 1
GEOGRAPHIC TOWNSHIP OF HUNTELY
CITY OF OTTAWA, ON.

ADDRESS: 405 HUNTMAR DR
LOT AREA: #21.4 ac #932,756 ft² #86,687.4 m²

SETBACKS	ALLOWED/REQUIRED	PROPOSED
- FRONT YARD	6m	7.1m
- EXTERIOR SIDE YARD	6m	27.5m
- INTERIOR SIDE YARD	4m	7.2m
- REAR YARD	6m	8.7m

- MAX. FSI	2	0.5
- MAX G.F.A	173,374.8 m ²	444,493 m ²
- COVERAGE	55%	51%
- BUILDING HEIGHT	22m	11.2m
- LANDSCAPE REQUIREMENT	15%	15%

CITY PARKING REQUIREMENTS

- LIGHT INDUSTRIAL	0.8/100 m ² FOR THE FIRST 5,000 m ² AND 0.4/100 m ² ABOVE 5,000 m ²	
- HC RESERVED		
- MIN. ASLE WIDTH	6.7m	
- LANDSCAPED BUFFER TO STREET	MIN. 3m	
- STANDARD STALL DIMENSIONS	MIN. 2.6m X 5.2m	
- HC STALL DIMENSIONS	MAX. 3.66m X 5.2m	
- BICYCLE PARKING	1/1,000m ²	

PROPOSED BUILDING AREAS		
- BUILDING A	#230,247 ft ²	#21,398 m ²
- BUILDING B	#248,498 ft ²	#23,095 m ²
- TOTAL GROSS FLOOR AREA (G.F.A.)	#478,744 ft ²	#44,493 m ²
- TOTAL COVERAGE		#51.5%
- TOTAL LANDSCAPING	#138,512 ft ²	15%

PROPOSED PARKING

BUILDING A

- PARKING REQUIRED BY THE CITY: 106 STALLS
- PARKING PROVIDED: 168 STALLS
- BICYCLE PARKING REQUIRED: 22 STALLS

BUILDING B

- PARKING REQUIRED BY THE CITY: 114 STALLS
- PARKING PROVIDED: 114 STALLS
- BICYCLE PARKING REQUIRED: 24 STALLS

GKC

ARCHITECTURE & DESIGN

MONTREAL - TORONTO
100 - 7275 ST-URBAIN MONTREAL QC H2R 2Y5 T5154.737.6255 WWW.GKC.CA

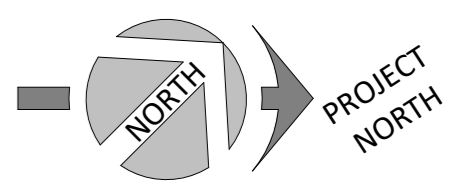
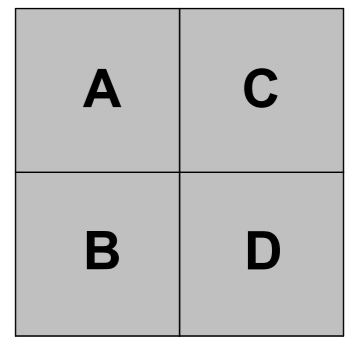

SURVEY:
ALL THE INFORMATION RELATED TO THE SITE ARE ON THE PLAN PREPARED BY: "COMPANY NAME HERE"

DRAWING: NO X
FOUN: XX
MINUTE: XX
DATE: YYYY-MM-DD

LOCATION:
THIS BUILDING IS PARALLEL TO THE SOUTHERN PROPERTY LINE. GOVERNING DIMENSIONS ARE FROM PROPERTY LINE TO STRUCTURAL GRIDLINE.

PUBLIC UTILITY SERVICES:
ALL POINTS OF CONNECTION SHOWN ARE CONCEPTUAL AND MAY BE MODIFIED ACCORDING TO THE NEEDS AND REQUIREMENTS OF THE PUBLIC AUTHORITIES CONCERNED (SEWERS, AQUEDUCT, DISTRIBUTION OF NATURAL GAS AND ELECTRICITY, TELEPHONE SERVICE AND CABLE DISTRIBUTION). SITE CONDITIONS, NEEDS AND SUBCONTRACTORS COORDINATION. ANY MODIFICATION ARE THE SOLE RESPONSIBILITY OF THE CONTRACTOR AND SHALL BE SUBMITTED TO THE ARCHITECT FOR EXAMINATION AND COORDINATION BEFORE EXECUTION.

DIMENSIONS:
ALL BUILDING DIMENSIONS ARE TAKEN FROM THE EXTERIOR FACE OF THE WALLS AT 1'-0" ABOVE THE GROUND FLOOR.

FIRE PROTECTION:
ALL FLOOR AREAS OF THIS BUILDING WILL BE PROTECTED BY AN AUTOMATIC SPRINKLER SYSTEM IN ACCORDANCE WITH THE REQUIREMENTS OF THE NATIONAL BUILDING CODE AND INSURER REQUIREMENTS.

CIVIL:
CONSULT CIVIL ENGINEER'S DRAWINGS FOR: SITE LEVELS, DRAINAGE SLOPES, RETENTION BASINS, MANHOLES, CATCH BASINS, AND ALL UNDERGROUND SERVICES.

SOIL REPORT:
SOIL TESTING, CORE SAMPLING AND CARRYING CAPACITY. CONSULT THE SOIL REPORT PREPARED BY: REPORT NO: XX
DATE: XX

BUILDING A AREA SUMMARY	
TENANT BUILDING A1	
- WAREHOUSE	#55,410 ft ² #5,150 m ²
- OFFICE (5%)	#2,916 ft ² #271 m ²
- A1 TENANT AREA	#58,326 ft ² #5,421 m ²
TENANT BUILDING A2	
- WAREHOUSE	#55,074 ft ² #5,118 m ²
- OFFICE (5%)	#2,899 ft ² #269 m ²
- A2 TENANT AREA	#57,972 ft ² #5,388 m ²
TENANT BUILDING A3	
- WAREHOUSE	#54,980 ft ² #5,110 m ²
- OFFICE (5%)	#2,894 ft ² #269 m ²
- A3 TENANT AREA	#57,874 ft ² #5,379 m ²
TENANT BUILDING A4	
- WAREHOUSE	#53,271 ft ² #4,951 m ²
- OFFICE (5%)	#2,804 ft ² #261 m ²
- A4 TENANT AREA	#56,074 ft ² #5,211 m ²
TOTAL AREA BUILDING A	#230,247 ft² #21,398 m²
BUILDING B AREA SUMMARY	
TENANT BUILDING B1	
- WAREHOUSE	#55,352 ft ² #5,142 m ²
- OFFICE (5%)	#2,913 ft ² #271 m ²
- B1 TENANT AREA	#58,265 ft ² #5,415 m ²
TENANT BUILDING B2	
- WAREHOUSE	#55,098 ft ² #5,112 m ²
- OFFICE (5%)	#2,896 ft ² #269 m ²
- B2 TENANT AREA	#57,924 ft ² #5,383 m ²
TENANT BUILDING B3	
- WAREHOUSE	#58,870 ft ² #5,469 m ²
- OFFICE (5%)	#3,098 ft ² #288 m ²
- B3 TENANT AREA	#61,968 ft ² #5,759 m ²
TENANT BUILDING B4	
- WAREHOUSE	#66,823 ft ² #6,208 m ²
- OFFICE (5%)	#3,517 ft ² #327 m ²
- B4 TENANT AREA	#70,340 ft ² #6,537 m ²
TOTAL AREA BUILDING B	#248,498 ft² #23,095 m²

LEGEND (OVERALL PLAN)

- PROPERTY LINE
- SETBACK LINE (YARD & BUFFER)
- FIRE ROUTE
- PROPOSED NEW BUILDING
- PROPOSED LANDSCAPE AREA
- SITE ENTRANCE/EXIT
- BUILDING ENTRANCE/EXIT
- EXIT DOOR
- WATERMAIN EASEMENT, SEE CIVIL

SURVEY NOTES:
LEGAL SURVEY, TOPO AND PROPERTY LINES PROVIDED BY ANIS, O'SULLIVAN, VOLLEBEKK LTD. ON SEPTEMBER 27, 2021
PART OF LOT 4
CONCESSION 1
GEOGRAPHIC TOWNSHIP OF HUNTELY
CITY OF OTTAWA, ON.

SPA SITE PLAN 1
1:750 A100

ROSEFELLOW KANATA
405 HUNTMAR DR.
CITY OF OTTAWA ONTARIO



Copyright GKC Architects. Not to be used for any other project without the architect's written consent. All dimensions and conditions must be verified on site. Do not scale drawings. Any discrepancies or omissions in the drawing shall be reported to the architect immediately in writing. All work to conform to most recent applicable norms, bylaws and codes for all given trades.

ARCHITECTURE

SITE PLAN

DRAWN BY: AH CHECKED BY: EB
FILE NUMBER: D07-12-22-0186
TRANS NUMBER: 18906
SCALE: As indicated
FOLD: 22081 **A100 R5**

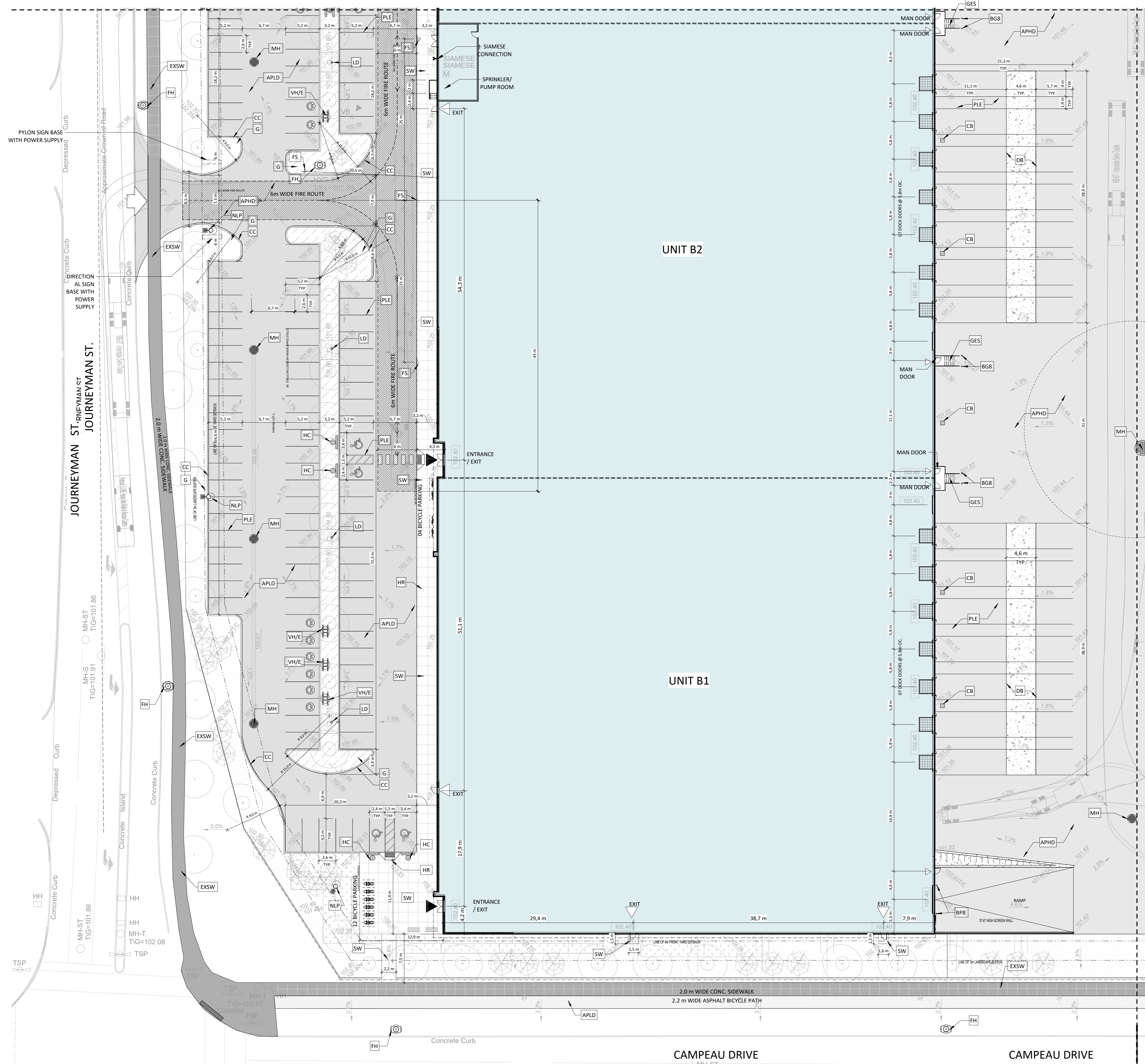

SYMBOLS LEGEND - SITE

- DETAIL**
- NEW BUILDINGS
 - APHD ASPHALT PAVING, HEAVY DUTY, SEE CIVIL
 - APLD ASPHALT PAVING, LIGHT DUTY, SEE CIVIL
 - EXTERIOR CONCRETE CURB, SEE CIVIL
 - GRASS OR OTHER LANDSCAPING, SEE LANDSCAPE
 - EXTERIOR CONCRETE BASE, SEE STRUCTURE FOR DETAILS
 - NEW LIGHT POLE REFER TO ELECTRICAL
 - EXISTING SIDEWALK
 - CONCRETE SIDEWALK, SEE CIVIL
 - HANDICAP PARKING SIGN
 - YELLOW PAINTED LINE - EXTERIOR
 - GALVANIZED BOLLARD, 6"Ø x 5'-0" HT. OR 8"Ø x 5'-0" HT., FULL WITH CONCRETE, CLOSED END WITH GALVANIZED CAP, INSTALLED IN A CONCRETE SONOTUBE OF 20"Ø @ 5'-0" DEPTH, MIN.
 - YELLOW PAINTED BOLLARD, 6"Ø x 4'-0" HT. OR 8"Ø x 4'-0" HT., 1'-0" DEPTH, FULL WITH CONCRETE, CLOSED END WITH CAP.
 - GALVANIZED EXIT STAIR
 - HANDICAP RAMP; SEE SPECIFICATIONS / CIVIL ENGINEERING PLAN RAMP SLOPE: 1:10-1:12
 - CHARGER FOR ELECTRIC/HYBRID VEHICLES (DOUBLE). PROVIDE 100mm HIGH CONCRETE BASE, WHEN NOT POSITIONED ON A SIDEWALK. COORDINATE THE SIZE OF THE BASE WITH CHOSEN CHARGER MODEL, SEE SPEC. AND ELECTRICAL
 - FIRE HYDRANT
 - SIAMESE FIRE DEPT. CONNECTION, SEE CIVIL AND FIRE PROTECTION
 - MANHOLE. SEE CIVIL
 - SEE CIVIL
 - CATCH BASIN. SEE CIVIL
 - CONCRETE SLAB (DOLLY PAD)
 - FIRE ROUTE SIGNAGE
 - WATERMAIN EASEMENT, SEE CIVIL

A	C
B	D

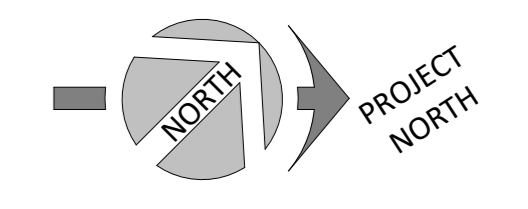

Allison Hamlin

ALLISON HAMLIN
 MANAGER (A), DEVELOPMENT REVIEW WEST
 PLANNING, REAL ESTATE & ECONOMIC DEVELOPMENT
 DEPARTMENT, CITY OF OTTAWA

APPROVED
 By Allison Hamlin at 2:57 pm, Oct 13, 2023

No.	Date	Revision	By
5	2023-09-15	ISSUED FOR SPA R4	SG
4	2023-08-04	ISSUED FOR SPA R3	SG
3	2023-05-30	ISSUED FOR SPA R2	
2	2023-03-30	ISSUED FOR SPA R1	
1	2022-12-16	ISSUED FOR SPA	

ROSEFELLOW KANATA
 405 HUNTMAR DR.
 CITY OF OTTAWA ONTARIO



Copyright GKC Architects. Not to be used for any other project without the architect's written consent. All dimensions and conditions must be verified on site. Do not scale drawings. Any discrepancies or omissions in the drawing shall be reported to the architect immediately in writing. All work to conform to most recent applicable norms, bylaws and codes for all given trades.

ARCHITECTURE
ENLARGED SITE PLAN 1/4

DRAWN BY: AH/AT CHECKED BY: AH/EB
 FILE NUMBER: **D07-12-22-0186**
 PLAN NUMBER: **18906**
 SCALE: As indicated
 FOLD: 22081 **A101 R5**

SPA ENLARGED SITE PLAN 1/4 1:300 **1** A101

A	C
B	D

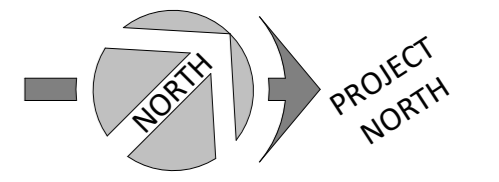

SYMBOLS LEGEND - SITE

DETAIL

- NEW BUILDINGS
- APHD ASPHALT PAVING, HEAVY DUTY, SEE CIVIL
- APLD ASPHALT PAVING, LIGHT DUTY, SEE CIVIL
- CC EXTERIOR CONCRETE CURB, SEE CIVIL
- G GRASS OR OTHER LANDSCAPING, SEE LANDSCAPE
- ECB EXTERIOR CONCRETE BASE, SEE STRUCTURE FOR DETAILS
- NLP NEW LIGHT POLE REFER TO ELECTRICAL
- EXSW EXISTING SIDEWALK
- SW CONCRETE SIDEWALK, SEE CIVIL
- HC HANDICAP PARKING SIGN
- PLE YELLOW PAINTED LINE - EXTERIOR
- GALVANIZED BOLLARD, 6"Ø x 5'-0" HT. OR 8"Ø x 5'-0" HT., FULL WITH CONCRETE, CLOSED END WITH GALVANIZED CAP, INSTALLED IN A CONCRETE SONOTUBE OF 20"Ø @ 5'-0" DEPTH, MIN.
- YELLOW PAINTED BOLLARD, 6"Ø x 4'-0" HT. OR 8"Ø x 4'-0" HT., 1'-0" DEPTH, FULL WITH CONCRETE, CLOSED END WITH CAP.
- GALVANIZED EXIT STAIR
- HANDICAP RAMP; SEE SPECIFICATIONS / CIVIL ENGINEERING PLAN RAMP SLOPE: 1:10-1:12
- CHARGER FOR ELECTRIC/HYBRID VEHICLES (DOUBLE). PROVIDE 100mm HIGH CONCRETE BASE, WHEN NOT POSITIONED ON A SIDEWALK. COORDINATE THE SIZE OF THE BASE WITH CHOSEN CHARGER MODEL, SEE SPEC. AND ELECTRICAL
- FIRE HYDRANT
- SIAMESE FIRE DEPT. CONNECTION, SEE CIVIL AND FIRE PROTECTION
- MANHOLE. SEE CIVIL
- LD SEE CIVIL
- CATCH BASIN. SEE CIVIL
- CONCRETE SLAB (DOLLY PAD)
- FIRE ROUTE SIGNAGE
- WATERMAIN EASEMENT, SEE CIVIL

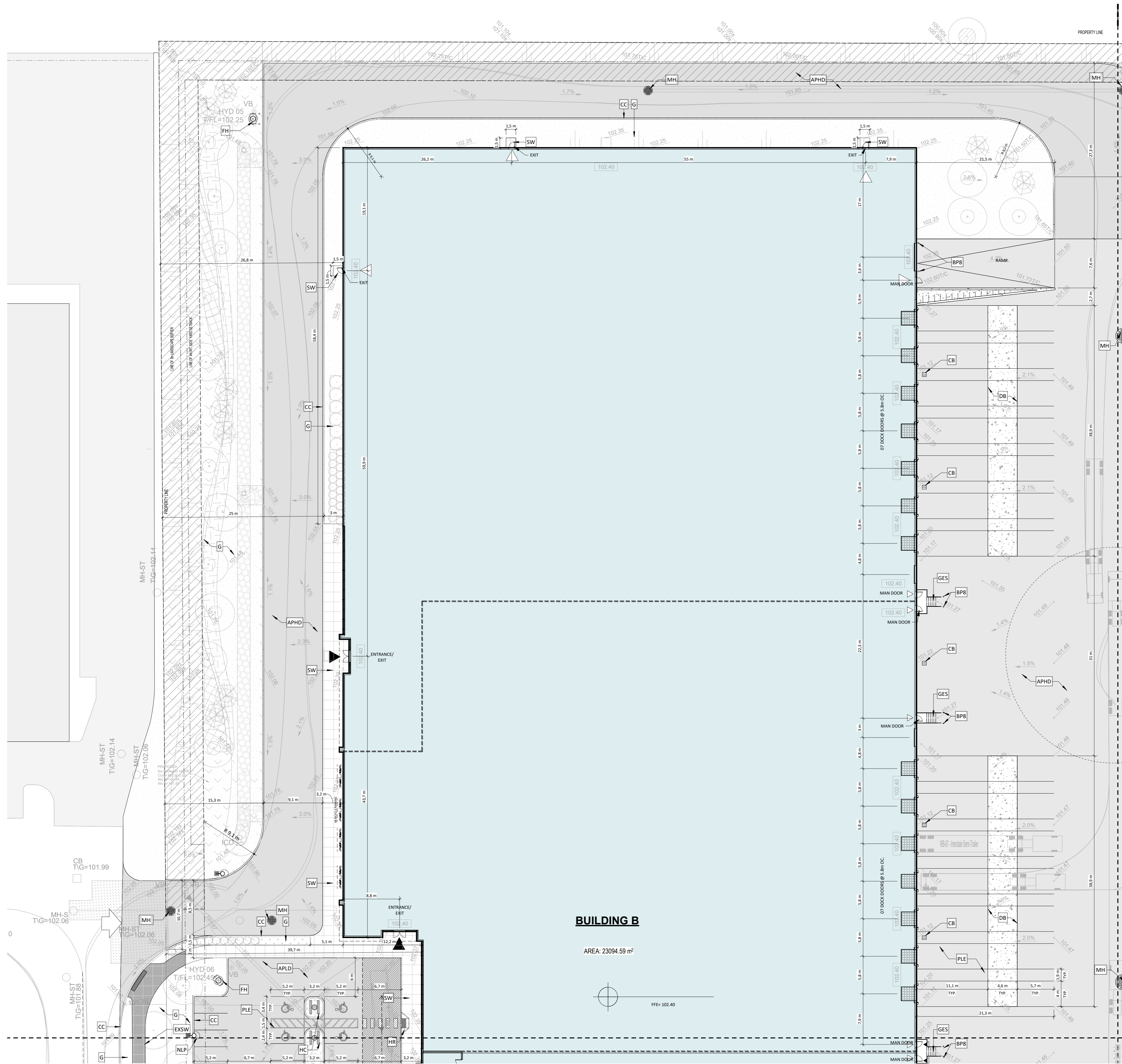

BUILDING B

AREA: 23094.59 m²

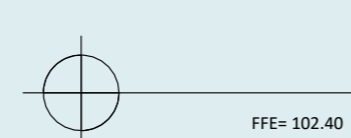

Alliamlin

ALLISON HAMLIN
MANAGER (A), DEVELOPMENT REVIEW WEST
PLANNING, REAL ESTATE & ECONOMIC DEVELOPMENT
DEPARTMENT, CITY OF OTTAWA

APPROVED
 By Allison Hamlin at 2:57 pm, Oct 13, 2023

SPA ENLARGED SITE PLAN 2/4
 1:300 A102

No.	Date	Revision	By
5	2023-09-15	ISSUED FOR SPA R4	SG
4	2023-08-04	ISSUED FOR SPA R3	SG
3	2023-05-30	ISSUED FOR SPA R2	
2	2023-03-30	ISSUED FOR SPA R1	
1	2022-12-16	ISSUED FOR SPA	

ROSEFELLOW KANATA
 405 HUNTMAR DR.
 CITY OF OTTAWA ONTARIO



Copyright GKC Architects. Not to be used for any other project without the architect's written consent. All dimensions and conditions must be verified on site. Do not scale drawings. Any discrepancies or omissions in the drawing shall be reported to the architect immediately in writing. All work to conform to most recent applicable norms, bylaws and codes for all given trades.

ARCHITECTURE

ENLARGED SITE PLAN 2/4

DRAWN BY: AT CHECKED BY: AH/EB
 FILE NUMBER: D07-12-22-0186
 SCALE: As indicated PLAN NUMBER: 18906
 FOLD: 22081 **A102 R5**

A	C
B	D

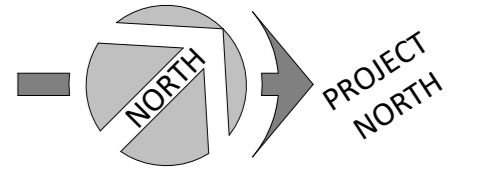

SYMBOLS LEGEND - SITE

DETAIL

- NEW BUILDINGS
- APHD ASPHALT PAVING, HEAVY DUTY, SEE CIVIL
- APLD ASPHALT PAVING, LIGHT DUTY, SEE CIVIL
- CC EXTERIOR CONCRETE CURB, SEE CIVIL
- G GRASS OR OTHER LANDSCAPING, SEE LANDSCAPE
- ECB EXTERIOR CONCRETE BASE, SEE STRUCTURE FOR DETAILS
- NLP NEW LIGHT POLE REFER TO ELECTRICAL
- EXSW EXISTING SIDEWALK
- SW CONCRETE SIDEWALK, SEE CIVIL
- HC HANDICAP PARKING SIGN
- PLE YELLOW PAINTED LINE - EXTERIOR
- GALVANIZED BOLLARD, 6"Ø x 5'-0" HT. OR 8"Ø x 5'-0" HT., FULL WITH CONCRETE, CLOSED END WITH GALVANIZED CAP, INSTALLED IN A CONCRETE SONOTUBE OF 20"Ø @ 5'-0" DEPTH, MIN.
- YELLOW PAINTED BOLLARD, 6"Ø x 4'-0" HT. OR 8"Ø x 4'-0" HT., 1'-0" DEPTH, FULL WITH CONCRETE, CLOSED END WITH CAP.
- GALVANIZED EXIT STAIR
- HANDICAP RAMP; SEE SPECIFICATIONS / CIVIL ENGINEERING PLAN RAMP SLOPE: 1:10-1:12
- CHARGER FOR ELECTRIC/HYBRID VEHICLES (DOUBLE). PROVIDE 100mm HIGH CONCRETE BASE, WHEN NOT POSITIONED ON A SIDEWALK. COORDINATE THE SIZE OF THE BASE WITH CHOSEN CHARGER MODEL, SEE SPEC. AND ELECTRICAL
- FIRE HYDRANT
- SIAMESE FIRE DEPT. CONNECTION, SEE CIVIL AND FIRE PROTECTION
- MANHOLE. SEE CIVIL
- SEE CIVIL
- CATCH BASIN. SEE CIVIL
- CONCRETE SLAB (DOLLY PAD)
- FIRE ROUTE SIGNAGE
- WATERMAIN EASEMENT, SEE CIVIL

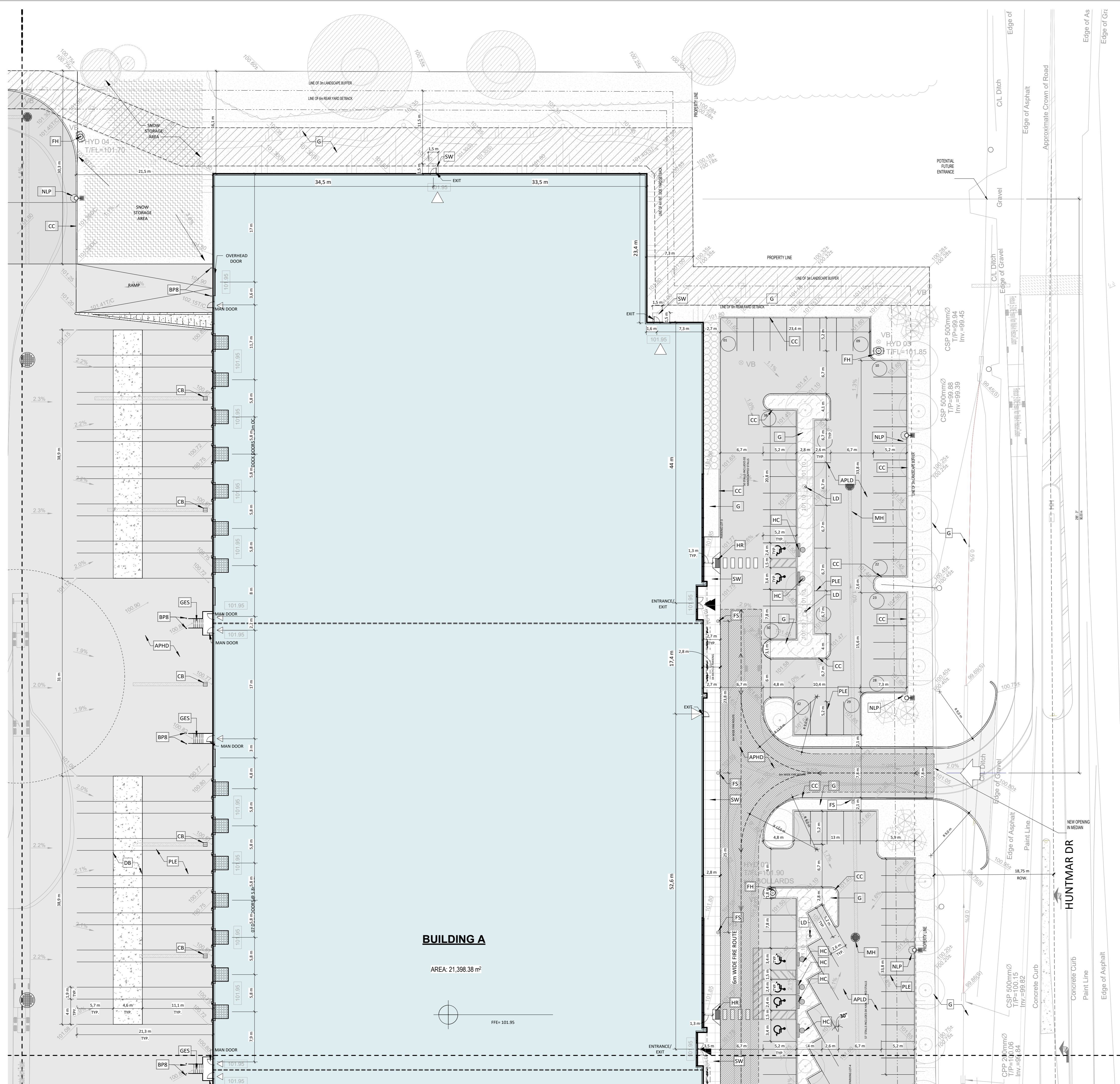

BUILDING A

AREA: 21,398.38 m²

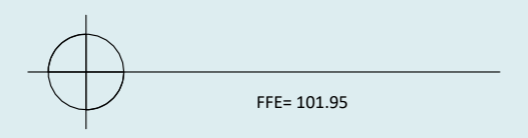

Allison Hamlin

ALLISON HAMLIN
MANAGER (A), DEVELOPMENT REVIEW WEST
PLANNING, REAL ESTATE & ECONOMIC DEVELOPMENT
DEPARTMENT, CITY OF OTTAWA

APPROVED
By Allison Hamlin at 2:57 pm, Oct 13, 2023

No.	Date	Revision	By
5	2023-09-15	ISSUED FOR SPA R4	SG
4	2023-08-04	ISSUED FOR SPA R3	SG
3	2023-05-30	ISSUED FOR SPA R2	
2	2023-03-30	ISSUED FOR SPA R1	
1	2022-12-16	ISSUED FOR SPA	

ROSEFELLOW KANATA
405 HUNTMAR DR.
CITY OF OTTAWA ONTARIO



Copyright GKC Architects. Not to be used for any other project without the architect's written consent. All dimensions and conditions must be verified on site. Do not scale drawings. Any discrepancies or omissions in the drawing shall be reported to the architect immediately in writing. All work to conform to most recent applicable norms, bylaws and codes for all given trades.

























ARCHITECTURE
ENLARGED SITE PLAN 3/4

DRAWN BY: AT CHECKED BY: AH/EB
SCALE: As indicated
FOUR: 22081

FILE NUMBER: **D07-12-22-0186**
PLAN NUMBER: **18906**
A103 R5

SYMBOLS LEGEND - SITE

DETAIL

-  NEW BUILDINGS
-  APHD ASPHALT PAVING, HEAVY DUTY, SEE CIVIL
-  APLD ASPHALT PAVING, LIGHT DUTY, SEE CIVIL
-  CC EXTERIOR CONCRETE CURB, SEE CIVIL
-  GRASS OR OTHER LANDSCAPING, SEE LANDSCAPE
-  ECB EXTERIOR CONCRETE BASE, SEE STRUCTURE FOR DETAILS
-  NEW LIGHT POLE REFER TO ELECTRICAL
-  EXSW EXISTING SIDEWALK
-  SW CONCRETE SIDEWALK, SEE CIVIL
-  HC HANDICAP PARKING SIGN
-  PLE YELLOW PAINTED LINE - EXTERIOR
-  GALVANIZED BOLLARD, 6"Ø x 5'-0" HT. OR 8"Ø x 5'-0" HT., FULL WITH CONCRETE, CLOSED END WITH GALVANIZED CAP, INSTALLED IN A CONCRETE SONOTUBE OF 20"Ø @ 5'-0" DEPTH, MIN.
-  YELLOW PAINTED BOLLARD, 6"Ø x 4'-0" HT. OR 8"Ø x 4'-0" HT., 1'-0" DEPTH, FULL WITH CONCRETE, CLOSED END WITH CAP.
-  GALVANIZED EXIT STAIR
-  HANDICAP RAMP; SEE SPECIFICATIONS / CIVIL ENGINEERING PLAN
RAMP SLOPE: 1:10-1:12
-  CHARGER FOR ELECTRIC/HYBRID VEHICLES (DOUBLE). PROVIDE 100mm HIGH CONCRETE BASE, WHEN NOT POSITIONED ON A SIDEWALK. COORDINATE THE SIZE OF THE BASE WITH CHOSEN CHARGER MODEL, SEE SPEC. AND ELECTRICAL
-  FIRE HYDRANT
-  SIAMESE FIRE DEPT. CONNECTION, SEE CIVIL AND FIRE PROTECTION
-  MANHOLE. SEE CIVIL
-  SEE CIVIL
-  CATCH BASIN. SEE CIVIL
-  CONCRETE SLAB (DOLLY PAD)
-  FIRE ROUTE SIGNAGE
-  WATERMAIN EASEMENT, SEE CIVIL

A	C
B	D

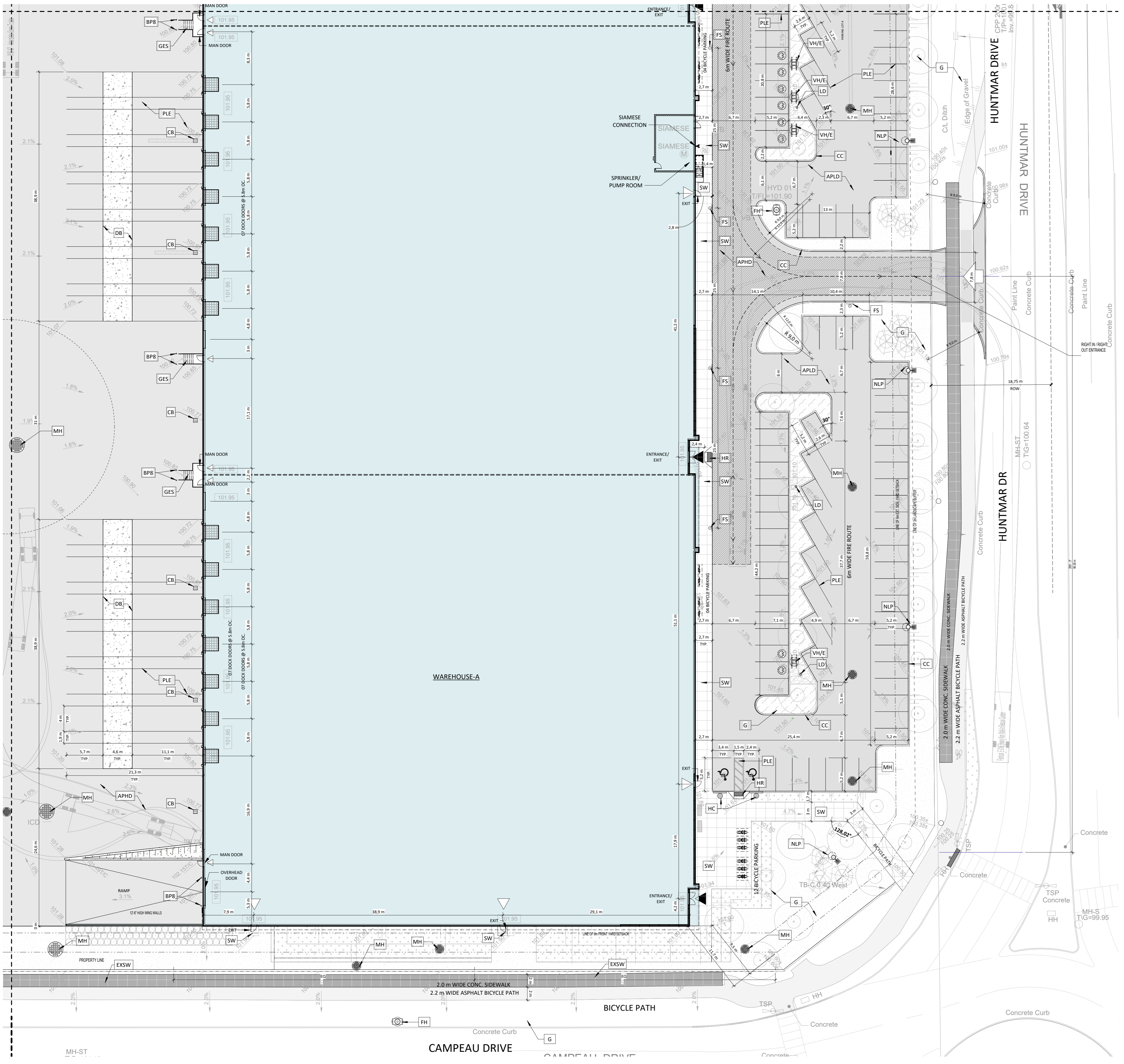
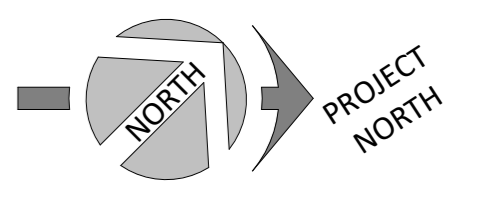

Allan Hamlin

ALLISON HAMLIN
MANAGER (A), DEVELOPMENT REVIEW WEST
PLANNING, REAL ESTATE & ECONOMIC DEVELOPMENT
DEPARTMENT, CITY OF OTTAWA

APPROVED
By Allison Hamlin at 2:57 pm, Oct 13, 2023

No.	Date	Revision	By
5	2023-09-15	ISSUED FOR SPA R4	SG
4	2023-08-04	ISSUED FOR SPA R3	SG
3	2023-05-30	ISSUED FOR SPA R2	
2	2023-03-30	ISSUED FOR SPA R1	
1	2022-12-16	ISSUED FOR SPA	

ROSEFELLOW KANATA
405 HUNTMAR DR.
CITY OF OTTAWA ONTARIO



Copyright GKC Architects. Not to be used for any other project without the architect's written consent. All dimensions and conditions must be verified on site. Do not scale drawings. Any discrepancies or omissions in the drawing shall be reported to the architect immediately in writing. All work to conform to most recent applicable norms, bylaws and codes for all given trades.

ARCHITECTURE

ENLARGED SITE PLAN 4/4

DRAWN BY: AT	CHECKED BY: AH/EB
SCALE: As indicated	FILE NUMBER: D07-12-22-0186
FOUO: 22081	TRANS NUMBER: 18906
	A104 R5

SPA ENLARGED SITE PLAN 4/4
1
1:300
A104