

SERVICING & STORMWATER MANAGEMENT REPORT WAREHOUSE DEVELOPMENT – 1881-1883 MERIVALE ROAD

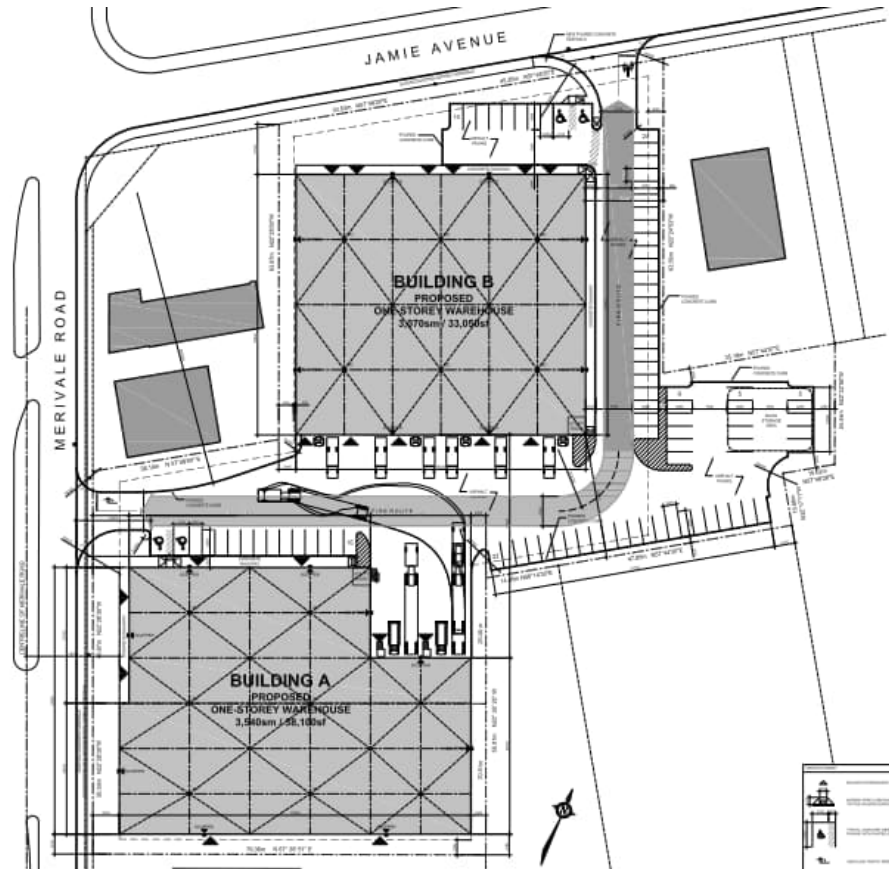

Project No.: CCO-23-1150

City File No.: D07-12-PC2022-0063

Prepared for:

Z.V. Holdings Corporation
1801 Woodward Drive
Ottawa, ON. K2C 0P9

Prepared by:

McIntosh Perry Consulting Engineers Ltd.
115 Walgreen Road
Carp, ON K0A 1L0

February 13, 2023

TABLE OF CONTENTS

1.0	PROJECT DESCRIPTION.....	1
1.1	Purpose	1
1.2	Site Description.....	1
1.3	Proposed Development and Statistics	2
1.4	Existing Conditions and Infrastructures.....	2
1.5	Approvals.....	3
2.0	BACKGROUND STUDIES.....	4
2.1	Applicable Guidelines and Standards.....	4
3.0	PRE-CONSULTATION SUMMARY.....	5
4.0	WATERMAIN.....	6
4.1	Existing Watermain	6
4.2	Proposed Watermain.....	6
5.0	SANITARY DESIGN.....	8
5.1	Existing Sanitary Sewer	8
5.2	Proposed Sanitary Sewer	8
6.0	STORM SEWER DESIGN.....	10
6.1	Existing Storm Sewers.....	10
6.2	Proposed Storm Sewers	10
7.0	PROPOSED STORMWATER MANAGEMENT.....	11
7.1	Design Criteria and Methodology.....	11
7.2	Runoff Calculations.....	11
7.3	Pre-Development Drainage.....	12
7.4	Post-Development Drainage	12
8.0	EROSION AND SEDIMENT CONTROL.....	15
8.1	Temporary Measures.....	15
8.2	Permanent Measures.....	15
9.0	SUMMARY.....	16
10.0	RECOMMENDATION	17
11.0	STATEMENT OF LIMITATIONS.....	18

LIST OF TABLES

Table 1: Water Demands.....	6
Table 2: Fire Protection Confirmation.....	7
Table 3: Sanitary Design Criteria.....	8
Table 5: Summary of Estimated Sanitary Flow	9
Table 5: Pre-Development Runoff Summary.....	12
Table 6: Post-Development Runoff Summary	12

APPENDICES

Appendix A: Site Location Plan

Appendix B: City of Ottawa Pre-Consultation Notes

Appendix C: Watermain Calculations

Appendix D: Sanitary Calculations

Appendix E: Pre-Development Drainage Plan

Appendix F: Post-Development Drainage Plan

Appendix G: Stormwater Management Calculations

Appendix H: City of Ottawa Design Checklist

1.0 PROJECT DESCRIPTION

1.1 Purpose

McIntosh Perry (MP) has been retained by Z.V. Holdings Corporation to prepare this Servicing and Stormwater Management Report in support of the Site Plan Control process for the proposed warehouse buildings, located at 1881-1883 Merivale Road within the City of Ottawa (City File No. PC2022-0063).

The main purpose of this report is to present a servicing design for the development in accordance with the recommendations and guidelines provided by the City of Ottawa (City), the Rideau Valley Conservation Authority (RVCA), and the Ministry of the Environment, Conservation and Parks (MECP). This report will address the water, sanitary and storm sewer servicing for the development, ensuring that existing and available services will adequately service the proposed development.

This report should be read in conjunction with the following drawings:

- OCO-23-1150, C101 – Site Grading, Drainage & Sediment and Erosion Control Plan, and
- OCO-23-1150, C102 – Site Servicing Plan,
- OCO-23-1150, PRE – Pre-Development Drainage Area Plan (Appendix E)
- OCO-23-1150, POST – Post-Development Drainage Area Plan (Appendix F)

1.2 Site Description



Figure 1: Site Map

The subject property, herein referred to as the site, is located at 1881 Merivale Road within the Knoxdale Merivale ward in the City of Ottawa. It is described as Lots 2 & 3, Registered Plan 564563, part of Lot 28 concession A (RF), part of Clarke Road & Pedley street, Registered Plan 382, part of Lots 76, 77, 82, 93, 94, 96 & 97 lots 78, 79, 80, & 81, Registered Plan 382, Part of Lot 2, Registered Plan 45762. The land in question covers approximately 1.40 ha and is located south of the Merivale Road and Jamie Avenue intersection. The site is zoned for general industrial use (IG). See Site Location Plan in Appendix A for more details.

1.3 Proposed Development and Statistics

The proposed development consists of two warehouse buildings. Proposed Building A and proposed Building B will be 3,540 m² and 3,070 m² in ground floor area, respectively. Parking and drive aisles will be provided throughout the site along with accesses from Merivale Road and Jamie Avenue. See Appendix B for further details.

1.4 Existing Conditions and Infrastructures

The existing site is currently developed with an existing parking lot/ storage area to the northeast of the property. There is an existing commercial building at the southwest of the property that is serviced via a well and private septic system. Storm servicing for the site is provided via municipal catch basins within Merivale Road and Jamie Avenue.

Sewer and watermain mapping collected from the City of Ottawa indicate that the following services exist across the property frontages within the adjacent municipal rights-of-way(s):

- Merivale Road
 - 406 mm diameter cast iron watermain,
 - 450 mm diameter concrete sanitary sewer tributary to the South Ottawa Collector, and a
 - 450 mm diameter concrete storm sewer tributary to the Rideau River approximately 2.8 km downstream.
- Jamie Avenue
 - 305 mm diameter ductile iron watermain,
 - 250 mm diameter PVC sanitary sewer tributary to the South Ottawa Collector, and a
 - 450-675 mm diameter concrete storm sewer tributary to the Nepean Creek and ultimately the Ottawa River.

1.5 Approvals

The proposed development is subject to the City of Ottawa site plan control approval process. Site plan control requires the City to review, provide concurrence and approve the engineering design package. Permits to construct can be requested once the City has issued a site plan agreement.

It is not anticipated that an Environmental Compliance Approval (ECA) through the Ministry of Environment, Conservation and Parks (MECP) will be required for the storm water management system because the properties are proposed to be amalgamated into a single parcel of land and are not within a combined sewer shed. ECA requirements as a result of the light industrial usage of the site are to be determined.

2.0 BACKGROUND STUDIES

As-built drawings of existing services, provided by the City of Ottawa Information centre, within the vicinity of the proposed site were reviewed in order to identify infrastructure available to service the proposed development.

A topographic survey of the site was completed by Fairhall Moffat & Woodland Ltd (Job No. AC21300) and dated October 26, 2022.

The Site Plan (SP-A01) was prepared by Microbie Architects and Interior Designers and dated January 27th, 2023 (Site Plan).

A geotechnical investigation prepared by Arcadis Canada Inc and dated January 29th, 2023.

2.1 Applicable Guidelines and Standards

City of Ottawa:

- ◆ Ottawa Sewer Design Guidelines, City of Ottawa, SDG002, October 2012. (Ottawa Sewer Guidelines)
 - Technical Bulletin ISTB-2014-01 City of Ottawa, February 2014. (ISTB-2014-01)
 - Technical Bulletin PIEDTB-2016-01 City of Ottawa, September 2016. (PIEDTB-2016-01)
 - Technical Bulletin ISTB-2018-01 City of Ottawa, January 2018. (ISTB-2018-01)
 - Technical Bulletin ISTB-2018-03 City of Ottawa, March 2018. (ISTB-2018-03)
 - Technical Bulletin ISTB-2019-01 City of Ottawa, January 2019. (ISTB-2019-01)
 - Technical Bulletin ISTB-2019-02 City of Ottawa, February 2019. (ISTB-2019-02)
- ◆ Ottawa Design Guidelines – Water Distribution City of Ottawa, July 2010. (Ottawa Water Guidelines)
 - Technical Bulletin ISD-2010-2 City of Ottawa, December 15, 2010. (ISD-2010-2)
 - Technical Bulletin ISDTB-2014-02 City of Ottawa, May 2014. (ISDTB-2014-02)
 - Technical Bulletin ISTB-2018-02 City of Ottawa, March 2018. (ISTB-2018-02)

Ministry of Environment, Conservation and Parks:

- ◆ Stormwater Planning and Design Manual, Ministry of the Environment, March 2003. (MECP Stormwater Design Manual)
- ◆ Design Guidelines for Sewage Works, Ministry of the Environment, 2008. (MECP Sewer Design Guidelines)

Other:

- ◆ Water Supply for Public Fire Protection, Fire Underwriters Survey, 2020. (FUS Guidelines)

3.0 PRE-CONSULTATION SUMMARY

A pre-consultation meeting was conducted on June 1, 2022, regarding the proposed site. Specific design parameters to be incorporated within this design include the following:

- Pre-development and post-development flows shall be calculated using a maximum time of concentration (T_c) of 10 minutes.
- Control 5 through 100-year post-development flows to the 5-year flows with a maximum combined C value of 0.50 or calculated existing value, whichever is less.
- The RVCA is to be consulted for site specific quality control measures.

The notes from the City of Ottawa can be found in Appendix B.

4.0 WATERMAIN

4.1 Existing Watermain

The site is located within the 2W2C pressure zone, as per the Water Distribution System Mapping included in Appendix C. There is an existing 406 mm diameter cast iron watermain within Merivale Road and a 305 mm diameter ductile iron watermain within Jamie Avenue. There are three public hydrants located on Merivale Road, one public hydrant located on Jamie Avenue and one public hydrant located on Bentley Avenue available to provide fire flow to the development.

4.2 Proposed Watermain

A new 150mm diameter watermain is proposed to service the site extending from the existing 300mm diameter watermain within Jamie Avenue. 150mm diameter services will extend from the proposed watermain to service Building A and Building B. Refer to drawing C102 for a detailed servicing layout.

The Fire Underwriters Survey 2020 (FUS) method was utilized to determine the required fire flow for the site. The 'C' factor (type of construction) for the FUS calculation was determined to be 1.0 (ordinary type construction). The total floor area ('A' value) for the FUS calculation was determined to be 3,540 m² and 3,070 m² for Building A and Building B, respectively. The results of the calculations yielded a required fire flow of 7,000 L/min. The detailed calculations for the FUS and can be found in Appendix C.

The water demands for the proposed building have been calculated to adhere to the Ottawa Design Guidelines – Water Distribution manual and can be found in Appendix C. The results have been summarized below. In accordance with Section 4.3.1 of the guidelines, service areas with a basic day demand greater than 50 m³/day require a dual connection to the municipal system. The basic day demand for the development is estimated to be 49.0 m³/day, therefore a dual connection is not required.

Table 1: Water Demands

Site Area	1.40 ha
Industrial - Light	35,000 L/ha/day
Average Day Demand (L/s)	0.57
Maximum Daily Demand (L/s)	0.85
Peak Hourly Demand (L/s)	1.53
FUS Fire Flow Requirement (L/s)	116.67

Boundary Conditions have been requested from the City however were not available at the time of submission. Once boundary conditions are provided by the City, the minimum and maximum water

pressures will be compared to those proposed to ensure they fall within the required range identified by in the City of Ottawa Water Supply Guidelines and to confirm the system has adequate capacity for the proposed development.

To confirm the adequacy of fire flow to protect the proposed development, public fire hydrants within 150 m of the proposed building were reviewed per City of Ottawa ISTB 2018-02 Appendix I Table 1. Based on City guidelines (ISTB-2018-02), the existing hydrants can provide adequate fire coverage to the proposed development. The results are summarized below.

Table 2: Fire Protection Confirmation

Building	Fire Flow Demand (L/min.)	Fire Hydrant(s) within 75m*	Fire Hydrant(s) within 150m*	Combined Fire Flow (L/min.)
Building A	7,000 (FUS)	2	3	22,800
Building B	7,000 (FUS)	2	2	19,000

* Fire hydrants within 75 metres contribute 5,700 L/min to fire flow and fire hydrants within 150 meters contribute 3,800 L/min to fire flow, respectively, per ISTB-2018-02.

5.0 SANITARY DESIGN

5.1 Existing Sanitary Sewer

There is a 450 mm diameter concrete sanitary sewer within Merivale Road. There is an existing 250 mm diameter PVC sanitary sewer within Jamie Avenue. Sanitary flow from the sewers is tributary to the South Ottawa Collector Sewer per the City of Ottawa Trunk Sewer Map figure available in Appendix 'D'.

5.2 Proposed Sanitary Sewer

A new 150 mm diameter service is proposed to be connected to the existing 250 mm diameter sanitary sewer within Jamie Avenue at the existing sanitary manhole (MHSA18556). 135 mm diameter service laterals are proposed to service Building A and Building B, extending from the proposed 150 mm diameter sewer. It is anticipated that monitoring would occur at MHSA18556. Refer to drawing C102 for a detailed servicing layout.

The proposed development consists of two warehouse buildings. The peak design flows for the proposed buildings were calculated using criteria from the Ottawa Sewer Guidelines and are summarized in Table 3, below. Based on the unit occupancy statistics provided by the architect, the proposed site development will generate a flow of 4.30 L/s. See Appendix 'D' of this report for more details.

Table 3: Sanitary Design Criteria

Design Parameter	Value
Ste Area	1.40 ha
Industrial Demand (Light)	35,000 L/gross ha/d
Industrial Peaking Factor	6.30
Extraneous Flow Allowance	0.33 L/s/ha

Table 4 below, summarizes the estimated wastewater flow from the proposed development. Refer to Appendix 'D' for detailed calculations.

Table 4: Summary of Estimated Sanitary Flow

Design Parameter	Total Flow (L/s)
Total Estimated Average Dry Weather Flow	0.07
Total Estimated Peak Dry Weather Flow	3.64
Total Estimated Peak Wet Weather Flow	4.03

The proposed sanitary network has been design to attain a minimum full flow target velocity (cleansing velocity) of 0.6 m/s and a full flow velocity of not more than 3.0 m/s. The capacity of the proposed sanitary sewer with a slope of 0.32% is 8.99 L/s based on sanitary sewer design calculations available in Appendix 'D'.

Due to the complexity of the downstream network, the City will need to advise of any downstream constraints.

6.0 STORM SEWER DESIGN

6.1 Existing Storm Sewers

The site is located within the Lower Rideau Sub Watershed. There is an existing 450mm diameter concrete storm sewer within Merivale Road and a 450-675mm diameter concrete storm sewer within Jamie Avenue. Both storm sewers are ultimately tributary to the Rideau River.

6.2 Proposed Storm Sewers

A new 525mm diameter storm sewer is proposed to be extended from the existing 675 mm diameter storm sewer within Jamie Avenue (at storm maintenance structure MHST18383). The 525 mm diameter storm sewer is proposed to be a dry pipe to allow for foundation drainage to be conveyed to the existing 675 mm diameter sewer without attenuation.

Runoff from the parking lot areas and drive aisles will be collected by existing and proposed catch basins. Surface runoff will be attenuated by ICDs on the outlets of CB1-CB4 before discharging to the proposed 525 mm diameter storm sewer.

Runoff from the loading area fronting Building A will be collected by a trench drain and conveyed without attenuation via the internal mechanical system towards the 525 mm diameter storm sewer.

Runoff collected from the roofs of Building A and Building B will be collected and attenuated by eight and six roof drains, respectively. Roof drainage will then discharge to the proposed 525mm storm sewer.

See drawing C102 for a detailed servicing layout and OOO-23-1150 - POST included in Appendix 'F' of this report for more details. The Stormwater Management design for the subject property will be outlined in Section 7.0 of this report.

7.0 PROPOSED STORMWATER MANAGEMENT

7.1 Design Criteria and Methodology

Stormwater management for the proposed site will be maintained through two methods. The first will store and control runoff collected on the roof of the proposed buildings. Building A and Building B will use eight- and six-Watts Accutrol Weirs (fully closed), respectively, to control the release rate of the roof drainage. The second will control stormwater via an underground sewer system(s) and will collect runoff from the at-grade areas within the site. The flow will be directed to the proposed 525 mm diameter sewer where it will ultimately discharge to the existing 675 mm diameter sewer within Jamie Avenue.

The following design criteria has been employed in developing the stormwater management design for the site as directed by the RVCA and City:

Quality Control

- Quality controls are not required for the development due to the distance to the outlet.

Quantity Control

- Post-development flow 5/100-year is be restricted to match the 5-year pre-development flow with a maximum C value of 0.50.

7.2 Runoff Calculations

Runoff calculations presented in this report are derived using the Rational Method, given as:

$$Q = 2.78CIA \text{ (L/s)}$$

Where:

C	=	Runoff coefficient
I	=	Rainfall intensity in mm/hr (City of Ottawa IDF curves)
A	=	Drainage area in hectares

It is recognized that the Rational Method tends to overestimate runoff rates. As a result, the conservative calculation of runoff ensures that any SWM facility sized using this method is expected to function as intended.

The following coefficients were used to develop an average C for each area:

Roofs/ Concrete/ Asphalt	0.90
Gravel	0.70
Undeveloped and Grass	0.20

As per the City of Ottawa - Sewer Design Guidelines, the 5-year balanced 'C' value must be increased by 25% for a 100-year storm event to a maximum of 1.0.

As per the pre-consultation meeting with the City of Ottawa the time of concentration (Tc) used for pre-development shall be determined using a calculated Tc of no less than 10 minutes and post-development flows shall be calculated using a Tc of 10 minutes.

7.3 Pre-Development Drainage

It has been assumed that the site contains no stormwater management controls for flow attenuation. The estimated pre-development peak flows for the 5, and 100-year events are summarized below in Table 5. See COO-23-1150 - PRE in Appendix E and Appendix G for calculations.

Table 5: Pre-Development Runoff Summary

Drainage Area	C 5-Year	C 100-Year	Area (ha)	Q (L/s)	
				5-Year	100-Year
A1	0.32	0.40	1.40	96.48	205.08
Total			1.40	96.48	205.08

7.4 Post-Development Drainage

The proposed site drainage limits are demonstrated on the Post-Development Drainage Area Plan. See COO-23-1150 - POST in Appendix 'F' of this report for more details. A summary of the Post-Development Runoff Calculations can be found below.

Table 6: Post-Development Runoff Summary

Drainage Area	Area (ha)	5-Year Peak Flow (L/s)	100-Year Peak Flow (L/s)	100-Year Storage Requirement (m ³)	100-Year Storage Available (m ³)
B1	0.35	2.52	2.52	237.61	238.95
B2	0.31	1.89	1.89	213.93	218.74
B3	0.19	27.10	28.48	40.10	40.14
B4	0.20	9.50	10.00	63.63	66.23
B5	0.06	1.94	1.98	25.10	26.61
B6	0.12	2.00	2.10	29.09	31.90
B7	0.03	5.49	10.63	-	-
B8	0.11	11.92	23.85	-	-
B9	0.02	5.22	9.94	-	-
Total	1.40	67.58	91.40	609.46	622.57

Post development drainage will be restricted to a maximum release rate of 91.40 L/s based on a maximum release rate requirement of 96.48 L/s.

To meet the stormwater objectives the development will contain a combination of flow attenuation with rooftop controls, surface and subsurface storage.

Runoff for area B1 will be stored on the roof of the proposed Building A and restricted using eight (8) fully closed Watts Accutrol roof drains (or approved equivalent) to a maximum release rate of 2.52 L/s and will provide up to 238.95 m³ of surface storage.

Runoff for area B2 will be stored on the roof of the proposed Building B and restricted using six (6) fully closed Watts Accutrol roof drains (or approved equivalent) to a maximum release rate of 1.89 L/s and will provide up to 218.74 m³ of surface storage.

Runoff for area B3 will be restricted before discharging to the proposed 525 mm diameter storm sewer. The flow will be controlled within a catch basin structure (CB1) installed with a 101 mm plug style ICD. Drainage will be restricted to a maximum release rate of 28.48 L/s and will provide up to 40.14 m³ of storage via surface storage and a Triton storage tank (or approved equivalent) stormwater chamber system. Detailed tank drawings are available in Appendix G.

Runoff for area B4 will be restricted before discharging to the proposed 525 mm diameter storm sewer. The flow will be controlled within a catch basin structure (CB2) installed with a Tempest LMF90 ICD (or approved equivalent). Drainage will be restricted to a maximum release rate of 10.00 L/s and will provide up to 66.23m³ of storage via surface storage. Refer to Iplex Tempest ICD sizing charts and detailed calculations located in Appendix G.

Runoff for area B5 will be restricted before discharging to the proposed 525 mm diameter storm sewer. The flow will be controlled within a catch basin structure (CB3) installed with a Tempest LMF40 ICD (or approved equivalent). Drainage will be restricted to a maximum release rate of 1.98 L/s and will provide up to 26.61 m³ of storage via surface storage. Refer to Iplex Tempest ICD sizing charts and detailed calculations located in Appendix G.

Runoff for area B6 will be restricted before discharging to the proposed 525 mm diameter storm sewer. The flow will be controlled within a catch basin structure (CB4) installed with a Tempest LMF45 ICD (or approved equivalent). Drainage will be restricted to a maximum release rate of 2.10 L/s and will provide up to 31.90 m³ of storage via surface storage. Refer to Iplex Tempest ICD sizing charts and detailed calculations located in Appendix G.

Runoff for area B7 will be directed the Jamie Avenue right of way without attenuation and will be compensated for in areas with attenuation.

Runoff for area B8 will be directed the Merivale Road right of way without attenuation and will be compensated for in areas with attenuation.

Runoff for area B9 will be collected by a trench drain structure (TD1) and conveyed to the proposed 525 mm diameter storm sewer without attenuation.

8.0 EROSION AND SEDIMENT CONTROL

8.1 Temporary Measures

Before construction begins, temporary silt fence, straw bale or rock flow check dams will be installed at all natural runoff outlets from the property. It is crucial that these controls be maintained throughout construction and inspection of sediment and erosion control will be facilitated by the Contractor or Contract Administration staff throughout the construction period.

Silt fences will be installed where shown on the final engineering plans, specifically along the downstream property limits. The Contractor, at their discretion or at the instruction of the City, Conservation Authority or the Contract Administrator shall increase the quantity of sediment and erosion controls on-site to ensure that the site is operating as intended and no additional sediment finds its way off site. The rock flow, straw bale & silt fence check dams and barriers shall be inspected weekly and after rainfall events. Care shall be taken to properly remove sediment from the fences and check dams as required. Fibre roll barriers are to be installed at all existing curb inlet catchbasins and filter fabric is to be placed under the grates of all existing catchbasins and manholes along the frontage of the site and any new structures immediately upon installation. The measures for the existing/proposed structures is to be removed only after all areas have been paved. Care shall be taken at the removal stage to ensure that any silt that has accumulated is properly handled and disposed of. Removal of silt fences without prior removal of the sediments shall not be permitted.

Although not anticipated, work through winter months shall be closely monitored for erosion along sloped areas. Should erosion be noted, the Contractor shall be alerted and shall take all necessary steps to rectify the situation. Should the Contractor's efforts fail at remediating the eroded areas, the Contractor shall contact the City and/or Conservation Authority to review the site conditions and determine the appropriate course of action. As the ground begins to thaw, the Contractor shall place silt fencing at all required locations as soon as ground conditions warrant. Please see the Site Grading, Drainage and Sediment & Erosion Control Plan for additional details regarding the temporary measures to be installed and their appropriate OPSD references.

8.2 Permanent Measures

It is expected that the Contractor will promptly ensure that all disturbed areas receive topsoil and seed/ sod and that grass be established as soon as possible. Any areas of excess fill shall be removed or levelled as soon as possible and must be located a sufficient distance from any watercourse to ensure that no sediment is washed out into the watercourse. As the vegetation growth within the site provides a key component to the control of sediment for the site, it must be properly maintained once established. Once the construction is complete, it will be up to the landowner to maintain the vegetation and ensure that the vegetation is not overgrown or impeded by foreign objects.

9.0 SUMMARY

- Two new warehouse buildings are proposed at 1881-1883 Merivale Road.
- A new 150 mm diameter watermain is proposed to service the site with a connection to the 305 mm diameter watermain within Jamie Avenue.
- A new 150 mm diameter sanitary sewer is proposed to service the site with a connection to the 250 mm diameter sanitary sewer within Jamie Avenue.
- The proposed storm sewer system, ranging in diameter from 250 mm to 525mm, will service the site. The storm service will discharge stormwater into the 675 mm sewer within Jamie Avenue via a proposed 525 mm diameter storm sewer.
- Storage for the 5- through 100-year storm events will be provided via rooftop storage, the parking lot areas above the proposed storm structures and via surface storage.

10.0 RECOMMENDATION

Based on the information presented in this report, we recommend that City of Ottawa approve this Servicing and Stormwater Management Report in support of the proposed warehouse buildings at 1881-1883 Merivale Road.

This report is respectfully being submitted for approval.

Regards,

McIntosh Perry Consulting Engineers Ltd.



Robert D. Freel, P.Eng.
Senior Project Manger, Land Development
T: 613.714.6174
E: r.freel@mcintoshperry.com

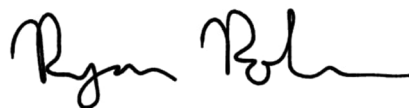

Ryan R. Robineau, E.I.T.
Civil Engineering Technologist, Land Development
T: 613.714.6611
E: r.robineau@mcintoshperry.com

11.0 STATEMENT OF LIMITATIONS

This report was produced for the exclusive use of Z.V. Holdings Corporation. The purpose of the report is to assess the existing stormwater management system and provide recommendations and designs for the post-construction scenario that are in compliance with the guidelines and standards from the Ministry of the Environment, Conservation and Parks, City of Ottawa and local approval agencies. McIntosh Perry reviewed the site information and background documents listed in Section 2.0 of this report. While the previous data was reviewed by McIntosh Perry and site visits were performed, no field verification/measures of any information were conducted.





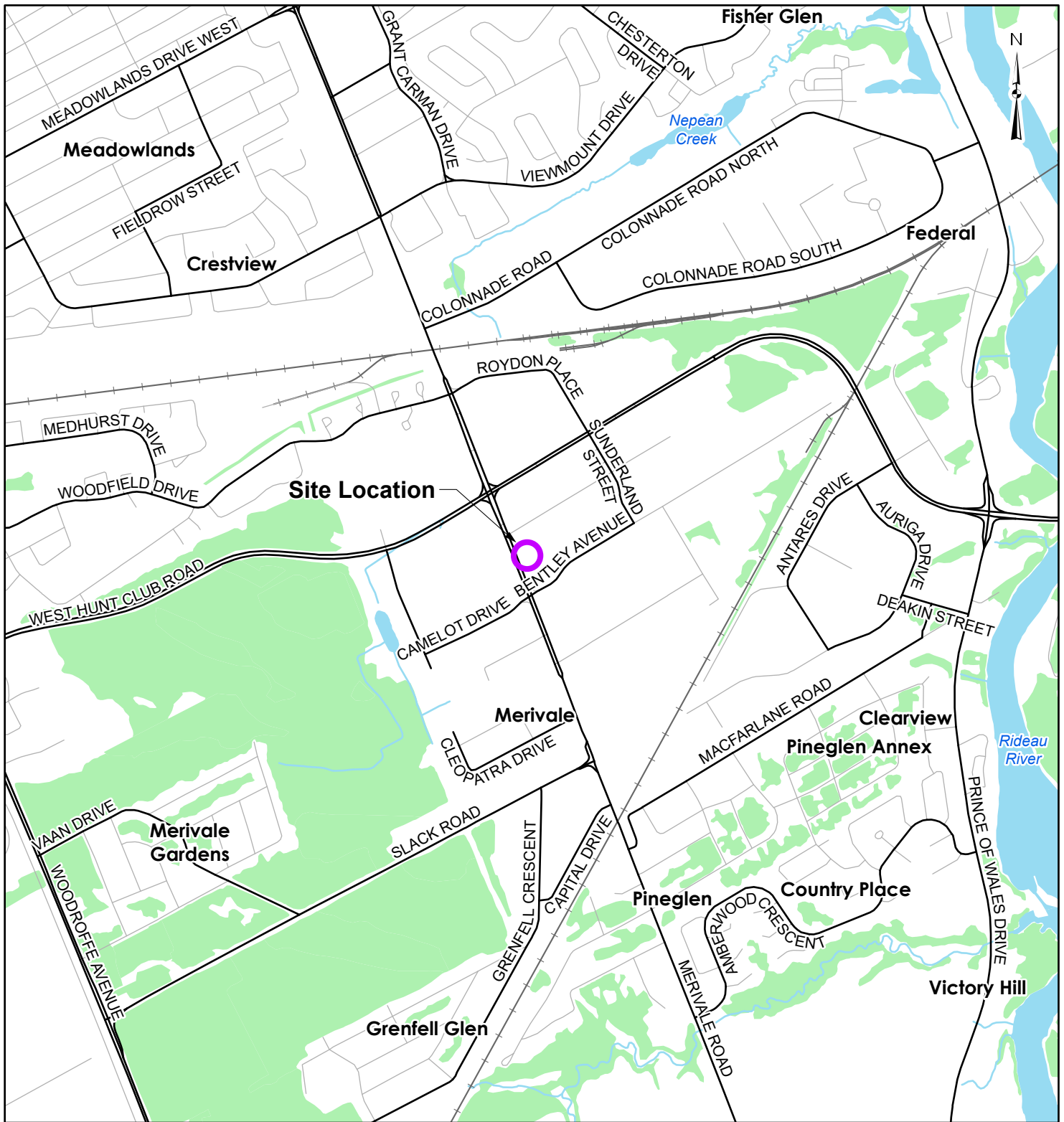

Any use of this review by a third party, or any reliance on decisions made based on it, without a reliance report is the responsibility of such third parties. McIntosh Perry accepts no responsibility for damages, if any, suffered by any third party as a result of decisions or actions made based on this review.

The findings, conclusions and/or recommendations of this report are only valid as of the date of this report. No assurance is made regarding any changes in conditions subsequent to this date. If additional information is discovered or becomes available at a future date, McIntosh Perry should be requested to re-evaluate the conclusions presented in this report, and provide amendments, if required.

APPENDIX A
KEY PLAN



LEGEND

-  Site Location
-  Local Road
-  Major Road
-  Railroad
-  Watercourse
-  Waterbody
-  Wooded Area



REFERENCE

GIS data provided by the Ontario Ministry of Northern Development, Mines, Natural Resources and Forestry, 2022.

CLIENT:	ARNON DEVELOPMENT CORPORATION LIMITED		
PROJECT:	LIGHT INDUSTRIAL WAREHOUSE DEVELOPMENT		
TITLE:	SITE LOCATION		
	PROJECT NO: CCO-23-1150	FIGURE:	1
Date	Jul., 29, 2022		
GIS	AH		
Checked By	RR		

McINTOSH PERRY
 115 Walgreen Road, RR3, Carp, ON K0A1L0
 Tel: 613-836-2184 Fax: 613-836-3742
 www.mcintoshperry.com

APPENDIX B
BACKGROUND DOCUMENTS

Pre-Application Consultation Meeting Minutes

Property Address: 1881-1883 Merivale Road

Location: Virtual – Microsoft Teams

Meeting Date: June 1, 2022

Attendees: Colette Gorni – Planner (File Lead), City of Ottawa
Jessica Valic – Project Manager (Infrastructure), City of Ottawa
Mark Richardson, Planner (Forester), City of Ottawa
Patrick McMahon – Project Manager (Transportation), City of Ottawa
Matthew Ippersiel – Planner (Urban Design), City of Ottawa
Louise Cerveny – Planner (Parks), City of Ottawa
Steven Payne – Co-op Student, City of Ottawa
Peter Hume – Applicant
David Young – Owner, Arnon Development Corporation Ltd.

Regrets: Sami Rehman – Planner (Environment), City of Ottawa
Eric Lalonde – Planner, RVCA

Applicant Comments

1. The subject site includes the following properties: 1881 and 1883 Merivale Road, and 6 and 12 Jamie Avenue.
2. The proposal consists of two, one-storey warehouse buildings with a total combined GFA of 6,610m². Building A has a GFA of 3,540m², is located on the southern portion of the site, and has frontage along Merivale Road. Building B has a GFA of 3,070m², is located on the northern portion of the site, and has frontage on Jamie Avenue.
3. A total of 90 vehicle parking spaces are proposed on site and are located throughout the site. Parking is to be shared by the two buildings.
4. Loading spaces have been strategically located so that they are not visible from Merivale Road.
5. The site will be accessed from two accesses, located on Merivale Road and Jamie Avenue, respectively.

Planning

1. Ensure that all measurements required to confirm zoning conformance are included on the plans.
2. Provide more information on how waste management is being handled on site. If being stored outside, please refer to Section 110(3) of the Zoning By-law.

3. Provide more information on how snow storage will be handled on site. If being stored on site, please ensure that snow storage areas are shown on the site plan.
4. Ensure that all addresses forming the subject site are identified on the application form, plans, reports, etc. in the formal submission.
5. A Site Plan Control – Complex application is required to permit the proposed development. More information on the process, timelines, fees, forms, etc. can be found [here](#).

Feel free to contact Colette Gorni, Planner (File Lead), at Colette.Gorni@ottawa.ca for follow-up questions.

Transportation

1. Follow Traffic Impact Assessment Guidelines
 - a. Start this process as soon as possible.
 - b. The application will not be deemed complete until the submission of the draft step 1-4. Collaboration and communication between development proponents and City staff are required at the end of every step of the TIA process.
 - c. No Noise Impact Study is required with a warehouse land use. However, this development is within the 25 NEF/NEP line for aircraft noise making this a good candidate for air conditioning should an office use be pursued.
2. Clear throat requirement as per TAC appear to be 15m on Merivale Road for Light Industrial developments of less than 10,000m².
3. On site plan:
 - a. Show all details of the roads abutting the site up to and including the opposite curb; include such items as pavement markings, accesses and/or sidewalks.
 - b. Turning templates will be required for all accesses showing the largest vehicle to access the site; required for internal movements and at all access (entering and exiting and going in both directions).
 - c. Show all curb radii measurements; ensure that curb radii for any non-truck access are reduced as much as possible.
 - d. Show lane/aisle widths.
 - e. Sidewalk is (not) to be continuous across access as per City Specification 7.1.

4. Merivale Road has a protected right-of-way of 37.5m. Ensure that this is shown on the plan.
5. Upgrade the sidewalk to concrete along Merivale frontage and extend along Jamie frontage.
6. 1 bicycle parking space per 2,000 m² is required for warehouse uses.
7. Ensure that previous accesses no longer in use are removed and sidewalks reinstated.
8. A bus stop exists on Merivale near an existing access, relocation may be required.

Feel free to reach out to Patrick McMahon, Transportation Project Manager, at Patrick.McMahon@ottawa.ca.

Urban Design

1. Efforts to locate the loading bays and the majority of parking away from the public realm are appreciated.
2. Articulate the facades facing the public realm as much as possible to provide visual interest. Blank walls should be avoided, particularly facing Merivale and glazing is required.
3. As tenants are secured and the floorplans of the buildings are refined, please aim to locate retail, offices, break rooms or other active uses at the front of the buildings and have them coupled with glazing to help animate the facade.
4. Main entrances should be prominently expressed and visible from the streets. Consider accentuating the north-west corner of Building A with additional glazing and/or architectural expression to highlight the entrances in this location make them more legible and welcoming.
5. Consider opportunities for outdoor seating areas (such as picnic tables) for employee use on the property. Accompany these areas with trees for shade where possible.
6. A generous landscaping treatment including a row of trees is strongly encouraged along the Merivale frontage.
7. An Urban Design Brief is required as a part of your submission. This may be combined with your Planning Rationale report (if required). Please refer to the attached Urban Design Brief Terms of Reference to inform the content of the brief.
8. This application is not subject to review by the Urban Design Review Panel.

Feel free to contact Matthew Ippersiel, Urban Design Planner, at Matthew.Ippersiel@ottawa.ca for follow-up questions.

Engineering

Infrastructure – Water

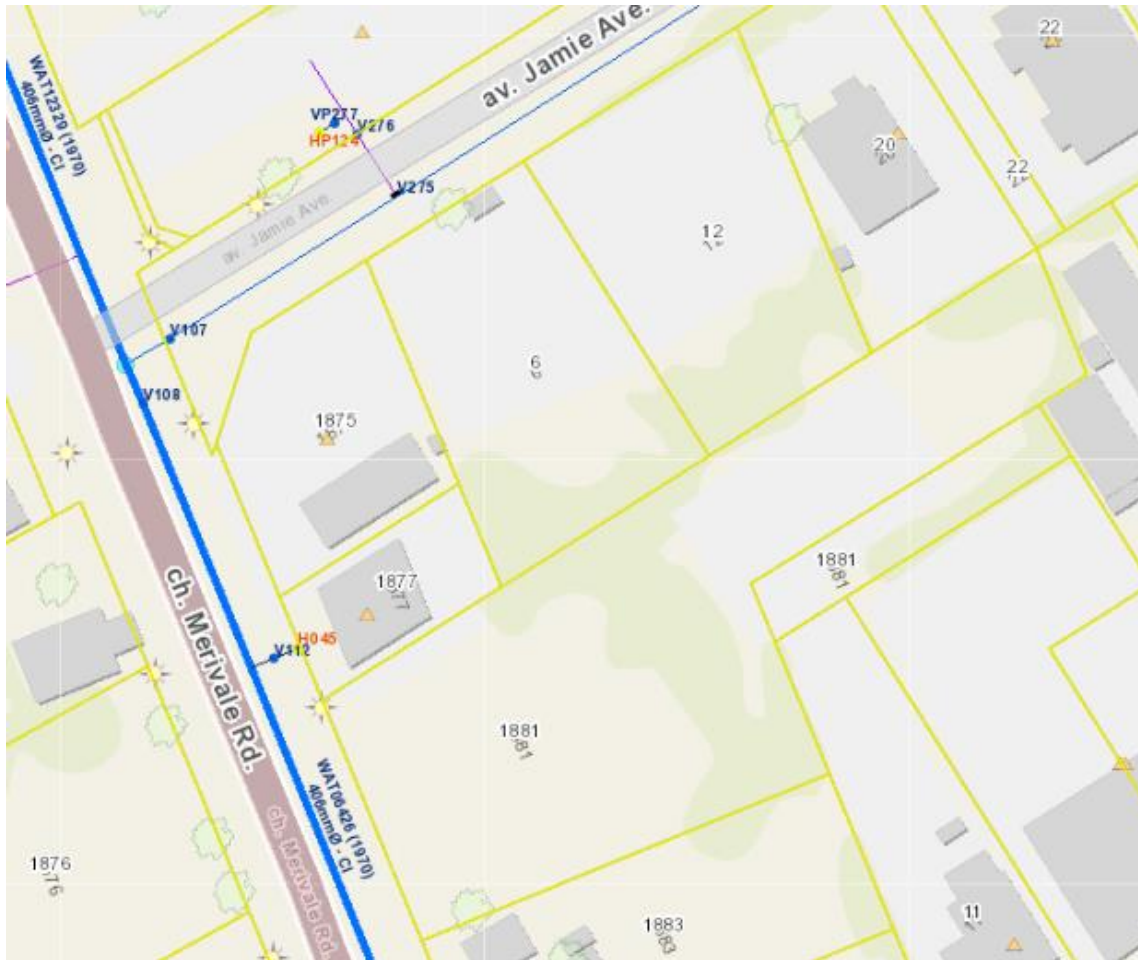

1. Available Watermains – Jamie Ave: 305mm DI (1976); Merivale Rd: 406mm CI (1970)
 - a. Backbone watermain on Merivale Rd fronts property. Connection to this main is not permitted as there is a local main available on Jamie Ave
 - b. Per WDG 4.3.1, where basic demand is greater than 50 m³/day, there shall be a minimum of two water services, separated by an isolation valve, to avoid creation of vulnerable service area
 - c. Per WDG 4.4.7.2, District Meter Area (DMA) Chamber is required for services greater than 150mm in diameter
 - d. Assess hydrant capacity to ensure Required Fire Flow can be achieved and include hydrant coverage map/analysis in servicing report
 - e. Demonstrate that adequate pressure is available throughout the distribution network on site through hydraulic watermain analysis

residential and multi-residential building connections from a private sewer to a public sewer. See Sewer Use By-Law 2003-514(14).

- b. Connection to the local main on Jamie Ave is preferred to limit road cuts on arterial roads (Merivale)
- c. For rigid mains, where service lateral connection is greater than 50% of the diameter of the main sewer, a maintenance hole will be required at the connection

Infrastructure – Storm

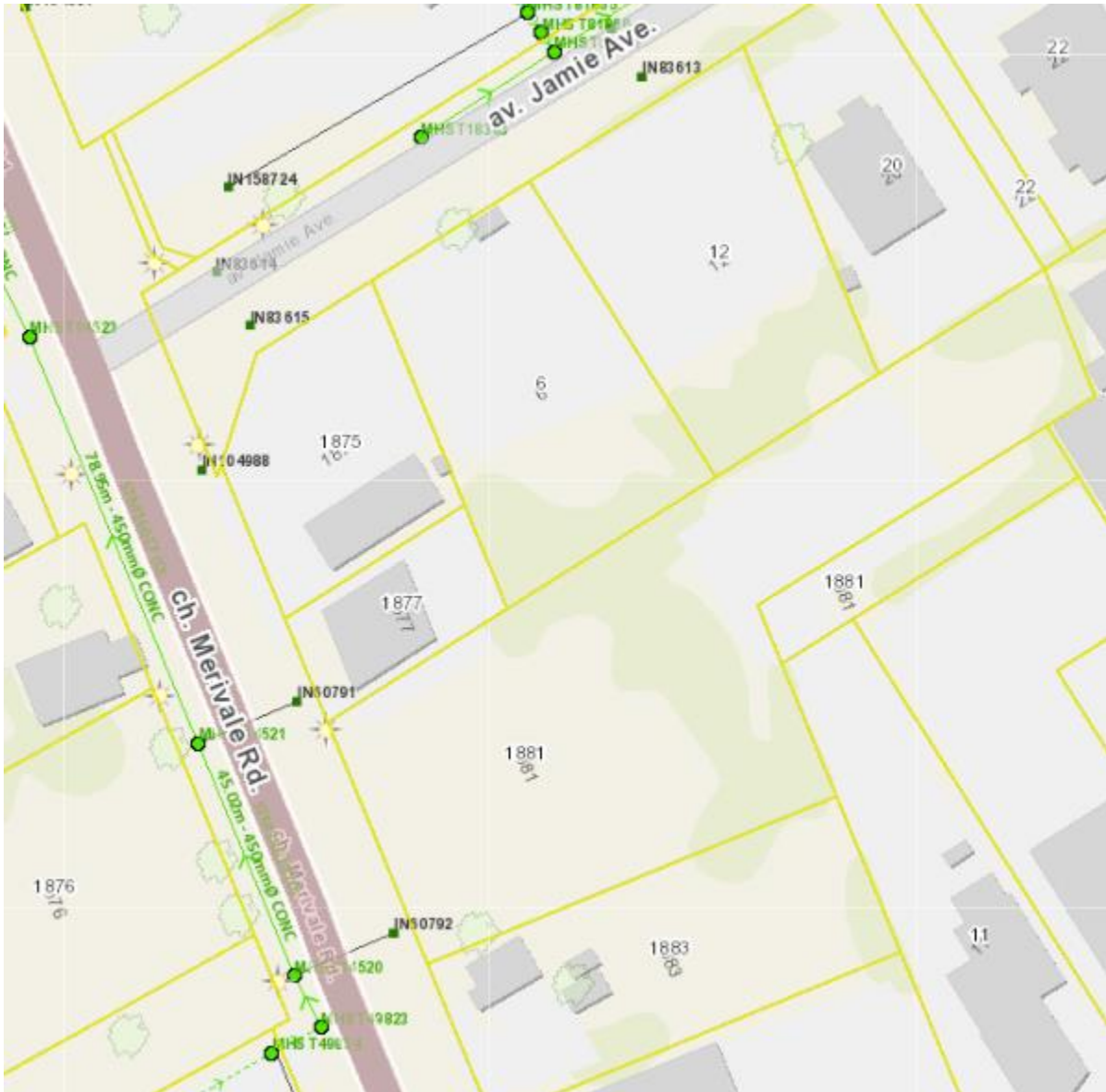

4. Available Storm: Jamie Ave: 450mm CONC (1981); Merivale Rd: 450mm CONC

- a. Connection to the local main on Jamie Ave is preferred to limit road cuts on arterial roads (Merivale)

- b. As per the Ottawa Sewer Design Guidelines, a monitoring maintenance hole is required just inside the property line for all non-residential and multi-residential building connections from a private sewer to a public sewer.

Stormwater Management

5. Quantity Control:

- a. Control the 100-yr event to the 5-year event
- b. Runoff coefficient (c)=0.5 or C=pre-development, whichever is less
- c. Time of concentration (Tc): Calculated or minimum of Tc=10min
- d. As per Technical Bulletin ISTB-2016-01, there shall be no surface ponding on private parking areas during the 2-year storm rainfall event. Depending on the SWM strategy proposed, underground storage may be required
- e. If underground/inline stormwater storage is proposed, an average release rate equal to 50% of the determined peak allowable rate must be used. Otherwise, disregard the underground/inline storage as available storage or provide modeling to support the proposed design. The reasoning for this restriction is that the discharge rate at full storage is not representative of the discharge rate for more frequent storm events. Halving the discharge rate compensates for the inaccuracies of the modified rational method when underground storage is used.
- f. MECP ECA may be required for this development (Industrial Zoning). ECA will either be via Transfer of Review or Direct Submission. This can be determined at the time of Site Plan Application.
- g. MECP ECA may be required for drainage crossing property lines if these parcels will not be merged on title. This can be determined at the time of Site Plan Application.
- h. Comment on the need for MECP ECA approval within the Servicing/Stormwater Management Report.
- i. Provide both pre and post development stormwater management plans, showing individual drainage areas and their respective coefficients.
- j. Show overland flow route and limits of any proposed ponding on grading and SWM Plans.
- k. If roof storage is proposed, please provide a roof drainage plan showing the 5 and 100-year storm ponding levels. Include the roof drain type, opening settings, ponding depth, and flow rate.
- l. Roof drains to be connected downstream of any incorporated ICD within the SWM system.

- m. Where service lateral connection is greater than 50% of the diameter of the main sewer, a maintenance hole will be required at the connection.
6. Quality Control
- a. Please consult with the Rideau Valley Conservation Authority (RVCA) regarding water quality control restrictions for the subject site. Include correspondence in report.

Phase I and II ESA

- 7. Phase I ESA is a requirement; Phase II ESA requirement will be dependent on the result of the Phase I ESA.
- 8. Phase I ESA must include Ecolog ERIS Report.
- 9. Phase I ESAs and Phase II ESAs must conform to clause 4.8.4 of the Official Plan that requires that development applications conform to Ontario Regulation 153/04.
- 10. Phase I/II ESA to comment on the need for a Record of Site Condition for property development.

Geotechnical Investigation

- 11. Required for entire development area
- 12. Retaining walls greater than 1.0m must be designed by a Professional Engineer. Submit Engineered drawings for any retaining walls greater than 1.0 meters with application.

Exterior Lighting

- 13. If exterior light fixtures are proposed, provide a plan showing the location of all exterior fixtures and include a table providing fixture details (make, model, mounting heights). All external light fixtures must meet the criteria for full cut-off classification as recognized by the Illuminating Engineering Society of North America (IESNA or IES), resulting in minimal light spillage onto adjacent properties (as a guideline, 0.5 fc is normally the maximum allowable spillage). Provide certification from a relevant Professional Engineer.

Other

- 14. Connect to mains on Jamie Ave. Group services in common trench to minimize number of roadcuts.
- 15. The Servicing Study Guidelines for Development Applications are available at the following address: <https://ottawa.ca/en/city-hall/planning-and-development/information-developers/development-application-review-process/development-application-submission/guide-preparing-studies-and-plans#servicing-study-guidelines-development-applications>
- 16. Servicing and site works shall be in accordance with the following documents:

- a. Ottawa Sewer Design Guidelines (October 2012) (including subsequent Technical Bulletins)
 - b. Ottawa Design Guidelines – Water Distribution (2010) (including subsequent Technical Bulletins)
 - c. Geotechnical Investigation and Reporting Guidelines for Development Applications in the City of Ottawa (2007)
 - d. Ottawa Standard Tender Documents (latest version)
17. Record drawings and utility plans are also available for purchase from the City (Contact the City's Information Centre by email at InformationCentre@ottawa.ca or by phone at (613) 580-2424 x.44455).
18. Any proposed work in utility easements requires written consent of easement owner.
19. All submitted report and plan pdf documents to be flattened and unsecured to allow for editing.
20. All documents prepared by Engineers shall be signed and dated on the seal.

Should you have any questions or require additional information, please contact me directly at Jessica.Valic@ottawa.ca.

Parks

1. Pursuant to Section 3 and Section 10 Parkland Dedication By-law 2009-05, as amended, cash-in-lieu (CIL) of parkland shall be paid at the time of Site Plan Control approval. Parks will collect cash-in-lieu of parkland at a rate of 2% of the value of area of the site to be developed.
2. The land valuation shall be determined as of the day before Site Plan Control approval and shall be at the cost of the Owner.
3. Parks and Facilities Planning is currently undertaking a legislated review for the replacement of the Parkland Dedication By-law, with the new by-law to be considered by City Council in early July 2022. To ensure you are aware of parkland dedication requirements for your proposed development, we encourage you to familiarize yourself with the [existing Parkland Dedication By-law](#) and to sign up for project notifications on the [Engage Ottawa project page](#) or by emailing the project lead at Kersten.Nitsche@ottawa.ca

Feel free to contact Louise Cerveny, Parks Planner, at Louise.Cerveny@ottawa.ca for follow-up questions.

Forestry

TCR requirements:

1. A Tree Conservation Report (TCR) must be supplied for review along with the suite of other plans/reports required by the City.
 - a. an approved TCR is a requirement of Site Plan approval.
 - b. The TCR may be combined with the LP provided all information is supplied.
2. Any removal of privately-owned trees 10cm or larger in diameter, or city-owned trees of any diameter requires a tree permit issued under the Tree Protection Bylaw (Bylaw 2020 – 340); the permit will be based on an approved TCR and made available at or near plan approval.
3. The Planning Forester from Planning and Growth Management as well as foresters from Forestry Services will review the submitted TCR.
 - a. If tree removal is required, both municipal and privately-owned trees will be addressed in a single permit issued through the Planning Forester.
 - b. Compensation may be required for city owned trees – if so, it will need to be paid prior to the release of the tree permit.
4. The TCR must list all trees on site, as well as off-site trees if the CRZ extends into the developed area, by species, diameter and health condition.
5. Please identify trees by ownership – private onsite, private on adjoining site, city owned, co-owned (trees on a property line).
6. If trees are to be removed, the TCR must clearly show where they are, and document the reason they cannot be retained.
7. All retained trees must be shown, and all retained trees within the area impacted by the development process must be protected as per City guidelines available at [Tree Protection Specification](#) or by searching Ottawa.ca.
 - a. The location of tree protection fencing must be shown on the plan.
 - b. Show the critical root zone of the retained trees.
 - c. If excavation will occur within the critical root zone, please show the limits of excavation.
8. The City encourages the retention of healthy trees; if possible, please seek opportunities for retention of trees that will contribute to the design/function of the site.

For more information on the process or help with tree retention options, contact Mark Richardson mark.richardson@ottawa.ca or on [City of Ottawa](https://www.cityofottawa.ca)

Landscape Plan Tree Planting Requirements:

9. Minimum Setbacks

- a. Maintain 1.5m from sidewalk or MUP/cycle track or water service laterals.
- b. Maintain 2.5m from curb
- c. Coniferous species require a minimum 4.5m setback from curb, sidewalk or MUP/cycle track/pathway.
- d. Maintain 7.5m between large growing trees, and 4m between small growing trees. Park or open space planting should consider 10m spacing, except where otherwise approved in naturalization / afforestation areas. Adhere to Ottawa Hydro's planting guidelines (species and setbacks) when planting around overhead primary conductors.

10. Tree specifications

- a. Minimum stock size: 50mm tree caliper for deciduous, 200cm height for coniferous.
- b. Maximize the use of large deciduous species wherever possible to maximize future canopy coverage
- c. Tree planting on city property shall be in accordance with the City of Ottawa's Tree Planting Specification; and include watering and warranty as described in the specification (can be provided by Forestry Services).
- d. Plant native trees whenever possible
- e. No root barriers, dead-man anchor systems, or planters are permitted.
- f. No tree stakes unless necessary (and only 1 on the prevailing winds side of the tree)

11. Hard surface planting

- a. Curb style planter is highly recommended
- b. No grates are to be used and if guards are required, City of Ottawa standard (which can be provided) shall be used.
- c. Trees are to be planted at grade

12. Soil Volume

- a. Please document on the LP that adequate soil volumes can be met:

Tree Type/Size	Single Tree Soil Volume (m3)	Multiple Tree Soil Volume (m3/tree)
Ornamental	15	9
Columnar	15	9
Small	20	12
Medium	25	15
Large	30	18
Conifer	25	15

*Please note that these soil volumes are not applicable in cases with Sensitive Marine Clay.

13. Sensitive Marine Clay

- a. Please follow the City's 2017 Tree Planting in Sensitive Marine Clay guidelines

14. Tree Canopy Cover

- a. The landscape plan shall show how the proposed tree planting will replace and increase canopy cover on the site over time, to support the City's 40% urban forest canopy cover target.
- b. At a site level, efforts shall be made to provide as much canopy cover as possible, through tree planting and tree retention, with an aim of 40% canopy cover at 40 years, as appropriate.
- c. Indicate on the plan the projected future canopy cover at 40 years for the site.

For additional information on the landscape plan tree planting requirements, please contact tracy.smith@Ottawa.ca.

City Surveyor

1. The determination of property boundaries, minimum setbacks and other regulatory constraints are a critical component of development. An Ontario Land Surveyor (O.L.S.) needs to be consulted at the outset of a project to ensure properties are properly defined and can be used as the geospatial framework for the development.
2. Topographic details may also be required for a project and should be either carried out by the O.L.S. that has provided the Legal Survey or done in consultation with the O.L.S. to ensure that the project is integrated to the appropriate control network.

Questions regarding the above requirements can be directed to the City's Surveyor, Bill Harper, at Bill.Harper@ottawa.ca

Rideau Valley Conservation Authority (RVCA)

The RVCA has no objections and the following comment:

1. Enhanced Water quality protection is demonstrated either through on-site controls or confirmation of water quality being achieved through downstream municipal infrastructure. Please include in the SWM report how water quality is being achieved.

Other

1. Plans are to be standard A1 size (594 mm x 841 mm) sheets, utilizing an appropriate Metric scale (1:200, 1:250, 1:300, 1:400 or 1:500).
2. All PDF submitted documents are to be unlocked and flattened.
3. You are encouraged to contact the Ward Councillor, Councillor Keith Egli, at Keith.Egli@ottawa.ca about the proposal.

METRIC
DISTANCES AND ELEVATIONS SHOWN ON THIS PLAN ARE IN METRES
AND CAN BE CONVERTED TO FEET BY DIVIDING BY 0.3048

**TOPOGRAPHIC PLAN OF
LOTS 2 AND 3
REGISTERED PLAN 564563
PART OF LOT 28 CONCESSION A (RF)
PART OF CLARKE ROAD &
PEDLEY STREET (AS CLOSE BY INST NP51189)
REGISTERED PLAN 382
PART OF LOTS 76, 77, 82, 93, 94,
95, 96 & 97
LOTS 78, 79, 80 & 81
REGISTERED PLAN 382
PART OF LOT 2
REGISTERED PLAN 459792
CITY OF OTTAWA**

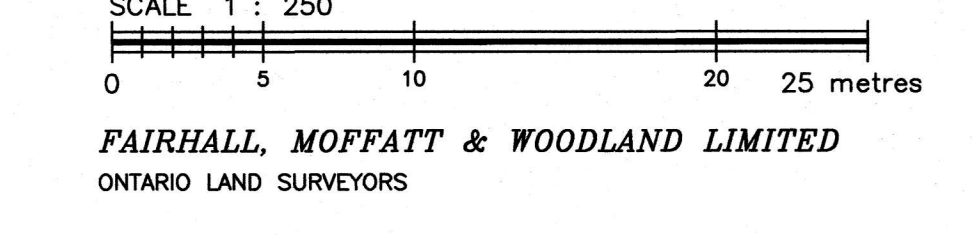

FAIRHALL, MOFFATT & WOODLAND LIMITED
ONTARIO LAND SURVEYORS

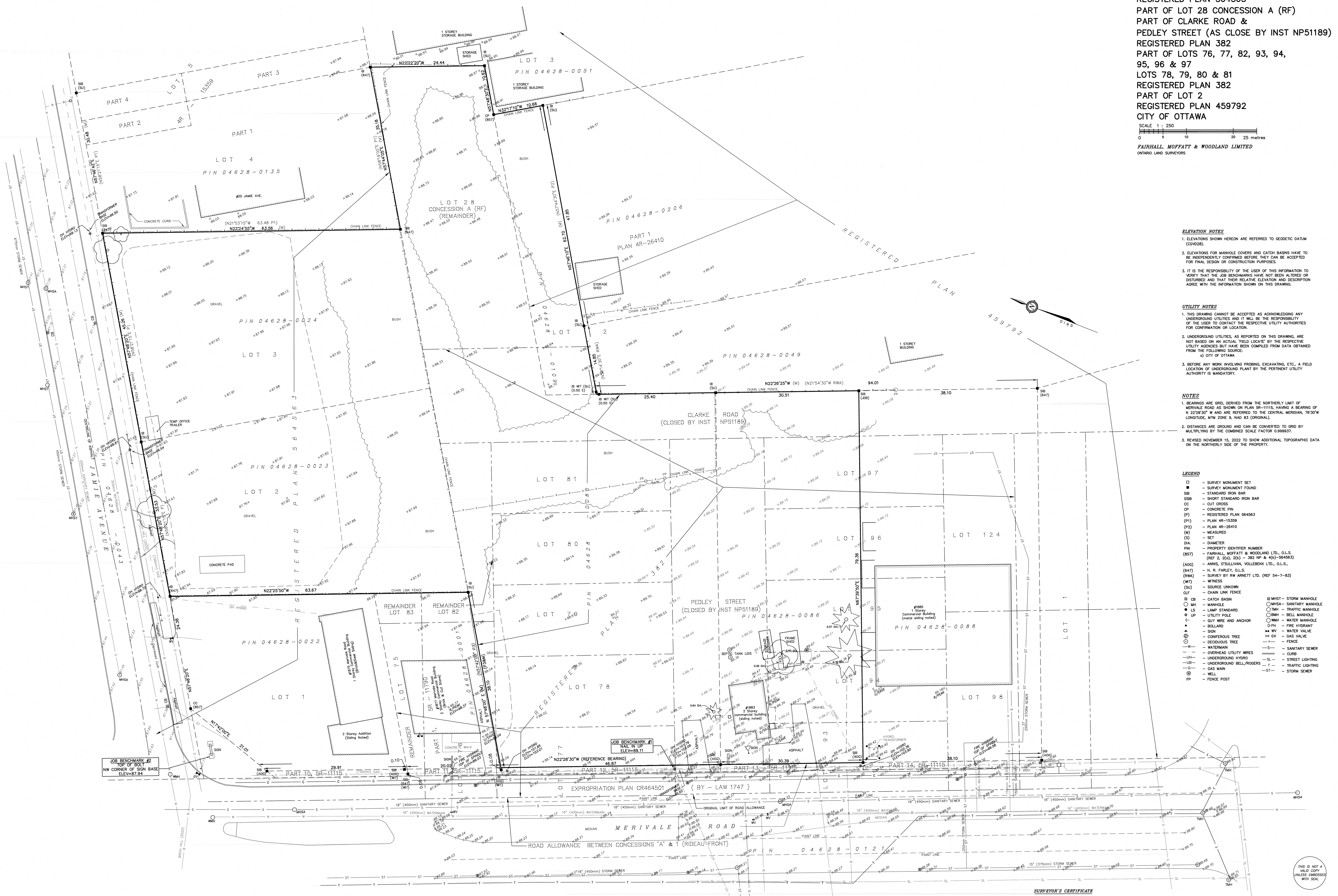

- ELEVATION NOTES**
- ELEVATIONS SHOWN HEREON ARE REFERRED TO GEODETIC DATUM (CGD028).
 - ELEVATIONS FOR MANHOLE COVERS AND CATCH BASINS HAVE TO BE INDEPENDENTLY CONFIRMED BEFORE THEY CAN BE ACCEPTED FOR FINAL DESIGN OR CONSTRUCTION PURPOSES.
 - IT IS THE RESPONSIBILITY OF THE USER OF THIS INFORMATION TO VERIFY THAT THE JOB BENCHMARKS HAVE NOT BEEN ALTERED OR DISTURBED AND THAT THEIR RELATIVE ELEVATION AND DESCRIPTION AGREE WITH THE INFORMATION SHOWN ON THIS DRAWING.

- UTILITY NOTES**
- THIS DRAWING CANNOT BE ACCEPTED AS ACKNOWLEDGING ANY UNDERGROUND UTILITIES AND IT WILL BE THE RESPONSIBILITY OF THE USER TO CONTACT THE RESPECTIVE UTILITY AUTHORITIES FOR CONFIRMATION OR LOCATION.
 - UNDERGROUND UTILITIES, AS REPORTED ON THIS DRAWING, ARE NOT BASED ON AN ACTUAL 'FIELD LOCATE' BY THE RESPECTIVE UTILITY AGENCIES BUT HAVE BEEN COMPILED FROM DATA OBTAINED FROM THE FOLLOWING SOURCE:
a) CITY OF OTTAWA
 - BEFORE ANY WORK INVOLVING PROBING, EXCAVATING, ETC., A FIELD LOCATION OF UNDERGROUND PLANT BY THE PERTINENT UTILITY AUTHORITY IS MANDATORY.

- NOTES**
- BEARINGS ARE GRID, DERIVED FROM THE NORTHERLY LIMIT OF MERIVALE ROAD AS SHOWN ON PLAN 50-11115, HAVING A BEARING OF N 22°28'30" W AND ARE REFERRED TO THE CENTRAL MERIDIAN, 76°30' W LONGITUDE, N.T.M. ZONE 9, NAD 83 (ORIGINAL).
 - DISTANCES ARE GROUND AND CAN BE CONVERTED TO GRID BY MULTIPLYING BY THE COMBINED SCALE FACTOR 0.999937.
 - REVISED NOVEMBER 15, 2022 TO SHOW ADDITIONAL TOPOGRAPHIC DATA ON THE NORTHERLY SIDE OF THE PROPERTY.

- LEGEND**
- | | | | |
|-------|--|---|------------------------|
| □ | - SURVEY MONUMENT SET | ○ | MSA - STORM MANHOLE |
| ■ | - SURVEY MONUMENT FOUND | ○ | MSA - SANITARY MANHOLE |
| SB | - STANDARD IRON BAR | ○ | TMH - TRAFFIC MANHOLE |
| SSB | - SHORT STANDARD IRON BAR | ○ | BMH - BELL MANHOLE |
| CC | - CUT CROSS | ○ | WMH - WATER MANHOLE |
| CP | - CONCRETE PIN | ○ | FMH - FIRE HYDRANT |
| (P) | - REGISTERED PLAN 564563 | ○ | FW - FIRE VALVE |
| (P1) | - PLAN 48-15359 | ○ | HW - WATER VALVE |
| (P2) | - PLAN 48-26410 | ○ | GV - GAS VALVE |
| (M) | - MEASURED | ○ | SL - STREET LIGHTING |
| (S) | - SET | ○ | ST - STORM SEWER |
| DA | - DIAMETER | ○ | |
| FIN | - PROPERTY IDENTIFIER NUMBER | ○ | |
| (857) | - FAIRHALL, MOFFATT & WOODLAND LTD., O.L.S. (REF 2-260-20) - 382 NP & 403-564943 | ○ | |
| (A00) | - ANNIS, O'SULLIVAN, VOLLEBEKE LTD., O.L.S. | ○ | |
| (847) | - H. R. FARLEY, O.L.S. | ○ | |
| (RWA) | - SURVEY BY RW ARNETT LTD. (REF 54-7-83) | ○ | |
| (WT) | - WITNESS | ○ | |
| (SU) | - SOURCE UNKNOWN | ○ | |
| CLF | - CHAIN LINK FENCE | ○ | |
| CB | - CATCH BASIN | ○ | |
| MH | - MANHOLE | ○ | |
| LS | - LAMP STANDARD | ○ | |
| UP | - UTILITY POLE | ○ | |
| W | - CITY WIRE AND ANCHOR | ○ | |
| B | - BOLLARD | ○ | |
| S | - SIGN | ○ | |
| CT | - CONIFEROUS TREE | ○ | |
| DT | - DECIDUOUS TREE | ○ | |
| W | - WATERMAIN | ○ | |
| OH | - OVERHEAD UTILITY WIRES | ○ | |
| UH | - UNDERGROUND HYDRO | ○ | |
| UB | - UNDERGROUND BELL/ROGERS | ○ | |
| G | - GAS MAIN | ○ | |
| M | - WELL | ○ | |
| FP | - FENCE POST | ○ | |

SURVEYOR'S CERTIFICATE

I CERTIFY THAT:
1. THIS SURVEY AND PLAN ARE CORRECT AND IN ACCORDANCE WITH THE SURVEYS ACT, THE SURVEYORS ACT, THE LAND TITLES ACT AND THE REGULATIONS MADE UNDER THEM.
2. THE SURVEY WAS COMPLETED ON OCTOBER 26, 2022.

John H. Guitri
DATE: _____
JOHN H. GUITRI
ONTARIO LAND SURVEYOR

**Fairhall
Moffatt &
Woodland**
ONTARIO LAND SURVEYORS

1111
Surveying and Land Information Services
100-200 TOWER SQUARE, SUITE 200, OTTAWA, ONTARIO K1Z 1R8
TEL: (613) 991-2200 FAX: (613) 991-1165

Job No. AC21300
E365796 - N5022030
REFERENCE No. H01 - 382 NP
S:\N5022030\N5022030\02213_topo.dwg (K0)

© COPYRIGHT 2022. REPRODUCTION, ALTERATION OR DISTRIBUTION OF THIS PLAN WITHOUT THE WRITTEN CONSENT OF FAIRHALL, MOFFATT & WOODLAND LIMITED IS PROHIBITED.

JAMIE AVENUE

MERIVALE ROAD

CENTRELINE OF MERIVALE ROAD

BUILDING B
PROPOSED
ONE-STOREY WAREHOUSE
3,070sm / 33,050sf

BUILDING A
PROPOSED
ONE-STOREY WAREHOUSE
3,540sm / 38,100sf

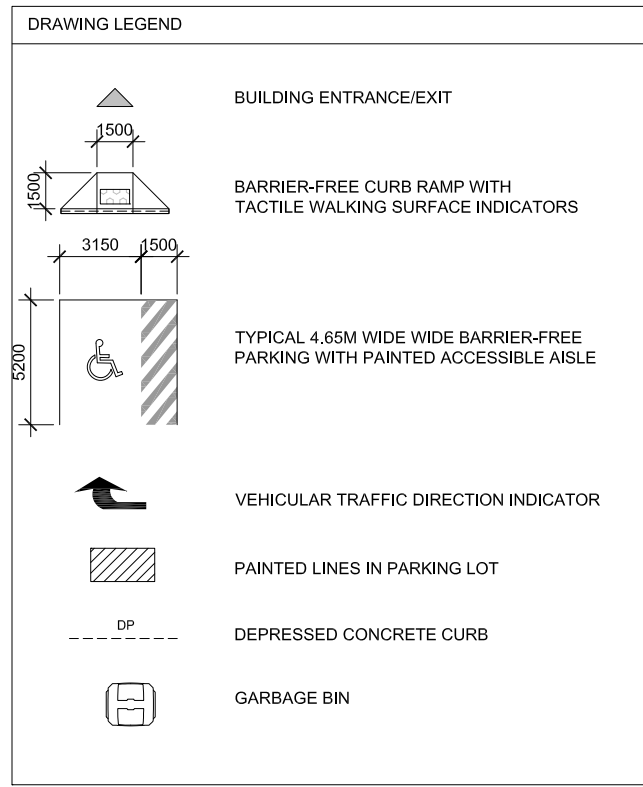
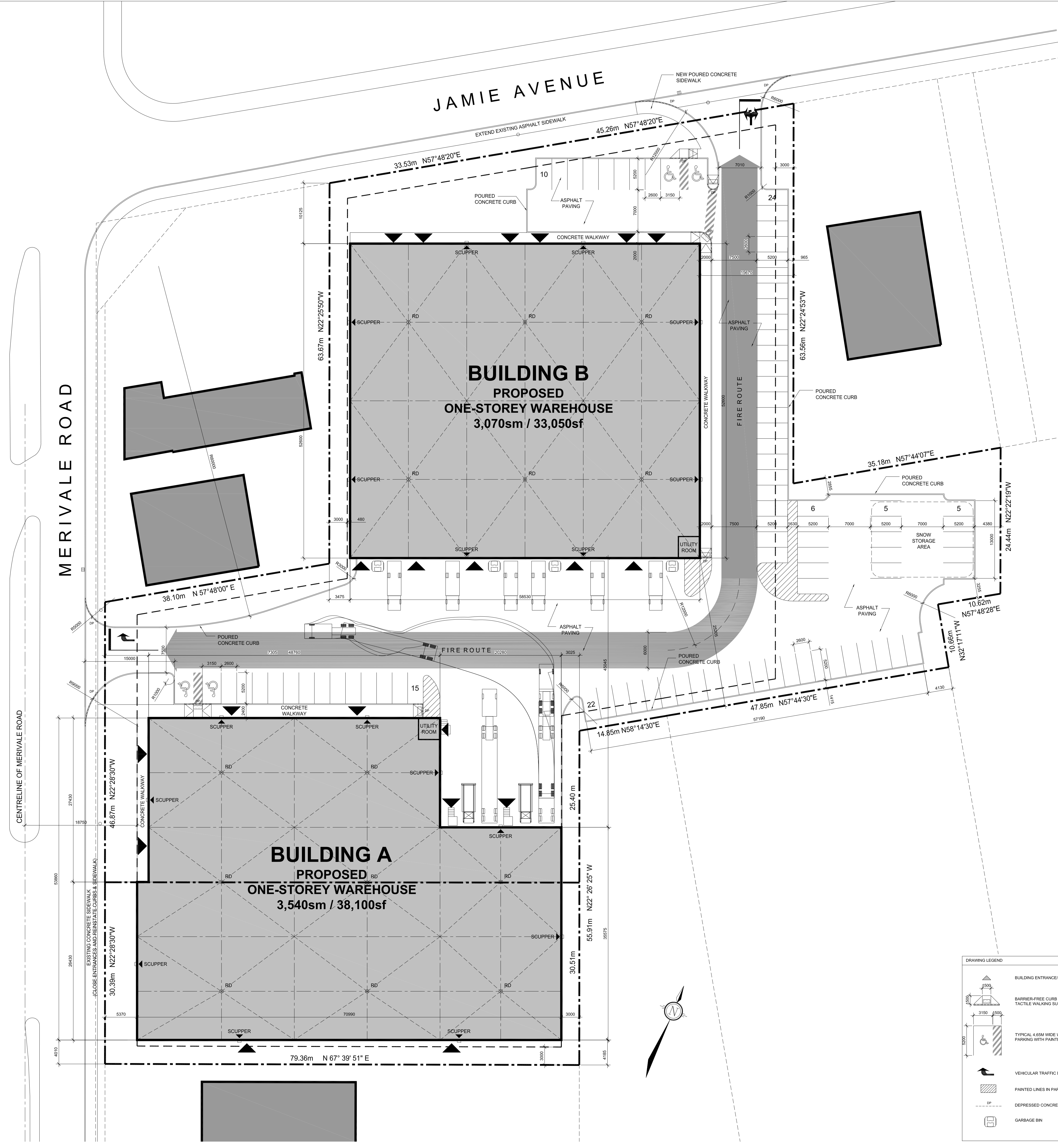

03 LOCATION PLAN
SP-A01 NTS

SITE INFORMATION

SITE AREA: 13,999 m²

BUILDING DATA:

AREA CALCULATIONS:

Gross Floor Area:	
Building A:	3,540sm (38,100sf)
Building B:	3,070sm (33,050sf)
Total:	6,610sm (71,150sf)

ZONING

DESIGNATION: IG - GENERAL INDUSTRIAL ZONE

PERMITTED NON RESIDENTIAL USES SECTION 199:

- Light Industrial Uses
- Medical Facility
- Office
- Parking Garage
- Parking Lot
- Research and Development Centre
- Service and Repair Shop
- Storage Yard
- Technology Industry
- Training Centre
- Warehouse

NOTE: Accessory display and sales areas within the same building must not exceed 25% of the gross floor area.

Uses Permitted up to 300sm each without exceeding 2,999sm total:

- Animal care establishment
- Automotive dealership or rental establishment
- Automotive service station gas bar or car wash
- Bank or bank machine
- Bar
- Convenience store
- Instructional facility
- Payday loan establishment
- Personal services business
- Post office
- Recreational and athletic facility
- Restaurant

FSI - TABLE 199:

Maximum Permitted:	2.0 (28,226sm / 303,820sf)
Provided:	0.5 (6,610sm / 71,150sf)

SETBACKS - TABLE 199:

Front & Corner Yard:	3.0m
Interior Side Yard:	3.0m
Rear Side Yard:	3.0m

BUILDING HEIGHT - TABLE 199:

Maximum Permitted:	22.0m
Provided:	8.5m

MINIMUM WIDTH OF LANDSCAPED AREA TABLE 199:

Abutting a Street:	3.0m
Abutting a Residential Zone:	3.0m
All Other Cases:	No minimum

PARKING Section 101

MINIMUM REQUIRED:	53
(WAREHOUSE .8/100sm OF GFA)	
PROVIDED:	87 (INCL. 4 BARR-FREE)



North

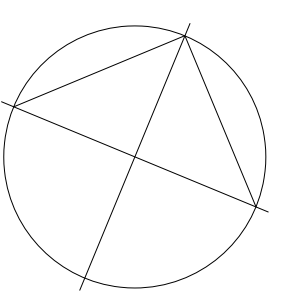

Revisions

No.	By	Description	Date
01	NH	ISSUED FOR COORDINATION	2022/09/09
02	NH	REV. FOR COORDINATION	2022/10/06
03	NH	REV. FOR COORDINATION	2022/12/08
04	NH	REV. FOR COORDINATION	2023/01/27

Project

**MERIVALE ROAD
INDUSTRIAL
DEVELOPMENT**

1881/1883 MERIVALE RD., Ottawa

Drawing

SITE PLAN

Scale AS NOTED Stamp

Drawn JAS

Checked

Project No.

19-120

Date

SEPT. 2022

Drawing No.

SP-A01

APPENDIX C
WATERMAIN CALCULATIONS

McINTOSH PERRY

000-23-1150 - 1881 Merivale - Water Demands

Project:	1881 Merivale
Project No.:	000-23-1150
Designed By:	RRR
Checked By:	AJG
Date:	January 12, 2023
Ste Area:	1.40 gross ha

<u>Residential</u>	NUMBER OF UNITS		UNIT RATE	
Single Family		homes	3.4	persons/unit
Semi-detached		homes	2.7	persons/unit
Townhouse		homes	2.7	persons/unit
Bachelor Apartment		units	1.4	persons/unit
1 Bedroom Apartment		units	1.4	persons/unit
2 Bedroom Apartment		units	2.1	persons/unit
3 Bedroom Apartment		units	3.1	persons/unit
Average Apartment		units	1.8	persons/unit

Total Population **0 persons**

<u>Commercial</u>	m2
<u>Industrial - Light</u>	13998 m2
<u>Industrial - Heavy</u>	m2

AVERAGE DAILY DEMAND

DEMAND TYPE	AMOUNT	UNITS	
Residential	280	L/c/d	
Industrial - Light	35,000	L/gross ha/d	
Industrial - Heavy	55,000	L/gross ha/d	
Shopping Centres	2,500	L/(1000m ² /d)	
Hospital	900	L/(bed/day)	
Schools	70	L/(Student/d)	
Trailer Park with no Hook-Ups	340	L/(space/d)	
Trailer Park with Hook-Ups	800	L/(space/d)	
Campgrounds	225	L/(campsite/d)	
Mobile Home Parks	1,000	L/(Space/d)	
Motels	150	L/(bed-space/d)	
Hotels	225	L/(bed-space/d)	
Tourist Commercial	28,000	L/gross ha/d	
Other Commercial	28,000	L/gross ha/d	
	Residential	0.00	L/s
AVERAGE DAILY DEMAND	Commercial/ Industrial/ Institutional	0.57	L/s

McINTOSH PERRY

MAXIMUM DAILY DEMAND

DEMAND TYPE	AMOUNT		UNITS
Residential	9.5	x avg. day	L/c/d
Industrial	1.5	x avg. day	L/gross ha/d
Commercial	1.5	x avg. day	L/gross ha/d
Institutional	1.5	x avg. day	L/gross ha/d
MAXIMUM DAILY DEMAND	Residential	0.00	L/s
	Commercial/ Industrial/ Institutional	0.85	L/s

MAXIMUM HOUR DEMAND

DEMAND TYPE	AMOUNT		UNITS
Residential	14.3	x avg. day	L/c/d
Industrial	1.8	x max. day	L/gross ha/d
Commercial	1.8	x max. day	L/gross ha/d
Institutional	1.8	x max. day	L/gross ha/d
MAXIMUM HOUR DEMAND	Residential	0.00	L/s
	Commercial/ Industrial/ Institutional	1.53	L/s

WATER DEMAND DESIGN FLOWS PER UNIT COUNT

CITY OF OTTAWA - WATER DISTRIBUTION GUIDELINES, JULY 2010

AVERAGE DAILY DEMAND	0.57	L/s
MAXIMUM DAILY DEMAND	0.85	L/s
MAXIMUM HOUR DEMAND	1.53	L/s

McINTOSH PERRY

000-23-1150 - 1881 Merivale - Fire Underwriters Survey Building A

Project: 1881 Merivale
 Project No.: 000-23-1150
 Designed By: RFR
 Checked By: AJG
 Date: January 12, 2023

From the Fire Underwriters Survey (2020)

From Part II – Guide for Determination of Required Fire Flow Copyright I.S.O.:
 City of Ottawa Technical Bulletin ISTB-2018-02 Applied Where Applicable

A. BASE REQUIREMENT (Rounded to the nearest 1000 L/min)

F = 220 x C x √A Where: F = Required fire flow in liters per minute
 C = Coefficient related to the type of construction.
 A = The total floor area in square meters (including all storey's, but excluding basements at least 50 percent below grade) in the building being considered.

Construction Type Ordinary Construction

C	1	A	3,540.0 m ²
Total Floor Area (per the 2020 FUS Page 20 - Total Effective Area)			3,540.0 m ² * Unprotected Vertical Openings

Calculated Fire Flow	13,089.5 L/min
	13,000.0 L/min

B. REDUCTION FOR OCCUPANCY TYPE (No Rounding)

From Page 24 of the Fire Underwriters Survey:
 Combustible 0%

Fire Flow	13,000.0 L/min
-----------	----------------

C. REDUCTION FOR SPRINKLER TYPE (No Rounding)

Fully Supervised Sprinklered -50%

Reduction	-6,500.0 L/min
-----------	----------------

D. INCREASE FOR EXPOSURE (No Rounding)

	Separation Distance (m)	Cons. of Exposed Wall	Length Exposed Adjacent Wall (m)	Height (Stories)	Length-Height Factor	
Exposure 1	20.1 to 30	Ordinary - Mass Timber (Protected)	60	1	60.0	0%
Exposure 2	20.1 to 30	Ordinary - Mass Timber (Unprotected)	30	2	60.0	2%
Exposure 3	3.1 to 10	Ordinary - Mass Timber (Protected)	28	1	28.0	4%
Exposure 4	Over 30 m	Wood frame	20	1	20.0	0%
					% Increase*	6%

Increase*	780.0 L/min
-----------	-------------

E. Total Fire Flow (Rounded to the Nearest 1000 L/min)

Fire Flow	7,280.0 L/min
Fire Flow Required**	7,000.0 L/min

* In accordance with Part II, Section 4, the Increase for separation distance is not to exceed 75%

** In accordance with Section 4 the Fire flow is not to exceed 45,000 L/min or be less than 2,000 L/min

McINTOSH PERRY

000-23-1150 - 1881 Merivale - Fire Underwriters Survey Building B

Project: 1881 Merivale
 Project No.: 000-23-1150
 Designed By: RFR
 Checked By: AJG
 Date: January 12, 2023

From the Fire Underwriters Survey (2020)

From Part II – Guide for Determination of Required Fire Flow Copyright I.S.O.:
 City of Ottawa Technical Bulletin ISTB-2018-02 Applied Where Applicable

A. BASE REQUIREMENT (Rounded to the nearest 1000 L/min)

F = 220 x C x vA Where: F = Required fire flow in liters per minute
 C = Coefficient related to the type of construction.
 A = The total floor area in square meters (including all storey's, but excluding basements at least 50 percent below grade) in the building being considered.

Construction Type Ordinary Construction

C 1 A 3,070.0 m²
 Total Floor Area (per the 2020 FUS Page 20 - Total Effective Area) 3,070.0 m² * Unprotected Vertical Openings

Calculated Fire Flow 12,189.7 L/min
 12,000.0 L/min

B. REDUCTION FOR OCCUPANCY TYPE (No Rounding)

From Page 24 of the Fire Underwriters Survey:
 Combustible 0%

Fire Flow 12,000.0 L/min

C. REDUCTION FOR SPRINKLER TYPE (No Rounding)

Fully Supervised Sprinklered -50%

Reduction -6,000.0 L/min

D. INCREASE FOR EXPOSURE (No Rounding)

	Separation Distance (m)	Cons. of Exposed Wall	Length Exposed Adjacent Wall (m)	Height (Stories)	Length-Height Factor	
Exposure 1	Over 30 m	Fire Resistive - Non Combustible (Unprotected Openings)	90	1	90.0	0%
Exposure 2	20.1 to 30	Ordinary - Mass Timber (Unprotected)	23	2	46.0	2%
Exposure 3	20.1 to 30	Ordinary - Mass Timber (Unprotected)	50	1	50.0	2%
Exposure 4	10.1 to 20	Ordinary - Mass Timber (Unprotected)	10	1	10.0	5%
					% Increase*	9%

Increase* 1,080.0 L/min

E. Total Fire Flow (Rounded to the Nearest 1000 L/min)

Fire Flow 7,080.0 L/min
 Fire Flow Required** 7,000.0 L/min

* In accordance with Part II, Section 4, the Increase for separation distance is not to exceed 75%

** In accordance with Section 4 the Fire flow is not to exceed 45,000 L/min or be less than 2,000 L/min

1881-1883 Building A Hydrant Coverage Figure

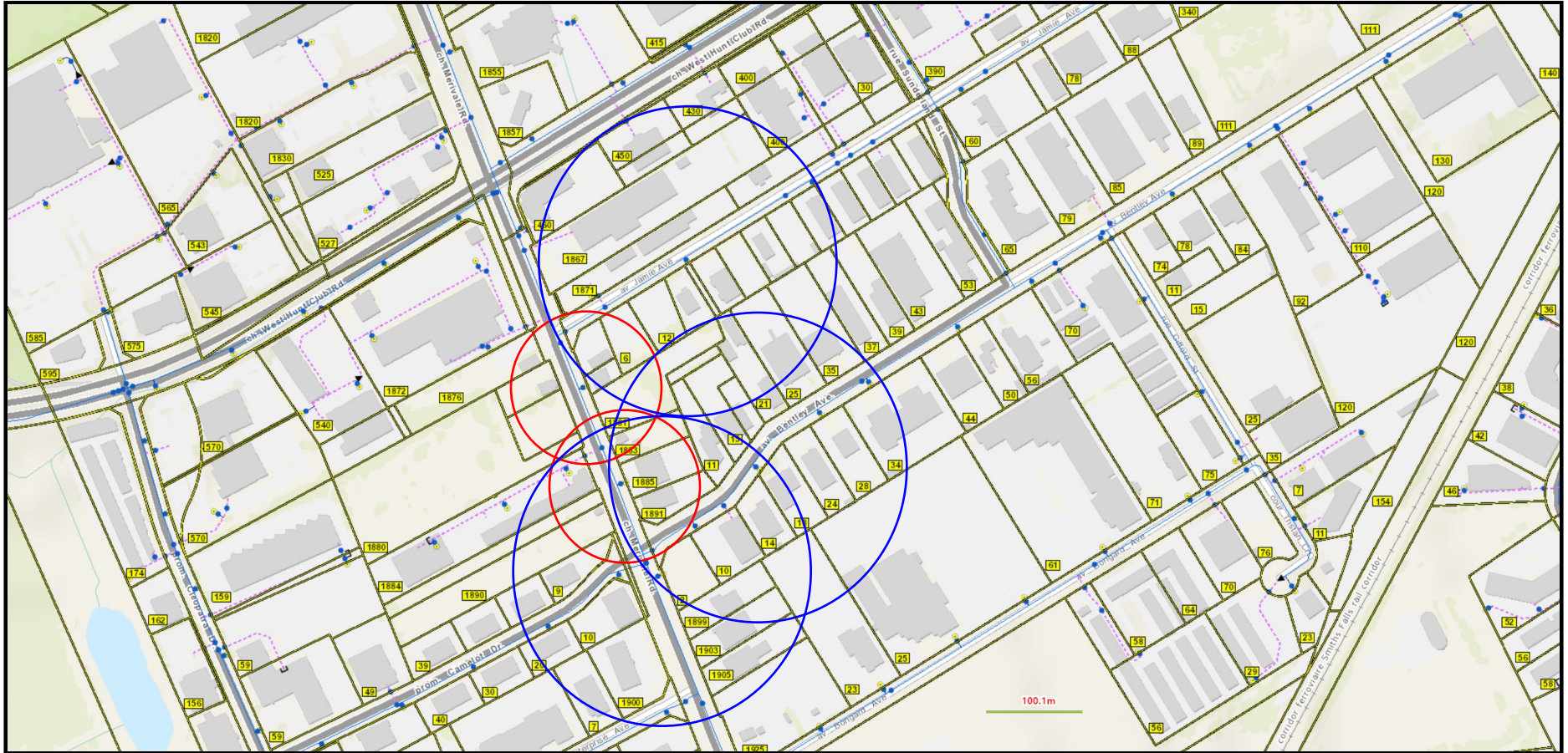

Hydrants Within 75m: 2

Hydrants Within 150m: 3

1881-1883 Building B Hydrant Coverage Figure

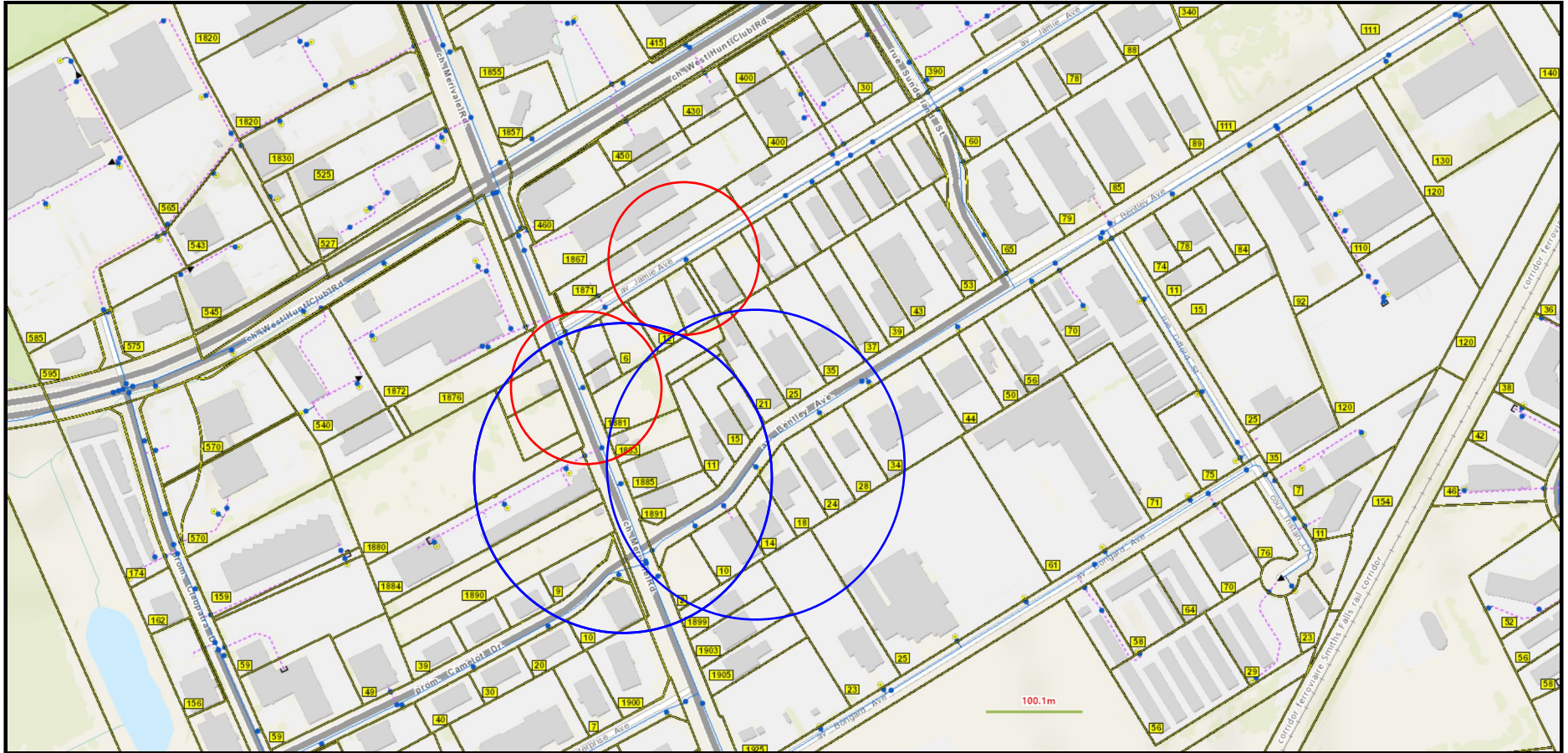

Hydrants Within 75m: 2

Hydrants Within 150m: 2

S.

ENERGY MINES & RESOURCES P.S.

1881 Merivale Road

2W2C

Approximate Site Location

BARRHAVEN P.S.

Merivale Rd. Backup P.S.

OTTAWA SOUTH

FALLOWFIELD RD. RES. & P.S.

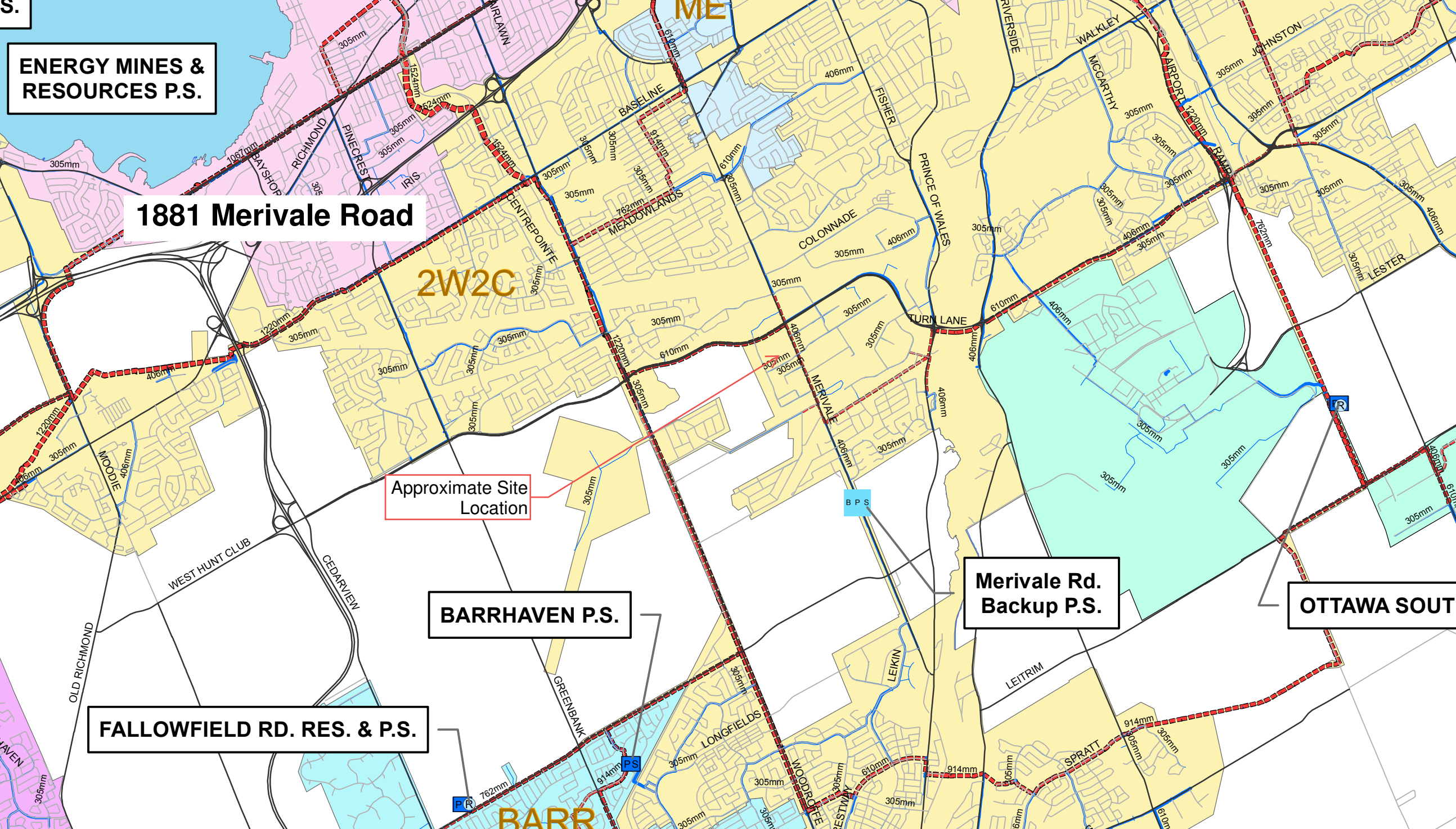

APPENDIX D
SANITARY CALCULATIONS

McINTOSH PERRY

000-23-1150 - 1881 Merivale - Sanitary Demands

Project:	1881 Merivale		
Project No.:	000-23-1150		
Designed By:	R.R.R.		
Checked By:	A.J.G.		
Date:	January 18, 2023		
Site Area	1.40	Gross ha	
Duplex	0	2.30	Persons per unit
Apartment	0	1.80	Persons per unit
Total Population	0	Persons	
Commercial Area	0.00	m ²	
Amenity Space	0.00	m ²	

DESIGN PARAMETERS

Institutional/ Commercial Peaking Factor	1.5	* Check technical bulleting (Either use 1.0 or 1.5)
Residential Peaking Factor	3.80	* Using Harmon Formula = $1+(14/(4+P^{0.5})) * 0.8$ where P = population in thousands, Harmon's Correction Factor = 0.8
Mannings coefficient (n)	0.013	
Demand (per capita)	280	L/day
Infiltration allowance	0.33	L/s/Ha

EXTRANEOUS FLOW ALLOWANCES

Infiltration / Inflow	Flow (L/s)
Dry	0.07
Wet	0.39
Total	0.46

AVERAGE DAILY DEMAND

DEMAND TYPE	AMOUNT	UNITS	POPULATION / AREA	Flow (L/s)
Residential	280	L/c/d	0	0.00
Industrial - Light**	35,000	L/gross ha/d	1.40	0.57
Industrial - Heavy**	55,000	L/gross ha/d		0
Commercial / Amenity	2,800	L/(1000m ² /d)	0.00	0.00
Hospital	900	L/(bed/day)		0
Schools	70	L/(Student/d)		0
Trailer Parks no Hook-Ups	340	L/(space/d)		0
Trailer Park with Hook-Ups	800	L/(space/d)		0
Campgrounds	225	L/(campsite/d)		0
Mobile Home Parks	1,000	L/(Space/d)		0
Motels	150	L/(bed-space/d)		0
Hotels	225	L/(bed-space/d)		0
Office	75	L/7.0m ² /d		0
Tourist Commercial	28,000	L/gross ha/d		0
Other Commercial	28,000	L/gross ha/d		0

McINTOSH PERRY

AVERAGE RESIDENTIAL FLOW	0.00	L/s
PEAK RESIDENTIAL FLOW	0.00	L/s
AVERAGE ICI FLOW	0.00	L/s
PEAK INSTITUTIONAL/ COMMERCIAL FLOW	0.00	L/s
PEAK INDUSTRIAL FLOW	3.57	L/s
TOTAL PEAK ICI FLOW	3.57	L/s

TOTAL SANITARY DEMAND

TOTAL ESTIMATED AVERAGE DRY WEATHER FLOW	0.07	L/s
TOTAL ESTIMATED PEAK DRY WEATHER FLOW	3.64	L/s
TOTAL ESTIMATED PEAK WET WEATHER FLOW	4.03	L/s

** PEAK INDUSTRIAL FLOW PER CITY OF OTTAWA SEWER DESIGN GUIDELINES APPENDIX 4B

SANITARY SEWER DESIGN SHEET

PROJECT: CCO-23-1150
 LOCATION: 1881-1883 Merivale



LOCATION				RESIDENTIAL								ICI AREAS						INFILTRATION ALLOWANCE			FLOW		SEWER DATA								
1	2	3	4	5	6	7	8	9	10	11	12	13	14	15	16	17	18	19	20	21	22	23	24	25	26	27	28	29	30	31	
STREET	AREA ID	FROM MH	TO MH	UNIT TYPES				AREA (ha)	POPULATION		PEAK FACTOR	PEAK FLOW (L/s)	AREA (ha)						PEAK FLOW (L/s)	AREA (ha)		FLOW (L/s)	DESIGN FLOW (L/s)	CAPACITY (L/s)	LENGTH (m)	DIA (mm)	SLOPE (%)	VELOCITY (full) (m/s)	AVAILABLE CAPACITY		
				SF	SD	TH	APT		IND	CUM			INSTITUTIONAL	COMMERCIAL	INDUSTRIAL		IND	CUM		IND	CUM								IND	CUM	L/s
Jamie Avenue		MH1A	MH1B					0.00	0.0	0.0	3.80	0.00		0.00		0.00	1.40	1.40	3.57	1.40	1.40	0.46	4.03	8.99	52.05	150	0.32	0.493	4.95	55.11	
		MH1B	MHSA18556					0.00	0.0	0.0	3.80	0.00		0.00		0.00	1.40	1.40	3.57	0.00	1.40	0.46	4.03	8.99	96.10	150	0.32	0.493	4.95	55.11	
Design Parameters:				Notes:								Designed: FFR						No.		Revision						Date					
Residential				ICI Areas								Checked: FDF						1.													
SF	3.4	p/p/u																													
TH/SD	2.7	p/p/u		INST	28,000	L/Ha/day																									
APT	2.3	p/p/u		COM	28,000	L/Ha/day																									
Other	60	p/p/Ha		IND	35,000	L/Ha/day																									
				* Per City of Ottawa SDG Appendix 4B								Project No.: CCO-23-1150								Sheet No: 1 of 1											

APPENDIX 4-B

PEAKING FACTOR FOR INDUSTRIAL AREAS

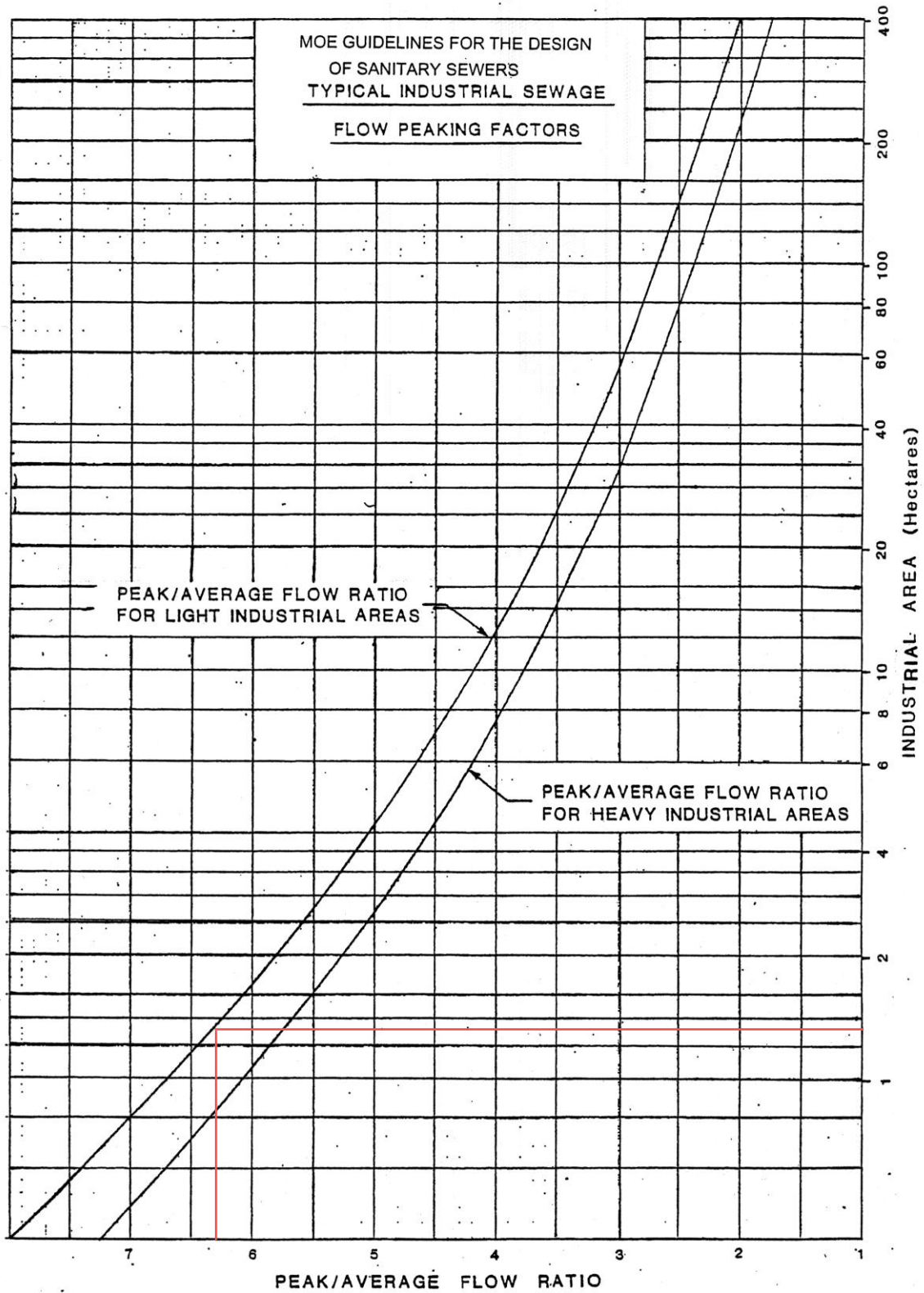

1881 Merivale Road

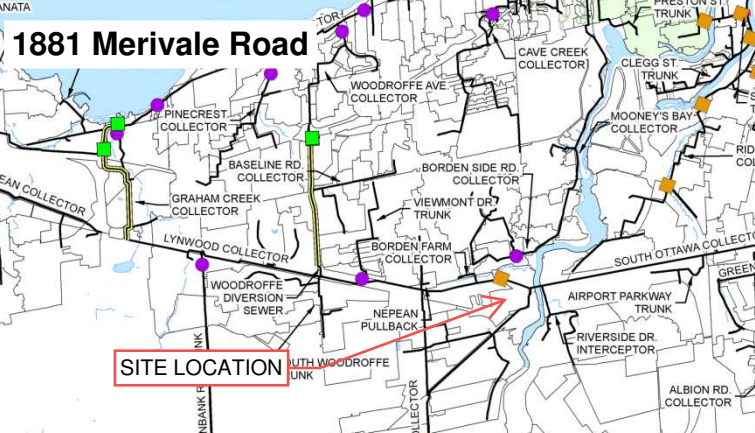

SITE LOCATION

APPENDIX E
PRE-DEVELOPMENT DRAINAGE PLAN

FILENAME: I:\Infrastructure\2023\CCO-23-1150\Area Dev\1881 Merivale Road\12 - Drainage\CCO-23-1150_Presentation.dwg
 DATE PLOTTED: Monday, February 13, 2023 1:51:58 PM
 USER: R.R.R.



GENERAL NOTES

1. THE ORIGINAL TOPOGRAPHY, GROUND ELEVATION AND SURVEY DATA SHOWN ARE SUPPLIED FOR INFORMATION PURPOSES ONLY, AND IMPLY NO GUARANTEE OF ACCURACY. IT SHALL BE THE RESPONSIBILITY OF THE CONTRACTOR TO VERIFY ALL INFORMATION SHOWN.
2. THIS PLAN IS NOT A CADASTRAL SURVEY SHOWING LEGAL PROPERTY BOUNDARIES AND EASEMENTS. THE PROPERTY BOUNDARIES SHOWN HEREON HAVE BEEN DERIVED INFORMATION SUPPLIED BY FAIRHALL MOFFATT & WOODLAND LTD. (JOB NO. AC21300) AND CANNOT BE RELIED UPON TO BE ACCURATE OR COMPLETE. THE PRECISE LOCATION OF THE CURRENT PROPERTY BOUNDARIES AND EASEMENTS CAN ONLY BE DETERMINED BY AN UP-TO-DATE LAND TITLES SEARCH AND A SUBSEQUENT CADASTRAL SURVEY PERFORMED AND CERTIFIED BY AN ONTARIO LAND SURVEYOR.
3. THE CONTRACTOR IS TO OBTAIN AND PAY FOR ALL NECESSARY PERMITS AND APPROVALS FROM THE CITY BEFORE COMMENCING CONSTRUCTION.
4. THE CONTRACTOR IS RESPONSIBLE FOR ALL LAZYT.
5. THE CONTRACTOR IS TO DETERMINE THE EXACT LOCATION, SIZE, MATERIAL AND ELEVATION OF ALL EXISTING UTILITIES PRIOR TO COMMENCING CONSTRUCTION. PROTECT AND ASSUME ALL RESPONSIBILITY FOR EXISTING UTILITIES WHETHER OR NOT SHOWN ON THESE DRAWINGS. IF THERE IS ANY DISCREPANCY THE CONTRACTOR IS TO NOTIFY THE ENGINEER PROMPTLY.
6. RESTORE ALL TRENCHES AND SURFACES OF PUBLIC ROAD ALLOWANCES TO CONDITION EQUAL OR BETTER THAN ORIGINAL CONDITION AND TO THE SATISFACTION OF THE CITY AUTHORITIES.
7. EXCAVATE AND DISPOSE OF ALL EXCESS EXCAVATED MATERIAL, SUCH AS ASPHALT, CURBING AND DEBRIS, OFF SITE AS DIRECTED BY THE ENGINEER AND THE CITY.
8. ALL DISTURBED AREAS TO BE RESTORED TO ORIGINAL CONDITION OR BETTER UNLESS OTHERWISE SPECIFIED.
9. THE CONTRACTOR SHALL BE RESPONSIBLE FOR ALL TRAFFIC CONTROL AND SAFETY MEASURES DURING THE CONSTRUCTION PERIOD, INCLUDING THE SUPPLY, INSTALLATION, AND REMOVAL OF ALL NECESSARY SIGNAGE, DELINEATORS, MARKERS AND BARRIERS.
10. DO NOT ALTER GRADING OF THE SITE WITHOUT PRIOR APPROVAL OF THE ENGINEER/CITY.
11. ALL ROADWAY, PARKING LOT, AND GRADING WORKS TO BE UNDERTAKEN IN ACCORDANCE WITH CITY STANDARDS AND SPECIFICATIONS. THE CONTRACTOR IS TO PROVIDE POSITIVE DRAINAGE AWAY FROM THE BUILDING.
12. CONTACT THE CITY FOR INSPECTION OF ROUGH GRADING OF PARKING LOTS, ROADWAYS AND LANDSCAPED AREAS PRIOR TO PLACEMENT OF ASPHALT AND TOPSOIL. ALL DEFICIENCIES NOTED SHALL BE RECTIFIED TO THE CITY'S SATISFACTION PRIOR TO PLACEMENT OF ANY ASPHALT, TOPSOIL, SEED & MULCH AND/OR SOD.
13. ALL DIMENSIONS AND INVERTS MUST BE VERIFIED PRIOR TO CONSTRUCTION, IF THERE IS ANY DISCREPANCY THE CONTRACTOR IS TO NOTIFY THE ENGINEER PROMPTLY.
14. ELECTRICAL, GAS, TELEPHONE AND TELEVISION SERVICE LOCATIONS ARE SUBJECT TO THE INDIVIDUAL AGENCY:
 - ELECTRICAL SERVICE - HYDRO OTTAWA,
 - GAS SERVICE - ENBRIDGE,
 - TELEPHONE SERVICE - BELL CANADA,
 - TELEVISION SERVICE - ROGERS.
15. INSTALLATION TO BE IN ACCORDANCE WITH CURRENT CODES AND STANDARDS OF APPROVAL AGENCIES HYDRO OTTAWA, BELL AND THE CITY.
16. CONTRACTOR TO ENSURE ALL APPLICABLE OPS SPECIFICATIONS ARE FOLLOWED DURING CONSTRUCTION
17. ALL PROPOSED CURB TO BE CONCRETE BARRIER CURB UNLESS OTHERWISE SPECIFIED.
18. THIS PLAN MUST BE READ IN CONJUNCTION WITH THE GEOTECHNICAL INVESTIGATION COMPLETED BY BY ARCADIS, DATED JANUARY 29, 2023



LEGEND

--- PROPERTY LINE	- - - CENTRELINE OF SWALE
DC BARRIER CURB & CURB DEPRESSION	- - - CENTRELINE OF DITCH
PROPOSED HEAVY DUTY ASPHALT	SLOPING AT 3:1 UNLESS SPECIFIED
PROPOSED CONCRETE WALKWAY	PROPOSED ELEVATION EXISTING ELEVATION
MH# STORM MANHOLE	SWALE ELEVATION
CB CATCHBASIN, CURB INLET OR DITCH INLET	TOP/BOTTOM WALL FACE ELEVATIONS
MH#A SANITARY MANHOLE	EMERGENCY OVERLAND FLOW ROUTE
PERFORATED PIPE	SILT FENCE BARRIER PER OPSD 219.110
WATER VALVE/CHAMBER	BUILDING ENTRANCE OVERHEAD DOOR REDUCER
FIRE HYDRANT	LOCATION OF TWSP PER ARCHITECTURAL
PROPOSED WALL	LOCATION OF SIAMESE CONNECTION
SEDIMENT CONTROL DEVICE PER DETAIL	RD LOCATION OF ROOF DRAIN
ROADCUT AND REINSTATEMENT PER CITY	SC LOCATION OF SCUPPER
SERVICE/WATERMAIN BEND	
SERVICE/SEWER CROSSING LOCATION	

FOR REVIEW ONLY
NOT FOR CONSTRUCTION

1	ISSUED FOR SITE PLAN CONTROL	FEB 13, 2023
No.	Revisions	Date

Check and verify all dimensions before proceeding with the work. Do not scale drawings.

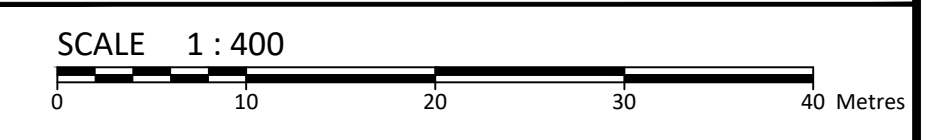

McINTOSH PERRY
 115 Walgreen Road, RR3, Carp, ON K0A 1L0
 Tel: 613-836-2184 Fax: 613-836-3742
 www.mcintoshperry.com

Client: **Z.V. HOLDINGS CORP.**
1801 WOODWARD DRIVE OTTAWA, ON K2C 0R3

Project: **WAREHOUSE DEVELOPMENT**
1881 MERIVALE ROAD

Stamp:

Ottawa, ON

Drawing Title: **PRE-DEVELOPMENT DRAINAGE PLAN**

Scale: 1:400	Project Number: CCO-23-1150
Drawn By: R.R.R.	
Checked By: R.D.F.	
Designed By: R.R.R.	

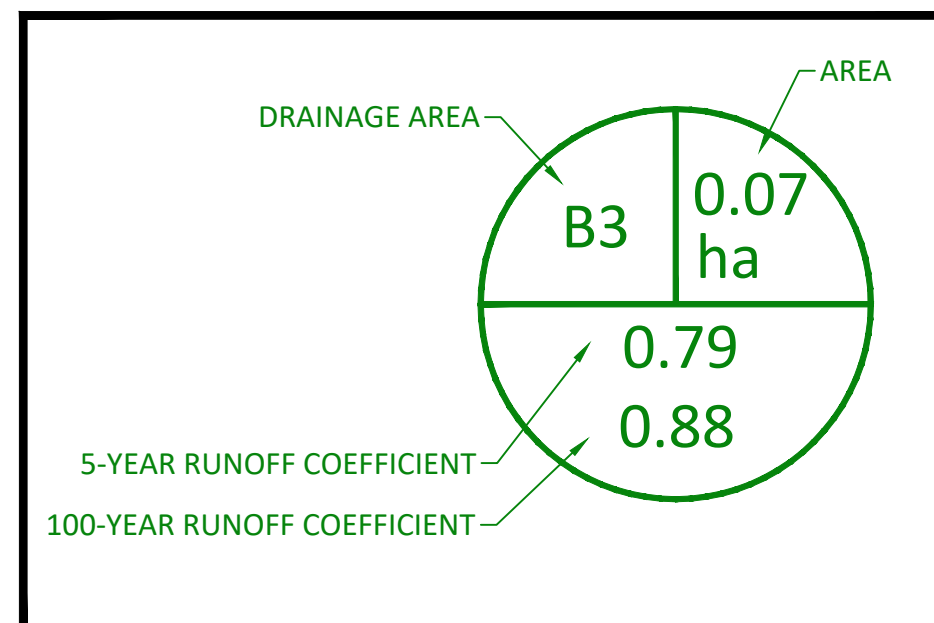

D07-12-XX-XXXX

APPENDIX F
POST-DEVELOPMENT DRAINAGE PLAN

FILENAME: I:\Infrastructure\2023\CCO-23-1150\Area Dev\1881 Merivale Road\12 - Drainage\CCO-23-1150_Presentation.dwg
 LAST SAVED: Monday, February 13, 2023 1:51:54 PM BY: r.robman
 LAST PLOTTED: Monday, February 13, 2023 1:51:54 PM

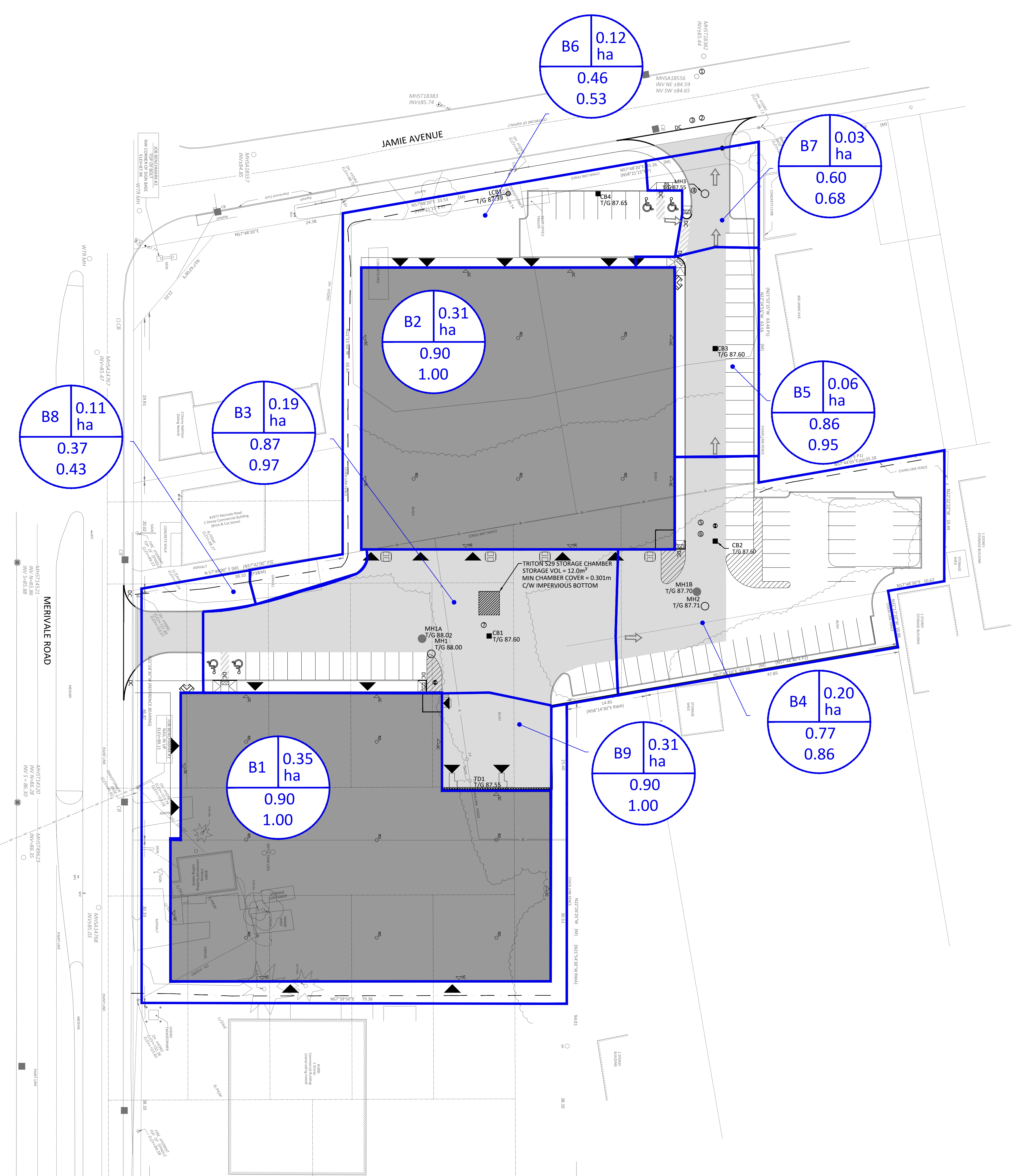

GENERAL NOTES

1. THE ORIGINAL TOPOGRAPHY, GROUND ELEVATION AND SURVEY DATA SHOWN ARE SUPPLIED FOR INFORMATION PURPOSES ONLY, AND IMPLY NO GUARANTEE OF ACCURACY. IT SHALL BE THE RESPONSIBILITY OF THE CONTRACTOR TO VERIFY ALL INFORMATION SHOWN.
2. THIS PLAN IS NOT A CADASTRAL SURVEY SHOWING LEGAL PROPERTY BOUNDARIES AND EASEMENTS. THE PROPERTY BOUNDARIES SHOWN HEREON HAVE BEEN DERIVED FROM INFORMATION SUPPLIED BY FAIRHALL MOFFATT & WOODLAND LTD. (JOB NO. AC21300) AND CANNOT BE RELIED UPON TO BE ACCURATE OR COMPLETE. THE PRECISE LOCATION OF THE CURRENT PROPERTY BOUNDARIES AND EASEMENTS CAN ONLY BE DETERMINED BY AN UP-TO-DATE LAND TITLES SEARCH AND A SUBSEQUENT CADASTRAL SURVEY PERFORMED AND CERTIFIED BY AN ONTARIO LAND SURVEYOR.
3. THE CONTRACTOR IS TO OBTAIN AND PAY FOR ALL NECESSARY PERMITS AND APPROVALS FROM THE CITY BEFORE COMMENCING CONSTRUCTION.
4. THE CONTRACTOR IS RESPONSIBLE FOR ALL LAZOUT.
5. THE CONTRACTOR IS TO DETERMINE THE EXACT LOCATION, SIZE, MATERIAL AND ELEVATION OF ALL EXISTING UTILITIES PRIOR TO COMMENCING CONSTRUCTION. PROTECT AND ASSUME ALL RESPONSIBILITY FOR EXISTING UTILITIES WHETHER OR NOT SHOWN ON THESE DRAWINGS. IF THERE IS ANY DISCREPANCY THE CONTRACTOR IS TO NOTIFY THE ENGINEER PROMPTLY.
6. RESTORE ALL TRENCHES AND SURFACES OF PUBLIC ROAD ALLOWANCES TO CONDITION EQUAL OR BETTER THAN ORIGINAL CONDITION AND TO THE SATISFACTION OF THE CITY AUTHORITIES.
7. EXCAVATE AND DISPOSE OF ALL EXCESS EXCAVATED MATERIAL, SUCH AS ASPHALT, CURBING AND DEBRIS, OFF SITE AS DIRECTED BY THE ENGINEER AND THE CITY.
8. ALL DISTURBED AREAS TO BE RESTORED TO ORIGINAL CONDITION OR BETTER UNLESS OTHERWISE SPECIFIED.
9. THE CONTRACTOR SHALL BE RESPONSIBLE FOR ALL TRAFFIC CONTROL AND SAFETY MEASURES DURING THE CONSTRUCTION PERIOD, INCLUDING THE SUPPLY, INSTALLATION, AND REMOVAL OF ALL NECESSARY SIGNAGE, DELINEATORS, MARKERS AND BARRIERS.
10. DO NOT ALTER GRADING OF THE SITE WITHOUT PRIOR APPROVAL OF THE ENGINEER/CITY.
11. ALL ROADWAY, PARKING LOT, AND GRADING WORKS TO BE UNDERTAKEN IN ACCORDANCE WITH CITY STANDARDS AND SPECIFICATIONS. THE CONTRACTOR IS TO PROVIDE POSITIVE DRAINAGE AWAY FROM THE BUILDING.
12. CONTACT THE CITY FOR INSPECTION OF ROUGH GRADING OF PARKING LOTS, ROADWAYS AND LANDSCAPED AREAS PRIOR TO PLACEMENT OF ASPHALT AND TOPSOIL. ALL DEFICIENCIES NOTED SHALL BE RECTIFIED TO THE CITY'S SATISFACTION PRIOR TO PLACEMENT OF ANY ASPHALT, TOPSOIL, SEED & MULCH AND/OR SOD.
13. ALL DIMENSIONS AND INVERTS MUST BE VERIFIED PRIOR TO CONSTRUCTION, IF THERE IS ANY DISCREPANCY THE CONTRACTOR IS TO NOTIFY THE ENGINEER PROMPTLY.
14. ELECTRICAL, GAS, TELEPHONE AND TELEVISION SERVICE LOCATIONS ARE SUBJECT TO THE INDIVIDUAL AGENCY:
 - ELECTRICAL SERVICE - HYDRO OTTAWA,
 - GAS SERVICE - ENBRIDGE,
 - TELEPHONE SERVICE - BELL CANADA,
 - TELEVISION SERVICE - ROGERS.
16. INSTALLATION TO BE IN ACCORDANCE WITH CURRENT CODES AND STANDARDS OF APPROVAL AGENCIES HYDRO OTTAWA, BELL AND THE CITY.
17. CONTRACTOR TO ENSURE ALL APPLICABLE OPS SPECIFICATIONS ARE FOLLOWED DURING CONSTRUCTION
18. ALL PROPOSED CURB TO BE CONCRETE BARRIER CURB UNLESS OTHERWISE SPECIFIED.
19. THIS PLAN MUST BE READ IN CONJUNCTION WITH THE GEOTECHNICAL INVESTIGATION COMPLETED BY BY ARCADIS, DATED JANUARY 29, 2023



LEGEND

--- PROPERTY LINE	- - - CENTRELINE OF SWALE
DC BARRIER CURB & CURB DEPRESSION	- - - CENTRELINE OF DITCH
PROPOSED HEAVY DUTY ASPHALT	SLOPING AT 3:1 UNLESS SPECIFIED
PROPOSED CONCRETE WALKWAY	PROPOSED ELEVATION EXISTING ELEVATION
MH# STORM MANHOLE	95.94 SWALE ELEVATION
CB CATCHBASIN, CURB INLET OR DITCH INLET	95.94 TOP/BOTTOM WALL FACE ELEVATIONS
MH#A SANITARY MANHOLE	1/100.50 EMERGENCY OVERLAND FLOW ROUTE
PERFORATED PIPE	SILT FENCE BARRIER PER OPSD 219.110
WATER VALVE/CHAMBER	BUILDING ENTRANCE OVERHEAD DOOR
FIRE HYDRANT	REDUCER
PROPOSED WALL	LOCATION OF TWSI PER ARCHITECTURAL
SEDIMENT CONTROL DEVICE PER DETAIL	LOCATION OF SIAMSESE CONNECTION
ROADCUT AND REINSTATEMENT PER CITY R10	RD LOCATION OF ROOF DRAIN
SERVICE/WATERMAIN SERVICE	SC LOCATION OF SCUPPER
SERVICE/SEWER CROSSING LOCATION	

FOR REVIEW ONLY
 NOT FOR CONSTRUCTION

1	ISSUED FOR SITE PLAN CONTROL	FEB 13, 2023
No.	Revisions	Date

Check and verify all dimensions before proceeding with the work Do not scale drawings

SCALE 1:400

McINTOSH PERRY
 115 Walgreen Road, RR3, Carp, ON K0A 1L0
 Tel: 613-836-2184 Fax: 613-836-3742
 www.mcintoshperry.com

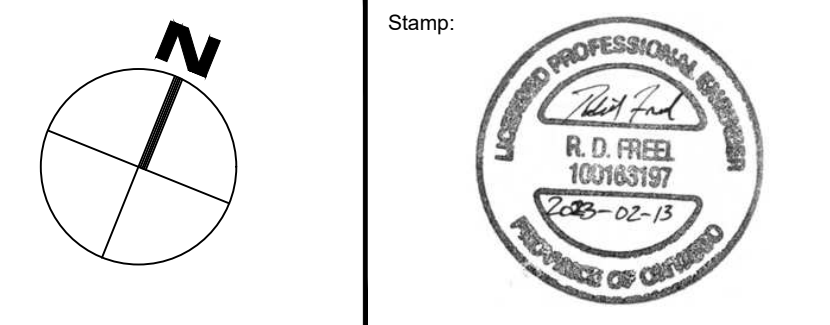

Client: **Z.V. HOLDINGS CORP.**
 1801 WOODWARD DRIVE
 OTTAWA, ON K2C 0R3

Project: **WAREHOUSE DEVELOPMENT**
 1881 MERIVALE ROAD

OTTAWA ON

Drawing Title: **POST-DEVELOPMENT DRAINAGE PLAN**

Scale: 1:400	Project Number: CCO-23-1150
Drawn By: R.R.R.	
Checked By: R.D.F.	
Designed By: R.R.R.	

POST

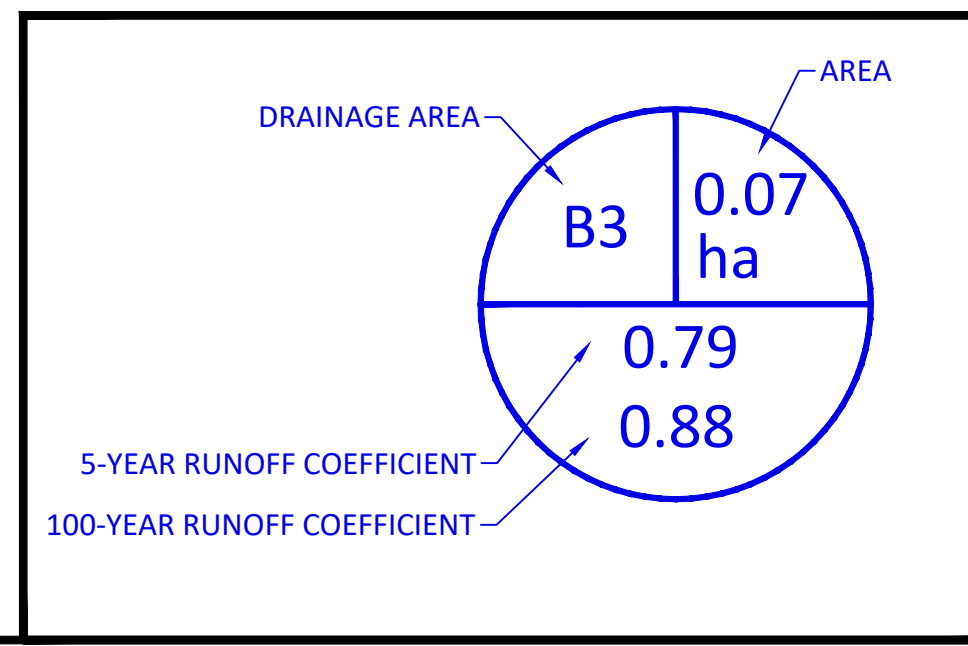

D07-12-XX-XXXX

APPENDIX G
STORMWATER MANAGEMENT CALCULATIONS

McINTOSH PERRY

CO-23-1150 - 1881-1883 Merivale - SWM Calculations

1 of 12

Tc (min)	Intensity (mm/hr)		
	5-Year	100-Year	
17	76.9	131.3	PRE-DEVELOPMENT
10	104.2	178.6	POST-DEVELOPMENT

C-Values	
Impervious	0.90
Gravel	0.70
Pervious	0.20

Pre-Development Runoff Coefficient

Drainage Area	Impervious Area (m ²)	Gravel (m ²)	Pervious Area (m ²)	Average C (5-year)	Average C (100-year)
A1	219	3,126	10,651	0.32	0.40

Pre-Development Runoff Calculations

Drainage Area	Area (ha)	C 5-Year	C 100-Year	Tc (min)	Q (L/s)	
					5-Year	100-Year
A1	1.40	0.32	0.40	17	96.48	205.08
Total	1.40				96.48	205.08

Post-Development Runoff Coefficient

Drainage Area	Impervious Area (m ²)	Gravel (m ²)	Pervious Area (m ²)	Average C (5-year)	Average C (100-year)
B1	3,540	0	0	0.90	1.00
B2	3,070	0	0	0.90	1.00
B3	1,819	0	78	0.87	0.97
B4	1,649	0	393	0.77	0.86
B5	565	0	39	0.86	0.95
B6	462	0	759	0.46	0.53
B7	181	0	133	0.60	0.68
B8	270	0	842	0.37	0.43
B9	200	0	0	0.90	1.00

Post-Development Runoff Calculations

Drainage Area	Area (ha)	C 5-Year	C 100-Year	Tc (min)	Q (L/s)	
					5-Year	100-Year
B1	0.35	0.90	1.00	10	92.28	175.72
B2	0.31	0.90	1.00	10	80.03	152.39
B3	0.19	0.87	0.97	10	47.87	91.26
B4	0.20	0.77	0.86	10	45.27	86.74
B5	0.06	0.86	0.95	10	14.95	28.53
B6	0.12	0.46	0.53	10	16.43	32.33
B7	0.03	0.60	0.68	10	5.49	10.63
B8	0.11	0.37	0.43	10	11.92	23.85
B9	0.02	0.90	1.00	10	5.22	9.94
Total	1.40				319.46	611.39

McINTOSH PERRY

Required Restricted Flow

Drainage Area	Area (ha)	C 5-Year	Tc (min)	Q (L/s)
				5-Year
A1	1.40	0.32	17	96.48
Total				96.48

Post-Development Restricted Runoff Calculations

Drainage Area	Unrestricted Flow (L/S)		Restricted Flow (L/S)		Storage Required (m ³)		Storage Provided (m ³)	
	5-year	100-Year	5-Year	100-Year	5-Year	100-Year	5-Year	100-Year
B1	92.28	175.72	2.52	2.52	108.41	237.61	119.48	238.95
B2	80.03	152.39	1.89	1.89	98.09	213.93	103.61	218.74
B3	47.87	91.26	27.10	28.48	12.46	40.10	12.92	40.14
B4	45.27	86.74	9.50	10.00	25.44	63.63	25.88	66.23
B5	14.95	28.53	1.94	1.98	10.57	25.10	11.71	26.61
B6	16.43	32.33	2.00	2.10	11.93	29.09	12.28	31.90
B7	5.49	10.63	5.49	10.63				
B8	11.92	23.85	11.92	23.85				
B9	5.22	9.94	5.22	9.94				
Total	319.46	611.39	67.58	91.40	266.91	609.46	285.88	622.57

McINTOSH PERRY

CO-23-1150 - 1881-1883 Merivale - SWM Calculations

3 of 12

Storage Requirements for Area B1

5-Year Storm Event

Tc (min)	I (mm/hr)	Runoff (L/s) B1	Allowable Outflow (L/s)	Runoff to be Stored (L/s)	Storage Required (m ³)
130	18.3	16.21	2.52	13.68	106.74
140	17.3	15.32	2.52	12.80	107.51
150	16.4	14.53	2.52	12.00	108.01
160	15.6	13.82	2.52	11.29	108.41
170	14.8	13.11	2.52	10.58	107.96

Maximum Storage Required 5-year = 108 m³

100-Year Storm Event

Tc (min)	I (mm/hr)	Runoff (L/s) B1	Allowable Outflow (L/s)	Runoff to be Stored (L/s)	Storage Required (m ³)
290	16.3	16.04	2.52	13.52	235.20
300	15.9	15.65	2.52	13.12	236.22
310	15.5	15.25	2.52	12.73	236.78
320	15.1	14.86	2.52	12.34	236.86
330	14.7	14.47	2.52	11.94	236.46
340	14.4	14.17	2.52	11.65	237.61
350	14.0	13.78	2.52	11.25	236.33
360	13.7	13.48	2.52	10.96	236.70
370	13.4	13.19	2.52	10.66	236.72
380	13.1	12.89	2.52	10.37	236.39

Maximum Storage Required 100-year = 238 m³

5-Year Storm Event Storage Summary

Roof Storage			
Location	Area*	Depth	Volume (m ³)
Roof	2655.00	0.045	119.48

Storage Available (m³) = 119.48
Storage Required (m³) = 108.41

100-Year Storm Event Storage Summary

Roof Storage			
Location	Area*	Depth	Volume (m ³)
Roof	2655.00	0.090	238.95

Storage Available (m³) = 238.95
Storage Required (m³) = 237.61

* Area is 75% of the total roof area

McINTOSH PERRY

Roof Drain Flow (B1)

Roof Drains Summary		
Type of Control Device	Watts Drainage - Accutrol Weir	
Number of Roof Drains	8	
	5-Year	100-Year
Rooftop Storage (m ³)	119.48	238.95
Storage Depth (m)	0.045	0.090
Flow (Per Roof Drain) (L/s)	0.32	0.32
Total Flow (L/s)	2.52	2.52

Flow Rate Vs. Build-Up (One Weir Fully Closed)	
Depth (mm)	Flow (L/s)
15	0.18
20	0.24
25	0.30
30	0.32
35	0.32
40	0.32
45	0.32
50	0.32
55	0.32

* Roof Drain model to be Accutrol Weirs, See attached sheets
 * Roof Drain Flow information taken from Watts Drainage website

CALCULATING ROOF FLOW EXAMPLES

1 roof drain during a 5 year storm
 elevation of water = 25mm
 Flow leaving 1 roof drain = (1 x 0.30 L/s) = 0.30 L/s

1 roof drain during a 100 year storm
 elevation of water = 50mm
 Flow leaving 1 roof drain = (1 x 0.60 L/s) = 0.60 L/s

4 roof drains during a 5 year storm
 elevation of water = 25mm
 Flow leaving 4 roof drains = (4 x 0.30 L/s) = 1.20 L/s

4 roof drains during a 100 year storm
 elevation of water = 50mm
 Flow leaving 4 roof drains = (4 x 0.60 L/s) = 2.40 L/s

Roof Drain Flow		
Flow (l/s)	Storage Depth (mm)	Drains Flow (l/s)
0.18	15	1.44
0.24	20	1.92
0.30	25	2.40
0.32	30	2.52
0.32	35	2.52
0.32	40	2.52
0.32	45	2.52
0.32	50	2.52
0.32	55	2.52
0.32	60	2.52
0.32	65	2.52
0.32	70	2.52
0.32	75	2.52
0.32	80	2.52
0.32	85	2.52
0.32	90	2.52
0.32	95	2.52
0.32	100	2.52
0.32	105	2.52
0.32	110	2.52
0.32	115	2.52
0.32	120	2.52
0.32	125	2.52
0.32	130	2.52
0.32	135	2.52
0.32	140	2.52
0.32	145	2.52
0.32	150	2.52

Note: The flow leaving through a restricted roof drain is based on flow vs. head information

McINTOSH PERRY

CO-23-1150 - 1881-1883 Merivale - SWM Calculations

5 of 12

Storage Requirements for Area B2

5-Year Storm Event

Tc (min)	I (mm/hr)	Runoff (L/s) B2	Allowable Outflow (L/s)	Runoff to be Stored (L/s)	Storage Required (m ³)
200	13.0	9.99	1.89	8.09	97.11
210	12.6	9.68	1.89	7.79	98.09
220	12.1	9.29	1.89	7.40	97.70
230	11.7	8.99	1.89	7.09	97.90
240	11.3	8.68	1.89	6.79	97.73

Maximum Storage Required 5-year = 98 m³

100-Year Storm Event

Tc (min)	I (mm/hr)	Runoff (L/s) B2	Allowable Outflow (L/s)	Runoff to be Stored (L/s)	Storage Required (m ³)
400	12.6	10.75	1.89	8.86	212.65
410	12.4	10.58	1.89	8.69	213.77
420	12.1	10.33	1.89	8.43	212.53
430	11.9	10.16	1.89	8.26	213.19
440	11.7	9.99	1.89	8.09	213.64
450	11.5	9.81	1.89	7.92	213.89
460	11.3	9.64	1.89	7.75	213.93
470	11.1	9.47	1.89	7.58	213.77
480	10.9	9.30	1.89	7.41	213.40
490	10.7	9.13	1.89	7.24	212.83

Maximum Storage Required 100-year = 214 m³

5-Year Storm Event Storage Summary

Roof Storage			
Location	Area*	Depth	Volume (m ³)
Roof	2302.50	0.045	103.61

Storage Available (m³) = 103.61
Storage Required (m³) = 98.09

100-Year Storm Event Storage Summary

Roof Storage			
Location	Area*	Depth	Volume (m ³)
Roof	2302.50	0.095	218.74

Storage Available (m³) = 218.74
Storage Required (m³) = 213.93

* Area is 75% of the total roof area

McINTOSH PERRY

Roof Drain Flow (B2)

Roof Drains Summary		
Type of Control Device	Watts Drainage - Accutrol Weir	
Number of Roof Drains	6	
	5-Year	100-Year
Rooftop Storage (m ³)	119.48	238.95
Storage Depth (m)	0.045	0.095
Flow (Per Roof Drain) (L/s)	0.32	0.32
Total Flow (L/s)	1.89	1.89

Flow Rate Vs. Build-Up (One Weir Fully Closed)	
Depth (mm)	Flow (L/s)
15	0.18
20	0.24
25	0.30
30	0.32
35	0.32
40	0.32
45	0.32
50	0.32
55	0.32

* Roof Drain model to be Accutrol Weirs, See attached sheets
 * Roof Drain Flow information taken from Watts Drainage website

CALCULATING ROOF FLOW EXAMPLES

1 roof drain during a 5 year storm
 elevation of water = 25mm
 Flow leaving 1 roof drain = (1 x 0.30 L/s) = 0.30 L/s

1 roof drain during a 100 year storm
 elevation of water = 50mm
 Flow leaving 1 roof drain = (1 x 0.60 L/s) = 0.60 L/s

4 roof drains during a 5 year storm
 elevation of water = 25mm
 Flow leaving 4 roof drains = (4 x 0.30 L/s) = 1.20 L/s

4 roof drains during a 100 year storm
 elevation of water = 50mm
 Flow leaving 4 roof drains = (4 x 0.60 L/s) = 2.40 L/s

Roof Drain Flow		
Flow (l/s)	Storage Depth (mm)	Drains Flow (l/s)
0.18	15	1.08
0.24	20	1.44
0.30	25	1.80
0.32	30	1.89
0.32	35	1.89
0.32	40	1.89
0.32	45	1.89
0.32	50	1.89
0.32	55	1.89
0.32	60	1.89
0.32	65	1.89
0.32	70	1.89
0.32	75	1.89
0.32	80	1.89
0.32	85	1.89
0.32	90	1.89
0.32	95	1.89
0.32	100	1.89
0.32	105	1.89
0.32	110	1.89
0.32	115	1.89
0.32	120	1.89
0.32	125	1.89
0.32	130	1.89
0.32	135	1.89
0.32	140	1.89
0.32	145	1.89
0.32	150	1.89

Note: The flow leaving through a restricted roof drain is based on flow vs. head information

McINTOSH PERRY

CO-23-1150 - 1881-1883 Merivale - SWM Calculations

7 of 12

Storage Requirements for Area B3

5-Year Storm Event

Tc (min)	I (mm/hr)	Runoff (L/s) B3	Allowable Outflow (L/s)	Runoff to be Stored (L/s)	Storage Required (m ³)
5	141.2	64.87	27.10	37.77	11.33
10	104.2	47.87	27.10	20.77	12.46
15	83.6	38.41	27.10	11.31	10.18
20	70.3	32.30	27.10	5.20	6.24
25	60.9	27.98	27.10	0.88	1.32

Maximum Storage Required 5-year = 12 m³

100-Year Storm Event

Tc (min)	I (mm/hr)	Runoff (L/s) B3	Allowable Outflow (L/s)	Runoff to be Stored (L/s)	Storage Required (m ³)
10	178.6	91.28	28.48	62.80	37.68
15	142.9	73.04	28.48	44.56	40.10
20	120.0	61.33	28.48	32.85	39.42
25	103.8	53.05	28.48	24.57	36.86
30	91.9	46.97	28.48	18.49	33.28
35	82.6	42.22	28.48	13.74	28.85
40	75.1	38.38	28.48	9.90	23.77
45	69.1	35.32	28.48	6.84	18.46
50	64.0	32.71	28.48	4.23	12.69
55	59.6	30.46	28.48	1.98	6.54

Maximum Storage Required 100-year = 40 m³

5-Year Storm Event Storage Summary

		Water Elev. (m) = 87.68	
Location	T/G	INV. (out)	Depth (m)
S29	N/A	86.21	N/A
CB1	87.60	86.19	0.08

Storage Available (m³) = 12.9
Storage Required (m³) = 12.5 *

100-Year Storm Event Storage Summary

		Water Elev. (m) = 87.85	
Location	T/G	INV. (out)	Depth (m)
S29	N/A	86.21	N/A
CB1	87.60	86.19	0.25

Storage Available (m³) = 40.1
Storage Required (m³) = 40.1 *

* Available Storage calculated from AutoCAD

McINTOSH PERRY

CO-23-1150 - 1881-1883 Merivale - SWM Calculations

For Orifice Flow, C= 0.60
 For Weir Flow, C= 1.84

8 of 12

	Orifice 1	Orifice 2	Weir 1	Weir 2
invert elevation	86.01	X	96.00	X
center of crest elevation	86.06	X		X
orifice width / weir length	101 mm	X	0.48 m	X
weir height				X
orifice area (m ²)	0.008	X	x	X

Elevation Discharge Table - Storm Routing

Elevation	Orifice 1		Orifice 2		Weir 1		Weir 2		Total Q [L/s]
	H [m]	Q [m ³ /s]	H [m]	Q [m ³ /s]	H [m]	Q [m ³ /s]	H [m]	Q [m ³ /s]	
87.60	1.54	0.026	x	x	x	x	x	x	26.42
87.61	1.55	0.03	x	x	x	x	x	x	26.51
87.62	1.56	0.03	x	x	x	x	x	x	26.59
87.63	1.57	0.03	x	x	x	x	x	x	26.68
87.64	1.58	0.03	x	x	x	x	x	x	26.76
87.65	1.59	0.03	x	x	x	x	x	x	26.85
87.66	1.60	0.03	x	x	x	x	x	x	26.93
87.67	1.61	0.03	x	x	x	x	x	x	27.01
87.68	1.62	0.03	x	x	x	x	x	x	27.10
87.69	1.63	0.03	x	x	x	x	x	x	27.18
87.70	1.64	0.03	x	x	x	x	x	x	27.26
87.71	1.65	0.03	x	x	x	x	x	x	27.35
87.72	1.66	0.03	x	x	x	x	x	x	27.43
87.73	1.67	0.03	x	x	x	x	x	x	27.51
87.74	1.68	0.03	x	x	x	x	x	x	27.59
87.75	1.69	0.03	x	x	x	x	x	x	27.68
87.76	1.70	0.03	x	x	x	x	x	x	27.76
87.77	1.71	0.03	x	x	x	x	x	x	27.84
87.78	1.72	0.03	x	x	x	x	x	x	27.92
87.79	1.73	0.03	x	x	x	x	x	x	28.00
87.80	1.74	0.03	x	x	x	x	x	x	28.08
87.81	1.75	0.03	x	x	x	x	x	x	28.16
87.82	1.76	0.03	x	x	x	x	x	x	28.24
87.83	1.77	0.03	x	x	x	x	x	x	28.32
87.84	1.78	0.03	x	x	x	x	x	x	28.40
87.85	1.79	0.03	x	x	x	x	x	x	28.48
87.86	1.80	0.03	x	x	x	x	x	x	28.56

5-Year

100-Year

- Notes:
1. For Orifice Flow, User is to Input an Elevation Higher than Crown of Orifice.
 2. Orifice Equation: $Q = cA(2gh)^{1/2}$
 3. Weir Equation: $Q = CLH^{3/2}$
 4. These Computations Do Not Account for Submergence Effects Within the Pond Riser.
 5. H for orifice equations is depth of water above the centroid of the orifice.
 6. H for weir equations is depth of water above the weir crest.

McINTOSH PERRY

CO-23-1150 - 1881-1883 Merivale - SWM Calculations

9 of 12

Storage Requirements for Area B4

5-Year Storm Event

Tc (min)	I (mm/hr)	Runoff (L/s) B4	Allowable Outflow (L/s)	Runoff to be Stored (L/s)	Storage Required (m ³)
15	83.6	36.32	9.50	26.82	24.14
20	70.3	30.54	9.50	21.04	25.25
25	60.9	26.46	9.50	16.96	25.44
30	53.9	23.42	9.50	13.92	25.05
35	48.5	21.07	9.50	11.57	24.30

Maximum Storage Required 5-year = 25 m³

100-Year Storm Event

Tc (min)	I (mm/hr)	Runoff (L/s) B4	Allowable Outflow (L/s)	Runoff to be Stored (L/s)	Storage Required (m ³)
10	178.6	86.76	10.00	76.76	46.05
15	142.9	69.42	10.00	59.42	53.47
20	120.0	58.29	10.00	48.29	57.95
25	103.8	50.42	10.00	40.42	60.63
30	91.9	44.64	10.00	34.64	62.36
35	82.6	40.12	10.00	30.12	63.26
40	75.1	36.48	10.00	26.48	63.55
45	69.1	33.57	10.00	23.57	63.63
50	64.0	31.09	10.00	21.09	63.27
55	59.6	28.95	10.00	18.95	62.54

Maximum Storage Required 100-year = 64 m³

5-Year Storm Event Storage Summary

		Water Elev. (m) = 87.77	
Location	T/G	INV. (out)	Depth (m)
CB2	87.60	85.99	0.17

Storage Available (m³) = 25.9
Storage Required (m³) = 25.4

100-Year Storm Event Storage Summary

		Water Elev. (m) = 87.84	
Location	T/G	INV. (out)	Depth (m)
CB2	87.60	85.99	0.24

Storage Available (m³) = 66.2
Storage Required (m³) = 63.6

* Available Storage calculated from AutoCAD

McINTOSH PERRY

CO-23-1150 - 1881-1883 Merivale - SWM Calculations

10 of 12

Storage Requirements for Area B5

5-Year Storm Event

Tc (min)	I (mm/hr)	Runoff (L/s) B5	Allowable Outflow (L/s)	Runoff to be Stored (L/s)	Storage Required (m ³)
30	53.9	7.74	1.94	5.80	10.43
35	48.5	6.96	1.94	5.02	10.54
40	44.2	6.34	1.94	4.40	10.57
45	40.6	5.83	1.94	3.89	10.49
50	37.7	5.41	1.94	3.47	10.41

Maximum Storage Required 5-year = 11 m³

100-Year Storm Event

Tc (min)	I (mm/hr)	Runoff (L/s) B5	Allowable Outflow (L/s)	Runoff to be Stored (L/s)	Storage Required (m ³)
40	75.1	12.00	1.98	10.02	24.04
45	69.1	11.04	1.98	9.06	24.46
50	64.0	10.23	1.98	8.25	24.74
55	59.6	9.52	1.98	7.54	24.89
60	55.9	8.93	1.98	6.95	25.02
65	52.6	8.40	1.98	6.42	25.05
70	49.8	7.96	1.98	5.98	25.10
75	47.3	7.56	1.98	5.58	25.10
80	45.0	7.19	1.98	5.21	25.01
85	43.0	6.87	1.98	4.89	24.94

Maximum Storage Required 100-year = 25 m³

5-Year Storm Event Storage Summary

		Water Elev. (m) =		87.74
Location	T/G	INV. (out)	Depth (m)	Volume (m ³)
CB3	87.60	85.99	0.14	11.7

Storage Available (m³) = 11.7 *
Storage Required (m³) = 10.6

100-Year Storm Event Storage Summary

		Water Elev. (m) =		87.79
Location	T/G	INV. (out)	Depth (m)	Volume (m ³)
CB3	87.60	85.99	0.19	26.6

Storage Available (m³) = 26.6 *
Storage Required (m³) = 25.1

* Available Storage calculated from AutoCAD

McINTOSH PERRY

CO-23-1150 - 1881-1883 Merivale - SWM Calculations

11 of 12

Storage Requirements for Area B6

5-Year Storm Event

Tc (min)	I (mm/hr)	Runoff (L/s) B6	Allowable Outflow (L/s)	Runoff to be Stored (L/s)	Storage Required (m ³)
35	48.5	7.65	2.00	5.65	11.86
40	44.2	6.97	2.00	4.97	11.93
45	40.6	6.40	2.00	4.40	11.89
50	37.7	5.94	2.00	3.94	11.83
55	35.1	5.53	2.00	3.53	11.67

Maximum Storage Required 5-year = 12 m³

100-Year Storm Event

Tc (min)	I (mm/hr)	Runoff (L/s) B6	Allowable Outflow (L/s)	Runoff to be Stored (L/s)	Storage Required (m ³)
50	64.0	11.59	2.10	9.49	28.47
55	59.6	10.79	2.10	8.69	28.68
60	55.9	10.12	2.10	8.02	28.88
65	52.6	9.52	2.10	7.42	28.95
70	49.8	9.02	2.10	6.92	29.05
75	47.3	8.56	2.10	6.46	29.09
80	45.0	8.15	2.10	6.05	29.03
85	43.0	7.79	2.10	5.69	29.00
90	41.1	7.44	2.10	5.34	28.85
95	39.4	7.13	2.10	5.03	28.69

Maximum Storage Required 100-year = 29 m³

5-Year Storm Event Storage Summary

		Water Elev. (m) = 87.59	
Location	T/G	INV. (out)	Depth (m)
LCB1	87.39	86.30	0.20
CB4	87.65	86.20	N/A

Storage Available (m³) = 12.3
Storage Required (m³) = 11.9 *

100-Year Storm Event Storage Summary

		Water Elev. (m) = 87.67	
Location	T/G	INV. (out)	Depth (m)
LCB1	87.39	86.30	0.28
CB4	87.65	86.20	0.02

Storage Available (m³) = 31.9
Storage Required (m³) = 29.1 *

* Available Storage calculated from AutoCAD

McINTOSH PERRY

CO-23-1150 - 1881-1883 Merivale - SWM Calculations

12 of 12

Time of Concentration Pre-Development

Drainage Area ID	Sheet Flow Distance (m)	Slope of Land (%)	Tc (min) (5-Year)	Tc (min) (100-Year)
A1	61	1.50	17	16

Therefore, a Tc of 10 can be used

$$T_c = (3.26(1.1-c)L^{0.5}/S^{0.33})$$

c = Balanced Runoff Coefficient

L = Length of drainage area

S = Average slope of watershed



Adjustable Accutrol Weir

Tag: _____

Adjustable Flow Control for Roof Drains

ADJUSTABLE ACCUTROL (for Large Sump Roof Drains only)

For more flexibility in controlling flow with heads deeper than 2", Watts Drainage offers the Adjustable Accutrol. The Adjustable Accutrol Weir is designed with a single parabolic opening that can be covered to restrict flow above 2" of head to less than 5 gpm per inch, up to 6" of head. To adjust the flow rate for depths over 2" of head, set the slot in the adjustable upper cone according to the flow rate required. Refer to Table 1 below.
 Note: Flow rates are directly proportional to the amount of weir opening that is exposed.

EXAMPLE:

For example, if the adjustable upper cone is set to cover 1/2 of the weir opening, flow rates above 2" of head will be restricted to 2-1/2 gpm per inch of head.

Therefore, at 3" of head, the flow rate through the Accutrol Weir that has 1/2 the slot exposed will be:
 [5 gpm (per inch of head) x 2 inches of head] + 2-1/2 gpm (for the third inch of head) = 12-1/2 gpm.

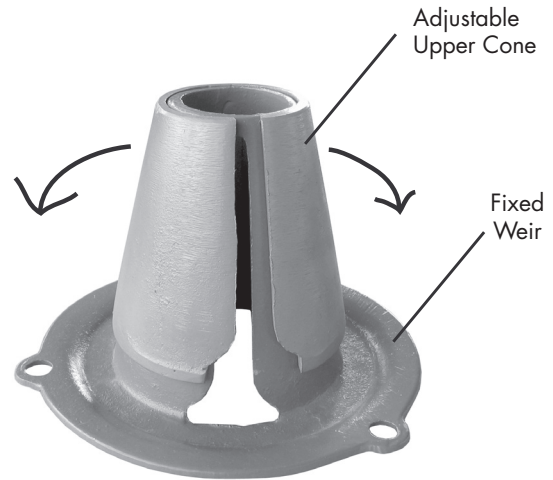
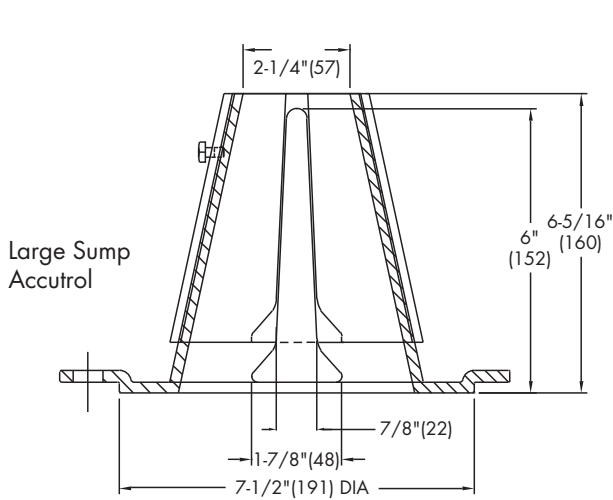

1/2 Weir Opening Exposed Shown Above

TABLE 1. Adjustable Accutrol Flow Rate Settings

Weir Opening Exposed	1"	2"	3"	4"	5"	6"
	Flow Rate (gallons per minute)					
Fully Exposed	5	10	15	20	25	30
3/4	5	10	13.75	17.5	21.25	25
1/2	5	10	12.5	15	17.5	20
1/4	5	10	11.25	12.5	13.75	15
Closed	5	5	5	5	5	5

Job Name _____
 Job Location _____
 Engineer _____

Contractor _____
 Contractor's P.O. No. _____
 Representative _____

Watts product specifications in U.S. customary units and metric are approximate and are provided for reference only. For precise measurements, please contact Watts Technical Service. Watts reserves the right to change or modify product design, construction, specifications, or materials without prior notice and without incurring any obligation to make such changes and modifications on Watts products previously or subsequently sold.

USA: Tel: (800) 338-2581 • Fax: (828) 248-3929 • Watts.com
 Canada: Tel: (905) 332-4090 • Fax: (905) 332-7068 • Watts.ca
 Latin America: Tel: (52) 81-1001-8600 • Fax: (52) 81-8000-7091 • Watts.com



AREA B4 - CB2 ICD SIZING

Chart 1: LMF 14 Preset Flow Curves

Tempest LMF90

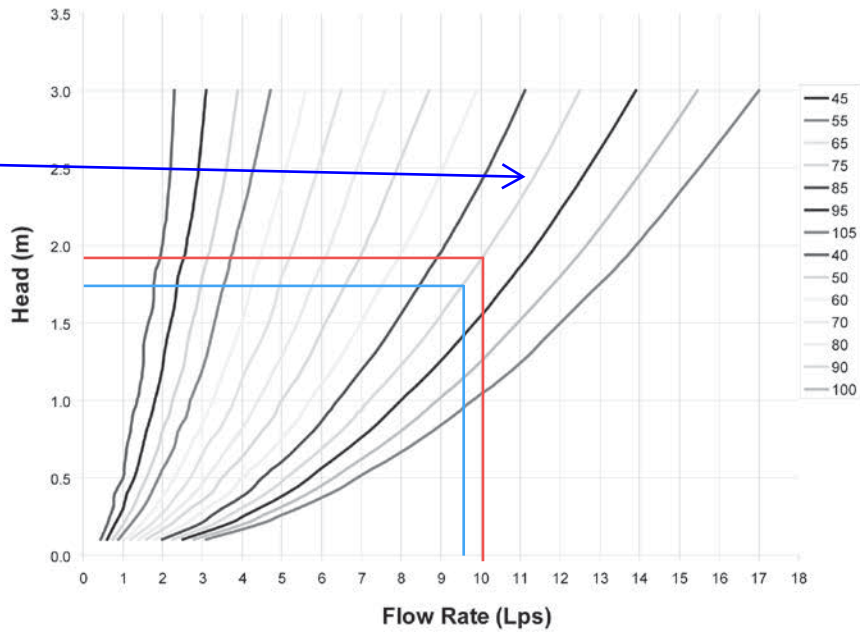

— 5-Year Storm
— 100-Year Storm

Chart 2: LMF Flow vs. ICD Alternatives

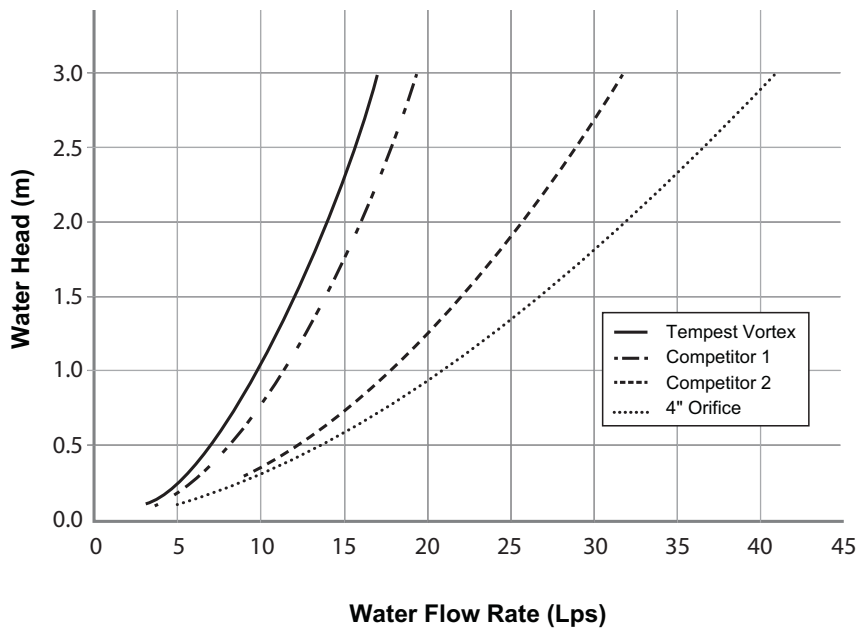

AREA B5 - CB3 ICD SIZING

Chart 1: LMF 14 Preset Flow Curves

Tempest LMF40

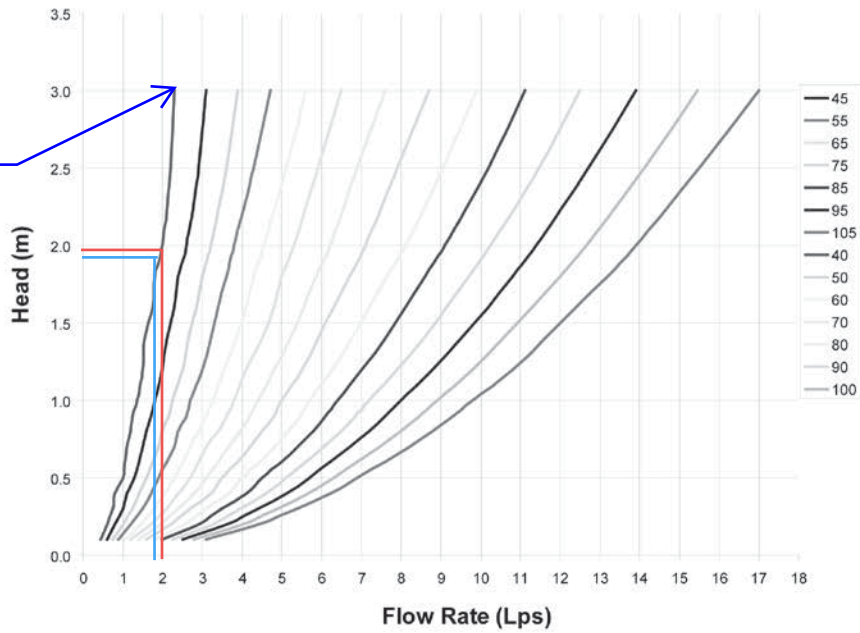

5-Year Storm
100-Year Storm

Chart 2: LMF Flow vs. ICD Alternatives

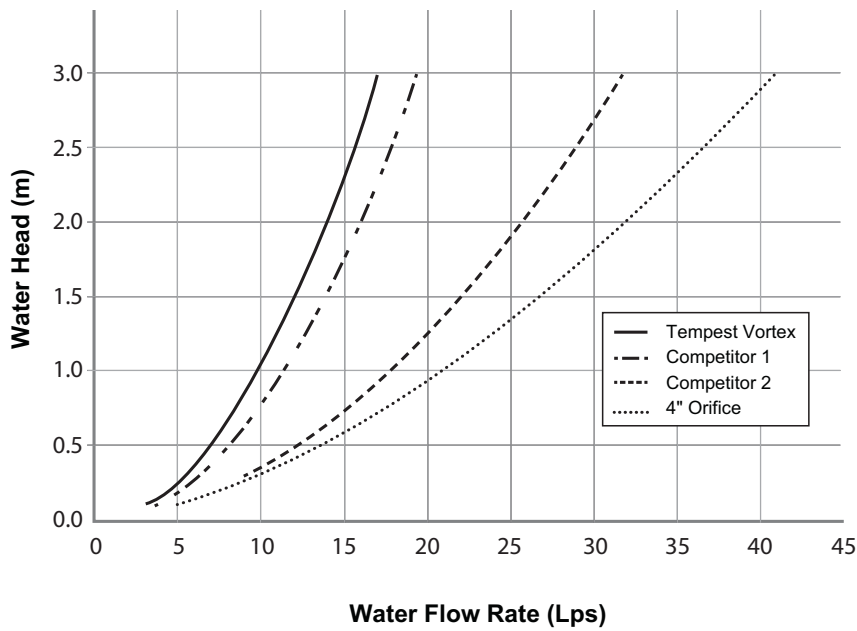

AREA B6 - CB4 ICD SIZING

Chart 1: LMF 14 Preset Flow Curves

Tempest LMF45

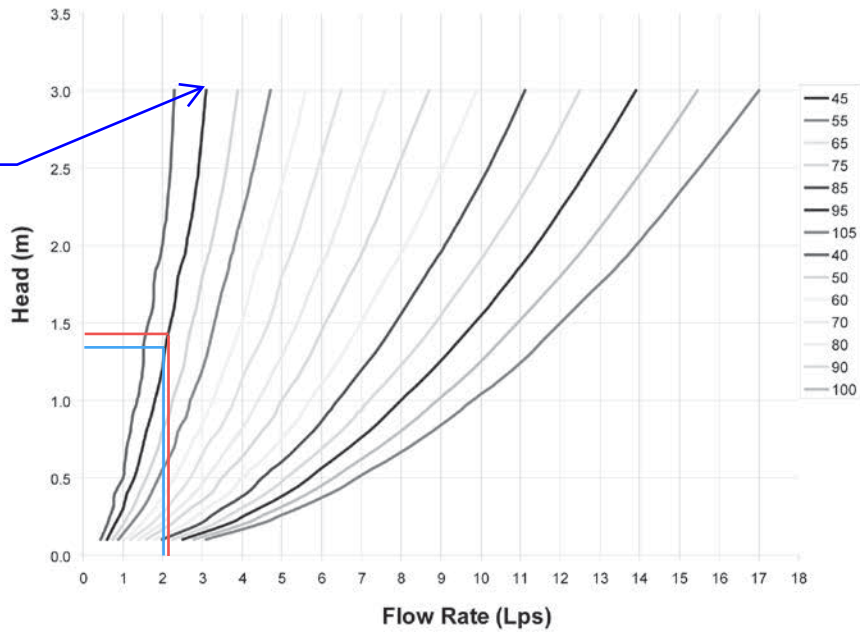

5-Year Storm
100-Year Storm

Chart 2: LMF Flow vs. ICD Alternatives

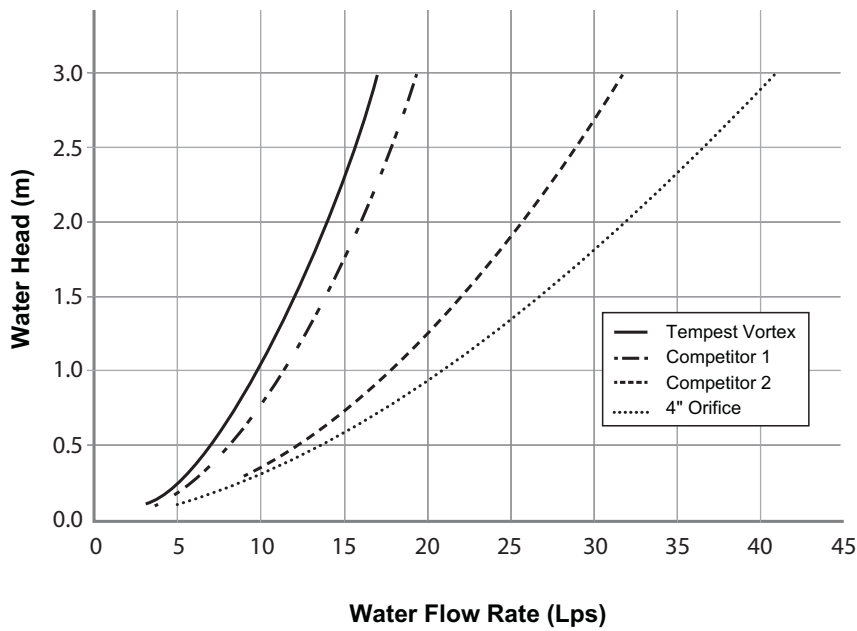

AREA B3 STORAGE TANK

Parameters

Units: Metric

Storage Volume: 10 Cu m

Chamber Selection: S-29

Header Row Position: Left

Fill Over Embedment Stone: 300 mm

Controlled By: width 5 m

Embedment Stone mm:

Over: 150 Under: 150 Porosity: 0.4

Min 150mm over and under

Double Stacked

Double Stacked?: No

Stone Between:

Note: After making an input change you must hit calculate to update the Field Diagram and Project Results.

* The image generation will not save if using MicroSoft Edge

Project Results

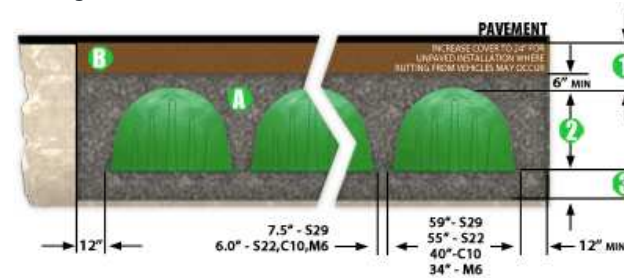

- 1 Total Cover Over Chambers: 301 mm
- 2 Height Of Chamber: 915 mm
- 3 Embedment Stone Under Chambers: 151 mm
- A Volume of Embedment Stone Required: 15 Cu. m
- B Volume of Fill Material Required: 6 Cu. m

Total Storage Provided: 12 Cu. m

Type Of Chambers: S-29

Of Chambers Required: 7

Of End Caps Required: 6

Required Bed Size: 17 Sq. m

Volume of Excavation: 21 Cu. m

* Area of Filter Fabric: 37 Sq. m

of Chambers Long: 2

of rows: 2

Actual Trench Length: 4.39 m

Actual Trench Width: 3.80 m

* Filter Fabric quantity for Fabric on Top and Sides of System Only, does not include overlap

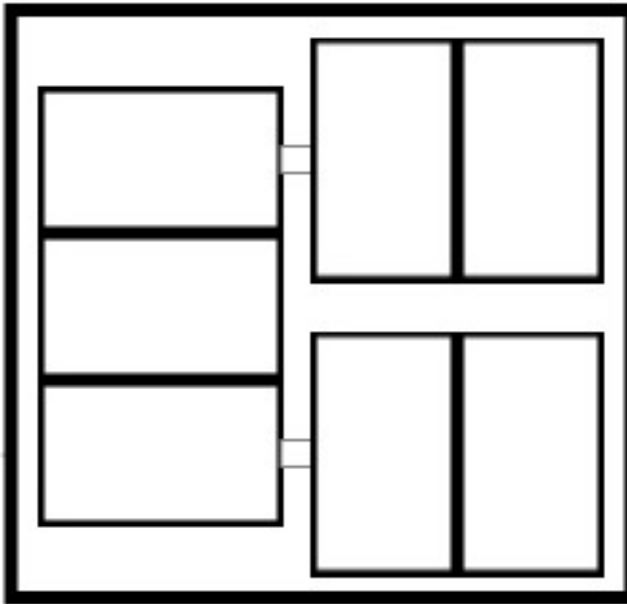

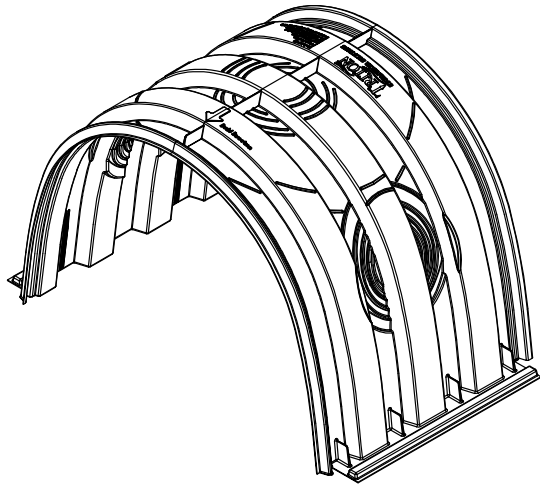

S-29 CHAMBER SPECS	
NOMINAL DIMENSIONS (LAYUP LENGTH X WIDTH X HEIGHT)	33.35" X 59.00" X 36.00" (847mm X 1499mm X 914mm)
BARE CHAMBER STORAGE	27.35 CUBIC FEET (0.774 CUBIC METERS)
*MIN INSTALLED STORAGE	41.05 CUBIC FEET (1.162 CUBIC METERS)
CHAMBER WEIGHT	32 lbs (14.515 kg)
STORAGE PER LINEAR FOOT WITHOUT STONE	9.84 CUBIC FEET (0.279 CUBIC METERS)
STORAGE PER LINEAR FOOT WITH STONE	14.77 CUBIC FEET (0.418 CUBIC METERS)

*ASSUMING A MIN OF 6" (152mm) STONE ABOVE AND BELOW AND 7.5" (191mm) BETWEEN ROWS WITH 40% STONE POROSITY (DOES NOT INCLUDE 12" (305mm) PERIMETER STONE VOLUME)

NOTE: S-29 CHAMBER DETAILS TESTED AND RATED FOR H-30 LOAD CONDITIONS WITH 18" (457mm) OF COVER AND NO PAVEMENT.

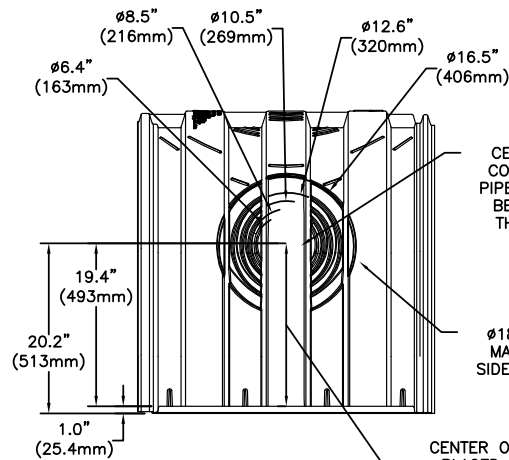
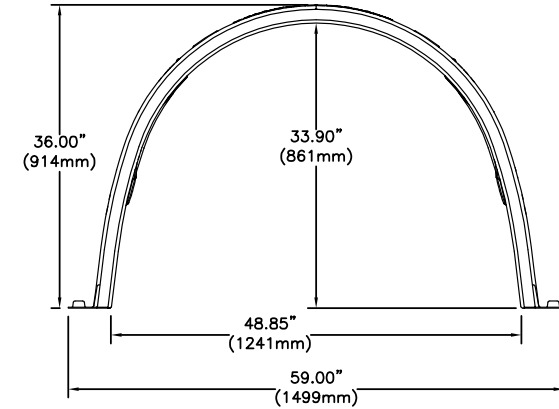

CENTER OF CONNECTING PIPES NOT TO BE HIGHER THAN THIS POINT

Ø18" (450mm)
MAX O.D. FOR SIDE CONNECTION

MUST MAINTAIN 1" (25.4mm) CLEARANCE IF CENTER OF PIPE CONNECTION IS LOWER THAN 19.4" (493mm)

CENTER OF CONNECTING PIPE CAN BE PLACED ALONG THE CENTERLINE AS LONG AS THE INVERT OF PIPE IS WITHIN THIS DIMENSION AND THE CENTER OF THE PIPE IS NO HIGHER THAN THE 19.4" (493mm) DIMENSION

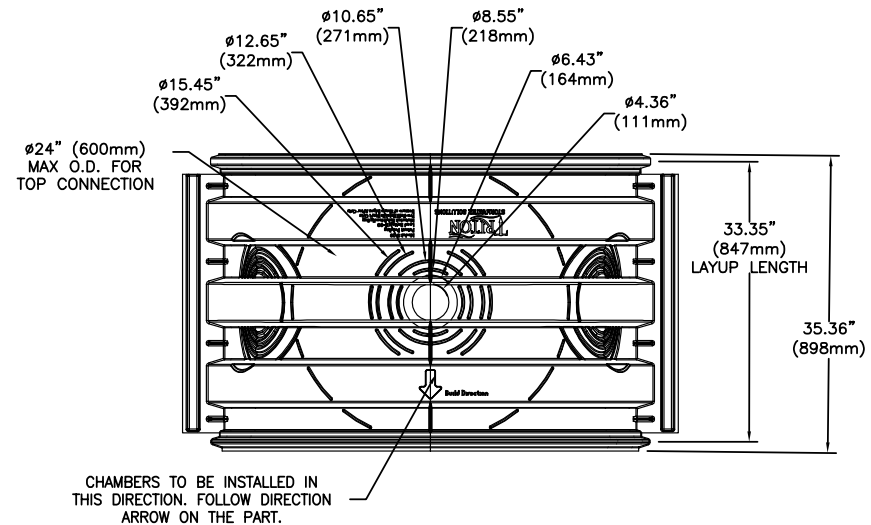

CHAMBERS TO BE INSTALLED IN THIS DIRECTION. FOLLOW DIRECTION ARROW ON THE PART.

CONCEPTUAL PLAN DISCLAIMER

THIS GENERIC DETAIL DOES NOT ENCOMPASS THE SIZING, FIT, AND APPLICABILITY OF THE TRITON CHAMBER SYSTEM FOR THIS SPECIFIC PROJECT. IT IS THE ULTIMATE RESPONSIBILITY OF THE DESIGN ENGINEER TO ASSURE THAT THE STORMWATER SYSTEM DESIGN IS IN FULL COMPLIANCE WITH ALL APPLICABLE LAWS AND REGULATIONS. TRITON PRODUCTS MUST BE DESIGNED AND INSTALLED IN ACCORDANCE WITH TRITON'S MINIMUM REQUIREMENTS. TRITON STORMWATER SOLUTIONS DOES NOT APPROVE PLANS, SIZING, OR SYSTEM DESIGNS. THE DESIGN ENGINEER IS RESPONSIBLE FOR ALL DESIGN DECISIONS.



7600 EAST GRAND RIVER, STE.195
BRIGHTON, MI 48114
PHONE: (810) 222-7652 • FAX: (810) 222-1769
WWW.TRITONSW.COM

S-29 CHAMBER DETAIL

TRITON - STANDARD DETAILS

REVISED:
02-26-16 JWM

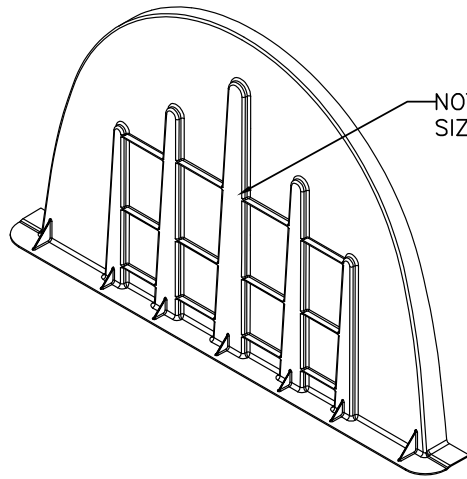

S-29 END CAP SPECS	
NOMINAL DIMENSIONS (LAYUP LENGTH X WIDTH X HEIGHT)	5.90" X 59.00" X 36.00" (150mm X 1499mm X 914mm)
BARE END CAP STORAGE	1.031 CUBIC FEET (0.029 CUBIC METERS)
*MIN INSTALLED STORAGE	4.98 CUBIC FEET (0.141 CUBIC METERS)

*ASSUMING A MIN OF 6" (152mm) STONE ABOVE AND BELOW AND 7.5" (191mm) BETWEEN ROWS WITH 40% STONE POROSITY (DOES NOT INCLUDE 12" (305mm) PERIMETER STONE VOLUME)

Ø32" (810mm) MAX O.D.
FOR END CONNECTION
(see page 2 for guide diameters)

ALL PIPE CONNECTIONS
MUST BE INSTALLED ALONG
CHAMBER CAP CENTERLINE.

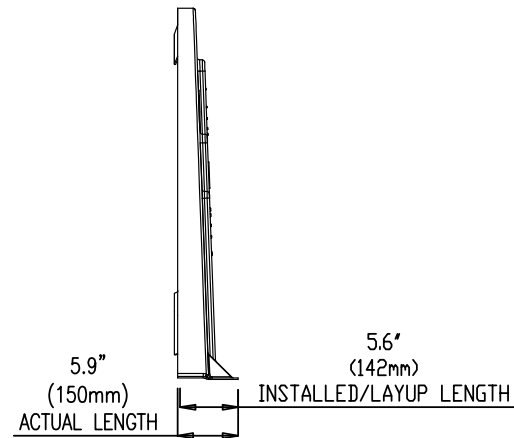
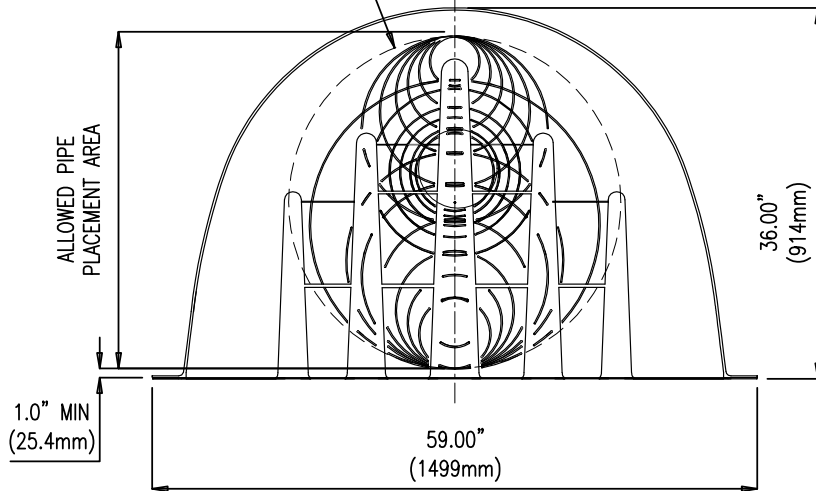

THE END CAP FITS UP ON THE OUTSIDE
OF THE S-29 CHAMBER. REFER TO
INSTALLATION MANUAL FOR FURTHER DETAIL.

CONCEPTUAL PLAN DISCLAIMER
THIS GENERIC DETAIL DOES NOT ENCOMPASS THE SIZING, FIT, AND APPLICABILITY OF THE TRITON CHAMBER SYSTEM FOR THIS SPECIFIC PROJECT. IT IS THE ULTIMATE RESPONSIBILITY OF THE DESIGN ENGINEER TO ASSURE THAT THE STORMWATER SYSTEM DESIGN IS IN FULL COMPLIANCE WITH ALL APPLICABLE LAWS AND REGULATIONS. TRITON PRODUCTS MUST BE DESIGNED AND INSTALLED IN ACCORDANCE WITH TRITON'S MINIMUM REQUIREMENTS. TRITON STORMWATER SOLUTIONS DOES NOT APPROVE PLANS, SIZING, OR SYSTEM DESIGNS. THE DESIGN ENGINEER IS RESPONSIBLE FOR ALL DESIGN DECISIONS.



7600 EAST GRAND RIVER, STE.195
BRIGHTON, MI 48114
PHONE: (810) 222-7652 • FAX: (810) 222-1769
WWW.TRITONSW.COM

S-29 CHAMBER END CAP DETAIL

TRITON - STANDARD DETAILS

PAGE 1 OF 2

REVISED:
02-26-16 JWM

S-29 END CAP:
TOP HOLE DIMENSIONS

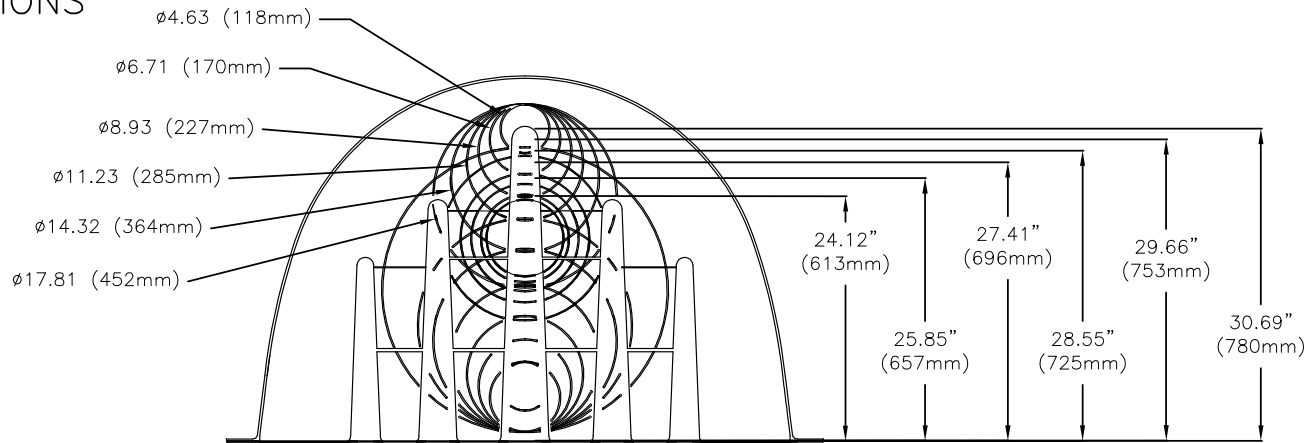

S-29 END CAP:
CENTER AND BOTTOM HOLE DIMENSIONS

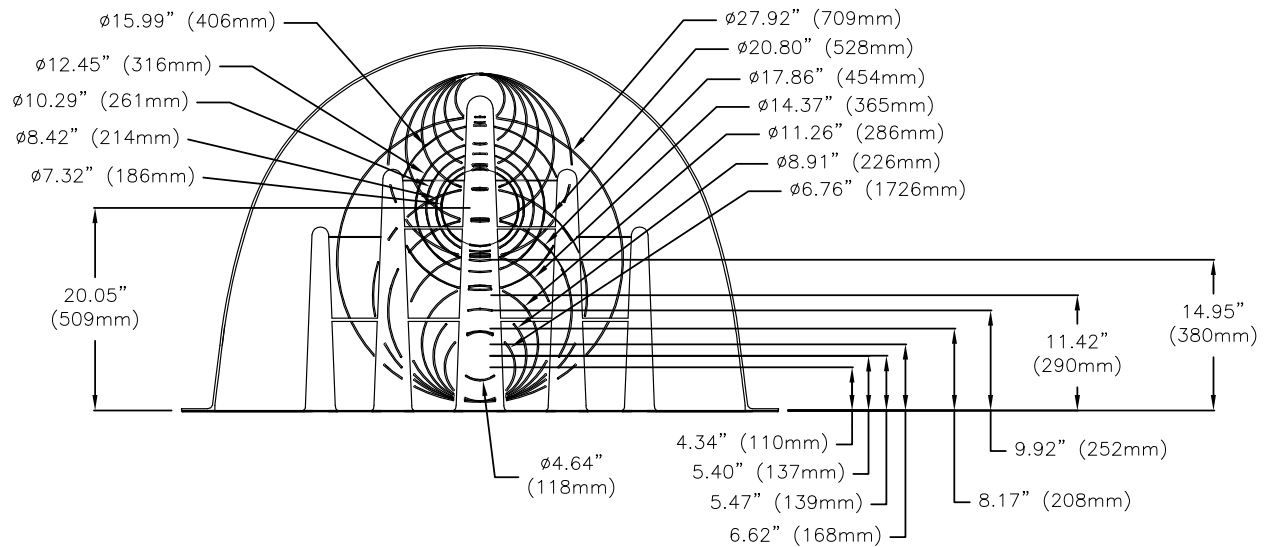

CONCEPTUAL PLAN DISCLAIMER
THIS GENERIC DETAIL DOES NOT ENCOMPASS THE SIZING, FIT, AND APPLICABILITY OF THE TRITON CHAMBER SYSTEM FOR THIS SPECIFIC PROJECT. IT IS THE ULTIMATE RESPONSIBILITY OF THE DESIGN ENGINEER TO ASSURE THAT THE STORMWATER SYSTEM DESIGN IS IN FULL COMPLIANCE WITH ALL APPLICABLE LAWS AND REGULATIONS. TRITON PRODUCTS MUST BE DESIGNED AND INSTALLED IN ACCORDANCE WITH TRITON'S MINIMUM REQUIREMENTS. TRITON STORMWATER SOLUTIONS DOES NOT APPROVE PLANS, SIZING, OR SYSTEM DESIGNS. THE DESIGN ENGINEER IS RESPONSIBLE FOR ALL DESIGN DECISIONS.



7600 EAST GRAND RIVER, STE.195
BRIGHTON, MI 48114
PHONE: (810) 222-7652 • FAX: (810) 222-1769
WWW.TRITONSW.COM

S-29 CHAMBER END CAP DETAIL

TRITON - STANDARD DETAILS

PAGE 2 OF 2

REVISED:
02-26-16 JWM

TRITON S-29 PRODUCT SPECIFICATIONS

1.0 General

1.1 Triton chambers are designed to control stormwater runoff. As a subsurface retention or detention system, Triton chambers retain and allow effective infiltration of water into the soil. As a subsurface detention system, Triton chambers detain and allow for the metered flow of water to an outfall.

2.0 Chamber Parameters

2.1 The chamber shall be injection compression molded of a structural grade 1010 green soy resin composite to be inherently resistant to environmental stress cracking (ESCR), creep, and to maintain proper stiffness through temperature ranges of -40 degrees F to 180 degrees F.

2.2 The material property for the chamber and end cap must meet or exceed the following:

- Tensile Strength- Ultimate: 21,755 PSI
- Tensile Strength-Yield: 17,404 PSI
- Tensile Modulus: 1,750-2,240 PSI
- Flex Modulus: 1,600 KSI
- Flex Yield Strength: 33,100 PSI
- Compressive Strength: 30,457,000 PSI
- Shear Strength: 11,500 PSI

2.3 The nominal chamber dimensions of the Triton S-29 shall be 36.0 inches tall, 59.0 inches wide and 35.0 inches long. Lay-up length is 33.35"

2.4 The chamber shall have an elliptical curved section profile.

2.5 The chamber shall be open-bottomed.

2.6 The chamber shall incorporate an overlapping corrugation joint system to allow chamber rows to be constructed.

2.7 The nominal storage volume of a Triton S-29 chamber shall be 41.06 cubic feet per chamber when installed per Triton's typical details. This equates to 2.67 cubic feet of storage/square foot of bed. This does not include perimeter stone.

2.8 The chamber shall have both of its ends open to allow for unimpeded hydraulic flows and visual inspections down a row's entire length.

2.9 The chamber shall have five corrugations to achieve strengths defined above.

2.10 The chamber shall have five circular and elliptical, indented and raised, surfaces on the top of the chamber for a maximum of 33 inch diameter optional top feed inlets, inspection ports and or clean-out access ports.

2.11 The chamber shall have 5 elliptical, indented, surfaces on either side of the chamber for optional feed inlets, outlets. Capable of accepting pipe O.D. up to 18 inches.

2.12 The chamber shall be analyzed, designed and field tested using AASHTO LRFD bridge design specifications 1. Design live load shall meet or exceed the AASHTO HS30 or a rear axle load of 48,000 pounds. Design shall consider earth and live loads without pavement as appropriate for the minimum of 18" of total cover to a maximum total cover of 50'.

2.13 The chamber shall be manufactured in an ISO 9001:2008 certified facility

2.14 The service life of the product is over 60 years under a constant sustained load of 10,000 PSI which is equal to the H-20 loading condition. Under typical loading conditions the Chamber and End Cap has a useful lifespan of 120 years from date of when manufactured.

2.15 Designed to exceed ASTM F2418, F2787, F2922 standard and AASHTO LRFD Bridge specifications. Validated through independent third party performance testing.

3.0 End Cap Parameters

3.1 The end cap shall be Injection Compression molded of 1010 green soy resin to be inherently resistant to environmental stress cracking (ESCR), creep and to maintain proper stiffness through temperature ranges of -40 degrees F to 180 degrees F.

3.2 The end cap shall be designed to fit over the last corrugation of a chamber, which allows: the capping of each end of the chamber row.

3.3 The end cap shall have six upper saw guides capable of accepting pipe O.D. up to 18.2" Six middle saw guides and eight lower saw guides capable of accepting pipe O.D. up to 28.2" to allow easy cutting for various diameters of pipe that may be used to inlet or outlet the system.

3.4 The end cap shall have excess structural adequacies to allow cutting an orifice of any size at any invert elevation.

3.5 The primary face of an end cap shall have 5 corrugations and be angled outward to resist horizontal loads generated near the edges of beds.

3.6 The end cap shall be manufactured in an ISO 9001:2008 certified facility.

3.7 The service life of the product to be over 60 years under a sustained load of 10,000 PSI which is equal to the H-20 loading condition.

4.0 Installation

4.1 Installation shall be in accordance with the latest Triton Installation manual that can be downloaded from the Triton website:
www.tritonsws.com/support/downloads

CONCEPTUAL PLAN DISCLAIMER

THIS GENERIC DETAIL DOES NOT ENCOMPASS THE SIZING, FIT, AND APPLICABILITY OF THE TRITON CHAMBER SYSTEM FOR THIS SPECIFIC PROJECT. IT IS THE ULTIMATE RESPONSIBILITY OF THE DESIGN ENGINEER TO ASSURE THAT THE STORMWATER SYSTEM DESIGN IS IN FULL COMPLIANCE WITH ALL APPLICABLE LAWS AND REGULATIONS. TRITON PRODUCTS MUST BE DESIGNED AND INSTALLED IN ACCORDANCE WITH TRITON'S MINIMUM REQUIREMENTS. TRITON STORMWATER SOLUTIONS DOES NOT APPROVE PLANS, SIZING, OR SYSTEM DESIGNS. THE DESIGN ENGINEER IS RESPONSIBLE FOR ALL DESIGN DECISIONS.



7600 EAST GRAND RIVER, STE.195
 BRIGHTON, MI 48114
 PHONE: (810) 222-7652 • FAX: (810) 222-1769
WWW.TRITONSW.COM

S-29 PRODUCT SPECIFICATIONS

TRITON - STANDARD DETAILS

REVISED:

05-25-17 JWM

Ryan Robineau

From: Eric Lalande <eric.lalande@rvca.ca>
Sent: October 18, 2022 10:52 AM
To: Ryan Robineau
Cc: Robert Freel; Alison Gosling
Subject: RE: 1881-1883 Merivale Road RVCA Requirements

Hi Ryan,

Based on the plan circulated, the RVCA has no water quality control requirements on-site. It would appear that the both options provide some additional treatment via SWM facilities. Please confirm/include details if any as part of your Storm water design brief/ report.

Thank you,

Eric Lalande, MCIP, RPP
Planner, RVCA
613-692-3571 x1137

From: Ryan Robineau <r.robineau@mcintoshperry.com>
Sent: Tuesday, October 18, 2022 9:02 AM
To: Eric Lalande <eric.lalande@rvca.ca>
Cc: Robert Freel <r.freel@mcintoshperry.com>; Alison Gosling <a.gosling@mcintoshperry.com>
Subject: 1881-1883 Merivale Road RVCA Requirements

Good morning Eric,

We wanted to touch base with you regarding a proposed development at 1881-1883 Merivale Road.

The development involves the construction of a two 1-storey warehouses with surface parking. Drainage will be collected and conveyed to either the 450mm dia storm sewer within Jamie Avenue or the 450mm dia storm sewer within Merivale Road. Water travels more than 2.0 km in both sewers to the Rideau River (Outlet ID #12048). It is anticipated that drainage will be collected by catch basins and roof drains.

We would like to know what SWM requirements the RVCA would have for the site.

Please let me know if you have any questions.

Thank you,

Ryan Robineau, EIT
Civil Engineering Technologist
T. 613.714.6611
r.robineau@mcintoshperry.com | www.mcintoshperry.com

McINTOSH PERRY
Turning Possibilities Into Reality

APPENDIX H
CITY OF OTTAWA DESIGN CHECKLIST

City of Ottawa

4. Development Servicing Study Checklist

The following section describes the checklist of the required content of servicing studies. It is expected that the proponent will address each one of the following items for the study to be deemed complete and ready for review by City of Ottawa Infrastructure Approvals staff.

The level of required detail in the Servicing Study will increase depending on the type of application. For example, for Official Plan amendments and re-zoning applications, the main issues will be to determine the capacity requirements for the proposed change in land use and confirm this against the existing capacity constraint, and to define the solutions, phasing of works and the financing of works to address the capacity constraint. For subdivisions and site plans, the above will be required with additional detailed information supporting the servicing within the development boundary.

4.1 General Content

Criteria	Location (if applicable)
<input type="checkbox"/> Executive Summary (for larger reports only).	N/A
<input type="checkbox"/> Date and revision number of the report.	On Cover
<input type="checkbox"/> Location map and plan showing municipal address, boundary, and layout of proposed development.	Appendix A
<input type="checkbox"/> Plan showing the site and location of all existing services.	Site Servicing Plan (C102)
<input type="checkbox"/> Development statistics, land use, density, adherence to zoning and official plan, and reference to applicable subwatershed and watershed plans that provide context to which individual developments must adhere.	1.1 Purpose 1.2 Site Description 6.0 Stormwater Management
<input type="checkbox"/> Summary of pre-consultation meetings with City and other approval agencies.	Appendix B
<input type="checkbox"/> Reference and confirm conformance to higher level studies and reports (Master Servicing Studies, Environmental Assessments, Community Design Plans), or in the case where it is not in conformance, the proponent must provide justification and develop a defensible design criteria.	1.1 Purpose 1.2 Site Description 6.0 Stormwater Management
<input type="checkbox"/> Statement of objectives and servicing criteria.	3.0 Pre-Consultation Summary

<input type="checkbox"/> Identification of existing and proposed infrastructure available in the immediate area.	N/A
<input type="checkbox"/> Identification of Environmentally Significant Areas, watercourses and Municipal Drains potentially impacted by the proposed development (Reference can be made to the Natural Heritage Studies, if available).	Ste Grading Plan (C101)
<input type="checkbox"/> Concept level master grading plan to confirm existing and proposed grades in the development. This is required to confirm the feasibility of proposed stormwater management and drainage, soil removal and fill constraints, and potential impacts to neighbouring properties. This is also required to confirm that the proposed grading will not impede existing major system flow paths.	Ste Grading Plan (C101)
<input type="checkbox"/> Identification of potential impacts of proposed piped services on private services (such as wells and septic fields on adjacent lands) and mitigation required to address potential impacts.	N/A
<input type="checkbox"/> Proposed phasing of the development, if applicable.	N/A
<input type="checkbox"/> Reference to geotechnical studies and recommendations concerning servicing.	Section 2.0 Background Studies, Standards and References
<input type="checkbox"/> All preliminary and formal site plan submissions should have the following information: <ul style="list-style-type: none"> ○ Metric scale ○ North arrow (including construction North) ○ Key plan ○ Name and contact information of applicant and property owner ○ Property limits including bearings and dimensions ○ Existing and proposed structures and parking areas ○ Easements, road widening and rights-of-way ○ Adjacent street names 	Ste Grading Plan (C101)

4.2 Development Servicing Report: Water

Criteria	Location (if applicable)
<input type="checkbox"/> Confirm consistency with Master Servicing Study, if available	N/A
<input type="checkbox"/> Availability of public infrastructure to service proposed development	N/A
<input type="checkbox"/> Identification of system constraints	N/A
<input type="checkbox"/> Identify boundary conditions	Appendix C
<input type="checkbox"/> Confirmation of adequate domestic supply and pressure	N/A
<input type="checkbox"/> Confirmation of adequate fire flow protection and confirmation that fire flow is calculated as per the Fire Underwriter's Survey. Output should show available fire flow at locations throughout the development.	Appendix C
<input type="checkbox"/> Provide a check of high pressures. If pressure is found to be high, an assessment is required to confirm the application of pressure reducing valves.	N/A
<input type="checkbox"/> Definition of phasing constraints. Hydraulic modeling is required to confirm servicing for all defined phases of the project including the ultimate design	N/A
<input type="checkbox"/> Address reliability requirements such as appropriate location of shut-off valves	N/A
<input type="checkbox"/> Check on the necessity of a pressure zone boundary modification.	N/A
<input type="checkbox"/> Reference to water supply analysis to show that major infrastructure is capable of delivering sufficient water for the proposed land use. This includes data that shows that the expected demands under average day, peak hour and fire flow conditions provide water within the required pressure range	Appendix C, Section 4.2

<input type="checkbox"/> Description of the proposed water distribution network, including locations of proposed connections to the existing system, provisions for necessary looping, and appurtenances (valves, pressure reducing valves, valve chambers, and fire hydrants) including special metering provisions.	Site Servicing Plan (C101)
<input type="checkbox"/> Description of off-site required feeder mains, booster pumping stations, and other water infrastructure that will be ultimately required to service proposed development, including financing, interim facilities, and timing of implementation.	N/A
<input type="checkbox"/> Confirmation that water demands are calculated based on the City of Ottawa Design Guidelines.	Appendix C
<input type="checkbox"/> Provision of a model schematic showing the boundary conditions locations, streets, parcels, and building locations for reference.	N/A

4.3 Development Servicing Report: Wastewater

Criteria	Location (if applicable)
<input type="checkbox"/> Summary of proposed design criteria (Note: Wet-weather flow criteria should not deviate from the City of Ottawa Sewer Design Guidelines. Monitored flow data from relatively new infrastructure cannot be used to justify capacity requirements for proposed infrastructure).	N/A
<input type="checkbox"/> Confirm consistency with Master Servicing Study and/or justifications for deviations.	N/A
<input type="checkbox"/> Consideration of local conditions that may contribute to extraneous flows that are higher than the recommended flows in the guidelines. This includes groundwater and soil conditions, and age and condition of sewers.	N/A
<input type="checkbox"/> Description of existing sanitary sewer available for discharge of wastewater from proposed development.	Section 5.2 Proposed Sanitary Sewer

<input type="checkbox"/> Verify available capacity in downstream sanitary sewer and/or identification of upgrades necessary to service the proposed development. (Reference can be made to previously completed Master Servicing Study if applicable)	Section 5.3 Proposed Sanitary Design
<input type="checkbox"/> Calculations related to dry-weather and wet-weather flow rates from the development in standard MOE sanitary sewer design table (Appendix 'C') format.	N/A
<input type="checkbox"/> Description of proposed sewer network including sewers, pumping stations, and forcemains.	Section 5.2 Proposed Sanitary Sewer
<input type="checkbox"/> Discussion of previously identified environmental constraints and impact on servicing (environmental constraints are related to limitations imposed on the development in order to preserve the physical condition of watercourses, vegetation, soil cover, as well as protecting against water quantity and quality).	N/A
<input type="checkbox"/> Pumping stations: impacts of proposed development on existing pumping stations or requirements for new pumping station to service development.	N/A
<input type="checkbox"/> Forcemain capacity in terms of operational redundancy, surge pressure and maximum flow velocity.	N/A
<input type="checkbox"/> Identification and implementation of the emergency overflow from sanitary pumping stations in relation to the hydraulic grade line to protect against basement flooding.	N/A
<input type="checkbox"/> Special considerations such as contamination, corrosive environment etc.	N/A

4.4 Development Servicing Report: Stormwater Checklist

Criteria	Location (if applicable)
<input type="checkbox"/> Description of drainage outlets and downstream constraints including legality of outlets (i.e. municipal drain, right-of-way, watercourse, or private property)	Section 6.0 Stormwater Sewer Design & Section 7.0 Proposed Stormwater Management
<input type="checkbox"/> Analysis of available capacity in existing public infrastructure.	N/A
<input type="checkbox"/> A drawing showing the subject lands, its surroundings, the receiving watercourse, existing drainage patterns, and proposed drainage pattern.	Pre & Post-Development Plans
<input type="checkbox"/> Water quantity control objective (e.g. controlling post-development peak flows to pre-development level for storm events ranging from the 2 or 5-year event (dependent on the receiving sewer design) to 100-year return period); if other objectives are being applied, a rationale must be included with reference to hydrologic analyses of the potentially affected subwatersheds, taking into account long-term cumulative effects.	Section 6.0 Stormwater Sewer Design & Section 7.0 Proposed Stormwater Management
<input type="checkbox"/> Water Quality control objective (basic, normal or enhanced level of protection based on the sensitivities of the receiving watercourse) and storage requirements.	Section 6.0 Stormwater Sewer Design & Section 7.0 Proposed Stormwater Management
<input type="checkbox"/> Description of the stormwater management concept with facility locations and descriptions with references and supporting information.	Section 6.0 Stormwater Sewer Design & Section 7.0 Proposed Stormwater Management
<input type="checkbox"/> Set-back from private sewage disposal systems.	N/A
<input type="checkbox"/> Watercourse and hazard lands setbacks.	N/A
<input type="checkbox"/> Record of pre-consultation with the Ontario Ministry of Environment and the Conservation Authority that has jurisdiction on the affected watershed.	N/A
<input type="checkbox"/> Confirm consistency with sub-watershed and Master Servicing Study, if applicable study exists.	N/A
<input type="checkbox"/> Storage requirements (complete with calculations) and conveyance capacity for minor events (1:5-year return period) and major events (1:100-year return period).	Appendix G

<input type="checkbox"/> Identification of watercourses within the proposed development and how watercourses will be protected, or, if necessary, altered by the proposed development with applicable approvals.	Site Grading Plan
<input type="checkbox"/> Calculate pre-and post development peak flow rates including a description of existing site conditions and proposed impervious areas and drainage catchments in comparison to existing conditions.	Section 7.0 Proposed Stormwater Management Appendix G
<input type="checkbox"/> Any proposed diversion of drainage catchment areas from one outlet to another.	Section 6.0 Stormwater Sewer Design & Section 7.0 Proposed Stormwater Management
<input type="checkbox"/> Proposed minor and major systems including locations and sizes of stormwater trunk sewers, and stormwater management facilities.	Section 6.0 Stormwater Sewer Design & Section 7.0 Proposed Stormwater Management
<input type="checkbox"/> If quantity control is not proposed, demonstration that downstream system has adequate capacity for the post-development flows up to and including the 100-year return period storm event.	N/A
<input type="checkbox"/> Identification of potential impacts to receiving watercourses	N/A
<input type="checkbox"/> Identification of municipal drains and related approval requirements.	N/A
<input type="checkbox"/> Descriptions of how the conveyance and storage capacity will be achieved for the development.	Section 6.0 Stormwater Sewer Design & Section 7.0 Proposed Stormwater Management
<input type="checkbox"/> 100-year flood levels and major flow routing to protect proposed development from flooding for establishing minimum building elevations (MBE) and overall grading.	Site Grading Plan (C101)
<input type="checkbox"/> Inclusion of hydraulic analysis including hydraulic grade line elevations.	N/A

<input type="checkbox"/> Description of approach to erosion and sediment control during construction for the protection of receiving watercourse or drainage corridors.	Section 8.0 Sediment & Erosion Control
<input type="checkbox"/> Identification of floodplains – proponent to obtain relevant floodplain information from the appropriate Conservation Authority. The proponent may be required to delineate floodplain elevations to the satisfaction of the Conservation Authority if such information is not available or if information does not match current conditions.	N/A
<input type="checkbox"/> Identification of fill constraints related to floodplain and geotechnical investigation.	N/A

4.5 Approval and Permit Requirements: Checklist

The Servicing Study shall provide a list of applicable permits and regulatory approvals necessary for the proposed development as well as the relevant issues affecting each approval. The approval and permitting shall include but not be limited to the following:

Criteria	Location (if applicable)
<input type="checkbox"/> Conservation Authority as the designated approval agency for modification of floodplain, potential impact on fish habitat, proposed works in or adjacent to a watercourse, cut/fill permits and Approval under Lakes and Rivers Improvement Act. The Conservation Authority is not the approval authority for the Lakes and Rivers Improvement Act. Where there are Conservation Authority regulations in place, approval under the Lakes and Rivers Improvement Act is not required, except in cases of dams as defined in the Act.	N/A
<input type="checkbox"/> Application for Certificate of Approval (CofA) under the Ontario Water Resources Act.	N/A
<input type="checkbox"/> Changes to Municipal Drains.	N/A
<input type="checkbox"/> Other permits (National Capital Commission, Parks Canada, Public Works and Government Services Canada, Ministry of Transportation etc.)	N/A

4.6 Conclusion Checklist

Criteria	Location (if applicable)
<input type="checkbox"/> Clearly stated conclusions and recommendations	Section 9.0 Summary Section 10.0 Recommendations
<input type="checkbox"/> Comments received from review agencies including the City of Ottawa and information on how the comments were addressed. Final sign-off from the responsible reviewing agency.	All are stamped
<input type="checkbox"/> All draft and final reports shall be signed and stamped by a professional Engineer registered in Ontario	All are stamped