

Proj. 221021  
 Ottawa Community Housing  
 OCH Friel Street / Chapel  
 200-201 Friel Street (200 Beausoleil Drive)  
 Ottawa, ON  
 K1N 8Z2

Issued for Rezoning and Site Plan Control - Resubmission #1  
 05/18/2023

**SURVEY**

492.22 Registered Plan 43586

**ARCHITECTURAL**

A010 Site Plan  
 A011 Site Plan - Zoom In  
 A040 Building Statistics  
 A100.A Basement Floor Plan  
 A100.B Basement + Loading Area Plan  
 A301 North Exterior Building Elevation  
 A302 East and West Exterior Building Elevations  
 A303 South Exterior Building Elevation

**LANDSCAPE**

D1-1 Demolition Plan  
 L1-1 Landscape Plan  
 L1-2 POPA Area Landscape Plan  
 L1-3 Planting Plan  
 L2-1 Details  
 L2-2 Site Plan - Extra Property  
 TP-1 Tree Protection Plan

**CIVIL**

C000 Cover  
 C001 Site Servicing Plan  
 C002 Grading Plan  
 C003 Erosion and Sediment Control  
 C101 Details (1 of 4)  
 C102 Details (2 of 4)  
 C103 Details (3 of 4)  
 C104 Details (4 of 4)  
 C700 Removals Plan  
 C701 Roof Drain Layout & Ponding  
 C800 Existing Drainage Area Plan  
 C801 Proposed Drainage Area Plan



Architect  
**Diamond Schmitt Architects**  
 384 Adelaide Street West, Suite 100  
 Toronto, ON M5V 1R7  
 T: (416)-862-8800

Architect  
**KWC Architects Inc.**  
 383 Parkdale Avenue, Suite 201  
 Ottawa, ON K1Y 4R4  
 T: (613)-239-2117

Planner  
**WSP**  
 2611 Queensview Drive #300  
 Ottawa, ON K2B 8K2  
 T: (613)-829-2800

Civil  
**Morrison Hershfield**  
 2932 Baseline Road  
 Ottawa, ON K2H 1B1  
 T: (613)-739-2910

Electrical  
**Smith + Andersen**  
 1600 Carling Avenue #530  
 Ottawa, ON K1Z 1G3  
 T: (613)-230-1186

Landscape  
**Lashley + Associates**  
 950 Gladstone Avenue #202  
 Ottawa, ON K1Y 3E6  
 T: (613)-233-8579

Mechanical  
**Smith + Andersen**  
 1600 Carling Avenue #530  
 Ottawa, ON K1Z 1G3  
 T: (613)-230-1186

Building Envelope  
**RDH Building Science Inc.**  
 26 Soho Street #350  
 Toronto, ON M5T 1Z7  
 T: (416)-314-2329

Hardware  
**LT Consulting**

Energy Modelling  
**RDH Building Science Inc.**  
 26 Soho Street #350  
 Toronto, ON M5T 1Z7  
 T: (416)-314-2328

**diamond  
 schmitt**

<b>Architect</b> <b>Diamond Schmitt Architects</b> 384 Adelaide Street West, Suite 100 Toronto, ON M5V 1R7 T: (416)-862-8800  <b>Architect</b> <b>KWC Architects Inc.</b> 383 Parkdale Avenue, Suite 201 Ottawa, ON K1Y 4R4 T: (613)-238-2117	<b>Planner</b> <b>WSP</b> 2611 Queensview Drive #300 Ottawa, ON K2B 8K2 T: (613)-829-2800  <b>Civil</b> <b>Morrison Hershfield</b> 2932 Baseline Road Ottawa, ON K2H 1B1 T: (613)-739-2910	<b>Electrical</b> <b>Smith + Andersen</b> 1600 Carling Avenue #530 Ottawa, ON K1Z 1G3 T: (613)-230-1186  <b>Landscape</b> <b>Lashley + Associates</b> 950 Gladstone Avenue #202 Ottawa, ON K1Y 3E6 T: (613)-233-8579	<b>Mechanical</b> <b>Smith + Andersen</b> 1600 Carling Avenue #530 Ottawa, ON K1Z 1G3 T: (613)-230-1186  <b>Building Envelope</b> <b>RDH Building Science Inc.</b> 26 Soho Street #350 Toronto, ON M5T 1Z7 T: (416)-314-2328	<b>Hardware</b> <b>LT Consulting</b>   <b>Energy Modelling</b> <b>RDH Building Science Inc.</b> 26 Soho Street #350 Toronto, ON M5T 1Z7 T: (416)-314-2328
---	--	--	--	---

No.	Date	Description
1	22 MAR 2023	Issued For Recording and Site Plan Control
2	18 MAY 2023	Issued For Recording and Site Plan Control - Resubmission #1

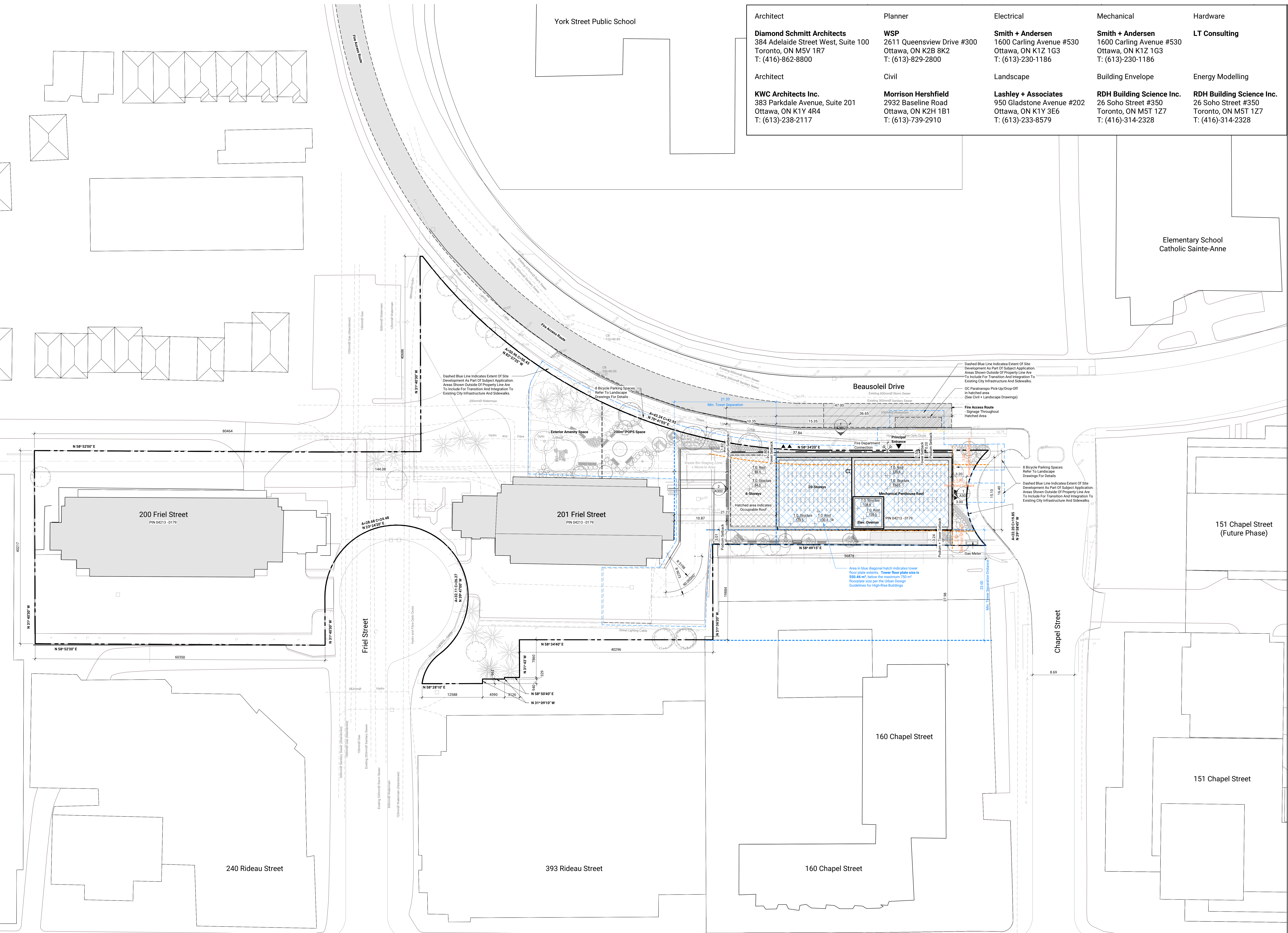

**Site Plan Symbols Legend**

- Main Building Entry
- Building Egress Path
- Zoning Dimension
- Zoning Definition
- Urban Design Highlight Guideline Dimension
- Urban Design Highlight Guideline Definition
- Setback Dimensions
- Detailed Dimensions
- Building Elevation
- North Arrow
- Fire Hydrant
- Slimease Connection

**NOT FOR CONSTRUCTION**

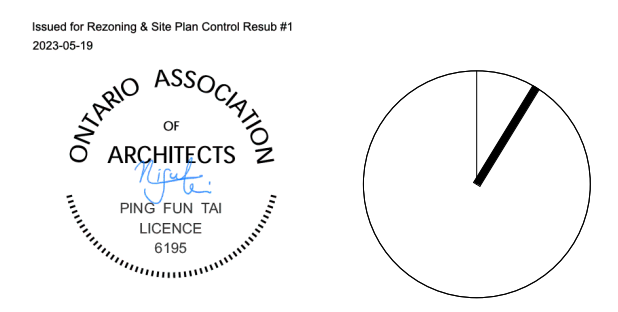

**Site Plan Developed Based On Site Survey By Farley, Smith & Densi Surveying LTD.:**

Site Area: 7235.9m<sup>2</sup>

LOTS 1 AND 2 (West Friel Street), PART OF LOT 19 (North Rideau Street), PART OF LOTS 1, 2, 3 AND 4 (East Friel Street), PART OF LOTS 1, 2 AND 3 (West Chapel Street), PART OF FRIEL STREET (As Closed by By-Law 203-72, Inst. CR616467) REGISTERED PLAN 43586 CITY OF OTTAWA

Gross Floor Area (SPA)			Amenity Areas (SPA)			Exemption A - Mech. Service + Electrical (SPA)			Exemption B - Common Circulation (SPA)			Exemption C - Parking + Loading (SPA)			Unit Schedule - By Typical Level (SPA)			CMHC Accessible / CBC Barrier-Free Unit Schedule - By Typical Level (SPA)			
Level	Gross Floor Area (m <sup>2</sup> )	Gross Floor Area (ft <sup>2</sup> )	Level	Name	Area (m <sup>2</sup> )	Level	Area (m <sup>2</sup> )	Area (ft <sup>2</sup> )	Level	Area (m <sup>2</sup> )	Area (ft <sup>2</sup> )	Level	Area (m <sup>2</sup> )	Area (ft <sup>2</sup> )	Level	1 Bedroom	2 Bedroom	Level	1 Bedroom	2 Bedroom	
Level P1	96.92 m <sup>2</sup>	1043.21 ft <sup>2</sup>	Level 1	Outdoor Seating Area	113.46 m <sup>2</sup>	Level P1	219.21 m <sup>2</sup>	2359.51 ft <sup>2</sup>	Level P1	97.27 m <sup>2</sup>	1045.51 ft <sup>2</sup>	Level P1	285.91 m <sup>2</sup>	3077.50 ft <sup>2</sup>	Level 2	0	0	Level 2	0	0	
Level 2	229.36 m <sup>2</sup>	2468.84 ft <sup>2</sup>	Level 1	East Garden	37.30 m <sup>2</sup>	Level 1	3.44 m <sup>2</sup>	37.07 ft <sup>2</sup>	Level 2	138.45 m <sup>2</sup>	1490.24 ft <sup>2</sup>	Level 2	285.91 m <sup>2</sup>	3077.50 ft <sup>2</sup>	Level 3	0	0	Level 3	0	0	
Level 3	675.11 m <sup>2</sup>	7276.62 ft <sup>2</sup>	Level 1	Private Garden	38.87 m <sup>2</sup>	Level 2	4.02 m <sup>2</sup>	43.00 ft <sup>2</sup>	Level 3	96.35 m <sup>2</sup>	1039.89 ft <sup>2</sup>	Level 3	285.91 m <sup>2</sup>	3077.50 ft <sup>2</sup>	Level 4	0	0	Level 4	0	0	
Level 4	672.21 m <sup>2</sup>	7235.62 ft <sup>2</sup>	Level 1	Children's Play	189.66 m <sup>2</sup>	Level 3	42.20 m <sup>2</sup>	454.22 ft <sup>2</sup>	Level 4	91.41 m <sup>2</sup>	983.96 ft <sup>2</sup>	Level 4	285.91 m <sup>2</sup>	3077.50 ft <sup>2</sup>	Level 5	0	0	Level 5	0	0	
Level 5	672.21 m <sup>2</sup>	7235.62 ft <sup>2</sup>	Level 1	Games Lounge	64.34 m <sup>2</sup>	Level 4	15.15 m <sup>2</sup>	163.48 ft <sup>2</sup>	Level 5	93.03 m <sup>2</sup>	1001.40 ft <sup>2</sup>	Level 5	285.91 m <sup>2</sup>	3077.50 ft <sup>2</sup>	Level 6	0	0	Level 6	0	0	
Level 6	672.21 m <sup>2</sup>	7235.62 ft <sup>2</sup>	Level 1	Library	27.72 m <sup>2</sup>	Level 5	3.96 m <sup>2</sup>	42.63 ft <sup>2</sup>	Level 6	93.03 m <sup>2</sup>	1001.40 ft <sup>2</sup>	Level 6	285.91 m <sup>2</sup>	3077.50 ft <sup>2</sup>	Level 7	0	0	Level 7	0	0	
Level 7	362.70 m <sup>2</sup>	3904.12 ft <sup>2</sup>	Level 1	Flexible Seating	58.63 m <sup>2</sup>	Level 6	3.96 m <sup>2</sup>	42.63 ft <sup>2</sup>	Level 7	89.72 m <sup>2</sup>	964.84 ft <sup>2</sup>	Level 7	285.91 m <sup>2</sup>	3077.50 ft <sup>2</sup>	Level 8	0	0	Level 8	0	0	
Level 8	459.23 m <sup>2</sup>	4952.87 ft <sup>2</sup>	Level 1	Area + Activities	115.55 m <sup>2</sup>	Level 7	3.96 m <sup>2</sup>	42.63 ft <sup>2</sup>	Level 8	89.72 m <sup>2</sup>	964.84 ft <sup>2</sup>	Level 8	285.91 m <sup>2</sup>	3077.50 ft <sup>2</sup>	Level 9	0	0	Level 9	0	0	
Level 9	457.84 m <sup>2</sup>	4928.13 ft <sup>2</sup>	Level 1	WiFi	40.01 m <sup>2</sup>	Level 8	3.96 m <sup>2</sup>	42.63 ft <sup>2</sup>	Level 9	88.33 m <sup>2</sup>	950.73 ft <sup>2</sup>	Level 9	285.91 m <sup>2</sup>	3077.50 ft <sup>2</sup>	Level 10	0	0	Level 10	0	0	
Level 10	457.84 m <sup>2</sup>	4928.13 ft <sup>2</sup>	Level 1	Wellness	58.02 m <sup>2</sup>	Level 9	3.96 m <sup>2</sup>	42.63 ft <sup>2</sup>	Level 10	88.33 m <sup>2</sup>	950.73 ft <sup>2</sup>	Level 10	285.91 m <sup>2</sup>	3077.50 ft <sup>2</sup>	Level 11	0	0	Level 11	0	0	
Level 11	457.84 m <sup>2</sup>	4928.13 ft <sup>2</sup>	Level 1	Bookable	25.13 m <sup>2</sup>	Level 10	3.96 m <sup>2</sup>	42.63 ft <sup>2</sup>	Level 11	88.33 m <sup>2</sup>	950.73 ft <sup>2</sup>	Level 11	285.91 m <sup>2</sup>	3077.50 ft <sup>2</sup>	Level 12	0	0	Level 12	0	0	
Level 12	457.84 m <sup>2</sup>	4928.13 ft <sup>2</sup>	Level 7	Resident Terrace	141.19 m <sup>2</sup>	Level 11	3.96 m <sup>2</sup>	42.63 ft <sup>2</sup>	Level 12	88.33 m <sup>2</sup>	950.73 ft <sup>2</sup>	Level 12	285.91 m <sup>2</sup>	3077.50 ft <sup>2</sup>	Level 13	0	0	Level 13	0	0	
Level 13	457.84 m <sup>2</sup>	4928.13 ft <sup>2</sup>	Level 7	Quiet Seating	73.12 m <sup>2</sup>	Level 12	3.96 m <sup>2</sup>	42.63 ft <sup>2</sup>	Level 13	88.33 m <sup>2</sup>	950.73 ft <sup>2</sup>	Level 13	285.91 m <sup>2</sup>	3077.50 ft <sup>2</sup>	Level 14	0	0	Level 14	0	0	
Level 14	457.84 m <sup>2</sup>	4928.13 ft <sup>2</sup>	Grand total 13		962.21 m <sup>2</sup>	Level 13	3.96 m <sup>2</sup>	42.63 ft <sup>2</sup>	Level 14	88.33 m <sup>2</sup>	950.73 ft <sup>2</sup>	Level 14	285.91 m <sup>2</sup>	3077.50 ft <sup>2</sup>	Level 15	0	0	Level 15	0	0	
Level 15	457.84 m <sup>2</sup>	4928.13 ft <sup>2</sup>				Level 14	3.96 m <sup>2</sup>	42.63 ft <sup>2</sup>	Level 15	88.33 m <sup>2</sup>	950.73 ft <sup>2</sup>	Level 15	285.91 m <sup>2</sup>	3077.50 ft <sup>2</sup>	Level 16	0	0	Level 16	0	0	
Level 16	457.84 m <sup>2</sup>	4928.13 ft <sup>2</sup>				Level 15	3.96 m <sup>2</sup>	42.63 ft <sup>2</sup>	Level 16	88.33 m <sup>2</sup>	950.73 ft <sup>2</sup>	Level 16	285.91 m <sup>2</sup>	3077.50 ft <sup>2</sup>	Level 17	0	0	Level 17	0	0	
Level 17	457.84 m <sup>2</sup>	4928.13 ft <sup>2</sup>				Level 16	3.96 m <sup>2</sup>	42.63 ft <sup>2</sup>	Level 17	88.33 m <sup>2</sup>	950.73 ft <sup>2</sup>	Level 17	285.91 m <sup>2</sup>	3077.50 ft <sup>2</sup>	Level 18	0	0	Level 18	0	0	
Level 18	457.84 m <sup>2</sup>	4928.13 ft <sup>2</sup>				Level 17	3.96 m <sup>2</sup>	42.63 ft <sup>2</sup>	Level 18	88.33 m <sup>2</sup>	950.73 ft <sup>2</sup>	Level 18	285.91 m <sup>2</sup>	3077.50 ft <sup>2</sup>	Level 19	0	0	Level 19	0	0	
Level 19	457.84 m <sup>2</sup>	4928.13 ft <sup>2</sup>				Level 18	3.96 m <sup>2</sup>	42.63 ft <sup>2</sup>	Level 19	88.33 m <sup>2</sup>	950.73 ft <sup>2</sup>	Level 19	285.91 m <sup>2</sup>	3077.50 ft <sup>2</sup>	Level 20	0	0	Level 20	0	0	
Level 20	457.84 m <sup>2</sup>	4928.13 ft <sup>2</sup>				Level 19	3.96 m <sup>2</sup>	42.63 ft <sup>2</sup>	Level 20	88.33 m <sup>2</sup>	950.73 ft <sup>2</sup>	Level 20	285.91 m <sup>2</sup>	3077.50 ft <sup>2</sup>							
Mech. Penthouse	29.36 m <sup>2</sup>	315.63 ft <sup>2</sup>				Mech. Penthouse	254.19 m <sup>2</sup>	2736.13 ft <sup>2</sup>	Mech. Penthouse	24.89 m <sup>2</sup>	267.87 ft <sup>2</sup>										
	1040.55 m <sup>2</sup>	11247.63 ft <sup>2</sup>					579.81 m <sup>2</sup>	6197.82 ft <sup>2</sup>		1965.39 m <sup>2</sup>	2135.29 ft <sup>2</sup>										

Rideau Street

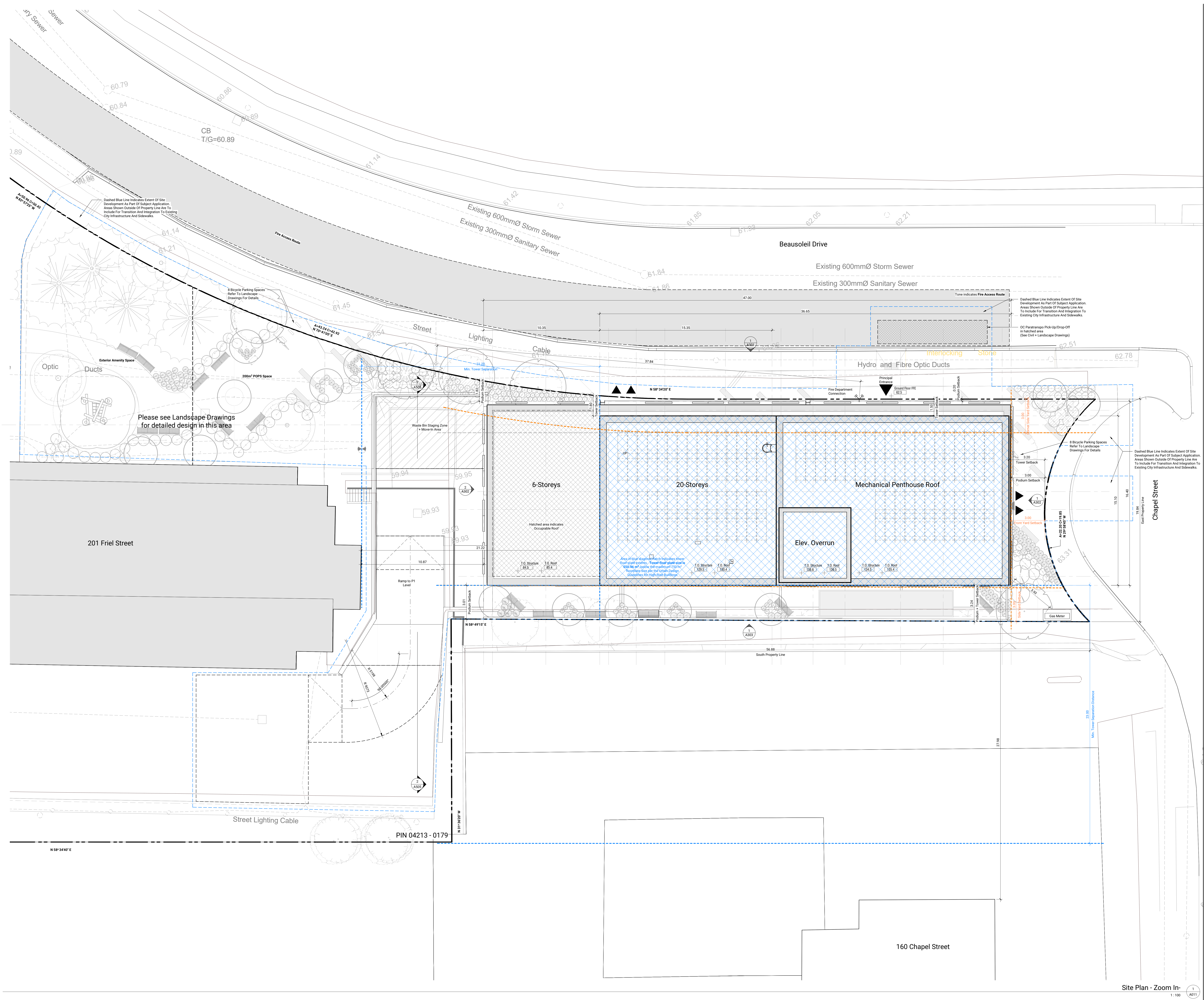

No.	Date	Description
1	22 MAR 2023	Issued for Rezoning and Site Plan Control
2	18 MAY 2023	Issued for Rezoning and Site Plan Control - Resubmission #1

Please see Landscape Drawings for detailed design in this area

Site Plan Symbols Legend	
	Main Building Entry
	Building Egress Path
	Zoning Dimension
	Zoning Definition
	Urban Design Height Guideline Dimension
	Urban Design Height Guideline Definition
	Setback Dimensions
	Detailed Dimensions
	Building Elevation
	North Arrow
	Fire Hydrant
	Slime Connection

**NOT FOR CONSTRUCTION**

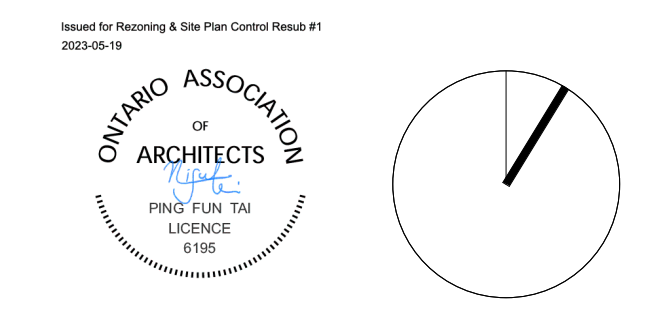

Contractor Must Check & Verify all Dimensions on the Job.  
Do Not Scale Drawings.  
All Drawings, Specifications and Related Documents are the Copyright Property of the Architect and shall be returned upon request. Reproduction or forwarding, modification or reuse of any part of this drawing without the written permission of the Architect.  
This Drawing is Not to be Used for Construction Until Signed by the Architect.

OCH Friel Street / Chapel  
200-201 Friel Street, Ottawa, ON K  
221021

Site Plan - Zoom In  
1:100  
**A011**

2023-05-15 10:17:19 AM C:\Users\jamesp\OneDrive\Documents\160 Chapel Street\160 Chapel Street\160 Chapel Street.dwg

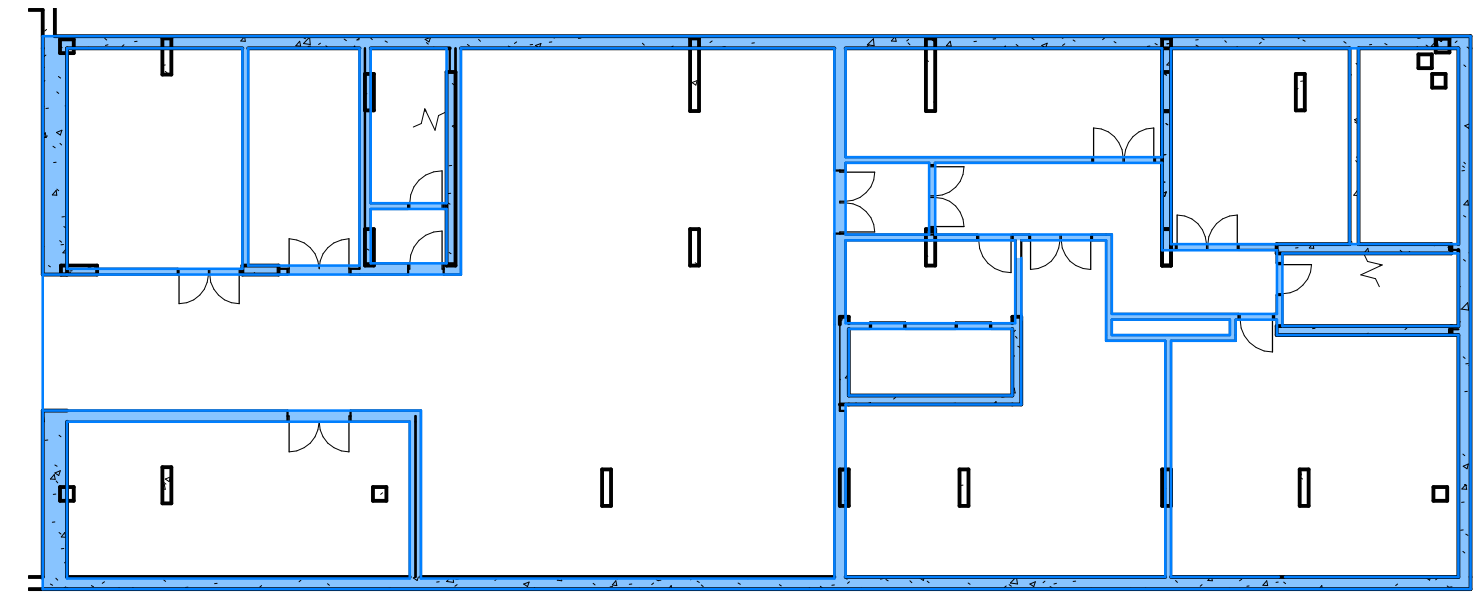

Level P1  
1:250 A040

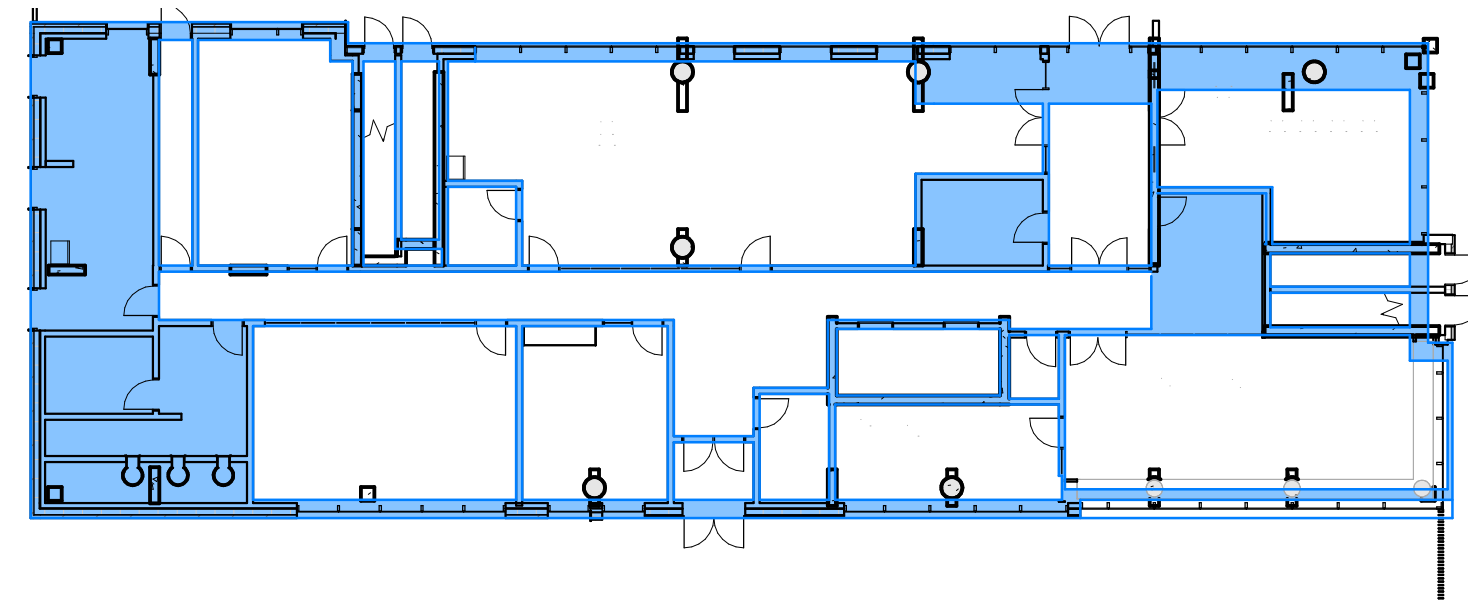

Level 1  
1:250 A040

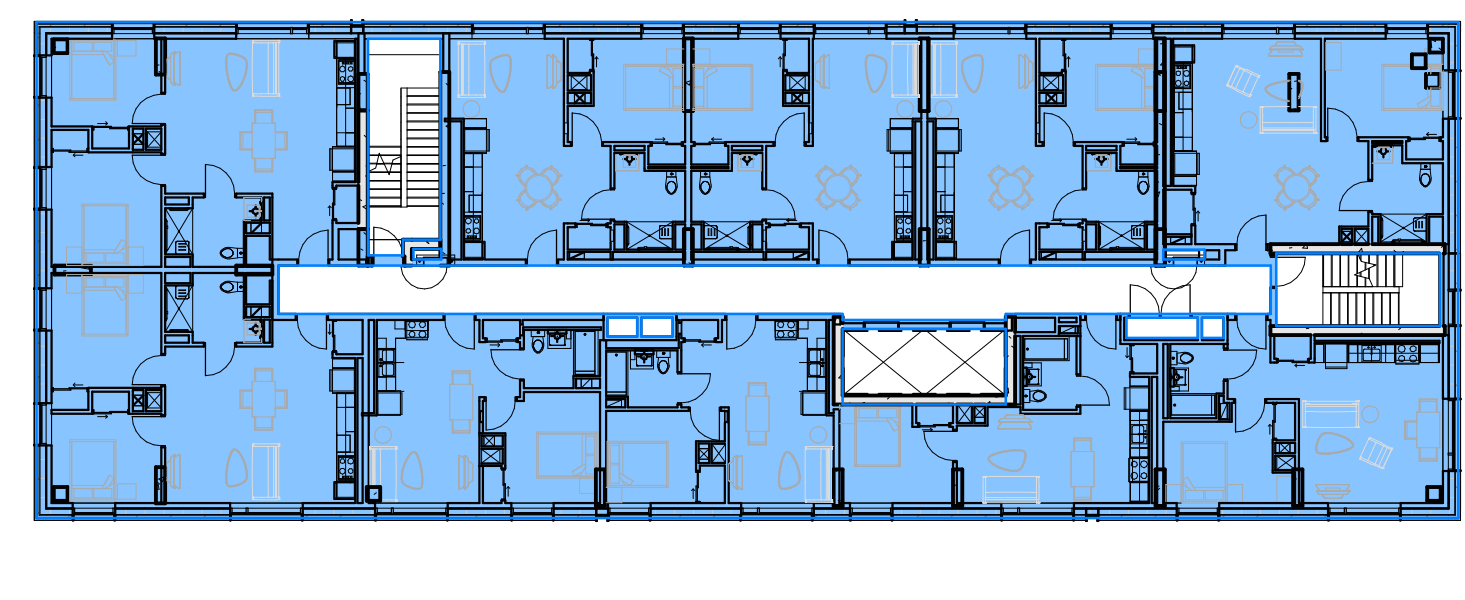

Typical Levels 2-6  
1:250 A040

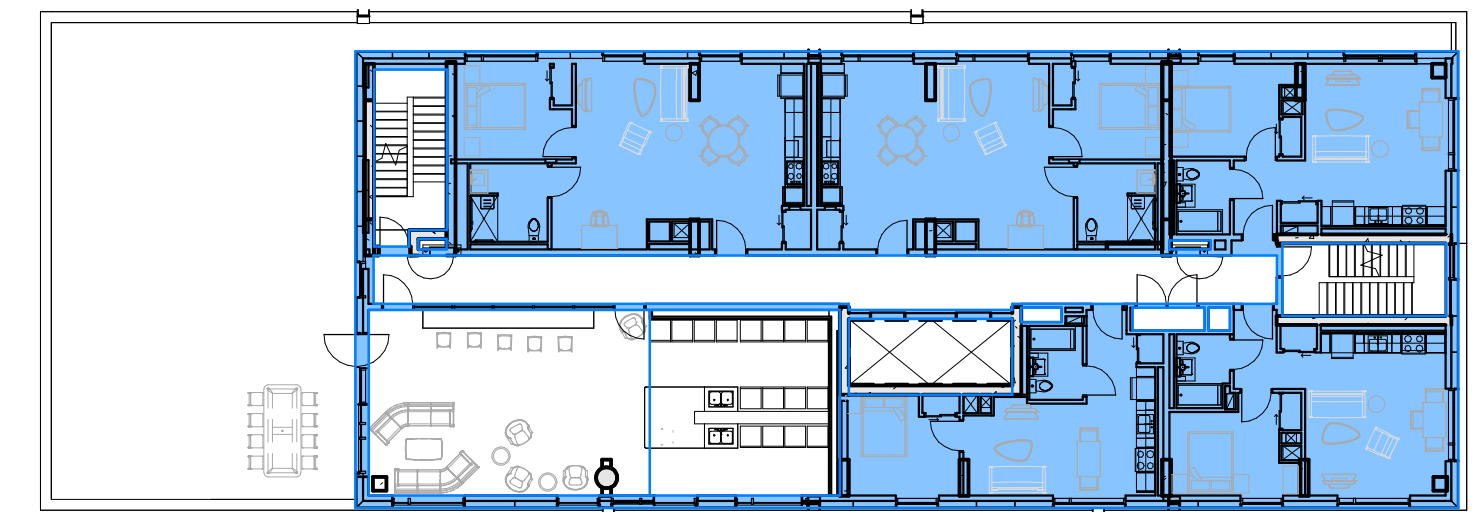

Level 7  
1:250 A040

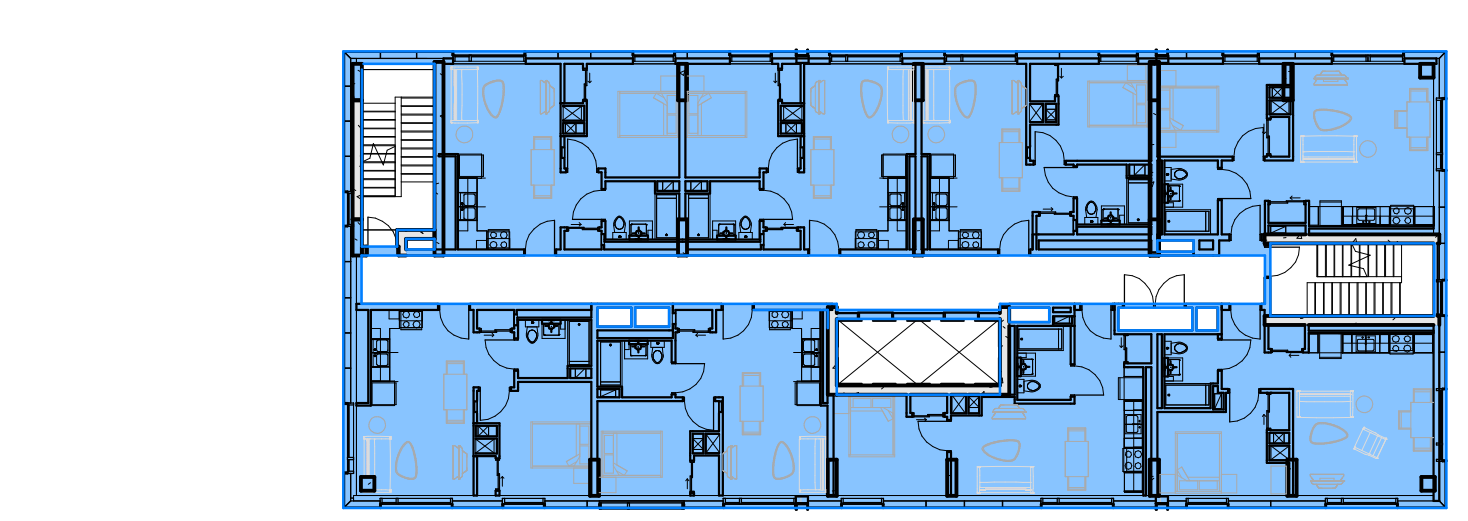

Typical Levels 8-20  
1:250 A040

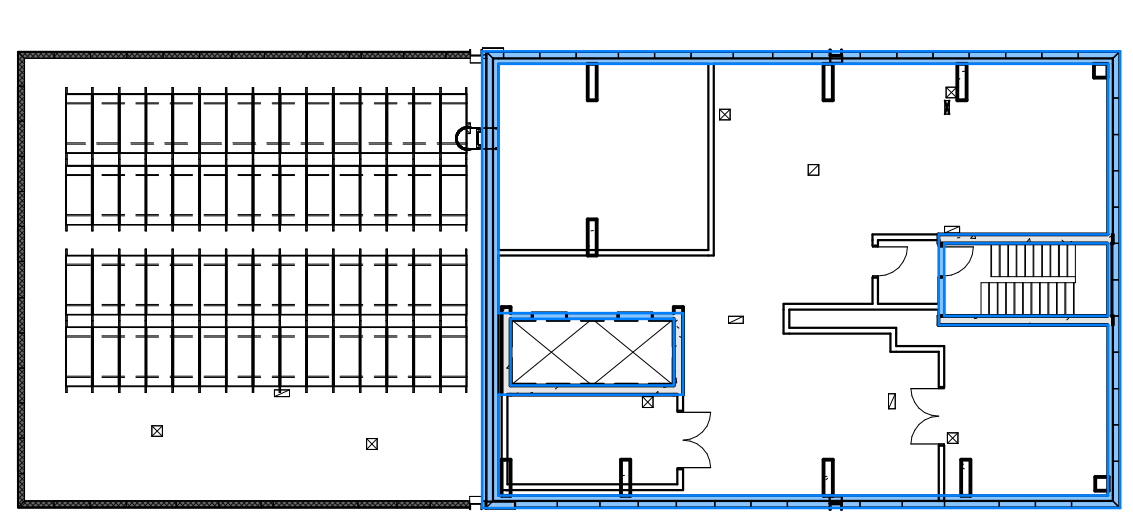

Mech. Penthouse  
1:250 A040

Unit Schedule - By Typical Level			CMHC Accessible / OBC Barrier-Free Unit Schedule - By Typical Level		
Level	1 Bedroom	2 Bedroom	Level	1 Bedroom Acc/BF	2 Bedroom Acc/BF
Level 2	8	2	Level 2	4	2
Level 3	8	2	Level 3	4	2
Level 4	8	2	Level 4	4	2
Level 5	8	2	Level 5	4	2
Level 6	8	2	Level 6	4	2
Level 7	8	2	Level 7	2	10
Level 8	8	2			
Level 9	8	2			
Level 10	8	2			
Level 11	8	2			
Level 12	8	2			
Level 13	8	2			
Level 14	8	2			
Level 15	8	2			
Level 16	8	2			
Level 17	8	2			
Level 18	8	2			
Level 19	8	2			
Level 20	8	2			
Suite Total	159	10			
% Overall	93.75%	6.25%	Target Units (DPA)	13.75%	6.25%

Gross Floor Area			Exemption A - Mech. Service + Electrical			Exemption B - Common Circulation			Exemption C - Parking + Loading		
Level	Gross Floor Area (m <sup>2</sup> )	Gross Floor Area (ft <sup>2</sup> )	Level	Area (m <sup>2</sup> )	Area (ft <sup>2</sup> )	Level	Area (m <sup>2</sup> )	Area (ft <sup>2</sup> )	Level	Area (m <sup>2</sup> )	Area (ft <sup>2</sup> )
Level P1	56.92 m <sup>2</sup>	1043.21 ft <sup>2</sup>	Level P1	219.21 m <sup>2</sup>	2359.51 ft <sup>2</sup>	Level P1	97.22 m <sup>2</sup>	1046.51 ft <sup>2</sup>	Level P1	285.91 m <sup>2</sup>	3077.50 ft <sup>2</sup>
Level 1	229.36 m <sup>2</sup>	2466.84 ft <sup>2</sup>	Level 1	3.44 m <sup>2</sup>	37.07 ft <sup>2</sup>	Level 1	1136.45 m <sup>2</sup>	1409.54 ft <sup>2</sup>	Level 1	13.90 m <sup>2</sup>	149.62 ft <sup>2</sup>
Level 2	670.18 m <sup>2</sup>	7213.73 ft <sup>2</sup>	Level 2	4.89 m <sup>2</sup>	44.80 ft <sup>2</sup>	Level 2	96.53 m <sup>2</sup>	1039.09 ft <sup>2</sup>	Level 2	13.90 m <sup>2</sup>	149.62 ft <sup>2</sup>
Level 3	675.11 m <sup>2</sup>	7266.82 ft <sup>2</sup>	Level 3	42.20 m <sup>2</sup>	454.22 ft <sup>2</sup>	Level 3	91.41 m <sup>2</sup>	983.96 ft <sup>2</sup>	Level 3	13.90 m <sup>2</sup>	149.62 ft <sup>2</sup>
Level 4	672.21 m <sup>2</sup>	7233.42 ft <sup>2</sup>	Level 4	5.15 m <sup>2</sup>	55.48 ft <sup>2</sup>	Level 4	93.03 m <sup>2</sup>	1001.40 ft <sup>2</sup>	Level 4	13.90 m <sup>2</sup>	149.62 ft <sup>2</sup>
Level 5	672.21 m <sup>2</sup>	7233.42 ft <sup>2</sup>	Level 5	3.96 m <sup>2</sup>	42.63 ft <sup>2</sup>	Level 5	93.03 m <sup>2</sup>	1001.40 ft <sup>2</sup>	Level 5	13.90 m <sup>2</sup>	149.62 ft <sup>2</sup>
Level 6	672.21 m <sup>2</sup>	7233.42 ft <sup>2</sup>	Level 6	3.96 m <sup>2</sup>	42.63 ft <sup>2</sup>	Level 6	93.03 m <sup>2</sup>	1001.40 ft <sup>2</sup>	Level 6	13.90 m <sup>2</sup>	149.62 ft <sup>2</sup>
Level 7	362.70 m <sup>2</sup>	3904.12 ft <sup>2</sup>	Level 7	3.96 m <sup>2</sup>	42.63 ft <sup>2</sup>	Level 7	88.72 m <sup>2</sup>	954.04 ft <sup>2</sup>	Level 7	13.90 m <sup>2</sup>	149.62 ft <sup>2</sup>
Level 8	456.23 m <sup>2</sup>	4910.87 ft <sup>2</sup>	Level 8	3.96 m <sup>2</sup>	42.63 ft <sup>2</sup>	Level 8	89.16 m <sup>2</sup>	959.68 ft <sup>2</sup>	Level 8	13.90 m <sup>2</sup>	149.62 ft <sup>2</sup>
Level 9	457.84 m <sup>2</sup>	4928.13 ft <sup>2</sup>	Level 9	3.96 m <sup>2</sup>	42.63 ft <sup>2</sup>	Level 9	88.33 m <sup>2</sup>	950.73 ft <sup>2</sup>	Level 9	13.90 m <sup>2</sup>	149.62 ft <sup>2</sup>
Level 10	457.84 m <sup>2</sup>	4928.13 ft <sup>2</sup>	Level 10	3.96 m <sup>2</sup>	42.63 ft <sup>2</sup>	Level 10	88.33 m <sup>2</sup>	950.73 ft <sup>2</sup>	Level 10	13.90 m <sup>2</sup>	149.62 ft <sup>2</sup>
Level 11	457.84 m <sup>2</sup>	4928.13 ft <sup>2</sup>	Level 11	3.96 m <sup>2</sup>	42.63 ft <sup>2</sup>	Level 11	88.33 m <sup>2</sup>	950.73 ft <sup>2</sup>	Level 11	13.90 m <sup>2</sup>	149.62 ft <sup>2</sup>
Level 12	457.84 m <sup>2</sup>	4928.13 ft <sup>2</sup>	Level 12	3.96 m <sup>2</sup>	42.63 ft <sup>2</sup>	Level 12	88.33 m <sup>2</sup>	950.73 ft <sup>2</sup>	Level 12	13.90 m <sup>2</sup>	149.62 ft <sup>2</sup>
Level 13	457.84 m <sup>2</sup>	4928.13 ft <sup>2</sup>	Level 13	3.96 m <sup>2</sup>	42.63 ft <sup>2</sup>	Level 13	88.33 m <sup>2</sup>	950.73 ft <sup>2</sup>	Level 13	13.90 m <sup>2</sup>	149.62 ft <sup>2</sup>
Level 14	457.84 m <sup>2</sup>	4928.13 ft <sup>2</sup>	Level 14	3.96 m <sup>2</sup>	42.63 ft <sup>2</sup>	Level 14	88.33 m <sup>2</sup>	950.73 ft <sup>2</sup>	Level 14	13.90 m <sup>2</sup>	149.62 ft <sup>2</sup>
Level 15	457.84 m <sup>2</sup>	4928.13 ft <sup>2</sup>	Level 15	3.96 m <sup>2</sup>	42.63 ft <sup>2</sup>	Level 15	88.33 m <sup>2</sup>	950.73 ft <sup>2</sup>	Level 15	13.90 m <sup>2</sup>	149.62 ft <sup>2</sup>
Level 16	457.84 m <sup>2</sup>	4928.13 ft <sup>2</sup>	Level 16	3.96 m <sup>2</sup>	42.63 ft <sup>2</sup>	Level 16	88.33 m <sup>2</sup>	950.73 ft <sup>2</sup>	Level 16	13.90 m <sup>2</sup>	149.62 ft <sup>2</sup>
Level 17	457.84 m <sup>2</sup>	4928.13 ft <sup>2</sup>	Level 17	3.96 m <sup>2</sup>	42.63 ft <sup>2</sup>	Level 17	88.33 m <sup>2</sup>	950.73 ft <sup>2</sup>	Level 17	13.90 m <sup>2</sup>	149.62 ft <sup>2</sup>
Level 18	457.84 m <sup>2</sup>	4928.13 ft <sup>2</sup>	Level 18	3.96 m <sup>2</sup>	42.63 ft <sup>2</sup>	Level 18	88.33 m <sup>2</sup>	950.73 ft <sup>2</sup>	Level 18	13.90 m <sup>2</sup>	149.62 ft <sup>2</sup>
Level 19	457.84 m <sup>2</sup>	4928.13 ft <sup>2</sup>	Level 19	3.96 m <sup>2</sup>	42.63 ft <sup>2</sup>	Level 19	88.33 m <sup>2</sup>	950.73 ft <sup>2</sup>	Level 19	13.90 m <sup>2</sup>	149.62 ft <sup>2</sup>
Level 20	457.84 m <sup>2</sup>	4928.13 ft <sup>2</sup>	Level 20	3.96 m <sup>2</sup>	42.63 ft <sup>2</sup>	Level 20	88.33 m <sup>2</sup>	950.73 ft <sup>2</sup>	Level 20	13.90 m <sup>2</sup>	149.62 ft <sup>2</sup>
Mech. Penthouse	1046.55 m <sup>2</sup>	11267.63 ft <sup>2</sup>	Mech. Penthouse	254.19 m <sup>2</sup>	2736.10 ft <sup>2</sup>	Mech. Penthouse	24.89 m <sup>2</sup>	267.87 ft <sup>2</sup>	Mech. Penthouse	491.12 m <sup>2</sup>	5284.19 ft <sup>2</sup>

Proposed Parking Supply	
Type	Count
OCH Parking	2
Residential Parking	2
Visitor Parking	4
	8

Proposed Bicycle Parking Supply		Bicycle Parking Standard Requirements	
Type	Count	Type	Count
Resident	64	0.5 Spaces per Unit (160 Units * 0.5)	80
Visitor	16		
	80		

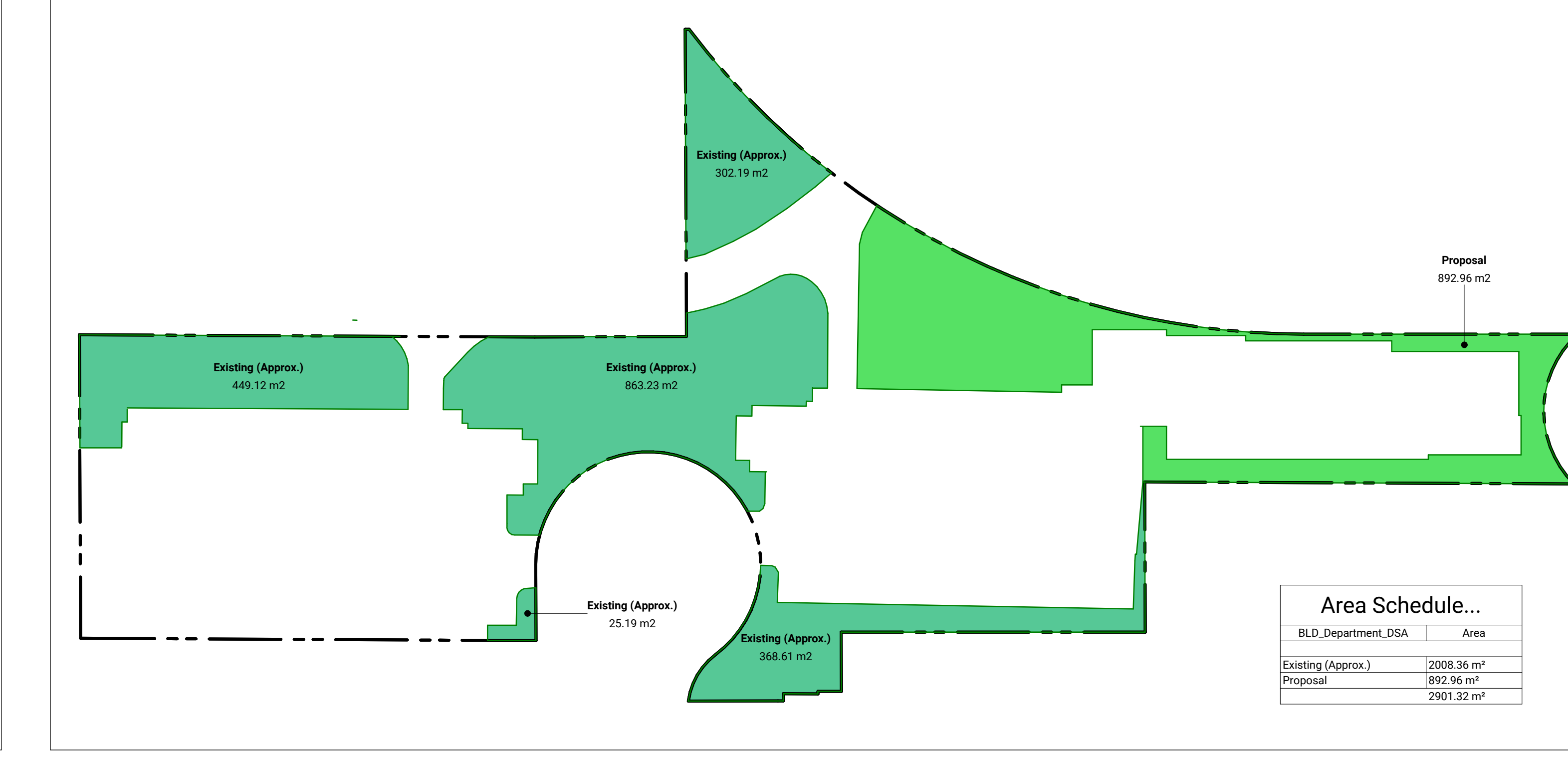

Vegetation & Landscaping Coverage  
1:500 A040

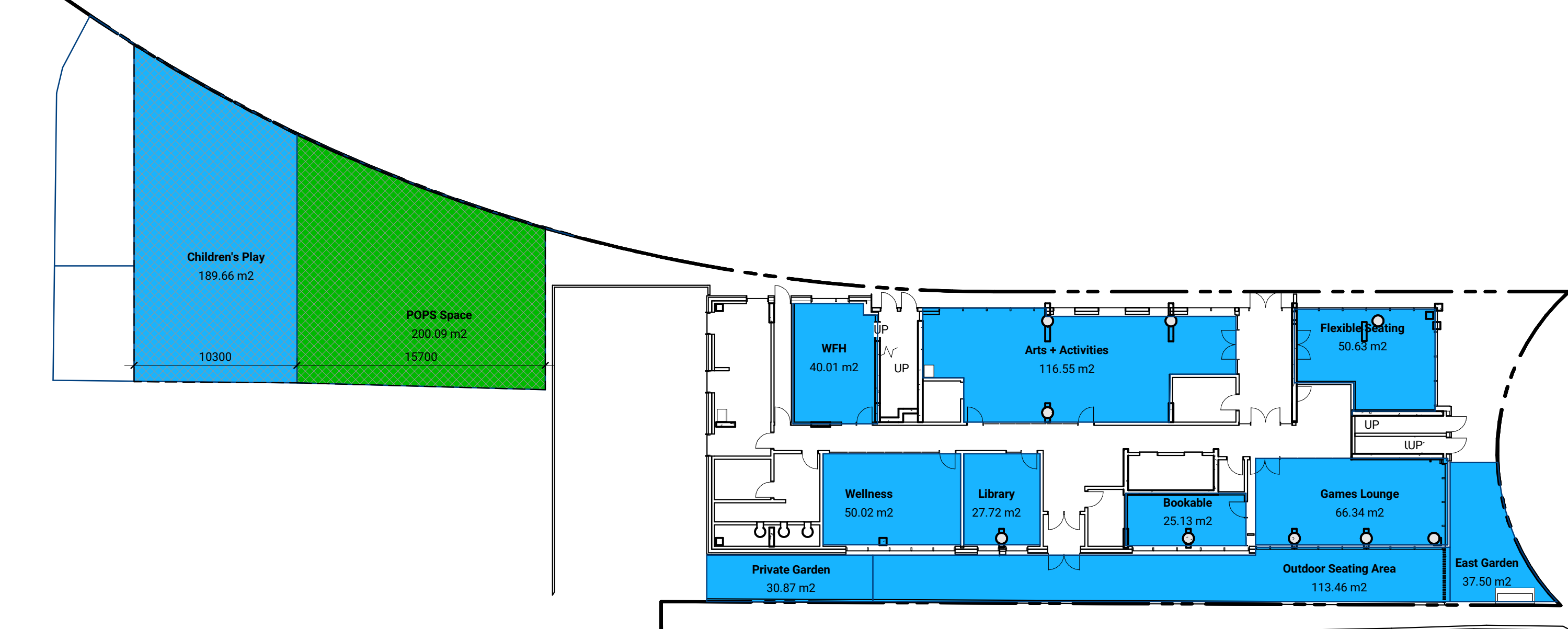

Level 1 Amenity + POPS Area Plan  
1:250 A040

Amenity Areas			
Level	Name	Area Type/JS	Area
Level 1	Outdoor Seating Area	Amenity Exterior	113.46 m <sup>2</sup>
Level 1	East Garden	Amenity Exterior	37.50 m <sup>2</sup>
Level 1	Private Garden	Amenity Exterior	50.87 m <sup>2</sup>
Level 1	Children's Play	Amenity Exterior	189.66 m <sup>2</sup>
Level 1	Games Lounge	Amenity Interior	66.34 m <sup>2</sup>
Level 1	Flexible Seating	Amenity Interior	50.83 m <sup>2</sup>
Level 1	Art's + Activities	Amenity Interior	116.55 m <sup>2</sup>
Level 1	WFI	Amenity Interior	40.01 m <sup>2</sup>
Level 1	Wellness	Amenity Interior	50.02 m <sup>2</sup>
Level 1	Bookable	Amenity Interior	27.72 m <sup>2</sup>
Level 1	Resident Terrace	Amenity Exterior	141.19 m <sup>2</sup>
Level 7	Quiet Seating	Amenity Interior	73.12 m <sup>2</sup>
Grand total:	13		962.21 m <sup>2</sup>

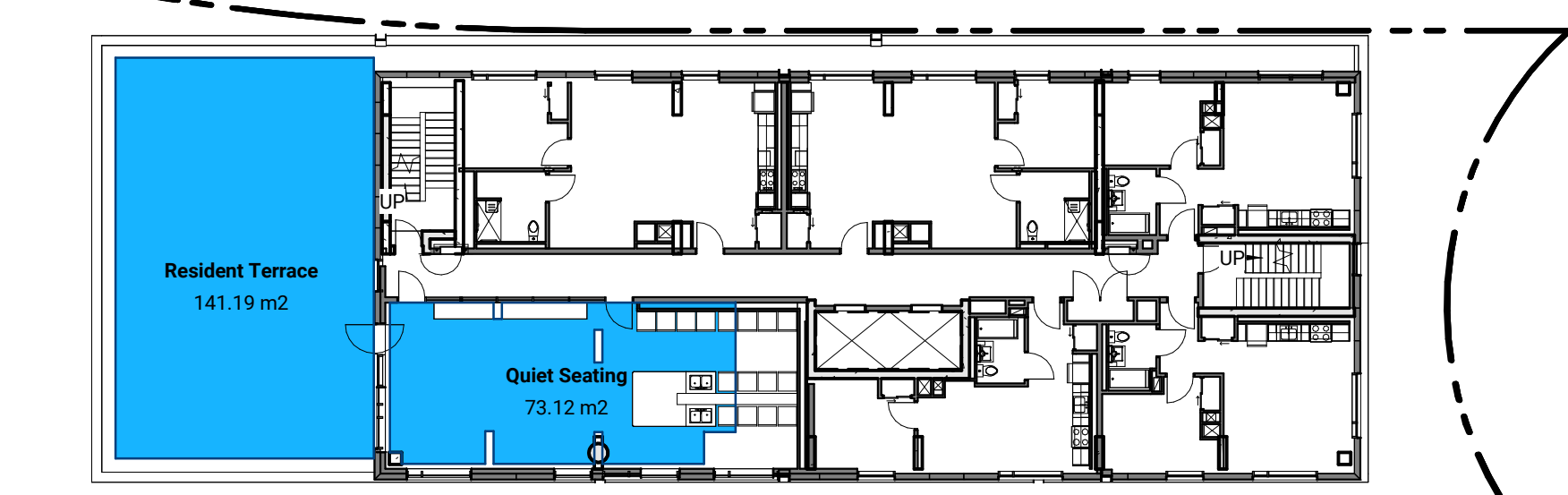

Level 7 Amenity Area Plan  
1:250 A040

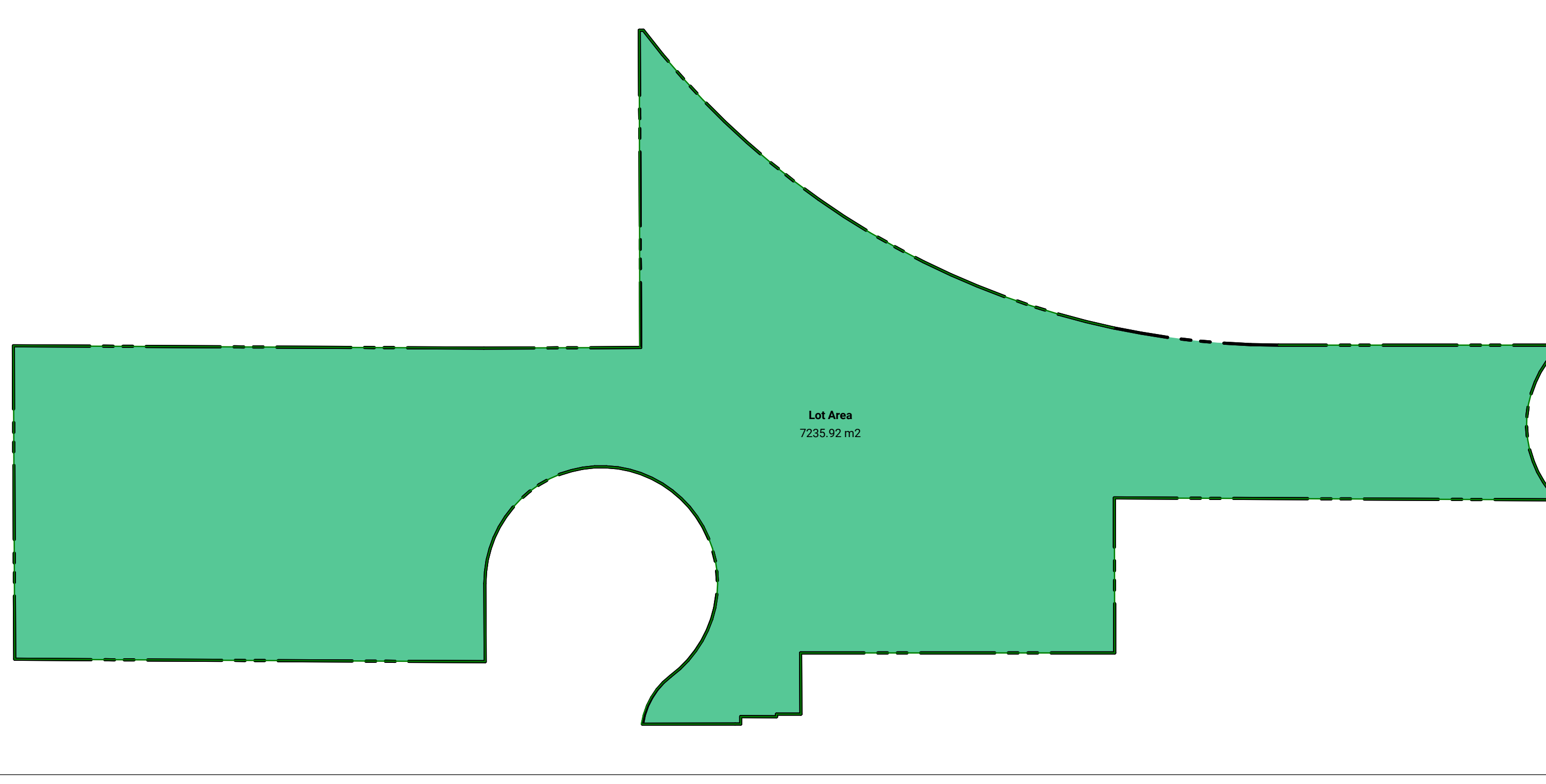

Lot Area  
1:500 A040

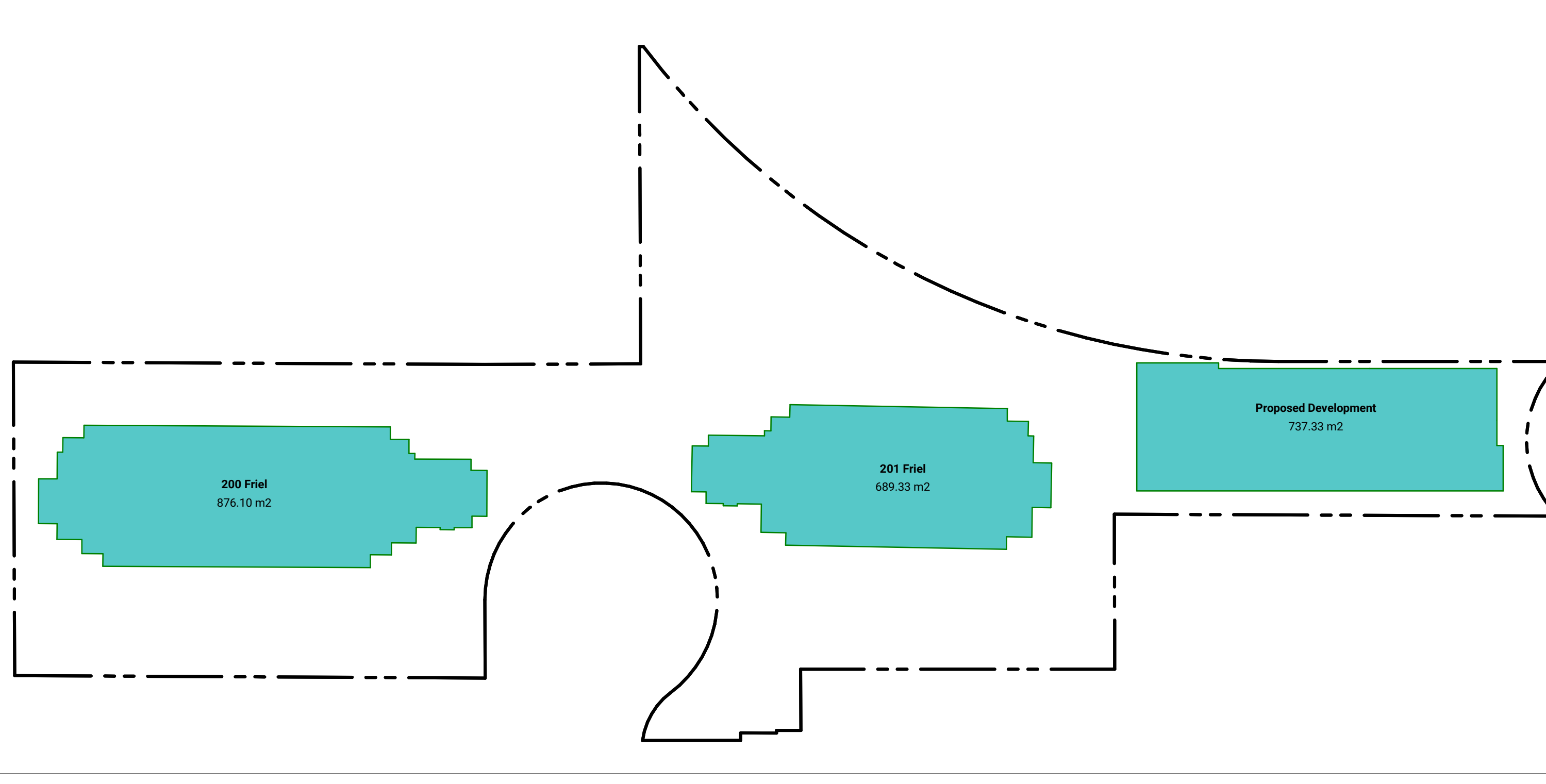

Lot Coverage  
1:500 A040

No.	Date	Description
1	22 MAR 2023	Issued for Rezoning and Site Plan Control
2	18 MAY 2023	Issued for Rezoning and Site Plan Control - Resubmission #1

NOT FOR CONSTRUCTION



Contractor Must Check & Verify all Dimensions on the Job.  
Do Not Scale Drawings.  
All Drawings, Specifications and Related Documents are the Copyright Property of the Architect and shall be returned upon Request. Reproduction or Circulation, Distribution and/or Release of any Documents in Part or in Whole is Prohibited without the Written permission of the Architect.  
This Drawing is Not to be Used for Construction Until Signed by the Architect.

OCH Friel Street / Chapel  
200-201 Friel Street, Ottawa, ON K1  
221021

Building Statistics  
As Indicated  
**A040**

- GENERAL NOTES**
- Plan Symbols**
- Denotes Sloped Roof Insulation
  - Denotes Roof Drain
  - Denotes Floor Drain
  - Denotes Area Drain
  - Denotes Hose Bib Location
  - Denotes Proposed Staircase Connection Location
  - Denotes Proposed Gas Meter Location
  - Denotes Rain Water Leader
  - Convex Mirror

- GENERAL NOTES**
- Plans**
1. Refer to Building Elements Schedule for Exterior Wall, Partition, Roof, Ceiling, and Soffit Types.
  2. Refer to Mechanical and Electrical Drawings for Additional Requirement.
  3. At Locations Where Mech. Ducts Interfere with Full Height Construction of Interior Partitions, Offset Partitions Above Ceiling and Brace as Required. Maintain Fire Separation/Smoke Rating of Partition. Offsetting of Partitions Will Only Be Permitted Where Ductwork Cannot be Positioned.
  4. All Dimensions are Taken to Face of Masonry or Concrete at Masonry and Concrete Walls and Partitions. At Steel Stud Partitions, Dimensions are Taken to Face of Gypsum Board, Unless Otherwise Noted.
  5. Increase Thickness of Walls or Fur Out Wall Thickness as Required to Accommodate Mechanical and Electrical Panels and Services. Maintain Fire Separation Around Back of Panels Where Applicable.
  6. For Dimensions of Concrete Refer to Slab Edge Drawings.

**Issued**

No.	Date	Description
1	22 MAR 2023	Issued for Rezoning and Site Plan Control
2	18 MAY 2023	Issued for Rezoning and Site Plan Control - Resubmission #1

**Proposed Parking Supply**

Type	Count
OCH Parking	2
Residential Parking	2
Visitor Parking	4
<b>Total</b>	<b>8</b>

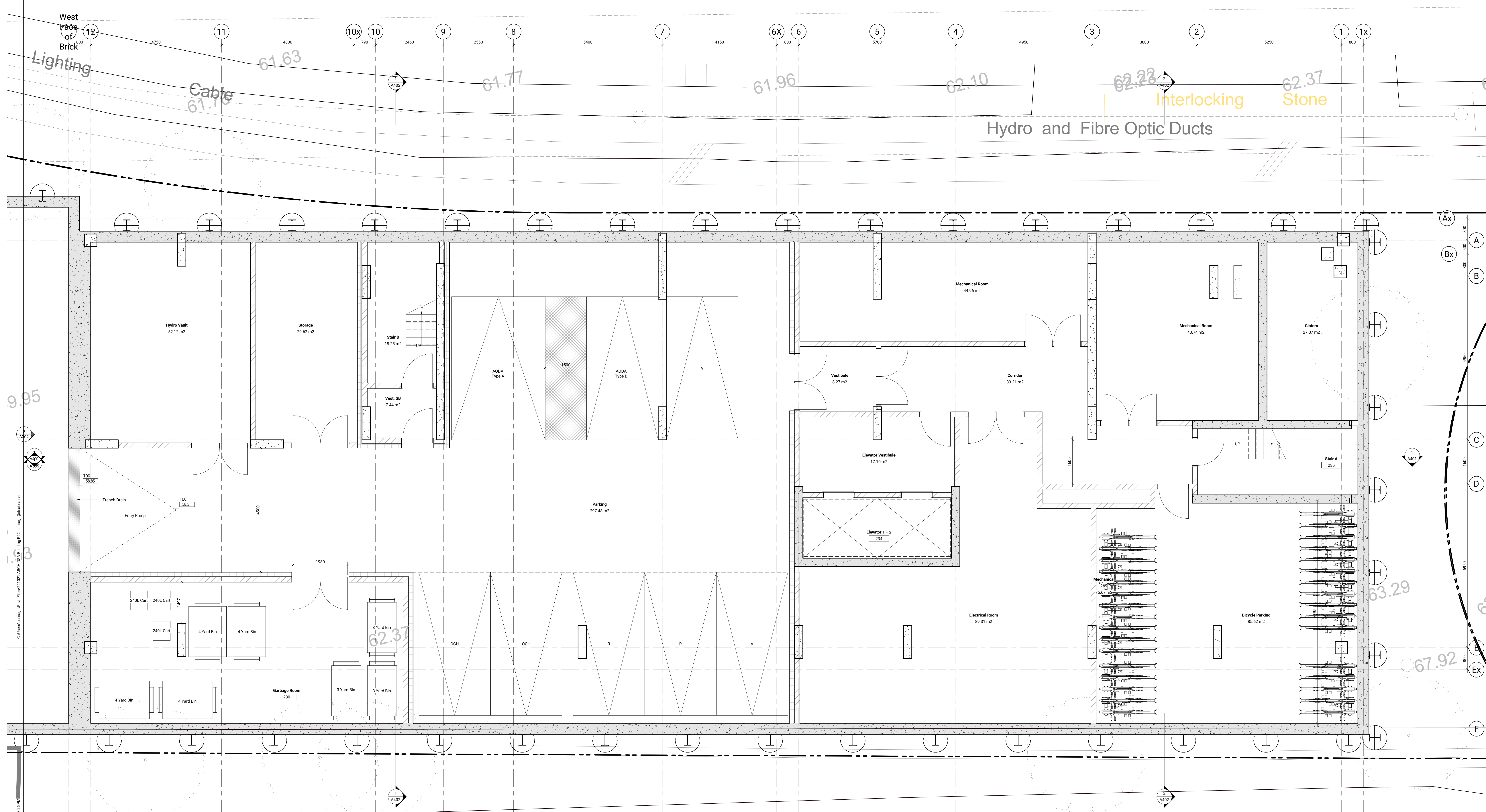

**NOT FOR CONSTRUCTION**

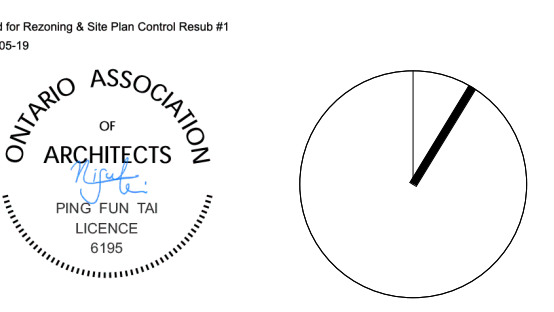

Contractor Must Check & Verify all Dimensions on the Job.  
 Do Not Scale Drawings.  
 All Drawings, Specifications and Related Documents are the Copyright Property of the Architect and Must be Returned Upon Request. Reproduction, Copying, Distribution and Release of any Part or in Whole is Prohibited Without the Written Permission of the Architect.  
 This Drawing is Not to be Used for Construction Until Signed by the Architect.

OCH Friel Street / Chapel  
 200-201 Friel Street, Ottawa, ON K1P 1Y1  
 2210211

**Basement Floor Plan**  
 As Indicated  
**A100-A**

**Basement Floor Plan**  
 1:50

2023-05-18 10:07:28 AM

- GENERAL NOTES**  
**Plan Symbols**
- Denotes Sloped Roof Insulation
  - Denotes Roof Drain
  - Denotes Floor Drain
  - Denotes Area Drain
  - Denotes Hose Bib Location
  - Denotes Proposed Staircase Connection Location
  - Denotes Proposed Gas Meter Location
  - Denotes Rain Water Leader
  - Convex Mirror

- GENERAL NOTES**  
**Plans**
1. Refer to Building Elements Schedule for Exterior Wall, Partition, Roof, Ceiling, and Soffit Types.
  2. Refer to Mechanical and Electrical Drawings for Additional Requirement.
  3. At Locations Where Mech. Ducts Interfere with Full Height Construction of Interior Partitions, Offset Partition Above Ceiling and Brace as Required. Maintain Fire Separation/Smoke Rating of Partition. Offsetting of Partitions Will Only Be Permitted Where Ductwork Cannot be Positioned.
  4. All Dimensions are Taken to Face of Masonry or Concrete at Masonry and Concrete Walls and Partitions. At Steel Stud Partitions, Dimensions are Taken to Face of Gypsum Board, Unless Otherwise Noted.
  5. Increase Thickness of Walls or Fur Out Wall Thickness as Required to Accommodate Mechanical and Electrical Panels and Services. Maintain Fire Separation Around Back of Panels Where Applicable.
  6. For Dimensions of Concrete Refer to Slab Edge Drawings.

No.	Date	Description
1	22 MAR 2023	Issued for Rezonning and Site Plan Control
2	18 MAY 2023	Issued for Rezonning and Site Plan Control - Resubmission #1

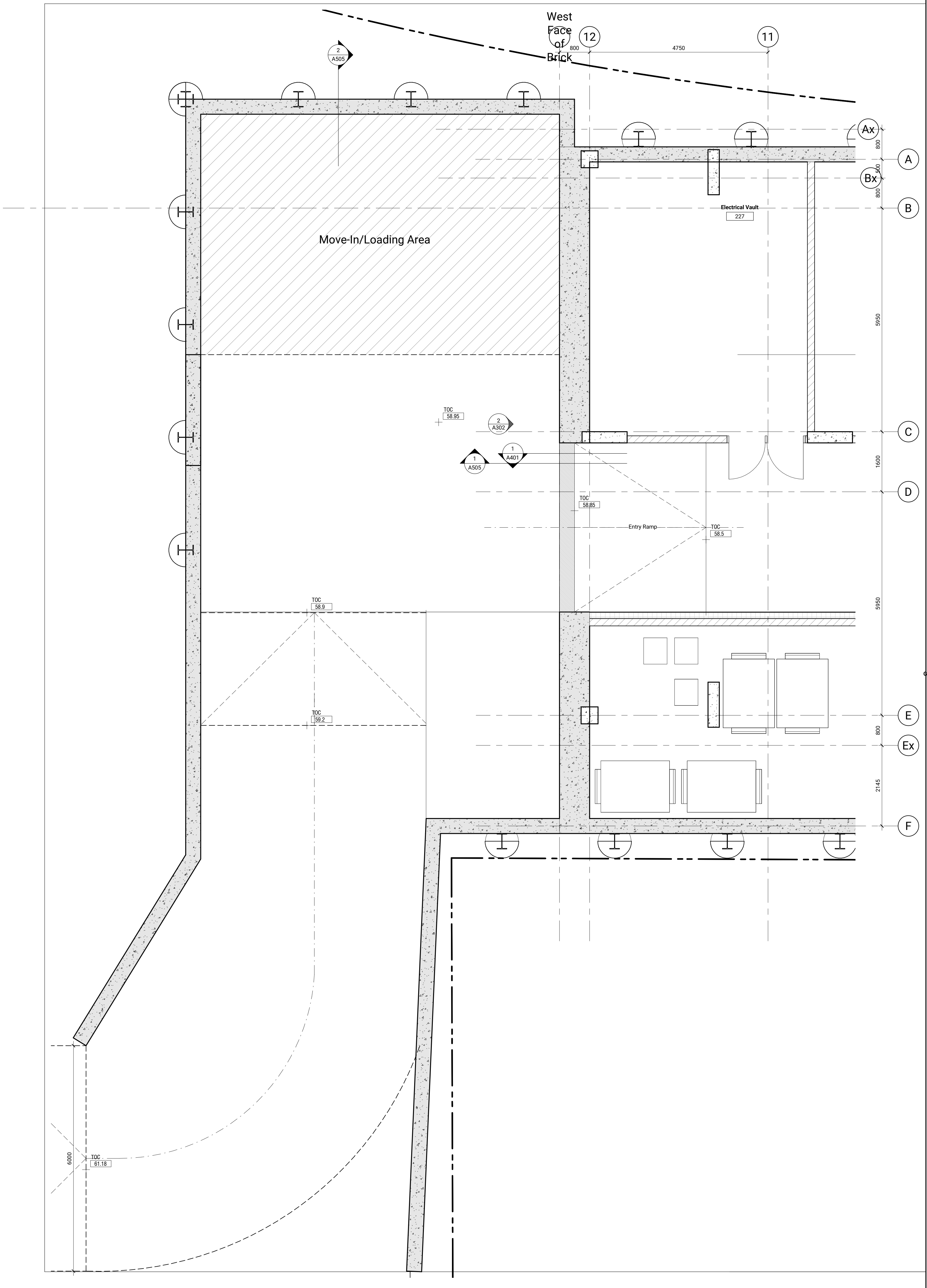

Garbage Room  
230

**NOT FOR CONSTRUCTION**



Contractor Must Check & Verify all Dimensions on the Job.  
 Do Not Scale Drawings.  
 All Drawings, Specifications and Related Documents are the Copyright Property of the Architect and Must be Returned Upon Request. Reproduction or Copying, Distribution or Release Constitutes Part or in Whole a Violation Without the Written permission of the Architect.  
 This Drawing is Not to be Used for Construction Until Signed by the Architect.

OCH Friel Street / Chapel  
 200-201 Friel Street, Ottawa, ON K1P 1Y1  
 221021

Basement + Loading Area Plan  
 As Indicated

**A100-B**  
 007-12-25-0034 (SFC)

Basement + Loading Zone  
 1:50

2023-05-18 10:07:37 AM C:\Users\jstange\OneDrive\Files\2321021\_ARCH\04\_Bldg\02\_Auripage\04.dwg

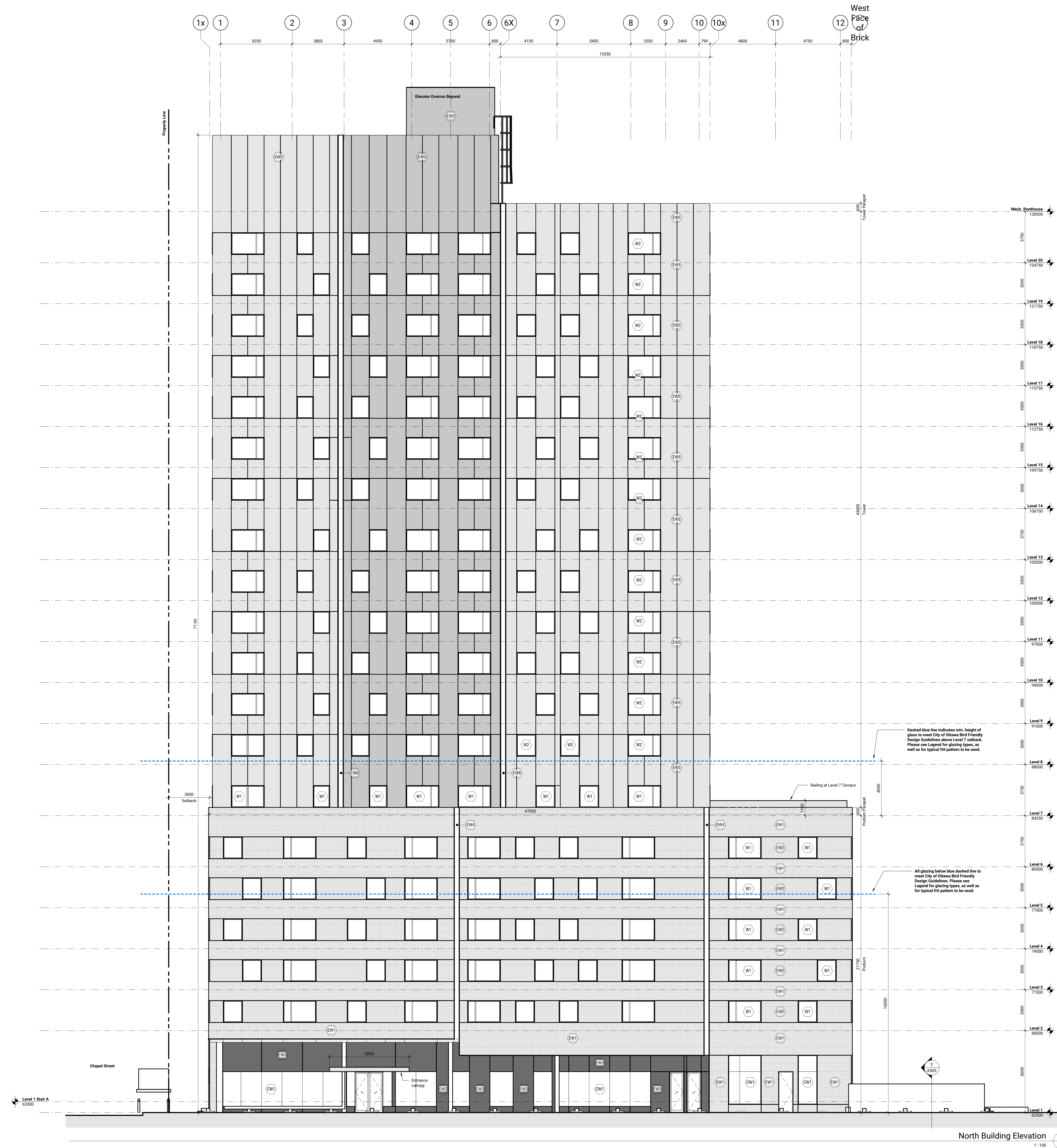

No.	Date	Description
1	22 MAR 2023	Issued for Rezoning and Site Plan Control
2	18 MAY 2023	Issued for Rezoning and Site Plan Control - Resubmission #1

**Legend - Cladding Materials**

(EW1)	Exterior Wall Type 1 - Masonry Cladding
(EW2)	Exterior Wall Type 2 - Masonry/Precast Cladding
(EW3)	Exterior Wall Type 3 - Smoored Stone Cladding
(EW4)	Exterior Wall Type 4 - Coloured Masonry Cladding
(EW5)	Exterior Wall Type 5 - Metal Panel Cladding
(EW6)	Exterior Wall Type 6 - Coloured Metal Panel Cladding
(CW1)	Curtain Wall Type 1 - Triple Glazed Curtain Wall Bird-Friendly Frit on Surface #1 to meet Ottawa Bird-Friendly Design Guidelines*
(W1)	Punched Window Type 1 - Triple Glazed Fibreglass Window Bird-Friendly Frit on Surface #1 to meet Ottawa Bird-Friendly Design Guidelines*
(W2)	Punched Window Type 2 - Triple Glazed Fibreglass Window Clear glazing without frit

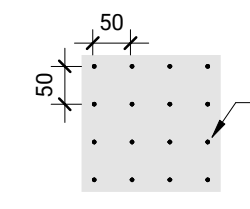
\*Bird-friendly frit pattern:  
  
 Bird-friendly frit pattern to be installed on Surface #1, to meet the layout illustrated below, as well as requirements noted in Div. 08 and Ottawa Bird-Friendly Design Guidelines.

**NOT FOR CONSTRUCTION**



Contractor Must Check & Verify all Dimensions on the Job.  
 Do Not Scale Drawings.  
 All Drawings, Specifications and Related Documents are the Copyright Property of the Architect and Must be Returned Upon Request. Reproduction or Drawing, Distribution and Release of any Documents or Parts in Whole or in Part is Prohibited Without the Written Permission of the Architect.  
 This Drawing is Not to be Used for Construction Until Signed by the Architect.

OCH Friel Street / Chapel  
 200-201 Friel Street, Ottawa, ON K1P 2T1

North Exterior Building Elevation  
 As indicated  
**A301**

007-12-25-0034 (SPC)

Ax A Bx B C D E Ex F  
 800 500 800 5950 1600 5950 800

F Ex E D C B Bx A Ax  
 800 5950 1600 5950 800 500 800

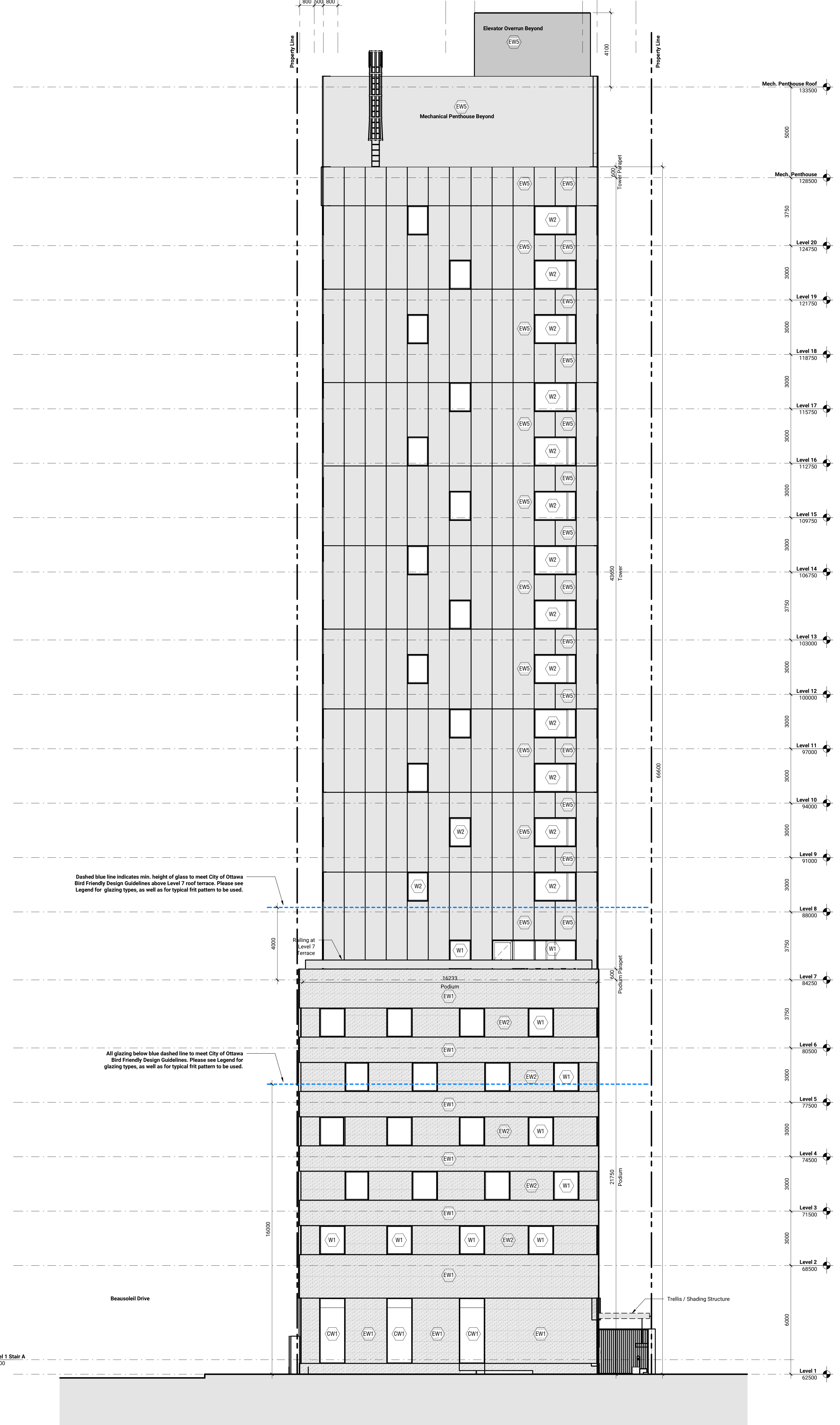

West Building Elevation  
 1:100

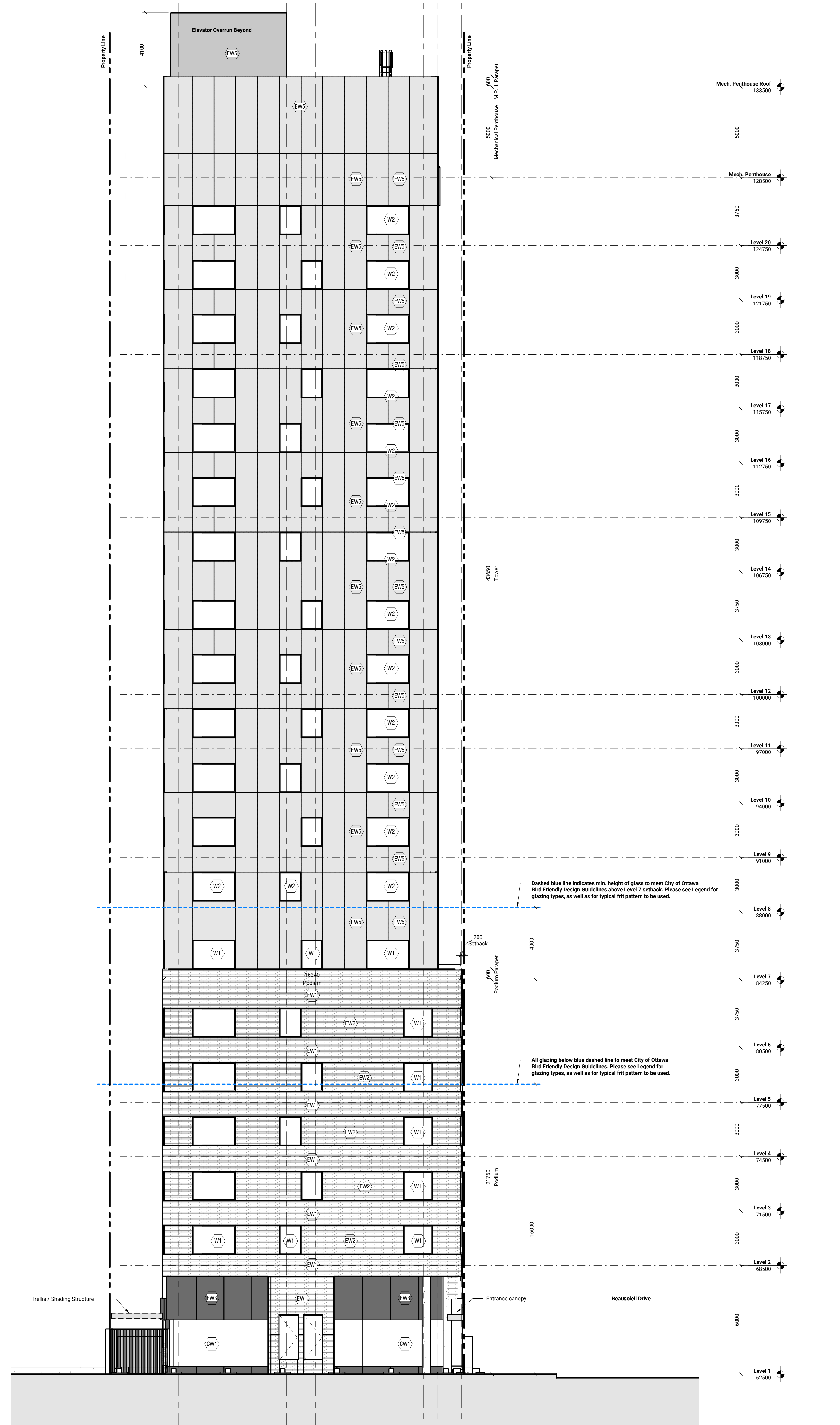

East Building Elevation  
 1:100

Issued

No.	Date	Description
1	22 MAR 2023	Issued for Rezoning and Site Plan Control
2	18 MAY 2023	Issued for Rezoning and Site Plan Control - Resubmission #1

- Legend - Cladding Materials
- (EW1) Exterior Wall Type 1 - Masonry Cladding
  - (EW2) Exterior Wall Type 2 - Masonry/Precast Cladding
  - (EW3) Exterior Wall Type 3 - Smoored Stone Cladding
  - (EW4) Exterior Wall Type 4 - Coloured Masonry Cladding
  - (EW5) Exterior Wall Type 5 - Metal Panel Cladding
  - (EW6) Exterior Wall Type 6 - Coloured Metal Panel Cladding
  - (CW1) Curtain Wall Type 1 - Triple Glazed Curtain Wall Bird Friendly Frit on Surface #1 to meet Ottawa Bird Friendly Design Guidelines\*
  - (W1) Punched Window Type 1 - Triple Glazed Fibreglass Window Bird Friendly Frit on Surface #1 to meet Ottawa Bird Friendly Design Guidelines\*
  - (W2) Punched Window Type 2 - Triple Glazed Fibreglass Window Clear glazing without frit

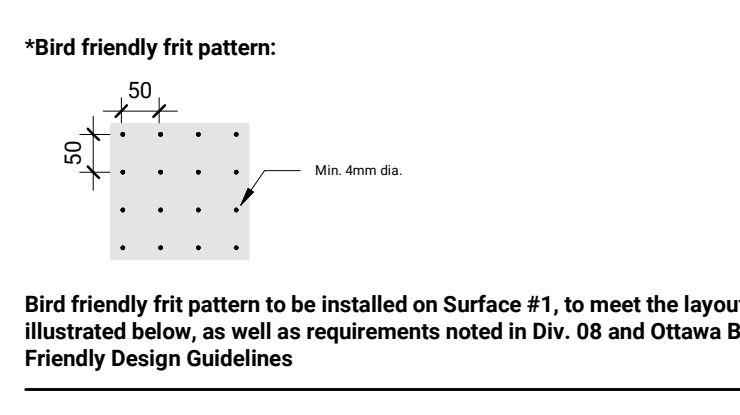

**NOT FOR CONSTRUCTION**

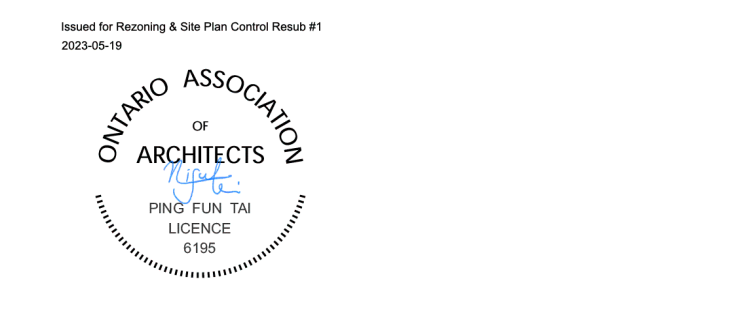

Contractor Must Check & Verify all Dimensions on the Job.  
 Do Not Scale Drawings.  
 All Drawings, Specifications and Related Documents are the Copyright Property of the Architect and shall be returned upon Request. Reproduction or Forwarding, Distribution and Release of any Part or Whole is Forbidden without the Written permission of the Architect.  
 This Drawing is Not to be Used for Construction Until Signed by the Architect.

OCH Friel Street / Chapel  
 200-201 Friel Street, Ottawa, ON K1P 2T1

East and West Exterior Building Elevations  
 As indicated

**A302**

2023-05-18 10:57:59 AM C:\Users\mangr\OneDrive\Files\2321021\ARCH\OCH Building 022\_A302.dwg (1 of 1) .csh



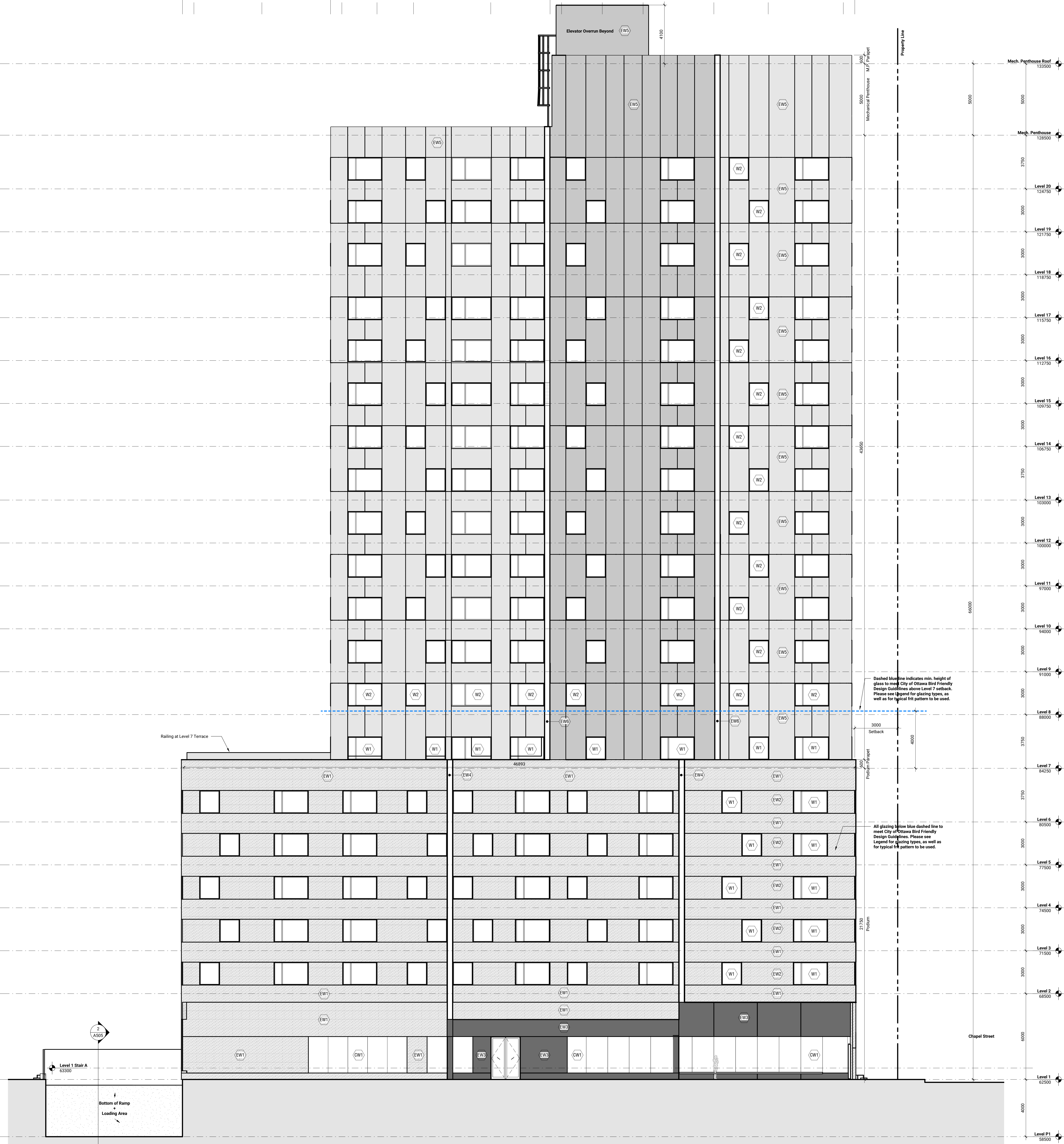
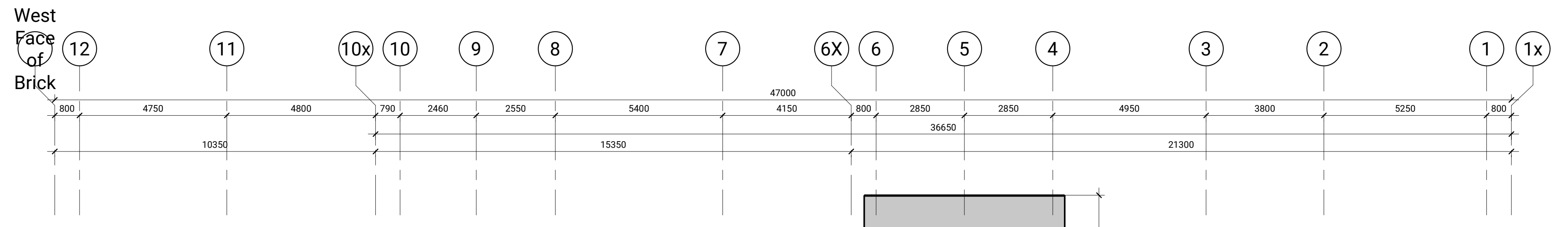

Issued

No.	Date	Description
1	22 MAR 2023	Issued for Rezoning and Site Plan Control
2	18 MAY 2023	Issued for Rezoning and Site Plan Control - Resubmission #1

Legend - Cladding Materials

EW1	Exterior Wall Type 1 - Masonry Cladding
EW2	Exterior Wall Type 2 - Masonry/Precast Cladding
EW3	Exterior Wall Type 3 - Smoored Stone Cladding
EW4	Exterior Wall Type 4 - Coloured Masonry Cladding
EW5	Exterior Wall Type 5 - Metal Panel Cladding
EW6	Exterior Wall Type 6 - Coloured Metal Panel Cladding
CW1	Curtain Wall Type 1 - Triple Glazed Curtain Wall Bird Friendly Frit on Surface #1 to meet Ottawa Bird Friendly Design Guidelines*
W1	Punched Window Type 1 - Triple Glazed Fibreglass Window Bird Friendly Frit on Surface #1 to meet Ottawa Bird Friendly Design Guidelines*
W2	Punched Window Type 2 - Triple Glazed Fibreglass Window Clear glazing without frit

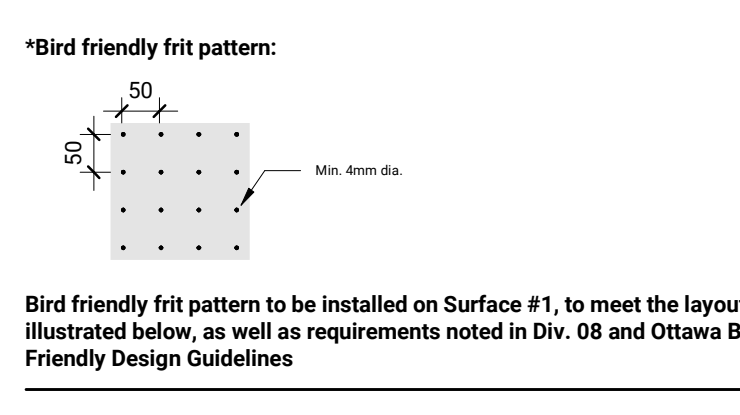

**NOT FOR CONSTRUCTION**



Contractor Must Check & Verify all Dimensions on the Job.  
Do Not Scale Drawings.  
All Drawings, Specifications and Related Documents are the Copyright Property of the Architect and Must be Returned Upon Request. Reproduction of Drawings, Specifications and Related Documents in Part or in Whole is Prohibited Without the Written Permission of the Architect.  
This Drawing is Not to be Used for Construction Until Signed by the Architect.

OCH Friel Street / Chapel  
200-201 Friel Street, Ottawa, ON K1P 2T1

South Exterior Building Elevation  
As Indicated  
**A303**

2023-05-11 10:08:02 PM