

LRL

ENGINEERING | INGÉNIERIE

Servicing Memo

Proposed Halo Car Wash
3095 Palladium Drive
Kanata, Ontario

Prepared for:

Halo Car Wash Inc.
18 Adelaide Street
Maxville, ON
K0C 1T0

Attention: Mr. Jordan Lupovici

LRL File No.: 230273

Revised March 04, 2024
June 16, 2023



1 INTRODUCTION AND SITE DESCRIPTION

LRL Associates Ltd. was retained by Halo Car Wash Inc. to complete a Site Servicing Memo for the construction of a Car Wash development located at 3095 Palladium Drive, Kanata, ON. The location of the proposed site can be viewed in Figure 1.



Figure 1: Aerial View of Proposed Development

The proposed development will consist of a Halo Tunnel Car Wash which will be accessible from a 9 m wide entrance located off Kanata West Centre Dr. Additional detail of the proposed development can be found on Site Plan (C201) included in Appendix E. The subject site measures approx. **0.536 ha** and is currently undeveloped, consisting of mostly grassed area. The existing site is relatively flat with the elevation ranging from 105.01 (northwest corner) to 104.62 (southwest corner). The infrastructures located within the adjacent right-of-way includes (i) 250 mm dia. Watermain, (ii) 200 mm dia. Sanitary sewer, and (iii) 825 mm dia. Storm sewer.

2 WATER SUPPLY

The subject site is proposed to be serviced via 100 mm dia. water servicing to be connected with the existing 250 mm dia. watermain located along the existing road in south end of the site. Estimated water demand for the subject site is calculated based on the City of Ottawa Design guidelines and anticipated water use by Car Wash, as follows.

- Average Day Demand = **1.30 L/s**
- Maximum Day Demand = **2.29 L/s**
- Peak Hour Demand = **6.72 L/s**



The estimated fire flow of the proposed building is calculated **85 L/s** in accordance with Fire Underwriters Survey (FUS) method. Refer to Appendix B for calculation details.

Based on the hydraulic analysis performed by Robinson Consultant Inc., the maximum pressure simulation exceeds 80 psi, therefore, a pressure reducing valve (PRV) is required at the service entry of Halo Building.

3 SANITARY SERVICE

The subject site is proposed to be serviced with 150 mm dia. sanitary sewer to be connected with the existing 200 mm dia. sanitary sewer located along the existing road in the south end of the proposed site. The parameters used to calculate the anticipated sanitary flows were adopted from the City of Ottawa design parameters as well as anticipated car wash water uses. The total anticipated sanitary flow is estimated **6.32 L/s**. Refer to Appendix C for sanitary sewer design sheet.

4 STORMWATER MANAGEMENT

The subject site is proposed to be serviced with 375 mm dia. storm sewer to be connected with the existing 825 mm dia. storm sewer along the existing road in the south end of the subject site. The design criteria for this development is based on pre-consultation meeting with the City of Ottawa officials, the City of Ottawa Sewer Design Guidelines, 2012 (City standards), as well as the Ministry of the Environment's Stormwater Management, Planning and Design Manual, 2003. The allowable release for the subject site is **105.00 L/s** as determined by Robinson Consultants Inc.

Post-development storm events up to and including 100-yr storm events will be controlled by using an Inlet Control Device (ICD)-John Meunier 250VHV-2 (or approved equivalent). Storage required, as a result of quantity control, will be achieved through parking lot storage. Table 1 shows summary of release rates, required storage and available on-site storage, calculations can be found in Appendix D. For the proposed controlled/uncontrolled areas, refer to Post-development Watershed Plan C702 in Appendix E.



Table 1: Summary of Release Rates and Storage

Catchments	Area (ha)	Release Rate (L/s)		Storage Required (m ³)		Storage Provided (m ³)
		100-yr	5-yr	100-yr	5-yr	
Controlled (WS-01 to WS-06)	0.445	78.51	78.51	67.25	6.28	74.97
Uncontrolled (WS-07 to WS-10)	0.090	26.49	12.37	N/A	N/A	N/A
Total	0.536	105.00	90.88	67.25	6.28	74.97

The runoff exceeding the allowable release rate will be stored on-site via surficial ponding and underground storage. For 100-yr storm event, it is calculated that a total of **67.25 m³** of storage will be required to attenuate flows to the allowable release rate of **78.51 L/s** (controlled release). The total surface storage provided is **74.97 m³**, thus exceeds the required storage.

The required storage of **15.80 m³** for 2-yr storm will be accommodated underground (i.e. no ponding) in oversized pipe and CB/CBMH structures which will provide a total available storage of **21.10 m³**. It is important to note that an average release rate of **39.26 L/s** (50% of maximum controlled release rate) was used in underground storage calculation for 2-yr storm (Appendix D). Storm events greater than 100-yr will flow overland towards Right-of-Way. The maximum ponding elevation and depths can be found on Stormwater Management Plan C601 (Appendix E).

Based on pre-consultation meeting notes, the stormwater quality control will be achieved in the downstream stormwater management facility, a storm pond (Pond 6 West).

5 REPORT CONDITIONS AND LIMITATIONS

The memo conclusions are applicable only to this specific project described in the preceding pages. Any changes, modifications or additions will require a subsequent review by LRL Associates Ltd. to ensure the compatibility with the recommendations contained in this document. If you have any questions or comments, please contact the undersigned.



Prepared by:
LRL Associates Ltd.

Maxime Longtin

Maxime Longtin
Civil Engineering Technologist



Mohan Basnet, P.Eng.
Civil Engineer



APPENDIX A

Pre-consultation / Correspondance

Pre-Application Consultation Meeting Notes

Property Address: 3095 Palladium Drive
PC2023-0026

February 9, 2023 – Teams Meeting

Attendees:

Dave Melkie, Quaestus
Barry Godfrey, Quaestus
Tim Eisner, JFSA
Jocelyn Chandler, JFSA
Allan Stone, Architect
Andrew Harte, CGH Transportation
Derek Howe, Taggart
Dave Meikle, DBM Consulting
Chris Collins, EXP Engineering
Molly Smith, Planner II
Alex Gatien, Planner I
Selma Hassan, Urban Design
Laura Hagerman, Parks Planning
Kimberley Baldwin, Parks Planning
Mark Elliot, Environmental Planning
Shika Rathnasooriya, Infrastructure Project Manager
Josiane Gervais, Transportation Project Manager

Regrets: Nancy Young, Forestry

Subject: 3095 Palladium Retail Development.

Meeting notes:

Overview of Proposal

- The proposal is for a multi-tenant shopping centre on roughly the northern two thirds of the site with a car wash on the southern portion of the site. The site is located at the southwest corner of the intersection of Palladium Drive and Campeau Drive.
- The development will require a site plan control application and plan of condominium. Zoning By-law Amendment to permit a car wash is being contemplated.
- The intention is to apply for an ZBA and SPC concurrently. Current OP policies may make the introduction of a car wash difficult to support.
- The intention is to apply for SPC for the neighbouring site to the west (3075 Palladium) at roughly the same time. The neighbouring site is under different ownership but same consulting team.

- Site is part of a previous plan of subdivision and site plan control application (D07-12-15-0016 and D07-12-16-0122). Conditions on page 40 of the subdivision agreement relate to the left turning lane on Palladium Drive, relevant to the application.

Preliminary comments and questions from staff and agencies, including follow-up actions:

- **Planning**

- The site is designated as Neighbourhood in the Suburban West Transect of the Official Plan.
- The language in the official plan requires applications to meet the full intention and policies of Section 6.3 – Neighbourhoods. This designation has strict requirements for what kind of non-residential uses are permitted and the design. All policies that speak to non-residential uses must be met due to the language of ‘shall’ instead of ‘should’
 - Specifically policies for non-residential uses:
 - 6.3.1
 - 6.3.2
 - 6.3.3
 - The applicant is encouraged to discuss with staff if the car wash is viable after a redesign to address OP policies. The current design of the car wash would not be supported.
- With the current concept plan, can’t comments on any zoning deficiencies. Please include a full zoning statistics table on the site plan upon submission.
- Ensure sidewalk connections exist, especially to nearby transit stops.
- Maximize tree planting and landscaping. Ensure that there is adequate tree planting space, especially along the perimeter of the site and within parking lot islands.
- Please keep in mind that once Bill 109 is enacted (July 1st 2023), multiple planning applications cannot be filed at the same time. Ex. Rezoning and Site Plan Control – a rezoning would need to complete the appeal period before a site plan application can be filed.

- **Urban Design**

- A Design Brief is required. A Terms of Reference for the Brief is attached. All elements highlighted in yellow must be addressed in written and graphic format.
- The City’s Urban Design Guidelines for Large Format Retail apply to this site. The Design Brief is to address these guidelines and, in particular, focus on a response to the guidelines related to building orientation and interface with the public realm, treatment of blank walls and service areas, and landscaping. Please note that the quoted recommended soil volume for trees may be out of date and Forestry’s current standards are to apply.
- As noted in the guidelines, such plazas are to address the street as much as possible through:
 - Entrances on the street
 - Real windows on the street
 - Corner units with glazing that wraps the unit and faces the street
 - Use of architectural elements and colour to animate the street
 - Landscaping

These elements are to be addressed in the submitted drawings and Design Brief.
- Should the applicant pursue the carwash, the City’s Urban Design Guidelines for Drive-throughs must also be addressed in the Design Brief.

- Older retail plazas in the City are undergoing redevelopment and intensification. All new plazas are to be designed considering the logical evolution of the site (as note in the Design Guidelines). If the applicant does not pursue the car wash and the entire site develops as a large format retail, the applicant is asked to provide alternate layouts that considers the site as a whole, shows how the two parcels would work together now and with future redevelopment / intensification.
 - The submitted Site and Landscape Plans are to clearly show the location and width of pedestrian walkways within the site, as well as walkway connections to the public sidewalks around the site.
 - The submitted Site and Landscape Plan are to show the locations of all primary and exit doors.
 - Site landscaping will be important. The applicant's landscape architect is to include robust tree planting within and surrounding the site. The submitted drawings must indicate the soil volumes provided and show planting details for hard and soft surface conditions. The selected species must be successful in urban conditions (salt, drought, compaction).
 - If the car wash is pursued, the applicant is asked to provide alternate layouts that would internalize the cueing lanes and provide built form parallel and adjacent to the ROW.
- **Engineering**
 - The Servicing Study Guidelines for Development Applications are available at the following address: <https://ottawa.ca/en/planning-development-and-construction/developing-property/development-application-review-process/development-application-submission/guide-preparing-studies-and-plans#servicing-study-guidelines-development-applications>
 - Servicing and site works shall be in accordance with the following documents:
 - Ottawa Sewer Design Guidelines (October 2012)
 - Ottawa Design Guidelines – Water Distribution (2010)
 - Geotechnical Investigation and Reporting Guidelines for Development Applications in the City of Ottawa (2007)
 - City of Ottawa Slope Stability Guidelines for Development Applications (revised 2012)
 - City of Ottawa Environmental Noise Control Guidelines (January 2016)
 - City of Ottawa Park and Pathway Development Manual (2012)
 - City of Ottawa Accessibility Design Standards (2012)
 - Ottawa Standard Tender Documents (latest version)
 - Ontario Provincial Standards for Roads & Public Works (2013)
 - Record drawings and utility plans are also available for purchase from the City (Contact the City's Information Centre by email at InformationCentre@ottawa.ca or by phone at (613) 580-2424 x.44455).
 - Watermain Infrastructure:
 - a) There are available 200mm and 250mm diameter private PVC watermains located the subdivision. A water boundary condition request is needed for the proposed water connection to the City main.
 - b) As per Section 4.4.7.2 of the Ottawa Design Guidelines – Water Distribution, a DMA (District Metering Area) chamber will be required for private developments serviced by a connection 150mm or larger.
 - c) Water Boundary condition requests must include the location of the service and the expected loads required by the proposed development. Please provide an email to Shika Rathnasooriya (Thakshika.Rathnasooriya@ottawa.ca) with the following information:

- i. Location of service
 - ii. Type of development and the amount of fire flow required (as per FUS, 1999 – See technical bulletin ISTB 2021-03).
 - iii. Average daily demand: ___ l/s.
 - iv. Maximum daily demand: ___ l/s.
 - v. Maximum hourly daily demand: ___ l/s.
- Sanitary / Storm Infrastructure:
 - a) There are available 200mm and 300mm diameter PVC and concrete sanitary sewers located southeast and southwest of the proposed site.
 - b) All services (STM, SAN, WTR) should be grouped in a common trench to minimize the number of road cuts.
 - c) Sewer connections to be made above the springline of the sewermain as per:
 - i. Std Dwg S11.1 for flexible main sewers.
 - ii. Std Dwg S11 (For rigid main sewers).
 - iii. Std Dwg S11.2 (for rigid main sewers using bell end insert method).
 - iv. Connections to manholes permitted when the connection is to rigid main sewers where the lateral exceeds 50% the diameter of the sewermain. – Connect obvert to obvert with the outlet pipe unless pipes are a similar size.
- The Stormwater Management Criteria, for the subject site, is to be based on the following:
 - a) The 5-yr and 100-yr post development peak flows for the development area are to be controlled to a release rate identified in the 'Design Brief , Kanata West Retail Centre 3015, 3075 and 3095 Palladium Drive' dated 2016. Onsite storage is to be provided for storm events up to and including the 100-yr storm event.
 - b) There should be no stormwater ponding in parking areas or drive aisles during the 2-year storm event.
 - c) Quality control to be provided by Pond 6 West.
 - d) Infiltration targets maybe required for the site.
 - e) The design of the storm sewers in the area are based on a 5-yr storm. If discharging to a storm sewer, the SWM criteria is to be based on the following for the development area:
 - i. The 5-yr storm event using the IDF information derived from the Meteorological Services of Canada rainfall data, taken from the MacDonald Cartier Airport, collected 1966 to 1997.
 - ii. The pre-development runoff coefficient or a maximum equivalent 'C' of 0.5, whichever is less.
 - iii. A calculated time of concentration (Cannot be less than 10 minutes).
 - iv. Flows to the storm sewer in excess of the 5-yr storm release rate, up to and including the 100-year storm event, must be detained on site.
- MECP ECA Requirements:

An MECP Environmental Compliance Approval (Private Sewage Works) will be required for the proposed development due to the proposed car wash.

- Phase 1 ESAs and Phase 2 ESAs must conform to clause 4.8.4 of the Official Plan that requires that development applications conform to Ontario Regulation 153/04.

- **Transportation**

- Follow Transportation Impact Assessment Guidelines:
 - A TIA is required. Please submit the Scoping report to Josiane.gervais@ottawa.ca at your earliest convenience.
 - Start this process asap. The application will not be deemed complete until the submission of the draft step 1-4, including the functional draft RMA package (if applicable) and/or monitoring report (if applicable).
 - Request base mapping asap if RMA is required. Contact Engineering Services (<https://ottawa.ca/en/city-hall/planning-and-development/engineering-services>)
 - As discussed, please ensure the TIA addresses the operations at the NB-LT lane on Palladium and how the operations relate to the subdivision condition to close the left-turn lane.
 - A joint TIA study for both 3095 and 3075 Palladium could be considered by the City provided that the timelines of both applications align. Separate title pages/introductions would be required for the individual applications. The iterative steps of the TIA must be followed. Any costs/delays resulting from providing both studies together would be the applicant's responsibility.
- TMP shows future LRT station at Huntmar Drive (Ultimate Concept).
- As the proposed site is commercial and for general public use, AODA legislation applies.
 - Ensure all crosswalks located internally on the site provide a TWSI at the depressed curb, per requirements of the Integrated Accessibility Standards Regulation under the AODA.
 - Clearly define accessible parking stalls and ensure they meet AODA standards (include an access aisle next to the parking stall and a pedestrian curb ramp at the end of the access aisle, as required).
 - Please consider using the City's Accessibility Design Standards, which provide a summary of AODA requirements. <https://ottawa.ca/en/city-hall/creating-equal-inclusive-and-diverse-city/accessibility-services/accessibility-design-standards-features#accessibility-design-standards>
- On site plan:
 - Ensure site access meets the City's Private Approach Bylaw.
 - Show all details of the roads abutting the site; include such items as pavement markings, accesses and/or sidewalks.
 - Turning movement diagrams required for all accesses showing the largest vehicle to access/egress the site.
 - Turning movement diagrams required for internal movements (loading areas, garbage).
 - Show all curb radii measurements; ensure that all curb radii are reduced as much as possible and fall within TAC guidelines (Figure 8.5.1).
 - Show dimensions for site elements (i.e. lane/aisle widths, access width and throat length, parking stalls, sidewalks, pedestrian pathways, etc.)
 - Parking stalls at the end of dead-end parking aisles require adequate turning around space

- **Environmental**

- Already had a comprehensive environmental review for the subdivision. Should include a note that they will be followed.
- Bird-Safe Design Guidelines should be incorporated into the design of the buildings to help reduce bird mortality in the presence of what will likely be substantial amounts of window coverage.
- Urban Heat Island
 - There is a lot of impermeable surface on the proposed plans, which would contribute to the urban heat island effect and extreme heat events. Please add features that reduce the urban heat island effect (see OP 10.3.3) produced by the parking lot and a building footprint. For example, this impact can be reduced by adding large canopy trees, green roofs or vegetation walls, or constructing the parking lot or building differently.
- Within the Carp river watershed, so there are runoff controls. Infrastructure comments address controls.
- ESA will need to be updated. Must be within 18 months of submission.

- **Forestry**

- A Tree Conservation Report and Landscape Plan are required, in accordance with the requirements below.
- There are trees planted around the perimeter of the property which must be retained and protected through the planning and development of the site. Appropriate setbacks and tree protection fencing locations must be shown on the TCR.
- The Landscape Plan must show where replacement and additional trees will be planted, with a priority of planting large-growing native species, to work towards 40% canopy cover.

Tree Conservation Report requirements:

1. A Tree Conservation Report (TCR) must be supplied for review along with the suite of other plans/reports required by the City
 - a. an approved TCR is a requirement of Site Plan approval.
 - b. The TCR may be combined with the LP provided all information is supplied
2. Any removal of privately-owned trees 10cm or larger in diameter, or city-owned trees of any diameter requires a tree permit issued under the Tree Protection Bylaw (Bylaw 2020 – 340); the permit will be based on an approved TCR and made available at or near plan approval.
3. Compensation may be required for the removal of city owned trees.
4. The TCR must contain 2 separate plans:
 - a. Plan/Map 1 - show existing conditions with tree cover information
 - b. Plan/Map 2 - show proposed development with tree cover information
 - c. Please ensure retained trees are shown on the landscape plan
5. The TCR must list all trees on site, as well as off-site trees if the CRZ extends into the developed area, with information on the species, diameter and health condition
6. Please identify trees by ownership – private onsite, private on adjoining site, city owned, co-owned (trees on a property line)
7. If trees are to be removed, the TCR must clearly show where they are, and document the reason they cannot be retained
8. All retained trees must be shown, and all retained trees within the area impacted by the development process must be protected as per City guidelines available at [Tree Protection Specification](#) or by searching [Ottawa.ca](#)
 - a. the location of tree protection fencing must be shown on the plan

- b. show the critical root zone of the retained trees
9. The new Official Plan places a strong priority on retention of existing trees. All opportunities to retain protected trees must be considered in the design of plans to maintain and improve the existing canopy cover of the site.
10. For more information on the process or help with tree retention options, contact Nancy Young nancy.young@ottawa.ca or on [City of Ottawa](#)

Tree planting requirements:

The Official Plan requires that "On urban properties subject to site plan control or community planning permits, development shall create tree planting areas within the site and in the adjacent boulevard, as applicable, that meet the soil volume requirements in any applicable City standards or best management practices or in accordance with the recommendation of a Landscape Architect;"

The Landscape Plan (LP) must account for the following:

Minimum Setbacks

- 1.5m from sidewalks, MUP/cycle tracks, and water service laterals
 - 2.5m from curb
 - Conifers: 4.5m setback from curb, sidewalk or MUP/cycle track/pathway
 - Street Trees: 7.5m between large growing trees, 4m between small growing trees
- Park or open space planting: 10m spacing between trees, except where otherwise approved in naturalization / afforestation areas
 - Adhere to the relevant Hydro Ottawa or Hydro One planting guidelines (species and setbacks) in proximity to above and below-ground hydro

Tree specifications

- Minimum stock size: 50mm tree caliper for deciduous, 200cm height for coniferous.
- Maximize the use of large deciduous species wherever possible to maximize future canopy coverage
- Tree planting on city property shall be in accordance with the City of Ottawa's Tree Planting Specification and will include watering and warranty as described in the specification (can be provided by Forestry Services).
- Plant a diversity of native trees whenever possible
- No root barriers, dead-man anchor systems, or planters are permitted.
- No tree stakes unless necessary

Hard surface planting

- Curb style planter is highly recommended
- No grates are to be used and if guards are required, City of Ottawa standard (which can be provided) shall be used.
- Trees are to be planted at grade

Soil Volume

- Please document on the LP that adequate soil volumes can be met:

Tree Type/Size	Single Tree Soil Volume (m3)	Multiple Tree Soil Volume (m3/tree)
Ornamental	15	9
Columnar	15	9
Small	20	12
Medium	25	15
Large	30	18
Conifer	25	15

Please note that these soil volumes are not applicable in cases with Sensitive Marine Clay.

Sensitive Marine Clay

- Please follow the City's 2017 Tree Planting in Sensitive Marine Clay guidelines

• **Parks**

- CIL at the rate of 2% will be required unless proof of CIL payment during the subdivision registration is provided.

• **City Surveyor**

- The determination of property boundaries, minimum setbacks and other regulatory constraints are a critical component of development. An Ontario Land Surveyor (O.L.S.) needs to be consulted at the outset of a project to ensure properties are properly defined and can be used as the geospatial framework for the development.
- Topographic details may also be required for a project and should be either carried out by the O.L.S. that has provided the Legal Survey or done in consultation with the O.L.S. to ensure that the project is integrated to the appropriate control network.

Questions regarding the above requirements can be directed to the City's Surveyor, Bill Harper, at Bill.Harper@ottawa.ca

Submission requirements and fees

- Additional information regarding fees related to planning applications can be found [here](#).
- Plans are to be standard A1 size (594 mm x 841 mm) or Arch D size (609.6 mm x 914.4 mm) sheets, dimensioned in metric and utilizing an appropriate Metric scale (1:200, 1:250, 1:300, 1:400 or 1:500).
- All PDF submitted documents are to be unlocked and flattened.

Next steps

- Please reach out to Councillor Curry to discuss the proposal when ready.
- It is anticipated that, as a result of the *More Homes for Everyone Act, 2022*, for applications for site plan approval and zoning by-law amendments, new processes in respect of pre-application consultation will be in place as of January 1, 2023. The new processes are anticipated to require a multiple phase pre-application consultation approach before an application will be deemed complete. Applicants who have not filed a complete application by the effective date may be required to undertake further pre-application consultation(s) consistent with the provincial changes. The by-laws to be amended include By-law 2009-320, the Pre-Consultation By-law, By-law 2022-239, the planning fees by-law and By-law 2022-254, the Information and Materials for Planning Application By-law. The revisions are

anticipated to be before Council in the period after the new Council takes office and the end of the year.

APPENDIX B
Water Supply Calculations



Water Service Calculations

LRL File No. : 230273

Project : Proposed Development - Halo Car Wash

Location : Palladium Drive, Kar

Date : May 17, 2023

Prepared by : M. Basnet

Water Demand

Site area = ha (Halo Car Wash)

Average day demand = 35000 L / ha · day (based on Table 4.2 of Ottawa Design Guidelines-Water Distribution)
= 18750 L / day
= 0.22 L / s

Maximum daily peak factor = 1.5
Maximum daily demand = 0.33 L / s

Maximum hour peak factor = 1.8
Maximum hour demand = 0.59 L / s

Adjustment - Car Wash

Estimated vol. of water/car wash = L

Average day demand = 93151 L / day (assuming 200000 car wash/year)
1.08 L / s

Maximum daily demand = 1.97 L / s (assuming 1000 car wash/day)

Maximum hour demand = 6.14 L / s (assuming 130 car wash/hour)

Total Anticipated Water Demand

Average day demand = 1.30 L/s
Maximum daily demand = 2.29 L/s
Maximum hour demand = 6.72 L/s



Fire Flow Calculations

LRL File No. 230273

Project: Proposed Development-Halo Car Wash

Location: Palladium Drive, Kanata, ON

Date: May 17, 2023

Method: Fire Underwriters Survey (FUS)

Prepared by: M. Basnet

Step	Task	Term	Options	Multiplier	Choose:	Value	Unit	Fire Flow	
Structural Framing Material									
1	Choose frame used for building	Coefficient C related to the type of construction	Wood Frame	1.5	Non-combustible Construction	0.8			
			Ordinary Construction	1.0					
			Non-combustible construction	0.8					
			Fire resistive construction <2 hrs	0.7					
			Fire resistive construction >2 hrs	0.6					
Floor Space Area (A)									
2			Total area			533	m ²		
3	Obtain fire flow before reductions	Required fire flow	$Fire\ Flow = 220 \times C \times A^{0.5}$				L/min	4,063	
Reductions or surcharge due to factors affecting burning									
4	Choose combustibility of contents	Occupancy hazard reduction or surcharge	Non-combustible	-25%	Combustible	0%	L/min	4,063	
			Limited combustible	-15%					
			Combustible	0%					
			Free burning	15%					
			Rapid burning	25%					
5	Choose reduction for sprinklers	Sprinkler reduction	Full automatic sprinklers	-30%	False	0%	L/min	4,063	
			Water supply is standard for both the system and fire department hose lines		-10%	False			0%
			Fully supervised system	-10%	False	0%			
6	Choose separation	Exposure distance between units	North side	0 to 3m	25%	25%	L/min	5,079	
			East side	>45m	0%				
			South side	>45m	0%				
			West side	>45m	0%				
Net required fire flow									
7	Obtain fire flow, duration, and volume	Minimum required fire flow rate (rounded to nearest 100)					L/min	5,100	
		Minimum required fire flow rate					L/s	85.0	
		Required duration of fire flow					hr	2	

APPENDIX C
Wastewater Calculations



LRL File No. 230273
Project: Proposed Development-Halo Car Wash
Location: 3095 Palladium Drive, Kanata (ON)
Date: February 15, 2024

Sanitary Design Parameters

Average Daily Flow = 280 L/p/day
 Commercial & Institutional Flow = 28000 L/ha/day
 Light Industrial Flow = 35000 L/ha/day
 Heavy Industrial Flow = 55000 L/ha/day
 Maximum Residential Peak Factor = 4.0
 Commercial & Institutional Peak Factor = 1.5

Industrial Peak Factor = as per Appendix 4-B
 Extraneous Flow = 0.33 L/s/gross ha
 (as Per Tech Bulletin ISTB-2018-01)

Pipe Design Parameters

Minimum Velocity = 0.60 m/s
 Manning's n = 0.013

LOCATION			RESIDENTIAL AREA AND POPULATION					COMMERCIAL		INDUSTRIAL			INSTITUTIONAL		C+I+I	INFILTRATION			TOTAL FLOW	PIPE						
STREET/SITE	FROM MH	TO MH	AREA (Ha)	POP.	CUMMULATIVE		PEAK FACT.	PEAK FLOW (l/s)	AREA (Ha)	ACCU. AREA (Ha)	AREA (Ha)	ACCU. AREA (Ha)	PEAK FACT.	AREA (Ha)	ACCU. AREA (Ha)	*PEAK FLOW (l/s)	TOTAL AREA (Ha)	ACCU. AREA (Ha)	INFILT. FLOW (l/s)	TOTAL FLOW (l/s)	LENGTH (m)	DIA. (mm)	SLOPE (%)	MATERIAL	CAP. (FULL) (l/s)	VEL. (FULL) (m/s)
					AREA (Ha)	POP.																				
	BLDG.	SAN MH03																		0.003	10.8	150	3.00%	PVC	26.38	1.49
	SAN MH03	SAN MH04																		0.003	9.1	150	3.00%	PVC	26.38	1.49
	SAN MH01	SAN MH02								0.536					6.139	0.536	0.536	0.177		6.316	34.9	150	1.50%	PVC	18.65	1.06
	SAN MH02	SAN MH04																		6.318	13.5	150	1.50%	PVC	18.65	1.06
	SAN MH04	SAN MH05																		6.318	23.3	150	1.50%	PVC	18.65	1.06
	SAN MH05	Ex. SAN																		6.318	10.9	150	2.93%	PVC	26.07	1.48
															Designed: M. B./M.L.		PROJECT: Proposed Halo Car Wash									
															Checked: M.B.		LOCATION: 3095 Palladium Drive, Kanata (ON)									
															Dwg. Reference: C401		File Ref.: 230273			Date: February 15, 2024			Sheet No. 1 of 1			

Note:
 **Peak flow including anticipated waste water from Halo Car Wash (6.141 L/s), see below

Site Description	Qty	L/Qty	Total	
			L/day	L/s
Halo Car Wash				
Anticipated Employees	2	75	150	0.002
Total x Peak Factor (1.5)				0.003
Estimated Car Wash/Hour (based on info by Halo Car Wash)	130	170		6.139
Total Anticipated Peak Design Flow (dry weather flow)				6.141

APPENDIX D
Stormwater Management Calculations

LRL Associates Ltd.

Storm Watershed Summary

	<p>LRL File No. 230273</p> <p>Project: Proposed Development-Halo Car Wash</p> <p>Location: 3095 Palladium Drive, Kanata</p> <p>Date: February 12, 2024</p> <p>Designed: M. Longtin</p> <p>Checked: M. Basnet</p> <p>Dwg Reference: C701, C702</p>
---	--

Pre-Development Catchments

Watershed	C = 0.20	C = 0.80	C = 0.90	Total Area (ha)	Combined C
EWS-01 (uncontrolled)	0.503	0.000	0.033	0.536	0.24
Total	0.503	0.000	0.033	0.536	0.24

Post-Development Catchments

Watershed	C = 0.20	C = 0.8	C = 0.90	Total Area (ha)	Combined C
WS-01 (controlled)	0.013	0.000	0.082	0.095	0.81
WS-02 (controlled)	0.000	0.000	0.062	0.062	0.90
WS-03 (controlled)	0.013	0.000	0.028	0.042	0.68
WS-04 (controlled)	0.088	0.000	0.085	0.172	0.54
WS-05 (controlled)	0.010	0.000	0.055	0.064	0.79
WS-06 (controlled)	0.012	0.000	0.000	0.012	0.20
WS-07 (uncontrolled)	0.008	0.000	0.014	0.022	0.65
WS-08 (uncontrolled)	0.008	0.000	0.006	0.015	0.50
WS-09 (uncontrolled)	0.022	0.000	0.014	0.037	0.48
WS-10 (uncontrolled)	0.016	0.000	0.001	0.017	0.22
Total	0.190	0.000	0.347	0.536	0.65



LRL File No. 230273
Project: Proposed Development-Halo Car Wash
Location: 3095 Palladium Drive, Kanata
Date: February 13, 2024
Designed: M. Longtin
Checked: M. Basnet
Drawing Ref.: C701, C702

**Stormwater Management
Design Sheet**

STORM - 100 YEAR

Runoff Equation

$Q = 2.78CIA$ (L/s)
 C = Runoff coefficient
 $I = \text{Rainfall intensity (mm/hr)} = A / (T_d + C)^B$
 A = Area (ha)
 $T_c = \text{Time of concentration (min)}$

Pre-development Catchment within Development Area

	Total Area =	0.536	ha	ΣR=	0.24
Uncontrolled	EWS-01	0.536	ha	R=	0.24
	Total Uncontrolled =	0.536	ha	ΣR=	0.24

Allowable Release Rate = 105.00 L/s (As determined by Robinsons Consultants Inc.)

Post-development Stormwater Management

					ΣR _{2&5}	ΣR ₁₀₀
Controlled	Total Site Area =	0.536	ha	ΣR=	0.65	0.82
	WS-01	0.095	ha	R=	0.81	1.00
	WS-02	0.062	ha	R=	0.90	1.00
	WS-03	0.042	ha	R=	0.68	0.85
	WS-04	0.172	ha	R=	0.54	0.68
	WS-05	0.064	ha	R=	0.79	0.99
	WS-06	0.012	ha	R=	0.20	0.25
	Total Controlled =	0.446	ha	ΣR=	0.69	0.86
Uncontrolled	WS-07	0.022	ha	R=	0.65	0.81
	WS-08	0.015	ha	R=	0.50	0.62
	WS-09	0.037	ha	R=	0.48	0.59
	WS-10	0.017	ha	R=	0.22	0.28
	Total Uncontrolled =	0.090	ha	ΣR=	0.47	0.59

Post-development Stormwater Management (100-Yr)

$I_{100} = 1735.688 / (T_d + 6.014)^{0.820}$

A = 1735.688

B = 0.820

C = 6.014

Time (min)	Intensity (mm/hr)	Controlled Runoff (L/s)	Storage Volume (m ³)	Controlled Release Rate (L/s)	Uncontrolled Runoff (L/s)	Total Release Rate (L/s)
10	178.56	190.60	67.25	78.51	26.49	105.00
15	142.89	152.53	66.61	78.51	21.20	99.71
20	119.95	128.04	59.43	78.51	17.79	96.31
25	103.85	110.85	48.51	78.51	15.41	93.92
30	91.87	98.06	35.19	78.51	13.63	92.14
35	82.58	88.15	20.23	78.51	12.25	90.76
40	75.15	80.21	4.08	78.51	11.15	89.66
45	69.05	73.71	0.00	78.51	10.24	88.75
50	63.95	68.27	0.00	78.51	9.49	88.00
55	59.62	63.64	0.00	78.51	8.85	87.36
60	55.89	59.66	0.00	78.51	8.29	86.80
65	52.65	56.20	0.00	78.51	7.81	86.32
70	49.79	53.15	0.00	78.51	7.39	85.90
75	47.26	50.44	0.00	78.51	7.01	85.52
80	44.99	48.02	0.00	78.51	6.67	85.19
85	42.95	45.85	0.00	78.51	6.37	84.88
90	41.11	43.88	0.00	78.51	6.10	84.61
95	39.43	42.09	0.00	78.51	5.85	84.36
100	37.90	40.46	0.00	78.51	5.62	84.13
105	36.50	38.96	0.00	78.51	5.41	83.93
110	35.20	37.58	0.00	78.51	5.22	83.73
115	34.01	36.30	0.00	78.51	5.04	83.56
120	32.89	35.11	0.00	78.51	4.88	83.39

On-site stormwater detention

Storage required = 67.25 m³
Surface storage provided = 74.97 m³ (See Dwg C601)



LRL File No. 230273
Project: Proposed Development-Halo Car Wash
Location: 3095 Palladium Drive, Kanata
Date: February 13, 2024
Designed: M. Longtin
Checked: M. Basnet
Drawing Ref.: C701, C702

**Stormwater Management
Design Sheet**

STORM - 5 YEAR

Runoff Equation

$Q = 2.78CIA$ (L/s)
 C = Runoff coefficient
 $I = \text{Rainfall intensity (mm/hr)} = A / (T_d + C)^B$
 A = Area (ha)
 $T_c = \text{Time of concentration (min)}$

Pre-development Catchment within Development Area

		Total Area =	0.536	ha	ΣR=	0.24
Uncontrolled	EWS-01		0.536	ha	R=	0.24
	Total Uncontrolled =		0.536	ha	ΣR=	0.24

Allowable Release Rate = 105.00 L/s (As determined by Robinsons Consultants Inc.)

Post-development Stormwater Management

					ΣR _{2&5}	ΣR ₁₀₀	
		Total Site Area =	0.536	ha	ΣR=	0.65	0.82
Controlled	WS-01	0.095	ha	R=	0.81	1.00	
	WS-02	0.062	ha	R=	0.90	1.00	
	WS-03	0.042	ha	R=	0.68	0.85	
	WS-04	0.172	ha	R=	0.54	0.68	
	WS-05	0.064	ha	R=	0.79	0.99	
	WS-06	0.012	ha	R=	0.20	0.25	
		Total Controlled =	0.446	ha	ΣR=	0.69	0.86
Uncontrolled	WS-07	0.022	ha	R=	0.65	0.81	
	WS-08	0.015	ha	R=	0.50	0.62	
	WS-09	0.037	ha	R=	0.48	0.59	
	WS-10	0.017	ha	R=	0.22	0.28	
		Total Uncontrolled =	0.090	ha	ΣR=	0.47	0.59

Post-development Stormwater Management (5-Yr)

$I_5 = 998.071 / (T_d + 6.053)^{0.814}$
A = 998.071
B = 0.814
C = 6.053

Time (min)	Intensity (mm/hr)	Controlled Runoff (L/s)	Storage Volume (m ³)	Controlled Release Rate (L/s)	Uncontrolled Runoff (L/s)	Total Release Rate (L/s)
10	104.19	88.97	6.28	78.51	12.37	90.88
15	83.56	71.35	0.00	78.51	9.92	88.43
20	70.25	59.99	0.00	78.51	8.34	86.85
25	60.90	52.00	0.00	78.51	7.23	85.74
30	53.93	46.05	0.00	78.51	6.40	84.91
35	48.52	41.43	0.00	78.51	5.76	84.27
40	44.18	37.73	0.00	78.51	5.24	83.75
45	40.63	34.69	0.00	78.51	4.82	83.33
50	37.65	32.15	0.00	78.51	4.47	82.98
55	35.12	29.99	0.00	78.51	4.17	82.68
60	32.94	28.13	0.00	78.51	3.91	82.42
65	31.04	26.51	0.00	78.51	3.68	82.20
70	29.37	25.08	0.00	78.51	3.49	82.00
75	27.89	23.81	0.00	78.51	3.31	81.82
80	26.56	22.68	0.00	78.51	3.15	81.66
85	25.37	21.66	0.00	78.51	3.01	81.52
90	24.29	20.74	0.00	78.51	2.88	81.39
95	23.31	19.90	0.00	78.51	2.77	81.28
100	22.41	19.13	0.00	78.51	2.66	81.17
105	21.58	18.43	0.00	78.51	2.56	81.07
110	20.82	17.78	0.00	78.51	2.47	80.98
115	20.12	17.18	0.00	78.51	2.39	80.90
120	19.47	16.62	0.00	78.51	2.31	80.82

On-site stormwater detention

Storage required = 6.28 m³



LRL File No. 230273
 Project: Proposed Development-Halo Car Wash
 Location: 3095 Palladium Drive, Kanata
 Date: February 13, 2024
 Designed: M. Longtin
 Checked: M. Basnet
 Drawing Ref.: C701, C702

Stormwater Management
 Design Sheet

STORM - 2 YEAR

Runoff Equation

$Q = 2.78CIA$ (L/s)
 C = Runoff coefficient
 $I = \text{Rainfall intensity (mm/hr)} = A / (T_d + C)^0.5$
 A = Area (ha)
 $T_c = \text{Time of concentration (min)}$

Pre-development Catchment within Development Area

Uncontrolled	Total Area =	0.536	ha	$\Sigma R =$	0.24
	EWS-01	0.536	ha	R =	0.24
	Total Uncontrolled =	0.536	ha	$\Sigma R =$	0.24

Allowable Release Rate = 105.00 L/s (As determined by Robinsons Consultants Inc.)

Post-development Stormwater Management

				ΣR_{25s}	ΣR_{100}
Controlled	Total Site Area =	0.536	ha	$\Sigma R =$	0.65
	WS-01	0.095	ha	R =	0.81
	WS-02	0.062	ha	R =	0.90
	WS-03	0.042	ha	R =	0.68
	WS-04	0.172	ha	R =	0.54
	WS-05	0.064	ha	R =	0.79
	WS-06	0.012	ha	R =	0.20
	Total Controlled =	0.446	ha	$\Sigma R =$	0.69
Uncontrolled	WS-07	0.022	ha	R =	0.65
	WS-08	0.015	ha	R =	0.50
	WS-09	0.037	ha	R =	0.48
	WS-10	0.017	ha	R =	0.22
	Total Uncontrolled =	0.090	ha	$\Sigma R =$	0.47

Post-development Stormwater Management (2-Yr)

$I_2 = 732.951 / (T_d + 6.199)^{0.810}$

A = 732.951

B = 0.810

C = 6.199

Time (min)	Intensity (mm/hr)	Controlled Runoff (L/s)	Storage Volume (m ³)	*Controlled Release Rate (L/s)	Uncontrolled Runoff (L/s)	Total Release Rate (L/s)
10	76.81	65.59	15.80	39.26	9.12	48.37
15	61.77	52.75	12.14	39.26	7.33	46.59
20	52.03	44.43	6.21	39.26	6.17	45.43
25	45.17	38.57	0.00	39.26	5.36	44.62
30	40.04	34.19	0.00	39.26	4.75	44.01
35	36.06	30.79	0.00	39.26	4.28	43.54
40	32.86	28.06	0.00	39.26	3.90	43.16
45	30.24	25.82	0.00	39.26	3.59	42.84
50	28.04	23.95	0.00	39.26	3.33	42.58
55	26.17	22.35	0.00	39.26	3.11	42.36
60	24.56	20.97	0.00	39.26	2.91	42.17
65	23.15	19.77	0.00	39.26	2.75	42.00
70	21.91	18.71	0.00	39.26	2.60	41.86
75	20.81	17.77	0.00	39.26	2.47	41.73
80	19.83	16.93	0.00	39.26	2.35	41.61
85	18.94	16.18	0.00	39.26	2.25	41.50
90	18.14	15.49	0.00	39.26	2.15	41.41
95	17.41	14.87	0.00	39.26	2.07	41.32
100	16.75	14.30	0.00	39.26	1.99	41.24
105	16.13	13.78	0.00	39.26	1.91	41.17
110	15.57	13.29	0.00	39.26	1.85	41.10
115	15.05	12.85	0.00	39.26	1.79	41.04
120	14.56	12.43	0.00	39.26	1.73	40.98

*Average release rate taken as 50% of max. allowable controlled release rate for an underground storage calculation

On-site stormwater detention

Storage required = 15.80 m³
 Underground storage provided = 21.10 m³ (oversized pipe storage & CB/CBMH storage)

Pipe Storage

Length (m)	dia. (m)	Storage (m ³)
39.30	0.250	1.93
23.30	0.375	2.57
29.00	0.450	4.61
32.50	0.250	1.60
7.70	0.450	1.23
Total		11.94

CB/CBMH Storage

CB/CBMH	Depth (m)	dia. (m)	Storage (m ³)
CB01	1.36	0.6*0.6	0.49
CBMH02	1.59	1.20	1.80
CBMH03	1.72	1.20	1.95
CB04	1.68	0.6*0.6	0.60
CBMH05	1.87	1.20	2.12
CBMH06	1.95	1.20	2.21
Total			9.16

LRL Associates Ltd.
Storm Design Sheet



LRL File No. 230273
Project: Proposed Development-Halo Car Wash
Location: 3095 Palladium Drive, Kanata
Date: February 15, 2024
Designed: M. Longtin
Checked: M. Basnet
Drawing Reference: C702, C401

Storm Design Parameters

<u>Rational Method</u>	<u>Runoff Coefficient (C)</u>	<u>City of Ottawa IDF curve equation</u>
Q = 2.78CIA	Grass 0.20	(5 year event, intensity in mm/hr)
Q = Peak flow (L/s)	Gravel 0.80	$I_5 = 998.071 / (Td + 6.053)^{0.814}$
A = Drainage area (ha)	Asphalt / rooftop 0.90	Min. velocity = 0.80 m/s
C = Runoff coefficient		Manning's "n" = 0.013
I = Rainfall intensity (mm/hr)		

LOCATION			AREA (ha)			FLOW						STORM SEWER							
WATERSHED / STREET	From MH	To MH	C = 0.20	C = 0.80	C = 0.90	Indiv. 2.78AC	Accum. 2.78AC	Time of Conc. (min.)	Rainfall Intensity (mm/hr)	Peak Flow Q (L/s)	Controlled Flow Q (L/s)	Pipe Diameter (mm)	Type	Slope (%)	Length (m)	Capacity Full (L/s)	Velocity Full (m/s)	Time of Flow (min.)	Ratio (Q/Q _{FULL})
WS-01	CB01	CBMH02	0.013	0.000	0.082	0.21	0.21	10.00	104.19	22.04		250	PVC	0.50%	39.3	42.0	0.86	0.76	0.52
WS-02	CBMH02	CBMH03	0.000	0.000	0.062	0.16	0.37	10.76	100.32	36.81		375	PVC	0.30%	23.3	96.0	0.87	0.45	0.38
WS-03	CBMH03	CBMH05	0.013	0.000	0.028	0.08	0.45	11.21	98.20	43.71		450	PVC	0.30%	29.0	156.2	0.98	0.49	0.28
WS-04	CB04	CBMH05	0.088	0.000	0.085	0.26	0.26	10.00	104.19	27.16		250	PVC	0.50%	32.5	42.0	0.86	0.63	0.65
WS-05	CBMH05	CBMH06	0.010	0.000	0.055	0.14	0.85	11.70	95.98	81.35		450	PVC	0.30%	8.8	156.2	0.98	0.15	0.52
WS-06	CBMH06	EX. Sewer	0.012	0.000	0.000	0.01	0.85	11.85	95.33	81.40	78.51	375	PVC	0.26%	15.4	89.4	0.81	0.32	0.88

CSO/STORMWATER MANAGEMENT



HYDROVEX[®] VHV / SVHV
Vertical Vortex Flow Regulator

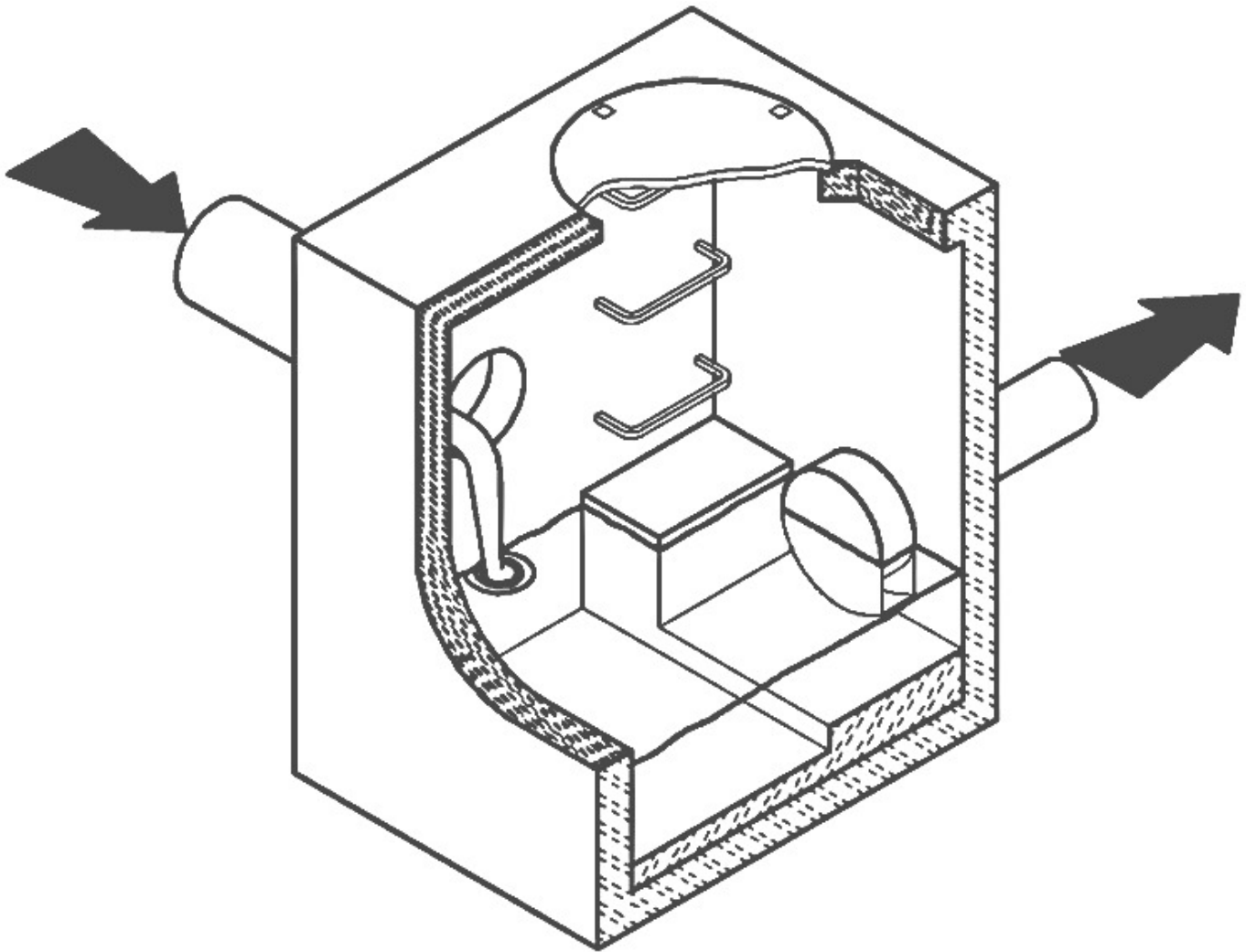

JOHN MEUNIER

HYDROVEX® VHV / SVHV VERTICAL VORTEX FLOW REGULATOR

APPLICATIONS

One of the major problems of urban wet weather flow management is the runoff generated after a heavy rainfall. During a storm, uncontrolled flows may overload the drainage system and cause flooding. Due to increased velocities, sewer pipe wear is increased dramatically and results in network deterioration. In a combined sewer system, the wastewater treatment plant may also experience significant increases in flows during storms, thereby losing its treatment efficiency.

A simple means of controlling excessive water runoff is by controlling excessive flows at their origin (manholes). **John Meunier Inc.** manufactures the **HYDROVEX® VHV / SVHV** line of vortex flow regulators to control stormwater flows in sewer networks, as well as manholes.

The vortex flow regulator design is based on the fluid mechanics principle of the forced vortex. This grants flow regulation without any moving parts, thus reducing maintenance. The operation of the regulator, depending on the upstream head and discharge, switches between orifice flow (gravity flow) and vortex flow. Although the concept is quite simple, over 12 years of research have been carried out in order to get a high performance.

The **HYDROVEX® VHV / SVHV** Vertical Vortex Flow Regulators (refer to **Figure 1**) are manufactured entirely of stainless steel, and consist of a hollow body (1) (in which flow control takes place) and an outlet orifice (7). Two rubber "O" rings (3) seal and retain the unit inside the outlet pipe. Two stainless steel retaining rings (4) are welded on the outlet sleeve to ensure that there is no shifting of the "O" rings during installation and use.

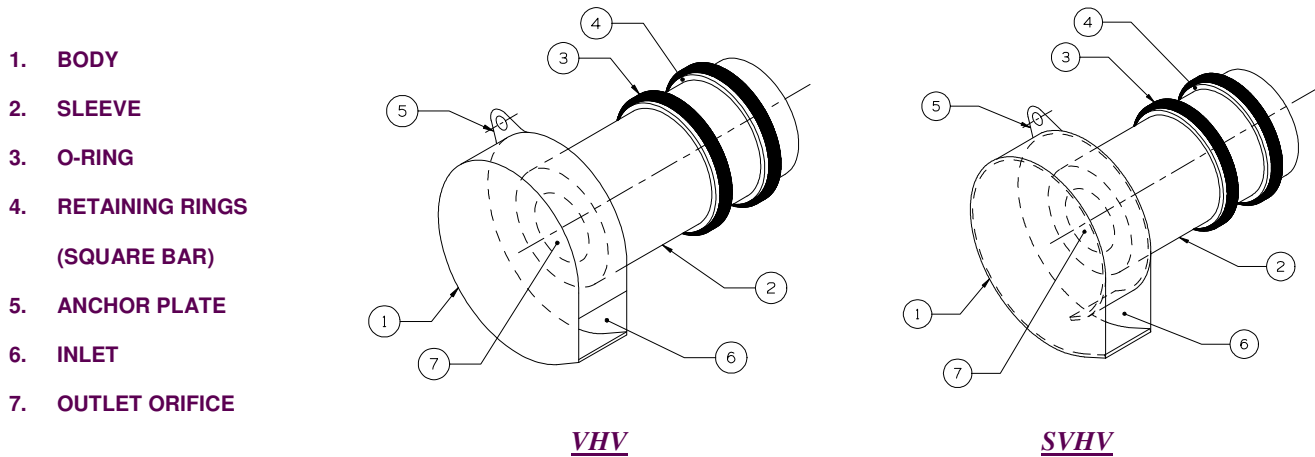

FIGURE 1: HYDROVEX® VHV-SVHV VERTICAL VORTEX FLOW REGULATORS

ADVANTAGES

- The **HYDROVEX® VHV / SVHV** line of flow regulators are manufactured entirely of stainless steel, making them durable and corrosion resistant.
- Having no moving parts, they require minimal maintenance.
- The geometry of the **HYDROVEX® VHV / SVHV** flow regulators allows a control equal to an orifice plate, having a cross section area 4 to 6 times smaller. This decreases the chance of blockage of the regulator, due to sediments and debris found in stormwater flows. **Figure 2** illustrates the comparison between a regulator model 100 SVHV-2 and an equivalent orifice plate. One can see that for the same height of water, the regulator controls a flow approximately four times smaller than an equivalent orifice plate.
- Installation of the **HYDROVEX® VHV / SVHV** flow regulators is quick and straightforward and is performed after all civil works are completed.
- Installation requires no special tools or equipment and may be carried out by any contractor.
- Installation may be carried out in existing structures.

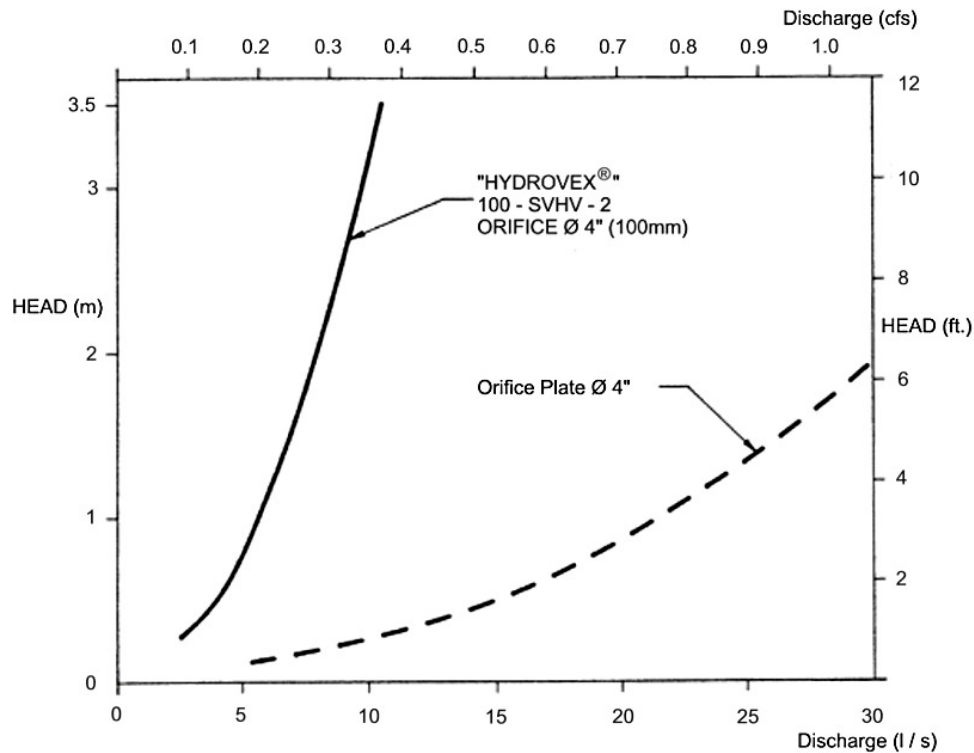

FIGURE 2: DISCHARGE CURVE SHOWING A HYDROVEX® FLOW REGULATOR VS AN ORIFICE PLATE

SELECTION

Selection of a **VHV** or **SVHV** regulator can be easily made using the selection charts found at the back of this brochure (see **Figure 3**). These charts are a graphical representation of the maximum upstream water pressure (head) and the maximum discharge at the manhole outlet. The maximum design head is the difference between the maximum upstream water level and the invert of the outlet pipe. All selections should be verified by John Meunier Inc. personnel prior to fabrication.

Example:

- ✓ Maximum design head 2m (6.56 ft.)
- ✓ Maximum discharge 6 L/s (0.2 cfs)
- ✓ Using **Figure 3** - VHV model required is a **75 VHV-1**

INSTALLATION REQUIREMENTS

All **HYDROVEX®** **VHV** / **SVHV** flow regulators can be installed in circular or square manholes. **Figure 4** gives the various minimum dimensions required for a given regulator. *It is imperative to respect the minimum clearances shown to ensure easy installation and proper functioning of the regulator.*

SPECIFICATIONS

In order to specify a **HYDROVEX**[®] regulator, the following parameters must be defined:

- The model number (ex: 75-VHV-1)
- The diameter and type of outlet pipe (ex: 6" diam. SDR 35)
- The desired discharge (ex: 6 l/s or 0.21 CFS)
- The upstream head (ex: 2 m or 6.56 ft.) *
- The manhole diameter (ex: 36" diam.)
- The minimum clearance "H" (ex: 10 inches)
- The material type (ex: 304 s/s, 11 Ga. standard)

* *Upstream head is defined as the difference in elevation between the maximum upstream water level and the invert of the outlet pipe where the **HYDROVEX**[®] flow regulator is to be installed.*

PLEASE NOTE THAT WHEN REQUESTING A PROPOSAL, WE SIMPLY REQUIRE THAT YOU PROVIDE US WITH THE FOLLOWING:

- *project design flow rate*
- *pressure head*
- *chamber's outlet pipe diameter and type*



Typical VHV model in factory

OPTIONS



FV – SVHV (mounted on sliding plate)



VHV-1-O (standard model with odour control inlet)

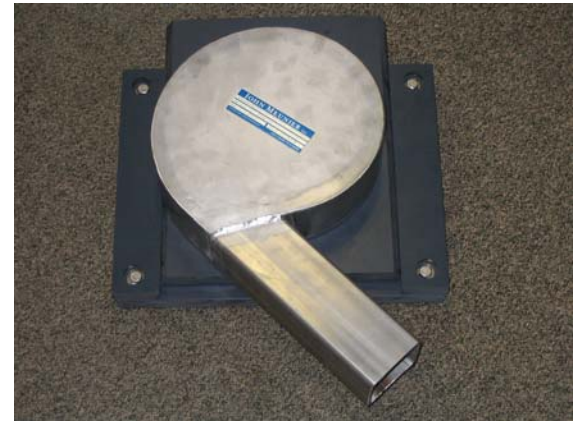

FV – VHV-O (mounted on sliding plate with odour control inlet)



VHV with Gooseneck assembly in existing chamber without minimum release at the bottom



VHV with air vent for minimal slopes



VHV Vertical Vortex Flow Regulator

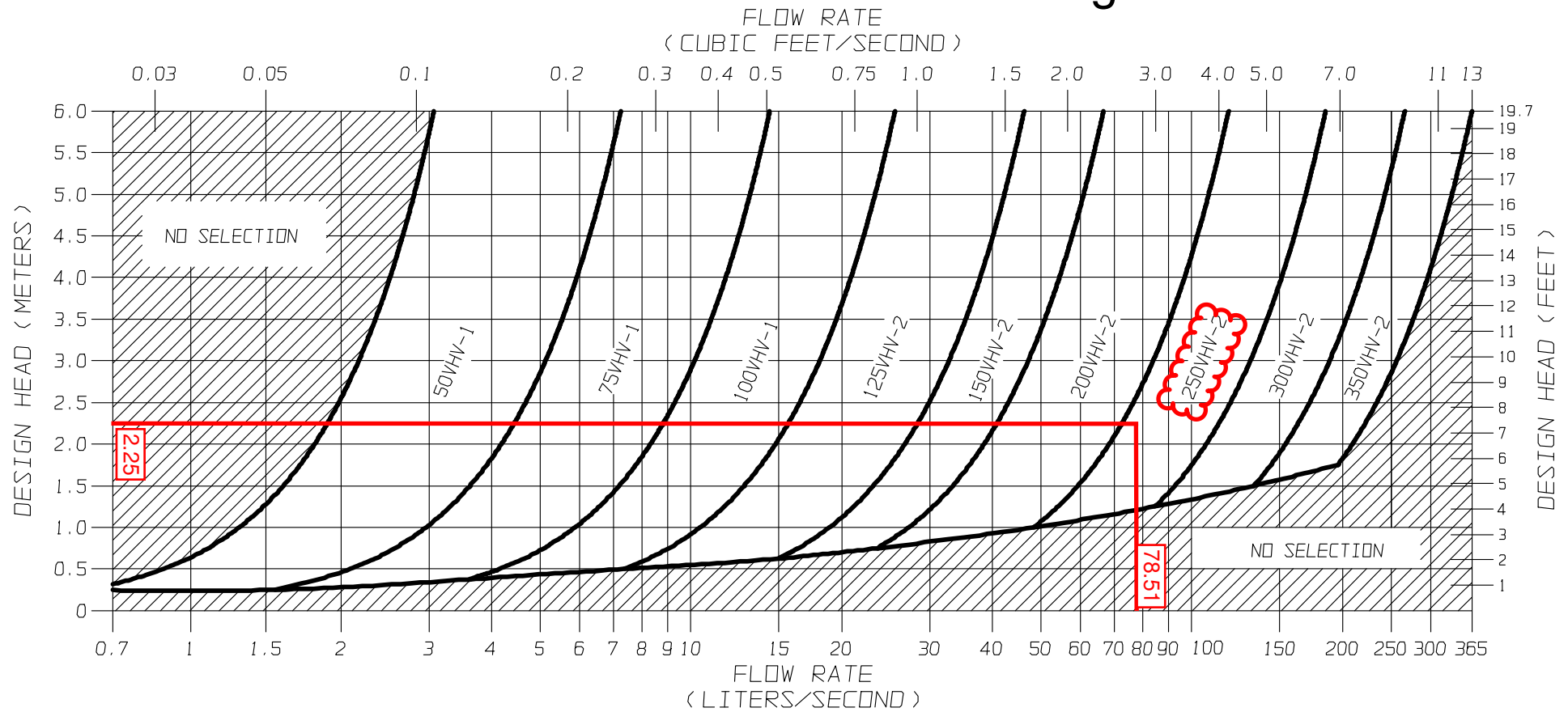
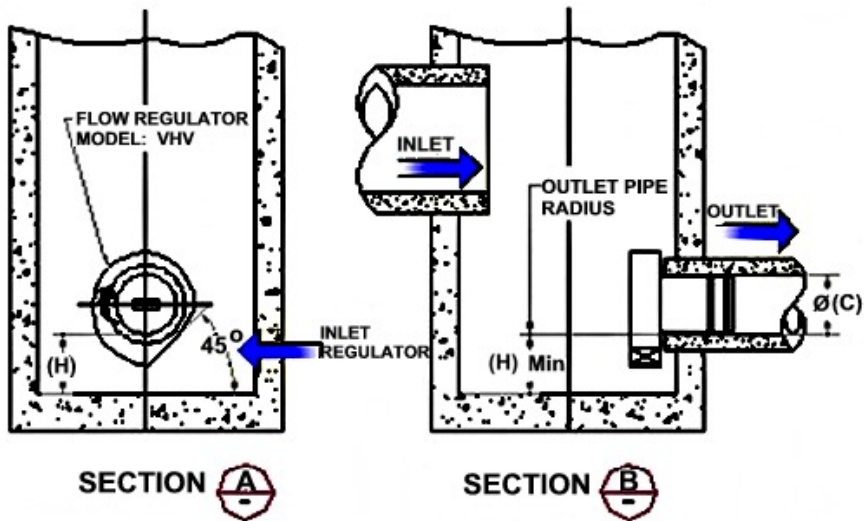
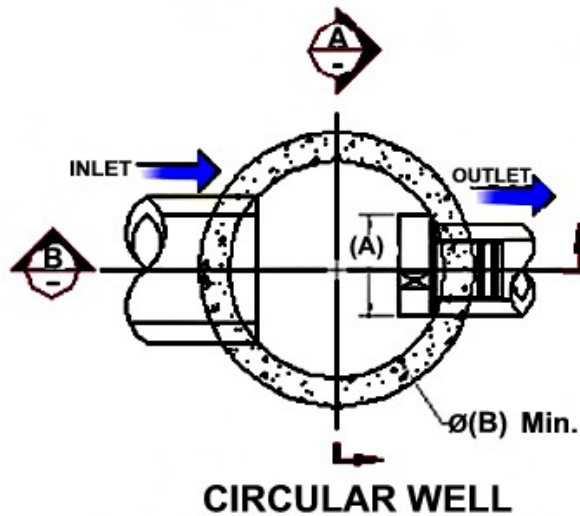

FIGURE 3 - VHV

JOHN MEUNIER

**FLOW REGULATOR TYPICAL INSTALLATION IN CIRCULAR MANHOLE
FIGURE 4 (MODEL VHV)**

Model Number	Regulator Diameter		Minimum Manhole Diameter		Minimum Outlet Pipe Diameter		Minimum Clearance	
	A (mm)	A (in.)	B (mm)	B (in.)	C (mm)	C (in.)	H (mm)	H (in.)
50VHV-1	150	6	600	24	150	6	150	6
75VHV-1	250	10	600	24	150	6	150	6
100VHV-1	325	13	900	36	150	6	200	8
125VHV-2	275	11	900	36	150	6	200	8
150VHV-2	350	14	900	36	150	6	225	9
200VHV-2	450	18	1200	48	200	8	300	12
250VHV-2	575	23	1200	48	250	10	350	14
300VHV-2	675	27	1600	64	250	10	400	16
350VHV-2	800	32	1800	72	300	12	500	20



INSTALLATION

The installation of a **HYDROVEX**[®] regulator may be undertaken once the manhole and piping is in place. Installation consists of simply fitting the regulator into the outlet pipe of the manhole. **John Meunier Inc.** recommends the use of a lubricant on the outlet pipe, in order to facilitate the insertion and orientation of the flow controller.

MAINTENANCE

HYDROVEX[®] regulators are manufactured in such a way as to be maintenance free; however, a periodic inspection (every 3-6 months) is suggested in order to ensure that neither the inlet nor the outlet has become blocked with debris. The manhole should undergo periodically, particularly after major storms, inspection and cleaning as established by the municipality

GUARANTY

The **HYDROVEX**[®] line of **VHV / SVHV** regulators are guaranteed against both design and manufacturing defects for a period of 5 years. Should a unit be defective, **John Meunier Inc.** is solely responsible for either modification or replacement of the unit.

John Meunier Inc.

ISO 9001 : 2008

Head Office

4105 Sartelon

Saint-Laurent (Quebec) Canada H4S 2B3

Tel.: 514-334-7230 www.johnmeunier.com

Fax: 514-334-5070 cs@johnmeunier.com

Ontario Office

2000 Argentia Road, Plaza 4, Unit 430

Mississauga (Ontario) Canada L5N 1W1

Tel.: 905-286-4846 www.johnmeunier.com

Fax: 905-286-0488 ontario@johnmeunier.com

USA Office

2209 Menlo Avenue

Glenside, PA USA 19038

Tel.: 412-417-6614 www.johnmeunier.com

Fax: 215-885-4741 astele@johnmeunier.com

APPENDIX E
Civil Engineering Drawings

PROPOSED DEVELOPMENT HALO CAR WASH 3095 PALLADIUM DRIVE KANATA, ON

REVISION 04

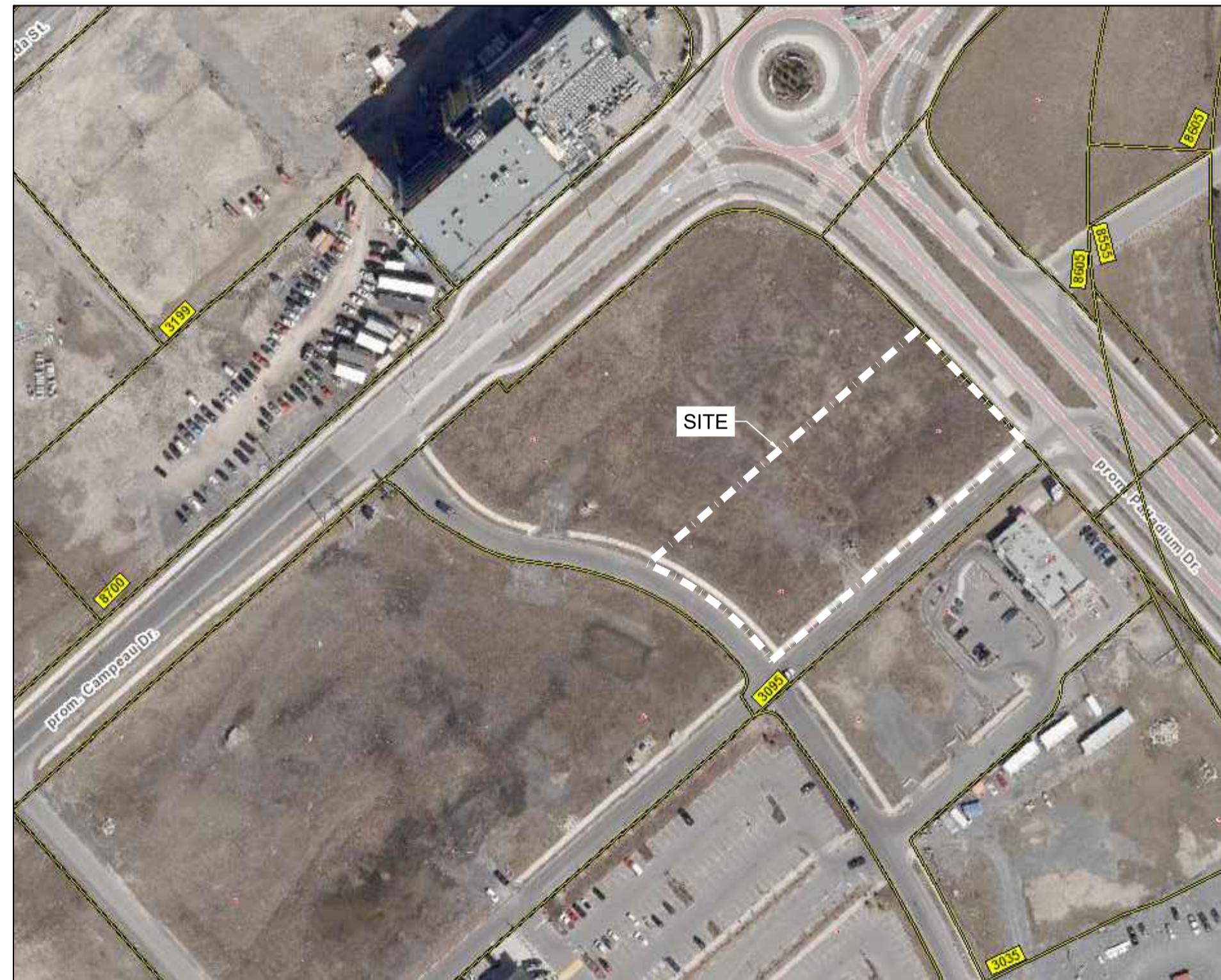

KEY PLAN (N.T.S.)

DRAWING INDEX	
TITLE PAGE	
GENERAL NOTES	C001
SEDIMENT AND EROSION CONTROL PLAN	C101
SITE DEVELOPMENT PLAN	C201
GRADING AND DRAINAGE PLAN	C301
SERVICING PLAN	C401
SERVICING PLAN - RECLAIM TANKS	C402
STORMWATER MANAGEMENT PLAN	C601
PRE-DEVELOPMENT WATERSHED PLAN	C701
POST-DEVELOPMENT WATERSHED PLAN	C702
CONSTRUCTION DETAIL PLAN	C901



LRL

ENGINEERING | INGÉNIERIE

5430 Canotek Road | Ottawa, ON, K1J 9G2
www.lrl.ca | (613) 842-3434

PROPOSED DEVELOPMENT - HALO CAR WASH
3095 PALLADIUM DRIVE, KANATA (ON)
REV.04 - RE-ISSUED FOR APPROVAL - MARCH 4th, 2024
LRL PROJECT no: 230273



NOT AUTHENTIC UNLESS SIGNED AND DATED

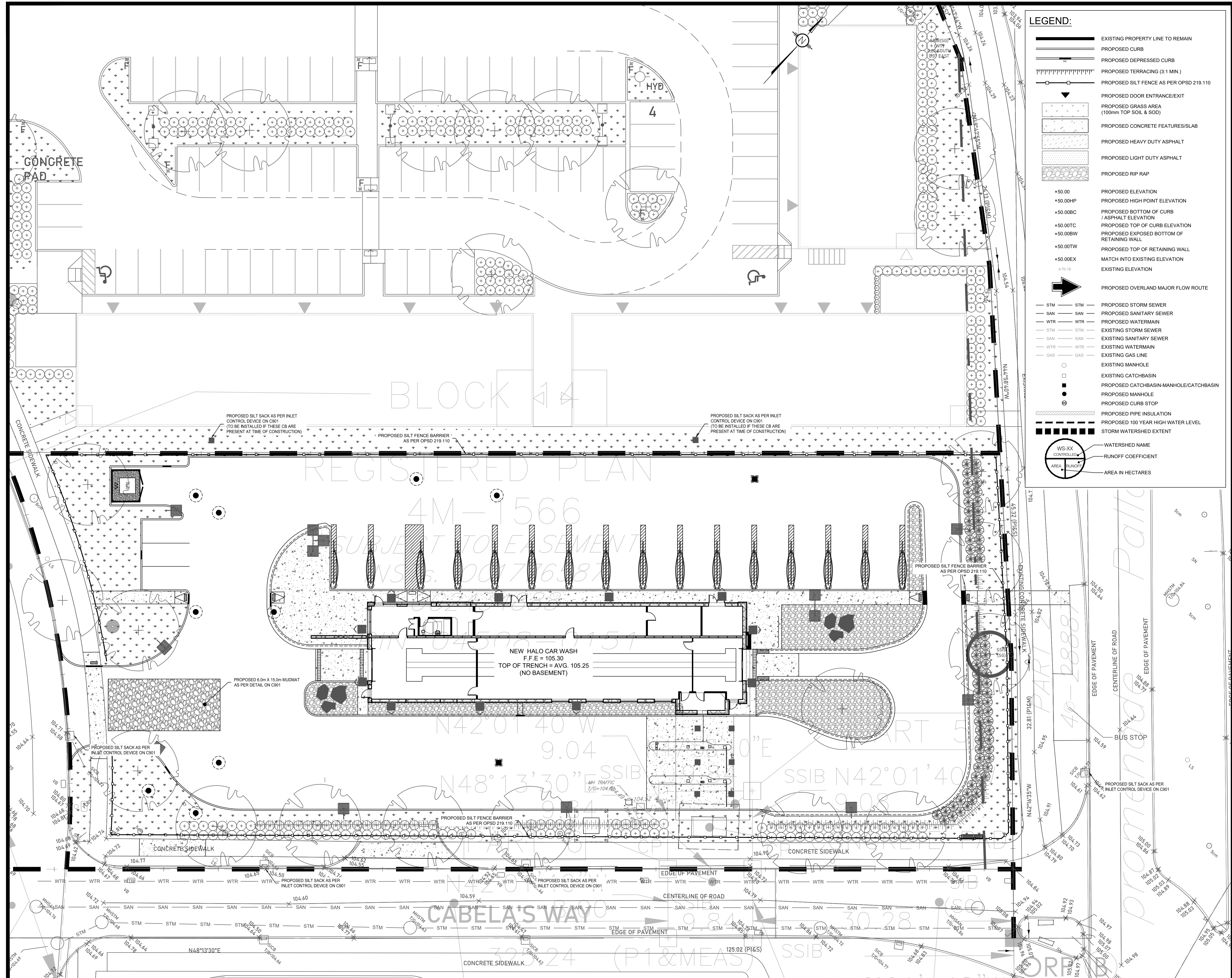

LEGEND:

- EXISTING PROPERTY LINE TO REMAIN
- PROPOSED CURB
- PROPOSED DEPRESSED CURB
- PROPOSED TERRACING (3:1 MIN.)
- PROPOSED SILT FENCE AS PER OPSD 219.110
- PROPOSED DOOR ENTRANCE/EXIT
- PROPOSED GRASS AREA (100mm TOP SOIL & SOD)
- PROPOSED CONCRETE FEATURES/SLAB
- PROPOSED HEAVY DUTY ASPHALT
- PROPOSED LIGHT DUTY ASPHALT
- PROPOSED RIP RAP
- PROPOSED ELEVATION
- PROPOSED HIGH POINT ELEVATION
- PROPOSED BOTTOM OF CURB / ASPHALT ELEVATION
- PROPOSED TOP OF CURB ELEVATION
- PROPOSED EXPOSED BOTTOM OF RETAINING WALL
- PROPOSED TOP OF RETAINING WALL
- MATCH INTO EXISTING ELEVATION
- EXISTING ELEVATION
- PROPOSED OVERLAND MAJOR FLOW ROUTE
- PROPOSED STORM SEWER
- PROPOSED SANITARY SEWER
- PROPOSED WATERMAIN
- EXISTING STORM SEWER
- EXISTING SANITARY SEWER
- EXISTING WATERMAIN
- EXISTING GAS LINE
- EXISTING MANHOLE
- EXISTING CATCHBASIN
- PROPOSED CATCHBASIN-MANHOLE/CATCHBASIN
- PROPOSED MANHOLE
- PROPOSED CURB STOP
- PROPOSED PIPE INSULATION
- PROPOSED 100 YEAR HIGH WATER LEVEL
- STORM WATERSHED EXTENT
- WATERSHED NAME
- RUNOFF COEFFICIENT
- AREA IN HECTARES

USE AND INTERPRETATION OF DRAWINGS

GENERAL CONDITIONS OF THE CONTRACT FOR CONSTRUCTION ARE PART OF THE CONTRACT DOCUMENTS AND DESCRIBE USE AND INTENT OF THE DRAWING. THE CONTRACT DOCUMENTS INCLUDE NOT ONLY THE DRAWINGS, BUT ALSO THE OWNER-CONTRACTOR AGREEMENTS, CONDITIONS OF THE CONTRACT, THE SPECIFICATIONS, ADDENDA, AND MODIFICATIONS ISSUED AFTER EXECUTION OF THE CONTRACT. THESE CONTRACT DOCUMENTS ARE COMPLEMENTARY, AND WHAT IS REQUIRED BY ANY ONE SHALL BE BINDING AS REQUIRED BY ALL. WORK NOT COMPLETELY DELINEATED HEREON SHALL BE CONSTRUCTED OF THE SAME MATERIALS AND DETAILED SIMILARLY AS WORK SHOWN MORE COMPLETELY ELSEWHERE IN THE CONTRACT DOCUMENTS.

BY USE OF THE DRAWINGS FOR CONSTRUCTION OF THE PROJECT, THE OWNER CONFIRMS THAT HE HAS REVIEWED AND APPROVED THE DRAWINGS. THE CONTRACTOR CONFIRMS THAT HE HAS VISITED THE SITE, FAMILIARIZED HIMSELF WITH THE LOCAL CONDITIONS, VERIFIED FIELD DIMENSIONS AND CORRELATED HIS OBSERVATIONS WITH THE REQUIREMENTS OF THE CONTRACT DOCUMENTS.

AS INSTRUMENTS OF SERVICE, ALL DRAWINGS, SPECIFICATIONS, CAD FILES OR OTHER ELECTRONIC MEDIA AND COPIES THEREOF FURNISHED BY THE ENGINEER ARE HIS PROPERTY. THEY ARE TO BE USED ONLY FOR THIS PROJECT AND ARE NOT TO BE USED ON ANY OTHER PROJECT, INCLUDING REPEATS OF THE PROJECT. CHANGES TO THE DRAWINGS MAY ONLY BE MADE BY THE ENGINEER.

UNLESS THE REVISION TITLE IS "ISSUED FOR CONSTRUCTION", THESE DRAWINGS SHALL BE CONSIDERED PRELIMINARY AND SHALL NOT BE USED AS A CONSTRUCTION DOCUMENT.

THESE DRAWINGS ILLUSTRATE THE WORK TO BE DONE. THE ENGINEER IS NOT RESPONSIBLE FOR THE MEANS, METHODS, TECHNIQUES, SEQUENCES, AND PROCEDURES USED TO DO THE WORK, OR THE SAFETY ASPECTS OF CONSTRUCTION, AND NOTHING ON THESE DRAWINGS EXPRESSED OR IMPLIED CHANGES THIS CONDITION. CONTRACTOR SHALL DETERMINE ALL CONDITIONS AT THE SITE AND SHALL BE RESPONSIBLE FOR KNOWING HOW THEY AFFECT THE WORK. SUBMITTAL OF A BID TO PERFORM THIS WORK IS ACKNOWLEDGEMENT OF THE RESPONSIBILITIES, AND THAT THEY HAVE BEEN FULLY CONSIDERED IN PLANNING OF THE WORK, AND THE BID PRICE. NO CLAIMS FOR EXTRA CHARGES DUE TO THESE CONDITIONS WILL BE FORTHCOMING.

UNAUTHORIZED CHANGES:

IN THE EVENT THE CLIENT, THE CLIENT'S CONTRACTORS OR SUBCONTRACTORS, OR ANYONE FOR WHOM THE CLIENT IS LEGALLY LIABLE MAKES OR PERMITS TO BE MADE ANY CHANGES TO ANY REPORTS, PLANS, SPECIFICATIONS OR OTHER CONSTRUCTION DOCUMENTS PREPARED BY LRL ASSOCIATES LTD. (LRL) WITHOUT OBTAINING LRL'S PRIOR WRITTEN CONSENT, THE CLIENT SHALL ASSUME FULL RESPONSIBILITY FOR THE RESULTS OF SUCH CHANGES. THEREFORE THE CLIENT AGREES TO WAIVE ANY CLAIM AGAINST LRL AND TO RELEASE LRL FROM ANY LIABILITY ARISING DIRECTLY OR INDIRECTLY FROM SUCH UNAUTHORIZED CHANGES.

IN ADDITION, THE CLIENT AGREES, TO THE FULLEST EXTENT PERMITTED BY LAW, TO INDEMNIFY AND HOLD HARMLESS LRL FROM ANY DAMAGES, LIABILITIES OR COST, INCLUDING REASONABLE ATTORNEY'S FEES AND COST OF DEFENSE, ARISING FROM SUCH CHANGES.

THE ENGINEER WAIVES ANY AND ALL RESPONSIBILITY AND LIABILITY FOR PROBLEMS WHICH ARISE FROM FAILURE TO FOLLOW THESE PLANS, SPECIFICATIONS AND THE DESIGN INTENT THEY CONVEY, OR FOR PROBLEMS WHICH ARISE FROM OTHERS' FAILURE TO OBTAIN AND/OR FOLLOW THE ENGINEER'S GUIDANCE WITH RESPECT TO ANY ERRORS, OMISSIONS, INCONSISTENCIES, AMBIGUITIES OR CONFLICTS WHICH ARE ALLEGED.

CONTRACTOR TO VERIFY ALL DIMENSIONS AND NOTIFY THE ENGINEER OF ANY DISCREPANCIES BEFORE WORK COMMENCES. DO NOT SCALE DRAWINGS.

SCALE: 1:200

No.	REVISIONS	BY	DATE
04	RE-ISSUED FOR APPROVAL	M.L.	MAR 04 2024
03	RE-ISSUED FOR APPROVAL	M.L.	FEB 15 2024
02	RE-ISSUED FOR APPROVAL	M.L.	NOV 13 2023
01	ISSUED FOR APPROVAL	M.L.	JUNE 16 2023



NOT AUTHENTIC UNLESS SIGNED AND DATED



LRL
 ENGINEERING | INGÉNIERIE
 5430 Canotek Road | Ottawa, ON, K1J 9G2
 www.lrl.ca | (613) 842-3434

CLIENT
HALO CAR WASH

DESIGNED BY: M.L. DRAWN BY: M.L. APPROVED BY: M.B.

PROJECT
**PROPOSED DEVELOPMENT
 HALO CAR WASH
 3095 PALLADIUM DRIVE
 KANATA, ON**

DRAWING TITLE
**EROSION AND SEDIMENT
 CONTROL PLAN**

PROJECT NO.
230273

DATE
MAY 2023

C101

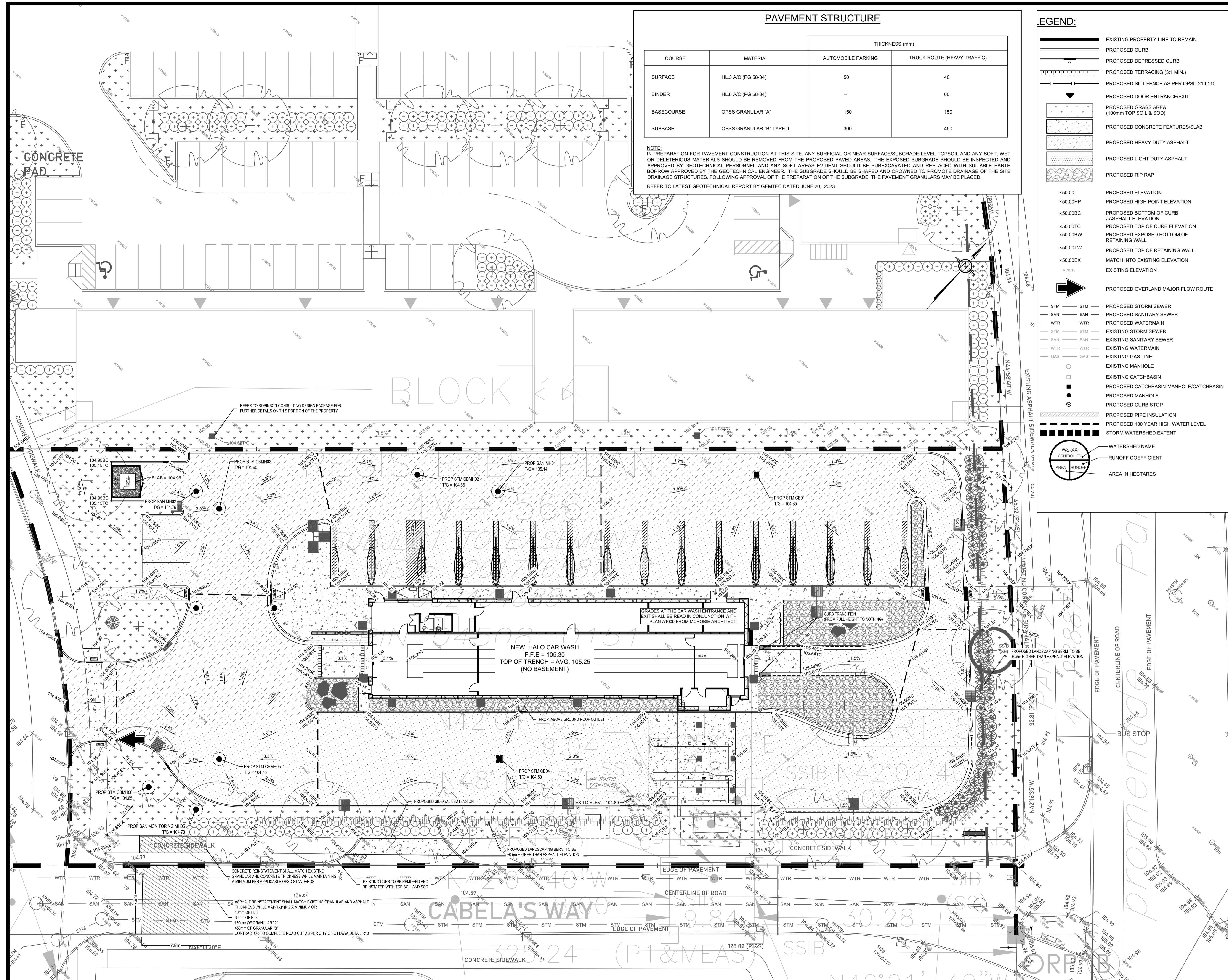

PAVEMENT STRUCTURE

COURSE	MATERIAL	THICKNESS (mm)	
		AUTOMOBILE PARKING	TRUCK ROUTE (HEAVY TRAFFIC)
SURFACE	HL.3 A/C (PG 58-34)	50	40
BINDER	HL.8 A/C (PG 58-34)	-	60
BASECOURSE	OPSS GRANULAR "A"	150	150
SUBBASE	OPSS GRANULAR "B" TYPE II	300	450

NOTE:
 IN PREPARATION FOR PAVEMENT CONSTRUCTION AT THIS SITE, ANY SURFICIAL OR NEAR SURFACE/SUBGRADE LEVEL TOPSOIL AND ANY SOFT, WET OR DELETERIOUS MATERIALS SHOULD BE REMOVED FROM THE PROPOSED PAVED AREAS. THE EXPOSED SUBGRADE SHOULD BE INSPECTED AND APPROVED BY GEOTECHNICAL PERSONNEL AND ANY SOFT AREAS EVIDENT SHOULD BE SUBCAVATED AND REPLACED WITH SUITABLE EARTH BORROW APPROVED BY THE GEOTECHNICAL ENGINEER. THE SUBGRADE SHOULD BE SHAPED AND CROWNED TO PROMOTE DRAINAGE OF THE SITE DRAINAGE STRUCTURES. FOLLOWING APPROVAL OF THE PREPARATION OF THE SUBGRADE, THE PAVEMENT GRANULARS MAY BE PLACED.
 REFER TO LATEST GEOTECHNICAL REPORT BY GEMTEC DATED JUNE 20, 2023.

EGEND:

- EXISTING PROPERTY LINE TO REMAIN
- PROPOSED CURB
- PROPOSED DEPRESSED CURB
- PROPOSED TERRACING (3:1 MIN.)
- PROPOSED SILT FENCE AS PER OPSD 219.110
- PROPOSED DOOR ENTRANCE/EXIT
- PROPOSED GRASS AREA (100mm TOP SOIL & SOD)
- PROPOSED CONCRETE FEATURES/SLAB
- PROPOSED HEAVY DUTY ASPHALT
- PROPOSED LIGHT DUTY ASPHALT
- PROPOSED RIP RAP
- PROPOSED ELEVATION
- PROPOSED HIGH POINT ELEVATION
- PROPOSED BOTTOM OF CURB / ASPHALT ELEVATION
- PROPOSED TOP OF CURB ELEVATION
- PROPOSED EXPOSED BOTTOM OF RETAINING WALL
- PROPOSED TOP OF RETAINING WALL
- MATCH INTO EXISTING ELEVATION
- EXISTING ELEVATION
- PROPOSED OVERLAND MAJOR FLOW ROUTE
- PROPOSED STORM SEWER
- PROPOSED SANITARY SEWER
- PROPOSED WATER MAIN
- EXISTING STORM SEWER
- EXISTING SANITARY SEWER
- EXISTING WATER MAIN
- EXISTING GAS LINE
- EXISTING MANHOLE
- EXISTING CATCHBASIN
- PROPOSED CATCHBASIN-MANHOLE/CATCHBASIN
- PROPOSED MANHOLE
- PROPOSED CURB STOP
- PROPOSED PIPE INSULATION
- PROPOSED 100 YEAR HIGH WATER LEVEL
- STORM WATERSHED EXTENT
- WATERSHED NAME
- RUNOFF COEFFICIENT
- AREA IN HECTARES

USE AND INTERPRETATION OF DRAWINGS

GENERAL CONDITIONS OF THE CONTRACT FOR CONSTRUCTION ARE PART OF THE CONTRACT DOCUMENTS AND DESCRIBE THE USE AND INTENT OF THE DRAWINGS. THE CONTRACTOR SHALL BE RESPONSIBLE FOR OBTAINING ALL NECESSARY PERMITS AND APPROVALS FROM THE LOCAL AUTHORITIES. THE CONTRACTOR SHALL BE RESPONSIBLE FOR OBTAINING ALL NECESSARY PERMITS AND APPROVALS FROM THE LOCAL AUTHORITIES. THE CONTRACTOR SHALL BE RESPONSIBLE FOR OBTAINING ALL NECESSARY PERMITS AND APPROVALS FROM THE LOCAL AUTHORITIES.

BY USE OF THE DRAWINGS FOR CONSTRUCTION OF THE PROJECT, THE OWNER CONFIRMS THAT HE HAS REVIEWED AND APPROVED THE DRAWINGS. THE CONTRACTOR CONFIRMS THAT HE HAS VISITED THE SITE, FAMILIARIZED HIMSELF WITH THE LOCAL CONDITIONS, VERIFIED FIELD DIMENSIONS AND CORRELATED HIS OBSERVATIONS WITH THE REQUIREMENTS OF THE CONTRACT DOCUMENTS.

AS INSTRUMENTS OF SERVICE, ALL DRAWINGS, SPECIFICATIONS, CAD FILES OR OTHER ELECTRONIC MEDIA AND COPIES THEREOF FURNISHED BY THE ENGINEER ARE HIS PROPERTY. THEY ARE TO BE USED ONLY FOR THIS PROJECT AND ARE NOT TO BE USED ON ANY OTHER PROJECT, INCLUDING REPEATS OF THE PROJECT. CHANGES TO THE DRAWINGS MAY ONLY BE MADE BY THE ENGINEER.

UNLESS THE REVISION TITLE IS ISSUED FOR CONSTRUCTION, THESE DRAWINGS SHALL BE CONSIDERED PRELIMINARY AND SHALL NOT BE USED AS A CONSTRUCTION DOCUMENT.

THESE DRAWINGS ILLUSTRATE THE WORK TO BE DONE. THE ENGINEER IS NOT RESPONSIBLE FOR THE MEANS, METHODS, TECHNIQUES, SEQUENCES, AND PROCEDURES USED TO DO THE WORK, OR THE SAFETY ASPECTS OF CONSTRUCTION, AND NOTHING ON THESE DRAWINGS EXPRESSED OR IMPLIED CHANGES THIS CONDITION. CONTRACTOR SHALL DETERMINE ALL CONDITIONS AT THE SITE AND SHALL BE RESPONSIBLE FOR KNOWING HOW THEY AFFECT THE WORK. SUBMITTALS OF BIDS TO PERFORM THIS WORK ARE ACKNOWLEDGMENT OF THE RESPONSIBILITIES, AND THAT THEY HAVE BEEN FULLY CONSIDERED IN PLANNING OF THE WORK AND THE BID PRICE. NO CLAIMS FOR EXTRA CHARGES DUE TO THESE CONDITIONS WILL BE FORTHCOMING.

UNAUTHORIZED CHANGES:

IN THE EVENT THE CLIENT, THE CLIENT'S CONTRACTORS OR SUBCONTRACTORS, OR ANYONE FOR WHOM THE CLIENT IS LEGALLY LIABLE MAKES OR PERMITS TO BE MADE ANY CHANGES TO ANY REPORTS, PLANS, SPECIFICATIONS OR OTHER CONSTRUCTION DOCUMENTS PREPARED BY LRL ASSOCIATES LTD. (LRL) WITHOUT OBTAINING LRL'S PRIOR WRITTEN CONSENT, THE CLIENT SHALL ASSUME FULL RESPONSIBILITY FOR THE RESULTS OF SUCH CHANGES. THEREFORE THE CLIENT AGREES TO WAIVE ANY CLAIM AGAINST LRL AND TO RELEASE LRL FROM ANY LIABILITY ARISING DIRECTLY OR INDIRECTLY FROM SUCH UNAUTHORIZED CHANGES.

IN ADDITION, THE CLIENT AGREES TO THE FULLEST EXTENT PERMITTED BY LAW, TO INDEMNIFY AND HOLD HARMLESS LRL FROM ANY DAMAGES, LIABILITIES OR COSTS, INCLUDING REASONABLE ATTORNEY'S FEES AND COSTS OF DEFENSE, ARISING FROM SUCH CHANGES.

IN ADDITION, THE CLIENT AGREES TO INCLUDE IN ANY CONTRACTS FOR CONSTRUCTION APPROPRIATE LANGUAGE THAT PROHIBITS THE CONTRACTOR OR ANY SUBCONTRACTORS OF ANY TIER FROM MAKING ANY CHANGES OR MODIFICATIONS TO LRL'S CONSTRUCTION DOCUMENTS WITHOUT THE PRIOR WRITTEN APPROVAL OF LRL AND THAT FURTHER REQUIRES THE CONTRACTOR TO INDEMNIFY BOTH LRL AND THE CLIENT FROM ANY LIABILITY OR COST ARISING FROM SUCH CHANGES MADE WITHOUT SUCH PROPER AUTHORIZATION.

GENERAL NOTES:

EXISTING SERVICES AND UTILITIES SHOWN ON THESE DRAWINGS ARE TAKEN FROM THE BEST AVAILABLE RECORDS, BUT MAY NOT BE COMPLETE OR TO DATE. CONTRACTOR SHALL VERIFY IN FIELD FOR LOCATION AND ELEVATION OF PIPES AND CHECK WITH THE UTILITY COMPANIES BEFORE DIGGING OR PERFORMING WORK.

CONTRACTOR IS ADVISED TO COLLECT INFORMATION ON SOIL CONDITIONS BEFORE START OF CONSTRUCTION.

THE ENGINEER WAIVES ANY AND ALL RESPONSIBILITY AND LIABILITY FOR PROBLEMS WHICH ARISE FROM FAILURE TO FOLLOW THESE PLANS, SPECIFICATIONS AND THE DESIGN INTENT THEY CONVEY, OR FOR PROBLEMS WHICH ARISE FROM OTHERS' FAILURE TO OBTAIN AND/OR FOLLOW THE ENGINEER'S GUIDANCE WITH RESPECT TO ANY ERRORS, OMISSIONS, INCONSISTENCIES, AMBIGUITIES OR CONFLICTS WHICH ARE ALLEGED.

CONTRACTOR TO VERIFY ALL DIMENSIONS AND NOTIFY THE ENGINEER OF ANY DISCREPANCIES BEFORE WORK COMMENCES. DO NOT SCALE DRAWINGS.

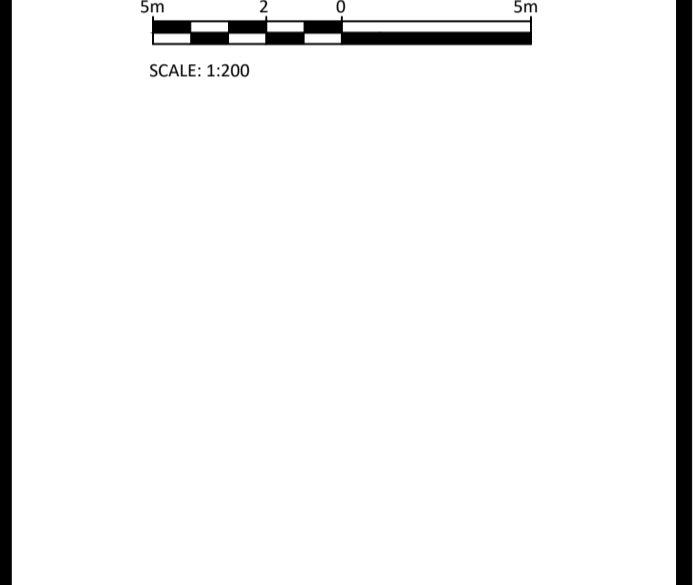

No.	REVISIONS	BY	DATE
04	RE-ISSUED FOR APPROVAL	M.L.	MAR 04 2024
03	RE-ISSUED FOR APPROVAL	M.L.	FEB 15 2024
02	RE-ISSUED FOR APPROVAL	M.L.	NOV 13 2023
01	ISSUED FOR APPROVAL	M.L.	JUNE 16 2023



NOT AUTHENTIC UNLESS SIGNED AND DATED



CLIENT: HALO CAR WASH

DESIGNED BY: M.L. DRAWN BY: M.L. APPROVED BY: M.B.

PROJECT: PROPOSED DEVELOPMENT HALO CAR WASH 3095 PALLADIUM DRIVE KANATA, ON

DRAWING TITLE: GRADING AND DRAINAGE PLAN

PROJECT NO: 230273
 DATE: MAY 2023
 C301

BLOCK 14

LEGEND:

- EXISTING PROPERTY LINE TO REMAIN
- PROPOSED CURB
- PROPOSED DEPRESSED CURB
- PROPOSED TERRACING (3:1 MIN.)
- PROPOSED SILT FENCE AS PER OPSD 219.110
- PROPOSED DOOR ENTRANCE/EXIT
- PROPOSED GRASS AREA (100mm TOP SOIL & SOD)
- PROPOSED CONCRETE FEATURES/SLAB
- PROPOSED HEAVY DUTY ASPHALT
- PROPOSED LIGHT DUTY ASPHALT
- PROPOSED RIP RAP
- PROPOSED ELEVATION
- PROPOSED HIGH POINT ELEVATION
- PROPOSED BOTTOM OF CURB / ASPHALT ELEVATION
- PROPOSED TOP OF CURB ELEVATION
- PROPOSED EXPOSED BOTTOM OF RETAINING WALL
- PROPOSED TOP OF RETAINING WALL
- MATCH INTO EXISTING ELEVATION
- EXISTING ELEVATION
- PROPOSED OVERLAND MAJOR FLOW ROUTE
- STM - STM - PROPOSED STORM SEWER
- SAN - SAN - PROPOSED SANITARY SEWER
- WTR - WTR - PROPOSED WATERMAIN
- STM - STM - EXISTING STORM SEWER
- SAN - SAN - EXISTING SANITARY SEWER
- WTR - WTR - EXISTING WATERMAIN
- GAS - GAS - EXISTING GAS LINE
- EXISTING MANHOLE
- EXISTING CATCHBASIN
- PROPOSED CATCHBASIN-MANHOLE/CATCHBASIN
- PROPOSED MANHOLE
- PROPOSED CURB STOP
- PROPOSED PIPE INSULATION
- PROPOSED 100 YEAR HIGH WATER LEVEL
- STORM WATERSHED EXTENT
- WS-XX CONTROLLED - WATERSHED NAME
- AREA RUNOFF - RUNOFF COEFFICIENT
- AREA IN HECTARES - AREA IN HECTARES

USE AND INTERPRETATION OF DRAWINGS

GENERAL CONDITIONS OF THE CONTRACT FOR CONSTRUCTION ARE PART OF THE CONTRACT DOCUMENTS AND DESCRIBE USE AND INTENT OF THE DRAWING. THE CONTRACTOR SHALL BE RESPONSIBLE FOR OBTAINING ALL NECESSARY PERMITS AND APPROVALS FROM THE LOCAL AUTHORITY. THE CONTRACTOR SHALL BE RESPONSIBLE FOR OBTAINING ALL NECESSARY PERMITS AND APPROVALS FROM THE LOCAL AUTHORITY. THE CONTRACTOR SHALL BE RESPONSIBLE FOR OBTAINING ALL NECESSARY PERMITS AND APPROVALS FROM THE LOCAL AUTHORITY.

BY USE OF THE DRAWINGS FOR CONSTRUCTION OF THE PROJECT, THE OWNER AGREES TO WAIVE ANY CLAIM AGAINST LRL AND TO RELEASE LRL FROM ANY LIABILITY ARISING DIRECTLY OR INDIRECTLY FROM SUCH UNAUTHORIZED CHANGES.

IN THE EVENT THE CLIENT, THE CLIENT'S CONTRACTORS OR SUBCONTRACTORS, OR ANYONE FOR WHOM THE CLIENT IS LEGALLY LIABLE MAKES OR PERMITS TO BE MADE ANY CHANGES TO ANY REPORTS, PLANS, SPECIFICATIONS OR OTHER CONSTRUCTION DOCUMENTS PREPARED BY LRL ASSOCIATES LTD. (LRL) WITHOUT OBTAINING LRL'S PRIOR WRITTEN CONSENT, THE CLIENT SHALL ASSUME FULL RESPONSIBILITY FOR THE RESULTS OF SUCH CHANGES. THEREFORE THE CLIENT AGREES TO WAIVE ANY CLAIM AGAINST LRL AND TO RELEASE LRL FROM ANY LIABILITY ARISING DIRECTLY OR INDIRECTLY FROM SUCH UNAUTHORIZED CHANGES.

IN ADDITION, THE CLIENT AGREES TO INCLUDE IN ANY CONTRACTS FOR CONSTRUCTION APPROPRIATE LANGUAGE THAT PROHIBITS THE CONTRACTOR OR ANY SUBCONTRACTORS OF ANY TIER FROM MAKING ANY CHANGES OR MODIFICATIONS TO LRL'S CONSTRUCTION DOCUMENTS WITHOUT THE PRIOR WRITTEN APPROVAL OF LRL AND THAT FURTHER REQUIRES THE CONTRACTOR TO INDEMNIFY BOTH LRL AND THE CLIENT FROM ANY LIABILITY OR COST ARISING FROM SUCH CHANGES MADE WITHOUT SUCH PROPER AUTHORIZATION.

GENERAL NOTES:

EXISTING SERVICES AND UTILITIES SHOWN ON THESE DRAWINGS ARE TAKEN FROM THE BEST AVAILABLE RECORDS, BUT MAY NOT BE COMPLETE OR TO DATE. CONTRACTOR SHALL VERIFY LOCATION AND ELEVATION OF PIPES AND CHECK WITH THE UTILITY COMPANIES BEFORE DIGGING OR PERFORMING WORK.

CONTRACTOR IS ADVISED TO COLLECT INFORMATION ON SOIL CONDITIONS BEFORE START OF CONSTRUCTION.

THE ENGINEER WAIVES ANY AND ALL RESPONSIBILITY AND LIABILITY FOR PROBLEMS WHICH ARISE FROM FAILURE TO FOLLOW THESE PLANS, SPECIFICATIONS AND THE DESIGN INTENT. THE CLIENT SHALL ASSUME FULL RESPONSIBILITY FOR THE RESULTS OF SUCH CHANGES. THEREFORE THE CLIENT AGREES TO WAIVE ANY CLAIM AGAINST LRL AND TO RELEASE LRL FROM ANY LIABILITY ARISING DIRECTLY OR INDIRECTLY FROM SUCH UNAUTHORIZED CHANGES.

CONTRACTOR TO VERIFY ALL DIMENSIONS AND NOTIFY THE ENGINEER OF ANY DISCREPANCIES BEFORE WORK COMMENCES. DO NOT SCALE DRAWINGS.



No.	REVISIONS	BY	DATE
04	RE-ISSUED FOR APPROVAL	M.L.	MAR 04 2024
03	RE-ISSUED FOR APPROVAL	M.L.	FEB 15 2024
02	RE-ISSUED FOR APPROVAL	M.L.	NOV 13 2023
01	ISSUED FOR APPROVAL	M.L.	JUNE 16 2023



NOT AUTHENTIC UNLESS SIGNED AND DATED

LRL
ENGINEERING | INGÉNIERIE
5430 Canotek Road | Ottawa, ON, K1J 9G2
www.lrl.ca | (613) 842-3434

CLIENT: HALO CAR WASH

DESIGNED BY: M.L. DRAWN BY: M.L. APPROVED BY: M.B.

PROJECT: PROPOSED DEVELOPMENT HALO CAR WASH 3095 PALLADIUM DRIVE KANATA, ON

DRAWING TITLE: SERVICING PLAN

PROJECT NO: 230273
DATE: MAY 2023

C402

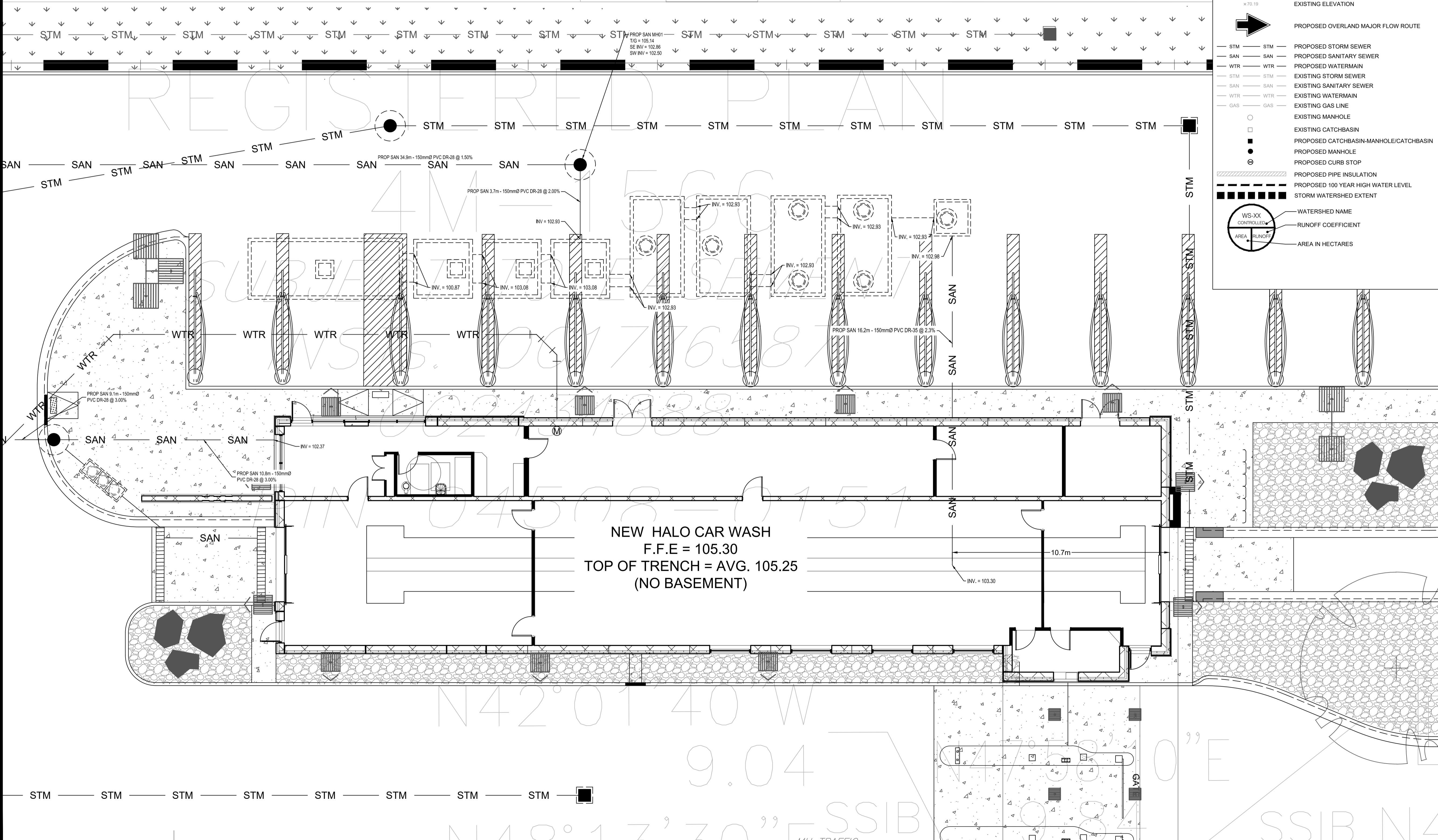

NEW HALO CAR WASH
F.F.E = 105.30
TOP OF TRENCH = AVG. 105.25
(NO BASEMENT)

10.7m

INV. = 103.30

STM STM STM STM STM STM STM STM

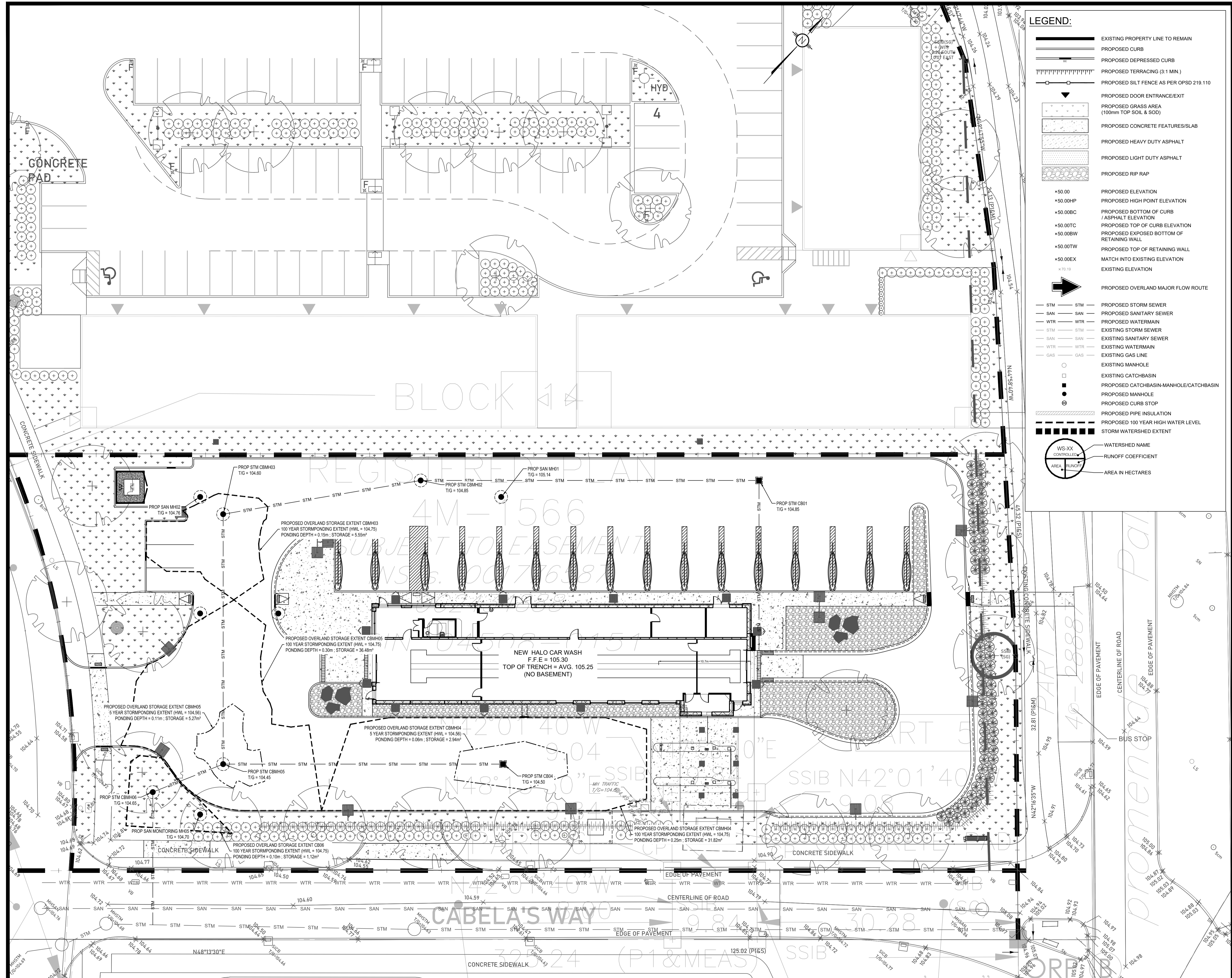

LEGEND:

- EXISTING PROPERTY LINE TO REMAIN
- PROPOSED CURB
- PROPOSED DEPRESSED CURB
- PROPOSED TERRACING (3:1 MIN.)
- PROPOSED SILT FENCE AS PER OPSD 219.110
- PROPOSED DOOR ENTRANCE/EXIT
- PROPOSED GRASS AREA (100mm TOP SOIL & SOD)
- PROPOSED CONCRETE FEATURES/SLAB
- PROPOSED HEAVY DUTY ASPHALT
- PROPOSED LIGHT DUTY ASPHALT
- PROPOSED RIP RAP
- PROPOSED ELEVATION
- PROPOSED HIGH POINT ELEVATION
- PROPOSED BOTTOM OF CURB / ASPHALT ELEVATION
- PROPOSED TOP OF CURB ELEVATION
- PROPOSED EXPOSED BOTTOM OF RETAINING WALL
- PROPOSED TOP OF RETAINING WALL
- MATCH INTO EXISTING ELEVATION
- EXISTING ELEVATION
- PROPOSED OVERLAND MAJOR FLOW ROUTE
- PROPOSED STORM SEWER
- PROPOSED SANITARY SEWER
- PROPOSED WATERMAIN
- EXISTING STORM SEWER
- EXISTING SANITARY SEWER
- EXISTING WATERMAIN
- EXISTING GAS LINE
- EXISTING MANHOLE
- EXISTING CATCHBASIN
- PROPOSED CATCHBASIN-MANHOLE/CATCHBASIN
- PROPOSED MANHOLE
- PROPOSED CURB STOP
- PROPOSED PIPE INSULATION
- PROPOSED 100 YEAR HIGH WATER LEVEL
- STORM WATERSHED EXTENT
- WATERSHED NAME
- RUNOFF COEFFICIENT
- AREA IN HECTARES

USE AND INTERPRETATION OF DRAWINGS

GENERAL CONDITIONS OF THE CONTRACT FOR CONSTRUCTION ARE PART OF THE CONTRACT DOCUMENTS AND DESCRIBE USE AND INTENT OF THE DRAWING. THE CONTRACT DOCUMENTS INCLUDE NOT ONLY THE DRAWINGS, BUT ALSO THE OWNER-CONTRACTOR AGREEMENTS, CONDITIONS OF THE CONTRACT, THE SPECIFICATIONS, ADDENDA, AND MODIFICATIONS ISSUED AFTER EXECUTION OF THE CONTRACT. THESE CONTRACT DOCUMENTS ARE COMPLEMENTARY, AND WHAT IS REQUIRED BY ANY ONE SHALL BE BINDING AS REQUIRED BY ALL. WORK NOT COMPLETELY DELINEATED HEREON SHALL BE CONSTRUCTED OF THE SAME MATERIALS AND DETAILED SIMILARLY AS WORK SHOWN MORE COMPLETELY ELSEWHERE IN THE CONTRACT DOCUMENTS.

BY USE OF THE DRAWINGS FOR CONSTRUCTION OF THE PROJECT, THE OWNER CONFIRMS THAT HE HAS REVIEWED AND APPROVED THE DRAWINGS. THE CONTRACTOR CONFIRMS THAT HE HAS VISITED THE SITE, FAMILIARIZED HIMSELF WITH THE LOCAL CONDITIONS, VERIFIED FIELD DIMENSIONS AND CORRELATED HIS OBSERVATIONS WITH THE REQUIREMENTS OF THE CONTRACT DOCUMENTS.

AS INSTRUMENTS OF SERVICE, ALL DRAWINGS, SPECIFICATIONS, CAD FILES OR OTHER ELECTRONIC MEDIA AND COPIES THERE OF FURNISHED BY THE ENGINEER ARE HIS PROPERTY. THEY ARE TO BE USED ONLY FOR THIS PROJECT AND ARE NOT TO BE USED ON ANY OTHER PROJECT, INCLUDING REPEATS OF THE PROJECT. CHANGES TO THE DRAWINGS MAY ONLY BE MADE BY THE ENGINEER.

UNLESS THE REVISION TITLE IS "ISSUED FOR CONSTRUCTION", THESE DRAWINGS SHALL BE CONSIDERED PRELIMINARY AND SHALL NOT BE USED AS A CONSTRUCTION DOCUMENT.

THESE DRAWINGS ILLUSTRATE THE WORK TO BE DONE. THE ENGINEER IS NOT RESPONSIBLE FOR THE MEANS, METHODS, TECHNIQUES, SEQUENCES, AND PROCEDURES USED TO DO THE WORK, OR THE SAFETY ASPECTS OF CONSTRUCTION, AND NOTHING ON THESE DRAWINGS EXPRESSED OR IMPLIED CHANGES THIS CONDITION. CONTRACTOR SHALL DETERMINE ALL CONDITIONS AT THE SITE AND SHALL BE RESPONSIBLE FOR KNOWING HOW THEY AFFECT THE WORK. SUBMITTAL OF A BID TO PERFORM THIS WORK IS ACKNOWLEDGEMENT OF THE RESPONSIBILITIES, AND THAT THEY HAVE BEEN FULLY CONSIDERED IN PLANNING OF THE WORK, AND THE BID PRICE. NO CLAIMS FOR EXTRA CHARGES DUE TO THESE CONDITIONS WILL BE FORTHCOMING.

UNAUTHORIZED CHANGES:

IN THE EVENT THE CLIENT, THE CLIENT'S CONTRACTORS OR SUBCONTRACTORS, OR ANYONE FOR WHOM THE CLIENT IS LEGALLY LIABLE MAKES OR PERMITS TO BE MADE ANY CHANGES TO ANY REPORTS, PLANS, SPECIFICATIONS OR OTHER CONSTRUCTION DOCUMENTS PREPARED BY LRL ASSOCIATES LTD. (LRL) WITHOUT OBTAINING LRL'S PRIOR WRITTEN CONSENT, THE CLIENT SHALL ASSUME FULL RESPONSIBILITY FOR THE RESULTS OF SUCH CHANGES. THEREFORE THE CLIENT AGREES TO WAIVE ANY CLAIM AGAINST LRL AND TO RELEASE LRL FROM ANY LIABILITY ARISING DIRECTLY OR INDIRECTLY FROM SUCH UNAUTHORIZED CHANGES.

IN ADDITION, THE CLIENT AGREES, TO THE FULLEST EXTENT PERMITTED BY LAW, TO INDEMNIFY AND HOLD HARMLESS LRL FROM ANY DAMAGES, LIABILITIES OR COST, INCLUDING REASONABLE ATTORNEY'S FEES AND COST OF DEFENSE, ARISING FROM SUCH CHANGES.

IN ADDITION, THE CLIENT AGREES TO INCLUDE IN ANY CONTRACTS FOR CONSTRUCTION APPROPRIATE LANGUAGE THAT PROHIBITS THE CONTRACTOR OR ANY SUBCONTRACTORS OF ANY TIER FROM MAKING ANY CHANGES OR MODIFICATIONS TO LRL'S CONSTRUCTION DOCUMENTS WITHOUT THE PRIOR WRITTEN APPROVAL OF LRL AND THAT FURTHER REQUIRES THE CONTRACTOR TO INDEMNIFY BOTH LRL AND THE CLIENT FROM ANY LIABILITY OR COST ARISING FROM SUCH CHANGES MADE WITHOUT SUCH PROPER AUTHORIZATION.

GENERAL NOTES:

EXISTING SERVICES AND UTILITIES SHOWN ON THESE DRAWINGS ARE TAKEN FROM THE BEST AVAILABLE RECORDS, BUT MAY NOT BE COMPLETE OR TO DATE. CONTRACTOR SHALL VERIFY IN FIELD FOR LOCATION AND ELEVATION OF PIPES AND CHECK WITH THE UTILITY COMPANIES BEFORE DIGGING OR PERFORMING WORK.

CONTRACTOR IS ADVISED TO COLLECT INFORMATION ON SOIL CONDITIONS BEFORE START OF CONSTRUCTION.

THE ENGINEER WAIVES ANY AND ALL RESPONSIBILITY AND LIABILITY FOR PROBLEMS WHICH ARISE FROM FAILURE TO FOLLOW THESE PLANS, SPECIFICATIONS AND THE DESIGN INTENT THEY CONVEY, OR FOR PROBLEMS WHICH ARISE FROM OTHERS' FAILURE TO OBTAIN AND/OR FOLLOW THE ENGINEER'S GUIDANCE WITH RESPECT TO ANY ERRORS, OMISSIONS, INCONSISTENCIES, AMBIGUITIES OR CONFLICTS WHICH ARE ALLEGED.

CONTRACTOR TO VERIFY ALL DIMENSIONS AND NOTIFY THE ENGINEER OF ANY DISCREPANCIES BEFORE WORK COMMENCES. DO NOT SCALE DRAWINGS.

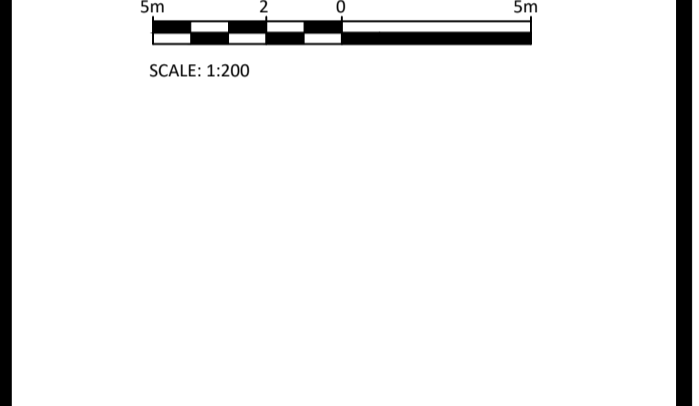

No.	REVISIONS	BY	DATE
04	RE-ISSUED FOR APPROVAL	M.L.	MAR 04 2024
03	RE-ISSUED FOR APPROVAL	M.L.	FEB 15 2024
02	RE-ISSUED FOR APPROVAL	M.L.	NOV 13 2023
01	ISSUED FOR APPROVAL	M.L.	JUNE 16 2023



NOT AUTHENTIC UNLESS SIGNED AND DATED

LRL
 ENGINEERING | INGENIERIE
 5430 Canotek Road | Ottawa, ON, K1J 9G2
 www.lrl.ca | (613) 842-3434

CLIENT: **HALO CAR WASH**

DESIGNED BY: M.L. DRAWN BY: M.L. APPROVED BY: M.B.

PROJECT: **PROPOSED DEVELOPMENT HALO CAR WASH 3095 PALLADIUM DRIVE KANATA, ON**

DRAWING TITLE: **STORMWATER MANAGEMENT PLAN**

PROJECT NO: 230273
 DATE: MAY 2023

C601

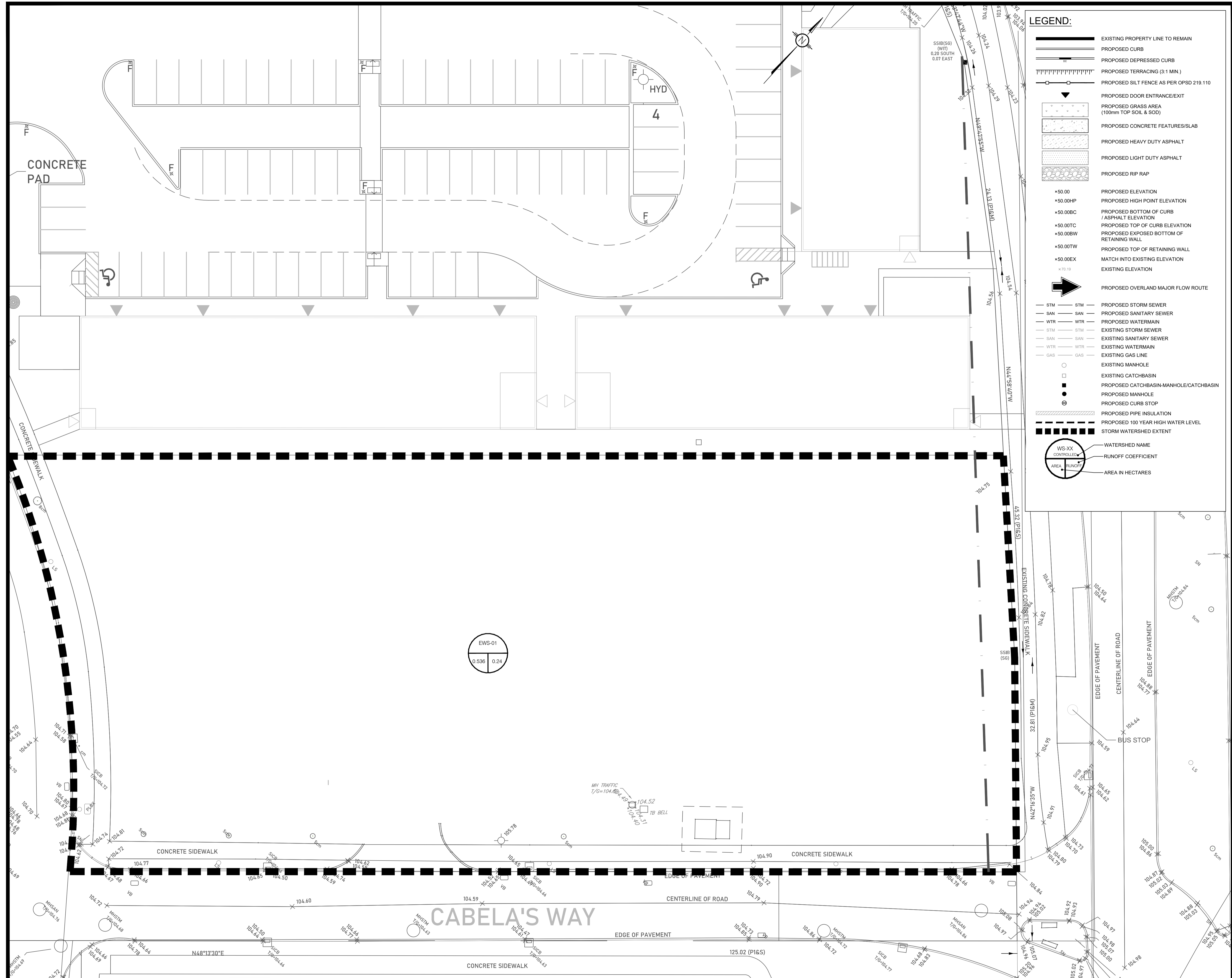

LEGEND:

- EXISTING PROPERTY LINE TO REMAIN
- PROPOSED CURB
- PROPOSED DEPRESSED CURB
- PROPOSED TERRACING (3:1 MIN.)
- PROPOSED SILT FENCE AS PER OPSD 219.110
- PROPOSED DOOR ENTRANCE/EXIT
- PROPOSED GRASS AREA (100mm TOP SOIL & SOD)
- PROPOSED CONCRETE FEATURES/SLAB
- PROPOSED HEAVY DUTY ASPHALT
- PROPOSED LIGHT DUTY ASPHALT
- PROPOSED RIP RAP
- PROPOSED ELEVATION
- PROPOSED HIGH POINT ELEVATION
- PROPOSED BOTTOM OF CURB / ASPHALT ELEVATION
- PROPOSED TOP OF CURB ELEVATION
- PROPOSED EXPOSED BOTTOM OF RETAINING WALL
- PROPOSED TOP OF RETAINING WALL
- MATCH INTO EXISTING ELEVATION
- PROPOSED OVERLAND MAJOR FLOW ROUTE
- PROPOSED STORM SEWER
- PROPOSED SANITARY SEWER
- PROPOSED WATERMAIN
- EXISTING STORM SEWER
- EXISTING SANITARY SEWER
- EXISTING WATERMAIN
- EXISTING GAS LINE
- EXISTING MANHOLE
- EXISTING CATCHBASIN
- PROPOSED CATCHBASIN-MANHOLE/CATCHBASIN
- PROPOSED MANHOLE
- PROPOSED CURB STOP
- PROPOSED PIPE INSULATION
- PROPOSED 100 YEAR HIGH WATER LEVEL
- STORM WATERSHED EXTENT
- WATERSHED NAME
- RUNOFF COEFFICIENT
- AREA IN HECTARES

USE AND INTERPRETATION OF DRAWINGS

GENERAL CONDITIONS OF THE CONTRACT FOR CONSTRUCTION ARE PART OF THE CONTRACT DOCUMENTS AND DESCRIBE USE AND INTENT OF THE DRAWING. THE CONTRACT DOCUMENTS INCLUDE NOT ONLY THE DRAWINGS, BUT ALSO THE OWNER-CONTRACTOR AGREEMENTS, CONDITIONS OF THE CONTRACT, THE SPECIFICATIONS, ADDENDA, AND MODIFICATIONS ISSUED AFTER EXECUTION OF THE CONTRACT. THESE CONTRACT DOCUMENTS ARE COMPLEMENTARY, AND WHAT IS REQUIRED BY ANY ONE SHALL BE BINDING AS REQUIRED BY ALL. WORK NOT COMPLETELY DELINEATED HEREON SHALL BE CONSTRUCTED OF THE SAME MATERIALS AND DETAILED SIMILARLY AS WORK SHOWN MORE COMPLETELY ELSEWHERE IN THE CONTRACT DOCUMENTS.

BY USE OF THE DRAWINGS FOR CONSTRUCTION OF THE PROJECT, THE OWNER CONFIRMS THAT HE HAS REVIEWED AND APPROVED THE DRAWINGS. THE CONTRACTOR CONFIRMS THAT HE HAS VISITED THE SITE, FAMILIARIZED HIMSELF WITH THE LOCAL CONDITIONS, VERIFIED FIELD DIMENSIONS AND CORRELATED HIS OBSERVATIONS WITH THE REQUIREMENTS OF THE CONTRACT DOCUMENTS.

AS INSTRUMENTS OF SERVICE, ALL DRAWINGS, SPECIFICATIONS, CAD FILES OR OTHER ELECTRONIC MEDIA AND COPIES THERE OF FURNISHED BY THE ENGINEER ARE HIS PROPERTY. THEY ARE TO BE USED ONLY FOR THIS PROJECT AND ARE NOT TO BE USED ON ANY OTHER PROJECT, INCLUDING REPEATS OF THE PROJECT. CHANGES TO THE DRAWINGS MAY ONLY BE MADE BY THE ENGINEER.

UNLESS THE REVISION TITLE IS "ISSUED FOR CONSTRUCTION", THESE DRAWINGS SHALL BE CONSIDERED PRELIMINARY AND SHALL NOT BE USED AS A CONSTRUCTION DOCUMENT.

THESE DRAWINGS ILLUSTRATE THE WORK TO BE DONE. THE ENGINEER IS NOT RESPONSIBLE FOR THE MEANS, METHODS, TECHNIQUES, SEQUENCES, AND PROCEDURES USED TO DO THE WORK, OR THE SAFETY ASPECTS OF CONSTRUCTION, AND NOTHING ON THESE DRAWINGS EXPRESSED OR IMPLIED CHANGES THIS CONDITION. CONTRACTOR SHALL DETERMINE ALL CONDITIONS AT THE SITE AND SHALL BE RESPONSIBLE FOR KNOWING HOW THEY AFFECT THE WORK. SUBMITTAL OF A BID TO PERFORM THIS WORK IS ACKNOWLEDGEMENT OF THE RESPONSIBILITIES, AND THAT THEY HAVE BEEN FULLY CONSIDERED IN PLANNING OF THE WORK, AND THE BID PRICE. NO CLAIMS FOR EXTRA CHARGES DUE TO THESE CONDITIONS WILL BE FORTHCOMING.

UNAUTHORIZED CHANGES:

IN THE EVENT THE CLIENT, THE CLIENT'S CONTRACTORS OR SUBCONTRACTORS, OR ANYONE FOR WHOM THE CLIENT IS LEGALLY LIABLE MAKES OR PERMITS TO BE MADE ANY CHANGES TO ANY REPORTS, PLANS, SPECIFICATIONS OR OTHER CONSTRUCTION DOCUMENTS PREPARED BY LRL ASSOCIATES LTD. (LRL) WITHOUT OBTAINING LRL'S PRIOR WRITTEN CONSENT, THE CLIENT SHALL ASSUME FULL RESPONSIBILITY FOR THE RESULTS OF SUCH CHANGES. THEREFORE THE CLIENT AGREES TO WAIVE ANY CLAIM AGAINST LRL AND TO RELEASE LRL FROM ANY LIABILITY ARISING DIRECTLY OR INDIRECTLY FROM SUCH UNAUTHORIZED CHANGES.

IN ADDITION, THE CLIENT AGREES, TO THE FULLEST EXTENT PERMITTED BY LAW, TO INDEMNIFY AND HOLD HARMLESS LRL FROM ANY DAMAGES, LIABILITIES OR COST, INCLUDING REASONABLE ATTORNEY'S FEES AND COST OF DEFENSE, ARISING FROM SUCH CHANGES.

IN ADDITION, THE CLIENT AGREES TO INCLUDE IN ANY CONTRACTS FOR CONSTRUCTION APPROPRIATE LANGUAGE THAT PROHIBITS THE CONTRACTOR OR ANY SUBCONTRACTORS OF ANY TIER FROM MAKING ANY CHANGES OR MODIFICATIONS TO LRL'S CONSTRUCTION DOCUMENTS WITHOUT THE PRIOR WRITTEN APPROVAL OF LRL AND THAT FURTHER REQUIRES THE CONTRACTOR TO INDEMNIFY BOTH LRL AND THE CLIENT FROM ANY LIABILITY OR COST ARISING FROM SUCH CHANGES MADE WITHOUT SUCH PROPER AUTHORIZATION.

GENERAL NOTES:

EXISTING SERVICES AND UTILITIES SHOWN ON THESE DRAWINGS ARE TAKEN FROM THE BEST AVAILABLE RECORDS, BUT MAY NOT BE COMPLETE OR TO DATE. CONTRACTOR SHALL VERIFY IN FIELD FOR LOCATION AND ELEVATION OF PIPES AND CHECK WITH THE UTILITY COMPANIES BEFORE DIGGING OR PERFORMING WORK.

CONTRACTOR IS ADVISED TO COLLECT INFORMATION ON SOIL CONDITIONS BEFORE START OF CONSTRUCTION.

THE ENGINEER WAIVES ANY AND ALL RESPONSIBILITY AND LIABILITY FOR PROBLEMS WHICH ARISE FROM FAILURE TO FOLLOW THESE PLANS, SPECIFICATIONS AND THE DESIGN INTENT THEY CONVEY, OR FOR PROBLEMS WHICH ARISE FROM OTHERS' FAILURE TO OBTAIN AND/OR FOLLOW THE ENGINEER'S GUIDANCE WITH RESPECT TO ANY ERRORS, OMISSIONS, INCONSISTENCIES, AMBIGUITIES OR CONFLICTS WHICH ARE ALLEGED.

CONTRACTOR TO VERIFY ALL DIMENSIONS AND NOTIFY THE ENGINEER OF ANY DISCREPANCIES BEFORE WORK COMMENCES. DO NOT SCALE DRAWINGS.

Scale: 1:200

No.	REVISIONS	BY	DATE
04	RE-ISSUED FOR APPROVAL	M.L.	MAR 04 2024
03	RE-ISSUED FOR APPROVAL	M.L.	FEB 15 2024
02	RE-ISSUED FOR APPROVAL	M.L.	NOV 13 2023
01	ISSUED FOR APPROVAL	M.L.	JUNE 16 2023



NOT AUTHENTIC UNLESS SIGNED AND DATED

LRL
ENGINEERING | INGÉNIÉRIE
5430 Canotek Road | Ottawa, ON, K1J 9G2
www.lrl.ca | (613) 842-3434

CLIENT: HALO CAR WASH

DESIGNED BY: M.L. DRAWN BY: M.L. APPROVED BY: M.B.

PROJECT: PROPOSED DEVELOPMENT HALO CAR WASH 3095 PALLADIUM DRIVE KANATA, ON

DRAWING TITLE: PRE-DEVELOPMENT WATERSHED PLAN

PROJECT NO: 230273
DATE: MAY 2023

C701

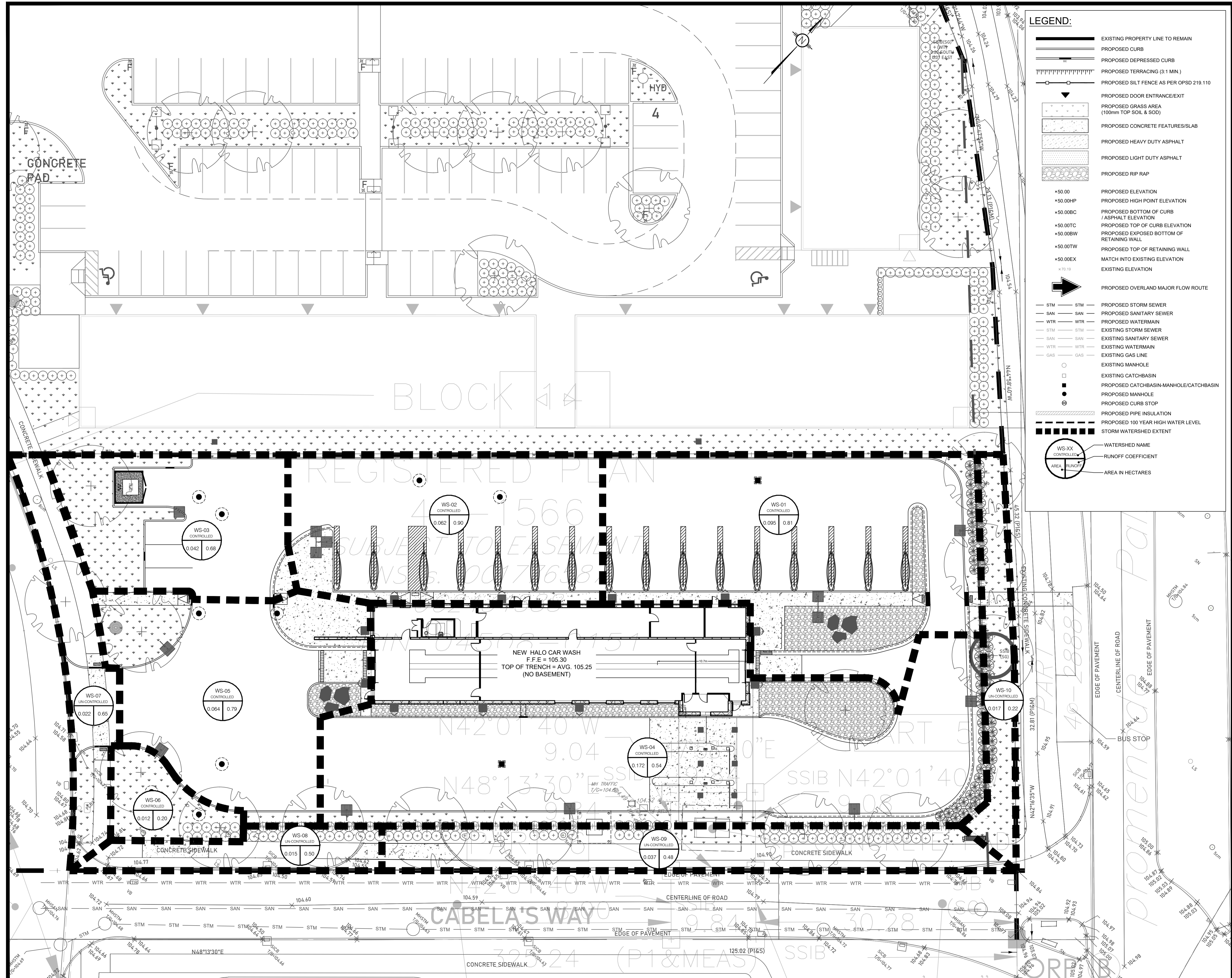

LEGEND:

- EXISTING PROPERTY LINE TO REMAIN
- PROPOSED CURB
- PROPOSED DEPRESSED CURB
- PROPOSED TERRACING (3:1 MIN.)
- PROPOSED SILT FENCE AS PER OPSD 219.110
- PROPOSED DOOR ENTRANCE/EXIT
- PROPOSED GRASS AREA (100MM TOP SOIL & SOD)
- PROPOSED CONCRETE FEATURES/SLAB
- PROPOSED HEAVY DUTY ASPHALT
- PROPOSED LIGHT DUTY ASPHALT
- PROPOSED RIP RAP
- PROPOSED ELEVATION
- PROPOSED HIGH POINT ELEVATION
- PROPOSED BOTTOM OF CURB / ASPHALT ELEVATION
- PROPOSED TOP OF CURB ELEVATION
- PROPOSED EXPOSED BOTTOM OF RETAINING WALL
- PROPOSED TOP OF RETAINING WALL
- MATCH INTO EXISTING ELEVATION
- EXISTING ELEVATION
- PROPOSED OVERLAND MAJOR FLOW ROUTE
- PROPOSED STORM SEWER
- PROPOSED SANITARY SEWER
- PROPOSED WATERMAIN
- EXISTING STORM SEWER
- EXISTING SANITARY SEWER
- EXISTING WATERMAIN
- EXISTING GAS LINE
- EXISTING MANHOLE
- EXISTING CATCHBASIN
- PROPOSED CATCHBASIN-MANHOLE/CATCHBASIN
- PROPOSED MANHOLE
- PROPOSED CURB STOP
- PROPOSED PIPE INSULATION
- PROPOSED 100 YEAR HIGH WATER LEVEL
- STORM WATERSHED EXTENT
- WATERSHED NAME
- RUNOFF COEFFICIENT
- AREA IN HECTARES

USE AND INTERPRETATION OF DRAWINGS

GENERAL CONDITIONS OF THE CONTRACT FOR CONSTRUCTION ARE PART OF THE CONTRACT DOCUMENTS AND DESCRIBE USE AND INTENT OF THE DRAWING. THE CONTRACT DOCUMENTS INCLUDE NOT ONLY THE DRAWINGS, BUT ALSO THE OWNER-CONTRACTOR AGREEMENTS, CONDITIONS OF THE CONTRACT, THE SPECIFICATIONS, ADDENDA, AND MODIFICATIONS ISSUED AFTER EXECUTION OF THE CONTRACT. THESE CONTRACT DOCUMENTS ARE COMPLEMENTARY, AND WHAT IS REQUIRED BY ANY ONE SHALL BE BINDING AS REQUIRED BY ALL. WORK NOT COMPLETELY DELINEATED HEREON SHALL BE CONSTRUCTED OF THE SAME MATERIALS AND DETAIL AS SHOWN MORE COMPLETELY ELSEWHERE IN THE CONTRACT DOCUMENTS.

BY USE OF THE DRAWINGS FOR CONSTRUCTION OF THE PROJECT, THE OWNER CONFIRMS THAT HE HAS REVIEWED AND APPROVED THE DRAWINGS. THE CONTRACTOR CONFIRMS THAT HE HAS VISITED THE SITE, FAMILIARIZED HIMSELF WITH THE LOCAL CONDITIONS, VERIFIED FIELD DIMENSIONS AND CORRELATED HIS OBSERVATIONS WITH THE REQUIREMENTS OF THE CONTRACT DOCUMENTS.

AS INSTRUMENTS OF SERVICE, ALL DRAWINGS, SPECIFICATIONS, CAD FILES OR OTHER ELECTRONIC MEDIA AND COPIES THEREOF FURNISHED BY THE ENGINEER ARE HIS PROPERTY. THEY ARE TO BE USED ONLY FOR THIS PROJECT AND ARE NOT TO BE USED ON ANY OTHER PROJECT, INCLUDING REPEATS OF THE PROJECT. CHANGES TO THE DRAWINGS MAY ONLY BE MADE BY THE ENGINEER.

UNLESS THE REVISION TITLE IS ISSUED FOR CONSTRUCTION, THESE DRAWINGS SHALL BE CONSIDERED PRELIMINARY AND SHALL NOT BE USED AS A CONSTRUCTION DOCUMENT.

THESE DRAWINGS ILLUSTRATE THE WORK TO BE DONE. THE ENGINEER IS NOT RESPONSIBLE FOR THE MEANS, METHODS, TECHNIQUES, SEQUENCES, AND PROCEDURES USED TO DO THE WORK, OR THE SAFETY ASPECTS OF CONSTRUCTION, AND NOTHING ON THESE DRAWINGS EXPRESSED OR IMPLIED CHANGES THIS CONDITION. CONTRACTOR SHALL DETERMINE ALL CONDITIONS AT THE SITE AND SHALL BE RESPONSIBLE FOR KNOWING HOW THEY AFFECT THE WORK. SUBMITTAL OF A BID TO PERFORM THIS WORK IS ACKNOWLEDGEMENT OF THE RESPONSIBILITIES, AND THAT THEY HAVE BEEN FULLY CONSIDERED IN PLANNING OF THE WORK, AND THE BID PRICE. NO CLAIMS FOR EXTRA CHARGES DUE TO THESE CONDITIONS WILL BE FORTHCOMING.

UNAUTHORIZED CHANGES:

IN THE EVENT THE CLIENT, THE CLIENT'S CONTRACTORS OR SUBCONTRACTORS, OR ANYONE FOR WHOM THE CLIENT IS LEGALLY LIABLE MAKES OR PERMITS TO BE MADE ANY CHANGES TO ANY REPORTS, PLANS, SPECIFICATIONS OR OTHER CONSTRUCTION DOCUMENTS PREPARED BY LRL ASSOCIATES LTD. (LRL) WITHOUT OBTAINING LRL'S PRIOR WRITTEN CONSENT, THE CLIENT SHALL ASSUME FULL RESPONSIBILITY FOR THE RESULTS OF SUCH CHANGES. THEREFORE THE CLIENT AGREES TO WAIVE ANY CLAIM AGAINST LRL AND TO RELEASE LRL FROM ANY LIABILITY ARISING DIRECTLY OR INDIRECTLY FROM SUCH UNAUTHORIZED CHANGES.

IN ADDITION, THE CLIENT AGREES, TO THE FULLEST EXTENT PERMITTED BY LAW, TO INDEMNIFY AND HOLD HARMLESS LRL FROM ANY DAMAGES, LIABILITIES OR COSTS, INCLUDING REASONABLE ATTORNEY'S FEES AND COST OF DEFENSE, ARISING FROM SUCH CHANGES.

IN ADDITION, THE CLIENT AGREES TO INCLUDE IN ANY CONTRACTS FOR CONSTRUCTION APPROPRIATE LANGUAGE THAT PROHIBITS THE CONTRACTOR OR ANY SUBCONTRACTORS OF ANY TIER FROM MAKING ANY CHANGES OR MODIFICATIONS TO LRL'S CONSTRUCTION DOCUMENTS WITHOUT THE PRIOR WRITTEN APPROVAL OF LRL AND THAT FURTHER REQUIRES THE CONTRACTOR TO INDEMNIFY BOTH LRL AND THE CLIENT FROM ANY LIABILITY OR COST ARISING FROM SUCH CHANGES MADE WITHOUT SUCH PROPER AUTHORIZATION.

GENERAL NOTES:

EXISTING SERVICES AND UTILITIES SHOWN ON THESE DRAWINGS ARE TAKEN FROM THE BEST AVAILABLE RECORDS, BUT MAY NOT BE COMPLETE OR TO DATE. CONTRACTOR SHALL VERIFY IN FIELD FOR LOCATION AND ELEVATION OF PIPES AND CHECK WITH THE UTILITY COMPANIES BEFORE DIGGING OR PERFORMING WORK.

CONTRACTOR IS ADVISED TO COLLECT INFORMATION ON SOIL CONDITIONS BEFORE START OF CONSTRUCTION.

THE ENGINEER WAIVES ANY AND ALL RESPONSIBILITY AND LIABILITY FOR PROBLEMS WHICH ARISE FROM FAILURE TO FOLLOW THESE PLANS, SPECIFICATIONS AND THE DESIGN INTENT THEY CONVEY, OR FOR PROBLEMS WHICH ARISE FROM OTHERS' FAILURE TO OBTAIN AND/OR FOLLOW THE ENGINEER'S GUIDANCE WITH RESPECT TO ANY ERRORS, OMISSIONS, INCONSISTENCIES, AMBIGUITIES OR CONFLICTS WHICH ARE ALLEGED.

CONTRACTOR TO VERIFY ALL DIMENSIONS AND NOTIFY THE ENGINEER OF ANY DISCREPANCIES BEFORE WORK COMMENCES. DO NOT SCALE DRAWINGS.

SCALE: 1:200

No.	REVISIONS	BY	DATE
04	RE-ISSUED FOR APPROVAL	M.L.	MAR 04 2024
03	RE-ISSUED FOR APPROVAL	M.L.	FEB 15 2024
02	RE-ISSUED FOR APPROVAL	M.L.	NOV 13 2023
01	ISSUED FOR APPROVAL	M.L.	JUNE 16 2023



NOT AUTHENTIC UNLESS SIGNED AND DATED



LRL
ENGINEERING | INGÉNIERIE
5430 Canotek Road | Ottawa, ON, K1J 9G2
www.lrl.ca | (613) 842-3434

CLIENT
HALO CAR WASH

DESIGNED BY: M.L. DRAWN BY: M.L. APPROVED BY: M.B.

PROJECT
**PROPOSED DEVELOPMENT
HALO CAR WASH
3095 PALLADIUM DRIVE
KANATA, ON**

DRAWING TITLE
**POST-DEVELOPMENT
WATERSHED PLAN**

PROJECT NO.
230273

DATE
MAY 2023

C702

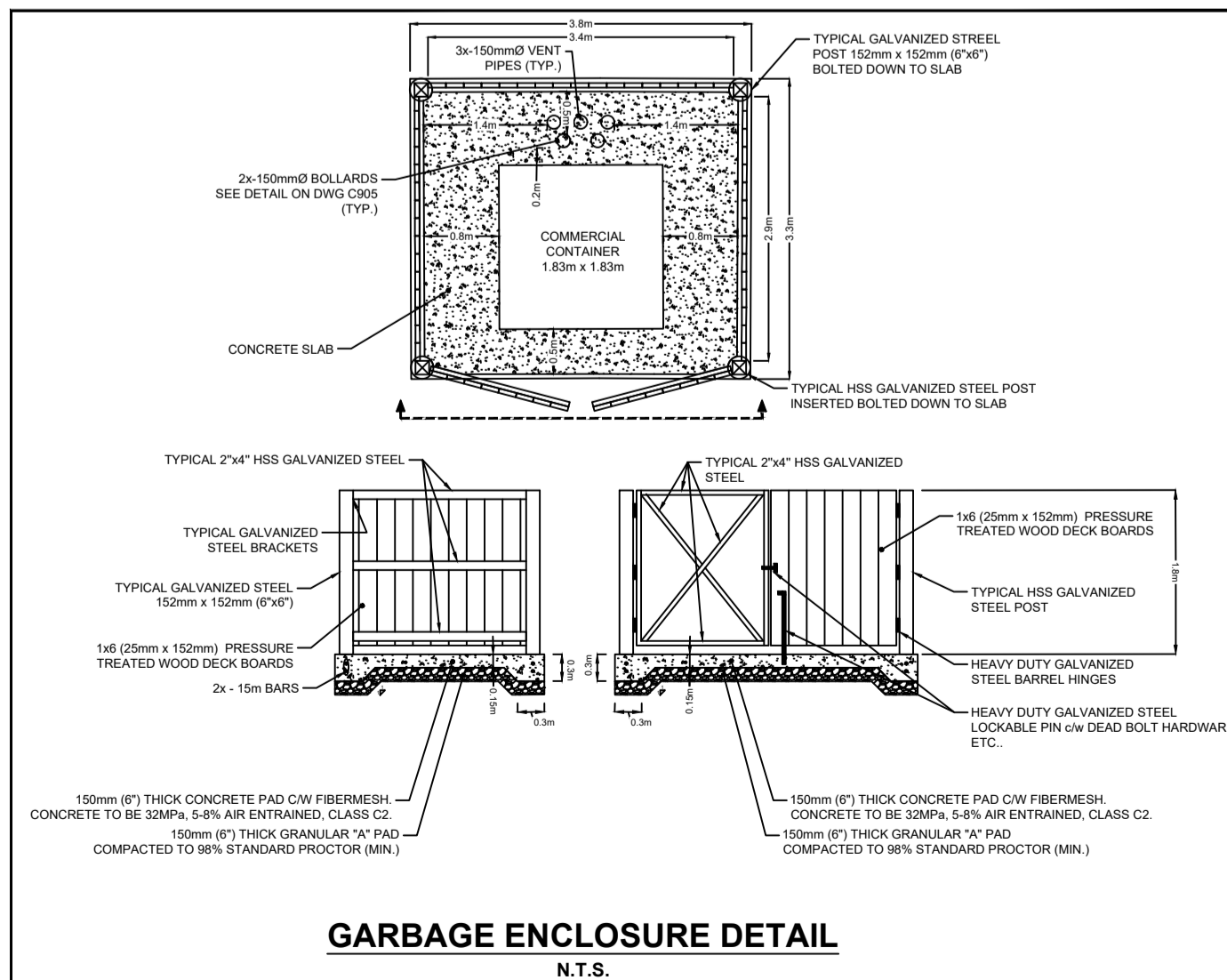
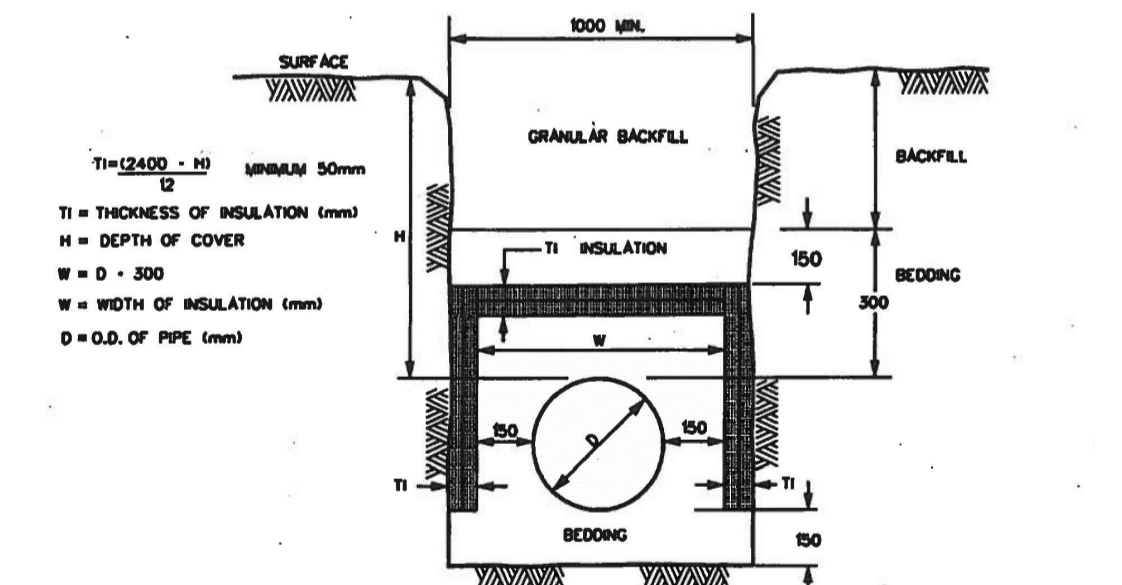
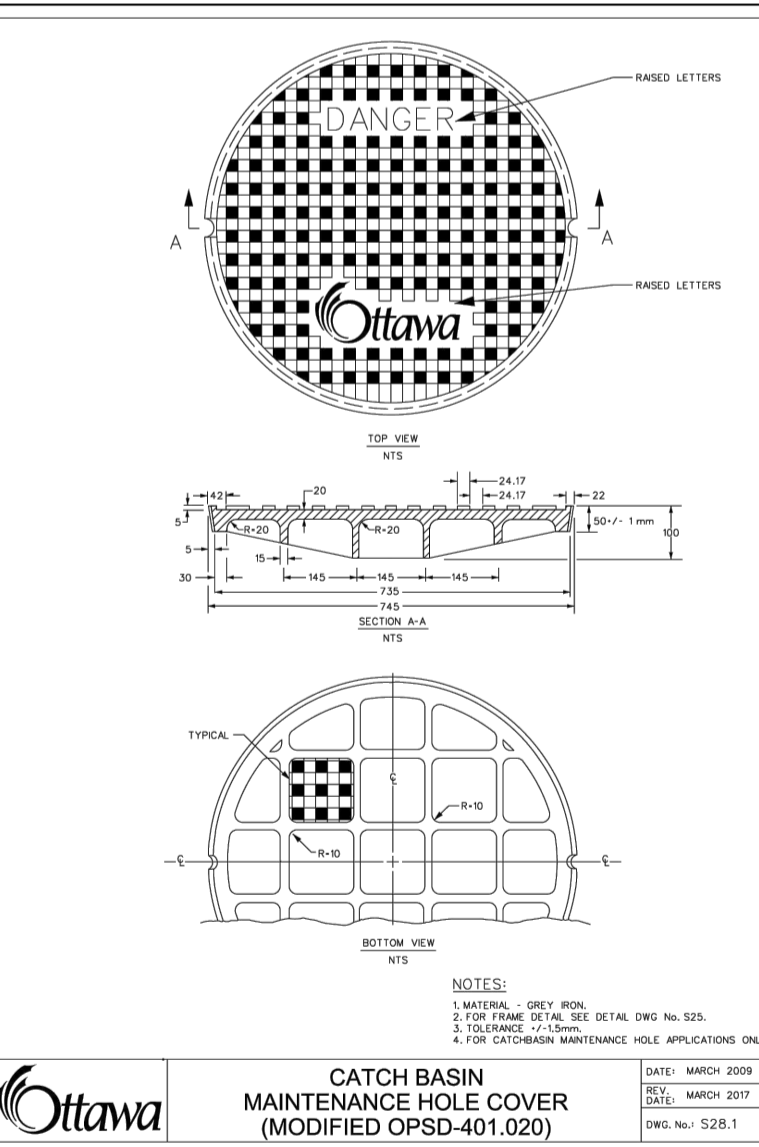
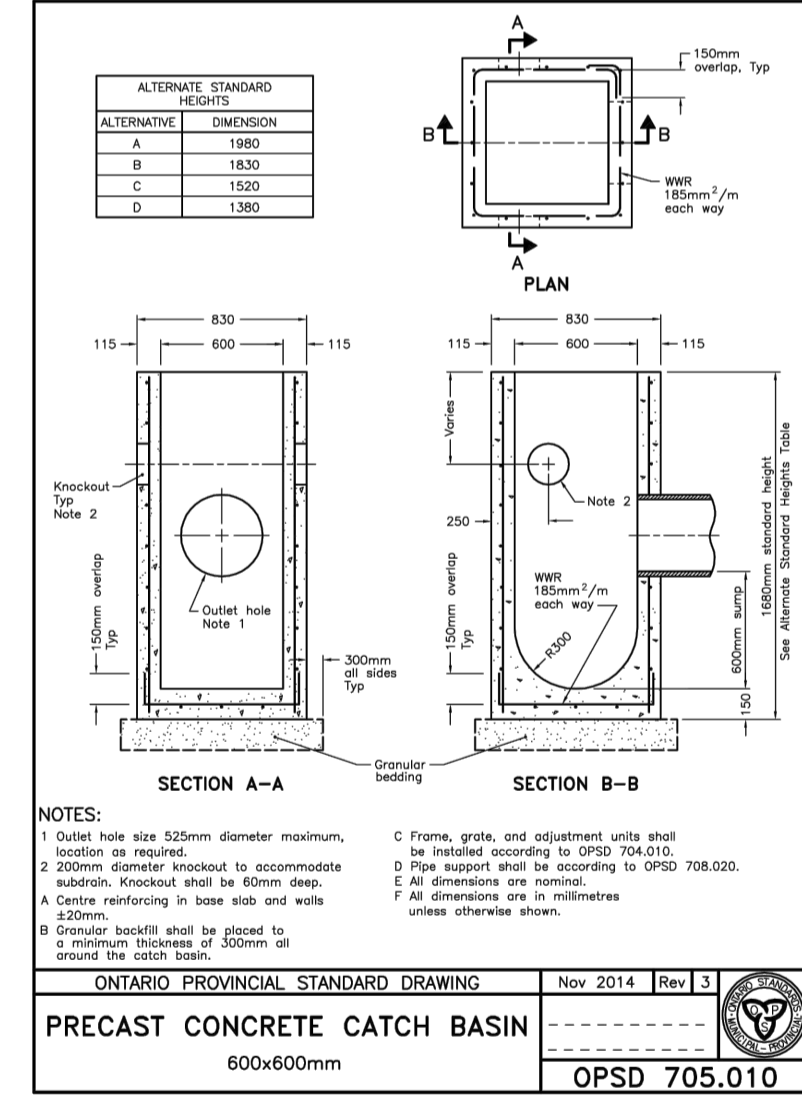
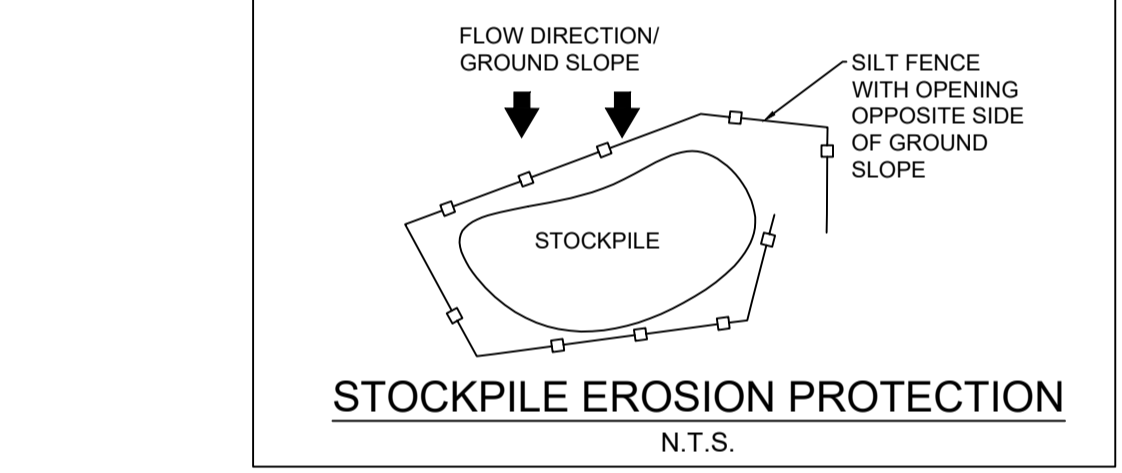
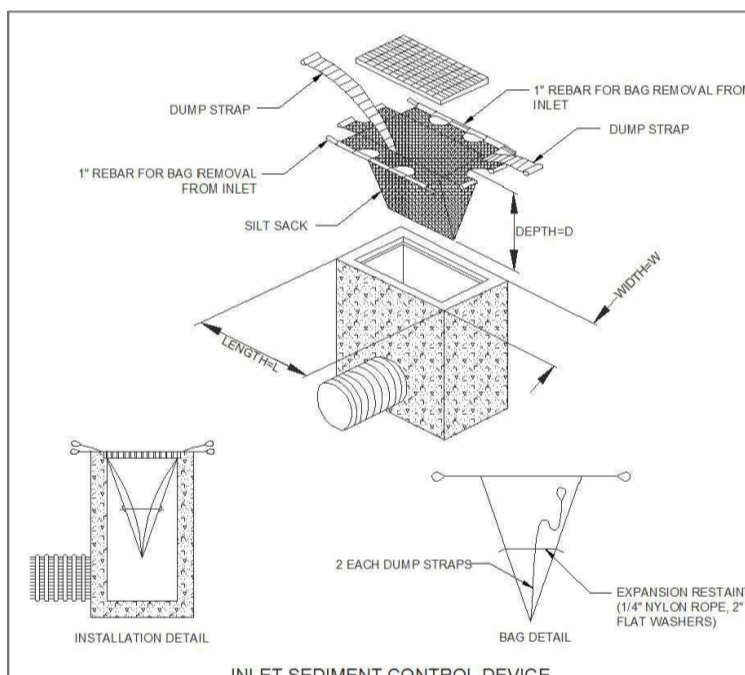
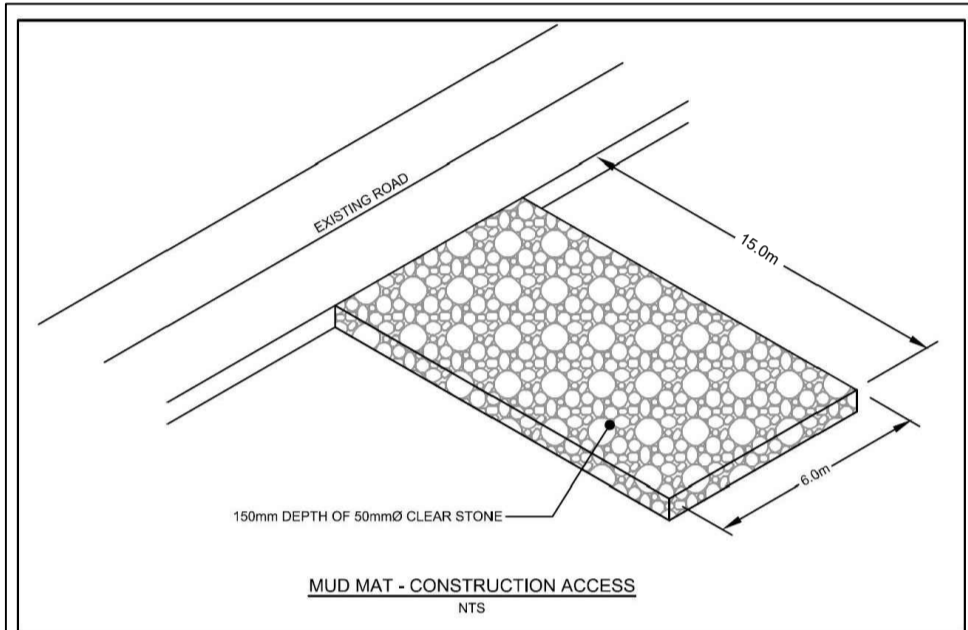
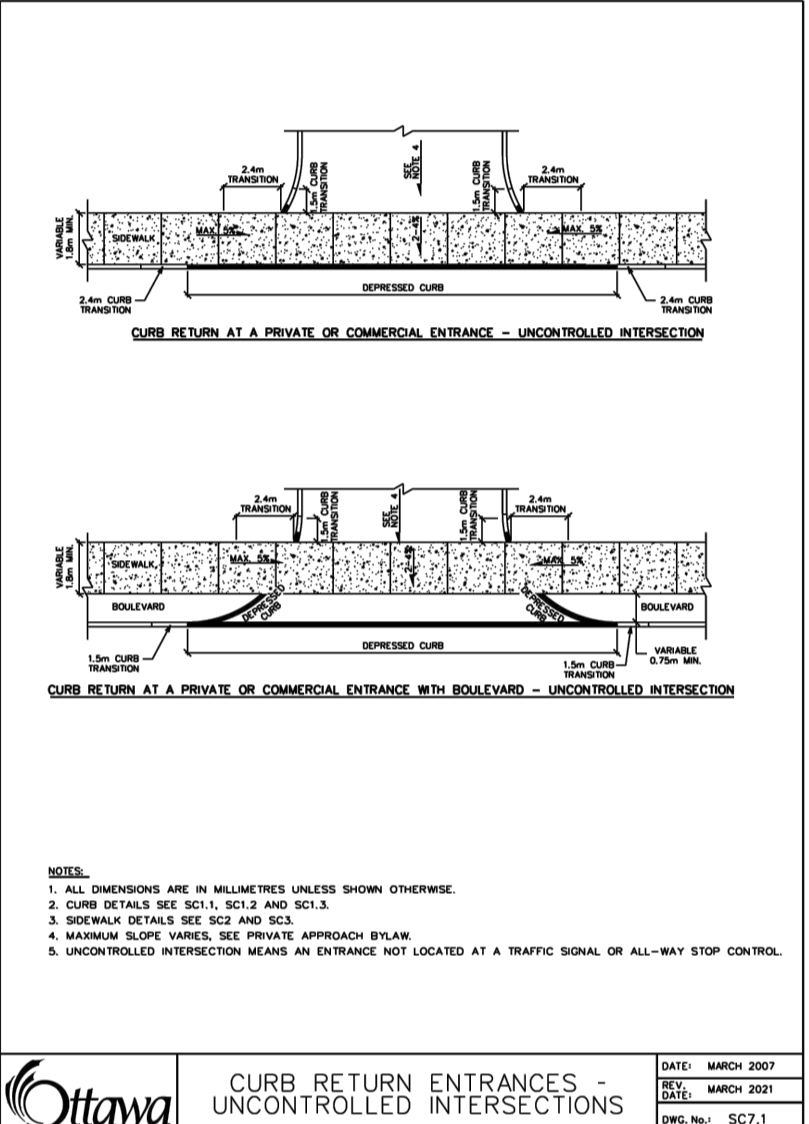
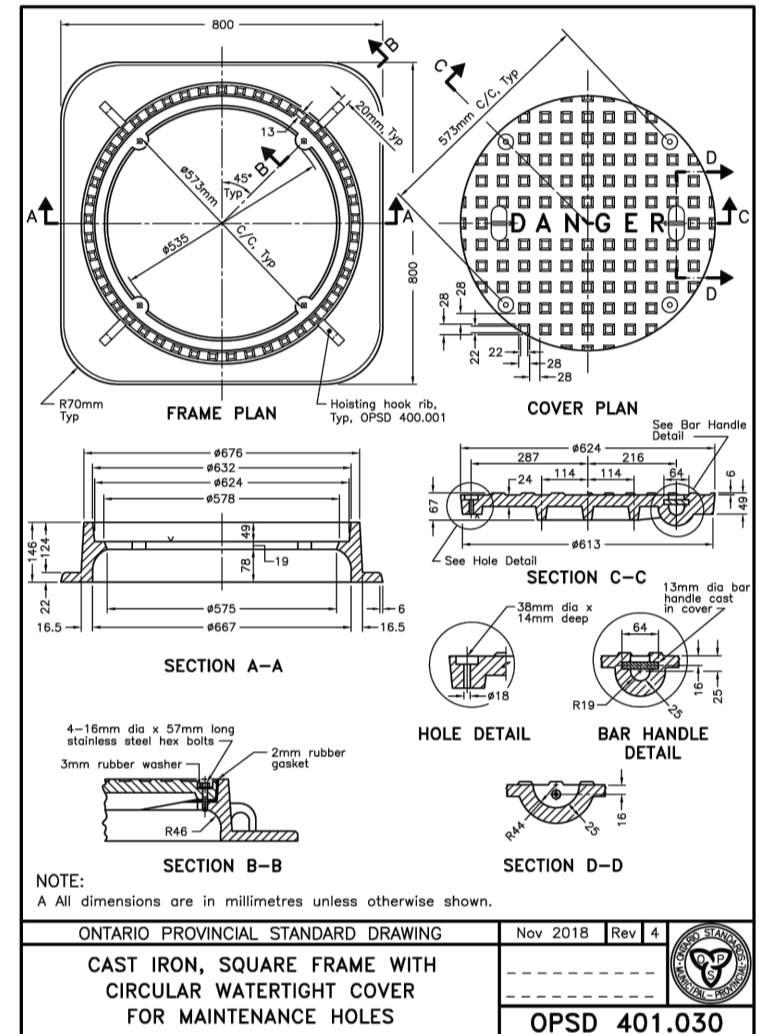
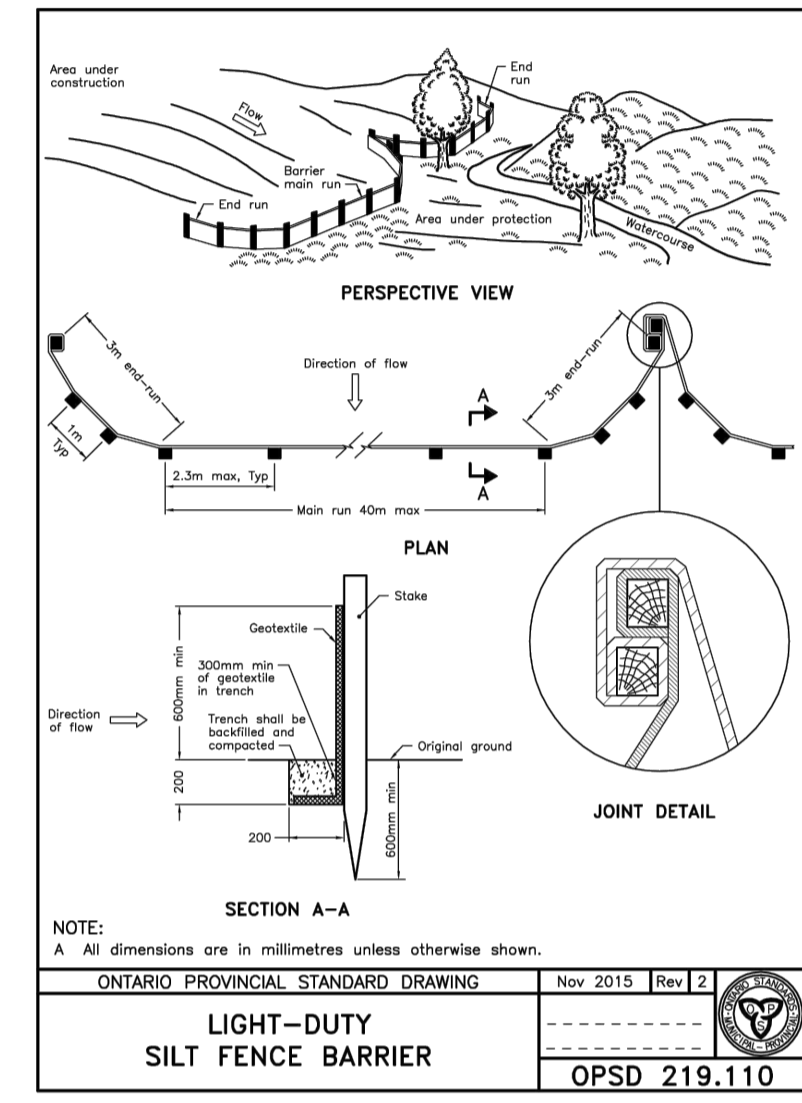
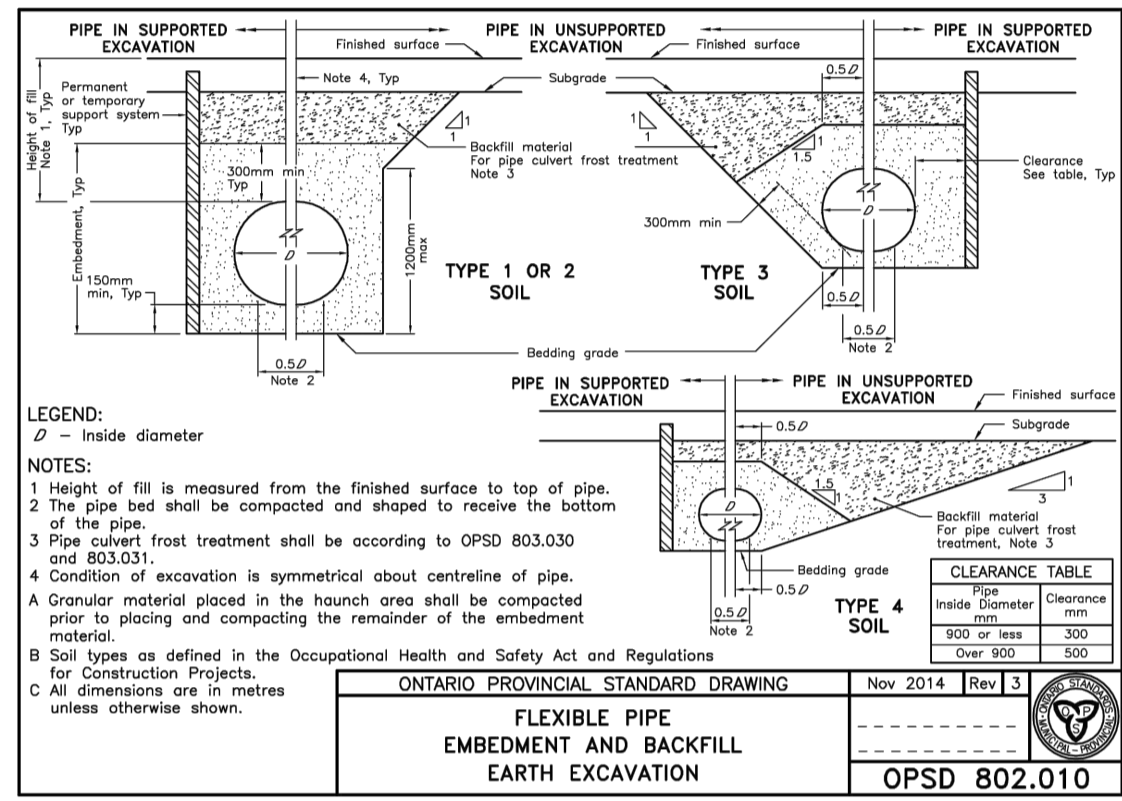
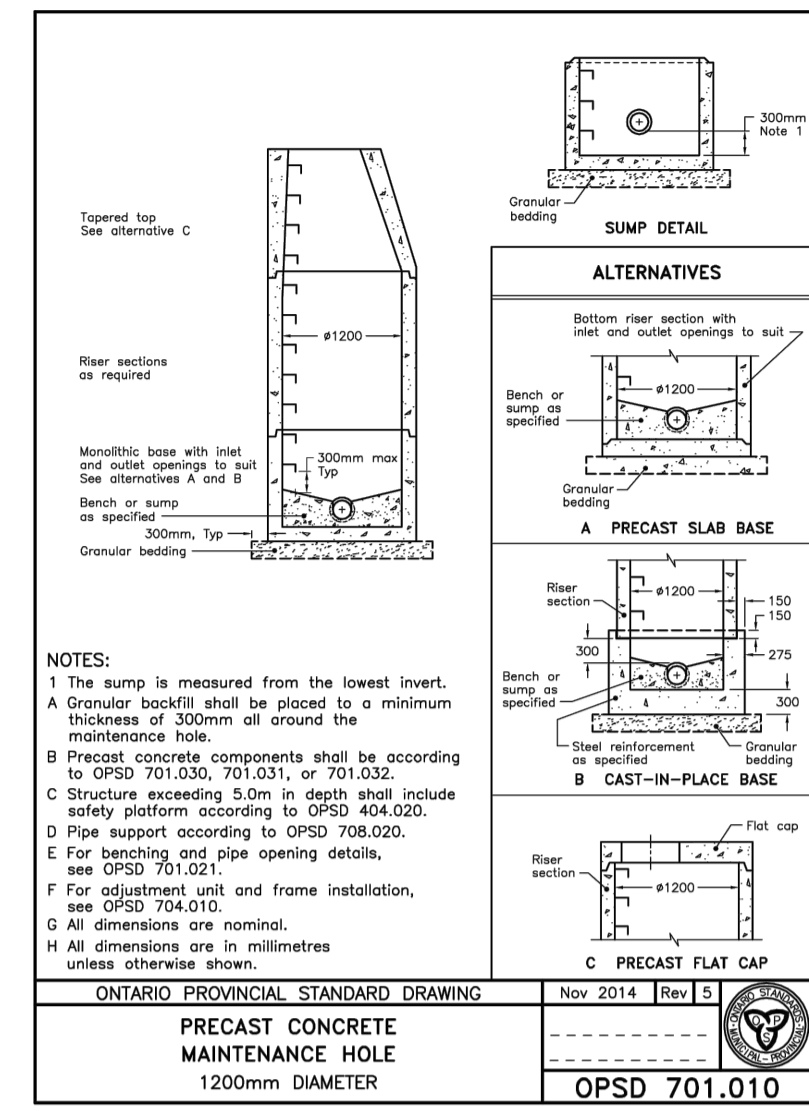
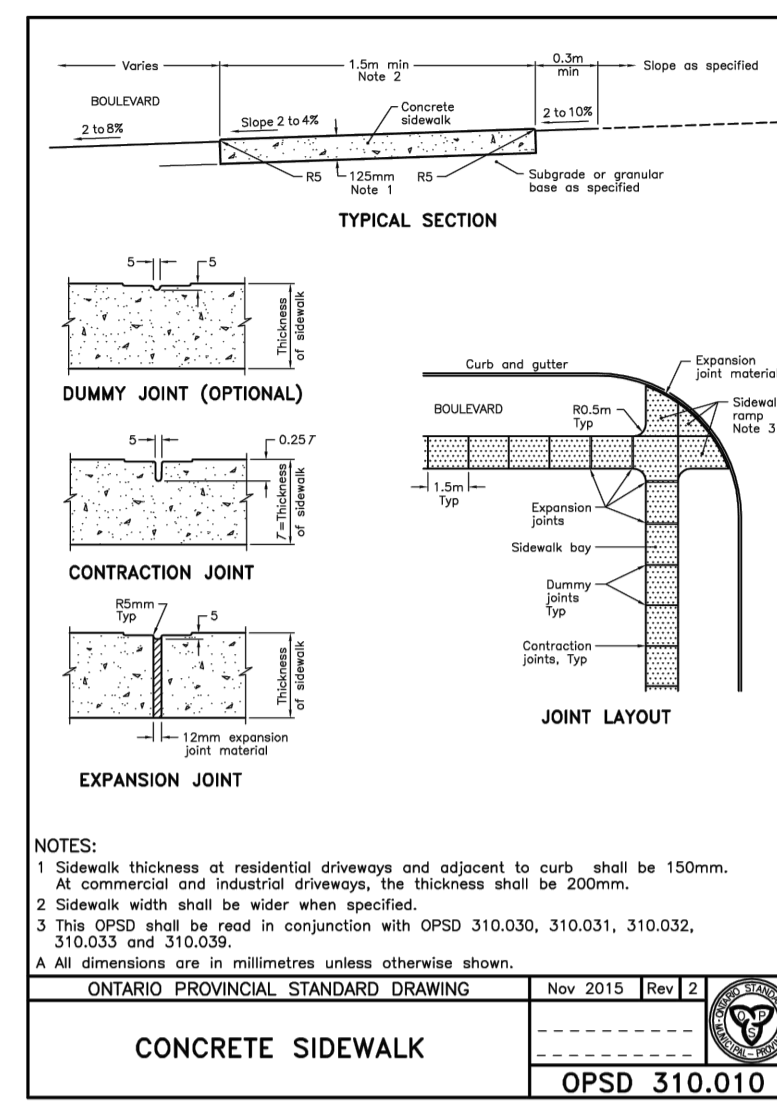
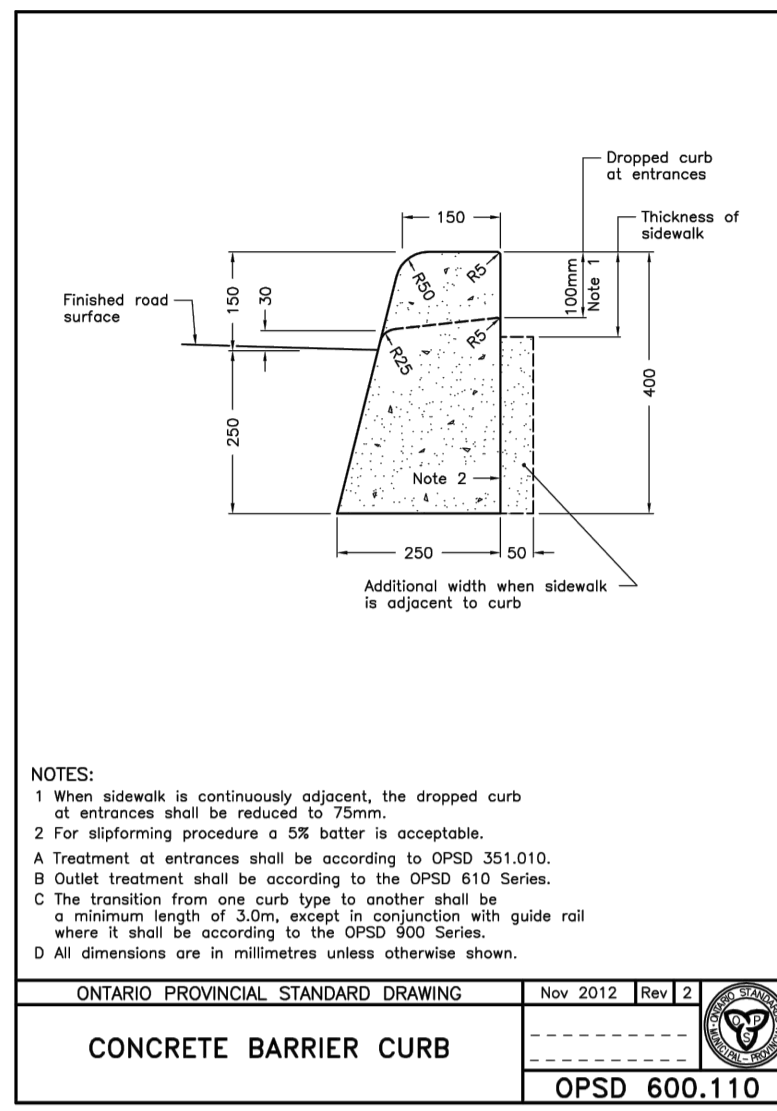
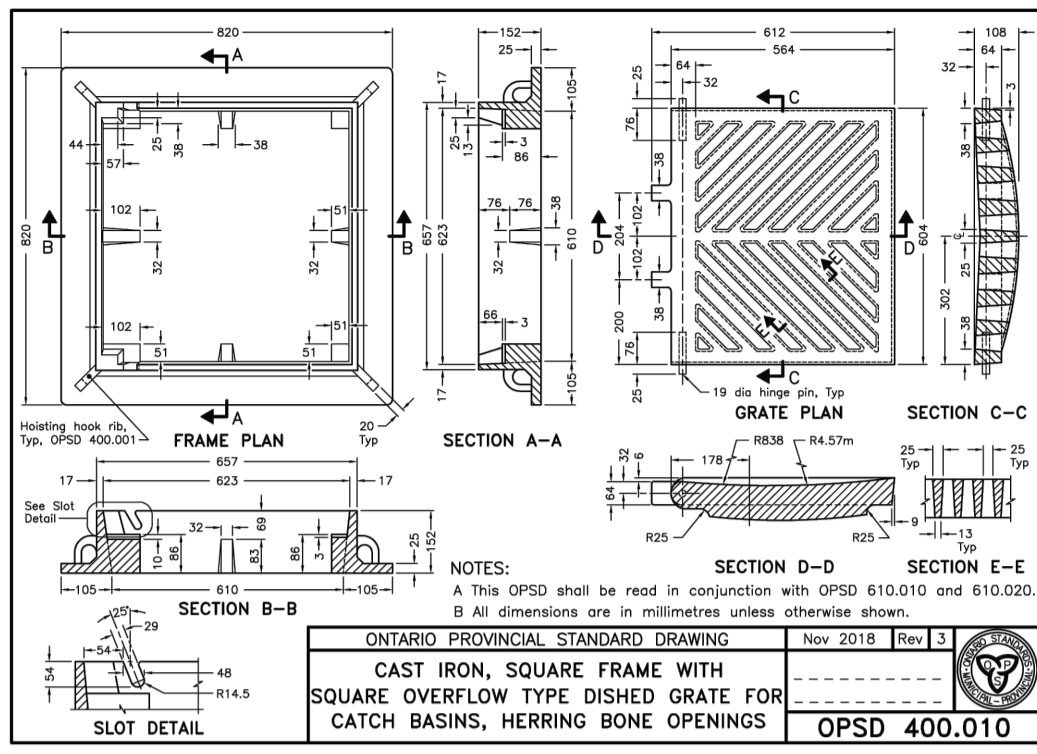
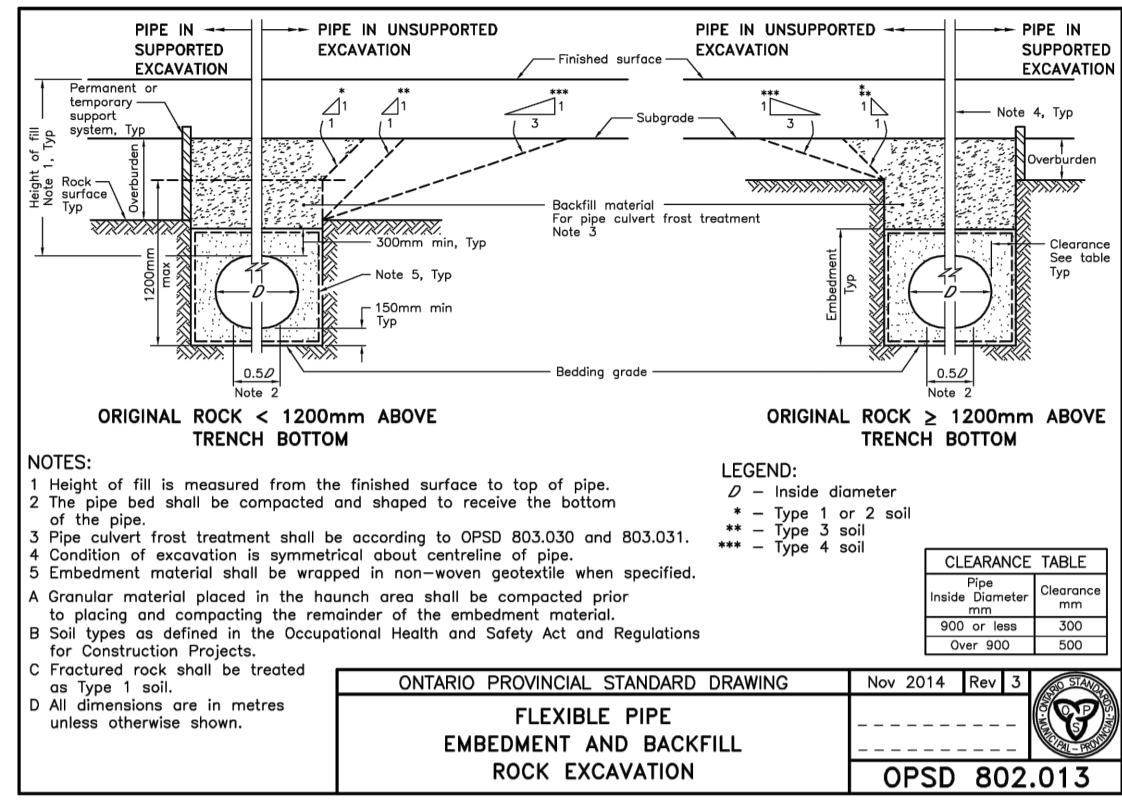

USE AND INTERPRETATION OF DRAWINGS

GENERAL CONDITIONS OF THE CONTRACT FOR CONSTRUCTION ARE PART OF THE CONTRACT DOCUMENTS AND DESCRIBE USE AND INTENT OF THE DRAWINGS. THE CONTRACT DOCUMENTS INCLUDE NOT ONLY THE DRAWINGS, BUT ALSO THE OWNER-CONTRACTOR AGREEMENTS, CONDITIONS OF THE CONTRACT, THE SPECIFICATIONS, ADDENDA, AND MODIFICATIONS ISSUED AFTER EXECUTION OF THE CONTRACT. THESE CONTRACT DOCUMENTS ARE COMPLEMENTARY, AND WHAT IS REQUIRED BY ANY ONE SHALL BE BINDING AS IF REQUIRED BY ALL. WORK NOT COMPLETELY DELINEATED HEREON SHALL BE CONSTRUCTED OF THE SAME MATERIALS AND DETAILED SIMILARLY AS WORK SHOWN MORE COMPLETELY ELSEWHERE IN THE CONTRACT DOCUMENTS.

BY USE OF THE DRAWINGS FOR CONSTRUCTION OF THE PROJECT, THE OWNER CONFIRMS THAT HE HAS REVIEWED AND APPROVED THE DRAWINGS. THE CONTRACTOR CONFIRMS THAT HE HAS VISITED THE SITE, FAMILIARIZED HIMSELF WITH THE LOCAL CONDITIONS, VERIFIED FIELD DIMENSIONS AND CORRELATED HIS OBSERVATIONS WITH THE REQUIREMENTS OF THE CONTRACT DOCUMENTS.

AS INSTRUMENTS OF SERVICE, ALL DRAWINGS, SPECIFICATIONS, CAD FILES OR OTHER ELECTRONIC MEDIA AND COPIES THEREOF FURNISHED BY THE ENGINEER ARE HIS PROPERTY. THEY ARE TO BE USED ONLY FOR THIS PROJECT AND ARE NOT TO BE USED ON ANY OTHER PROJECT, INCLUDING REPEATS OF THE PROJECT. CHANGES TO THE DRAWINGS MAY ONLY BE MADE BY THE ENGINEER.

UNLESS THE REVISION TITLE IS ISSUED FOR CONSTRUCTION, THESE DRAWINGS SHALL BE CONSIDERED PRELIMINARY AND SHALL NOT BE USED AS A CONSTRUCTION DOCUMENT.

THESE DRAWINGS ILLUSTRATE THE WORK TO BE DONE. THE ENGINEER IS NOT RESPONSIBLE FOR THE MEANS, METHODS, TECHNIQUES, SEQUENCES, AND PROCEDURES USED TO DO THE WORK, OR THE SAFETY ASPECTS OF CONSTRUCTION, AND NOTHING ON THESE DRAWINGS EXPRESSED OR IMPLIED CHANGES THIS CONDITION. CONTRACTOR SHALL DETERMINE ALL CONDITIONS AT THE SITE AND SHALL BE RESPONSIBLE FOR KNOWING HOW THEY AFFECT THE WORK. SUBMITTAL OF A BID TO PERFORM THIS WORK IS ACKNOWLEDGEMENT OF THE RESPONSIBILITIES, AND THAT THEY HAVE BEEN FULLY CONSIDERED IN PLANNING OF THE WORK, AND THE BID PRICE. NO CLAIMS FOR EXTRA CHARGES DUE TO THESE CONDITIONS WILL BE FORTCOMING.

UNAUTHORIZED CHANGES:
 IN THE EVENT THE CLIENT, THE CLIENT'S CONTRACTORS OR SUBCONTRACTORS, OR ANYONE FOR WHOM THE CLIENT IS LEGALLY LIABLE MAKES OR PERMITS TO BE MADE ANY CHANGES TO ANY REPORTS, PLANS, SPECIFICATIONS OR OTHER CONSTRUCTION DOCUMENTS PREPARED BY LRL ASSOCIATES LTD. (LRL) WITHOUT OBTAINING LRL'S PRIOR WRITTEN CONSENT, THE CLIENT SHALL ASSUME FULL RESPONSIBILITY FOR THE RESULTS OF SUCH CHANGES. THEREFORE THE CLIENT AGREES TO WAIVE ANY CLAIM AGAINST LRL AND TO RELEASE LRL FROM ANY LIABILITY ARISING DIRECTLY OR INDIRECTLY FROM SUCH UNAUTHORIZED CHANGES.

IN ADDITION, THE CLIENT AGREES, TO THE FULLEST EXTENT PERMITTED BY LAW, TO INDEMNIFY AND HOLD HARMLESS LRL FROM ANY DAMAGES, LIABILITIES OR COSTS, INCLUDING REASONABLE ATTORNEY'S FEES AND COST OF DEFENSE, ARISING FROM SUCH CHANGES.

IN ADDITION, THE CLIENT AGREES TO INCLUDE IN ANY CONTRACTS FOR CONSTRUCTION APPROPRIATE LANGUAGE THAT PROHIBITS THE CONTRACTOR OR ANY SUBCONTRACTORS OF ANY TIER FROM MAKING ANY CHANGES OR MODIFICATIONS TO LRL'S CONSTRUCTION DOCUMENTS WITHOUT THE PRIOR WRITTEN APPROVAL OF LRL AND THAT FURTHER REQUIRES THE CONTRACTOR TO INDEMNIFY BOTH LRL AND THE CLIENT FROM ANY LIABILITY OR COST ARISING FROM SUCH CHANGES MADE WITHOUT SUCH PROPER AUTHORIZATION.

GENERAL NOTES:
 EXISTING SERVICES AND UTILITIES SHOWN ON THESE DRAWINGS ARE TAKEN FROM THE BEST AVAILABLE RECORDS, BUT MAY NOT BE COMPLETE OR TO DATE. CONTRACTOR SHALL VERIFY LOCATION AND DEPTH OF PIPES AND CHECK WITH THE UTILITY COMPANIES BEFORE DIGGING OR PERFORMING WORK.

CONTRACTOR IS ADVISED TO COLLECT INFORMATION ON SOIL CONDITIONS BEFORE START OF CONSTRUCTION.

THE ENGINEER WAIVES ANY AND ALL RESPONSIBILITY AND LIABILITY FOR PROBLEMS WHICH ARISE FROM FAILURE TO FOLLOW THESE PLANS, SPECIFICATIONS AND THE INTENT THEREOF. THE ENGINEER DOES NOT ASSUME ANY LIABILITY FOR ANY ERRORS, OMISSIONS, INCONSISTENCIES, AMBIGUITIES OR CONFLICTS WHICH ARE ALLEGED.

CONTRACTOR TO VERIFY ALL DIMENSIONS AND NOTIFY THE ENGINEER OF ANY DISCREPANCIES BEFORE WORK COMMENCES. DO NOT SCALE DRAWINGS.

No.	REVISIONS	BY	DATE
04	RE-ISSUED FOR APPROVAL	M.L.	MAR 04 2024
03	RE-ISSUED FOR APPROVAL	M.L.	FEB 15 2024
02	RE-ISSUED FOR APPROVAL	M.L.	NOV 13 2023
01	ISSUED FOR APPROVAL	M.L.	JUNE 16 2023



NOT AUTHENTIC UNLESS SIGNED AND DATED

LRL
 ENGINEERING | INGENIERIE
 5430 Canotek Road | Ottawa, ON, K1J 9G2
 www.lrl.ca | (613) 842-3434

CLIENT: **HALO CAR WASH**

DESIGNED BY: M.L. DRAWN BY: M.L. APPROVED BY: M.B.

PROJECT: **PROPOSED DEVELOPMENT HALO CAR WASH 3095 PALLADIUM DRIVE KANATA, ON**

DRAWING TITLE: **CONSTRUCTION DETAIL PLAN**

PROJECT NO: 230273
 DATE: MAY 2023
C901