

Engineering

Land/Site
Development

Municipal
Infrastructure

Environmental/
Water Resources

Traffic/
Transportation

Recreational

Planning

Land/Site
Development

Planning Application
Management

Municipal Planning

Urban Design

Expert Witness
(LPAT)

Wireless Industry

Landscape Architecture

Streetscapes &
Public Amenities

Open Space, Parks &
Recreation

Community &
Residential

Commercial &
Institutional

Environmental
Restoration



PROPOSED PARKING LOT EXPANSION 600 MARCH ROAD

Stormwater Management Report

STORMWATER MANAGEMENT REPORT

NOKIA PARKING LOT EXPANSION 600 MARCH ROAD

Prepared by:

NOVATECH
Suite 200, 240 Michael Cowpland Drive
Kanata, Ontario
K2M 1P6

November 7, 2023
Revised: February 14, 2024

Ref: R-2023-143
Novatech File No. 121334

February 14, 2024

Nokia
600 March Road
Ottawa, Ontario
K2K 2T6

Attention: Margaret Wolodarski

**Re: Stormwater Management Report
NOKIA - Parking Lot Expansion
600 March Road, Ottawa, ON
Novatech File No.: 121334**

Enclosed is a copy of the revised 'Stormwater Management Report' for the proposed temporary parking lot expansion of the existing Nokia property at 600 March Road in the City of Ottawa. This report addresses the approach to storm drainage and stormwater management, and it is being submitted in support of a Site Plan Control Application.

Please contact the undersigned, should you have any questions or require additional information.

Yours truly,

NOVATECH



François Thauvette, P. Eng.
Senior Project Manager | Land Development & Public-Sector Engineering

cc: Jean-Miguel Roy (City of Ottawa)
Erik Cunnington (Colliers)

TABLE OF CONTENTS

1.0	INTRODUCTION	1
1.1	Location and Site Description	1
1.2	Pre-Consultation Information	1
1.3	Proposed Development.....	2
1.4	Reference Material.....	2
1.5	Storm Drainage and Stormwater Management.....	2
1.5.1	Stormwater Management Criteria and Objectives	3
1.5.2	Allowable Release Rate	3
1.5.3	Post-Development Conditions	4
1.5.3.1	Area A-1 – Controlled Flow from Main Parking Lot (Inc. OS-1 & OS-2).....	4
1.5.3.2	Area A-2 – Controlled Flow from South Parking Lot and SWM Pond.....	5
1.5.3.3	Summary of Post- Development Flows	6
1.5.3.4	Stormwater Quality Control.....	6
2.0	SITE GRADING	7
3.0	GEOTECHNICAL INVESTIGATIONS	7
4.0	EROSION AND SEDIMENT CONTROL	9
5.0	CONCLUSION	9

LIST OF FIGURES

Figure 1 Aerial Plan

LIST OF APPENDICES

Appendix A: Project Correspondence

Appendix B: Development Servicing Study Checklist

Appendix C: IDF Curves, SWM Calculations, Storm Sewer Design Sheet

Appendix D: Inlet Control Device (ICD) Information

Appendix E: Stormwater Quality Treatment Unit Information

Appendix F: Engineering Drawings

LIST OF PLANS

General Plan of Services (121334-GP)

Grading and Erosion and Sediment Control Plan (121334-GR)

Pre-Development Stormwater Drainage Plan (121334-STM)

Post-Development Stormwater Management Plan (121334-SWM)

1.0 INTRODUCTION

The Nokia Ottawa Office has recently severed their 10.453 ha property into two parcels; the retained property (5.183 ha), as outlined in RED in Figure 1 below, and the existing parking lots to the south, which will be re-developed as the new Nokia campus (5.270 ha, post road widening). As part of the proposed re-development, Nokia has retained Novatech to complete the site servicing, grading, and stormwater management design for the proposed parking lot expansion adjacent to their existing office building. Additional parking is required to meet the employees needs as the large existing parking lots to the south will be re-developed as part of the new Nokia campus. This report is being submitted in support of a Site Plan Control application for the proposed parking lot expansion only.

1.1 Location and Site Description

The subject site is located within the Kanata Research Park (KRP) and consists of the northern portion of the Nokia property located at 600 March Road. The area to be redeveloped around the existing building consists of drive aisles and small parking lots surrounded by landscaped areas. The site to be re-developed covers an approximate area of 2.298 hectares (of the total 5.183 ha) within the retained portion of the Nokia property. The subject site is generally surrounded by other commercial properties. The legal description of the subject site is designated as Block 6 and Part of Block 1 Registered Plan 4M-642 and Parts of Lot 9 Concession 4, Geographic Township of March, City of Ottawa.

Figure 1: Aerial view of the site



1.2 Pre-Consultation Information

A pre-consultation meeting was held with the City of Ottawa on April 21, 2023, at which time the client was advised of the general submission requirements. Subsequent meetings were held with City of Ottawa staff to further discuss the approach to storm drainage and stormwater management. Based on a review of **O. Reg. 525/98: Approval Exemptions**, a Ministry of the Environment, Conservation and Parks (MECP) Environmental Compliance Approval (ECA) is not anticipated to be required for the proposed parking lot expansion of an existing office building. Refer to **Appendix A** for a summary of the correspondence related to the proposed development.

1.3 Proposed Development

The proposed development is to expand the existing parking lot adjacent to the building to accommodate the parking needs of the Nokia employees. This is a direct result of the recent severance of the previously larger (10.453 ha) Nokia property, as the existing parking lots to the south will be re-developed as part of the new Nokia campus (to be filed under a separate SPC Application with the City of Ottawa). The proposed parking lot expansion is temporary, as the intent is to re-develop this property in the future to accommodate a large mixed-use development. The proposed parking lot will be serviced by the municipal storm sewer in Legget Drive. Where possible, existing trees and vegetation will be maintained on site, within the limits of the area to be re-developed.

1.4 Reference Material

The following design guidelines have been used to establish the stormwater management requirements for the proposed development:

- Ottawa Sewer Design Guidelines (2012) and Technical Bulletins (2010-present)
- Ministry of the Environment Design Guidelines for Sewage Works (2008)
- MOE Stormwater Management Planning and Design Manual (2003)
- Ontario Provincial Standards

The following reports, studies and guidelines were reviewed as part of the design process:

¹ KRP Stormwater Drainage Brief, prepared by Novatech in June 1987.

² Shirley's Brook and Watts Creek Subwatershed Study, prepared by Dillon Consulting Ltd. in 1999.

³ KRP Stormwater Management Plan (Report No. 93063, revised April 2000), prepared by Novatech in October 1999.

⁴ KRP Stormwater Drainage Brief, prepared by Novatech on December 11, 2000.

⁵ Geotechnical Investigation and Hydrogeological Assessment – 600 March Road, Kanata, Ontario (Project No.: 12566614), prepared by GHD on June 16, 2023.

1.5 Storm Drainage and Stormwater Management

Under current conditions, storm drainage from the area to be re-developed either sheet drains towards on-site catchbasins that flow through pipes located below the building and/or sheet drains uncontrolled towards Legget Drive. As described in the previous KRP SWM Reports^{1,3,4}, stormwater quality control measures are currently being provided by the downstream stormwater management facilities (SWMF) located just west of Shirley's Brook, on the 349 Terry Fox Drive property and on the 525 Legget Drive property behind the Brookstreet Hotel.

Under post-development conditions, the proposed parking lot will be serviced by a new on-site storm sewer system and new on-site SWM pond located near the southeast corner of the property. The storm sewer system will collect storm flows from the new parking lot and landscaped areas on the west and south sides of the building and direct them to the 375mm storm in Legget Drive. Site flows will be controlled prior to being directed to the municipal storm sewer. Due to the existing topography, runoff from a small portion of the landscaped boulevard along March Road will sheet drain onto the subject site and has been accounted for in the SWM design for the area to be re-developed. The new stormwater quality treatment unit will provide stormwater quality control measures for the subject site. In addition, the existing downstream SWMF will continue to

provide stormwater quality treatment for the subject site, other private properties as well as a portion of the Legget Drive and Terry Fox Drive municipal right-of-way. The approach for the stormwater management design for the subject site is discussed in the subsequent sections of the report.

1.5.1 Stormwater Management Criteria and Objectives

The stormwater management (SWM) criteria have been provided during pre-consultation meetings with the City of Ottawa. The SWM criteria and objectives are as follows and apply only to the portion of the site to be re-developed:

- Provide a dual drainage system (i.e., minor system and emergency overland flow route for events exceeding the 100-year design storm).
- Control post-development storm flows, up to an including the 100-year design event, to the maximum allowable release rate calculated using the Rational Method, with a runoff coefficient equivalent to existing conditions, but in no case greater than $C=0.5$, a time of concentration no less than 10 minutes and a 5-year rainfall intensity from City of Ottawa IDF curves.
- Ensure that a maximum of 0.35m of surface ponding will occur on the paved surfaces (i.e., private drive aisles or parking lots) during the 100-year storm event.
- Ensure that the surface ponding limits do not touch any part of the building envelope and remain below the lowest building opening during the stress test event (100-year + 20%).
- Target a stormwater quality control equivalent to an 'Enhanced' Level of Protection (i.e., minimum 80% TSS removal) for the portion of the site to be re-developed.
- Provide guidelines to ensure that site preparation and construction is in accordance with the current Best Management Practices for Erosion a Sediment Control.

No further stormwater management control measures are required for the portion of the site that remains unchanged.

Refer to **Appendix A** for correspondence from the City of Ottawa.

1.5.2 Allowable Release Rate

The allowable release rates from the 2.298 ha portion of the site to be re-developed and the two offsite tributary areas (OS-1 and OS-2), along the March Road boulevard, have been calculated using the Rational Method and are summarized in **Table 1**.

Table 1: Allowable Release Rates Summary Table

Description	C_{w5}	Time of Concentration (min)	Area (ha)	5-Yr Allowable Release Rate (L/s)
Portion of Site to be Redeveloped. (2.298 ha)	0.44	20	2.298	196.1
OS-1 (0.087 ha)	0.22	20	0.087	3.7
OS-2 (0.069 ha)	0.20	20	0.069	2.7
Total (2.454 ha)	0.42	-	2.454	202.5

Refer to **Appendix C** for detailed calculations.

1.5.3 Post-Development Conditions

Stormwater runoff from the portion of the site to be re-developed, including the paved parking lots, adjacent landscaped areas, and small SWMF near the southeast property corner, will be attenuated by inlet control devices (ICDs) installed within the new storm sewer system, prior to being directed to the municipal storm sewer in Legget Drive. Refer to the enclosed Post-Development Stormwater Management Plan (121334-SWM) for sub-catchment areas.

1.5.3.1 Area A-1 – Controlled Flow from Main Parking Lot (Including OS-1 & OS-2)

The post-development flow from this sub-catchment area will be attenuated by an ICD installed in the outlet pipe of STM MH 112. Stormwater runoff from this sub-catchment area will be temporarily stored underground within the storm sewer system and on the parking lot surface prior to being discharged into the downstream storm sewer system.

Table 1.1 summarizes the post-development design flow from this sub-catchment area as well as the ICD specifications, the anticipated ponding elevations, storage volumes required and storage volume provided for the 5-year and the 100-year design events.

Table 1.1: Stormwater Flows, ICD & Surface Storage

Design Event	Controlled Site Flows from Area A-1 (Incl. Areas OS-1 & OS-2)					
	ICD Type	Peak Flow	Ponding Elevation	~Average Flow (50% Qpeak)**	Storage Vol. Required*	Max Storage Available
2-Year	167mm dia. Orifice Plug Type ICD	98.2 L/s	81.17 m	49.1 L/s	152.4 m ³	1,009 m ³
5-Year		98.5 L/s	81.19 m	49.3 L/s	236.5 m ³	
100-Year		100.9 L/s	81.32 m	50.5 L/s	571.7 m ³	
100-Year+ 20%		102.0 L/s	81.38 m	51.0 L/s	725.5 m ³	

*Storage volumes are based on the 50% Qpeak flow rates, which generally represents the average flow.

**Represents rounded values.

Refer to **Appendix C** for detailed SWM calculations and to **Appendix D** for information related to the plug type ICD.

As indicated in the table above, this sub-catchment area will provide sufficient storage for the 2-year, 5-year and 100-year design events. Per City of Ottawa Design Guidelines, the site grading design will ensure that surface ponding depths will not touch the building envelope or lowest building openings during the 100-year+20% stress test. During larger storm events, stormwater within the paved lots will cascade towards (lower) downstream catchments areas and ultimately overflow towards Legget Drive, therefore generally maintaining existing drainage patterns.

Deviation from Ottawa Sewer Design Guidelines

The following outlines a deviation from the current Ottawa Sewer Design Guidelines (Technical Bulletin PIEDTB-2016-01 Section 8.3.11.1, first bullet), specifically related to no surface ponding allowed within the private parking lots and drive aisles during the 2-year storm event.

As discussed with City staff, several factors played a role in the design of the temporary parking lot, and thus the proposed on-site storm sewer system and SWM design:

- The shallow depth of the 375mm dia. (receiving) storm sewer in Legget Drive, limits the pipe size and slope of the proposed on-site storm sewer system, which in turn limits both the conveyance capacity of the system and thus potential storage available underground.
- The topography of the existing site and adjacent Right-of-Ways (i.e., >2.7m drop from March Road to Legget Drive), affects the grading of the proposed parking lot expansion and thus the layout of the catchbasins and storm sewer system, further limiting the potential storage available on the surface and more importantly underground.
- The length of the proposed on-site storm sewer required to drain the new parking lot starting from a shallow receiving sewer in Legget Drive, results in minimal cover on-site and the need for thermal insulation along most of the sewer pipe segments.
- Retrofitting an existing parking lot to meet current City standards, for which the original parking lot was not designed.
- Keeping in mind that this is a temporary parking lot, thus trying to keep construction costs to a minimum.

Considering the factors listed above, we concluded that temporary ‘nuisance’ surface ponding within the new parking lot during frequent (i.e., 2-year) rainstorm events is less of a concern than potentially surcharging the downstream municipal storm sewer system. As a result, we are intentionally over-controlling post-development flow as part of the on-site SWM design. Based on correspondence from the City, over-controlling site flows from the new parking lot should alleviate any negative impacts on the City’s municipal storm sewer system.

As a result, a deviation from the Ottawa Sewer Design Guidelines is being requested, specifically related to no surface ponding allowed within the private parking lots and drive aisles during the 2-year storm event.

1.5.3.2 Area A-2 – Controlled Flow from South Parking Lot and SWM Pond

The post-development flow from this sub-catchment area will be attenuated by an ICD installed in the outlet pipe of STM MH 116. Stormwater runoff from this sub-catchment area will be temporarily stored within the proposed dry pond prior to being discharged into the downstream storm sewer system then conveyed to the municipal storm sewer in Legget Drive.

Table 1.2 summarizes the post-development design flow from this sub-catchment area as well as the ICD specifications, the anticipated ponding elevations, storage volumes required and storage volume provided for the 2-year, 5-year and the 100-year design events.

Table 1.2: Stormwater Flows, ICD & Surface Storage

Design Event	Controlled Site Flows from Area A-1 (Pond)					
	ICD Type	Peak Flow	Ponding Elevation	~Average Flow (50% Qpeak)**	Storage Vol. Required*	Max Storage Available
2-Year	118mm dia.	20.4 L/s	78.76 m	10.2 L/s	87.3 m ³	406.3 m ³
5-Year	Orifice Plug	23.3 L/s	78.90 m	11.7 L/s	124.1 m ³	
100-Year	Type ICD	30.2 L/s	79.31 m	15.1 L/s	268.4 m ³	

*Storage volumes are based on the 50% Qpeak flow rates, which generally represents the average flow.

**Represents rounded values.

Refer to **Appendix C** for detailed SWM calculations and to **Appendix D** for information related to the plug type ICD.

As indicated in the table above, this sub-catchment area will provide sufficient storage for the 2-year, 5-year, 100-year, as well as the 100-year + 20% design events. During larger storm events, stormwater within the SWM pond would overflow towards the Legget Drive municipal Right-of-Way.

1.5.3.3 Summary of Post- Development Flows

Table 1.3 compares the post-development site flows from the proposed parking lot expansion area to the total uncontrolled pre-development flows (including flows from OS-1 & OS-2) and the maximum allowable release rate.

Table 1.3: Stormwater Flow Comparison Table

Design Event	Uncontrolled Flows (L/s)	Allowable Release Rate (L/s)	Drainage Areas A-1 to A-2 (Incl. OS-1 & OS-2)			
			Post-Development Conditions			
			A-1 (Incl. OS-1 & OS-2) Flow (L/s)	A-2 Flow (L/s)	Total Flow (L/s)	Reduction in Flow (L/s or %)*
2-Yr	150.0	202.5	98.2	20.4	118.6	31.4 or 21%
5-Yr	202.5		98.5	23.3	121.8	80.7 or 40%
100-Yr	399.7		100.9	30.2	131.1	268.6 or 67%

*Reduced flow compared to pre-development uncontrolled conditions.

As indicated above, the 2-year, 5-year and 100-year post-development flows will be over-controlled when compared to the allowable release rate specified by the City of Ottawa. Furthermore, this represents a significant reduction in total site flow rate when compared to the respective pre-development conditions for the portion of the site to be re-developed. Refer to **Appendix C** for detailed SWM calculations and to **Appendix D** for information related to the plug type ICDs. As indicated above, over-controlling the post-development site flows should alleviate any negative impacts the temporary parking lot will have on the City's municipal storm sewer system.

1.5.3.4 Stormwater Quality Control

Based on correspondence from the City of Ottawa, it is recommended that surface parking lots and drive aisles within the portion of the site to be re-developed meet an 'Enhanced' Level of Protection (i.e.: 80% TSS removal) as an appropriate water quality target. Landscaped areas are considered clean for the purposes of water quality and aquatic habitat protection.

To achieve this level of quality control protection, a new stormwater quality oil-grit separator treatment unit (CDS Model PMSU 3025-6) will be installed near the downstream end of the proposed storm sewer system, prior to directing flows into the municipal storm sewer in Legget Drive. Stormwater runoff collected by the on-site storm sewer system will be directed through the proposed treatment unit. The contributing area includes the proposed paved parking lot, and adjacent landscaped areas.

As stated above, the proposed oil-grit separator has been sized to provide an 'Enhanced' Level of water quality treatment prior to discharging the stormwater into the municipal storm sewer. Echelon Environmental and Contech Stormwater Solutions Inc. have modeled and analyzed the tributary area to provide a CDS unit capable of meeting the TSS removal requirements. The model parameters for the TSS removal were based on historical rainfall data for Ottawa from the Ontario Climate Centre. It was determined that a CDS Model PMSU 3025-6 will exceed the target removal rate, providing a net annual 80.3% TSS removal. The CDS unit has a treatment capacity of

approximately 68 L/s, a sediment storage capacity of 2,402m³; an oil storage capacity of 795 L and will treat a net annual volume of approximately 96.5% for the tributary area. The on-site catchbasins and storm manhole structures will be equipped with sumps to promote additional settling of sediment. As described in the previous KRP SWM Reports, additional water quality measures will also continue to be provided by the downstream stormwater management facility (SWMF) located just west of Shirley's Brook, on the 349 Terry Fox Drive property.

Maintenance and Monitoring of the Storm Sewer and Stormwater Management Systems

It is recommended that the client implement a maintenance and monitoring program for both the on-site storm sewers and the stormwater management systems: The storm drainage system should be inspected routinely (at least annually); the ICDs should be inspected to ensure they are free of debris; and the oil-grit separator (CDS unit) should be inspected at regular intervals and maintained when necessary to ensure optimum performance. Refer to **Appendix E** for the CDS unit design parameters, sizing analysis, operation, design, performance, and maintenance summary parameters as well as the annual TSS removal efficiency data.

When the subject site is redeveloped as future mixed-use lands, a full re-design of the on-site SWM system, including both quantity and quality control measures, will need to be implemented.

2.0 SITE GRADING

The topography of the existing site generally slopes from west to east. The existing grades drop by approximately 5.0m from west to east along Terry Fox Drive, while also dropping by 0.8m from north to south along March Road. Since the parking lot modifications are being proposed on the west and south sides of the existing building, the main challenge will be the 3.0m drop from west to east on the south side of the building.

The proposed grading design will need to tie into existing elevations around the perimeter of the site as well as around the existing building. The intent is to maintain as many of the existing trees as possible around the perimeter of the site, which have the best chance of surviving in the future, while accommodating the parking needs of the Nokia employees. Based on the proposed grading design, most of the existing landscaped berms located on the west side of the property will need to be flattened and the grade lowered to accommodate the proposed parking lot expansion. The western portion of the main parking lot will slope from west to east (i.e., maximum 3:1 terracing) to make up the grade difference, which means that surface ponding will only be possible closer to the building. The parking lot on the south side of the building will slope towards the proposed stormwater management pond located within the southeast corner of the property. Toe walls and high curbs are being proposed in certain areas in order to maintain and protect existing trees along the perimeter of the parking lot. The proposed toe walls and high curbs are to transition down into the barrier curb to ensure the adjacent landscape slopes are no steeper than 3:1. Due to the existing topography of the site, the emergency overflow route will continue to be towards Legget Drive. The proposed grading design will also ensure that the south property line is the high point to ensure no surface runoff is directed towards the severed lands to the south from the subject site. Refer to the enclosed Grading and ESC Plan (121334-GR) for details.

3.0 GEOTECHNICAL INVESTIGATIONS

GHD prepared a Geotechnical Investigation and Hydrogeological Assessment Report for the entirety of the 600 March Road property. Although much of the information is related to the new Nokia Campus development on the severed portion of the site, the report also includes information related to the proposed parking lot expansion. Bedrock encountered on-site was

found to be very shallow in certain areas, ranging from fair to excellent quality, and strong to very strong. General geotechnical recommendations related to the proposed parking lot expansion include the following:

Underground Site Services

As described in the Geotechnical Report⁵, underground service can either be founded on undisturbed native soils or on bedrock. It will be up to the geotechnical consultant to confirm the suitability of the foundation soils to provide adequate support for the buried services. Refer to section 5.10 of the Geotechnical Report⁵ for further recommendations related to the installation of underground services.

Pavement Design Recommendations

As described in the Geotechnical Report⁵, parking lots and drive aisles are expected to be constructed over native clay, glacial till, bedrock, and/or engineered fill. All unsuitable materials such as cover materials, surficial topsoil, and/or any other deleterious materials will need to be removed from the proposed paved areas. Existing fill material found below the anticipated parking lot subgrade levels may remain in place if proven to be competent, stable, and free of any organics and deleterious materials. It may also be possible to use reclaimed asphalt pavement (RAP) and/or reclaimed concrete material (RCM). Proposed pavement thicknesses have been taken directly from the Geotechnical Report⁵. To maintain the integrity of the pavement, filter-cloth wrapped perforated subdrains should be installed at all catch basins. Refer to section 5.11 of the Geotechnical Report⁵ for further pavement design recommendations and details.

Dewatering

Groundwater levels are generally dependant on seasonal conditions. As described in the Geotechnical Report⁵, according to O. Reg. 63/16 and O. Reg. 387/04, if the volume of water to be pumped from excavations for the purpose of construction dewatering is greater than 50,000 L/day a Permit to Take Water (PTTW) is required from the Ministry of the Environment, Conservation and Parks (MECP). According to O. Reg. 63.16, if short-term construction site dewatering is greater than 50,000 L/day but less than 400,000 L/day, registry with the Environmental Activity Sector Registry (EASR) is sufficient and a PTTW is not required. Based on the preliminary groundwater inflow estimates, water taking exceeding 400,000 L/day is not anticipated to be required. As a result, a PTTW will not be required for construction dewatering.

Excavations for service trenches may potentially extend below the groundwater level and some form of proactive dewatering is expected to be required. It is anticipated that conventional construction dewatering techniques should be adequate during construction, such as pumping from sumps.

Refer to the Geotechnical Report⁵, described in Section 1.4 of this report, for complete details related subsurface conditions, construction recommendations and geotechnical inspection requirements.

4.0 EROSION AND SEDIMENT CONTROL

To mitigate erosion and to prevent sediment from entering the storm sewer system and downstream ditches, temporary erosion and sediment control measures will be implemented on-site during construction in accordance with the Best Management Practices for Erosion and Sediment Control. This includes the following temporary measures:

- Filter bags will be placed under the grates of nearby catchbasins, manholes and will remain in place until vegetation has been established and construction is completed.
- Silt fencing will be placed per OPSS 577 and OPSD 219.110 along the surrounding construction limits.
- Mud mats will be installed at the site entrance.
- Street sweeping and cleaning will be performed, as required, to suppress dust and to provide safe and clean roadways adjacent to the construction site.
- On-site dewatering is to be directed to a sediment trap and/or gravel splash pad and discharged safely to an approved outlet as directed by the engineer.

The temporary erosion and sediment control measures will be implemented prior to construction and will remain in place during all phases of construction. Regular inspection and maintenance of the erosion control measures will be undertaken.

Refer to Section 3.0 above for further details related to anticipated site dewatering.

5.0 CONCLUSION

This report has been prepared in support of a Site Plan Control application for the proposed temporary parking lot expansion at 600 March Road. The conclusions are as follows:

- The proposed stormwater design (i.e., stormwater quantity control measures), will ultimately reduce peak flows into the municipal sewer in Legget Drive.
 - Post-development flow from sub-catchment area A-1, and A-2 will be controlled by inlet control devices (ICDs) installed within the on-site storm sewer system.
 - The total post-development flow from the subject site will be approximately 118.6 L/s during the 2-year event, 121.8 L/s during the 5-year event and 131.1 L/s during the 100-year event, over-controlled when compared to the allowable release rate (202.5 L/s) specified by the City of Ottawa. The post-development conditions also represent a significant reduction when compared to the respective pre-development conditions.
 - Over-controlling the post-development site flows should alleviate any negative impacts the temporary parking lot will have on the City's municipal storm sewer system.
 - Stormwater quality control measures will be provided by the new CDS unit installed near the downstream end of the proposed storm sewer system. Additional water quality measures will also continue to be provided by the downstream stormwater management facility (SWMF) located just west of Shirley's Brook, on the 349 Terry Fox Drive property.
 - Regular inspection and maintenance of the storm sewer system, including the inlet control devices, CDS unit and SWM pond is recommended to ensure that the storm drainage system is clean and operational.

- Erosion and sediment controls will be provided both during construction and on a permanent basis.

It is recommended that the proposed site servicing and stormwater management design be approved for implementation.

NOVATECH

Prepared by:



Chris Visser
Project Coordinator - Land Development

Reviewed by:



François Thauvette, P. Eng.
Senior Project Manager - Land Development

APPENDIX A
Project Correspondence

Pre-Application Consultation Site Plan Control

570 March Road

Meeting Date: 2023.04.21

Owner: Nokia Canada Inc.
Applicant: Colliers Strategy & Consulting

Ward: 4 – Kanata North
Councillor: Cathy Curry

Proposal Summary: Once construction on the new Nokia campus starts, the existing campus will lose the majority of its parking. Nokia's Network Infrastructure Business still needs to continue to operate from the existing campus until they move to the new campus in October 2027. The purpose of the Site Plan Application is to add additional parking stalls to the existing campus lands to accommodate employees parking needs.

Attendees: Internal
Krishon Walker, Planner
Julie Candow, Infrastructure Project Manager
Nancy Young, Planning Forester

External
Aaron Clodd, Colliers
Greg Winters, Novatech
James Ireland, Novatech
Francois Thauvette, Novatech
Ryan James, Novatech

Meeting Notes

Planning Comments (Provided by Krishon Walker)

- The site is located within the City's Suburban Transect as outlined on Schedule A – Transect Policy Areas of the Official Plan, is designated Kanata North Economic District on Schedule B5 – Suburban (West) Transect of the Official Plan (the Plan) and is along the March Road Mainstreet Corridor. The Kanata North Economic District is one of two Special Economic Districts identified in the Plan and is intended to support the City's economic development and growth.
- The site is currently zoned as Mixed-Use Centre Zone, Urban Exception 2816, Holding Provision (MC[2816]-h). Please ensure that your proposal complies with all applicable provisions under the Zoning By-law (specifically Part 4 of the Zoning By-law).

Feel free to contact Krishon Walker at Krishon.Walker@ottawa.ca for follow-up questions.

Engineering Comments (Provided by Julie Candow)

Please note the following information regarding the engineering design submission for the above noted site:

- The Stormwater Management Criteria, for the subject site, is to be based on the following:
 - a. Please refer to following background reports:
 - a. Shirley's Brook and Watts Creek Subwatershed Study, prepared by Dillon Consulting Ltd., 1999
 - b. Kanata Research Park, Storm Water Management Report, prepared by Novatech, dated June 1987

- c. Stormwater Management Plan, Kanata Research Park, City of Kanata, prepared by Novatech, dated April 2000
- d. Kanata Research Park Subdivision Design Brief, prepared by Novatech, dated August 2000

The stormwater management criteria shall be in accordance with the minor and major system storm allocations presented in the above mentioned reports.

- b. If the capacity of the receiving storm sewer is in question, over-controlling may be required, in which case flows to the storm sewer in excess of the 5-year storm release rate, up to and including the 100-year storm event, must be detained on site. In such a case the pre-development condition will be determined using the smaller of a runoff coefficient of 0.5 or the actual existing site runoff coefficient.
- c. The stormwater management area for the site can be limited to the area of the site that is to be redeveloped. The area's of the site that are to remain in existing conditions do not require further stormwater management.
- d. An enhanced level of water quality treatment (80% TSS Removal) is required for the portion of the site that is to be redeveloped.
- e. The treatment level in the north cell of stormwater management pond in SWM Facility No. 1 should be confirmed. Otherwise, stormwater quality control shall be achieved onsite.
- f. Please provide within the SWM Report the legal agreements related to the private SWM Facility No. 1 outlet located to the east on KRP lands.

Feel free to contact Julie Candow at Julie.Candow@ottawa.ca for follow-up questions.

Forestry Comments (Provided by Nancy Young)

- Section 4.8.2 of the New Official Plan provides strong direction to maintain the urban forest canopy and its ecosystem services during intensification noting when considering the impacts on individual trees, planning and development decisions, including Committee of Adjustment decisions, shall give priority to the retention and protection of large, healthy trees over replacement plantings and compensation. Applications must address the cumulative impacts on the urban forest, over time and space, with the goal of 40% urban forest canopy cover in mind. Further, that the City and the Committee of Adjustment may refuse a development application where it deems the loss of a tree(s) avoidable.
- The City has adopted a suite of High Performance Development Standards to improve the climate change resiliency of new developments. While these are not yet being fully implemented, it is recommended to provide the following details on the Landscape Plan:
 - For parking lots, provide 1 new tree for every 5 parking spaces to help cool the landscape of the site.
 - Confirm sufficient Soil volumes to support canopy cover on site (30m³ for street trees)
 - Proposed species must not include invasive species and target a minimum of 50% native species
- A TCR is required for this proposal, with the proposed parking locations overlaid on the tree layer, to assess and design around major tree impacts.
 - The TCR should also include an approximation of the anticipated road widening and concept site plans if available

- The TCR will be used to identify specific trees and groupings of trees that are a high priority for retention, and those that are more likely retainable through both the parking and building design.
- Trees along the March, Terry Fox, and Legget frontages are the highest priority to retain as screening for the site, through both stages of development.
- Parking (especially temporary) is not generally an acceptable reason to remove protected trees. All options to reduce the number of temporary parking spaces must be considered (e.g. leasing space in existing parking lots, transit, shuttles, working from home, etc).
- As discussed in the meeting, while a Landscape Plan is generally required for each site plan, given the temporary nature of this situation, I think we will need to make a modified arrangement. If there are any areas of tree retention that could be bolstered with planting at this stage, we can look at that, but I don't think it is in anyone's best interest to plant temporary trees unless they could be transplanted later. The Landscape Plan for the eventual build will need to address all planting for the site, working toward the 40% canopy cover target from the Official Plan.

TCR requirements:

- The TCR must list all trees on site, as well as off-site trees if the CRZ extends into the developed area, by species, diameter and health condition.
 - a. Please identify trees by ownership – private onsite, private on adjoining site, city owned, co-owned (trees on a property line)
- If trees are to be removed, the TCR must clearly show where they are, and document the reason they cannot be retained.
- All retained trees must be shown, and all retained trees within the area impacted by the development process must be protected as per City guidelines available at [Tree Protection Specification](#) or by searching Ottawa.ca.
- The location of tree protection fencing must be shown on the plan.
- The City encourages the retention of healthy trees; if possible, please seek opportunities for retention of trees that will contribute to the design/function of the site.

LP tree planting requirements:

- The Official Plan requires that "On urban properties subject to site plan control or community planning permits, development shall create tree planting areas within the site and in the adjacent boulevard, as applicable, that meet the soil volume requirements in any applicable City standards or best management practices or in accordance with the recommendation of a Landscape Architect;"
- Minimum Setbacks
 - Maintain 1.5m from sidewalk or MUP/cycle track or water service laterals.
 - Maintain 2.5m from curb
 - Coniferous species require a minimum 4.5m setback from curb, sidewalk or MUP/cycle track/pathway.

- Maintain 7.5m between large growing trees, and 4m between small growing trees. Park or open space planting should consider 10m spacing, except where otherwise approved in naturalization / afforestation areas.
- Adhere to Ottawa Hydro's planting guidelines (species and setbacks) when planting around overhead primary conductors.
- Tree specifications
 - Minimum stock size: 50mm tree caliper for deciduous, 200cm height for coniferous.
 - Maximize the use of large deciduous species wherever possible to maximize future canopy coverage
 - Tree planting on city property shall be in accordance with the City of Ottawa's Tree Planting Specification; and include watering and warranty as described in the specification (can be provided by Forestry Services).
 - Plant native trees whenever possible
 - No root barriers, dead-man anchor systems, or planters are permitted.
 - No tree stakes unless necessary (and only 1 on the prevailing winds side of the tree)
- Hard surface planting
 - Curb style planter is highly recommended
 - No grates are to be used and if guards are required, City of Ottawa standard (which can be provided) shall be used.
 - Trees are to be planted at grade
- Soil Volume
 - Please document on the LP that adequate soil volumes can be met:

Tree Type/Size	Single Tree Soil Volume (m3)	Multiple Tree Soil Volume (m3/tree)
Ornamental	15	9
Columnar	15	9
Small	20	12
Medium	25	15
Large	30	18
Conifer	25	15

- Sensitive Marine Clay
 - Please follow the City's 2017 Tree Planting in Sensitive Marine Clay guidelines
- Tree Canopy
 - The landscape plan shall show how the proposed tree planting will replace and increase canopy cover on the site over time, to support the City's 40% urban forest canopy cover target.
- At a site level, efforts shall be made to provide as much canopy cover as possible, through tree planting and tree retention, with an aim of 40% canopy cover at 40 years, as appropriate. Indicate on the plan the projected future canopy cover at 40 years for the site.

Feel free to contact Nancy Young at Nancy.Young@ottawa.ca for follow-up questions.

Application Submission Information

Application Type: **Standard Non Rural**

Site plan control application approval timelines vary based on the development complexity, scale, the quality of the submission and public consultation process if applicable. The legislated timeline under the Planning Act is 60 days. For more information on standard processing timelines, please visit: <https://ottawa.ca/en/city-hall/planning-and-development/information-developers/development-application-review-process/development-application-submission/development-application-forms#site-plan-control>

Prior to submitting a formal application, it is recommended that you pre-consult with the Ward Councillor, Cathy Curry.

For information on application fees, please visit: <https://ottawa.ca/en/city-hall/planning-and-development/information-developers/development-application-review-process/development-application-submission/fees-and-funding-programs/development-application-fees>

To request City of Ottawa plan(s) or report information please contact the City of Ottawa Information Centre: InformationCentre@ottawa.ca or (613) 580-2424 ext. 44455

Application Submission Requirements

For information on the preparation of Studies and Plans and the City's requirements, please visit: <https://ottawa.ca/en/city-hall/planning-and-development/information-developers/development-application-review-process/development-application-submission/guide-preparing-studies-and-plans>

Please provide electronic copies (PDF) of all plans and studies required. Hard copies are not required at this time.

Note that many of the plans and studies collected with this application must be signed, sealed and dated by a qualified engineer, architect, surveyor, planner or designated specialist.

APPLICANT'S STUDY AND PLAN IDENTIFICATION LIST

Legend: **S** indicates that the study or plan is required with application submission.

A indicates that the study or plan may be required to satisfy a condition of approval/draft approval.

For information and guidance on preparing required studies and plans refer [here](#):

S/A	ENGINEERING		S/A
S	1. Site Servicing Plan	2. Site Servicing Study / Assessment of Adequacy of Public Services	<input type="checkbox"/>
S	3. Grade Control and Drainage Plan	4. Geotechnical Study / Slope Stability Study	S
<input type="checkbox"/>	5. Composite Utility Plan	6. Groundwater Impact Study	<input type="checkbox"/>
<input type="checkbox"/>	7. Servicing Options Report	8. Wellhead Protection Study	<input type="checkbox"/>
<input type="checkbox"/>	9. Transportation Impact Assessment (TIA)	10. Erosion and Sediment Control Plan / Brief	S
S	11. Storm water Management Report / Brief	12. Hydro geological and Terrain Analysis	<input type="checkbox"/>
<input type="checkbox"/>	13. Hydraulic Water main Analysis	14. Noise / Vibration Study	<input type="checkbox"/>
<input type="checkbox"/>	15. Roadway Modification Functional Design	16. Confederation Line Proximity Study	<input type="checkbox"/>

S/A	PLANNING / DESIGN / SURVEY		S/A
<input type="checkbox"/>	17. Draft Plan of Subdivision	18. Plan Showing Layout of Parking Garage	<input type="checkbox"/>
<input type="checkbox"/>	19. Draft Plan of Condominium	20. Planning Rationale	S
S	21. Site Plan	22. Minimum Distance Separation (MDS)	<input type="checkbox"/>
<input type="checkbox"/>	23. Concept Plan Showing Proposed Land Uses and Landscaping	24. Agrology and Soil Capability Study	<input type="checkbox"/>
<input type="checkbox"/>	25. Concept Plan Showing Ultimate Use of Land	26. Cultural Heritage Impact Statement	<input type="checkbox"/>
S	27. Landscape Plan	28. Archaeological Resource Assessment Requirements: S (site plan) A (subdivision, condo)	<input type="checkbox"/>
S	29. Survey Plan	30. Shadow Analysis	<input type="checkbox"/>
<input type="checkbox"/>	31. Architectural Building Elevation Drawings (dimensioned)	32. Design Brief (includes the Design Review Panel Submission Requirements)	<input type="checkbox"/>
<input type="checkbox"/>	33. Wind Analysis		<input type="checkbox"/>

S/A	ENVIRONMENTAL		S/A
<input type="checkbox"/>	34. Phase 1 Environmental Site Assessment	35. Impact Assessment of Adjacent Waste Disposal/Former Landfill Site	<input type="checkbox"/>
<input type="checkbox"/>	36. Phase 2 Environmental Site Assessment (depends on the outcome of Phase 1)	37. Assessment of Landform Features	<input type="checkbox"/>
<input type="checkbox"/>	38. Record of Site Condition	39. Mineral Resource Impact Assessment	<input type="checkbox"/>
S	40. Tree Conservation Report	41. Environmental Impact Statement / Impact Assessment of Endangered Species	<input type="checkbox"/>
<input type="checkbox"/>	42. Mine Hazard Study / Abandoned Pit or Quarry Study	43. Integrated Environmental Review (Draft, as part of Planning Rationale)	S

S/A	ADDITIONAL REQUIREMENTS		S/A
S	44. Applicant's Public Consultation Strategy (may be provided as part of the Planning Rationale)	45. Site Lighting Plan	<input type="checkbox"/>
A	46. Site Lighting Certification Letter	47.	<input type="checkbox"/>

Meeting Date: 2023.04.21

Application Type: *Site Plan Control*

File Lead (Assigned Planner): Krishon Walker

Infrastructure Approvals Project Manager: Julie Candow

Site Address (Municipal Address): 570 March Road

Preliminary Assessment: 1 2 3 4 5

*One (1) indicates that considerable major revisions are required before a planning application is submitted, while five (5) suggests that proposal appears to meet the City's key land use policies and guidelines. **This assessment is purely advisory and does not consider technical aspects of the proposal or in any way guarantee application approval.**

It is important to note that the need for additional studies and plans may result during application review. If following the submission of your application, it is determined that material that is not identified in this checklist is required to achieve complete application status, in accordance with the Planning Act and Official Plan requirements, the Planning, Real Estate and Economic Development Department will notify you of outstanding material required within the required 30 day period. Mandatory pre-application consultation will not shorten the City's standard processing timelines, or guarantee that an application will be approved. It is intended to help educate and inform the applicant about submission requirements as well as municipal processes, policies, and key issues in advance of submitting a formal development application. This list is valid for one year following the meeting date. If the application is not submitted within this timeframe the applicant must again pre-consult with the Planning, Real Estate and Economic Development Department.

Francois Thauvette

From: Walker, Krishon <krishon.walker@ottawa.ca>
Sent: Thursday, October 12, 2023 4:23 PM
To: Cunningham, Erik
Cc: Ryan James; James Ireland; Francois Thauvette; Angela Taggart; kirby@kerryhill.ca; Surprenant, Eric; Young, Nancy
Subject: 600 March Road (Parking Lot Expansion)

Hi Erik,

Please see the notes from our meeting yesterday below:

Planning

I did not have an opportunity to mention this yesterday but Cash-In-Lieu of Conveyance of Parkland will be required in accordance with the Parkland Dedication [By-law No. 2022-280](#).

Engineering

- Nuisance ponding increases the risk of ICD being removed and in turn surcharging City system. Underground storage is to be looked at exhaustively in combination to dry pond proposed.
- Assessment of residual capacity of Leggett sewer system is to be carried out by Novatech with assessment of HGLs and impact on Leggett Sewer.
- Also, normally only one sewer connection is allowed per property.
- This would technically be deviations from our standards but we can work with consultant on these items.

As it relates to the Geotechnical study, if it looked at conditions here, that should be acceptable for pavement structure.

In addition to the material submitted, we will require the Stormwater management Study to be provided.

Feel free to contact Eric Surprenant for follow-up questions.

Forestry

TCR and General comments

- The Tree Conservation Plan has been provided with this submission. Slight modifications have been made to adjust the parking lot layout to retain a small number of trees along the March Rd frontage and additional trees adjacent to the existing building. Further information is required to assess the overall canopy cover impacts of this design (including tree planting opportunities), and whether further alterations could allow for the retention of more of the trees identified as a high priority on site.

- Section 4.8.2 of New Official Plan provides strong direction to maintain the urban forest canopy and its ecosystem services during intensification noting when considering the impacts on individual trees, planning and development decisions, including Committee of Adjustment decisions, shall give priority to the retention and protection of large, healthy trees over replacement plantings and compensation. Applications must address the cumulative impacts on the urban forest, over time and space, with the goal of 40% urban forest canopy cover in mind. Further, that the City and the Committee of Adjustment may refuse a development application where it deems the loss of a tree(s) avoidable. Site plan control applications must create tree planting areas within the site and in the adjacent boulevard, meeting the City's soil volume requirements and planting standards.
- Trees along the March, Terry Fox, and Legget frontages are the highest priority to retain as screening for the site, through all stages of development.
- Temporary uses (parking, staging, etc.) are not generally an acceptable reason to remove protected trees. Ensure that plans, including for construction use, account for the retention of as many existing trees as possible.
- Please continue to explore options to further reduce parking spaces or pull the parking closer to the building to allow for retention of more of those trees around the perimeter of the site with a reasonable chance of retention through the future site plan.
- The TCR must meet the requirements laid out in [Schedule E](#) of the Tree Protection By-law. Please provide further detail on the following within the TCR:
 - Canopy cover assessment and comparison
 - Confirmation that the proposed tree protection fencing location is measured as 10xdbh as a radius from the trunk of each tree
 - Mitigation recommendations where excavation is proposed within the CRZ of any protected tree
 - Installation of retaining/toe walls and parking islands in close proximity to protected trees without impacting tree stability or survival
 - Discussion of options considered to design parking to minimize tree impacts
 - A summary table of trees to be removed, retained and planted

Landscape Plan comments

- A Landscape Plan is required with this application. To support the City's urban forest canopy cover target, efforts shall be made to provide as much canopy cover as possible at a site level, through tree planting and tree retention. The Landscape Plan shall show how the proposed tree planting and retention will contribute to the City's overall canopy cover over time by doing a projection of the future canopy cover for the site to 40 years. The calculations for the canopy cover projection must be shown on the plan.
- Since our first meeting, the City has adopted the new [Landscape Plan Terms of Reference](#). Please ensure that the conceptual landscape plan addresses the high level aspects of these requirements (in particular, the section below, related to canopy cover projection). Future landscape plans must address all of the components within this document.

- The site plan is mostly hard surface. Along with the canopy cover targets, please demonstrate how urban heat islands will be addressed. Best Management Practices include provision of one tree for every 5 parking spaces within parking lot areas.
- The Official Plan designates March Rd as a Scenic Entry Route and provides direction to maintain or enhance the views from these roadways through provision of landscaping (including a double row of trees) as screening from parking lots and outdoor storage. The Landscape, Site plan and TCR will need to address how this landscape screening will be provided, accounting for retention of existing trees and any potential road widening.
- The Official Plan section 4.8.2, sub 3 provides the following direction related to tree planting related to site plans:
 - a) Preserve and provide space for mature, healthy trees on private and public property, including the provision of adequate volumes of high-quality soil as recommended by a Landscape Architect;
 - b) On urban properties subject to site plan control or community planning permits, development shall create tree planting areas within the site and in the adjacent boulevard, as applicable, that meet the soil volume requirements in any applicable City standards or best management practices or in accordance with the recommendation of a Landscape Architect;
- Understanding that most planting on this site will be temporary, prior to the development of the lot, the priority areas for tree planting are around the perimeter of the site, including the Right of Ways.
- The planting plan should prioritize large-growing native species to increase the canopy cover on site. Along the March Rd frontage, where screening is a high priority, conifers or trees with low, dense branching should be considered.
- Please document on the LP that adequate soil volumes can be met:

Tree Type/Size	Single Tree Soil Volume (m3)	Multiple Tree Soil Volume (m3/tree)
Ornamental	15	9
Columnar	15	9
Small	20	12
Medium	25	15
Large	30	18
Conifer	25	15

Feel free to contact Nancy Young for follow-up questions.

Let me know if you have any questions.

Best Regards,

Krishon Walker, MCIP, RPP, PMP

Planner II | Urbaniste II

Economic Development Services | Services de développement économique

Planning, Real Estate and Economic Development | Direction générale de la planification, de l'immobilier et du développement économique

City of Ottawa | Ville d'Ottawa
110 Laurier Avenue West / 110 avenue Laurier Ouest
Ottawa, Ontario, K1P 1J1
 613.580.2424 ext./poste 24161

My pronouns are he/him

This e-mail originates from the City of Ottawa e-mail system. Any distribution, use or copying of this e-mail or the information it contains by other than the intended recipient(s) is unauthorized. Thank you.

Le présent courriel a été expédié par le système de courriels de la Ville d'Ottawa. Toute distribution, utilisation ou reproduction du courriel ou des renseignements qui s'y trouvent par une personne autre que son destinataire prévu est interdite. Je vous remercie de votre collaboration.

Francois Thauvette

From: Surprenant, Eric <Eric.Surprenant@ottawa.ca>
Sent: Friday, October 13, 2023 10:09 AM
To: Francois Thauvette
Cc: Walker, Krishon; Cunnington, Erik; James Ireland; Greg Winters
Subject: Re: 600 March Road - Parking Lot Expansion (121334)

Hello François,

Thanks for reaching out. I can agree that for a temporary parking lot we can be flexible on a few fronts. Please ensure that your rational is well presented in the Stormwater Management study, the overcontrol of the site does address the concern and therefore we will not ask that you analyse the Leggett Sewer.

As for the more frequent ponding occurring in Nokia's "temporary" parking as I noted please also provide full rational in the Stormwater Management report.

Hopefully this addresses your concerns.

Let me know if you have any further questions.

Thanks,

Eric Surprenant, CET
Sr, Project Manager, Infrastructure Projects, West
Planning, Real Estate & Economic Development
613 580-2424 ext.: 27794

Absence Alert:

From: Francois Thauvette <f.thauvette@novatech-eng.com>
Sent: October 12, 2023 15:13
To: Surprenant, Eric <Eric.Surprenant@ottawa.ca>
Cc: Walker, Krishon <krishon.walker@ottawa.ca>; Cunnington, Erik <Erik.Cunnington@colliers.com>; James Ireland <j.ireland@novatech-eng.com>; Greg Winters <g.winters@novatech-eng.com>
Subject: RE: 600 March Road - Parking Lot Expansion (121334)

CAUTION: This email originated from an External Sender. Please do not click links or open attachments unless you recognize the source.

ATTENTION : Ce courriel provient d'un expéditeur externe. Ne cliquez sur aucun lien et n'ouvrez pas de pièce jointe, excepté si vous connaissez l'expéditeur.

Hi Eric,

In our Teams call yesterday, you mentioned that the City 'might' be looking for an analysis of the City's downstream storm sewer system. Unfortunately, you left before the end of the meeting, so we never finished the conversation. Is an analysis necessary if we intend to over-control post-development flows from the new temporary parking lot by approximately 74 L/s less than the allowable release rate specified by the City? We assume that since we are over-controlling post-development flows, there would be no negative impact on the City's sewer system. Based on the current design, the 100-year post-development peak storm flows will be controlled to approximately 128 L/s (based on the capacity of the on-site storm sewer) vs. a Q allowable of ~202 L/s. As discussed, we cannot upsize the on-site storm sewer nor can we increase its slope as the receiving sewer in Leggett Drive is a (shallow) 375mm dia. pipe and we are already struggling with cover.

An analysis of the municipal storm sewer system was never included in our scope of work as this is typically done by the City's SWM modelling group and we are significantly over-controlling post-development flows when compared to the allowable release rate specified by the City. If necessary, we assume the City's SWM modelling group could input our post-development flows into their model to analyse the downstream sewer system. We do not have the HGL information, nor do we have the storm drainage area plan for the municipal storm sewer system in this area. Please review and provide additional clarification (re: the analysis of the downstream storm sewer system) as part of the City's formal response.

Regards,

François Thauvette, P. Eng., Sr. Project Manager | Land Development & Public-Sector Engineering

NOVATECH

Engineers, Planners & Landscape Architects

240 Michael Cowpland Drive, Suite 200, Ottawa, ON, K2M 1P6 | T: 613.254.9643 Ext: 219 | C: 613.276.0310

The information contained in this email message is confidential and is for exclusive use of the addressee.

-----Original Appointment-----

From: Walker, Krishon <krishon.walker@ottawa.ca>

Sent: Tuesday, October 3, 2023 2:24 PM

To: Walker, Krishon; Cunnington, Erik; Ryan James; James Ireland; Francois Thauvette; Young, Nancy; Surprenant, Eric

Cc: Angela Taggart; kirby@kerryhill.ca

Subject: 600 March Road (Parking Lot Expansion)

When: Wednesday, October 11, 2023 1:45 PM-2:30 PM (UTC-05:00) Eastern Time (US & Canada).

Where: Microsoft Teams Meeting

Importance: High

Hello all,

I am pushing our meeting back by 15 minutes – we will meet from 1:45 pm to 2:30 pm. That should give us enough time to discuss submission package and next steps.

Best Regards,

Krishon Walker, MCIP, RPP, PMP

Planner II | Urbaniste II

Economic Development Services | Services de développement économique

Planning, Real Estate and Economic Development | Direction générale de la planification, de l'immobilier et du développement économique

City of Ottawa | Ville d'Ottawa

110 Laurier Avenue West / 110 avenue Laurier Ouest

Ottawa, Ontario, K1P 1J1

 613.580.2424 ext./poste 24161

My pronouns are he/him

Microsoft Teams meeting

Join on your computer, mobile app or room device

[Click here to join the meeting](#)

Meeting ID: 233 394 456 22

Passcode: Hr5n9K

[Download Teams](#) | [Join on the web](#)

Join with a video conferencing device

teams@vc.ottawa.ca

Video Conference ID: 117 869 330 9

[Alternate VTC instructions](#)

Or call in (audio only)

[+1 613-319-1080,,880618839#](#) Canada, Ottawa-Hull

Phone Conference ID: 880 618 839#

[Find a local number](#) | [Reset PIN](#)

[Learn More](#) | [Meeting options](#)

This e-mail originates from the City of Ottawa e-mail system. Any distribution, use or copying of this e-mail or the information it contains by other than the intended recipient(s) is unauthorized. Thank you.

Le présent courriel a été expédié par le système de courriels de la Ville d'Ottawa. Toute distribution, utilisation ou reproduction du courriel ou des renseignements qui s'y trouvent par une personne autre que son destinataire prévu est interdite. Je vous remercie de votre collaboration.

This e-mail originates from the City of Ottawa e-mail system. Any distribution, use or copying of this e-mail or the information it contains by other than the intended recipient(s) is unauthorized. Thank you.

Le présent courriel a été expédié par le système de courriels de la Ville d'Ottawa. Toute distribution, utilisation ou reproduction du courriel ou des renseignements qui s'y trouvent par une personne autre que son destinataire prévu est interdite. Je vous remercie de votre collaboration.

APPENDIX B

Development Servicing Study Checklist

Servicing study guidelines for development applications

4. Development Servicing Study Checklist

The following section describes the checklist of the required content of servicing studies. It is expected that the proponent will address each one of the following items for the study to be deemed complete and ready for review by City of Ottawa Infrastructure Approvals staff.

The level of required detail in the Servicing Study will increase depending on the type of application. For example, for Official Plan amendments and re-zoning applications, the main issues will be to determine the capacity requirements for the proposed change in land use and confirm this against the existing capacity constraint, and to define the solutions, phasing of works and the financing of works to address the capacity constraint. For subdivisions and site plans, the above will be required with additional detailed information supporting the servicing within the development boundary.

4.1 General Content

- Executive Summary (for larger reports only).
- Date and revision number of the report.
- Location map and plan showing municipal address, boundary, and layout of proposed development.
- Plan showing the site and location of all existing services.
- Development statistics, land use, density, adherence to zoning and official plan, and reference to applicable subwatershed and watershed plans that provide context to which individual developments must adhere.
- Summary of Pre-consultation Meetings with City and other approval agencies.
- Reference and confirm conformance to higher level studies and reports (Master Servicing Studies, Environmental Assessments, Community Design Plans), or in the case where it is not in conformance, the proponent must provide justification and develop a defensible design criteria.
- Statement of objectives and servicing criteria.
- Identification of existing and proposed infrastructure available in the immediate area.
- Identification of Environmentally Significant Areas, watercourses and Municipal Drains potentially impacted by the proposed development (Reference can be made to the Natural Heritage Studies, if available).
- Concept level master grading plan to confirm existing and proposed grades in the development. This is required to confirm the feasibility of proposed stormwater management and drainage, soil removal and fill constraints, and potential impacts to neighbouring properties. This is also required to confirm that the proposed grading will not impede existing major system flow paths.
- Identification of potential impacts of proposed piped services on private services (such as wells and septic fields on adjacent lands) and mitigation required to address potential impacts.
- Proposed phasing of the development, if applicable.

- Reference to geotechnical studies and recommendations concerning servicing.
- All preliminary and formal site plan submissions should have the following information:
 - Metric scale
 - North arrow (including construction North)
 - Key plan
 - Name and contact information of applicant and property owner
 - Property limits including bearings and dimensions
 - Existing and proposed structures and parking areas
 - Easements, road widening and rights-of-way
 - Adjacent street names

4.2 Development Servicing Report: Water

- Confirm consistency with Master Servicing Study, if available
- Availability of public infrastructure to service proposed development
- Identification of system constraints
- Identify boundary conditions
- Confirmation of adequate domestic supply and pressure
- Confirmation of adequate fire flow protection and confirmation that fire flow is calculated as per the Fire Underwriter's Survey. Output should show available fire flow at locations throughout the development.
- Provide a check of high pressures. If pressure is found to be high, an assessment is required to confirm the application of pressure reducing valves.
- Definition of phasing constraints. Hydraulic modeling is required to confirm servicing for all defined phases of the project including the ultimate design
- Address reliability requirements such as appropriate location of shut-off valves
- Check on the necessity of a pressure zone boundary modification.
- Reference to water supply analysis to show that major infrastructure is capable of delivering sufficient water for the proposed land use. This includes data that shows that the expected demands under average day, peak hour and fire flow conditions provide water within the required pressure range

- Description of the proposed water distribution network, including locations of proposed connections to the existing system, provisions for necessary looping, and appurtenances (valves, pressure reducing valves, valve chambers, and fire hydrants) including special metering provisions.
- Description of off-site required feeder mains, booster pumping stations, and other water infrastructure that will be ultimately required to service proposed development, including financing, interim facilities, and timing of implementation.
- Confirmation that water demands are calculated based on the City of Ottawa Design Guidelines.
- Provision of a model schematic showing the boundary conditions locations, streets, parcels, and building locations for reference.

4.3 Development Servicing Report: Wastewater

- Summary of proposed design criteria (Note: Wet-weather flow criteria should not deviate from the City of Ottawa Sewer Design Guidelines. Monitored flow data from relatively new infrastructure cannot be used to justify capacity requirements for proposed infrastructure).
- Confirm consistency with Master Servicing Study and/or justifications for deviations.
- Consideration of local conditions that may contribute to extraneous flows that are higher than the recommended flows in the guidelines. This includes groundwater and soil conditions, and age and condition of sewers.
- Description of existing sanitary sewer available for discharge of wastewater from proposed development.
- Verify available capacity in downstream sanitary sewer and/or identification of upgrades necessary to service the proposed development. (Reference can be made to previously completed Master Servicing Study if applicable)
- Calculations related to dry-weather and wet-weather flow rates from the development in standard MOE sanitary sewer design table (Appendix 'C') format.
- Description of proposed sewer network including sewers, pumping stations, and forcemains.
- Discussion of previously identified environmental constraints and impact on servicing (environmental constraints are related to limitations imposed on the development in order to preserve the physical condition of watercourses, vegetation, soil cover, as well as protecting against water quantity and quality).
- Pumping stations: impacts of proposed development on existing pumping stations or requirements for new pumping station to service development.
- Forcemain capacity in terms of operational redundancy, surge pressure and maximum flow velocity.
- Identification and implementation of the emergency overflow from sanitary pumping stations in relation to the hydraulic grade line to protect against basement flooding.
- Special considerations such as contamination, corrosive environment etc.

4.4 Development Servicing Report: Stormwater Checklist

- Description of drainage outlets and downstream constraints including legality of outlets (i.e. municipal drain, right-of-way, watercourse, or private property)
- Analysis of available capacity in existing public infrastructure.
- A drawing showing the subject lands, its surroundings, the receiving watercourse, existing drainage patterns, and proposed drainage pattern.
- Water quantity control objective (e.g. controlling post-development peak flows to pre-development level for storm events ranging from the 2 or 5 year event (dependent on the receiving sewer design) to 100 year return period); if other objectives are being applied, a rationale must be included with reference to hydrologic analyses of the potentially affected subwatersheds, taking into account long-term cumulative effects.
- Water Quality control objective (basic, normal or enhanced level of protection based on the sensitivities of the receiving watercourse) and storage requirements.
- Description of the stormwater management concept with facility locations and descriptions with references and supporting information.
- Set-back from private sewage disposal systems.
- Watercourse and hazard lands setbacks.
- Record of pre-consultation with the Ontario Ministry of Environment and the Conservation Authority that has jurisdiction on the affected watershed.
- Confirm consistency with sub-watershed and Master Servicing Study, if applicable study exists.
- Storage requirements (complete with calculations) and conveyance capacity for minor events (1:5 year return period) and major events (1:100 year return period).
- Identification of watercourses within the proposed development and how watercourses will be protected, or, if necessary, altered by the proposed development with applicable approvals.
- Calculate pre and post development peak flow rates including a description of existing site conditions and proposed impervious areas and drainage catchments in comparison to existing conditions.
- Any proposed diversion of drainage catchment areas from one outlet to another.
- Proposed minor and major systems including locations and sizes of stormwater trunk sewers, and stormwater management facilities.
- If quantity control is not proposed, demonstration that downstream system has adequate capacity for the post-development flows up to and including the 100 year return period storm event.
- Identification of potential impacts to receiving watercourses
- Identification of municipal drains and related approval requirements.
- Descriptions of how the conveyance and storage capacity will be achieved for the development.
- 100 year flood levels and major flow routing to protect proposed development from flooding for establishing minimum building elevations (MBE) and overall grading.

- Inclusion of hydraulic analysis including hydraulic grade line elevations.
- Description of approach to erosion and sediment control during construction for the protection of receiving watercourse or drainage corridors.
- Identification of floodplains – proponent to obtain relevant floodplain information from the appropriate Conservation Authority. The proponent may be required to delineate floodplain elevations to the satisfaction of the Conservation Authority if such information is not available or if information does not match current conditions.
- Identification of fill constraints related to floodplain and geotechnical investigation.

4.5 Approval and Permit Requirements: Checklist

The Servicing Study shall provide a list of applicable permits and regulatory approvals necessary for the proposed development as well as the relevant issues affecting each approval. The approval and permitting shall include but not be limited to the following:

- Conservation Authority as the designated approval agency for modification of floodplain, potential impact on fish habitat, proposed works in or adjacent to a watercourse, cut/fill permits and Approval under Lakes and Rivers Improvement Act. The Conservation Authority is not the approval authority for the Lakes and Rivers Improvement Act. Where there are Conservation Authority regulations in place, approval under the Lakes and Rivers Improvement Act is not required, except in cases of dams as defined in the Act.
- Application for Certificate of Approval (CofA) under the Ontario Water Resources Act.
- Changes to Municipal Drains.
- Other permits (National Capital Commission, Parks Canada, Public Works and Government Services Canada, Ministry of Transportation etc.)

4.6 Conclusion Checklist

- Clearly stated conclusions and recommendations
- Comments received from review agencies including the City of Ottawa and information on how the comments were addressed. Final sign-off from the responsible reviewing agency.
- All draft and final reports shall be signed and stamped by a professional Engineer registered in Ontario

APPENDIX C

IDF Curves, SWM Calculations, Storm Sewer Design Sheet

APPENDIX 5-A

OTTAWA INTENSITY DURATION FREQUENCY (IDF) CURVE

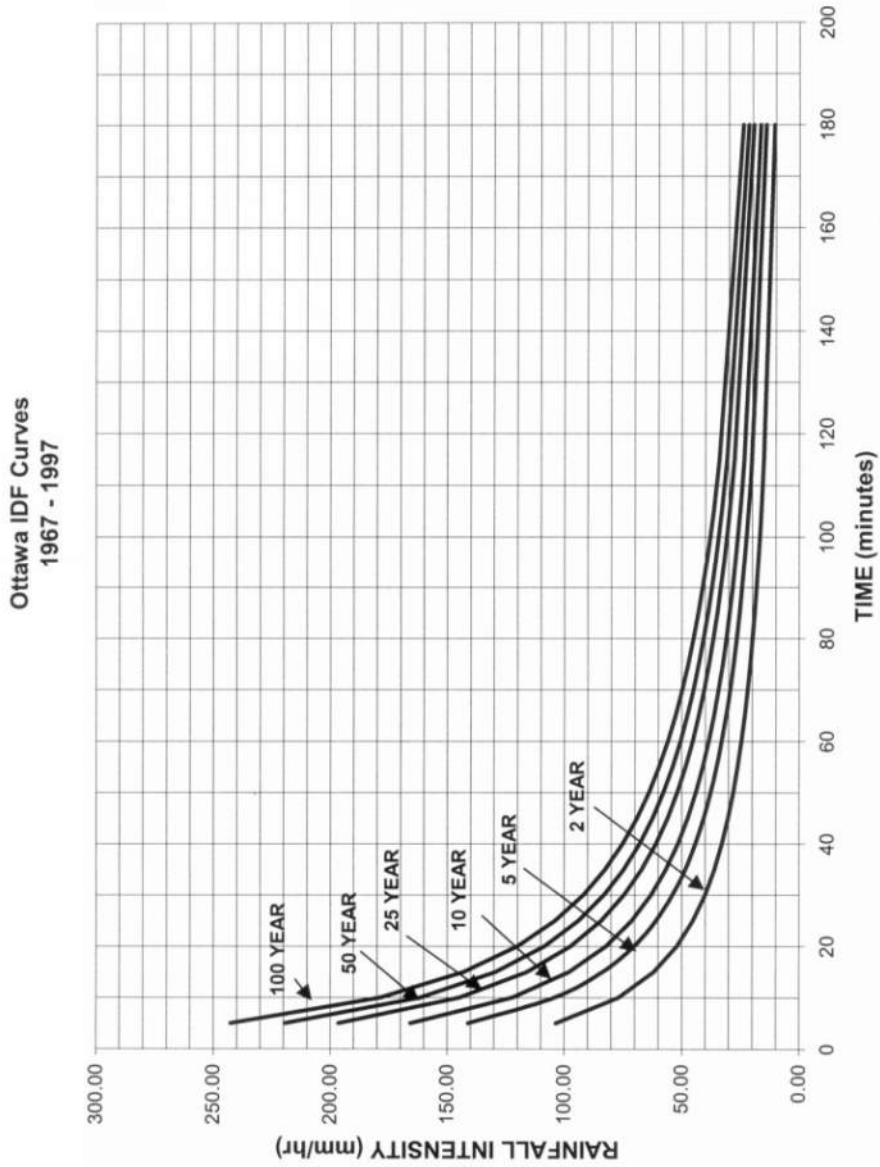

Proposed Parking Lot 600 March Road

Pre - Development Stormwater Flows											
Description	Area (ha)	A _{imperv} (ha) C=0.9	A _{gravel} (ha) C=0.7	A _{pervious} (ha) C=0.2	Weighted C _{w5}	Weighted C _{w100}	2-Year Flow (L/s)	5-Year Flow (L/s)	100-Year Flow (L/s)	Allowable C _{w5}	Allowable Flows
											5-year (L/s)
Subject Site to be Developed	2.298	0.778	0.000	1.520	0.44	0.50	145.3	196.1	386.1	0.44	196.1
Offsite Tributary Area OS-1	0.087	0.002	0.000	0.085	0.22	0.27	2.7	3.7	7.8	0.22	3.7
Offsite Tributary Area OS-2	0.069	0.000	0.000	0.069	0.20	0.25	2.0	2.7	5.8	0.20	2.7
Total	2.454	0.780	0.000	1.674	0.42	0.49	150.0	202.5	399.7	0.42	202.5

T_c = 20mins
 T_c = 20mins
 T_c = 20mins

Post - Development Stormwater Flows																
Area	Description	Area (ha)	A _{imp} (ha) C=0.9	A _{perv} (ha) C=0.2	C _s	C ₁₀₀	Uncontrolled Flow (L/s)			Controlled Flow (L/s)			Storage Required (m ³)			Storage Available (m ³)
							2-year	5-year	100-year	2-year	5-year	100-year	2-year	5-year	100-year	
	Offsite Tributary Area (OS-1)	0.087	0.002	0.085	0.22	0.27										
	Offsite Tributary Area (OS-2)	0.069	0.000	0.069	0.20	0.25										
	Controlled Flow (A-1)	1.533	1.230	0.303	0.76	0.85										
A-1	Controlled Flow (Incl. OS-1 and OS-2 Flows)	1.689	1.232	0.457	0.71	0.80	-	-	-	98.2	98.5	100.9	152.4	236.5	571.7	1009.0
A-2	Controlled Flow (Pond)	0.765	0.501	0.264	0.66	0.74	-	-	-	20.4	23.3	30.2	87.3	124.1	268.4	406.3
Totals :		2.454	-	-	-	-	0.0	0.0	0.0	118.6	121.8	131.1	239.7	360.7	840.1	1415.3
									Total On-Site Stormwater Flows			118.6	121.8	131.1		

Proposed Parking Lot Storage Calculations Using Average Release Rate Equal to 50% of the Qpeak
Novatech Project No. 121334
REQUIRED STORAGE - 1:2 YEAR EVENT
AREA A-2 Controlled Site Flows (Pond)

OTTAWA IDF CURVE Qpeak = 20.4 L/s
 Area = 0.765 ha Qavg = 10.2 L/s
 C = 0.66 Vol(max) = 87.3 m3
 (Vol calculated for Qallow-avg)

Time (min)	Intensity (mm/hr)	Q (L/s)	Qnet (L/s)	Vol (m3)
5	103.57	145.03	134.83	40.45
10	76.81	107.55	97.35	58.41
15	61.77	86.49	76.29	68.66
20	52.03	72.86	62.66	75.19
25	45.17	63.25	53.05	79.57
30	40.04	56.07	45.87	82.57
35	36.06	50.49	40.29	84.62
40	32.86	46.02	35.82	85.97
45	30.24	42.34	32.14	86.79
50	28.04	39.27	29.07	87.20
55	26.17	36.65	26.45	87.27
60	24.56	34.39	24.19	87.08
65	23.15	32.42	22.22	86.65
70	21.91	30.68	20.48	86.03
75	20.81	29.14	18.94	85.25
90	18.14	25.41	15.21	82.11
105	16.13	22.59	12.39	78.07
120	14.56	20.39	10.19	73.37
135	13.30	18.62	8.42	68.18
150	12.25	17.16	6.96	62.60

Proposed Parking Lot Storage Calculations Using Average Release Rate Equal to 50% of the Qpeak
Novatech Project No. 121334
REQUIRED STORAGE - 1:5 YEAR EVENT
AREA A-2 Controlled Site Flows (Pond)

OTTAWA IDF CURVE Qpeak = 23.3 L/s
 Area = 0.765 ha Qavg = 11.7 L/s
 C = 0.66 Vol(max) = 124.1 m3
 (Vol calculated for Qallow-avg)

Time (min)	Intensity (mm/hr)	Q (L/s)	Qnet (L/s)	Vol (m3)
5	141.18	197.69	186.04	55.81
10	104.19	145.90	134.25	80.55
15	83.56	117.00	105.35	94.82
20	70.25	98.37	86.72	104.07
25	60.90	85.27	73.62	110.43
30	53.93	75.51	63.86	114.96
35	48.52	67.94	56.29	118.21
40	44.18	61.87	50.22	120.53
45	40.63	56.89	45.24	122.15
50	37.65	52.73	41.08	123.23
55	35.12	49.18	37.53	123.86
60	32.94	46.13	34.48	124.13
65	31.04	43.47	31.82	124.10
70	29.37	41.13	29.48	123.81
75	27.89	39.05	27.40	123.31
90	24.29	34.01	22.36	120.75
105	21.58	30.22	18.57	117.00
120	19.47	27.26	15.61	112.39
135	17.76	24.88	13.23	107.13
150	16.50	22.80	11.65	104.85

Structures	Size (mm)	Area (m ²)	T/G	Inv IN	Inv OUT
STMMH 116	1200	1.13		79.72	78.12

Area A-2: Storage Table

Elevation (m)	System Depth (m)	STMMH 116 Underground Volume (m ³)	Pond		Total Volume (m ³)	Design Head
			Area (m ²)	Volume (m ³)		
78.11	0.00	0.00	0	0	0.00	-
78.20	0.09	0.10	0.0	0.0	0.10	-0.10
78.35	0.24	0.27	90.4	0.0	0.27	0.05
78.40	0.29	0.33	180.9	6.8	7.11	0.10
78.60	0.49	0.55	220.1	46.9	47.44	0.30
78.80	0.69	0.78	266.3	95.5	96.31	0.50
79.00	0.89	1.01	319.4	154.1	155.10	0.70
79.20	1.09	1.23	379.5	224.0	225.22	0.90
79.35	1.24	1.40	431.1	284.8	286.18	1.05
79.40	1.29	1.46	449.2	306.8	308.24	1.10
79.60	1.49	1.69	528.4	404.5	406.22	1.30
79.65	1.54	1.74	-	404.5	406.28	1.35

Proposed Parking Lot Storage Calculations Using Average Release Rate Equal to 50% of the Qpeak
Novatech Project No. 121334
REQUIRED STORAGE - 1:100 YEAR EVENT
AREA A-2 Controlled Site Flows (Pond)

OTTAWA IDF CURVE Qpeak = 30.2 L/s
 Area = 0.765 ha Qavg = 15.1 L/s
 C = 0.74 Vol(max) = 268.4 m3
 (Vol calculated for Qallow-avg)

Time (min)	Intensity (mm/hr)	Q (L/s)	Qnet (L/s)	Vol (m3)
5	242.70	382.56	367.46	110.24
10	178.56	281.46	266.36	159.81
15	142.89	225.24	210.14	189.12
20	119.95	189.07	173.97	208.77
25	103.85	163.69	148.59	222.88
30	91.87	144.81	129.71	233.47
35	82.58	130.17	115.07	241.64
40	75.15	118.45	103.35	248.04
45	69.05	108.84	93.74	253.10
50	63.95	100.81	85.71	257.12
55	59.62	93.98	78.88	260.31
60	55.89	88.10	73.00	262.82
65	52.65	82.98	67.88	264.75
70	49.79	78.48	63.38	266.20
75	47.26	74.49	59.39	267.24
90	41.11	64.80	49.70	268.39
105	36.50	57.53	42.43	267.31
120	32.89	51.85	36.75	264.61
135	30.00	47.28	32.18	260.68
150	27.61	43.52	28.42	255.79

Proposed Parking Lot Storage Calculations Using Average Release Rate Equal to 50% of the Qpeak
Novatech Project No. 121334
REQUIRED STORAGE - 1:100 YR + 20% IDF Increase
AREA A-2 Controlled Site Flows (Pond)

OTTAWA IDF CURVE Qpeak = 30.2 L/s
 Area = 0.765 ha Qavg = 15.1 L/s
 C = 0.74 Vol(max) = 268.4 m3
 (Vol calculated for Qallow-avg)

Time (min)	Intensity (mm/hr)	Q (L/s)	Qnet (L/s)	Vol (m3)
5	291.24	459.08	443.98	133.19
10	214.27	337.75	322.65	193.59
15	171.47	270.29	255.19	229.67
20	143.94	226.89	211.79	254.15
25	124.62	196.43	181.33	271.99
30	110.24	173.77	158.67	285.61
35	99.09	156.20	141.10	296.31
40	90.17	142.14	127.04	304.89
45	82.86	130.61	115.51	311.88
50	76.74	120.97	105.87	317.61
55	71.55	112.78	97.68	322.34
60	67.07	105.73	90.63	326.25
65	63.18	99.58	84.48	329.48
70	59.75	94.18	79.08	332.13
75	56.71	89.38	74.28	334.28
90	49.33	77.76	62.66	338.37
105	43.80	69.04	53.94	339.79
120	39.47	62.22	47.12	339.27
135	36.00	56.74	41.64	337.28
150	33.13	52.23	37.13	334.13

Plug Type ICD w/ 118mm Dia. Orifice

1:100 Yr
 Flow (L/s) = 30.2
 Head (m) = 1.01
 Elevation (m) = 79.31
 Outlet Pipe Dia. (mm) = 375
 Volume (m3) = 268.4

1:5 Yr
 Flow (L/s) = 23.3
 Head (m) = 0.60
 Elevation (m) = 78.90
 Outlet Pipe Dia. (mm) = 375
 Volume (m3) = 124.1

1:2 Yr
 Flow (L/s) = 20.4
 Head (m) = 0.46
 Elevation (m) = 78.76
 Outlet Pipe Dia. (mm) = 375
 Volume (m3) = 87.3

Orifice Size - 1:100 yr Flow Check
 $Q=0.62Ax\sqrt{2gh}^{0.5}$

	1:100 yr	Flow Check
Q (m ³ /s) =	0.0302	0.0302
g (m/s ²) =	9.81	9.81
h (m) =	1.01	1.01

A (m²) = 0.010928693 0.01094
 D (m) = 0.117961199 0.11800
 D (mm) = 118 118.0

1:5 yr Flow Check

	1:5 yr
Q (m ³ /s) =	0.0233
g (m/s ²) =	9.81
h (m) =	0.60

A (m²) = 0.01094
 D (m) = 0.118
 D (mm) = 118

1:2 yr Flow Check

	1:2 yr
Q (m ³ /s) =	0.0204
g (m/s ²) =	9.81
h (m) =	0.46

A (m²) = 0.01094
 D (m) = 0.118
 D (mm) = 118

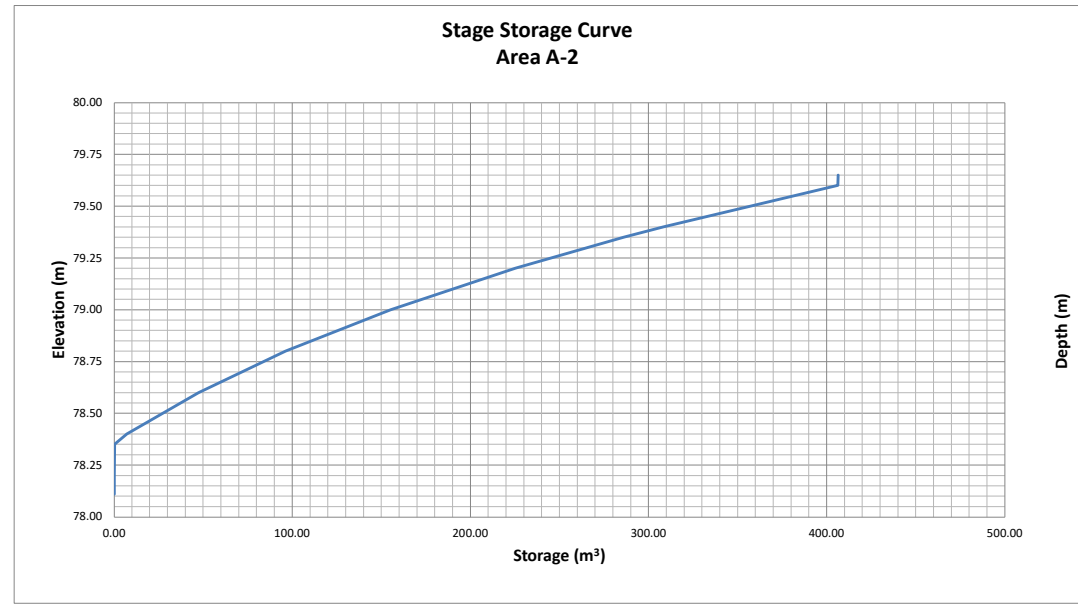

STORM SEWER DESIGN SHEET



Novatech Project #: 121334
 Project Name: Nokia Parking Lot Expansion
 Date Prepared: 9/28/2023
 Date Revised: 1/29/2024
 Input By: Chris Visser
 Reviewed By: François Thauvette
 Drawing Reference: 121334-STM

Legend:
 PROJECT SPECIFIC INFO
 USER DESIGN INPUT
 CUMULATIVE CELL
 CALCULATED DESIGN CELL OUTPUT
 USER AS-BUILT INPUT

LOCATION		DEMAND											CAPACITY										
From MH	To MH	AREA					FLOW						PROPOSED SEWER PIPE SIZING / DESIGN										
		Area ID	Pavement	Landscaped area	Total Area	Weighted Runoff Coefficient	Indivi 2.78 AR	Accum 2.78 AR	Time of Concentration	Rain Intensity (mm/hr)			Peak Flow	TOTAL PEAK FLOW (QDesign)	PIPE PROPERTIES					CAPACITY	FULL FLOW VELOCITY	TIME OF FLOW	QPEAK DESIGN / QFULL
			0.90	0.20	(ha)			(min.)	2yr	5yr	100yr	(L/s)	(L/s)	LENGTH (m)	SIZE / MATERIAL (mm / type)	ID ACTUAL (m)	ROUGHNESS	DESIGN GRADE (%)	(L/s)	(m/s)	(min.)	(%)	
CDS OGS Unit to Ex. Storm																							
CB-01	CBMH-100	A-1a	0.000 0.128 0.000	0.098	0.226	0.60	0.00 0.37 0.00	0.00 0.37 0.00	10.00 10.00 10.00		104.19		0.00 38.94 0.00	38.9	25.5	375 PVC	0.381	0.013	0.25	91.5	0.80	0.53	42.6%
CBMH 100	CBMH 102	A-1b	0.000 0.100 0.000	0.037	0.137	0.71	0.00 0.27 0.00	0.00 0.64 0.00	10.00 10.53 10.00		101.48		0.00 65.36 0.00	65.4	42.3	375 PVC	0.381	0.013	0.25	91.5	0.80	0.88	71.5%
CB-02	CBMH-102	A-1c	0.000 0.076 0.000	0.017	0.093	0.77	0.00 0.20 0.00	0.00 0.20 0.00	10.00 10.00 10.00		104.19		0.00 20.86 0.00	20.9	19.3	375 PVC	0.381	0.013	0.25	91.5	0.80	0.40	22.8%
CBMH-102	CBMH-104	A-1d	0.000 0.140 0.000	0.047	0.187	0.72	0.00 0.38 0.00	0.00 1.22 0.00	10.00 11.41 10.00		97.30		0.00 118.76 0.00	118.8	34.0	375 PVC	0.381	0.013	0.43	119.9	1.05	0.54	99.0%
CBMH-104	CBMH-106	A-1e	0.000 0.124 0.000	0.035	0.159	0.75	0.00 0.33 0.00	0.00 1.55 0.00	10.00 11.95 10.00		94.92		0.00 147.17 0.00	147.2	12.4	375 PVC	0.381	0.013	0.65	147.5	1.29	0.16	99.8%
CBMH-106	STMMH-120	A-1f	0.000 0.052 0.000	0.023	0.075	0.69	0.00 0.14 0.00	0.00 1.69 0.00	10.00 12.11 10.00		94.24		0.00 159.55 0.00	159.6	58.9	375 PVC	0.381	0.013	0.77	160.5	1.41	0.70	99.4%
CB-06	STMMH-120	A-1h	0.000 0.070 0.000	0.078	0.147	0.53	0.00 0.22 0.00	0.00 0.22 0.00	10.00 10.00 10.00		104.19		0.00 22.66 0.00	22.7	19.7	375 PVC	0.381	0.013	0.25	91.5	0.80	0.41	24.8%
STMMH-120	STMMH-112	A-1i	0.000 0.000 0.000	0.000	0.000		0.00 0.00 0.00	0.00 1.91 0.00	10.00 12.80 10.00		91.39		0.00 174.61 0.00	174.6	32.4	375 PVC	0.381	0.013	0.92	175.4	1.54	0.35	99.5%
CB-03	CBMH-108	A-1g	0.000 0.116 0.000	0.041	0.157	0.72	0.00 0.31 0.00	0.00 0.31 0.00	10.00 10.00 10.00		104.19		0.00 32.72 0.00	32.7	28.2	375 PVC	0.381	0.013	0.35	108.2	0.95	0.50	30.2%
CBMH-108	CBMH-110	A-1i	0.000 0.178 0.000	0.060	0.238	1.17	0.00 0.48 0.00	0.00 0.79 0.00	10.00 10.50 10.00		101.65		0.00 80.51 0.00	80.5	31.2	375 PVC	0.381	0.013	0.35	108.2	0.95	0.55	74.4%
CB-04	CBMH-110	A-1j	0.000 0.170 0.000	0.072	0.241	0.69	0.00 0.46 0.00	0.00 0.46 0.00	10.00 10.00 10.00		104.19		0.00 48.35 0.00	48.4	27.3	375 PVC	0.381	0.013	0.35	108.2	0.95	0.48	44.7%
CBMH-110	STMMH-112	A-1k	0.000 0.126 0.000	0.048	0.175	0.71	0.00 0.34 0.00	0.00 1.60 0.00	10.00 11.04 10.00		98.99		0.00 158.30 0.00	158.3	13.5	375 PVC	0.381	0.013	0.75	158.4	1.39	0.16	99.9%
STMMH-112	STMMH-114	A-1k	0.000 0.000 0.000	0.000	0.000		ICD Downstream of CBMH 116: 5-Yr Flow Controlled to 98.9						98.9	74.1	375 PVC	0.381	0.013	0.35	108.2	0.95	1.30	91.4%	
STMMH-114	OGS Unit	A-1l	0.000 0.000 0.000	0.000	0.000		0.00 0.00 0.00	0.00 1.14 0.00	10.00 14.456456 10.00		85.36		0.00 97.53 0.00	97.5	53.1	375 PVC	0.381	0.013	0.35	108.2	0.95	0.93	90.1%
SWM Pond	STMMH-116	A-1l	0.000 0.428 0.000	0.190	0.618	0.68	0.00 1.18 0.00	0.00 1.18 0.00	10.00 10.00 10.00		104.19		0.00 122.62 0.00	122.6	11.0	375 PVC	0.381	0.013	2.00	258.7	2.27	0.08	47.4%
STMMH-116	OGS Unit	A-1l	0.000 0.000 0.000	0.000	0.000		ICD Downstream of CBMH 116: 5-Yr Flow Controlled to 23.3						23.3	5.3	375 PVC	0.381	0.013	2.00	258.7	2.27	0.04	9.0%	
OGS Unit	STMMH-122	A-1l	0.000 0.000 0.000	0.000	0.000		0.00 0.00 0.00	0.00 1.39 0.00	10.00 15.388872 10.00		82.32		0.00 114.19 0.00	114.2	31.0	375 PVC	0.381	0.013	0.40	115.7	1.01	0.51	98.7%
STMMH-122	Ex. Storm	A-1l	0.000 0.000 0.000	0.000	0.000		0.00 0.00 0.00	0.00 1.39 0.00	10.00 15.90 10.00		80.76		0.00 112.03 0.00	112.0	6.3	375 PVC	0.381	0.013	0.40	115.7	1.01	0.10	96.8%

DEMAND EQUATION
 $Q = 2.78 \text{ AIR}$

Where : Q = Peak flow in litres per second (L/s)
 A = Area in hectares (ha)
 R = Weighted runoff coefficient (increased by 25% for 100-year)
 I = Rainfall intensity in millimeters per hour (mm/hr)
 Rainfall Intensity (I) is based on City of Ottawa IDF data presented in the City of Ottawa Sewer Design Guidelines (Oct. 2012)

CAPACITY EQUATION

$Q \text{ full} = (1/n) A R^{2/3} S_o^{1/2}$

Where : Q full = Capacity (L/s)
 n = Manning coefficient of roughness (0.013)
 A = Flow area (m²)
 R = Wetter perimeter (m)
 S_o = Pipe Slope/gradient

APPENDIX D

Inlet Control Device (ICD) Information

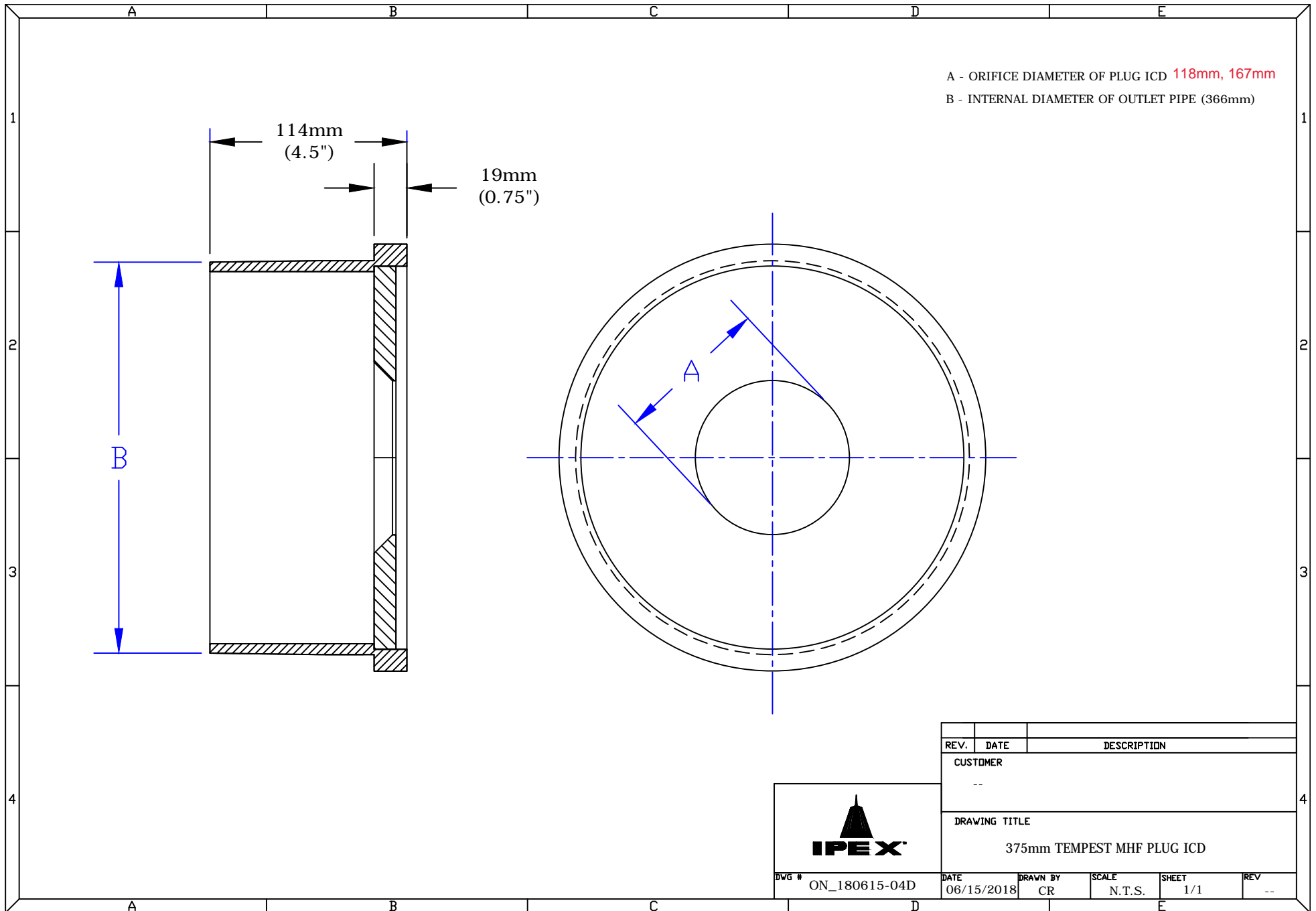

A - ORIFICE DIAMETER OF PLUG ICD **118mm, 167mm**
 B - INTERNAL DIAMETER OF OUTLET PIPE (366mm)

114mm
(4.5")
 19mm
(0.75")

B

A



REV.	DATE	DESCRIPTION			
CUSTOMER					
--					
DRAWING TITLE					
375mm TEMPEST MHF PLUG ICD					
DWG #	DATE	DRAWN BY	SCALE	SHEET	REV
ON_180615-04D	06/15/2018	CR	N.T.S.	1/1	--

APPENDIX E

Stormwater Quality Treatment Unit Information



**CDS ESTIMATED NET ANNUAL SOLIDS LOAD REDUCTION
BASED ON THE RATIONAL RAINFALL METHOD
BASED ON A FINE PARTICLE SIZE DISTRIBUTION**



Project Name: 600 March Road

Engineer: Novatech

Location: Ottawa, ON

Contact: Zarak Ali, B.A.Sc., EIT

OGS #: 1

Report Date: 3-Oct-23

Area 2.454 ha

Rainfall Station # 215

Weighted C 0.69

Particle Size Distribution FINE

CDS Model 3025

CDS Treatment Capacity 68 l/s

<u>Rainfall Intensity¹</u> <u>(mm/hr)</u>	<u>Percent Rainfall Volume¹</u>	<u>Cumulative Rainfall Volume</u>	<u>Total Flowrate (l/s)</u>	<u>Treated Flowrate (l/s)</u>	<u>Operating Rate (%)</u>	<u>Removal Efficiency (%)</u>	<u>Incremental Removal (%)</u>
1.0	10.6%	19.8%	4.7	4.7	6.9	96.9	10.3
1.5	9.9%	29.7%	7.1	7.1	10.4	95.9	9.5
2.0	8.4%	38.1%	9.4	9.4	13.9	94.9	8.0
2.5	7.7%	45.8%	11.8	11.8	17.3	93.9	7.2
3.0	5.9%	51.7%	14.1	14.1	20.8	92.9	5.5
3.5	4.4%	56.1%	16.5	16.5	24.2	91.9	4.0
4.0	4.7%	60.7%	18.8	18.8	27.7	90.9	4.2
4.5	3.3%	64.0%	21.2	21.2	31.2	89.9	3.0
5.0	3.0%	67.1%	23.5	23.5	34.6	88.9	2.7
6.0	5.4%	72.4%	28.2	28.2	41.6	86.9	4.7
7.0	4.4%	76.8%	33.0	33.0	48.5	85.0	3.7
8.0	3.5%	80.3%	37.7	37.7	55.4	83.0	2.9
9.0	2.8%	83.2%	42.4	42.4	62.3	81.0	2.3
10.0	2.2%	85.3%	47.1	47.1	69.3	79.0	1.7
15.0	7.0%	92.3%	70.6	68.0	100.0	67.6	4.7
20.0	4.5%	96.9%	94.1	68.0	100.0	50.7	2.3
25.0	1.4%	98.3%	117.7	68.0	100.0	40.5	0.6
30.0	0.7%	99.0%	141.2	68.0	100.0	33.8	0.2
35.0	0.5%	99.5%	164.8	68.0	100.0	29.0	0.1
40.0	0.5%	100.0%	188.3	68.0	100.0	25.3	0.1
45.0	0.0%	100.0%	211.8	68.0	100.0	22.5	0.0
50.0	0.0%	100.0%	235.4	68.0	100.0	20.3	0.0

86.8

Removal Efficiency Adjustment² = 6.5%

Predicted Net Annual Load Removal Efficiency = 80.3%

Predicted Annual Rainfall Treated = 96.5%

1 - Based on 42 years of hourly rainfall data from Canadian Station 6105976, Ottawa ON

2 - Reduction due to use of 60-minute data for a site that has a time of concentration less than 30-minutes.

3 - CDS Efficiency based on testing conducted at the University of Central Florida

4 - CDS design flowrate and scaling based on standard manufacturer model & product specifications

Z:\4.0 MANUFACTURERS\CONTECH PRODUCT INFO\TREATMENT\CDSDRAWINGS ECHELONIN LINE-PDF\2022 - PMSU UPDATED CONTECH DRAWINGS - HUDA\6\CD3025-6-C-DTL.DWG 6/3/2022 10:07 AM

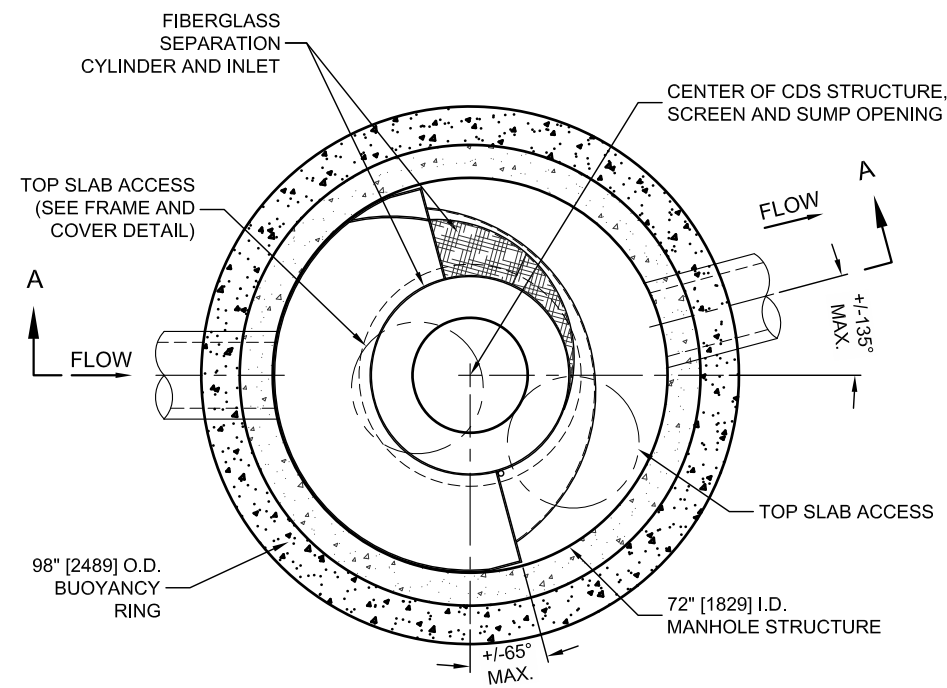

PLAN VIEW B-B
N.T.S.

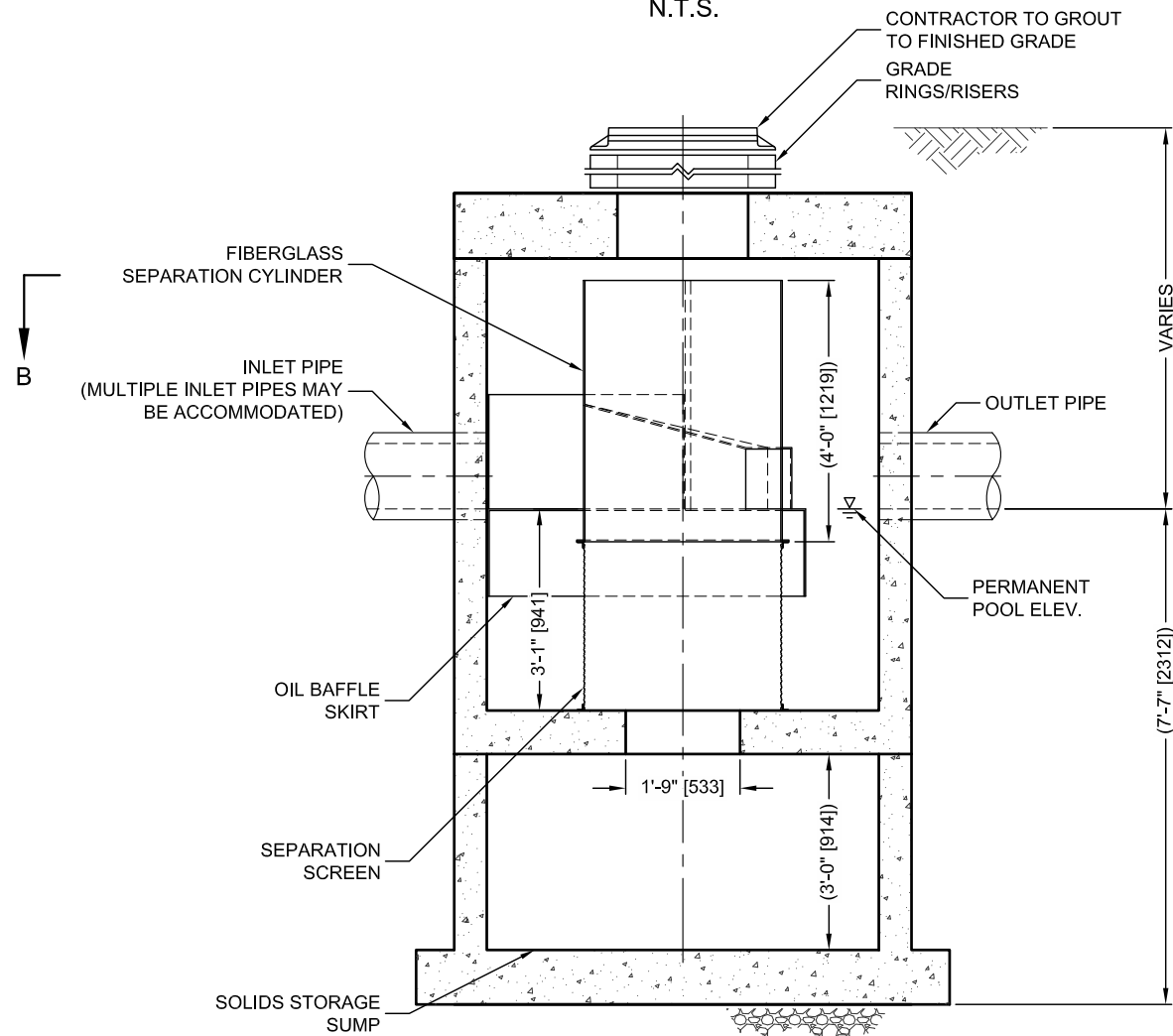

ELEVATION A-A
N.T.S.



THIS PRODUCT MAY BE PROTECTED BY ONE OR MORE OF THE FOLLOWING U.S. PATENTS: 6,788,848; 6,841,722; 6,911,502; 6,981,783; RELATED FOREIGN PATENTS, OR OTHER PATENTS-PENDING.

CDS PMSU3025-6-C DESIGN NOTES

THE STANDARD CDS PMSU3025-6-C CONFIGURATION IS SHOWN. ALTERNATE CONFIGURATIONS ARE AVAILABLE AND ARE LISTED BELOW. SOME CONFIGURATIONS MAY BE COMBINED TO SUIT SITE REQUIREMENTS.

CONFIGURATION DESCRIPTION

- GRATED INLET ONLY (NO INLET PIPE)
- GRATED INLET WITH INLET PIPE OR PIPES
- CURB INLET ONLY (NO INLET PIPE)
- CURB INLET WITH INLET PIPE OR PIPES
- CUSTOMIZABLE SUMP DEPTH AVAILABLE
- ANTI-FLOTATION DESIGN AVAILABLE UPON REQUEST

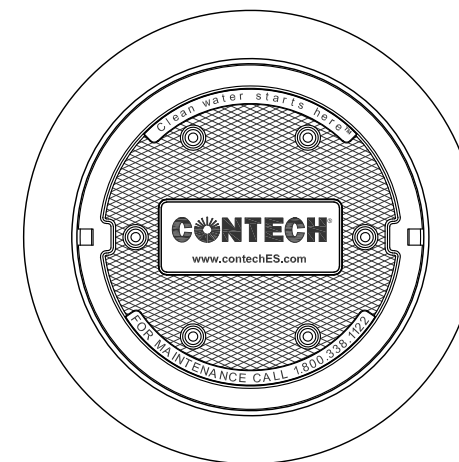

FRAME AND COVER
(DIAMETER VARIES)
N.T.S.

SITE SPECIFIC DATA REQUIREMENTS

STRUCTURE ID				
WATER QUALITY FLOW RATE (CFS OR L/s)				*
PEAK FLOW RATE (CFS OR L/s)				*
RETURN PERIOD OF PEAK FLOW (YRS)				*
SCREEN APERTURE (2400 OR 4700)				*
PIPE DATA:	I.E.	MATERIAL	DIAMETER	
INLET PIPE 1	*	*	*	
INLET PIPE 2	*	*	*	
OUTLET PIPE	*	*	*	
RIM ELEVATION				*
ANTI-FLOTATION BALLAST	WIDTH	HEIGHT		
	*	*		
NOTES/SPECIAL REQUIREMENTS:				
* PER ENGINEER OF RECORD				

GENERAL NOTES

1. CONTECH TO PROVIDE ALL MATERIALS UNLESS NOTED OTHERWISE.
2. DIMENSIONS MARKED WITH () ARE REFERENCE DIMENSIONS. ACTUAL DIMENSIONS MAY VARY.
3. FOR FABRICATION DRAWINGS WITH DETAILED STRUCTURE DIMENSIONS AND WEIGHTS, PLEASE CONTACT YOUR CONTECH ENGINEERED SOLUTIONS LLC REPRESENTATIVE. www.contechES.com
4. CDS WATER QUALITY STRUCTURE SHALL BE IN ACCORDANCE WITH ALL DESIGN DATA AND INFORMATION CONTAINED IN THIS DRAWING.
5. STRUCTURE SHALL MEET AASHTO HS20 AND CASTINGS SHALL MEET HS20 (AASHTO M 306) LOAD RATING, ASSUMING GROUNDWATER ELEVATION AT, OR BELOW, THE OUTLET PIPE INVERT ELEVATION. ENGINEER OF RECORD TO CONFIRM ACTUAL GROUNDWATER ELEVATION.
6. PVC HYDRAULIC SHEAR PLATE IS PLACED ON SHELF AT BOTTOM OF SCREEN CYLINDER. REMOVE AND REPLACE AS NECESSARY DURING MAINTENANCE CLEANING.

INSTALLATION NOTES

- A. ANY SUB-BASE, BACKFILL DEPTH, AND/OR ANTI-FLOTATION PROVISIONS ARE SITE-SPECIFIC DESIGN CONSIDERATIONS AND SHALL BE SPECIFIED BY ENGINEER OF RECORD.
- B. CONTRACTOR TO PROVIDE EQUIPMENT WITH SUFFICIENT LIFTING AND REACH CAPACITY TO LIFT AND SET THE CDS MANHOLE STRUCTURE (LIFTING CLUTCHES PROVIDED).
- C. CONTRACTOR TO ADD JOINT SEALANT BETWEEN ALL STRUCTURE SECTIONS, AND ASSEMBLE STRUCTURE.
- D. CONTRACTOR TO PROVIDE, INSTALL, AND GROUT PIPES. MATCH PIPE INVERTS WITH ELEVATIONS SHOWN.
- E. CONTRACTOR TO TAKE APPROPRIATE MEASURES TO ASSURE UNIT IS WATER TIGHT, HOLDING WATER TO FLOWLINE INVERT MINIMUM. IT IS SUGGESTED THAT ALL JOINTS BELOW PIPE INVERTS ARE GROUTED.



www.contechES.com
9025 Centre Pointe Dr., Suite 400, West Chester, OH 45069
800-338-1122 513-645-7000 513-645-7993 FAX

CDS PMSU3025-6-C
INLINE CDS
STANDARD DETAIL

Chris Visser

From: Patrick <patrick@echelonenvironmental.ca>
Sent: Tuesday, October 3, 2023 1:29 PM
To: Zarak Ali
Cc: Francois Thauvette
Subject: RE: CDS Sizing Request - 600 March Road Parking Lot Expansion in Ottawa (121334)
Attachments: CDS TSSR - 600 March Road - PMSU 3025_6.pdf

Good afternoon Zarak,

Thank you for reaching out! Please find attached our CDS TSS calculations for 600 March Road. For this project I recommend a CDS PMSU 3025_6 which has a treatment flow rate of 68 L/s. Requested parameters are below. Please let me know if you have any questions!

- % of net annual TSS removal – 80.3%
- % of net annual treatment volume for the tributary area – 96.5%
- The treatment capacity in L/s – 68 L/s
- The sediment storage capacity in m3 – 2.402 m3
- The oil storage capacity in L – 795 L
- The total unit storage capacity in L 4920 L

Best regards,

Patrick Graham
Project Manager



*****Please note our new addresses*****

Echelon Environmental Inc.
55 Albert Street
Suite 200
Markham, ON
L3P 2T4
Phone: 1-905-948-0000
Cell: 416-460-5819
Fax: 1-905-948-0577
email patrick@echelonenvironmental.ca

Mailing Address:
Echelon Environmental Inc.
5694 Hwy #7 East
Suite 354
Markham, ON
L3P 0E3

From: Zarak Ali <z.ali@novatech-eng.com>
Sent: Thursday, September 28, 2023 10:35 AM
To: Patrick <patrick@echelonenvironmental.ca>
Cc: Francois Thauvette <f.thauvette@novatech-eng.com>
Subject: CDS Sizing Request - 600 March Road Parking Lot Expansion in Ottawa (121334)

Hi Patrick,

We are currently working on a project that requires a stormwater quality control unit to treat water from the paved drive aisles and parking lots on-site. The project proposes to design the expansion of an existing parking lot and is located at 600 March Road in the City of Ottawa.

The project details are as follows:

Tributary area = **2.454 ha**

Imperviousness = **70%** or $Cw_5=0.69$

2-year controlled peak flow conveyed to unit: **114.8 L/s**

5-year controlled peak flow conveyed to unit: **117.9 L/s**

100-year controlled peak flow conveyed to unit: **127.7 L/s**

Time of concentration = 10min

IDF Curve = City of Ottawa (76.8mm/hr Intensity for 2yr) (104.2mm/hr Intensity for 5yr) (178.6mm/hr Intensity for 100yr)

We have a requirement to provide a level of quality control treatment to meet the MOE 'Enhanced' Level of Protection guidelines (i.e., 80% TSS removal and 90% of annual runoff treated). The proposed unit will be installed on a new 375mm dia. PVC outlet pipe with two (2) 375mm dia. PVC inlet pipes. A standard particle distribution (Fines) should be adequate for the design. See the attached mark-up of the Post-Development Stormwater Management Plan (121334-SWM) for a sketch of the area and proposed water quality treatment unit location (highlighted in yellow).

Can you please size a CDS unit for us and provide the design details as well as an approximate cost estimate?.

We will also need the following information on the unit for our SWM Report:

- % of net annual TSS removal
- % of net annual treatment volume for the tributary area
- The treatment capacity in L/s
- The sediment storage capacity in m³
- The oil storage capacity in L
- The total unit storage capacity in L

Thank you for your time and consideration in this matter. We are looking to submit to the city soon, so if you could get us something as soon as possible, it would be greatly appreciated. If there is any further information you require, please do not hesitate to reach out. **Please reply all to this email.**

Regards,

Zarak Ali, B.A.Sc., EIT | Land Development Engineering

NOVATECH

Engineers, Planners & Landscape Architects

240 Michael Cowpland Drive, Suite 200, Ottawa, ON, K2M 1P6 | Tel: 613.254.9643 Ext: 330

The information contained in this email message is confidential and is for exclusive use of the addressee.

APPENDIX F
Engineering Drawings

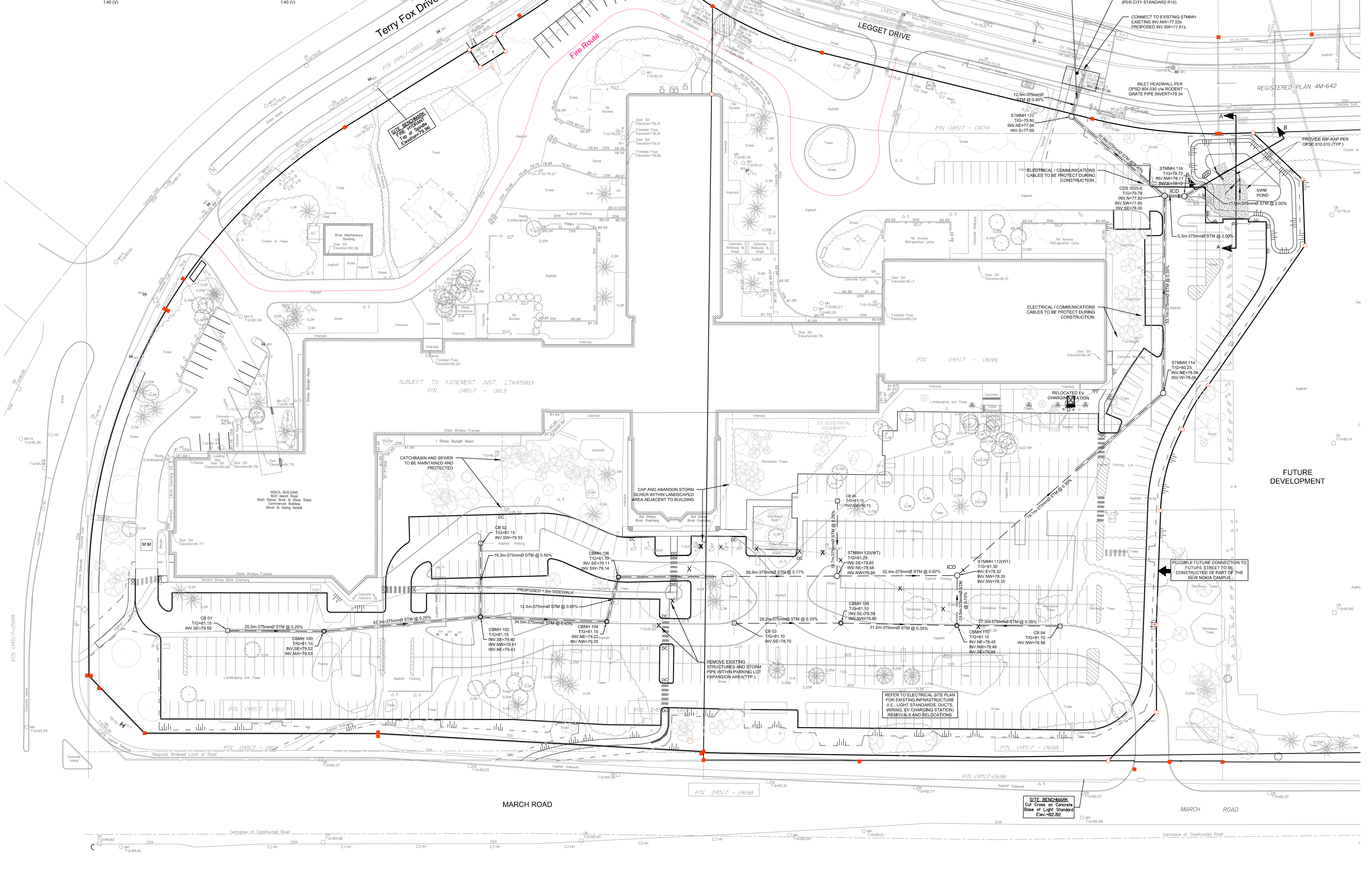
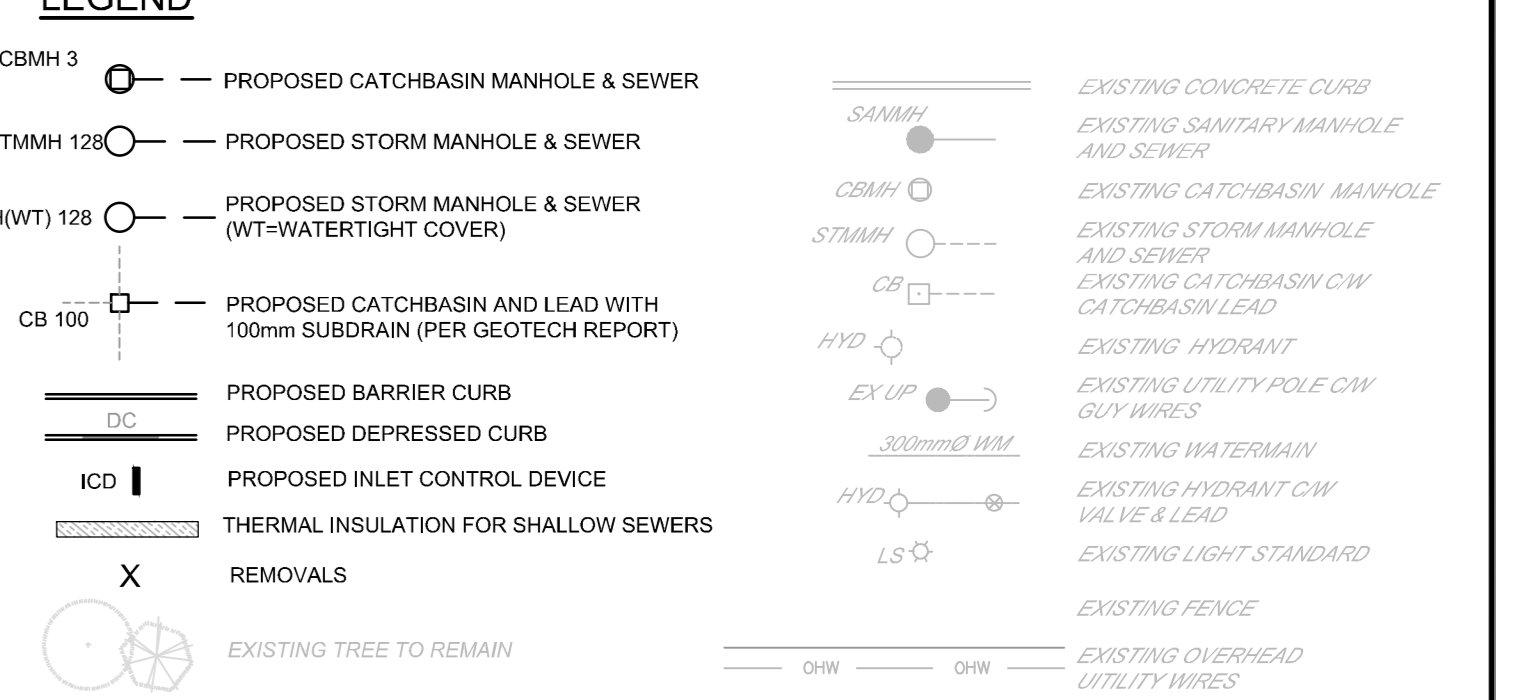
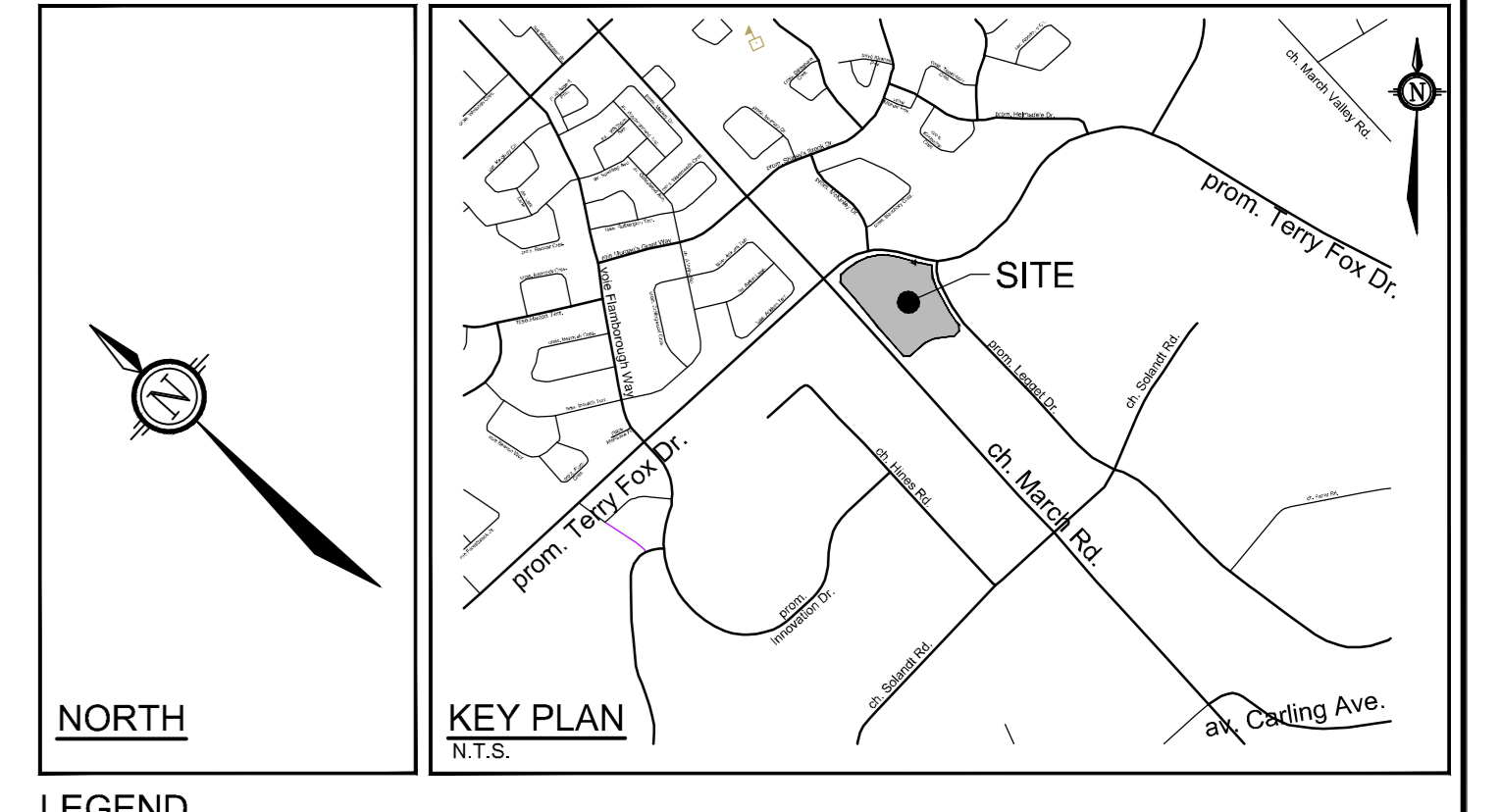
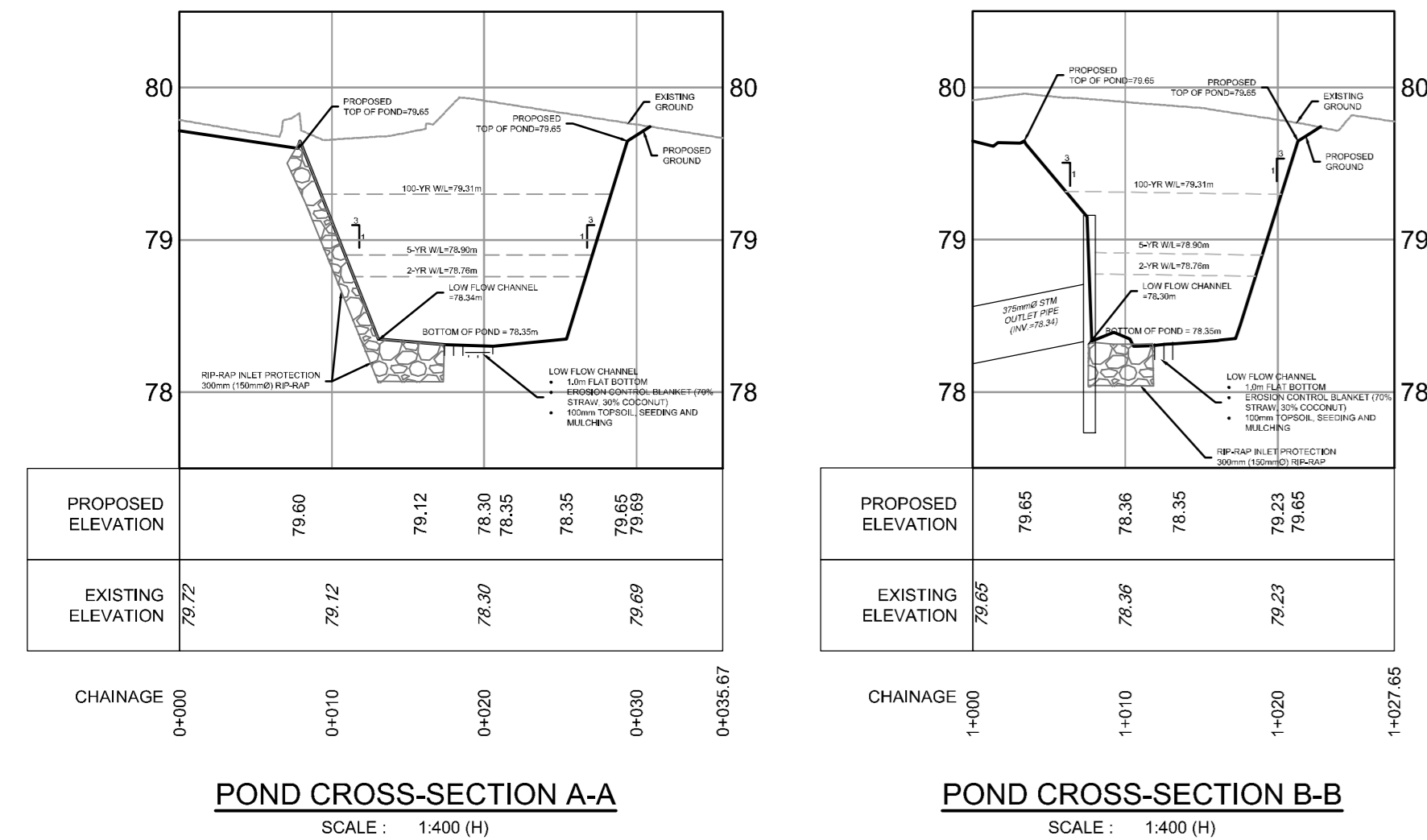

- GENERAL NOTES:**
- COORDINATE AND SCHEDULE ALL WORK WITH OTHER TRADES AND CONTRACTORS.
 - DETERMINE THE EXACT LOCATION, SIZE, MATERIAL AND ELEVATION OF ALL EXISTING UTILITIES PRIOR TO COMMENCING CONSTRUCTION. PROTECT AND ASSUME RESPONSIBILITY FOR ALL EXISTING UTILITIES WHETHER OR NOT SHOWN ON THIS DRAWING.
 - OBTAIN ALL NECESSARY PERMITS AND APPROVALS FROM THE CITY OF OTTAWA BEFORE COMMENCING CONSTRUCTION.
 - BEFORE COMMENCING CONSTRUCTION OBTAIN AND PROVIDE PROOF OF COMPREHENSIVE ALL RISK AND OPERATIONAL LIABILITY INSURANCE FOR \$3,000,000.00. INSURANCE POLICY TO NAME OWNERS, ENGINEERS AND ARCHITECTS AS CO-INSURED.
 - REMOVE ALL DISTURBED AREAS ON-SITE AND OFF-SITE, INCLUDING TRENCHES AND SURFACES ON PUBLIC ROAD ALLOWANCES TO EXISTING CONDITIONS OR BETTER TO THE SATISFACTION OF THE CITY OF OTTAWA AND ENGINEER.
 - REMOVE FROM SITE ALL EXCESS EXCAVATED MATERIAL, ORGANIC MATERIAL AND DEBRIS UNLESS OTHERWISE INSTRUCTED BY ENGINEER. EVACUATE AND REMOVE FROM SITE ANY CONTAMINATED MATERIAL. ALL CONTAMINATED MATERIAL SHALL BE DISPOSED OF AT A LICENSED LANDFILL FACILITY.
 - ALL ELEVATIONS ARE GEODETIC.
 - REFER TO THE GEOTECHNICAL INVESTIGATION AND HYDROLOGICAL ASSESSMENT - 600 MARCH ROAD - (REPORT NO. 1269873-RPT-1), PREPARED BY GHD ON JUNE 16, 2023, FOR SUBSURFACE CONDITIONS, CONSTRUCTION RECOMMENDATIONS, AND GEOTECHNICAL INSPECTION REQUIREMENTS. THE GEOTECHNICAL CONSULTANT IS TO REVIEW ON-SITE CONDITIONS AFTER EXCAVATION PRIOR TO PLACEMENT OF THE GRANULAR MATERIAL.
 - REFER TO ARCHITECTS AND LANDSCAPE ARCHITECT'S DRAWINGS FOR BUILDING AND HARDSCAPE AREAS AND DIMENSIONS.
 - REFER TO STORMWATER MANAGEMENT REPORT-2023-143 (PREPARED BY NOVATECH ENGINEERING CONSULTANTS LTD).
 - PROVIDE LINE-PANING PAINTING.
 - REFER TO THE GEOTECHNICAL INVESTIGATION AND HYDROLOGICAL ASSESSMENT - 600 MARCH ROAD - (REPORT NO. 1269873-RPT-1), PREPARED BY GHD ON JUNE 16, 2023, FOR SUBSURFACE CONDITIONS, CONSTRUCTION RECOMMENDATIONS, AND GEOTECHNICAL INSPECTION REQUIREMENTS. THE GEOTECHNICAL CONSULTANT IS TO REVIEW ON-SITE CONDITIONS AFTER EXCAVATION PRIOR TO PLACEMENT OF THE GRANULAR MATERIAL.
 - REFER TO ARCHITECTS AND LANDSCAPE ARCHITECT'S DRAWINGS FOR BUILDING AND HARDSCAPE AREAS AND DIMENSIONS.
 - REFER TO STORMWATER MANAGEMENT REPORT-2023-143 (PREPARED BY NOVATECH ENGINEERING CONSULTANTS LTD).
 - REFER TO THE GEOTECHNICAL INVESTIGATION AND HYDROLOGICAL ASSESSMENT - 600 MARCH ROAD - (REPORT NO. 1269873-RPT-1), PREPARED BY GHD ON JUNE 16, 2023, FOR SUBSURFACE CONDITIONS, CONSTRUCTION RECOMMENDATIONS, AND GEOTECHNICAL INSPECTION REQUIREMENTS. THE GEOTECHNICAL CONSULTANT IS TO REVIEW ON-SITE CONDITIONS AFTER EXCAVATION PRIOR TO PLACEMENT OF THE GRANULAR MATERIAL.
 - REFER TO ARCHITECTS AND LANDSCAPE ARCHITECT'S DRAWINGS FOR BUILDING AND HARDSCAPE AREAS AND DIMENSIONS.
 - REFER TO STORMWATER MANAGEMENT REPORT-2023-143 (PREPARED BY NOVATECH ENGINEERING CONSULTANTS LTD).

SEWER NOTES:

- SUPPLY AND CONSTRUCT ALL SEWERS AND APPURTENANCES IN ACCORDANCE WITH THE MOST CURRENT CITY OF OTTAWA STANDARDS AND SPECIFICATIONS.
- SPECIFICATIONS:

ITEM	SPEC. No.	REFERENCE
CATCHBASIN (600x600mm)	705.010	OPSD
STORM SANITARY MANHOLE (1200mm)	705.010	OPSD
CE, FRAME & COVER	S19	CITY OF OTTAWA
STORM SANITARY MH FRAME & COVER	401.010 - TYPE "A"	CITY OF OTTAWA
WATERTIGHT MH FRAME AND COVER	401.000	CITY OF OTTAWA
SEWER TRENCH	S6	CITY OF OTTAWA
- STORM SEWER CATCHBASIN LEAD CONC 50.0 PVC DR 35
- ALL STORM AND SANITARY SERVICE LATERALS SHALL BE EQUIPPED WITH BACKFLOW PREVENTION DEVICES AS PER THE CITY OF OTTAWA STANDARDS DETAILS S14 AND S14.1 FOR OS-2.
- INSULATE ALL PIPES (SANITARY) THAT HAVE LESS THAN 1.8m COVER WITH H-40 INSULATION PER INSULATION DETAIL FOR SHALLOW SEWERS. PROVIDE 150mm CLEARANCE BETWEEN PIPE AND INSULATION.
- SEWERS ARE TO BE CONSTRUCTED TO 1.5m FROM FACE OF BUILDING AT A MINIMUM SLOPE OF 1.0%.
- PIPE BEDDING, COVER AND BACKFILL ARE TO BE COMPACTED TO AT LEAST 95% OF THE STANDARD PROCTOR MAXIMUM DRY DENSITY. THE USE OF CLEAR CRUSHED STONE AS A BEDDING LAYER SHALL NOT BE PERMITTED.
- FLEXIBLE CONNECTIONS ARE REQUIRED FOR CONNECTING PIPES TO MANHOLES (FOR EXAMPLE KOR-N-SEAL, PEX, POSITIVE SEAL AND DURASEAL). THE CONCRETE CHAMFER FOR THE PIPE CAN BE ELIMINATED.
- THE OWNER SHALL REQUIRE THAT THE SITE SERVICES CONTRACTOR PERFORM FIELD TESTS FOR QUALITY CONTROL OF ALL SANITARY SEWERS. LEAKAGE TESTING SHALL BE COMPLETED IN ACCORDANCE WITH OPSD 410.17.36, 410.17.36.1 AND 407.26. THE TESTING IS TO BE COMPLETED ON ALL SANITARY SEWERS TO CONFIRM PROPER CONNECTION TO THE SANITARY SEWER MAIN. THE FIELD TESTS SHALL BE PERFORMED IN THE PRESENCE OF A CERTIFIED PROFESSIONAL ENGINEER WHO SHALL SUBMIT A CERTIFIED COPY OF THE TEST RESULTS.
- ALL STORM MANHOLES AND CATCHBASIN MANHOLES ARE TO HAVE 300mm SUMP UNLESS OTHERWISE INDICATED. ALL CATCHBASINS ARE TO BE 600mm SQUARE UNLESS OTHERWISE INDICATED. ALL CATCHBASINS TO HAVE 3.0m OF FILTER-COARSED WRAPPED 100mm P/C PERFORATED SUBDRAIN IN AN UPDRAIN DIRECTION AND ALL ALONG THE PERIMETER OF THE CATCHBASIN LOT. PER GEOTECHNICAL RECOMMENDATIONS.
- ALL CATCHBASIN, MANHOLES AND/OR CATCHBASIN MANHOLES THAT ARE TO HAVE ICD'S INSTALLED WITHIN THEM ARE TO HAVE 600mm SUMPS.
- ALL KEEPING TILE CONNECTIONS TO BE MADE TO THE PROPOSED STORM SEWER SYSTEM DOWNSTREAM OF ANY INLET CONTROL DEVICES.
- CONTRACTOR TO TELEVISION (CCTV) ALL PROPOSED SEWERS, 200mm OR GREATER PRIOR TO BASE COURSE ASPHALT. UPON COMPLETION OF CONTRACT, THE CONTRACTOR IS RESPONSIBLE TO FLUSH AND CLEAN ALL SEWERS & APPURTENANCES.

BENCHMARK NOTES:

- ELEVATIONS SHOWN ARE GEODETIC AND ARE REFERRED TO THE CVD23 GEODETIC DATUM.
- IT IS THE RESPONSIBILITY OF THE USER OF THIS INFORMATION TO VERIFY THAT THE JOB BENCHMARK HAS NOT BEEN ALTERED OR DISTURBED AND THAT ITS RELATIVE ELEVATION AND DESCRIPTION AGREES WITH THE INFORMATION SHOWN ON THIS DRAWING.
- BENCHMARK WAS PROVIDED ON THE TOPOGRAPHIC PLAN OF SURVEY OF BLOCK 6 AND PART OF BLOCK 1 REGISTERED PLAN 4M-642 AND PART OF LOTS 2 AND 3 CONVEYANCE 4, GEODETIC TOWNSHIP OF MARCH, CITY OF OTTAWA, SURVEYED BY ANNIS, OSULLIVAN AND VOLEBEK LTD.

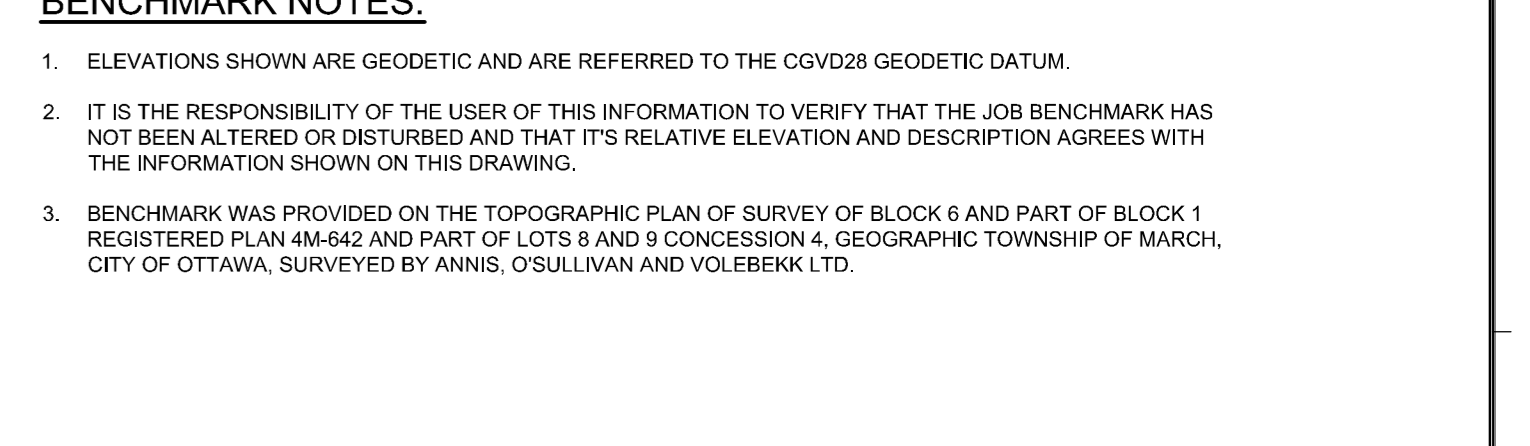

INLET CONTROL DEVICE DATA TABLE: AREA A-1 (INCL. AREAS OS-1 & OS-2)

DESIGN EVENT	ICD TYPE (STRUCTURE)	OUTLET DIAMETER (mm)	INLET DIAMETER (mm)	DESIGN HEAD (m)	DESIGN FLOW (L/s)	DESIGN WATER LEVEL (m)	DESIGN WATER STORAGE (m³)	AVAILABLE STORAGE (m³)
T2.9V	110mm DIA. ORFED FLOW ICD	375mm	375mm	0.82	258	81.70	152.4	1008.0
L3.0V	TYPE C2	375mm	375mm	0.82	258	81.70	152.4	1008.0

INLET CONTROL DEVICE DATA TABLE: AREA A-2 (POND)

DESIGN EVENT	ICD TYPE (STRUCTURE)	OUTLET DIAMETER (mm)	INLET DIAMETER (mm)	DESIGN HEAD (m)	DESIGN FLOW (L/s)	DESIGN WATER LEVEL (m)	DESIGN WATER STORAGE (m³)	AVAILABLE STORAGE (m³)
T2.9V	110mm DIA. ORFED FLOW ICD	375mm	375mm	0.82	258	81.70	152.4	1008.0
L3.0V	TYPE C2	375mm	375mm	0.82	258	81.70	152.4	1008.0

NOTE:
THE POSITION OF ALL POLE LINES, CONDUITS, WATERMANS, SEWERS AND OTHER UNDERGROUND AND OVERGROUND UTILITIES AND STRUCTURES IS NOT NECESSARILY SHOWN ON THE CONTRACT DRAWINGS, AND WHERE SHOWN, THE ACCURACY OF THE POSITION OF SUCH UTILITIES AND STRUCTURES IS NOT GUARANTEED. BEFORE STARTING WORK, DETERMINE THE EXACT LOCATION OF ALL SUCH UTILITIES AND STRUCTURES AND ASSUME ALL LIABILITY FOR DAMAGE TO THEM.

OWNER INFORMATION
NOKIA CO COLLIERS
181 BAY STREET, SUITE 1400
TORONTO, ONTARIO, M5J 2V1
ERIK CUNNINGTON
PHONE: (416) 920-0155
EMAIL: erik.cunnington@colliers.com

SURVEYOR
ANNIS, OSULLIVAN, VOLLEBEK LTD.
14 CONCOURSE GATE, SUITE 500
OTTAWA, ONTARIO, K2E 7S6
PHONE: (613) 727-0850

CIVIL ENGINEER/LANDSCAPE ARCHITECT
NOVATECH ENGINEERS, PLANNERS & LANDSCAPE ARCHITECTS
240 MICHAEL, COWPLAND DRIVE, SUITE 200
OTTAWA, ONTARIO, K2M 1M6
PHONE: (613) 254-9643

No.	REVISION	DATE	BY
3.	REVISED AS PER CITY COMMENTS	FEB 14/24	FST
2.	ISSUED FOR SPC APPROVAL	NOV 7/23	FST
1.	PRELIMINARY PLANS ISSUED TO CITY	OCT 29/23	FST

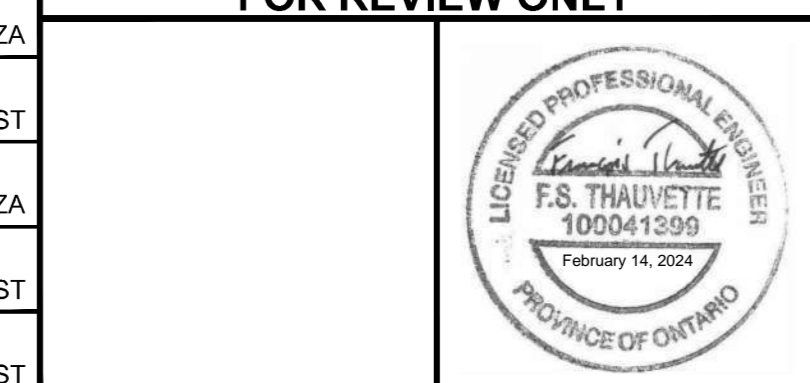

NOVATECH
Engineers, Planners & Landscape Architects
Suite 100, The 500
Ottawa, Ontario, Canada K2M 1P5
Telephone: (613) 254-9643
Fax: (613) 254-9887
Website: www.novatech-eng.com

PROFESSIONAL ENGINEER
F.S. TRAUWETTE
10034/1290
February 14, 2024
PROVINCE OF ONTARIO

LOCATION
CITY OF OTTAWA
600 MARCH ROAD - NOKIA PARKING LOT EXPANSION

DRAWING NAME
GENERAL PLAN OF SERVICES

PROJECT NO.
121334

REV.
REV #3

DRAWING NO.
121334-GP

PLAN #1907

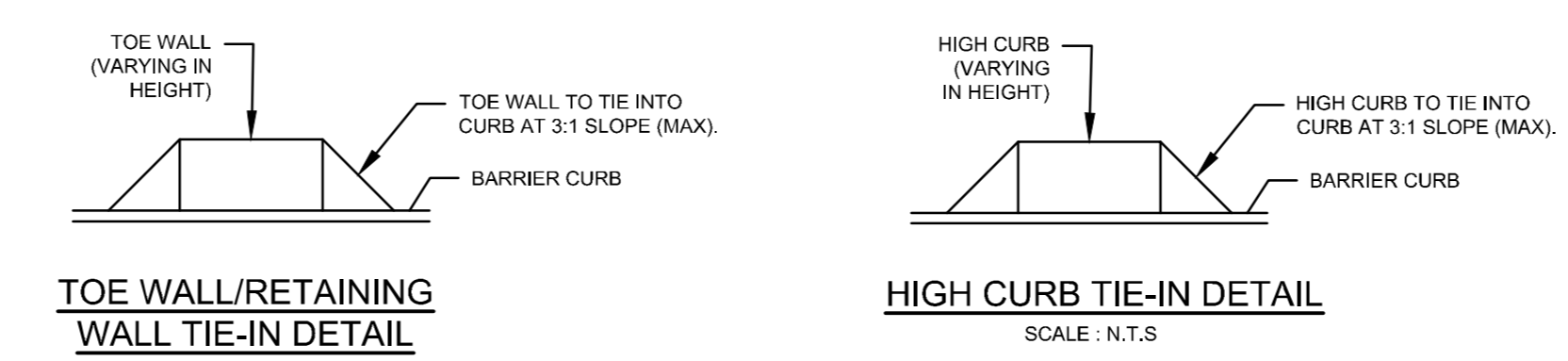
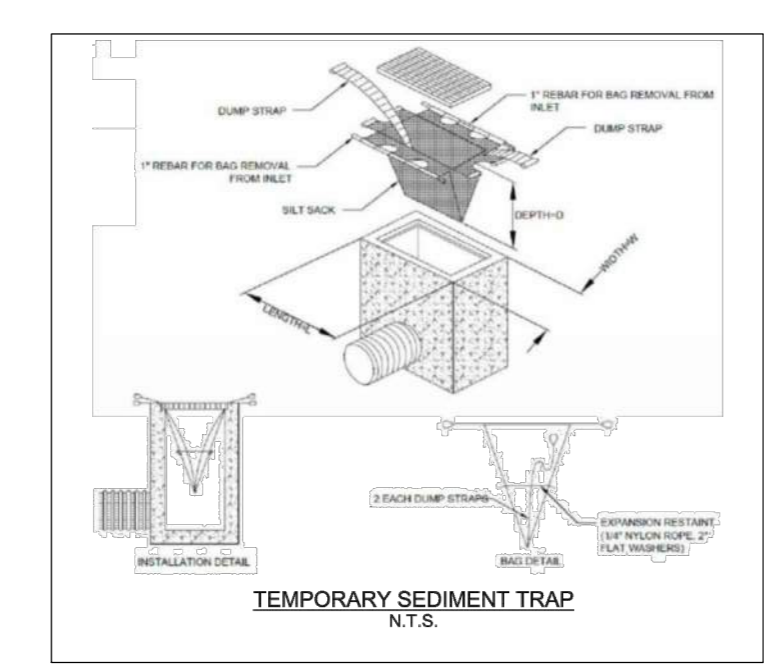
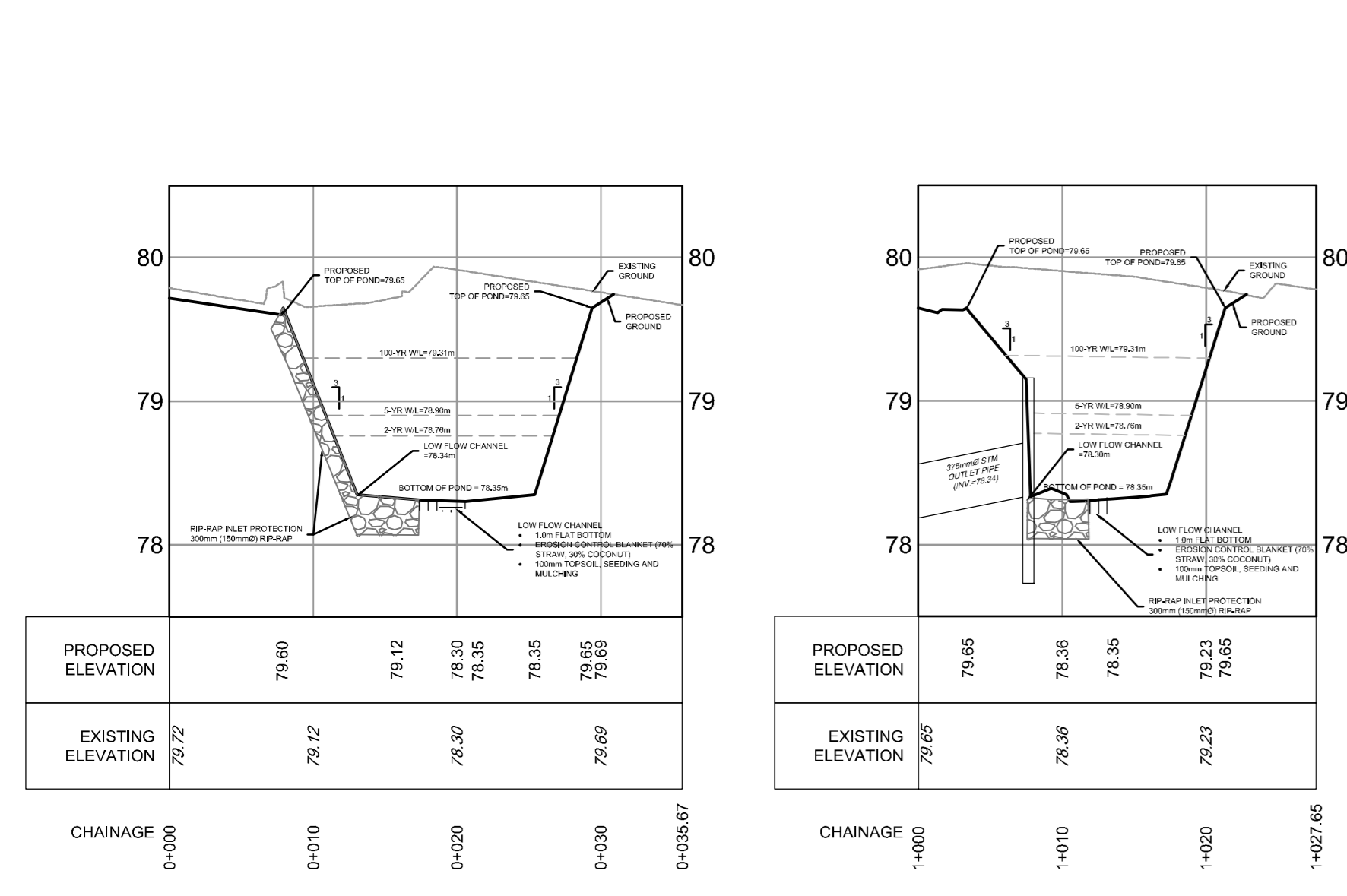

Erosion and Sediment Control Responsibilities									
ESC Measure	Symbol	Location	Responsible Contractor	Design Responsibility	Inspection Responsibility	Accepted by	Accepted by	Accepted by	Accepted by
Soil Paving	[Symbol]	OPSD 219-10	Overseer's Contract	Overseer's Contract	Weekly (as approved)	Consultant	Overseer's Contract	Nil	Nil
Filter Fabric	[Symbol]	OPSD 219-10	Overseer's Contract	Overseer's Contract	Weekly (as approved)	Consultant	Overseer's Contract	Nil	Nil
Mud Mat	[Symbol]	OPSD 219-10	Overseer's Contract	Overseer's Contract	Weekly (as approved)	Consultant	Overseer's Contract	Nil	Nil
Dual Curb	[Symbol]	OPSD 219-10	Overseer's Contract	Overseer's Contract	Weekly (as approved)	Consultant	Overseer's Contract	Nil	Nil
Soil Stabilization	[Symbol]	OPSD 219-10	Overseer's Contract	Overseer's Contract	Weekly (as approved)	Consultant	Overseer's Contract	Nil	Nil
Soil Nails	[Symbol]	OPSD 219-10	Overseer's Contract	Overseer's Contract	Weekly (as approved)	Consultant	Overseer's Contract	Nil	Nil
Soil Anchors	[Symbol]	OPSD 219-10	Overseer's Contract	Overseer's Contract	Weekly (as approved)	Consultant	Overseer's Contract	Nil	Nil
Soil Reinforcement	[Symbol]	OPSD 219-10	Overseer's Contract	Overseer's Contract	Weekly (as approved)	Consultant	Overseer's Contract	Nil	Nil
Soil Erosion Control	[Symbol]	OPSD 219-10	Overseer's Contract	Overseer's Contract	Weekly (as approved)	Consultant	Overseer's Contract	Nil	Nil
Soil Stabilization	[Symbol]	OPSD 219-10	Overseer's Contract	Overseer's Contract	Weekly (as approved)	Consultant	Overseer's Contract	Nil	Nil

POND CROSS-SECTION A-A
SCALE: 1:40 (H) / 1:40 (V)

POND CROSS-SECTION B-B
SCALE: 1:40 (H) / 1:40 (V)

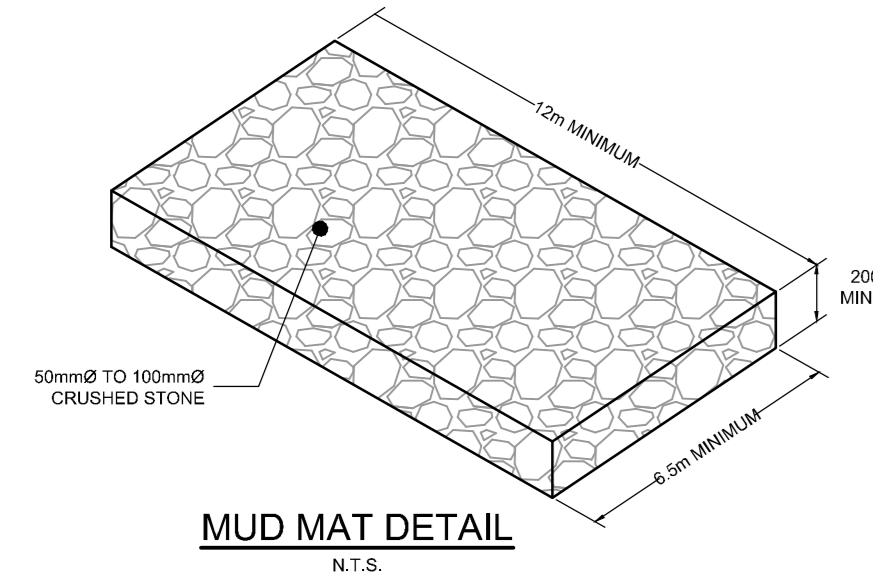

MUD MAT DETAIL
SCALE: N.T.S.

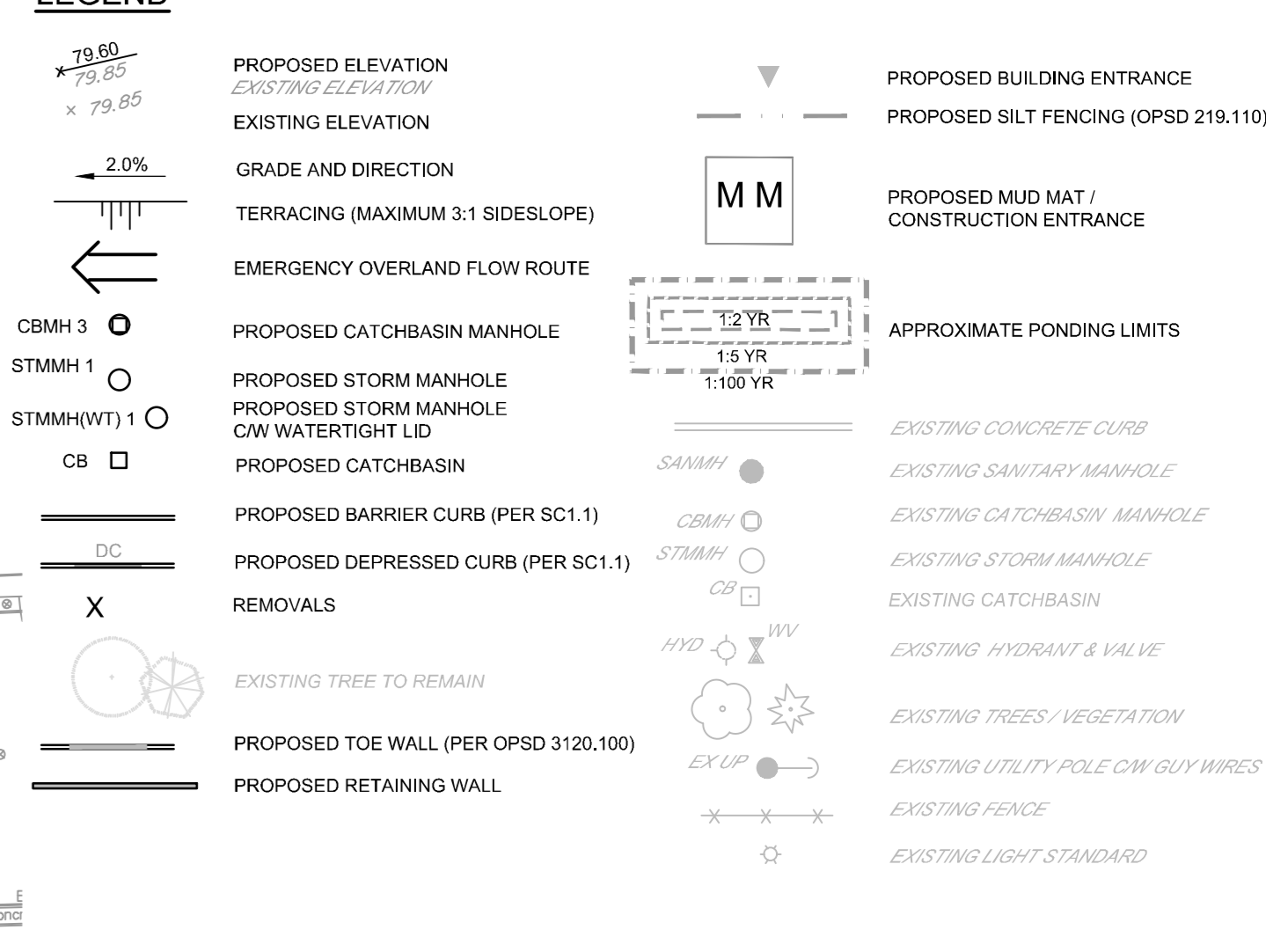
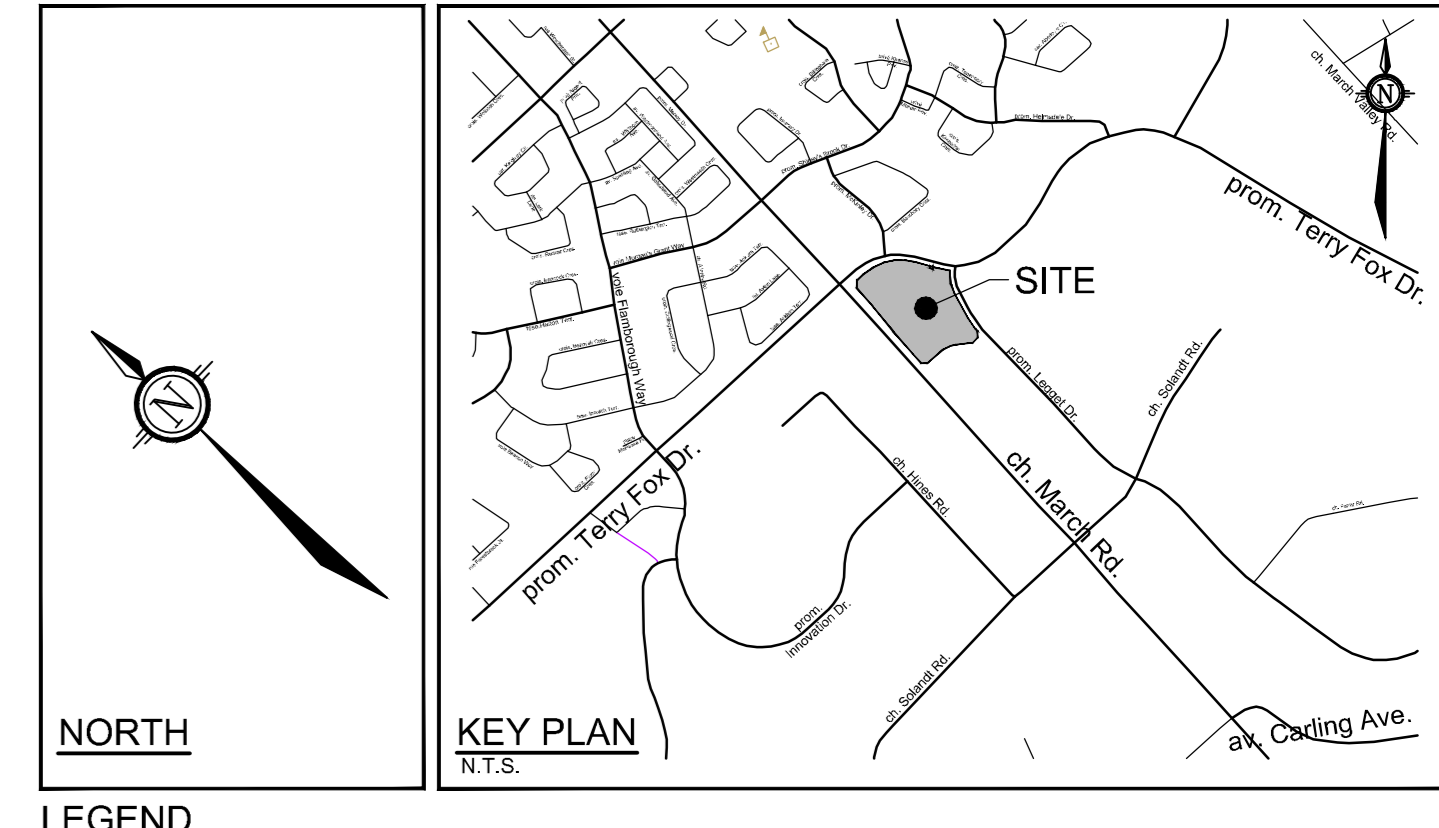
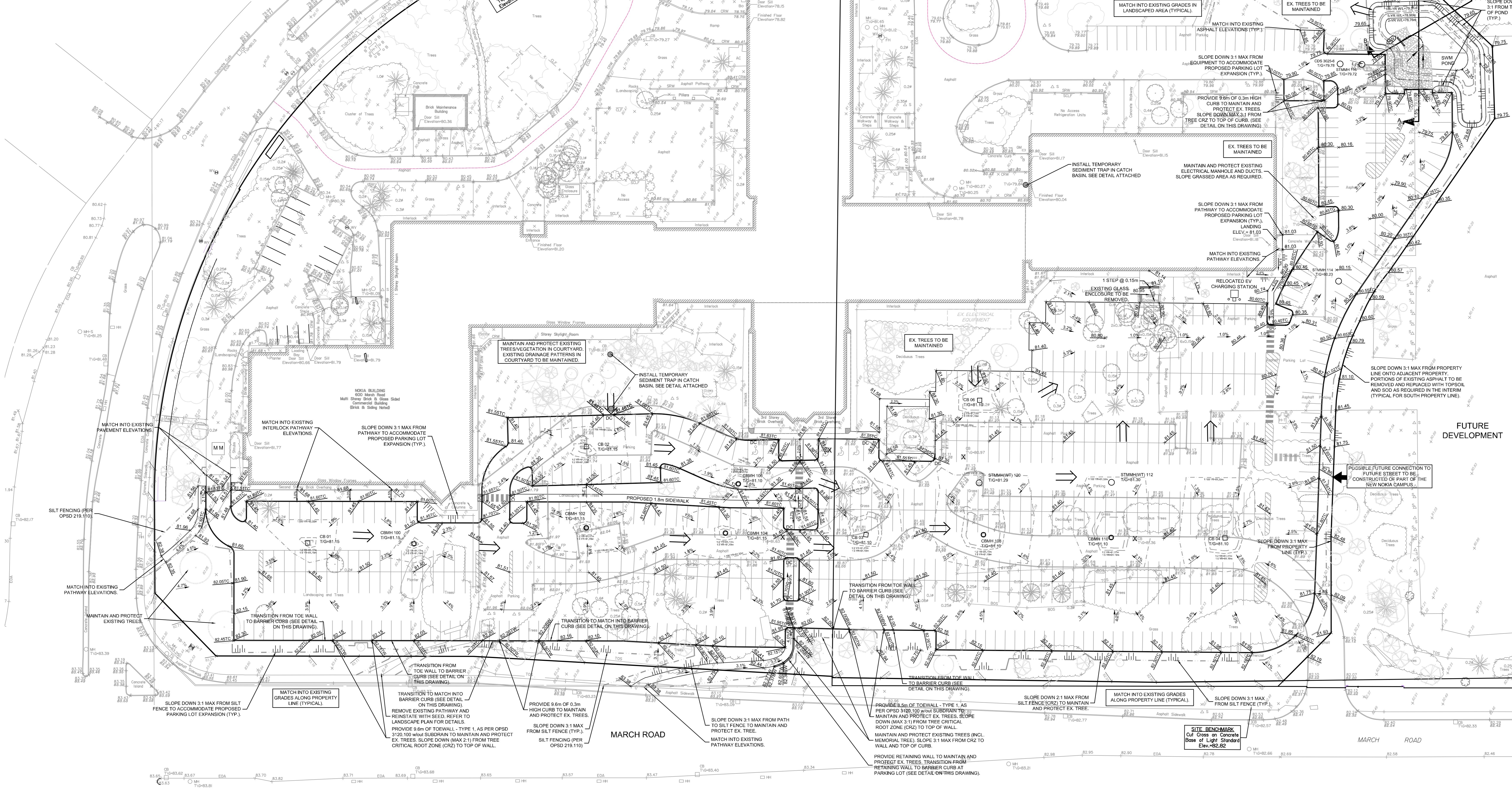

- GENERAL NOTES:**
- COORDINATE AND SCHEDULE ALL WORK WITH OTHER TRADES AND CONTRACTORS.
 - DETERMINE THE EXACT LOCATION, SIZE, MATERIAL AND ELEVATION OF ALL EXISTING UTILITIES PRIOR TO COMMENCING CONSTRUCTION. PROTECT AND ASSUME RESPONSIBILITY FOR ALL EXISTING UTILITIES WHETHER OR NOT SHOWN ON THIS DRAWING.
 - OBTAIN ALL NECESSARY PERMITS AND APPROVALS FROM THE CITY OF OTTAWA BEFORE COMMENCING CONSTRUCTION.
 - BEFORE COMMENCING CONSTRUCTION OBTAIN AND PROVIDE PROOF OF COMPREHENSIVE ALL RISK AND OPERATIONAL LIABILITY INSURANCE FOR \$5,000,000.00. INSURANCE POLICY TO NAME OWNERS, ENGINEERS AND ARCHITECTS AS CO-INSURED.
 - RESTORE ALL DISTURBED AREAS ON-SITE AND OFF-SITE, INCLUDING TRENCHES AND SURFACES ON PUBLIC ROAD ALLOWANCES TO EXISTING CONDITIONS OR BETTER TO THE SATISFACTION OF THE CITY OF OTTAWA AND ENGINEER.
 - REMOVE FROM SITE ALL EXCESS EXCAVATED MATERIAL, ORGANIC MATERIAL AND DEBRIS UNLESS OTHERWISE INSTRUCTED BY ENGINEER. EXCAVATE AND REMOVE FROM SITE ANY CONTAMINATED MATERIAL. ALL CONTAMINATED MATERIAL SHALL BE DISPOSED OF AT A LICENSED LANDFILL FACILITY.
 - ALL ELEVATIONS ARE GEODETIC.
 - REFER TO THE GEOTECHNICAL INVESTIGATION AND HYDROGEOLOGICAL ASSESSMENT - 600 MARCH ROAD - (REPORT NO. 1008787-1) DATED ON JUNE 16, 2023, FOR SUBSURFACE CONDITIONS, PROPOSED CONSTRUCTION RECOMMENDATIONS AND GEOTECHNICAL INSPECTION REQUIREMENTS. THE GEOTECHNICAL CONSULTANT IS TO REVIEW ON-SITE CONDITIONS AFTER EXCAVATION PRIOR TO PLACEMENT OF THE GRANULAR MATERIAL.
 - REFER TO ARCHITECTS AND LANDSCAPE ARCHITECTS DRAWINGS FOR BUILDING AND HARD SURFACE AREAS AND DIMENSIONS.
 - REFER TO STORMWATER MANAGEMENT REPORT (R-2023-143) PREPARED BY NOVATECH ENGINEERING CONSULTANTS LTD.
 - SAW CUT AND KEY GRIND ASPHALT AT ALL ROAD CUTS AND ASPHALT IN THE POINTS AS PER CITY OF OTTAWA STANDARDS (R10).
 - PROVIDE LINE/PARKING PAINTING.

- GRADING NOTES:**
- ALL TOPSOIL, ORGANIC OR DELETERIOUS MATERIAL MUST BE ENTIRELY REMOVED FROM BENEATH THE PROPOSED PAVED AREAS AS DIRECTED BY THE SITE ENGINEER OR GEOTECHNICAL ENGINEER.
 - EXPOSED SUBGRADES IN PROPOSED PAVED AREAS SHOULD BE PROOF ROLLED WITH A LARGE STEEL DRUM ROLLER AND INSPECTED BY THE GEOTECHNICAL ENGINEER PRIOR TO THE PLACEMENT OF GRANULARS.
 - ANY SOFT AREAS EVIDENT FROM THE PROOF ROLLING SHOULD BE SUB-EXCAVATED AND REPLACED WITH SUITABLE MATERIAL THAT IS PROST COMPATIBLE WITH THE EXISTING SOILS AS RECOMMENDED BY THE GEOTECHNICAL ENGINEER.
 - THE GRANULAR BASE SHOULD BE COMPACTED TO AT LEAST 100% OF THE STANDARD PROCTOR MAXIMUM DRY DENSITY VALUE. ANY ADDITIONAL GRANULAR FILL USED BELOW THE PROPOSED PAVEMENT SHOULD BE COMPACTED TO AT LEAST 90% OF THE STANDARD PROCTOR MAXIMUM DRY DENSITY VALUE.
 - MINIMUM OF 2% GRADE FOR ALL GRASS AREAS UNLESS OTHERWISE NOTED.
 - MAXIMUM TERRACING GRADE TO BE 3:1 UNLESS OTHERWISE NOTED.
 - ALL GRADES BY CURBS ARE EDGE OF PAVEMENT GRADES UNLESS OTHERWISE INDICATED.
 - ALL CURBS SHALL BE BARRIER CURB (150mm) UNLESS OTHERWISE NOTED AND CONSTRUCTED AS PER CITY OF OTTAWA STANDARDS (SC1.1). MOUNTABLE CURBS ARE TO BE PER CITY OF OTTAWA STANDARD (SC1.3).
 - REFER TO LANDSCAPE PLAN FOR PLANTING AND OTHER LANDSCAPE FEATURE DETAILS.
 - CONTRACTOR TO PROVIDE THE CONSULTANT WITH A GRADING PLAN INDICATING AS-BUILT ELEVATIONS OF ALL DESIGN GRADES SHOWN ON THIS PLAN.

- EROSION AND SEDIMENT CONTROL NOTES:**
- THE CONTRACTOR SHALL IMPLEMENT BEST MANAGEMENT PRACTICES, TO PROVIDE PROTECTION OF THE AREA DRAINAGE SYSTEM AND THE RECEIVING WATER COURSE, DURING CONSTRUCTION ACTIVITIES. THE CONTRACTOR ACKNOWLEDGES THAT FAILURE TO IMPLEMENT APPROPRIATE EROSION AND SEDIMENT CONTROL MEASURES MAY BE SUBJECT TO PENALTIES IMPOSED BY ANY APPLICABLE REGULATORY AGENCY.
 - ALL EROSION AND SEDIMENT CONTROLS ARE TO BE INSTALLED TO THE SATISFACTION OF THE ENGINEER AND THE CITY OF OTTAWA. THEY ARE TO BE APPROPRIATE TO THE SITE CONDITIONS, PRIOR TO UNDERTAKING ANY SITE ALTERATIONS (FILLING, GRADING, REMOVAL OF EXISTING MATERIAL, ETC.) AND DURING ALL PHASES OF SITE PREPARATION AND CONSTRUCTION. THESE PRACTICES ARE TO BE IMPLEMENTED IN ACCORDANCE WITH THE CURRENT BEST MANAGEMENT PRACTICES FOR EROSION AND SEDIMENT CONTROL. THESE MEASURES SHOULD INCLUDE A MINIMUM THOSE MEASURES INDICATED ON THIS PLAN.
 - EROSION AND SEDIMENT CONTROL MEASURES WILL BE IMPLEMENTED DURING BEST MANAGEMENT PRACTICES IN ACCORDANCE WITH THE "GUIDELINES ON EROSION AND SEDIMENT CONTROL FOR URBAN CONSTRUCTION SITES" (GOVERNMENT OF ONTARIO, MAY 1987). THE CONTRACTOR SHALL BE SOLELY RESPONSIBLE FOR MEETING ALL REGULATORY AGENCY REQUIREMENTS.
 - TO PREVENT SURFACE EROSION FROM ENTERING ANY STORM SEWER DURING CONSTRUCTION, FILTER CLOTH WILL BE PLACED UNDER GRATES OF NEARBY CATCHBASINS AND STRUCTURES. A LIGHT DUTY SILT FENCE BARRIER WILL ALSO BE INSTALLED AROUND THE CONSTRUCTION AREA (WHERE APPLICABLE). THESE CONTROL MEASURES WILL REMAIN IN PLACE UNTIL CONSTRUCTION IS COMPLETE.
 - TO LIMIT EROSION MINIMIZE THE AMOUNT OF EXPOSED SOILS AT ANY GIVEN TIME. REVEGETATE EXPOSED AREAS AND SLOPES AS SOON AS POSSIBLE AND PROTECT EXPOSED SLOPES WITH NATURAL OR SYNTHETIC MULCHES.
 - FOR MATERIAL STOCKPILING MINIMIZE THE AMOUNT OF EXPOSED MATERIALS AT ANY GIVEN TIME. APPLY TEMPORARY SEEDING, TAPPS, CONSTRUCTION AND/OR SURFACE ROUGHENING AS REQUIRED TO STABILIZE STOCKPILED MATERIALS THAT WILL NOT BE USED WITHIN 14 DAYS.
 - THE SEDIMENT CONTROL MEASURES SHALL ONLY BE REMOVED WHEN, IN THE OPINION OF THE ENGINEER, THE MEASURES ARE NO LONGER REQUIRED. NO CONTROL MEASURES MAY BE PERMANENTLY REMOVED WITHOUT PRIOR AUTHORIZATION FROM THE ENGINEER.
 - THE CONTRACTOR SHALL IMMEDIATELY REPORT TO THE ENGINEER ANY ACCIDENTAL DISCHARGES OF SEDIMENT MATERIAL INTO ANY STORM SEWER. IMMEDIATE REPORTING MEASURES, INCLUDING ANY REMEDIATION TO CONTROL CONTAMINATION, AND CONSTRUCTION ACTIVITIES, AND WHEN DUST LEVELS BECOME VISUALLY APPARENT SPRAY WATER TO MINIMIZE THE RELEASE OF DUST FROM GRAVEL, PAVED AREAS AND EXPOSED SOILS. USE CHEMICAL DUST SUPPRESSANTS ONLY WHERE NECESSARY ON PROBLEM AREAS.
 - THE CONTRACTOR ACKNOWLEDGES THAT FAILURE TO IMPLEMENT EROSION AND SEDIMENT CONTROL MEASURES MAY BE SUBJECT TO PENALTIES IMPOSED BY ANY APPLICABLE REGULATORY AGENCY.
 - ROADWAYS ARE TO BE SWEEP AS REQUIRED OR AS DIRECTED BY THE ENGINEER AND/OR THE MUNICIPALITY.
 - THE CONTRACTOR SHALL ENSURE PROPER DUST CONTROL IS PROVIDED WITH THE APPLICATION OF WATER AND IF REQUIRED, CALCIUM CHLORIDE DURING DRY PERIODS. MONITOR DUST LEVELS DURING SITE PREPARATION, CONSTRUCTION, AND CONSTRUCTION ACTIVITIES, AND WHEN DUST LEVELS BECOME VISUALLY APPARENT SPRAY WATER TO MINIMIZE THE RELEASE OF DUST FROM GRAVEL, PAVED AREAS AND EXPOSED SOILS. USE CHEMICAL DUST SUPPRESSANTS ONLY WHERE NECESSARY ON PROBLEM AREAS.

- BENCHMARK NOTES:**
- ELEVATIONS SHOWN ARE GEODETIC AND ARE REFERRED TO THE CGVD28 GEODETIC DATUM.
 - IT IS THE RESPONSIBILITY OF THE USER OF THIS INFORMATION TO VERIFY THAT THE JOB BENCHMARK HAS NOT BEEN ALTERED OR DISTURBED AND THAT ITS RELATIVE ELEVATION AND DESCRIPTION AGREES WITH THE INFORMATION SHOWN ON THIS DRAWING.
 - BENCHMARK WAS PROVIDED ON THE TOPOGRAPHIC PLAN OF SURVEY OF BLOCK 8 AND PART OF BLOCK 1 REGISTERED PLAN 4M462 AND PART OF LOTS 8 AND 5 CONCESSION 4, GEOTECHNICAL TOWNSHIP OF MARCH, CITY OF OTTAWA, SURVEYED BY ANIS, OSULLIVAN AND VOLSEK LTD.

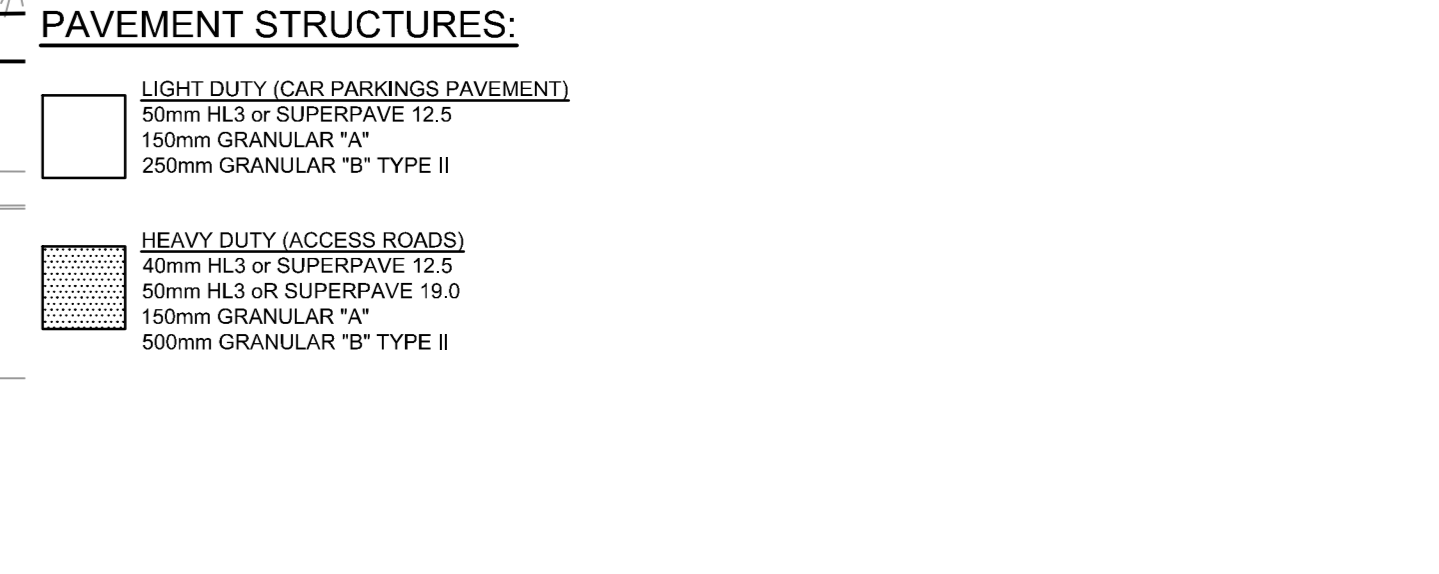

NOTE:
THE POSITION OF ALL POLE LINES, CONDUITS, WATERMANS, SEWERS AND OTHER UNDERGROUND AND OVERGROUND UTILITIES AND STRUCTURES IS NOT NECESSARILY SHOWN ON THE CONTRACT DRAWINGS, AND WHERE SHOWN, THE ACCURACY OF THE POSITION OF SUCH UTILITIES AND STRUCTURES IS NOT GUARANTEED. BEFORE STARTING WORK, DETERMINE THE EXACT LOCATION OF ALL SUCH UTILITIES AND STRUCTURES AND ASSUME ALL LIABILITY FOR DAMAGE TO THEM.

OWNER INFORMATION
NOKIA CO COLLIERS
181 BAY STREET, SUITE 1400
TORONTO, ONTARIO, M5J 2V1
ERIK CUNNINGTON
PHONE: (416) 920-0155
EMAIL: erik.cunnington@colliers.com

SURVEYOR
ANNIS, OSULLIVAN, VOLLEBECK LTD.
14 CONCORSE GATE, SUITE 500
OTTAWA, ONTARIO, K2E 7S6
PHONE: (613) 727-0850

CIVIL ENGINEER/LANDSCAPE ARCHITECT
NOVATECH ENGINEERS, PLANNERS & LANDSCAPE ARCHITECTS
240 MICHAEL, COWPLAND DRIVE, SUITE 200
OTTAWA, ONTARIO, K2M 1P6
PHONE: (613) 254-9643

No.	REVISION	DATE	BY
3.	REVISED AS PER CITY COMMENTS	FEB 14/24	FST
2.	ISSUED FOR SPC APPROVAL	NOV 7/23	FST
1.	PRELIMINARY PLANS ISSUED TO CITY	OCT 20/23	FST

SCALE	DATE	BY
1:400		

FOR REVIEW ONLY

LOCATION
CITY OF OTTAWA
600 MARCH ROAD - NOKIA PARKING LOT EXPANSION

DRAWING NAME
GRADING PLAN AND EROSION & SEDIMENT CONTROL PLAN

PROJECT NO.
121334-GR

REV #
REV 3

DATE
12/13/23

NOVATECH
Engineers, Planners & Landscape Architects
Suite 200, 140 Michael Cowpland Drive
Ottawa, Ontario, Canada K2M 1P6
Telephone: (613) 254-9643
Fax: (613) 254-9887
Website: www.novatech-eng.com

REGISTERED PROFESSIONAL ENGINEER
F.S. THALVETTE
1000411029
PROVINCE OF ONTARIO



LEGEND

	DRAINAGE AREA LIMITS
	PRE-DEVELOPMENT AREA ID
	PRE-DEVELOPMENT DRAINAGE AREA (ha)
	1.5 YEAR WEIGHTED RUNOFF COEFFICIENT
	EXISTING STORMWATER & SEWER
	EXISTING CATCHBASIN
	EXISTING CONCRETE CURB
	EXISTING VALVE & VALVE BOX
	EXISTING SERVICE POST
	EXISTING HYDRANT
	EXISTING CATCHBASIN
	EXISTING CATCHBASIN
	EXISTING UTILITY POLE
	EXISTING UTILITY POLE

- GENERAL NOTES:**
- COORDINATE AND SCHEDULE ALL WORK WITH OTHER TRADES AND CONTRACTORS.
 - DETERMINE THE EXACT LOCATION, SIZE, MATERIAL AND ELEVATION OF ALL EXISTING UTILITIES PRIOR TO COMMENCING CONSTRUCTION. PROTECT AND ASSUME RESPONSIBILITY FOR ALL EXISTING UTILITIES WHETHER OR NOT SHOWN ON THIS DRAWING.
 - OBTAIN ALL NECESSARY PERMITS AND APPROVALS FROM THE CITY OF OTTAWA BEFORE COMMENCING CONSTRUCTION.
 - BEFORE COMMENCING CONSTRUCTION OBTAIN AND PROVIDE PROOF OF COMPREHENSIVE, ALL RISK AND OPERATIONAL LIABILITY INSURANCE FOR \$5,000,000.00. INSURANCE POLICY TO NAME OWNERS, ENGINEERS AND ARCHITECTS AS CO-INSURED.
 - COMPLETE ALL WORKS IN ACCORDANCE WITH THE MOST CURRENT CITY OF OTTAWA STANDARDS AND SPECIFICATIONS USING THE CURRENT GUIDELINES, BYLAWS AND STANDARDS INCLUDING MATERIALS OF CONSTRUCTION, DIMENSION AND ALL RELEVANT REFERENCES TO OPCS, OPCS & WWW GUIDELINES, ALL CURRENT VERSIONS AND AS AMENDED.
 - RESTORE ALL DISTURBED AREAS ON-SITE AND OFF-SITE, INCLUDING TRENCHES AND SURFACES ON PUBLIC ROAD ALLOWANCES TO EXISTING CONDITIONS OR BETTER TO THE SATISFACTION OF THE CITY OF OTTAWA AND ENGINEER.
 - REMOVE FROM SITE ALL EXCESS EXCAVATED MATERIAL, ORGANIC MATERIAL AND DEBRIS UNLESS OTHERWISE INSTRUCTED BY ENGINEER. EXCAVATE AND REMOVE FROM SITE ANY CONTAMINATED MATERIAL. ALL CONTAMINATED MATERIAL SHALL BE DISPOSED OF AT A LICENSED LANDFILL FACILITY.
 - ALL ELEVATIONS ARE GEODETIC.
 - REFER TO THE GEOTECHNICAL INVESTIGATION AND HYDROGEOLOGICAL ASSESSMENT - 600 MARCH ROAD - (REPORT NO. 1206873-RPT-1), PREPARED BY GHD ON JUNE 16, 2023. FOR SUBSURFACE CONDITIONS, CONSTRUCTION RECOMMENDATIONS, AND GEOTECHNICAL INSPECTION REQUIREMENTS, THE GEOTECHNICAL CONSULTANT IS TO REVIEW ON-SITE CONDITIONS AFTER EXCAVATION PRIOR TO PLACEMENT OF THE GRANULAR MATERIAL.
 - REFER TO ARCHITECTS AND LANDSCAPE ARCHITECTS DRAWINGS FOR BUILDING AND HARDSURFACE AREAS AND DIMENSIONS.
 - REFER TO THE STORMWATER MANAGEMENT REPORT (R-2023-143) PREPARED BY NOVATECH.
 - SAW CUT AND KEY GRIND ASPHALT AT ALL ROAD CUTS AND ASPHALT TIE IN POINTS AS PER CITY OF OTTAWA STANDARDS (R10).

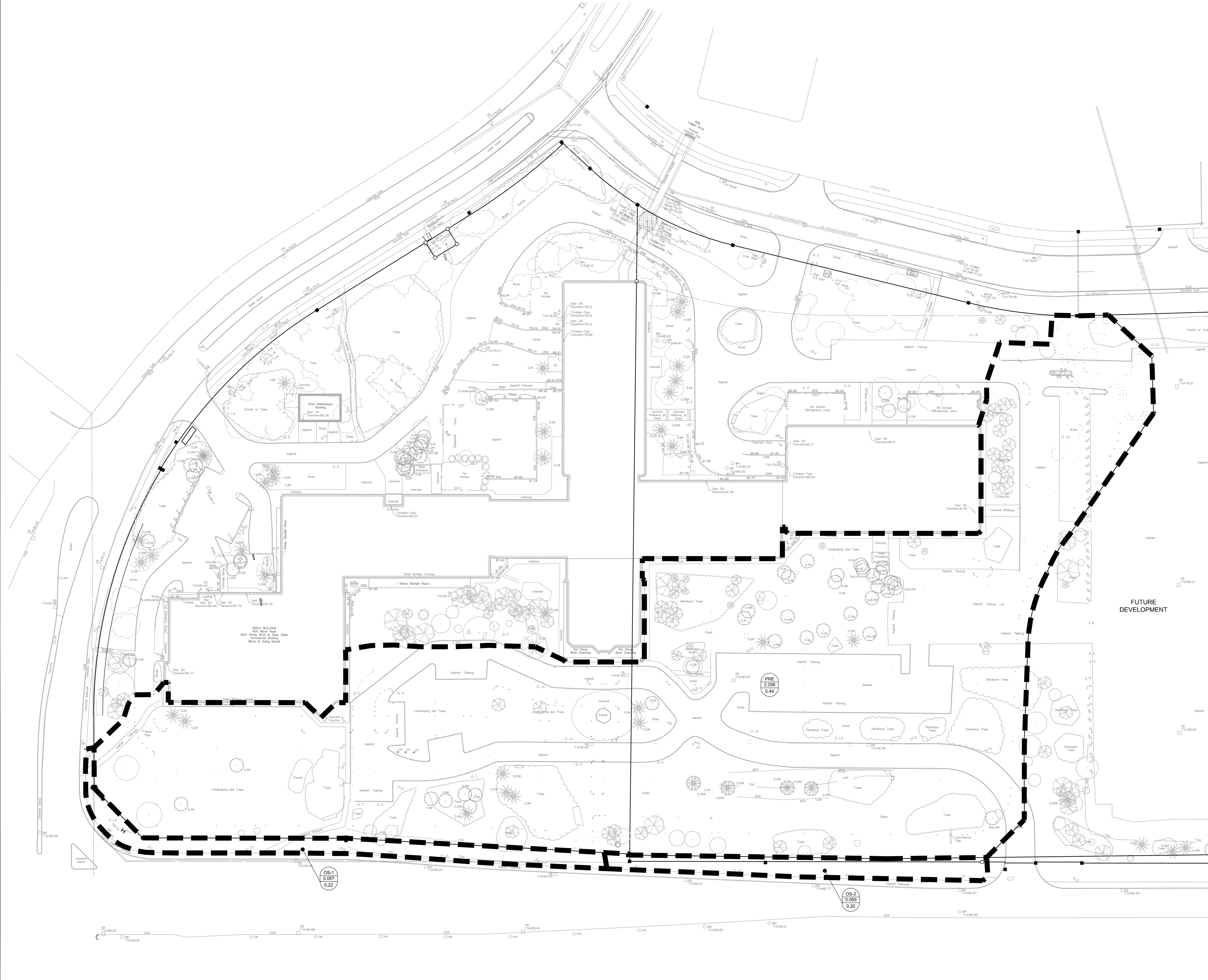

NOTE:
THE POSITION OF ALL POLE LINES, CONDUITS, WATERMANS, SEWERS AND OTHER UNDERGROUND AND OVERGROUND UTILITIES AND STRUCTURES IS NOT NECESSARILY SHOWN ON THE CONTRACT DRAWINGS, AND WHERE SHOWN, THE ACCURACY OF THE POSITION OF SUCH UTILITIES AND STRUCTURES IS NOT GUARANTEED. BEFORE STARTING WORK, DETERMINE THE EXACT LOCATION OF ALL SUCH UTILITIES AND STRUCTURES AND ASSUME ALL LIABILITY FOR DAMAGE TO THEM.

OWNER INFORMATION
NOKIA CO COLLIERS
181 BAY STREET, SUITE 1400
TORONTO, ONTARIO, M5J 2V1
ERIK CUNNINGTON
PHONE: (416) 920-0155
EMAIL: erik.cunnington@colliers.com

SURVEYOR
ANNIS, O'SULLIVAN, VOLLEBECK LTD.
14 CONCORSE GATE, SUITE 500
OTTAWA, ONTARIO, K2M 1P6
PHONE: (613) 727-0850

CIVIL ENGINEER/LANDSCAPE ARCHITECT
NOVATECH ENGINEERS, PLANNERS & LANDSCAPE ARCHITECTS
240 MICHAEL COWPLAND DRIVE, SUITE 200
OTTAWA, ONTARIO, K2M 1P6
PHONE: (613) 254-9643

NO.	REVISION	DATE	BY
1.	REVISED AS PER CITY COMMENTS	FEB 14/24	FST

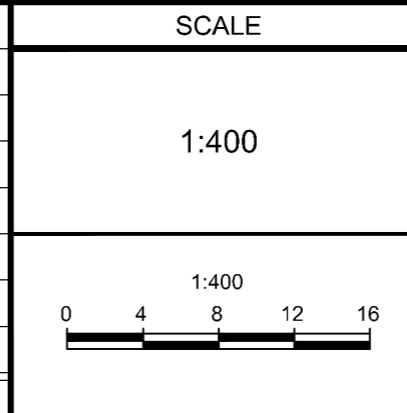

FOR REVIEW ONLY	DATE	BY
CHECKED		CV
DRAWN		FST
CHECKED		CV
APPROVED		FST



NOVATECH
Engineers, Planners & Landscape Architects
Suite 200, 340 Michael Cowpland Drive
Ottawa, Ontario, Canada K2M 1P6
Telephone: (613) 254-9643
Facsimile: (613) 254-9887
Website: www.novatech-eng.com

LOCATION
CITY OF OTTAWA
600 MARCH ROAD - NOKIA PARKING LOT EXPANSION

DRAWING NAME
PRE-DEVELOPMENT
STORMWATER DRAINAGE PLAN

PROJECT NO.: 121334
REV # 1
DRAWING NO.: 121334-STM
PLAN # 1907

NOVATECH ENGINEERS, PLANNERS & LANDSCAPE ARCHITECTS, 3710, 15, 15, 2024, 1:50pm, 1:50pm, 1:50pm

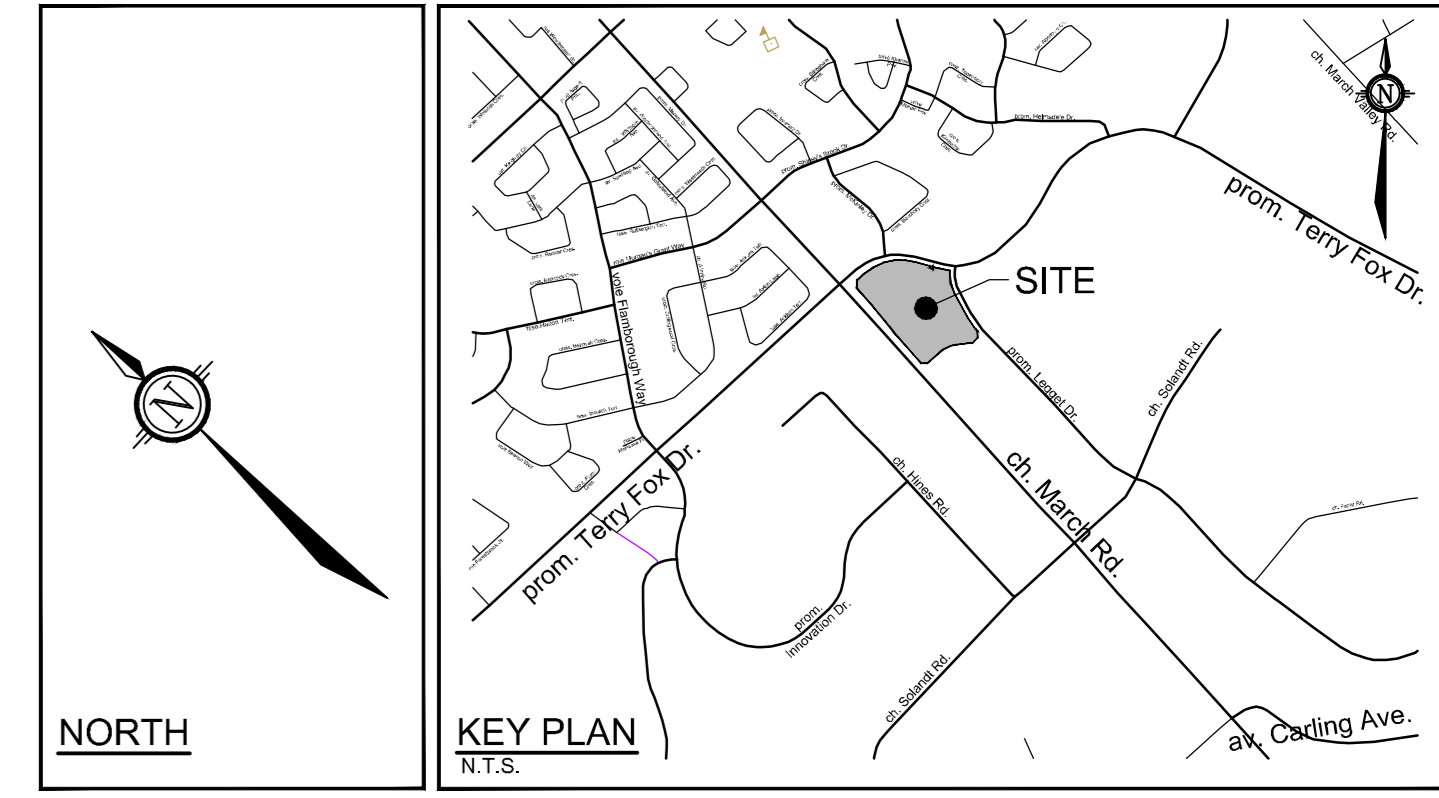
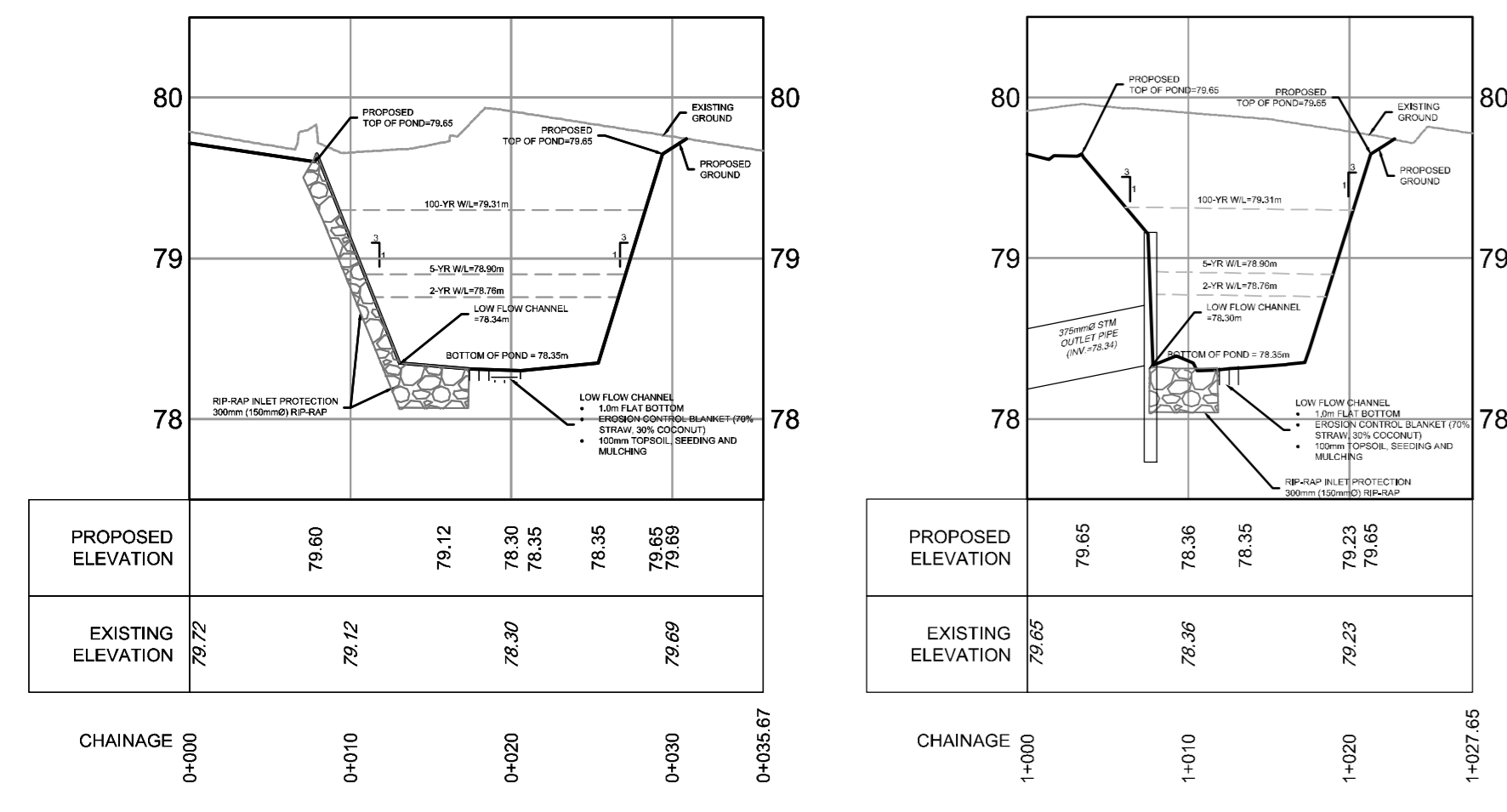

- LEGEND**
- PROPOSED BARRIER CURB
 - PROPOSED DEPRESSION CURB
 - DRAINAGE AREA LIMITS
 - APPROXIMATE PONDING LIMITS
 - POST-DEVELOPMENT AREA ID
 - POST-DEVELOPMENT DRAINAGE AREA (HA)
 - 1.5 YEAR WEIGHTED RUNOFF COEFFICIENT
 - PROPOSED STORM MANHOLE & SEWER (WT-WATER TIGHT COVER)
 - PROPOSED STORM MANHOLE & SEWER (WT-WATER TIGHT COVER)
 - PROPOSED CATCH BASIN
 - PROPOSED STORM SEWER AND FLOW DIRECTION
 - PROPOSED INLET CONTROL DEVICE
 - EMERGENCY OVERLAND FLOW ROUTE
 - MAXIMUM 3:1 SIDESLOPE
 - FINISHED FLOOR ELEVATION
 - UNDERSIDE OF FOOTING ELEVATION
 - EXISTING CATCH BASIN
 - EXISTING CATCH BASIN LEAD
 - EXISTING CONCRETE CURB
 - EXISTING VALVE & HUBLE BOX
 - EXISTING SERVICE PASS
 - EXISTING HYDRANT
 - EXISTING GAS CATCH BASIN
 - EXISTING GAS CATCH BASIN LEAD
 - EXISTING UTILITY POLE
 - EXISTING MANHOLE

- GENERAL NOTES:**
- COORDINATE AND SCHEDULE ALL WORK WITH OTHER TRADES AND CONTRACTORS.
 - DETERMINE THE EXACT LOCATION, SIZE, MATERIAL AND ELEVATION OF ALL EXISTING UTILITIES PRIOR TO COMMENCING CONSTRUCTION. PROTECT AND ASSUME RESPONSIBILITY FOR ALL EXISTING UTILITIES WHETHER OR NOT SHOWN ON THIS DRAWING.
 - OBTAIN ALL NECESSARY PERMITS AND APPROVALS FROM THE CITY OF OTTAWA BEFORE COMMENCING CONSTRUCTION.
 - BEFORE ANY CONSTRUCTION WORK BEGINS PROVIDE PROOF OF COMPREHENSIVE ALL RISK AND OPERATIONAL LIABILITY INSURANCE FOR \$5,000,000.00. INSURANCE POLICY TO NAME OWNERS, ENGINEERS AND ARCHITECTS AS CO-INSURED.
 - COMPLETE ALL WORKS IN ACCORDANCE WITH THE MOST CURRENT CITY OF OTTAWA STANDARDS AND SPECIFICATIONS USING THE CURRENT GUIDELINES BY LAWS AND STANDARDS INCLUDING MATERIALS OF CONSTRUCTION, DIMENSION AND ALL RELEVANT REFERENCES TO OSSL, OPS & WMAV GUIDELINES. ALL CURRENT VERSIONS AND AS AMENDED.
 - RESTORE ALL DISTURBED AREAS ON-SITE AND OFF-SITE, INCLUDING TRENCHES AND SURFACES ON PUBLIC ROAD ALLOWANCES TO EXISTING CONDITIONS OR BETTER TO THE SATISFACTION OF THE CITY OF OTTAWA AND ENGINEER.
 - REMOVE FROM SITE ALL EXCESS EXCAVATED MATERIAL, ORGANIC MATERIAL AND DEBRIS UNLESS OTHERWISE INSTRUCTED BY ENGINEER. EXCAVATE AND REMOVE FROM SITE ANY CONTAMINATED MATERIAL. ALL CONTAMINATED MATERIAL SHALL BE DISPOSED OF AT A LICENSED LANDFILL FACILITY.
 - ALL ELEVATIONS ARE GEODETIC.
 - REFER TO THE GEOTECHNICAL INVESTIGATION AND HYDROGEOLOGICAL ASSESSMENT - 600 MARCH ROAD - (REPORT NO. 1206873-RPT-1), PREPARED BY GHD ON JUNE 16, 2023. FOR SUBSURFACE CONDITIONS, CONSTRUCTION RECOMMENDATIONS, AND GEOTECHNICAL INSPECTION REQUIREMENTS. THE GEOTECHNICAL CONSULTANT IS TO REVIEW ON-SITE CONDITIONS AFTER EXCAVATION PRIOR TO PLACEMENT OF THE GRANULAR MATERIAL.
 - REFER TO ARCHITECTS AND LANDSCAPE ARCHITECTS DRAWINGS FOR BUILDING AND HARDSURFACE AREAS AND DIMENSIONS.
 - REFER TO THE STORMWATER MANAGEMENT REPORT (R-2023-143) PREPARED BY NOVATECH.
 - SAW CUT AND KEY GRIND ASPHALT AT ALL ROAD CUTS AND ASPHALT TIE IN POINTS AS PER CITY OF OTTAWA STANDARDS (R10).

- BENCHMARK NOTES:**
- ELEVATIONS SHOWN ARE GEODETIC AND ARE REFERRED TO THE CGVD25 GEODETIC DATUM.
 - IT IS THE RESPONSIBILITY OF THE USER OF THIS INFORMATION TO VERIFY THAT THE JOB BENCHMARK HAS NOT BEEN ALTERED OR DISTURBED AND THAT ITS RELATIVE ELEVATION AND DESCRIPTION AGREES WITH THE INFORMATION SHOWN ON THIS DRAWING.
 - BENCHMARK WAS PROVIDED ON SURVEYOR'S REAL PROPERTY REPORT PART 1, PLAN OF PART OF LOT 5, CONCESSION 2 (OTTAWA FRONT) GEOGRAPHIC TOWNSHIP OF GLOUCESTER, CITY OF OTTAWA, SURVEYED BY ANNIS, OSULLIVAN AND VOLLEBECK LTD.

INLET CONTROL DEVICE DATA TABLE: AREA A-1 (INCL. AREAS OS-1 & OS-2)

DESIGN EVENT	KCD TYPE (PLUG TYPE)	ORIFICE STRUCTURE	SWAMPERS OF ORIFICE (PER UNIT)	PEAK DESIGN FLOW (L/S)	DESIGN HEAD (M)	DESIGN ELEVATION (M)	WATER STORAGE (M ³)	AVAILABLE STORAGE (M ³)
12 HR	18mm RA	STM#4 112	375mm PVC	82	2.68	81.17	152.4	1088.0m ³
12 HR	APPROX. 80% L/S	1200mm	PVC	562	2.68	81.17	206.3	1088.0m ³
1500 YR	TYPE KCD			1028	2.68	81.32	821.7	

INLET CONTROL DEVICE DATA TABLE: AREA A2 (POND)

DESIGN EVENT	KCD TYPE (PLUG TYPE)	ORIFICE STRUCTURE	SWAMPERS OF ORIFICE (PER UNIT)	PEAK DESIGN FLOW (L/S)	DESIGN HEAD (M)	DESIGN ELEVATION (M)	WATER STORAGE (M ³)	AVAILABLE STORAGE (M ³)
12 HR	18mm RA	STM#4 116	375mm PVC	264	0.86	79.26	37.1	485.5m ³
12 HR	APPROX. 80% L/S	1000mm	PVC	333	0.86	79.26	124.1	485.5m ³
1500 YR	TYPE KCD			322	1.20	79.51	285.4	

NOTE:
THE POSITION OF ALL POLE LINES, CONDUITS, WATERMANS, SEWERS AND OTHER UNDERGROUND AND OVERGROUND UTILITIES AND STRUCTURES IS NOT NECESSARILY SHOWN ON THE CONTRACT DRAWINGS, AND WHERE SHOWN, THE ACCURACY OF THE POSITION OF SUCH UTILITIES AND STRUCTURES IS NOT GUARANTEED. BEFORE STARTING WORK, DETERMINE THE EXACT LOCATION OF ALL SUCH UTILITIES AND STRUCTURES AND ASSUME ALL LIABILITY FOR DAMAGE TO THEM.

OWNER INFORMATION
NOKIA CO COLLIERS
181 BAY STREET, SUITE 1400
TORONTO, ONTARIO, M5J 2V1
ERIK CUNNINGTON
PHONE: (416) 920-0155
EMAIL: erik.cunnington@colliers.com

SURVEYOR
ANNIS, OSULLIVAN, VOLLEBECK LTD.
14 CONCOURSE GATE, SUITE 400
OTTAWA, ONTARIO, K2E 7S6
PHONE: (613) 727-0850

CIVIL ENGINEER/LANDSCAPE ARCHITECT
NOVATECH ENGINEERS, PLANNERS & LANDSCAPE ARCHITECTS
240 MICHAEL COWPLAND DRIVE, SUITE 200
OTTAWA, ONTARIO, K2M 1P6
PHONE: (613) 254-9643

No.	REVISION	DATE	BY
3.	REVISED AS PER CITY COMMENTS	FEB 14/24	FST
2.	ISSUED FOR SPC APPROVAL	NOV 7/23	FST
1.	PRELIMINARY PLANS ISSUED TO CITY	OCT 2/23	FST

SCALE	CHECKED	DATE	BY
1:400	CV		
	FST		
	CV		
	FST		
	FST		

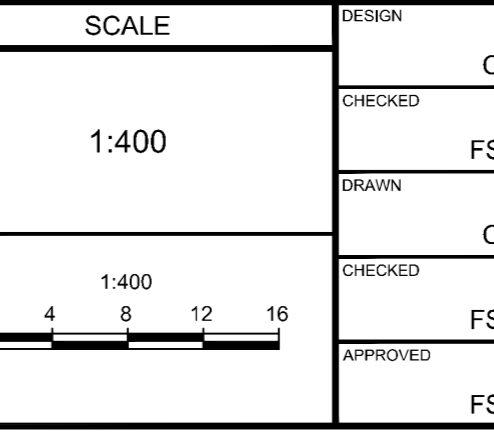

FOR REVIEW ONLY

PROFESSIONAL ENGINEER
F.S. TRAVETTES
1020412590
February 14, 2024
PROVINCE OF ONTARIO

NOVATECH
Engineers, Planners & Landscape Architects
Suite 200, 340 Michael Cowpland Drive
Ottawa, Ontario, Canada K2M 1P6
Telephone: (613) 254-9643
Facsimile: (613) 254-9887
Website: www.novatech-eng.com

LOCATION
CITY OF OTTAWA
600 MARCH ROAD - NOKIA PARKING LOT EXPANSION

DRAWING NAME
POST-DEVELOPMENT
STORMWATER MANAGEMENT
PLAN

PROJECT NO.: 121334
REV: 121334-SWM
DRAWING NO.: 121334-SWM
PLAN #1907

07-12-23-0138