

652 Flagstaff Drive

Transportation Impact Assessment

Step 1 Screening Report

Step 2 Scoping Report

Step 3 Forecasting Report

Step 4 Strategy Report

Prepared for:

The Nukk
237 Madhu Cres
Ottawa, ON K2C 4J2

Prepared by:



6 Plaza Court
Ottawa, ON K2H 7W1

January 2024

PN: 2022-136

Table of Contents

1	Screening	1
2	Existing and Planned Conditions	1
2.1	Proposed Development.....	1
2.2	Existing Conditions	3
2.2.1	Area Road Network	3
2.2.2	Existing Intersections.....	3
2.2.3	Existing Driveways	3
2.2.4	Cycling and Pedestrian Facilities.....	4
2.2.5	Existing Transit.....	5
2.2.6	Existing Area Traffic Management Measures.....	6
2.2.7	Existing Peak Hour Travel Demand.....	6
2.2.8	Collision Analysis	8
2.3	Planned Conditions.....	10
2.3.1	Changes to the Area Transportation Network	10
2.3.2	Other Study Area Developments.....	11
3	Study Area and Time Periods	13
3.1	Study Area	13
3.2	Time Periods	13
3.3	Horizon Years.....	13
4	Exemption Review	13
4.1	TIA Exemptions	13
4.2	Comparison to Previous TIA	14
4.3	Scoped Exemptions	14
5	Development Design	14
5.1	Design for Sustainable Modes	14
5.2	Circulation and Access.....	15
6	Parking.....	15
6.1	Parking Supply	15
7	Access Intersections Design	15
7.1	Location and Design of Access.....	15
8	Transportation Demand Management	15
8.1	Context for TDM	15
8.2	Need and Opportunity.....	15
8.3	TDM Program	15
9	Summary of Improvements Indicated and Modifications Options.....	16
10	Conclusion	17

List of Figures

Figure 1:	Area Context Plan	1
Figure 2:	Concept Plan.....	2
Figure 3:	Study Area Pedestrian Facilities	4

Figure 4: Study Area Cycling Facilities 5
 Figure 5: Existing Study Area Transit Service..... 6
 Figure 6: Existing Study Area Transit Stops 6
 Figure 7: Existing Traffic Counts 7
 Figure 8: Study Area Collision Records 9

Table of Tables

Table 1: Existing Intersection Operations..... 8
 Table 2: Study Area Collision Summary, 2016-2020 8
 Table 3: Summary of Collision Locations, 2016-2020 9
 Table 4: Borrisokane Road between Strandherd Drive and Cambrian Road Collision Summary 9
 Table 5: Cambrian Road at Borrisokane Road Collision Summary 10
 Table 6: Exemption Review 13
 Table 7: Difference in Primary and Pass-by Vehicle Trips by Peak Hour..... 14
 Table 8: Additional TIA Exemptions..... 14

List of Appendices

- Appendix A – TIA Screening Form and Certification Form
- Appendix B – Turning Movement Count Data
- Appendix C – Synchro Intersection Worksheets – Existing Conditions
- Appendix D – Collision Data
- Appendix E – Cambrian Road at Apolune Street/Elevation Road Functional Design
- Appendix F – Borrisokane Road at Flagstaff Drive Functional Design
- Appendix G – Trip Generation Comparison
- Appendix H – TDM Checklist
- Appendix I – Turning Templates

1 Screening

This study has been prepared according to the City of Ottawa's 2017 Transportation Impact Assessment (TIA) Guidelines. Accordingly, a Step 1 Screening Form has been prepared and is included as Appendix A, along with the Certification Form for the TIA Study PM. As shown in the Screening Form, a TIA is required including the Design Review component and the Network Impact component. This report is in support of a site plan application.

2 Existing and Planned Conditions

2.1 Proposed Development

The existing greenfield site, located at 3387 Borrisokane Road, is zoned as Local Commercial (LC7[1694]). The proposed development includes two commercial buildings comprising a total of 14,631 sq. ft. of floor area. A full-movement access is proposed for the development on Flagstaff Drive, accessing 68 parking spaces within a surface lot and six bike parking spaces. Development is anticipated to occur in a single phase and to be built out by 2025. Figure 1 illustrates the study area context. Figure 2 illustrates the proposed concept plan.

Figure 1: Area Context Plan

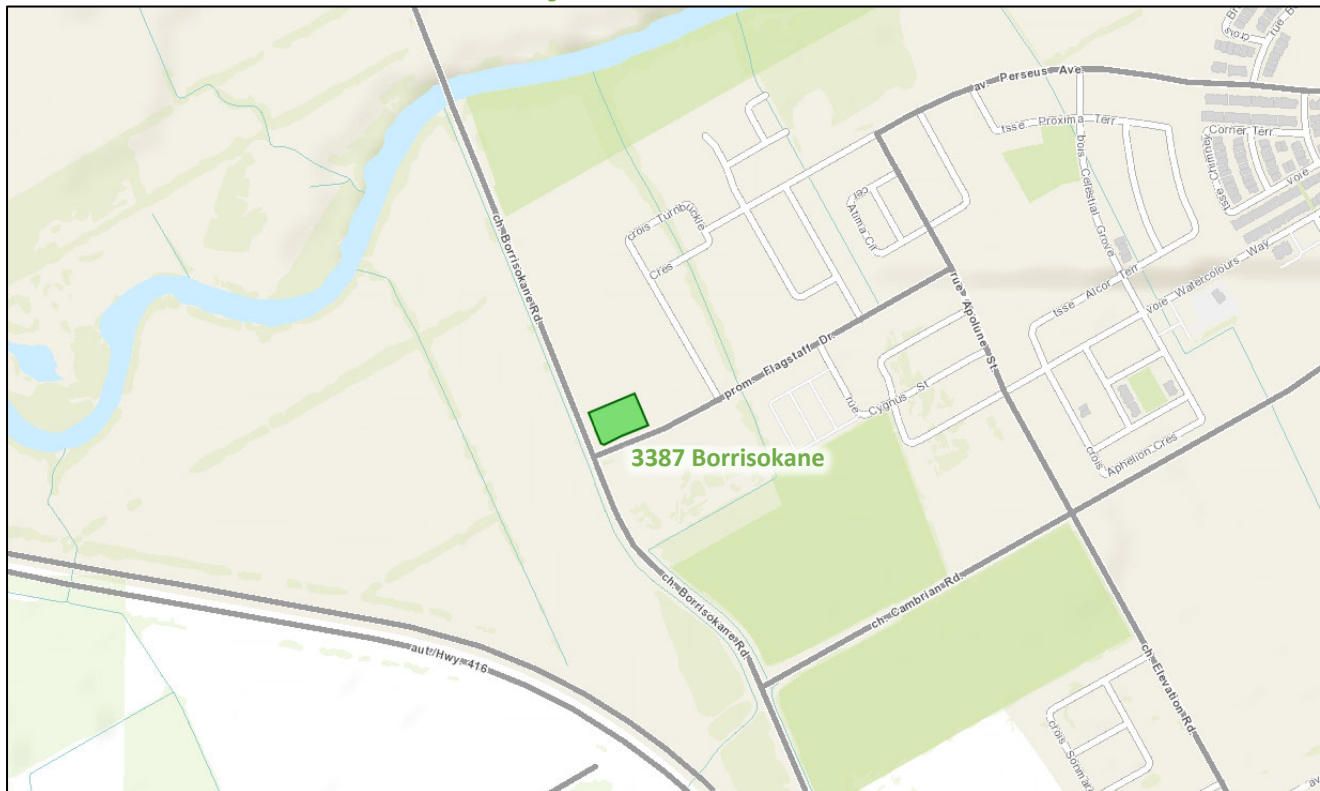

Source: <http://maps.ottawa.ca/geoOttawa/> Accessed: March 27, 2023

DRAWING LEGEND

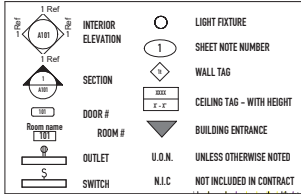

SITE PLAN LEGEND

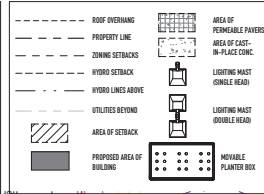

ZONING STATISTICS

ZONE: LCT (L4A)	TYPE LOCAL COMMERCIAL ZONE	REQUIRED	PROVIDED
MIN. LOT WIDTH:	NO MIN.		
MIN. LOT AREA:	NO MIN.	47,248 m ² / 4.72 BA	
MIN. FRONT YARD SETBACK:	3 m	3 m	
MIN. CORNER SIDE YARD SETBACK:	3 m	3 m	
MIN. INTERIOR SIDE YARD SETBACK:	5 m	5 m	
MIN. REAR YARD SETBACK:	NO MINIMUM		
MIN. LANDSCAPE AREA (FRONT YARD):	3 m buffer	3 m buffer	
MAX. BUILDING HEIGHT:	12.5 m	6.97 m	
MAX. FLOOR SPACE INDEX:	NO MAX.	31%	

PARKING STATISTICS

ZONE: LCT (L4A)	TYPE LOCAL COMMERCIAL ZONE	REQUIRED	PROVIDED
FULL-SIZED PARKING SPACES (5.2m D x 2.4m W)	3.4 per 100 m ² of gross leasable floor area - 47	34	
COMPACT-SIZED PARKING SPACES (4.6m D x 2.4m W)	Max. 50% of Regular sized parking spaces - 15	34	
4x per section 100 (3) - Parking Space provision		TOTAL SPACES: (48)	
BARREER-FREE PARKING SPACES	1 Space for 20-99 vehicle parking spaces	1	
BIKE PARKING SPOTS	1 per 250 m ² of gross floor area - 6	6	
MIN. DRIVE AISLE WIDTH	6.7 m	6.7 m	

PARKING SPACE LEGEND

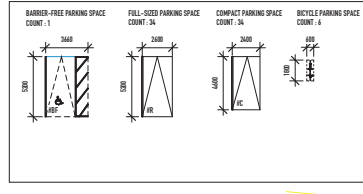

CONTEXT PLAN



NOTE:
 1. SITE PLAN BASED ON TOPOGRAPHIC SURVEY PROVIDED BY:
 J.B. Barnes Limited
 Suite 100, 45 Ottawa Drive
 Ottawa, ON K2N 2A9
 Tel: 613-721-7244
 DATE: March 28, 2023
 2. ALL SHOW IS TO BE REMOVED FROM SITE.
 3. ALL PLANTING/LANDSCAPING IN THIS PLAN IS FOR GRAPHICAL PURPOSES ONLY. FOR EXACT SPECIFICATIONS OF PLANT SPECIES, REFER TO LANDSCAPE DRAWINGS.

Ontario Association of Architects
 7008
 Note: Should there be any conflict between drawings, Contractor is to confirm intent with Owner prior to the execution of work.

DESIGN & SYSTEMS
 TTF ENGINEERING
 FOTENN Planning + Design
 Palmer PART OF SLR
 GRADIENTWIND ENGINEERS & SCIENTISTS
 Ruhland & Associates Ltd
 LRL ENGINEERING
 NUKK
 25+6 ARCHITECTURE URBAN DESIGN

No.	Description	Date
1	ISSUED FOR PRE-DESIGN MEETING	2022.10.19
2	ISSUED FOR CLIENT COORDINATION	2022.11.22
3	ISSUED FOR 75% SK PRESENTATION	2023.02.10
4	ISSUED FOR COORDINATION	2023.02.22
5	ISSUED FOR CIVIL COORDINATION	2023.04.05
6	ISSUED FOR PLANNER COORDINATION	2023.04.24
7	ISSUED FOR TRANSPORTATION COORDINATION	2023.05.02
8	RE-ISSUED FOR COORDINATION	2023.05.26
9	ISSUED FOR SITE PLAN CONTROL	2023.06.09
10	ISSUED FOR SOC 80	2023.06.21
11	ISSUED FOR COORDINATION	2023.07.14
12	ISSUED FOR COORDINATION	2023.11.23

THE NUKK
 652 FLAGSTAFF DRIVE
 OTTAWA, ON

SITE PLAN

Project number: 22021
 Date: 2023.12.08
 Drawn by: GLM
 Checked by: JSL

SP01
 Scale: As indicated

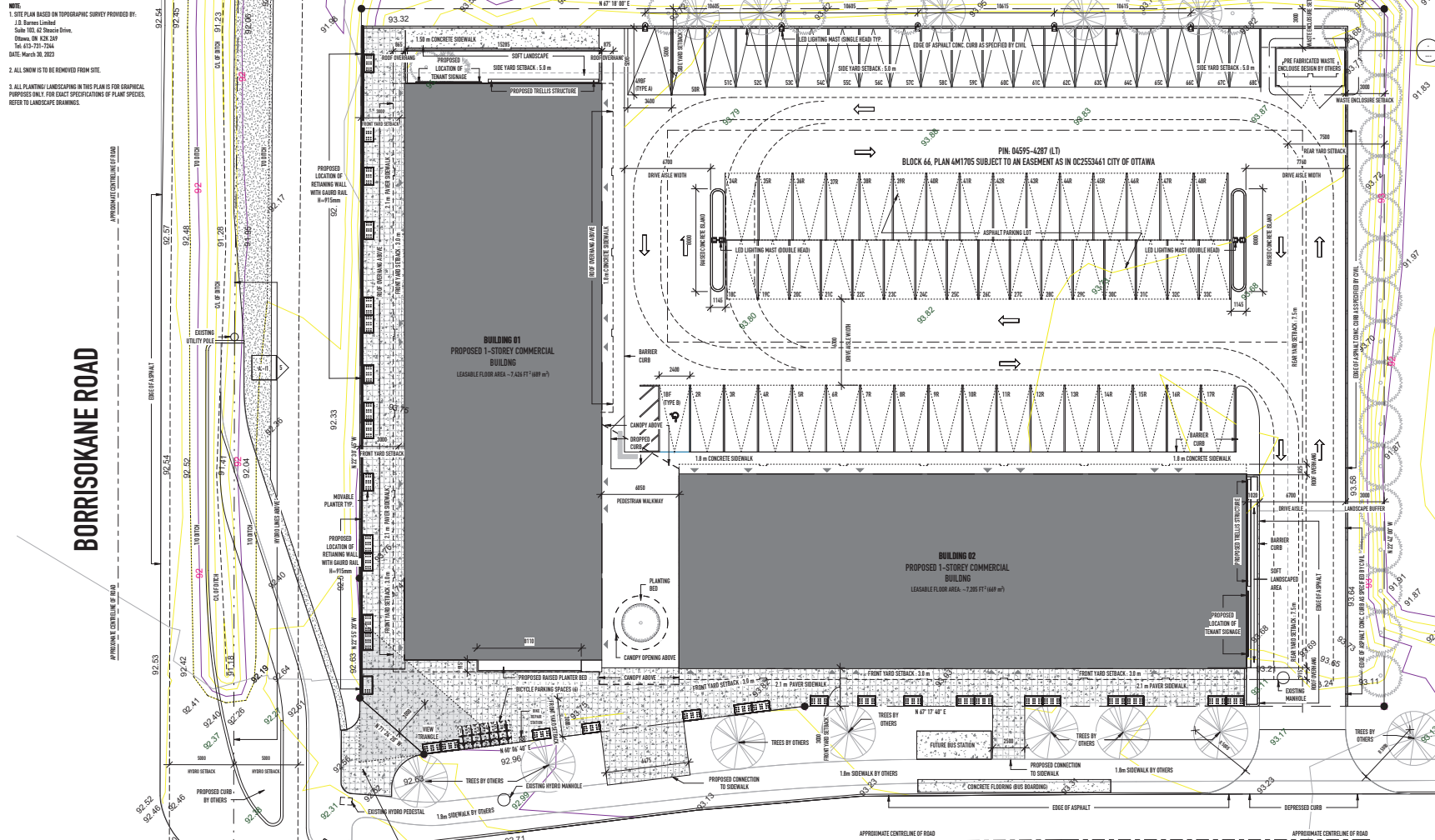

1 SITE PLAN
 1: 150

2.2 Existing Conditions

2.2.1 Area Road Network

Borrisokane Road: Borrisokane Road is a City of Ottawa arterial road, north of Cambrian Road, with a two-lane rural cross-section including gravel shoulders and an 80 km/h posted speed limit. South of Cambrian Road, Borrisokane Road is a collector road. The Ottawa Official Plan reserves a 37.5-metre right of way north of Cambrian Road, and Borrisokane Road is within the MTO Highway 416 right-of-way south of Cambrian Road.

Cambrian Road: Cambrian Road is a City of Ottawa arterial road with a two-lane rural cross-section and a posted speed limit of 50 km/h. A sidewalk is provided on the north side of the road eastward of approximately 175 metres west of Apolune Street. Sidewalks are provided east of Seeley's Bay Street where Cambrian Road has an urban cross-section. The Ottawa Official Plan reserves a 37.5 metre right-of-way between Borrisokane Road and Jockvale Road.

Flagstaff Drive: Flagstaff drive is a City of Ottawa collector road with a two-lane urban cross-section including sidewalks on both sides of the road and with on-street parking permitted on the south side of the road. The unposted speed limit is assumed to be 50 km/h and the measured right-of-way is 24.0 metres.

Apolune Street: Apolune Street is a City of Ottawa collector road with a two-lane urban cross-section including on-street parking permitted and sidewalks on both sides of the road. The unposted speed limit is assumed to be 50 km/h and the measured right-of-way is 24.0 metres.

2.2.2 Existing Intersections

The existing key area intersections within one kilometre of the site have been summarized below:

Borrisokane Road & Cambrian Road

The intersection of Borrisokane Road and Cambrian Road is a T-intersection with stop-control on Cambrian Road. The northbound approach consists of a shared through/right-turn lane and the southbound approach consists of a shared left-turn/through lane. The westbound approach consists of a shared left-turn/right-turn lane. No turn restrictions are noted.

Apolune Street and Cambrian Road

The intersection of Apolune Street and Cambrian Road is a T-intersection with stop-control on Apolune Street. The southbound approach consists of a shared left-turn/right-turn lane. The eastbound approach consists of a shared left-turn/through lane and the westbound approach consists of a shared through/right-turn lane. No turn restrictions are noted.

Borrisokane Road & Flagstaff Drive

The intersection of Borrisokane Road at Flagstaff Drive is a T-intersection with stop-control on Flagstaff Drive. The northbound approach consists of a shared left-turn/through lane and the southbound approach consists of a shared through/right-turn lane. The westbound approach consists of a shared left-turn/right-turn lane. No turn restrictions are noted.

2.2.3 Existing Driveways

Driveways within 200 metres of proposed site access, four double driveways to eight townhomes are present on the north side of Flagstaff Drive. These driveways will not be significant traffic generators and do not impact site driveway operations.

2.2.4 Cycling and Pedestrian Facilities

Figure 3 illustrates the pedestrian facilities in the study area and Figure 4 illustrates the cycling facilities.

No pedestrian or cycling facilities are provided along Borrisokane Road and a sidewalk is present on the north side of Cambrian Road up to the woodlot. Sidewalks are provided along both sides of Apolune Street, on both sides of Flagstaff Drive east of Cygnus Street, and on the south side of Flagstaff Drive to the west. As the adjacent community phases develop, the sidewalk along Flagstaff Drive is anticipated to be extended westward.

The Re-Aligned Greenbank Road will be a spine cycling route, and Cambrian Road, Borrisokane Road, and Apolune Street are designated as local cycling routes. South of Cambrian Road, Apolune Street will continue as Elevation Road, is a local route, and is anticipated to include cycletracks. Pathways are designated along both sides of the Jock River throughout the study area.

Figure 3: Study Area Pedestrian Facilities

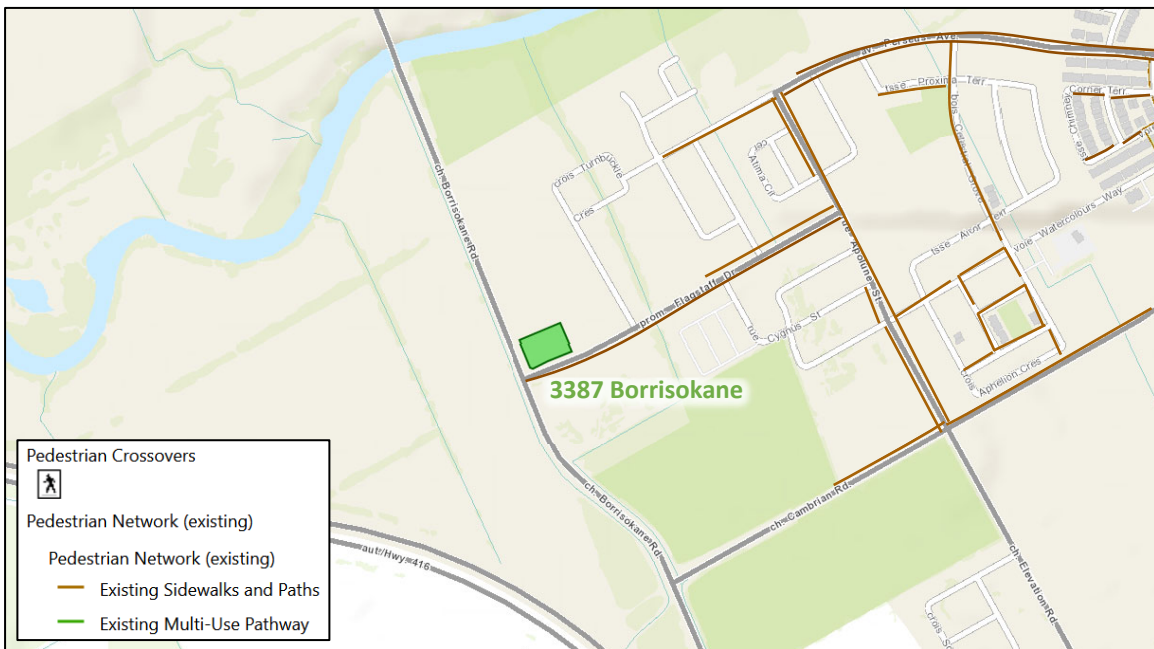

Source: <http://maps.ottawa.ca/geoOttawa/> Accessed: November 9, 2023

Figure 4: Study Area Cycling Facilities



Source: <http://maps.ottawa.ca/geoOttawa/> Accessed: March 27, 2023

2.2.5 Existing Transit

There is no existing transit service along the boundary roads, however it is understood that through the development of Barrhaven South, transit service will frequently expand and change and thus service at the time of build-out will be different than existing. East of the subject development, Route #75 runs along Cambrian Road. The frequency of this route as of March 27, 2023 is:

- Route #75 – 15-20-minute service midday, 30-minute service mornings and evenings

Figure 5 illustrates the transit system map in the study area and Figure 6 illustrates nearby transit stops.

Figure 5: Existing Study Area Transit Service

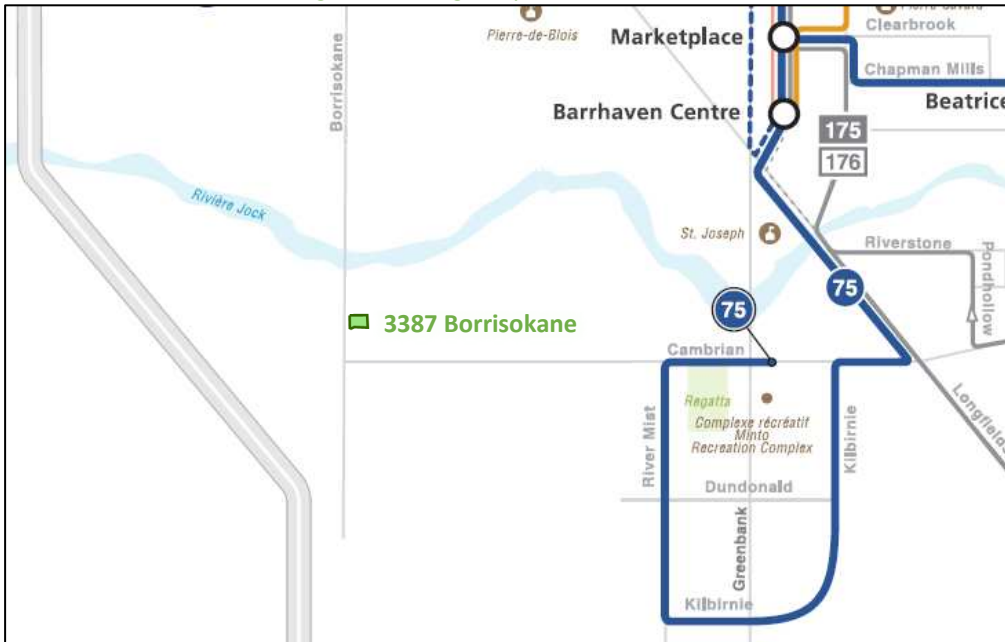

Source: <http://www.octranspo.com/> Accessed: March 27, 2023

Figure 6: Existing Study Area Transit Stops

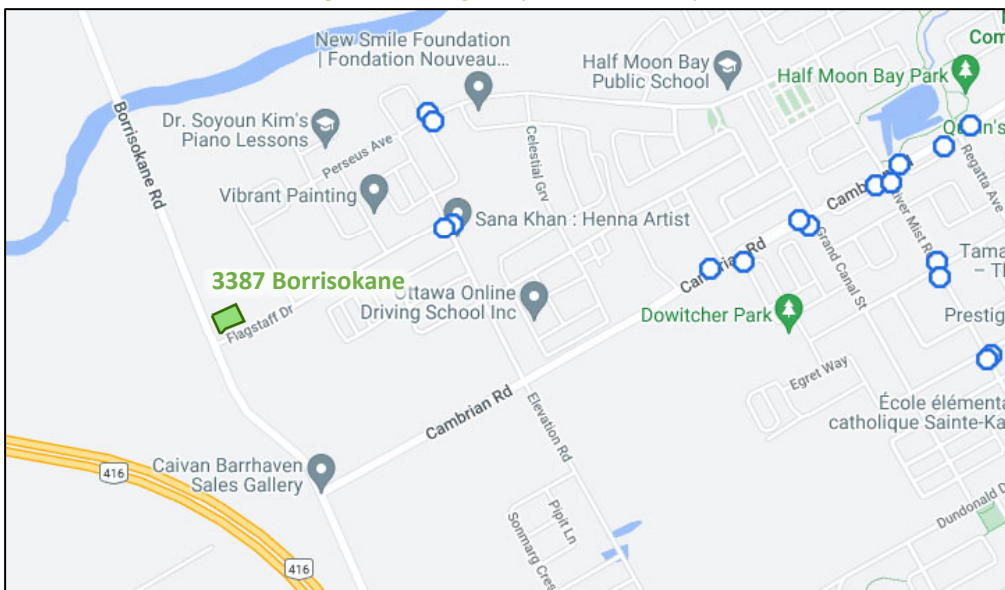

Source: <http://www.octranspo.com/> Accessed: March 27, 2023

2.2.6 Existing Area Traffic Management Measures

Bulb-outs at local road intersections and on-street parking are the primary traffic management measures within the study area.

2.2.7 Existing Peak Hour Travel Demand

Existing turning movement counts for the intersection of Cambrian Road at Borrissokane Road were referenced from the TIA for Phase 3 of the subject Half Moon Bay West community (CGH, 2021) which used the existing horizon year of 2019. The turning movement volumes for the intersection of Cambrian Road and Apolune Street

were taken from the 3850 Cambrian Road TIA, which also used a 2019 horizon, and were used to balance the volumes at the intersection of Cambrian Road at Borrisokane Road.

Figure 7 illustrates the 2019 existing traffic counts and Table 1 summarizes the existing intersection operations. The level of service is based on average delay for unsignalized intersections. Detailed turning movement count data is included in Appendix B and the Synchro worksheets are provided in Appendix C.

Figure 7: Existing Traffic Counts

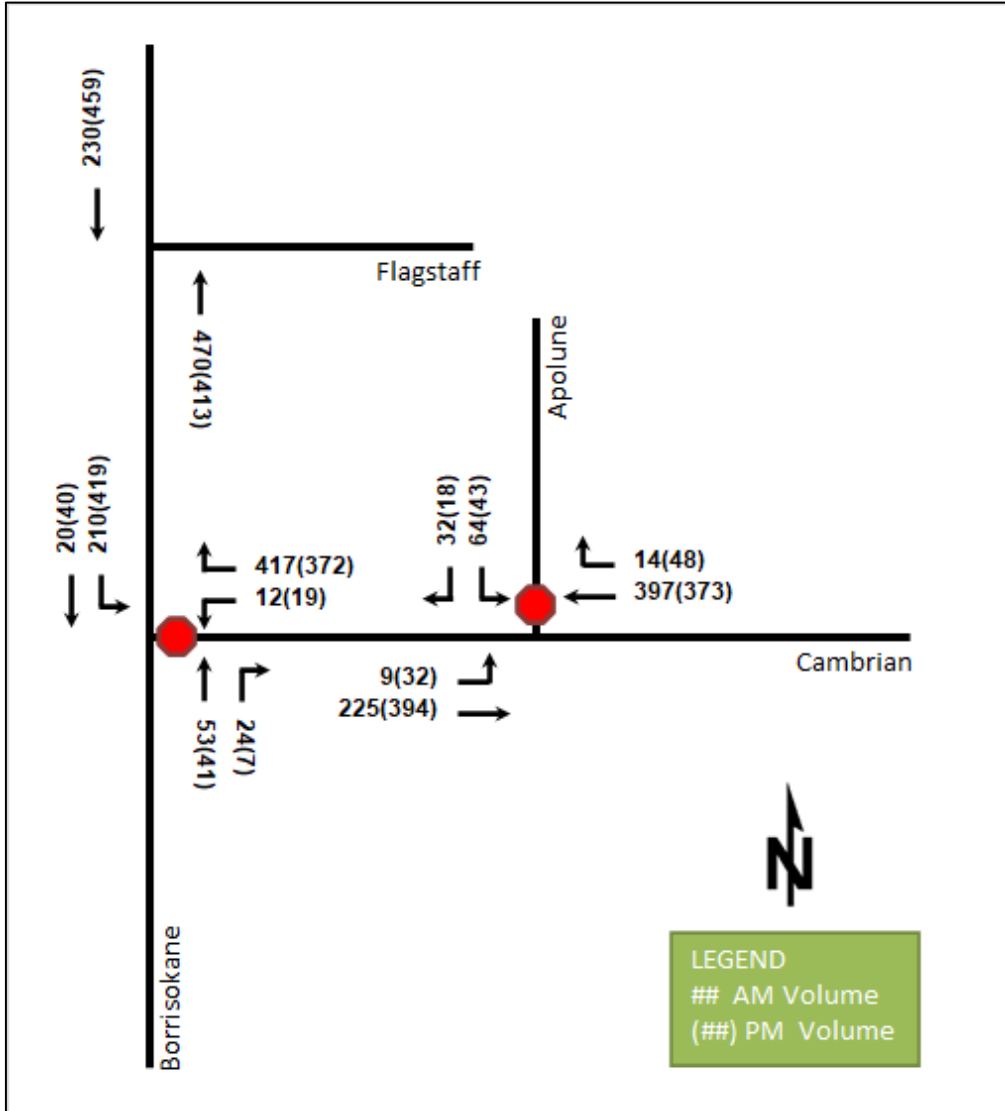

Table 1: Existing Intersection Operations

Intersection	Lane	AM Peak Hour				PM Peak Hour			
		LOS	V/C	Delay (s)	Q (95 th)	LOS	V/C	Delay (s)	Q (95 th)
Cambrian Road & Borrisokane Road <i>Unsignalized</i>	WBL/R	B	0.50	12.5	21.8	B	0.52	14.0	23.3
	NBT/R	-	-	-	-	-	-	-	-
	SBL/T	A	0.16	7.8	3.8	A	0.30	8.3	9.8
	Overall	A	-	9.5	-	A	-	10.0	-
Cambrian Road & Apolune Street <i>Unsignalized</i>	EBL/T	A	0.01	8.3	0.0	A	0.03	8.4	0.8
	WBT/R	-	-	-	-	-	-	-	-
	SBL/R	C	0.24	15.7	6.8	C	0.21	18.7	6.0
	Overall	A	-	2.1	-	A	-	1.5	-

Notes: Saturation flow rate of 1800 veh/h/lane
Queue is measured in metres
Peak Hour Factor = 0.90

m = metered queue
= volume for the 95th %ile cycle exceeds capacity

The study area intersection for the existing conditions is expected to operate well during both peak hours. No capacity issues are noted.

2.2.8 Collision Analysis

Collision data have been acquired from the City of Ottawa open data website (data.ottawa.ca) for five years prior to the commencement of this TIA for the surrounding study area road network. Table 2 summarizes the collisions types and conditions in the study area, Figure 8 illustrates the intersections and segments analyzed, and Table 3 summarizes the total collisions for each of these locations. Collision data are included in Appendix D.

Table 2: Study Area Collision Summary, 2016-2020

		Number	%
Total Collisions		38	100%
Classification	Fatality	0	0%
	Non-Fatal Injury	11	29%
	Property Damage Only	27	71%
Initial Impact Type	Angle	2	5%
	Rear end	9	24%
	Turning Movement	2	5%
	SMV Other	24	63%
	Other	1	3%
Road Surface Condition	Dry	22	58%
	Wet	7	18%
	Loose Snow	4	11%
	Ice	4	11%
	Loose Gravel	1	3%
Pedestrian Involved		0	0%
Cyclists Involved		0	0%

Figure 8: Study Area Collision Records

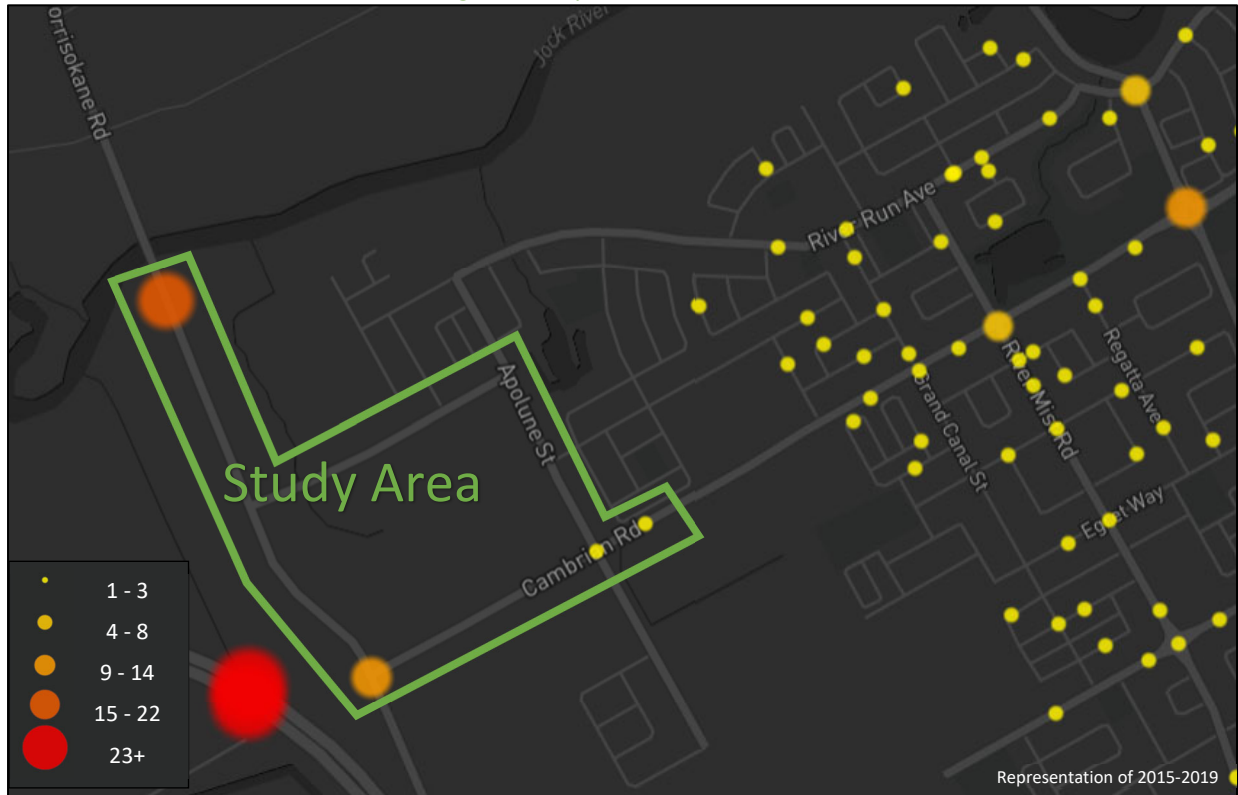

Table 3: Summary of Collision Locations, 2016-2020

Intersections / Segments	Number	%
Intersections / Segments	38	100%
Borrisokane Rd btwn Cambrian Rd & Strandherd Dr	23	61%
Cambrian Rd @ Borrisokane Rd	12	32%
Cambrian Rd btwn Borrisokane Rd & Grand Canal St	1	3%
Apolune St @ Cambrian Rd	1	3%
Apolune St btwn Cambrian Rd & End	1	3%

Within the study area, the segment of Borrisokane Road between Cambrian Road and Strandherd Drive, and the intersection of Cambrian Road at Borrisokane Road are noted to have experienced higher collisions than other locations. Table 5 and Table 5 summarizes the collision types and conditions for these locations.

Table 4: Borrisokane Road between Strandherd Drive and Cambrian Road Collision Summary

Total Collisions		Number	%
Total Collisions		23	100%
Classification	Fatality	0	0%
	Non-Fatal Injury	5	22%
	Property Damage Only	18	78%
Initial Impact Type	Rear end	3	13%
	SMV Other	19	83%
	Other	1	4%
Road Surface Condition	Dry	15	65%
	Wet	2	9%
	Loose Snow	3	13%
	Ice	3	13%

	Number	%
Total Collisions	23	100%
Pedestrian Involved	0	0%
Cyclists Involved	0	0%

The segment of Borrisokane Road between Strandherd Drive and Cambrian Road had a total of 23 collisions during the 2016-2020 time period with 18 involving property damage only and the remaining five having non-fatal injuries. Nineteen of these collisions were classified as SMV (other) and the remaining four were split between rear end and other. The higher SMV other collisions are typical of rural roadways, including weather related accidents (37% during non-dry conditions), animal strikes and speeding. Alternative paving materials may be explored by the City for this segment of road. Once the area builds out north of the Jock River, and north of Flagstaff Drive, collisions may also reduce with slower travel speeds and improved lighting/visibility.

Table 5: Cambrian Road at Borrisokane Road Collision Summary

		Number	%
Total Collisions		12	100%
Classification	Fatality	0	0%
	Non-Fatal Injury	5	42%
	Property Damage Only	7	58%
Initial Impact Type	Angle	1	8%
	Rear end	6	50%
	Turning Movement	1	8%
	SMV Other	4	33%
Road Surface Condition	Dry	5	42%
	Wet	5	42%
	Loose Sand or Gravel	1	8%
	Ice	1	8%
Pedestrian Involved		0	0%
Cyclists Involved		0	0%

The Cambrian Road at Borrisokane Road intersection had a total of 12 collisions during the 2016-2020 time period, with seven involving property damage only and the remaining five having non-fatal injuries. The collision types are most represented by rear end with six collisions, followed by SMV (other) with four, and angle and turning movement each with one. Rear end collisions are typical of areas with queueing vehicles, where half of this type of collision occurred in the most recent analysis year of 2020 where queueing is expected to have increased with area buildout. Rear end collisions occurred with equal frequency on the southbound and westbound approaches. Conversely, no SMV (other) collisions were registered after 2018, which may be influenced by the change in nature of the intersection from a low-volume rural context to a higher-volume suburban context. Weather conditions may affect collisions at this location. It is noted that the City is undertaking the design to signalize this intersection and improved collision rates are likely to occur from the additional control.

2.3 Planned Conditions

2.3.1 Changes to the Area Transportation Network

The Re-Aligned Greenbank Road will be located east of the proposed development. While listed within the Transportation Master plan Affordable Network, Re-Aligned Greenbank Road is not anticipated be completed to Cambrian Road by 2031. Beyond the construction of this segment, Re-Aligned Greenbank Road will extend south of Cambrian Road to Barnsdale Road. The proposed cross-section of Re-Aligned Greenbank Road is a divided four-lane cross-section including sidewalks, cycletracks, and median bus lanes.

A new interchange at Barnsdale Road to Highway 416 is currently in the preliminary design phase of the Environmental Assessment (EA) study to support the existing and future growth within Barrhaven, specifically south of the Jock River and adjacent to the Fallowfield Drive interchange. The interchange is anticipated to be completed post 2031.

Intersection Control Measures outlined in the 2019 Ottawa Development Charges By-Law are expected to be implemented at the following intersections:

- Cambrian Road at Borrisokane Road – intersection modifications planned to begin within 2-3 years per the City’s Planned Construction Projects portal
- Cambrian Road at Apolune Street/Elevation Road – signalization understood to be funded for 2024 construction, the functional design by Stantec (2019) is provided in Appendix E
- Borrisokane Road at Flagstaff Drive – intersection modifications planned to begin this year per the City’s Planned Construction Projects portal, the functional design exercise by CGH is ongoing and the current plan is provided in Appendix F

2.3.2 Other Study Area Developments

Mattamy’s Half Moon Bay West Phase 3 (3345 Borrisokane Road, 1108 Apolune Street, & 3900 Cambrian Road)

The proposed subdivision is situated within the Mattamy Development of Half Moon Bay West, this phase of which is anticipated to be built-out during 2025. The development will include 38 detached single-family homes, 190 townhomes, and a 0.43-hectare commercial block. (CGH Transportation, 2021)

3555 Borrisokane Road

The proposed development includes a site plan application consisting of a car wash. It is anticipated to be built by 2023. This development forms a portion of the commercial block assessed within the Half Moon Bay West Phase 3 area. (D. J. Halpenny & Associates Ltd, 2022)

Glenview Homes (3387 Borrisokane Road)

The proposed development includes a plan of subdivision application consisting of 179 single family homes and 109 townhomes. It is anticipated to be built by 2023. (Stantec 2017)

OCSB Elementary School (135 Halyard Lane)

The proposed development application includes a site plan to have a single storey elementary school with approximately 800 students and a 2,970 sq. ft of childcare centre. It is anticipated to be built by 2023. (Dillon Consulting, 2022)

Mattamy’s Half Moon Bay West Phase 4 (3345 Borrisokane Road)

The proposed site is situated within the Mattamy Development of Half Moon Bay West, this phase of which is anticipated to be built-out during 2026. This phase of the development will include 59 detached single-family homes.

Minto’s Kennedy (3432 Greenbank Road)

The proposed development includes a plan of subdivision application consisting of 523 units, including 103 single family homes, 274 executive townhomes, and 146 avenue townhomes, and is anticipated to be built by 2024. (CGH Transportation, 2022)

Loblaws Companies Ltd. (3845 Cambrian Road)

The proposed development includes a site plan application consisting of an approximately 39,696 sq. ft retail development across two separate pads. It is anticipated to be built by 2025. The file has been initiated and no TIA is available at this time.

Choice Properties (3850 Cambrian Road)

The proposed development includes a site plan application consisting of a 16,960 sq.ft. of pharmacy and 20,960 sq.ft. of retail buildings totaling 37,920 sq. ft. It is anticipated to be built by 2024. The file has been initiated and no TIA is available at this time.

Metro Ontario Inc. (3831 Cambrian Road)

The proposed development includes a site plan application consisting of a 4,024 square metre supermarket, an attached 929 square metre retail store, an 830 square metre retail building, and a 1,060 square metre mixed-use building. It is anticipated to be built by 2023. (CGH Transportation, 2021)

Meadow's Phase 7-8 (3640 Greenbank Road)

The proposed development, which was named Phase 5 in the TIA, includes a plan of subdivision application. The concept plan considers a total of 221 townhouses and 125 single family units. The full build-out and occupancy of Phase 7 is now assumed to be 2023 and Phase 8 by 2025. (IBI, 2018)

Mattamy's Half Moon Bay South Phase 5 (3718 Greenbank Road)

The proposed development application includes a plan of subdivision application consisting of 67 single detached home units and 97 townhouse units. This development is under construction and is assumed to be completed by the end of 2022. (CGH Transportation, 2019)

Mattamy's Half Moon Bay South Phase 7/8 (3718 Greenbank Road)

The proposed development, located on the west of the Re-Aligned Greenbank Road corridor and includes a mixture of 228 stacked townhouse units, and is anticipated to be built by 2024. (CGH Transportation, 2022)

Caivan's Ridge Phases 1-2 (3809 Borrisokane Road)

This development will include 279 townhouse units and 311 detached home units. This development is expected to be built-out during 2025. (CGH Transportation, 2019)

Caivan's The Ridge Phase 3-4 (3713 Borrisokane Road)

This development will include 589 townhouse units and 61 detached housing units. This development is expected to be built-out during 2024. (CGH Transportation, 2021)

Caivan's Conservancy East Stage (3285, 3288, 3305 Borrisokane Road)

This development will include 600 single family homes and 600 townhouses and 100 mid-rise dwelling units. This development is expected to be built-out during 2029. (CGH Transportation, 2021).

Minto's Quinn's Pointe Stages 4 (3882 Barnsdale Road and 3960 Greenbank Road)

The proposed development application includes a plan of subdivision application consisting of 536 single-family dwelling units, 493 townhomes, 100 apartment units, and two elementary schools. Phases 2 and 3 have been completed, and Phase 4 is expected to be completed by 2025. (Stantec, 2018)

AIBC Manufacturing Site (3713 Borrisokane Road)

The site includes approximately 3,250 square metres of general office space and 9,385 square metres of industrial buildings. This development began operations in 2022, and the office component will be completed by 2023. (CGH Transportation, 2020)

3 Study Area and Time Periods

3.1 Study Area

The study area will include the intersections of:

- Borrisokane Road at Flagstaff Drive
- Borrisokane Road at Cambrian Road
- Apolune Street at Cambrian Road

The boundary streets will be Borrisokane Road and Flagstaff Drive. The Jock River screenline (SL49), which runs along the Jock River, intersects Borrisokane Road north of the proposed development and will not be reviewed within this report.

3.2 Time Periods

As the proposed development is local retail, situated within a residential context, the weekday AM and PM peak hours will be examined.

3.3 Horizon Years

The anticipated build-out year is 2026. As a result, the full build-out plus five years horizon year is 2031.

4 Exemption Review

4.1 TIA Exemptions

Table 6 summarizes the exemptions for this TIA.

Table 6: Exemption Review

Module	Element	Explanation	Exempt/Required
Design Review Component			
4.1 Development Design	4.1.2 Circulation and Access	Only required for site plans	Required
	4.1.3 New Street Networks	Only required for plans of subdivision	Exempt
4.2 Parking	4.2.1 Parking Supply	Only required for site plans	Required
	4.2.2 Spillover Parking	Only required for site plans where parking supply is 15% below unconstrained demand	Exempt
Network Impact Component			
4.5 Transportation Demand Management	All Elements	Not required for site plans expected to have fewer than 60 employees and/or students on location at any given time	Required
4.6 Neighbourhood Traffic Management	4.6.1 Adjacent Neighbourhoods	Only required when the development relies on local or collector streets for access and total volumes exceed ATM capacity thresholds	Exempt
4.8 Network Concept		Only required when proposed development generates more than 200 person-trips during the peak hour in excess of equivalent volume permitted by established zoning	Exempt

4.2 Comparison to Previous TIA

The Half Moon Bay phase 3 (3345, 3387 Borrisokane Road, 1108 Apolune Street, & 3900 Cambrian Road) TIA included the subject parcel as part of the plan of subdivision application. The land uses and floor areas used for trip generation for this parcel within that study was assumed based on the characteristics of a nearby local commercial parcel to the north employing rates from the ITE Trip Generation Manual 10th Edition (2017). A comparison of the primary and pass-by vehicle trip generation for the subject parcel as forecast between the plan of subdivision TIA and the updated concept are summarized in Table 7. The trip generation for each scenario is provided in Appendix G.

Table 7: Difference in Primary and Pass-by Vehicle Trips by Peak Hour

Travel Mode	AM Peak Hour			PM Peak Hour		
	In	Out	Total	In	Out	Total
Auto Driver	-12	3	-10	13	-6	6
Pass-by	9	6	15	19	19	38

As shown above, the site is forecast to generate ten fewer AM and six additional PM peak hour two-way primary auto trips than assumed within the TIA for the plan of subdivision. Additional pass-by trips of 15 AM and 38 PM peak hour two-way vehicles are forecast.

Per the site’s function of local commercial, the site’s trip distribution is assumed to be mostly between the site and the community to the east. Therefore, impacts on peak directional travel on the arterial road network is assumed to be negligible for the marginal increase in site traffic above that assumed in the plan of subdivision TIA.

4.3 Scoped Exemptions

The difference in auto trips between the assumptions employed within the plan of subdivision TIA and updated site concept is lower than the threshold for trip generation triggering a TIA. As the site’s traffic impacts have already been recently studied, and the impacts from the marginal increase in site generated volumes are anticipated to be negligible, it is recommended that additional exemptions also be applied to the subject TIA as summarized in Table 8.

Table 8: Additional TIA Exemptions

Module	Element
3.1 Development Generated Travel Demand	All Elements
3.2 Background Network Travel Demand	All Elements
3.3 Demand Rationalization	All Elements
4.3 Boundary Street Design	All Elements
4.4 Access Intersections	4.4.2 Intersection Control
	4.4.3 Intersection Design
4.7 Transit	All Elements
4.9 Network Intersections	All Elements

5 Development Design

5.1 Design for Sustainable Modes

The proposed development is a retail strip with surface parking for both automobiles and bicycles located on the surface surrounding buildings. A total of 68 vehicle parking spaces and six bicycle parking spaces will be provided for the site. Both the bicycle parking spaces and the bike repair station are proposed on the southwest side of the site, near the intersection of Borrisokane Road at Flagstaff Drive.

A retaining wall is proposed along the Borriskane Road frontage, where the ultimate integration of the pedestrian facilities along the site frontage will be subject to the future City EA for the corridor. Connections to the sidewalk on Flagstaff Drive and to the corner of Flagstaff Drive at Borriskane Road are proposed to access on-site pedestrian facilities between buildings.

The infrastructure TDM checklist is provided in Appendix H.

5.2 Circulation and Access

Access is provided via Flagstaff Drive at a new private approach. The approach will be all-movements with a 6.7-metre-wide drive aisle and a throat length of approximately 27 metres. Garbage facilities are located in the northeast corner of the site and are accessed from the main drive aisle. Turning templates demonstrating this operation are provided in Appendix I.

6 Parking

6.1 Parking Supply

The site provides 68 vehicle parking spaces, including one Type A and one Type B barrier free parking space, and six bicycle parking spaces. The minimum parking provision from the zoning by-law is 47 vehicle spaces and six bicycle parking spaces. Site parking is proposed as meeting the minimum zoning by-law requirements.

7 Access Intersections Design

7.1 Location and Design of Access

The site access will connect to Flagstaff Drive, requiring a minimum throat length of 8 metres, per TAC Geometric Design Guidelines for a collector road. The provided 27-metre throat length meets this requirement. The site access is proposed to meet City standard SC7.1 with functional radii of 5.0 metres.

Overall, no concerns are noted with the proposed access location.

8 Transportation Demand Management

8.1 Context for TDM

The mode shares used within the TIA represent auto modes and active mode trips within the area. Overall, the modal shares are likely to be achieved and supporting TDM measures should be provided.

8.2 Need and Opportunity

The subject site has been assumed to rely predominantly on auto travel with an increase to active modes as the adjacent residential lands are completed.

8.3 TDM Program

The “suite of post occupancy TDM measures” has been summarized in the TDM checklists for the residential land uses. The checklist is provided in Appendix H. The key TDM measures recommended include:

- Provide a multimodal travel option package to new/relocating employees
- Provide a permanent bike repair station, with commonly used tools and an air pump, adjacent to the main bicycle parking area

9 Summary of Improvements Indicated and Modifications Options

The following summarizes the analysis and results presented in this TIA report:

Proposed Site and Screening

- The proposed site includes two retail buildings with a total of 14,631 sq. ft. of floor area
- Access will be provided to Flagstaff Drive
- The development is proposed to be completed as a single phase by 2025
- The trip and safety triggers were met for the TIA Screening, although the inclusion of the site in the adjacent subdivision TIA would preclude the trip generation trigger

Existing Conditions

- Borrisokane Road and Cambrian Road are arterial roads, and Flagstaff Drive and Apolune Street are collector roads in the study area
- Sidewalks are provided along both sides of Apolune Street, on both sides of Flagstaff Drive east of Cygnus Street, and on the south side of Flagstaff Drive to the west
- An intersection design is currently underway for a southbound left-turn lane on Borrisokane Road to Flagstaff Drive
- Signalization is planned for the intersections of Cambrian Road at Apolune Street/Elevation Road
- Intersection modifications are planned for the intersection of Cambrian Road at Borrisokane Road
- The existing study area intersections operate well
- Collision types are typical of the roadway contexts, and may improve once the area develops and planned intersection modifications are implemented

Development Generated Travel Demand

- The proposed development is forecasted produce 27 primary two-way people trips during the AM peak hour and 74 primary two-way people trips during the PM peak hour
- The site is anticipated to generate approximately ten fewer AM and six additional PM peak hour two-way primary auto trips than assumed within the Half Moon Bay West Phase 3 subdivision TIA
- Additional pass-by trips of 15 AM and 38 PM peak hour two-way vehicles are forecast as a result of the site
- Overall, the change in trip generation does not require further analysis
- No change is anticipated for the background conditions previously completed in this area, as part of the Half Moon Bay West Phase 3 subdivision TIA and Halo Car Wash site

Development Design

- The proposed development is a retail development with surface parking for both automobiles and bicycles
- The proposed development pedestrian facilities will connect to the planned sidewalk on Flagstaff Drive

Parking

- The site provides a total of 68 vehicle surface parking spaces, including 2 barrier free parking spaces, and 6 bicycle parking spaces
- The minimum parking requirements from the zoning by-law are satisfied

Access Intersections Design

- A single 6.7-metre-wide access is proposed on Flagstaff Drive
- The access will provide sufficient throat length to meet TAC requirements on a collector road
- The access will require a depressed curb and sidewalk through the access per City specification SC7.1 with functional 5.0-metre radii
- The access is assumed to be minor stop-controlled

TDM

- Supportive TDM measures to be included within the proposed development should include:
 - Provide a multimodal travel option package to new/relocating employees
 - Provide a permanent bike repair station, with commonly used tools and an air pump, adjacent to the main bicycle parking area

10 Conclusion

It is recommended that, from a transportation perspective, the proposed development applications proceed.

Prepared By:

Reviewed By:



John Kingsley, EIT
Transportation Engineering Intern



Andrew Harte, P.Eng.
Senior Transportation Engineer

Appendix A

TIA Screening Form and PM Certification Form

City of Ottawa 2017 TIA Guidelines
Step 1 - Screening Form

Date: 04-Oct-22
Project Number: 2022-136
Project Reference: 3387 Borrisokane

1.1 Description of Proposed Development	
Municipal Address	3387 Borrisokane Rd
Description of Location	Parcel on northeast corner of intersection of Borrisokane Rd and Flagstaff Dr
Land Use Classification	Local Commercial (LC[1694])
Development Size	14,747 sq.ft.
Accesses	Single full moves access on Flagstaff Dr
Phase of Development	Single phase
Buildout Year	2025
TIA Requirement	Full TIA Required

1.2 Trip Generation Trigger		
Land Use Type	Local retail	
Development Size	14,747	G.F.A.
Trip Generation Trigger	Yes	

1.3 Location Triggers	
Does the development propose a new driveway to a boundary street that is designated as part of the City's Transit Priority, Rapid Transit or Spine Bicycle Networks?	No
Is the development in a Design Priority Area (DPA) or Transit-oriented Development (TOD) zone?	No
Location Trigger	No

1.4. Safety Triggers		
Are posted speed limits on a boundary street 80 km/hr or greater?	Yes	Borrisokane Rd currently 80 km/h
Are there any horizontal/vertical curvatures on a boundary street limits sight lines at a proposed driveway?	No	
Is the proposed driveway within the area of influence of an adjacent traffic signal or roundabout (i.e. within 300 m of intersection in rural conditions, or within 150 m of intersection in urban/ suburban conditions)?	No	
Is the proposed driveway within auxiliary lanes of an intersection?	No	
Does the proposed driveway make use of an existing median break that serves an existing site?	No	
Is there is a documented history of traffic operations or safety concerns on the boundary streets within 500 m of the development?	No	
Does the development include a drive-thru facility?	No	
Safety Trigger	Yes	No access proposed on Borrisokane Rd. Not recommended to warrant TIA based on Safety Trigger



TIA Plan Reports

On 14 June 2017, the Council of the City of Ottawa adopted new Transportation Impact Assessment (TIA) Guidelines. In adopting the guidelines, Council established a requirement for those preparing and delivering transportation impact assessments and reports to sign a letter of certification.

Individuals submitting TIA reports will be responsible for all aspects of development-related transportation assessment and reporting, and undertaking such work, in accordance and compliance with the City of Ottawa's Official Plan, the Transportation Master Plan and the Transportation Impact Assessment (2017) Guidelines.

By submitting the attached TIA report (and any associated documents) and signing this document, the individual acknowledges that s/he meets the four criteria listed below.

CERTIFICATION

1. I have reviewed and have a sound understanding of the objectives, needs and requirements of the City of Ottawa's Official Plan, Transportation Master Plan and the Transportation Impact Assessment (2017) Guidelines;
2. I have a sound knowledge of industry standard practice with respect to the preparation of transportation impact assessment reports, including multi modal level of service review;
3. I have substantial experience (more than 5 years) in undertaking and delivering transportation impact studies (analysis, reporting and geometric design) with strong background knowledge in transportation planning, engineering or traffic operations; and
4. I am either a licensed¹ or registered² professional in good standing, whose field of expertise [check appropriate field(s)] is either transportation engineering or transportation planning .

1,2 License of registration body that oversees the profession is required to have a code of conduct and ethics guidelines that will ensure appropriate conduct and representation for transportation planning and/or transportation engineering works.

City Of Ottawa
Infrastructure Services and Community
Sustainability
Planning and Growth Management
110 Laurier Avenue West, 4th fl.
Ottawa, ON K1P 1J1
Tel. : 613-580-2424
Fax: 613-560-6006

Ville d'Ottawa
Services d'infrastructure et Viabilité des
collectivités
Urbanisme et Gestion de la croissance
110, avenue Laurier Ouest
Ottawa (Ontario) K1P 1J1
Tél. : 613-580-2424
Télécopieur: 613-560-6006

Dated at Ottawa this 20 day of September, 2018.
(City)

Name: Andrew Harte
(Please Print)

Professional Title: Professional Engineer

Signature of Individual certifier that s/he meets the above four criteria

Office Contact Information (Please Print)
Address: 6 Plaza Court
City / Postal Code: Ottawa / K2H 7W1
Telephone / Extension: (613) 697-3797
E-Mail Address: Andrew.Harte@CGHTransportation.com



Appendix B

Turning Movement Count Data

2.2.6 Existing Area Traffic Management Measures

There are no existing area traffic management measures within the study area.

2.2.7 Existing Peak Hour Travel Demand

Existing turning movement counts were acquired from the Tamarack Meadows Phase 5 TIA (IBI, 2018) for the existing study area intersection. To contextualize these volumes and to grow them to 2019 values, in line with the 3713 Borrisokane Road TIA (CGH, 2019), these volumes were balanced with counts from Barnsdale Road & Borrisokane. While providing context, this intersection will not be analyzed within this report. Table 1 summarizes the intersection count dates and sources.

Table 1: Intersection Count Date

Intersection	Count Date	Data Source
Cambrian Road & Borrisokane Road	Tuesday February 15, 2018	Meadows Phase 5 TIA
Barnsdale Road & Borrisokane Road	Thursday, January 10, 2019	City of Ottawa

Figure 7 illustrates the 2019 existing traffic counts and Table 2 summarizes the existing intersection operations. The level of service is based on the HCM 2010 criteria for average delay at unsignalized. Detailed turning movement count data is included in Appendix B and the synchro worksheets are provided in Appendix C.

Figure 7: Existing Traffic Counts

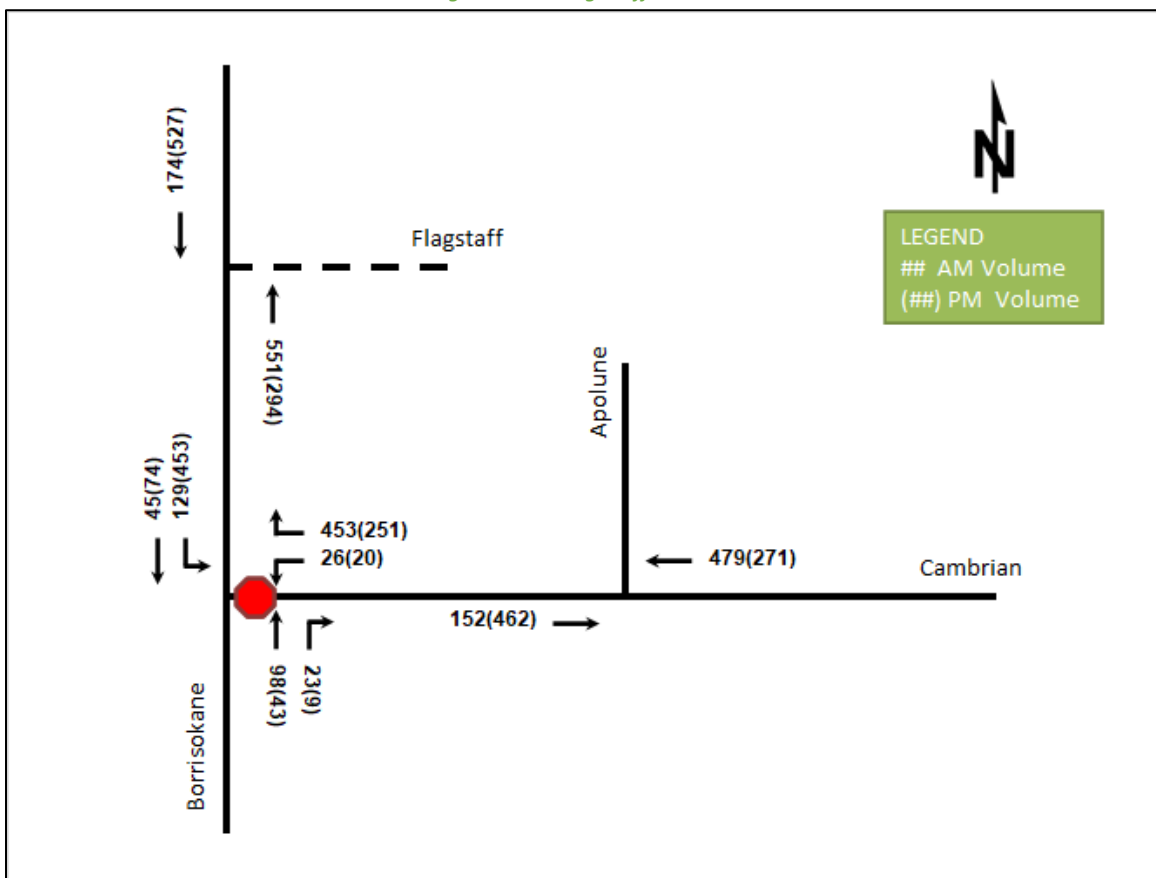

2.2.7 Existing Peak Hour Travel Demand

Existing turning movement counts were acquired from the Tamarack Meadows Phase 5 TIA (IBI, 2018) for the existing study area intersection. To contextualize these volumes and to grow them to 2019 values, in line with the 3713 Borrisokane Road TIA (CGH, 2019), these volumes were balanced with counts from Barnsdale Road & Borrisokane. While providing context, this intersection will not be analyzed within this report. Table 1 summarizes the intersection count dates and sources.

Table 1: Intersection Count Date

Intersection	Count Date	Data Source
Cambrian Road & Borrisokane Road	Tuesday February 15, 2018	Meadows Phase 5 TIA
Barnsdale Road & Borrisokane Road	Thursday, January 10, 2019	City of Ottawa

Figure 7 illustrates the 2019 existing traffic counts and Table 2 summarizes the existing intersection operations. The level of service is based on the HCM 2010 criteria for average delay at unsignalized. Detailed turning movement count data is included in Appendix B and the synchro worksheets are provided in Appendix C.

Figure 7: Existing Traffic Counts

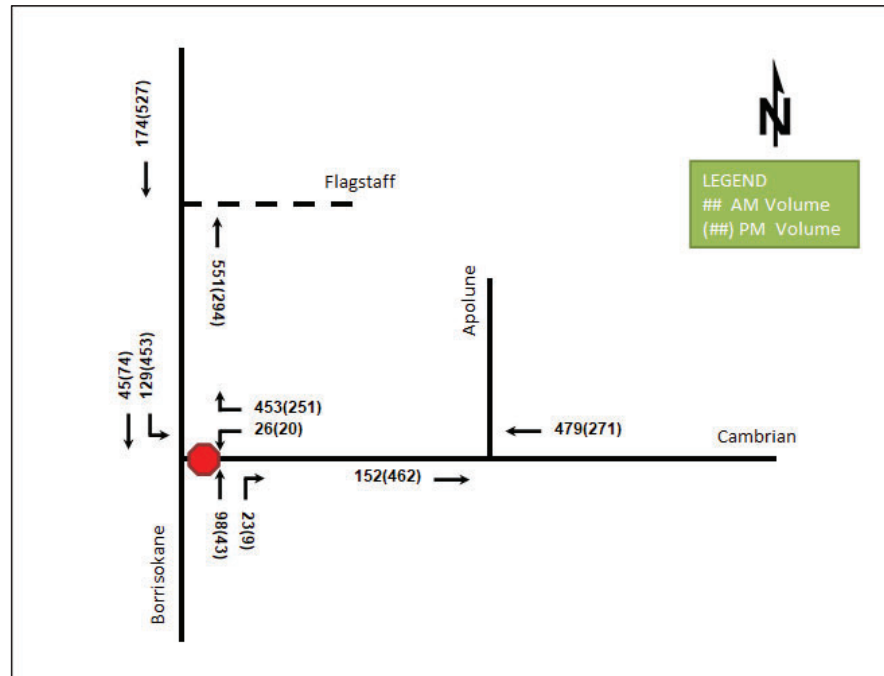

Survey Date: Tuesday February 15 2018
 Weather: Cloudy

TURNING MOVEMENT COUNT SUMMARY - ALL MODES



AM Peak Hour: 7:30 AM to 8:30 AM
 MD Peak Hour: 11:30 AM to 12:30 PM
 PM Peak Hour: 4:45 PM to 5:45 PM

AADT FACTOR: 1.0

Turning Movement Count - Full Study Summary Report (Vehicles)

Time Period	Borrisokane Road					Borrisokane Road					N/S STREET TOTAL	0					Cambrian Road					E/W STREET TOTAL	Grand TOTAL
	Northbound					Southbound						Eastbound					Westbound						
	LT	ST	RT	U-Turns	NB TOTAL	LT	ST	RT	U-Turns	SB TOTAL		LT	ST	RT	U-Turns	EB TOTAL	LT	ST	RT	U-Turns	WB TOTAL		
7:00 8:00	0	28	10	0	38	72	15	0	0	87	125	0	0	0	0	0	8	0	350	0	358	358	483
8:00 9:00	0	48	13	0	61	123	22	0	0	145	206	0	0	0	0	0	5	0	346	0	351	351	557
9:00 10:00	0	24	1	0	25	60	22	0	0	82	107	0	0	0	0	0	1	0	209	0	210	210	317
AVG AM Pk HR	0	33	8	0	41	85	20	0	0	105	146	0	0	0	0	0	5	0	302	0	306	306	452
11:30 12:30	0	54	9	0	63	105	26	0	0	131	194	0	0	0	0	0	4	0	139	0	143	143	337
12:30 13:30	0	48	6	0	54	87	23	0	0	110	164	0	0	0	0	0	2	0	117	0	119	119	283
AVG MD Pk HR	0	51	8	0	59	96	25	0	0	121	179	0	0	0	0	0	3	0	128	0	131	131	310
15:00 16:00	0	40	1	0	41	58	51	0	0	109	150	0	0	0	0	0	13	0	159	0	172	172	322
16:00 17:00	0	25	0	0	25	344	43	0	0	387	412	0	0	0	0	0	11	0	162	0	173	173	585
17:00 18:00	0	22	0	0	22	352	36	0	0	388	410	0	0	0	0	0	14	0	198	0	212	212	622
AVG PM Pk HR	0	29	0	0	29	251	43	0	0	295	324	0	0	0	0	0	13	0	173	0	186	186	510
TOTAL	0	373	56	0	429	1,382	282	0	0	1,664	2,093	0	0	0	0	0	66	0	2,110	0	2,175	2,175	4,268
EQ 12Hr	0	519	77	0	596	1921	392	0	0	2313	2909	0	0	0	0	0	91	0	2932	0	3024	3024	5933
Note: These volumes are calculated by multiplying the totals by the appropriate expansion factor.											1.39												
AVG 12Hr	0	519	77	0	596	1921	392	0	0	2313	2909	0	0	0	0	0	91	0	2932	0	3024	3024	5933
Note: These volumes are calculated by multiplying the Equivalent 12 hr. totals by the AADT factor.											1.0												
AVG 24Hr	0	680	101	0	781	2516	514	0	0	3030	3811	0	0	0	0	0	120	0	3841	0	3961	3961	7772
Note: These volumes are calculated by multiplying the Average Daily 12hr. totals by the 12 to 24 expansion factor.											1.31												

Turning Movement Count - Full Study Summary Report (Pedestrians)

Time Period	Borrisokane Road		Borrisokane Road		N/S STREET TOTAL	0		Cambrian Road		E/W STREET TOTAL	Grand TOTAL
	NB Approach (East or West Crossing)		SB Approach (East or West Crossing)			EB Approach (North or South Crossing)		WB Approach (North or South Crossing)			
7:00 8:00	0		0		0	0		0		0	0
8:00 9:00	0		0		0	0		0		0	0
9:00 10:00	0		0		0	0		1		1	1
11:30 12:30	0		0		0	0		0		0	0
12:30 13:30	0		0		0	0		0		0	0
15:00 16:00	0		0		0	0		0		0	0
16:00 17:00	0		228		228	0		0		0	228
17:00 18:00	0		0		0	0		0		0	0
TOTAL:	0		228		228	0		1		1	229

Turning Movement Count - Full Study Summary Report (Cyclists)

Time Period	Borrisokane Road		N/S STREET TOTAL	0		Cambrian Road		E/W STREET TOTAL	Grand TOTAL
	Northbound	Southbound		Eastbound	Westbound				
7:00 8:00	0	0	0	0	0	0	0	0	
8:00 9:00	0	0	0	0	0	0	0	0	
9:00 10:00	0	0	0	0	0	0	0	0	
11:30 12:30	0	0	0	0	0	0	0	0	
12:30 13:30	0	0	0	0	0	0	0	0	
15:00 16:00	0	0	0	0	0	0	0	0	
16:00 17:00	0	0	0	0	0	0	0	0	
17:00 18:00	0	0	0	0	0	0	0	0	
TOTAL:	0	0	0	0	0	0	0	0	

Turning Movement Count - Full Study Summary Report (Heavy Vehicles)

Time Period	Borrisokane Road					N/S STREET TOTAL	0					E/W STREET TOTAL	Grand TOTAL										
	Northbound						Southbound							Eastbound					Westbound				
	LT	ST	RT	U-Turns	NB TOTAL		LT	ST	RT	U-Turns	SB TOTAL			LT	ST	RT	U-Turns	EB TOTAL	LT	ST	RT	U-Turns	WB TOTAL
7:00 8:00	0	9	0	0	9	16	8	0	0	24	33	0	0	0	0	0	0	5	0	5	5	38	
8:00 9:00	0	10	2	0	12	4	10	0	0	14	26	0	0	0	0	0	2	0	16	0	18	18	44
9:00 10:00	0	12	0	0	12	7	13	0	0	20	32	0	0	0	0	0	0	0	10	0	10	10	42
11:30 12:30	0	11	1	0	12	2	11	0	0	13	25	0	0	0	0	0	1	0	5	0	6	6	31
12:30 13:30	0	10	3	0	13	2	11	0	0	13	26	0	0	0	0	0	0	0	5	0	5	5	31
15:00 16:00	0	2	0	0	2	10	2	0	0	12	14	0	0	0	0	0	1	0	11	0	12	12	26
16:00 17:00	0	1	5	0	6	6	2	0	0	8	14	0	0	0	0	0	4	0	17	0	21	21	35
17:00 18:00	0	2	1	0	3	1	1	0	0	2	5	0	0	0	0	0	2	0	5	0	7	7	12
TOTAL:	0	57	12	0	69	48	58	0	0	106	175	0	0	0	0	0	10	0	74	0	84	84	259



Transportation Services - Traffic Services

Turning Movement Count - Peak Hour Diagram

BARNSDALE RD E @ CEDARVIEW RD E

Survey Date: Thursday, January 10, 2019
Start Time: 07:00

WO No: 38246
Device: Miovision

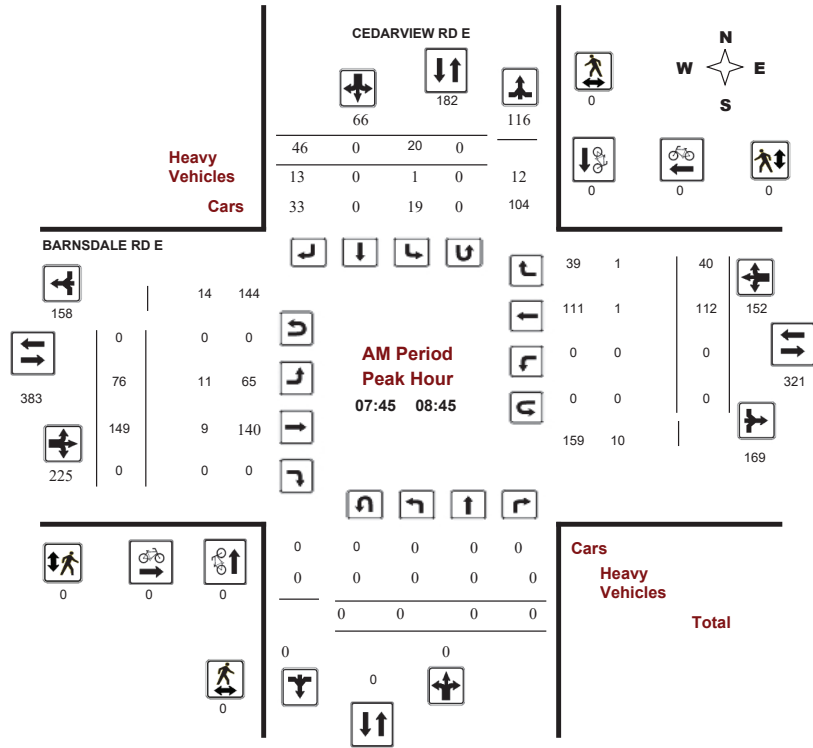

Comments



Transportation Services - Traffic Services

Turning Movement Count - Peak Hour Diagram

BARNSDALE RD E @ CEDARVIEW RD E

Survey Date: Thursday, January 10, 2019
Start Time: 07:00

WO No: 38246
Device: Miovision

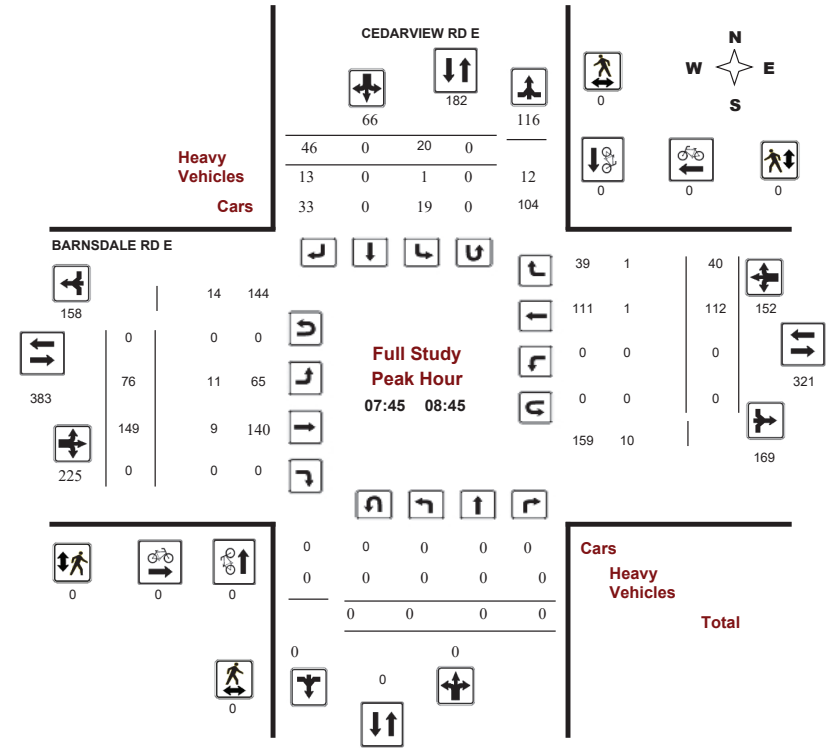

Comments



Transportation Services - Traffic Services

Turning Movement Count - Peak Hour Diagram

BARNSDALE RD E @ CEDARVIEW RD E

Survey Date: Thursday, January 10, 2019
Start Time: 07:00

WO No: 38246
Device: Miovision

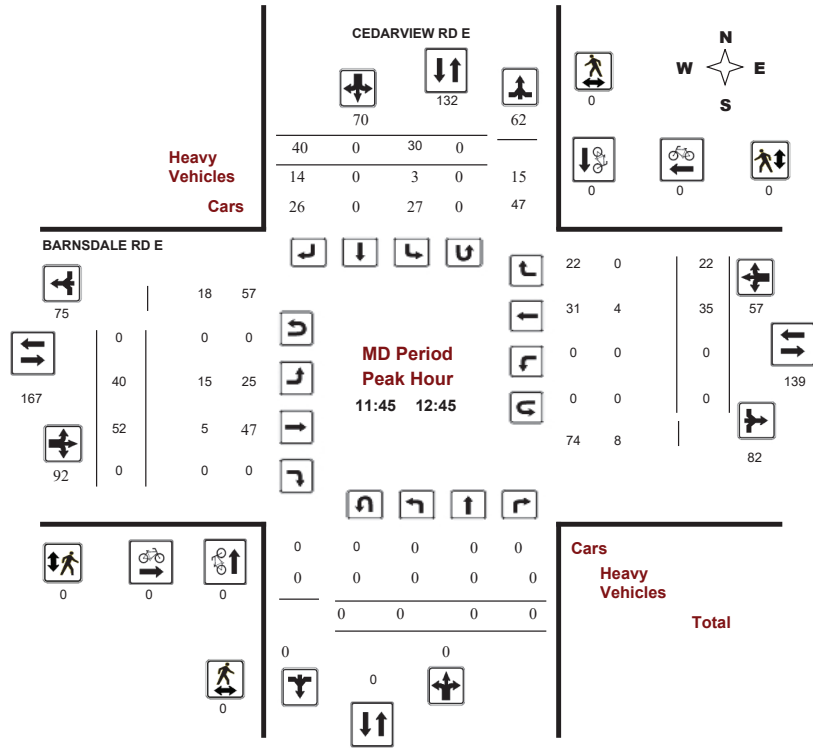

Comments



Transportation Services - Traffic Services

Turning Movement Count - Peak Hour Diagram

BARNSDALE RD E @ CEDARVIEW RD E

Survey Date: Thursday, January 10, 2019
Start Time: 07:00

WO No: 38246
Device: Miovision

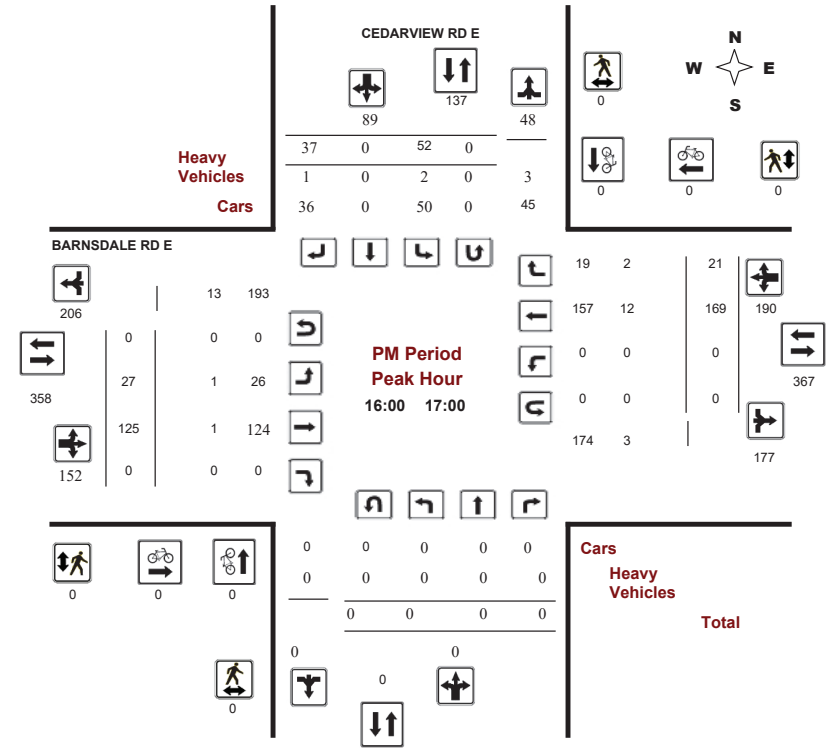

Comments



Transportation Services - Traffic Services
Turning Movement Count - Full Study Diagram

BARNSDALE RD E @ CEDARVIEW RD E

Survey Date: Thursday, January 10, 2019

WO#: 38246
 Device: Miovision

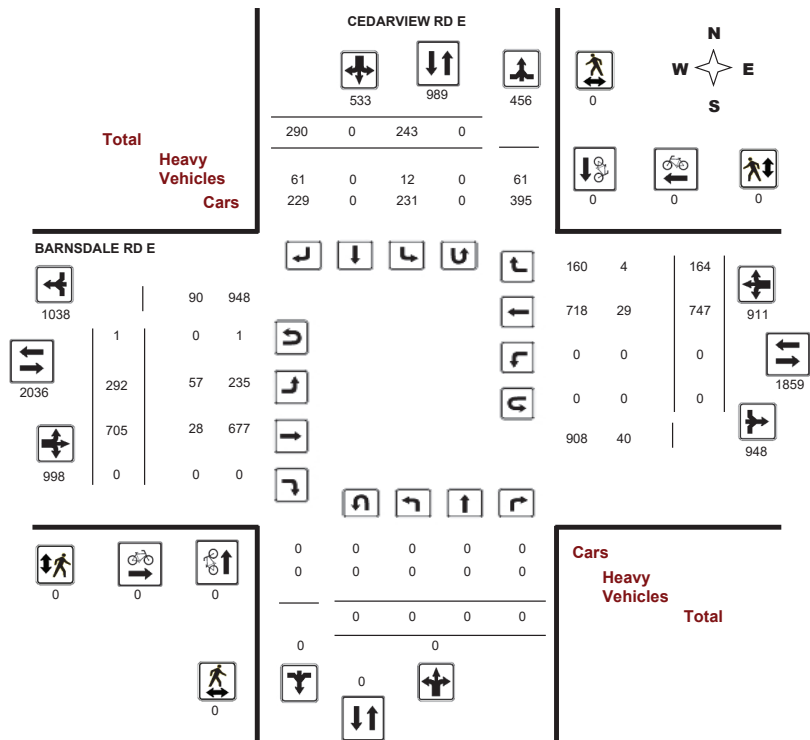

Transportation Services - Traffic Services

Work Order
38246

Turning Movement Count - Full Study Summary Report

BARNSDALE RD E @ CEDARVIEW RD E

Survey Date: Thursday, January 10, 2019

Total Observed U-Turns

AADT Factor

Northbound: 0	Southbound: 0	1.00
Eastbound: 1	Westbound: 0	

Full Study

Period	CEDARVIEW RD E								BARNSDALE RD E								Grand Total		
	Northbound				Southbound				Eastbound				Westbound						
	LT	ST	RT	NB TOT	LT	ST	RT	SB TOT	STR TOT	LT	ST	RT	EB TOT	LT	ST	RT		WB TOT	STR TOT
07:00 08:00	0	0	0	0	11	0	19	30	30	26	124	0	150	0	85	14	99	249	279
08:00 09:00	0	0	0	0	20	0	51	71	71	77	149	0	226	0	105	37	142	368	439
09:00 10:00	0	0	0	0	19	0	25	44	44	34	58	0	92	0	53	18	71	163	207
11:30 12:30	0	0	0	0	31	0	42	73	73	38	49	0	87	0	38	15	53	140	213
12:30 13:30	0	0	0	0	27	0	37	64	64	37	41	0	78	0	29	21	50	128	192
15:00 16:00	0	0	0	0	53	0	47	100	100	33	57	0	90	0	133	26	159	249	349
16:00 17:00	0	0	0	0	52	0	37	89	89	27	125	0	152	0	169	21	190	342	431
17:00 18:00	0	0	0	0	30	0	32	62	62	20	102	0	122	0	135	12	147	269	331
Sub Total	0	0	0	0	243	0	290	533	533	292	705	0	997	0	747	164	911	1908	2441
U Turns				0				0	0				1				0	1	1
Total	0	0	0	0	243	0	290	533	533	292	705	0	998	0	747	164	911	1909	2442
EQ 12Hr	0	0	0	0	338	0	403	741	741	406	980	0	1387	0	1038	228	1266	2653	3394
Note: These values are calculated by multiplying the totals by the appropriate expansion factor.													1.39						
AVG 12Hr	0	0	0	0	338	0	403	741	741	406	980	0	1387	0	1038	228	1266	2653	3394
Note: These volumes are calculated by multiplying the Equivalent 12 hr. totals by the AADT factor.													1.00						
AVG 24Hr	0	0	0	0	442	0	528	971	971	532	1284	0	1817	0	1360	299	1659	3476	4447
Note: These volumes are calculated by multiplying the Average Daily 12 hr. totals by 12 to 24 expansion factor.													1.31						

Comments:

Note: U-Turns provided for approach totals. Refer to 'U-Turn' Report for specific breakdown.



Transportation Services - Traffic Services W.O. 38246
Turning Movement Count - 15 Minute Summary Report

BARNSDALE RD E @ CEDARVIEW RD E

Survey Date: Thursday, January 10, 2019

Total Observed U-Turns

Northbound: 0 Southbound: 0
 Eastbound: 1 Westbound: 0

Time Period	CEDARVIEW RD E									BARNSDALE RD E									Grand Total
	Northbound			Southbound			Eastbound			Westbound			Eastbound			Westbound			
	LT	ST	RT	N TOT	LT	ST	RT	S TOT	STR TOT	LT	ST	RT	E TOT	LT	ST	RT	W TOT	STR TOT	
07:00 07:15	0	0	0	0	3	0	5	8	8	8	17	0	26	0	9	1	10	36	44
07:15 07:30	0	0	0	0	4	0	4	8	8	2	39	0	41	0	27	2	29	70	78
07:30 07:45	0	0	0	0	1	0	4	5	5	4	35	0	39	0	20	4	24	63	68
07:45 08:00	0	0	0	0	3	0	6	9	9	12	33	0	45	0	29	7	36	81	90
08:00 08:15	0	0	0	0	6	0	6	12	12	27	46	0	73	0	26	11	37	110	122
08:15 08:30	0	0	0	0	5	0	13	18	18	24	41	0	65	0	27	15	42	107	125
08:30 08:45	0	0	0	0	6	0	21	27	27	13	29	0	42	0	30	7	37	79	106
08:45 09:00	0	0	0	0	3	0	11	14	14	13	33	0	46	0	22	4	26	72	86
09:00 09:15	0	0	0	0	6	0	9	15	15	10	14	0	24	0	16	4	20	44	59
09:15 09:30	0	0	0	0	7	0	8	15	15	11	23	0	34	0	12	4	16	50	65
09:30 09:45	0	0	0	0	2	0	6	8	8	8	8	0	16	0	16	6	22	38	46
09:45 10:00	0	0	0	0	4	0	2	6	6	5	13	0	18	0	9	4	13	31	37
11:30 11:45	0	0	0	0	9	0	13	22	22	8	10	0	18	0	9	0	9	27	49
11:45 12:00	0	0	0	0	6	0	8	14	14	12	13	0	25	0	10	4	14	39	53
12:00 12:15	0	0	0	0	6	0	14	20	20	8	11	0	19	0	10	8	18	37	57
12:15 12:30	0	0	0	0	10	0	7	17	17	10	15	0	25	0	9	3	12	37	54
12:30 12:45	0	0	0	0	8	0	11	19	19	10	13	0	23	0	6	7	13	36	55
12:45 13:00	0	0	0	0	7	0	5	12	12	13	10	0	23	0	7	4	11	34	46
13:00 13:15	0	0	0	0	8	0	9	17	17	8	11	0	19	0	6	5	11	30	47
13:15 13:30	0	0	0	0	4	0	12	16	16	6	7	0	13	0	10	5	15	28	44
15:00 15:15	0	0	0	0	9	0	10	19	19	12	11	0	23	0	27	8	35	58	77
15:15 15:30	0	0	0	0	14	0	12	26	26	9	15	0	24	0	31	3	34	58	84
15:30 15:45	0	0	0	0	11	0	15	26	26	6	16	0	22	0	43	8	51	73	99
15:45 16:00	0	0	0	0	19	0	10	29	29	6	15	0	21	0	32	7	39	60	89
16:00 16:15	0	0	0	0	12	0	9	21	21	8	33	0	41	0	42	5	47	88	109
16:15 16:30	0	0	0	0	17	0	6	23	23	8	23	0	31	0	44	5	49	80	103
16:30 16:45	0	0	0	0	12	0	8	20	20	4	39	0	43	0	39	3	42	85	105
16:45 17:00	0	0	0	0	11	0	14	25	25	7	30	0	37	0	44	8	52	89	114
17:00 17:15	0	0	0	0	8	0	9	17	17	6	25	0	31	0	44	3	47	78	95
17:15 17:30	0	0	0	0	3	0	10	13	13	8	39	0	47	0	28	5	33	80	93
17:30 17:45	0	0	0	0	11	0	8	19	19	4	21	0	25	0	37	2	39	64	83
17:45 18:00	0	0	0	0	8	0	5	13	13	2	17	0	19	0	26	2	28	47	60
TOTAL:	0	0	0	0	243	0	290	533	533	292	705	0	998	0	747	164	911	1909	2442

Note: U-Turns are included in Totals.

Comment:



Transportation Services - Traffic Services
Turning Movement Count - Cyclist Volume Report

Work Order
38246

BARNSDALE RD E @ CEDARVIEW RD E

Count Date: Thursday, January 10, 2019

Start Time: 07:00

Time Period	CEDARVIEW RD E			BARNSDALE RD E			Grand Total
	Northbound	Southbound	Street Total	Eastbound	Westbound	Street Total	
07:00 08:00	0	0	0	0	0	0	0
08:00 09:00	0	0	0	0	0	0	0
09:00 10:00	0	0	0	0	0	0	0
11:30 12:30	0	0	0	0	0	0	0
12:30 13:30	0	0	0	0	0	0	0
15:00 16:00	0	0	0	0	0	0	0
16:00 17:00	0	0	0	0	0	0	0
17:00 18:00	0	0	0	0	0	0	0
Total	0	0	0	0	0	0	0

Comment:

Note: These volumes consists of bicycles only (no mopeds or motorcycles) and ARE NOT included in the Turning Movement Count Summary.



Transportation Services - Traffic Services

W.O. 38246

Turning Movement Count - Heavy Vehicle Report

BARNSDALE RD E @ CEDARVIEW RD E

Survey Date: Thursday, January 10, 2019

Table with columns for Time Period, Northbound (LT, ST, RT, N TOT), Southbound (LT, ST, RT, S TOT), Eastbound (LT, ST, RT, E TOT), Westbound (LT, ST, RT, W TOT), STR TOT, and Grand Total. Includes sub-totals for U-Turns and Total.

Heavy Vehicles include Buses, Single-Unit Trucks and Articulated Trucks. Further, they ARE included in the Turning Movement Count Summary.



Transportation Services - Traffic Services

Work Order 38246

Turning Movement Count - Pedestrian Volume Report

BARNSDALE RD E @ CEDARVIEW RD E

Count Date: Thursday, January 10, 2019

Start Time: 07:00

Table with columns for Time Period, NB Approach (E or W Crossing), SB Approach (E or W Crossing), Total, EB Approach (N or S Crossing), WB Approach (N or S Crossing), Total, and Grand Total. Shows pedestrian volume data for various time intervals.

Comment:



Transportation Services - Traffic Services

Work Order
38246

Turning Movement Count - 15 Min U-Turn Total Report

BARNSDALE RD E @ CEDARVIEW RD E

Survey Date: Thursday, January 10, 2019

Time Period	Northbound U-Turn Total	Southbound U-Turn Total	Eastbound U-Turn Total	Westbound U-Turn Total	Total
07:00 07:15	0	0	1	0	1
07:15 07:30	0	0	0	0	0
07:30 07:45	0	0	0	0	0
07:45 08:00	0	0	0	0	0
08:00 08:15	0	0	0	0	0
08:15 08:30	0	0	0	0	0
08:30 08:45	0	0	0	0	0
08:45 09:00	0	0	0	0	0
09:00 09:15	0	0	0	0	0
09:15 09:30	0	0	0	0	0
09:30 09:45	0	0	0	0	0
09:45 10:00	0	0	0	0	0
11:30 11:45	0	0	0	0	0
11:45 12:00	0	0	0	0	0
12:00 12:15	0	0	0	0	0
12:15 12:30	0	0	0	0	0
12:30 12:45	0	0	0	0	0
12:45 13:00	0	0	0	0	0
13:00 13:15	0	0	0	0	0
13:15 13:30	0	0	0	0	0
15:00 15:15	0	0	0	0	0
15:15 15:30	0	0	0	0	0
15:30 15:45	0	0	0	0	0
15:45 16:00	0	0	0	0	0
16:00 16:15	0	0	0	0	0
16:15 16:30	0	0	0	0	0
16:30 16:45	0	0	0	0	0
16:45 17:00	0	0	0	0	0
17:00 17:15	0	0	0	0	0
17:15 17:30	0	0	0	0	0
17:30 17:45	0	0	0	0	0
17:45 18:00	0	0	0	0	0
Total	0	0	1	0	1

Table 1: Intersection Count Date

Intersection	Count Date	Source
Cambrian Road at River Mist Road	Wednesday, October 23, 2019	City of Ottawa
	Saturday, October 15, 2022	The Traffic Specialist
Cambrian Road at Apolune Street	-	Half Moon Bay West CTS (Stantec, 2016)
	Saturday, October 15, 2022	The Traffic Specialist

Figure 9 illustrates the existing traffic counts and Table 2 summarizes the existing intersection operations. Synchro 11 has been used to model the unsignalized intersections and HCM 2010 methodology was used for unsignalized intersection operation. Detailed turning movement count data is included in Appendix B and the Synchro worksheets are provided in Appendix C.

Figure 9: Existing Traffic Counts

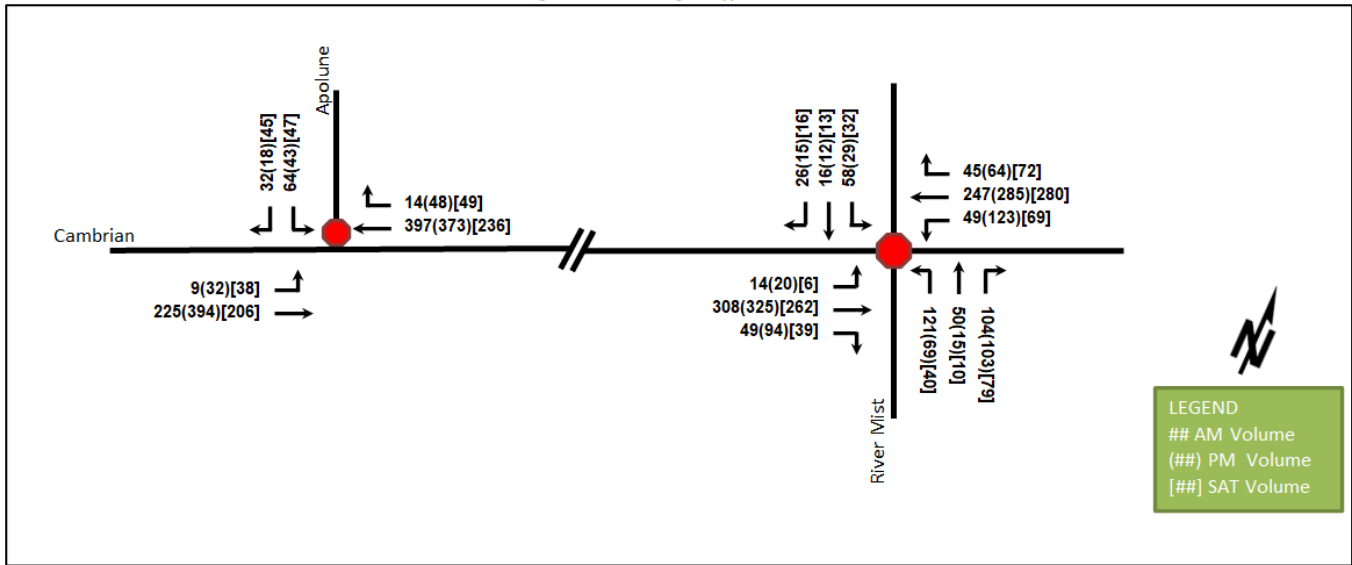

Table 2: Existing Intersection Operations

Intersection	Lane	AM Peak Hour				PM Peak Hour				SAT Peak Hour			
		LOS	V/C	Delay (s)	Q (95 th)	LOS	V/C	Delay (s)	Q (95 th)	LOS	V/C	Delay (s)	Q (95 th)
Cambrian Road at River Mist Road	EB	C	0.71	23.1	43.5	C	0.76	25.0	53.3	B	0.49	13.0	20.3
	WB	C	0.68	21.9	38.3	D	0.82	30.3	66.0	C	0.66	17.4	37.5
	NB	C	0.56	17.5	25.5	B	0.38	13.6	13.5	B	0.23	10.6	6.8
	SB	B	0.23	12.5	6.8	B	0.13	11.4	3.0	B	0.12	10.1	3.0
Unsignalized Overall	C	-	20.3	-	C	-	24.7	-	B	-	14.5	-	
Cambrian Road at Apolune Street	EB	EB	0.01	8.3	0.0	A	0.03	8.4	0.8	A	0.03	8.0	0.8
	WB	-	-	-	-	-	-	-	-	-	-	-	-
	SB	SB	0.25	15.9	6.8	C	0.21	19.1	6.0	B	0.19	13.1	5.3
Unsignalized Overall	A	-	2.2	-	A	-	1.6	-	A	-	2.5	-	

Notes: Saturation flow rate of 1800 veh/h/lane
 Peak Hour Factor = 0.90
 V/C = volume-to-capacity ratio
 Queue is measured in metres

Delay = average vehicle delay in seconds
 m = metered queue
 # = volume for the 95th %ile cycle exceeds capacity

During peak hours in the existing conditions, the study area intersections operate well. No capacity issues are noted.



Turning Movement Count Summary Report Including Peak Hours, AADT and Expansion Factors All Vehicles Except Bicycles



Cambrian Road & Grand Canal Street Barrhaven West, ON

Survey Date: Wednesday, October 19, 2022 Start Time: 0700 AADT Factor: 0.9
 Weather AM: Clear +2° C Survey Duration: 8 Hrs. Survey Hours: 0700-1000, 1130-1330 & 1500-1800
 Weather PM: Overcast 6° C Surveyor(s): T. Carmody

Time Period	Cambrian Rd. Eastbound				Cambrian Rd. Westbound				Grand Canal St. Northbound				Grand Canal St. Southbound				S/B Tot	Street Total	Grand Total				
	LT	ST	RT	UT	LT	ST	RT	UT	LT	ST	RT	UT	LT	ST	RT	UT							
	E/B Tot				W/B Tot				Street Total				N/B Tot										
0700-0800	16	175	30	0	221	17	244	15	0	276	497	98	8	60	0	166	46	4	28	0	78	244	741
0800-0900	32	193	71	0	296	30	246	21	0	297	593	95	64	53	0	212	65	74	45	0	184	396	989
0900-1000	13	174	41	0	228	36	235	17	0	288	516	68	8	47	0	123	37	9	16	0	62	185	701
1130-1230	10	180	40	0	230	28	193	15	0	236	466	39	6	47	0	92	16	7	18	0	41	133	599
1230-1330	19	182	58	0	259	42	213	15	0	270	529	46	1	36	0	83	19	9	17	0	45	128	657
1500-1600	28	245	93	0	366	36	202	29	0	267	633	74	34	49	0	157	46	80	22	0	148	305	938
1600-1700	37	302	105	0	444	62	271	46	0	379	823	56	14	52	0	122	51	17	26	0	94	216	1039
1700-1800	30	308	67	0	405	63	293	43	0	399	804	50	10	51	0	111	34	13	18	0	65	176	980
Totals	185	1759	505	0	2449	314	1897	201	0	2412	4861	526	145	395	0	1066	314	213	190	0	717	1783	6644

Equivalent 12 & 24-hour Vehicle Volumes Including the Annual Average Daily Traffic (AADT) Factor
 Applicable to the Day and Month of the Turning Movement Count
Expansion factors are applied exclusively to standard weekday 8-hour turning movement counts conducted during the hours of 0700h - 1000h, 1130h - 1330h and 1500h - 1800h

Equivalent 12-hour vehicle volumes. These volumes are calculated by multiplying the 8-hour totals by the 8 → 12 expansion factor of 1.39																							
Equ. 12 Hr	257	2445	702	0	3404	436	2637	279	0	3353	6757	731	202	549	0	1482	436	296	264	0	997	2478	9235

Average daily 12-hour vehicle volumes. These volumes are calculated by multiplying the equivalent 12-hour totals by the AADT factor of 0.9																							
AADT 12-hr	231	2201	632	0	3064	393	2373	251	0	3017	6081	658	181	494	0	1334	393	266	238	0	897	2231	8312

24-Hour AADT. These volumes are calculated by multiplying the average daily 12-hour vehicle volumes by the 12 → 24 expansion factor of 1.31																							
AADT 24 Hr	303	2883	828	0	4013	515	3109	329	0	3953	7966	862	238	647	0	1747	515	349	311	0	1175	2922	10888

AADT and expansion factors provided by the City of Ottawa

AM Peak Hour Factor → 0.92													Highest Hourly Vehicle Volume Between 0700h & 1000h												
AM Peak Hr	LT	ST	RT	UT	Total	LT	ST	RT	UT	Total	Str. Tot.	Gr. Tot.	LT	ST	RT	UT	Total	LT	ST	RT	UT	Total	Str. Tot.	Gr. Tot.	
0815-0915	27	209	73	0	309	37	255	21	0	313	622	622	101	64	59	0	224	71	77	43	0	191	415	1037	
OFF Peak Hour Factor → 0.94													Highest Hourly Vehicle Volume Between 1130h & 1330h												
OFF Peak Hr	LT	ST	RT	UT	Total	LT	ST	RT	UT	Total	Str. Tot.	Gr. Tot.	LT	ST	RT	UT	Total	LT	ST	RT	UT	Total	Str. Tot.	Gr. Tot.	
1230-1330	19	182	58	0	259	42	213	15	0	270	529	529	46	1	36	0	83	19	9	17	0	45	128	657	
PM Peak Hour Factor → 0.98													Highest Hourly Vehicle Volume Between 1500h & 1800h												
PM Peak Hr	LT	ST	RT	UT	Total	LT	ST	RT	UT	Total	Str. Tot.	Gr. Tot.	LT	ST	RT	UT	Total	LT	ST	RT	UT	Total	Str. Tot.	Gr. Tot.	
1545-1645	35	282	107	0	424	48	277	42	0	367	791	791	78	25	56	0	159	51	26	20	0	97	256	1047	

Comments:
 OC Transpo and Para Transpo buses, private buses and school buses comprise 28.37% of the heavy vehicle traffic. Some drivers, from each direction, ignored the stop signs and when busy, assessing right-of-way was more difficult. There were 2 vehicle/vehicle conflicts and 1 vehicle/pedestrian conflict during this traffic count. A school crossing guard was present before and after school - primarily assisting pedestrians in the north and west side crossings.

- Notes:**
- Includes all vehicle types except bicycles, electric bicycles, and electric scooters.
 - When expansion and AADT factors are applied, the results will differ slightly due to rounding.



Turning Movement Count Summary, AM and PM Peak Hour Flow Diagrams All Vehicles Except Bicycles



Cambrian Road & Grand Canal Street Barrhaven West, ON

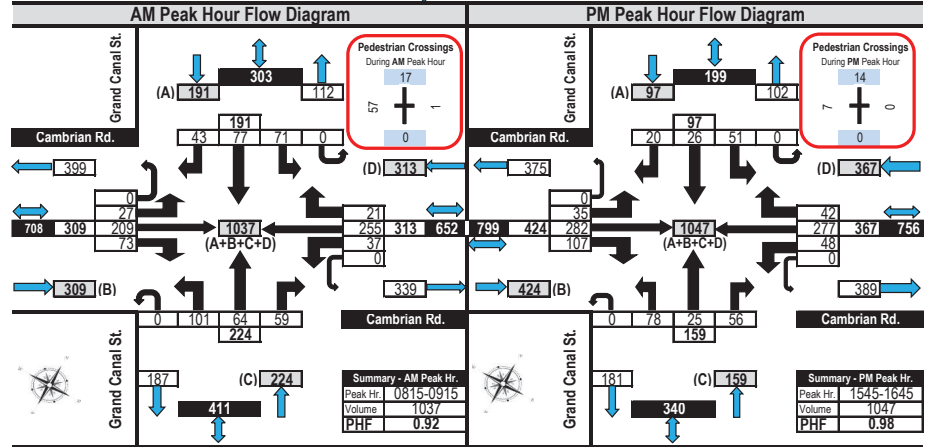
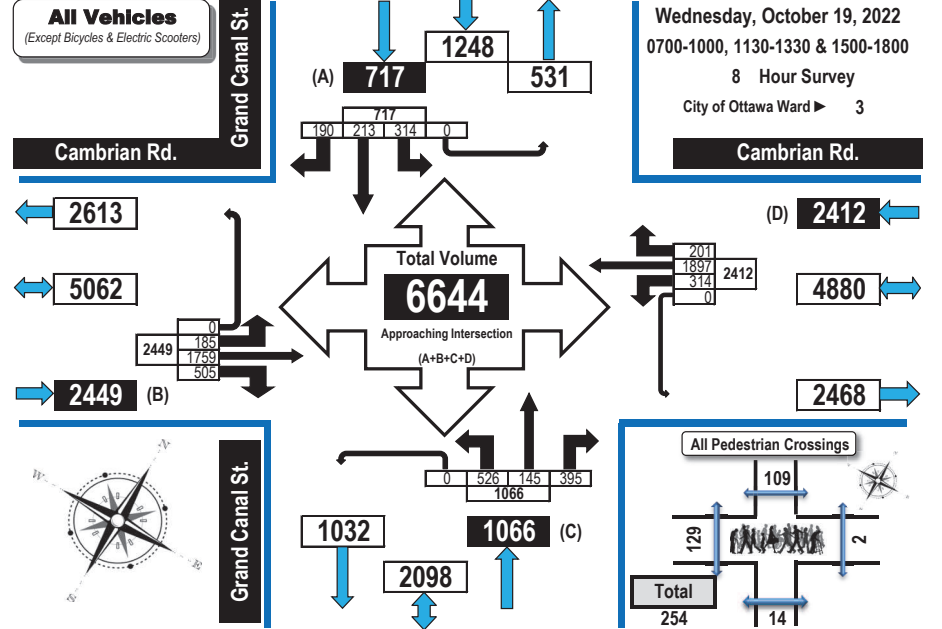



Turning Movement Count Summary, OFF and EVENING Peak Hour Flow Diagrams All Vehicles Except Bicycles

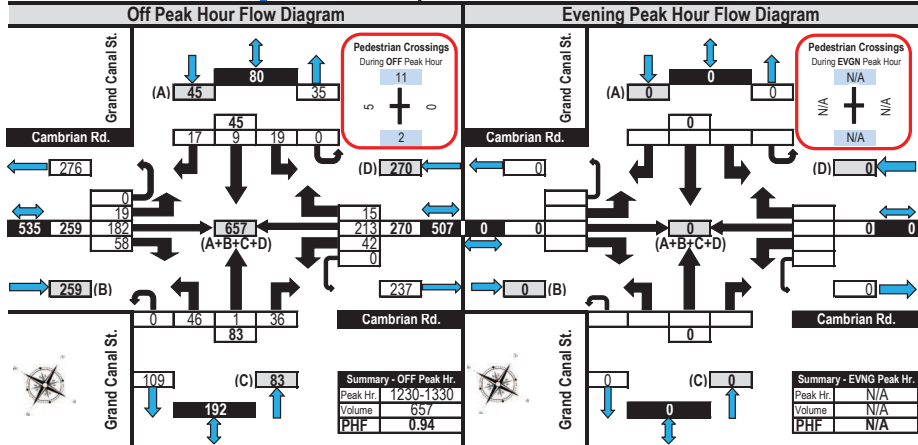
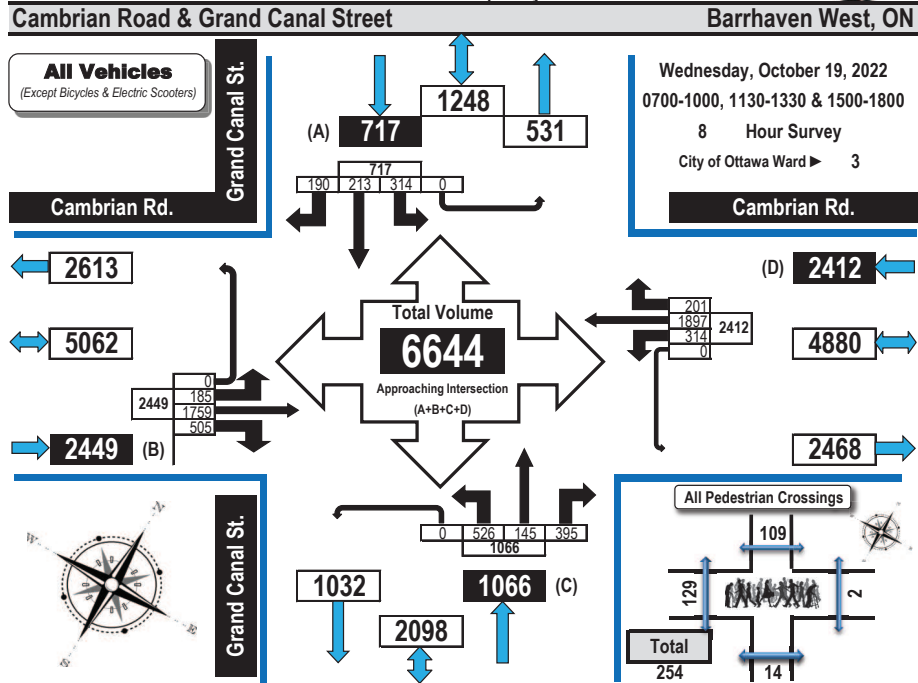

Printed on: 10/21/2022

Prepared by: thetrafficsspecialist@gmail.com

Flow Diagrams: OFF Peak



Turning Movement Count Heavy Vehicle Summary (FHWA Class 4-13) Flow Diagram

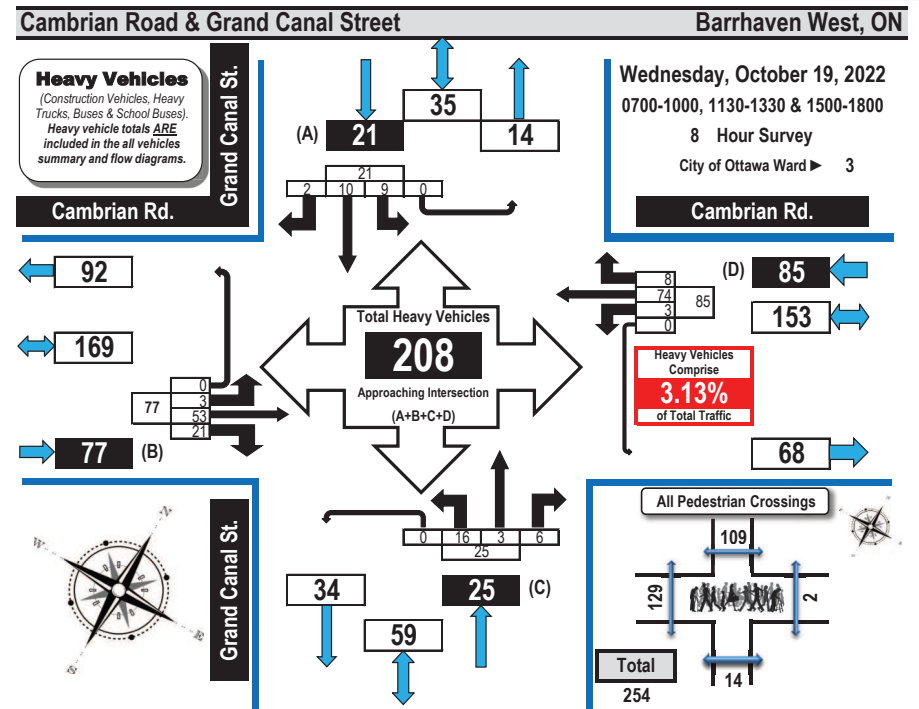

Time Period	Cambrian Rd. Eastbound				Cambrian Rd. Westbound				Grand Canal St. Northbound				Grand Canal St. Southbound				SB Tot	GR Tot			
	LT	ST	RT	UT	EB Tot	LT	ST	RT	UT	WB Tot	LT	ST	RT	UT	NB Tot						
0700-0800	1	7	5	0	13	1	10	1	0	12	1	0	1	0	2	1	0	0	0	1	28
0800-0900	1	5	1	0	7	0	10	2	0	12	5	1	1	0	7	3	2	2	0	7	33
0900-1000	0	8	4	0	12	0	7	1	0	8	0	0	0	0	0	2	1	0	0	3	23
1130-1230	0	7	0	0	7	1	10	1	0	12	1	1	2	0	4	1	1	0	0	2	25
1230-1330	0	4	6	0	10	0	12	0	0	12	1	0	1	0	2	0	2	0	0	2	26
1500-1600	0	8	1	0	9	1	8	2	0	11	6	0	0	0	6	0	3	0	0	3	29
1600-1700	1	10	4	0	15	0	13	1	0	14	2	0	1	0	3	2	1	0	0	3	35
1700-1800	0	4	0	0	4	0	4	0	0	4	0	1	0	0	1	0	0	0	0	0	9
Totals	3	53	21	0	77	3	74	8	0	85	16	3	6	0	25	9	10	2	0	21	208

Comments:

OC Transpo and Para Transpo buses, private buses and school buses comprise 28.37% of the heavy vehicle traffic. Some drivers, from each direction, ignored the stop signs and when busy, assessing right-of-way was more difficult. There were 2 vehicle/vehicle conflicts and 1 vehicle/pedestrian conflict during this traffic count. A school crossing guard was present before and after school - primarily assisting pedestrians in the north and west side crossings.

Printed on: 10/21/2022

Prepared by: thetrafficsspecialist@gmail.com

Summary: Heavy Vehicles



Turning Movement Count All Buses Summary (FHWA Class 4 ONLY) Flow Diagram



Cambrian Road & Grand Canal Street Barrhaven West, ON

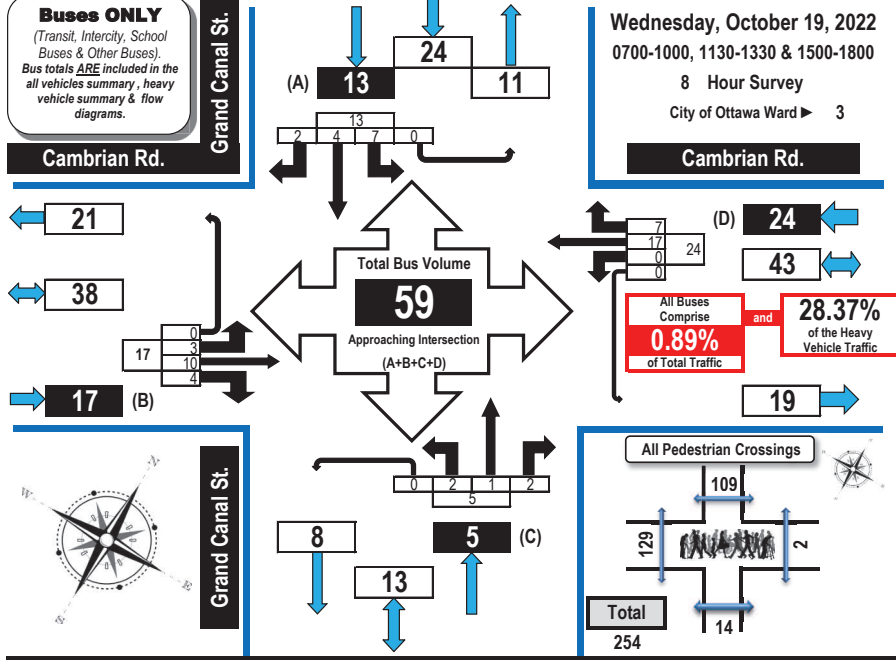

Time Period	Cambrian Rd. Eastbound				Cambrian Rd. Westbound				Grand Canal St. Northbound				Grand Canal St. Southbound				GR Tot				
	LT	ST	RT	UT	EB Tot	LT	ST	RT	UT	WB Tot	LT	ST	RT	UT	NB Tot	LT		ST	RT	UT	SB Tot
0700-0800	1	3	3	0	7	0	3	1	0	4	0	0	1	0	1	1	0	0	0	1	13
0800-0900	1	0	0	0	1	0	4	2	0	6	2	1	1	0	4	2	1	2	0	5	16
0900-1000	0	1	0	0	1	0	2	0	0	2	0	0	0	0	2	0	0	0	0	2	5
1130-1230	0	1	0	0	1	0	0	1	0	1	0	0	0	0	0	0	0	0	0	0	2
1230-1330	0	0	0	0	0	0	0	0	0	0	0	0	0	0	0	0	0	0	0	0	0
1500-1600	0	1	0	0	1	0	2	2	0	4	0	0	0	0	0	2	0	0	0	2	7
1600-1700	1	4	1	0	6	0	5	1	0	6	0	0	0	0	2	1	0	0	3	15	
1700-1800	0	0	0	0	0	0	1	0	0	1	0	0	0	0	0	0	0	0	0	0	1
Totals	3	10	4	0	17	0	17	7	0	24	2	1	2	0	5	7	4	2	0	13	59

Comments:
OC Transpo and Para Transpo buses, private buses and school buses comprise 28.37% of the heavy vehicle traffic. Some drivers, from each direction, ignored the stop signs and when busy, assessing right-of-way was more difficult. There were 2 vehicle/vehicle conflicts and 1 vehicle/pedestrian conflict during this traffic count. A school crossing guard was present before and after school - primarily assisting pedestrians in the north and west side crossings.



Turning Movement Count Bicycle Summary Flow Diagram



Cambrian Road & Grand Canal Street Barrhaven West, ON

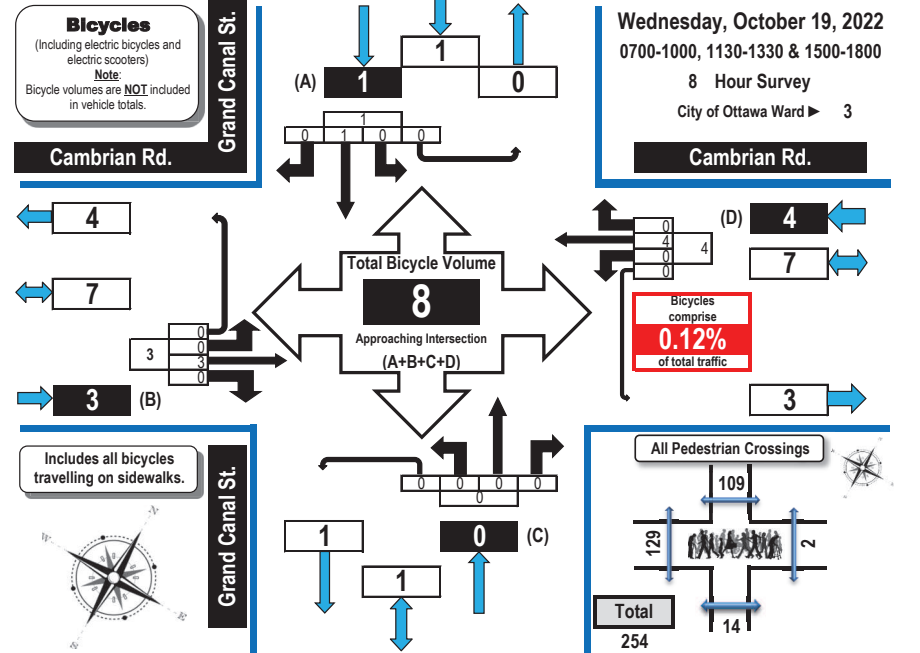

Time Period	Cambrian Rd. Eastbound				Cambrian Rd. Westbound				Grand Canal St. Northbound				Grand Canal St. Southbound				GR Tot				
	LT	ST	RT	UT	EB Tot	LT	ST	RT	UT	WB Tot	LT	ST	RT	UT	NB Tot	LT		ST	RT	UT	SB Tot
0700-0800	0	0	0	0	0	0	0	0	0	0	0	0	0	0	0	0	0	0	0	0	0
0800-0900	0	0	0	0	0	0	0	0	0	0	0	0	0	0	0	0	0	0	0	0	0
0900-1000	0	0	0	0	0	0	0	0	0	0	0	0	0	0	0	0	0	0	0	0	0
1130-1230	0	0	0	0	0	0	0	0	0	0	0	0	0	0	0	0	0	0	0	0	0
1230-1330	0	0	0	0	0	0	0	0	0	0	0	0	0	0	0	0	0	0	0	0	0
1500-1600	0	2	0	0	2	0	3	0	0	3	0	0	0	0	0	0	0	0	0	0	5
1600-1700	0	0	0	0	0	0	1	0	0	1	0	0	0	0	0	0	0	0	0	1	2
1700-1800	0	1	0	0	1	0	0	0	0	0	0	0	0	0	0	0	0	0	0	0	1
Totals	0	3	0	0	3	0	4	0	0	4	0	0	0	0	0	0	0	0	1	8	

Comments:
OC Transpo and Para Transpo buses, private buses and school buses comprise 28.37% of the heavy vehicle traffic. Some drivers, from each direction, ignored the stop signs and when busy, assessing right-of-way was more difficult. There were 2 vehicle/vehicle conflicts and 1 vehicle/pedestrian conflict during this traffic count. A school crossing guard was present before and after school - primarily assisting pedestrians in the north and west side crossings.



Turning Movement Count Pedestrian Crossings Summary and Flow Diagram



Cambrian Road & Grand Canal Street Barrhaven West, ON

Pedestrian Crossings

Wednesday, October 19, 2022
0700-1000, 1130-1330 & 1500-1800
8 Hour Survey
City of Ottawa Ward ▶ 3

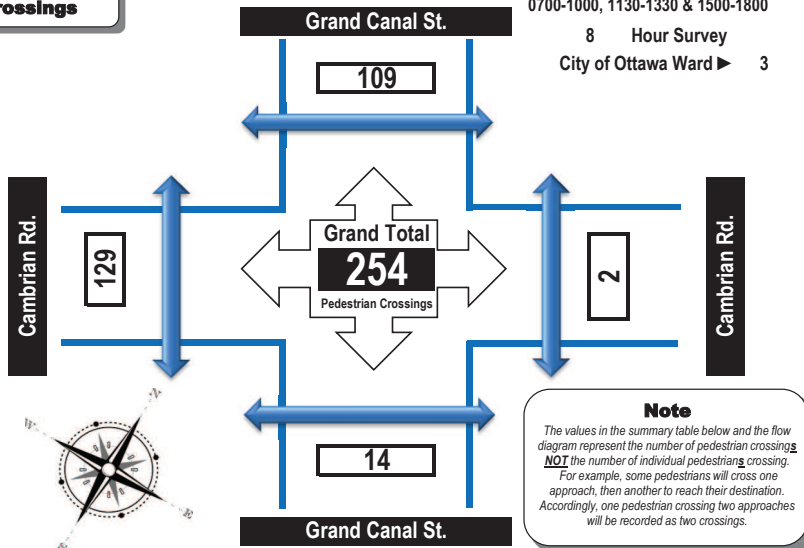

Time Period	West Side Crossing	East Side Crossing	Street Total	South Side Crossing	North Side Crossing	Street Total	Grand Total
	Cambrian Rd.	Cambrian Rd.		Grand Canal St.	Grand Canal St.		
0700-0800	5	0	5	2	19	21	26
0800-0900	57	1	58	1	19	20	78
0900-1000	3	0	3	3	12	15	18
1130-1230	5	0	5	3	10	13	18
1230-1330	5	0	5	2	11	13	18
1500-1600	45	1	46	2	11	13	59
1600-1700	6	0	6	0	9	9	15
1700-1800	3	0	3	1	18	19	22
Totals	129	2	131	14	109	123	254

Comments:

OC Transpo and Para Transpo buses, private buses and school buses comprise 28.37% of the heavy vehicle traffic. Some drivers, from each direction, ignored the stop signs and when busy, assessing right-of-way was more difficult. There were 2 vehicle/vehicle conflicts and 1 vehicle/pedestrian conflict during this traffic count. A school crossing guard was present before and after school - primarily assisting pedestrians in the north and west side crossings.

Appendix C

Synchro Intersection Worksheets – Existing Conditions

HCM 2010 TWSC
1: Borrisokane Road & Cambrian Road

Existing
3387 Borrisokane Rd

Intersection						
Int Delay, s/veh	9.5					
Movement	WBL	WBR	NBT	NBR	SBL	SBT
Lane Configurations	↔		↔			↔
Traffic Vol, veh/h	12	417	53	24	210	20
Future Vol, veh/h	12	417	53	24	210	20
Conflicting Peds, #/hr	0	0	0	0	0	0
Sign Control	Stop	Stop	Free	Free	Free	Free
RT Channelized	-	None	-	None	-	None
Storage Length	0	-	-	-	-	-
Veh in Median Storage, #	0	-	0	-	-	0
Grade, %	0	-	0	-	-	0
Peak Hour Factor	90	90	90	90	90	90
Heavy Vehicles, %	2	2	2	2	2	2
Mvmt Flow	13	463	59	27	233	22

Major/Minor	Minor1	Major1	Major2
Conflicting Flow All	561	73	0 0 86 0
Stage 1	73	-	- - - -
Stage 2	488	-	- - - -
Critical Hdwy	6.42	6.22	- - 4.12 -
Critical Hdwy Stg 1	5.42	-	- - - -
Critical Hdwy Stg 2	5.42	-	- - - -
Follow-up Hdwy	3.518	3.318	- - 2.218 -
Pot Cap-1 Maneuver	489	989	- - 1510 -
Stage 1	950	-	- - - -
Stage 2	617	-	- - - -
Platoon blocked, %	-	-	- - - -
Mov Cap-1 Maneuver	413	989	- - 1510 -
Mov Cap-2 Maneuver	413	-	- - - -
Stage 1	950	-	- - - -
Stage 2	521	-	- - - -

Approach	WB	NB	SB
HCM Control Delay, s	12.5	0	7.1
HCM LOS	B		

Minor Lane/Major Mvmt	NBT	NBRWBLn1	SBL	SBT
Capacity (veh/h)	-	- 952	1510	-
HCM Lane V/C Ratio	-	- 0.501	0.155	-
HCM Control Delay (s)	-	- 12.5	7.8	0
HCM Lane LOS	-	- B	A	A
HCM 95th %tile Q(veh)	-	- 2.9	0.5	-

HCM 2010 TWSC
2: Cambrian Road

Existing
3387 Borrisokane Rd

Intersection						
Int Delay, s/veh	2.1					
Movement	EBL	EBT	WBT	WBR	SBL	SBR
Lane Configurations		↔	↔		↔	
Traffic Vol, veh/h	9	225	397	14	64	32
Future Vol, veh/h	9	225	397	14	64	32
Conflicting Peds, #/hr	0	0	0	0	0	0
Sign Control	Free	Free	Free	Free	Stop	Stop
RT Channelized	-	None	-	None	-	None
Storage Length	-	-	-	-	0	-
Veh in Median Storage, #	-	0	0	-	0	-
Grade, %	-	0	0	-	0	-
Peak Hour Factor	90	90	90	90	90	90
Heavy Vehicles, %	2	2	2	2	2	2
Mvmt Flow	10	250	441	16	71	36

Major/Minor	Major1	Major2	Minor2
Conflicting Flow All	457	0	0 719 449
Stage 1	-	-	- - 449 -
Stage 2	-	-	- - 270 -
Critical Hdwy	4.12	-	- - 6.42 6.22
Critical Hdwy Stg 1	-	-	- - 5.42 -
Critical Hdwy Stg 2	-	-	- - 5.42 -
Follow-up Hdwy	2.218	-	- - 3.518 3.318
Pot Cap-1 Maneuver	1104	-	- - 395 610
Stage 1	-	-	- - 643 -
Stage 2	-	-	- - 775 -
Platoon blocked, %	-	-	- - - -
Mov Cap-1 Maneuver	1104	-	- - 391 610
Mov Cap-2 Maneuver	-	-	- - 391 -
Stage 1	-	-	- - 636 -
Stage 2	-	-	- - 775 -

Approach	EB	WB	SB
HCM Control Delay, s	0.3	0	15.7
HCM LOS			C

Minor Lane/Major Mvmt	EBL	EBT	WBT	WBR	SBLn1
Capacity (veh/h)	1104	-	-	-	444
HCM Lane V/C Ratio	0.009	-	-	-	0.24
HCM Control Delay (s)	8.3	0	-	-	15.7
HCM Lane LOS	A	A	-	-	C
HCM 95th %tile Q(veh)	0	-	-	-	0.9

HCM 2010 TWSC
1: Borrisokane Road & Cambrian Road

Existing
3387 Borrisokane Rd

Intersection						
Int Delay, s/veh	10					
Movement	WBL	WBR	NBT	NBR	SBL	SBT
Lane Configurations	↔		↔			↔
Traffic Vol, veh/h	19	372	41	7	419	40
Future Vol, veh/h	19	372	41	7	419	40
Conflicting Peds, #/hr	0	0	0	0	0	0
Sign Control	Stop	Stop	Free	Free	Free	Free
RT Channelized	-	None	-	None	-	None
Storage Length	0	-	-	-	-	-
Veh in Median Storage, #	0	-	0	-	-	0
Grade, %	0	-	0	-	-	0
Peak Hour Factor	90	90	90	90	90	90
Heavy Vehicles, %	2	2	2	2	2	2
Mvmt Flow	21	413	46	8	466	44

Major/Minor	Minor1	Major1	Major2
Conflicting Flow All	1026	50	0 54 0
Stage 1	50	-	- - -
Stage 2	976	-	- - -
Critical Hdwy	6.42	6.22	- - 4.12 -
Critical Hdwy Stg 1	5.42	-	- - - -
Critical Hdwy Stg 2	5.42	-	- - - -
Follow-up Hdwy	3.518	3.318	- - 2.218 -
Pot Cap-1 Maneuver	260	1018	- - 1551 -
Stage 1	972	-	- - - -
Stage 2	365	-	- - - -
Platoon blocked, %			- - - -
Mov Cap-1 Maneuver	180	1018	- - 1551 -
Mov Cap-2 Maneuver	180	-	- - - -
Stage 1	972	-	- - - -
Stage 2	253	-	- - - -

Approach	WB	NB	SB
HCM Control Delay, s	14	0	7.6
HCM LOS	B		

Minor Lane/Major Mvmt	NBT	NBRWBLn1	SBL	SBT
Capacity (veh/h)	-	- 830	1551	-
HCM Lane V/C Ratio	-	- 0.523	0.3	-
HCM Control Delay (s)	-	- 14	8.3	0
HCM Lane LOS	-	- B	A	A
HCM 95th %tile Q(veh)	-	- 3.1	1.3	-

HCM 2010 TWSC
2: Cambrian Road

Existing
3387 Borrisokane Rd

Intersection						
Int Delay, s/veh	1.5					
Movement	EBL	EBT	WBT	WBR	SBL	SBR
Lane Configurations		↔	↔		↔	
Traffic Vol, veh/h	32	394	373	48	43	18
Future Vol, veh/h	32	394	373	48	43	18
Conflicting Peds, #/hr	0	0	0	0	0	0
Sign Control	Free	Free	Free	Free	Stop	Stop
RT Channelized	-	None	-	None	-	None
Storage Length	-	-	-	-	0	-
Veh in Median Storage, #	-	0	0	-	0	-
Grade, %	-	0	0	-	0	-
Peak Hour Factor	90	90	90	90	90	90
Heavy Vehicles, %	2	2	2	2	2	2
Mvmt Flow	36	438	414	53	48	20

Major/Minor	Major1	Major2	Minor2
Conflicting Flow All	467	0	0 951 441
Stage 1	-	-	- - 441 -
Stage 2	-	-	- - - 510 -
Critical Hdwy	4.12	-	- - 6.42 6.22
Critical Hdwy Stg 1	-	-	- - 5.42 -
Critical Hdwy Stg 2	-	-	- - - 5.42 -
Follow-up Hdwy	2.218	-	- - 3.518 3.318
Pot Cap-1 Maneuver	1094	-	- - 288 616
Stage 1	-	-	- - - 648 -
Stage 2	-	-	- - - 603 -
Platoon blocked, %			- - - -
Mov Cap-1 Maneuver	1094	-	- - 276 616
Mov Cap-2 Maneuver	-	-	- - 276 -
Stage 1	-	-	- - - 620 -
Stage 2	-	-	- - - 603 -

Approach	EB	WB	SB
HCM Control Delay, s	0.6	0	18.7
HCM LOS			C

Minor Lane/Major Mvmt	EBL	EBT	WBT	WBR	SBLn1
Capacity (veh/h)	1094	-	-	-	330
HCM Lane V/C Ratio	0.033	-	-	-	0.205
HCM Control Delay (s)	8.4	0	-	-	18.7
HCM Lane LOS	A	A	-	-	C
HCM 95th %tile Q(veh)	0.1	-	-	-	0.8

Appendix D

Collision Data

Accident Date	Accident Year	Accident Time	Location	Environment Condition	Light	Traffic Control	Traffic Control Condition	Classification Of Accident	Initial Impact Type	Road Surface Condition	# Vehicles	# Motorcycles	# Bicycles	# Pedestrians
2019-10-10	2019	15:43	APOLLUNE ST @ CAMBRIAN RD (0018897)	01 - Clear	01 - Daylight	02 - Stop sign	01 - Functioning	03 - P.D. only	02 - Angle	01 - Dry	2	0	0	0
2020-11-06	2020	12:30	APOLLUNE ST btwn CAMBRIAN RD & NO NAME (e____ITM)	01 - Clear	01 - Daylight	10 - No control	0	03 - P.D. only	05 - Turning movement	01 - Dry	2	0	0	0
2016-12-11	2016	9:30	CAMBRIAN RD @ CEDARVIEW RD (0001571)	01 - Clear	01 - Daylight	02 - Stop sign	01 - Functioning	03 - P.D. only	07 - SMV other	06 - Ice	1	0	0	0
2016-01-30	2016	4:40	CAMBRIAN RD btwn BORRISOKANE RD & GRAND CANAL ST (___7N36UU)	03 - Snow	07 - Dark	10 - No control	0	02 - Non-fatal injury	07 - SMV other	03 - Loose snow	1	0	0	0
2016-06-23	2016	17:10	CAMBRIAN RD @ CEDARVIEW RD (0001571)	01 - Clear	01 - Daylight	02 - Stop sign	01 - Functioning	02 - Non-fatal injury	03 - Rear end	01 - Dry	2	0	0	0
2016-07-29	2016	3:27	CAMBRIAN RD @ CEDARVIEW RD (0001571)	07 - Fog, mist, smoke, dust	07 - Dark	02 - Stop sign	01 - Functioning	03 - P.D. only	03 - Rear end	01 - Dry	2	0	0	0
2016-07-22	2016	20:56	CAMBRIAN RD @ CEDARVIEW RD (0001571)	02 - Rain	05 - Dusk	02 - Stop sign	01 - Functioning	03 - P.D. only	07 - SMV other	02 - Wet	1	0	0	0
2017-12-17	2017	8:33	CAMBRIAN RD @ CEDARVIEW RD (0001571)	01 - Clear	01 - Daylight	02 - Stop sign	01 - Functioning	03 - P.D. only	07 - SMV other	01 - Dry	1	0	0	0
2017-08-29	2017	13:57	CAMBRIAN RD @ CEDARVIEW RD (0001571)	01 - Clear	01 - Daylight	02 - Stop sign	01 - Functioning	03 - P.D. only	03 - Rear end	01 - Dry	2	0	0	0
2018-06-26	2018	11:51	CAMBRIAN RD @ CEDARVIEW RD (0001571)	01 - Clear	01 - Daylight	02 - Stop sign	01 - Functioning	02 - Non-fatal injury	07 - SMV other	08 - Loose sand or gravel	1	1	0	0
2020-02-01	2020	13:49	CAMBRIAN RD @ CEDARVIEW RD (0001571)	01 - Clear	01 - Daylight	02 - Stop sign	01 - Functioning	02 - Non-fatal injury	03 - Rear end	02 - Wet	2	0	0	0
2020-01-07	2020	22:24	CAMBRIAN RD @ CEDARVIEW RD (0001571)	03 - Snow	07 - Dark	02 - Stop sign	01 - Functioning	02 - Non-fatal injury	03 - Rear end	02 - Wet	2	0	0	0
2020-01-10	2020	17:16	CAMBRIAN RD @ CEDARVIEW RD (0001571)	02 - Rain	05 - Dusk	02 - Stop sign	01 - Functioning	02 - Non-fatal injury	02 - Angle	02 - Wet	2	0	0	0
2020-10-14	2020	18:25	CAMBRIAN RD @ CEDARVIEW RD (0001571)	01 - Clear	05 - Dusk	02 - Stop sign	01 - Functioning	03 - P.D. only	03 - Rear end	01 - Dry	2	0	0	0
2020-12-24	2020	12:45	CAMBRIAN RD @ CEDARVIEW RD (0001571)	01 - Clear	01 - Daylight	02 - Stop sign	01 - Functioning	03 - P.D. only	05 - Turning movement	02 - Wet	2	0	0	0



Transportation Services - Traffic Services

Collision Details Report - Public Version

From: January 1, 2016 To: December 31, 2020

Location: BOOTH ST @ RAYMOND ST

Traffic Control: Traffic signal

Total Collisions: 19

Date/Day/Time	Environment	Impact Type	Classification	Surface Cond'n	Veh. Dir	Vehicle Manoeuver	Vehicle type	First Event	No. Ped
2019-Mar-16, Sat,11:51	Clear	Sideswipe	P.D. only	Wet	West	Going ahead	Automobile, station wagon	Other motor vehicle	0
					West	Changing lanes	Automobile, station wagon	Other motor vehicle	
2019-Jun-09, Sun,10:50	Clear	Other	P.D. only	Dry	East	Reversing	Truck - open	Other motor vehicle	0
					West	Stopped	Automobile, station wagon	Other motor vehicle	
2019-Sep-27, Fri,15:42	Clear	Sideswipe	P.D. only	Dry	West	Changing lanes	Automobile, station wagon	Other motor vehicle	0
					West	Going ahead	Truck - car carrier	Other motor vehicle	
2020-Jan-13, Mon,17:08	Clear	Sideswipe	P.D. only	Wet	North	Turning left	Automobile, station wagon	Other motor vehicle	0
					North	Turning left	School bus	Other motor vehicle	
2020-Jul-03, Fri,07:30	Clear	SMV other	P.D. only	Dry	West	Turning right	Truck and trailer	Pole (utility, power)	0
2020-Jul-15, Wed,08:29	Clear	Angle	Non-fatal injury	Dry	North	Going ahead	Automobile, station wagon	Other motor vehicle	0
					West	Going ahead	Automobile, station wagon	Other motor vehicle	
2020-Nov-10, Tue,18:14	Clear	Angle	P.D. only	Dry	North	Going ahead	Automobile, station wagon	Other motor vehicle	0
					West	Going ahead	Automobile, station wagon	Other motor vehicle	

Location: BORRISOKANE RD @ CAMBRIAN RD

Traffic Control: Stop sign

Total Collisions: 12

Date/Day/Time	Environment	Impact Type	Classification	Surface Cond'n	Veh. Dir	Vehicle Manoeuver	Vehicle type	First Event	No. Ped
2016-Jun-23, Thu,17:10	Clear	Rear end	Non-fatal injury	Dry	South	Going ahead	Pick-up truck	Other motor vehicle	0
					South	Turning left	Automobile, station wagon	Other motor vehicle	
2016-Jul-22, Fri,20:56	Rain	SMV other	P.D. only	Wet	West	Slowing or stopping	Automobile, station wagon	Skidding/sliding	0
2016-Jul-29, Fri,03:27	Fog, mist, smoke, dust	Rear end	P.D. only	Dry	West	Going ahead	Unknown	Other motor vehicle	0
					West	Slowing or stopping	Pick-up truck	Other motor vehicle	
2016-Dec-11, Sun,09:30	Clear	SMV other	P.D. only	Ice	West	Slowing or stopping	Automobile, station wagon	Ditch	0



Transportation Services - Traffic Services

Collision Details Report - Public Version

From: January 1, 2016 To: December 31, 2020

Location: BORRISOKANE RD @ CAMBRIAN RD

Traffic Control: Stop sign

Total Collisions: 12

Date/Day/Time	Environment	Impact Type	Classification	Surface Cond'n	Veh. Dir	Vehicle Manoeuvre	Vehicle type	First Event	No. Ped
2017-Aug-29, Tue,13:57	Clear	Rear end	P.D. only	Dry	West	Turning right	Automobile, station wagon	Other motor vehicle	0
					West	Turning right	Pick-up truck	Other motor vehicle	
2017-Dec-17, Sun,08:33	Clear	SMV other	P.D. only	Dry	North	Turning right	Automobile, station wagon	Ditch	0
2018-Jun-26, Tue,11:51	Clear	SMV other	Non-fatal injury	Loose sand or gravel	West	Turning left	Motorcycle	Skidding/sliding	0
2020-Jan-07, Tue,22:24	Snow	Rear end	Non-fatal injury	Wet	South	Turning left	Pick-up truck	Other motor vehicle	0
					South	Turning left	Pick-up truck	Other motor vehicle	
2020-Jan-10, Fri,17:16	Rain	Angle	Non-fatal injury	Wet	North	Going ahead	Automobile, station wagon	Other motor vehicle	0
					West	Turning left	Automobile, station wagon	Other motor vehicle	
2020-Feb-01, Sat,13:49	Clear	Rear end	Non-fatal injury	Wet	South	Slowing or stopping	Automobile, station wagon	Other motor vehicle	0
					South	Going ahead	Automobile, station wagon	Other motor vehicle	
2020-Oct-14, Wed,18:25	Clear	Rear end	P.D. only	Dry	West	Going ahead	Pick-up truck	Other motor vehicle	0
					West	Stopped	Automobile, station wagon	Other motor vehicle	
2020-Dec-24, Thu,12:45	Clear	Turning movement	P.D. only	Wet	South	Turning left	Automobile, station wagon	Other motor vehicle	0
					North	Going ahead	Pick-up truck	Other motor vehicle	

Location: BRONSON AVE @ CATHERINE ST/RAYMOND ST

Traffic Control: Traffic signal

Total Collisions: 75

Date/Day/Time	Environment	Impact Type	Classification	Surface Cond'n	Veh. Dir	Vehicle Manoeuvre	Vehicle type	First Event	No. Ped
2016-Jan-06, Wed,14:40	Clear	Sideswipe	P.D. only	Wet	North	Changing lanes	Automobile, station wagon	Other motor vehicle	0
					North	Going ahead	Truck - dump	Other motor vehicle	
2016-Jan-19, Tue,19:28	Snow	Sideswipe	P.D. only	Slush	North	Changing lanes	Automobile, station wagon	Other motor vehicle	0
					North	Going ahead	Automobile, station wagon	Other motor vehicle	
2016-Feb-16, Tue,15:24	Snow	Angle	P.D. only	Loose snow	South	Slowing or stopping	Pick-up truck	Skidding/sliding	0
					East	Turning left	Automobile, station wagon	Other motor vehicle	

Appendix E

Cambrian Road at Apolune Street/Elevation Road Functional Design

No.	Description	Date	By	Appr.																		
3.	REVISED PER COMMENTS	J.R.	J.R.	19.04.03																		
2.	REVISED PER COMMENTS	J.R.	J.R.	18.12.18																		
1.	ISSUED FOR CLIENT REVIEW	J.R.	J.R.	18.12.18																		
Issued																						
Permit-Seal																						
<table border="1"> <thead> <tr> <th>No.</th> <th>Name</th> <th>Scale</th> <th>J.R.</th> <th>J.R.</th> <th>18.11.18</th> </tr> <tr> <th colspan="2"></th> <th>Dwn.</th> <th>Chkd.</th> <th>Dgln.</th> <th>Y.Y.A.M.00</th> </tr> </thead> <tbody> <tr> <td colspan="6">Permit-Seal</td> </tr> </tbody> </table>					No.	Name	Scale	J.R.	J.R.	18.11.18			Dwn.	Chkd.	Dgln.	Y.Y.A.M.00	Permit-Seal					
No.	Name	Scale	J.R.	J.R.	18.11.18																	
		Dwn.	Chkd.	Dgln.	Y.Y.A.M.00																	
Permit-Seal																						

Client/Project
 MATTAMY HALF MOON BAY WEST
 TAMARACK MEADOWS PHASE 5 AND 6
 Ottawa, Ontario

Title
 ROADWAY MODIFICATIONS
 CAMBRIAN RD. AT APOLINE ST./DELPHINUS AVE.
 FUNCTIONAL DESIGN PLAN

Project No. 1-636-01240 Scale 1:200
 Drawing No. Sheet Revision

01 1 of 1 1

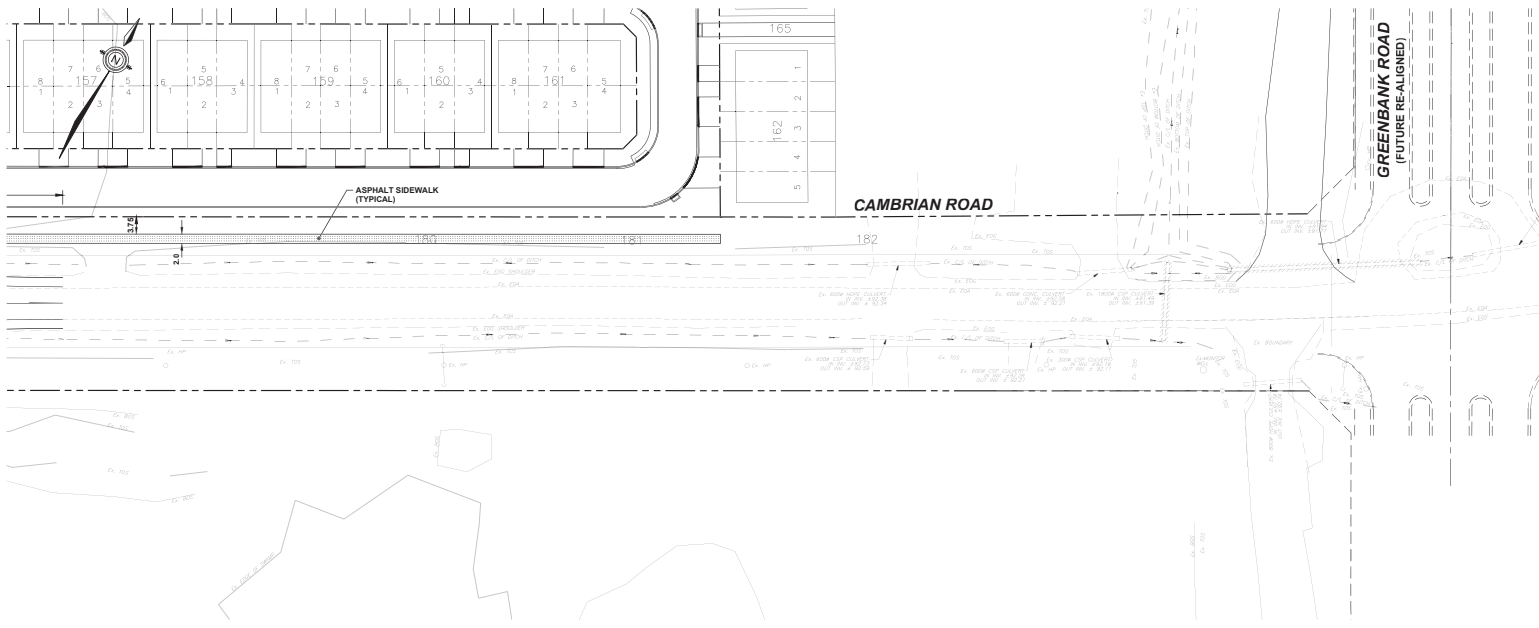
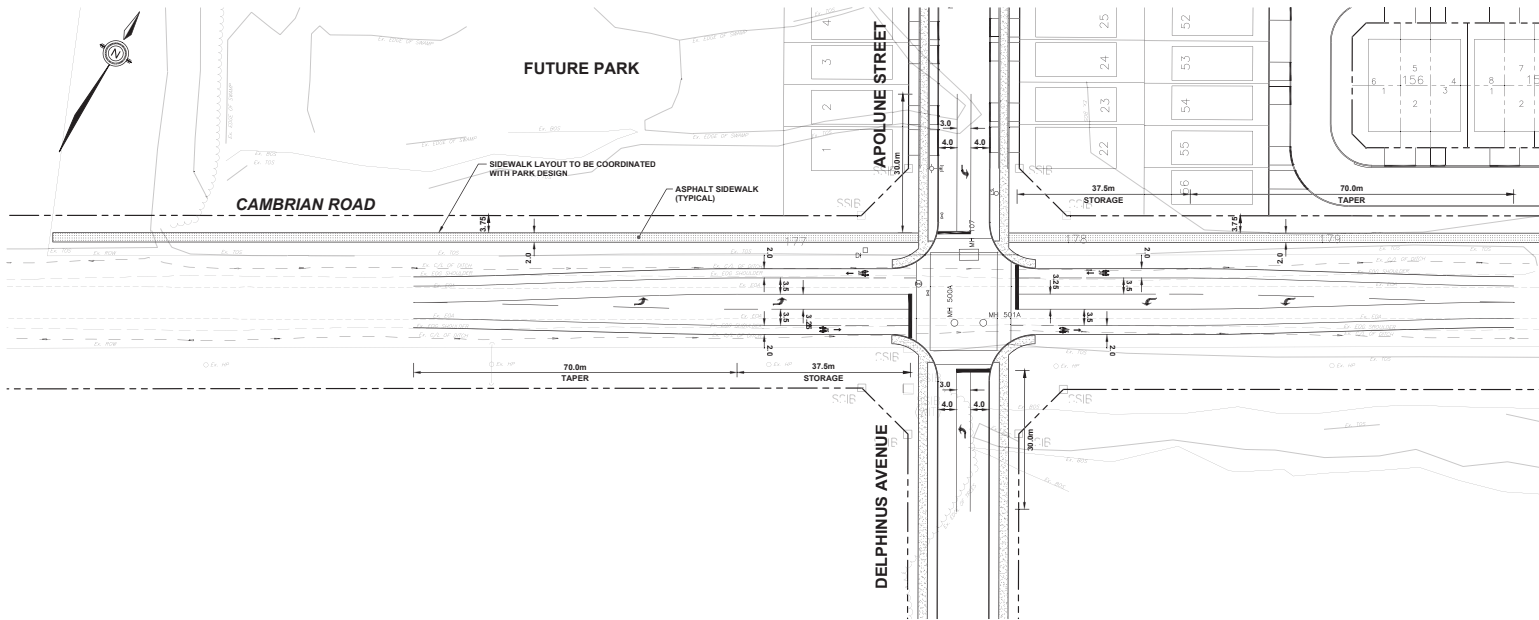

Appendix F

Borrisokane Road at Flagstaff Drive Functional Design

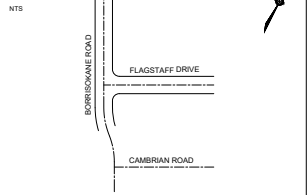

REFER TO ATTACHMENT 3

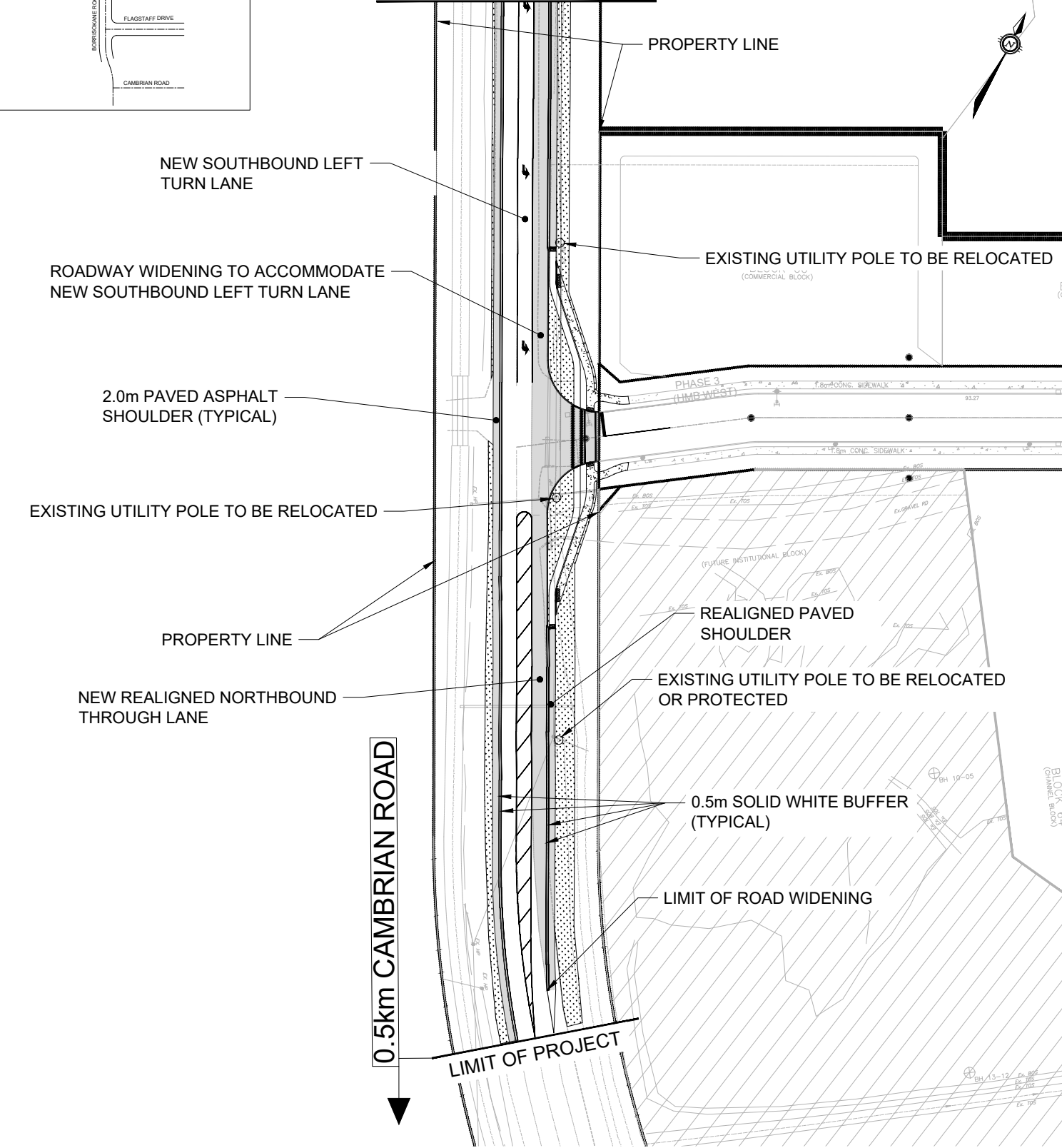

Ottawa
TRANSPORTATION
PLANNING DEPT.

MATTAMY
3345 BORRISOKANE RD

**BORRISOKANE ROAD
MODIFICATIONS**

Transportation Engineering Services

Approved By: N/A	Drawing No.: RMA-2022 -TES-###B
Completed By: CGH	
Scale: N.T.S.	Date: FEB 2023

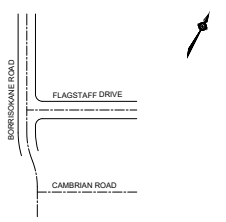

1.4km STRANDHERD DRIVE

LIMIT OF PROJECT

PROPERTY LINE

EXISTING UTILITY POLE TO BE RELOCATED OR PROTECTED

2.0m PAVED SHOULDER

ROADWAY WIDENING TO ACCOMMODATE NEW SOUTHBOUND LEFT TURN LANE

0.5m SOLID WHITE BUFFER (TYPICAL)

BLK. 99 (STREET WIDENING)

EXISTING UTILITY POLES TO BE RELOCATED OR PROTECTED

PROPERTY LINE

NEW REALIGNED NORTHBOUND THROUGH LANE

REFER TO ATTACHMENT 2



TRANSPORTATION
PLANNING DEPT.

MATTAMY
3345 BORRISOKANE RD

BORRISOKANE ROAD
MODIFICATIONS

Transportation Engineering Services

Approved By:
N/A

Drawing No.:

Completed By:
CGH

RMA-2022
-TES-###B

Scale:
N.T.S.

Date:
FEB
2023

Appendix G

Trip Generation Comparison

Updated Concept Trip Generation

Table 1: Trip Generation by Mode

Travel Mode		AM Peak Hour			PM Peak Hour		
		In	Out	Total	In	Out	Total
Strip Retail Plaza	Auto Driver	12	8	20	23	23	45
	Auto Passenger	2	2	4	10	10	20
	Transit	0	0	0	0	0	1
	Cycling	0	0	0	0	0	0
	Walking	2	1	3	4	4	8
	Pass-by	-11	-7	-18	-25	-25	-50
	Total	16	11	27	37	37	74

Previous TIA Trip Generation

Table 2: Total Trip Generation by Mode

Travel Mode		AM Peak Hour			PM Peak Hour		
		In	Out	Total	In	Out	Total
General Office Building	Auto Driver	22	4	26	4	22	26
	Auto Passenger	3	1	3	1	3	3
	Transit	1	0	2	0	1	2
	Cycling	0	0	0	0	0	0
	Walking	1	0	1	0	1	1
	Total	28	5	33	5	27	32
Shopping Center	Auto Driver	2	1	4	6	7	13
	Auto Passenger	0	0	1	3	3	6
	Transit	0	0	0	0	0	0
	Cycling	0	0	0	0	0	0
	Walking	0	0	1	1	1	2
	Pass-by	-2	-1	-3	-6	-6	-12
	Total	5	3	8	10	12	22
Total	Auto Driver	24	5	30	10	29	39
	Auto Passenger	3	1	4	4	6	9
	Transit	1	0	2	0	1	2
	Cycling	0	0	0	0	0	0
	Walking	1	0	2	1	2	3
	Pass-by	-2	-1	-3	-6	-6	-12
	Total	33	8	41	15	39	54

Appendix H

TDM Checklist

TDM Measures Checklist:
Non-Residential Developments (office, institutional, retail or industrial)

Legend	
BASIC	The measure is generally feasible and effective, and in most cases would benefit the development and its users
BETTER	The measure could maximize support for users of sustainable modes, and optimize development performance
★	The measure is one of the most dependably effective tools to encourage the use of sustainable modes

TDM measures: <i>Non-residential developments</i>		Check if proposed & add descriptions
1. TDM PROGRAM MANAGEMENT		
1.1 Program coordinator		
BASIC	★	1.1.1 Designate an internal coordinator, or contract with an external coordinator <input type="checkbox"/>
1.2 Travel surveys		
BETTER		1.2.1 Conduct periodic surveys to identify travel-related behaviours, attitudes, challenges and solutions, and to track progress <input type="checkbox"/>
2. WALKING AND CYCLING		
2.1 Information on walking/cycling routes & destinations		
BASIC		2.1.1 Display local area maps with walking/cycling access routes and key destinations at major entrances <input checked="" type="checkbox"/>
2.2 Bicycle skills training		
<i>Commuter travel</i>		
BETTER	★	2.2.1 Offer on-site cycling courses for commuters, or subsidize off-site courses <input type="checkbox"/>
2.3 Valet bike parking		
<i>Visitor travel</i>		
BETTER		2.3.1 Offer secure valet bike parking during public events when demand exceeds fixed supply (e.g. for festivals, concerts, games) <input type="checkbox"/>

TDM measures: <i>Non-residential developments</i>		Check if proposed & add descriptions
3. TRANSIT		
3.1 Transit information		
BASIC	3.1.1 Display relevant transit schedules and route maps at entrances	<input type="checkbox"/>
BASIC	3.1.2 Provide online links to OC Transpo and STO information	<input type="checkbox"/>
BETTER	3.1.3 Provide real-time arrival information display at entrances	<input type="checkbox"/>
3.2 Transit fare incentives		
<i>Commuter travel</i>		
BETTER	3.2.1 Offer preloaded PRESTO cards to encourage commuters to use transit	<input type="checkbox"/>
BETTER ★	3.2.2 Subsidize or reimburse monthly transit pass purchases by employees	<input type="checkbox"/>
<i>Visitor travel</i>		
BETTER	3.2.3 Arrange inclusion of same-day transit fare in price of tickets (e.g. for festivals, concerts, games)	<input type="checkbox"/>
3.3 Enhanced public transit service		
<i>Commuter travel</i>		
BETTER	3.3.1 Contract with OC Transpo to provide enhanced transit services (e.g. for shift changes, weekends)	<input type="checkbox"/>
<i>Visitor travel</i>		
BETTER	3.3.2 Contract with OC Transpo to provide enhanced transit services (e.g. for festivals, concerts, games)	<input type="checkbox"/>
3.4 Private transit service		
<i>Commuter travel</i>		
BETTER	3.4.1 Provide shuttle service when OC Transpo cannot offer sufficient quality or capacity to serve demand (e.g. for shift changes, weekends)	<input type="checkbox"/>
<i>Visitor travel</i>		
BETTER	3.4.2 Provide shuttle service when OC Transpo cannot offer sufficient quality or capacity to serve demand (e.g. for festivals, concerts, games)	<input type="checkbox"/>

TDM measures: <i>Non-residential developments</i>		Check if proposed & add descriptions
4. RIDESHARING		
4.1 Ridematching service		
<i>Commuter travel</i>		
BASIC ★	4.1.1 Provide a dedicated ridematching portal at OttawaRideMatch.com	<input type="checkbox"/>
4.2 Carpool parking price incentives		
<i>Commuter travel</i>		
BETTER	4.2.1 Provide discounts on parking costs for registered carpools	<input type="checkbox"/>
4.3 Vanpool service		
<i>Commuter travel</i>		
BETTER	4.3.1 Provide a vanpooling service for long-distance commuters	<input type="checkbox"/>
5. CARSHARING & BIKESHARING		
5.1 Bikeshare stations & memberships		
BETTER	5.1.1 Contract with provider to install on-site bikeshare station for use by commuters and visitors	<input type="checkbox"/>
<i>Commuter travel</i>		
BETTER	5.1.2 Provide employees with bikeshare memberships for local business travel	<input type="checkbox"/>
5.2 Carshare vehicles & memberships		
<i>Commuter travel</i>		
BETTER	5.2.1 Contract with provider to install on-site carshare vehicles and promote their use by tenants	<input type="checkbox"/>
BETTER	5.2.2 Provide employees with carshare memberships for local business travel	<input type="checkbox"/>
6. PARKING		
6.1 Priced parking		
<i>Commuter travel</i>		
BASIC ★	6.1.1 Charge for long-term parking (daily, weekly, monthly)	<input type="checkbox"/>
BASIC	6.1.2 Unbundle parking cost from lease rates at multi-tenant sites	<input checked="" type="checkbox"/>
<i>Visitor travel</i>		
BETTER	6.1.3 Charge for short-term parking (hourly)	<input type="checkbox"/>

TDM measures: <i>Non-residential developments</i>		Check if proposed & add descriptions
7. TDM MARKETING & COMMUNICATIONS		
7.1 Multimodal travel information		
<i>Commuter travel</i>		
BASIC ★	7.1.1 Provide a multimodal travel option information package to new/relocating employees and students	<input checked="" type="checkbox"/>
<i>Visitor travel</i>		
BETTER ★	7.1.2 Include multimodal travel option information in invitations or advertising that attract visitors or customers (e.g. for festivals, concerts, games)	<input type="checkbox"/>
7.2 Personalized trip planning		
<i>Commuter travel</i>		
BETTER ★	7.2.1 Offer personalized trip planning to new/relocating employees	<input type="checkbox"/>
7.3 Promotions		
<i>Commuter travel</i>		
BETTER	7.3.1 Deliver promotions and incentives to maintain awareness, build understanding, and encourage trial of sustainable modes	<input type="checkbox"/>
8. OTHER INCENTIVES & AMENITIES		
8.1 Emergency ride home		
<i>Commuter travel</i>		
BETTER ★	8.1.1 Provide emergency ride home service to non-driving commuters	<input type="checkbox"/>
8.2 Alternative work arrangements		
<i>Commuter travel</i>		
BASIC ★	8.2.1 Encourage flexible work hours	<input type="checkbox"/>
BETTER	8.2.2 Encourage compressed workweeks	<input type="checkbox"/>
BETTER ★	8.2.3 Encourage telework	<input type="checkbox"/>
8.3 Local business travel options		
<i>Commuter travel</i>		
BASIC ★	8.3.1 Provide local business travel options that minimize the need for employees to bring a personal car to work	<input type="checkbox"/>
8.4 Commuter incentives		
<i>Commuter travel</i>		
BETTER	8.4.1 Offer employees a taxable, mode-neutral commuting allowance	<input type="checkbox"/>
8.5 On-site amenities		
<i>Commuter travel</i>		
BETTER	8.5.1 Provide on-site amenities/services to minimize mid-day or mid-commute errands	<input type="checkbox"/>

TDM-Supportive Development Design and Infrastructure Checklist:
Non-Residential Developments (office, institutional, retail or industrial)

Legend	
REQUIRED	The Official Plan or Zoning By-law provides related guidance that must be followed
BASIC	The measure is generally feasible and effective, and in most cases would benefit the development and its users
BETTER	The measure could maximize support for users of sustainable modes, and optimize development performance

TDM-supportive design & infrastructure measures: <i>Non-residential developments</i>		Check if completed & add descriptions, explanations or plan/drawing references
1. WALKING & CYCLING: ROUTES		
1.1 Building location & access points		
BASIC	1.1.1 Locate building close to the street, and do not locate parking areas between the street and building entrances	<input checked="" type="checkbox"/>
BASIC	1.1.2 Locate building entrances in order to minimize walking distances to sidewalks and transit stops/stations	<input checked="" type="checkbox"/>
BASIC	1.1.3 Locate building doors and windows to ensure visibility of pedestrians from the building, for their security and comfort	<input checked="" type="checkbox"/>
1.2 Facilities for walking & cycling		
REQUIRED	1.2.1 Provide convenient, direct access to stations or major stops along rapid transit routes within 600 metres; minimize walking distances from buildings to rapid transit; provide pedestrian-friendly, weather-protected (where possible) environment between rapid transit accesses and building entrances; ensure quality linkages from sidewalks through building entrances to integrated stops/stations <i>(see Official Plan policy 4.3.3)</i>	<input type="checkbox"/>
REQUIRED	1.2.2 Provide safe, direct and attractive pedestrian access from public sidewalks to building entrances through such measures as: reducing distances between public sidewalks and major building entrances; providing walkways from public streets to major building entrances; within a site, providing walkways along the front of adjoining buildings, between adjacent buildings, and connecting areas where people may congregate, such as courtyards and transit stops; and providing weather protection through canopies, colonnades, and other design elements wherever possible <i>(see Official Plan policy 4.3.12)</i>	<input checked="" type="checkbox"/>

TDM-supportive design & infrastructure measures: <i>Non-residential developments</i>		Check if completed & add descriptions, explanations or plan/drawing references
REQUIRED	1.2.3 Provide sidewalks of smooth, well-drained walking surfaces of contrasting materials or treatments to differentiate pedestrian areas from vehicle areas, and provide marked pedestrian crosswalks at intersection sidewalks (<i>see Official Plan policy 4.3.10</i>)	<input checked="" type="checkbox"/>
REQUIRED	1.2.4 Make sidewalks and open space areas easily accessible through features such as gradual grade transition, depressed curbs at street corners and convenient access to extra-wide parking spaces and ramps (<i>see Official Plan policy 4.3.10</i>)	<input checked="" type="checkbox"/>
REQUIRED	1.2.5 Include adequately spaced inter-block/street cycling and pedestrian connections to facilitate travel by active transportation. Provide links to the existing or planned network of public sidewalks, multi-use pathways and on-road cycle routes. Where public sidewalks and multi-use pathways intersect with roads, consider providing traffic control devices to give priority to cyclists and pedestrians (<i>see Official Plan policy 4.3.11</i>)	<input checked="" type="checkbox"/>
BASIC	1.2.6 Provide safe, direct and attractive walking routes from building entrances to nearby transit stops	<input type="checkbox"/>
BASIC	1.2.7 Ensure that walking routes to transit stops are secure, visible, lighted, shaded and wind-protected wherever possible	<input type="checkbox"/>
BASIC	1.2.8 Design roads used for access or circulation by cyclists using a target operating speed of no more than 30 km/h, or provide a separated cycling facility	<input type="checkbox"/>
1.3 Amenities for walking & cycling		
BASIC	1.3.1 Provide lighting, landscaping and benches along walking and cycling routes between building entrances and streets, sidewalks and trails	<input checked="" type="checkbox"/>
BASIC	1.3.2 Provide wayfinding signage for site access (where required, e.g. when multiple buildings or entrances exist) and egress (where warranted, such as when directions to reach transit stops/stations, trails or other common destinations are not obvious)	<input type="checkbox"/>

TDM-supportive design & infrastructure measures: <i>Non-residential developments</i>		Check if completed & add descriptions, explanations or plan/drawing references
2. WALKING & CYCLING: END-OF-TRIP FACILITIES		
2.1 Bicycle parking		
REQUIRED	2.1.1 Provide bicycle parking in highly visible and lighted areas, sheltered from the weather wherever possible (see <i>Official Plan policy 4.3.6</i>)	<input checked="" type="checkbox"/>
REQUIRED	2.1.2 Provide the number of bicycle parking spaces specified for various land uses in different parts of Ottawa; provide convenient access to main entrances or well-used areas (see <i>Zoning By-law Section 111</i>)	<input checked="" type="checkbox"/>
REQUIRED	2.1.3 Ensure that bicycle parking spaces and access aisles meet minimum dimensions; that no more than 50% of spaces are vertical spaces; and that parking racks are securely anchored (see <i>Zoning By-law Section 111</i>)	<input type="checkbox"/>
BASIC	2.1.4 Provide bicycle parking spaces equivalent to the expected number of commuter cyclists (assuming the cycling mode share target is met), plus the expected peak number of customer/visitor cyclists	<input type="checkbox"/>
BETTER	2.1.5 Provide bicycle parking spaces equivalent to the expected number of commuter and customer/visitor cyclists, plus an additional buffer (e.g. 25 percent extra) to encourage other cyclists and ensure adequate capacity in peak cycling season	<input type="checkbox"/>
2.2 Secure bicycle parking		
REQUIRED	2.2.1 Where more than 50 bicycle parking spaces are provided for a single office building, locate at least 25% of spaces within a building/structure, a secure area (e.g. supervised parking lot or enclosure) or bicycle lockers (see <i>Zoning By-law Section 111</i>)	<input type="checkbox"/>
BETTER	2.2.2 Provide secure bicycle parking spaces equivalent to the expected number of commuter cyclists (assuming the cycling mode share target is met)	<input type="checkbox"/>
2.3 Shower & change facilities		
BASIC	2.3.1 Provide shower and change facilities for the use of active commuters	<input type="checkbox"/>
BETTER	2.3.2 In addition to shower and change facilities, provide dedicated lockers, grooming stations, drying racks and laundry facilities for the use of active commuters	<input type="checkbox"/>
2.4 Bicycle repair station		
BETTER	2.4.1 Provide a permanent bike repair station, with commonly used tools and an air pump, adjacent to the main bicycle parking area (or secure bicycle parking area, if provided)	<input checked="" type="checkbox"/>

TDM-supportive design & infrastructure measures: <i>Non-residential developments</i>		Check if completed & add descriptions, explanations or plan/drawing references
3. TRANSIT		
3.1 Customer amenities		
BASIC	3.1.1 Provide shelters, lighting and benches at any on-site transit stops	<input type="checkbox"/>
BASIC	3.1.2 Where the site abuts an off-site transit stop and insufficient space exists for a transit shelter in the public right-of-way, protect land for a shelter and/or install a shelter	<input type="checkbox"/>
BETTER	3.1.3 Provide a secure and comfortable interior waiting area by integrating any on-site transit stops into the building	<input type="checkbox"/>
4. RIDESHARING		
4.1 Pick-up & drop-off facilities		
BASIC	4.1.1 Provide a designated area for carpool drivers (plus taxis and ride-hailing services) to drop off or pick up passengers without using fire lanes or other no-stopping zones	<input type="checkbox"/>
4.2 Carpool parking		
BASIC	4.2.1 Provide signed parking spaces for carpools in a priority location close to a major building entrance, sufficient in number to accommodate the mode share target for carpools	<input type="checkbox"/>
BETTER	4.2.2 At large developments, provide spaces for carpools in a separate, access-controlled parking area to simplify enforcement	<input type="checkbox"/>
5. CARSHARING & BIKESHARING		
5.1 Carshare parking spaces		
BETTER	5.1.1 Provide carshare parking spaces in permitted non-residential zones, occupying either required or provided parking spaces (<i>see Zoning By-law Section 94</i>)	<input type="checkbox"/>
5.2 Bikeshare station location		
BETTER	5.2.1 Provide a designated bikeshare station area near a major building entrance, preferably lighted and sheltered with a direct walkway connection	<input type="checkbox"/>

TDM-supportive design & infrastructure measures: <i>Non-residential developments</i>		Check if completed & add descriptions, explanations or plan/drawing references
6. PARKING		
6.1 Number of parking spaces		
REQUIRED	6.1.1 Do not provide more parking than permitted by zoning, nor less than required by zoning, unless a variance is being applied for	<input checked="" type="checkbox"/>
BASIC	6.1.2 Provide parking for long-term and short-term users that is consistent with mode share targets, considering the potential for visitors to use off-site public parking	<input type="checkbox"/>
BASIC	6.1.3 Where a site features more than one use, provide shared parking and reduce the cumulative number of parking spaces accordingly (<i>see Zoning By-law Section 104</i>)	<input type="checkbox"/>
BETTER	6.1.4 Reduce the minimum number of parking spaces required by zoning by one space for each 13 square metres of gross floor area provided as shower rooms, change rooms, locker rooms and other facilities for cyclists in conjunction with bicycle parking (<i>see Zoning By-law Section 111</i>)	<input type="checkbox"/>
6.2 Separate long-term & short-term parking areas		
BETTER	6.2.1 Separate short-term and long-term parking areas using signage or physical barriers, to permit access controls and simplify enforcement (i.e. to discourage employees from parking in visitor spaces, and vice versa)	<input type="checkbox"/>
7. OTHER		
7.1 On-site amenities to minimize off-site trips		
BETTER	7.1.1 Provide on-site amenities to minimize mid-day or mid-commute errands	<input type="checkbox"/>

Appendix I

Turning Templates

A)

Garbage **Inbound**
Movement

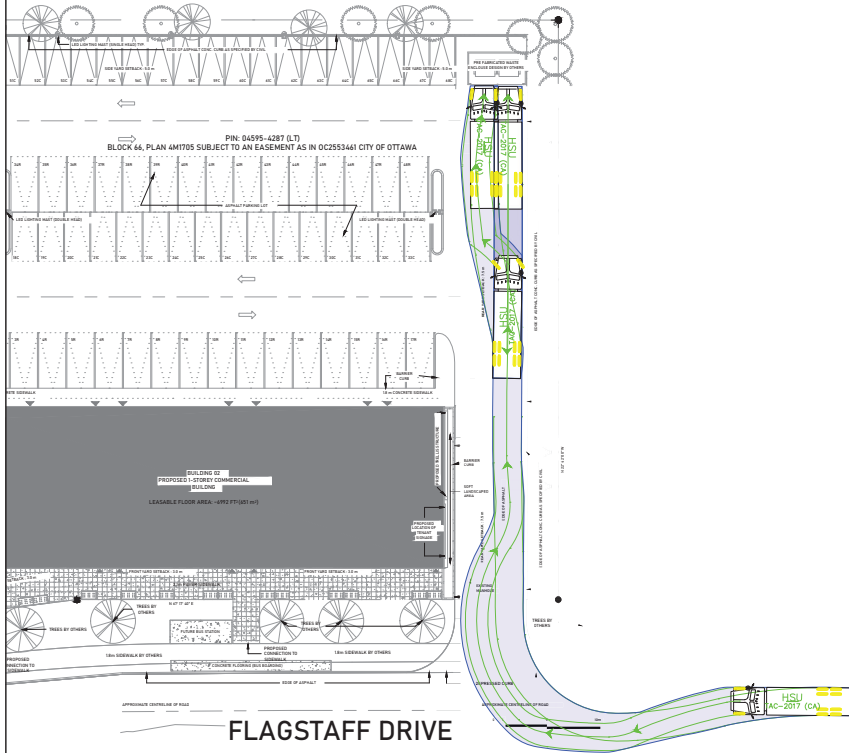

B)

Garbage **Outbound**
Movement

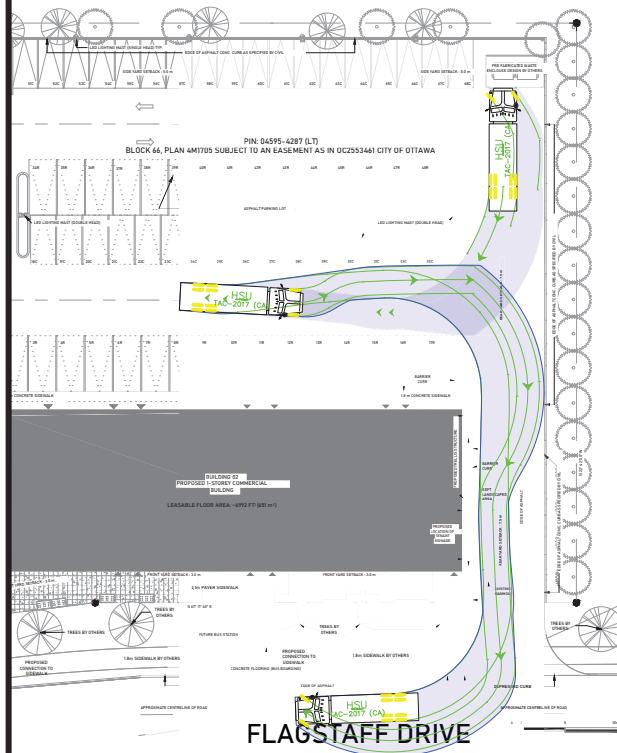

Notes:

Key Plan:

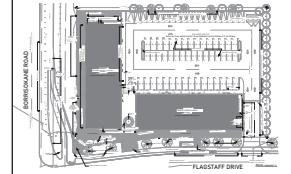

02	Issued for Review	AN	2024-01-25
REV:	DESCRIPTION:	BY:	DATE:
STATUS:			

CGH Transportation
6 Plaza Court
Ottawa, ON
K2H 7W1
(343) 999-9117

CLIENT: Nukk Properties Inc.
ARCHITECT:

SITE: 3387 Borrisokane Road

TITLE: Turning Movement Analysis
Garbage Turning Movements

SCALE AT A3:	DATE:	DRAWN:	CHECKED:
NTS	2024-01-25	AN	JK
PROJECT NO:	DRAWING NO:	REVISION:	
2022-136	001	02	