

PCL CONSTRUCTORS
REPORT NUMBER: CA0009956.0165

UNIVERSITY OF OTTAWA ADVANCED MEDICAL CENTRE STORMWATER MANAGEMENT REPORT

APRIL 18, 2024





UNIVERSITY OF
OTTAWA ADVANCED
MEDICAL CENTRE
STORMWATER
MANAGEMENT REPORT
PCL CONSTRUCTORS

1ST SUBMISSION

PROJECT NO.: CA0009956.0165
DATE: APRIL 18, 2024

WSP
SUITE 300
2611 QUEENSVIEW DRIVE
OTTAWA, ON, CANADA K2B 8K2

T: +1 613 829-2800
F: +1 613 829-8299
WSP.COM

REVISION HISTORY

FIRST ISSUE

November 30, 2023	SWM Report			
Prepared by	Prepared by	Reviewed by	Approved By	
FA	EL	IS	IS	
SECOND ISSUE				
February 26, 2024	SWM Report			
Prepared by	Reviewed by	Approved By		
FA	IS	IS		
THIRD ISSUE	SWM Report - Issued for Phase 3 Resubmission			
April 18, 2024				
Prepared by	Reviewed by	Approved By		
FA	IS	IS		

SIGNATURES

PREPARED BY

Fiona Allen

04.18.2024

Fiona Allen, P.Eng.
Project Engineer, Land Development

Date

APPROVED¹ BY



Iain Smith, P.Eng.
Senior Project Engineer, Land Development

Date

WSP Canada Inc. ("WSP") prepared this report solely for the use of the intended recipient, PCL CONSTRUCTORS, in accordance with the professional services agreement. The intended recipient is solely responsible for the disclosure of any information contained in this report. The content and opinions contained in the present report are based on the observations and/or information available to WSP at the time of preparation. If a third party makes use of, relies on, or makes decisions in accordance with this report, said third party is solely responsible for such use, reliance or decisions. WSP does not accept responsibility for damages, if any, suffered by any third party as a result of decisions made or actions taken by said third party based on this report. This limitations statement is considered an integral part of this report.

The original of this digital file will be conserved by WSP for a period of not less than 10 years. As the digital file transmitted to the intended recipient is no longer under the control of WSP, its integrity cannot be assured. As such, WSP does not guarantee any modifications made to this digital file subsequent to its transmission to the intended recipient.

¹ Approval of this document is an administrative function indicating readiness for release and does not impart legal liability on to the Approver for any technical content contained herein. Technical accuracy and fit-for-purpose of this content is obtained through the review process. The Approver shall ensure the applicable review process has occurred prior to signing the document.



TABLE OF CONTENTS

1	INTRODUCTION	1
1.1	Scope	1
1.2	Site Location	1
1.3	Stormwater Management Plan Objectives.....	1
1.4	Design Criteria	1
2	PRE-DEVELOPMENT CONDITIONS	3
2.1	General	3
2.2	Allowable Flow Rates.....	3
3	POST-DEVELOPMENT CONDITIONS	5
3.1	General	5
3.2	Water Quantity	9
3.2.1	Uncontrolled Drainage Areas	13
3.3	Water Quality	13
4	CONCLUSIONS	15

TABLES

TABLE 2-1: EXISTING CONDITIONS PEAK FLOW RATE	3
TABLE 3-1: AREA BREAKDOWN	6
TABLE 3-2: PCSWMM ATTRIBUTES	7
TABLE 3-3: FLOW CONTROL – HYDROVEX PARAMETERS	9
TABLE 3-4: DRY POND DETAILS.....	9
TABLE 3-5: SUMMARY OF PCSWMM MODELLING RESULTS – STORAGE.....	10
TABLE 3-6: SUMMARY PCSWMM MODELLING RESULTS –PONDING DEPTHS.....	11
TABLE 3-7: SUMMARY PCSWMM MODELLING RESULTS –DRY POND	11
TABLE 3-8: SUMMARY PCSWMM MODELLING RESULTS –PEAK FLOWS AND STORAGE TO OUTLET OF11.....	11
TABLE 3-9: SUMMARY PCSWMM MODELLING RESULTS –PEAK FLOWS AND STORAGE TO OUTLET 2	12
TABLE 3-9: SUMMARY OF PCSWMM MODELLING RESULTS – PEAK FLOWS FROM SITE	13
TABLE 3-6: UNCONTROLLED DRAINAGE AREAS....	13
TABLE 3-6: TOTAL TSS REMOVAL	14

FIGURES

FIGURE 1. SITE LOCATION	2
FIGURE 2: EXISTING CONDITION.....	4
FIGURE 3: PROPOSED CONDITION	8

APPENDICES

A	PRE-CONSULTATION MEETING MINUTES AND TECHNICAL COMMENTS
B	TECHNICAL DOCUMENTS
B-1	Stormwater Management Calculations
B-2	PCSWMM Output
C	SUPPORTING DOCUMENTS

1 INTRODUCTION

1.1 SCOPE

WSP Canada Inc. was retained by PCL Constructors to prepare a Stormwater Management (SWM) report for the proposed development at 451 Smyth Road Ottawa, Ontario. This SWM report examines the potential water quality and quantity impacts of the advanced medical research facility and summarizes how each will be addressed in accordance with applicable guidelines.

1.2 SITE LOCATION

The site of the proposed development is located at the Northwest corner of 451 Smyth Road, Ottawa, Ontario. The subject site is an existing parking lot servicing Roger Guidon Hall.

1.3 STORMWATER MANAGEMENT PLAN OBJECTIVES

The objectives of the stormwater management plan are as follows:

- Collect and review background information
 - Determine the site-specific stormwater management requirements to ensure that the proposals are in conformance with the applicable Provincial, Municipal and Conservation Authority stormwater management and development guidelines.
 - Evaluate various stormwater management practices that meet the applicable SWM and development requirements and recommend a preferred strategy.
 - Prepare a stormwater management report documenting the strategy along with the technical information necessary for the justification and sizing of the proposed stormwater management facilities.
-

1.4 DESIGN CRITERIA

Design criteria were obtained through the Site Plan Pre-Application Consultation Notes provided by the City of Ottawa on August 23rd, 2023 (pre consultation notes in **Appendix A**). Criteria for 451 Smyth Road are as follows:

- **Stormwater Quantity**
 - Control post-development flows up to the 100-year return period to the 2-year pre-development level with a runoff coefficient (C) of 0.5. The existing drainage patterns for the site should be maintained
 - Ensure no overland flow for all storms up to and including the 100-year event. Provide adequate emergency overflow conveyance off-site.
- **Stormwater Quality**
 - The City has requested that 80% TSS removal at be provided. Correspondence is included in **Appendix A**.

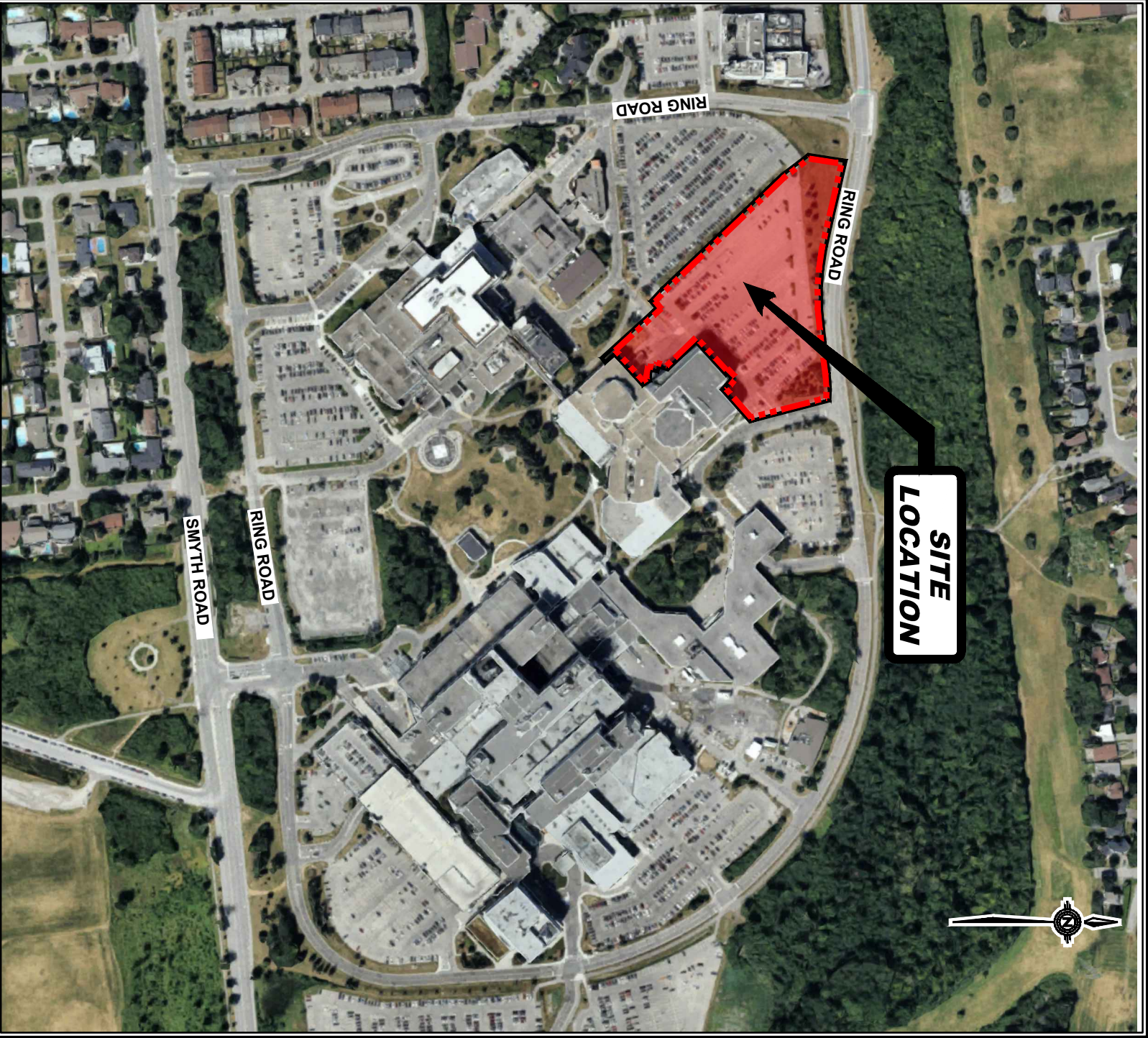

@2023 Google - Map Canada

CLIENT

PCL CONSTRUCTORS

TITLE

UNIVERSITY OF OTTAWA
ADVANCED MEDICAL CENTRE
SITE LOCATION



100 Commerce Valley Dr. West, Thornhill, ON Canada L3T 0A1
T: 905.882.1100 F: 905.882.0055 www.uottawa.ca

Checked	I.S.	Drawn	AUTOCAD/M.ST.L.
Date	OCTOBER 2023	Proj. No.	CA0009956.0165
Scale	N.T.S.	Figure No.	1
		Gr.No.	00

2 PRE-DEVELOPMENT CONDITIONS

2.1 GENERAL

The subject site is a 2.02 ha parcel of land comprised of a parking lot. Under existing conditions, a series of catch basins located throughout the parking lot drain into the existing storm sewer network on Ring Road

2.2 ALLOWABLE FLOW RATES

Existing conditions peak flows were calculated using the Rational Method with a runoff coefficient of 0.5 and a time of concentration of 10 minutes. A runoff coefficient of 0.50 was used as per Ottawa Sewer Design Guidelines section 8.3.7.3

$$Q = 2.78CiA$$

Where:

- Q = peak flow rate (L/s)
- C = runoff coefficient
- i = rainfall intensity (mm/hour)
- A = catchment area (hectares)

The rainfall intensity is calculated in accordance with Section 5.4.2 of the Ottawa Sewer Design Guidelines (October, 2012):

Where;

$$i = \left[\frac{A}{(Td + C)^B} \right]$$

- A, B, C = regression constants for each return period (defined in section 5.4.2)
- i = rainfall intensity (mm/hour)
- Td = storm duration (minutes)

The IDF parameters/regression constants are per the Ottawa Sewer Design Guidelines (October, 2012).

This results in an allowable release rate of 215.7 L/s. The allowable release rate is outlined in Table 2-1 and detailed calculations are available in **Appendix B**.

Table 2-1: Existing Conditions Peak Flow Rate

Return Period (Year)s	Rainfall Intensity (mm/hr)	Allowable Release Rate (L/s) ¹
2	76.8	215.7

¹Under 2-year storm using an area of 2.02 ha, a runoff coefficient of 0.50 and a time of concentration of 10 minutes

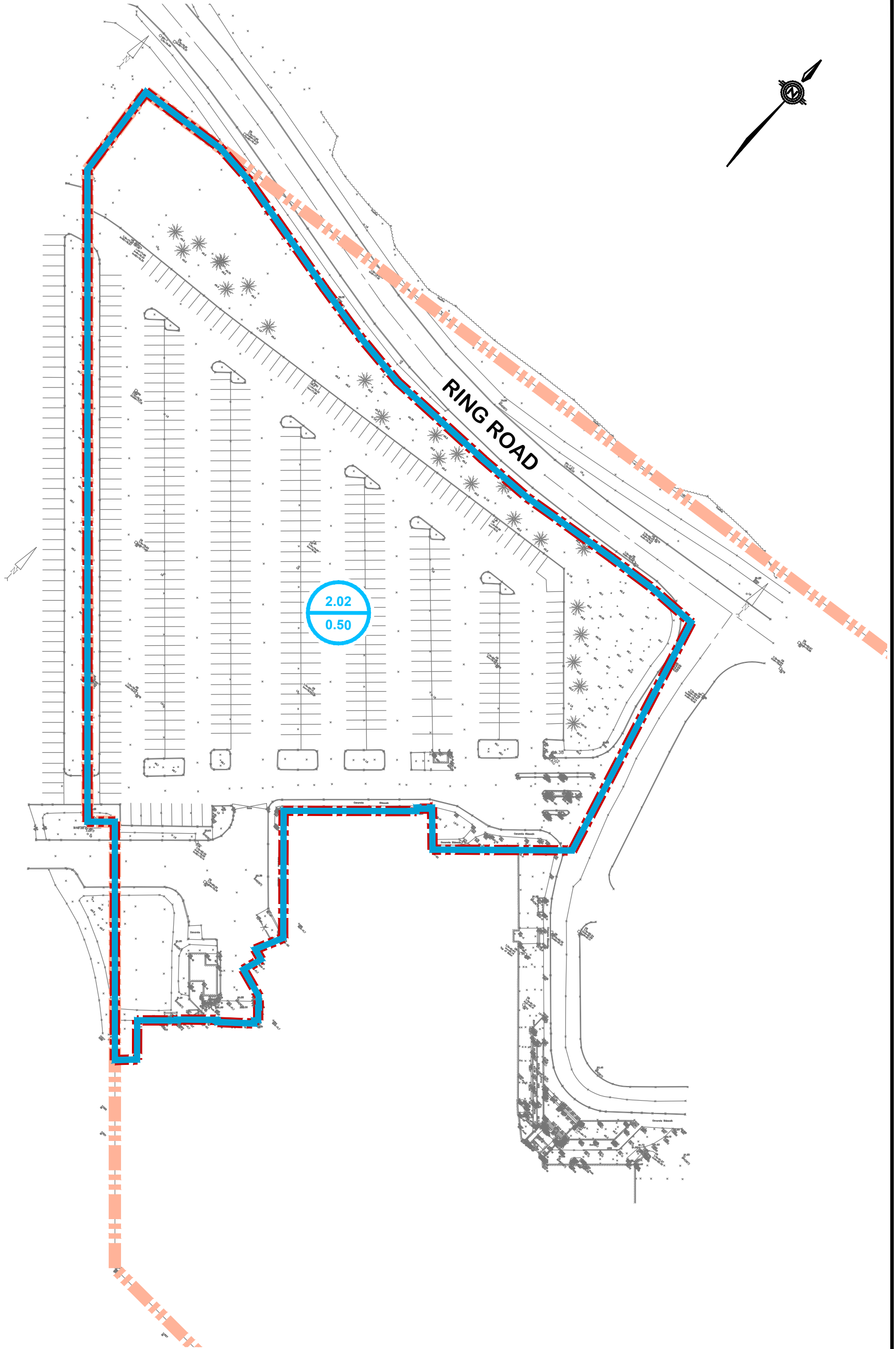
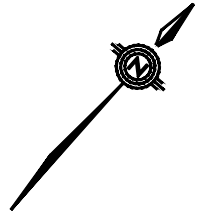

LEGEND

- PROPERTY BOUNDARY
- DEVELOPMENT BOUNDARY
- CATCHMENT BOUNDARY

- DRAINAGE AREA (ha)
- AVERAGE RUNOFF COEFFICIENT

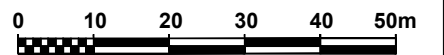

CLIENT	PCL CONSTRUCTORS
TITLE	UNIVERSITY OF OTTAWA ADVANCED MEDICAL CENTRE EXISTING CONDITIONS



100 Commerce Valley Dr. West, Thornhill, ON Canada L3T 0A1
t: 905.882.1100 f: 905.882.0055 wsp.com

Checked I.S.	Drawn AUTOCAD / M.ST.L.
Date OCTOBER 2023	Proj. No. CA0009956.0165
Scale AS SHOWN	Figure No. 2

3 POST-DEVELOPMENT CONDITIONS

3.1 GENERAL

The proposed development consists of the construction of an advanced medical research centre along with a new at-grade parking lot. Vehicular access to the site is provided via a driveway leading to Ring Road. The site is 2.02 hectares in size and all stormwater runoff will ultimately discharge to existing storm sewers. Post development condition drainage areas and runoff coefficients are shown in the Drainage Area Plan (C110) and summarized in Table 3-1.

Due to the geometry of the site, certain areas cannot be controlled by the proposed chamber system or dry pond and will be captured by the existing storm network including the northern edge and parts of the eastern edge of the site. The site will drain to the existing storm sewer within Ring Road which drains to the Rideau River. The controlled areas of the site (including the proposed parking lot and building roof, the loading dock area) will drain through a series of catch basins into a proposed storm sewer network which will also connect to the existing storm sewer network on Ring Road. Approximately 0.22 ha (10.6%) of the site will be uncontrolled while 1.80 ha (89.3%) of the site will be controlled.

An estimated area breakdown for the new layout is provided in Table 3-1.

Table 3-1: Area Breakdown

Catchment ID	Area (ha)	% Coverage of Project Area	Pervious Area (ha)	Impervious Area (ha)	% Imperv.	Runoff Coefficient	Peak 100-year Uncontrolled Runoff (m ³ /s)
Controlled Drainage Areas							
A-4	0.1485	7.37%	0.0285	0.1199	19.2	0.33	0.0128
A-6	0.1023	5.08%	0.0845	0.0178	17.4	0.32	0.0216
A-7	0.0589	2.92%	0.0054	0.0535	90.8	0.84	0.0386
A-8	0.0439	2.18%	0.0015	0.0437	96.6	0.88	0.0290
A-9	0.0335	1.66%	0.000	0.0335	100	0.90	0.0225
A-10	0.0259	1.29%	0.0029	0.0231	88.9	0.82	0.0171
A-11	0.0424	2.10%	0.0061	0.0364	85.7	0.80	0.0265
A-12	0.1039	5.16%	0.0287	0.0753	72.4	0.71	0.0561
A-13	0.0475	2.36%	0.0018	0.0457	96.1	0.87	0.0314
A-14	0.0701	3.48%	0.0153	0.0549	78.2	0.75	0.0419
A-15	0.0569	2.82%	0.0114	0.0455	79.9	0.76	0.0343
A-16	0.0646	3.20%	0.0125	0.0520	80.6	0.76	0.0384
A-17	0.1424	7.06%	0.0069	0.1354	95.1	0.87	0.0910
A-18	0.1522	7.55%	0.0116	0.1406	92.3	0.84	0.0944
A-20	0.0558	2.77%	0.0259	0.0299	53.6	0.58	0.0236
A-21	0.0749	3.72%	0.0293	0.0456	60.9	0.63	0.0372
A-22	0.0603	2.99%	0.0173	0.0430	71.3	0.70	0.0326
A-23	0.0997	4.95%	0.0109	0.0888	89.1	0.81	0.0616
R-1	0.4167	20.67%	0	0.04167	100	0.90	0.2558
Uncontrolled Drainage Areas							
A-1	0.0442	2.19%	0.0124	0.0318	71.9	0.74	0.0248
A-5	0.0312	1.55%	0.0312	0.0000	0.0	0.22	0.0039
A-19	0.0200	0.99%	0.0084	0.0116	58.0	0.61	0.0104
R-2	0.1198	5.94%	0	0.1198	100	0.90	0.0787
Total Project Area	2.02	100.0%	0.4330	1.583	78.52	0.76	

The standard City of Ottawa values were used for infiltration, depression storage, and roughness coefficient values as described in Table 3-2.

Table 3-2: PCSWMM Attributes

PCSWMM Parameter	Value
N Imperv	0.013
N Perv	0.25
Dstore Imperv (mm)	1.57
Dstore Perv (mm)	4.67
Max. Infil. Rate (mm/hr)	76.2
Min. Infil. Rate (mm/hr)	13.2
Decay Constant (1/hr)	4.14
Drying Time (days)	7

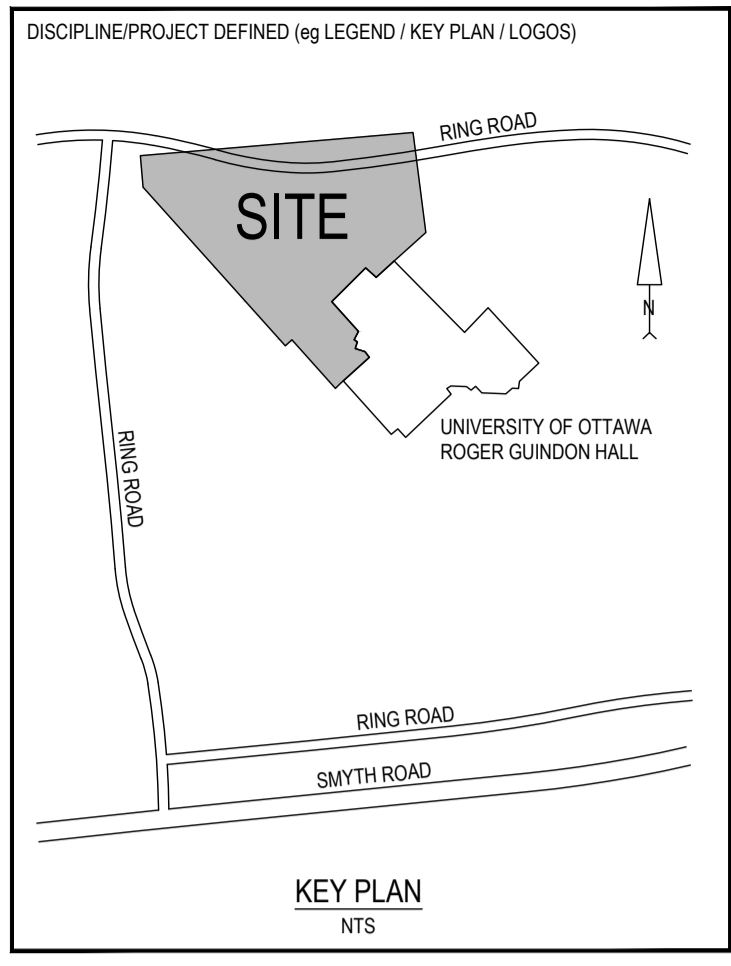
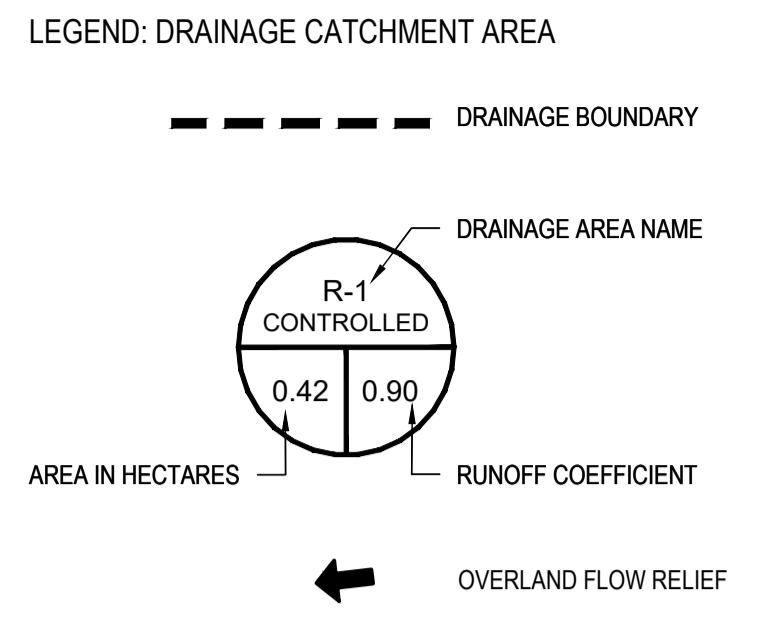
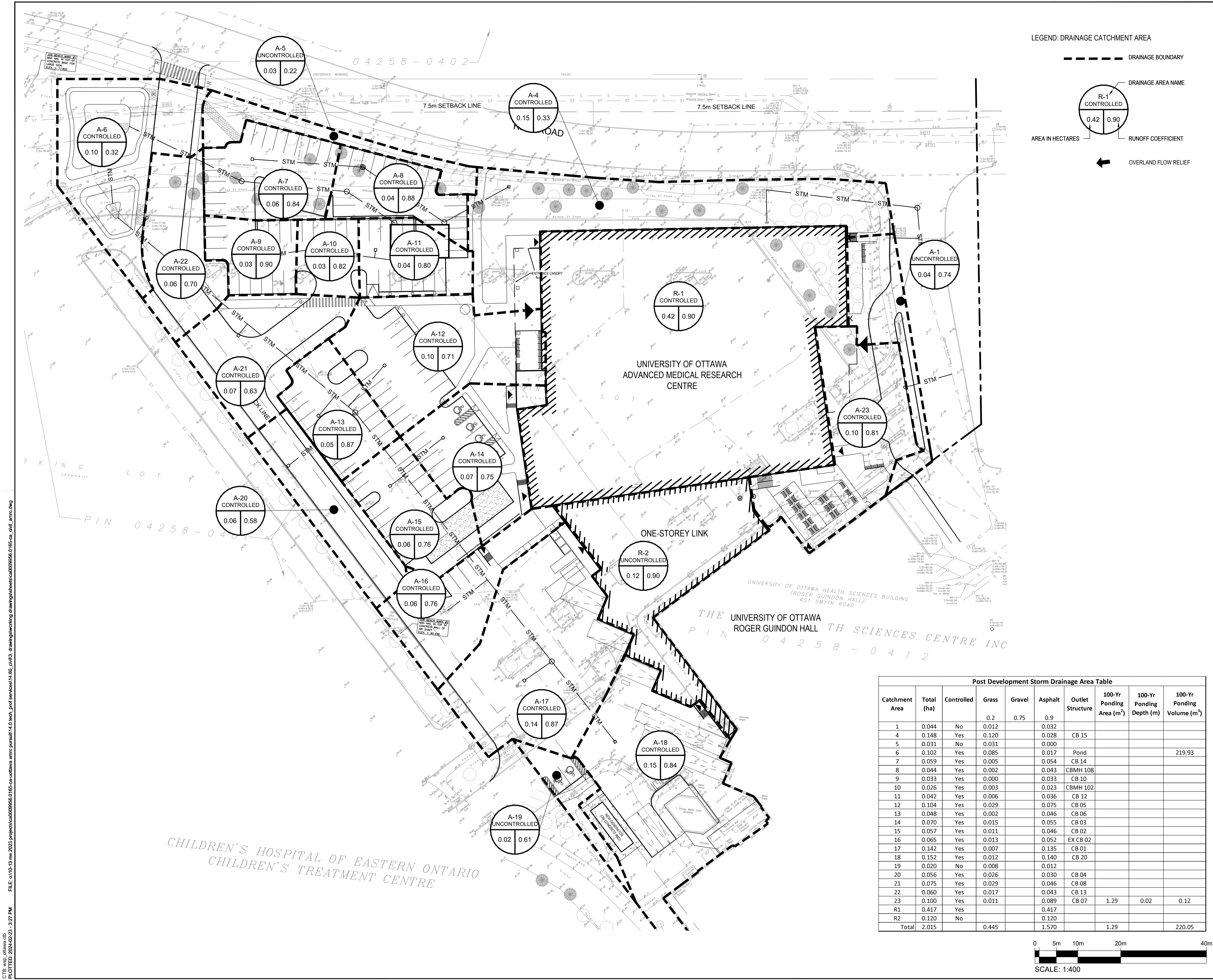

REVISION:

REV	DATE	DESCRIPTION	BY
5	2024-02-26	ISSUED FOR SITE PLAN APPROVAL	VT
4	2024-02-02	ISSUED FOR COORDINATION	VT
3	2023-11-30	ISSUED FOR SITE PLAN APPROVAL	VT
2	2023-11-20	ISSUED FOR BUILDING PERMIT	VT
1	2023-10-31	ISSUED FOR PRICING PROPOSAL	VT

SEAL: NORTH

DISCLAIMER: THIS DRAWING AND DESIGN IS COPYRIGHT PROTECTED WHICH SHALL NOT BE USED, REPRODUCED OR REVISED WITHOUT WRITTEN PERMISSION BY WSP. THE CONTRACTOR SHALL CHECK AND VERIFY ALL DIMENSIONS AND UTILITY LOCATIONS AND REPORT ALL ERRORS AND OMISSIONS PRIOR TO COMMENCING WORK.

ORIGINAL SCALE: AS NOTED
DESIGNED BY: Y. TENG
DRAWN BY: B. NANDLAL
APPROVED BY: I. JAFFERJEE
DISCIPLINE: CIVIL

DATE: 2023-09-25
IF THIS BAR IS NOT 25mm LONG, ADJUST YOUR PLOTTING SCALE.
25mm

WSP CANADA INC.
2611 QUEENVIEW DRIVE, SUITE 300
OTTAWA ONTARIO K2B 8K2 CANADA
WSP.COM

PROJECT NUMBER: CA0009956.0165-CA

CLIENT: uOttawa

CLIENT REF. #:

PROJECT: ADVANCED MEDICAL RESEARCH CENTRE

TITLE: DRAINAGE CATCHMENT AREA PLAN

DRAWING NUMBER: C110

REV: 5

Post Development Storm Drainage Area Table

Catchment Area	Total (ha)	Controlled	Grass	Gravel	Asphalt	Outlet Structure	100-Yr Ponding Area (m ²)	100-Yr Ponding Depth (m)	100-Yr Ponding Volume (m ³)
1	0.044	No	0.012		0.032				
4	0.148	Yes	0.120		0.028	CB 15			
5	0.031	No	0.031		0.000				
6	0.102	Yes	0.085		0.017	Pond			219.93
7	0.059	Yes	0.005		0.054	CB 14			
8	0.044	Yes	0.002		0.043	CBMH 108			
9	0.033	Yes	0.000		0.033	CB 10			
10	0.026	Yes	0.003		0.023	CBMH 102			
11	0.042	Yes	0.006		0.036	CB 12			
12	0.104	Yes	0.029		0.075	CB 05			
13	0.048	Yes	0.002		0.046	CB 06			
14	0.070	Yes	0.015		0.055	CB 03			
15	0.057	Yes	0.011		0.046	CB 02			
16	0.065	Yes	0.013		0.052	EX CB 02			
17	0.142	Yes	0.007		0.135	CB 01			
18	0.152	Yes	0.012		0.140	CB 20			
19	0.020	No	0.008		0.012				
20	0.056	Yes	0.026		0.030	CB 04			
21	0.075	Yes	0.029		0.046	CB 08			
22	0.060	Yes	0.017		0.043	CB 13			
23	0.100	Yes	0.011		0.089	CB 07	1.29	0.02	0.12
R1	0.417	Yes			0.417				
R2	0.120	No			0.120				
Total	2.015		0.445		1.570		1.29		220.05

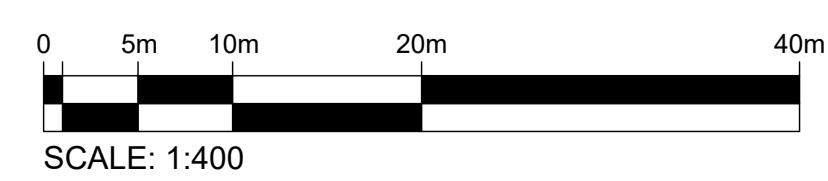

C:\Users\wsp_ottawa\OneDrive\Documents\2024-02-26_3:27 PM FILE: c:\10-13_mir-2023\project\ca0009956.0165-ca-ottawa-amrc\pursuit\4.0\back_prof\services\14.60_civil\drawing\working\drawing\sheet\ca0009956.0165-ca_dwg_amrc.dwg

3.2 WATER QUANTITY

As noted previously, it is required that the 100-year post-development discharge rate from the site not exceed 216 L/s.

Proposed features to achieve this target include;

- Surface, dry pond, pipe, and chamber storage with inlet control device (ICD) (HYDROVEX VHV or equivalent)
- Rooftop storage with controlled roof drains (WATTS Adjustable Accutrol or equivalent).

PCSWMM software was used to model the behaviour of the proposed SWM system. A schematic of the PCSWMM model is included in **Appendix B**.

Surface ponding has been proposed on the parking lot at catch basin CB7 at its low point, and within the proposed storm sewer. To determine peak surface ponding depths and volumes, reference has been made to the model output at each respective storage node where surface storage is utilized. Ponding depths have been simulated in the model by routing runoff from the contributing sub-catchment area to a storage node defined with a stage-storage relationship describing the ponding volume available on the surface (based on proposed grading). Flow into catch basin CB7 is modelled using the head-discharge relationship for an orifice plate.

Runoff from catchments A-4 and A-7 to A-11 is directed to a StormTech ADS MC-7200 chamber system which is proposed to provide 172.4 m³ of storage. The manufacturer's design sheet included in **Appendix C**. Primary flow control for the chamber is provided by a downstream Hydrovex VHV ICD, which is modelled using the supplier's head-discharge rating curve on the outlet of STMH 112. The specified Hydrovex is model shown in Table 3-3. Supporting documentation for the Hydrovex ICD is included in **Appendix C**.

Table 3-3: Flow Control – HYDROVEX Parameters

Location	ICD	Peak Head (m)	Peak Flow (m ³ /s)
STMH 112	50-VHV-1	1.923	0.0041

A two cell dry pond in the north-west corner of the of the site is to provide quantity control for catchments A-6, A-12 to A-18, and A-20 to A-22. The smaller cell, referred to as small pond throughout the report, provides 40.9 m³ of storage and the bigger cell, referred to as big pond throughout the report, provides 182.3 m³. Flows are conveyed between the cells through a 525 mm culvert which ensures that the two cells are hydraulically connected. Outflow from the pond is controlled by a 175 mm orifice plate and is modelled using the head-discharge relationship for an orifice plate. See Table 3-4 for details regarding the storage volumes of each cell. Please see the proposed Grading Plan for additional details.

Table 3-4: Dry Pond Details

Description	Elevation (m)	Small Pond Storage (m ³)	Big Pond Storage (m ³)
Bottom of Pond	76.20	0.00	0.00
Top of Pond	77.2	40.9	182.3
Top of Freeboard	77.5	72.0	268.6

Storage on the roof was defined by the available roof area. Outflow from the roof was defined using the supplier head-discharge curve for fully closed and exposed roof drains, multiplied by the number of roof drains. Runoff from roof section R1 is proposed to be controlled by a combination of 37 fully closed and exposed roof drains. Calculations provided in **Appendix B1** outlines the number of each drain type and the ponding volume associated with it. Supporting documentation for the Accutrol roof drains is included in **Appendix C**.

A summary of modeling results are provided in Table 3-5 and Table 3-6, with detailed modelling output included in **Appendix B**.

Table 3-5: Summary of PCSWMM Modelling Results – Storage

Location	Return Period					
	2-Year	5-Year	10-Year	25-Year	50-Year	100-Year
Storage Utilized at CB1 (m ³)	0.035	0.043	0.048	0.055	0.068	0.138
Storage Utilized at CB2 (m ³)	0.019	0.023	0.025	0.028	0.030	0.038
Storage Utilized at CB3 (m ³)	0.021	0.025	0.028	0.031	0.033	0.138
Storage Utilized at CB4 (m ³)	0.039	0.043	0.045	0.048	0.063	0.107
Storage Utilized at CB5 (m ³)	0.103	0.108	0.112	0.116	0.119	0.130
Storage Utilized at CB6 (m ³)	0.020	0.023	0.026	0.028	0.038	0.081
Storage Utilized at CB7 (m ³)	0.103	0.203	0.287	0.414	0.523	0.863
Storage Utilized at CB8 (m ³)	0.024	0.029	0.062	0.114	0.151	0.195
Storage Utilized at CB12 (m ³)	0.018	0.059	0.113	0.193	0.259	0.340
Storage Utilized at CB13 (m ³)	0.012	0.045	0.087	0.139	0.176	0.220
Storage Utilized at CB14 (m ³)	0.025	0.031	0.049	0.128	0.194	0.275
Storage Utilized at CB15 (m ³)	0.010	0.020	0.074	0.153	0.219	0.300
Storage Utilized at CB20 (m ³)	0.040	0.051	0.060	0.113	0.163	0.309
Storage Utilized at EXCB02 (m ³)	0.021	0.025	0.028	0.031	0.033	0.050
Storage Utilized Chamber (m ³)	38.5	57.3	72.8	94.6	111.9	131.5
Total Storage Utilized Dry Pond (m ³)	55.7	89.0	114.9	151.5	181.3	219.9
R1 Roof Storage (m ³)	233.3	285.6	318.7	354.7	380.4	406.6

Table 3-6: Summary PCSWMM Modelling Results –Ponding Depths

Location	Return Period					
	2-Year	5-Year	10-Year	25-Year	50-Year	100-Year
Ponding depth CB7 (m)	0.00	0.00	0.00	0.00	0.00	0.02
R1 Roof ponding depth (m)	0.08	0.09	0.10	0.12	0.12	0.13

The ICD was selected to ensure peak ponding remains below 0.3 m during the 100-year event, the target release rate is met, and ponding is avoided during the 2-year event. CB7 has no surface ponding for the 2 to 50-year events. The peak ponding depth on the roof is 0.13 m, which is below the maximum allowable roof ponding depth of 0.15 m.

Table 3-7: Summary PCSWMM Modelling Results –Dry Pond

Location	Return Period					
	2-Year	5-Year	10-Year	25-Year	50-Year	100-Year
Small Pond-Ponding Elevation (m)	76.53	76.70	76.82	76.97	77.07	77.19
Small Pond-Storage Utilized Storage (m ³)	5.48	11.12	16.17	24.1	31.01	40.53
Big Pond-Ponding Elevation (m)	76.53	76.70	76.82	76.97	77.07	77.19
Big Pond-Storage Utilized Storage (m ³)	50.2	77.89	98.71	127.4	150.3	179.4

Controlled and uncontrolled flow from catchments A-1, A-23, R-1, and R-2 are directed to outlet OF1. The storage provided and utilized for all storage volumes which drain to OF1 are present below in Table 3-8. Additionally, all contributing flow to OF1 is also presented in Table 3-8.

Table 3-8: Summary PCSWMM Modelling Results –Peak Flows and Storage to Outlet OF1

Location	Return Period	
	2-Year	100-Year
R-1 Storage Utilized(m ³)	233.3	406.6
R-1 Total Storage(m ³)	463.1	
CB7 Storage Utilized (m ³)	0.103	0.863
CB7 Total Storage(m ³)	8.35	
A-1 Runoff (m ³ /s)	0.007	0.025
Flow from EXSTMH02 to OF1 (m ³ /s) ¹	0.057	0.109
OF1 (m ³ /s)	0.064	0.134

¹Includes controlled flow from A-23 and R-1 and uncontrolled flow from R-2

Controlled and uncontrolled flow from catchments A-4 to 22 is directed to outlet OF2. The storage provided and utilized for all storage volumes which drain to OF2 are present below in Table 3-9. Additionally, all contributing flow to OF2 is presented in Table 3-9.

Table 3-9: Summary PCSWMM Modelling Results –Peak Flows and Storage to Outlet 2

Location	Return Period	
	2-Year	100-Year
Storage Utilized at CB1 (m ³)	0.035	0.138
Total Storage at CB1 (m ³)	1.026	
Storage Utilized at CB2 (m ³)	0.019	0.038
Total Storage at CB2 (m ³)	0.612	
Storage Utilized at CB3 (m ³)	0.021	0.138
Total Storage at CB3 (m ³)	0.720	
Storage Utilized at CB4 (m ³)	0.039	0.038
Total Storage at CB4 (m ³)	0.691	
Storage Utilized at CB5 (m ³)	0.103	0.130
Total Storage at CB5 (m ³)	0.648	
Storage Utilized at CB6 (m ³)	0.020	0.081
Total Storage at CB6 (m ³)	0.936	
Storage Utilized at CB8 (m ³)	0.024	0.195
Total Storage at CB8 (m ³)	0.595	
Storage Utilized at CB12 (m ³)	0.018	0.340
Total Storage at CB12 (m ³)	1.145	
Storage Utilized at CB13 (m ³)	0.012	0.220
Total Storage at CB13 (m ³)	0.518	
Storage Utilized at CB14 (m ³)	0.025	0.275
Total Storage at CB14 (m ³)	0.623	
Storage Utilized at CB15 (m ³)	0.010	0.300
Total Storage at CB15 (m ³)	1.080	
Storage Utilized at CB20 (m ³)	0.040	0.309
Total Storage at CB20 (m ³)	0.612	
Storage Utilized at EXCB02 (m ³)	0.021	0.050
Total Storage at EXCB02 (m ³)	0.911	
Storage Utilized Chamber (m ³)	38.5	131.5
Total Storage Chamber (m ³)	172.4	
Total Storage Utilized Dry Pond (m ³)	55.7	219.9
Total Storage Dry Pond (m ³)	223.2	
A-5 Runoff (m ³ /s)	0.0002	0.004
A-19 Runoff (m ³)	0.003	0.010
Flow from EXSTMH01 to OF2 (m ³ /s) ¹	0.055	0.079

Location	Return Period	
	2-Year	100-Year
Total Flow to OF2	0.056	0.083

¹Includes controlled flow from A-4, A-6 to A-18 and A-20 to A-22

Table 3-10: Summary of PCSWMM Modelling Results – Peak Flows from Site

Location	Return Period					
	2-Year	5-Year	10-Year	25-Year	50-Year	100-Year
Peak Discharge OF1 – to storm sewer (m ³ /s)	0.064	0.084	0.098	0.115	0.119	0.134
Peak Discharge OF2 – to storm sewer(m ³ /s)	0.056	0.064	0.069	0.075	0.079	0.083
Peak Discharge OF1+OF2 – total flow to storm sewer(m³/s)	0.115	0.144	0.163	0.185	0.194	0.208

The peak overall 100-year discharge rate is 0.208 m³/s, which is below the target release rate of 0.216 m³/s. Please note that the peak flows to each outlet occur at different times. The graphed flow to each outlet is provided in Appendix B.

3.2.1 UNCONTROLLED DRAINAGE AREAS

As shown in Section 3.1, Subcatchments A-1, A-3, and A-5 drain uncontrolled to the right-of-way (ROW), while Subcatchment A-19 drains to the adjacent existing parking lot. Table 3-11 shows a summary of the uncontrolled areas by discharge location under proposed conditions.

Table 3-11: Uncontrolled Drainage Areas

Discharge Location	Proposed			
	Catchment ID	Area (ha)	C	100-year Flows (m ³ /s)
East to Ring Rd	A-1	0.044	0.74	0.0248
North to Ring Rd	A-5	0.031	0.22	0.0039
West to Existing Parking Lot	A-19	0.020	0.61	0.0104
Total		0.095	0.54	0.03862

3.3 WATER QUALITY

As outlined in Section 1.4, it is required that post development runoff be treated to achieve 80% TSS removal. Proposed features to achieve these targets include:

- one EFO4 OGS units rated at 60% TSS removal

- one EFO6 OGS units rated at 60% TSS removal
- ADS StormTech Isolator Row rated at 80% TSS removal
- Existing Downstream Vortech OGS rated at 50% TSS removal
- Roof Runoff Clean rated at 80% TSS removal

A total TSS removal across the site was determined with the New Jersey equation and the average TSS removal across the site, displayed in Table 3-12 below. Detailed calculations can be found in Appendix B.

Table 3-12: Total TSS removal

Catchment	Area (ha)	TSS Removal (%)
A4,A7-11	0.35	96
A6, A12-18, and A20-22	0.93	80
A1, A5, A19, and A23	0.20	50
R1 and R2	0.54	80
Total	2.02	80

The sizing reports for the EFOs, existing Vortech OGS and ETV certification for the for the ADS isolator row unit area provided in **Appendix C**.

4 CONCLUSIONS

A stormwater management report has been prepared to support the proposed development at 451 Smyth Road in the City of Ottawa. The key points are summarized below.

WATER QUALITY

Two EFOs, an ADS Isolator Row, and an existing downstream OGS are proposed to provide the required Enhanced level of protection for the site by removing at least 80% of the annual TSS.

WATER QUANTITY

Runoff will be controlled by ponding surface storage on the parking lot, a two cell dry pond, underground chamber, and rooftop storage on the building. Flow from the parking area, two cell dry pond, and underground chamber will be controlled with an ICD, and roof drainage will be controlled with adjustable roof drains. Runoff from the site will be controlled to 0.208 m³/s, which is below the allowable release rate of 0.216 m³/s set for this site.

APPENDIX

A

PRE-CONSULTATION
MEETING MINUTES
AND TECHNICAL
COMMENTS

August 25, 2023

Nadia De Santi

WSP

Via email: nadia.de-santi@wsp.com

**Subject: Phase 1 - Pre-Consultation: Meeting Feedback
Proposed Site Plan and likely Zoning By-Law Amendment
Application – 451 Smyth Road and 630 Peter Morand**

Please find below information regarding next steps as well as consolidated comments from the above-noted pre-consultation meeting held on August 23, 2023.

Pre-Consultation Preliminary Assessment

1 <input type="checkbox"/>	2 <input type="checkbox"/>	3 <input type="checkbox"/>	4 <input checked="" type="checkbox"/>	5 <input type="checkbox"/>
----------------------------	----------------------------	----------------------------	---------------------------------------	----------------------------

One (1) indicates that considerable major revisions are required while five (5) suggests that the proposal appears to meet the City's key land use policies and guidelines. This assessment is purely advisory and does not consider technical aspects of the proposal or in any way guarantee application approval.

Next Steps

1. A review of the proposal and materials submitted for the above-noted pre-consultation has been undertaken. Please proceed to complete a Phase 2 Pre-consultation Application Form and submit it together with the necessary studies and/or plans to planningcirculations@ottawa.ca.
2. In your subsequent pre-consultation submission, please ensure that all comments or issues detailed herein are addressed. A detailed cover letter stating how each issue has been addressed must be included with the submission materials. Please coordinate the numbering of your responses within the cover letter with the comment number(s) herein.
3. Please note, if your development proposal changes significantly in scope, design, or density before the Phase 3 pre-consultation, you may be required to repeat the Phase 2 pre-consultation process.

Supporting Information and Material Requirements

1. The attached **Study and Plan Identification List** (SPIL) outlines the information and material that has been identified, during this phase of pre-consultation, as either required (R) or advised (A) as part of a future complete application submission.

- a. The required plans and studies must meet the City's Terms of Reference (ToR) and/or Guidelines, as available on Ottawa.ca. These ToR and Guidelines outline the specific requirements that must be met for each plan or study to be deemed adequate.

Consultation with Technical Agencies

1. You are encouraged to consult with technical agencies early in the development process and throughout the development of your project concept. A list of technical agencies and their contact information is enclosed.

Planning (Tracey Scaramozzino, Mitch Lesage – Zoning):

Basic Understanding of the Site and proposed development:

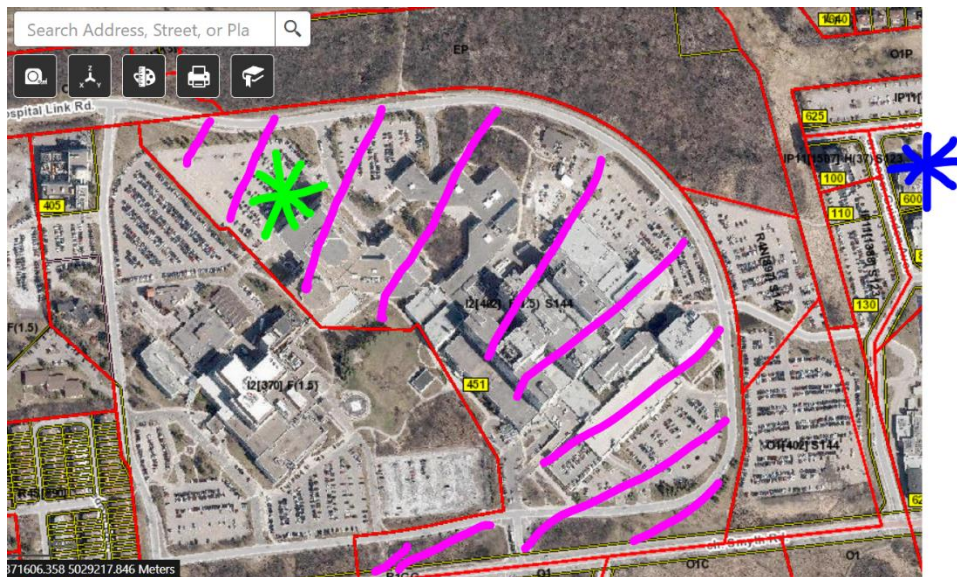

Green star is proposed new AMRC bldg and the pink is the 'one lot for zoning purposes (if we are only looking at TOH – General Campus – but there is the possibility of including the CHEO site immediately to the west). The Peter Morand site is the blue star and is not on the same lot for zoning purposes.

1. Site is part of TOH – General Campus. It was determined (in Dec 2022 pre pre con notes) that the site of 451 Smyth would be reviewed as one site for zoning purposes (S. 93) – since the entire property (despite the various bldgs and roads etc) functions as one lot and was developed together.
2. One option for the AMRC building is to request a MV for the site to allow:

- a. Reduced parking for the AMRC bldg
 - b. To permit parking for AMRC bldg to be located away from the bldg
- Note:** City staff cannot guarantee a positive decision from the cofa panel
- 3. The Peter M site would need to be rezoned to allow it to be used as a parking lot (for the AMRC bldg)

Questions from the Applicant for the Phase 1 precon, Aug 23, 2023:

- 1. **Confirmation that the AMRC building would be considered a “post-secondary educational institution” at 451 Smyth.**
 - City Response: At the Aug 23, 2023 Phase 1 Preconsultation meeting, the Applicant provided confirmation that this facility functions as a Post-secondary educational institution – as described in the Zoning Definition outlined below. If the site needs to be rezoned – the Applicant could consider adding in the R&D use, but this is not necessary for the current proposal.

Post-secondary educational institution includes a:

- 1. university which means a **place** of higher education, which has a body of teachers and students on the premises, and that offers instruction at the undergraduate level, post-graduate level, or both, and which is empowered by law to grant a degree upon the successful completion of a prescribed course of study;
- 2. college which means a college of applied arts and technology or other similar **place** of post secondary education which has a body of teachers and students on the premises, and that provides instruction in business, a trade, or a craft; and that is empowered by law to grant diplomas, licenses or certificates that permit the holders to represent themselves as qualified to work in a particular trade or occupation; or
- 3. any **residential use buildings, dwelling units or rooming units ancillary** to and located on the same lot as a university or college. (établissement d'enseignement postsecondaire)

- 2. **Can the overflow proposed Parking lot at 630 Peter Morand Crescent be considered accessory parking to the proposed use at 451 Smyth?**

- City Response: The lot at 630 Peter Morand could not be considered as ‘accessory parking’. The 630 Peter Morand site would be a parking lot and would have a clause on title to confirm that XXX spaces were for the developments at 451 Smyth (including the RGN and AMRC buildings and others). This ‘parking lot’ use would require a rezoning application.
- Other Brainstorming ideas to assist with timing (to start construction on the AMRC building soon, which likely then puts parking numbers into non-compliance as per zoning):
 - o Applicant to consider applying for MV to reduce the parking rate for 451 Smyth. City staff can’t be sure that the cofa panel would be supportive, esp since it is a public process and nearby residents may have concerns over over-flow parking on the local streets.

- Applicant to determine if they are OVER-providing parking at 451 Smyth – that they can then allocate to the new building
- City staff are reviewing if this file can be fast-tracked with High Economic Impact Project (HEIP) process

3. Is there another option to allow a parking lot on Peter Morand to be tied to the proposed AMRC use without needing another development application approval? Would an internal bus service from another lot help resolve this issue?

- The Peter M site would need to be rezoned to allow for a parking lot – and then it would be tied to the 451 Smyth/AMRC bldg.
- I don't believe there is a way to avoid another devt application.
- The bus idea would be useful to make the sites function together and would make the request to reduce the parking on site at the AMRC bldg more amenable, but won't help in the zoning provisions to allow the site to be used as a parking lot.

4. The December 2022 Pre consultation meeting minutes referred to “the point in the top left corner is a rear point” for 451 Smyth. Please confirm what this means in relation to the rear yard setback zoning requirement. Please note that the Ring Road is privately owned.

- City Response: Pls refer to marked-up drawing below. The rear lot is the blue point in the north-west corner. The rear yard setback would be drawn out as a straight line from the centre – as shown in dark blue. The front lot line is along Smyth and shown in pink and the remaining lines are interior lot lines and shown in green.
- If CHEO and TOH are under the same 'ownership', the lot line would change to the dashed green line to the west and then the light-blue point and arc would be the rear lot point and setback.

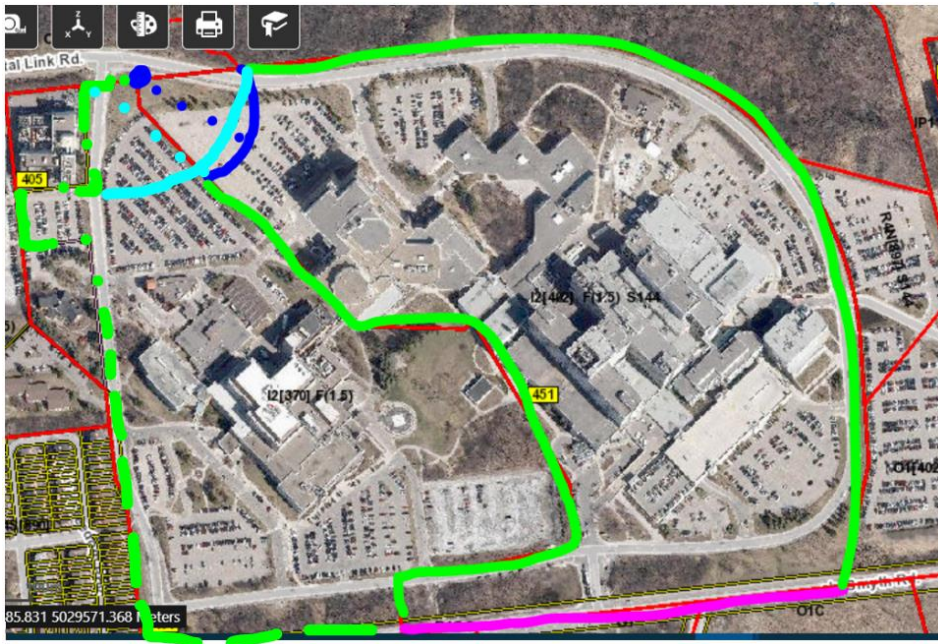

5. Please confirm that the minimum parking space rate for a post secondary educational institution of 0.75 m per 100 m² of gross floor area would be applied for both 451 Smyth and 630 Peter Morand only.

- City Response: With the AMRC bldg being considered a post-secondary facility, then that parking rate would be used for the amount of req'd parking at the site as well as what is allocated to the AMRC bldg

6. Do we need to use the minimum parking space rate shown in Section 206, provision 11(h) for 630 Peter Morand ?

(h) parking must be provided for all uses at the rate of one space per 100 square metres of gross floor area;

- City Response: 11(h) above does not apply, as that would only be for uses that located on that site. If this site is rezoned as a parking lot for 451 Smyth, the parking rate would be the requirement for the post-secondary institution – as the spaces would be tied to AMRC building. - BUT – the parking lot doesn't have a GFA so this wouldn't apply...

7. The construction of the AMRC building at 451 Smyth will result in the removal of the parking lot that currently services the existing RGN building, which is adjacent to the site. Does the proposed parking lot at 630 Peter Morand need to be operational before decommissioning the existing parking lot at 451

Smyth? If yes, would the 630 Peter Morand parking be considered a permanent or a temporary lot?

- City Response: If REQD parking is being removed and can't be located elsewhere at 451 Smyth (possibly adding additional spaces if required/possible – including smaller car sizes if appropriate), then yes, Peter M parking lot needs to be up 1st (zoning in place and parking lot built);

TOH (George): explained that the 630 Peter Morand site was conveyed to university for development. He will forward the conveyance agreement in case there is an opportunity to develop the site for a parking lot without the zoning requirement for the parking lot use. (630 Peter M has a building and a surface parking lot and part of the lot is also vacant grassed lands.)

if there is no where else for the vehicular parking at 451 Smyth Road, then yes, the lot at 630 Peter M would need to be operational. I presume it would be a permanent parking lot, as it will be needed on a permanent basis for the existing RGN bldg and the proposed AMRC bldg.

8. Regarding the list of plans and studies, we would like to understand where the City is at with the revisions to the Terms of Reference.

- City Response: The TOR's have been updated and are on the City's website.

9. What would be needed in a Zoning Conformance Report that wouldn't be provided in a Planning Rationale?

- City Response: the Zoning Conformance Report should go through every provision of the Zoning By-Law that applies to this site. It may or may not be the same as what you already provide in the Planning Rationale.

10. Confirmation that we don't need to go through the UDRP process.

- City Response: no requirement for UDRP, as it is not within a 'design priority area' in Schedule C7-A.

11. Confirmation of Phases 2 and 3 requirements and timing, under the City's new multi-tiered pre application consultation process.

- City Response: Our goal is to conduct a meeting within 10 business days and provide feedback to the Applicant in 3 business days for phases 1 and 2. Phase 3

allows the City 10 business days for internal review against the City's TOR and to provide feedback in 5 business days. These timelines are NOT regulated and will strive to meet them.

- Phase 2 is required to discuss the parking situation and whether the Rezoning is required for the parking lot at 630 Peter Morand and also to review the conveyance agreement with the City and the High Economic Impact Project opportunity.

Urban Design (Nader Kadri):

- o Formal comments not received.

Engineering (Tyler Cassidy):

1. The Stormwater Management Criteria, for the subject site located at **451 Smyth Road**, is to be based on the following:
 - a. The 2-yr & 5-yr storm event using the IDF information derived from the Meteorological Services of Canada rainfall data, taken from the MacDonald Cartier Airport, collected 1966 to 1997.
 - b. Flows to the storm sewer in excess of the allowable storm release rate, up to and including the 100-year storm event, must be detained on site.
 - c. The City of Ottawa requires, at minimum, controlling the post-development flows to the pre-development peak flow during the 5-year event. The applicant has stated that the Ottawa Hospital General Campus has more restrictive SWM criteria, with a recommended post-development release rate being controlled to the pre-development 2 year storm event.
 - d. The pre-development runoff coefficient or a maximum equivalent 'C' of 0.5, whichever is less (§ 8.3.7.3).
 - e. A calculated time of concentration (Cannot be less than 10 minutes).
 - f. Quality control is to be provided on-site to the 'enhanced' criteria (80% TSS removal). Records show that there is an existing OGS unit providing some level of quality control downstream the site on Hospital Link Road. It is the consultant/applicant's responsibility to confirm what level of service is being provided by existing infrastructure downstream, and to provide detailed OGS sizing calculations that confirm an overall TSS removal of 80% is being achieved. Any shortfall in TSS removal from the existing OGS unit is expected to be made up on site.

- a. 305mm dia. PVC Watermain on Peter Morand Crescent.
 - b. 250 mm dia. PVC sewer on Peter Morand Crescent.
 - c. Existing 750 mm dia. Conc. STM sewer on Peter Morand Crescent.
5. General Servicing Comments:
- d. Connections to trunk sewers and easement sewers are typically not permitted.
 - e. A sanitary monitoring maintenance hole is required if the sanitary service connects to a *public* sanitary sewer. The monitoring maintenance hole should be located in an accessible location on private property near the property line (ie. Not in a parking area). If the proposed sanitary service connects to a *private* sanitary sewer, a monitoring maintenance hole will not be required.
 - f. Sewer connections to be made above the springline of the sewermain as per:
 - i. Std Dwg S11.1 for flexible main sewers – connections made using approved tee or wye fittings.
 - ii. Std Dwg S11 (For rigid main sewers) – lateral must be less than 50% the diameter of the sewermain,
 - iii. Std Dwg S11.2 (for rigid main sewers using bell end insert method) – for larger diameter laterals where manufactured inserts are not available; lateral must be less than 50% the diameter of the sewermain,
 - iv. Connections to manholes permitted when the connection is to rigid main sewers where the lateral exceeds 50% the diameter of the sewermain. – Connect obvert to obvert with the outlet pipe unless pipes are a similar size.
 - v. No submerged outlet connections.
6. Water Boundary condition requests must include the location of the service (map or plan with connection location(s) indicated) and the expected loads required by the proposed development, including calculations. Please provide the following information:
- a. Location of service
 - b. Type of development and the amount of fire flow required (as per FUS).
 - c. Average daily demand: ____ l/s.

- d. Maximum daily demand: ___ l/s.
 - e. Maximum hourly daily demand: ___ l/s.
7. An MECP Environmental Compliance Approval **Industrial Sewage Works or Private Sewage Works** maybe required for the proposed development. Please contact the Ministry of the Environment, Conservation and Parks, Ottawa District Office to arrange a pre-submission consultation:
- f. Emily Diamond at (613) 521-3450, ext. 238 or Emily.Diamond@ontario.ca
8. Background studies include:
- a. **451 Smyth Road:** “Design Brief – Hospital Link Storm Drainage System Alta Vista Transportation Corridor” prepared by Delcan, consultant report no. T03016EOD, dated May 21, 2014.
 - b. **451 Smyth Road:** “Design Brief – Hospital Link Storm Drainage System Alta Vista Transportation Corridor ADDENDUM” prepared by Delcan, consultant report no. T03016EOD, dated August 13, 2014.
 - c. **630 Peter Morand Crescent:** Stormwater Management Report “Proposed Relocation of the Existing Stormwater Pond at the Ottawa Life Sciences Technology Park” prepared by Stantec, dated November 19, 2002, revised December 17, 2002.
9. Frontage Charges do not apply to this application.
10. There are no [Capital Works Projects](#) scheduled within the vicinity of this project.

Feel free to contact Tyler Cassidy, Infrastructure Project Manager, for follow-up questions.

Noise (Mike Giampa):

- 11. A Road Noise Impact Study is required

Feel free to contact Mike Giampa, TPM, for follow-up questions.

Transportation (Mike Giampa):

- 12. A TIA is warranted- proceed to scoping (step 2). Required modules can be adjusted at this step. The Scoping report must be submitted at Phase 2 precon (if applicable) or 14 calendar days prior to Phase 3 precon.

13. The application will not be deemed complete until the submission of the draft step 2-3. Synchro files are required at Step 3/Phase 3 precon for a complete submission.
14. Ensure that the clear throat requirements meet TAC guidelines (applies to arterial and collectors only).
15. A Road Noise Impact Study is required.
16. Ensure that the development proposal complies with the Right-of-Way protection requirements of the Official Plan's Schedule C16. The ROW protection will then be verified at submission. Any requests for exceptions to ROW protection requirements must be discussed with Transportation Planning and concurrence provided by Transportation Planning management.
 - i. See [Schedule C16 of the Official Plan](#).
17. Any requests for exceptions to ROW protection requirements must be discussed with Transportation Planning and concurrence provided by Transportation Planning management.

Feel free to contact Mike Giampa, Transportation Project Manager, for follow-up questions.

Environment and Trees

1. Comments not received.

Feel free to contact Matthew Hayley, Environmental Planner, or Mark Richardson, Forester, for follow-up questions.

Parkland (Steve Gauthier):

18. Cash-in-lieu of parkland will be required as per the Parkland Dedication Bylaw
 - a. Parkland Dedication [By-law No. 2022-280](#)

Feel free to contact Steve Gauthier, Parks Planner, for follow-up questions.

Conservation Authority (RVCA – Eric Lalande)

19. Ensure the reduction of quantity control from 5yrs to 2yrs does not negatively impact erosion.

Feel free to contact Eric Lalande, RVCA, for follow-up questions.

Other

20. For the Site Plan Control stage: The High Performance Development Standard (HPDS) is a collection of voluntary and required standards that raise the performance of new building projects to achieve sustainable and resilient design. The HPDS was passed by Council on April 13, 2022.
 - a. At this time, the HPDS is not in effect and Council has referred the 2023 HPDS Update Report back to staff with direction to bring forward an updated report to Committee with recommendations for revised phasing timelines, resource requirements and associated amendments to the Site Plan Control By-law by no later than Q1 2024.
 - b. Please refer to the HPDS information attached and ottawa.ca/HPDS for more information.
21. The City is reviewing this application for potential “High Economic Impact Process – HEIP” which would help to speed the file through the approval process. The File Lead or the HEIP team (while the file lead is away Sept 2-Sept 18) will advise if the file is selected.

Submission Requirements and Fees

1. The attached **Study and Plan Identification List** (SPIL) outlines the information and material that has been identified as either required (R) or advised (A) as part of a future complete application submission.
 - a. The required plans and studies must meet the City’s Terms of Reference (ToR) and/or Guidelines, as available on Ottawa.ca. These ToR and Guidelines outline the specific requirements that must be met for each plan or study to be deemed adequate.
2. All of the above comments or issues should be addressed to ensure the effectiveness of the application submission review.



Should there be any questions, please do not hesitate to contact myself or the contact identified for the above areas / disciplines.

Yours Truly,
Tracey Scaramozzino

cc.
City contacts, as per above

APPENDIX

B TECHNICAL DOCUMENTS



APPENDIX

B-1 *STORMWATER MANAGEMENT CALCULATIONS*

	Project	AMRC	No.	CA0009956.0165	
	By	FA	Date	2024-02-23	Page
	Checked	IS	Date	2024-02-23	1
Subject	SWM Design Criteria				

0.0 SWM Design Criteria

0.1 Jurisdictions

- 1 City of Ottawa
- 2 Ministry of Environment, Conservation and Parks (MECP)
- 3 Rideau Valley Conservation Authority

0.2 SWM Design Criteria

0.2.1 Water Quality

Provide an Enhance Level of Protection or 80% TSS removal, as per MOECC SWMPDM (2003)

0.2.4 Quantity Control

- 1) The post-development peak flow rates generated from the City's IDF Curves for 2 to 100-year storm events shall be controlled to pre-development levels as simulated with PCSWMM model.
- 2) The 2-100-year storm events modelled using the 3&6-hour Chicago storm shall be used the further evaluate the quantity control measures in the proposed conditions.

Drainage	Sub-watershed (CA)	Quantity Control Criteria			Reference & Notes		
		City*	CA	MTO	Hydrologic Model	Design Storm	Background Documents
-	-	Post to 2-yr Pre	Post to Pre	Post to Pre	PCSWMM	3&6 hr Chicago, City's IDF Curves	N/A

	Project	AMRC	No.	CA0009956.0165	
	By	FA	Date	2024-02-23	Page 2
	Checked	IS	Date	2024-02-23	

Subject **SWM Parameters**

1.0 Design Rainfall Event

1.1 Design Storm

IDF Curve City of Ottawa
3&6 hour Chicago

In general, the SCS design storm should be used for determining the hydrographs for undeveloped watersheds and for checking detention storages required for quantity control.

The Chicago design storms should be used for determining hydrographs in urban areas and also for checking detention storage. In many cases, the consultant will be required to run both sets of design storms to make sure that the more stringent is used for each individual element of the drainage system.

1.2 IDF Curves

Source of IDF: The City of Ottawa Accepted IDF Data

Equation:

$$I = \frac{A}{(t + C)^B}$$

Where, I = Rainfall Intensity (mm/hr)
t = Time of Concentration (minutes)
A, B, C = Constant Values for Storms with Various Return Period.

Return Period (Years)	A	B	C	Ottawa		
				Rainfall Amount (mm)		Intensity (mm/hr)
				3 Hour Chic	24 hour	10 min
2	733.0	0.810	6.199	12.1	12.2	76.8
5	998.1	0.814	6.053	16.5	16.6	104.2
10	1174.2	0.816	6.014	19.4	19.5	122.1
25	1402.9	0.819	6.018	23.2	23.3	144.7
50	1569.6	0.820	6.014	25.9	26.1	161.5
100	1735.7	0.820	6.014	28.7	28.8	178.6

Note:

- 1) The minimum initial time of concentration is to be 10 minutes
- 2) The 3&6 hour Chicago shall be used to further evaluate the quantity control performance of the SWM facilities.



Project	AMRC	No.	CA0009956.0165
By	FA	Date	2024-02-23
Checked	IS	Date	2024-02-23

Page	3
------	---

Subject

SWM Parameters

2.0 Soil Information

The Standard City of Ottawa Values were used for Infiltration Method (Horton)

2.1 PCSWMM Attributes- Horton

N Imperv	0.013
N Perv	0.25
Dstore Imperv (mm)	1.57
Dstore Perv (mm)	4.67
Max. Infil. Rate (mm/hr)	76.2
Min. Infil. Rate (mm/hr)	13.2
Decay Constant (1/hr)	4.14
Drying Time (days)	7



Calculation of existing runoff rate is undertaken using the Rational Method: Q = 2.78 CaCIA

- Where: Q = Peak flow rate (litres/second)
- Ca = Runoff coefficient adjustment factor (-)
- C = Runoff coefficient (-)
- I = Rainfall intensity (mm/hour)
- A = Catchment area (hectares)

Project Area, A hectares
 Runoff Coef, C 0.50

$$I = \frac{A}{(t + C)^B}$$

Where: A, B and C = Parameters defined in Section 5.4.2 of City of Ottawa Sewer Design Guidelines

- I = Rainfall intensity (mm/hour)
- t = Time of concentration (minutes)

Return Period (Years)	2	5	10	25	50	100
A	733.0	998.1	1,174.2	1,402.9	1,569.6	1,735.7
B	0.810	0.814	0.816	0.819	0.820	0.820
C	6.199	6.053	6.014	6.018	6.014	6.014
T (mins) *	10	10	10	10	10	10
I (mm/hr)	76.8	104.2	122.1	144.7	161.5	178.6
C Multiplier (OSDG Table 5.7)	1.00	1.00	1.00	1.10	1.20	1.25
Adjusted C** (-)	0.50	0.50	0.50	0.55	0.60	0.63
Q (litres/sec)	215.7	292.6	342.9	446.9	544.1	626.7
Q (m3/sec)	0.216	0.293	0.343	0.447	0.544	0.627

*Note: For a small site (<2.0ha), a time of concentration of 10 minutes was assumed for the calculations

**Note: Please refer to the "Runoff Coefficient Adjustment Calculations" calculation page for more details



Stormwater Management Calculations

Project: ARMC

No.: CA0009956.0165

Area Takeoff and Runoff Coefficient Adjustment Calculations

By: FA

Date: 2024-02-23

Checked: IS

Page:
5

Post-Development Conditions - A-1 Uncontrolled

Land Use	Area (m ²)	IMP(%)	% Coverage	Width (m)
Soft Landscaping	124	0.0%	2.19%	13
At-Grade Impervious	318	100.0%		
Total Area	442	71.9%		

Post-Development Conditions - A-4 Controlled

Land Use	Area (m ²)	IMP(%)	% Coverage	Width (m)
Soft Landscaping	1199	0.0%	7.37%	14
At-Grade Impervious	285	100.0%		
Total Area	1485	19.2%		



Stormwater Management Calculations

Project: ARMC

No.: CA0009956.0165

Area Takeoff and Runoff Coefficient Adjustment Calculations

By: FA

Date: 2024-02-23

Checked: IS

Page:
6

Post-Development Conditions - A-5 Uncontrolled

Land Use	Area (m ²)	IMP(%)	% Coverage	Width (m)
Soft Landscaping	312	0.0%	1.55%	8
At-Grade Impervious	0	100.0%		
Total Area	312	0.0%		

Post-Development Conditions - A-6 Controlled

Land Use	Area (m ²)	IMP(%)	% Coverage	Width (m)
Soft Landscaping	845	0.0%	5.08%	21
At-Grade Impervious	178	100.0%		
Total Area	1023	17.4%		

Post-Development Conditions - A-7 Controlled

Land Use	Area (m ²)	IMP(%)	% Coverage	Width (m)
Soft Landscaping	54	0.0%	2.92%	21
At-Grade Impervious	535	100.0%		
Total Area	589	90.8%		

Post-Development Conditions - A-8 Controlled

Land Use	Area (m ²)	IMP(%)	% Coverage	Width (m)
Soft Landscaping	15	0.0%	2.18%	15
At-Grade Impervious	425	100.0%		
Total Area	439	96.6%		



Stormwater Management Calculations

Project: ARMC

No.: CA0009956.0165

Area Takeoff and Runoff Coefficient Adjustment Calculations

By: FA

Date: 2024-02-23

Page: 7

Checked: IS

Post-Development Conditions - A-9 Controlled

Land Use	Area (m ²)	IMP(%)	% Coverage	Width (m)
Soft Landscaping	0	0.0%	1.66%	21
At-Grade Impervious	335	100.0%		
Total Area	335	100.0%		

Post-Development Conditions - A-10 Controlled

Land Use	Area (m ²)	IMP(%)	% Coverage	Width (m)
Soft Landscaping	29	0.0%	1.29%	14
Impervious at Grade	231	100.0%		
Total Area	259	88.9%		

Post-Development Conditions - A-11 Controlled

Land Use	Area (m ²)	IMP(%)	% Coverage	Width (m)
Soft Landscaping	61	0.0%	2.10%	12
Impervious at Grade	364	100.0%		
Total Area	424	85.7%		

Post-Development Conditions - A-12 Controlled

Land Use	Area (m ²)	IMP(%)	% Coverage	Width (m)
Soft Landscaping	287	0.0%	5.16%	22
Impervious at Grade	753	100.0%		
Total Area	1039	72.4%		



Stormwater Management Calculations

Project: ARMC

No.: CA0009956.0165

Area Takeoff and Runoff Coefficient Adjustment Calculations

By: FA

Date: 2024-02-23

Page: 8

Checked: IS

Post-Development Conditions - A-13 Controlled

Land Use	Area (m ²)	IMP(%)	% Coverage	Width (m)
Soft Landscaping	18	0.0%	2.36%	17
Impervious at Grade	457	100.0%		
Total Area	475	96.1%		

Post-Development Conditions - A-14 Controlled

Land Use	Area (m ²)	IMP(%)	% Coverage	Width (m)
Soft Landscaping	153	0.0%	3.48%	22
Impervious at Grade	549	100.0%		
Total Area	701	78.2%		

Post-Development Conditions - A-15 Controlled

Land Use	Area (m ²)	IMP(%)	% Coverage	Width (m)
Soft Landscaping	114	0.0%	2.82%	17
Impervious at Grade	455	100.0%		
Total Area	569	79.9%		

Post-Development Conditions - A-16 Controlled

Land Use	Area (m ²)	IMP(%)	% Coverage	Width (m)
Soft Landscaping	125	0.0%	3.20%	21
Impervious at Grade	520	100.0%		
Total Area	646	80.6%		



Stormwater Management Calculations

Project: ARMC

No.: CA0009956.0165

Area Takeoff and Runoff Coefficient Adjustment Calculations

By: FA

Date: 2024-02-23

Page: 9

Checked: IS

Post-Development Conditions - A-17 Controlled

Land Use	Area (m ²)	IMP(%)	% Coverage	Width (m)
Soft Landscaping	69	0.0%	7.06%	32
Impervious at Grade	1354	100.0%		
Total Area	1424	95.1%		

Post-Development Conditions - A-18 Controlled

Land Use	Area (m ²)	IMP(%)	% Coverage	Width (m)
Soft Landscaping	116	0.0%	7.55%	30
Impervious at Grade	1406	100.0%		
Total Area	1522	92.3%		

Post-Development Conditions - A-19 Uncontrolled

Land Use	Area (m ²)	IMP(%)	% Coverage	Width (m)
Soft Landscaping	84	0.0%	0.99%	10
Impervious at Grade	116	100.0%		
Total Area	200	58.0%		

Post-Development Conditions - A-20 Controlled

Land Use	Area (m ²)	IMP(%)	% Coverage	Width (m)
Soft Landscaping	259	0.0%	2.77%	11
Impervious at Grade	299	100.0%		
Total Area	558	53.6%		



Stormwater Management Calculations

Project: ARMC

No.: CA0009956.0165

Area Takeoff and Runoff Coefficient Adjustment Calculations

By: FA

Date: 2024-02-23

Checked: IS

Page:
10

Post-Development Conditions - A-21 Controlled

Land Use	Area (m ²)	IMP(%)	% Coverage	Width (m)
Soft Landscaping	293	0.0%	3.72%	22
Impervious at Grade	456	100.0%		
Total Area	749	60.9%		

Post-Development Conditions - A-22 Controlled

Land Use	Area (m ²)	IMP(%)	% Coverage	Width (m)
Soft Landscaping	173	0.0%	2.99%	14
Impervious at Grade	430	100.0%		
Total Area	603	71.3%		

Post-Development Conditions - A-23 Controlled

Land Use	Area (m ²)	IMP(%)	% Coverage	Width (m)
Soft Landscaping	109	0.0%	4.95%	20
Impervious at Grade	888	100.0%		
Total Area	997	89.1%		

Post-Development Conditions - R-1 Controlled

Land Use	Area (m ²)	IMP(%)	% Coverage	Width (m)
Impervious Roof	4167	100.0%	20.67%	62
Total Area	4167	100.0%		

Post-Development Conditions - R-2 Uncontrolled

Land Use	Area (m ²)	IMP(%)	% Coverage	Width (m)
Impervious Roof	1198	100.0%	5.94%	35
Total Area	1198	100.0%		



Stormwater Management Calculations	Project: ARMC	No.:	CA0009956.0165	
	Catchbasin Storage and Surface Ponding	By: FA	Date:	2024-02-23
		Checked: IS		

Catchbasin Number	Catchment	ICD	100-yr			
			Catch Basin Volume	Surface Ponding Volume	Surface Ponding Depth	Depth in Catch Basin
			(m3)	(m3)	(m)	(m)
CB1	17	175 mm Plate for Pond	0.1379	0	0.00	0.3831
CB2	15		0.038	0	0.00	0.105
CB3	14		0.042	0	0.00	0.117
CB4	20		0.107	0	0.00	0.2974
CB5	12		0.1297	0	0.00	0.3602
CB6	13		0.08125	0	0.00	0.2257
CB7	23	125 mm Plate	0.7452	0.1178	0.02	2.070
CB8	21	175 mm Plate for Pond	0.1945	0	0.00	0.5404
CB12	11	HydroVex	0.3396	0	0.00	0.9433
CB13	22	175 mm Plate for Pond	0.2197	0	0.00	0.6103
CB14	7	HydroVex	0.2748	0	0.00	0.76
CB15	4	HydroVex	0.3			0.83
CB20	18	175 mm Plate for Pond	0.2382	0	0.00	1.061
EXCB02	16		0.04958	0	0.00	0.1377

Flow Through Orifice

ICD Location	ICD	100-yr	
		Head	Flow
		(m)	(m3/s)
CB7	125 mm Plate	2.091	0.049
Pond Outlet	175 mm Plate	1.378	0.075
MH112-Chamber	Hydrovex 100-VHV-1	1.923	0.004



The location, number, and weir exposure of each roof drain was determined by the mechanical design team. This information has been inputted into PCSWMM

Roof drain	Area (m ²)	Runoff Coefficient	Depth (m)	Theoretical rooftop storage volume (m ³)	Storage volume (m ³)	Max flow rate (l/s)	Weir Exposure
1	93.67	0.90	0.15	14.05	11.24	0.32	Closed
2	125.58	0.90	0.15	18.84	15.07	0.32	Closed
3	128.33	0.90	0.15	19.25	15.40	0.32	Closed
4	123.95	0.90	0.15	18.59	14.87	1.89	Fully Open
5	123.98	0.90	0.15	18.60	14.88	0.32	Closed
6	122.60	0.90	0.15	18.39	14.71	0.32	Closed
7	84.62	0.90	0.15	12.69	10.15	0.32	Closed
8	81.94	0.90	0.15	12.29	9.83	0.32	Closed
9	117.95	0.90	0.15	17.69	14.15	0.32	Closed
10	100.58	0.90	0.15	15.09	12.07	0.32	Closed
11	103.48	0.90	0.15	15.52	12.42	1.89	Fully Open
12	109.12	0.90	0.15	16.37	13.09	0.32	Closed
13	114.63	0.90	0.15	17.19	13.76	0.32	Closed
14	85.18	0.90	0.15	12.78	10.22	0.32	Closed
15	126.66	0.90	0.15	19.00	15.20	0.32	Closed
16	162.34	0.90	0.15	24.35	19.48	0.32	Closed
17	120.31	0.90	0.15	18.05	14.44	0.32	Closed
18	147.54	0.90	0.15	22.13	17.70	0.32	Closed
19	149.81	0.90	0.15	22.47	17.98	1.89	Fully Open
20	94.25	0.90	0.15	14.14	11.31	1.89	Fully Open
21	78.86	0.90	0.15	11.83	9.46	0.32	Closed
22	65.59	0.90	0.15	9.84	7.87	0.32	Closed
23	48.06	0.90	0.15	7.21	5.77	0.32	Closed
24	99.71	0.90	0.15	14.96	11.97	0.32	Closed
25	93.70	0.90	0.15	14.06	11.24	0.32	Closed
26	113.87	0.90	0.15	17.08	13.66	0.32	Closed
27	114.89	0.90	0.15	17.23	13.79	0.32	Closed
28	111.31	0.90	0.15	16.70	13.36	1.89	Fully Open
29	129.66	0.90	0.15	19.45	15.56	0.32	Closed
30	87.94	0.90	0.15	13.19	10.55	0.32	Closed
31	50.02	0.90	0.15	7.50	6.00	0.32	Closed
32	50.81	0.90	0.15	7.62	6.10	0.32	Closed
33	90.80	0.90	0.15	13.62	10.90	0.32	Closed
34	102.96	0.90	0.15	15.44	12.36	0.32	Closed
35	121.60	0.90	0.15	18.24	14.59	1.89	Fully Open
36	106.63	0.90	0.15	15.99	12.80	0.32	Closed
37	76.33	0.90	0.15	11.45	9.16	0.32	Closed
Total	3859.26				463.11	21.26	



Stormwater Management Calculations	Project: AMRC	No.: CA0009956.0165	
	Proposed Quality Control	By: FA	Date: 2024-02-26
	Checked: IS	Page: 13	

Water Quality Design Criteria Require long-term average removal of 80% TSS on an annual loading basis from all runoff leaving the site.

Water Quality Strategies

Two EFO OGS units is proposed to treat runoff . Please note OGSs provide 60% TSS removal
 An existing OGS is proposed to treat all runoff . Please note the OGS provides 50% TSS removal
 An isolator row is proposed to treat all runoff . Please note the row provides 80% TSS removal

TSS Removal Catchments A-4,A-7 to A-11

Total Area 0.35 ha

Treatment Train Approach (New Jersey Equation)

R=A+B-[(AXB)/100]

R= Total TSS Removal Rate

A= TSS Removal Rate of the first BMP ROW 80% TSS Removal

B= TSS Removal Rate of the Second BMP EFO 60% TSS Removal

R= 80+60-(80 x 60/100)= 92

A= TSS Removal Rate of the first BMP ROW+EFO 92% TSS Removal

B= TSS Removal Rate of the Second BMP OGS 50% TSS Removal

R= 92+50-(92 x 50/100)= 96

TSS Removal Catchments A-6, A-12 to A-18, and A-20 to A-22

Total Area 0.93 ha

R= Total TSS Removal Rate

A= TSS Removal Rate of the first BMP EFO 60% TSS Removal

B= TSS Removal Rate of the Second BMP OGS 50% TSS Removal

R= 60+50-(60 x 50/100)= 80

TSS Removal Catchments A-1, A-5, A-19, and A-23

Total Area 0.20 ha

All Runoff from the Site is treated by the existing Downstream Vortech Unit. Thw unit provides 50% TSS removal

TSS Removal 50 %

TSS Removal Catchments R-1 and R-2

Total Area 0.54 ha

Runoff from roof surfaces is considered clean

TSS Removal 80 %

Total TSS Removal

Catchment	Area (ha)	TSS removal (%)
A-4,A-7 to A-11	0.35	96
A-6, A-12 to A-18, and A-20 to A-22	0.93	80
A-1, A-5, A-19, and A-23	0.20	50
R-1 and R-2	0.54	80
Total	2.02	80

Therefore the total TSS removal across the site is 80%

APPENDIX

B-2 PCSWMM OUTPUT

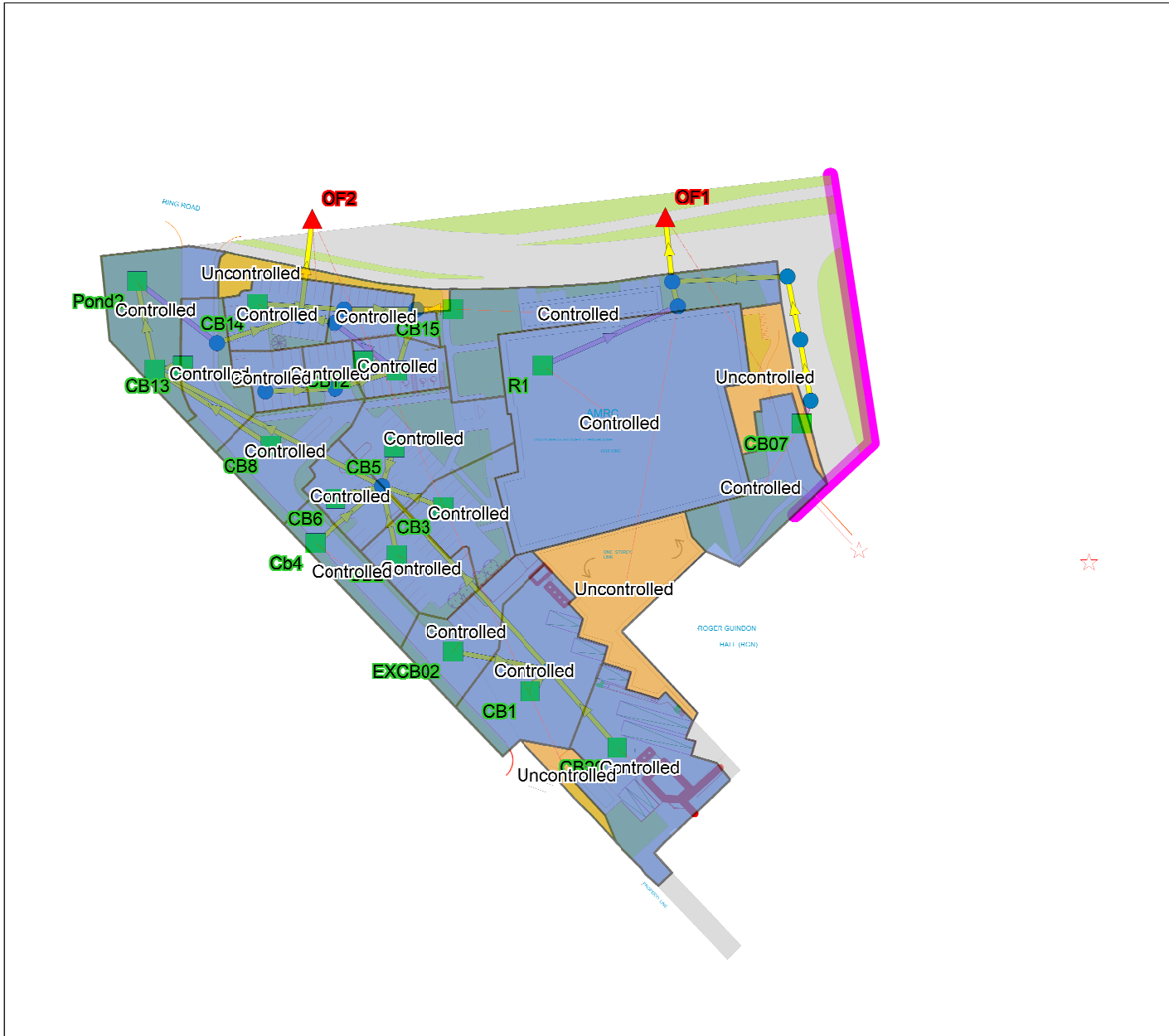

Legend

- ▲ Outfalls
- Subcatchments
- Visible
- Visible
- Junctions
- Visible
- GUID
- PR
- EX
- EX_WTE
- Storages
- Conduits
- Visible
- GUID
- PR
- EX
- EX_WTE
- major
- Outlets
- Landuse-PR
- PERV
- IMPERV
- CA0009956.0165-CA_ARCH_AMRC



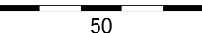

```

[Title]
;;Project Title/Notes

[Options]
;;Option Value
FLOW_UNITS CMS
INFILTRATION HORTON
FLOW_ROUTING DYNWAVE
LINK_OFFSETS ELEVATION
MIN_SLOPE 0
ALLOW_PONDING YES
SKIP_STEADY_STATE NO

START_DATE 07/23/2009
START_TIME 00:01:00
REPORT_START_DATE 07/23/2009
REPORT_START_TIME 00:01:00
END_DATE 07/23/2009
END_TIME 14:01:00
SWEEP_START 01/01
SWEEP_END 12/31
DRY_DAYS 0
REPORT_STEP 00:05:00
WET_STEP 00:05:00
DRY_STEP 00:05:00
ROUTING_STEP 1
RULE_STEP 00:00:00

INERTIAL_DAMPING FULL
NORMAL_FLOW_LIMITED BOTH
FORCE_MAIN_EQUATION H-W
VARIABLE_STEP 0.75
LENGTHERNING_STEP 0
MIN_SURFAREA 0
MAX_TRIALS 20
HEAD_TOLERANCE 0.0015
SYS_FLOW_TOL 5
LAT_FLOW_TOL 5
MINIMUM_STEP 0.5
THREADS 2

```

```

[EVAPORATION]
;;Data Source Parameters
CONSTANT 0.0
DRY_ONLY NO

[TEMPERATURE]
TIMESERIES 100yr_6hr_Chicago
WINDSPEED MONTHLY 0.0 0.0 0.0 0.0 0.0 0.0 0.0 0.0 0.0 0.0 0.0 0.0
SNOWMELT 34 0.5 0.6 0.0 50.0 0.0
ADC IMPERVIOUS 1.0 1.0 1.0 1.0 1.0 1.0 1.0 1.0 1.0 1.0 1.0
ADC PERVIOUS 1.0 1.0 1.0 1.0 1.0 1.0 1.0 1.0 1.0 1.0 1.0

```

```

[RAINGAGES]
;;Name Format Interval SCF Source
100yr_3hr_Chicago INTENSITY 0:10 1 TIMESERIES 100yr_3hr_Chicago
100yr_3hr_Chicago_Climate_Change INTENSITY 0:10 1.0 TIMESERIES
100yr_3hr_Chicago_Increase_20percent INTENSITY 0:10 1.0 TIMESERIES
100yr_6hr_Chicago INTENSITY 0:10 1 TIMESERIES 100yr_6hr_Chicago
100yr_6hr_Chicago_Climate_Change INTENSITY 0:10 1.0 TIMESERIES
100yr_6hr_Chicago_Increase_20percent INTENSITY 0:10 1.0 TIMESERIES

```

```

R-2 0 Chicago_6h100-yr ROOF 0.1198 100 35

[SUBAREAS]
;;Subcatchment N-Imperv N-Perv S-Imperv S-Perv PctZero RouteTo
A-1 0.013 0.25 1.57 4.67 25 OUTLET
A-10 0.013 0.25 1.57 4.67 25 OUTLET
A-11 0.013 0.25 1.57 4.67 25 OUTLET
A-12 0.013 0.25 1.57 4.67 25 OUTLET
A-13 0.013 0.25 1.57 4.67 25 OUTLET
A-14 0.013 0.25 1.57 4.67 25 OUTLET
A-15 0.013 0.25 1.57 4.67 25 OUTLET
A-16 0.013 0.25 1.57 4.67 25 OUTLET
A-17 0.013 0.25 1.57 4.67 25 OUTLET
A-18 0.013 0.25 1.57 4.67 25 OUTLET
A-19 0.013 0.25 1.57 4.67 25 OUTLET
A-20 0.013 0.25 1.57 4.67 25 OUTLET
A-21 0.013 0.25 1.57 4.67 25 OUTLET
A-22 0.013 0.25 1.57 4.67 25 OUTLET
A-23 0.013 0.25 1.57 4.67 25 OUTLET
A-4 0.013 0.25 1.57 4.67 25 OUTLET
A-5 0.013 0.25 1.57 4.67 25 OUTLET
A-6 0.013 0.25 1.57 4.67 25 OUTLET
A-7 0.013 0.25 1.57 4.67 25 OUTLET
A-8 0.013 0.25 1.57 4.67 25 OUTLET
A-9 0.013 0.25 1.57 4.67 25 OUTLET
R-1 0.013 0.25 1.57 4.67 25 OUTLET
R-2 0.013 0.25 1.57 4.67 25 OUTLET

[INFILTRATION]
;;Subcatchment Param1 Param2 Param3 Param4 Param5
A-1 76.2 13.2 4.14 7 0
A-10 76.2 13.2 4.14 7 0
A-11 76.2 13.2 4.14 7 0
A-12 76.2 13.2 4.14 7 0
A-13 76.2 13.2 4.14 7 0
A-14 76.2 13.2 4.14 7 0
A-15 76.2 13.2 4.14 7 0
A-16 76.2 13.2 4.14 7 0
A-17 76.2 13.2 4.14 7 0
A-18 76.2 13.2 4.14 7 0
A-19 76.2 13.2 4.14 7 0
A-20 76.2 13.2 4.14 7 0
A-21 76.2 13.2 4.14 7 0
A-22 76.2 13.2 4.14 7 0
A-23 76.2 13.2 4.14 7 0
A-4 76.2 13.2 4.14 7 0
A-5 76.2 13.2 4.14 7 0
A-6 76.2 13.2 4.14 7 0
A-7 76.2 13.2 4.14 7 0
A-8 76.2 13.2 4.14 7 0
A-9 76.2 13.2 4.14 7 0
R-1 76.2 13.2 4.14 7 0
R-2 76.2 13.2 4.14 7 0

[LID_CONTROLS]
;;Name Type/Layer Parameters

```

```

10yr_3hr_Chicago INTENSITY 0:10 1 TIMESERIES 10yr_3hr_Chicago
10yr_6hr_Chicago INTENSITY 0:10 1 TIMESERIES 10yr_6hr_Chicago
25mm_3hr_Chicago INTENSITY 0:10 1.0 TIMESERIES 25mm_3hr_Chicago
25mm_4hr_Chicago INTENSITY 0:10 1.0 TIMESERIES 25mm_4hr_Chicago
25yr_3hr_Chicago INTENSITY 0:10 1 TIMESERIES 25yr_3hr_Chicago
25yr_6hr_Chicago INTENSITY 0:10 1 TIMESERIES 25yr_6hr_Chicago
2yr_3hr_Chicago INTENSITY 0:10 1 TIMESERIES 2yr_3hr_Chicago
2yr_6hr_Chicago INTENSITY 0:10 1 TIMESERIES 2yr_6hr_Chicago
50yr_3hr_Chicago INTENSITY 0:10 1 TIMESERIES 50yr_3hr_Chicago
50yr_6hr_Chicago INTENSITY 0:10 1 TIMESERIES 50yr_6hr_Chicago
5yr_3hr_Chicago INTENSITY 0:10 1 TIMESERIES 5yr_3hr_Chicago
5yr_6hr_Chicago INTENSITY 0:10 1 TIMESERIES 5yr_6hr_Chicago
Chicago_3h INTENSITY 0:05 1.0 TIMESERIES Chicago_3h
Chicago_6h100-yr INTENSITY 0:05 1.0 TIMESERIES Chicago_6h100-yr

```

```

[SUBCATCHMENTS]
;;Name Rain Gage Outlet Area %Imperv Width %
Slope CurbLen SnowPack
A-1 Chicago_6h100-yr OF1 0.0442 71.9 13
0.5 0
A-10 Chicago_6h100-yr STMH102 0.0259 88.9 14
0.5 0
A-11 Chicago_6h100-yr CB12 0.0424 85.7 12
0.5 0
A-12 Chicago_6h100-yr CB5 0.1039 72.4 22
0.5 0
A-13 Chicago_6h100-yr CB6 0.0475 96.1 17
0.5 0
A-14 Chicago_6h100-yr CB2 0.0701 78.2 22
0.5 0
A-15 Chicago_6h100-yr CB3 0.0569 79.9 17
0.5 0
A-16 Chicago_6h100-yr EXCB02 0.0646 80.6 16
0.5 0
A-17 Chicago_6h100-yr CB1 0.1424 95.1 30
0.5 0
A-18 Chicago_6h100-yr CB20 0.1522 92.3 27
0.5 0
A-19 Chicago_6h100-yr OF2 0.02 58 10
0.5 0
A-20 Chicago_6h100-yr CB4 0.0558 53.6 11
0.5 0
A-21 Chicago_6h100-yr CB8 0.0749 60.9 22
0.5 0
A-22 Chicago_6h100-yr CB13 0.0603 71.3 14
0.5 0
A-23 Chicago_6h100-yr CB07 0.0997 89.1 20
0.5 0
A-4 Chicago_6h100-yr CB15 0.1485 7.37 14
0.5 0
A-5 Chicago_6h100-yr OF2 0.0312 2.4 8.15
0.5 0
A-6 Chicago_6h100-yr Pond2 0.1023 17.4 21
0.5 0
A-7 Chicago_6h100-yr CB14 0.0589 90.8 23
0.5 0
A-8 Chicago_6h100-yr CBMH108 0.0439 96.6 15
0.5 0
A-9 Chicago_6h100-yr CB10 0.0335 100 21
0.5 0
R-1 Chicago_6h100-yr R1 0.4165 100 62
0.5 0

```

```

Swale1 VS SURFACE 0.1 0.0 0.045 1.9 3

[LID_USAGE]
;;Subcatchment LID Process Number Area Width InitSat
FromImp ToPerv RptFile DrainTo FromPerv
A-6 Swale1 1 * 40.4 6 100 0 100
0 *

[JUNCTIONS]
;;Name Elevation MaxDepth InitDepth SurDepth Aponded
CB10 76.71 1.83 0 0 0
CB7CONNECT 79.04 0.305 0 0 0
CBMH108 76.4 2.94 0 0 0
EF04 75.34 4.1 0 0 0
EF06 75.37 3.21 0 0 0
EXSTMH01 74.99 4.09 0 0 0
EXSTMH02 75.95 4.51 0 0 0
MH-ST2210 78.51 2.73 0 0 0
ROOF 76.21 0.2 0 0 0
STMH102 76.3 2.84 0 0 0
STMH106 77.85 2.9 0 0 0
STMH108 76.37 3.61 0 0 0
STMH109 76.55 3.71 0 0 0
STMH114 76.26 3.84 0 0 0

[OUTFALLS]
;;Name Elevation Type Stage Data Gated Route To
OF1 74.88 FREE NO
OF2 74.73 FREE NO

[STORAGE]
;;Name Elev. MaxDepth InitDepth Shape Curve Name/Params
N/A Fevap Psi Ksat IMD
CB07 79.26 2.29 0 TABULAR CB7
0 0
CB1 0 77.03 2.85 0 TABULAR CB1
0 0
CB12 0 76.48 3.18 0 TABULAR CB12
0 0
CB13 0 76.58 1.44 0 TABULAR CB13
0 0
CB14 0 76.66 1.78 0 TABULAR CB14
0 0
CB15 0 76.59 3 0 TABULAR CB15
0 0
CB2 0 78.19 1.7 0 TABULAR CB2
0 0
CB20 0 77.18 3.02 0 TABULAR CB20
0 0
CB3 0 78.33 2 0 TABULAR CB3
0 0
CB4 0 76.9 1.92 0 TABULAR CB4
0 0
CB5 0 78.1 2 0 TABULAR CB5
0 0

```

CB6	76.97	2.6	0	TABULAR	CB6
0					
CB8	76.65	1.65	0	TABULAR	CB8
0					
EXCB02	77.06	2.81	0	TABULAR	EXCB02
0					
MC7200	75.5	2.56	0	TABULAR	MC7200
0					
Pond1	76.13	1.77	0	TABULAR	Pond1
0					
Big Pond					
Pond2	75.81	1.99	0	TABULAR	Pond2
0					
R1	100	0.2	0	TABULAR	Rlupdate
0					

;;Name	From Node	To Node	Length	Roughness	
InOffset	OutOffset	InitFlow	MaxFlow		
C1	STMH109	STMH108	73.9	0.01	76.55
76.4	0	0			
C10	CB14	CBMH108	25.5	0.01	76.66
76.4	0	0			
C11	Pond1	Pond2	13.1	0.01	76.13
76	0	0			
C12	EFO6	EXSTMH01	13.2	0.01	75.37
75.22	0	0			
C13	CB1	STMH109	7.5	0.01	77.03
76.88	0	0			
C15	EXSTMH01	OF2	19.5	0.01	74.99
74.73	0	0			
C16	ROOF	EXSTMH02	7.8	0.01	76.21
76.05	0	0			
C17	EXSTMH02	OF1	20.8	0.01	75.95
74.91	0	0			
C19	EXCB02	STMH109	11.7	0.01	77.06
76.82	0	0			
C2	CB2	STMH108	4	0.01	78.19
78.1	0	0			
C20	CB3	STMH108	12.1	0.01	78.33
78.05	0	0			
C21	CB20	STMH109	23.8	0.01	77.18
76.88	0	0			
C22	CB4	STMH108	19.6	0.01	76.96
76.7	0	0			
C23	CB6	STMH108	5.7	0.01	76.97
76.86	0	0			
C24	CB5	STMH108	11.82	0.01	78.32
78.03	0	0			
C25	CB8	Pond1	3.1	0.01	76.65
76.62	0	0			
Small Pond					
C26	CB13	Pond1	4	0.01	75.58
75.54	0	0			
C27	CB7CONNECT	MH-ST2210	26	0.01	79.04
78.51	0	0			
C28	MH-ST2210	STMH106	14.8	0.01	78.5
77.91	0	0			
C29	STMH106	EXSTMH02	35.4	0.01	77.85
76.43	0	0			
C3	STMH108	Pond1	71.6	0.01	76.37
76.2	0	0			

C25	CIRCULAR	0.2	0	0	0
1					
C26	CIRCULAR	0.2	0	0	0
1					
C27	CIRCULAR	0.3	0	0	0
1					
C28	CIRCULAR	0.3	0	0	0
1					
C29	CIRCULAR	0.3	0	0	0
1					
C3	CIRCULAR	0.525	0	0	0
1					
C31	CIRCULAR	0.375	0	0	0
1					
C4	CIRCULAR	0.2	0	0	0
1					
C5	CIRCULAR	0.2	0	0	0
1					
C6	CIRCULAR	0.45	0	0	0
1					
C7	CIRCULAR	0.2	0	0	0
1					
C8	CIRCULAR	0.25	0	0	0
1					
C9	CIRCULAR	0.25	0	0	0
1					

;;Link Kentry Kexit Kavg Flap Gate Seepage

;;Name	Type	X-Value	Y-Value
One curb inlet at a sag			
1_CB_CI_SAG	Rating	0	0
1_CB_CI_SAG		0.018	0.002
1_CB_CI_SAG		0.03	0.01
1_CB_CI_SAG		0.04	0.018
1_CB_CI_SAG		0.05	0.03
1_CB_CI_SAG		0.06	0.05
1_CB_CI_SAG		0.07	0.08
1_CB_CI_SAG		0.1	0.093
1_CB_CI_SAG		0.2	0.097
1_CB_CI_SAG		0.3	0.1
1_CB_CI_SAG		1	0.1
1_CB_F_+1+CB_St_SAG	Rating	0	0
1_CB_F_+1+CB_St_SAG		0.05	0.018
1_CB_F_+1+CB_St_SAG		0.08	0.049
1_CB_F_+1+CB_St_SAG		0.09	0.076
1_CB_F_+1+CB_St_SAG		0.1	0.108
1_CB_F_+1+CB_St_SAG		0.104	0.117
1_CB_F_+1+CB_St_SAG		0.11	0.135
1_CB_F_+1+CB_St_SAG		0.12	0.149
1_CB_F_+1+CB_St_SAG		0.13	0.164
1_CB_F_+1+CB_St_SAG		0.14	0.1725
1_CB_F_+1+CB_St_SAG		0.15	0.18
1_CB_F_+1+CB_St_SAG		0.16	0.1855
1_CB_F_+1+CB_St_SAG		0.17	0.191
1_CB_F_+1+CB_St_SAG		0.2	0.194
1_CB_F_+1+CB_St_SAG		0.3	0.2
1_CB_F_+1+CB_St_SAG		1	0.2

C31	EFO4	EXSTMH01	11.5	0.01	75.34
75.22	0	0			
C4	CB15	STMH114	14	0.01	76.59
76.31	0	0			
C5	CB10	STMH102	15.8	0.01	76.71
76.55	0	0			
C6	STMH102	MC7200	18.3	0.01	76.3
76.21	0	0			
C7	CB12	MC7200	1.7	0.01	76.48
76.45	0	0			
C8	CBMH108	STMH114	21.4	0.01	76.4
76.29	0	0			
C9	STMH114	MC7200	5.1	0.01	76.26
76.21	0	0			

;;Name	From Node	To Node	Offset	Type
QTable/Qcoeff	Qexpon	Gated		
OL1	Pond2	EFO6	75.58	TABULAR/DEPTH
175mmplate				
OL2	CB07	CB7CONNECT	79.26	TABULAR/HEAD
125mmplate				
OL3	MC7200	EFO4	75.5	TABULAR/HEAD
HYDROVEX50VHV-1				
ROL1	R1	ROOF	100	TABULAR/HEAD
roofdrainMech				

;;Link Barrels Culvert

;;Name	Shape	Geom1	Geom2	Geom3	Geom4
C1	CIRCULAR	0.525	0	0	0
1					
C10	CIRCULAR	0.2	0	0	0
1					
C11	CIRCULAR	0.525	0	0	0
1					
C12	CIRCULAR	0.375	0	0	0
1					
C13	CIRCULAR	0.2	0	0	0
1					
C15	CIRCULAR	0.61	0	0	0
1					
C16	CIRCULAR	0.2	0	0	0
1					
C17	CIRCULAR	0.305	0	0	0
1					
C19	CIRCULAR	0.2	0	0	0
1					
C2	CIRCULAR	0.2	0	0	0
1					
C20	CIRCULAR	0.2	0	0	0
1					
C21	CIRCULAR	0.2	0	0	0
1					
C22	CIRCULAR	0.2	0	0	0
1					
C23	CIRCULAR	0.2	0	0	0
1					
C24	CIRCULAR	0.2	0	0	0
1					

1_CB_F_SAG	Rating	0	0
1_CB_F_SAG		0.05	0.01
1_CB_F_SAG		0.08	0.027
1_CB_F_SAG		0.09	0.042
1_CB_F_SAG		0.1	0.06
1_CB_F_SAG		0.104	0.065
1_CB_F_SAG		0.11	0.075
1_CB_F_SAG		0.12	0.082
1_CB_F_SAG		0.13	0.09
1_CB_F_SAG		0.15	0.095
1_CB_F_SAG		0.2	0.097
1_CB_F_SAG		0.3	0.1
1_CB_F_SAG		1	0.1

1_CB_F_Slope	Rating	0	0
1_CB_F_Slope		0.01	0.001
1_CB_F_Slope		0.015	0.003
1_CB_F_Slope		0.021	0.007
1_CB_F_Slope		0.03	0.014
1_CB_F_Slope		0.04	0.024
1_CB_F_Slope		0.05	0.036
1_CB_F_Slope		0.054	0.041
1_CB_F_Slope		0.06	0.047
1_CB_F_Slope		0.07	0.05
1_CB_F_Slope		1	0.05

1_CB_St_Sag	Rating	0	0
1_CB_St_Sag		0.05	0.008
1_CB_St_Sag		0.08	0.022
1_CB_St_Sag		0.09	0.034
1_CB_St_Sag		0.1	0.048
1_CB_St_Sag		0.104	0.052
1_CB_St_Sag		0.11	0.06
1_CB_St_Sag		0.14	0.08
1_CB_St_Sag		0.15	0.085
1_CB_St_Sag		0.16	0.09
1_CB_St_Sag		0.17	0.095
1_CB_St_Sag		0.2	0.097
1_CB_St_Sag		0.3	0.1
1_CB_St_Sag		1	0.1

1_CB_St_Slope	Rating	0	0
1_CB_St_Slope		0.01	0.001
1_CB_St_Slope		0.015	0.003
1_CB_St_Slope		0.021	0.006
1_CB_St_Slope		0.03	0.012
1_CB_St_Slope		0.04	0.02
1_CB_St_Slope		0.054	0.034
1_CB_St_Slope		0.06	0.04
1_CB_St_Slope		0.08	0.05
1_CB_St_Slope		1	0.05

1_CB_St_Slope_3_CB_F_Sag	Rating	0	0
1_CB_St_Slope_3_CB_F_Sag		0.01	0.007
1_CB_St_Slope_3_CB_F_Sag		0.015	0.012
1_CB_St_Slope_3_CB_F_Sag		0.021	0.0186
1_CB_St_Slope_3_CB_F_Sag		0.03	0.03
1_CB_St_Slope_3_CB_F_Sag		0.04	0.044
1_CB_St_Slope_3_CB_F_Sag		0.05	0.06
1_CB_St_Slope_3_CB_F_Sag		0.054	0.0708

1_CB_St_Slope_3_CB_F_Sag	0.06	0.087
1_CB_St_Slope_3_CB_F_Sag	0.08	0.131
1_CB_St_Slope_3_CB_F_Sag	0.09	0.176
1_CB_St_Slope_3_CB_F_Sag	0.1	0.23
1_CB_St_Slope_3_CB_F_Sag	0.104	0.245
1_CB_St_Slope_3_CB_F_Sag	0.11	0.275
1_CB_St_Slope_3_CB_F_Sag	0.12	0.296
1_CB_St_Slope_3_CB_F_Sag	0.13	0.32
1_CB_St_Slope_3_CB_F_Sag	0.15	0.335
1_CB_St_Slope_3_CB_F_Sag	0.2	0.341
1_CB_St_Slope_3_CB_F_Sag	0.3	0.35
1_CB_St_Slope_3_CB_F_Sag	1	0.35
10_CB_F_Sag	Rating	0
10_CB_F_Sag	0.05	0.1
10_CB_F_Sag	0.08	0.27
10_CB_F_Sag	0.09	0.42
10_CB_F_Sag	0.1	0.6
10_CB_F_Sag	0.104	0.65
10_CB_F_Sag	0.11	0.75
10_CB_F_Sag	0.12	0.82
10_CB_F_Sag	0.13	0.9
10_CB_F_Sag	0.15	0.95
10_CB_F_Sag	0.2	0.97
10_CB_F_Sag	0.3	1
10_CB_F_Sag	1	1
10_CB_F_Slope	Rating	0
10_CB_F_Slope	0.01	0.01
10_CB_F_Slope	0.015	0.03
10_CB_F_Slope	0.021	0.07
10_CB_F_Slope	0.03	0.14
10_CB_F_Slope	0.04	0.24
10_CB_F_Slope	0.05	0.36
10_CB_F_Slope	0.054	0.41
10_CB_F_Slope	0.06	0.47
10_CB_F_Slope	0.07	0.5
10_CB_F_Slope	1	0.5
10_CB_St_Sag	Rating	0
10_CB_St_Sag	0.05	0.08
10_CB_St_Sag	0.08	0.22
10_CB_St_Sag	0.09	0.34
10_CB_St_Sag	0.1	0.48
10_CB_St_Sag	0.104	0.52
10_CB_St_Sag	0.11	0.6
10_CB_St_Sag	0.14	0.8
10_CB_St_Sag	0.15	0.85
10_CB_St_Sag	0.16	0.9
10_CB_St_Sag	0.17	0.95
10_CB_St_Sag	0.2	0.97
10_CB_St_Sag	0.3	1
10_CB_St_Sag	1	1
100mmPlate	Rating	0
100mmPlate	0.25	0.01095847
100mmPlate	0.5	0.015497617
100mmPlate	0.75	0.018980627
100mmPlate	1	0.021916941
100mmPlate	1.25	0.024503885
100mmPlate	1.5	0.026842661
100mmPlate	1.75	0.028993387

14_CB_F_Slope	Rating	0
14_CB_F_Slope	0.01	0.014
14_CB_F_Slope	0.015	0.042
14_CB_F_Slope	0.021	0.098
14_CB_F_Slope	0.03	0.196
14_CB_F_Slope	0.04	0.336
14_CB_F_Slope	0.05	0.504
14_CB_F_Slope	0.054	0.574
14_CB_F_Slope	0.06	0.658
14_CB_F_Slope	0.07	0.7
14_CB_F_Slope	1	0.7
15_CB_F_Slope	Rating	0
15_CB_F_Slope	0.01	0.015
15_CB_F_Slope	0.015	0.045
15_CB_F_Slope	0.021	0.105
15_CB_F_Slope	0.03	0.21
15_CB_F_Slope	0.04	0.36
15_CB_F_Slope	0.05	0.54
15_CB_F_Slope	0.054	0.635
15_CB_F_Slope	0.06	0.705
15_CB_F_Slope	0.07	0.75
15_CB_F_Slope	1	0.75
150mmPlate	Rating	0
150mmPlate	0.25	0.024656558
150mmPlate	0.5	0.034869639
150mmPlate	0.75	0.042706412
150mmPlate	1	0.049331117
150mmPlate	1.25	0.05513374
150mmPlate	1.5	0.060395987
150mmPlate	1.75	0.065235121
150mmPlate	2	0.069739278
150mmPlate	2.25	0.073969675
150mmPlate	2.5	0.077970883
150mmPlate	2.75	0.081776552
150mmPlate	3	0.085412823
150mmPlate	3.25	0.088900485
150mmPlate	3.5	0.092256393
150mmPlate	3.75	0.09549444
150mmPlate	4	0.098626233
150mmPlate	4.25	0.101661594
150mmPlate	4.5	0.104608917
150mmPlate	4.75	0.107475446
150mmPlate	5	0.110267481
175mmPlate	Rating	0
175mmPlate	0.25	0.026627712
175mmPlate	0.5	0.042424736
175mmPlate	0.75	0.053749057
175mmPlate	1	0.063099164
175mmPlate	1.25	0.071220276
175mmPlate	1.5	0.078505738
175mmPlate	1.75	0.085170265
175mmPlate	2	0.091349861
175mmPlate	2.25	0.097137121
175mmPlate	2.5	0.102598457
175mmPlate	2.75	0.107783425
175mmPlate	3	0.112730163
175mmPlate	3.25	0.117468774
175mmPlate	3.5	0.122023506

100mmPlate	2	0.030995235
100mmPlate	2.25	0.032875411
100mmPlate	2.5	0.034653726
100mmPlate	2.75	0.036345134
100mmPlate	3	0.037961255
100mmPlate	3.25	0.039511327
100mmPlate	3.5	0.041002842
100mmPlate	3.75	0.042441973
100mmPlate	4	0.04383081
100mmPlate	4.25	0.045182931
100mmPlate	4.5	0.046492852
100mmPlate	4.75	0.047766865
100mmPlate	5	0.049007769
11_CB_St_Slope	Rating	0
11_CB_St_Slope	0.01	0.011
11_CB_St_Slope	0.015	0.033
11_CB_St_Slope	0.021	0.066
11_CB_St_Slope	0.03	0.132
11_CB_St_Slope	0.04	0.22
11_CB_St_Slope	0.05	0.33
11_CB_St_Slope	0.054	0.374
11_CB_St_Slope	0.06	0.44
11_CB_St_Slope	0.08	0.55
11_CB_St_Slope	1	0.55
125mmplate	Rating	0
125mmplate	0.25	0.01712261
125mmplate	0.5	0.024215027
125mmplate	0.75	0.02965723
125mmplate	1	0.03424522
125mmplate	1.25	0.03828732
125mmplate	1.5	0.041941657
125mmplate	1.75	0.045302168
125mmplate	2	0.048430054
125mmplate	2.25	0.05136783
125mmplate	2.5	0.054146447
125mmplate	2.75	0.056789273
125mmplate	3	0.059314461
125mmplate	3.25	0.061736448
125mmplate	3.5	0.06406694
125mmplate	3.75	0.066315583
125mmplate	4	0.06849044
125mmplate	4.25	0.070598329
125mmplate	4.5	0.072645081
125mmplate	4.75	0.074635726
125mmplate	5	0.076574639
13_CB_St_Sag	Rating	0
13_CB_St_Sag	0.05	0.104
13_CB_St_Sag	0.08	0.286
13_CB_St_Sag	0.09	0.442
13_CB_St_Sag	0.1	0.624
13_CB_St_Sag	0.104	0.676
13_CB_St_Sag	0.11	0.78
13_CB_St_Sag	0.14	1.04
13_CB_St_Sag	0.15	1.105
13_CB_St_Sag	0.16	1.17
13_CB_St_Sag	0.17	1.235
13_CB_St_Sag	0.2	1.261
13_CB_St_Sag	0.3	1.3
13_CB_St_Sag	1	1.3

175mmplate	3.75	0.126414237
175mmplate	4	0.1306575
1CB_F+ICB_St_SLOPE	Rating	0
1CB_F+ICB_St_SLOPE	0.01	0.002
1CB_F+ICB_St_SLOPE	0.015	0.006
1CB_F+ICB_St_SLOPE	0.021	0.013
1CB_F+ICB_St_SLOPE	0.03	0.026
1CB_F+ICB_St_SLOPE	0.04	0.044
1CB_F+ICB_St_SLOPE	0.05	0.066
1CB_F+ICB_St_SLOPE	0.054	0.075
1CB_F+ICB_St_SLOPE	0.06	0.087
1CB_F+ICB_St_SLOPE	0.07	0.095
1CB_F+ICB_St_SLOPE	0.08	0.1
1CB_F+ICB_St_SLOPE	1	0.1
;2 curb inlet CBs at sag		
2_CB_CI_Sag	Rating	0
2_CB_CI_Sag	0.018	0.004
2_CB_CI_Sag	0.03	0.02
2_CB_CI_Sag	0.04	0.036
2_CB_CI_Sag	0.05	0.06
2_CB_CI_Sag	0.06	0.1
2_CB_CI_Sag	0.07	0.16
2_CB_CI_Sag	0.1	0.186
2_CB_CI_Sag	0.2	0.194
2_CB_CI_Sag	0.3	0.2
2_CB_CI_Sag	1	0.2
;2 curb inlets on slope		
2_CB_CI_SLOPE	Rating	0
2_CB_CI_SLOPE	0.01	0.002
2_CB_CI_SLOPE	0.015	0.004
2_CB_CI_SLOPE	0.021	0.008
2_CB_CI_SLOPE	0.03	0.012
2_CB_CI_SLOPE	0.04	0.018
2_CB_CI_SLOPE	0.05	0.026
2_CB_CI_SLOPE	0.054	0.028
2_CB_CI_SLOPE	0.06	0.034
2_CB_CI_SLOPE	0.07	0.042
2_CB_CI_SLOPE	0.08	0.052
2_CB_CI_SLOPE	0.09	0.062
2_CB_CI_SLOPE	0.14	0.1
2_CB_CI_SLOPE	1	0.1
;2 fish CBs and 2 curb inlet cbs on slope		
2_CB_f+2_CB_CI_Slope	Rating	0
2_CB_f+2_CB_CI_Slope	0.01	0.004
2_CB_f+2_CB_CI_Slope	0.015	0.01
2_CB_f+2_CB_CI_Slope	0.021	0.022
2_CB_f+2_CB_CI_Slope	0.03	0.04
2_CB_f+2_CB_CI_Slope	0.04	0.066
2_CB_f+2_CB_CI_Slope	0.05	0.098
2_CB_f+2_CB_CI_Slope	0.054	0.11
2_CB_f+2_CB_CI_Slope	0.06	0.128
2_CB_f+2_CB_CI_Slope	0.07	0.142
2_CB_f+2_CB_CI_Slope	0.08	0.152
2_CB_f+2_CB_CI_Slope	0.09	0.162
2_CB_f+2_CB_CI_Slope	0.14	0.2
2_CB_f+2_CB_CI_Slope	1	0.2
2_CB_F_SAG	Rating	0
2_CB_F_SAG	0	0

2_CB_F_SAG	0.05	0.02
2_CB_F_SAG	0.08	0.054
2_CB_F_SAG	0.09	0.084
2_CB_F_SAG	0.1	0.12
2_CB_F_SAG	0.104	0.13
2_CB_F_SAG	0.11	0.15
2_CB_F_SAG	0.12	0.164
2_CB_F_SAG	0.13	0.18
2_CB_F_SAG	0.15	0.19
2_CB_F_SAG	0.2	0.194
2_CB_F_SAG	0.3	0.2
2_CB_F_SAG	1	0.2
2_CB_F_SLOPE	Rating	0
2_CB_F_SLOPE	0.01	0.002
2_CB_F_SLOPE	0.015	0.006
2_CB_F_SLOPE	0.021	0.014
2_CB_F_SLOPE	0.03	0.028
2_CB_F_SLOPE	0.04	0.048
2_CB_F_SLOPE	0.05	0.072
2_CB_F_SLOPE	0.054	0.082
2_CB_F_SLOPE	0.06	0.094
2_CB_F_SLOPE	0.07	0.1
2_CB_F_SLOPE	1	0.1
2_CB_St_1_CB_F_Slope	Rating	0
2_CB_St_1_CB_F_Slope	0.01	0.003
2_CB_St_1_CB_F_Slope	0.015	0.009
2_CB_St_1_CB_F_Slope	0.021	0.019
2_CB_St_1_CB_F_Slope	0.03	0.038
2_CB_St_1_CB_F_Slope	0.04	0.064
2_CB_St_1_CB_F_Slope	0.05	0.096
2_CB_St_1_CB_F_Slope	0.054	0.109
2_CB_St_1_CB_F_Slope	0.06	0.127
2_CB_St_1_CB_F_Slope	0.07	0.14
2_CB_St_1_CB_F_Slope	0.08	0.15
2_CB_St_1_CB_F_Slope	1	0.15
2_CB_St_Sag	Rating	0
2_CB_St_Sag	0.05	0.016
2_CB_St_Sag	0.08	0.044
2_CB_St_Sag	0.09	0.068
2_CB_St_Sag	0.1	0.096
2_CB_St_Sag	0.104	0.104
2_CB_St_Sag	0.11	0.12
2_CB_St_Sag	0.14	0.16
2_CB_St_Sag	0.15	0.17
2_CB_St_Sag	0.16	0.18
2_CB_St_Sag	0.17	0.19
2_CB_St_Sag	0.2	0.194
2_CB_St_Sag	0.3	0.2
2_CB_St_Sag	1	0.2
2_CB_St_Slope	Rating	0
2_CB_St_Slope	0.01	0.002
2_CB_St_Slope	0.015	0.006
2_CB_St_Slope	0.021	0.012
2_CB_St_Slope	0.03	0.024
2_CB_St_Slope	0.04	0.04
2_CB_St_Slope	0.05	0.06
2_CB_St_Slope	0.054	0.068
2_CB_St_Slope	0.06	0.08

2_CB_St_Slope	0.08	0.1
2_CB_St_Slope	1	0.1
200mmPlate	Rating	0
200mmPlate	0.25	0.043833881
200mmPlate	0.5	0.06199047
200mmPlate	0.75	0.07592251
200mmPlate	1	0.087667763
200mmPlate	1.25	0.098015538
200mmPlate	1.5	0.107370643
200mmPlate	1.75	0.115973549
200mmPlate	2	0.123980939
200mmPlate	2.25	0.131501644
200mmPlate	2.5	0.138614904
200mmPlate	2.75	0.145380538
200mmPlate	3	0.151845019
200mmPlate	3.25	0.158045307
200mmPlate	3.5	0.164011366
200mmPlate	3.75	0.169767893
200mmPlate	4	0.17533526
200mmPlate	4.25	0.180731723
200mmPlate	4.5	0.185971409
200mmPlate	4.75	0.191067459
200mmPlate	5	0.196031077
225mmPlate	Rating	0
225mmPlate	0.25	0.055477256
225mmPlate	0.5	0.078456688
225mmPlate	0.75	0.096089426
225mmPlate	1	0.110954512
225mmPlate	1.25	0.124050916
225mmPlate	1.5	0.13589097
225mmPlate	1.75	0.146779023
225mmPlate	2	0.156913376
225mmPlate	2.25	0.166431768
225mmPlate	2.5	0.175434488
225mmPlate	2.75	0.183997243
225mmPlate	3	0.192178853
225mmPlate	3.25	0.20026092
225mmPlate	3.5	0.207576885
225mmPlate	3.75	0.214862489
225mmPlate	4	0.221909024
225mmPlate	4.25	0.228738587
225mmPlate	4.5	0.235370064
225mmPlate	4.75	0.241819753
225mmPlate	5	0.248101832
2CB_F+1CB_St_SAG	Rating	0
2CB_F+1CB_St_SAG	0.05	0.028
2CB_F+1CB_St_SAG	0.08	0.076
2CB_F+1CB_St_SAG	0.09	0.118
2CB_F+1CB_St_SAG	0.1	0.168
2CB_F+1CB_St_SAG	0.104	0.182
2CB_F+1CB_St_SAG	0.11	0.21
2CB_F+1CB_St_SAG	0.12	0.231
2CB_F+1CB_St_SAG	0.13	0.254
2CB_F+1CB_St_SAG	0.14	0.265
2CB_F+1CB_St_SAG	0.15	0.275
2CB_F+1CB_St_SAG	0.16	0.281
2CB_F+1CB_St_SAG	0.17	0.287
2CB_F+1CB_St_SAG	0.2	0.291
2CB_F+1CB_St_SAG	0.3	0.3

2CB_F+1CB_St_SAG	1	0.3
2CB_F+2CB_St_SAG	Rating	0
2CB_F+2CB_St_SAG	0.05	0.036
2CB_F+2CB_St_SAG	0.08	0.098
2CB_F+2CB_St_SAG	0.09	0.152
2CB_F+2CB_St_SAG	0.1	0.216
2CB_F+2CB_St_SAG	0.104	0.234
2CB_F+2CB_St_SAG	0.11	0.27
2CB_F+2CB_St_SAG	0.12	0.298
2CB_F+2CB_St_SAG	0.13	0.328
2CB_F+2CB_St_SAG	0.14	0.345
2CB_F+2CB_St_SAG	0.15	0.36
2CB_F+2CB_St_SAG	0.16	0.371
2CB_F+2CB_St_SAG	0.17	0.382
2CB_F+2CB_St_SAG	0.2	0.388
2CB_F+2CB_St_SAG	0.3	0.4
2CB_F+2CB_St_SAG	1	0.4
3 CB CI at sag	Rating	0
3_CB_CI_SAG	0.018	0.006
3_CB_CI_SAG	0.03	0.03
3_CB_CI_SAG	0.04	0.054
3_CB_CI_SAG	0.05	0.09
3_CB_CI_SAG	0.06	0.15
3_CB_CI_SAG	0.07	0.24
3_CB_CI_SAG	0.1	0.279
3_CB_CI_SAG	0.2	0.291
3_CB_CI_SAG	0.3	0.3
3_CB_CI_SAG	1	0.3
3 curb inlet CBs on slope	Rating	0
3_CB_CI_Slope	0.01	0.003
3_CB_CI_Slope	0.015	0.006
3_CB_CI_Slope	0.021	0.012
3_CB_CI_Slope	0.03	0.018
3_CB_CI_Slope	0.04	0.027
3_CB_CI_Slope	0.05	0.039
3_CB_CI_Slope	0.06	0.042
3_CB_CI_Slope	0.07	0.051
3_CB_CI_Slope	0.08	0.063
3_CB_CI_Slope	0.09	0.078
3_CB_CI_Slope	0.14	0.15
3_CB_CI_Slope	1	0.15
3_CB_F_SAG	Rating	0
3_CB_F_SAG	0.05	0.03
3_CB_F_SAG	0.08	0.081
3_CB_F_SAG	0.09	0.126
3_CB_F_SAG	0.1	0.18
3_CB_F_SAG	0.104	0.195
3_CB_F_SAG	0.11	0.225
3_CB_F_SAG	0.12	0.246
3_CB_F_SAG	0.13	0.27
3_CB_F_SAG	0.15	0.285
3_CB_F_SAG	0.2	0.291
3_CB_F_SAG	0.3	0.3
3_CB_F_SAG	1	0.3

3_CB_F_SLOPE	Rating	0
3_CB_F_SLOPE	0.01	0.003
3_CB_F_SLOPE	0.015	0.009
3_CB_F_SLOPE	0.021	0.021
3_CB_F_SLOPE	0.03	0.042
3_CB_F_SLOPE	0.04	0.072
3_CB_F_SLOPE	0.05	0.108
3_CB_F_SLOPE	0.054	0.123
3_CB_F_SLOPE	0.06	0.141
3_CB_F_SLOPE	0.07	0.15
3_CB_F_SLOPE	1	0.15
3_CB_St_Sag	Rating	0
3_CB_St_Sag	0.05	0.024
3_CB_St_Sag	0.08	0.066
3_CB_St_Sag	0.09	0.102
3_CB_St_Sag	0.1	0.144
3_CB_St_Sag	0.104	0.156
3_CB_St_Sag	0.11	0.18
3_CB_St_Sag	0.14	0.24
3_CB_St_Sag	0.15	0.255
3_CB_St_Sag	0.16	0.27
3_CB_St_Sag	0.17	0.285
3_CB_St_Sag	0.2	0.291
3_CB_St_Sag	0.3	0.3
3_CB_St_Sag	1	0.3
3_CB_T_Slope	Rating	0
3_CB_T_Slope	0.01	0.003
3_CB_T_Slope	0.015	0.009
3_CB_T_Slope	0.021	0.018
3_CB_T_Slope	0.03	0.036
3_CB_T_Slope	0.04	0.06
3_CB_T_Slope	0.05	0.09
3_CB_T_Slope	0.054	0.102
3_CB_T_Slope	0.06	0.12
3_CB_T_Slope	0.08	0.15
3_CB_T_Slope	1	0.15
4 curb inlet at sag	Rating	0
4_CB_CI_SAG	0.018	0.008
4_CB_CI_SAG	0.03	0.04
4_CB_CI_SAG	0.04	0.072
4_CB_CI_SAG	0.05	0.12
4_CB_CI_SAG	0.06	0.2
4_CB_CI_SAG	0.07	0.32
4_CB_CI_SAG	0.1	0.372
4_CB_CI_SAG	0.2	0.388
4_CB_CI_SAG	0.3	0.4
4_CB_CI_SAG	1	0.4
4 curb inlet CBs on slope	Rating	0
4_CB_CI_Slope	0.01	0.004
4_CB_CI_Slope	0.015	0.008
4_CB_CI_Slope	0.021	0.016
4_CB_CI_Slope	0.03	0.024
4_CB_CI_Slope	0.04	0.036
4_CB_CI_Slope	0.05	0.052
4_CB_CI_Slope	0.054	0.056
4_CB_CI_Slope	0.06	0.068

4_CB_CI_Slope	0.07	0.084
4_CB_CI_Slope	0.08	0.104
4_CB_CI_Slope	0.09	0.124
4_CB_CI_Slope	0.14	0.2
4_CB_CI_Slope	1	0.2
4_CB_F_Sag	Rating	0
4_CB_F_Sag	0.05	0.04
4_CB_F_Sag	0.08	0.108
4_CB_F_Sag	0.09	0.168
4_CB_F_Sag	0.1	0.24
4_CB_F_Sag	0.104	0.26
4_CB_F_Sag	0.11	0.3
4_CB_F_Sag	0.12	0.328
4_CB_F_Sag	0.13	0.36
4_CB_F_Sag	0.15	0.38
4_CB_F_Sag	0.2	0.388
4_CB_F_Sag	0.3	0.4
4_CB_F_Sag	1	0.4
4_CB_F_Slope	Rating	0
4_CB_F_Slope	0.01	0.004
4_CB_F_Slope	0.015	0.012
4_CB_F_Slope	0.021	0.028
4_CB_F_Slope	0.03	0.056
4_CB_F_Slope	0.04	0.096
4_CB_F_Slope	0.05	0.144
4_CB_F_Slope	0.054	0.164
4_CB_F_Slope	0.06	0.188
4_CB_F_Slope	0.07	0.2
4_CB_F_Slope	1	0.2
4_CB_St_Sag	Rating	0
4_CB_St_Sag	0.05	0.032
4_CB_St_Sag	0.08	0.088
4_CB_St_Sag	0.09	0.136
4_CB_St_Sag	0.1	0.192
4_CB_St_Sag	0.104	0.208
4_CB_St_Sag	0.11	0.24
4_CB_St_Sag	0.14	0.32
4_CB_St_Sag	0.15	0.34
4_CB_St_Sag	0.16	0.36
4_CB_St_Sag	0.17	0.38
4_CB_St_Sag	0.2	0.388
4_CB_St_Sag	0.3	0.4
4_CB_St_Sag	1	0.4
4_CB_St_Slope	Rating	0
4_CB_St_Slope	0.01	0.004
4_CB_St_Slope	0.015	0.012
4_CB_St_Slope	0.021	0.024
4_CB_St_Slope	0.03	0.048
4_CB_St_Slope	0.04	0.08
4_CB_St_Slope	0.05	0.12
4_CB_St_Slope	0.054	0.136
4_CB_St_Slope	0.06	0.16
4_CB_St_Slope	0.08	0.2
4_CB_St_Slope	1	0.2
5_CB_F_Sag	Rating	0
5_CB_F_Sag	0.05	0.05
5_CB_F_Sag	0.08	0.135

5_CB_F_Sag	0.09	0.21
5_CB_F_Sag	0.1	0.3
5_CB_F_Sag	0.104	0.325
5_CB_F_Sag	0.11	0.375
5_CB_F_Sag	0.12	0.41
5_CB_F_Sag	0.13	0.45
5_CB_F_Sag	0.15	0.475
5_CB_F_Sag	0.2	0.485
5_CB_F_Sag	0.3	0.5
5_CB_F_Sag	1	0.5
5_CB_St_Sag	Rating	0
5_CB_St_Sag	0.05	0.04
5_CB_St_Sag	0.08	0.11
5_CB_St_Sag	0.09	0.17
5_CB_St_Sag	0.1	0.24
5_CB_St_Sag	0.104	0.26
5_CB_St_Sag	0.11	0.3
5_CB_St_Sag	0.14	0.4
5_CB_St_Sag	0.15	0.425
5_CB_St_Sag	0.16	0.45
5_CB_St_Sag	0.17	0.475
5_CB_St_Sag	0.2	0.485
5_CB_St_Sag	0.3	0.5
5_CB_St_Sag	1	0.5
5_CB_St_Slope	Rating	0
5_CB_St_Slope	0.01	0.005
5_CB_St_Slope	0.015	0.015
5_CB_St_Slope	0.021	0.03
5_CB_St_Slope	0.03	0.06
5_CB_St_Slope	0.04	0.1
5_CB_St_Slope	0.05	0.15
5_CB_St_Slope	0.054	0.17
5_CB_St_Slope	0.06	0.2
5_CB_St_Slope	0.08	0.25
5_CB_St_Slope	1	0.25
5CB_St_Slope_2_CB_F_Sag	Rating	0
5CB_St_Slope_2_CB_F_Sag	0.01	0.009
5CB_St_Slope_2_CB_F_Sag	0.015	0.021
5CB_St_Slope_2_CB_F_Sag	0.021	0.0384
5CB_St_Slope_2_CB_F_Sag	0.03	0.072
5CB_St_Slope_2_CB_F_Sag	0.04	0.116
5CB_St_Slope_2_CB_F_Sag	0.05	0.17
5CB_St_Slope_2_CB_F_Sag	0.054	0.1945333333
5CB_St_Slope_2_CB_F_Sag	0.06	0.2313333333
5CB_St_Slope_2_CB_F_Sag	0.08	0.304
5CB_St_Slope_2_CB_F_Sag	0.09	0.334
5CB_St_Slope_2_CB_F_Sag	0.1	0.37
5CB_St_Slope_2_CB_F_Sag	0.104	0.38
5CB_St_Slope_2_CB_F_Sag	0.11	0.4
5CB_St_Slope_2_CB_F_Sag	0.12	0.414
5CB_St_Slope_2_CB_F_Sag	0.13	0.43
5CB_St_Slope_2_CB_F_Sag	0.15	0.44
5CB_St_Slope_2_CB_F_Sag	0.2	0.444
5CB_St_Slope_2_CB_F_Sag	0.3	0.45
5CB_St_Slope_2_CB_F_Sag	1	0.45
6_CB_F_Sag	Rating	0
6_CB_F_Sag	0.05	0.06
6_CB_F_Sag	0.08	0.162

6_CB_F_Sag	0.09	0.252
6_CB_F_Sag	0.1	0.36
6_CB_F_Sag	0.104	0.39
6_CB_F_Sag	0.11	0.45
6_CB_F_Sag	0.12	0.492
6_CB_F_Sag	0.13	0.54
6_CB_F_Sag	0.15	0.57
6_CB_F_Sag	0.2	0.582
6_CB_F_Sag	0.3	0.6
6_CB_F_Sag	1	0.6
6_CB_F_SLOPE	Rating	0
6_CB_F_SLOPE	0.01	0.006
6_CB_F_SLOPE	0.015	0.018
6_CB_F_SLOPE	0.021	0.042
6_CB_F_SLOPE	0.03	0.084
6_CB_F_SLOPE	0.04	0.144
6_CB_F_SLOPE	0.05	0.216
6_CB_F_SLOPE	0.054	0.246
6_CB_F_SLOPE	0.06	0.282
6_CB_F_SLOPE	0.07	0.3
6_CB_F_SLOPE	1	0.3
6_CB_St_Sag	Rating	0
6_CB_St_Sag	0.05	0.048
6_CB_St_Sag	0.08	0.132
6_CB_St_Sag	0.09	0.204
6_CB_St_Sag	0.1	0.288
6_CB_St_Sag	0.104	0.312
6_CB_St_Sag	0.11	0.36
6_CB_St_Sag	0.14	0.48
6_CB_St_Sag	0.15	0.51
6_CB_St_Sag	0.16	0.54
6_CB_St_Sag	0.17	0.57
6_CB_St_Sag	0.2	0.582
6_CB_St_Sag	0.3	0.6
6_CB_St_Sag	1	0.6
6_CB_St_Slope	Rating	0
6_CB_St_Slope	0.01	0.006
6_CB_St_Slope	0.015	0.018
6_CB_St_Slope	0.021	0.036
6_CB_St_Slope	0.03	0.072
6_CB_St_Slope	0.04	0.12
6_CB_St_Slope	0.05	0.18
6_CB_St_Slope	0.054	0.204
6_CB_St_Slope	0.06	0.24
6_CB_St_Slope	0.08	0.3
6_CB_St_Slope	1	0.3
7_CB_St_Sag	Rating	0
7_CB_St_Sag	0.05	0.056
7_CB_St_Sag	0.08	0.154
7_CB_St_Sag	0.09	0.238
7_CB_St_Sag	0.1	0.336
7_CB_St_Sag	0.104	0.364
7_CB_St_Sag	0.11	0.42
7_CB_St_Sag	0.14	0.56
7_CB_St_Sag	0.15	0.595
7_CB_St_Sag	0.16	0.63
7_CB_St_Sag	0.17	0.665
7_CB_St_Sag	0.2	0.679

7_CB_St_Sag	0.3	0.7
7_CB_St_Sag	1	0.7
7_CB_St_Slope	Rating	0
7_CB_St_Slope	0.01	0.007
7_CB_St_Slope	0.015	0.021
7_CB_St_Slope	0.021	0.042
7_CB_St_Slope	0.03	0.084
7_CB_St_Slope	0.04	0.14
7_CB_St_Slope	0.05	0.21
7_CB_St_Slope	0.054	0.238
7_CB_St_Slope	0.06	0.28
7_CB_St_Slope	0.08	0.35
7_CB_St_Slope	1	0.35
75mmPlate	Rating	0
75mmPlate	0.25	0.00616414
75mmPlate	0.5	0.00871741
75mmPlate	0.75	0.010676603
75mmPlate	1	0.01228279
75mmPlate	1.25	0.013783435
75mmPlate	1.5	0.015098997
75mmPlate	1.75	0.01630878
75mmPlate	2	0.01743482
75mmPlate	2.25	0.018492419
75mmPlate	2.5	0.019492721
75mmPlate	2.75	0.020444138
75mmPlate	3	0.021353206
75mmPlate	3.25	0.022225121
75mmPlate	3.5	0.023064098
75mmPlate	3.75	0.02387361
75mmPlate	4	0.024656558
75mmPlate	4.25	0.025415399
75mmPlate	4.5	0.026152229
75mmPlate	4.75	0.026868861
75mmPlate	5	0.02756687
7CBST_slope_6_CBSTsag	Rating	0
7CBST_slope_6_CBSTsag	0.01	0.0166
7CBST_slope_6_CBSTsag	0.015	0.0354
7CBST_slope_6_CBSTsag	0.021	0.06216
7CBST_slope_6_CBSTsag	0.03	0.1128
7CBST_slope_6_CBSTsag	0.04	0.1784
7CBST_slope_6_CBSTsag	0.05	0.258
7CBST_slope_6_CBSTsag	0.054	0.2972
7CBST_slope_6_CBSTsag	0.06	0.356
7CBST_slope_6_CBSTsag	0.08	0.482
7CBST_slope_6_CBSTsag	0.09	0.554
7CBST_slope_6_CBSTsag	0.1	0.638
7CBST_slope_6_CBSTsag	0.104	0.662
7CBST_slope_6_CBSTsag	0.11	0.71
7CBST_slope_6_CBSTsag	0.14	0.83
7CBST_slope_6_CBSTsag	0.15	0.86
7CBST_slope_6_CBSTsag	0.16	0.89
7CBST_slope_6_CBSTsag	0.17	0.92
7CBST_slope_6_CBSTsag	0.2	0.932
7CBST_slope_6_CBSTsag	0.3	0.95
7CBST_slope_6_CBSTsag	1	0.95
8_CB_F_SAG	Rating	0
8_CB_F_SAG	0.05	0.08
8_CB_F_SAG	0.08	0.216

8_CB_F_SAG	0.09	0.336
8_CB_F_SAG	0.1	0.48
8_CB_F_SAG	0.104	0.52
8_CB_F_SAG	0.11	0.6
8_CB_F_SAG	0.12	0.656
8_CB_F_SAG	0.13	0.72
8_CB_F_SAG	0.15	0.76
8_CB_F_SAG	0.2	0.776
8_CB_F_SAG	0.3	0.8
8_CB_F_SAG	1	0.8
8_CB_St_Sag	Rating	0
8_CB_St_Sag	0.05	0.064
8_CB_St_Sag	0.08	0.176
8_CB_St_Sag	0.09	0.272
8_CB_St_Sag	0.1	0.384
8_CB_St_Sag	0.104	0.416
8_CB_St_Sag	0.11	0.48
8_CB_St_Sag	0.14	0.64
8_CB_St_Sag	0.15	0.68
8_CB_St_Sag	0.16	0.72
8_CB_St_Sag	0.17	0.76
8_CB_St_Sag	0.2	0.776
8_CB_St_Sag	0.3	0.8
8_CB_St_Sag	1	0.8
8_CB_St_Slope	Rating	0
8_CB_St_Slope	0.01	0.008
8_CB_St_Slope	0.015	0.024
8_CB_St_Slope	0.021	0.048
8_CB_St_Slope	0.03	0.096
8_CB_St_Slope	0.04	0.16
8_CB_St_Slope	0.05	0.24
8_CB_St_Slope	0.054	0.272
8_CB_St_Slope	0.06	0.32
8_CB_St_Slope	0.08	0.4
8_CB_St_Slope	1	0.4
9_CB_F_Slope	Rating	0
9_CB_F_Slope	0.01	0.009
9_CB_F_Slope	0.015	0.027
9_CB_F_Slope	0.021	0.063
9_CB_F_Slope	0.03	0.126
9_CB_F_Slope	0.04	0.216
9_CB_F_Slope	0.05	0.324
9_CB_F_Slope	0.054	0.369
9_CB_F_Slope	0.06	0.423
9_CB_F_Slope	0.07	0.45
9_CB_F_Slope	1	0.45
90mmPlate	Rating	0
90mmPlate	0.25	0.008876361
90mmPlate	0.5	0.01255307
90mmPlate	0.75	0.015374308
90mmPlate	1	0.017752722
90mmPlate	1.25	0.019848147
90mmPlate	1.5	0.021742555
90mmPlate	1.75	0.023484644
90mmPlate	2	0.02510614
90mmPlate	2.25	0.026629083
90mmPlate	2.5	0.028069518
90mmPlate	2.75	0.029439559

DICB_MTO_CHART_4.20	0.46	0.9
DICB_MTO_CHART_4.20	0.5	1.1
DICB_MTO_CHART_4.20_extrap	Rating	0
DICB_MTO_CHART_4.20_extrap	0.02	0
DICB_MTO_CHART_4.20_extrap	0.04	0.02
DICB_MTO_CHART_4.20_extrap	0.06	0.03
DICB_MTO_CHART_4.20_extrap	0.08	0.048
DICB_MTO_CHART_4.20_extrap	0.1	0.065
DICB_MTO_CHART_4.20_extrap	0.12	0.085
DICB_MTO_CHART_4.20_extrap	0.14	0.11
DICB_MTO_CHART_4.20_extrap	0.16	0.15
DICB_MTO_CHART_4.20_extrap	0.18	0.18
DICB_MTO_CHART_4.20_extrap	0.2	0.2
DICB_MTO_CHART_4.20_extrap	0.22	0.24
DICB_MTO_CHART_4.20_extrap	0.24	0.28
DICB_MTO_CHART_4.20_extrap	0.26	0.34
DICB_MTO_CHART_4.20_extrap	0.28	0.37
DICB_MTO_CHART_4.20_extrap	0.3	0.43
DICB_MTO_CHART_4.20_extrap	0.32	0.47
DICB_MTO_CHART_4.20_extrap	0.34	0.54
DICB_MTO_CHART_4.20_extrap	0.36	0.58
DICB_MTO_CHART_4.20_extrap	0.38	0.65
DICB_MTO_CHART_4.20_extrap	0.4	0.7
DICB_MTO_CHART_4.20_extrap	0.46	0.9
DICB_MTO_CHART_4.20_extrap	0.5	1.1
DICB_MTO_CHART_4.20_extrap	0.6	1.6
DICB_MTO_CHART_4.20_extrap	0.7	2
;MTO CHART 4.20: 6:1 slope		
;ICD 111 l/s at 3.3 m per drawing		
DICB_Oligo	Rating	0
DICB_Oligo	0.02	0.021
DICB_Oligo	0.04	0.04
DICB_Oligo	0.06	0.06
DICB_Oligo	0.08	0.095
DICB_Oligo	0.09	0.11
DICB_Oligo	3.3	0.11
HYDROVEX100-VHV-1	Rating	0
HYDROVEX100-VHV-1	0.2	0.0001
HYDROVEX100-VHV-1	0.5	0.007
HYDROVEX100-VHV-1	1	0.0105
HYDROVEX100-VHV-1	1.5	0.0125
HYDROVEX100-VHV-1	2	0.014
HYDROVEX100-VHV-1	3	0.018
HYDROVEX100-VHV-1	4	0.021
HYDROVEX100-VHV-1	6	0.026
HYDROVEX125-VHV-2	Rating	0
HYDROVEX125-VHV-2	0.2	0.0001
HYDROVEX125-VHV-2	0.6	0.014
HYDROVEX125-VHV-2	1	0.0185
HYDROVEX125-VHV-2	1.5	0.023
HYDROVEX125-VHV-2	2	0.027
HYDROVEX125-VHV-2	2.5	0.03
HYDROVEX125-VHV-2	3.5	0.0355
HYDROVEX125-VHV-2	4.5	0.04
HYDROVEX125-VHV-2	6	0.046
HYDROVEX150-VHV-2	Rating	0
HYDROVEX150-VHV-2	0.2	0.0001

90mmPlate	3	0.030748616
90mmPlate	3.25	0.032004175
90mmPlate	3.5	0.033212302
90mmPlate	3.75	0.034377998
90mmPlate	4	0.035505444
90mmPlate	4.25	0.036598174
90mmPlate	4.5	0.03765921
90mmPlate	4.75	0.03869116
90mmPlate	5	0.039696293
Curb_Inlet_Slope	Rating	0
Curb_Inlet_Slope	0.01	0.001
Curb_Inlet_Slope	0.015	0.002
Curb_Inlet_Slope	0.021	0.004
Curb_Inlet_Slope	0.03	0.006
Curb_Inlet_Slope	0.04	0.009
Curb_Inlet_Slope	0.05	0.013
Curb_Inlet_Slope	0.054	0.014
Curb_Inlet_Slope	0.06	0.017
Curb_Inlet_Slope	0.07	0.021
Curb_Inlet_Slope	0.08	0.026
Curb_Inlet_Slope	0.09	0.031
Curb_Inlet_Slope	0.14	0.05
Curb_Inlet_Slope	1	0.05
;imported from Leslie-Arlington model		
curve_J23_S	Rating	0
curve_J23_S	0.028	315.597
curve_J23_S	0.057	346.465
curve_J23_S	0.085	360.09
curve_J23_S	0.114	362
curve_J23_S	0.142	362
curve_J23_S	0.171	362
curve_J23_S	0.193	362
curve_J23_S	0.227	362
curve_J23_S	0.256	362
curve_J23_S	0.27	362
curve_J23_S	0.5	362
curve_J23_S	1	362
;2:1 Slope		
DICB_MTO_CHART_4.20	Rating	0
DICB_MTO_CHART_4.20	0.02	0
DICB_MTO_CHART_4.20	0.04	0.02
DICB_MTO_CHART_4.20	0.06	0.03
DICB_MTO_CHART_4.20	0.08	0.048
DICB_MTO_CHART_4.20	0.1	0.065
DICB_MTO_CHART_4.20	0.12	0.085
DICB_MTO_CHART_4.20	0.14	0.11
DICB_MTO_CHART_4.20	0.16	0.15
DICB_MTO_CHART_4.20	0.18	0.18
DICB_MTO_CHART_4.20	0.2	0.2
DICB_MTO_CHART_4.20	0.22	0.24
DICB_MTO_CHART_4.20	0.24	0.28
DICB_MTO_CHART_4.20	0.26	0.34
DICB_MTO_CHART_4.20	0.28	0.37
DICB_MTO_CHART_4.20	0.3	0.43
DICB_MTO_CHART_4.20	0.32	0.47
DICB_MTO_CHART_4.20	0.34	0.54
DICB_MTO_CHART_4.20	0.36	0.58
DICB_MTO_CHART_4.20	0.38	0.65
DICB_MTO_CHART_4.20	0.4	0.7

HYDROVEX150-VHV-2	0.75	0.022
HYDROVEX150-VHV-2	1	0.026
HYDROVEX150-VHV-2	1.5	0.032
HYDROVEX150-VHV-2	2	0.038
HYDROVEX150-VHV-2	3	0.047
HYDROVEX150-VHV-2	4.5	0.057
HYDROVEX150-VHV-2	6	0.067
HYDROVEX200-VHV-2	Rating	0
HYDROVEX200-VHV-2	0.2	0.007
HYDROVEX200-VHV-2	0.5	0.001
HYDROVEX200-VHV-2	1	0.044
HYDROVEX200-VHV-2	1.5	0.056
HYDROVEX200-VHV-2	2	0.065
HYDROVEX200-VHV-2	2.5	0.073
HYDROVEX200-VHV-2	3	0.082
HYDROVEX200-VHV-2	4	0.094
HYDROVEX200-VHV-2	5	0.112
HYDROVEX200-VHV-2	6	0.135
HYDROVEX250-VHV-2	Rating	0
HYDROVEX250-VHV-2	0.2	0.0001
HYDROVEX250-VHV-2	0.5	0.007
HYDROVEX250-VHV-2	1	0.044
HYDROVEX250-VHV-2	1.25	0.074
HYDROVEX250-VHV-2	1.5	0.085
HYDROVEX250-VHV-2	2	0.1
HYDROVEX250-VHV-2	2.5	0.115
HYDROVEX250-VHV-2	3	0.125
HYDROVEX250-VHV-2	4	0.145
HYDROVEX250-VHV-2	5	0.16
HYDROVEX250-VHV-2	6	0.18
HYDROVEX50VHV-1	Rating	0
HYDROVEX50VHV-1	0.2	0.0016
HYDROVEX50VHV-1	0.5	0.002
HYDROVEX50VHV-1	1	0.003
HYDROVEX50VHV-1	1.5	0.0035
HYDROVEX50VHV-1	2	0.0042
HYDROVEX50VHV-1	2.5	0.0046
HYDROVEX50VHV-1	3	0.0051
HYDROVEX50VHV-1	3.5	0.0055
HYDROVEX50VHV-1	4	0.006
HYDROVEX50VHV-1	4.5	0.0062
HYDROVEX50VHV-1	5	0.0066
HYDROVEX50VHV-1	5.5	0.007
HYDROVEX50VHV-1	6	0.0072
ICD_1_CB_F_Sag_21_L/s	Rating	0
ICD_1_CB_F_Sag_21_L/s	0.05	0
ICD_1_CB_F_Sag_21_L/s	0.069	0.021
ICD_1_CB_F_Sag_21_L/s	1	0.021
ICD_10_1/s_1_CB_F_+1+CB_St_SAG	Rating	0
ICD_10_1/s_1_CB_F_+1+CB_St_SAG	0.05	0.018
ICD_10_1/s_1_CB_F_+1+CB_St_SAG	0.052	0.02
ICD_10_1/s_1_CB_F_+1+CB_St_SAG	3	0.02
ICD_10_1/s_1_CB_F_SAG	Rating	0
ICD_10_1/s_1_CB_F_SAG	0.05	0.01
ICD_10_1/s_1_CB_F_SAG	3	0.01

ICD_10_1/s_1_CB_F_Slope Rating 0 0
 ICD_10_1/s_1_CB_F_Slope 0.01 0.001
 ICD_10_1/s_1_CB_F_Slope 0.015 0.003
 ICD_10_1/s_1_CB_F_Slope 0.021 0.007
 ICD_10_1/s_1_CB_F_Slope 0.024857143 0.01
 ICD_10_1/s_1_CB_F_Slope 3 0.01

ICD_10_1/s_1_CB_St_Sag Rating 0 0
 ICD_10_1/s_1_CB_St_Sag 0.05 0.008
 ICD_10_1/s_1_CB_St_Sag 0.054 0.01
 ICD_10_1/s_1_CB_St_Sag 3 0.01

ICD_10_1/s_1_CB_St_Slope Rating 0 0
 ICD_10_1/s_1_CB_St_Slope 0.01 0.001
 ICD_10_1/s_1_CB_St_Slope 0.015 0.003
 ICD_10_1/s_1_CB_St_Slope 0.021 0.006
 ICD_10_1/s_1_CB_St_Slope 0.027 0.01
 ICD_10_1/s_1_CB_St_Slope 3 0.01

ICD_10_1/s_1_CB_F+ICB_St_SLOPE Rating 0 0
 ICD_10_1/s_1_CB_F+ICB_St_SLOPE 0.01 0.002
 ICD_10_1/s_1_CB_F+ICB_St_SLOPE 0.015 0.006
 ICD_10_1/s_1_CB_F+ICB_St_SLOPE 0.021 0.013
 ICD_10_1/s_1_CB_F+ICB_St_SLOPE 0.025846154 0.02
 ICD_10_1/s_1_CB_F+ICB_St_SLOPE 3 0.02

ICD_10_1/s_2_CB_CI_Sag Rating 0 0
 ICD_10_1/s_2_CB_CI_Sag 0.018 0.004
 ICD_10_1/s_2_CB_CI_Sag 0.03 0.02
 ICD_10_1/s_2_CB_CI_Sag 3 0.02

ICD_10_1/s_2_CB_CI_SLOPE Rating 0 0
 ICD_10_1/s_2_CB_CI_SLOPE 0.01 0.002
 ICD_10_1/s_2_CB_CI_SLOPE 0.015 0.004
 ICD_10_1/s_2_CB_CI_SLOPE 0.021 0.008
 ICD_10_1/s_2_CB_CI_SLOPE 0.03 0.012
 ICD_10_1/s_2_CB_CI_SLOPE 0.04 0.018
 ICD_10_1/s_2_CB_CI_SLOPE 0.0425 0.02
 ICD_10_1/s_2_CB_CI_SLOPE 3 0.02

ICD_10_1/s_2_CB_St_Sag Rating 0 0
 ICD_10_1/s_2_CB_St_Sag 0.05 0.016
 ICD_10_1/s_2_CB_St_Sag 0.054285714 0.02
 ICD_10_1/s_2_CB_St_Sag 3 0.02

ICD_10_1/s_2_CB_St_Slope Rating 0 0
 ICD_10_1/s_2_CB_St_Slope 0.01 0.002
 ICD_10_1/s_2_CB_St_Slope 0.015 0.006
 ICD_10_1/s_2_CB_St_Slope 0.021 0.012
 ICD_10_1/s_2_CB_St_Slope 0.027 0.02
 ICD_10_1/s_2_CB_St_Slope 3 0.02

ICD_10_1/s_4_CB_St_Slope Rating 0 0
 ICD_10_1/s_4_CB_St_Slope 0.01 0.004
 ICD_10_1/s_4_CB_St_Slope 0.015 0.012
 ICD_10_1/s_4_CB_St_Slope 0.021 0.024
 ICD_10_1/s_4_CB_St_Slope 0.027 0.04
 ICD_10_1/s_4_CB_St_Slope 3 0.04

ICD_2_CB_F_Sag_21_1/s Rating 0 0
 ICD_2_CB_F_Sag_21_1/s 0.05 0.02
 ICD_2_CB_F_Sag_21_1/s 0.055 0.021

ICD_2_CB_F_Sag_21_1/s 1 0.021

ICD_2_CB_F_Sag_30.5_L/s Rating 0 0
 ICD_2_CB_F_Sag_30.5_L/s 0.05 0.02
 ICD_2_CB_F_Sag_30.5_L/s 0.06 0.0305
 ICD_2_CB_F_Sag_30.5_L/s 1 0.0305

ICD_2_CB_F_SLOPE_21_1/s Rating 0 0
 ICD_2_CB_F_SLOPE_21_1/s 0.01 0.002
 ICD_2_CB_F_SLOPE_21_1/s 0.015 0.006
 ICD_2_CB_F_SLOPE_21_1/s 0.021 0.014
 ICD_2_CB_F_SLOPE_21_1/s 0.026 0.021
 ICD_2_CB_F_SLOPE_21_1/s 1 0.021

;Typical perforated MH grate at LP
 RC_MH_LP_66PICK Rating 0 0
 RC_MH_LP_66PICK 0.121 0.040940909
 RC_MH_LP_66PICK 0.182 0.049715909
 RC_MH_LP_66PICK 0.2 0.051927273
 RC_MH_LP_66PICK 0.244 0.057138636
 RC_MH_LP_66PICK 0.305 0.063636364

RC_MH_LP_66PICK_8CM_ELEVATED Rating 0 0
 RC_MH_LP_66PICK_8CM_ELEVATED 0.28 0.051927273
 RC_MH_LP_66PICK_8CM_ELEVATED 0.262 0.049715909
 RC_MH_LP_66PICK_8CM_ELEVATED 0.228 0.051927273
 RC_MH_LP_66PICK_8CM_ELEVATED 0.24 0.057138636
 RC_MH_LP_66PICK_8CM_ELEVATED 0.385 0.063636364

roofdrainMech Rating 0 0
 roofdrainMech 0.0254 0.011671703
 roofdrainMech 0.0508 0.013564412
 roofdrainMech 0.0762 0.015457121
 roofdrainMech 0.1016 0.017349829
 roofdrainMech 0.127 0.019242538
 roofdrainMech 0.1524 0.021135247

;Watts
 RoofDrainx2 Rating 0 0
 RoofDrainx2 0.0254 0.000630903
 RoofDrainx2 0.0508 0.001261806
 RoofDrainx2 0.0762 0.001892709
 RoofDrainx2 0.1016 0.002523612
 RoofDrainx2 0.127 0.003154514
 RoofDrainx2 0.1524 0.003785417

;Watts roof Drain
 RoofDrainx20 Rating 0 0
 RoofDrainx20 0.0254 0.006309029
 RoofDrainx20 0.0508 0.012618058
 RoofDrainx20 0.0762 0.018927087
 RoofDrainx20 0.1016 0.025236115
 RoofDrainx20 0.127 0.031545144
 RoofDrainx20 0.1524 0.037854173

S_ICD_10_1/s_1_CB_F_+1+CB_St_SAG Rating 0 0
 S_ICD_10_1/s_1_CB_F_+1+CB_St_SAG 0.027777778 0.01
 S_ICD_10_1/s_1_CB_F_+1+CB_St_SAG 3 0.01

S_ICD_10_1/s_1_CB_F+ICB_St_SLOPE Rating 0 0
 S_ICD_10_1/s_1_CB_F+ICB_St_SLOPE 0.01 0.002

S_ICD_10_1/s_1_CB_F+ICB_St_SLOPE 0.015 0.006
 S_ICD_10_1/s_1_CB_F+ICB_St_SLOPE 0.018 0.01
 S_ICD_10_1/s_1_CB_F+ICB_St_SLOPE 3 0.01

S_ICD_10_1/s_2_CB_St_Sag Rating 0 0
 S_ICD_10_1/s_2_CB_St_Sag 0.03 0.01
 S_ICD_10_1/s_2_CB_St_Sag 3 0.01

S_ICD_10_1/s_2_CB_St_Slope Rating 0 0
 S_ICD_10_1/s_2_CB_St_Slope 0.01 0.002
 S_ICD_10_1/s_2_CB_St_Slope 0.015 0.006
 S_ICD_10_1/s_2_CB_St_Slope 0.019 0.01
 S_ICD_10_1/s_2_CB_St_Slope 3 0.01

;Original area=206.469, shape curve area=206.419
 0.510_1 Shape 0 0
 0.510_1 0.001 0.481
 0.510_1 0.005 0.907
 0.510_1 0.015 1.558
 0.510_1 0.035 2.717
 0.510_1 0.036 2.77
 0.510_1 0.059 3.77
 0.510_1 0.065 4.006
 0.510_1 0.101 5.162
 0.510_1 0.102 5.183
 0.510_1 0.115 5.469
 0.510_1 0.132 5.721
 0.510_1 0.156 5.984
 0.510_1 0.182 6.213
 0.510_1 0.199 6.337
 0.510_1 0.241 6.607
 0.510_1 0.288 6.847
 0.510_1 0.865 6.847
 0.510_1 1 0

;Original area=73.675, shape curve area=73.653
 0.510_2 Shape 0 0
 0.510_2 0.021 0.161
 0.510_2 0.034 0.254
 0.510_2 0.052 0.374
 0.510_2 0.115 0.712
 0.510_2 0.207 1.18
 0.510_2 0.309 1.628
 0.510_2 0.423 2.068
 0.510_2 0.474 2.254
 0.510_2 0.837 3.511
 0.510_2 0.919 3.814
 0.510_2 0.976 1.119
 0.510_2 1 0

;Original area=19.151, shape curve area=19.155
 0.510_3 Shape 0 0
 0.510_3 0.06 0.273
 0.510_3 0.17 0.741
 0.510_3 0.485 2.023
 0.510_3 0.823 3.298
 0.510_3 0.928 3.669
 0.510_3 1 0

;Original area=106.136, shape curve area=106.128
 1.030_1 Shape 0 0
 1.030_1 0.001 0.069

1.030_1 0.007 0.2
 1.030_1 0.016 0.353
 1.030_1 0.022 0.432
 1.030_1 0.077 1.033
 1.030_1 0.095 1.247
 1.030_1 0.119 1.542
 1.030_1 0.126 2.216
 1.030_1 0.146 3.284
 1.030_1 0.161 4.129
 1.030_1 0.163 4.345
 1.030_1 0.173 4.4
 1.030_1 0.185 4.438
 1.030_1 0.191 4.487
 1.030_1 0.213 4.581
 1.030_1 0.22 4.654
 1.030_1 0.226 4.875
 1.030_1 1 4.875

;Original area=64.922, shape curve area=64.919
 1.030_2 Shape 0 0
 1.030_2 0.002 0.037
 1.030_2 0.017 0.16
 1.030_2 0.031 0.328
 1.030_2 0.077 0.979
 1.030_2 0.103 1.201
 1.030_2 0.111 1.238
 1.030_2 0.159 1.47
 1.030_2 0.298 2.075
 1.030_2 0.394 2.566
 1.030_2 0.407 2.657
 1.030_2 0.415 2.781
 1.030_2 0.437 2.948
 1.030_2 0.528 3.531
 1.030_2 0.599 3.928
 1.030_2 0.7 4.439
 1.030_2 0.743 4.695
 1.030_2 0.758 4.814
 1.030_2 0.769 4.986
 1.030_2 0.788 5.188
 1.030_2 0.94 6.549
 1.030_2 1 7.206

;Original area=63.715, shape curve area=63.721
 1.030_3 Shape 0 0
 1.030_3 0.002 0.334
 1.030_3 0.018 0.788
 1.030_3 0.024 0.922
 1.030_3 0.044 1.265
 1.030_3 0.06 1.416
 1.030_3 0.094 1.65
 1.030_3 0.106 1.737
 1.030_3 0.178 2.15
 1.030_3 0.277 2.665
 1.030_3 0.467 3.757
 1.030_3 0.758 5.363
 1.030_3 0.808 5.601
 1.030_3 0.946 6.128
 1.030_3 1 6.488

;Original area=113.856, shape curve area=113.928
 1170_1 Shape 0 0
 1170_1 0.001 0.023

1170_1	0.009	0.077
1170_1	0.01	0.09
1170_1	0.017	0.279
1170_1	0.02	0.378
1170_1	0.03	0.411
1170_1	0.042	0.447
1170_1	0.06	0.561
1170_1	0.065	0.573
1170_1	0.088	0.675
1170_1	0.115	0.753
1170_1	0.137	0.822
1170_1	0.157	0.944
1170_1	0.17	1.029
1170_1	0.176	1.053
1170_1	0.181	1.158
1170_1	0.187	1.186
1170_1	0.457	1.723
1170_1	0.558	1.93
1170_1	0.586	2.165
1170_1	0.596	2.223
1170_1	0.597	3.692
1170_1	1	0

;Original area=51.972, shape curve area=51.991		
1170_2	Shape	0
1170_2		0.032
1170_2		0.046
1170_2		0.054
1170_2		0.105
1170_2		0.179
1170_2		0.242
1170_2		0.303
1170_2		0.327
1170_2		0.336
1170_2		0.337
1170_2		0.338
1170_2		0.366
1170_2		0.95
1170_2		1

;Proposed Iris Street Crossing		
;Original area=35.441, shape curve area=35.429		
2961	Shape	0
2961		0.052
2961		0.26
2961		0.261
2961		0.294
2961		0.314
2961		0.499
2961		0.519
2961		0.52
2961		1

;Proposed Culvert under Transitway/LRT		
;Original area=26.27, shape curve area=26.261		
3235	Shape	0
3235		0.32
3235		0.321
3235		1

209+150	Storage	0
209+150		1.725

209+150		2.25	416
209+150		2.251	1005
209+150		2.42	1005
209+150		10	1005
CB1	Storage	0	0.36
CB1		1.7	0.36
CB10		1.82	43.76
CB10	Storage	0	0
CB10		1.83	0.72
CB11	Storage	0	0
CB11		2.42	0.72
CB12	Storage	0	0.36
CB12		3.18	0.36
CB12		3.3	61.86
CB13	Storage	0	0.36
CB13		1.44	0.36
CB13		1.72	253.36
CB14	Storage	0	0.36
CB14		1.73	0.36
CB14		2.05	223.36
CB15	Storage	0	0.36
CB15		3	0.36
CB15		3.16	21
CB16	Storage	0	0.36
CB16		4.2	0.36
CB2	Storage	0	0.36
CB2		1.7	0.36
CB2		2.02	9.28
CB20	Storage	0	0.36
CB20		1.7	0.36
CB3	Storage	0	0.36
CB3		2	0.36
CB3		2.13	99.06
CB4	Storage	0	0.36
CB4		1.92	0.36
CB4		2.05	40.28
CB5	Storage	0	0.36
CB5		1.8	0.36
CB5		1.92	34.28
CB6	Storage	0	0.36
CB6		2.6	0.36
CB6		2.87	154.7
CB7	Storage	0	0.36
CB7		2.07	0.36
CB7		2.29	113.8
CB8	Storage	0	0.36
CB8		1.65	0.36

CB8		1.77	33.52
;NEEDS CONFIRMED			
CB1	Storage	0	0
CB1		1	0.72
CB1		1.06	24
CBMH108	Storage	0	0
CBMH108		2.93	0.72
EXCB02	Storage	0	0.36
EXCB02		2.53	0.36
EXCB02		2.85	274.1
left_parking_lot	Storage	0	0
left_parking_lot		2	10000
left_parking_lot		10	10000
MC3500	Storage	0	145.93
MC3500		0.05	145.93
MC3500		0.08	145.93
MC3500		0.1	145.93
MC3500		0.13	145.93
MC3500		0.15	145.93
MC3500		0.18	145.93
MC3500		0.2	145.93
MC3500		0.23	145.93
MC3500		0.25	325.75
MC3500		0.28	324.16
MC3500		0.3	323.07
MC3500		0.33	321.99
MC3500		0.36	320.82
MC3500		0.38	319.66
MC3500		0.41	318.42
MC3500		0.43	317.14
MC3500		0.46	315.77
MC3500		0.48	314.32
MC3500		0.51	312.82
MC3500		0.53	311.24
MC3500		0.56	309.59
MC3500		0.58	307.82
MC3500		0.61	306
MC3500		0.63	304.11
MC3500		0.66	301.98
MC3500		0.69	299.86
MC3500		0.71	297.65
MC3500		0.74	295.27
MC3500		0.76	292.75
MC3500		0.79	290.12
MC3500		0.81	287.36
MC3500		0.84	284.46
MC3500		0.86	281.41
MC3500		0.89	278.2
MC3500		0.91	274.82
MC3500		0.94	271.26
MC3500		0.97	267.44
MC3500		0.99	263.43
MC3500		1.02	259.19
MC3500		1.04	254.59
MC3500		1.07	249.77
MC3500		1.09	244.48
MC3500		1.12	238.87

MC3500		1.14	232.66
MC3500		1.17	225.81
MC3500		1.19	218.12
MC3500		1.22	209.33
MC3500		1.24	198.1
MC3500		1.27	180.85
MC3500		1.3	166.52
MC3500		1.32	160.93
MC3500		1.35	155.82
MC3500		1.37	148.84
MC3500		1.4	145.93
MC3500		1.42	145.93
MC3500		1.45	145.93
MC3500		1.47	145.93
MC3500		1.5	145.93
MC3500		1.52	145.93
MC3500		1.55	145.93
MC3500		1.57	145.93
MC3500		1.6	145.93
MC3500		1.63	145.93
MC3500		1.65	145.93
MC3500		1.68	145.93
MCT200	Storage	0	0
MCT200		0.49	0
MCT200		0.5	58.73
MCT200		0.55	58.73
MCT200		0.58	58.73
MCT200		0.6	58.73
MCT200		0.63	58.73
MCT200		0.65	58.73
MCT200		0.68	58.73
MCT200		0.7	58.73
MCT200		0.73	58.73
MCT200		0.75	107.98
MCT200		0.78	107.65
MCT200		0.8	107.48
MCT200		0.83	107.28
MCT200		0.86	107
MCT200		0.88	106.8
MCT200		0.91	106.65
MCT200		0.93	106.42
MCT200		0.96	106.18
MCT200		0.98	105.92
MCT200		1.01	105.64
MCT200		1.03	105.35
MCT200		1.06	105.06
MCT200		1.08	104.59
MCT200		1.11	104.4
MCT200		1.14	104.04
MCT200		1.16	103.67
MCT200		1.19	103.29
MCT200		1.21	102.82
MCT200		1.24	102.48
MCT200		1.26	102.05
MCT200		1.29	101.6
MCT200		1.31	101.04
MCT200		1.34	100.6
MCT200		1.36	100.12
MCT200		1.39	99.59
MCT200		1.41	99.05

MCT200	1.44	98.49
MCT200	1.47	97.89
MCT200	1.49	97.27
MCT200	1.52	96.64
MCT200	1.54	95.97
MCT200	1.57	95.29
MCT200	1.59	94.5
MCT200	1.62	93.85
MCT200	1.64	93.1
MCT200	1.67	92.33
MCT200	1.69	91.53
MCT200	1.72	90.7
MCT200	1.74	89.83
MCT200	1.77	88.92
MCT200	1.8	87.96
MCT200	1.82	86.95
MCT200	1.85	85.88
MCT200	1.87	84.81
MCT200	1.9	83.65
MCT200	1.92	82.45
MCT200	1.95	81.19
MCT200	1.97	79.83
MCT200	2	78.38
MCT200	2.02	76.79
MCT200	2.05	75.03
MCT200	2.07	73.04
MCT200	2.1	70.62
MCT200	2.13	66.88
MCT200	2.15	63.89
MCT200	2.18	62.76
MCT200	2.2	61.84
MCT200	2.23	60.87
MCT200	2.25	59.41
MCT200	2.28	58.73
MCT200	2.3	58.73
MCT200	2.33	58.73
MCT200	2.35	58.73
MCT200	2.38	58.73
MCT200	2.41	58.73
MCT200	2.43	58.73
MCT200	2.46	58.73
MCT200	2.48	58.73
MCT200	2.51	58.73
MCT200	2.53	58.73
MCT200	2.56	58.73
Overland_flow_swale Storage	0	1
Overland_flow_swale	0.005	2
Overland_flow_swale	0.01	5
Overland_flow_swale	0.015	10
Overland_flow_swale	0.02	15
Overland_flow_swale	0.025	20
Overland_flow_swale	0.03	24
Overland_flow_swale	0.035	29
Overland_flow_swale	0.04	33
Overland_flow_swale	0.045	37
Overland_flow_swale	0.05	41
Overland_flow_swale	0.055	45
Overland_flow_swale	0.06	50
Overland_flow_swale	0.065	57
Overland_flow_swale	0.07	63

Overland_flow_swale	0.075	71
Overland_flow_swale	0.08	78
Overland_flow_swale	0.085	86
Overland_flow_swale	0.09	93
Overland_flow_swale	0.095	102
Overland_flow_swale	0.1	110
Overland_flow_swale	0.105	119
Overland_flow_swale	0.11	128
Overland_flow_swale	0.115	137
Overland_flow_swale	0.12	147
Overland_flow_swale	0.125	156
Overland_flow_swale	0.13	166
Overland_flow_swale	0.135	177
Overland_flow_swale	0.14	187
Overland_flow_swale	0.145	198
Overland_flow_swale	0.15	210
Overland_flow_swale	0.155	221
Overland_flow_swale	0.16	233
Overland_flow_swale	0.165	245
Overland_flow_swale	0.17	258
Overland_flow_swale	0.175	271
Overland_flow_swale	0.18	285
Overland_flow_swale	0.185	299
Overland_flow_swale	0.19	312
Overland_flow_swale	0.195	326
Overland_flow_swale	0.2	339
Overland_flow_swale	0.205	354
Overland_flow_swale	0.21	368
Overland_flow_swale	0.215	383
Overland_flow_swale	0.22	398
Overland_flow_swale	0.225	414
Overland_flow_swale	0.23	429
Overland_flow_swale	0.235	445
Overland_flow_swale	0.24	460
Overland_flow_swale	0.245	476
Overland_flow_swale	0.25	491
Overland_flow_swale	0.255	507
Overland_flow_swale	0.26	523
Overland_flow_swale	0.265	539
Overland_flow_swale	0.27	555
Overland_flow_swale	0.275	572
Overland_flow_swale	0.28	588
Overland_flow_swale	0.285	605
Overland_flow_swale	0.29	621
Overland_flow_swale	0.295	638
Overland_flow_swale	0.3	654
Overland_flow_swale	0.305	671
Overland_flow_swale	0.31	687
Overland_flow_swale	0.315	703
Overland_flow_swale	0.32	719
Overland_flow_swale	0.325	735
Overland_flow_swale	0.33	751
Overland_flow_swale	0.335	767
Overland_flow_swale	0.34	820
Overland_flow_swale	0.35	849
Overland_flow_swale	0.355	862
Overland_flow_swale	0.365	889
Overland_flow_swale	0.37	902
Overland_flow_swale	0.385	939
Overland_flow_swale	0.395	963
Overland_flow_swale	0.41	998

Overland_flow_swale	0.425	1032
Overland_flow_swale	0.43	1044
Overland_flow_swale	0.44	1066
Overland_flow_swale	0.445	1077
Overland_flow_swale	0.45	1089
Overland_flow_swale	0.46	1111
Overland_flow_swale	0.465	1122
Overland_flow_swale	0.485	1166
Overland_flow_swale	0.5	1200
Overland_flow_swale	0.51	1222
Overland_flow_swale	0.515	1233
Overland_flow_swale	0.53	1267
Overland_flow_swale	0.54	1291
Overland_flow_swale	0.56	1340
Overland_flow_swale	0.57	1366
Overland_flow_swale	0.575	1379
Overland_flow_swale	0.585	1406
Overland_flow_swale	0.595	1435
Overland_flow_swale	0.61	1485
Overland_flow_swale	0.625	1605
Overland_flow_swale	0.63	1622
Overland_flow_swale	0.655	1705
Overland_flow_swale	0.66	1723
Overland_flow_swale	0.68	1796
Overland_flow_swale	0.685	1815
Overland_flow_swale	0.7	1873
Overland_flow_swale	0.72	1951
Overland_flow_swale	0.74	2032
Overland_flow_swale	0.745	2052
Overland_flow_swale	0.76	2111
Overland_flow_swale	0.77	2150
Overland_flow_swale	0.785	2211
Overland_flow_swale	0.805	2294
Overland_flow_swale	0.81	2315
Overland_flow_swale	0.815	2336
;Small Pond		
Pond1 Storage	0	0
Pond1	0.07	7.87
Pond1	0.27	17.4
Pond1	0.47	30.07
Pond1	0.67	45.89
Pond1	0.87	64.96
Pond1	1.07	86.96
Pond1	1.27	109.54
Pond1	1.47	139.67
Pond1	1.77	0
;Big pond		
Pond2 Storage	0	0
Pond2	0.09	2.08
Pond2	0.29	53.72
Pond2	0.49	110.23
Pond2	0.69	137.18
Pond2	0.89	167.25
Pond2	1.09	200.41
Pond2	1.29	236.68
Pond2	1.39	255.98
Pond2	1.49	277.75
Pond2	1.69	319.33
Pond2	1.99	6.24

;Big Pond			
R1 Storage	0	0	
R1	0.15	2107.86	
;Rupdate			
Rupdate Storage	0	0	
Rupdate	0.15	3087.4	
;R3			
R3 Storage	0	0	
R3	0.15	143.33	
;155 m3			
StormBrix Storage	0	0	
StormBrix	0.3048	127.1331651	
StormBrix	0.6096	127.1331651	
StormBrix	0.9144	127.1331651	
StormBrix	1.2192	127.1331651	
;562 m3			
StormBrixold Storage	0.6	234.875	
StormBrixold	1.2	234.875	
StormBrixold	1.8	234.875	
StormBrixold	2.4	234.875	
;Stormbrixxl70			
Stormbrixxl70 Storage	0	0	
Stormbrixxl70	0.3048	139.5	
Stormbrixxl70	0.6096	139.5	
Stormbrixxl70	0.9144	139.5	
Stormbrixxl70	1.22	139.5	
[TIMESERIES]			
;Name Date Time Value			
;-----			
100yr_3hr_Chicago	0:10	6.05	
100yr_3hr_Chicago	0:20	7.54	
100yr_3hr_Chicago	0:30	10.17	
100yr_3hr_Chicago	0:40	15.98	
100yr_3hr_Chicago	0:50	40.76	
100yr_3hr_Chicago	1:00	178.56	
100yr_3hr_Chicago	1:10	54.04	
100yr_3hr_Chicago	1:20	27.31	
100yr_3hr_Chicago	1:30	18.23	
100yr_3hr_Chicago	1:40	13.73	
100yr_3hr_Chicago	1:50	11.05	
100yr_3hr_Chicago	2:00	9.28	
100yr_3hr_Chicago	2:10	8.02	
100yr_3hr_Chicago	2:20	7.08	
100yr_3hr_Chicago	2:30	6.34	
100yr_3hr_Chicago	2:40	5.76	
100yr_3hr_Chicago	2:50	5.28	
100yr_3hr_Chicago	3:00	4.88	
100yr_3hr_Chicago_Increase_20percent	0:10	7.26	
100yr_3hr_Chicago_Increase_20percent	0:20	9.048	
100yr_3hr_Chicago_Increase_20percent	0:30	12.204	
100yr_3hr_Chicago_Increase_20percent	0:40	19.176	
100yr_3hr_Chicago_Increase_20percent	0:50	48.912	
100yr_3hr_Chicago_Increase_20percent	1:00	214.272	
100yr_3hr_Chicago_Increase_20percent	1:10	64.848	
100yr_3hr_Chicago_Increase_20percent	1:20	32.772	
100yr_3hr_Chicago_Increase_20percent	1:30	21.876	
100yr_3hr_Chicago_Increase_20percent	1:40	16.476	

100yr_3hr_Chicago_Increase_20percent	1:50	13.26
100yr_3hr_Chicago_Increase_20percent	2:00	11.136
100yr_3hr_Chicago_Increase_20percent	2:10	9.624
100yr_3hr_Chicago_Increase_20percent	2:20	8.496
100yr_3hr_Chicago_Increase_20percent	2:30	7.608
100yr_3hr_Chicago_Increase_20percent	2:40	6.912
100yr_3hr_Chicago_Increase_20percent	2:50	6.336
100yr_3hr_Chicago_Increase_20percent	3:00	5.856
100yr_6hr_Chicago	0:10	2.91
100yr_6hr_Chicago	0:20	3.17
100yr_6hr_Chicago	0:30	3.48
100yr_6hr_Chicago	0:40	3.88
100yr_6hr_Chicago	0:50	4.39
100yr_6hr_Chicago	1:00	5.08
100yr_6hr_Chicago	1:10	6.05
100yr_6hr_Chicago	1:20	7.55
100yr_6hr_Chicago	1:30	10.17
100yr_6hr_Chicago	1:40	15.98
100yr_6hr_Chicago	1:50	40.67
100yr_6hr_Chicago	2:00	178.56
100yr_6hr_Chicago	2:10	54.04
100yr_6hr_Chicago	2:20	27.31
100yr_6hr_Chicago	2:30	18.23
100yr_6hr_Chicago	2:40	13.73
100yr_6hr_Chicago	2:50	11.05
100yr_6hr_Chicago	3:00	9.28
100yr_6hr_Chicago	3:10	8.02
100yr_6hr_Chicago	3:20	7.08
100yr_6hr_Chicago	3:30	6.34
100yr_6hr_Chicago	3:40	5.76
100yr_6hr_Chicago	3:50	5.28
100yr_6hr_Chicago	4:00	4.88
100yr_6hr_Chicago	4:10	4.54
100yr_6hr_Chicago	4:20	4.25
100yr_6hr_Chicago	4:30	3.99
100yr_6hr_Chicago	4:40	3.77
100yr_6hr_Chicago	4:50	3.57
100yr_6hr_Chicago	5:00	3.4
100yr_6hr_Chicago	5:10	3.24
100yr_6hr_Chicago	5:20	3.1
100yr_6hr_Chicago	5:30	2.97
100yr_6hr_Chicago	5:40	2.85
100yr_6hr_Chicago	5:50	2.74
100yr_6hr_Chicago	6:00	2.64
100yr_6hr_Chicago_Increase_20percent	0:10	3.492
100yr_6hr_Chicago_Increase_20percent	0:20	3.804
100yr_6hr_Chicago_Increase_20percent	0:30	4.176
100yr_6hr_Chicago_Increase_20percent	0:40	4.656
100yr_6hr_Chicago_Increase_20percent	0:50	5.268
100yr_6hr_Chicago_Increase_20percent	1:00	6.096
100yr_6hr_Chicago_Increase_20percent	1:10	7.26
100yr_6hr_Chicago_Increase_20percent	1:20	9.06
100yr_6hr_Chicago_Increase_20percent	1:30	12.204
100yr_6hr_Chicago_Increase_20percent	1:40	19.176
100yr_6hr_Chicago_Increase_20percent	1:50	48.804
100yr_6hr_Chicago_Increase_20percent	2:00	214.272
100yr_6hr_Chicago_Increase_20percent	2:10	64.848
100yr_6hr_Chicago_Increase_20percent	2:20	32.772
100yr_6hr_Chicago_Increase_20percent	2:30	21.876

10yr_6hr_Chicago	3:30	4.458099842
10yr_6hr_Chicago	3:40	4.048999786
10yr_6hr_Chicago	3:50	3.713700056
10yr_6hr_Chicago	4:00	3.433599949
10yr_6hr_Chicago	4:10	3.195899963
10yr_6hr_Chicago	4:20	2.991600037
10yr_6hr_Chicago	4:30	2.813899994
10yr_6hr_Chicago	4:40	2.657799959
10yr_6hr_Chicago	4:50	2.51970005
10yr_6hr_Chicago	5:00	2.396399975
10yr_6hr_Chicago	5:10	2.285399947
10yr_6hr_Chicago	5:20	2.185600042
10yr_6hr_Chicago	5:30	2.094799995
10yr_6hr_Chicago	5:40	2.011899948
10yr_6hr_Chicago	5:50	1.935899973
10yr_6hr_Chicago	6:00	1.866000056
25mm_3hr_Chicago	0:10	2.208569887
25mm_3hr_Chicago	0:20	2.744979418
25mm_3hr_Chicago	0:30	3.677968081
25mm_3hr_Chicago	0:40	5.73933892
25mm_3hr_Chicago	0:50	12.24175103
25mm_3hr_Chicago	1:00	60.26760868
25mm_3hr_Chicago	1:10	18.89446976
25mm_3hr_Chicago	1:20	9.701668644
25mm_3hr_Chicago	1:30	6.531704893
25mm_3hr_Chicago	1:40	4.946173367
25mm_3hr_Chicago	1:50	3.997961752
25mm_3hr_Chicago	2:00	3.367311728
25mm_3hr_Chicago	2:10	2.917374438
25mm_3hr_Chicago	2:20	2.579725173
25mm_3hr_Chicago	2:30	2.316777817
25mm_3hr_Chicago	2:40	2.106011866
25mm_3hr_Chicago	2:50	1.933067571
25mm_3hr_Chicago	3:00	1.788450463
25mm_4hr_Chicago	0:10	1.390031032
25mm_4hr_Chicago	0:20	1.600567104
25mm_4hr_Chicago	0:30	1.896970739
25mm_4hr_Chicago	0:40	2.348512916
25mm_4hr_Chicago	0:50	3.128819406
25mm_4hr_Chicago	1:00	4.839380549
25mm_4hr_Chicago	1:10	12.24175103
25mm_4hr_Chicago	1:20	65.1393151
25mm_4hr_Chicago	1:30	16.32844304
25mm_4hr_Chicago	1:40	8.172359775
25mm_4hr_Chicago	1:50	5.505399744
25mm_4hr_Chicago	2:00	4.184927678
25mm_4hr_Chicago	2:10	3.395746228
25mm_4hr_Chicago	2:20	2.869710614
25mm_4hr_Chicago	2:30	2.493174451
25mm_4hr_Chicago	2:40	2.209779071
25mm_4hr_Chicago	2:50	1.988391448
25mm_4hr_Chicago	3:00	1.810366168
25mm_4hr_Chicago	3:10	1.663942474
25mm_4hr_Chicago	3:20	1.541228626
25mm_4hr_Chicago	3:30	1.436809662
25mm_4hr_Chicago	3:40	1.346776872
25mm_4hr_Chicago	3:50	1.268310404
25mm_4hr_Chicago	4:00	1.199259868
25yr_3hr_Chicago	0:10	4.933599949

100yr_6hr_Chicago_Increase_20percent	2:40	16.476
100yr_6hr_Chicago_Increase_20percent	2:50	13.26
100yr_6hr_Chicago_Increase_20percent	3:00	11.136
100yr_6hr_Chicago_Increase_20percent	3:10	9.624
100yr_6hr_Chicago_Increase_20percent	3:20	8.496
100yr_6hr_Chicago_Increase_20percent	3:30	7.608
100yr_6hr_Chicago_Increase_20percent	3:40	6.912
100yr_6hr_Chicago_Increase_20percent	3:50	6.336
100yr_6hr_Chicago_Increase_20percent	4:00	5.856
100yr_6hr_Chicago_Increase_20percent	4:10	5.448
100yr_6hr_Chicago_Increase_20percent	4:20	5.1
100yr_6hr_Chicago_Increase_20percent	4:30	4.788
100yr_6hr_Chicago_Increase_20percent	4:40	4.524
100yr_6hr_Chicago_Increase_20percent	4:50	4.284
100yr_6hr_Chicago_Increase_20percent	5:00	4.08
100yr_6hr_Chicago_Increase_20percent	5:10	3.888
100yr_6hr_Chicago_Increase_20percent	5:20	3.72
100yr_6hr_Chicago_Increase_20percent	5:30	3.564
100yr_6hr_Chicago_Increase_20percent	5:40	3.42
100yr_6hr_Chicago_Increase_20percent	5:50	3.288
100yr_6hr_Chicago_Increase_20percent	6:00	3.168
10yr_3hr_Chicago	0:10	4.248000145
10yr_3hr_Chicago	0:20	5.290299892
10yr_3hr_Chicago	0:30	7.108200073
10yr_3hr_Chicago	0:40	11.12989998
10yr_3hr_Chicago	0:50	28.09959984
10yr_3hr_Chicago	1:00	122.1417999
10yr_3hr_Chicago	1:10	37.28490067
10yr_3hr_Chicago	1:20	18.95369911
10yr_3hr_Chicago	1:30	12.69960022
10yr_3hr_Chicago	1:40	9.587599754
10yr_3hr_Chicago	1:50	7.732699871
10yr_3hr_Chicago	2:00	6.501999855
10yr_3hr_Chicago	2:10	5.625500202
10yr_3hr_Chicago	2:20	4.968900204
10yr_3hr_Chicago	2:30	4.458099842
10yr_3hr_Chicago	2:40	4.048999786
10yr_3hr_Chicago	2:50	3.713700056
10yr_3hr_Chicago	3:00	3.433599949
10yr_6hr_Chicago	0:10	2.050699949
10yr_6hr_Chicago	0:20	2.232800007
10yr_6hr_Chicago	0:30	2.454900026
10yr_6hr_Chicago	0:40	2.732300043
10yr_6hr_Chicago	0:50	3.089799881
10yr_6hr_Chicago	1:00	3.569000006
10yr_6hr_Chicago	1:10	4.248000145
10yr_6hr_Chicago	1:20	5.290299892
10yr_6hr_Chicago	1:30	7.108200073
10yr_6hr_Chicago	1:40	11.12989998
10yr_6hr_Chicago	1:50	28.09959984
10yr_6hr_Chicago	2:00	122.1417999
10yr_6hr_Chicago	2:10	37.28490067
10yr_6hr_Chicago	2:20	18.95369911
10yr_6hr_Chicago	2:30	12.69960022
10yr_6hr_Chicago	2:40	9.587599754
10yr_6hr_Chicago	2:50	7.732699871
10yr_6hr_Chicago	3:00	6.501999855
10yr_6hr_Chicago	3:10	5.625500202
10yr_6hr_Chicago	3:20	4.968900204

25yr_3hr_Chicago	0:20	6.152200222
25yr_3hr_Chicago	0:30	8.281599998
25yr_3hr_Chicago	0:40	13.00549984
25yr_3hr_Chicago	0:50	33.04079819
25yr_3hr_Chicago	1:00	144.6929932
25yr_3hr_Chicago	1:10	43.90420151
25yr_3hr_Chicago	1:20	22.2389984
25yr_3hr_Chicago	1:30	14.85159969
25yr_3hr_Chicago	1:40	11.19159985
25yr_3hr_Chicago	1:50	9.013699532
25yr_3hr_Chicago	2:00	7.570899963
25yr_3hr_Chicago	2:10	6.544300079
25yr_3hr_Chicago	2:20	5.776100159
25yr_3hr_Chicago	2:30	5.178999901
25yr_3hr_Chicago	2:40	4.701099873
25yr_3hr_Chicago	2:50	4.309599876
25yr_3hr_Chicago	3:00	3.982800007
25yr_6hr_Chicago	0:10	2.37229991
25yr_6hr_Chicago	0:20	2.584000111
25yr_6hr_Chicago	0:30	2.842400074
25yr_6hr_Chicago	0:40	3.165499926
25yr_6hr_Chicago	0:50	3.581899881
25yr_6hr_Chicago	1:00	4.140900135
25yr_6hr_Chicago	1:10	4.933599949
25yr_6hr_Chicago	1:20	6.152200222
25yr_6hr_Chicago	1:30	8.281599998
25yr_6hr_Chicago	1:40	13.00549984
25yr_6hr_Chicago	1:50	33.04079819
25yr_6hr_Chicago	2:00	144.6929932
25yr_6hr_Chicago	2:10	43.90420151
25yr_6hr_Chicago	2:20	22.2389984
25yr_6hr_Chicago	2:30	14.85159969
25yr_6hr_Chicago	2:40	11.19159985
25yr_6hr_Chicago	2:50	9.013699532
25yr_6hr_Chicago	3:00	7.570899963
25yr_6hr_Chicago	3:10	6.544300079
25yr_6hr_Chicago	3:20	5.776100159
25yr_6hr_Chicago	3:30	5.178999901
25yr_6hr_Chicago	3:40	4.701099873
25yr_6hr_Chicago	3:50	4.309599876
25yr_6hr_Chicago	4:00	3.982800007
25yr_6hr_Chicago	4:10	3.705699921
25yr_6hr_Chicago	4:20	3.467499971
25yr_6hr_Chicago	4:30	3.260400057
25yr_6hr_Chicago	4:40	3.078700066
25yr_6hr_Chicago	4:50	2.91779995
25yr_6hr_Chicago	5:00	2.774300098
25yr_6hr_Chicago	5:10	2.645499945
25yr_6hr_Chicago	5:20	2.529200077
25yr_6hr_Chicago	5:30	2.423500061
25yr_6hr_Chicago	5:40	2.327100039
25yr_6hr_Chicago	5:50	2.238800049
25yr_6hr_Chicago	6:00	2.157599926
2yr_3hr_Chicago	0:10	2.814599991
2yr_3hr_Chicago	0:20	3.49819994
2yr_3hr_Chicago	0:30	4.687200069
2yr_3hr_Chicago	0:40	7.304900169
2yr_3hr_Chicago	0:50	18.20879936
2yr_3hr_Chicago	1:00	76.80500031

2yr_3hr_Chicago	1:10	24.07909966
2yr_3hr_Chicago	1:20	12.36380005
2yr_3hr_Chicago	1:30	8.324000359
2yr_3hr_Chicago	1:40	6.30340004
2yr_3hr_Chicago	1:50	5.09499979
2yr_3hr_Chicago	2:00	4.29129982
2yr_3hr_Chicago	2:10	3.717990038
2yr_3hr_Chicago	2:20	3.28760004
2yr_3hr_Chicago	2:30	2.952500105
2yr_3hr_Chicago	2:40	2.683900118
2yr_3hr_Chicago	2:50	2.463500023
2yr_3hr_Chicago	3:00	2.279200077
2yr_6hr_Chicago	0:10	1.3671
2yr_6hr_Chicago	0:20	1.487400055
2yr_6hr_Chicago	0:30	1.63409996
2yr_6hr_Chicago	0:40	1.817199945
2yr_6hr_Chicago	0:50	2.05279994
2yr_6hr_Chicago	1:00	2.368299961
2yr_6hr_Chicago	1:10	2.814599991
2yr_6hr_Chicago	1:20	3.49819994
2yr_6hr_Chicago	1:30	4.687200069
2yr_6hr_Chicago	1:40	7.304900169
2yr_6hr_Chicago	1:50	18.20879936
2yr_6hr_Chicago	2:00	76.80500031
2yr_6hr_Chicago	2:10	24.07909966
2yr_6hr_Chicago	2:20	12.36380005
2yr_6hr_Chicago	2:30	8.324000359
2yr_6hr_Chicago	2:40	6.30340004
2yr_6hr_Chicago	2:50	5.09499979
2yr_6hr_Chicago	3:00	4.29129982
2yr_6hr_Chicago	3:10	3.717990038
2yr_6hr_Chicago	3:20	3.28760004
2yr_6hr_Chicago	3:30	2.952500105
2yr_6hr_Chicago	3:40	2.683900118
2yr_6hr_Chicago	3:50	2.463500023
2yr_6hr_Chicago	4:00	2.279200077
2yr_6hr_Chicago	4:10	2.122699976
2yr_6hr_Chicago	4:20	1.988100052
2yr_6hr_Chicago	4:30	1.871000051
2yr_6hr_Chicago	4:40	1.768000007
2yr_6hr_Chicago	4:50	1.676900029
2yr_6hr_Chicago	5:00	1.595499992
2yr_6hr_Chicago	5:10	1.522300005
2yr_6hr_Chicago	5:20	1.45630002
2yr_6hr_Chicago	5:30	1.396199942
2yr_6hr_Chicago	5:40	1.341400027
2yr_6hr_Chicago	5:50	1.291100025
2yr_6hr_Chicago	6:00	1.244899988
50yr_3hr_Chicago	0:10	5.467100143
50yr_3hr_Chicago	0:20	6.820400238
50yr_3hr_Chicago	0:30	9.186599731
50yr_3hr_Chicago	0:40	14.4406004
50yr_3hr_Chicago	0:50	36.7641983
50yr_3hr_Chicago	1:00	161.4707031
50yr_3hr_Chicago	1:10	48.87599945
50yr_3hr_Chicago	1:20	24.70429993
50yr_3hr_Chicago	1:30	16.49480057
50yr_3hr_Chicago	1:40	12.42230034
50yr_3hr_Chicago	1:50	10.00039959
50yr_3hr_Chicago	2:00	8.39659977
50yr_3hr_Chicago	2:10	7.256000042
50yr_3hr_Chicago	2:20	6.402599812
50yr_3hr_Chicago	2:30	5.739600182
50yr_3hr_Chicago	2:40	5.209000111
50yr_3hr_Chicago	2:50	4.774499893
50yr_3hr_Chicago	3:00	4.411799908
50yr_3hr_Chicago	3:10	4.104300022
50yr_3hr_Chicago	3:20	3.839999914
50yr_3hr_Chicago	3:30	3.610300064
50yr_3hr_Chicago	3:40	3.408799887
50yr_3hr_Chicago	3:50	3.23029995
50yr_3hr_Chicago	4:00	3.071199894
50yr_3hr_Chicago	4:10	2.92840004
50yr_3hr_Chicago	4:20	2.792400091
50yr_3hr_Chicago	4:30	2.682300091
50yr_3hr_Chicago	4:40	2.575400114
50yr_3hr_Chicago	4:50	2.477499962
50yr_3hr_Chicago	5:00	2.387500048
50yr_3hr_Chicago	5:10	3.682199955
50yr_3hr_Chicago	5:20	4.582300186
50yr_3hr_Chicago	5:30	6.150499821
50yr_3hr_Chicago	5:40	9.614100456
50yr_3hr_Chicago	5:50	24.17040062
50yr_3hr_Chicago	6:00	104.1930008
50yr_3hr_Chicago	0:10	32.03689957
50yr_3hr_Chicago	0:20	16.33749962
50yr_3hr_Chicago	0:30	10.96479988
50yr_3hr_Chicago	0:40	8.286899567
50yr_3hr_Chicago	0:50	6.68900013
50yr_3hr_Chicago	1:00	5.627900124
50yr_3hr_Chicago	1:10	4.87169981
50yr_3hr_Chicago	1:20	4.304800034
50yr_3hr_Chicago	1:30	3.863699913
50yr_3hr_Chicago	1:40	3.510299921
50yr_3hr_Chicago	1:50	3.220499992
50yr_3hr_Chicago	2:00	2.978300095
50yr_3hr_Chicago	2:10	2.772799969
50yr_3hr_Chicago	2:20	2.595999956
50yr_3hr_Chicago	2:30	2.442300081
50yr_3hr_Chicago	2:40	2.307199955
50yr_3hr_Chicago	2:50	2.187599997
50yr_3hr_Chicago	3:00	2.080899954
50yr_3hr_Chicago	3:10	1.985000014
50yr_3hr_Chicago	3:20	1.898399949
50yr_3hr_Chicago	3:30	1.819700003
50yr_3hr_Chicago	3:40	1.747900009
50yr_3hr_Chicago	3:50	1.682100058
50yr_3hr_Chicago	4:00	1.621500015

50yr_3hr_Chicago	2:00	8.39659977
50yr_3hr_Chicago	2:10	7.256000042
50yr_3hr_Chicago	2:20	6.402599812
50yr_3hr_Chicago	2:30	5.739600182
50yr_3hr_Chicago	2:40	5.209000111
50yr_3hr_Chicago	2:50	4.774499893
50yr_3hr_Chicago	3:00	4.411799908
50yr_6hr_Chicago	0:10	2.625499964
50yr_6hr_Chicago	0:20	2.860199928
50yr_6hr_Chicago	0:30	3.146699905
50yr_6hr_Chicago	0:40	3.505000114
50yr_6hr_Chicago	0:50	3.967000008
50yr_6hr_Chicago	1:00	4.587200165
50yr_6hr_Chicago	1:10	5.467100143
50yr_6hr_Chicago	1:20	6.820400238
50yr_6hr_Chicago	1:30	9.186599731
50yr_6hr_Chicago	1:40	14.4406004
50yr_6hr_Chicago	1:50	36.7641983
50yr_6hr_Chicago	2:00	161.4707031
50yr_6hr_Chicago	2:10	48.87599945
50yr_6hr_Chicago	2:20	24.70429993
50yr_6hr_Chicago	2:30	16.49480057
50yr_6hr_Chicago	2:40	12.42230034
50yr_6hr_Chicago	2:50	10.00039959
50yr_6hr_Chicago	3:00	8.39659977
50yr_6hr_Chicago	3:10	7.256000042
50yr_6hr_Chicago	3:20	6.402599812
50yr_6hr_Chicago	3:30	5.739600182
50yr_6hr_Chicago	3:40	5.209000111
50yr_6hr_Chicago	3:50	4.774499893
50yr_6hr_Chicago	4:00	4.411799908
50yr_6hr_Chicago	4:10	4.104300022
50yr_6hr_Chicago	4:20	3.839999914
50yr_6hr_Chicago	4:30	3.610300064
50yr_6hr_Chicago	4:40	3.408799887
50yr_6hr_Chicago	4:50	3.23029995
50yr_6hr_Chicago	5:00	3.071199894
50yr_6hr_Chicago	5:10	2.92840004
50yr_6hr_Chicago	5:20	2.792400091
50yr_6hr_Chicago	5:30	2.682300091
50yr_6hr_Chicago	5:40	2.575400114
50yr_6hr_Chicago	5:50	2.477499962
50yr_6hr_Chicago	6:00	2.387500048
5yr_3hr_Chicago	0:10	3.682199955
5yr_3hr_Chicago	0:20	4.582300186
5yr_3hr_Chicago	0:30	6.150499821
5yr_3hr_Chicago	0:40	9.614100456
5yr_3hr_Chicago	0:50	24.17040062
5yr_3hr_Chicago	1:00	104.1930008
5yr_3hr_Chicago	1:10	32.03689957
5yr_3hr_Chicago	1:20	16.33749962
5yr_3hr_Chicago	1:30	10.96479988
5yr_3hr_Chicago	1:40	8.286899567
5yr_3hr_Chicago	1:50	6.68900013
5yr_3hr_Chicago	2:00	5.627900124
5yr_3hr_Chicago	2:10	4.87169981
5yr_3hr_Chicago	2:20	4.304800034
5yr_3hr_Chicago	2:30	3.863699913
5yr_3hr_Chicago	2:40	3.510299921
5yr_3hr_Chicago	2:50	3.220499992
5yr_3hr_Chicago	3:00	2.978300095
5yr_3hr_Chicago	3:10	2.772799969
5yr_3hr_Chicago	3:20	2.595999956
5yr_3hr_Chicago	3:30	2.442300081
5yr_3hr_Chicago	3:40	2.307199955
5yr_3hr_Chicago	3:50	2.187599997
5yr_3hr_Chicago	4:00	2.080899954
5yr_3hr_Chicago	4:10	1.985000014
5yr_3hr_Chicago	4:20	1.898399949
5yr_3hr_Chicago	4:30	1.819700003
5yr_3hr_Chicago	4:40	1.747900009
5yr_3hr_Chicago	4:50	1.682100058
5yr_3hr_Chicago	5:00	1.621500015
5yr_3hr_Chicago	5:10	3.682199955
5yr_3hr_Chicago	5:20	4.582300186
5yr_3hr_Chicago	5:30	6.150499821
5yr_3hr_Chicago	5:40	9.614100456
5yr_3hr_Chicago	5:50	24.17040062
5yr_3hr_Chicago	6:00	104.1930008

5yr_3hr_Chicago	2:50	3.220499992
5yr_3hr_Chicago	3:00	2.978300095
5yr_6hr_Chicago	0:10	1.781599998
5yr_6hr_Chicago	0:20	1.939299941
5yr_6hr_Chicago	0:30	2.131500006
5yr_6hr_Chicago	0:40	2.371700048
5yr_6hr_Chicago	0:50	2.680900097
5yr_6hr_Chicago	1:00	3.095400095
5yr_6hr_Chicago	1:10	3.682199955
5yr_6hr_Chicago	1:20	4.582300186
5yr_6hr_Chicago	1:30	6.150499821
5yr_6hr_Chicago	1:40	9.614100456
5yr_6hr_Chicago	1:50	24.17040062
5yr_6hr_Chicago	2:00	104.1930008
5yr_6hr_Chicago	2:10	32.03689957
5yr_6hr_Chicago	2:20	16.33749962
5yr_6hr_Chicago	2:30	10.96479988
5yr_6hr_Chicago	2:40	8.286899567
5yr_6hr_Chicago	2:50	6.68900013
5yr_6hr_Chicago	3:00	5.627900124
5yr_6hr_Chicago	3:10	4.87169981
5yr_6hr_Chicago	3:20	4.304800034
5yr_6hr_Chicago	3:30	3.863699913
5yr_6hr_Chicago	3:40	3.510299921
5yr_6hr_Chicago	3:50	3.220499992
5yr_6hr_Chicago	4:00	2.978300095
5yr_6hr_Chicago	4:10	2.772799969
5yr_6hr_Chicago	4:20	2.595999956
5yr_6hr_Chicago	4:30	2.442300081
5yr_6hr_Chicago	4:40	2.307199955
5yr_6hr_Chicago	4:50	2.187599997
5yr_6hr_Chicago	5:00	2.080899954
5yr_6hr_Chicago	5:10	1.985000014
5yr_6hr_Chicago	5:20	1.898399949
5yr_6hr_Chicago	5:30	1.819700003
5yr_6hr_Chicago	5:40	1.747900009
5yr_6hr_Chicago	5:50	1.682100058
5yr_6hr_Chicago	6:00	1.621500015
;Rainfall (mm/hr)		
Chicago_3h	07/23/2009 00:01:00	4.812
Chicago_3h	07/23/2009 00:06:00	5.093
Chicago_3h	07/23/2009 00:11:00	5.419
Chicago_3h	07/23/2009 00:16:00	5.803
Chicago_3h	07/23/2009 00:21:00	6.264
Chicago_3h	07/23/2009 00:26:00	6.831
Chicago_3h	07/23/2009 00:31:00	7.549
Chicago_3h	07/23/2009 00:36:00	8.494
Chicago_3h	07/23/2009 00:41:00	9.811
Chicago_3h	07/23/2009 00:46:00	11.81
Chicago_3h	07/23/2009 00:51:00	15.336
Chicago_3h	07/23/2009 00:56:00	24.362
Chicago_3h	07/23/2009 01:01:00	142.91
Chicago_3h	07/23/2009 01:06:00	38.247
Chicago_3h	07/23/2009 01:11:00	24.639
Chicago_3h	07/23/2009 01:16:00	18.532
Chicago_3h	07/23/2009 01:21:00	15.221
Chicago_3h	07/23/2009 01:26:00	13.09
Chicago_3h	07/23/2009 01:31:00	11.582
Chicago_3h	07/23/2009 01:36:00	10.448

Chicago_3h	07/23/2009 01:41:00	9.558
Chicago_3h	07/23/2009 01:46:00	8.838
Chicago_3h	07/23/2009 01:51:00	8.241
Chicago_3h	07/23/2009 01:56:00	7.736
Chicago_3h	07/23/2009 02:01:00	7.303
Chicago_3h	07/23/2009 02:06:00	6.926
Chicago_3h	07/23/2009 02:11:00	6.594
Chicago_3h	07/23/2009 02:16:00	6.3
Chicago_3h	07/23/2009 02:21:00	6.037
Chicago_3h	07/23/2009 02:26:00	5.801
Chicago_3h	07/23/2009 02:31:00	5.586
Chicago_3h	07/23/2009 02:36:00	5.39
Chicago_3h	07/23/2009 02:41:00	5.211
Chicago_3h	07/23/2009 02:46:00	5.046
Chicago_3h	07/23/2009 02:51:00	4.893
Chicago_3h	07/23/2009 02:56:00	4.752
Chicago_3h	07/23/2009 03:01:00	0
;Rainfall (mm/hr)		
Chicago_6h100-yr	07/23/2009 00:01:00	2.702
Chicago_6h100-yr	07/23/2009 00:06:00	2.802
Chicago_6h100-yr	07/23/2009 00:11:00	2.91
Chicago_6h100-yr	07/23/2009 00:16:00	3.028
Chicago_6h100-yr	07/23/2009 00:21:00	3.157
Chicago_6h100-yr	07/23/2009 00:26:00	3.299
Chicago_6h100-yr	07/23/2009 00:31:00	3.455
Chicago_6h100-yr	07/23/2009 00:36:00	3.629
Chicago_6h100-yr	07/23/2009 00:41:00	3.823
Chicago_6h100-yr	07/23/2009 00:46:00	4.042
Chicago_6h100-yr	07/23/2009 00:51:00	4.29
Chicago_6h100-yr	07/23/2009 00:56:00	4.574
Chicago_6h100-yr	07/23/2009 01:01:00	4.903
Chicago_6h100-yr	07/23/2009 01:06:00	5.288
Chicago_6h100-yr	07/23/2009 01:11:00	5.745
Chicago_6h100-yr	07/23/2009 01:16:00	6.298
Chicago_6h100-yr	07/23	

```

Chicago_6h100-yr 07/23/2009 03:31:00 6.538
Chicago_6h100-yr 07/23/2009 03:36:00 6.202
Chicago_6h100-yr 07/23/2009 03:41:00 5.9
Chicago_6h100-yr 07/23/2009 03:46:00 5.629
Chicago_6h100-yr 07/23/2009 03:51:00 5.384
Chicago_6h100-yr 07/23/2009 03:56:00 5.16
Chicago_6h100-yr 07/23/2009 04:01:00 4.956
Chicago_6h100-yr 07/23/2009 04:06:00 4.769
Chicago_6h100-yr 07/23/2009 04:11:00 4.596
Chicago_6h100-yr 07/23/2009 04:16:00 4.437
Chicago_6h100-yr 07/23/2009 04:21:00 4.289
Chicago_6h100-yr 07/23/2009 04:26:00 4.152
Chicago_6h100-yr 07/23/2009 04:31:00 4.024
Chicago_6h100-yr 07/23/2009 04:36:00 3.904
Chicago_6h100-yr 07/23/2009 04:41:00 3.791
Chicago_6h100-yr 07/23/2009 04:46:00 3.686
Chicago_6h100-yr 07/23/2009 04:51:00 3.587
Chicago_6h100-yr 07/23/2009 04:56:00 3.493
Chicago_6h100-yr 07/23/2009 05:01:00 3.405
Chicago_6h100-yr 07/23/2009 05:06:00 3.321
Chicago_6h100-yr 07/23/2009 05:11:00 3.242
Chicago_6h100-yr 07/23/2009 05:16:00 3.167
Chicago_6h100-yr 07/23/2009 05:21:00 3.096
Chicago_6h100-yr 07/23/2009 05:26:00 3.028
Chicago_6h100-yr 07/23/2009 05:31:00 2.963
Chicago_6h100-yr 07/23/2009 05:36:00 2.901
Chicago_6h100-yr 07/23/2009 05:41:00 2.842
Chicago_6h100-yr 07/23/2009 05:46:00 2.786
Chicago_6h100-yr 07/23/2009 05:51:00 2.732
Chicago_6h100-yr 07/23/2009 05:56:00 2.68
Chicago_6h100-yr 07/23/2009 06:01:00 0

```

```

;Flow (m³/s)
Overland_flow_hydrograph 07/23/2009 00:01:00 0
Overland_flow_hydrograph 07/23/2009 00:02:00 0
Overland_flow_hydrograph 07/23/2009 00:03:00 0
Overland_flow_hydrograph 07/23/2009 00:04:00 0
Overland_flow_hydrograph 07/23/2009 00:05:00 0
Overland_flow_hydrograph 07/23/2009 00:06:00 0
Overland_flow_hydrograph 07/23/2009 00:07:00 0
Overland_flow_hydrograph 07/23/2009 00:08:00 0
Overland_flow_hydrograph 07/23/2009 00:09:00 0
Overland_flow_hydrograph 07/23/2009 00:10:00 0
Overland_flow_hydrograph 07/23/2009 00:11:00 0
.....
Too many data points (1124 in total).

```

```

[REPORT]
;;Reporting Options
INPUP YES
CONTROLS NO
SUBCATCHMENTS ALL
NODES ALL
LINKS ALL

[TAGS]
Subcatch A-1 Uncontrolled
Subcatch A-10 Controlled
Subcatch A-11 Controlled
Subcatch A-12 Controlled
Subcatch A-13 Controlled
Subcatch A-14 Controlled

```

```

Subcatch A-15 Controlled
Subcatch A-16 Controlled
Subcatch A-17 Controlled
Subcatch A-18 Controlled
Subcatch A-19 Uncontrolled
Subcatch A-20 Controlled
Subcatch A-21 Controlled
Subcatch A-22 Controlled
Subcatch A-23 Controlled
Subcatch A-4 Controlled
Subcatch A-5 Uncontrolled
Subcatch A-6 Controlled
Subcatch A-7 Controlled
Subcatch A-8 Controlled
Subcatch A-9 Controlled
Subcatch R-1 Controlled
Subcatch R-2 Uncontrolled

```

```

[MAP]
DIMENSIONS 371085.4846 5029471.83825 371318.3414
5029686.39875
UNITS Meters

```

```

[COORDINATES]
;;Node X-Coord Y-Coord
-----
CB10 371143.951 5029625.822
CB1CONNECT 371302.87 5029623.087
CBMH108 371167.027 5029649.718
BFM04 371164.133 5029645.764
EFTM06 371129.636 5029639.839
EXSTMH01 371154.133 5029647.736
EXSTMH02 371262.634 5029657.842
MH-ST2210 371299.831 5029640.854
ROOF 371264.245 5029650.616
STMH102 371164.314 5029626.61
STMH106 371296.09 5029659.322
STMH108 371177.898 5029598.214
STMH109 371226.938 5029544.597
STMH114 371187.773 5029649.718
OF1 371260.667 5029676.646
OF2 371157.5 5029676.12
CB07 371300.23 5029616.274
CB1 371221.178 5029538.33
CB12 371172.465 5029634.703
CB13 371119.866 5029633.223
CB14 371141.716 5029651.306
CB15 371198.73 5029649.796
CB2 371182.26 5029578.07
CB20 371246.592 5029521.94
CB3 371196.041 5029591.991
CB4 371158.529 5029581.474
CB5 371181.545 5029609.457
CB6 371164.401 5029594.446
CB8 371145.587 5029609.871
EXCB02 371198.775 5029549.905
MCT200 371182.243 5029631.723
Pond1 371111.789 5029632.105
Pond2 371106.59 5029657.922
R1 371224.985 5029633.329

```

```

[VERTICES]

```

```

;;Link X-Coord Y-Coord
-----
[POLYGONS]
;;Subcatchment X-Coord Y-Coord
-----
A-1 371297.429 5029625.175
A-1 371288.185 5029623.324
A-1 371288.587 5029619.945
A-1 371286.521 5029619.733
A-1 371287.954 5029608.594
A-1 371282.95 5029607.299
A-1 371278.961 5029623.025
A-1 371277.916 5029627.144
A-1 371285.377 5029628.291
A-1 371282.614 5029649.864
A-1 371294.296 5029651.664
A-1 371297.753 5029632.159
A-1 371298.501 5029629.448
A-1 371299.623 5029625.708
A-1 371300.464 5029623.184
A-1 371302.615 5029616.265
A-1 371305.513 5029605.513
A-1 371307.757 5029598.876
A-1 371304.003 5029603.656
A-1 371297.429 5029625.175
A-10 371154.536 5029638.735
A-10 371161.287 5029639.62
A-10 371163.5 5029639.906
A-10 371169.268 5029640.632
A-10 371170.711 5029628.659
A-10 371173.191 5029623.644
A-10 371170.782 5029623.34
A-10 371156.718 5029621.598
A-10 371156.248 5029625.675
A-10 371154.536 5029638.735
A-11 371196.569 5029626.783
A-11 371195.13 5029626.551
A-11 371188.397 5029625.715
A-11 371186.926 5029625.514
A-11 371173.191 5029623.644
A-11 371169.268 5029640.632
A-11 371182.249 5029642.265
A-11 371195.172 5029638.635
A-11 371196.458 5029638.924
A-11 371197.861 5029627.068
A-11 371196.569 5029626.783
A-12 371214.519 5029619.087
A-12 371215.445 5029619.145
A-12 371216.487 5029610.869
A-12 371207.111 5029606.296
A-12 371193.337 5029599.641
A-12 371184.518 5029591.117
A-12 371173.12 5029605.558
A-12 371165.373 5029611.817
A-12 371169.051 5029615.485
A-12 371173.191 5029623.644
A-12 371186.926 5029625.514
A-12 371188.397 5029625.715
A-12 371195.13 5029626.551

```

```

A-12 371196.569 5029626.783
A-12 371197.861 5029627.068
A-12 371198.381 5029622.463
A-12 371207.914 5029623.623
A-12 371213.863 5029624.439
A-12 371214.519 5029619.087
A-13 371171.738 5029579.046
A-13 371157.097 5029594.579
A-13 371155.814 5029595.845
A-13 371155.324 5029596.392
A-13 371154.651 5029597.145
A-13 371156.667 5029599.119
A-13 371158.255 5029600.811
A-13 371158.131 5029601.751
A-13 371156.751 5029603.632
A-13 371165.373 5029611.817
A-13 371171.12 5029605.558
A-13 371184.518 5029591.117
A-13 371171.738 5029579.046
A-14 371216.487 5029610.869
A-14 371217.508 5029602.358
A-14 371210.954 5029600.457
A-14 371216.734 5029577.929
A-14 371206.125 5029567.967
A-14 371203.459 5029578.841
A-14 371203.388 5029580.036
A-14 371202.545 5029580.528
A-14 371201.491 5029580.247
A-14 371200.296 5029579.192
A-14 371197.912 5029577.083
A-14 371184.518 5029591.117
A-14 371193.337 5029599.641
A-14 371207.111 5029606.296
A-14 371216.487 5029610.869
A-15 371197.912 5029577.083
A-15 371200.296 5029579.192
A-15 371201.491 5029580.247
A-15 371202.545 5029580.528
A-15 371203.388 5029580.036
A-15 371203.459 5029578.841
A-15 371206.125 5029567.967
A-15 371204.647 5029566.612
A-15 371197.009 5029559.303
A-15 371188.635 5029561.107
A-15 371177.863 5029572.662
A-15 371175.115 5029575.464
A-15 371171.738 5029579.046
A-15 371184.518 5029591.117
A-15 371197.912 5029577.083
A-15 371213.253 5029563.642
A-16 371212.009 5029550.694
A-16 371199.506 5029533.684
A-16 371183.342 5029550.858
A-16 371188.635 5029561.107
A-16 371197.009 5029559.303
A-16 371204.647 5029566.612
A-16 371206.125 5029567.967
A-16 371216.734 5029577.929
A-16 371221.906 5029579.166
A-16 371225.463 5029575.384
A-16 371213.253 5029563.642

```

A-17 371242.294 5029546.704
A-17 371232.6 5029521.49
A-17 371218.179 5029524.15
A-17 371213.096 5029519.358
A-17 371199.506 5029533.684
A-17 371212.009 5029550.694
A-17 371213.253 5029566.642
A-17 371225.463 5029575.384
A-17 371234.418 5029565.789
A-17 371232.459 5029563.907
A-17 371236.568 5029559.453
A-17 371235.132 5029554.191
A-17 371243.665 5029551.495
A-17 371242.294 5029546.704
A-18 371279.559 5029512.509
A-18 371260.274 5029494.124
A-18 371257.497 5029491.179
A-18 371262.58 5029485.416
A-18 371258.658 5029481.591
A-18 371254.884 5029485.064
A-18 371253.606 5029486.787
A-18 371246.156 5029494.347
A-18 371242.968 5029502.152
A-18 371233.334 5029512.648
A-18 371236.431 5029515.586
A-18 371237.98 5029517.055
A-18 371233.927 5029521.172
A-18 371233.648 5029521.376
A-18 371233.465 5029521.43
A-18 371232.908 5029521.505
A-18 371232.6 5029521.49
A-18 371242.151 5029546.539
A-18 371250.717 5029543.981
A-18 371249.301 5029539.048
A-18 371258.767 5029536.111
A-18 371260.693 5029538.1
A-18 371268.618 5029529.67
A-18 371266.838 5029525.479
A-18 371266.544 5029524.502
A-18 371269.347 5029523.701
A-18 371268.146 5029519.609
A-18 371275.527 5029517.392
A-18 371279.559 5029512.509
A-19 371218.179 5029524.15
A-19 371232.6 5029521.49
A-19 371232.908 5029521.505
A-19 371233.465 5029521.43
A-19 371233.648 5029521.376
A-19 371233.927 5029521.172
A-19 371237.98 5029517.055
A-19 371236.431 5029515.586
A-19 371233.334 5029512.648
A-19 371242.968 5029502.152
A-19 371246.156 5029494.347
A-19 371239.287 5029501.93
A-19 371234.14 5029506.993
A-19 371231.036 5029510.468
A-19 371218.179 5029524.15
A-20 371166.916 5029568.185
A-20 371149.288 5029586.937
A-20 371157.097 5029594.579

A-20 371165.415 5029585.755
A-20 371171.738 5029579.046
A-20 371175.115 5029575.464
A-20 371177.863 5029572.662
A-20 371188.635 5029561.107
A-20 371183.342 5029550.858
A-20 371166.916 5029568.185
A-21 371156.737 5029621.566
A-21 371173.191 5029623.644
A-21 371169.051 5029615.485
A-21 371165.373 5029611.817
A-21 371156.751 5029603.632
A-21 371158.13 5029601.751
A-21 371158.255 5029600.811
A-21 371156.667 5029599.119
A-21 371154.651 5029597.145
A-21 371155.324 5029596.392
A-21 371157.097 5029594.579
A-21 371149.288 5029586.937
A-21 371129.414 5029607.963
A-21 371141.147 5029619.569
A-21 371146.586 5029620.176
A-21 371152.595 5029621.092
A-21 371156.737 5029621.566
A-22 371129.414 5029607.963
A-22 371121.083 5029616.82
A-22 371123.521 5029618.559
A-22 371123.662 5029618.66
A-22 371121.821 5029620.624
A-22 371119.836 5029625.486
A-22 371119.225 5029629.185
A-22 371119.189 5029638.079
A-22 371119.428 5029652.873
A-22 371131.341 5029652.998
A-22 371132.453 5029645.104
A-22 371133.396 5029637.485
A-22 371134.028 5029632.372
A-22 371134.881 5029626.99
A-22 371137.747 5029627.379
A-22 371138.446 5029627.501
A-22 371139.203 5029627.538
A-22 371139.738 5029627.243
A-22 371140.052 5029626.874
A-22 371141.147 5029619.569
A-22 371129.414 5029607.963
A-23 371304.003 5029603.656
A-23 371307.757 5029598.876
A-23 371282.172 5029574.75
A-23 371272.3 5029579.133
A-23 371268.328 5029583.446
A-23 371266.328 5029590.786
A-23 371272.502 5029592.438
A-23 371277.245 5029593.007
A-23 371285.839 5029596.007
A-23 371282.95 5029607.299
A-23 371287.954 5029608.594
A-23 371286.521 5029619.733
A-23 371288.587 5029619.945
A-23 371288.185 5029623.324
A-23 371297.429 5029625.175
A-23 371304.003 5029603.656

A-4 371237.242 5029645.6
A-4 371218.849 5029643.243
A-4 371211.746 5029642.357
A-4 371213.208 5029629.786
A-4 371213.863 5029624.439
A-4 371207.914 5029623.623
A-4 371198.381 5029622.463
A-4 371197.861 5029627.068
A-4 371196.458 5029638.924
A-4 371195.172 5029638.635
A-4 371193.815 5029641.12
A-4 371197.83 5029649.383
A-4 371197.816 5029654.475
A-4 371197.879 5029655.649
A-4 371202.188 5029655.589
A-4 371211.51 5029655.689
A-4 371216.979 5029655.994
A-4 371228.133 5029656.352
A-4 371242.905 5029657.363
A-4 371258.78 5029659.71
A-4 371267.082 5029660.702
A-4 371286.385 5029662.948
A-4 371293.062 5029663.137
A-4 371294.296 5029651.664
A-4 371282.614 5029649.864
A-4 371282.432 5029651.39
A-4 371260.305 5029648.555
A-4 371237.242 5029645.6
A-5 371130.053 5029653.889
A-5 371130.006 5029656.188
A-5 371130.029 5029657.87
A-5 371129.935 5029660.762
A-5 371130.219 5029662.777
A-5 371130.48 5029664.175
A-5 371130.646 5029664.933
A-5 371131.285 5029665.455
A-5 371131.961 5029666.355
A-5 371132.322 5029666.434
A-5 371177.768 5029657.298
A-5 371193.615 5029655.612
A-5 371197.879 5029655.649
A-5 371197.816 5029654.475
A-5 371197.83 5029649.383
A-5 371193.815 5029649.132
A-5 371187.309 5029648.256
A-5 371187.014 5029648.278
A-5 371186.743 5029648.434
A-5 371186.544 5029648.701
A-5 371186.467 5029649.006
A-5 371186.513 5029649.312
A-5 371187.175 5029653.966
A-5 371140.645 5029660.633
A-5 371139.888 5029655.377
A-5 371138.614 5029655.202
A-5 371137.811 5029655.102
A-5 371137.536 5029655.056
A-5 371137.228 5029654.938
A-5 371136.972 5029654.755
A-5 371136.767 5029654.559
A-5 371136.642 5029654.327
A-5 371136.55 5029654.053

A-5 371136.532 5029653.721
A-5 371131.341 5029652.998
A-5 371130.004 5029652.984
A-5 371130.053 5029653.889
A-6 371119.384 5029652.907
A-6 371119.428 5029652.873
A-6 371119.362 5029652.872
A-6 371119.189 5029638.079
A-6 371119.225 5029629.185
A-6 371119.836 5029625.486
A-6 371121.821 5029620.624
A-6 371123.521 5029618.559
A-6 371121.083 5029616.82
A-6 371098.562 5029640.669
A-6 371097.636 5029650.257
A-6 371096.069 5029665.272
A-6 371119.515 5029667.9
A-6 371121.51 5029668.191
A-6 371126.513 5029667.441
A-6 371132.322 5029666.434
A-6 371131.285 5029665.455
A-6 371130.646 5029664.933
A-6 371130.448 5029664.175
A-6 371130.219 5029662.777
A-6 371129.935 5029660.762
A-6 371130.029 5029657.87
A-6 371130.006 5029656.188
A-6 371130.053 5029653.889
A-6 371130.004 5029652.984
A-6 371119.384 5029652.907
A-7 371163.919 5029657.298
A-7 371162.113 5029645.248
A-7 371161.381 5029640.193
A-7 371161.287 5029639.62
A-7 371145.547 5029637.556
A-7 371133.396 5029637.485
A-7 371132.453 5029645.104
A-7 371131.341 5029652.998
A-7 371136.532 5029653.721
A-7 371136.55 5029654.053
A-7 371136.642 5029654.327
A-7 371136.767 5029654.559
A-7 371136.972 5029654.755
A-7 371137.228 5029654.938
A-7 371137.536 5029655.056
A-7 371137.811 5029655.102
A-7 371138.614 5029655.202
A-7 371139.888 5029655.377
A-7 371140.645 5029660.633
A-7 371163.919 5029657.298
A-8 371163.919 5029657.298
A-8 371187.175 5029653.966
A-8 371186.513 5029649.312
A-8 371186.467 5029649.006
A-8 371186.544 5029648.701
A-8 371186.743 5029648.434
A-8 371187.014 5029648.278
A-8 371187.309 5029648.256
A-8 371193.815 5029649.12
A-8 371195.172 5029638.635
A-8 371182.249 5029642.265

A-8	371163.5	5029639.906
A-8	371161.287	5029639.62
A-8	371161.381	5029640.183
A-8	371162.113	5029645.248
A-8	371163.919	5029657.298
A-9	371156.248	5029625.675
A-9	371156.718	5029621.598
A-9	371152.595	5029621.092
A-9	371146.586	5029620.176
A-9	371141.147	5029619.569
A-9	371140.052	5029626.874
A-9	371139.738	5029627.243
A-9	371139.203	5029627.538
A-9	371138.446	5029627.501
A-9	371137.747	5029627.379
A-9	371134.881	5029626.99
A-9	371134.028	5029632.372
A-9	371133.396	5029637.485
A-9	371145.547	5029637.556
A-9	371154.536	5029638.735
A-9	371156.248	5029625.675
R-1	371266.328	5029590.786
R-1	371221.906	5029579.166
R-1	371216.734	5029577.929
R-1	371210.954	5029600.457
R-1	371217.508	5029602.358
R-1	371216.487	5029610.869
R-1	371215.445	5029619.145
R-1	371214.519	5029619.087
R-1	371213.208	5029629.786
R-1	371211.746	5029642.357
R-1	371218.849	5029643.243
R-1	371282.432	5029651.39
R-1	371282.614	5029649.864
R-1	371285.377	5029628.291
R-1	371277.916	5029627.144
R-1	371285.839	5029596.007
R-1	371266.328	5029590.786
R-2	371248.051	5029555.799
R-2	371269.925	5029532.086
R-2	371268.618	5029529.67
R-2	371260.693	5029538.1
R-2	371258.767	5029536.111
R-2	371249.301	5029539.048
R-2	371250.717	5029543.981
R-2	371242.294	5029546.704
R-2	371243.665	5029551.495
R-2	371235.132	5029554.191
R-2	371236.568	5029559.453
R-2	371232.459	5029563.907
R-2	371234.418	5029565.789
R-2	371228.522	5029572.131
R-2	371221.906	5029579.166
R-2	371266.328	5029590.786
R-2	371268.328	5029583.446
R-2	371272.3	5029579.133
R-2	371248.051	5029555.799

[SYMBOLS]

;;Gage X-Coord Y-Coord

;;-----

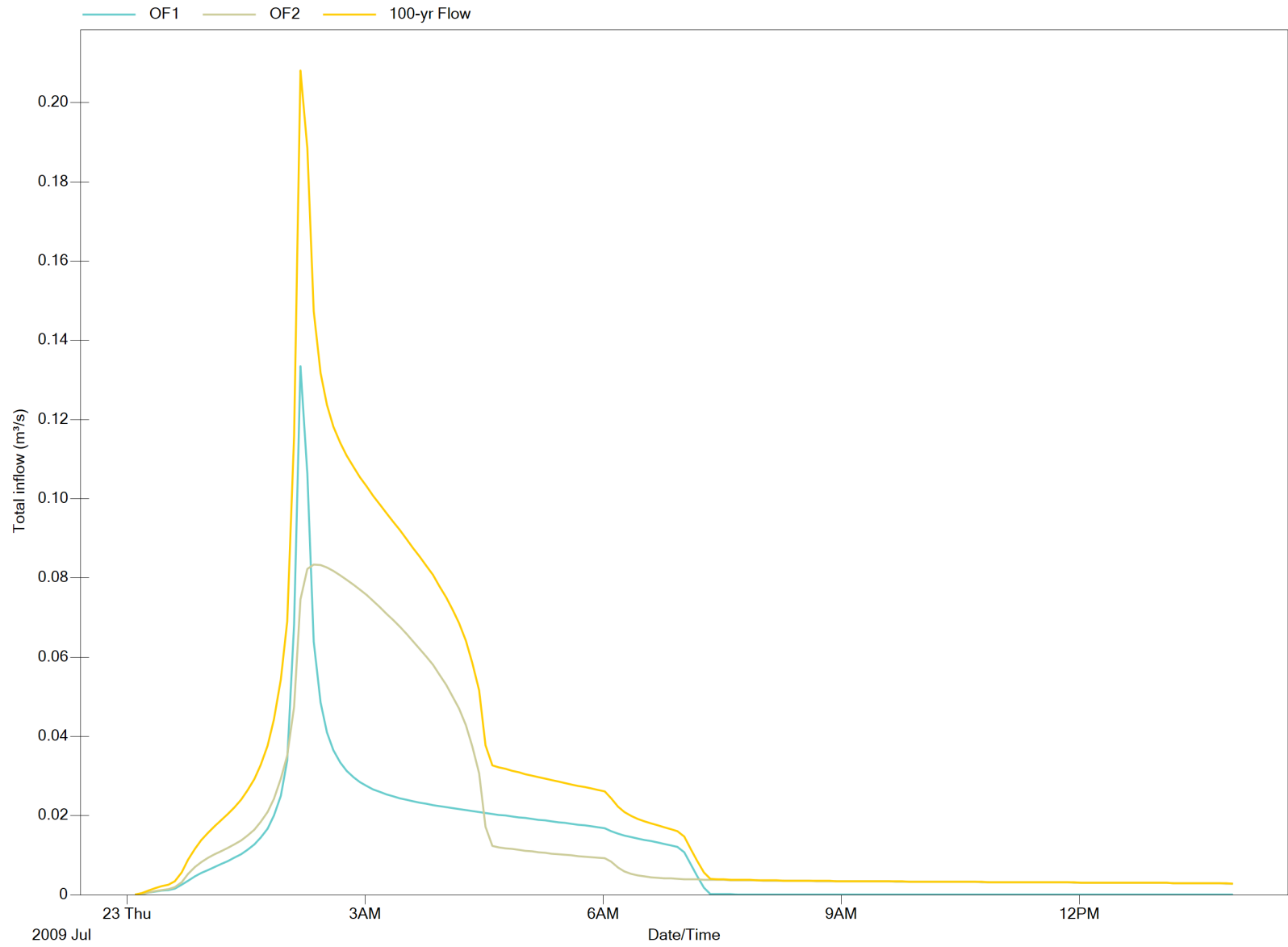

APPENDIX

C SUPPORTING DOCUMENTS



PROJECT INFORMATION	
ENGINEERED PRODUCT MANAGER:	HAIDER NASRULLAH 647-850-9417 HAIDER.NASRULLAH@ADSPIPE.COM
ADS SALES REP:	RYAN MARTIN 705-207-3059 RYAN.MARTIN@ADSPIPE.COM
PROJECT NO:	S381206
ONTARIO SITE COORDINATOR:	RYAN RUBENSTEIN 519-710-3687 RYAN.RUBENSTEIN@ADSPIPE.COM



U OTTAWA ADVANCED MEDICAL RESEARCH CTR

OTTAWA, ON.

MC-7200 STORMTECH CHAMBER SPECIFICATIONS

- CHAMBERS SHALL BE STORMTECH MC-7200.
- CHAMBERS SHALL BE ARCH-SHAPED AND SHALL BE MANUFACTURED FROM VIRGIN, IMPACT-MODIFIED POLYPROPYLENE COPOLYMERS.
- CHAMBERS SHALL BE CERTIFIED TO CSA B184, "POLYMERIC SUB-SURFACE STORMWATER MANAGEMENT STRUCTURES", AND MEET THE REQUIREMENTS OF ASTM F2418, "STANDARD SPECIFICATION FOR POLYPROPYLENE (PP) CORRUGATED WALL STORMWATER COLLECTION CHAMBERS" CHAMBER CLASSIFICATION 60x101.
- CHAMBER ROWS SHALL PROVIDE CONTINUOUS, UNOBSTRUCTED INTERNAL SPACE WITH NO INTERNAL SUPPORTS THAT WOULD IMPEDE FLOW OR LIMIT ACCESS FOR INSPECTION.
- THE STRUCTURAL DESIGN OF THE CHAMBERS, THE STRUCTURAL BACKFILL, AND THE INSTALLATION REQUIREMENTS SHALL ENSURE THAT THE LOAD FACTORS SPECIFIED IN THE AASHTO LRFD BRIDGE DESIGN SPECIFICATIONS, SECTION 12.12, ARE MET FOR: 1) LONG-DURATION DEAD LOADS AND 2) SHORT-DURATION LIVE LOADS, BASED ON THE CSA S6 CL-625 TRUCK AND THE AASHTO DESIGN TRUCK WITH CONSIDERATION FOR IMPACT AND MULTIPLE VEHICLE PRESENCES.
- CHAMBERS SHALL BE DESIGNED, TESTED AND ALLOWABLE LOAD CONFIGURATIONS DETERMINED IN ACCORDANCE WITH ASTM F2787, "STANDARD PRACTICE FOR STRUCTURAL DESIGN OF THERMOPLASTIC CORRUGATED WALL STORMWATER COLLECTION CHAMBERS". LOAD CONFIGURATIONS SHALL INCLUDE: 1) INSTANTANEOUS (<1 MIN) AASHTO DESIGN TRUCK LIVE LOAD ON MINIMUM COVER 2) MAXIMUM PERMANENT (75-YR) COVER LOAD AND 3) ALLOWABLE COVER WITH PARKED (1-WEEK) AASHTO DESIGN TRUCK.
- REQUIREMENTS FOR HANDLING AND INSTALLATION:
 - TO MAINTAIN THE WIDTH OF CHAMBERS DURING SHIPPING AND HANDLING, CHAMBERS SHALL HAVE INTEGRAL, INTERLOCKING STACKING LUGS.
 - TO ENSURE A SECURE JOINT DURING INSTALLATION AND BACKFILL, THE HEIGHT OF THE CHAMBER JOINT SHALL NOT BE LESS THAN 75 mm (3").
 - TO ENSURE THE INTEGRITY OF THE ARCH SHAPE DURING INSTALLATION, a) THE ARCH STIFFNESS CONSTANT SHALL BE GREATER THAN OR EQUAL TO 450 LBS/FT². THE ASC IS DEFINED IN SECTION 6.2.8 OF ASTM F2418. AND b) TO RESIST CHAMBER DEFORMATION DURING INSTALLATION AT ELEVATED TEMPERATURES (ABOVE 23° C / 73° F), CHAMBERS SHALL BE PRODUCED FROM REFLECTIVE GOLD OR YELLOW COLORS.
- ONLY CHAMBERS THAT ARE APPROVED BY THE SITE DESIGN ENGINEER WILL BE ALLOWED. UPON REQUEST BY THE SITE DESIGN ENGINEER OR OWNER, THE CHAMBER MANUFACTURER SHALL SUBMIT A STRUCTURAL EVALUATION FOR APPROVAL BEFORE DELIVERING CHAMBERS TO THE PROJECT SITE AS FOLLOWS:
 - THE STRUCTURAL EVALUATION SHALL BE SEALED BY A REGISTERED PROFESSIONAL ENGINEER.
 - THE STRUCTURAL EVALUATION SHALL DEMONSTRATE THAT THE SAFETY FACTORS ARE GREATER THAN OR EQUAL TO 1.95 FOR DEAD LOAD AND 1.75 FOR LIVE LOAD. THE MINIMUM REQUIRED BY ASTM F2787 AND BY SECTIONS 3 AND 12.12 OF THE AASHTO LRFD BRIDGE DESIGN SPECIFICATIONS FOR THERMOPLASTIC PIPE.
 - THE TEST DERIVED CREEP MODULUS AS SPECIFIED IN ASTM F2418 SHALL BE USED FOR PERMANENT DEAD LOAD DESIGN EXCEPT THAT IT SHALL BE THE 75-YEAR MODULUS USED FOR DESIGN.
- CHAMBERS AND END CAPS SHALL BE PRODUCED AT AN ISO 9001 CERTIFIED MANUFACTURING FACILITY.

IMPORTANT - NOTES FOR THE BIDDING AND INSTALLATION OF MC-7200 CHAMBER SYSTEM

- STORMTECH MC-7200 CHAMBERS SHALL NOT BE INSTALLED UNTIL THE MANUFACTURER'S REPRESENTATIVE HAS COMPLETED A PRE-CONSTRUCTION MEETING WITH THE INSTALLERS.
- STORMTECH MC-7200 CHAMBERS SHALL BE INSTALLED IN ACCORDANCE WITH THE "STORMTECH MC-3500/MC-7200 CONSTRUCTION GUIDE".
- CHAMBERS ARE NOT TO BE BACKFILLED WITH A DOZER OR EXCAVATOR SITUATED OVER THE CHAMBERS. STORMTECH RECOMMENDS 3 BACKFILL METHODS:
 - STONESHOOTER LOCATED OFF THE CHAMBER BED.
 - BACKFILL AS ROWS ARE BUILT USING AN EXCAVATOR ON THE FOUNDATION STONE OR SUBGRADE.
 - BACKFILL FROM OUTSIDE THE EXCAVATION USING A LONG BOOM HOE OR EXCAVATOR.
- THE FOUNDATION STONE SHALL BE LEVELED AND COMPACTED PRIOR TO PLACING CHAMBERS.
- JOINTS BETWEEN CHAMBERS SHALL BE PROPERLY SEATED PRIOR TO PLACING STONE.
- MAINTAIN MINIMUM - 230 mm (9") SPACING BETWEEN THE CHAMBER ROWS.
- INLET AND OUTLET MANIFOLDS MUST BE INSERTED A MINIMUM OF 300 mm (12") INTO CHAMBER END CAPS.
- EMBEDMENT STONE SURROUNDING CHAMBERS MUST BE A CLEAN, CRUSHED, ANGULAR STONE WELL GRADED BETWEEN ¾" AND 2" (20-50 mm).
- STONE SHALL BE BROUGHT UP EVENLY AROUND CHAMBERS SO AS NOT TO DISTORT THE CHAMBER SHAPE. STONE DEPTHS SHOULD NEVER DIFFER BY MORE THAN 300 mm (12") BETWEEN ADJACENT CHAMBER ROWS.
- STONE MUST BE PLACED ON THE TOP CENTER OF THE CHAMBER TO ANCHOR THE CHAMBERS IN PLACE AND PRESERVE ROW SPACING.
- THE CONTRACTOR MUST REPORT ANY DISCREPANCIES WITH CHAMBER FOUNDATION MATERIAL BEARING CAPACITIES TO THE SITE DESIGN ENGINEER.
- ADS RECOMMENDS THE USE OF "FLEXSTORM CATCH IT" INSERTS DURING CONSTRUCTION FOR ALL INLETS TO PROTECT THE SUBSURFACE STORMWATER MANAGEMENT SYSTEM FROM CONSTRUCTION SITE RUNOFF.

NOTES FOR CONSTRUCTION EQUIPMENT

- STORMTECH MC-7200 CHAMBERS SHALL BE INSTALLED IN ACCORDANCE WITH THE "STORMTECH MC-7200 CONSTRUCTION GUIDE".
 - THE USE OF EQUIPMENT OVER MC-7200 CHAMBERS IS LIMITED:
 - NO EQUIPMENT IS ALLOWED ON BARE CHAMBERS
 - NO RUBBER Tired LOADER, DUMP TRUCK, OR EXCAVATORS ARE ALLOWED UNTIL PROPER FILL DEPTHS ARE REACHED IN ACCORDANCE WITH THE "STORMTECH MC-7200 CONSTRUCTION GUIDE".
 - WEIGHT LIMITS FOR CONSTRUCTION EQUIPMENT CAN BE FOUND IN THE "STORMTECH MC-7200 CONSTRUCTION GUIDE".
 - FULL 900 mm (36") OF STABILIZED COVER MATERIALS OVER THE CHAMBERS IS REQUIRED FOR DUMP TRUCK TRAVEL OR DUMPING.
- USE OF A DOZER TO PUSH EMBEDMENT STONE BETWEEN THE ROWS OF CHAMBERS MAY CAUSE DAMAGE TO CHAMBERS AND IS NOT AN ACCEPTABLE BACKFILL METHOD. ANY CHAMBERS DAMAGED BY USING THE "DUMP AND PUSH" METHOD ARE NOT COVERED UNDER THE STORMTECH STANDARD WARRANTY.

CONTACT STORMTECH AT 1-888-892-2694 WITH ANY QUESTIONS ON INSTALLATION REQUIREMENTS OR WEIGHT LIMITS FOR CONSTRUCTION EQUIPMENT.

IMPORTANT - THIS PROJECT REQUIRES COMPACTION OF EMBEDMENT STONE AND REQUIREMENTS FOR STONE HARDNESS AND SHAPE WHICH ARE NOT SPECIFIED IN OTHER STORMTECH DOCUMENTS. CONTRACTORS MUST FOLLOW THE SPECIAL PROVISIONS IN THIS PLAN SET.

PROPOSED LAYOUT

15	STORMTECH MC-7200 CHAMBERS
10	STORMTECH MC-7200 END CAPS
305	STONE ABOVE (mm)
229	STONE BELOW (mm)
40	% STONE VOID
159.1	INSTALLED SYSTEM VOLUME (m ³) ABOVE ELEVATION 76.00 (PERIMETER STONE INCLUDED)
153.6	SYSTEM AREA (m ²)
50.0	SYSTEM PERIMETER (m)

PROPOSED ELEVATIONS

80.350	MAXIMUM GRADE PER ENGINEERS PLAN:
78.243	MINIMUM ALLOWABLE GRADE (UNPAVED WITH TRAFFIC):
78.091	MINIMUM ALLOWABLE GRADE (UNPAVED NO TRAFFIC):
78.091	MINIMUM ALLOWABLE GRADE (BASE OF FLEXIBLE PAVEMENT):
78.091	MINIMUM ALLOWABLE GRADE (TOP OF RIGID PAVEMENT):
77.786	TOP OF STONE:
77.481	TOP OF MC-7200 CHAMBER:
76.854	300 mm TOP MANIFOLD INVERT:
76.014	600 mm ISOLATOR ROW PLUS INVERT:
75.957	BOTTOM OF MC-7200 CHAMBER:
75.728	BOTTOM OF STONE:

NOTES

- MANIFOLD SIZE TO BE DETERMINED BY SITE DESIGN ENGINEER. SEE TECHNICAL NOTE 6.32 FOR MANIFOLD SIZING GUIDANCE.
- DUE TO THE ADAPTATION OF THIS CHAMBER SYSTEM TO SPECIFIC SITE AND DESIGN CONSTRAINTS, IT MAY BE NECESSARY TO CUT AND COUPLE ADDITIONAL PIPE TO STANDARD MANIFOLD COMPONENTS IN THE FIELD.
- THE SITE DESIGN ENGINEER MUST REVIEW ELEVATIONS AND IF NECESSARY ADJUST GRADING TO ENSURE THE CHAMBER COVER REQUIREMENTS ARE MET.
- THIS CHAMBER SYSTEM WAS DESIGNED WITHOUT SITE-SPECIFIC INFORMATION ON SOIL CONDITIONS OR BEARING CAPACITY. THE SITE DESIGN ENGINEER IS RESPONSIBLE FOR DETERMINING THE SUITABILITY OF THE SOIL AND PROVIDING THE BEARING CAPACITY OF THE INSITU SOILS. THE BASE STONE DEPTH MAY BE INCREASED OR DECREASED ONCE THIS INFORMATION IS PROVIDED.

TIER 1 DEEP COVER SPECIAL PROVISIONS

1. INSTALLATION REQUIREMENTS SHALL BE AS SPECIFIED IN THE STORMTECH DESIGN MANUALS AND CONSTRUCTION GUIDES EXCEPT AS MODIFIED IN THESE SPECIAL PROVISIONS.
2. ATTENTION IS CALLED TO "TABLE 1 - ACCEPTABLE FILL MATERIALS" IN THE STORMTECH CONSTRUCTION GUIDE AND ALL OTHER APPEARANCES OF THE "ACCEPTABLE FILL MATERIALS TABLE. FOR AREAS OF THE SYSTEM WITH COVER ABOVE 7 FEET (2.1 m) FOR THE MC-4500/MC-7200 AND ABOVE 8 FEET (2.4 m) FOR THE MC-3500, EMBEDMENT STONE SHALL BE COMPACTED WITH 1-3 PASSES OF A WALK BEHIND VIBRATORY PLATE COMPACTOR OR JUMPING JACK IN 12-18" (300-450 mm) LIFTS.
3. STONE SHALL BE CLEAN, CRUSHED, AND ANGULAR AND SHALL CONFORM TO THE SPECIFICATIONS DESIGNATED IN THE ACCEPTABLE FILL MATERIALS TABLE.
4. STONE SHALL BE HARD AND DURABLE. IT IS THE ENGINEER'S OR CONTRACTOR'S RESPONSIBILITY TO SELECT HARD AND DURABLE STONE. STORMTECH CONSIDERS AN LA ABRASION VALUE OF LESS THAN OR EQUAL TO 30 TO BE HARD STONE.
5. FOUNDATION STONE SHALL BE MECHANICALLY COMPACTED WITH A VIBRATORY ROLLER OR VIBRATORY PLATE IN 6" (152 mm) LIFTS.
6. EMBEDMENT STONE MUST BE DUMPED IN PLACE BY A STONE SHOOTER OR CONVEYOR OR EXCAVATOR.
7. INSPECTION DURING THE INSTALLATION BY THE ENGINEER, OWNER OR OTHER REPRESENTATIVE IS RECOMMENDED. THE INSPECTION SHALL INCLUDE OBSERVATIONS OF THE CHAMBER SYMMETRY DURING BACKFILLING TO ENSURE THE CONTRACTOR'S METHODS ARE NOT CAUSING UNACCEPTABLE DISTORTION OF THE CHAMBERS.
8. AN ADS FIELD TECHNICIAN WILL CONDUCT A PRE-CONSTRUCTION MEETING TO TRAIN REPRESENTATIVES INSTALLING THE CHAMBERS AND THOSE WHO MAY BE PERFORMING INSTALLATION INSPECTIONS.

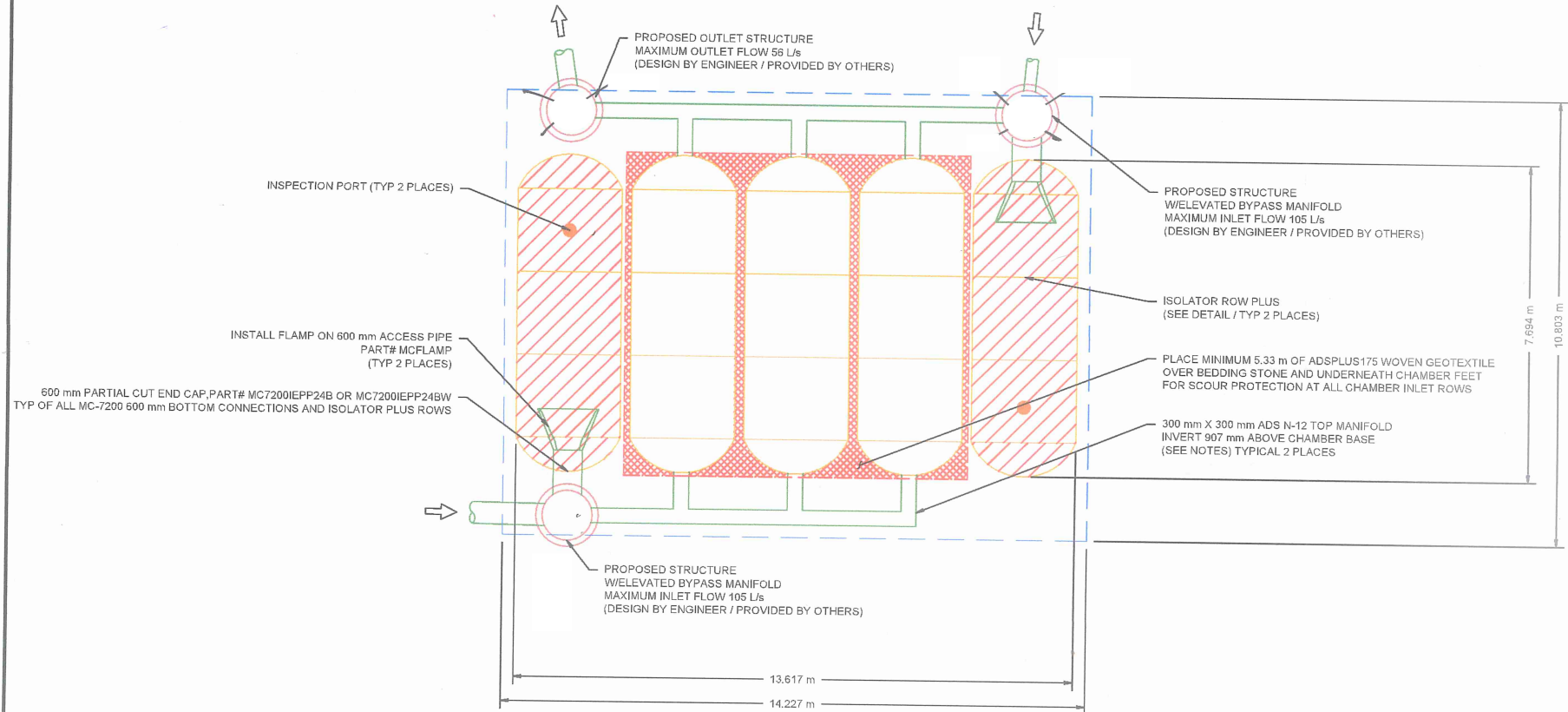

U OTTAWA
ADVANCED MEDICAL RESEARCH CTR
OTTAWA, ON.

DATE: 10/26/23 DRAWN: RCT
PROJECT #: S381206 CHECKED: RCT

REVISED PER LATEST PLAN/VOLUME	DATE	BY	DESCRIPTION
20/24	RCT	RCT	REVISOR
13/14/23	RCT	RCT	BASE VOLUME WITH STD STONE
13/12/23	RCT	RCT	REDUCED VOLUMES SHADDED STONE
10/30/23	RCT	RCT	REDUCED VOLUMES PER NEW PLAN
	DATE	DRAWN	CHECKED

StormTech®
Chamber System
888-892-2694 | WWW.STORMTECH.COM

4640 TRUEMAN BLVD
HILLIARD, OH 43026

SCALE = 1 : 100

ACCEPTABLE FILL MATERIALS: STORMTECH MC-7200 CHAMBER SYSTEMS

MATERIAL LOCATION	DESCRIPTION	AASHTO MATERIAL CLASSIFICATIONS	COMPACTION / DENSITY REQUIREMENT
D	FINAL FILL: FILL MATERIAL FOR LAYER 'D' STARTS FROM THE TOP OF THE 'C' LAYER TO THE BOTTOM OF FLEXIBLE PAVEMENT OR UNPAVED FINISHED GRADE ABOVE. NOTE THAT PAVEMENT SUBBASE MAY BE PART OF THE 'D' LAYER	N/A	PREPARE PER SITE DESIGN ENGINEER'S PLANS. PAVED INSTALLATIONS MAY HAVE STRINGENT MATERIAL AND PREPARATION REQUIREMENTS.
C	INITIAL FILL: FILL MATERIAL FOR LAYER 'C' STARTS FROM THE TOP OF THE EMBEDMENT STONE ('B' LAYER) TO 24" (600 mm) ABOVE THE TOP OF THE CHAMBER. NOTE THAT PAVEMENT SUBBASE MAY BE A PART OF THE 'C' LAYER.	AASHTO M145 ¹ A-1, A-2.4, A-3 OR AASHTO M43 ¹ 3, 357, 4, 467, 5, 56, 57, 6, 67, 68, 7, 78, 8, 89, 9, 10	BEGIN COMPACTIONS AFTER 24" (600 mm) OF MATERIAL OVER THE CHAMBERS IS REACHED. COMPACT ADDITIONAL LAYERS IN 12" (300 mm) MAX LIFTS TO A MIN. 95% PROCTOR DENSITY FOR WELL GRADED MATERIAL AND 95% RELATIVE DENSITY FOR PROCESSED AGGREGATE MATERIALS.
B	EMBEDMENT STONE: FILL SURROUNDING THE CHAMBERS FROM THE FOUNDATION STONE ('A' LAYER) TO THE 'C' LAYER ABOVE.	AASHTO M43 ¹ 3, 4	COMPACTION REQUIRED. SEE SPECIAL REQUIREMENTS ON LAYOUT PAGE.
A	FOUNDATION STONE: FILL BELOW CHAMBERS FROM THE SUBGRADE UP TO THE FOOT (BOTTOM) OF THE CHAMBER.	AASHTO M43 ¹ 3, 4	PLATE COMPACT OR ROLL TO ACHIEVE A FLAT SURFACE. ^{2,3}

PLEASE NOTE:

- THE LISTED AASHTO DESIGNATIONS ARE FOR GRADATIONS ONLY. THE STONE MUST ALSO BE CLEAN, CRUSHED, ANGULAR. FOR EXAMPLE, A SPECIFICATION FOR #4 STONE WOULD STATE: "CLEAN, CRUSHED, ANGULAR NO. 4 (AASHTO M43) STONE".
- STORMTECH COMPACTION REQUIREMENTS ARE MET FOR 'A' LOCATION MATERIALS WHEN PLACED AND COMPACTED IN 9" (230 mm) (MAX) LIFTS USING TWO FULL COVERAGES WITH A VIBRATORY COMPACTOR.
- WHERE INFILTRATION SURFACES MAY BE COMPROMISED BY COMPACTION, FOR STANDARD DESIGN LOAD CONDITIONS, A FLAT SURFACE MAY BE ACHIEVED BY RAKING OR DRAGGING WITHOUT COMPACTION EQUIPMENT. FOR SPECIAL LOAD DESIGNS, CONTACT STORMTECH FOR COMPACTION REQUIREMENTS.
- ONCE LAYER 'C' IS PLACED, ANY SOIL/MATERIAL CAN BE PLACED IN LAYER 'D' UP TO THE FINISHED GRADE. MOST PAVEMENT SUBBASE SOILS CAN BE USED TO REPLACE THE MATERIAL REQUIREMENTS OF LAYER 'C' OR 'D' AT THE SITE DESIGN ENGINEER'S DISCRETION.

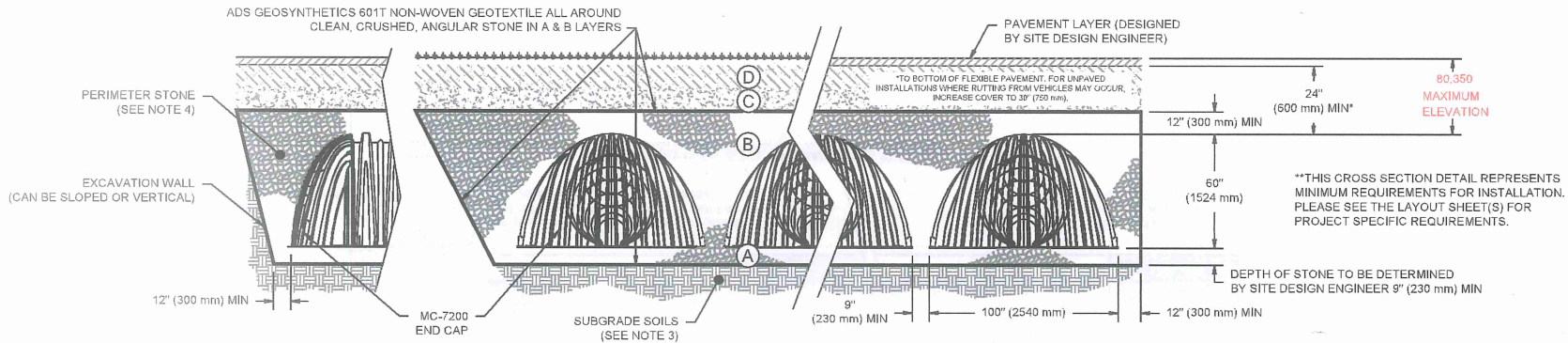

NOTES:

- CHAMBERS SHALL MEET THE REQUIREMENTS OF ASTM F2418, "STANDARD SPECIFICATION FOR POLYPROPYLENE (PP) CORRUGATED WALL STORMWATER COLLECTION CHAMBERS" CHAMBER CLASSIFICATION 60x101
- MC-7200 CHAMBERS SHALL BE DESIGNED IN ACCORDANCE WITH ASTM F2787 "STANDARD PRACTICE FOR STRUCTURAL DESIGN OF THERMOPLASTIC CORRUGATED WALL STORMWATER COLLECTION CHAMBERS".
- THE SITE DESIGN ENGINEER IS RESPONSIBLE FOR ASSESSING THE BEARING RESISTANCE (ALLOWABLE BEARING CAPACITY) OF THE SUBGRADE SOILS AND THE DEPTH OF FOUNDATION STONE WITH CONSIDERATION FOR THE RANGE OF EXPECTED SOIL MOISTURE CONDITIONS.
- PERIMETER STONE MUST BE EXTENDED HORIZONTALLY TO THE EXCAVATION WALL FOR BOTH VERTICAL AND SLOPED EXCAVATION WALLS.
- REQUIREMENTS FOR HANDLING AND INSTALLATION
 - TO MAINTAIN THE WIDTH OF CHAMBERS DURING SHIPPING AND HANDLING, CHAMBERS SHALL HAVE INTEGRAL, INTERLOCKING STACKING LUGS.
 - TO ENSURE A SECURE JOINT DURING INSTALLATION AND BACKFILL, THE HEIGHT OF THE CHAMBER JOINT SHALL NOT BE LESS THAN 3".
 - TO ENSURE THE INTEGRITY OF THE ARCH SHAPE DURING INSTALLATION, a) THE ARCH STIFFNESS CONSTANT AS DEFINED IN SECTION 6.2.8 OF ASTM F2418 SHALL BE GREATER THAN OR EQUAL TO 500 LBS/FT²%. AND b) TO RESIST CHAMBER DEFORMATION DURING INSTALLATION AT ELEVATED TEMPERATURES (ABOVE 73° F / 23° C), CHAMBERS SHALL BE PRODUCED FROM REFLECTIVE GOLD OR YELLOW COLORS.

U OTTAWA
ADVANCED MEDICAL RESEARCH CTR
OTTAWA, ON.

DATE: 10/26/23
DRAWN: RCT
CHECKED: RCT

DATE: 02/24/23
13/24/23
19/24/23
19/24/23

DESCRIPTION

DATE

DESCRIPTION

DATE

DESCRIPTION

DATE

DESCRIPTION

DATE

DESCRIPTION

DATE

DESCRIPTION

DATE

DESCRIPTION

DATE

DESCRIPTION

DATE

DESCRIPTION

DATE

DESCRIPTION

DATE

DESCRIPTION

DATE

DESCRIPTION

DATE

DESCRIPTION

DATE

DESCRIPTION

DATE

DESCRIPTION

DATE

DESCRIPTION

DATE

DESCRIPTION

DATE

DESCRIPTION

DATE

DESCRIPTION

DATE

DESCRIPTION

DATE

DESCRIPTION

DATE

DESCRIPTION

DATE

DESCRIPTION

DATE

DESCRIPTION

DATE

DESCRIPTION

DATE

DESCRIPTION

DATE

DESCRIPTION

DATE

DESCRIPTION

DATE

DESCRIPTION

DATE

DESCRIPTION

DATE

DESCRIPTION

DATE

DESCRIPTION

DATE

DESCRIPTION

DATE

DESCRIPTION

DATE

DESCRIPTION

DATE

DESCRIPTION

DATE

DESCRIPTION

DATE

DESCRIPTION

DATE

DESCRIPTION

DATE

DESCRIPTION

DATE

DESCRIPTION

DATE

DESCRIPTION

DATE

DESCRIPTION

DATE

DESCRIPTION

DATE

DESCRIPTION

DATE

DESCRIPTION

DATE

DESCRIPTION

DATE

DESCRIPTION

DATE

DESCRIPTION

DATE

DESCRIPTION

DATE

DESCRIPTION

DATE

DESCRIPTION

DATE

DESCRIPTION

DATE

DESCRIPTION

DATE

DESCRIPTION

DATE

DESCRIPTION

DATE

DESCRIPTION

DATE

DESCRIPTION

DATE

DESCRIPTION

DATE

DESCRIPTION

DATE

DESCRIPTION

DATE

DESCRIPTION

DATE

DESCRIPTION

DATE

DESCRIPTION

DATE

DESCRIPTION

DATE

DESCRIPTION

DATE

DESCRIPTION

DATE

DESCRIPTION

DATE

DESCRIPTION

DATE

DESCRIPTION

DATE

DESCRIPTION

DATE

DESCRIPTION

DATE

DESCRIPTION

DATE

DESCRIPTION

DATE

DESCRIPTION

DATE

DESCRIPTION

DATE

DESCRIPTION

DATE

DESCRIPTION

DATE

DESCRIPTION

DATE

DESCRIPTION

DATE

DESCRIPTION

DATE

DESCRIPTION

DATE

DESCRIPTION

DATE

DESCRIPTION

DATE

DESCRIPTION

DATE

DESCRIPTION

DATE

DESCRIPTION

DATE

DESCRIPTION

DATE

DESCRIPTION

DATE

DESCRIPTION

DATE

DESCRIPTION

DATE

DESCRIPTION

DATE

DESCRIPTION

DATE

DESCRIPTION

DATE

DESCRIPTION

DATE

DESCRIPTION

DATE

DESCRIPTION

DATE

DESCRIPTION

DATE

DESCRIPTION

DATE

DESCRIPTION

DATE

DESCRIPTION

DATE

DESCRIPTION

DATE

DESCRIPTION

DATE

DESCRIPTION

DATE

DESCRIPTION

DATE

DESCRIPTION

DATE

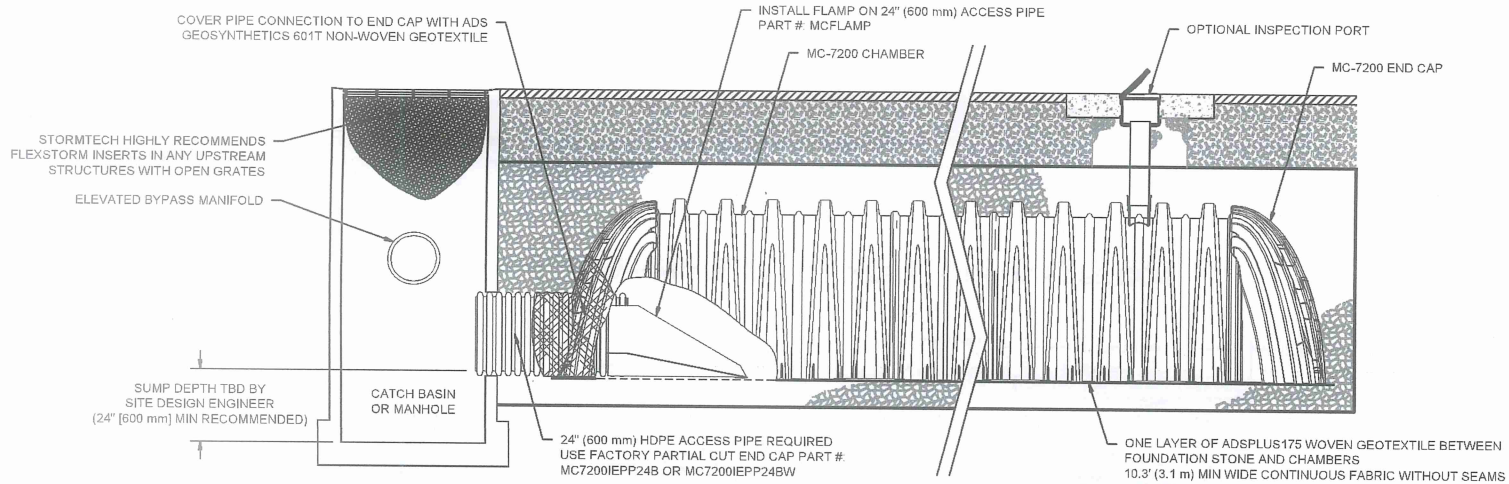

MC-7200 ISOLATOR ROW PLUS DETAIL
NTS

INSPECTION & MAINTENANCE

- STEP 1) INSPECT ISOLATOR ROW PLUS FOR SEDIMENT
- A. INSPECTION PORTS (IF PRESENT)
 - A.1. REMOVE/OPEN LID ON NYLOPLAST INLINE DRAIN
 - A.2. REMOVE AND CLEAN FLEXSTORM FILTER IF INSTALLED
 - A.3. USING A FLASHLIGHT AND STADIA ROD, MEASURE DEPTH OF SEDIMENT AND RECORD ON MAINTENANCE LOG
 - A.4. LOWER A CAMERA INTO ISOLATOR ROW PLUS FOR VISUAL INSPECTION OF SEDIMENT LEVELS (OPTIONAL)
 - A.5. IF SEDIMENT IS AT, OR ABOVE, 3" (80 mm) PROCEED TO STEP 2. IF NOT, PROCEED TO STEP 3.
 - B. ALL ISOLATOR PLUS ROWS
 - B.1. REMOVE COVER FROM STRUCTURE AT UPSTREAM END OF ISOLATOR ROW PLUS
 - B.2. USING A FLASHLIGHT, INSPECT DOWN THE ISOLATOR ROW PLUS THROUGH OUTLET PIPE
 - i) MIRRORS ON POLES OR CAMERAS MAY BE USED TO AVOID A CONFINED SPACE ENTRY
 - ii) FOLLOW OSHA REGULATIONS FOR CONFINED SPACE ENTRY IF ENTERING MANHOLE
 - iii) IF SEDIMENT IS AT, OR ABOVE, 3" (80 mm) PROCEED TO STEP 2. IF NOT, PROCEED TO STEP 3.
- STEP 2) CLEAN OUT ISOLATOR ROW PLUS USING THE JETVAC PROCESS
- A. A FIXED CULVERT CLEANING NOZZLE WITH REAR FACING SPREAD OF 45° (1.1 m) OR MORE IS PREFERRED
 - B. APPLY MULTIPLE PASSES OF JETVAC UNTIL BACKFLUSH WATER IS CLEAN
 - C. VACUUM STRUCTURE SUMP AS REQUIRED
- STEP 3) REPLACE ALL COVERS, GRATES, FILTERS, AND LIDS; RECORD OBSERVATIONS AND ACTIONS.
- STEP 4) INSPECT AND CLEAN BASINS AND MANHOLES UPSTREAM OF THE STORMTECH SYSTEM.

NOTES

1. INSPECT EVERY 6 MONTHS DURING THE FIRST YEAR OF OPERATION. ADJUST THE INSPECTION INTERVAL BASED ON PREVIOUS OBSERVATIONS OF SEDIMENT ACCUMULATION AND HIGH WATER ELEVATIONS.
2. CONDUCT JETTING AND VACTORING ANNUALLY OR WHEN INSPECTION SHOWS THAT MAINTENANCE IS NECESSARY.

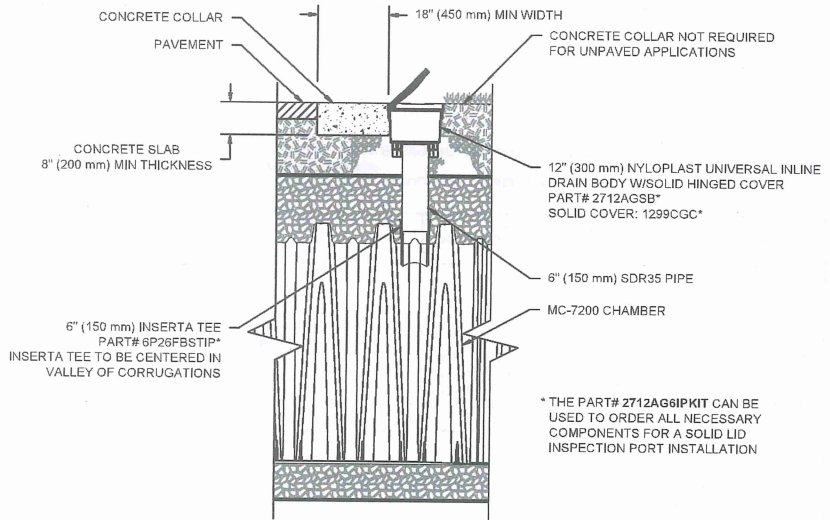

MC-7200 6" (150 mm) INSPECTION PORT DETAIL
NTS

U OTTAWA
ADVANCED MEDICAL RESEARCH CTR
OTTAWA, ON

DATE:	10/29/23	DRAWN:	RCT	CHECKED:	RCT
PROJECT #:	S381206				

DATE	BY	CHKD	DESCRIPTION
2/2/24	RCT	RCT	REVISED PER LATEST PLAN VOLUME
12/14/23	RCT	RCT	SAME VOLUME WITH STD STONE
12/12/23	RCT	RCT	REDUCED VOLUMES ENHANCED STONE
10/30/23	RCT	RCT	REDUCED VOLUMES PER NEW PLAN

StormTech®
Chamber System
888-992-2984 | WWW.STORMTECH.COM

4840 TRUEMAN BLVD
HILLIARD, OH 43026

THIS DRAWING HAS BEEN PREPARED BASED ON INFORMATION PROVIDED TO ADS UNDER THE DIRECTION OF THE SITE DESIGN ENGINEER OR OTHER PROJECT REPRESENTATIVE. THE SITE DESIGN ENGINEER SHALL REVIEW THIS DRAWING PRIOR TO CONSTRUCTION. IT IS THE ULTIMATE RESPONSIBILITY OF THE SITE DESIGN ENGINEER TO ENSURE THAT THE PRODUCT IS DESIGNED AND ALL ASSOCIATED DETAILS MEET ALL APPLICABLE LAWS, REGULATIONS AND PROJECT REQUIREMENTS.

MC-7200 TECHNICAL SPECIFICATION

NTS

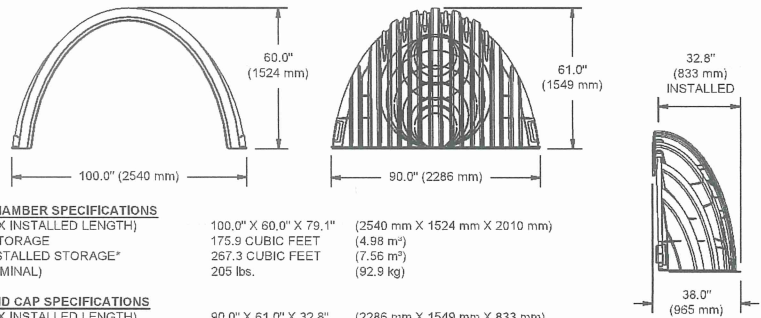
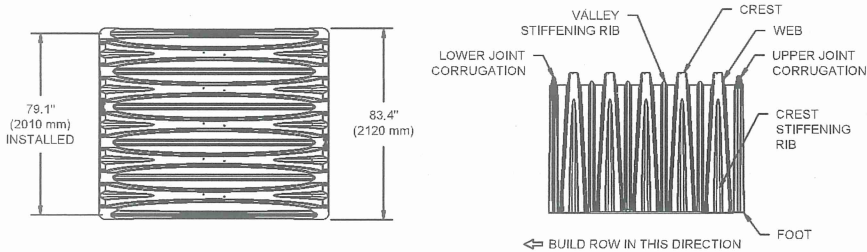

NOMINAL CHAMBER SPECIFICATIONS

SIZE (W X H X INSTALLED LENGTH)	100.0\" X 60.0\" X 79.1\"	(2540 mm X 1524 mm X 2010 mm)
CHAMBER STORAGE	175.9 CUBIC FEET	(4.98 m ³)
MINIMUM INSTALLED STORAGE*	267.3 CUBIC FEET	(7.56 m ³)
WEIGHT (NOMINAL)	205 lbs.	(92.9 kg)

NOMINAL END CAP SPECIFICATIONS

SIZE (W X H X INSTALLED LENGTH)	90.0\" X 61.0\" X 32.8\"	(2286 mm X 1549 mm X 833 mm)
END CAP STORAGE	39.5 CUBIC FEET	(1.12 m ³)
MINIMUM INSTALLED STORAGE*	115.3 CUBIC FEET	(3.26 m ³)
WEIGHT (NOMINAL)	90 lbs.	(40.8 kg)

*ASSUMES 12\" (305 mm) STONE ABOVE, 8\" (229 mm) STONE FOUNDATION AND BETWEEN CHAMBERS, 12\" (305 mm) STONE PERIMETER IN FRONT OF END CAPS AND 40% STONE POROSITY.

PARTIAL CUT HOLES AT BOTTOM OF END CAP FOR PART NUMBERS ENDING WITH 'B'
PARTIAL CUT HOLES AT TOP OF END CAP FOR PART NUMBERS ENDING WITH 'T'
END CAPS WITH A PREFABRICATED WELDED STUB END WITH 'W'

PART #	STUB	B	C
MC7200IEPP06T	6\" (150 mm)	42.54\" (1081 mm)	—
MC7200IEPP06B	—	—	0.86\" (22 mm)
MC7200IEPP08T	8\" (200 mm)	40.50\" (1029 mm)	—
MC7200IEPP08B	—	—	1.01\" (26 mm)
MC7200IEPP10T	10\" (250 mm)	38.37\" (975 mm)	—
MC7200IEPP10B	—	—	1.33\" (34 mm)
MC7200IEPP12T	12\" (300 mm)	35.69\" (907 mm)	—
MC7200IEPP12B	—	—	1.55\" (39 mm)
MC7200IEPP15T	15\" (375 mm)	32.72\" (831 mm)	—
MC7200IEPP15B	—	—	1.70\" (43 mm)
MC7200IEPP18T	18\" (450 mm)	29.36\" (746 mm)	—
MC7200IEPP18TW	—	—	1.97\" (50 mm)
MC7200IEPP18B	—	—	—
MC7200IEPP24T	24\" (600 mm)	23.05\" (585 mm)	—
MC7200IEPP24TW	—	—	—
MC7200IEPP24B	—	—	2.26\" (57 mm)
MC7200IEPP24BW	—	—	—
MC7200IEPP30BW	30\" (750 mm)	—	2.95\" (75 mm)
MC7200IEPP36BW	36\" (900 mm)	—	3.25\" (83 mm)
MC7200IEPP42BW	42\" (1050 mm)	—	3.55\" (90 mm)

NOTE: ALL DIMENSIONS ARE NOMINAL

MC-SERIES END CAP INSERTION DETAIL

NTS

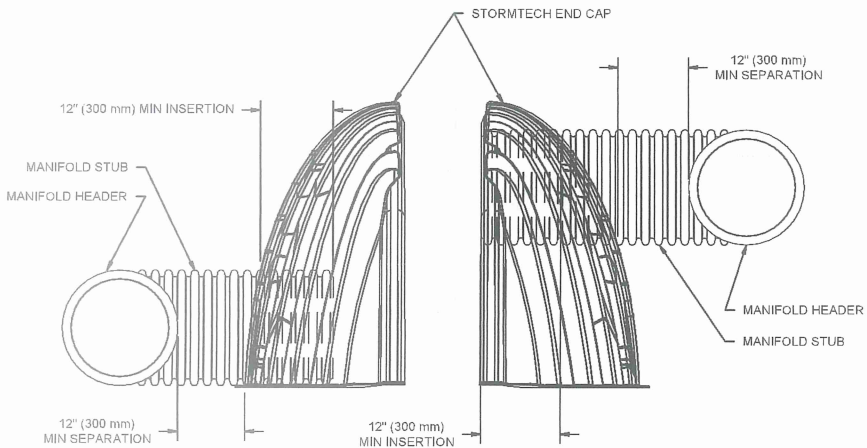

NOTE: MANIFOLD STUB MUST BE LAID HORIZONTAL FOR A PROPER FIT IN END CAP OPENING.

U OTTAWA
ADVANCED MEDICAL RESEARCH CTR
OTTAWA, ON.

DATE:	10/26/23	DRAWN:	RCT
PROJECT #:	S381206	CHECKED:	RCT
REVISION	DESCRIPTION	DATE	BY
1	REVISED PER LATEST PLAN VOLUME		
2	REVISED PER LATEST PLAN VOLUME		
3	REVISED PER LATEST PLAN VOLUME		
4	REVISED PER LATEST PLAN VOLUME		
5	REVISED PER LATEST PLAN VOLUME		
6	REVISED PER LATEST PLAN VOLUME		
7	REVISED PER LATEST PLAN VOLUME		
8	REVISED PER LATEST PLAN VOLUME		
9	REVISED PER LATEST PLAN VOLUME		
10	REVISED PER LATEST PLAN VOLUME		
11	REVISED PER LATEST PLAN VOLUME		
12	REVISED PER LATEST PLAN VOLUME		
13	REVISED PER LATEST PLAN VOLUME		
14	REVISED PER LATEST PLAN VOLUME		
15	REVISED PER LATEST PLAN VOLUME		
16	REVISED PER LATEST PLAN VOLUME		
17	REVISED PER LATEST PLAN VOLUME		
18	REVISED PER LATEST PLAN VOLUME		
19	REVISED PER LATEST PLAN VOLUME		
20	REVISED PER LATEST PLAN VOLUME		
21	REVISED PER LATEST PLAN VOLUME		
22	REVISED PER LATEST PLAN VOLUME		
23	REVISED PER LATEST PLAN VOLUME		
24	REVISED PER LATEST PLAN VOLUME		
25	REVISED PER LATEST PLAN VOLUME		
26	REVISED PER LATEST PLAN VOLUME		
27	REVISED PER LATEST PLAN VOLUME		
28	REVISED PER LATEST PLAN VOLUME		
29	REVISED PER LATEST PLAN VOLUME		
30	REVISED PER LATEST PLAN VOLUME		
31	REVISED PER LATEST PLAN VOLUME		
32	REVISED PER LATEST PLAN VOLUME		
33	REVISED PER LATEST PLAN VOLUME		
34	REVISED PER LATEST PLAN VOLUME		
35	REVISED PER LATEST PLAN VOLUME		
36	REVISED PER LATEST PLAN VOLUME		
37	REVISED PER LATEST PLAN VOLUME		
38	REVISED PER LATEST PLAN VOLUME		
39	REVISED PER LATEST PLAN VOLUME		
40	REVISED PER LATEST PLAN VOLUME		
41	REVISED PER LATEST PLAN VOLUME		
42	REVISED PER LATEST PLAN VOLUME		
43	REVISED PER LATEST PLAN VOLUME		
44	REVISED PER LATEST PLAN VOLUME		
45	REVISED PER LATEST PLAN VOLUME		
46	REVISED PER LATEST PLAN VOLUME		
47	REVISED PER LATEST PLAN VOLUME		
48	REVISED PER LATEST PLAN VOLUME		
49	REVISED PER LATEST PLAN VOLUME		
50	REVISED PER LATEST PLAN VOLUME		

StormTech®
Chamber System
888-892-2694 | WWW.STORMTECH.COM

4640 TRUEMAN BLVD
HILLIARD, OH 43026
ADS



Adjustable Accutrol Weir

Tag: _____

Adjustable Flow Control for Roof Drains

ADJUSTABLE ACCUTROL (for Large Sump Roof Drains only)

For more flexibility in controlling flow with heads deeper than 2", Watts Drainage offers the Adjustable Accutrol. The Adjustable Accutrol Weir is designed with a single parabolic opening that can be covered to restrict flow above 2" of head to less than 5 gpm per inch, up to 6" of head. To adjust the flow rate for depths over 2" of head, set the slot in the adjustable upper cone according to the flow rate required. Refer to Table 1 below.
 Note: Flow rates are directly proportional to the amount of weir opening that is exposed.

EXAMPLE:

For example, if the adjustable upper cone is set to cover 1/2 of the weir opening, flow rates above 2" of head will be restricted to 2-1/2 gpm per inch of head.

Therefore, at 3" of head, the flow rate through the Accutrol Weir that has 1/2 the slot exposed will be:
 [5 gpm (per inch of head) x 2 inches of head] + 2-1/2 gpm (for the third inch of head) = 12-1/2 gpm.

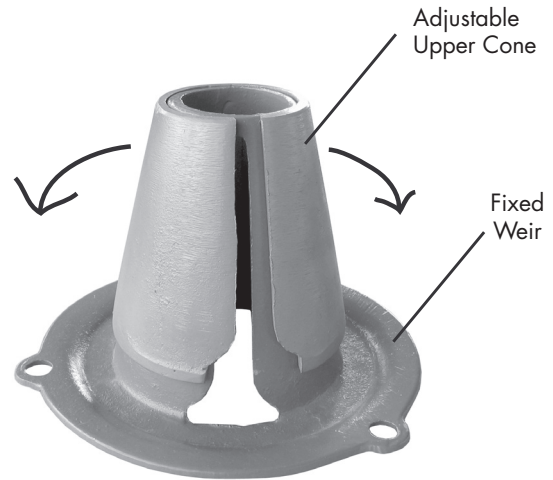
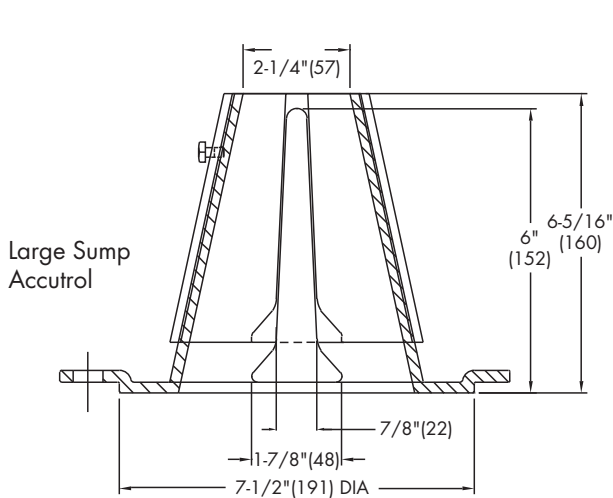

1/2 Weir Opening Exposed Shown Above

TABLE 1. Adjustable Accutrol Flow Rate Settings

Weir Opening Exposed	1"	2"	3"	4"	5"	6"
	Flow Rate (gallons per minute)					
Fully Exposed	5	10	15	20	25	30
3/4	5	10	13.75	17.5	21.25	25
1/2	5	10	12.5	15	17.5	20
1/4	5	10	11.25	12.5	13.75	15
Closed	5	5	5	5	5	5

Job Name _____
 Job Location _____
 Engineer _____

Contractor _____
 Contractor's P.O. No. _____
 Representative _____

Watts product specifications in U.S. customary units and metric are approximate and are provided for reference only. For precise measurements, please contact Watts Technical Service. Watts reserves the right to change or modify product design, construction, specifications, or materials without prior notice and without incurring any obligation to make such changes and modifications on Watts products previously or subsequently sold.

USA: Tel: (800) 338-2581 • Fax: (828) 248-3929 • Watts.com
 Canada: Tel: (905) 332-4090 • Fax: (905) 332-7068 • Watts.ca
 Latin America: Tel: (52) 81-1001-8600 • Fax: (52) 81-8000-7091 • Watts.com



A Watts Water Technologies Company

APPENDIX 7-C
ICD CURVES

IPEX ICD Curves

ADVANTAGES

Alleviates Basement Flooding

By restricting flow of stormwater into the sewer system, and temporarily ponding water in catchbasins, parking lots and roadways, sewer capacity is increased. Pipe upstream that would have otherwise been surcharged has greater capacity, reducing basement flooding. All this for a fraction of the cost of installing larger pipes.

Sump Scouring Action

The rectangular slot at the bottom of the orifice works effectively in two ways. First, during dry periods it draws the water level below the main orifice area, keeping it clear of floating debris. Second, it generates strong vortex action in the

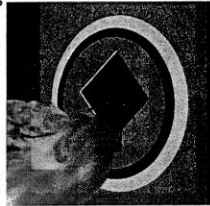

approach flow during heavy rainfalls, vigorously scouring sediment from the sump of the catchbasin.

Fits Any Type of Pipe

IPEX ICDs can be fabricated to fit any type of pipe – PVC, concrete, clay, or a host of other products. Simply contact your local representative with details and leave the rest to IPEX.

DESIGN NOTES

Calibration curves for the five standard sizes at various heads are shown. The values shown are empirical, developed by the University of Ottawa's Department of Civil Engineering.

*Head is measured from the centre line of the diamond to the water elevation or flood level.

SHORT FORM SPECIFICATIONS

IPEX Inlet Control Devices (ICDs) are manufactured from Polyvinyl Chloride (PVC) to be supplied according to the type (i.e. A, B, C, D, or F) as shown in the engineer's drawings.

IPEX Plug ICDs are to be machined to provide a friction fit into the outlet pipe.

Framed ICDs are to be bolted in position over appropriate outlet pipe in the catchbasin/maintenance hole.

Calibration Curves for Standard ICDs

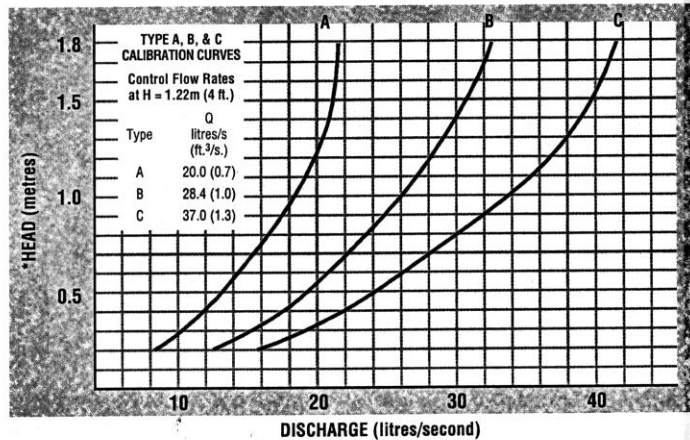

Note: 200mm (8") ICD Plugs available in Type A & B only.

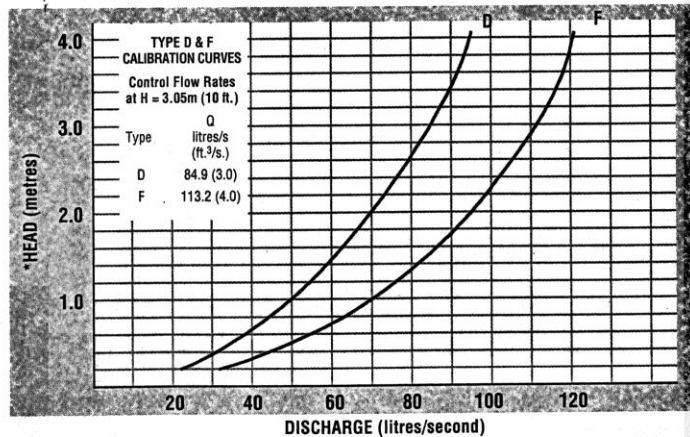

Note: Type D and F can fit pipes ≥ 250mm (10").

John Meunier - Hydrovex VHV ICD Curves

Hydrovex® VHV
Vertical Vortex Flow Regulator

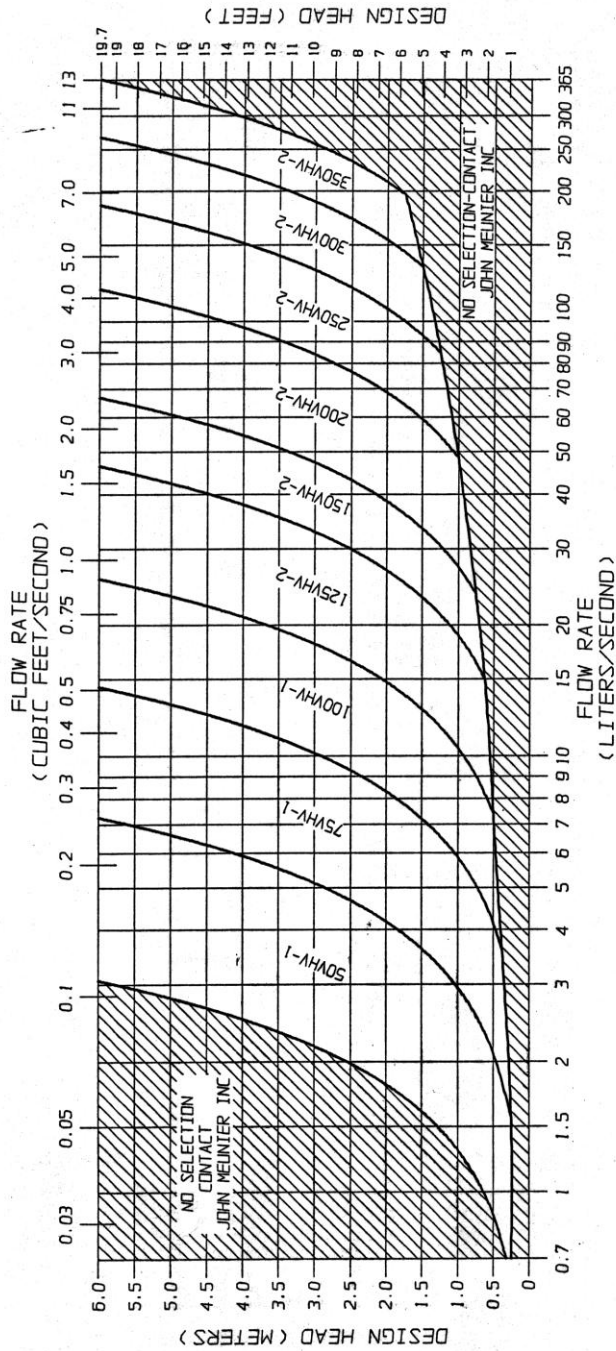

FIGURE 2 - VHV



JOHN MEUNIER

John Meunier - Hydrovex SVHV ICD Curves

Hydrovex® SVHV
Vertical Vortex Flow Regulator

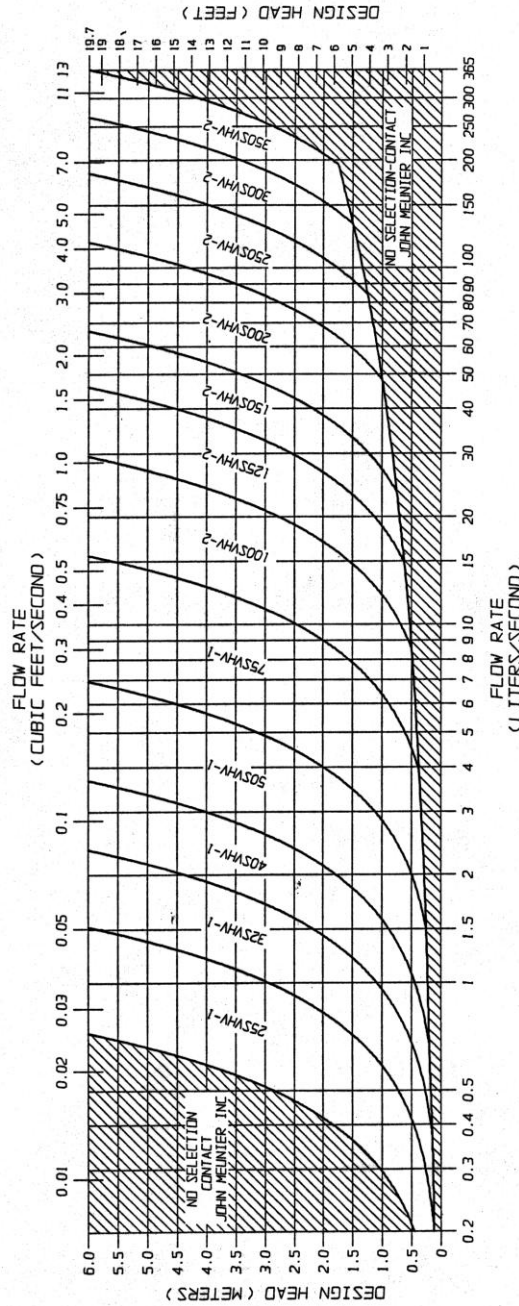

FIGURE 2 - SVHV



JOHN MEUNIER

Verification Statement



StormTech Isolator® Row PLUS Registration number: (V-2020-10-01) Date of issue: (2020-October-27)

Technology type	Stormwater Filtration Device	
Application	Stormwater filtration technology to remove sediments, nutrients, heavy metals, and organic contaminants from stormwater runoff	
Company	StormTech, LLC.	
Address	520 Cromwell Avenue, Rocky Hill, CT 06067 USA	Phone +1-888-892-2694
Website	www.stormtech.com	
E-mail	info@stormtech.com	

Verified Performance Claims

The StormTech Isolator® Row PLUS technology was tested at the Mid-Atlantic Storm Water Research Center (MASWRC), under the supervision of Boggs Environmental Consultants, Inc. The performance test results for two overlapping StormTech Isolator® Row PLUS chambers (commercial unit model SC-740) were verified by Good Harbour Laboratories Inc. (GHL), following the requirements of ISO 14034:2016 and the VerifiGlobal Performance Verification Protocol. Based on the laboratory testing conducted, the verified performance claims are as follows:

Total Suspended Solids (TSS) Removal Efficiency - The StormTech Isolator® Row PLUS achieved $82\% \pm 1\%$ removal efficiency of suspended sediment concentration (SCC) at a 95% confidence level.

Average Loading Rate - Based on the reported flow rate data and the effective sedimentation and filtration treatment area of the test unit, the average loading rate of the test unit was 4.15 ± 0.03 GPM/ft² at a 95% confidence level.

Maximum Treatment Flow Rate (MTFR) - Although the MTFR varies among the StormTech Isolator® Row PLUS model sizes and the number of chambers, the design surface loading rate remains the same (4.13 gpm/ ft² of treatment surface area). The test unit consisted of two overlapping StormTech SC-740 chambers with a nominal MTFR of 225 GPM (0.501 CFS) and an effective filtration treatment area (EFTA) of approximately 54.5 ft².

Detention Time and Volume - The StormTech Isolator Row PLUS detention time and wet volume varies with model size. The unit tested had a wet volume of approximately 65.1 ft³ and a detention time of 2.2 minutes.

Maximum Sediment Storage Depth and Volume - The sediment storage volume and depth vary according to the StormTech Isolator® Row PLUS model sizes and system configuration. For the two overlapping StormTech SC-740 chambers tested, the maximum sediment storage volume is 2.3 ft³ at a sediment depth of 0.5 inches.

Effective Sedimentation/Filtration Treatment Areas - The Effective Sedimentation Area (ESA) and the Effective Filtration Treatment Area (EFTA) increase as the size of the system increases. For the two overlapping StormTech SC-740 chambers tested, the ESA and the ratio of ESA/EFTA were 54.5 ft² and 1.0, respectively.

Sediment Mass Load Capacity - The sediment mass load capacity varies according to the StormTech Isolator® Row PLUS model sizes and system configuration. For the two overlapping StormTech SC-740 chambers tested, the mass loading capture was 158.4 lbs ± 0.8 lbs (2.91 ± 0.01 lbs/ ft²) following a total sediment loading of 195.2 lbs.

Technology Application

The StormTech “Isolator® Row PLUS” is a stormwater treatment technology designed for use under parking lots, roadways and heavy earth loads while providing a superior and durable structural system. The technology comprises a row of chambers covered in a non-woven geotextile fabric with a single layer of proprietary woven fabric at the bottom that serves as a filter strip, providing surface area for infiltration and runoff reduction with enhanced suspended solids and pollutant removal. The following features make the Isolator® Row PLUS effective as a water quality solution:

- Enhanced infiltration Surface Area
- Runoff Volume Reduction
- Peak Flow Reduction
- Sediment/Pollutant Removal
- Internal Water Storage (IWS)
- Water Temperature Cooling (Thermal Buffer).

Technology Description

The Isolator® Row PLUS (shown in Figures 1 and 2) is the first row of StormTech chambers that is surrounded with filter fabric and connected to a closely located manhole for easy access. The Isolator® Row PLUS provides for settling and filtration of sediment as stormwater rises in the chamber and ultimately passes through the filter fabric. The open-bottom chambers allow stormwater to flow out of the chambers, while sediment is captured in the Isolator® Row PLUS.

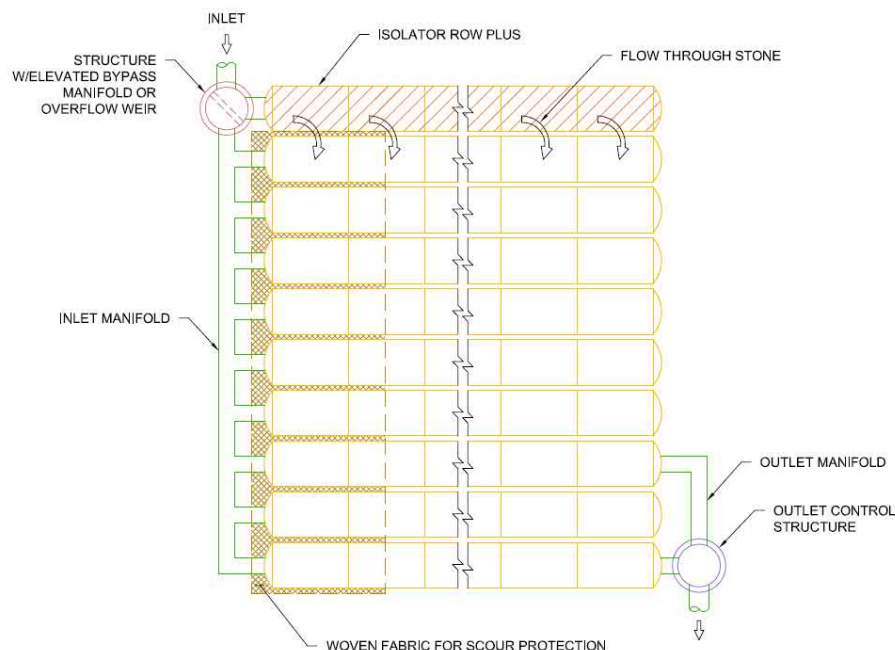

Figure 1: Schematic of the StormTech Isolator® Row PLUS System

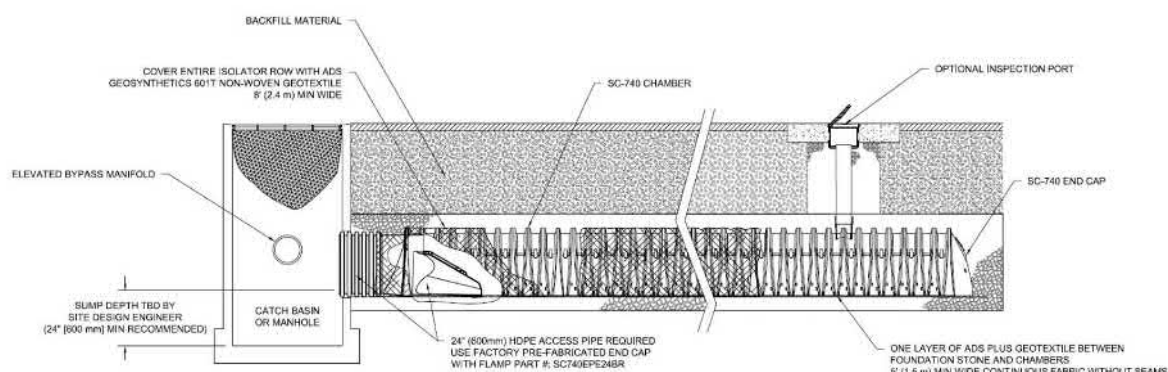

Figure 2: Isolator® Row PLUS Detail

A single layer of proprietary Advanced Drainage Systems (ADS) PLUS fabric is placed between the angular base stone and the Isolator Row PLUS chamber. The geotextile provides the means for stormwater filtration and provides a durable surface for maintenance operations. A 6 oz. non-woven fabric is placed over the chambers.

The Isolator® Row PLUS is designed to capture the “first flush” and offers the versatility to be sized on a volume basis or a flow-rate basis. An upstream manhole not only provides access to the Isolator® Row PLUS but includes a high low/concept such that stormwater flow rates or volumes that exceed the capacity of the Isolator® Row PLUS bypass through a manifold to the other chambers. This is achieved with either a high-flow weir or an elevated manifold. This creates a differential between the Isolator® Row PLUS and the manifold, thus allowing for settlement time in the Isolator® Row PLUS. After Stormwater flows through the Isolator® Row PLUS and into the rest of the StormTech chamber system it is either infiltrated into the soils below or passed at a controlled rate through an outlet manifold and outlet control structure.

StormTech developed and owns the Isolator® Row PLUS technology and has filed a number of patent applications relating to the Isolator® Row PLUS system.¹

Description of Test Procedure for the StormTech Isolator® Row PLUS

In January 2020, two overlapping StormTech SC-740 Isolator® Row PLUS commercial size chambers were installed at the Mid-Atlantic Storm Water Research Center (MASWRC, a subsidiary of BaySaver), in Mount Airy, Maryland, to evaluate the performance of the Isolator® Row PLUS system for Total Suspended Solid (TSS) removal (Figure 3) All testing and data collection procedures were supervised by Boggs Environmental Consultants, Inc. (BEC), who was hired by ADS for third party oversight, and were in accordance with the *New Jersey Department of Environmental Protection Laboratory Protocol to Assess Total Suspended Solids Removal by a Filtration Manufactured Treatment Device (January 2013)*.

Prior to the start of testing, a Quality Assurance Project Plan (QAPP), revision dated January 09, 2020, was submitted and approved by the New Jersey Corporation for Advanced Technology (NJCAT), c/o Center for Environmental Systems, Stevens Institute of Technology, Castle Point on Hudson, Hoboken, NJ 07030.

¹ (U.S. Provisional Application No. 62/753,050, filed October 30, 2018; U.S. Non-Provisional Application No. 16/670,628, filed October 31, 2019; International Application No. PCT/US2019/059283, filed October 31, 2019; U.S. Application No. 16/938,482, filed July 24, 2020; U.S. Application No. 16/938,657, filed July 24, 2020; PCT International Application No. PCT/US2020/043543, filed July 24, 2020; PCT International Application No. PCT/US2020/043557, filed July 24, 2020.

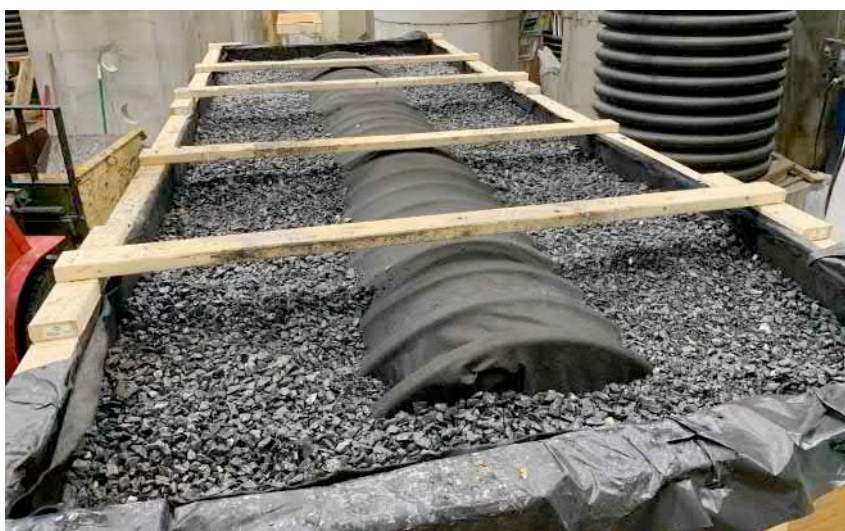

Figure 3: StormTech “Isolator® Row PLUS” Test Set-up at MASWRC

Verification Results

The verification process for the StormTech Isolator® Row PLUS technology was conducted by GHIL in accordance with the VerifiGlobal Verification Plan for the StormTech “Isolator® Row PLUS” Technology – 2020-09-09. The technology performance claims verified by GHIL are summarized at the front of this Verification Statement and in Table 6 on Page 8 under the heading “Verification Summary”.

Particle size distribution analysis was performed by ECS Mid-Atlantic, LLC of Frederick, MD in accordance with ASTM D422-63(2007). ECS is accredited by the American Association of State Highways and Transportation Officials (AASHTO).

ASTM D422-63(2007) is a sieve and hydrometer method where the larger particles, > 75 microns, are measured using a standard sieve stack while the smaller particles are measured based on their settling time using a hydrometer.

The PSD meets the requirements of NJDEP, which is generally accepted as representative of the type of particle sizes an OGS would be designed to treat. Actual PSD is site and rainfall event specific, so it was necessary to choose a standard PSD to make testing and comparison manageable.

Table 1 shows the NJDEP PSD specification. Table 2 and Figure 4 show the incoming material PSD as determined by ECS Mid-Atlantic and confirmed by the verifier.

Table 1: NJDEP PSD Specification

Particle Size (µm)	NJDEP Minimum Specification
1000	98
500	93
250	88
150	73
100	58
75	48
50	43
20	33
8	18
5	8
2	3
d ₅₀	< 75 µm

Table 2 – Particle Size Distribution (PSD) of Test Sediment

Mesh (mm)	US Sieve Size	Sample ID		
		PSD A	PSD B	PSD C
		Percent Finer		
9.525	0.375	100.0	100.0	100.0
4.750	#4	100.0	100.0	100.0
4.000	#5	100.0	100.0	100.0
2.360	#8	100.0	100.0	100.0
2.000	#10	100.0	100.0	100.0
1.180	#16	100.0	100.0	100.0
1.000	#18	100.0	100.0	100.0
0.500	#35	100.0	100.0	100.0
0.425	#40	93.3	93.0	93.6
0.250	#60	90.3	89.8	90.2
0.150	#100	79.3	78.1	78.1
0.125	#120	73.6	71.7	71.7
0.106	#140	68.4	65.2	64.8
0.090	#170	60.2	58.3	57.5
0.075	#200	52.0	50.9	50.3
0.053	#270	48.0	48.3	47.8
0.045	Hydrometer	46.6	46.7	46.7
0.032		42.8	42.9	41.0
0.021		37.1	37.2	35.3
0.0125		25.7	25.7	25.8
0.0090		20.1	20.1	19.2
0.0064		16.3	16.4	14.5
0.0032		8.8	8.7	7.8
0.0014		3.8	3.7	3.8

The suspended sediment concentration analysis was completed by Fredericktowne Labs Inc., Myersville, MD. Fredericktowne Labs is accredited by the Maryland Department of Environment as Maryland Certified Water Quality Laboratory. The analysis procedure was ASTM D3977-97, Suspended Sediment Concentration. The sampling procedure and submission of samples to the test lab were overseen by the independent observer, Boggs Environmental Consultants, Inc.

All test data and calculations were detailed in the report “NJCAT TECHNOLOGY VERIFICATION Isolator® Row PLUS StormTech, LLC”, July 2020, which was submitted to and verified by the New Jersey Corporation for Advanced Technology (NJCAT).

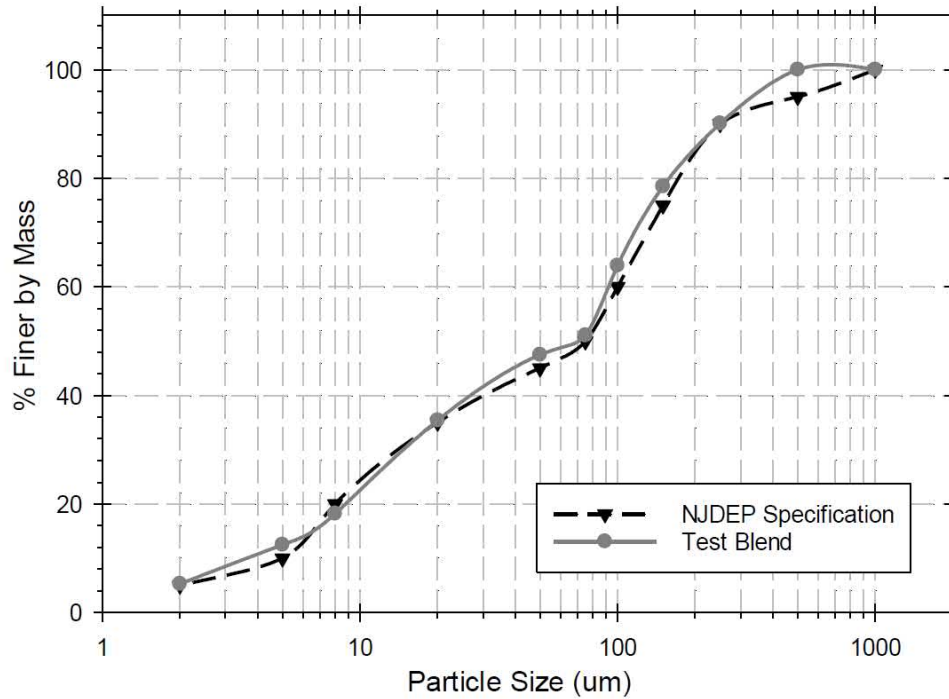

Figure 4– Particle Size Distribution (PSD)

The data in Table 3 (Flow Rate and Temperature) and Table 4 (Removal Efficiency) form the basis for the verified technology performance claim, specifically, flow rate, sediment captured and removal efficiency.

Table 3: Flow Rate and Temperature Summary

Run	Max Flow (gpm)	Min Flow (gpm)	Average Flow (gpm)	Flow COV	Flow Compliance (COV < 0.1)	Maximum Temperature (Fahrenheit)	NJDEP Temperature Compliance (< 80 F)
1	232.8	223.9	226.3	0.0078	Y	48.2	Y
2	228.9	218.6	220.8	0.0104	Y	51.5	Y
3	229.4	220.0	227.2	0.0094	Y	44.7	Y
4	230.2	218.7	223.2	0.0138	Y	40.5	Y
5	228.7	216.9	222.2	0.0103	Y	44.7	Y
6	227.6	217.0	224.2	0.0115	Y	46.7	Y
7	229.7	221.9	226.4	0.0092	Y	44.6	Y
8	230.3	222.2	226.8	0.0089	Y	43.5	Y
9	233.2	218.4	225.6	0.0136	Y	45.5	Y
10	232.2	219.7	228.4	0.0126	Y	44.7	Y
11	226.9	219.2	224.1	0.0088	Y	52.4	Y
12	232.2	222.1	226.9	0.0107	Y	48.5	Y
13	234.7	221.2	226.1	0.0109	Y	48.5	Y
14	231.9	223.4	228.7	0.0103	Y	45.6	Y
15	236.8	224.1	231.4	0.0131	Y	52.2	Y
16	232.5	221.3	229.0	0.0137	Y	47.8	Y

Table 4: Removal Efficiency Results

Run	Average Influent TSS (mg/L)	Influent Water Volume (gal)	Adjusted Average Effluent TSS (mg/L)	Effluent Water Volume (gal)	Adjusted Average Drain Down TSS (mg/L)	Drain Down Water Volume (gal)	Single Run Removal Efficiency (%)	Mass of Captured Sediment (g)	Cumulative Removal Efficiency (%)
1	203	7166	46	6881	34	285	77.8	4282	77.8
2	199	6993	32	6639	27	354	84.0	4415	80.8
3	207	7197	37	6793	27	403	82.6	4654	81.4
4	217	7068	33	6635	29	433	84.9	4923	82.3
5	215	7037	39	6593	29	444	82.2	4705	82.3
6	207	7097	40	6643	31	454	81.2	4504	82.1
7	198	7169	37	6693	30	476	81.6	4386	82.0
8	201	7184	37	6716	32	468	81.6	4473	82.0
9	205	7147	38	6675	30	472	81.8	4539	82.0
10	203	7235	38	6759	31	476	81.4	4523	81.9
11	208	7096	38	6624	30	472	81.8	4567	81.9
12	209	7185	41	6709	30	476	80.7	4584	81.8
13	198	7162	41	6680	32	482	79.7	4277	81.6
14	200	7242	43	6757	34	485	78.8	4318	81.4
15	196	7329	41	6842	32	487	79.5	4320	81.3
16	202	7254	44	6769	31	485	78.9	4384	81.2
Avg.	204.2	7160	39	6713	31	447	81.2	4491	N/A
Cumulative Mass Removed (g)							71854		
Cumulative Mass Removed (lb)							158.4		
Total Mass Loaded (lb)							195.2		
Cumulative Removal Efficiency (%)							81.2		

Quality Assurance

Performance verification of the StormTech Isolator® Row PLUS technology was performed in accordance with the requirements of ISO 14034:2016 and the VerifiGlobal Performance Verification Protocol. This included reviewing all data sheets and calculated values, as well as overall management of the test system, quality control and data integrity.

Additional information on quality control measures taken can be found in section 5 of the QAPP for StormTech Isolator Row New Jersey Department of Environmental Protection Testing, Rev. 1/9/2020.

Specific QA/QC measures reviewed by the verifier are summarized in Table 5 below.

Table 5. Validation of QA/QC Procedures

QC Parameter	Acceptance Criteria
Independence of observer	Confirmed in letter from Boggs Environmental Consultants, Inc. to NJCAT
Consistency of procedure	Daily logs confirm proper procedure
Existence of QAPP	Confirmed. "QAPP For StormTech Isolator Row New Jersey Department of Environmental Protection Testing", Rev. 1/9/2020)
Use of appropriate sample analysis method – ASTM D3799	Confirmed by method reference on lab reports from Fredericktowne Labs Inc.
Test method appropriate for the technology	Used industry stakeholder approved protocol: <i>New Jersey Department of Environmental Protection Laboratory Protocol to Assess Total Suspended Solids</i>



	<i>Removal by a Filtration Manufactured Treatment Device (January 2013)</i>
Test parameters stayed within required limits	Confirmed in report “NJCAT TECHNOLOGY VERIFICATION Isolator® Row PLUS StormTech, LLC”, July 2020
Third party verified data	All testing was observed and reviewed by Boggs Environmental Consultants, Inc.

Variance

Performance claims regarding structural load limitations were not verified as they are outside the scope of the performance testing that was conducted in accordance with the ‘Quality Assurance Project Plan (QAPP) for StormTech Isolator Row, New Jersey Department of Environmental Protection Testing’, revision dated January 09, 2020.

Verification Summary

The StormTech “Isolator® Row PLUS” is a stormwater treatment technology designed for use under parking lots, roadways and heavy earth loads while providing a superior and durable structural system. The technology comprises a row of chambers wrapped in woven geotextile fabric with two layers at the bottom that serve as a filter strip, providing surface area for infiltration and runoff reduction with enhanced suspended solids and pollutant removal.

The StormTech Isolator® Row PLUS technology was tested at the Mid-Atlantic Storm Water Research Center (MASWRC), under the supervision of Boggs Environmental Consultants, Inc. The performance test results for two overlapping StormTech Isolator® Row PLUS chambers (commercial unit model SC-740) were verified by Good Harbour Laboratories Inc. (GHL), following the requirements of ISO 14034:2016 and the VerifiGlobal Performance Verification Protocol. Table 6 summarizes the verification results in relation to the technology performance parameters that were identified in the Verification Plan to determine the efficacy of the StormTech Isolator® Row PLUS technology.

Table 6 - Summary of Verification Results Against Performance Parameters

Parameters	Verified Claims	Accuracy
Total Suspended Solids (TSS) Removal Efficiency	Based on the laboratory testing conducted, the StormTech Isolator® Row PLUS achieved an average 82% removal efficiency of SSC	± 1% (95% confidence level)
Average Loading Rate	Based on the laboratory testing parameters, the StormTech Isolator® Row PLUS maintained a loading rate of 4.15 GPM/sf	±0.03 GPM/sf (95% confidence level)
Maximum Treatment Flow Rate (MTFR)	Although the MTFR varies among the StormTech Isolator® Row PLUS model sizes and the number of chambers, the design surface loading rate remains the same (4.13 GPM/ft ² of treatment surface area). The test unit consisted of two overlapping StormTech SC-740 chambers with a nominal MTFR of 225 GPM (0.501 CFS) and an effective filtration treatment area (EFTA) of approximately 54.5 ft ² .	± 1.4 GPM (95% confidence level)
Detention Time and Volume	Detention time and wet volume varies with model size. The unit tested had a wet volume of approximately 65.1 ft ³ (based on	N/A

	physical measurement) and a detention time of 2.2 minutes.	
Maximum Sediment Storage Depth and Volume	The sediment storage volume and depth vary according to the StormTech Isolator® Row PLUS model sizes and system configuration. For the two overlapping StormTech SC-740 chambers tested, the maximum sediment storage volume is 2.3 ft ³ at a sediment depth of 0.5 inches.	N/A
Effective Sedimentation/ Filtration Treatment Area	The effective sedimentation and filtration treatment area increases as the size of the chamber increases. Under the tested conditions using 2 overlapping chambers, the treatment area was 54.5 ft ²	The sedimentation /filtration area was determined from the actual physical dimensions of the test unit*
Sediment Mass Load Capacity	The sediment mass load capacity varies according to the StormTech Isolator® Row PLUS model sizes and system configuration. For the two overlapping StormTech SC-740 chambers tested, the mass loading capture was 158.4 lbs (2.91 lbs/ ft ²) following a total sediment loading of 195.2 lbs	± 0.8 lbs (±0.01 lbs/ft ²) (95% confidence level)

*Note: These numbers are determined based on physical measurement or a dimensional drawing, which is standard practice. Highly accurate measurements are not practical.

In conclusion, the StormTech Isolator® Row PLUS is a viable technology that can be used to remove contaminants from stormwater runoff via filtration. This technology has proven effective at removing suspended sediment from stormwater through in-lab testing using an industry recognized laboratory protocol.

By extension of sediment removal, this technology should also remove particle bound nutrients, heavy metals, and a wide variety of organic contaminants. Performance is a function of pollutant properties, hydraulic retention time, filter media, pre-treatment, and flow rate, such that proper design of the system is critical to achieving the desired results.

What is ISO 14034?

The purpose of environmental technology verification is to provide a credible and impartial account of the performance of environmental technologies. Environmental technology verification is based on a number of principles to ensure that verifications are performed and reported accurately, clearly, unambiguously and objectively. The International Organization for Standardization (ISO) standard for environmental technology verification (ETV) is ISO 14034, which was published in November 2016.



Benefits of ETV

ETV contributes to protection and conservation of the environment by promoting and facilitating market uptake of innovative environmental technologies, especially those that perform better than relevant alternatives. ETV is particularly applicable to those environmental technologies whose innovative features or performance cannot be fully assessed using existing standards. Through the provision of objective evidence, ETV provides an independent and impartial confirmation of the performance of an environmental technology based on reliable test data. ETV aims to strengthen the credibility of new, innovative technologies by supporting informed decision-making among interested parties.

For more information on the StormTech “Isolator® Row PLUS” technology, contact:	For more information on VerifiGlobal, contact:
StormTech, LLC. 520 Cromwell Avenue, Rocky Hill, CT 06067 USA t: +1-888-892-2694 e: info@stormtech.com w: www.stormtech.com	VerifiGlobal c/o ETA-Danmark A/S Göteborg Plads 1, DK-2150 Nordhaven t +45 7224 5900 e: info@verifiglobal.com w: www.verifiglobal.com
Signed for StormTech: <i>Original signed by:</i> <i>Greg Spires</i> Greg Spires, P.E. General Manager	Signed for VerifiGlobal: <i>Original signed by:</i> <i>Thomas Bruun</i> Thomas Bruun, Managing Director <i>Original signed by:</i> <i>John Neate</i> John Neate, Managing Director

NOTICE: Verifications are based on an evaluation of technology performance under specific, predetermined operational conditions and parameters and the appropriate quality assurance procedures. VerifiGlobal and the Verification Expert, Good Harbour Laboratories, make no expressed or implied warranties as to the performance of the technology and do not certify that a technology will always operate as verified. The end user is solely responsible for complying with any and all applicable regulatory requirements. Mention of commercial product names does not imply endorsement.

VerifiGlobal and the Verification Expert, Good Harbour Laboratories, provide the verification services solely on the basis of the information supplied by the applicant or vendor and assume no liability thereafter. The responsibility for the information supplied remains solely with the applicant or vendor and the liability for the purchase, installation, and operation (whether consequential or otherwise) is not transferred to any other party as a result of the verification.

VERIFICATION STATEMENT

GLOBE Performance Solutions

Verifies the performance of

Stormceptor® EF and EFO Oil-Grit Separators

Developed by Imbrium Systems, Inc.,
Whitby, Ontario, Canada

Registration: GPS-ETV_VR2023-11-15_Imbrium-SC

In accordance with

ISO 14034:2016

**Environmental management —
Environmental technology verification (ETV)**



John D. Wiebe, PhD
Executive Chairman
GLOBE Performance Solutions

November 15, 2023
Vancouver, BC, Canada



Verification Body
GLOBE Performance Solutions
404 – 999 Canada Place | Vancouver, B.C | Canada |V6C 3E2

Technology description and application

The Stormceptor® EF and EFO are treatment devices designed to remove oil, sediment, trash, debris, and pollutants attached to particulates from Stormwater and snowmelt runoff. The device takes the place of a conventional manhole within a storm drain system and offers design flexibility that works with various site constraints. The EFO is designed with a shorter bypass weir height, which accepts lower surface loading rate into the sump, thereby reducing re-entrainment of captured free floating light liquids.

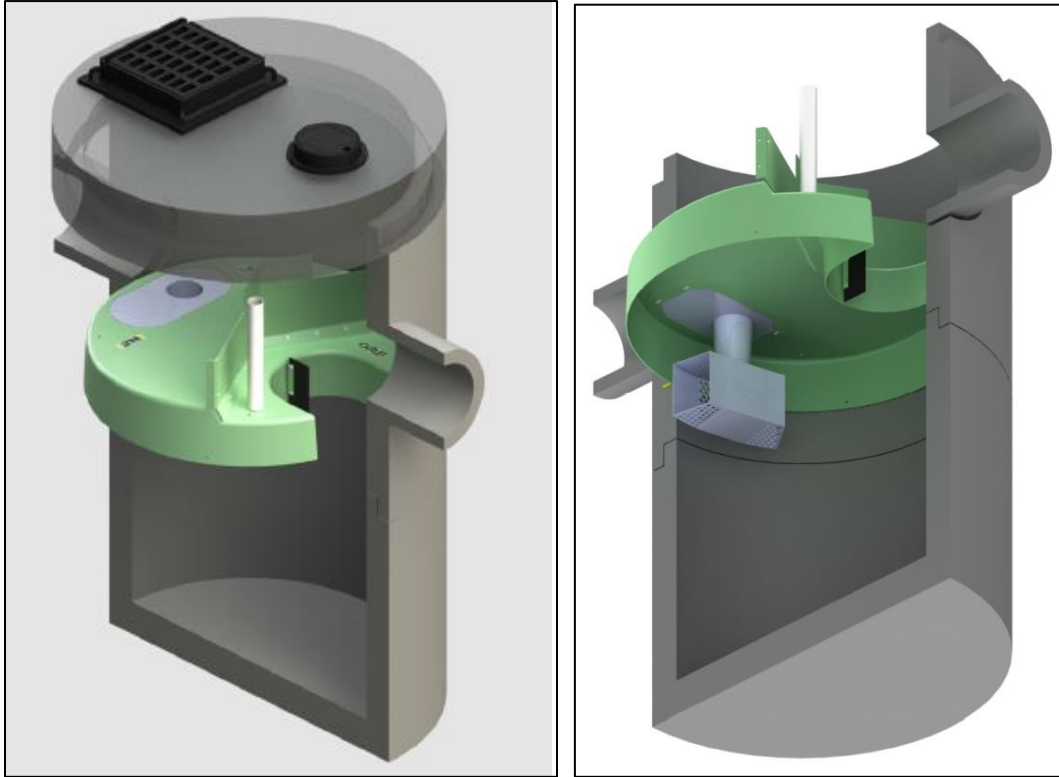

Figure 1. Graphic of typical inline Stormceptor® unit and core components.

Stormwater and snowmelt runoff enters the Stormceptor® EF/EFO's upper chamber through the inlet pipe(s) or a surface inlet grate. An insert divides the unit into lower and upper chambers and incorporates a weir to reduce influent velocity and separate influent (untreated) from effluent (treated) flows. Influent water ponds upstream of the insert's weir providing driving head for the water flowing downwards into the drop pipe where a vortex pulls the water into the lower chamber. The water diffuses at lower velocities in multiple directions through the drop pipe outlet openings. Oil and other floatables rise up and are trapped beneath the insert, while sediments undergo gravitational settling to the sump's bottom. Water from the sump can exit by flowing upward to the outlet riser onto the top side of the insert and downstream of the weir, where it discharges through the outlet pipe.

Maximum flow rate into the lower chamber is a function of weir height and drop pipe orifice diameter. The Stormceptor® EF and EFO are designed to allow a surface loading rate of 1135 L/min/m² (27.9 gal/min/ft²) and 535 L/min/m² (13.1 gal/min/ft²) into the lower chamber, respectively. When prescribed surface loading rates are exceeded, ponding water can overtop the weir height and bypass the lower treatment chamber, exiting directly through the outlet pipe. Hydraulic testing and scour testing demonstrate that the internal bypass effectively prevents scour at all bypass flow rates. Increasing the bypass flow rate does not increase the orifice-controlled flow rate into the lower treatment chamber where sediment is stored. This internal bypass feature allows for in-line installation, avoiding the cost of

additional bypass structures. During bypass, treatment continues in the lower chamber at the maximum flow rate. The Stormceptor® EFO's lower design surface loading rate is favorable for minimizing re-entrainment and washout of captured light liquids. Inspection of Stormceptor® EF and EFO devices is performed from grade by inserting a sediment probe through the outlet riser and an oil dipstick through the oil inspection pipe. The unit can be maintained by using a vacuum hose through the outlet riser.

Performance conditions

The data and results published in this Technology Fact Sheet were obtained from the testing program conducted on the Imbrium Systems Inc.'s Stormceptor® EF4 and EFO4 Oil-Grit Separators, in accordance with the Procedure for Laboratory Testing of Oil-Grit Separators (Version 3.0, June 2014). The Procedure was prepared by the Toronto and Region Conservation Authority (TRCA) for Environment Canada's Environmental Technology Verification (ETV) Program. A copy of the Procedure may be accessed on the Canadian ETV website at www.etvcanada.ca.

Performance claim(s)

Capture test^a:

During the capture test, the Stormceptor® EF4 OGS device, with a false floor set to 50% of the manufacturer's recommended maximum sediment storage depth and a constant influent test sediment concentration of 200 mg/L, removes 70, 64, 54, 48, 46, 44, and 49 percent of influent sediment by mass at surface loading rates of 40, 80, 200, 400, 600, 1000, and 1400 L/min/m², respectively.

Stormceptor® EFO4, with a false floor set to 50% of the manufacturer's recommended maximum sediment storage depth and a constant influent test sediment concentration of 200 mg/L, removes 70, 64, 54, 48, 42, 40, and 34 percent of influent sediment by mass at surface loading rates of 40, 80, 200, 400, 600, 1000, and 1400 L/min/m², respectively.

Scour test^a:

During the scour test, the Stormceptor® EF4 and Stormceptor® EFO4 OGS devices, with 10.2 cm (4 inches) of test sediment pre-loaded onto a false floor reaching 50% of the manufacturer's recommended maximum sediment storage depth, generate corrected effluent concentrations of 4.6, 0.7, 0, 0.2, and 0.4 mg/L at 5-minute duration surface loading rates of 200, 800, 1400, 2000, and 2600 L/min/m², respectively.

Light liquid re-entrainment test^a:

During the light liquid re-entrainment test, the Stormceptor® EFO4 OGS device with surrogate low-density polyethylene beads preloaded within the lower chamber oil collection zone, representing a floating light liquid volume equal to a depth of 50.8 mm over the sedimentation area, retained 100, 99.5, 99.8, 99.8, and 99.9 percent of loaded beads by mass during the 5-minute duration surface loading rates of 200, 800, 1400, 2000, and 2600 L/min/m².

^a The claim can be applied to other units smaller or larger than the tested unit as long as the untested units meet the scaling rule specified in the Procedure for Laboratory of Testing of Oil Grit Separators (Version 3.0, June 2014)

Performance results

The test sediment consisted of ground silica (1 – 1000 micron) with a specific gravity of 2.65, uniformly mixed to meet the particle size distribution specified in the testing procedure. The *Procedure for Laboratory Testing of Oil Grit Separators* requires that the three sample average of the test sediment particle size distribution (PSD) meet the specified PSD percent less than values within a boundary threshold of 6%. The comparison of the average test sediment PSD to the CETV specified PSD in Figure 2 indicates that the test sediment used for the capture and scour tests met this condition.

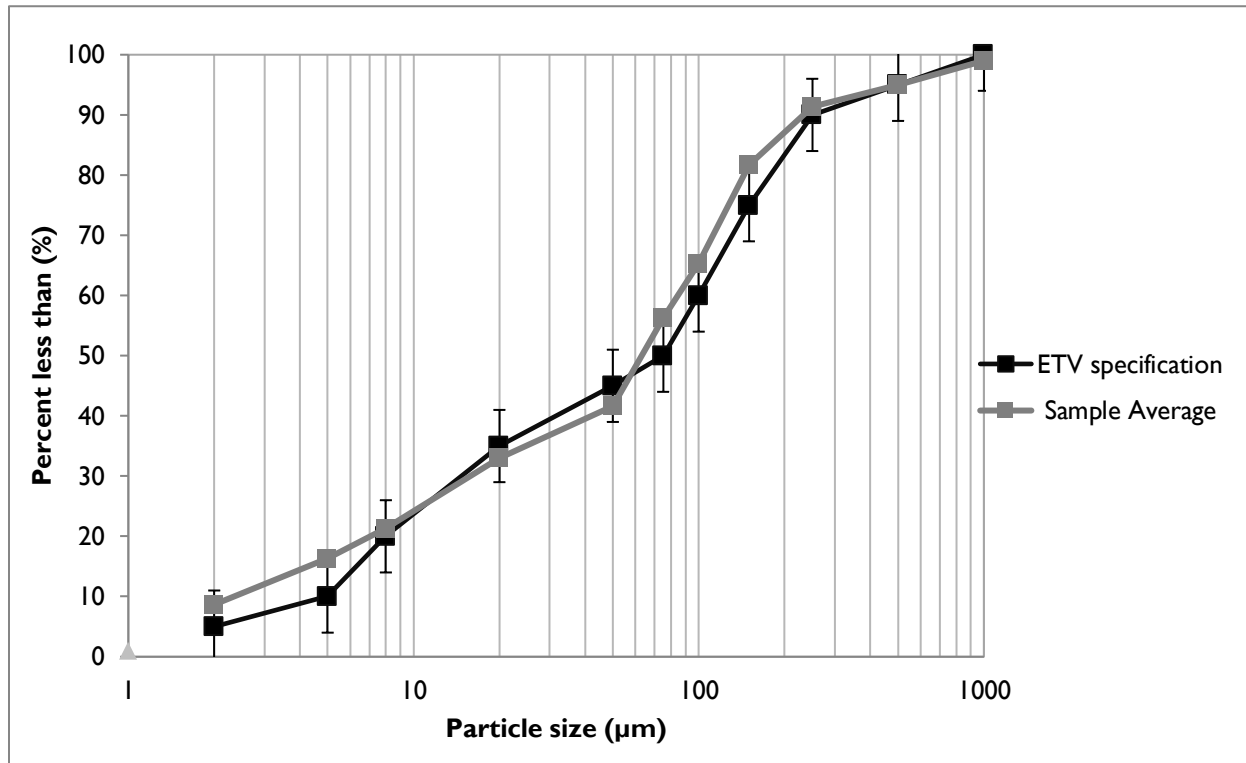

Figure 2. The three sample average particle size distribution (PSD) of the test sediment used for the capture and scour test compared to the specified PSD.

The capacity of the device to retain sediment was determined at seven surface loading rates using the modified mass balance method. This method involved measuring the mass and particle size distribution of the injected and retained sediment for each test run. Performance was evaluated with a false floor simulating the technology filled to 50% of the manufacturer’s recommended maximum sediment storage depth. The test was carried out with clean water that maintained a sediment concentration below 20 mg/L. Based on these conditions, removal efficiencies for individual particle size classes and for the test sediment as a whole were determined for each of the tested surface loading rates (Table 1). Since the EF and EFO models are identical except for the weir height, which bypasses flows from the EFO model at a surface loading rate of 535 L/min/m² (13.1 gpm/ft²), sediment capture tests at surface loading rates from 40 to 400 L/min/m² were only performed on the EF unit. Surface loading rates of 600, 1000, and 1400 L/min/m² were tested on both units separately. Results for the EFO model at these higher flow rates are presented in Table 2.

In some instances, the removal efficiencies were above 100% for certain particle size fractions. These discrepancies are not unique to any one test laboratory and may be attributed to errors relating to the blending of sediment, collection of representative samples for laboratory submission, and laboratory

analysis of PSD. Due to these errors, caution should be exercised in applying the removal efficiencies by particle size fraction for the purposes of sizing the tested device (see [Bulletin # CETV 2016-11-0001](#)). The results for “all particle sizes by mass balance” (see Table 1 and 2) are based on measurements of the total injected and retained sediment mass, and are therefore not subject to blending, sampling or PSD analysis errors.

Table 1. Removal efficiencies (%) of the EF4 at specified surface loading rates

Particle size fraction (µm)	Surface loading rate (L/min/m ²)						
	40	80	200	400	600	1000	1400
>500	90	58	58	100*	86	72	100*
250 - 500	100*	100*	100	100*	100*	100*	100*
150 - 250	90	82	26	100*	100*	67	90
105 - 150	100*	100*	100*	100*	100*	100*	100
75 - 105	100*	92	74	82	77	68	76
53 - 75	Undefined ^a	56	100*	72	69	50	80
20 - 53	54	100*	54	33	36	40	31
8 - 20	67	52	25	21	17	20	20
5 – 8	33	29	11	12	9	7	19
<5	13	0	0	0	0	0	4
All particle sizes by mass balance	70.4	63.8	53.9	47.5	46.0	43.7	49.0

^a An outlier in the feed sample sieve data resulted in a negative removal efficiency for this size fraction.

* Removal efficiencies were calculated to be above 100%. Calculated values ranged between 101 and 171% (average 128%). See text and [Bulletin # CETV 2016-11-0001](#) for more information.

Table 2. Removal efficiencies (%) of the EFO4 at surface loading rates above the bypass rate of 535 L/min/m²

Particle size fraction (µm)	Surface loading rate (L/min/m ²)		
	600	1000	1400
>500	89	83	100*
250 - 500	90	100*	92
150 - 250	90	67	100*
105 - 150	85	92	77
75 - 105	80	71	65
53 - 75	60	31	36
20 - 53	33	43	23
8 - 20	17	23	15
5 – 8	10	3	3
<5	0	0	0
All particle sizes by mass balance	41.7	39.7	34.2

* Removal efficiencies were calculated to be above 100%. Calculated values ranged between 103 and 111% (average 107%). See text and [Bulletin # CETV 2016-11-0001](#) for more information.

Figure 3 compares the particle size distribution (PSD) of the three sample average of the test sediment to the PSD of the sediment retained by the EF4 at each of the tested surface loading rates. Figure 4 shows the same graph for the EFO4 unit at surface loading rates above the bypass rate of 535 L/min/m².

As expected, the capture efficiency for fine particles in both units was generally found to decrease as surface loading rates increased.

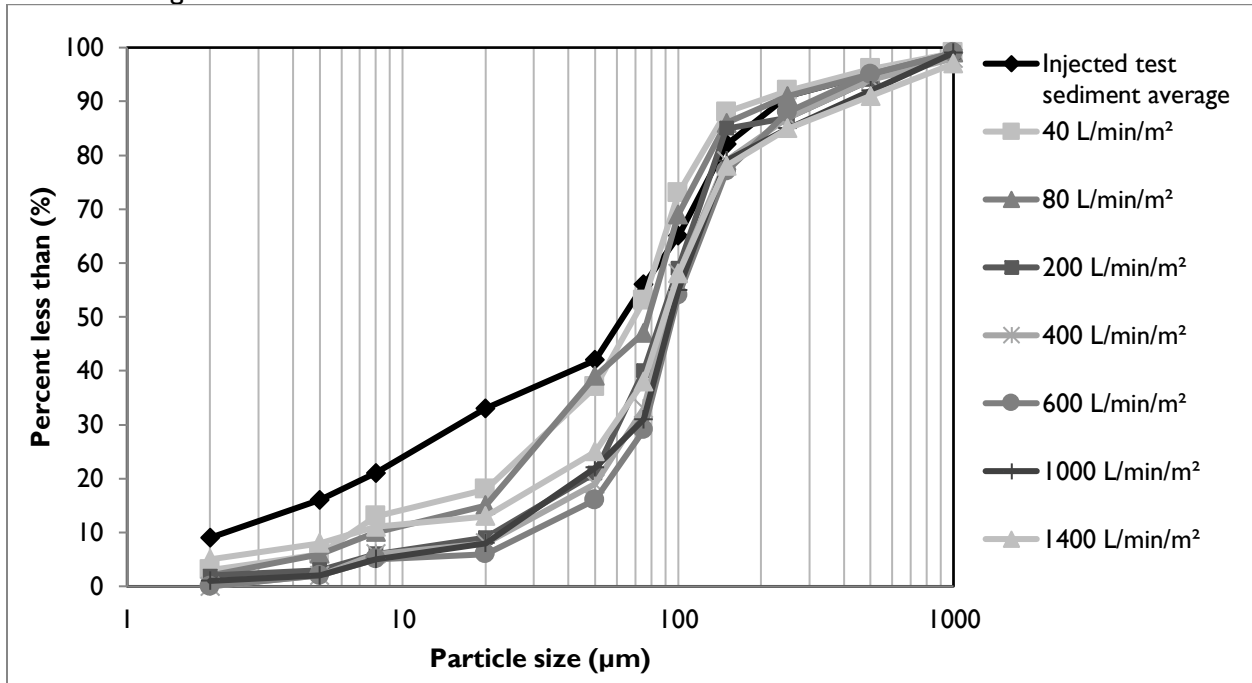

Figure 3. Particle size distribution of sediment retained in the EF4 in relation to the injected test sediment average.

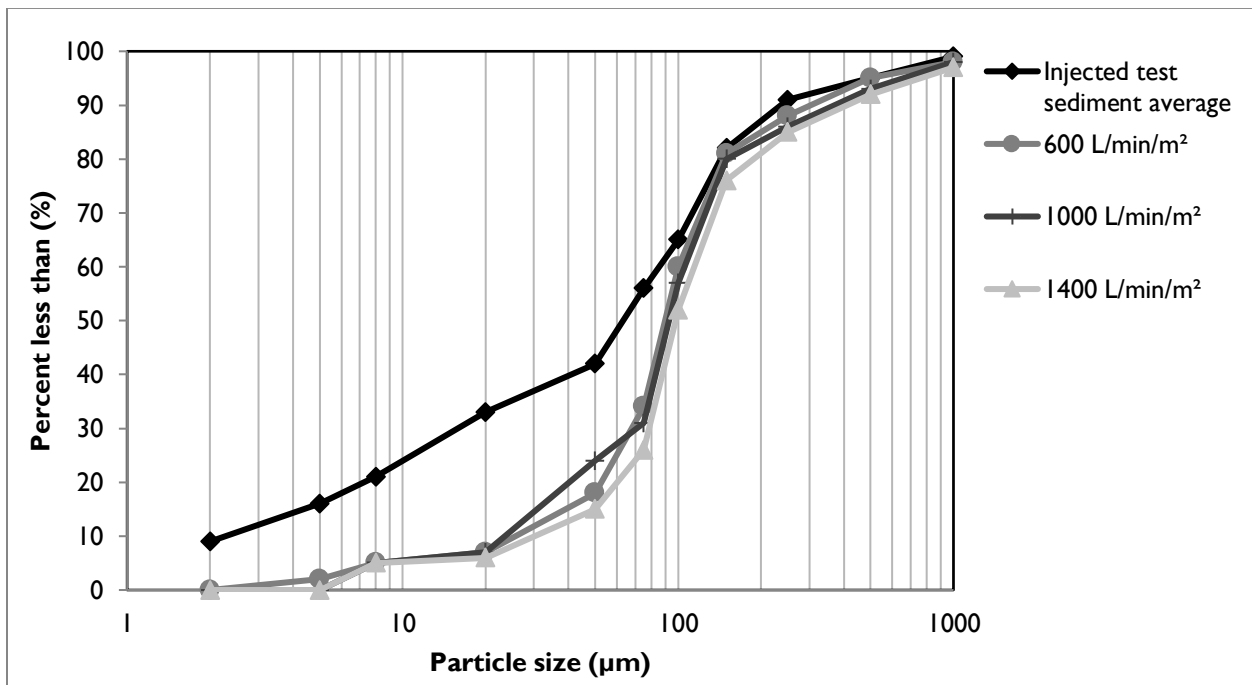

Figure 4. Particle size distribution of sediment retained in the EFO4 in relation to the injected test sediment average at surface loading rates above the bypass rate of 535 L/min/m²

Table 4 shows the results of the sediment scour and re-suspension test for the EF4 unit. The EFO4 was not tested as it was reasonably assumed that scour rates would be lower given that flow bypass occurs at a lower surface loading rate. The scour test involved preloading 10.2 cm of fresh test sediment into

the sedimentation sump of the device. The sediment was placed on a false floor to mimic a device filled to 50% of the maximum recommended sediment storage depth. Clean water was run through the device at five surface loading rates over a 30 minute period. Each flow rate was maintained for 5 minutes with a one minute transition time between flow rates. Effluent samples were collected at one minute sampling intervals and analyzed for Suspended Sediment Concentration (SSC) and PSD by recognized methods. The effluent samples were subsequently adjusted based on the background concentration of the influent water. Typically, the smallest 5% of particles captured during the 40 L/min/m² sediment capture test is also used to adjust the concentration, as per the method described in [Bulletin # CETV 2016-09-0001](#). However, since the composites of effluent concentrations were below the Reporting Detection Limit of the Laser Diffraction PSD methodology, this adjustment was not made. Results showed average adjusted effluent sediment concentrations below 5 mg/L at all tested surface loading rates.

It should be noted that the EF4 starts to internally bypass water at 1135 L/min/m², potentially resulting in the dilution of effluent concentrations, which would not normally occur under typical field conditions because the field influent concentration would contain a much higher sediment concentration than during the lab test. Recalculation of effluent concentrations to account for dilution at surface loading rates above the bypass rate showed sediment effluent concentrations to be below 1.6 mg/L.

Table 4. Scour test adjusted effluent sediment concentration.

Run	Surface loading rate (L/min/m ²)	Run time (min)	Background sample concentration (mg/L)	Adjusted effluent suspended sediment concentration (mg/L) ^a	Average (mg/L)
1	200	1:00	<RDL	11.9	4.6
		2:00		7.0	
		3:00		4.4	
		4:00		2.2	
		5:00		1.0	
		6:00		1.2	
2	800	7:00	<RDL	1.1	0.7
		8:00		0.9	
		9:00		0.6	
		10:00		1.4	
		11:00		0.1	
		12:00		0	
3	1400	13:00	<RDL	0	0
		14:00		0.1	
		15:00		0	
		16:00		0	
		17:00		0	
		18:00		0	
4	2000	19:00	1.2	0.2	0.2
		20:00		0	
		21:00		0	
		22:00		0.7	
		23:00		0	
		24:00		0.4	

5	2600	25:00	1.6	0.3	0.4
		26:00		0.4	
		27:00		0.7	
		28:00		0.4	
		29:00		0.2	
		30:00		0.4	

^a The adjusted effluent suspended sediment concentration represents the actual measured effluent concentration minus the background concentration. For more information see [Bulletin # CETV 2016-09-0001](#).

The results of the light liquid re-entrainment test used to evaluate the unit’s capacity to prevent re-entrainment of light liquids are reported in Table 5. The test involved preloading 58.3 L (corresponding to a 5 cm depth over the collection sump area of 1.17m²) of surrogate low-density polyethylene beads within the oil collection skirt and running clean water through the device continuously at five surface loading rates (200, 800, 1400, 2000, and 2600 L/min/m²). Each flow rate was maintained for 5 minutes with approximately 1 minute transition time between flow rates. The effluent flow was screened to capture all re-entrained pellets throughout the test.

Table 5. Light liquid re-entrainment test results for the EFO4.

Surface Loading Rate (L/min/m ²)	Time Stamp	Amount of Beads Re-entrained			
		Mass (g)	Volume (L) ^a	% of Pre-loaded Mass Re-entrained	% of Pre-loaded Mass Retained
200	62	0	0	0.00	100
800	247	168.45	0.3	0.52	99.48
1400	432	51.88	0.09	0.16	99.83
2000	617	55.54	0.1	0.17	99.84
2600	802	19.73	0.035	0.06	99.94
Total Re-entrained		295.60	0.525	0.91	--
Total Retained		32403	57.78	--	99.09
Total Loaded		32699	58.3	--	--

^a Determined from bead bulk density of 0.56074 g/cm³

Variations from testing Procedure

The following minor deviations from the *Procedure for Laboratory Testing of Oil-Grit Separators* (Version 3.0, June 2014) have been noted:

1. During the capture test, the 40 L/min/m² and 80 L/min/m² surface loading rates were evaluated over 3 and 2 days respectively due to the long duration needed to feed the required minimum of 11.3 kg of test sediment into the unit at these lower flow rates. Pumps were shut down at the end of each intermediate day, and turned on again the following morning. The target flow rate was re-established within 30 seconds of switching on the pump. This procedure may have allowed sediments to be captured that otherwise may have exited the unit if the test was continuous. On the basis of practical considerations, this variance was approved by the verifier prior to testing.

2. During the scour test, the coefficient of variation (COV) for the lowest flow rate tested (200 L/min/m²) was 0.07, which exceeded the specified limit of 0.04 target specified in the OGS Procedure. A pump capable of attaining the highest flow rate of 3036 L/min had difficulty maintaining the lowest flow of 234 L/min but still remained within +/- 10% of the target flow and is viewed as having very little impact on the observed results. Similarly, for the light liquid re-entrainment test the COV for the flow rate of the 200 L/min/m² run was 0.049, exceeding the limit of 0.04, but is believed to introduce negligible bias.
3. Due to pressure build up in the filters, the runs at 1000 L/min/m² for the Stormceptor® EF4 and 1000 and 1400 L/min/m² for the Stormceptor® EFO4 were slightly shorter than the target. The run times were 54, 59 and 43 minutes respectively, versus targets of 60 and 50 minutes. The final feed samples were timed to coincide with the end of the run. Since >25 lbs of sediment was fed, the shortened time did not invalidate the runs.

Verification

The verification was completed by the Verification Expert, Toronto and Region Conservation Authority, contracted by GLOBE Performance Solutions, using the International Standard **ISO 14034:2016 Environmental management – Environmental technology verification (ETV)**. Data and information provided by Imbrium Systems Inc. to support the performance claim included the following: Performance test report prepared by Good Harbour Laboratories, and dated September 8, 2017; the report is based on testing completed in accordance with the Procedure for Laboratory Testing of Oil-Grit Separators (Version 3.0, June 2014).

What is ISO 14034:2016 Environmental management – Environmental technology verification (ETV)?

ISO 14034:2016 specifies principles, procedures and requirements for environmental technology verification (ETV), and was developed and published by the *International Organization for Standardization (ISO)*. The objective of ETV is to provide credible, reliable and independent verification of the performance of environmental technologies. An environmental technology is a technology that either results in an environmental added value or measures parameters that indicate an environmental impact. Such technologies have an increasingly important role in addressing environmental challenges and achieving sustainable development.

For more information on the Stormceptor® EF and EFO OGS please contact:

Imbrium Systems, Inc.
407 Fairview Drive
Whitby, ON
L1N 3A9, Canada
Tel: 416-960-9900
info@imbriumsystems.com

For more information on ISO 14034:2016 / ETV please contact:

GLOBE Performance Solutions
World Trade Centre
404 – 999 Canada Place
Vancouver, BC
V6C 3E2 Canada
Tel: 604-695-5018 / Toll Free: 1-855-695-5018
etv@globeperformance.com

Limitation of verification - Registration: GPS-ETV_VR2023-11-15_Imbrium-SC

GLOBE Performance Solutions and the Verification Expert provide the verification services solely on the basis of the information supplied by the applicant or vendor and assume no liability thereafter. The responsibility for the information supplied remains solely with the applicant or vendor and the liability for the purchase, installation, and operation (whether consequential or otherwise) is not transferred to any other party as a result of the verification.

Stormceptor® EF Sizing Report

Imbrium® Systems

ESTIMATED NET ANNUAL SEDIMENT (TSS) LOAD REDUCTION

02/23/2024

Province:	Ontario
City:	Ottawa
Nearest Rainfall Station:	OTTAWA CDA RCS
Climate Station Id:	6105978
Years of Rainfall Data:	20

Project Name:	AMRC
Project Number:	CA0009956.0165
Designer Name:	Fiona Allen
Designer Company:	WSP
Designer Email:	Fiona.Allen@WSP.com
Designer Phone:	289-982-4299
EOR Name:	
EOR Company:	
EOR Email:	
EOR Phone:	

Site Name:	AMRC to Chamber
------------	-----------------

Drainage Area (ha):	0.30
---------------------	------

% Imperviousness:	68.00
-------------------	-------

Runoff Coefficient 'c': 0.70

Particle Size Distribution:	CA ETV
-----------------------------	--------

Target TSS Removal (%):	60.0
-------------------------	------

Required Water Quality Runoff Volume Capture (%):	90.00
Estimated Water Quality Flow Rate (L/s):	6.86
Oil / Fuel Spill Risk Site?	Yes
Upstream Flow Control?	No
Peak Conveyance (maximum) Flow Rate (L/s):	
Influent TSS Concentration (mg/L):	200
Estimated Average Annual Sediment Load (kg/yr):	172
Estimated Average Annual Sediment Volume (L/yr):	140

Net Annual Sediment (TSS) Load Reduction Sizing Summary	
Stormceptor Model	TSS Removal Provided (%)
EFO4	62
EFO6	67
EFO8	69
EFO10	70
EFO12	70

Recommended Stormceptor EFO Model: EFO4

Estimated Net Annual Sediment (TSS) Load Reduction (%): 62

Water Quality Runoff Volume Capture (%): > 90



Stormceptor® EF Sizing Report

THIRD-PARTY TESTING AND VERIFICATION

► **Stormceptor® EF and Stormceptor® EFO** are the latest evolutions in the Stormceptor® oil-grit separator (OGS) technology series, and are designed to remove a wide variety of pollutants from stormwater and snowmelt runoff. These technologies have been third-party tested in accordance with the Canadian ETV **Procedure for Laboratory Testing of Oil-Grit Separators** and performance has been third-party verified in accordance with the **ISO 14034 Environmental Technology Verification (ETV)** protocol.

PERFORMANCE

► **Stormceptor® EF and EFO** remove stormwater pollutants through gravity separation and floatation, and feature a patent-pending design that generates positive removal of total suspended solids (TSS) throughout each storm event, including high-intensity storms. Captured pollutants include sediment, free oils, and sediment-bound pollutants such as nutrients, heavy metals, and petroleum hydrocarbons. Stormceptor is sized to remove a high level of TSS from the frequent rainfall events that contribute the vast majority of annual runoff volume and pollutant load. The technology incorporates an internal bypass to convey excessive stormwater flows from high-intensity storms through the device without resuspension and washout (scour) of previously captured pollutants. Proper routine maintenance ensures high pollutant removal performance and protection of downstream waterways.

PARTICLE SIZE DISTRIBUTION (PSD)

► The **Canadian ETV PSD** shown in the table below was used, or in part, for this sizing. This is the identical PSD that is referenced in the Canadian ETV **Procedure for Laboratory Testing of Oil-Grit Separators** for both sediment removal testing and scour testing. The Canadian ETV PSD contains a wide range of particle sizes in the sand and silt fractions, and is considered reasonably representative of the particle size fractions found in typical urban stormwater runoff.

Particle Size (µm)	Percent Less Than	Particle Size Fraction (µm)	Percent
1000	100	500-1000	5
500	95	250-500	5
250	90	150-250	15
150	75	100-150	15
100	60	75-100	10
75	50	50-75	5
50	45	20-50	10
20	35	8-20	15
8	20	5-8	10
5	10	2-5	5
2	5	<2	5

Stormceptor® EF Sizing Report

Rainfall Intensity (mm / hr)	Percent Rainfall Volume (%)	Cumulative Rainfall Volume (%)	Flow Rate (L/s)	Flow Rate (L/min)	Surface Loading Rate (L/min/m ²)	Removal Efficiency (%)	Incremental Removal (%)	Cumulative Removal (%)
0.50	8.6	8.6	0.30	18.0	15.0	70	6.1	6.1
1.00	20.3	29.0	0.59	35.0	30.0	70	14.3	20.4
2.00	16.2	45.2	1.18	71.0	59.0	67	10.9	31.3
3.00	12.0	57.2	1.77	106.0	89.0	64	7.7	39.0
4.00	8.4	65.6	2.36	142.0	118.0	62	5.2	44.2
5.00	5.9	71.6	2.95	177.0	148.0	59	3.5	47.7
6.00	4.6	76.2	3.54	213.0	177.0	57	2.6	50.3
7.00	3.1	79.3	4.13	248.0	207.0	54	1.7	51.9
8.00	2.7	82.0	4.72	283.0	236.0	53	1.5	53.4
9.00	3.3	85.3	5.31	319.0	266.0	52	1.7	55.1
10.00	2.3	87.6	5.90	354.0	295.0	51	1.2	56.3
11.00	1.6	89.2	6.50	390.0	325.0	50	0.8	57.1
12.00	1.3	90.5	7.09	425.0	354.0	50	0.7	57.8
13.00	1.7	92.2	7.68	461.0	384.0	49	0.8	58.6
14.00	1.2	93.5	8.27	496.0	413.0	48	0.6	59.2
15.00	1.2	94.6	8.86	531.0	443.0	47	0.5	59.7
16.00	0.7	95.3	9.45	567.0	472.0	46	0.3	60.0
17.00	0.7	96.1	10.04	602.0	502.0	45	0.3	60.4
18.00	0.4	96.5	10.63	638.0	531.0	44	0.2	60.5
19.00	0.4	96.9	11.22	673.0	561.0	43	0.2	60.7
20.00	0.2	97.1	11.81	709.0	590.0	42	0.1	60.8
21.00	0.5	97.5	12.40	744.0	620.0	42	0.2	61.0
22.00	0.2	97.8	12.99	779.0	650.0	42	0.1	61.1
23.00	1.0	98.8	13.58	815.0	679.0	42	0.4	61.5
24.00	0.3	99.1	14.17	850.0	709.0	42	0.1	61.6
25.00	0.0	99.1	14.76	886.0	738.0	41	0.0	61.6
30.00	0.9	100.0	17.71	1063.0	886.0	41	0.4	62.0
35.00	0.0	100.0	20.67	1240.0	1033.0	40	0.0	62.0
40.00	0.0	100.0	23.62	1417.0	1181.0	37	0.0	62.0
45.00	0.0	100.0	26.57	1594.0	1329.0	35	0.0	62.0
Estimated Net Annual Sediment (TSS) Load Reduction =								62 %

Climate Station ID: 6105978 Years of Rainfall Data: 20

Stormceptor® EF Sizing Report

RAINFALL DATA FROM OTTAWA CDA RCS RAINFALL STATION

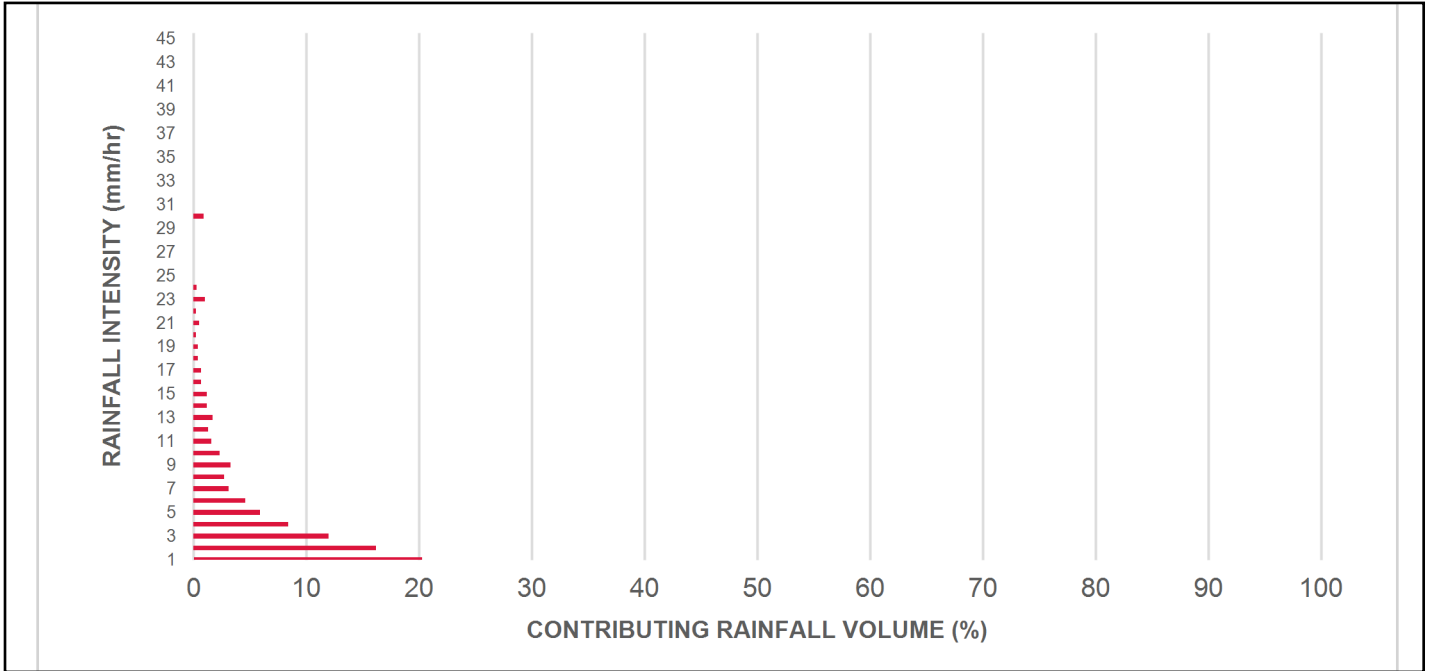

INCREMENTAL AND CUMULATIVE TSS REMOVAL FOR THE RECOMMENDED STORMCEPTOR® MODEL

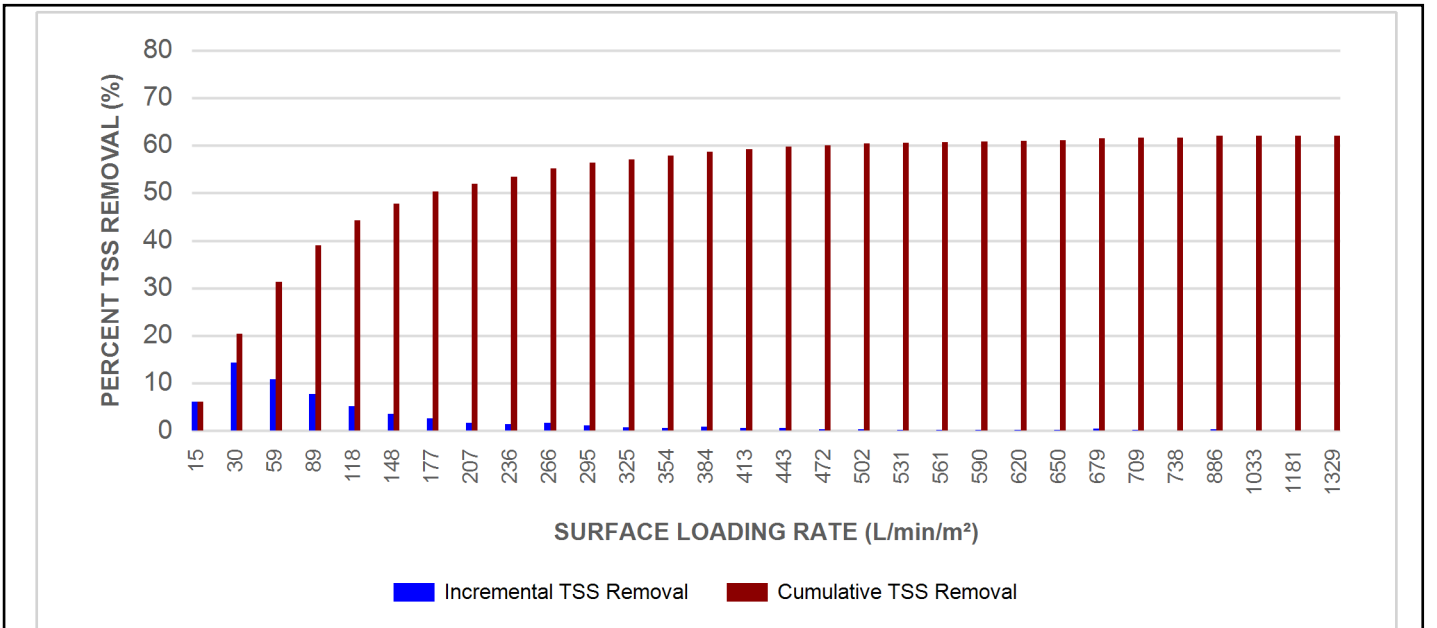

Stormceptor® EF Sizing Report

Maximum Pipe Diameter / Peak Conveyance

Stormceptor EF / EFO	Model Diameter		Min Angle Inlet / Outlet Pipes	Max Inlet Pipe Diameter		Max Outlet Pipe Diameter		Peak Conveyance Flow Rate	
	(m)	(ft)		(mm)	(in)	(mm)	(in)	(L/s)	(cfs)
EF4 / EFO4	1.2	4	90	609	24	609	24	425	15
EF6 / EFO6	1.8	6	90	914	36	914	36	990	35
EF8 / EFO8	2.4	8	90	1219	48	1219	48	1700	60
EF10 / EFO10	3.0	10	90	1828	72	1828	72	2830	100
EF12 / EFO12	3.6	12	90	1828	72	1828	72	2830	100

SCOUR PREVENTION AND ONLINE CONFIGURATION

► Stormceptor® EF and EFO feature an internal bypass and superior scour prevention technology that have been demonstrated in third-party testing according to the scour testing provisions of the Canadian ETV **Procedure for Laboratory Testing of Oil-Grit Separators**, and the exceptional scour test performance has been third-party verified in accordance with the ISO 14034 ETV protocol. As a result, Stormceptor EF and EFO are approved for online installation, eliminating the need for costly additional bypass structures, piping, and installation expense.

DESIGN FLEXIBILITY

► Stormceptor® EF and EFO offers design flexibility in one simplified platform, accepting stormwater flow from a single inlet pipe or multiple inlet pipes, and/or surface runoff through an inlet grate. The device can also serve as a junction structure, accommodate a 90-degree inlet-to-outlet bend angle, and can be modified to ensure performance in submerged conditions.

OIL CAPTURE AND RETENTION

► While Stormceptor® EF will capture and retain oil from dry weather spills and low intensity runoff, Stormceptor® EFO has demonstrated superior oil capture and greater than 99% oil retention in third-party testing according to the light liquid re-entrainment testing provisions of the Canadian ETV **Procedure for Laboratory Testing of Oil-Grit Separators**. Stormceptor EFO is recommended for sites where oil capture and retention is a requirement.

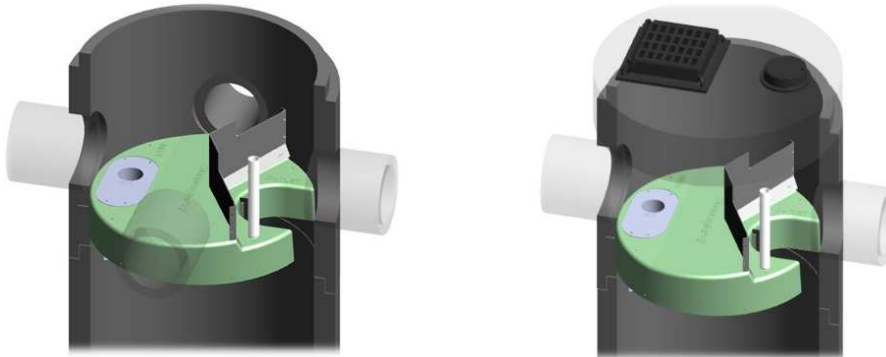

Stormceptor® EF Sizing Report

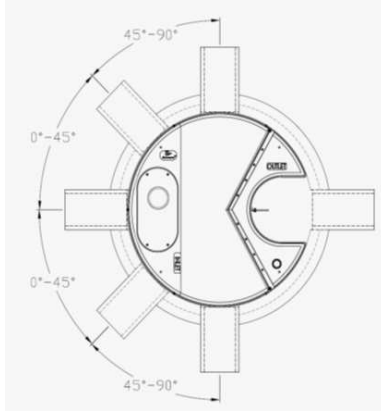

INLET-TO-OUTLET DROP

Elevation differential between inlet and outlet pipe inverts is dictated by the angle at which the inlet pipe(s) enters the unit.

0° - 45° : The inlet pipe is 1-inch (25mm) higher than the outlet pipe.

45° - 90° : The inlet pipe is 2-inches (50mm) higher than the outlet pipe.

HEAD LOSS

The head loss through Stormceptor EF is similar to that of a 60-degree bend structure. The applicable K value for calculating minor losses through the unit is 1.1. For submerged conditions the applicable K value is 3.0.

Pollutant Capacity

Stormceptor EF / EFO	Model Diameter		Depth (Outlet Pipe Invert to Sump Floor)		Oil Volume		Recommended Sediment Maintenance Depth *		Maximum Sediment Volume *		Maximum Sediment Mass **	
	(m)	(ft)	(m)	(ft)	(L)	(Gal)	(mm)	(in)	(L)	(ft³)	(kg)	(lb)
EF4 / EFO4	1.2	4	1.52	5.0	265	70	203	8	1190	42	1904	5250
EF6 / EFO6	1.8	6	1.93	6.3	610	160	305	12	3470	123	5552	15375
EF8 / EFO8	2.4	8	2.59	8.5	1070	280	610	24	8780	310	14048	38750
EF10 / EFO10	3.0	10	3.25	10.7	1670	440	610	24	17790	628	28464	78500
EF12 / EFO12	3.6	12	3.89	12.8	2475	655	610	24	31220	1103	49952	137875

*Increased sump depth may be added to increase sediment storage capacity

** Average density of wet packed sediment in sump = 1.6 kg/L (100 lb/ft³)

Feature	Benefit	Feature Appeals To
Patent-pending enhanced flow treatment and scour prevention technology	Superior, verified third-party performance	Regulator, Specifying & Design Engineer
Third-party verified light liquid capture and retention for EFO version	Proven performance for fuel/oil hotspot locations	Regulator, Specifying & Design Engineer, Site Owner
Functions as bend, junction or inlet structure	Design flexibility	Specifying & Design Engineer
Minimal drop between inlet and outlet	Site installation ease	Contractor
Large diameter outlet riser for inspection and maintenance	Easy maintenance access from grade	Maintenance Contractor & Site Owner

STANDARD STORMCEPTOR EF/EFO DRAWINGS

For standard details, please visit <http://www.imbriumsystems.com/stormwater-treatment-solutions/stormceptor-ef>

STANDARD STORMCEPTOR EF/EFO SPECIFICATION

For specifications, please visit <http://www.imbriumsystems.com/stormwater-treatment-solutions/stormceptor-ef>

Stormceptor® EF Sizing Report

**Table of TSS Removal vs Surface Loading Rate Based on Third-Party Test Results
Stormceptor® EFO**

SLR (L/min/m ²)	TSS % REMOVAL	SLR (L/min/m ²)	TSS % REMOVAL	SLR (L/min/m ²)	TSS % REMOVAL	SLR (L/min/m ²)	TSS % REMOVAL
1	70	660	42	1320	35	1980	24
30	70	690	42	1350	35	2010	24
60	67	720	41	1380	34	2040	23
90	63	750	41	1410	34	2070	23
120	61	780	41	1440	33	2100	23
150	58	810	41	1470	32	2130	22
180	56	840	41	1500	32	2160	22
210	54	870	41	1530	31	2190	22
240	53	900	41	1560	31	2220	21
270	52	930	40	1590	30	2250	21
300	51	960	40	1620	29	2280	21
330	50	990	40	1650	29	2310	21
360	49	1020	40	1680	28	2340	20
390	48	1050	39	1710	28	2370	20
420	47	1080	39	1740	27	2400	20
450	47	1110	38	1770	27	2430	20
480	46	1140	38	1800	26	2460	19
510	45	1170	37	1830	26	2490	19
540	44	1200	37	1860	26	2520	19
570	43	1230	37	1890	25	2550	19
600	42	1260	36	1920	25	2580	18
630	42	1290	36	1950	24	2600	26

STANDARD PERFORMANCE SPECIFICATION FOR “OIL GRIT SEPARATOR” (OGS) STORMWATER QUALITY TREATMENT DEVICE

PART 1 – GENERAL

1.1 WORK INCLUDED

This section specifies requirements for selecting, sizing, and designing an underground Oil Grit Separator (OGS) device for stormwater quality treatment, with third-party testing results and a Statement of Verification in accordance with ISO 14034 Environmental Management – Environmental Technology Verification (ETV).

1.2 REFERENCE STANDARDS & PROCEDURES

ISO 14034:2016 Environmental management – Environmental technology verification (ETV)

Canadian Environmental Technology Verification (ETV) Program’s **Procedure for Laboratory Testing of Oil-Grit Separators**

1.3 SUBMITTALS

1.3.1 All submittals, including sizing reports & shop drawings, shall be submitted upon request with each order to the contractor then forwarded to the Engineer of Record for review and acceptance. Shop drawings shall detail all OGS components, elevations, and sequence of construction.

1.3.2 Alternative devices shall have features identical to or greater than the specified device, including: treatment chamber diameter, treatment chamber wet volume, sediment storage volume, and oil storage volume.

1.3.3 Unless directed otherwise by the Engineer of Record, OGS stormwater quality treatment product substitutions or alternatives submitted within ten days prior to project bid shall not be accepted. All alternatives or substitutions submitted shall be signed and sealed by a local registered Professional Engineer, based on the exact same criteria detailed in Section 3, in entirety, subject to review and approval by the Engineer of Record.

PART 2 – PRODUCTS

2.1 OGS POLLUTANT STORAGE

The OGS device shall include a sump for sediment storage, and a protected volume for the capture and storage of petroleum hydrocarbons and buoyant gross pollutants. The minimum sediment & petroleum hydrocarbon storage capacity shall be as follows:

2.1.1	4 ft (1219 mm) Diameter OGS Units:	1.19 m ³ sediment / 265 L oil
	6 ft (1829 mm) Diameter OGS Units:	3.48 m ³ sediment / 609 L oil
	8 ft (2438 mm) Diameter OGS Units:	8.78 m ³ sediment / 1,071 L oil
	10 ft (3048 mm) Diameter OGS Units:	17.78 m ³ sediment / 1,673 L oil
	12 ft (3657 mm) Diameter OGS Units:	31.23 m ³ sediment / 2,476 L oil

PART 3 – PERFORMANCE & DESIGN

3.1 GENERAL

The OGS stormwater quality treatment device shall be verified in accordance with ISO 14034:2016 Environmental management – Environmental technology verification (ETV). The OGS stormwater quality treatment device shall

Stormceptor® EF Sizing Report

remove oil, sediment and gross pollutants from stormwater runoff during frequent wet weather events, and retain these pollutants during less frequent high flow wet weather events below the insert within the OGS for later removal during maintenance. The Manufacturer shall have at least ten (10) years of local experience, history and success in engineering design, manufacturing and production and supply of OGS stormwater quality treatment device systems, acceptable to the Engineer of Record.

3.2 SIZING METHODOLOGY

The OGS device shall be engineered, designed and sized to provide stormwater quality treatment based on treating a minimum of 90 percent of the average annual runoff volume and a minimum removal of an annual average 60% of the sediment (TSS) load based on the Particle Size Distribution (PSD) specified in the sizing report for the specified device. Sizing of the OGS shall be determined by use of a minimum ten (10) years of local historical rainfall data provided by Environment Canada. Sizing shall also be determined by use of the sediment removal performance data derived from the ISO 14034 ETV third-party verified laboratory testing data from testing conducted in accordance with the Canadian ETV protocol Procedure for Laboratory Testing of Oil-Grit Separators, as follows:

3.2.1 Sediment removal efficiency for a given surface loading rate and its associated flow rate shall be based on sediment removal efficiency demonstrated at the seven (7) tested surface loading rates specified in the protocol, ranging 40 L/min/m² to 1400 L/min/m², and as stated in the ISO 14034 ETV Verification Statement for the OGS device.

3.2.2 Sediment removal efficiency for surface loading rates between 40 L/min/m² and 1400 L/min/m² shall be based on linear interpolation of data between consecutive tested surface loading rates.

3.2.3 Sediment removal efficiency for surface loading rates less than the lowest tested surface loading rate of 40 L/min/m² shall be assumed to be identical to the sediment removal efficiency at 40 L/min/m². No extrapolation shall be allowed that results in a sediment removal efficiency that is greater than that demonstrated at 40 L/min/m².

3.2.4 Sediment removal efficiency for surface loading rates greater than the highest tested surface loading rate of 1400 L/min/m² shall assume zero sediment removal for the portion of flow that exceeds 1400 L/min/m², and shall be calculated using a simple proportioning formula, with 1400 L/min/m² in the numerator and the higher surface loading rate in the denominator, and multiplying the resulting fraction times the sediment removal efficiency at 1400 L/min/m².

The OGS device shall also have sufficient annual sediment storage capacity as specified and calculated in Section 2.1.

3.3 CANADIAN ETV or ISO 14034 ETV VERIFICATION OF SCOUR TESTING

The OGS device shall have Canadian ETV or ISO 14034 ETV Verification of third-party scour testing conducted in accordance with the Canadian ETV Program's **Procedure for Laboratory Testing of Oil-Grit Separators**.

3.3.1 To be acceptable for on-line installation, the OGS device must demonstrate an average scour test effluent concentration less than 10 mg/L at each surface loading rate tested, up to and including 2600 L/min/m².

3.4 LIGHT LIQUID RE-ENTRAINMENT SIMULATION TESTING

The OGS device shall have Canadian ETV or ISO 14034 ETV Verification of completed third-party Light Liquid Re-entrainment Simulation Testing in accordance with the Canadian ETV **Program's Procedure for Laboratory Testing of Oil-Grit Separators**, with results reported within the Canadian ETV or ISO 14034 ETV verification. This re-entrainment testing is conducted with the device pre-loaded with low density polyethylene (LDPE) plastic beads as a surrogate for light liquids such as oil and fuel. Testing is conducted on the same OGS unit tested for sediment removal to

Stormceptor® EF Sizing Report

assess whether light liquids captured after a spill are effectively retained at high flow rates.

3.4.1 For an OGS device to be an acceptable stormwater treatment device on a site where vehicular traffic occurs and the potential for an oil or fuel spill exists, the OGS device must have reported verified performance results of greater than 99% cumulative retention of LDPE plastic beads for the five specified surface loading rates (ranging 200 L/min/m² to 2600 L/min/m²) in accordance with the Light Liquid Re-entrainment Simulation Testing within the Canadian ETV Program's **Procedure for Laboratory Testing of Oil-Grit Separators**. However, an OGS device shall not be allowed if the Light Liquid Re-entrainment Simulation Testing was performed with screening components within the OGS device that are effective at retaining the LDPE plastic beads, but would not be expected to retain light liquids such as oil and fuel.

Stormceptor® EF Sizing Report

Imbrium® Systems

ESTIMATED NET ANNUAL SEDIMENT (TSS) LOAD REDUCTION

02/23/2024

Province:	Ontario
City:	Ottawa
Nearest Rainfall Station:	OTTAWA CDA RCS
Climate Station Id:	6105978
Years of Rainfall Data:	20

Project Name:	AMRC
Project Number:	CA0009956.0165
Designer Name:	Fiona Allen
Designer Company:	WSP
Designer Email:	Fiona.Allen@WSP.com
Designer Phone:	289-982-4299
EOR Name:	
EOR Company:	
EOR Email:	
EOR Phone:	

Site Name:	AMRC to Pond
Drainage Area (ha):	0.82
% Imperviousness:	73.00
Runoff Coefficient 'c': 0.73	

Particle Size Distribution:	CA ETV
Target TSS Removal (%):	60.0

Required Water Quality Runoff Volume Capture (%):	90.00
Estimated Water Quality Flow Rate (L/s):	19.53
Oil / Fuel Spill Risk Site?	Yes
Upstream Flow Control?	No
Peak Conveyance (maximum) Flow Rate (L/s):	
Influent TSS Concentration (mg/L):	200
Estimated Average Annual Sediment Load (kg/yr):	489
Estimated Average Annual Sediment Volume (L/yr):	397

Net Annual Sediment (TSS) Load Reduction Sizing Summary	
Stormceptor Model	TSS Removal Provided (%)
EFO4	53
EFO6	60
EFO8	64
EFO10	67
EFO12	68

Recommended Stormceptor EFO Model: EFO6
Estimated Net Annual Sediment (TSS) Load Reduction (%): 60
Water Quality Runoff Volume Capture (%): > 90



THIRD-PARTY TESTING AND VERIFICATION

► **Stormceptor® EF and Stormceptor® EFO** are the latest evolutions in the Stormceptor® oil-grit separator (OGS) technology series, and are designed to remove a wide variety of pollutants from stormwater and snowmelt runoff. These technologies have been third-party tested in accordance with the Canadian ETV **Procedure for Laboratory Testing of Oil-Grit Separators** and performance has been third-party verified in accordance with the **ISO 14034 Environmental Technology Verification (ETV)** protocol.

PERFORMANCE

► **Stormceptor® EF and EFO** remove stormwater pollutants through gravity separation and floatation, and feature a patent-pending design that generates positive removal of total suspended solids (TSS) throughout each storm event, including high-intensity storms. Captured pollutants include sediment, free oils, and sediment-bound pollutants such as nutrients, heavy metals, and petroleum hydrocarbons. Stormceptor is sized to remove a high level of TSS from the frequent rainfall events that contribute the vast majority of annual runoff volume and pollutant load. The technology incorporates an internal bypass to convey excessive stormwater flows from high-intensity storms through the device without resuspension and washout (scour) of previously captured pollutants. Proper routine maintenance ensures high pollutant removal performance and protection of downstream waterways.

PARTICLE SIZE DISTRIBUTION (PSD)

► The **Canadian ETV PSD** shown in the table below was used, or in part, for this sizing. This is the identical PSD that is referenced in the Canadian ETV **Procedure for Laboratory Testing of Oil-Grit Separators** for both sediment removal testing and scour testing. The Canadian ETV PSD contains a wide range of particle sizes in the sand and silt fractions, and is considered reasonably representative of the particle size fractions found in typical urban stormwater runoff.

Particle Size (µm)	Percent Less Than	Particle Size Fraction (µm)	Percent
1000	100	500-1000	5
500	95	250-500	5
250	90	150-250	15
150	75	100-150	15
100	60	75-100	10
75	50	50-75	5
50	45	20-50	10
20	35	8-20	15
8	20	5-8	10
5	10	2-5	5
2	5	<2	5

Stormceptor® EF Sizing Report

Rainfall Intensity (mm / hr)	Percent Rainfall Volume (%)	Cumulative Rainfall Volume (%)	Flow Rate (L/s)	Flow Rate (L/min)	Surface Loading Rate (L/min/m ²)	Removal Efficiency (%)	Incremental Removal (%)	Cumulative Removal (%)
0.50	8.6	8.6	0.84	50.0	19.0	70	6.1	6.1
1.00	20.3	29.0	1.68	101.0	38.0	70	14.3	20.4
2.00	16.2	45.2	3.36	202.0	77.0	66	10.6	31.0
3.00	12.0	57.2	5.05	303.0	115.0	62	7.4	38.4
4.00	8.4	65.6	6.73	404.0	154.0	58	4.9	43.3
5.00	5.9	71.6	8.41	505.0	192.0	55	3.3	46.6
6.00	4.6	76.2	10.09	606.0	230.0	53	2.5	49.0
7.00	3.1	79.3	11.78	707.0	269.0	52	1.6	50.6
8.00	2.7	82.0	13.46	808.0	307.0	51	1.4	52.0
9.00	3.3	85.3	15.14	908.0	345.0	50	1.7	53.7
10.00	2.3	87.6	16.82	1009.0	384.0	49	1.1	54.8
11.00	1.6	89.2	18.51	1110.0	422.0	47	0.7	55.6
12.00	1.3	90.5	20.19	1211.0	461.0	46	0.6	56.2
13.00	1.7	92.2	21.87	1312.0	499.0	45	0.8	56.9
14.00	1.2	93.5	23.55	1413.0	537.0	44	0.5	57.5
15.00	1.2	94.6	25.24	1514.0	576.0	43	0.5	58.0
16.00	0.7	95.3	26.92	1615.0	614.0	42	0.3	58.3
17.00	0.7	96.1	28.60	1716.0	652.0	42	0.3	58.6
18.00	0.4	96.5	30.28	1817.0	691.0	42	0.2	58.7
19.00	0.4	96.9	31.96	1918.0	729.0	41	0.2	58.9
20.00	0.2	97.1	33.65	2019.0	768.0	41	0.1	59.0
21.00	0.5	97.5	35.33	2120.0	806.0	41	0.2	59.2
22.00	0.2	97.8	37.01	2221.0	844.0	41	0.1	59.3
23.00	1.0	98.8	38.69	2322.0	883.0	41	0.4	59.7
24.00	0.3	99.1	40.38	2423.0	921.0	40	0.1	59.8
25.00	0.0	99.1	42.06	2524.0	960.0	40	0.0	59.8
30.00	0.9	100.0	50.47	3028.0	1151.0	38	0.4	60.2
35.00	0.0	100.0	58.88	3533.0	1343.0	35	0.0	60.2
40.00	0.0	100.0	67.29	4038.0	1535.0	31	0.0	60.2
45.00	0.0	100.0	75.71	4542.0	1727.0	28	0.0	60.2
Estimated Net Annual Sediment (TSS) Load Reduction =								60 %

Climate Station ID: 6105978 Years of Rainfall Data: 20

Stormceptor® EF Sizing Report

RAINFALL DATA FROM OTTAWA CDA RCS RAINFALL STATION

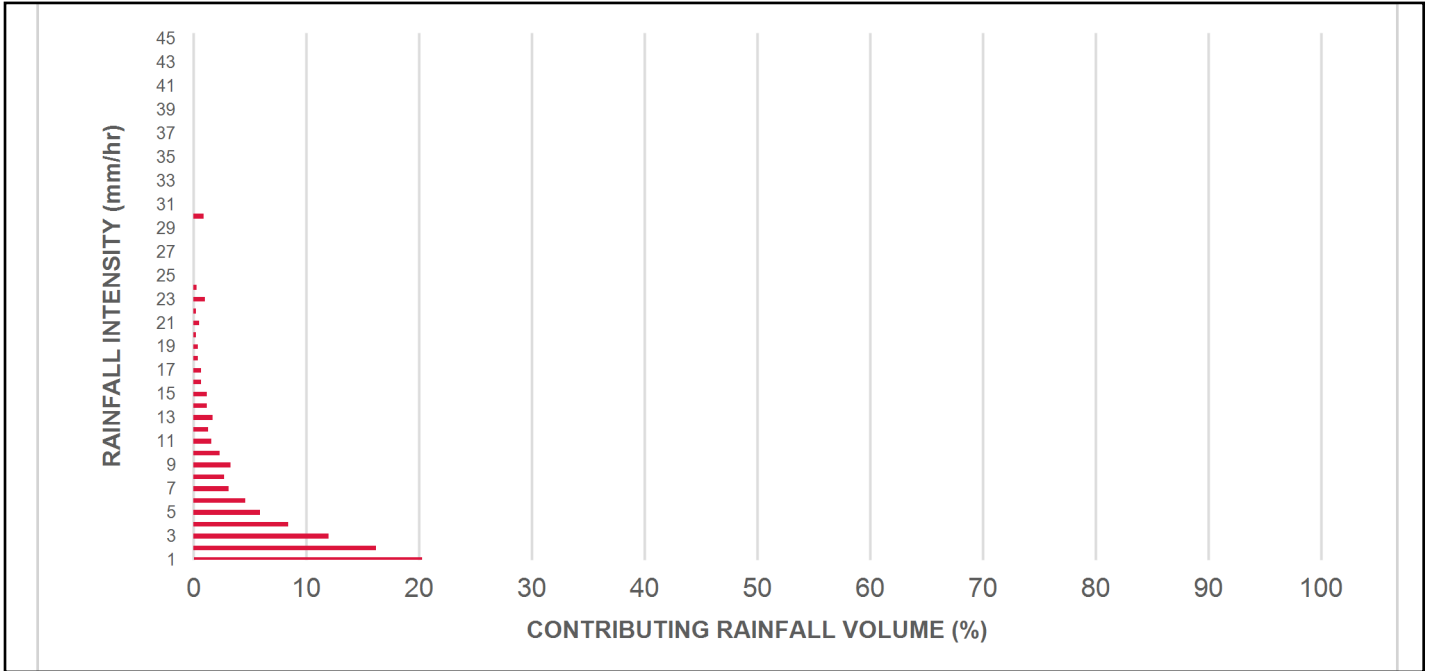

INCREMENTAL AND CUMULATIVE TSS REMOVAL FOR THE RECOMMENDED STORMCEPTOR® MODEL

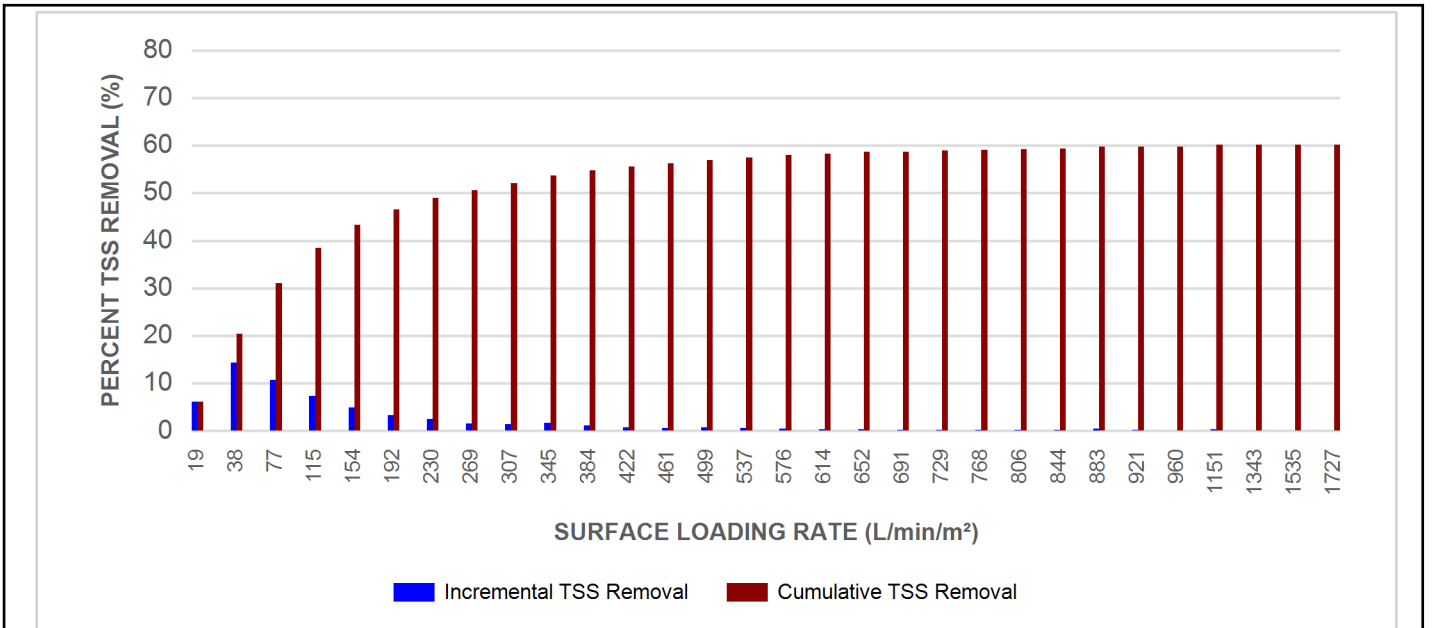

Stormceptor® EF Sizing Report

Maximum Pipe Diameter / Peak Conveyance

Stormceptor EF / EFO	Model Diameter		Min Angle Inlet / Outlet Pipes	Max Inlet Pipe Diameter		Max Outlet Pipe Diameter		Peak Conveyance Flow Rate	
	(m)	(ft)		(mm)	(in)	(mm)	(in)	(L/s)	(cfs)
EF4 / EFO4	1.2	4	90	609	24	609	24	425	15
EF6 / EFO6	1.8	6	90	914	36	914	36	990	35
EF8 / EFO8	2.4	8	90	1219	48	1219	48	1700	60
EF10 / EFO10	3.0	10	90	1828	72	1828	72	2830	100
EF12 / EFO12	3.6	12	90	1828	72	1828	72	2830	100

SCOUR PREVENTION AND ONLINE CONFIGURATION

► Stormceptor® EF and EFO feature an internal bypass and superior scour prevention technology that have been demonstrated in third-party testing according to the scour testing provisions of the Canadian ETV **Procedure for Laboratory Testing of Oil-Grit Separators**, and the exceptional scour test performance has been third-party verified in accordance with the ISO 14034 ETV protocol. As a result, Stormceptor EF and EFO are approved for online installation, eliminating the need for costly additional bypass structures, piping, and installation expense.

DESIGN FLEXIBILITY

► Stormceptor® EF and EFO offers design flexibility in one simplified platform, accepting stormwater flow from a single inlet pipe or multiple inlet pipes, and/or surface runoff through an inlet grate. The device can also serve as a junction structure, accommodate a 90-degree inlet-to-outlet bend angle, and can be modified to ensure performance in submerged conditions.

OIL CAPTURE AND RETENTION

► While Stormceptor® EF will capture and retain oil from dry weather spills and low intensity runoff, Stormceptor® EFO has demonstrated superior oil capture and greater than 99% oil retention in third-party testing according to the light liquid re-entrainment testing provisions of the Canadian ETV **Procedure for Laboratory Testing of Oil-Grit Separators**. Stormceptor EFO is recommended for sites where oil capture and retention is a requirement.

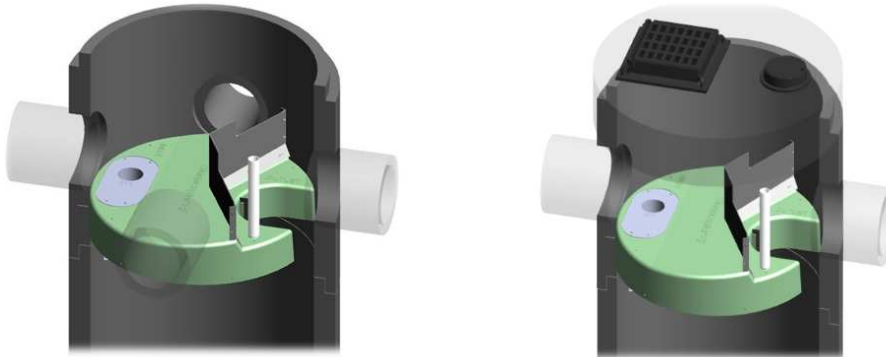

Stormceptor® EF Sizing Report

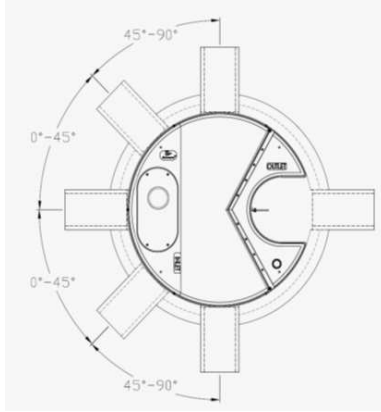

INLET-TO-OUTLET DROP

Elevation differential between inlet and outlet pipe inverts is dictated by the angle at which the inlet pipe(s) enters the unit.

0° - 45° : The inlet pipe is 1-inch (25mm) higher than the outlet pipe.

45° - 90° : The inlet pipe is 2-inches (50mm) higher than the outlet pipe.

HEAD LOSS

The head loss through Stormceptor EF is similar to that of a 60-degree bend structure. The applicable K value for calculating minor losses through the unit is 1.1. For submerged conditions the applicable K value is 3.0.

Pollutant Capacity

Stormceptor EF / EFO	Model Diameter		Depth (Outlet Pipe Invert to Sump Floor)		Oil Volume		Recommended Sediment Maintenance Depth *		Maximum Sediment Volume *		Maximum Sediment Mass **	
	(m)	(ft)	(m)	(ft)	(L)	(Gal)	(mm)	(in)	(L)	(ft³)	(kg)	(lb)
EF4 / EFO4	1.2	4	1.52	5.0	265	70	203	8	1190	42	1904	5250
EF6 / EFO6	1.8	6	1.93	6.3	610	160	305	12	3470	123	5552	15375
EF8 / EFO8	2.4	8	2.59	8.5	1070	280	610	24	8780	310	14048	38750
EF10 / EFO10	3.0	10	3.25	10.7	1670	440	610	24	17790	628	28464	78500
EF12 / EFO12	3.6	12	3.89	12.8	2475	655	610	24	31220	1103	49952	137875

*Increased sump depth may be added to increase sediment storage capacity

** Average density of wet packed sediment in sump = 1.6 kg/L (100 lb/ft³)

Feature	Benefit	Feature Appeals To
Patent-pending enhanced flow treatment and scour prevention technology	Superior, verified third-party performance	Regulator, Specifying & Design Engineer
Third-party verified light liquid capture and retention for EFO version	Proven performance for fuel/oil hotspot locations	Regulator, Specifying & Design Engineer, Site Owner
Functions as bend, junction or inlet structure	Design flexibility	Specifying & Design Engineer
Minimal drop between inlet and outlet	Site installation ease	Contractor
Large diameter outlet riser for inspection and maintenance	Easy maintenance access from grade	Maintenance Contractor & Site Owner

STANDARD STORMCEPTOR EF/EFO DRAWINGS

For standard details, please visit <http://www.imbriumsystems.com/stormwater-treatment-solutions/stormceptor-ef>

STANDARD STORMCEPTOR EF/EFO SPECIFICATION

For specifications, please visit <http://www.imbriumsystems.com/stormwater-treatment-solutions/stormceptor-ef>

Stormceptor® EF Sizing Report

**Table of TSS Removal vs Surface Loading Rate Based on Third-Party Test Results
Stormceptor® EFO**

SLR (L/min/m ²)	TSS % REMOVAL	SLR (L/min/m ²)	TSS % REMOVAL	SLR (L/min/m ²)	TSS % REMOVAL	SLR (L/min/m ²)	TSS % REMOVAL
1	70	660	42	1320	35	1980	24
30	70	690	42	1350	35	2010	24
60	67	720	41	1380	34	2040	23
90	63	750	41	1410	34	2070	23
120	61	780	41	1440	33	2100	23
150	58	810	41	1470	32	2130	22
180	56	840	41	1500	32	2160	22
210	54	870	41	1530	31	2190	22
240	53	900	41	1560	31	2220	21
270	52	930	40	1590	30	2250	21
300	51	960	40	1620	29	2280	21
330	50	990	40	1650	29	2310	21
360	49	1020	40	1680	28	2340	20
390	48	1050	39	1710	28	2370	20
420	47	1080	39	1740	27	2400	20
450	47	1110	38	1770	27	2430	20
480	46	1140	38	1800	26	2460	19
510	45	1170	37	1830	26	2490	19
540	44	1200	37	1860	26	2520	19
570	43	1230	37	1890	25	2550	19
600	42	1260	36	1920	25	2580	18
630	42	1290	36	1950	24	2600	26

STANDARD PERFORMANCE SPECIFICATION FOR “OIL GRIT SEPARATOR” (OGS) STORMWATER QUALITY TREATMENT DEVICE

PART 1 – GENERAL

1.1 WORK INCLUDED

This section specifies requirements for selecting, sizing, and designing an underground Oil Grit Separator (OGS) device for stormwater quality treatment, with third-party testing results and a Statement of Verification in accordance with ISO 14034 Environmental Management – Environmental Technology Verification (ETV).

1.2 REFERENCE STANDARDS & PROCEDURES

ISO 14034:2016 Environmental management – Environmental technology verification (ETV)

Canadian Environmental Technology Verification (ETV) Program’s **Procedure for Laboratory Testing of Oil-Grit Separators**

1.3 SUBMITTALS

1.3.1 All submittals, including sizing reports & shop drawings, shall be submitted upon request with each order to the contractor then forwarded to the Engineer of Record for review and acceptance. Shop drawings shall detail all OGS components, elevations, and sequence of construction.

1.3.2 Alternative devices shall have features identical to or greater than the specified device, including: treatment chamber diameter, treatment chamber wet volume, sediment storage volume, and oil storage volume.

1.3.3 Unless directed otherwise by the Engineer of Record, OGS stormwater quality treatment product substitutions or alternatives submitted within ten days prior to project bid shall not be accepted. All alternatives or substitutions submitted shall be signed and sealed by a local registered Professional Engineer, based on the exact same criteria detailed in Section 3, in entirety, subject to review and approval by the Engineer of Record.

PART 2 – PRODUCTS

2.1 OGS POLLUTANT STORAGE

The OGS device shall include a sump for sediment storage, and a protected volume for the capture and storage of petroleum hydrocarbons and buoyant gross pollutants. The minimum sediment & petroleum hydrocarbon storage capacity shall be as follows:

2.1.1	4 ft (1219 mm) Diameter OGS Units:	1.19 m ³ sediment / 265 L oil
	6 ft (1829 mm) Diameter OGS Units:	3.48 m ³ sediment / 609 L oil
	8 ft (2438 mm) Diameter OGS Units:	8.78 m ³ sediment / 1,071 L oil
	10 ft (3048 mm) Diameter OGS Units:	17.78 m ³ sediment / 1,673 L oil
	12 ft (3657 mm) Diameter OGS Units:	31.23 m ³ sediment / 2,476 L oil

PART 3 – PERFORMANCE & DESIGN

3.1 GENERAL

The OGS stormwater quality treatment device shall be verified in accordance with ISO 14034:2016 Environmental management – Environmental technology verification (ETV). The OGS stormwater quality treatment device shall

Stormceptor® EF Sizing Report

remove oil, sediment and gross pollutants from stormwater runoff during frequent wet weather events, and retain these pollutants during less frequent high flow wet weather events below the insert within the OGS for later removal during maintenance. The Manufacturer shall have at least ten (10) years of local experience, history and success in engineering design, manufacturing and production and supply of OGS stormwater quality treatment device systems, acceptable to the Engineer of Record.

3.2 SIZING METHODOLOGY

The OGS device shall be engineered, designed and sized to provide stormwater quality treatment based on treating a minimum of 90 percent of the average annual runoff volume and a minimum removal of an annual average 60% of the sediment (TSS) load based on the Particle Size Distribution (PSD) specified in the sizing report for the specified device. Sizing of the OGS shall be determined by use of a minimum ten (10) years of local historical rainfall data provided by Environment Canada. Sizing shall also be determined by use of the sediment removal performance data derived from the ISO 14034 ETV third-party verified laboratory testing data from testing conducted in accordance with the Canadian ETV protocol Procedure for Laboratory Testing of Oil-Grit Separators, as follows:

3.2.1 Sediment removal efficiency for a given surface loading rate and its associated flow rate shall be based on sediment removal efficiency demonstrated at the seven (7) tested surface loading rates specified in the protocol, ranging 40 L/min/m² to 1400 L/min/m², and as stated in the ISO 14034 ETV Verification Statement for the OGS device.

3.2.2 Sediment removal efficiency for surface loading rates between 40 L/min/m² and 1400 L/min/m² shall be based on linear interpolation of data between consecutive tested surface loading rates.

3.2.3 Sediment removal efficiency for surface loading rates less than the lowest tested surface loading rate of 40 L/min/m² shall be assumed to be identical to the sediment removal efficiency at 40 L/min/m². No extrapolation shall be allowed that results in a sediment removal efficiency that is greater than that demonstrated at 40 L/min/m².

3.2.4 Sediment removal efficiency for surface loading rates greater than the highest tested surface loading rate of 1400 L/min/m² shall assume zero sediment removal for the portion of flow that exceeds 1400 L/min/m², and shall be calculated using a simple proportioning formula, with 1400 L/min/m² in the numerator and the higher surface loading rate in the denominator, and multiplying the resulting fraction times the sediment removal efficiency at 1400 L/min/m².

The OGS device shall also have sufficient annual sediment storage capacity as specified and calculated in Section 2.1.

3.3 CANADIAN ETV or ISO 14034 ETV VERIFICATION OF SCOUR TESTING

The OGS device shall have Canadian ETV or ISO 14034 ETV Verification of third-party scour testing conducted in accordance with the Canadian ETV Program's **Procedure for Laboratory Testing of Oil-Grit Separators**.

3.3.1 To be acceptable for on-line installation, the OGS device must demonstrate an average scour test effluent concentration less than 10 mg/L at each surface loading rate tested, up to and including 2600 L/min/m².

3.4 LIGHT LIQUID RE-ENTRAINMENT SIMULATION TESTING

The OGS device shall have Canadian ETV or ISO 14034 ETV Verification of completed third-party Light Liquid Re-entrainment Simulation Testing in accordance with the Canadian ETV **Program's Procedure for Laboratory Testing of Oil-Grit Separators**, with results reported within the Canadian ETV or ISO 14034 ETV verification. This re-entrainment testing is conducted with the device pre-loaded with low density polyethylene (LDPE) plastic beads as a surrogate for light liquids such as oil and fuel. Testing is conducted on the same OGS unit tested for sediment removal to

Stormceptor® EF Sizing Report

assess whether light liquids captured after a spill are effectively retained at high flow rates.

3.4.1 For an OGS device to be an acceptable stormwater treatment device on a site where vehicular traffic occurs and the potential for an oil or fuel spill exists, the OGS device must have reported verified performance results of greater than 99% cumulative retention of LDPE plastic beads for the five specified surface loading rates (ranging 200 L/min/m² to 2600 L/min/m²) in accordance with the Light Liquid Re-entrainment Simulation Testing within the Canadian ETV Program's **Procedure for Laboratory Testing of Oil-Grit Separators**. However, an OGS device shall not be allowed if the Light Liquid Re-entrainment Simulation Testing was performed with screening components within the OGS device that are effective at retaining the LDPE plastic beads, but would not be expected to retain light liquids such as oil and fuel.

Design Brief

Hospital Link Storm Drainage System Alta Vista Transportation Corridor

ADDENDUM

prepared for:



prepared by:

Delcan
a PARSONS Company
1223 Michael Street
Suite 100
Ottawa, ON K1J 7T2

TO3016EOD

August 13, 2014

TABLE OF CONTENTS

1 INTRODUCTION 1

2 STORMWATER MANAGEMENT PLAN 1

 2.1. VORTECHS 3..... 1

 2.2. Final Stormwater Management Plan 1

 2.3. Facility Details..... 2

3 SUMMARY 2

LIST OF TABLES

Table 1: Stormwater Management Vortechs No. 3..... 2

LIST OF APPENDICES

- Appendix A Future AVTC SWMHYMO Logic Charts
- Appendix B Future AVTC SWMHYMO Input File (100 year)
- Appendix C Future AVTC SWMHYMO Output File (100 year)

1 INTRODUCTION

Drainage and stormwater management for the portion of the Alta Vista Transportation Corridor that drains towards the Rideau River with specific emphasis on the works to be implemented for the Phase 1 Hospital Link is documented in:

- *Design Brief, Hospital Link Storm Drainage System, Alta Vista Transportation Corridor* prepared by Delcan Corporation and dated May 21, 2014.

The proposed stormwater management for the Hospital Link consists of two hydrodynamic separators. The proposed hydrodynamic separators would be Vortechs units (Contech Engineered Solutions) sized to provide the required water quality control.

- VORTECHS 1 – located adjacent to the Hospital Lands. This hydrodynamic separator would receive the minor system flows from the AVTC roadway drainage system upstream to Smyth Road. Unit sized to provide Level 1 – 80% TSS removal.
- VORTECHS 2 – located adjacent to the Hospital Lands. This hydrodynamic separator would receive the minor and major system flows from the existing Hospital Lands. Unit sized to provide 55% TSS removal.

As part of discussions with the National Capital Commission (NCC), MOE Ottawa District Office, and Rideau Valley Conservation Authority (RVCA), it was agreed that a third hydrodynamic separator would be installed to further enhance the overall water quality control.

This Addendum has been prepared to specifically address the inclusion of a third hydrodynamic separator as part of the Hospital Link.

2 STORMWATER MANAGEMENT PLAN

2.1. VORTECHS 3

As noted in Section 1 a third hydrodynamic separator will be included in the Hospital Link to further enhance the water quality control. The details are as follows:

- VORTECHS 3 – Located near the existing Moses Pepper Drain outlet. This hydrodynamic separator would receive major and minor system flow from the Hospital Link between Hincks Lane and the newly aligned Riverside Drive. The unit is sized to provide 90% TSS removal.

2.2. Final Stormwater Management Plan

A drainage schematic showing the location of the hydrodynamic separators and the contributing areas is included in Appendix B. There are 3.66 ha of the AVTC (Areas B and C) located between Vortechs 1/2 and Vortechs 3. This section drains to the low point located under the new railway crossing and there is limited space to locate, operate and maintain a hydrodynamic separator. In addition a small area (0.25 ha – Area E) at the connection between the Hospital Link and Riverside Drive at Hincks Lane will continue to drain to the existing storm drainage system along Riverside Drive. To compensate for uncontrolled drainage for these two sections of the AVTC (3.91 ha), the runoff from the existing hospital lands (34.4 ha), which currently discharges without any water quality control, will be

captured and treated by Vortechs 2. Providing water quality treatment for the hospital lands (34.4 ha; 64% impervious; and 55% TSS removal) provides over 4 times more TSS removal than treating the AVTC catchment area (3.9 ha; 89% impervious; and 80% TSS removal) located downstream of the hydrodynamic separators. In lieu of treating the downstream AVTC areas, treating runoff from the current hospital lands will provide a net gain in contaminant removal beyond the amount of contaminants estimated to be introduced by the construction of the new AVTC roadway.

2.3. Facility Details

The details of Vortechs Unit 3 are shown in Table 1 and the efficiency of the unit is documented in Appendix A. Updated plan and profile drawings showing Vortechs 3 are included in Appendix C.

Table 1: Stormwater Management Vortechs No. 3

		VORTECHS No. 3
Model Number		11000
Contributing Area	ha	1.73
Imperviousness	%	86
Runoff Coefficient		0.80
Dimensions	m	4.9L x 3.0W x 2.1H
Net Annual Load Removal Efficiency	%	90

3 SUMMARY

The overall drainage and stormwater management for the AVTC has been documented in the May 2014 Design Brief. This addendum updates the original stormwater management plan to include a third hydrodynamic separator. The three hydrodynamic separators will provide a net gain in contaminant removal beyond the amount of contaminants estimated to be introduced by the construction of the new AVTC roadway.



Appendix A

Vortechs 3 Details

C:\USERS\FISHERS\DESKTOP\LOGO UPDATE\VORTECHS DIM UPDATE\VX-11000-DTL.DWG 8/28/2012 11:54 AM

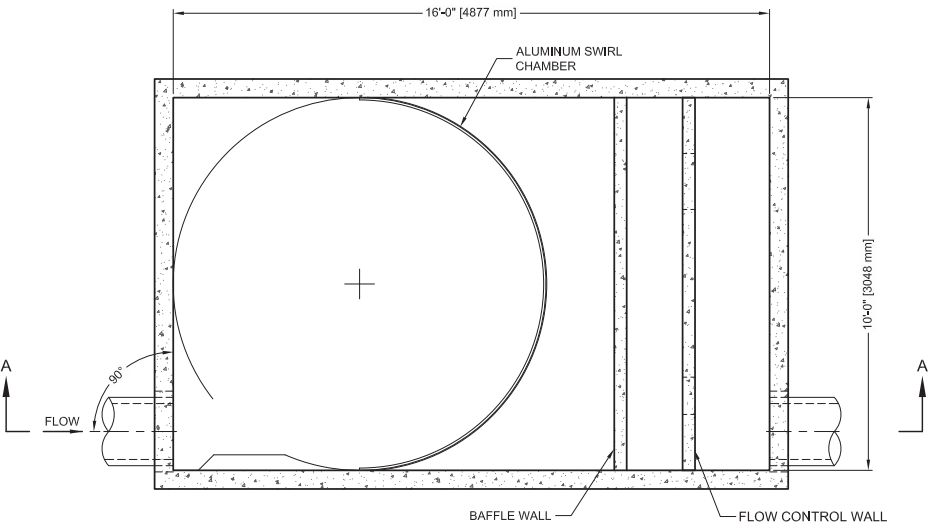

SECTION B-B

VORTECHS 11000 DESIGN NOTES

VORTECHS 11000 RATED TREATMENT CAPACITY IS 17.5 CFS, OR PER LOCAL REGULATIONS. IF THE SITE CONDITIONS EXCEED RATED TREATMENT CAPACITY, AN UPSTREAM BYPASS STRUCTURE IS REQUIRED.

THE STANDARD INLET/OUTLET CONFIGURATION IS SHOWN. FOR OTHER CONFIGURATION OPTIONS, PLEASE CONTACT YOUR CONTECH CONSTRUCTION PRODUCTS REPRESENTATIVE. www.contech-cpl.com

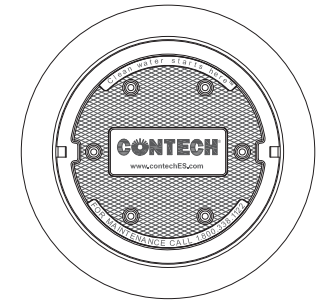

FRAME AND COVER
(DIAMETER VARIES)
N.T.S.

SITE SPECIFIC DATA REQUIREMENTS	
STRUCTURE ID	*
WATER QUALITY FLOW RATE (CFS)	*
PEAK FLOW RATE (CFS)	*
RETURN PERIOD OF PEAK FLOW (YRS)	*
PIPE DATA:	
INLET PIPE 1	I.E. MATERIAL DIAMETER
INLET PIPE 2	* * *
OUTLET PIPE	* * *
RIM ELEVATION	
*	
ANTI-FLOTATION BALLAST	WIDTH HEIGHT
	* *
NOTES/SPECIAL REQUIREMENTS:	
* PER ENGINEER OF RECORD	

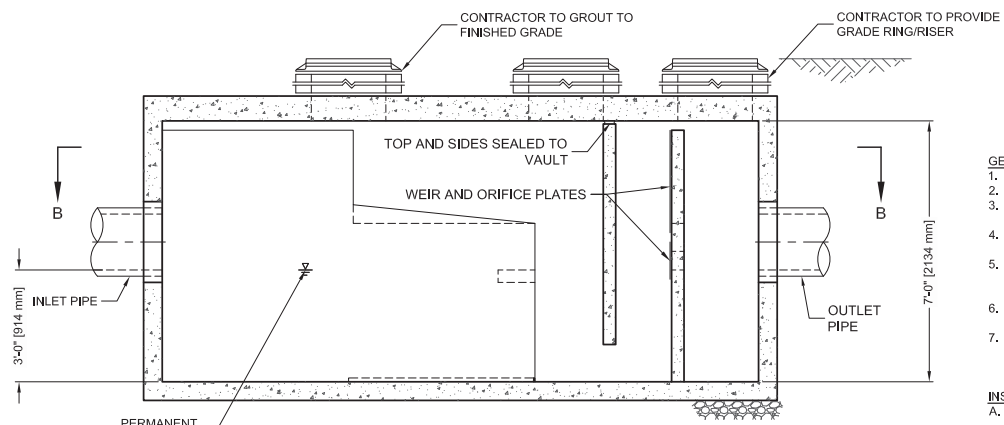

SECTION A-A

- GENERAL NOTES**
- CONTECH TO PROVIDE ALL MATERIALS UNLESS NOTED OTHERWISE.
 - DIMENSIONS MARKED WITH () ARE REFERENCE DIMENSIONS. ACTUAL DIMENSIONS MAY VARY.
 - FOR FABRICATION DRAWINGS WITH DETAILED STRUCTURE DIMENSIONS AND WEIGHT, PLEASE CONTACT YOUR CONTECH ENGINEERED SOLUTIONS LLC REPRESENTATIVE. www.contechES.com
 - VORTECHS WATER QUALITY STRUCTURE SHALL BE IN ACCORDANCE WITH ALL DESIGN DATA AND INFORMATION CONTAINED IN THIS DRAWING.
 - STRUCTURE SHALL MEET AASHTO HS20 AND CASTINGS SHALL MEET AASHTO M306 LOAD RATING, ASSUMING GROUNDWATER ELEVATION AT, OR BELOW, THE OUTLET PIPE INVERT ELEVATION. ENGINEER OF RECORD TO CONFIRM ACTUAL GROUNDWATER ELEVATION.
 - INLET PIPE(S) MUST BE PERPENDICULAR TO THE VAULT AND AT THE CORNER TO INTRODUCE THE FLOW TANGENTIALLY TO THE SWIRL CHAMBER. DUAL INLETS NOT TO HAVE OPPOSING TANGENTIAL FLOW DIRECTIONS.
 - OUTLET PIPE(S) MUST BE DOWN STREAM OF THE FLOW CONTROL BAFFLE AND MAY BE LOCATED ON THE SIDE OR END OF THE VAULT. THE FLOW CONTROL WALL MAY BE TURNED TO ACCOMMODATE OUTLET PIPE KNOCKOUTS ON THE SIDE OF THE VAULT.
- INSTALLATION NOTES**
- ANY SUB-BASE, BACKFILL DEPTH, AND/OR ANTI-FLOTATION PROVISIONS ARE SITE-SPECIFIC DESIGN CONSIDERATIONS AND SHALL BE SPECIFIED BY ENGINEER OF RECORD.
 - CONTRACTOR TO PROVIDE EQUIPMENT WITH SUFFICIENT LIFTING AND REACH CAPACITY TO LIFT AND SET THE VORTSENTRY HS MANHOLE STRUCTURE (LIFTING CLUTCHES PROVIDED).
 - CONTRACTOR TO INSTALL JOINT SEALANT BETWEEN ALL STRUCTURE SECTIONS AND ASSEMBLE STRUCTURE.
 - CONTRACTOR TO PROVIDE, INSTALL, AND GROUT PIPES. MATCH PIPE INVERTS WITH ELEVATIONS SHOWN.
 - CONTRACTOR TO TAKE APPROPRIATE MEASURES TO ASSURE UNIT IS WATER TIGHT, HOLDING WATER TO FLOWLINE INVERT MINIMUM. IT IS SUGGESTED THAT ALL JOINTS BELOW PIPE INVERTS ARE GROUTED.



CONTECH
ENGINEERED SOLUTIONS LLC
www.contechES.com
9025 Centre Pointe Dr., Suite 400, West Chester, OH 45069
800-338-1122 513-645-7000 513-645-7993 FAX

VORTECHS 11000
STANDARD DETAIL

**VORTECHS SYSTEM® ESTIMATED NET ANNUAL SOLIDS LOAD REDUCTION
BASED ON AN AVERAGE PARTICLE SIZE OF 80 MICRONS**



**ALTA VISTA TC - SWM PONDS
OTTAWA, ON
MODEL 11000 IN-LINE
SITE DESIGNATION POND 3**

Design Ratio¹ =
$$\frac{(1.73 \text{ hectares}) \times (0.8) \times (2.775)}{(7.3 \text{ m}^2)} = 0.52$$

Rainfall Intensity mm/hr	Operating Rate² % of capacity	Flow Treated (l/s)	% Total Rainfall Volume ³	Rmvl. Effic⁴ (%)	Rel. Effic⁵ (%)
0.5	0.4	1.9	10.7%	100.0%	10.7%
1.0	0.8	3.9	9.3%	100.0%	9.3%
1.5	1.2	5.8	10.3%	98.0%	10.1%
2.0	1.6	7.7	8.6%	98.0%	8.4%
2.5	2.0	9.7	6.7%	98.0%	6.6%
3.0	2.3	11.6	5.8%	98.0%	5.7%
3.6	2.7	13.5	5.0%	98.0%	4.9%
4.1	3.1	15.5	4.4%	98.0%	4.3%
4.6	3.5	17.4	2.3%	98.0%	2.3%
5.1	3.9	19.3	4.2%	98.0%	4.1%
6.4	4.9	24.2	7.4%	98.0%	7.2%
7.6	5.9	29.0	4.0%	98.0%	4.0%
8.9	6.8	33.8	3.5%	98.0%	3.4%
10.2	7.8	38.7	1.8%	97.6%	1.8%
11.4	8.8	43.5	3.8%	96.9%	3.7%
12.7	9.8	48.3	1.4%	96.3%	1.4%
19.1	14.6	72.5	5.2%	92.8%	4.8%
25.4	19.5	96.6	2.4%	88.0%	2.1%
38.1	29.3	145.0	2.3%	82.6%	1.9%
					96.7%

Predicted Annual Runoff Volume Treated = 92.8%
Assumed Removal Efficiency of remaining % = 0.0%
Removal Efficiency Adjustment⁵ = 6.5%
Predicted Net Annual Load Removal Efficiency = 90%

1 - Design Ratio = (Total Drainage Area) x (Runoff Coefficient) x (Rational Method Conversion) / Grit Chamber Area
 - The Total Drainage Area and Runoff Coefficient are specified by the site engineer.
 - The rational method conversion based on the units in the above equation is 2.775.
 2 - Operating Rate (% of capacity) = percentage of peak operating rate of 68 l/s/m².
 3 - Based on 10 years of rainfall data from Canadian Station 6105976, Ottawa CDA, ON
 4 - Based on Contech Construction Products laboratory verified removal of an average particle size of 80 microns (see Vortechs Guide).
 5- Reduction due to use of 60-minute data for a site that has a time of concentration less than 30-minutes.

Calculated by: JAK 6/26 Checked by:

Appendix B
Drainage Schematic

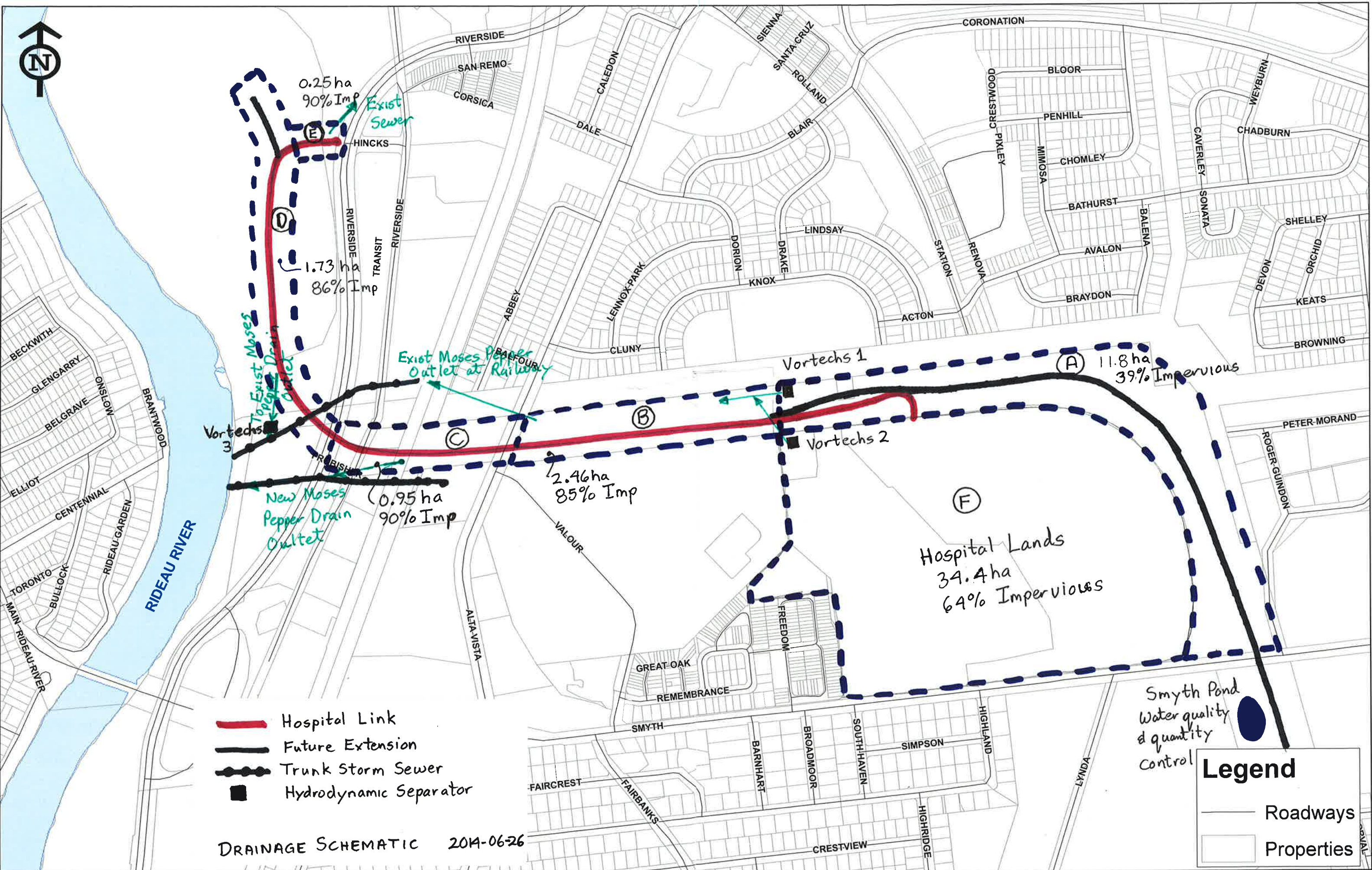

DRAINAGE SCHEMATIC 2014-06-26

Appendix C

Hospital Link – Updated Plan and Profile Drawings

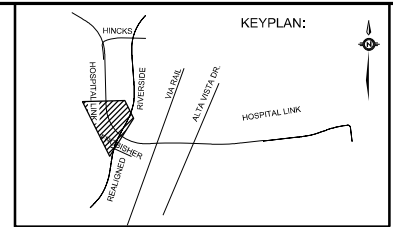

ALTA VISTA HOSPITAL LINK

**GRADING & DRAINAGE 3
HOSPITAL LINK - PLAN
STA. 2+660 TO STA. 2+880**

Contract No. **ISD10-5036** Draw. No. **027**
Sheet **27** of

Asset No.
Asset Group **ISD**

W. R. NEWELL, P.Eng. B. KENNY, P.Eng.
General Manager Project Manager

Delcan

Des. MDM Chk'd. DSG
Dwn. MDM Chk'd. DAH
Utility Circ. No. Index No.
Const. Inspector 15378

Scale: **HORIZONTAL**
0m 5 10 20

NOTE: The location of utilities is approximate only, the exact location should be determined by consulting the municipal authorities and utility companies concerned. The contractor shall prove the location of utilities and shall be responsible for adequate protection from damage.

No.	Description	By	Date (dd/mm/yy)
1	FOR CLIENT REVIEW	D.A.H.	26/11/2013
2	FOR PRE-QUALIFICATION PURPOSES ONLY	D.A.H.	09/12/2013
3	ISSUED FOR TENDER	D.A.H.	15/05/2014
4	VORTECHS 3	D.R.Y.	30/07/2014



CATCH BASIN DATA

NO.	STATION	OFFSET	COVER	STRUCTURE	ELEVATION	
					T/FRAME	LOW/INV.
CB 27	2+760.00	2.50 RT	S22/S23	705.010 B	64.47	63.01
CB 28	2+700.00	2.50 RT	S22/S23	705.010 B	64.36	62.90
DICB 29	2+719.94	2.60 LT	403.010	705.030 A	63.74	62.34
CB 30	2+710.00	2.50 RT	S22/S23	705.010 B	64.73	63.27
CB 31	2+720.00	2.50 RT	S19	705.010 B	64.23	62.85
CB 32	2+745.00	2.50 RT	S19	705.010 B	64.54	63.16
CB 33	2+770.00	2.50 RT	S19	705.010 B	65.14	63.76
CB 34	2+790.00	2.50 RT	S19	705.010 B	65.85	64.47
CB 35	2+809.00	2.50 RT	S19	705.010 B	66.56	65.16

- OFFSETS ARE FROM CONTROL LINE TO FACE OF CURB FOR ALL ROAD CATCH BASINS
- OFFSETS ARE FROM CONTROL LINE TO CENTER OF STRUCTURE FOR ALL DITCH INLET CATCH BASINS
- DICB - SLOPE OF GRATE 3:1 UNLESS OTHERWISE NOTED

CATCH BASIN CONNECTION

LOCATION	DIA. (mm)	TYPE	LENGTH (m)	INVERT ELEVATIONS	
				UPSTR.	DOWNSTR.
CB 27 - MAIN	200	PVC SDR35	7.2	63.01	58.95
CB 28 - MAIN	200	PVC SDR35	6.1	62.90	58.86
DICB 29 - MAIN	250	PVC SDR35	1.6	62.34	58.84
CB 30 - MAIN	200	PVC SDR35	5.0	63.27	58.83
CB 31 - MAIN	200	PVC SDR35	3.8	62.85	58.80
CB 32 - MAIN	200	PVC SDR35	4.3	63.16	58.71
CB 33 - MAIN	200	PVC SDR35	14.8	63.76	60.68
CB 34 - CB/MH206	200	PVC SDR35	8.15	64.47	61.21
CB 35 - CB/MH 206	200	PVC SDR35	11.2	65.16	65.07

STORM MAINTENANCE HOLE DATA

NO.	STATION	OFFSET	COVER	STRUCTURE	ELEVATION	
					T/FRAME	LOW/INV.
MHST 201	2+713.82	2.46 LT	S24,1/S25	701.011	64.13	58.28
MHST 200	2+789.30	33.97 RT	S24,1/S25	701.011 W/D	62.82	57.00
CB/MH 206	2+798.00	2.94 RT	S19	701.010	66.17	61.37
MHST207	2+795.08	38.94 RT	S19	11000	62.78	56.98
MHST30503	2+807.78	56.09 RT	EXIST.	EXIST.	61.96	EXIST.

- OFFSETS ARE FROM CONTROL LINE TO CENTRE OF STRUCTURE
- SLF DENOTES SELF LEVELING FRAME
- W/D DENOTES STRUCTURE WITH DROP PIPE

**FOR BIDDING PURPOSES ONLY
NOT FOR CONSTRUCTION
May 15, 2014**

TITLE FRAME: 789mm x 634mm City of Ottawa 2008
 PLOT DATE: 5/15/2014 9:50:01 AM
 PLOT SCALE: 1:1
 Last Saved: 13/08/2014 9:50:01 AM
 Consultant's Information: P:\ISD\10\5036\ISD\10-5036-GRD-03-PLAN.Dwg

STORM SEWER DESIGN SHEET



uOttawa Advanced Medical Research Centre Building
 451 Smyth Road
 Project: CA0009956.0165
 Date: February 2024

LOCATION				AREA (Ha)						RATIONAL DESIGN FLOW							PROPOSED SEWER DATA										
STREET	AREA ID	FROM	TO	C= 0.20	C= 0.35	C= 0.50	C= 0.75	C= 0.80	C= 0.90	IND 2.78AC	CUM 2.78 AC	INLET (min)	TOTAL (min)	i (2) (mm/hr)	i (5) (mm/hr)	i (100) (mm/hr)	2yr PEAK FLOW (L/s)	DESIGN FLOW (L/s)	MATERIAL PIPE	SIZE (mm)	SLOPE (%)	LENGTH (m)	CAPACITY (l/s)	VELOCITY (m/s)	TIME IN PIPE	AVAIL CAP (2yr) (L/s)	(%)
POST-DEVELOPMENT																											
	A-18	CB 20	STMH 109	0.012					0.140	0.357	0.357	10.00	10.38	76.81	104.19	178.56	27.42	27.42	PVC DR-35	200	1.00	23.80	32.83	1.04	0.38	5.42	16.50%
	A-17	CB 01	MAIN	0.007					0.135	0.342	0.342	10.00	10.08	76.81	104.19	178.56	26.24	26.24	PVC DR-35	200	2.00	7.50	46.43	1.48	0.08	20.19	43.48%
	A-16	EX-CB 02	MAIN	0.013					0.052	0.137	0.137	10.00	10.13	76.81	104.19	178.56	10.55	10.55	PVC DR-35	200	2.00	11.70	46.43	1.48	0.13	35.88	77.28%
	A-15	CB 02	MAIN	0.011					0.046	0.120	0.120	10.00	10.05	76.81	104.19	178.56	9.25	9.25	PVC DR-35	200	2.00	4.00	46.43	1.48	0.05	37.18	80.08%
	A-14	CB 03	MAIN	0.015					0.055	0.146	0.146	10.00	10.14	76.81	104.19	178.56	11.18	11.18	PVC DR-35	200	2.00	12.10	46.43	1.48	0.14	35.25	75.92%
		STMH 109	STMH 108						0.000	1.102	1.102	10.38	11.77	75.38	102.23	175.16	83.06	83.06	CONC.	525	0.20	73.90	192.52	0.89	1.39	109.46	56.86%
	A-20	CB 04	MAIN	0.026					0.030	0.090	0.090	10.00	10.31	76.81	104.19	178.56	6.92	6.92	PVC DR-35	200	1.00	19.60	32.83	1.04	0.31	25.91	78.92%
	A-12	CB 05	MAIN	0.029					0.075	0.204	0.204	10.00	10.15	76.81	104.19	178.56	15.70	15.70	PVC DR-35	200	2.00	13.60	46.43	1.48	0.15	30.74	66.20%
	A-13	CB 06	MAIN	0.002					0.046	0.117	0.117	10.00	10.06	76.81	104.19	178.56	8.95	8.95	PVC DR-35	200	2.00	5.70	46.43	1.48	0.06	37.48	80.71%
	A-21	CB 08	MAIN	0.029					0.046	0.131	0.131	10.00	10.05	76.81	104.19	178.56	10.03	10.03	PVC DR-35	200	1.00	3.10	32.83	1.04	0.05	22.80	69.44%
	A-22	CB 13	MAIN	0.017					0.043	0.116	0.116	10.00	10.06	76.81	104.19	178.56	8.94	8.94	PVC DR-35	200	1.00	4.00	32.83	1.04	0.06	23.89	72.76%
		STMH 108	SMALL POND						0.000	1.760	1.760	11.77	12.99	70.63	95.71	163.88	124.31	124.31	CONC.	525	0.24	71.60	210.90	0.97	1.23	86.59	41.06%
		SMALL POND	BIG POND						0.000	1.760	1.760	12.99	13.10	66.95	90.66	155.16	117.84	117.84	HDPE	525	1.00	13.10	430.50	1.99	0.11	312.66	72.63%
	A-6	BIG POND	EFO6	0.085					0.017	0.090	1.850	13.10	13.25	66.64	90.24	154.43	123.28	123.28	PVC DR-35	375	1.40	16.10	207.66	1.88	0.14	84.38	40.63%
*SEE NOTE		EFO6	EX. STMH						0.000	1.850	1.850	13.25	13.49	66.25	89.69	153.49	122.55	122.55	PVC DR-35	375	1.25	26.40	196.22	1.77	0.25	73.68	37.55%
	A-9	CB 10	CBMH 102	0.000					0.033	0.083	0.083	10.00	10.25	76.81	104.19	178.56	6.34	6.34	PVC DR-35	200	1.00	15.80	32.83	1.04	0.25	26.49	80.68%
	A-11	CB 12	MAIN	0.006					0.036	0.093	0.093	10.00	10.02	76.81	104.19	178.56	7.16	7.16	PVC DR-35	200	2.00	1.50	46.43	1.48	0.02	39.27	84.58%
	A-10	CBMH 102	STMH 102 / CHAMBERS	0.003					0.023	0.059	0.235	10.25	10.50	75.85	102.88	176.29	17.82	17.82	CONC.	450	0.50	19.20	201.80	1.27	0.25	183.98	91.17%
	A-7	CB 14	CBMH 108	0.005					0.054	0.137	0.137	10.00	10.41	76.81	104.19	178.56	10.53	10.53	PVC DR-35	200	1.00	25.50	32.83	1.04	0.41	22.30	67.93%
	A-8	CBMH 108	STMH 114 / CHAMBERS	0.002					0.043	0.107	0.244	10.41	10.85	75.28	102.09	174.92	18.39	18.39	PVC DR-35	250	0.50	22.90	42.09	0.86	0.45	23.70	56.31%
	A-4	CB 15	STMH 114 / CHAMBERS	0.120					0.028	0.137	0.137	10.00	10.19	76.81	104.19	178.56	10.51	10.51	PVC DR-35	200	2.00	17.20	46.43	1.48	0.19	35.92	77.36%
		STMH 114 / CHAMBERS	STORM CHAMBERS						0.000	0.381	10.85	10.85	10.85	73.68	99.90	171.12	28.08	28.08									
**SEE NOTE		STMH 112 / CHAMBERS	EFO4						0.000	0.616	10.85	10.99	10.99	73.68	99.90	171.12	45.40	45.40	PVC DR-35	375	1.00	13.30	175.51	1.59	0.14	130.11	74.13%
		EFO4	EX-STMH						0.000	0.616	10.99	11.11	11.11	73.19	99.23	169.97	45.10	45.10	PVC DR-35	375	1.00	11.50	175.51	1.59	0.12	130.41	74.30%
***SEE NOTE	A-23	CB 07	Ex. MAIN	0.011					0.089	0.229	0.229	10.00	10.12	76.81	104.19	178.56	17.59	17.59	PVC DR-35	200	2.00	11.00	46.43	1.48	0.12	28.84	62.12%
†SEE NOTE	R1, R2	BLDG	Ex. STMH	0.000					0.537	1.344	1.344	10.00	10.07	76.81	104.19	178.56	103.19	103.19	PVC DR-35	300	2.00	7.80	136.89	1.93	0.07	33.70	24.62%
Definition:				Notes:								Designed:				Revision				Date							
Q=2.78CIA, where:				1. Mannings coefficient (n) = 0.013								Z.A				City Submission No. 1				2023-11-30							
Q = Peak Flow in Litres per Second (L/s)				2-YR Flow:												City Submission No. 2				2024-02-26							
A = Area in Hectares (Ha)				*Flow controlled to 52.15 l/s																							
i = Rainfall Intensity in millimeters per hour (mm/hr)				**Flow controlled to 2.9 l/s																							
i = 732.951/(TC+6.199)^0.810				***Flow controlled to 18.15 l/s																							
2 Year				†Flow from roofs controlled to 39.14 l/s																							
5 Year																											
100 Year																											
												Dwg. Reference:				File				Date:				Sheet No:			
												C110												1 of 1			