

**LEGEND**

---	SITE BOUNDARY
+104.00	EXISTING ELEVATION
●	EXISTING HYDRANT
⊕	EXISTING VALVE & VALVE BOX
---	EXISTING WATERMAIN
---	EXISTING SANITARY SEWER & MANHOLE
---	EXISTING STORM SEWER & MANHOLE
□	EXISTING CATCH BASIN
---	EXISTING DITCH CENTRELINE
---	EXISTING GAS LINE
---	EXISTING BELL LINE
---	EXISTING HYDRO LINE
---	EXISTING STREELIGHT LINE
●	EXISTING LIGHT STANDARD
---	EXISTING FENCE
●	EXISTING BOLLARD
●	HYDRANT
⊕	VALVE & VALVE BOX
---	FIRE DEPARTMENT CONNECTION
---	THRUST BLOCK
---	WATERMAIN
---	SANITARY SEWER & MANHOLE
---	STORM SEWER & MANHOLE
□	CATCH BASIN
---	SWALE
▲	BUILDING ENTRANCE

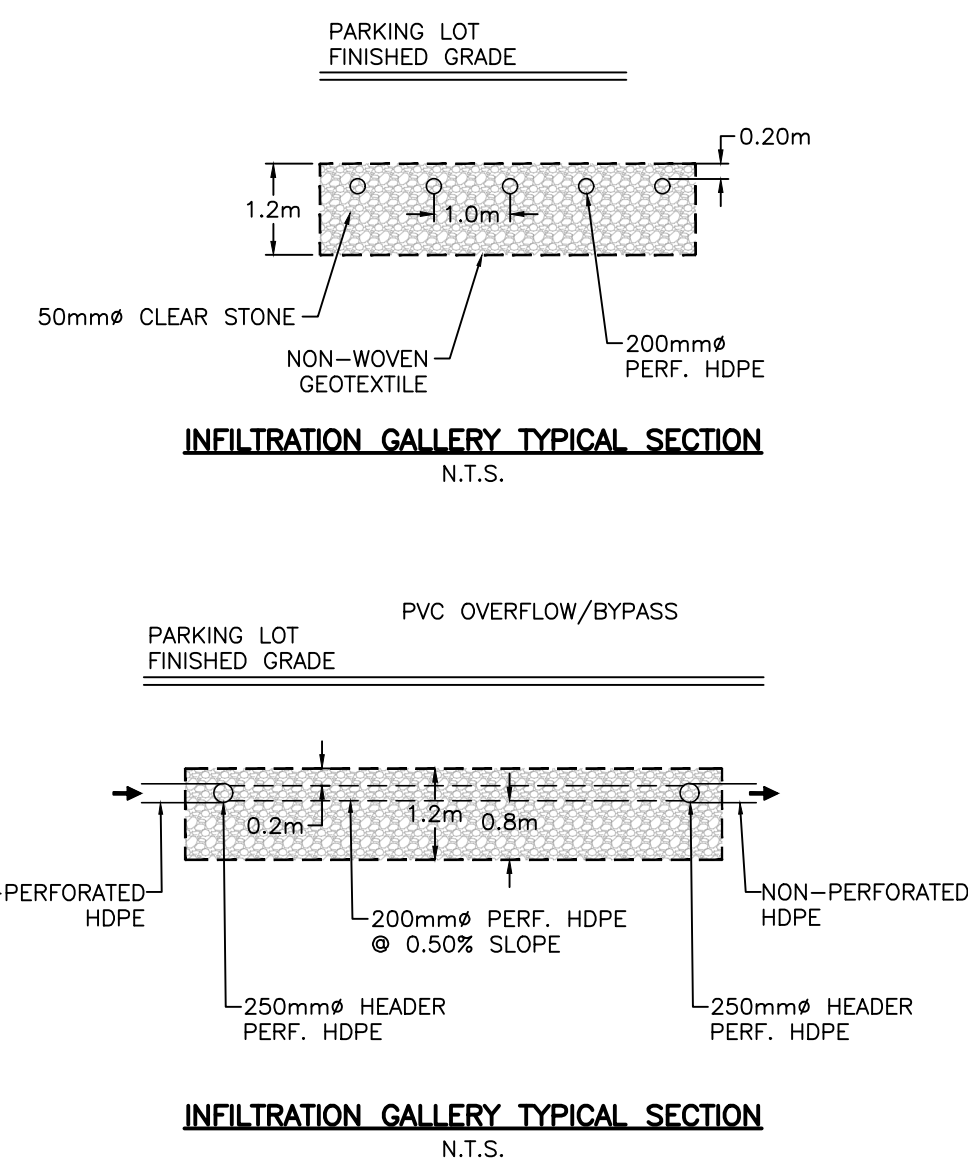

**INLET CONTROL DEVICE (ICD) TABLE**

STRUCTURE	MIN HEAD (m)	MIN FLOW (L/s)	MAX HEAD (m)	MAX FLOW (L/s)	ORIFICE TYPE
CBMH205	1.45	31.5	1.75	34.6	TEMPEST HF B
CBMH204	2.80	43.8	3.10	46.1	TEMPEST HF B
STMMH202	0.41	9.7	3.90	29.8	ORIFICE PLATE 85mm
CBMH203	3.04	15.6	3.34	16.4	TEMPEST LMF-100mm
CB02	3.50	4.3	3.78	4.5	TEMPEST LMF-50mm
CB01	3.40	14.9	3.79	15.8	TEMPEST LMF-95mm
STMMH201	0.21	11.6	2.94	43.3	ORIFICE PLATE 110mm
CBMH208	1.56	40.4	1.86	44.1	TEMPEST HF C
CB07	1.16	103.9	1.27	108.7	ORIFICE PLATE 215mm

**UTILITY CROSSING TABLE**

CROSSING No.	SERVICE	INVERT/OBVERT	SEPARATION (m)
1	SANITARY	112.98	0.50
	WATER	112.48	
2	CULVERT	116.15	4.55
	STORM	111.60	

**PRELIMINARY**  
 NOT FOR CONSTRUCTION

**NOTES**  
 THE POSITION OF ALL POLE LINES, CONDUITS, WATERMANS, SEWERS AND OTHER UNDERGROUND AND OVERGROUND UTILITIES AND STRUCTURES IS NOT NECESSARILY SHOWN ON THE CONTRACT DRAWINGS, AND WHERE SHOWN, THE ACCURACY OF THE POSITION OF SUCH UTILITIES AND STRUCTURES IS NOT GUARANTEED. BEFORE STARTING WORK, DETERMINE THE EXACT LOCATION OF ALL SUCH UTILITIES AND STRUCTURES AND ASSUME ALL LIABILITY FOR DAMAGE TO THEM.

PROPERTY BOUNDARIES ARE DERIVED FROM TOPOGRAPHIC SURVEY OF PART OF LOT 11 GORE BETWEEN CONCESSIONS 2 & 3 (RIDEAU FRONT), PART OF THE ROAD ALLOWANCE BETWEEN THE GORE BETWEEN CONCESSIONS 2 & 3 (RIDEAU FRONT) AND CONCESSION 3 (RIDEAU FRONT), GEOGRAPHIC TOWNSHIP OF GLOUCESTER, CITY OF OTTAWA. PREPARED BY FAIRHALL, MOFFATT & WOODLAND LTD. ONTARIO LAND SURVEYORS, REF: AD27800. ELEVATIONS ARE REFERRED TO GEODETIC DATUM (CGVD28).

NO.	REVISION DESCRIPTION	DATE	BY
2	REISSUED FOR SITE PLAN	26/02/24	CC
1	ISSUED FOR SITE PLAN	11/01/24	CC

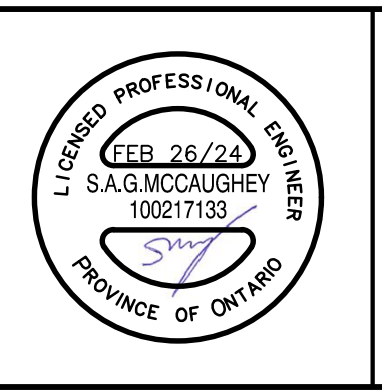
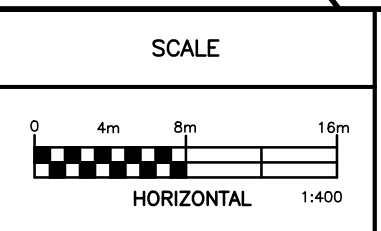

**Robinson Land Development**  
 350 Palladium Drive  
 Ottawa, ON K2V 1A8  
 (613) 592-6060 rcil.com

**DESIGN**

SM
CC
SM
CC
CC

**JENNINGS REAL ESTATE**  
**145 THAD JOHNSON PRIVATE**  
 CITY OF OTTAWA

**SERVICING PLAN**

PROJECT No. **23069**  
 SURVEY **FMW**  
 DATED **FEB 2024**  
 DWG. No. **23069-S1**

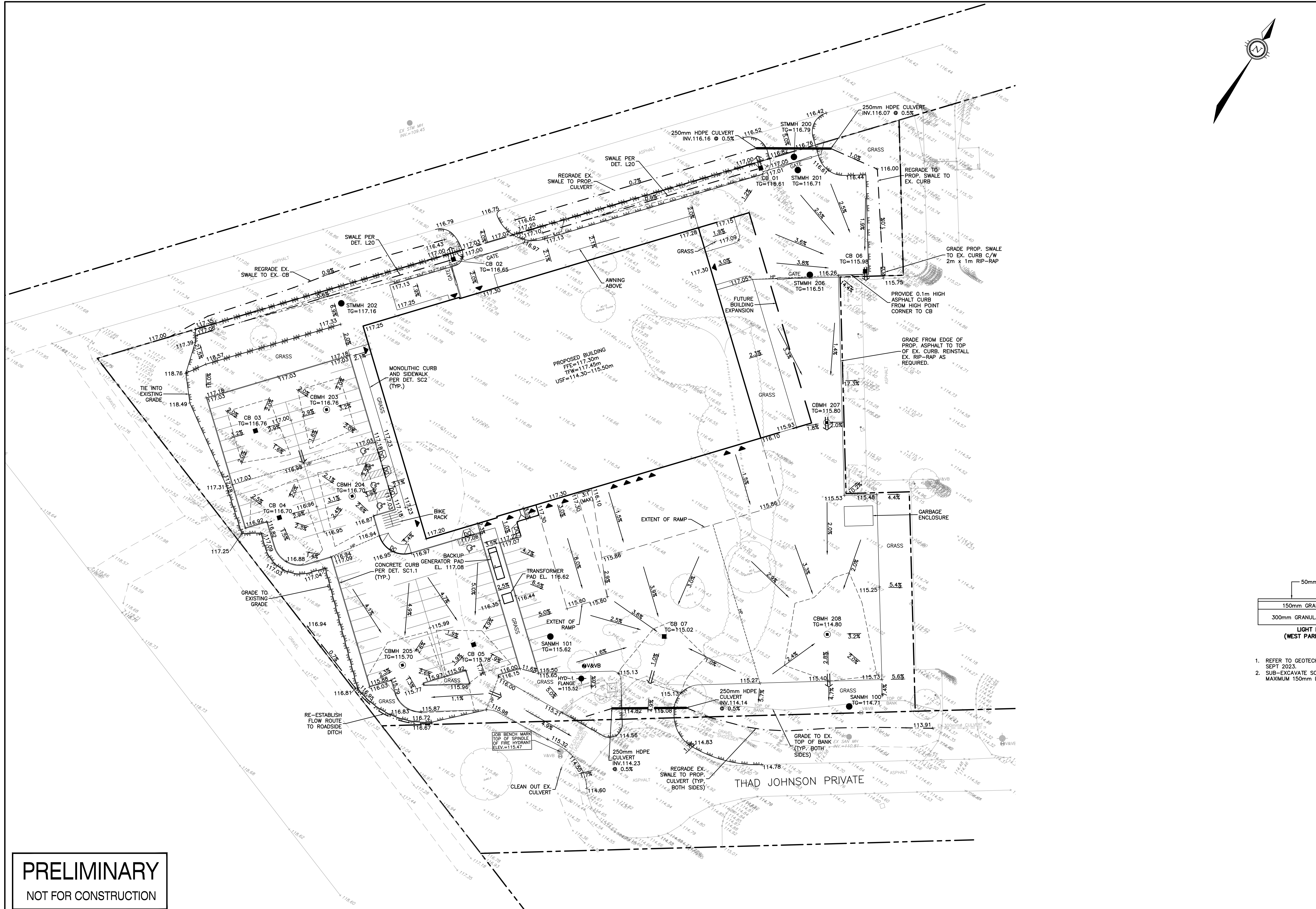
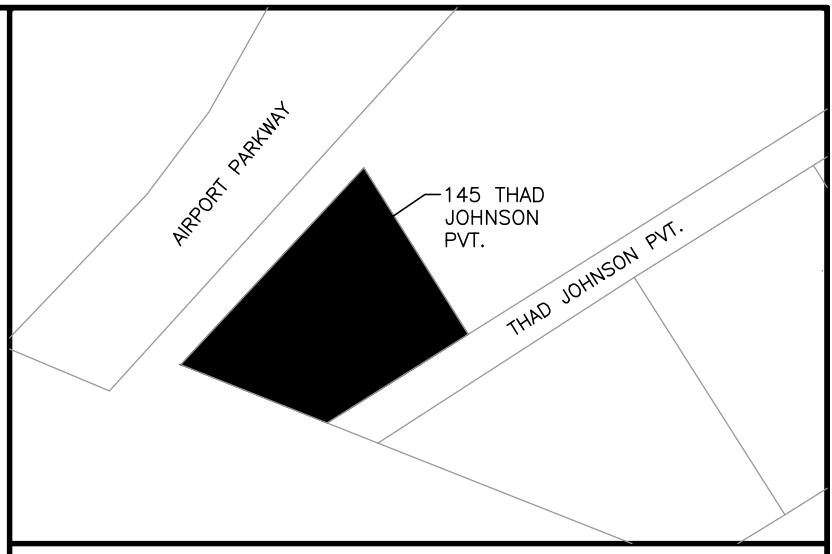

**KEY PLAN**

**LEGEND**

- SITE BOUNDARY
- +104.00 EXISTING ELEVATION
- EXISTING HYDRANT
- ⊕ V&VB EXISTING VALVE & VALVE BOX
- ⊙ EXISTING STORM/SANITARY MANHOLE
- EXISTING CATCH BASIN
- - - EXISTING DITCH CENTRELINE
- \*LS EXISTING LIGHT STANDARD
- x - x EXISTING FENCE
- +B EXISTING BOLLARD
- x 105.00 PROPOSED GRADE
- 2.0% PROPOSED SLOPE
- - - SWALE
- - - TERRACING (3H:1V MAX.)
- HYDRANT
- ⊕ V&VB VALVE & VALVE BOX
- ⊙ FIRE DEPARTMENT CONNECTION
- ⊙ STORM/SANITARY MANHOLE (AS NOTED)
- CATCH BASIN
- - - 100-YR PONDING
- ⇒ MAJOR OVERLAND FLOW PATH
- HP HIGH POINT
- ▲ BUILDING ENTRANCE

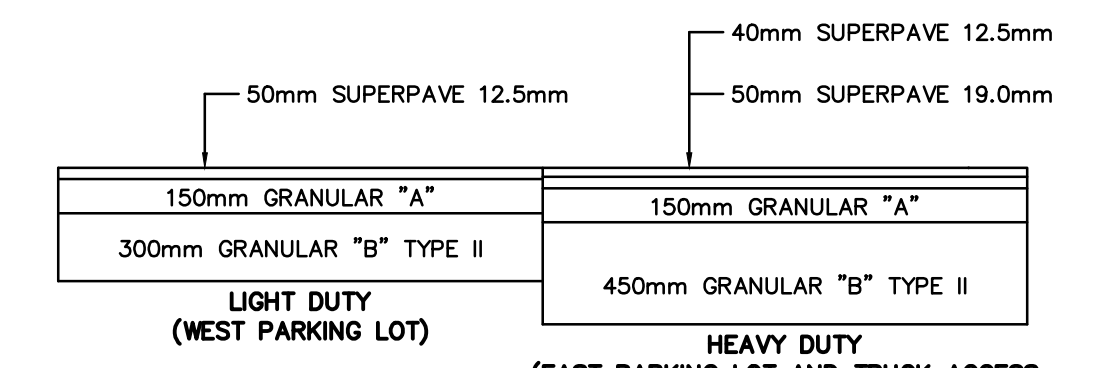

- REFER TO GEOTECHNICAL INVESTIGATION PREPARED BY PATERSON GROUP DATED SEPT 2023.
- SUB-EXCAVATE SOFT AREAS AND BACKFILL WITH GRANULAR 'B' COMPACTED IN MAXIMUM 150mm LIFTS OR AS OTHERWISE DIRECTED.

**PAVEMENT STRUCTURE DETAIL**

**SURFACE PONDING SUMMARY**

STRUCTURE	100-yr STORM	
	PONDING ELEVATION (m)	PONDING DEPTH (m)
CB01	117.00	0.39
CB02	116.99	0.34
CB03	116.92	0.16
CBMH203	116.92	0.16
CB04	116.90	0.20
CBMH204	116.90	0.20
CB05	115.96	0.18
CBMH205	115.96	0.26
CBMH208	115.10	0.30
CBMH209	115.13	0.12

**PRELIMINARY**  
NOT FOR CONSTRUCTION

**NOTES**  
THE POSITION OF ALL POLE LINES, CONDUITS, WATERMANS, SEWERS AND OTHER UNDERGROUND AND OVERGROUND UTILITIES AND STRUCTURES IS NOT NECESSARILY SHOWN ON THE CONTRACT DRAWINGS, AND WHERE SHOWN, THE ACCURACY OF THE POSITION OF SUCH UTILITIES AND STRUCTURES IS NOT GUARANTEED. BEFORE STARTING WORK, DETERMINE THE EXACT LOCATION OF ALL SUCH UTILITIES AND STRUCTURES AND ASSUME ALL LIABILITY FOR DAMAGE TO THEM.  
PROPERTY BOUNDARIES ARE DERIVED FROM TOPOGRAPHIC SURVEY OF PART OF LOT 11 GORE BETWEEN CONCESSIONS 2 & 3 (RIDEAU FRONT), PART OF THE ROAD ALLOWANCE BETWEEN THE GORE BETWEEN CONCESSIONS 2 & 3 (RIDEAU FRONT) AND CONCESSION 3 (RIDEAU FRONT), GEOGRAPHIC TOWNSHIP OF GLOUCESTER, CITY OF OTTAWA. PREPARED BY FAIRHALL, MOFFATT & WOODLAND LTD. ONTARIO LAND SURVEYORS, REF: AD27800. ELEVATIONS ARE REFERRED TO GEODETIC DATUM (CGVD25).

NO.	REVISION DESCRIPTION	DATE	BY
2	REISSUED FOR SITE PLAN	26/02/24	CC
1	ISSUED FOR SITE PLAN	11/01/24	CC

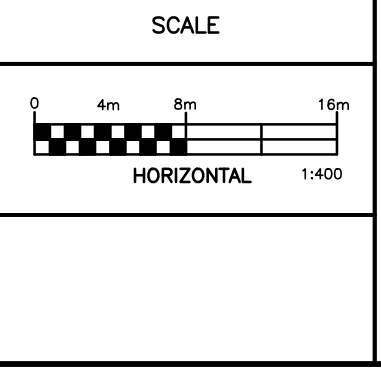

**Robinson Land Development**  
350 Palladium Drive  
Ottawa, ON K2V 1A8  
(613) 592-6060 rcil.com

DESIGN	SM
CHECKED	CC
DRAWN	SM
CHECKED	CC
APPROVED	CC

**JENNINGS REAL ESTATE**  
**145 THAD JOHNSON PRIVATE**  
**CITY OF OTTAWA**

**GRADING PLAN**

PROJECT No.	23069
SURVEY	FMW
DATED	FEB 2024
DWG. No.	23069-GR1

- GENERAL NOTES:**
1. ALL WORKS AND MATERIALS SHALL CONFORM TO THE LATEST REVISIONS OF THE STANDARDS AND SPECIFICATIONS OF THE CITY OF OTTAWA AND ONTARIO PROVINCIAL STANDARD DRAWINGS (OPSD) AND SPECIFICATIONS (OPSS), AS AMENDED BY THE CITY OF OTTAWA.
  2. THE CONTRACTOR SHALL CONFIRM THE LOCATION OF ALL EXISTING UTILITIES WITHIN THE SITE AND ADJACENT WORK AREAS. THE CONTRACTOR SHALL BE RESPONSIBLE FOR PROTECTING ALL EXISTING UTILITIES TO THE SATISFACTION OF THE AUTHORITY HAVING JURISDICTION. THE CONTRACTOR SHALL BE RESPONSIBLE FOR REPAIR OR REPLACEMENT OF ANY SERVICES OR UTILITIES DISTURBED DURING CONSTRUCTION, TO THE SATISFACTION OF THE AUTHORITY HAVING JURISDICTION.
  3. ALL DIMENSIONS AND ELEVATIONS SHALL BE CHECKED AND VERIFIED IN THE FIELD BY THE CONTRACTOR PRIOR TO THE START OF CONSTRUCTION. ANY DISCREPANCIES SHALL BE REPORTED IMMEDIATELY TO THE ENGINEER.
  4. DESIGN ELEVATIONS GIVEN ARE TO BE ADHERED TO WITH NO CHANGES WITHOUT PRIOR WRITTEN APPROVAL BY ROBINSON LAND DEVELOPMENT.
  5. ALL GROUND SURFACES SHALL BE EVENLY GRADED WITHOUT PONDING AREAS TO PROPOSED GRADES WHERE NOTED, AND EXISTING GRADES OTHERWISE.
  6. CONTRACTOR SHALL ADJUST FINAL GRADE OF EXISTING MAINTENANCE HOLES, VALVE BOXES, ETC. AS REQUIRED TO MATCH PROPOSED GRADES.
  7. ANY AREAS BEYOND THE LIMIT OF THE SITE DISTURBED DURING CONSTRUCTION SHALL BE RESTORED TO ORIGINAL CONDITION OR BETTER TO THE SATISFACTION OF THE AUTHORITY HAVING JURISDICTION AT THE CONTRACTOR'S EXPENSE.
  8. RELOCATION OF EXISTING SERVICES AND/OR UTILITIES SHALL BE AS SHOWN ON THE DRAWINGS OR AS DIRECTED BY THE ENGINEER AT THE EXPENSE OF THE CONTRACTOR.
  9. ALL WORK SHALL BE COMPLETED IN ACCORDANCE WITH THE "OCCUPATIONAL HEALTH AND SAFETY ACT AND REGULATIONS FOR CONSTRUCTION PROJECTS". THE GENERAL CONTRACTOR SHALL BE DEEMED TO BE THE CONSTRUCTOR AS DEFINED IN THE ACT.
  10. ALL CONSTRUCTION SIGNAGE MUST CONFORM TO THE M.T.O. MANUAL OF UNIFORM TRAFFIC CONTROL DEVICES (LATEST AMENDMENT).
  11. ALL DIMENSIONS ARE IN METERS UNLESS OTHERWISE SPECIFIED.
  12. THE SUPPORT OF ALL UTILITIES SHALL BE IN ACCORDANCE WITH THE REQUIREMENTS OF THE AUTHORITY HAVING JURISDICTION.
  13. THE CONTRACTOR WILL BE RESPONSIBLE FOR ADDITIONAL BEDDING OR ADDITIONAL STRENGTH PIPE IF THE MAXIMUM TRENCH WIDTH, AS SPECIFIED BY OPSD, IS EXCEEDED.
  14. ALL NECESSARY CLEARING AND GRUBBING SHALL BE COMPLETED BY THE CONTRACTOR. REVIEW WITH THE CITY OF OTTAWA PRIOR TO TREE CUTTING.
  15. REFER TO GEOTECHNICAL INVESTIGATION PREPARED BY PATERSON GROUP, DATED SEPT 2023.
  16. THE CONTRACTOR IS RESPONSIBLE FOR AND SHALL PROVIDE FOR DEWATERING, SUPPORT AND PROTECTION OF EXCAVATIONS AND TRENCHING AS WELL AS RELEASE OF ANY PUMPED GROUNDWATER IN A CONTROLLED AND APPROVED MANNER.
  17. DO NOT CONSTRUCT USING DRAWINGS THAT ARE NOT MARKED "ISSUED FOR CONSTRUCTION".
  18. CONTRACTOR IS RESPONSIBLE FOR ALL LAYOUT FOR CONSTRUCTION PURPOSES.
  19. THE CONTRACTOR SHALL BE RESPONSIBLE TO MANAGE EXCESS SOIL IN ACCORDANCE WITH ONTARIO REGULATION 406/19.

- STORM SEWERS:**
1. ALL REINFORCED CONCRETE STORM SEWER PIPE SHALL BE IN ACCORDANCE WITH CSA A257.2 (LATEST AMENDMENT). ALL NON-REINFORCED CONCRETE STORM SEWER PIPE SHALL BE IN ACCORDANCE WITH CSA A257.1 (LATEST AMENDMENT). PIPE SHALL BE JOINTED WITH STD. RUBBER GASKETS AS PER CSA A257.3 (LATEST AMENDMENT).
  2. ALL PVC STORM SEWERS ARE TO BE SDR 35 APPROVED PER C.S.A. B182.2 OR LATEST AMENDMENT, UNLESS OTHERWISE SPECIFIED.
  3. ALL STORM SEWER TRENCH AND BEDDING SHALL BE IN ACCORDANCE WITH CITY OF OTTAWA STD. S6 AND S7 CLASS 'B' UNLESS OTHERWISE SPECIFIED. BEDDING AND COVER MATERIAL SHALL BE SPECIFIED BY PROJECT GEOTECHNICAL ENGINEER.
  4. CONNECTION TO EXISTING STORM SEWER SHALL BE DONE WITH APPROVED SETTLEMENT CONTROL JOINT PER OTTAWA STD. S11.
  5. STORM MANHOLE FRAME AND COVERS SHALL BE AS PER CITY OF OTTAWA STD. S24.1. CB FRAME AND COVER PER OPSD 400.030.
  6. STORM SEWER MANHOLES SERVING SEWERS LESS THAN 900mm SHALL BE CONSTRUCTED WITH A 300mm SUMP. FOR STORM SEWERS 900mm AND OVER USE BENCHING IN ACCORDANCE WITH OPSD 701.021.
  7. THE STORM SEWER CLASSES HAVE BEEN DESIGNED BASED ON BEDDING CONDITIONS SPECIFIED ABOVE. WHERE THE SPECIFIED TRENCH WIDTH IS EXCEEDED, THE CONTRACTOR SHALL BE REQUIRED TO PROVIDE ADDITIONAL BEDDING, A DIFFERENT TYPE OF BEDDING OR A HIGHER PIPE STRENGTH AT HIS OWN EXPENSE AND SHALL ALSO BE RESPONSIBLE FOR EXTRA TEMPORARY AND/OR PERMANENT REPAIRS MADE NECESSARY BY THE WIDENED TRENCH.
  8. ALL STORM MANHOLES SHALL BE 1000mm DIAMETER AS PER OPSD 701.010 UNLESS OTHERWISE NOTED.
  9. ALL CATCH BASINS SHALL BE 600mm X 600mm AS PER OPSD 705.010 UNLESS OTHERWISE NOTED.
  10. CB AND BUILDING SERVICE LATERALS CONNECTING DIRECTLY TO A SEWER SHALL BE RUN AT 2.0% FOR 1m BEFORE VERTICAL BEND TO INTO SEWER.
  11. SEWERS WITH LESS THAN 2m COVER SHALL BE INSULATED PER CITY OF OTTAWA STD. S35.
  12. HIDE STORM CULVERT TO BE INSTALLED PER OTTAWA STD. S26., MINIMUM 300mm COVER.
  13. PROVIDE FROST TAPER TO CULVERT PER OPSD 903.030.

- SANITARY SEWERS:**
1. ALL SANITARY SEWERS SHALL BE PVC SDR 35, IN ACCORDANCE WITH CITY OF OTTAWA STANDARDS.
  2. SANITARY SEWER TRENCH AND BEDDING SHALL BE AS PER CITY OF OTTAWA STD. S6 AND S7, CLASS 'B' BEDDING UNLESS OTHERWISE NOTED.
  3. SANITARY MANHOLE FRAME AND COVERS SHALL BE WATERTIGHT AS PER CITY OF OTTAWA STD. S24.
  4. SANITARY SEWER MANHOLES SHALL BE BENCHING AS PER OPSD 701.021.
  5. SANITARY PRE-CAST MANHOLE SHALL BE CONSTRUCTED WITH A HIGHER PERCENTAGE OF SILICA FUME IN THE CONCRETE TO MAKE IT MORE DENSE AND LESS SUSCEPTIBLE TO CORROSION OR PINHOLE LEAKS.
  6. CONTRACTOR SHALL PERFORM TESTING, IN THE PRESENCE OF THE CONSULTANT, FOR SANITARY SEWERS IN ACCORDANCE WITH OPSD 410 AND OPSD 407. CONTRACTOR SHALL PERFORM VIDEO INSPECTION OF ALL STORM AND SANITARY SEWERS. A COPY OF THE VIDEO AND INSPECTION REPORT SHALL BE SUBMITTED TO THE ENGINEER FOR REVIEW.
  7. SEWERS AND LATERALS WITH LESS THAN 2m COVER SHALL BE INSULATED PER CITY OF OTTAWA STD. S35.

- WATER SUPPLY:**
1. ALL PVC WATERMANS SHALL BE EQUAL TO MWMA C-300 CLASS 150, SDR 18, OR APPROVED EQUAL.
  2. WATERMAIN TRENCH AND BEDDING SHALL BE IN ACCORDANCE WITH CITY OF OTTAWA STANDARD W17, UNLESS OTHERWISE SPECIFIED. BEDDING AND COVER MATERIAL SHALL BE SPECIFIED BY PROJECT GEOTECHNICAL ENGINEER.
  3. ALL PVC WATERMANS SHALL BE INSTALLED WITH A 10 GAUGE STRANDED COPPER TWU OR RWU TRACER WIRE IN ACCORDANCE WITH CITY OF OTTAWA STD. W36.
  4. CATHODIC PROTECTION IS REQUIRED ON ALL METALLIC FITTINGS AS PER CITY OF OTTAWA STD. W40 AND W42.
  5. CONTRACTOR TO SUPPLY HYDRANT EXTENSION TO ADJUST THE LENGTH OF HYDRANT BARREL IF REQUIRED.
  6. FIRE HYDRANTS SHALL BE INSTALLED AS PER CITY OF OTTAWA STD. W19, AND LOCATED AS PER CITY STD. W18.
  7. VALVE IN BOXES SHALL BE INSTALLED AS PER CITY OF OTTAWA STD. W24.
  8. THRUST BLOCKING OF WATERMAIN TO BE INSTALLED AS PER CITY OF OTTAWA STD. W25.3 AND W25.4.
  9. THE CONTRACTOR SHALL PROVIDE ALL TEMPORARY CAPS, PLUGS AND BLOW-OFFS AND NOZZLES REQUIRED FOR TESTING AND DISINFECTION OF THE WATERMAIN.
  10. INSULATION FOR WATERMAIN CROSSING OVER AND BELOW SEWER SHALL BE IN ACCORDANCE WITH CITY OF OTTAWA STD. W25.2 AND W25, RESPECTIVELY, WHERE WATERMAIN COVER IS LESS THAN 2.4m.
  11. AS PER CITY GUIDELINE, THE MINIMUM VERTICAL CLEARANCE BETWEEN WATERMAIN AND SEWER / UTILITY IS 0.25m FOR CROSSING OVER THE SEWER, AS PER CITY STD. W25.2. FOR CROSSING UNDER SEWER, ADEQUATE STRUCTURAL SUPPORT FOR THE SEWERS IS REQUIRED TO PREVENT EXCESSIVE DEFLECTION OF JOINTS AND SETTLING. THE LENGTH OF WATER PIPE SHALL BE CENTERED AT THE POINT OF CROSSING SO THAT THE JOINTS WILL BE EQUIDISTANT AND AS FAR AS POSSIBLE FROM THE SEWER AS PER CITY STD. W25.
  12. SWABBING, DISINFECTION, AND HYDROSTATIC TESTING TO BE CONDUCTED AS PER CITY OF OTTAWA STANDARDS IN THE PRESENCE OF A CITY INSPECTOR AND/OR CONSULTANT.

- ROADWORK SPECIFICATIONS:**
1. CONCRETE CURB SHALL BE IN ACCORDANCE WITH CITY OF OTTAWA STD. SC1.1 (BARRIER CURB). PROVISION SHALL BE MADE FOR CURB DEPRESSIONS AT SIDEWALKS AND DRIVEWAYS.
  2. ALL BARRIER CURB TO BE 150mm ABOVE FINISHED ASPHALT GRADE UNLESS OTHERWISE NOTED.
  3. MONOLITHIC CURB AND SIDEWALK SHALL BE IN ACCORDANCE WITH CITY OF OTTAWA STD. SC2.
  4. GRANULAR "A" SHALL BE PLACED TO A MINIMUM THICKNESS OF 300mm AROUND ALL STRUCTURES WITHIN PAVEMENT AREA.
  5. ASPHALT WEAR COURSE SHALL NOT BE PLACED UNTIL THE VIDEO INSPECTION OF SEWERS & NECESSARY REPAIRS HAVE BEEN CARRIED OUT TO THE SATISFACTION OF THE ENGINEER.
  6. SUB-EXCAVATE SOFT AREAS AND FILL WITH GRANULAR 'B' COMPACTED IN MAXIMUM 300mm LIFTS.
  7. ALL EDGES OF DISTURBED PAVEMENT SHALL BE SAW-CUT TO FORM A NEAT AND STRAIGHT LINE PRIOR TO PLACING NEW ASPHALT.
  8. PAVEMENT DESIGN AS PER GEOTECHNICAL RECOMMENDATIONS. SEE REPORT BY PATERSON GROUP, DATED SEPT 2023.

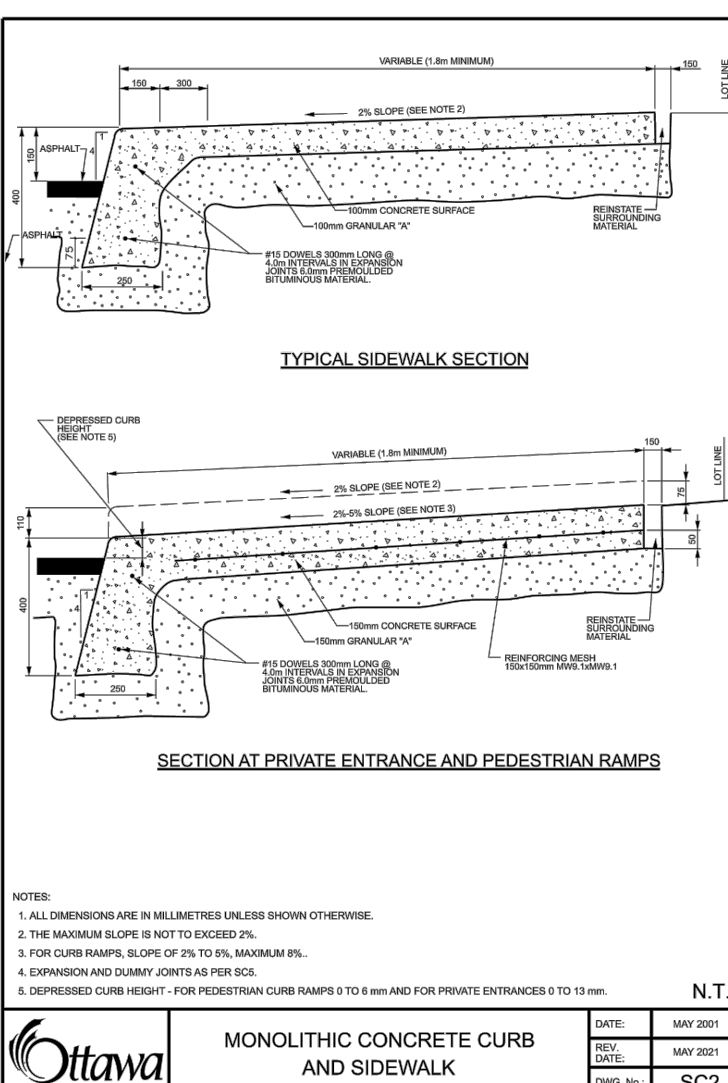
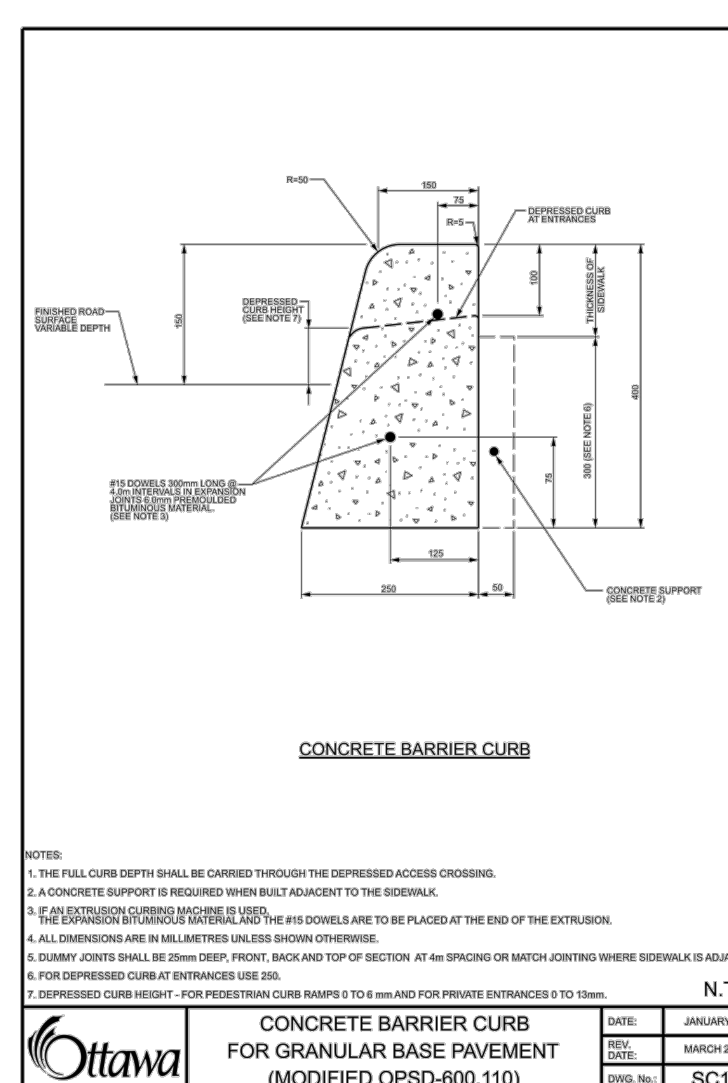
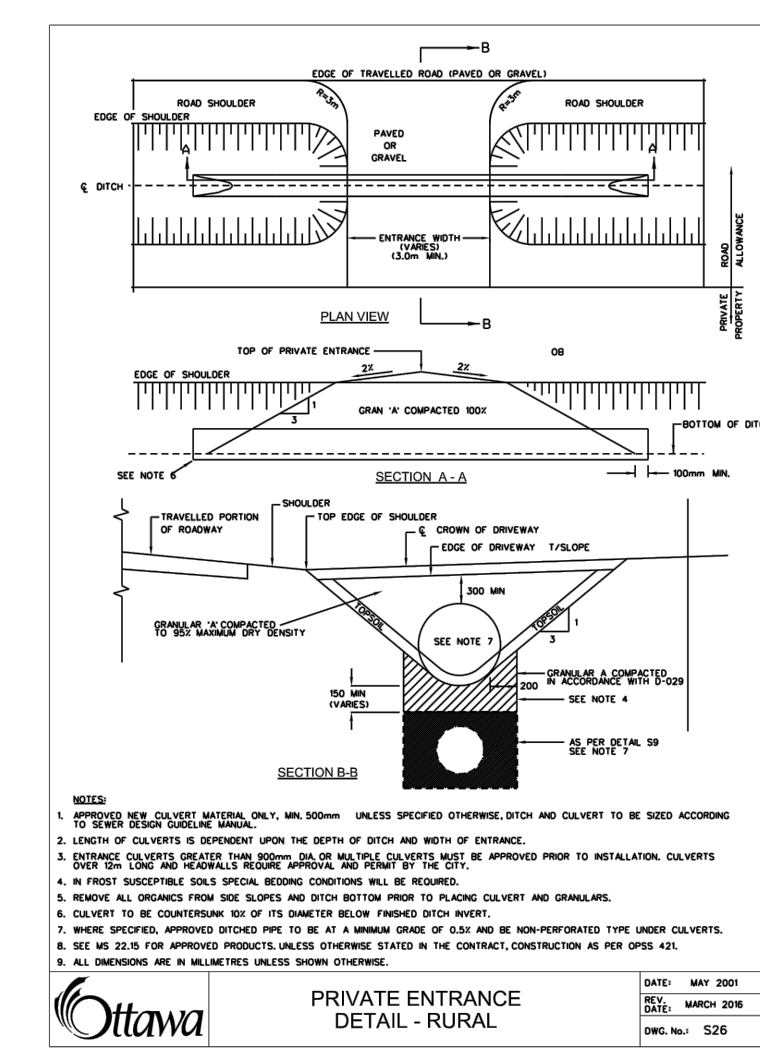
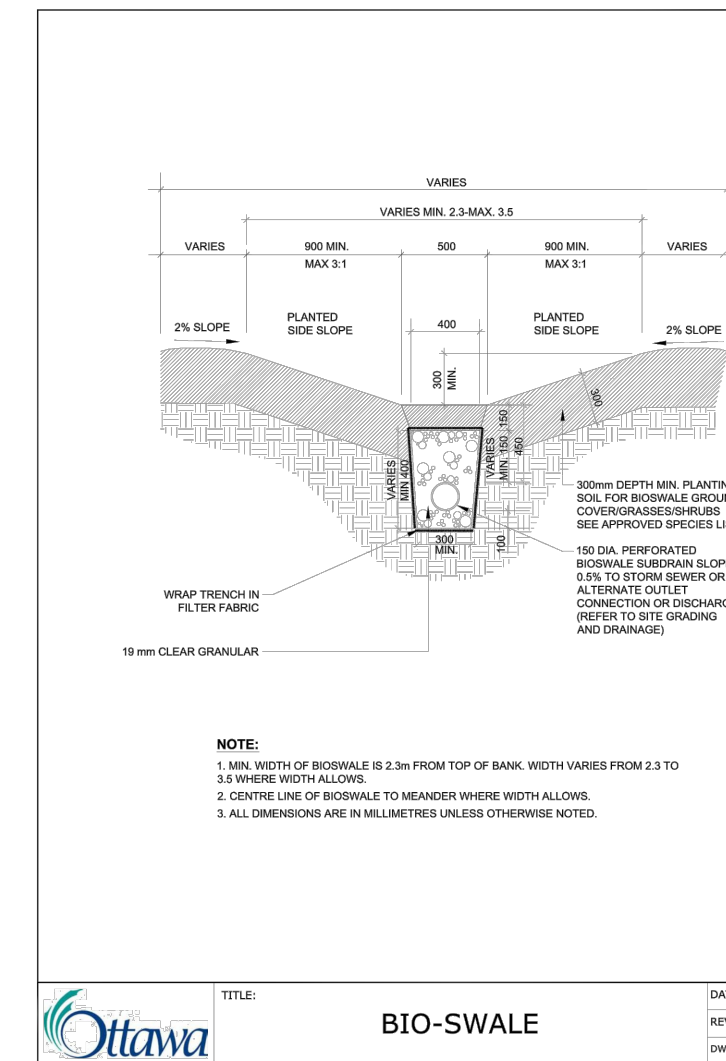
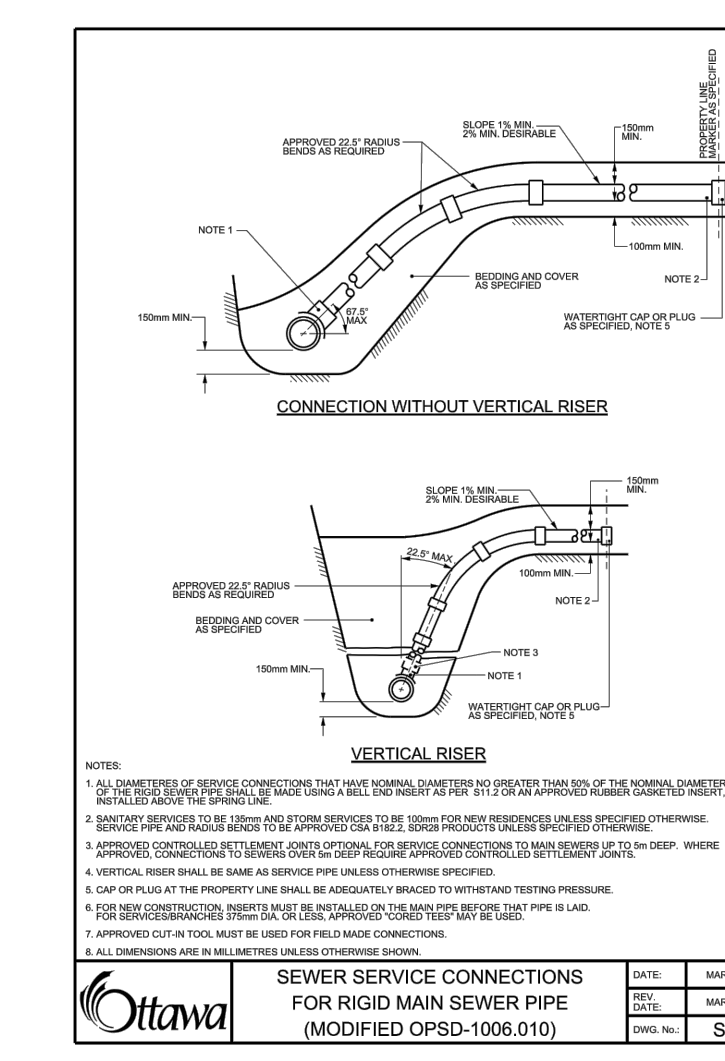
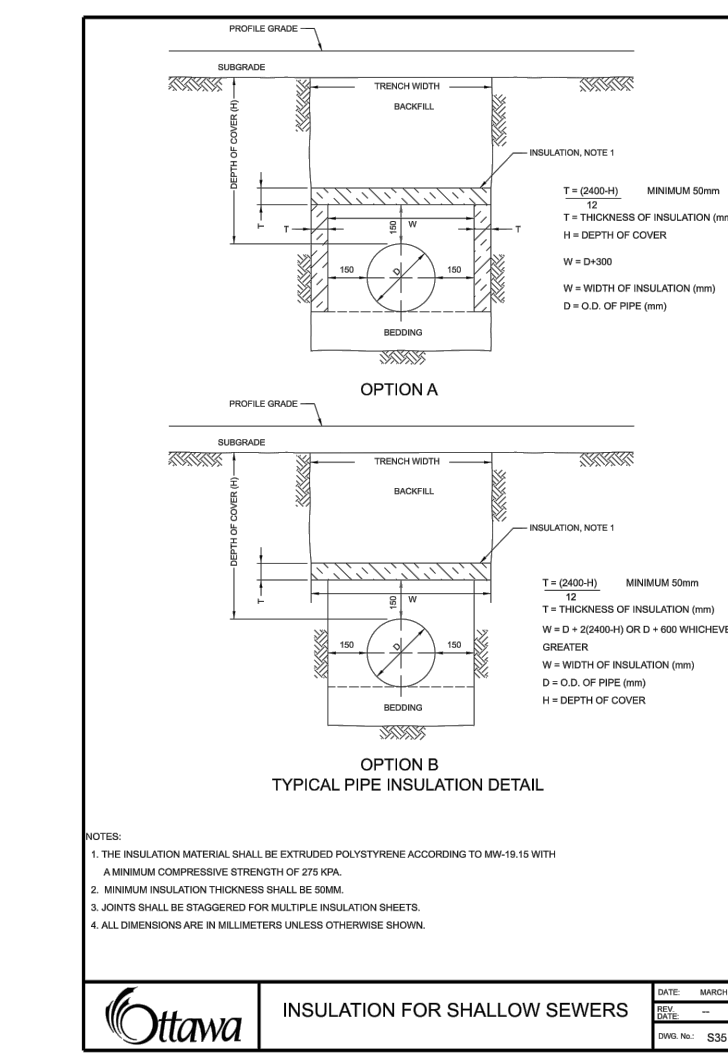
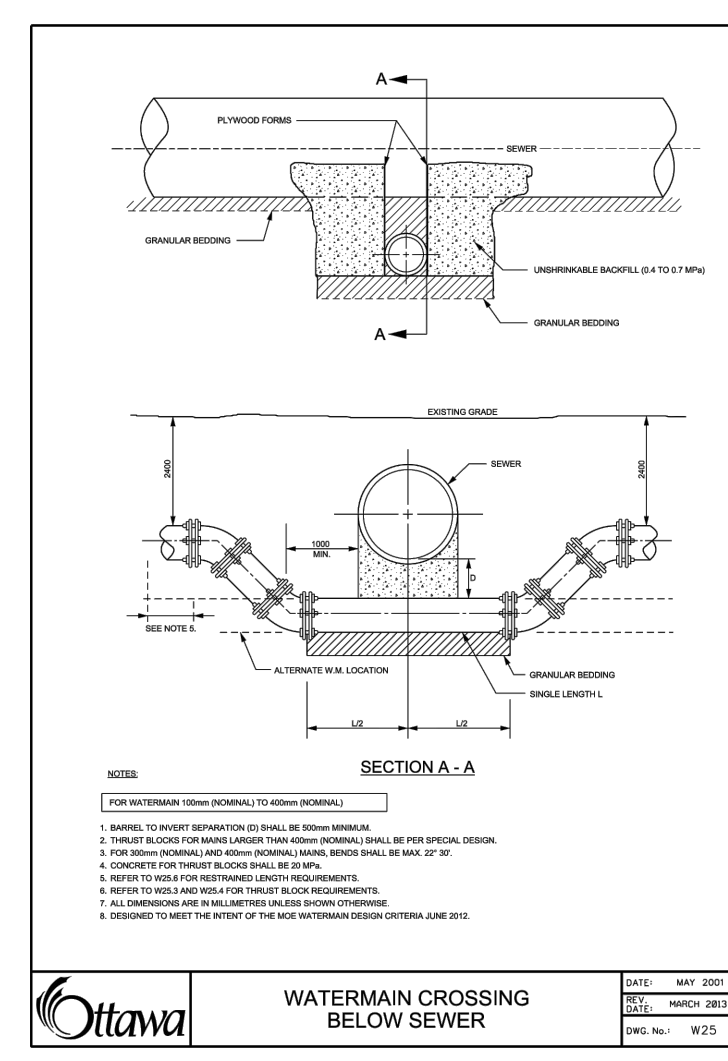
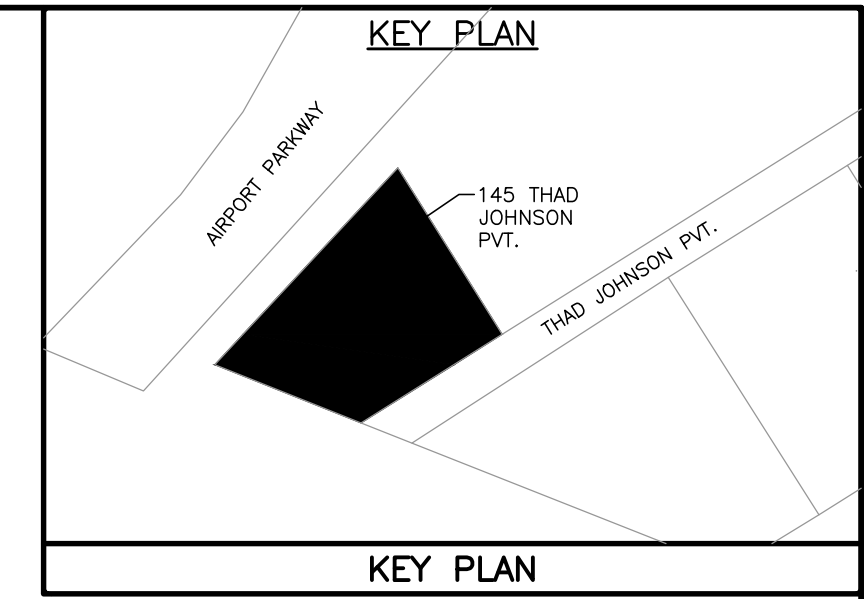
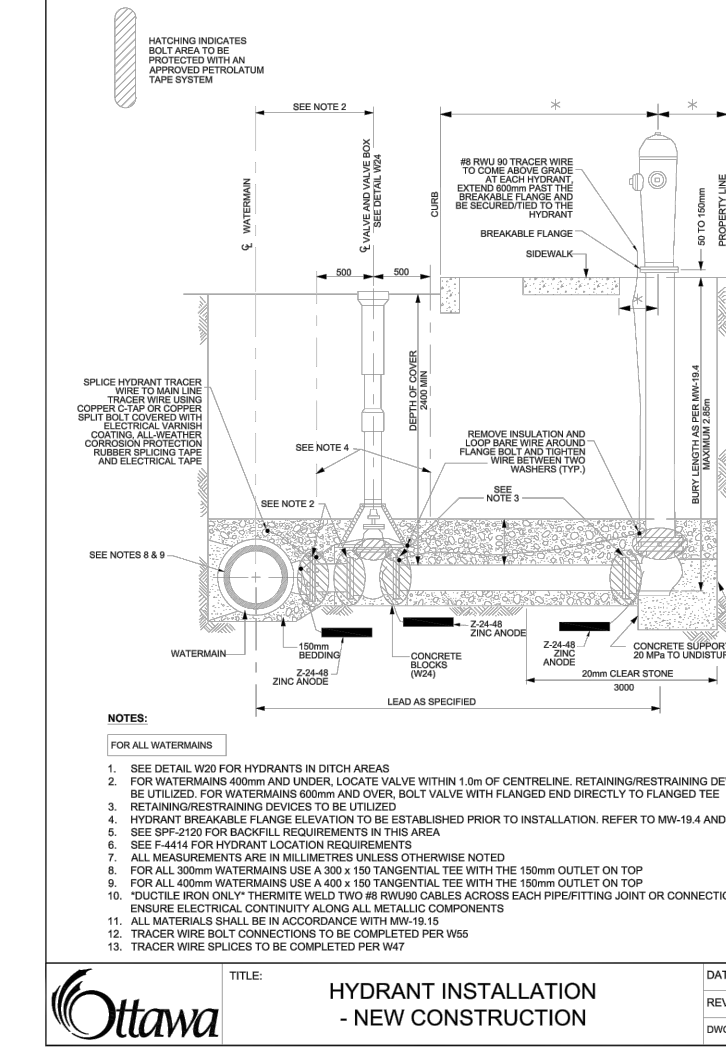
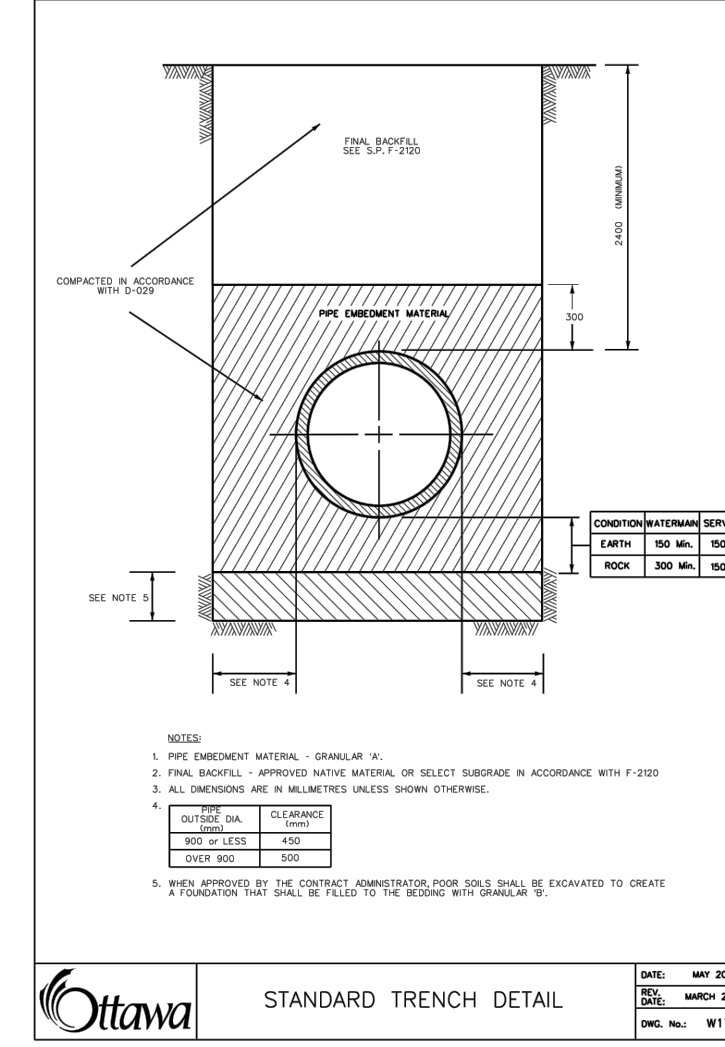
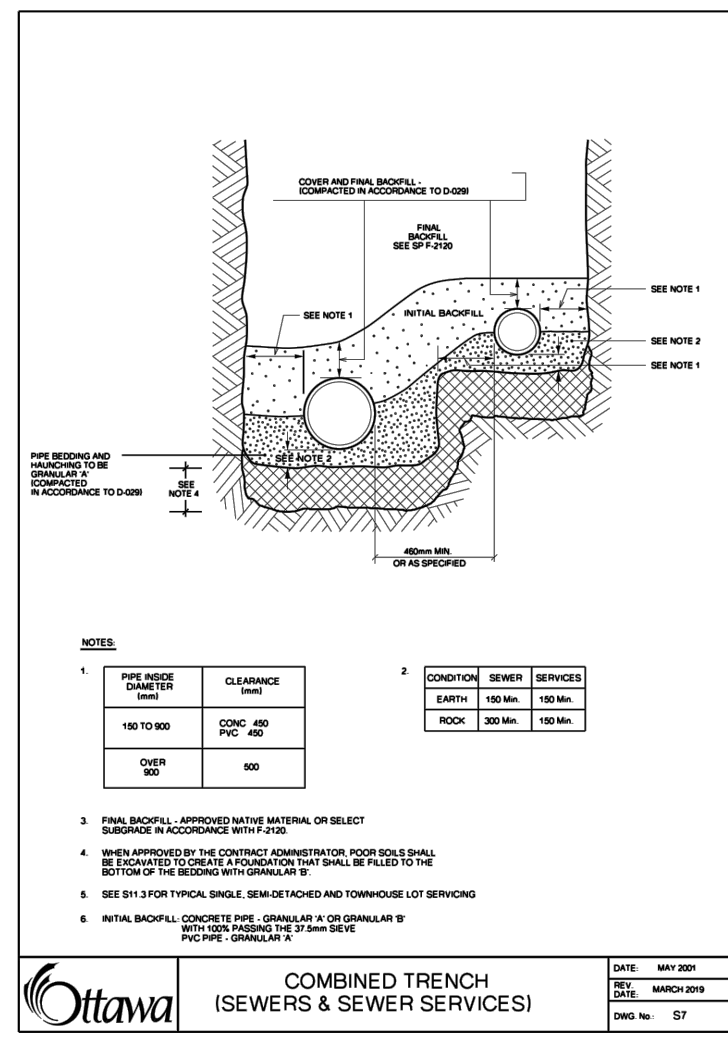
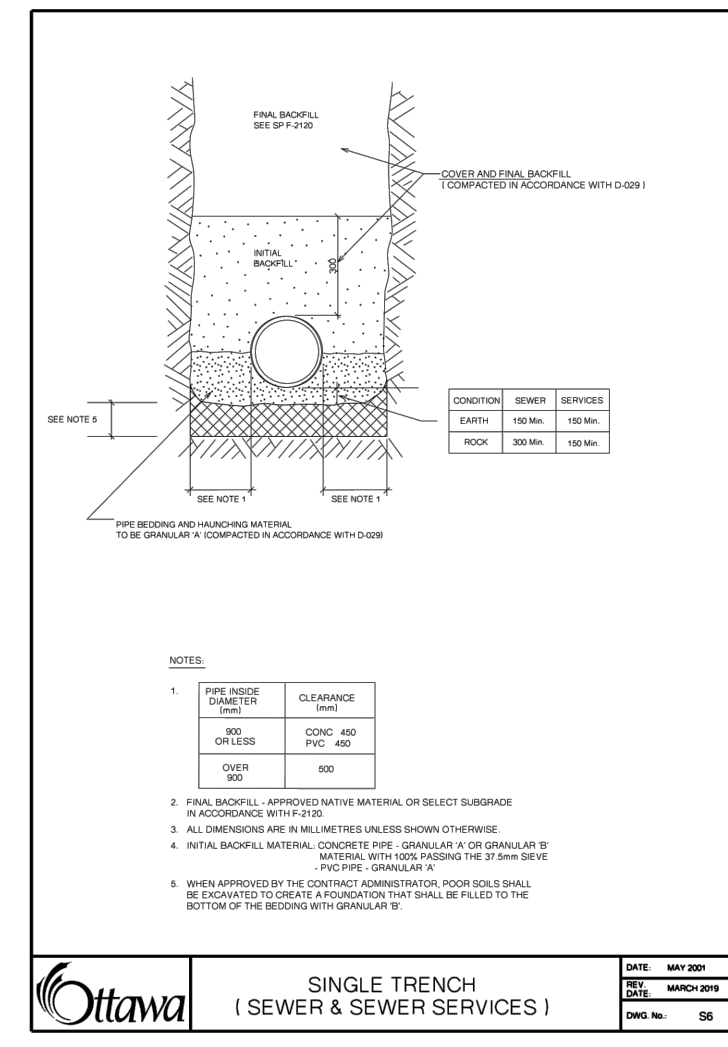

**PRELIMINARY**  
NOT FOR CONSTRUCTION

**NOTES**

THE POSITION OF ALL POLE LINES, CONDUITS, WATERMANS, SEWERS AND OTHER UNDERGROUND AND OVERGROUND UTILITIES AND STRUCTURES IS NOT NECESSARILY SHOWN ON THE CONTRACT DRAWINGS, AND WHERE SHOWN, THE ACCURACY OF THE POSITION OF SUCH UTILITIES AND STRUCTURES IS NOT GUARANTEED. BEFORE STARTING WORK, DETERMINE THE EXACT LOCATION OF ALL SUCH UTILITIES AND STRUCTURES AND ASSUME ALL LIABILITY FOR DAMAGE TO THEM.

PROPERTY BOUNDARIES ARE DERIVED FROM TOPOGRAPHIC SURVEY OF PART OF LOT 11 GORE BETWEEN CONCESSIONS 2 & 3 (RIDEAU FRONT), PART OF THE ROAD ALLOWANCE BETWEEN THE GORE BETWEEN CONCESSIONS 2 & 3 (RIDEAU FRONT) AND CONCESSION 3 (RIDEAU FRONT), GEOGRAPHIC TOWNSHIP OF GLOUCESTER, CITY OF OTTAWA. PREPARED BY FAIRHALL, MOFFATT & WOODLAND LTD. ONTARIO LAND SURVEYORS, REF: A027800. ELEVATIONS ARE REFERRED TO GEODETIC DATUM (CGVD28).

NO.	REVISION DESCRIPTION	DATE	BY
2	REISSUED FOR SITE PLAN	26/02/24	CC
1	ISSUED FOR SITE PLAN	11/01/24	CC

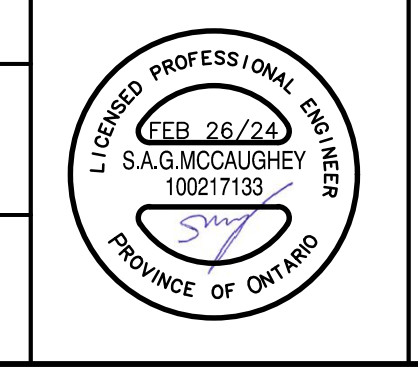

**Robinson Land Development**

350 Palladium Drive  
Ottawa, ON K2V 1A8  
(613) 592-6060 rcil.com

DESIGN	SM
CHECKED	CC
DRAWN	SM
CHECKED	CC
APPROVED	CC

**JENNINGS REAL ESTATE**

145 THAD JOHNSON PRIVATE  
CITY OF OTTAWA

**NOTES AND DETAILS PLAN**

PROJECT No.	23069
SURVEY	FMW
DATED	FEB 2024
DWG. No.	23069-N1

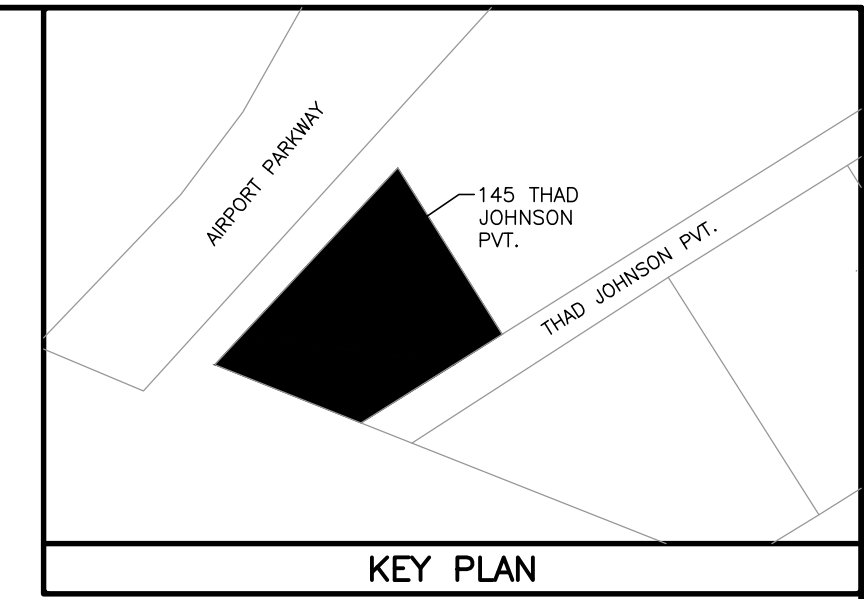
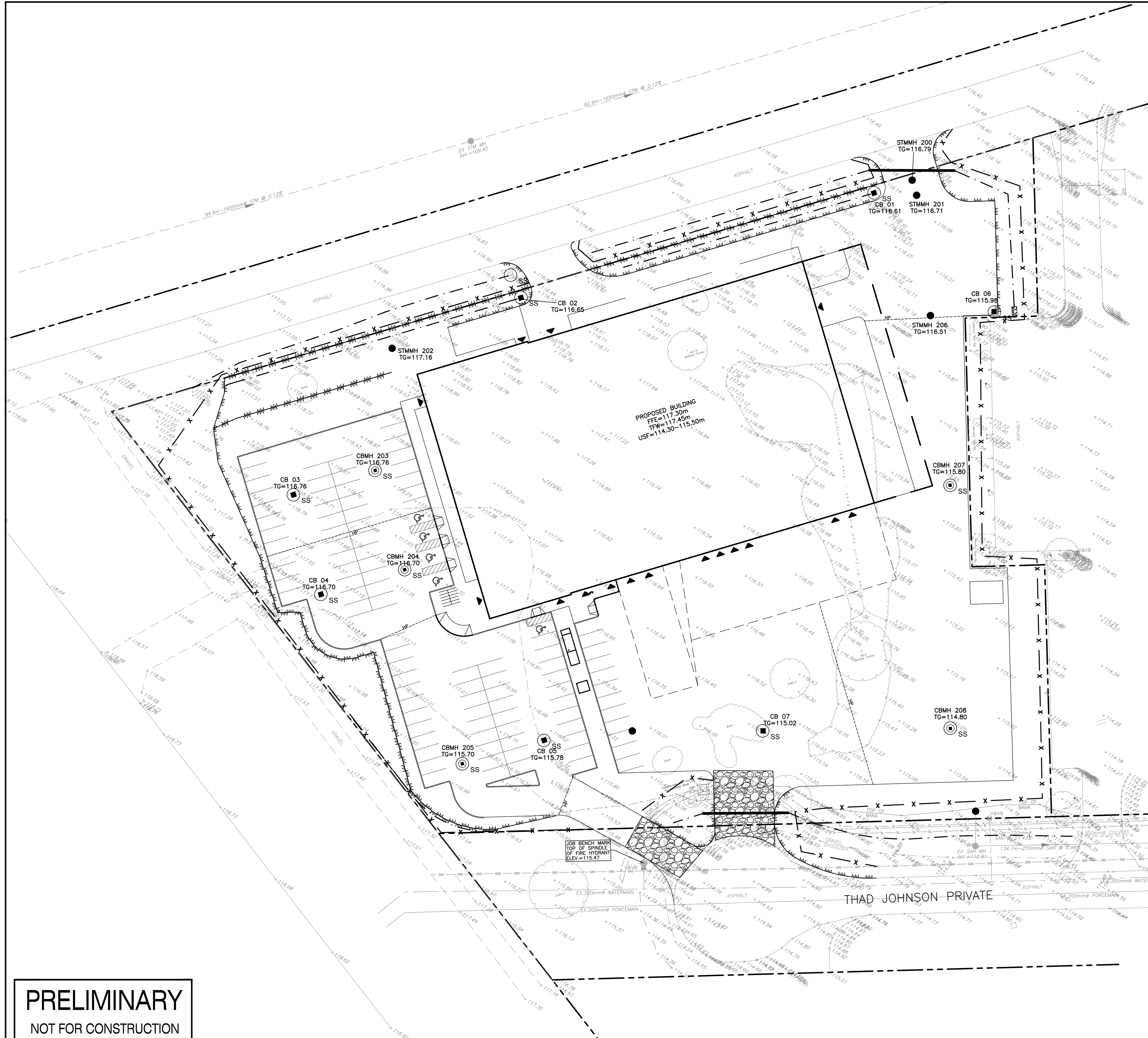

**KEY PLAN**

**LEGEND**

- SITE BOUNDARY
- +104.00 EXISTING ELEVATION
- EXISTING HYDRANT
- ⊕ EXISTING VALVE & VALVE BOX
- EXISTING WATERMAIN
- EXISTING SANITARY SEWER & MANHOLE
- EXISTING STORM SEWER & MANHOLE
- EXISTING CATCH BASIN
- EXISTING DITCH CENTRELINE
- EXISTING GAS LINE
- EXISTING BELL LINE
- EXISTING HYDRO LINE
- EXISTING STREELIGHT LINE
- EXISTING LIGHT STANDARD
- EXISTING FENCE
- EXISTING BOLLARD
- STORM SEWER & MANHOLE
- CATCH BASIN
- SWALE
- ▲ BUILDING ENTRANCE
- SILT FENCE
- SS SILT SACK (OR APPROVED EQUIVALENT)

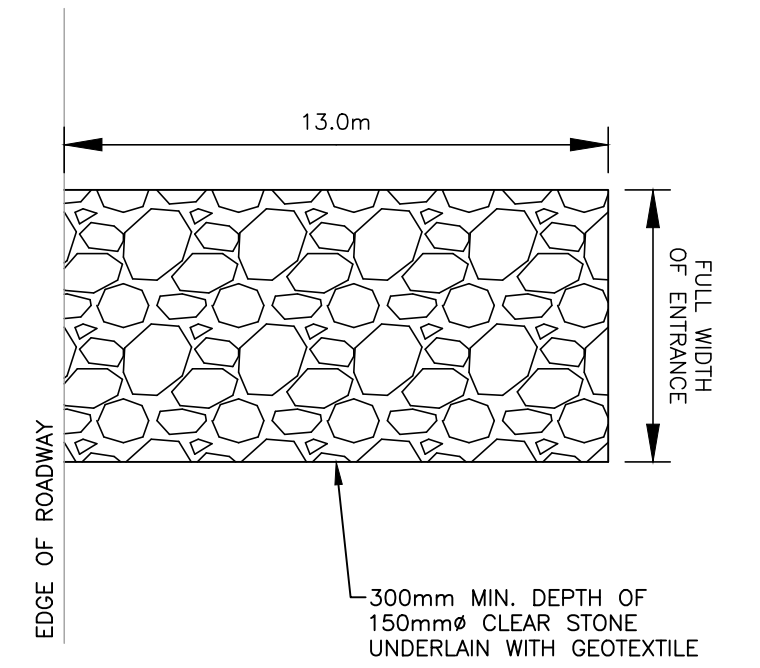
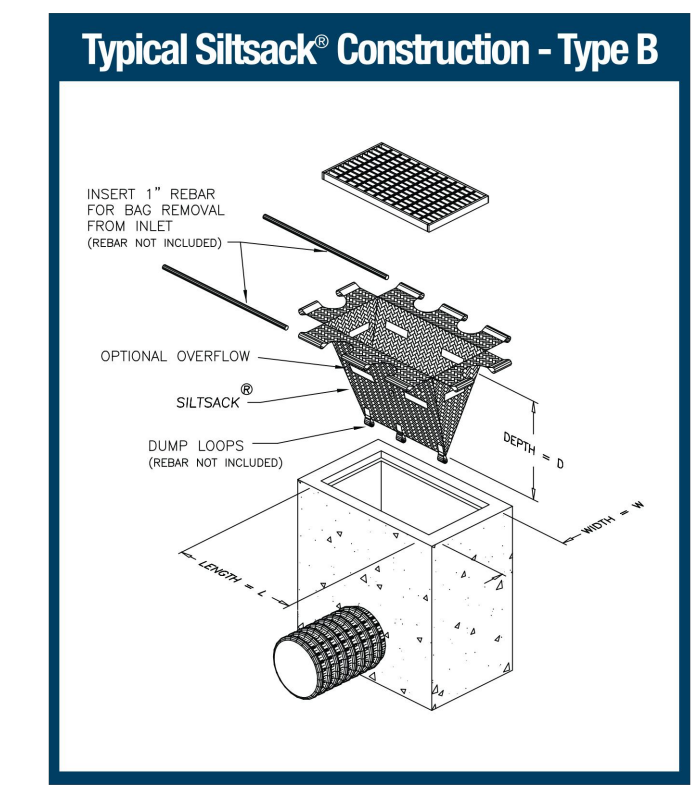

- NOTES:**
- MUD MAT TO BE UNDERLAIN WITH A GEOTEXTILE FABRIC.
  - SEDIMENT SHALL BE CLEANED FROM ROADWAYS AS REQUIRED.
  - STORM INLETS IN CLOSE VICINITY TO MUD MAT SHALL BE PROTECTED WITH INLET CONTROL MEASURES.

- NOTES:**
- THE CONTRACTOR SHALL IMPLEMENT BEST MANAGEMENT PRACTICES TO PROVIDE FOR PROTECTION OF THE AREA DRAINAGE SYSTEM AND THE ULTIMATE RECEIVING WATERCOURSE DURING CONSTRUCTION ACTIVITIES. THE CONTRACTOR ACKNOWLEDGES THAT FAILURE TO IMPLEMENT APPROPRIATE EROSION AND SEDIMENT CONTROL MEASURES MAY BE SUBJECT TO PENALTIES IMPOSED BY ANY APPLICABLE REGULATORY AGENCY.
  - LIMIT THE EXTENT OF EXPOSED SOILS AT ANY GIVEN TIME.
  - EROSION AND SEDIMENT CONTROL MEASURES SHALL BE MAINTAINED UNTIL VEGETATION HAS BEEN RE-ESTABLISHED IN ALL DISTURBED AREAS. RE-VEGETATE DISTURBED AREAS AS SOON AS POSSIBLE.
  - STOCKPILE SOIL AWAY (15 METRES OR GREATER) FROM WATERCOURSES, DRAINAGE FEATURES AND TOP OF STEEP SLOPES.
  - SILT SACKS ARE TO BE PLACED UNDERNEATH THE FRAME AND COVER OF ALL PROPOSED AND EXISTING CATCH BASIN AND OPEN COVER STORM MANHOLES UNTIL CONSTRUCTION IS COMPLETED.
  - A SILT FENCE BARRIER SHALL BE INSTALLED AS PER OPSD 219.110 WHERE INDICATED AND MAINTAINED AS REQUIRED.
  - INSTALL MUD MATS AT ALL CONSTRUCTION ENTRANCES.
  - DURING ACTIVE CONSTRUCTION PERIODS, VISUAL INSPECTIONS SHALL BE UNDERTAKEN ON A WEEKLY BASIS AND AFTER MAJOR STORM EVENTS (>25mm RAIN IN 24 HOUR PERIOD) ON SEDIMENT CONTROL BARRIERS AND ANY DAMAGE REPAIRED IMMEDIATELY.
  - EROSION AND SEDIMENT CONTROL BARRIERS SHALL ALSO BE ASSESSED (AND REPAIRED AS REQUIRED) FOLLOWING SIGNIFICANT SNOWMELT EVENTS.
  - VISUAL INSPECTIONS SHALL ALSO BE UNDERTAKEN IN ANTICIPATION OF LARGE STORM EVENTS (OR A SERIES OF RAINFALL AND/OR SNOWMELT DAYS) THAT COULD POTENTIALLY YIELD SIGNIFICANT RUNOFF VOLUMES.
  - CARE SHALL BE TAKEN TO PREVENT DAMAGE TO EROSION AND SEDIMENT CONTROLS DURING CONSTRUCTION OPERATIONS.
  - IN SOME CASES, BARRIERS MAY BE REMOVED TEMPORARILY TO ACCOMMODATE THE CONSTRUCTION OPERATIONS. THE AFFECTED BARRIERS SHALL BE REINSTITATED IMMEDIATELY AFTER CONSTRUCTION OPERATIONS ARE COMPLETED.
  - EROSION AND SEDIMENT CONTROL MEASURES SHALL BE ADJUSTED AS REQUIRED AS THE SITE BECOMES DEVELOPED.
  - SEDIMENT CONTROL DEVICES SHALL BE CLEANED OF ACCUMULATED SEDIMENTATION AS REQUIRED AND REPLACED AS NECESSARY.
  - DURING THE COURSE OF CONSTRUCTION, IF THE ENGINEER BELIEVES THAT ADDITIONAL PREVENTION METHODS ARE REQUIRED TO CONTROL EROSION AND SEDIMENTATION, THE CONTRACTOR SHALL IMPLEMENT ADDITIONAL MEASURES, AS REQUIRED, TO THE SATISFACTION OF THE ENGINEER.
  - CONSTRUCTION AND MAINTENANCE REQUIREMENTS FOR EROSION AND SEDIMENT CONTROLS ARE TO COMPLY WITH OPSS 805.

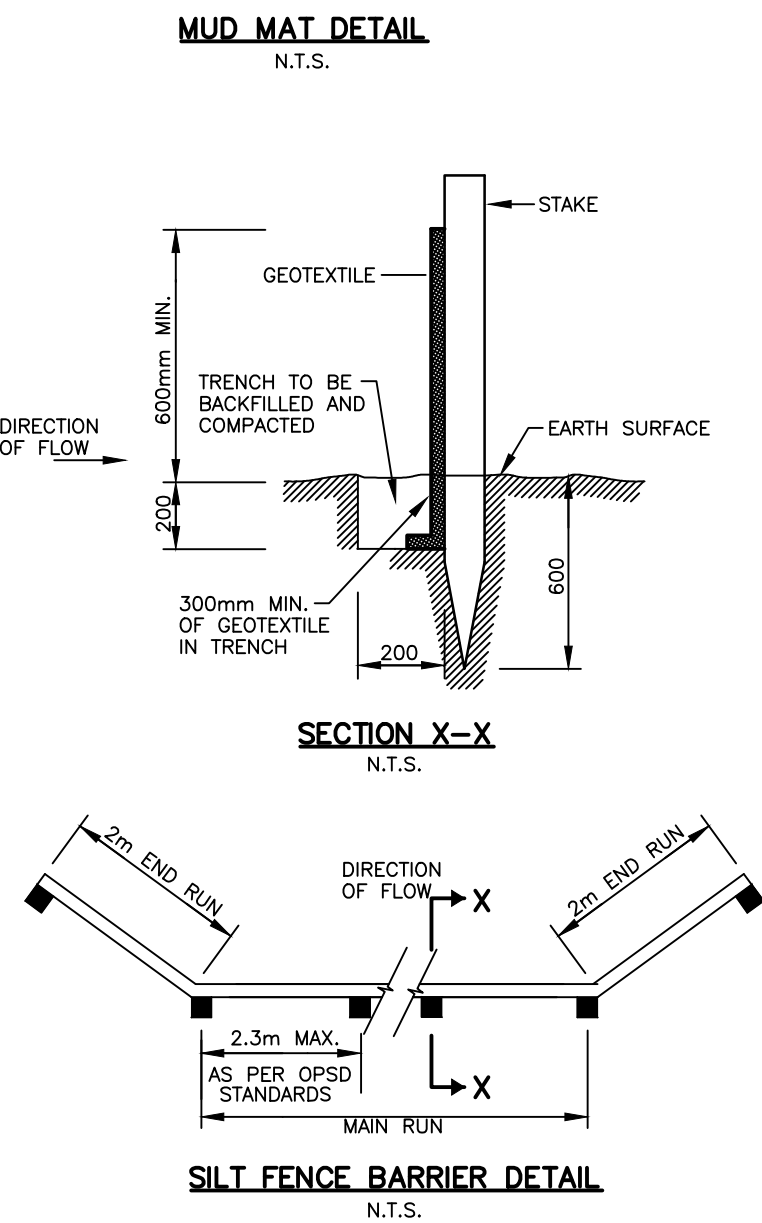

**PRELIMINARY**  
NOT FOR CONSTRUCTION

**NOTES**

THE POSITION OF ALL POLE LINES, CONDUITS, WATERMANS, SEWERS AND OTHER UNDERGROUND AND OVERGROUND UTILITIES AND STRUCTURES IS NOT NECESSARILY SHOWN ON THE CONTRACT DRAWINGS, AND WHERE SHOWN, THE ACCURACY OF THE POSITION OF SUCH UTILITIES AND STRUCTURES IS NOT GUARANTEED. BEFORE STARTING WORK, DETERMINE THE EXACT LOCATION OF ALL SUCH UTILITIES AND STRUCTURES AND ASSUME ALL LIABILITY FOR DAMAGE TO THEM.

PROPERTY BOUNDARIES ARE DERIVED FROM TOPOGRAPHIC SURVEY OF PART OF LOT 11 GORE BETWEEN CONCESSIONS 2 & 3 (RIDEAU FRONT), PART OF THE ROAD ALLOWANCE BETWEEN THE GORE BETWEEN CONCESSIONS 2 & 3 (RIDEAU FRONT) AND CONCESSION 3 (RIDEAU FRONT), GEOGRAPHIC TOWNSHIP OF GLOUCESTER, CITY OF OTTAWA. PREPARED BY FAIRHALL, MOFFATT & WOODLAND LTD. ONTARIO LAND SURVEYORS, REF: AD27800. ELEVATIONS ARE REFERRED TO GEODETIC DATUM (CGVD25).

NO.	REVISION DESCRIPTION	DATE	BY
2	REISSUED FOR SITE PLAN	26/02/24	CC
1	ISSUED FOR SITE PLAN	11/01/24	CC

**SCALE**

0 4m 8m 16m

HORIZONTAL 1:400

**PROFESSIONAL ENGINEER**  
CEB 26/12/22  
S.A. MCCAGHEY  
00217133  
PROVINCE OF ONTARIO

**Robinson**  
Land Development

350 Palladium Drive  
Ottawa, ON K2V 1A8  
(613) 592-6060 rcil.com

DESIGN	SM
CHECKED	CC
DRAWN	SM
CHECKED	CC
APPROVED	CC

JENNINGS REAL ESTATE

145 THAD JOHNSON PRIVATE  
CITY OF OTTAWA

**EROSION AND SEDIMENT CONTROL PLAN**

PROJECT No.	23069
SURVEY	FMW
DATED	FEB 2024
DWG. No.	23069-ESC1

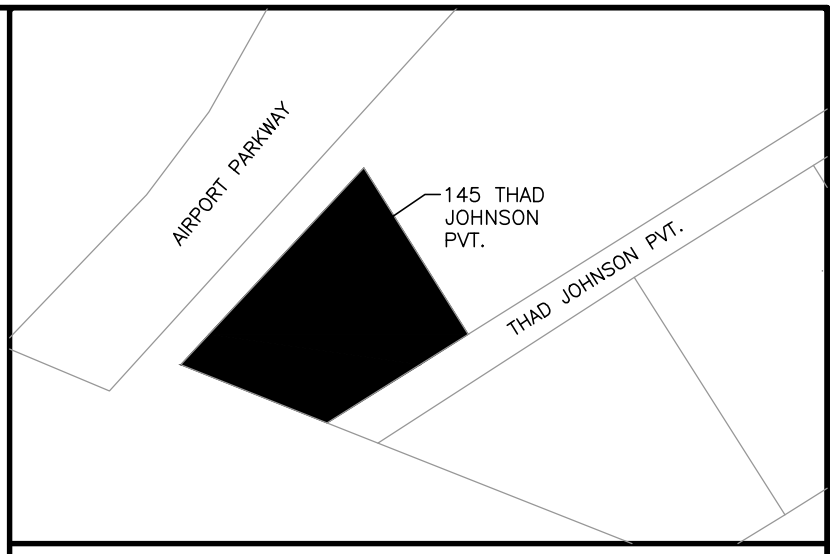
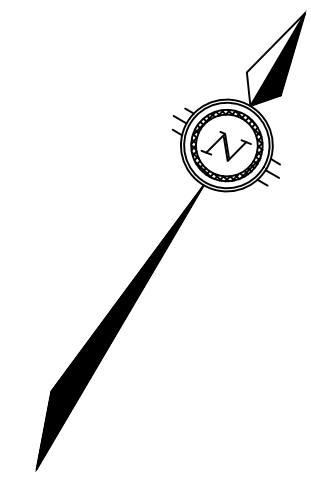
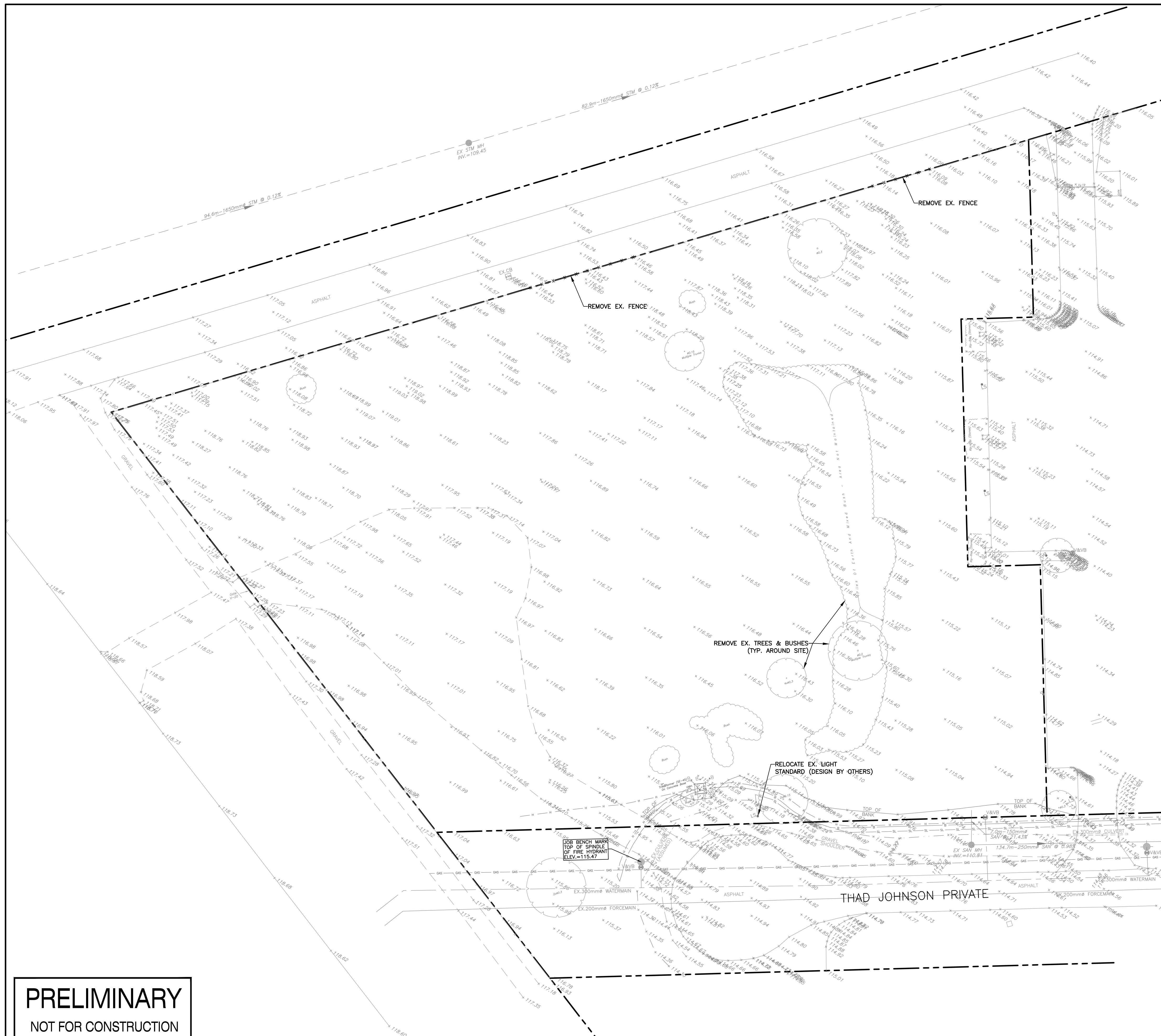

KEY PLAN

LEGEND

- SITE BOUNDARY
- +104.00 EXISTING ELEVATION
- EXISTING HYDRANT
- ⊕ V&VB EXISTING VALVE & VALVE BOX
- EXISTING WATERMAIN
- EXISTING SANITARY SEWER & MANHOLE
- EXISTING STORM SEWER & MANHOLE
- EXISTING CATCH BASIN
- EXISTING DITCH CENTRELINE
- GAS EXISTING GAS LINE
- BELL EXISTING BELL LINE
- HYDRO EXISTING HYDRO LINE
- STREELIGHT EXISTING STREELIGHT LINE
- LS EXISTING LIGHT STANDARD
- X — EXISTING FENCE
- B EXISTING BOLLARD

**PRELIMINARY**  
NOT FOR CONSTRUCTION

**NOTES**  
THE POSITION OF ALL POLE LINES, CONDUITS, WATERMANS, SEWERS AND OTHER UNDERGROUND AND OVERGROUND UTILITIES AND STRUCTURES IS NOT NECESSARILY SHOWN ON THE CONTRACT DRAWINGS, AND WHERE SHOWN, THE ACCURACY OF THE POSITION OF SUCH UTILITIES AND STRUCTURES IS NOT GUARANTEED. BEFORE STARTING WORK, DETERMINE THE EXACT LOCATION OF ALL SUCH UTILITIES AND STRUCTURES AND ASSUME ALL LIABILITY FOR DAMAGE TO THEM.  
PROPERTY BOUNDARIES ARE DERIVED FROM TOPOGRAPHIC SURVEY OF PART OF LOT 11 GORE BETWEEN CONCESSIONS 2 & 3 (RIDEAU FRONT), PART OF THE ROAD ALLOWANCE BETWEEN THE GORE BETWEEN CONCESSIONS 2 & 3 (RIDEAU FRONT) AND CONCESSION 3 (RIDEAU FRONT), GEOGRAPHIC TOWNSHIP OF GLOUCESTER, CITY OF OTTAWA. PREPARED BY FAIRHALL, MOFFATT & WOODLAND LTD. ONTARIO LAND SURVEYORS, REF: AD27800. ELEVATIONS ARE REFERRED TO GEODETIC DATUM (CGVD28).

NO.	REVISION DESCRIPTION	DATE	BY
2	REISSUED FOR SITE PLAN	26/02/24	CC
1	ISSUED FOR SITE PLAN	11/01/24	CC

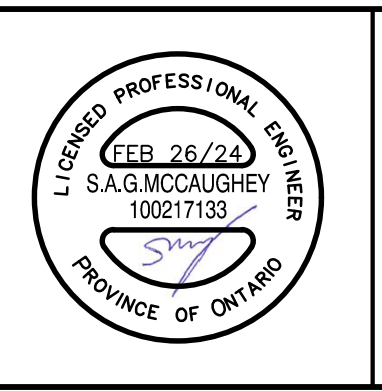
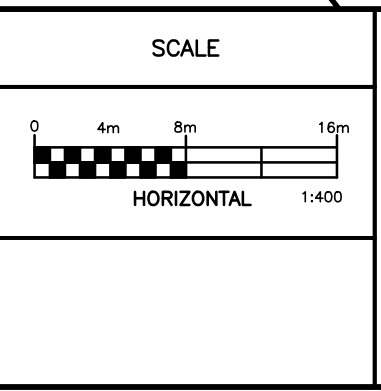

**Robinson Land Development**  
350 Palladium Drive  
Ottawa, ON K2V 1A8  
(613) 592-6060 rcii.com

DESIGN	SM
CHECKED	CC
DRAWN	SM
CHECKED	CC
APPROVED	CC

JENNINGS REAL ESTATE  
145 THAD JOHNSON PRIVATE  
CITY OF OTTAWA

EXISTING CONDITIONS AND  
REMOVALS PLAN

PROJECT No.	23069
SURVEY	FMW
DATED	FEB 2024
DWG. No.	23069-R1

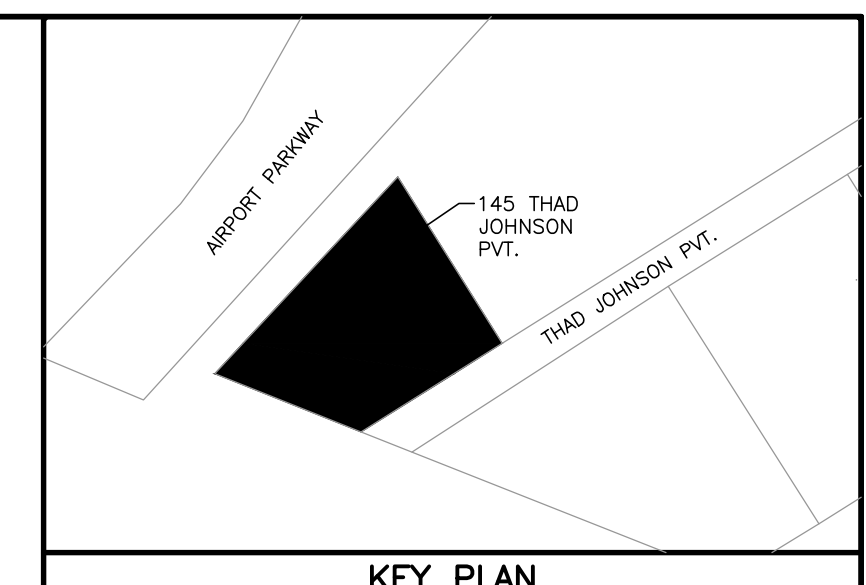
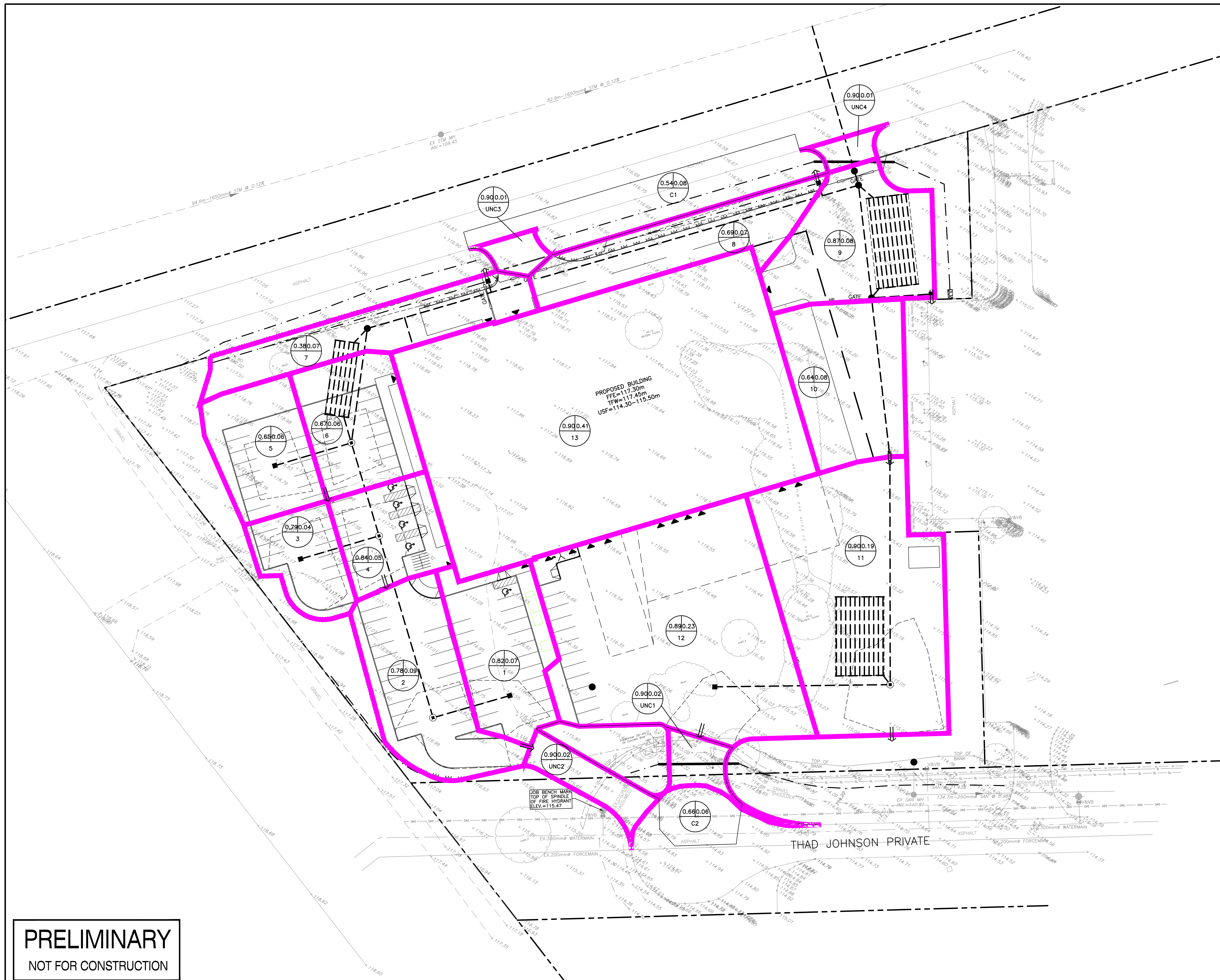

**LEGEND**

- SITE BOUNDARY
- +104.00 EXISTING ELEVATION
- EXISTING HYDRANT
- ⊕ V&VB EXISTING VALVE & VALVE BOX
- EXISTING WATERMAIN
- EXISTING SANITARY SEWER & MANHOLE
- EXISTING STORM SEWER & MANHOLE
- EXISTING CATCH BASIN
- EXISTING DITCH CENTRELINE
- GAS EXISTING GAS LINE
- BELL EXISTING BELL LINE
- HYDRO EXISTING HYDRO LINE
- STREELIGHT EXISTING STREELIGHT LINE
- LS EXISTING LIGHT STANDARD
- X — EXISTING FENCE
- B EXISTING BOLLARD
- CATCH BASIN
- STORM SEWER & MANHOLE
- STORM DRAINAGE AREA BOUNDARY
- STORM DRAINAGE AREA BOUNDARY (CULVERT)
- ⇒ MAJOR OVERLAND FLOW ROUTE
- 100-YEAR PONDING LIMIT

**RUNOFF COEFFICIENT**

0.50/0.28 ← AREA (ha)

STM1

↑ DRAINAGE AREA ID

**PRELIMINARY**  
NOT FOR CONSTRUCTION

**NOTES**  
THE POSITION OF ALL POLE LINES, CONDUITS, WATERMANS, SEWERS AND OTHER UNDERGROUND AND OVERGROUND UTILITIES AND STRUCTURES IS NOT NECESSARILY SHOWN ON THE CONTRACT DRAWINGS, AND WHERE SHOWN, THE ACCURACY OF THE POSITION OF SUCH UTILITIES AND STRUCTURES IS NOT GUARANTEED. BEFORE STARTING WORK, DETERMINE THE EXACT LOCATION OF ALL SUCH UTILITIES AND STRUCTURES AND ASSUME ALL LIABILITY FOR DAMAGE TO THEM.

PROPERTY BOUNDARIES ARE DERIVED FROM TOPOGRAPHIC SURVEY OF PART OF LOT 11 GORE BETWEEN CONCESSIONS 2 & 3 (RIDEAU FRONT), PART OF THE ROAD ALLOWANCE BETWEEN THE GORE BETWEEN CONCESSIONS 2 & 3 (RIDEAU FRONT) AND CONCESSION 3 (RIDEAU FRONT), GEOGRAPHIC TOWNSHIP OF GLOUCESTER, CITY OF OTTAWA. PREPARED BY FAIRHALL, MOFFATT & WOODLAND LTD. ONTARIO LAND SURVEYORS, REF: AD27800. ELEVATIONS ARE REFERRED TO GEODETIC DATUM (CGVD28).

NO.	REVISION DESCRIPTION	DATE	BY
2	REISSUED FOR SITE PLAN	26/02/24	CC
1	ISSUED FOR SITE PLAN	11/01/24	CC

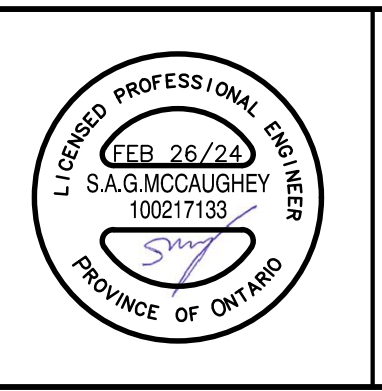
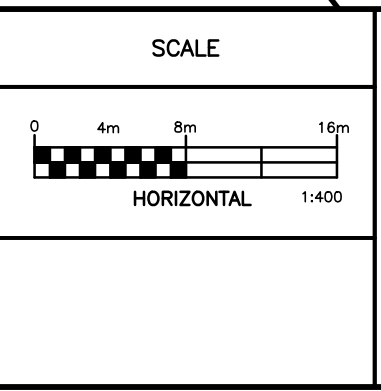

**Robinson Land Development**  
350 Palladium Drive  
Ottawa, ON K2V 1A8  
(613) 592-6060 rcii.com

DESIGN	SM
CHECKED	CC
DRAWN	SM
CHECKED	CC
APPROVED	CC

JENNINGS REAL ESTATE  
145 THAD JOHNSON PRIVATE  
CITY OF OTTAWA

**STORM AREA DRAINAGE PLAN**

PROJECT No.	23069
SURVEY	FMW
DATED	FEB 2024
DWG. No.	23069-STM1