

# STRATZER

## TECHNICAL NOTE

---

**GWL Realty Advisor**  
**170 Slater, Ottawa, ON**  
**Waste Management Plan**  
June 08, 2023

1. Initial Information .....	2
2. Waste generation evaluation .....	7
3. Indoor Storage Scenarios.....	8
4. Collection area requirements (538 units) .....	12
5. Recommendation.....	15
6. Container handling .....	16
7. Eligible containers .....	18
8. SectionS from the City of Ottawa Solid Waste Collection Design Guidelines for Multi-Unit Residential Development.....	23

# 1. INITIAL INFORMATION

## 1.1 PROJECT SUMMARY

The 170 Slater project, in Ottawa, consists of two new residential buildings and a podium. The North Tower has 24 floors, while the South Tower has 25 floors. The podium, connecting the two towers, has 7 floors. Furthermore, underground parking levels will be present.

The North Tower will accommodate 173 residential units and a 467.5 m<sup>2</sup> retail, while the South Tower contains 184 units and a 376.4 m<sup>2</sup> retail. The podium will have 181 residential units. The waste management for the residential units will be done separately between the two buildings, except for the collection, which will take place for both buildings at the same location, in the loading bay located between the two towers and under the podium. Waste from retail will be managed separately from the residential waste.

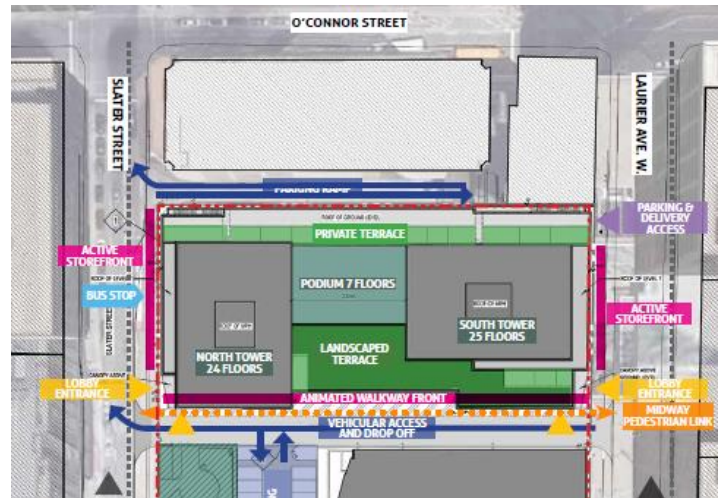

The size of the different units and the estimated number of occupants for each one allows determining the expected number of residents. These data are presented in Table 1 below.

**Table 1. Distribution of the residents of 170 Slater**

Unit Type	Number of Units	Average number of residents per unit (assumptions)	Total number of residents per unit type
<b>North Tower</b>	<b>173</b>	<b>2.1</b>	<b>364</b>
1 Bedroom	61	1.5	92
1 Bedroom + Den	22	1.5	33
2 Bedroom	76	2.5	190
3 Bedroom	14	3.5	49
<b>South Tower</b>	<b>184</b>	<b>2.1</b>	<b>384</b>
1 Bedroom	66	1.5	99
1 Bedroom + Den	24	1.5	36
2 Bedroom	80	2.5	200
3 Bedroom	14	3.5	49
<b>Podium</b>	<b>181</b>	<b>1.6</b>	<b>296</b>
Studio	23	1	23

Unit Type	Number of Units	Average number of residents per unit (assumptions)	Total number of residents per unit type
1 Bedroom	28	1.5	42
1 Bedroom + Den	95	1.5	143
2 Bedroom	34	2.5	85
3 Bedroom	1	3.5	4
<b>TOTAL (residential)</b>	<b>538</b>	<b>1.9</b>	<b>1,044</b>
<b>North Tower – commercial</b>	<b>467.5 m<sup>2</sup></b>	<b>N/A</b>	<b>N/A</b>
<b>South Tower – commercial</b>	<b>376.4 m<sup>2</sup></b>	<b>N/A</b>	<b>N/A</b>
<b>TOTAL (commercial)</b>	<b>843.9 m<sup>2</sup></b>	<b>N/A</b>	<b>N/A</b>

## 1.2 CHARACTERISTICS OF THE PROJECT’S WASTE MANAGEMENT

- Both the North Tower and the South Tower have access to two chutes, one with a bi-sorter unit for garbage and organics and the other for recyclables (containers). The Podium has access to chutes from both towers;
- The chutes from each tower lead to a waste storage room on the ground floor of each tower;
- Fibres will be transported by the residents to the waste storage room on the ground floor;
- The retail stores located on both towers share a separate waste storage room located in the North Tower, also on the ground floor;
- A loading bay is available for picking up the waste from both towers' residential units and from retail.
- A staging pad for waste pickup is located by the loading bay, under the podium;
- For collection of either residential or retail waste, the containers or carts will be moved to the loading space and staging pad to be hauled;
- Residential waste will be serviced by the City of Ottawa, while retail waste will have to be collected by a private service provider;
- A garbage compactor will be located in each residential waste storage room under the garbage chute. These compactors would be accessible only to building employees;
- A cardboard baler might be located in the waste storage rooms;
- A bulky storage area might be available to be used for collection of other materials eligible for special collection services, such as batteries, mercury lamps or electronics;

Figure 1: Plan Presenting Location of Garbage Rooms

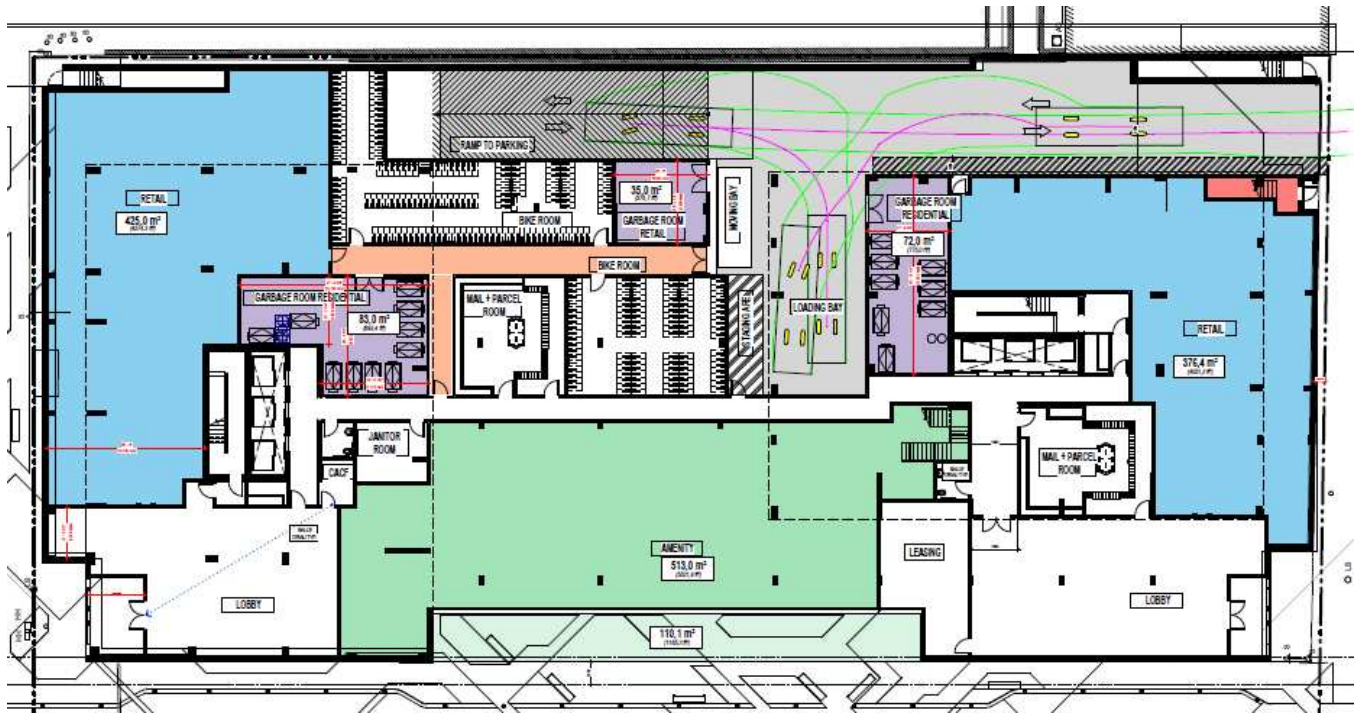
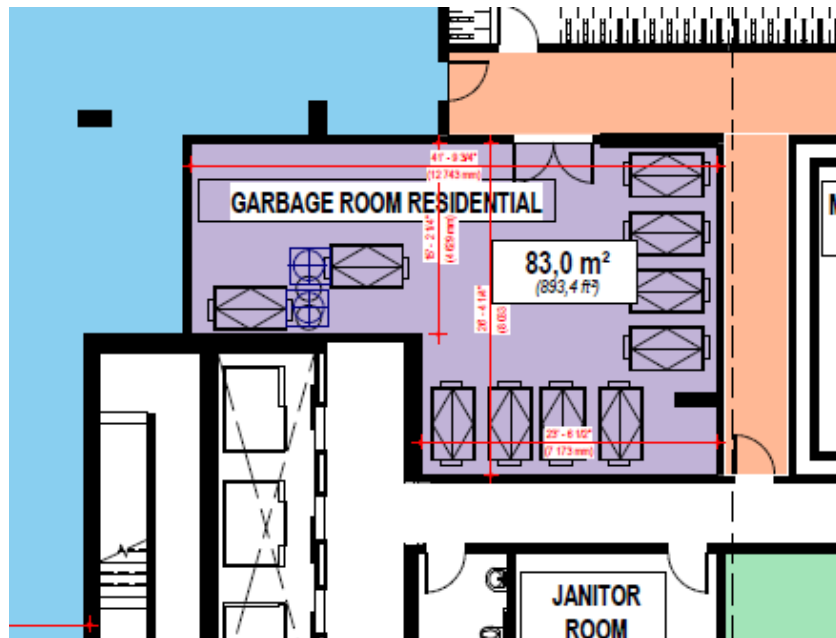
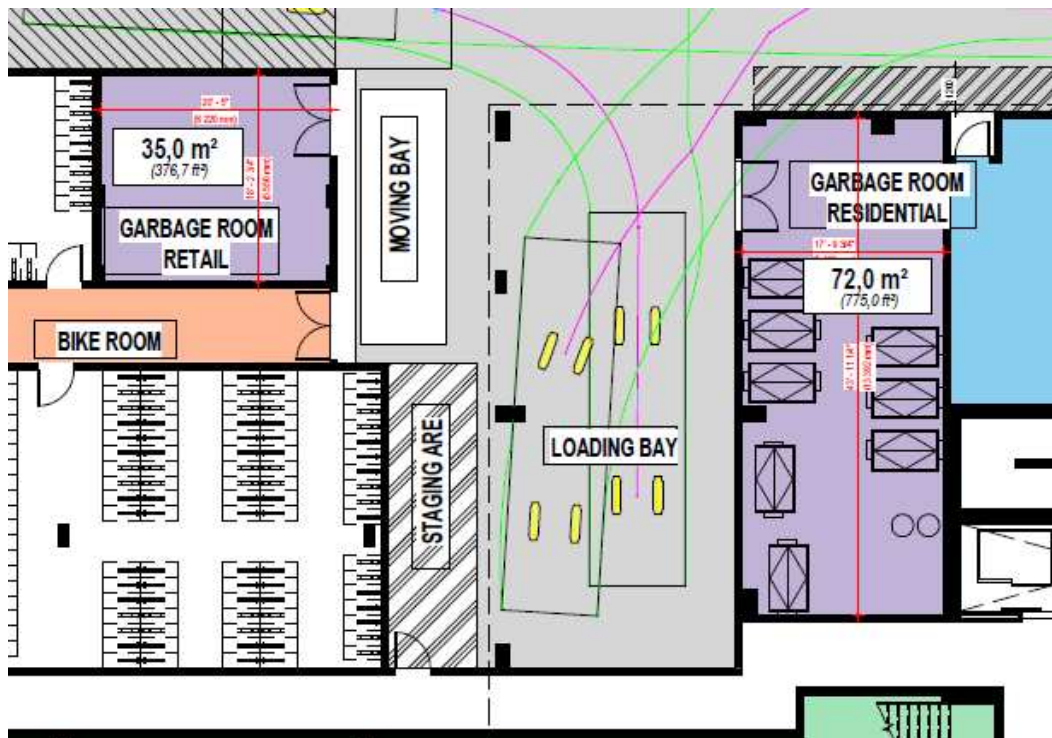

Figure 2: Garbage Room – Residential – North Tower



**Figure 3: Garbage Rooms – Retail + Residential – South Tower + loading bay and staging area**



### 1.3 CONSTRAINTS OF THE MUNICIPAL COLLECTION SERVICE<sup>1</sup>

**Table 1** outlines the City of Ottawa’s collection design guidelines and requirements for buildings with 6 units and above. All collections are performed during the day. These parameters apply only to residential waste, as commercial waste should be hauled by a private service provider.

All waste streams must be available for the residents – Garbage, Blue Box recycling (glass, metal, and plastic), Black Box recycling (paper and cardboard) and Green Bin (organics). If chutes are planned, they should be available to collect three streams – garbage and two streams of recyclables, either using three chutes or a single chute with tri-sorter. Organics can be transported to the garbage room on the ground floor.

Front-end loading container (FEL) are mandatory in developments with more than 18 units, to be used for all streams but organics. Organics should be collected with 240 Litres green carts, supplied by the City.

The development must have at least 75% occupancy per building or project/phase to be eligible for the municipal collection. The Application Form and Acknowledgement and Release Form (see

<sup>1</sup> Sources of information:  
Steve Nardelli - Waste Management Inspector (Multi-Res Services) - 613-880-7124.  
City of Ottawa’s Solid Waste Collection Design Guidelines for Multi-Unit Residential Development, October 2012.

Section 8, Appendix G and Appendix H) have been received and approved by the City before municipal collection starts.

If the collection vehicle is required to drive onto or over a supported structure (such as an underground parking garage) the City must be provided with a letter certified by a qualified engineer that the structure can safely support a fully loaded collection vehicle weighing 35,000 kilograms.

A compactor might be used for garbage or recyclables, but not for organics.

The retail waste is not eligible for the municipal collection and must use a private hauler.

In situations where a development is unable to meet the City of Ottawa’s guidelines, then a Waste Management Brief will be required with the site plan application, to the satisfaction of Solid Waste Services. The intention of the brief is to ensure that the development has been designed with due diligence for on-site solid waste management. Pre-consultation with Solid Waste Services is recommended if a Waste Management Brief will be submitted with the Site Plan application. The following describes some (but not all) situations in which a site design might be outside the realm of these guidelines and warrant a Waste Management Brief.

More details regarding the City of Ottawa’s requirements can be consulted at sections 4 and 8.

**Table 2. Municipal Collection Parameters – City of Ottawa**

Waste stream	Types of equipment accepted	Frequency of collection
Garbage	Front-end loading container Containers up to 8 yd <sup>3</sup> are allowed. For compacted containers, 4 yd <sup>3</sup> is the maximum size allowed.	Once a week
Recyclables – black box and blue box*	Front-end containers (with or without compaction). Containers up to 8 yd <sup>3</sup> are allowed (provided by the City).	Once a week
Organic materials	240 litres rolling carts (provided by the City).	Once a week

\* Blue box is for glass, metal and plastic. Black box is for paper/cardboard.

## 2.WASTE GENERATION EVALUATION

**Table 3** presents the weekly volume estimates considering the parameters described in Section 1.1. The weights are first calculated and then transposed into volume by applying standard densities.

**Table 3. Weekly generation of the different collection streams in volume (estimates)**

	Number of units	Volume of garbage	Volume of Blue Box	Volume of Black Box	Volume of organics
North Tower – residential	173 units	19.03 vg <sup>3</sup>	3.11 vg <sup>3</sup>	6.57 vg <sup>3</sup>	1.09 vg <sup>3</sup>
South Tower – residential	184 units	20.24 vg <sup>3</sup>	3.31 vg <sup>3</sup>	6.99 vg <sup>3</sup>	1.16 vg <sup>3</sup>
Podium (residential)	181 units	19.91 vg <sup>3</sup>	3.26 vg <sup>3</sup>	6.88 vg <sup>3</sup>	1.14 vg <sup>3</sup>
North Tower – commercial*	467.5 m <sup>2</sup>	0.56 v <sup>3</sup>	0.10 v <sup>3</sup>	0.57 v <sup>3</sup>	0.02 v <sup>3</sup>
South Tower – commercial*	376.4 m <sup>2</sup>	0.50 v <sup>3</sup>	0.09 v <sup>3</sup>	0.50 v <sup>3</sup>	0.02 v <sup>3</sup>

\* Considering retail – boutique use.

## 3. INDOOR STORAGE SCENARIOS

### 3.1 EVALUATION OF REQUIRED INTERIOR AREAS – GARBAGE ROOMS (RESIDENTIAL UNITS AND RETAIL STORE)

Before developing storage layout and process scenarios, it is important to validate the space required to store these materials according to the use of different types of equipment and the different collection frequencies, which is presented below in **Table 4** (garbage), **Table 5** (Black Box), **Table 6** (Blue Box), and **Table 7** (organics). Those scenarios are compared with the minimal exigences from the City of Ottawa, to be validated.

Regarding the tables:

- This tables present equipment for the garbage rooms of the **two residential towers + the podium and the retail stores**;
- Other types of containers exist and could be considered, but the tables include the most common types and those most appropriate for the project;
- All tables include one extra container per stream to be left in the garbage room while the others are taken out for collection;
- The surfaces include the minimum space for handling the equipment despite the presence of corners, doors, and columns;
- The area needed for the compactor is included. A conservative compaction ratio of 2:1 is used for garbage.

The municipal collection service available is indicated in **bold** in the tables. The recommended equipment, that respects the municipal collection requirements, is indicated in **bold and blue**.



**Table 4. Estimated indoor storage areas and number of containers – Garbage**

	2 yd <sup>3</sup> compacted	3 yd <sup>3</sup> compacted	4 yd <sup>3</sup> compacted	6 yd <sup>3</sup> non- compacted
North Tower + ½ Podium – residential	388 ft <sup>2</sup> (7 + 1 containers)	326 ft <sup>2</sup> (5 + 1 containers)	334 ft <sup>2</sup> (4 + 1 containers)	480 ft <sup>2</sup> (5 + 1 containers)
South Tower + ½ Podium – residential	430 ft <sup>2</sup> (8 + 1 containers)	326 ft <sup>2</sup> (5 + 1 containers)	334 ft <sup>2</sup> (4 + 1 containers)	560 ft <sup>2</sup> (6 + 1 containers)
	360 litre carts	660 litre carts	2 yd <sup>3</sup> non- compacted	3 yd <sup>3</sup> non- compacted
Commercial	50 ft <sup>2</sup> (3 + 1 carts)	68 ft <sup>2</sup> (2 + 1 carts)	82 ft <sup>2</sup> (1 + 1 containers)	90 ft <sup>2</sup> (1 + 1 containers)

**Table 5. Estimated indoor storage areas and number of containers – Black Box**

	2 yd <sup>3</sup> non- compacted	3 yd <sup>3</sup> non- compacted	4 yd <sup>3</sup> non- compacted	6 yd <sup>3</sup> non- compacted
North Tower + ½ Podium – residential	288 ft <sup>2</sup> (6 + 1 containers)	222 ft <sup>2</sup> (4 + 1 containers)	220 ft <sup>2</sup> (3 + 1 containers)	240 ft <sup>2</sup> (2 + 1 containers)
South Tower + ½ Podium – residential	288 ft <sup>2</sup> (6 + 1 containers)	222 ft <sup>2</sup> (4 + 1 containers)	220 ft <sup>2</sup> (3 + 1 containers)	240 ft <sup>2</sup> 2 + 1 containers)
	360 litre carts	660 litre carts	2 yd <sup>3</sup> non- compacted	3 yd <sup>3</sup> non- compacted
Commercial	38 ft <sup>2</sup> (2 + 1 carts)	46 ft <sup>2</sup> (1 + 1 carts)	82 ft <sup>2</sup> (1 + 1 containers)	90 ft <sup>2</sup> (1 + 1 containers)

**Table 6. Estimated indoor storage areas and number of containers – Blue Box**

	2 yd <sup>3</sup> non-compacted	3 yd <sup>3</sup> non-compacted	4 yd <sup>3</sup> non-compacted	6 yd <sup>3</sup> non-compacted
<b>North Tower + ½ Podium – residential</b>	<b>164 ft<sup>2</sup> (3 + 1 containers)</b>	<b>134 ft<sup>2</sup> (2 + 1 containers)</b>	<b>164 ft<sup>2</sup> (2 + 1 containers)</b>	<b>160 ft<sup>2</sup> (1 + 1 containers)</b>
	<b>2 yd<sup>3</sup> non-compacted</b>	<b>3 yd<sup>3</sup> non-compacted</b>	<b>4 yd<sup>3</sup> non-compacted</b>	<b>6 yd<sup>3</sup> non-compacted</b>
<b>South Tower + ½ Podium – residential</b>	<b>164 ft<sup>2</sup> (3 + 1 containers)</b>	<b>134 ft<sup>2</sup> (2 + 1 containers)</b>	<b>164 ft<sup>2</sup> (2 + 1 containers)</b>	<b>160 ft<sup>2</sup> (1 + 1 containers)</b>
	<b>360 litre carts</b>	<b>660 litre carts</b>	<b>2 yd<sup>3</sup> non-compacted</b>	<b>3 yd<sup>3</sup> non-compacted</b>
<b>Commercial</b>	26 ft <sup>2</sup> (1 + 1 carts)	46 ft <sup>2</sup> (1 + 1 carts)	82 ft <sup>2</sup> (1 + 1 containers)	90 ft <sup>2</sup> (1 + 1 containers)

**Table 7. Estimated indoor storage areas and number of containers – Organics**

	240 litre cart	360 litre cart
<b>North Tower + ½ Podium – residential</b>	<b>70 ft<sup>2</sup> (6 + 1 carts)</b>	62 ft <sup>2</sup> (4 + 1 carts)
	<b>240 litre cart</b>	<b>360 litre cart</b>
<b>South Tower + ½ Podium – residential</b>	<b>70 ft<sup>2</sup> (6 + 1 carts)</b>	62 ft <sup>2</sup> (4 + 1 carts)
	<b>240 litre cart</b>	<b>360 litre cart</b>
<b>Commercial</b>	20 ft <sup>2</sup> (1 + 1 carts)	26 ft <sup>2</sup> (1 + 1 carts)

Retail waste is not eligible for a municipal collection and therefore needs a private service provider to be collected.

Considering a once-a-week collection for the waste, the estimated size for the garbage rooms is:

**For the North Tower (including ½ of the Podium’s waste generation) – 752 ft<sup>2</sup> (69.9 m<sup>2</sup>)** for garbage collected with 3 yd<sup>3</sup> compacted containers, fibres (Black Box) collected with 3 yd<sup>3</sup> non-compacted containers, containers (Blue Box) collected with 3 yd<sup>3</sup> non-compacted containers and organics (Green Bin) collected with 240 litres carts. To be noted that the **planned North Tower garbage room measures 83.0 m<sup>2</sup>.**

**For the South Tower (including ½ of the Podium’s waste generation) – 752 ft<sup>2</sup> (69.9 m<sup>2</sup>)** for garbage collected with 3 yd<sup>3</sup> compacted containers, fibres (Black Box) collected with 3 yd<sup>3</sup> non-compacted containers, containers (Blue Box) collected with 3 yd<sup>3</sup> non-compacted containers and organics (Green Bin) collected with 240 litre carts. The **planned South Tower Garbage Room measures 72.0 m<sup>2</sup>**.

**For the commercial waste (private collection) – a minimum of 134 ft<sup>2</sup> (12.4 m<sup>2</sup>)** for garbage collected with 360 litre carts, fibres (Black Box) collected with 360 litre carts, containers (Blue Box) collected with 360 litre carts and organics (Green Bin) collected with 240 litre carts. The **planned retail garbage room measures 35.0 m<sup>2</sup>**.

These areas include sufficient space for manoeuvring the containers and for extra containers if needed. To be noted that compacted containers for garbage bigger than 3 yd<sup>3</sup> are not recommended because of their weight.

It is anticipated but not confirmed that a baler and cardboard bales fits in the garbage rooms, as they will replace containers needed for cardboard (Black Box). To note that Black Box containers will still be needed for papers collection and for accumulating cardboard brought in by residents. The possibility to use a cardboard baler should be validated with the City of Ottawa, to check if it allows the installation of such equipment.

## 3.2 ADDITIONAL INFORMATION FOR INDOOR STORAGE

To the minimum areas calculated, it is recommended to add:

- A space for washing bins and containers;
- Besides the garbage rooms, an area is needed for storing bulky items (e.g., furniture) and other items eligible for special collection services. It is recommended that this area had between 100 ft<sup>2</sup> and 150 ft<sup>2</sup> (9.3 m<sup>2</sup> and 13.9 m<sup>2</sup>);
- To be noted that the compactors must not be accessible to the residents.

The indoor storage area should have:

- an adequate ventilation system and odor control to prevent the spread of odors;
- a floor drain, as the floor will need to be washed periodically;
- a water source for washing of the bins and containers;
- an epoxy coating on the concrete.

Although it is not required, it may be advisable to air-condition (10°C to 12°C) the storage room, at least for garbage and organic materials.

## 4. COLLECTION AREA REQUIREMENTS (538 UNITS)

Waste from the **residential units of both towers and the podium** will be collected at the same place in a loading bay and staging area located under the Podium. Therefore, the staging area should be large /long enough to accommodate all containers from residential units during collection time.

The retail will use the same loading bay and staging area as the residential, for waste collection.

The layout should allow containers to be accessible by the truck. Solid waste collection vehicle operator must not have to manually move the containers. However, if needed, arrangements can be made through the City's contracted hauler (at the property owner's expense) to manoeuvre a FEL garbage container for the required distance to facilitate collection.

The access route and loading area must be designed in such a way as to allow a collection vehicle to enter the site, collect the waste, and exit the site in a forward motion without the need to reverse onto a public road.

City of Ottawa's specifications for loading area and access route follows:

- Provide a loading area of 4.0 metres (13.1 ft) wide and 13.0 metres (42.6 ft) long (add 2.5 metres [8.2 ft] for each additional container) – *this will require a 40.5 m long loading area, considering 11 containers for garbage collection*;
- Ensure the loading area is level (+/- 2% grade);
- Ensure the loading area is level with the storage/collection area;
- Ensure the loading area is not higher than 0.6m (2 ft) above the driveway levels;
- Provide a vertical loading clearance of 6.1 metres (20 ft);
- Design internal access routes with a minimum width of 6 metres (19.6 ft);
- Provide "no parking" signage for all internal access routes;
- Design and construct internal access routes with a hard surface material such as asphalt or concrete to support a minimum of 35,000 kilograms (the weight of a fully loaded waste collection vehicle);
- Provide 4.4 m (14.4 ft) vertical clearance throughout the access route;
- Provide the preferred grade of +/- 2% but no more than 8% grade for the access route;
- If drive-through access is not possible, provide a "T" type turnaround (see Section 8) to ensure that the collection vehicle does not have to back up through the site or back up onto a municipal road;
- Provide a hose bib within 60 metres (197 ft) of the storage/collection area and loading area;
- Provide adequate on-site space to ensure that snow and snow storage does not impede the access route(s), the storage/collection area, or loading area.

The space required for different types of equipment are presented below in **Table 8** (garbage), **Table 9** (Black Box), **Table 10** (Blue Box), and **Table 11** (organics).

Regarding the tables:

- Tables include the number of containers to be collected **from both towers and the podium, (538 units) excluding the commercial waste;**
- Other types of containers exist and could be considered, but the tables include the most common types and those most appropriate for the project;
- Front-end containers are used in the tables;
- The surfaces include the space for handling the equipment despite the presence of corners, doors and columns.

The municipal collection service available is indicated in **bold** in the tables. The recommended equipment, that respects the municipal collection requirements, is indicated in **bold and blue**.

**Table 8. Estimated staging area needed and number of containers – Garbage**

	<b>2 yd<sup>3</sup> compacted</b>	<b>3 yd<sup>3</sup> compacted</b>	<b>4 yd<sup>3</sup> compacted</b>	<b>6 yd<sup>3</sup> non- compacted</b>
<b>North Tower + ½ Podium – residential</b>	<b>288 ft<sup>2</sup> (7 containers)</b>	<b>222 ft<sup>2</sup> (5 containers)</b>	<b>220 ft<sup>2</sup> (4 containers)</b>	<b>400 ft<sup>2</sup> (5 containers)</b>
	<b>2 yd<sup>3</sup> compacted</b>	<b>3 yd<sup>3</sup> compacted</b>	<b>4 yd<sup>3</sup> compacted</b>	<b>6 yd<sup>3</sup> non- compacted</b>
<b>South Tower + ½ Podium – residential</b>	<b>328 ft<sup>2</sup> (8 containers)</b>	<b>222 ft<sup>2</sup> (5 containers)</b>	<b>220 ft<sup>2</sup> (4 containers)</b>	<b>480 ft<sup>2</sup> (6 containers)</b>
	<b>360 litre carts</b>	<b>660 litre carts</b>	<b>2 yd<sup>3</sup> non- compacted</b>	<b>3 yd<sup>3</sup> non- compacted</b>
<b>Commercial</b>	<b>38 ft<sup>2</sup> (3 carts)</b>	<b>46 ft<sup>2</sup> (2 carts)</b>	<b>42 ft<sup>2</sup> (1 container)</b>	<b>46 ft<sup>2</sup> (1 container)</b>

**Table 9. Estimated staging area needed and number of containers – Black Box**

	2 yd <sup>3</sup> non-compacted	3 yd <sup>3</sup> non-compacted	4 yd <sup>3</sup> non-compacted	6 yd <sup>3</sup> non-compacted
<b>North Tower + ½ Podium – residential</b>	<b>246 ft<sup>2</sup> (6 containers)</b>	<b>178 ft<sup>2</sup> 4 containers)</b>	<b>164 ft<sup>2</sup> (3 containers)</b>	<b>160 ft<sup>2</sup> (2 containers)</b>
	2 yd <sup>3</sup> non-compacted	3 yd <sup>3</sup> non-compacted	4 yd <sup>3</sup> non-compacted	6 yd <sup>3</sup> non-compacted
<b>South Tower + ½ Podium – residential</b>	<b>246 ft<sup>2</sup> (6 containers)</b>	<b>178 ft<sup>2</sup> (4 containers)</b>	<b>164 ft<sup>2</sup> (3 containers)</b>	<b>160 ft<sup>2</sup> 2 containers)</b>
	360 litre carts	660 litre carts	2 yd <sup>3</sup> non-compacted	3 yd <sup>3</sup> non-compacted
<b>Commercial</b>	26 ft <sup>2</sup> (2 carts)	24 ft <sup>2</sup> (1 cart)	42 ft <sup>2</sup> (1 container)	46 ft <sup>2</sup> (1 container)

**Table 10. Estimated staging area needed and number of containers – Blue Box**

	2 yd <sup>3</sup> non-compacted	3 yd <sup>3</sup> non-compacted	4 yd <sup>3</sup> non-compacted	6 yd <sup>3</sup> non-compacted
<b>North Tower + ½ Podium – residential</b>	<b>124 ft<sup>2</sup> (3 containers)</b>	<b>90 ft<sup>2</sup> (2 containers)</b>	<b>110 ft<sup>2</sup> (2 containers)</b>	<b>80 ft<sup>2</sup> (1 containers)</b>
	2 yd <sup>3</sup> non-compacted	3 yd <sup>3</sup> non-compacted	4 yd <sup>3</sup> non-compacted	6 yd <sup>3</sup> non-compacted
<b>South Tower + ½ Podium – residential</b>	<b>124 ft<sup>2</sup> (3 containers)</b>	<b>90 ft<sup>2</sup> (2 containers)</b>	<b>110 ft<sup>2</sup> (2 container)</b>	<b>80 ft<sup>2</sup> (1 container)</b>
	360 litre carts	660 litre carts	2 yd <sup>3</sup> non-compacted	3 yd <sup>3</sup> non-compacted
<b>Commercial</b>	14 ft <sup>2</sup> (1 cart)	24 ft <sup>2</sup> (1 cart)	42 ft <sup>2</sup> (1 container)	46 ft <sup>2</sup> (1 container)

**Table 11. Estimated staging area needed and number of containers – Organics**

	240 litre cart	360 litre cart
<b>North Tower + ½ Podium – residential</b>	<b>60 ft<sup>2</sup> (6 carts)</b>	50 ft <sup>2</sup> (4 carts)
	240 litre cart	360 litre cart
<b>South Tower + ½ Podium – residential</b>	<b>60 ft<sup>2</sup> (6 carts)</b>	50 ft <sup>2</sup> (4 carts)
	240 litre cart	360 litre cart
<b>Commercial</b>	10 ft <sup>2</sup> (1 cart)	14 ft <sup>2</sup> (1 cart)

The area required for the residential stage pad is 1,100 ft<sup>2</sup> (102.2 m<sup>2</sup>) if both garbage, recyclables (Black Box and Blue Box), and organics are collected at the same time using 3 yd<sup>3</sup> containers and 240 litre carts. This area was calculated in a conservative way, with ample space between containers. If only garbage and organics are collected at the same time, the area needed is 564 ft<sup>2</sup> (52.4 m<sup>2</sup>). For only recyclables and organics, the area needed is 656 ft<sup>2</sup> (60.9 m<sup>2</sup>).

For the retail waste, the area needed is 88 ft<sup>2</sup> (8.2 m<sup>2</sup>). Since it will use the same staging area as the residential waste, the surface is more than sufficient, considering that retail waste is collected in a different date/time than the residential waste.

## 5. RECOMMENDATION

In order to minimize the space required for the waste storage rooms and the staging pad, to facilitate operations, and to respect the requirements for a municipal collection the following equipment is suggested for the **residential** part of the project:

- 3 yd<sup>3</sup> containers for the garbage stream (with compaction), collected once a week;
- 3 yd<sup>3</sup> containers for the Black Box stream, collected once a week;
- 3 yd<sup>3</sup> containers for the Blue Box stream, collected once a week;
- 240 litre carts for the organics stream, collected once a week;

A baler could be used to replace some of the containers for the Black Box stream, but a few containers will still be needed for this stream. The possibility to use a cardboard baler should be validated with the City of Ottawa, to check if it allows the installation of such equipment.

If the waste from the **retail store** is collected by a private hauler using 360 L bins instead of containers, it would allow an economy of space for the commercial garbage room. The 360 L bins could be used for garbage and recycling (both Black Box and Blue Box). Organics could be collected in 240 L bins.

## 6.CONTAINER HANDLING

Since containers must be moved from the waste storage room to the staging area, the use of a pull vehicle is recommended. Some examples of suitable vehicles are indicated below.

### WasteCaddy – DJ Products

<https://www.djproducts.com/product/dumpster-tow/>

- Base price: around 7,500 US\$ + shipping
- Tow capacity: 2.3 tonnes / 5 000 lb
- 36 volts battery system
- Speed: 0 to 6 km/h (forward and reverse)
- Works on slopes, snow and ice
- Charger works on 120/220 Hz
- A more powerful model is also available:  
WasteCaddy HD model (10,300 US\$); 4.6 tonnes (10,000 lb);  
Able to pull containers over garage ramps.



<https://youtu.be/XvLYGAd2CFY>

### V-Move XL+ 1.7 KW – Verhagen

<https://www.xerowaste.ca/electric-tugs/v-move-xl-plus-electric-load-mover/>

- Base price: around 14,400 CAN\$
- Tow capacity: 7.5 tonnes / 16 535 lb
- Tow capacity: 1.1 tonne (2,500 lb) on 18% slope
- Tow capacity: 0.6 tonne (1,400 lb) on 30% slope
- Speed: 0 to 6 km/h
- Propulsion: 24 volts
- Motor type: AC
- Battery type: 2 x 12 volts 50Ah AGM no maintenance (lithium in option)
- UL / CSA approved charger included

This is a more powerful model, able to move two containers at a time on a slope. Safer. Otherwise, there is also the V-Move XL 1.5 KW model, capable of pulling 1 container at a time (9,700 CAN\$).





### AT800 TOW – MasterMover

<https://www.mastermover.com/en-ca/products/at-tow-at800-tow/>

- Full price: 34,500 CAN\$
- Tow capacity: 8 tonnes
- Propulsion: 24V, 2 x 2.0 kW
- Motor type: AC
- Battery: 24 Volts, 119 Ah (lithium in option)
- Max speed: 5 km/h
- Range of 4 km



## 7. ELIGIBLE CONTAINERS

The dimensions and other specifications included in this section are examples only. Final dimensions should be obtained from the selected service provider, as they could change per manufacturer or model chosen.

Container specifications from the City of Ottawa Solid Waste Collection Design Guidelines for Multi-Unit Residential Development.

## Appendix A – Waste Collection Container Dimensions

### Garbage Container Specifications

**2 yard Container:** Height 44 inch (excluding castors), Width 84 inch, Length 36 inch



84 inch pocket to pocket



36 inch

44 inch (excluding castors)

**2 Yard "Tall"**  
Height 56 inch  
Width 84 inch  
Length 25.5 inch

Photo  
Unavailable

**3 Yard Container Compacted:** Height 56 inch (excluding castors), Width 84 inch, Length 42 inch



84 inch pocket to pocket



42 inch

56 inch (excluding castors)

**3 Yard "Tall"**  
Height 62 inch  
Width 84 inch  
Length 36.5 inch

Photo  
Unavailable

**4-Yard Container:** Height 48 inch (excluding castors), Width 84 inch, Length 54 inch



84 inch pocket to pocket



54 inch

56 inch (excluding castors)

**4 Yard "Tall"**  
Height 66 inch  
Width 84 inch  
Length 40.5 inch

Photo  
Unavailable

**6 Yard Container:** Height 60 inch, Width 84 inch, Length 66 inch



84 inch pocket to pocket



66 inch

60 inch

- Please note: all bins are available with plastic lids and castors. The 6-yrd bin has no castors. The width of all bins includes side-lifting pockets.

## Recycling Container Specifications

### FEL Fibre Recycling Container Specifications

**2 Cubic Yard:** Height 38 inch (excluding castors), Width 84 inches, Length 35 inches

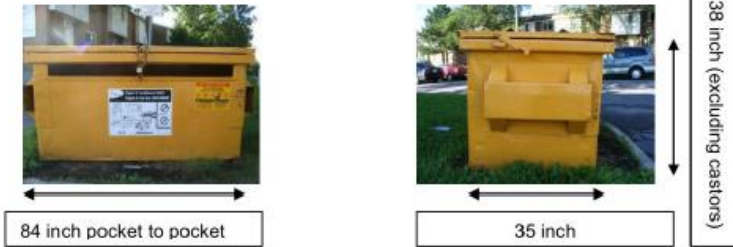

**2 Cubic Yard "Tall":** Height 58 3/8 inch (excluding castors), Width 84 inches, Length 28.25 inches

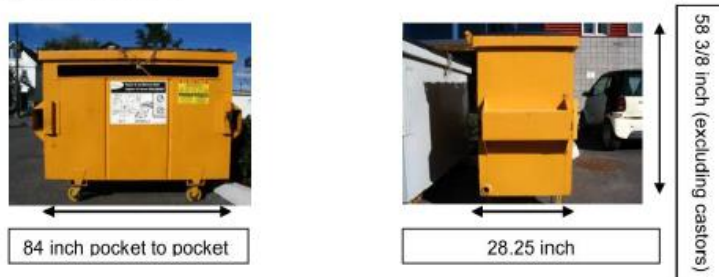

**3 Cubic Yard:** Height 48 inch (excluding castors), Width 84 inch, Length 42 inch



**4 Cubic Yard:** Height 48 inch (excluding castors), Width 84 inch, Length 54 inch

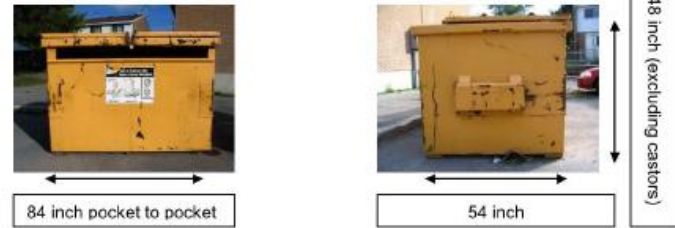

**4 Cubic Yard " Tall":** Height 58 inch (excluding castors), Width 84 inch, Length 45 1/2 inch



**6 Cubic Yard:** Height 60 inch (excluding castors), Width 84 inch, Length 67 inch

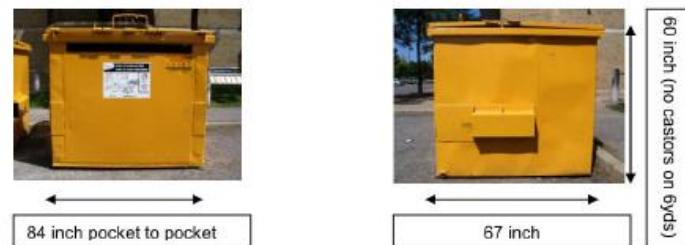

**2 Cubic Yard (Slant Style):** Height 38 inch/front 44 inch/rear (excluding castors), Width 84 inch, Length 36 inch

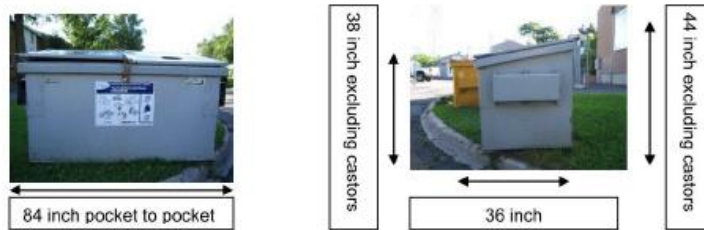

**4 Cubic Yard Slant Style:** Height 48 inch/front, 64 inch/rear (excluding castors), Width 84 inches, Length 48 inches

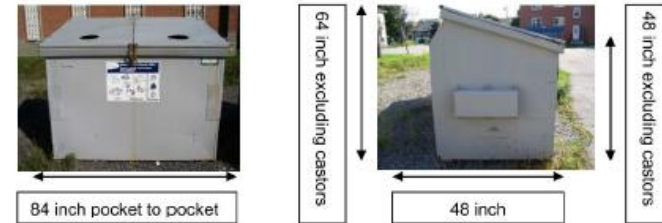

**2 Cubic Yard (Flat Style) "Tall":** Height 48 inches (excluding castors), Width 84 inches, Length 36 inches



**4 Cubic Yard "Tall":** Height 58 inches (excluding castors), Width 84 inches, Length 45 1/2 inches



**6 Cubic Yard:** Height 60 inches (excluding castors), Width 84 inches, Length 67 inches



**3 Cubic Yard:** Height 43 inch/front 48 inch/rear (excluding castors), Width 84 inch, Length 43 inch

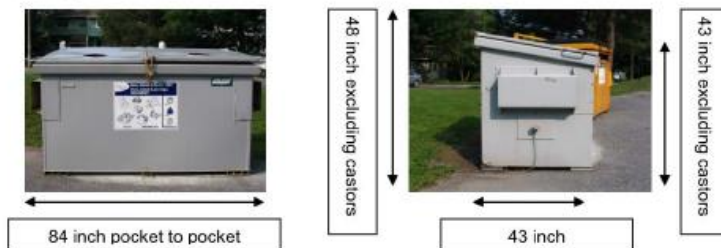

**RECYCLING CART SPECIFICATIONS**

**Recycling Carts:** Height 46.50 inch, Width 26.38 inch, Depth 33.62 inch



## **Stationary mini-compactor 0.4 yd<sup>3</sup> <sup>2</sup>**

### Advantages:

- Designed to be used with garbage or recycling chutes,
- Reduces collection frequency by reducing the volume of material by 2 to 4 times, thus reducing the number of containers required and the space used by the containers,
- Deploys a superior and constant compaction force,
- Can be installed in any type of waste room,
- Safe equipment,
- Autonomous operation - human intervention only to change the container,
- Can be adapted to compact without being attached to a chute.



### Disadvantages:

- Cost in investment, maintenance, and operation;
- Weight of the bin is increased, therefore less easy to handle;
- Requires metal containers on wheels;
- Requires a bin lift if used without a chute.

<b>Technical Specifications</b>	
Capacity	0.4 cubic yard capacity 28" x 24" (71 x 61 cm) loading opening Cycle time: 35 seconds
Dimensions	Width: 40½" (103 cm) Length: 71" (180 cm) Height: 38" without hopper (97 cm) Weight: 1,400 lbs (635 kg)
Design	Motor: 3 HP, 600 volts Cylinder: 3" (7.5 cm)

---

<sup>2</sup> <https://industek.com/en/products/mini-stationary-compactor-fk04/>

## **8. SECTIONS FROM THE CITY OF OTTAWA SOLID WASTE COLLECTION DESIGN GUIDELINES FOR MULTI-UNIT RESIDENTIAL DEVELOPMENT**

Appendix C – 'T'-Turnaround Specification

Appendix F – Site Plan Checklist for Solid Waste Collection Design

Appendix G – Application Form for Solid Waste Collection

Appendix H – Acknowledgement and Release Form

Appendix I – Example Site Plan Agreement Conditions

### Appendix C – "T"-Turnaround Specification

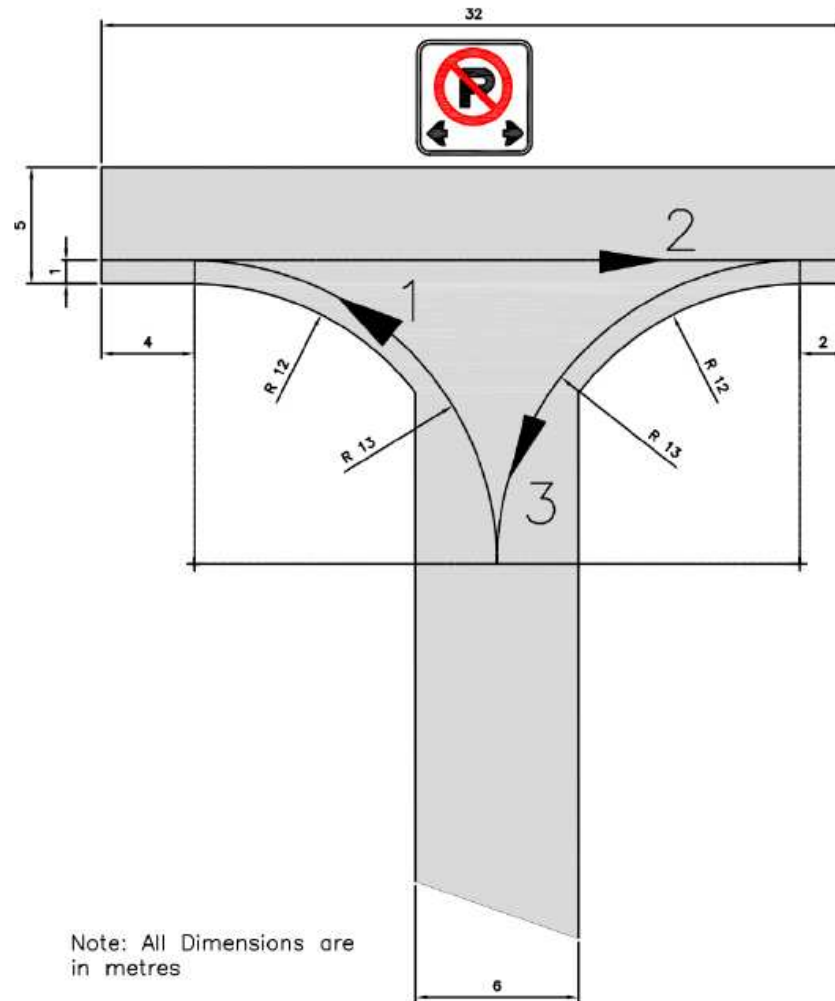

Note: All Dimensions are in metres



## Appendix F – Site Plan Checklist for Solid Waste Collection Design

Ensure that the following have been identified on the site plan drawing:	Check
Number of dwelling units and number of storeys in the development	<input type="checkbox"/>
Proposed waste handling system for recyclables, organics and garbage	<input type="checkbox"/>
Size and number of garbage and recycling receptacles to be used (i.e. for multi-unit buildings receiving front-end and/or semi-automated waste collection services)	<input type="checkbox"/>
Loading facilities	<input type="checkbox"/>
All waste storage facilities	<input type="checkbox"/>
All waste collection areas	<input type="checkbox"/>
Access routes and dimensions for waste collection vehicles on private property	<input type="checkbox"/>
Above ground features such as parking areas in relation to the access route	<input type="checkbox"/>
Pedestrian routes and building access(es) in relation to the access route	<input type="checkbox"/>
Waste Management Brief if applicable	<input type="checkbox"/>

## Appendix G – Application Form for Solid Waste Collection

### APPLICATION FOR PRIVATE PROPERTY WASTE COLLECTION SERVICES



Corporation  
of the  
City of Ottawa

City of Ottawa  
3rd Floor, 150 Katimavik  
Kanata, ON K2L 2N2

Application for Private Property  
Waste Collection Services

Date: / /

The undersigned requests the waste collection service(s) as provided by the City of Ottawa,  
Public Works and Services.

Please indicate which service you require

- |  |   |
|--|---|
| <input type="checkbox"/> Front-End Container Service | <input type="checkbox"/> Curbside Drive-Through Service |
| <input type="checkbox"/> Apartment Recycling         | <input type="checkbox"/> Curbside Recycling             |

Applicant \_\_\_\_\_ Property Owner \_\_\_\_\_

Address of Owner \_\_\_\_\_

City \_\_\_\_\_ Postal Code \_\_\_\_\_ Phone Number \_\_\_\_\_

Collection is requested at:

Name of Property \_\_\_\_\_ Contact \_\_\_\_\_

Address \_\_\_\_\_ Phone Number \_\_\_\_\_

Building Type \_\_\_\_\_ Number of Containers \_\_\_\_\_

Site Plan Number \_\_\_\_\_ Size of Containers \_\_\_\_\_ Cu. Yd.

Number of Units \_\_\_\_\_ Number of Pick-Up Locations \_\_\_\_\_

Condominium?  Yes  No Is Garbage Compacted?  Yes  No

Size of Enclosures \_\_\_\_\_ Number Enclosures \_\_\_\_\_

#### Important Information

- ~ Collection area to be signed and kept clear of parked vehicles
- ~ Collection area must be fully plowed and salted during winter months
- ~ Do not place scrap in front of bins
- ~ Regularly clean and sanitize containers
- ~ All waste must be set out for pick up before 7 am on your scheduled collection day

Note: Requests will not be processed unless the attached general release form is signed and sealed.  
All applicants must provide a reduced site plan.

#### For Office Use Only

Application Inspected by \_\_\_\_\_ Date of Inspection: \_\_\_\_\_

Service Start Date \_\_\_\_\_ Zone \_\_\_\_\_

Garbage Collection Days \_\_\_\_\_ Scrap Collection Day \_\_\_\_\_

\_\_\_\_\_ Recycling Collection Days \_\_\_\_\_

#### Comments

City of Ottawa Solid Waste Services Branch, 3rd Floor 150 Katimavik, Kanata, ON K2L 2N2

## Appendix H – Acknowledgement and Release Form



Corporation  
of the  
City of Ottawa

City of Ottawa  
3rd Floor, 150 Katimavik  
Kanata, ON K2L 2N2

Acknowledgement  
and Release

### ACKNOWLEDGEMENT AND RELEASE

- 1) In consideration of the Corporation of the City of Ottawa (hereinafter the "City") providing a waste collection service, \_\_\_\_\_ (hereinafter the "Owner") being the registered Owner of \_\_\_\_\_ (hereinafter the "lands") shall:
  - a) Permit the City and its authorized agents entry onto the land for purposes of waste collection; and
  - b) Release and agree to indemnify the City from all actions, causes of actions, damages, claims and demands arising as a result of the City and its agenda utilizing the driveway ramp, loading and parking areas of the lands for purposes of providing waste collection service, save and except any claims or damages attributable to the negligence of the City or those for whom it is in law responsible.
- 2) It is herein acknowledged by the Owner that the City's waste collection for the lands is conditional on:
  - a) The Owner providing free and clear access to a collection point determined satisfactory by the Public Works and Services for these purposes. The Owner's proposed route of access for collection purposes as set out on a plot plan of the building and parking lot which is attached hereto:

- b) The Owner utilizing waste containers approved by the City's Deputy City Manager of Public Works and Services
- c) The Owner maintaining all compaction equipment containers in good and operable condition; and
- d) All designated waste being set up for collection in approved containers no later than 7:00 a.m. on the designated date for collection.

- 3) The Owner further acknowledges the City's waste collection service is limited to:
  - a) Services as outlined in the City of Ottawa's Solid Waste Management By-law.
- 4) The Owner further acknowledges that the City shall not collect garbage generated from building renovations, white goods and appliances, apartment fires, parking lot sweepings or appliances being replaced on a mass basis. All materials to be collected must be in accordance with the Solid Waste Management By-law.

DATED AT \_\_\_\_\_ this \_\_\_\_\_ day of \_\_\_\_\_

SIGNED SEALED AND DELIVERED )  
 ) (Company Name)  
 ) Per: \_\_\_\_\_  
 ) Name: \_\_\_\_\_  
 ) Title: \_\_\_\_\_  
 ) Per: \_\_\_\_\_  
 ) Name: \_\_\_\_\_  
 ) Title: \_\_\_\_\_