

GWL Realty Advisors

170 Slater Street

**Transportation
Impact
Assessment**



170 Slater Street

Transportation Impact Assessment

Step 1 Screening Report

Step 2 Scoping Report

Step 3 Forecasting Report

Step 4 Strategy Report

Prepared for:

GWL Realty Advisors
33 Yonge Street, Suite 1000,
Toronto, Canada M5E 1G4

Prepared by:



6 Plaza Court
Ottawa, ON K2H 7W1

July 2023

PN: 2023-006

Table of Contents

1	Screening.....	1
2	Existing and Planned Conditions.....	1
2.1	Proposed Development.....	1
2.2	Existing Conditions.....	2
2.2.1	Area Road Network.....	2
2.2.2	Existing Intersections.....	2
2.2.3	Existing Driveways.....	3
2.2.4	Cycling and Pedestrian Facilities.....	4
2.2.5	Existing Transit.....	6
2.2.6	Existing Area Traffic Management Measures.....	8
2.2.7	Existing Peak Hour Travel Demand.....	8
2.2.8	Collision Analysis.....	10
2.3	Planned Conditions.....	14
2.3.1	Changes to the Area Transportation Network.....	14
2.3.2	Other Study Area Developments.....	14
3	Study Area and Time Periods.....	15
3.1	Study Area.....	15
3.2	Time Periods.....	15
3.3	Horizon Years.....	15
4	Exemption Review.....	15
5	Development-Generated Travel Demand.....	16
5.1	Mode Shares.....	16
5.2	Trip Generation.....	16
5.3	Trip Distribution.....	17
5.4	Trip Assignment.....	18
6	Background Network Travel Demands.....	20
6.1	Transportation Network Plans.....	20
6.2	Background Growth.....	20
6.3	Other Developments.....	20
7	Demand Rationalization.....	21
7.1	2028 Future Background Operations.....	21
7.2	2033 Future Background Operations.....	23
7.3	2028 Future Total Operations.....	24
7.4	2033 Future Total Operations.....	26
7.4.1	Network Rationalization.....	28
7.4.2	Development Rationalization.....	28
8	Development Design.....	28
8.1	Design for Sustainable Modes.....	28
8.2	Circulation and Access.....	29
9	Boundary Street Design.....	30
10	Access Intersections Design.....	30
10.1	Location and Design of Access.....	30

10.2 Intersection Control..... 31

10.3 Access Intersection Design 31

 10.3.1 Future Access Intersection Operations 31

 10.3.2 Access Intersection MMLOS 31

 10.3.3 Recommended Design Elements..... 31

11 Transportation Demand Management 32

 11.1 Context for TDM 32

 11.2 Need and Opportunity..... 32

 11.3 TDM Program 32

12 Transit..... 32

 12.1 Transit Priority 32

13 Network Intersection Design..... 33

 13.1 Network Intersection Control..... 33

 13.2 Network Intersection Design..... 33

 13.2.1 2028 & 2033 Future Total Network Intersection Operations 33

 13.2.2 Network Intersection MMLOS..... 33

 13.2.3 Recommended Design Elements..... 33

14 Summary of Improvements Indicated and Modifications Options..... 34

15 Conclusion 37

List of Figures

Figure 1: Area Context Plan2

Figure 2: Concept Plan.....1

Figure 3: Existing Driveways4

Figure 4: Study Area Pedestrian Facilities4

Figure 5: Study Area Cycling Facilities5

Figure 6: Existing Pedestrian Volumes5

Figure 7: Existing Cyclist Volumes6

Figure 8: Existing Study Area OC-Transpo Service.....7

Figure 9: Existing Study Area STO Service7

Figure 10: Existing Study Area Transit Stops8

Figure 11: Existing Traffic Counts9

Figure 12: Representation of Study Area Collision Records..... 11

Figure 13: New Site Generation Auto Volumes..... 18

Figure 14: Reduction from the Existing Site 19

Figure 15: Net Total Volumes 19

Figure 16: Background developments volumes 21

Figure 17: 2028 Future Background Volumes 22

Figure 18: 2033 Future Background Volumes 23

Figure 19: 2028 Future Total Volumes 25

Figure 20: 2033 Future Total Volumes 27

Table of Tables

Table 1: Intersection Count Date.....	8
Table 2: Existing Intersection Operations.....	9
Table 3: Study Area Collision Summary, 2016-2020	10
Table 4: Summary of Collision Locations, 2016-2020.....	11
Table 5: Laurier Avenue West and O’Connor Street Collision Summary	12
Table 6: Bank Street at Laurier Avenue West Collision Summary.....	12
Table 7: O’Connor Street and Slater Street Collision Summary	13
Table 8: Bank Street at Slater Street Collision Summary	13
Table 9: Exemption Review	15
Table 10: TRANS Trip Generation Manual Recommended Mode Shares – Ottawa Centre	16
Table 11: Trip Generation Person Trip Rates	16
Table 12: Total Person Trip Generation	16
Table 13: Internal Capture Rates.....	17
Table 14: Trip Generation by Mode	17
Table 15: OD Survey Distribution – Ottawa Centre.....	18
Table 16: Trip Assignment.....	18
Table 17: TRANS Regional Model Projections – Study Area Growth Rates.....	20
Table 18: Recommended Area Growth Rates	20
Table 19: 2028 Future Background Intersection Operations	22
Table 20: 2033 Future Background Intersection Operations	23
Table 21: 2028 Future Total Intersection Operations	25
Table 22: 2033 Future Total Intersection Operations	27
Table 23: Auto Parking Provisions.....	29
Table 24: Bicycle Parking Provisions.....	30
Table 25: Boundary Street MMLoS Analysis.....	30
Table 26: Trip Generation by Transit Mode	32
Table 27: Forecasted Site-Generated Transit Ridership.....	32
Table 28: Study Area Intersection MMLoS Analysis	33

List of Appendices

Appendix A – TIA Screening Form and Certification Form
Appendix B – Turning Movement Count Data
Appendix C – Synchro Intersection Worksheets – Existing Conditions
Appendix D – Collision Data
Appendix E – TRANS Model Plots
Appendix F – Intersection Traffic Growth Rate between 2000 and 2016
Appendix G – Background Development Volumes
Appendix H – Synchro Intersection Worksheets – 2028 Future Background Conditions
Appendix I – Synchro Intersection Worksheets – 2033 Future Background Conditions
Appendix J – Synchro Intersection Worksheets –2028 Future Total Conditions
Appendix K – Synchro Intersection Worksheets – 2033 Future Total Conditions
Appendix L – TDM Checklist

Appendix M – Signage Plan
Appendix N – Turning Templates
Appendix O – MMLOS Analysis

1 Screening

This study has been prepared according to the City of Ottawa's 2017 Transportation Impact Assessment (TIA) Guidelines. Accordingly, a Step 1 Screening Form has been prepared and is included as Appendix A, along with the Certification Form for the TIA Study PM. As shown in the Screening Form, a TIA is required including the Design Review component and the Network Impact Component. This study has been prepared to support a site plan application.

2 Existing and Planned Conditions

2.1 Proposed Development

The existing site, located at 170 Slater Street, is zoned as Mixed-Use Downtown Zone (MD 132 S33). The site is located inside the downtown protected major transit station area, the Central and East Downtown Core Secondary Plan, and falls within a 200-meter radius of the Parliament LRT station.

The proposed redevelopment will convert an existing multi-storey parking lot to a 25-storey and a 26-storey towers with a 7-storey podium and ground floor commercial/retail area. In total, 586 residential units and 8,498 square feet of commercial/retail will be provided with 160 auto parking spaces and 293 bike parking spaces.

Currently a full-movement access to the site is provided via Laurier Avenue West. This access also serves the above-ground parking of the BMO building at 269 Laurier Avenue West. In the past, the Laurier Avenue West access would connect to the Slater Street access via a shared laneway between 170 Slater Street and the BMO building surface parking. The Slater Street access is currently blocked by mobile signage. This access was previously closed due high volume of OC Transpo buses stopping along the site frontage on Slater Street prior to the launch of Ottawa LRT.

As part of the proposed development the shared laneway between 170 Slater Street and 269 Laurier Avenue West is proposed to be converted to one-way only, with in-only access at Laurier Avenue West, and out-only access at Slater Street. This will allow for a 1.8-meter pedestrian walkway between Slater Street and Laurier Avenue West and a passenger pick-up / drop-off area that will serve the proposed development.

The access to the ground-floor loading area and underground parking is proposed along Laurier Avenue West, approximately 35 meters west of O'Connor Avenue. The anticipated full build-out and occupancy horizon is assumed to be 2028 with construction occurring in two phases. Figure 1 illustrates the study area context. Figure 2 illustrates the proposed concept plan.

Figure 1: Area Context Plan

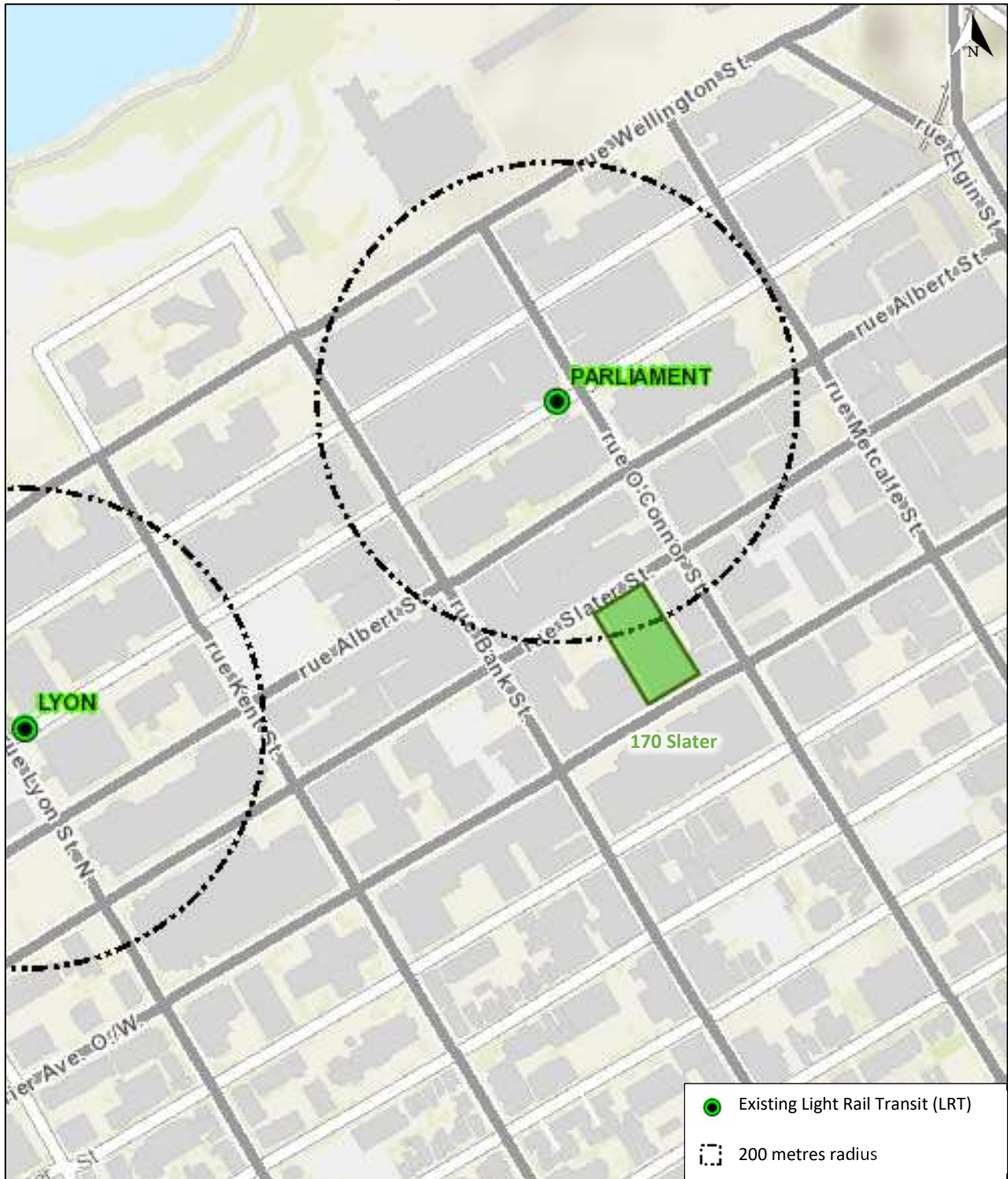

Source: <http://maps.ottawa.ca/geoOttawa/> Accessed: February 15, 2023

Figure 2: Concept Plan

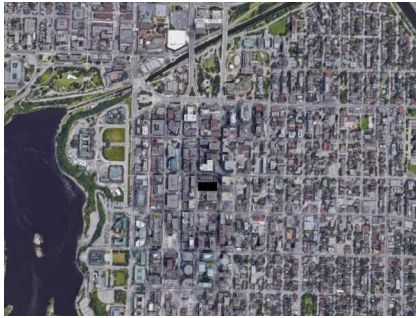

KEY PLAN

TOTAL LOT AREA (PART 1-PART 2): 8 963.70 m²		
GFA PART 1 (300 LAURIER) 26 814.74 m²		
GFA PART 2 (170 SLATER) 14 942.67 m²		
TOTAL GFA 41 757.41 m²		
ZONING (15) 533 (PART 2)		
PROVISION	REQUIRED	PROVIDED
Lot Area (m ²)	no provision	> 20 000 m ²
Year Building Starts	no provision	> 2025
Min Floor To 1st Floor	no provision	> 1.50 m (5.25 ft)
Max Floor To 1st Floor	no provision	> 1.50 m (5.25 ft)
Max Floor To 2nd Floor	no provision	> 1.50 m (5.25 ft)
Max Floor To 3rd Floor	no provision	> 1.50 m (5.25 ft)
Max Floor To 4th Floor	no provision	> 1.50 m (5.25 ft)
SITE AREA (PART 2)		
NET COVERAGE		> 4 271 m ² (To be confirmed by survey)
LANDSCAPED AREA (EXCLUDING PARKING)		> 1 250 m ²
LANDSCAPED AREA INCLUDING PARKING		> 2 280 m ²
GROUND PARKING AREA		> 2 280 m ²
LANDSCAPED AREA INCLUDING PARKING		> 1 250 m ²
NET COVERAGE (EXCLUDING PARKING)		> 1 250 m ²
SEWERAGE AND TRAFFIC LIGHTS		> 1 250 m ²
SOUTH TOWER - RESIDENTIAL RENTAL		
RENTAL FLOORS (G.A. TO 2ND FLOOR)		> 11 FLOORS
PERMITTED HEIGHT		> 130.00 m (426.51 ft)
NUMBER OF FLOORS AND BUILDING HEIGHT		24 FLOORS (including 7 floor podium)
DEVELOPMENT DENSITY		180 BICYCLES
NORTH TOWER - RESIDENTIAL RENTAL		
RENTAL FLOORS (G.A. TO 2ND FLOOR)		> 11 FLOORS
PERMITTED HEIGHT		> 130.00 m (426.51 ft)
NUMBER OF FLOORS AND BUILDING HEIGHT		24 FLOORS (including 7 floor podium)
DEVELOPMENT DENSITY		180 BICYCLES
PODIUM - RESIDENTIAL AND RETAIL RENTAL		
GROUND FLOOR (G.A.)		> 1 250 m ²
RENTAL FLOORS (G.A. TO 2ND FLOOR)		> 11 FLOORS
PERMITTED HEIGHT		> 130.00 m (426.51 ft)
NUMBER OF FLOORS AND BUILDING HEIGHT		24 FLOORS (including 7 floor podium)
DEVELOPMENT DENSITY		180 BICYCLES
TOTAL AMENITY AREA REQUIRED (SEE TABLE 2 IN PART 3 OF THE ZONING BY-LAW)		> 1 250 m ²
TOTAL COMMERCIAL AMENITY AREA PROVIDED (SEE TABLE 2 IN PART 3 OF THE ZONING BY-LAW)		> 1 250 m ²
TOTAL COMMERCIAL AMENITY AREA PROVIDED (SEE TABLE 2 IN PART 3 OF THE ZONING BY-LAW)		> 1 250 m ²
REMARKS:		
1. ALL DEVELOPMENT IS SUBJECT TO APPROVAL BY THE CITY OF OTTAWA AND THE PROVINCE OF ONTARIO.		
2. CONSULT THE CONSULTING ENGINEER AND ARCHITECT FOR MORE INFORMATION.		
3. CONSULT THE CONSULTING ENGINEER AND ARCHITECT FOR MORE INFORMATION.		
4. CONSULT THE CONSULTING ENGINEER AND ARCHITECT FOR MORE INFORMATION.		

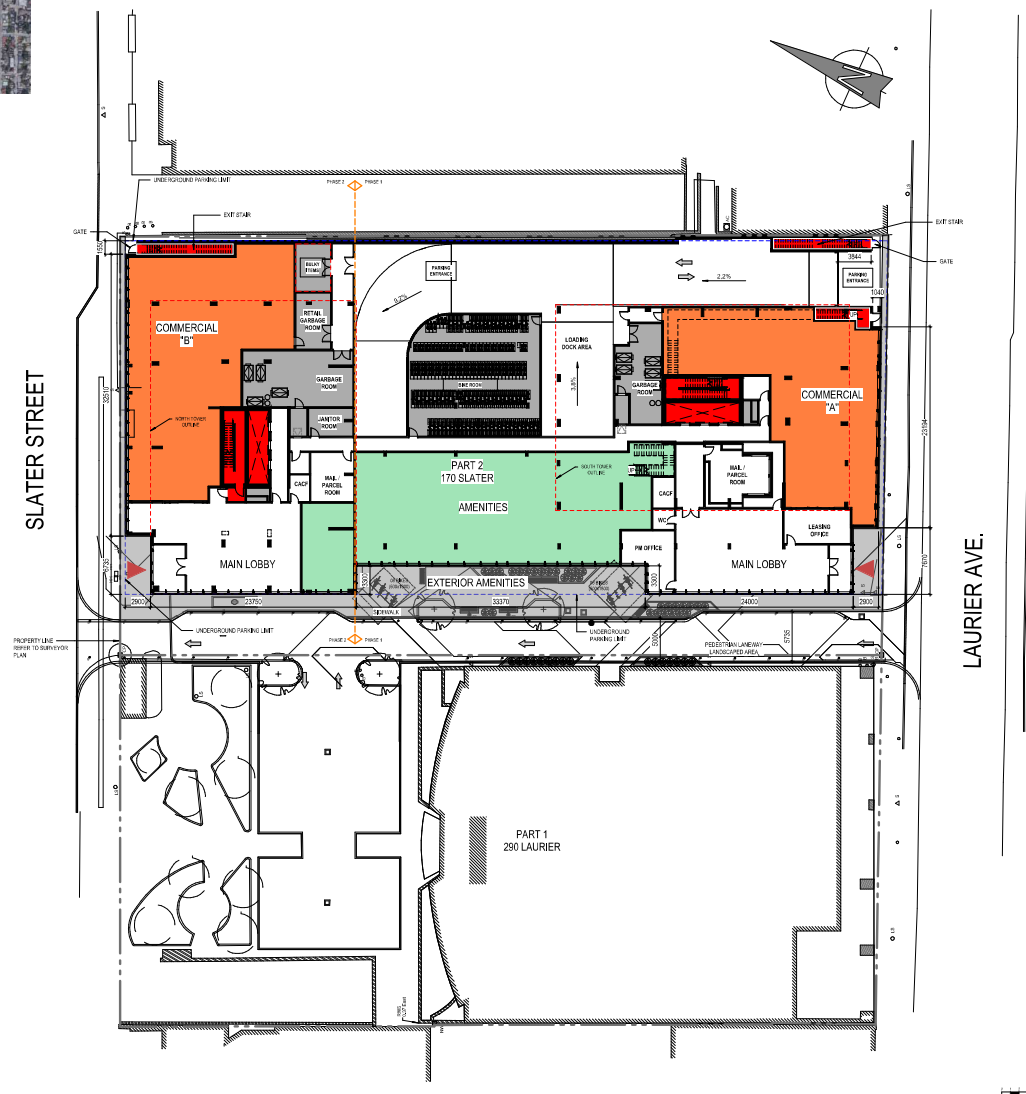

GENERAL NOTES - NOTES GENERAL:

1. THIS PLAN IS PREPARED FOR THE PURPOSES OF THE CONCEPT PLAN ONLY. IT DOES NOT REPRESENT A CONTRACTOR'S SCHEDULE OF WORKS. CONSULT THE CONSULTING ENGINEER AND ARCHITECT FOR MORE INFORMATION.
2. ALL DEVELOPMENT IS SUBJECT TO APPROVAL BY THE CITY OF OTTAWA AND THE PROVINCE OF ONTARIO.
3. CONSULT THE CONSULTING ENGINEER AND ARCHITECT FOR MORE INFORMATION.
4. CONSULT THE CONSULTING ENGINEER AND ARCHITECT FOR MORE INFORMATION.

PROJECT ARCHITECT: BUILDING DESIGN GROUP
Cleland Jardine Eng. Ltd.
 1111 1st Street, Suite 200
 Ottawa, Ontario K1P 1A5
 TEL: 613-565-4444 FAX: 613-565-4445

CONSULTING ENGINEER (PROFESSIONAL):
Goodley Woodcock & Assoc. Ltd.
 1111 1st Street, Suite 200
 Ottawa, Ontario K1P 1A5
 TEL: 613-565-4444 FAX: 613-565-4445

ARCHITECT (PROFESSIONAL):
James R. Lemay & Associates Inc.
 1111 1st Street, Suite 200
 Ottawa, Ontario K1P 1A5
 TEL: 613-565-4444 FAX: 613-565-4445

CONSULTING ENGINEER (PROFESSIONAL):
James R. Lemay & Associates Inc.
 1111 1st Street, Suite 200
 Ottawa, Ontario K1P 1A5
 TEL: 613-565-4444 FAX: 613-565-4445



GWL REALTY ADVISORS

PROJECT SOURCE:
170 SLATER

LOCATION (CLIENT ADDRESS): OTTAWA **PROJECT NO. / PROJECT NAME:** 12985.00

NO. OF SHEETS: 17 **TOTAL SHEETS:** 17
DATE: 2023-07-03 10:32:35
PROJECT: 170 SLATER

REVISIONS:

NO.	REVISION	DATE	BY
1	ISSUE FOR PERMIT	2023-07-03	BBJ
2	REVISION		
3	REVISION		

PROJECT CHECKED BY: BBJ **CHECKED BY:** BBJ
DATE: 2023-07-03 **SCALE (GRAPHIC):** 1" = 20'-0"

SITE PLAN - GROUND LEVEL

1 SPA A102

2.2 Existing Conditions

2.2.1 Area Road Network

Laurier Avenue West: Laurier Avenue West is a City of Ottawa arterial road with an urban three-lane cross-section including a parking lane on the south side of the road. Sidewalks and protected bike lanes are present on both sides of the road. Paid parking is provided on the south side for maximum one hour on weekdays from 7:30 AM to 5:30 PM. The unposted speed limit is 50km/h. The measured right-of-way is 20.0 metres.

O'Connor Street: O'Connor Street is a City of Ottawa one-way urban arterial road (southbound) with a four-lane cross-section including a parking lane on the east side of the road. A two-way protected bike lane is present on the east side of the road south of Laurier Avenue West and sidewalks are present on both sides of the road. Within the study area, paid parking is provided on the west side north of Slater Street for a maximum of one hour on weekdays from 9:00 AM to 3:30 PM. Between Slater Street and Laurier Avenue West, on-street parking is restricted on the west side from 9:00 AM to 3:00 PM, and paid parking is provided on the east side of the road from 8:00 AM to 5:30 PM for a maximum of one hour on weekdays. South of Laurier Avenue, on-street parking is provided on the west side between 7:30 AM to 5:30 PM on weekdays for maximum one hour. The unposted speed limit is 50km/h. The measured right-of-way is 20.0 metres within the study area.

Bank Street: Bank Street is a City of Ottawa urban arterial road with a two-lane cross-section and an auxiliary turn lane at Bank Street and Laurier Avenue West intersection. Sidewalks are present on both sides of the road. The unposted speed limit is 50km/h. The city-protected right-of-way is 20.0 metres within the study area.

Slater Street: Slater Street is a City of Ottawa urban one-way arterial road (eastbound) with a three-lane cross-section, including a High Occupancy Vehicle Lane and a parking lane. Stopping is prohibited along Slater Street between 7:00AM and 9:00AM and 3:00PM and 6:00PM, and parking is prohibited between 9:00AM and 3:00PM. Sidewalks are present on both sides of the road. The unposted speed limit is 50km/h. The city-protected right-of-way is 20.0 metres within the study area.

2.2.2 Existing Intersections

The study area intersections have been summarized below:

Slater Street at Bank Street

The intersection of Slater Street at Bank Street is a signalized intersection. The northbound approach consists of a shared right-turn/through lane and the southbound approach consists of a shared through/left-turn lane, and the east leg of the intersection is inbound only. The eastbound approach consists of a right-turn lane, an HOV lane, a through lane, and a left turn lane. Northbound right-turn movements are restricted between 7:00 AM to 5:30 PM on weekdays. Southbound left-turn movements are restricted with buses excepted. Eastbound left-turn movements are restricted between 7:00 to 9:00AM and 3:00 to 6:00PM on weekdays with buses and bicycles excepted.

Slater Street at O'Connor Street

The intersection of Slater Street at O'Connor Street is a signalized intersection. The southbound approach consists of three through lanes and one shared through / left turn lane, and the eastbound approach consists of a shared right-turn/through lane, an HOV lane, and two through lanes. Eastbound right-turn are restricted between 7:00 to 9:00 AM and 3:00 to 6:00 PM on weekdays with authorized

vehicles, taxis, and bicycles excepted. The south and west legs of the intersection are inbound only.

Laurier Avenue West at Bank Street

The intersection of Laurier Avenue West at Bank Street is a signalized intersection. The northbound approach consists of a through lane and a right-turn lane, and the southbound approach consists of an auxiliary right-turn lane and a through lane. The westbound approach consists of a shared through/right-turn lane, and a protected bike lane, and the eastbound approach consists of a right-turn lane, a through lane and a protected bike lane. All left-turn and all right-turns on red are restricted. Bike boxes are provided on the east and west legs of the intersection.

Laurier Avenue West at O'Connor Street

The intersection of Laurier Avenue West at O'Connor Street is a signalized intersection. The southbound approach consists of a protected bike lane, a shared left-turn/through lane, a through lane, and a shared through/right-turn lane. The south leg of the intersection is inbound only with a bi-directional protected bike facility. The eastbound approach consists of a shared through/right-turn lane and a protected bike lane, and westbound approach consists of an auxiliary left-turn lane, a through lane and a protected bike lane. Right-turn on red is restricted on the southbound and eastbound movements. Bike boxes are provided on the north, south, and east legs.

Laurier Avenue West at Site Access #1

The intersection of Laurier Avenue West at Site Access #1 a stop-controlled intersection on the minor approach. The eastbound approach consists of a shared left-turn/through lane and a protected bike lane, and westbound approach consists of a shared through/right-turn lane and a protected bike lane.

2.2.3 Existing Driveways

Existing driveways within the study area are illustrated in Figure 3. On the north side of Slater Street there are three parking garage entrances. On the south side of Slater there is an entrance to the BMO underground parking west of the proposed development, and an entrance to 110 O'Connor Street underground parking to the east of the proposed development. On the north side of Laurier Avenue West, there is an existing access to the BMO building loading docks, and the current shared access between the subject property and the BMO building surface parking lot. There are no existing driveways along the south side of Laurier Avenue West between Bank Street and Slater Street.

Figure 3: Existing Driveways



Source: <http://maps.ottawa.ca/geoOttawa/> Accessed: Feb 23, 2023

2.2.4 Cycling and Pedestrian Facilities

Figure 4 illustrates the pedestrian facilities in the study area and Figure 5 illustrates the cycling facilities.

Sidewalks are provided along both sides of the study area roads. Cycling facilities in the study area include protected bike lanes on each side of Laurier Avenue West, and a bi-directional cycle track on O'Connor Street, south of Laurier Avenue West. Slater Street is designated as a spine route, Bank Street is designated as a local route, and both Laurier Avenue West and O'Connor Street are designated as cross-town bikeways.

Figure 4: Study Area Pedestrian Facilities

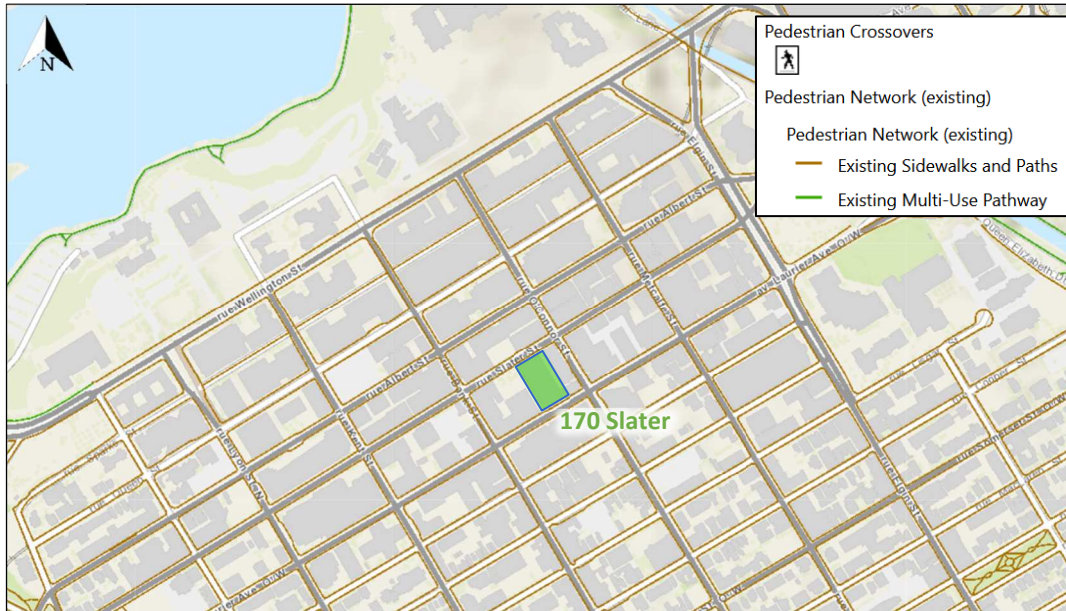

Source: <http://maps.ottawa.ca/geoOttawa/> Accessed: Feb 23, 2023

Figure 5: Study Area Cycling Facilities

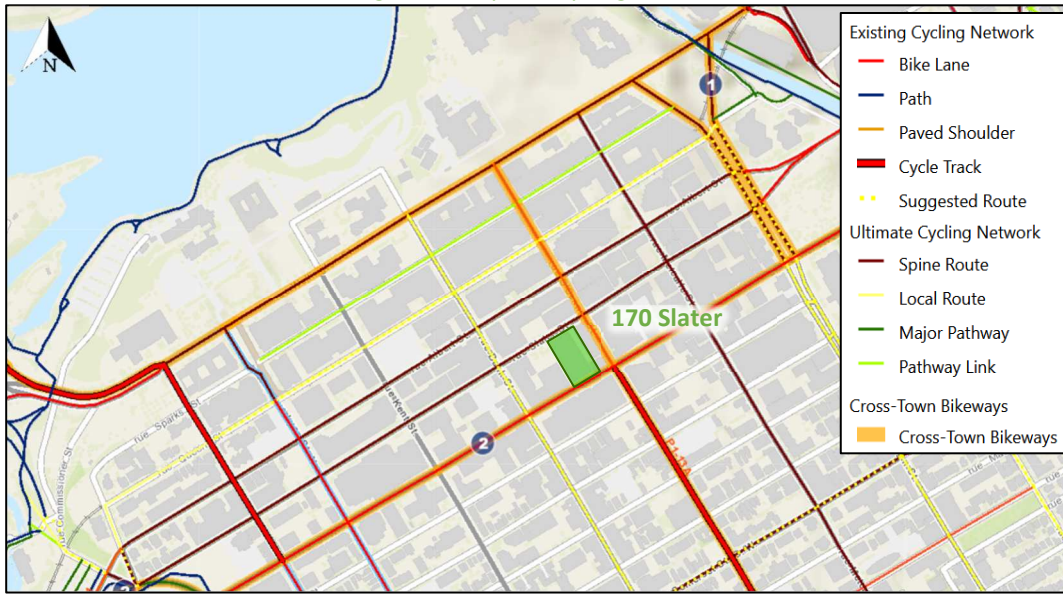

Source: <http://maps.ottawa.ca/geoOttawa/> Accessed: Feb 23, 2023

Pedestrian and cyclist volumes included in study area intersection counts, discussed in Section 2.2.7, are illustrated in Figure 6 and Figure 7, respectively. No cyclist volumes are available at the intersection of Laurier Avenue West at Site Access #1. A total of 79 AM and 67 PM cyclists were assumed on the westbound movement at Site Access #1.

Figure 6: Existing Pedestrian Volumes

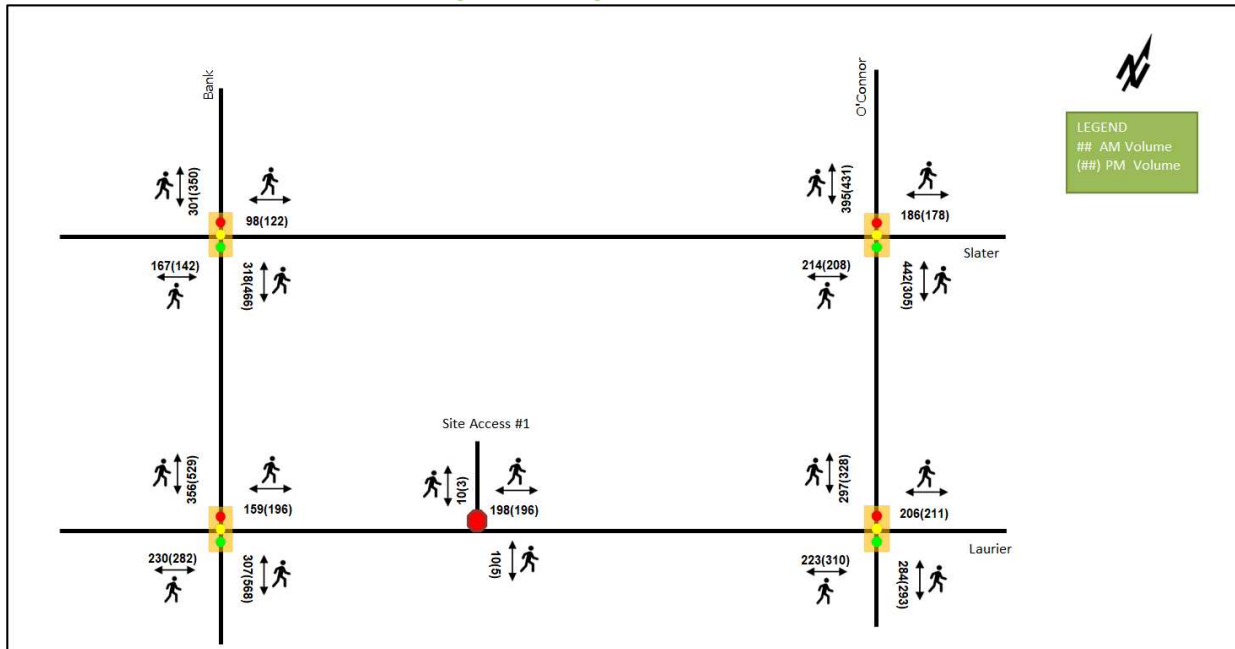
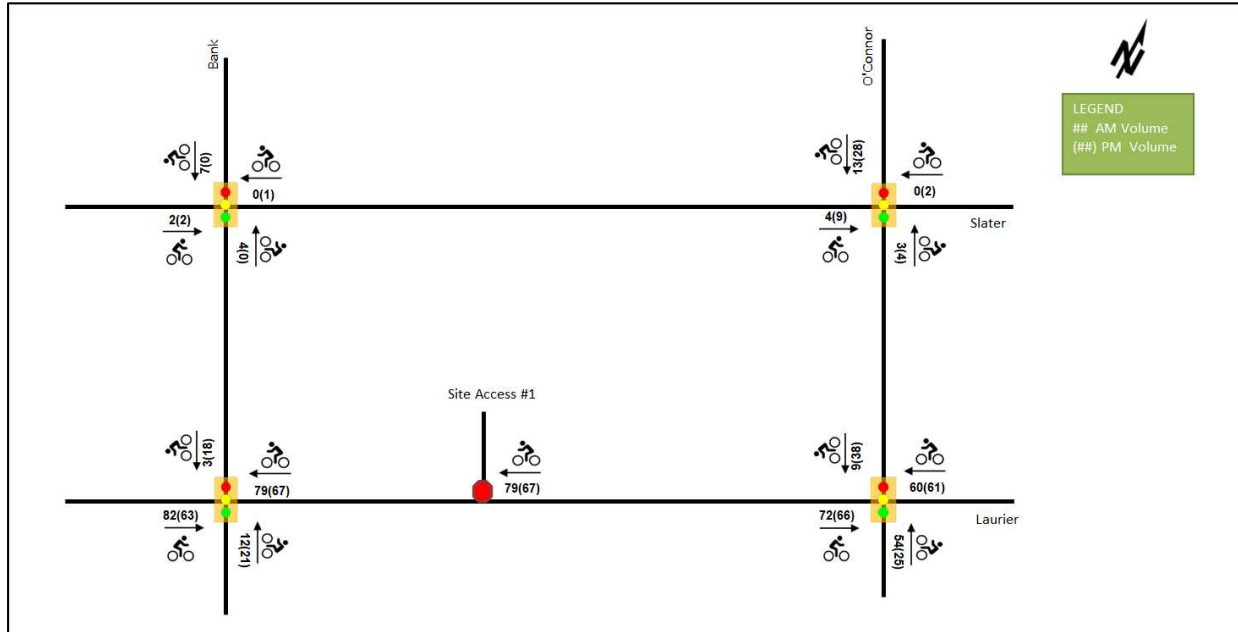

Figure 7: Existing Cyclist Volumes



2.2.5 Existing Transit

Within the study area, OC-Transpo routes #16 and #19 travel along O’Connor Street and Slater Street and routes #6, #7 and #11 travel along Bank Street. The closest OC-Transpo bus stops for these routes are located at the intersections of Slater Street at Bank Street and Slater Street at Metcalfe Street. The frequency of these routes within proximity of the proposed site, based on March 22, 2023 service levels, are:

- Route # 16 – 15-minute service before 3:00 PM, 30-minute service after 3:00 PM
- Route # 19 – 30-minute service all day
- Route # 6 – 15-minute service all day, 5-minute PM-peak hour service
- Route # 7 – 15-minute service, additional 5-minute AM-peak hour service between 6:00 AM and 9:00 AM
- Route # 11 – 10–15-minute service before 7:00 PM

The Parliament LRT station is located within a 300-metre walking distance from the site and the Lyon LRT station is located within a 600-metre walking distance from the site. The LRT provides 5-minute service during the peak hours, and 10–15-minute service otherwise.

STO routes #23, #24, #34, #67, #87 and #400 travel along Slater Street. The primary STO bus stop location is in front of 170 Slater Street. The frequency of these routes adjacent to the proposed site, based on March 22, 2023 service levels, are:

- Route # 23 – 30-minute service between 6:00 AM to 08:00 AM
- Route # 24 – 30-minute service between 6:00 AM to 09:00 AM
- Route # 34– 15-minute service between 9:00 AM to 10:00 PM
- Route # 67 – 30-minute service between 9:00 AM to 8:00 PM
- Route # 87 – 20-minute service between 5:00 AM to 09:00 AM
- Route # 400 – 10-minute service between 5:00 AM to 04:00 PM, 15-minute service between 4:00 PM to 12:00 AM

Figure 8 illustrates the OC-Transpo Service map in the study area, and Figure 9 illustrates the STO Service map in the study area. Figure 10 illustrates existing transit stops within 400 metres and the LRT stations within 800 metres of the subject site.

Figure 8: Existing Study Area OC-Transpo Service

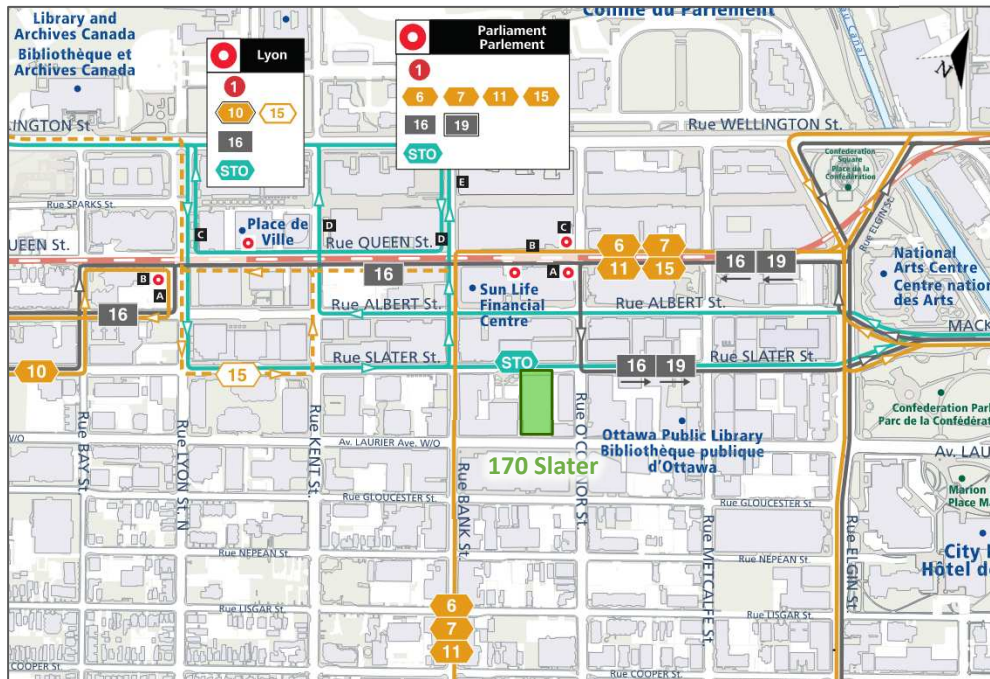

Source: <http://www.octranspo.com/> Accessed: Mar 22, 2023

Figure 9: Existing Study Area STO Service



Source: <http://www.sto.ca/index.php?id=2&L=en> Accessed: March 22, 2023

Figure 10: Existing Study Area Transit Stops

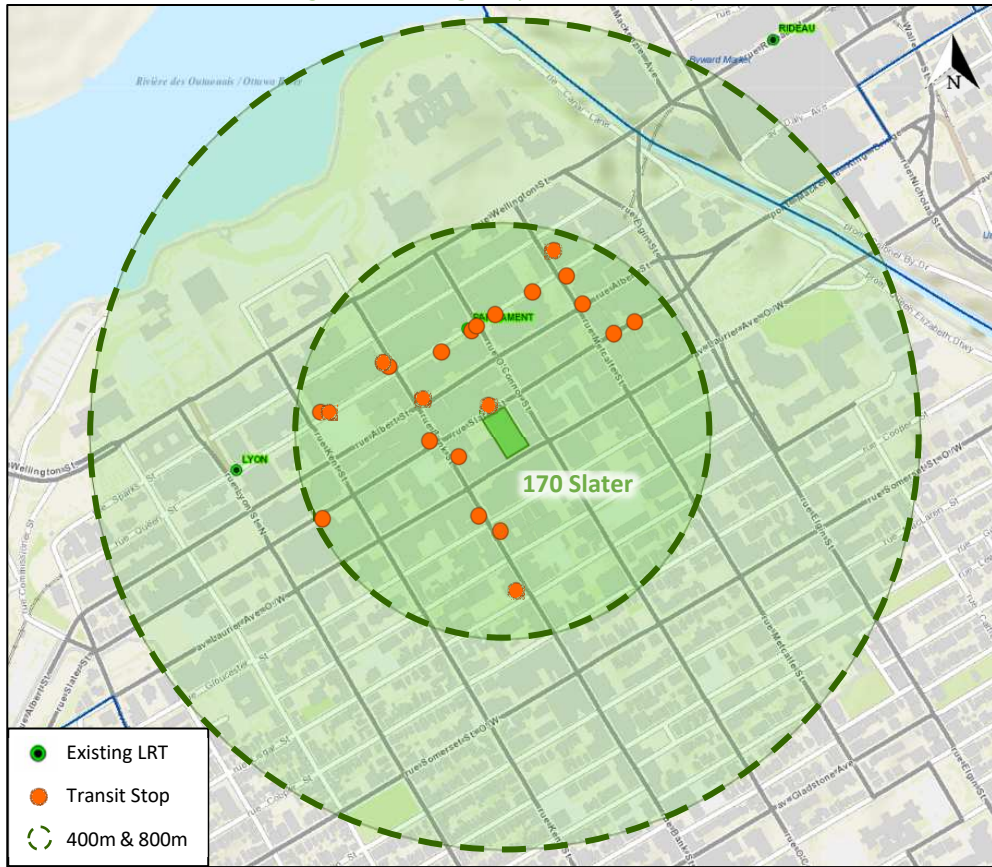

Source: <http://maps.ottawa.ca/geoOttawa/> Accessed: Feb 23, 2023

2.2.6 Existing Area Traffic Management Measures

There are no existing area traffic management measures within the study area.

2.2.7 Existing Peak Hour Travel Demand

Existing turning movement counts were acquired from the City of Ottawa and the Traffic Specialist for the existing study area intersections. Table 1 summarizes the intersection count dates and sources.

Table 1: Intersection Count Date

Intersection	Count Date	Source
Slater Street & Bank Street	Thursday, March 02, 2023	The City of Ottawa
Laurier Avenue West & Bank Street	Wednesday, April 12, 2023	The Traffic Specialist
Slater Street & O'Connor Street	Wednesday, April 12, 2023	The Traffic Specialist
Laurier Avenue West & O'Connor Street	Wednesday, April 12, 2023	The Traffic Specialist
Laurier Avenue West & Site Access #1	Wednesday, April 12, 2023	The Traffic Specialist

Figure 11 illustrates the existing traffic counts. Table 2 summarizes the existing intersection operations. The level of service for signalized intersections is based on volume to capacity ratio (v/c) calculations for individual lane movements and HCM 2000 v/c calculations for the overall intersection, and average delay for unsignalized intersections. Detailed turning movement count data is included in Appendix B and the Synchro worksheets are provided in Appendix C.

Figure 11: Existing Traffic Counts

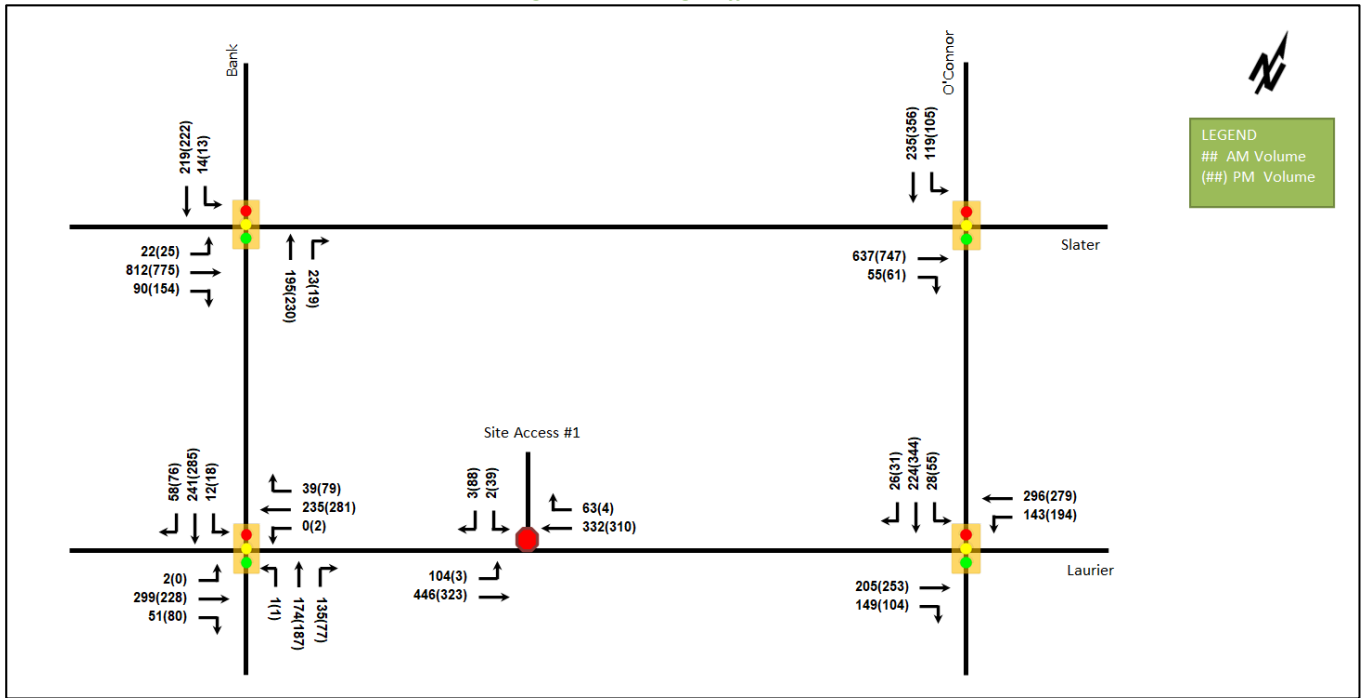

Table 2: Existing Intersection Operations

Intersection	Lane	AM Peak Hour				PM Peak Hour			
		LOS	V/C	Delay (s)	Q (95 th)	LOS	V/C	Delay (s)	Q (95 th)
Slater Street & Bank Street Signalized	EBL/T	C	0.72	19.9	73.5	B	0.66	18.4	67.6
	EBR	A	0.23	7.0	11.1	A	0.37	12.3	24.6
	NBT/R	A	0.43	12.3	m38.0	A	0.48	14.1	m21.6
	SBL/T	A	0.44	19.6	45.1	A	0.47	20.4	46.7
	Overall	B	0.61	17.8	-	A	0.60	17.3	-
Slater Street & O'Connor Street Signalized	EBT	A	0.54	2.6	3.8	A	0.54	3.8	8.2
	EBR	A	0.12	1.8	m0.7	A	0.12	3.0	m1.6
	SBL	A	0.34	13.3	20.4	A	0.33	14.2	18.8
	SBT	A	0.16	15.7	13.9	A	0.28	19.4	22.2
	Overall	A	0.42	6.7	-	A	0.44	9.0	-
Laurier Avenue West & Bank Street Signalized	EBL/T	B	0.62	26.2	64.3	A	0.42	19.4	43.9
	EBR	A	0.33	24.6	15.8	A	0.49	28.6	23.9
	WBT/R	B	0.65	42.6	68.2	C	0.78	26.2	#88.4
	NBL/T	A	0.28	12.4	27.6	A	0.31	14.4	31.9
	NBR	B	0.63	28.8	#42.5	D	0.84	80.6	#36.6
	SBL/T	A	0.39	8.4	20.1	A	0.51	13.1	34.3
	SBR	A	0.30	10.3	6.8	C	0.71	45.0	#32.4
Overall	B	0.68	23.7	-	D	0.87	24.7	-	
Laurier Avenue West & O'Connor Street Signalized	EBT/R	D	0.84	36.2	#99.0	C	0.79	27.3	m#89.8
	WBL	A	0.47	14.9	21.1	B	0.65	21.6	#30.3
	WBT	A	0.42	13.0	44.7	A	0.38	12.4	41.1
	SB	A	0.26	9.5	7.5	A	0.40	10.8	10.5
	Overall	B	0.63	20.0	-	B	0.67	17.5	-

Intersection	Lane	AM Peak Hour				PM Peak Hour			
		LOS	V/C	Delay (s)	Q (95 th)	LOS	V/C	Delay (s)	Q (95 th)
Laurier Avenue West & Site Access #1 Unsignalized	EBL/T	B	0.15	10.5	3.8	A	0.00	9.3	0.0
	WBT/R	-	-	-	-	-	-	-	-
	SBL/R	D	0.03	27.3	0.8	D	0.44	25.0	16.5
	Overall	A	-	1.3	-	A	-	4.2	-

Notes: Saturation flow rate of 1800 veh/h/lane
 Queue is measured in metres
 Peak Hour Factor = 0.90

Delay = average vehicle delay in seconds
 m = metered queue
 # = volume for the 95th %ile cycle exceeds capacity

During both peak hours, intersections within the study area operate well except for the intersections of Laurier Avenue West at Bank Street and Laurier Avenue West at O'Connor Street.

At the intersection of Laurier Avenue West at Bank Street, during both peak hours, the northbound right-turn movement may exhibit extended queues. During the PM peak, the westbound shared through/right-turn and southbound right-turn movements may exhibit extended queues. High delays may be experienced on the northbound right-turn movement during the PM peak hour.

At the intersection of Laurier Avenue West at O'Connor Street, the eastbound share through/right-turn movement during both peak hours and the westbound left-turn movement during the PM peak hour may exhibit extended queues.

2.2.8 Collision Analysis

Collision data has been acquired from the City of Ottawa open data website (data.ottawa.ca) for five years prior to the commencement of this TIA for the surrounding study area road network. Table 3 summarizes the collision types and conditions in the study area, Figure 12 illustrates the intersections and segments analyzed, and Table 4 summarizes the total collisions for each of these locations. Collision data are included in Appendix D.

Table 3: Study Area Collision Summary, 2016-2020

Total Collisions		Number	%
		126	100%
Classification	Fatality	0	0%
	Non-Fatal Injury	37	29%
	Property Damage Only	89	71%
Initial Impact Type	Approaching	1	1%
	Angle	14	11%
	Rear end	28	22%
	Sideswipe	40	32%
	Turning Movement	21	17%
	SMV Unattended	6	5%
	SMV Other	12	10%
	Other	4	3%
Road Surface Condition	Dry	87	69%
	Wet	23	18%
	Loose Snow	8	6%
	Slush	5	4%
	Packed Snow	3	2%
	Ice	0	0%
Pedestrian Involved		12	10%
Cyclists Involved		14	11%

Figure 12: Representation of Study Area Collision Records



Table 4: Summary of Collision Locations, 2016-2020

Intersections / Segments	Number	%
Laurier Ave @ O'Connor St	27	21%
Bank St @ Laurier Ave	25	20%
O'Connor St @ Slater St	24	19%
Bank St @ Slater St	22	17%
Laurier Ave W btwn Bank St & O'Connor St	17	13%
Slater St btwn Bank St & O'Connor St	10	8%
O'Connor St btwn Slater St & Laurier Ave W	1	1%

Within the study area, the intersection of Laurier Avenue West at O'Connor Street, Bank Street at Laurier Avenue West, O'Connor Street at Slater Street, and Bank Street at Slater Street are noted to have experienced higher collisions than other locations. Table 5, Table 6, Table 7, and Table 8 summarize the collision types and conditions for each location.

Table 5: Laurier Avenue West and O'Connor Street Collision Summary

Total Collisions		Number	%
Total Collisions		27	100%
Classification	Fatality	0	0%
	Non-Fatal Injury	10	37%
	Property Damage Only	17	63%
Initial Impact Type	Angle	2	7%
	Rear end	7	26%
	Sideswipe	6	22%
	Turning Movement	10	37%
	SMV Other	1	4%
	Other	1	4%
Road Surface Condition	Dry	21	78%
	Wet	1	4%
	Slush	2	7%
	Loose Snow	3	11%
Pedestrian Involved		1	4%
Cyclists Involved		7	26%

The intersection of Laurier Avenue West and O'Connor Street had a total of 27 collisions between 2016-2020, with 17 involving property damage only and the remaining ten having non-fatal injuries. The collision types are most represented by turning movement type collisions with ten collisions in this category, followed by seven rear end collisions, six sideswipe collisions, two angle collisions, and one collision each for SMV other and other type collisions. Weather conditions are not a major contributing factor to collisions at this location. No further analysis is required as part of this study.

Table 6: Bank Street at Laurier Avenue West Collision Summary

Total Collisions		Number	%
Total Collisions		25	100%
Classification	Fatality	0	0%
	Non-Fatal Injury	13	52%
	Property Damage Only	12	48%
Initial Impact Type	Angle	4	16%
	Rear end	5	20%
	Sideswipe	7	28%
	Turning Movement	6	24%
	SMV Other	3	12%
Road Surface Condition	Dry	18	72%
	Wet	5	20%
	Slush	1	4%
	Loose Snow	1	4%
Pedestrian Involved		3	12%
Cyclists Involved		6	24%

The intersection of Bank Street at Laurier Avenue West had a total of 25 collisions between 2016-2020, with 12 involving property damage only and the remaining three having non-fatal injuries. The collision types are most represented by sideswipe type collisions with seven collisions, followed by six turning movement collisions, five rear end collisions, four angle collisions, and three SMV other collisions. The collisions are distributed across the various types and no overall pattern is noted. Weather conditions are not a major contributing factor to collisions at this location. No further analysis is required as part of this study.

Table 7: O'Connor Street and Slater Street Collision Summary

		Number	%
Total Collisions		24	100%
Classification	Fatality	0	0%
	Non-Fatal Injury	5	21%
	Property Damage Only	19	79%
Initial Impact Type	Angle	4	17%
	Rear end	4	17%
	Sideswipe	9	38%
	Turning Movement	3	13%
	SMV Other	4	17%
Road Surface Condition	Dry	17	71%
	Wet	5	21%
	Loose Snow	2	8%
Pedestrian Involved		4	17%
Cyclists Involved		0	0%

The intersection of O'Connor Street and Slater Street had a total of 24 collisions between 2016-2020, with 19 involving property damage only and the remaining five having non-fatal injuries. The collision types are most represented by sideswipe type collisions with nine collisions, followed by four collisions each for angle, rear end, and SMV other type collisions, and three turning movement collisions. The collisions are distributed across the various types and no overall pattern is noted. Weather conditions are not a major contributing factor to collisions at this location. No further analysis is required as part of this study.

Table 8: Bank Street at Slater Street Collision Summary

		Number	%
Total Collisions		22	100%
Classification	Fatality	0	0%
	Non-Fatal Injury	6	27%
	Property Damage Only	16	73%
Initial Impact Type	Angle	3	14%
	Rear end	6	27%
	Sideswipe	9	41%
	Turning Movement	1	5%
	SMV Other	2	9%
	Other	1	5%
Road Surface Condition	Dry	10	45%
	Wet	8	36%
	Loose Snow	1	5%
	Slush	2	9%
	Packed Snow	1	5%
Pedestrian Involved		2	9%
Cyclists Involved		0	0%

The intersection of Bank Street at Slater Street had a total of 22 collisions between 2016-2020, with 16 involving property damage only and the remaining six having non-fatal injuries. The collision types are most represented by sideswipe type collisions with nine collisions, followed by six rear end collisions, three angle collisions, two SMV other collisions, and one collision each for turning movement and other collisions. Approximately half of collisions (12 out of 22) at this intersection happened during wet or snow-impacted road surface conditions. No further analysis is required as part of this study.

2.3 Planned Conditions

2.3.1 Changes to the Area Transportation Network

2.3.1.1 City Official Plan (2021)

Schedule C2 in the City Official Plan illustrates the Ultimate Transit Network. This diagram includes a transit priority corridor along Bank Street.

2.3.1.2 City Transportation Master Plan

The City of Ottawa's Transportation Master Plan (TMP) includes a list of proposed Active Transportation projects. The Active Transportation projects list identifies separated cycling facilities on O'Connor Street from Laurier Avenue West to Wellington Street.

2.3.2 Other Study Area Developments

208-212 Slater Street

The proposed development application includes a site plan application for a mixed-use building containing either 180 apartment units and 1,000 ft² of retail GFA or 220 hotel units and approximately 1,000 ft² of retail GFA. To provide a conservative analysis, the hotel scenario has been carried forward for the intersection analysis in the report. The development is predicted to generate 30 new AM and 27 new PM two-way peak hour auto trips. The development is assumed to be completed by 2028 and will be included in the future background horizons. (Novatech, 2021)

150, 160 Laurier Avenue West

The proposed development application includes a site plan application for a mixed-use building containing 312 residential units and 4,117 ft² of commercial retail. The development build-out and occupancy horizon is assumed to be 2027 and is predicted to generate 27 new two-way trips during the AM peak hour and 29 new two-way trips during the PM peak hour. (CGH, 2022)

84 & 100 Gloucester

The proposed development application includes a site plan application for replacing the existing seven-storey commercial/office building and the public parking lot with a total of 315 dwellings and approximately 1,550 ft² of ground-floor retail. The development build-out and occupancy horizon is assumed to be 2025. The development is predicted to generate a net decrease of 30 two-way trips during the AM peak hour and a net decrease of 38 two-way trips during the PM peak hour, and it will not be included in the future background horizons. (Novatech, 2023)

360 Laurier Avenue West

The proposed development application includes a site plan application for replacing the existing high-rise office and ground floor commercial with a total of 139 residential units and 1,405 ft² of ground-floor commercial. The development is predicted to generate a net decrease of 132 two-way trips during the AM peak hour and a net decrease of 147 two-way trips during the PM peak hour, and it will not be included in the future background horizons. (CGH, 2023)

3 Study Area and Time Periods

3.1 Study Area

The study area will include the intersections of:

- Laurier Avenue West at:
 - O’Connor Street
 - Bank Street
 - Site Access #1
- Slater Street at:
 - Bank Street
 - O’Connor Street
 - Site Access #2 (Future)
 - Site Access #3 (Future)

The boundary road will be Laurier Avenue West and Slater Street, and no screenlines are present within proximity to the site.

3.2 Time Periods

As the proposed development is a mixed-use development with residential units and commercial areas, the AM and PM peak hours will be examined.

3.3 Horizon Years

The anticipated build-out year is 2028. As a result, the full build-out plus five years horizon year is 2033.

4 Exemption Review

Table 9 summarizes the exemptions for this TIA.

Table 9: Exemption Review

Module	Element	Explanation	Exempt/Required
Design Review Component			
4.1 Development Design	4.1.2 Circulation and Access	Only required for site plans	Required
	4.1.3 New Street Networks	Only required for plans of subdivision	Exempt
4.2 Parking	4.2.1 Parking Supply	Only required for site plans	Required
	4.2.2 Spillover Parking	Only required for site plans where parking supply is 15% below unconstrained demand	Exempt
Network Impact Component			
4.5 Transportation Demand Management	All Elements	Not required for site plans expected to have fewer than 60 employees and/or students on location at any given time	Required
4.6 Neighbourhood Traffic Management	4.6.1 Adjacent Neighbourhoods	Only required when the development relies on local or collector streets for access and total volumes exceed ATM capacity thresholds	Exempt

Module	Element	Explanation	Exempt/Required
4.8 Network Concept		Only required when proposed development generates more than 200 person-trips during the peak hour in excess of equivalent volume permitted by established zoning	Required

5 Development-Generated Travel Demand

5.1 Mode Shares

Examining the mode shares recommended in the TRANS Trip Generation Manual (2020) for the subject district, derived from the most recent National Capital Region Origin-Destination survey (OD Survey), the existing average district mode shares by land use for Ottawa Centre have been summarized in Table 10.

Table 10: TRANS Trip Generation Manual Recommended Mode Shares – Ottawa Centre

Travel Mode	Multi-Unit (High-Rise)		Commercial Generator	
	AM	PM	AM	PM
Auto Driver	18%	17%	28%	19%
Auto Passenger	3%	9%	3%	12%
Transit	26%	21%	48%	30%
Cycling	1%	1%	1%	2%
Walking	52%	52%	20%	37%
Total	100%	100%	100%	100%

5.2 Trip Generation

This TIA has been prepared using the vehicle and person trip rates for the residential dwellings using the TRANS Trip Generation Manual (2020) and the vehicle trip rates and derived person trip rates for commercial component from the ITE Trip Generation Manual 11th Edition (2021) using the City-prescribed conversion factor of 1.28. Table 11 summarizes the person trip rates for the proposed residential land uses for each peak period and the person trip rates for the non-residential land uses by peak hour.

Table 11: Trip Generation Person Trip Rates

Land Use	Land Use Code	Peak Period	Vehicle Trip Rate	Person Trip Rates
Multi-Unit (High-Rise)	221 & 222 (TRANS)	AM	-	0.80
		PM	-	0.90
Land Use	Land Use Code	Peak Hour	Vehicle Trip Rate	Person Trip Rates
Strip Retail Plaza (<40k)	822 (ITE)	AM	2.36	3.02
		PM	6.59	8.44

Using the above person trip rates, the total person trip generation has been estimated. Table 12 summarizes the total person trip generation for the residential land uses and for the non-residential land uses.

Table 12: Total Person Trip Generation

Land Use	Units	AM Peak Period			PM Peak Period		
		In	Out	Total	In	Out	Total
Multi-Unit (High-Rise)	586	145	324	469	306	221	527
Land Use	GFA	AM Peak Hour			PM Peak Hour		
		In	Out	Total	In	Out	Total
Strip Retail Plaza (<40k)	8,498 sq. ft	16	10	26	36	36	72

Internal capture rates from the ITE Trip Generation Handbook 3rd Edition have been assigned to the development’s retail component for mixed-use developments. The rates summarized in Table 13 represent the percentage of trips to/from the retail use based on the residential component.

Table 13: Internal Capture Rates

Land Use	AM		PM	
	In	Out	In	Out
Residential to/from Strip Retail Plaza (<40k)	17%	14%	10%	26%

Using the above mode share targets, the internal capture, and the person trip rates, the person trips by mode have been projected. Trip generation by peak hour has been forecasted using the prescribed peak period conversion factors presented in the TRANS Trip Generation Manual (2020) for the residential component. Table 14 summarizes the residential trip generation and the non-residential trip generation by mode and peak hour.

Table 14: Trip Generation by Mode

Travel Mode		AM Peak Hour				PM Peak Hour			
		Mode Share	In	Out	Total	Mode Share	In	Out	Total
Multi-Unit (High-Rise)	Auto Driver	18%	12	28	40	17%	22	18	40
	Auto Passenger	3%	2	5	7	9%	12	9	21
	Transit	26%	20	47	67	21%	29	23	52
	Cycling	1%	1	2	3	1%	1	1	2
	Walking	52%	43	99	142	52%	80	62	142
	Total	100%	78	181	259	100%	144	113	257
Strip Retail Plaza (<40k)	Auto Driver	28%	4	3	7	19%	6	5	11
	Auto Passenger	3%	0	0	0	12%	4	3	7
	Transit	48%	7	4	11	30%	10	8	18
	Cycling	1%	0	0	0	2%	1	0	1
	Walking	20%	2	2	4	37%	12	10	22
	Internal Capture	varies	-3	-1	-4	varies	-4	-9	-13
	Total	100%	13	9	22	100%	33	26	59
Total	Auto Driver	-	15	31	46	-	28	23	51
	Auto Passenger	-	2	5	7	-	16	12	28
	Transit	-	27	51	78	-	39	31	70
	Cycling	-	1	2	3	-	2	1	3
	Walking	-	45	101	146	-	92	72	164
	Total	100%	91	190	281	100%	177	139	316

As shown above, a total of 46 AM and 51 PM new peak hour two-way vehicle trips are projected as a result of the proposed development.

5.3 Trip Distribution

To understand the travel patterns of the subject development, the OD Survey has been reviewed to determine the travel, and these patterns were applied based on the build-out of Ottawa Centre. Table 15 below summarizes the distributions.

Table 15: OD Survey Distribution – Ottawa Centre

To/From	% of Trips
North	5%
South	60%
East	20%
West	15%
Total	100%

5.4 Trip Assignment

Using the distribution outlined above, turning movement splits, and access to major transportation infrastructure, the trips generated by the site have been assigned to the study area road network. It is assumed that part of auto driver trips would be the drop off trips, and it will access to the Site Access #1 and exit from Site Access #2. The reduction from the existing site is based on the number of above-ground parking of the BMO building at 269 Laurier Avenue West and the existing turning movements. Table 16 summarizes the proportional assignment to the study area roadways. Figure 13 illustrates the new site generated volumes, Figure 14 illustrates the trip reduction from the existing site, and Figure 15 illustrates the net total volumes.

Table 16: Trip Assignment

To/From	Inbound Via	Outbound Via
North	5% O'Connor Street (N)	5% Bank Street (N)
South	20% Bank Street (S)	20% O'Connor Street (S)
	20% Laurier Avenue West (W)	20% Laurier Avenue West (W)
	20% Laurier Avenue West (E)	20% Laurier Avenue West (E)
East	20% Laurier Avenue West (E)	20% Laurier Avenue West (E)
West	15% Laurier Avenue West (W)	15% Laurier Avenue West (W)
Total	100%	100%

Figure 13: New Site Generation Auto Volumes

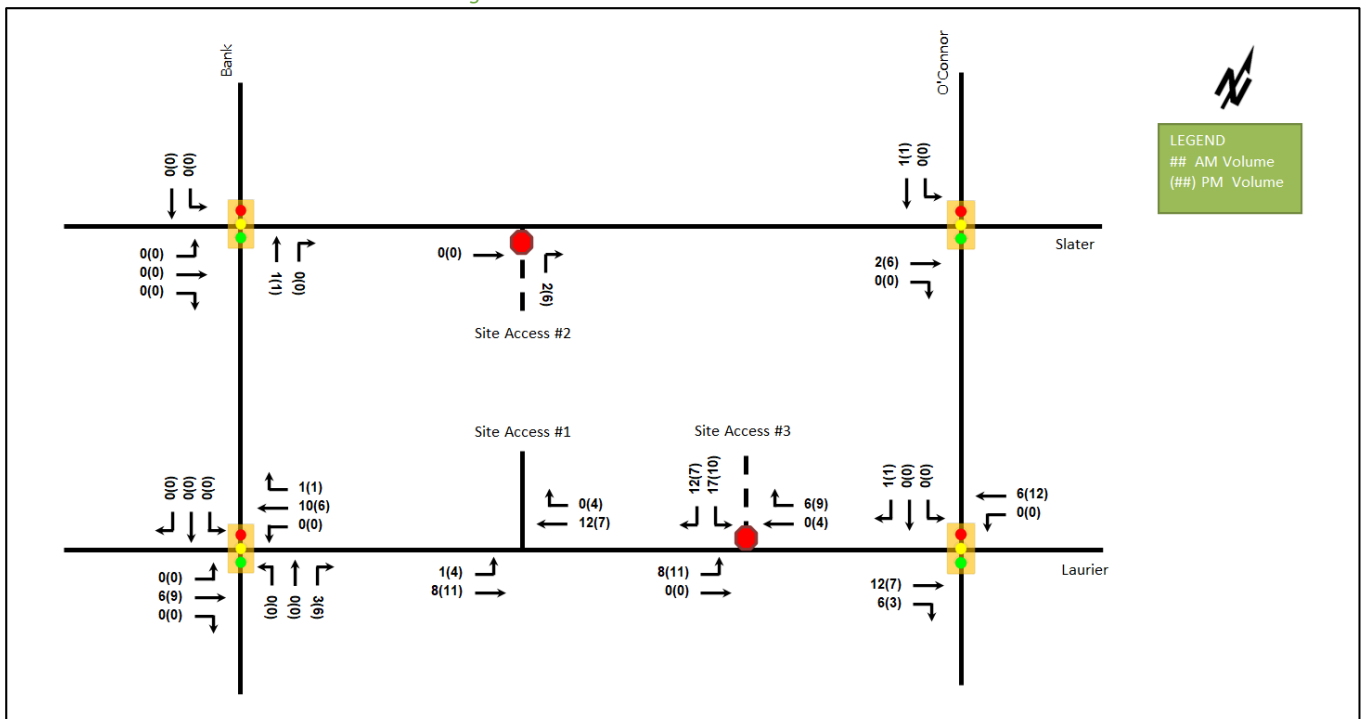

Figure 14: Reduction from the Existing Site

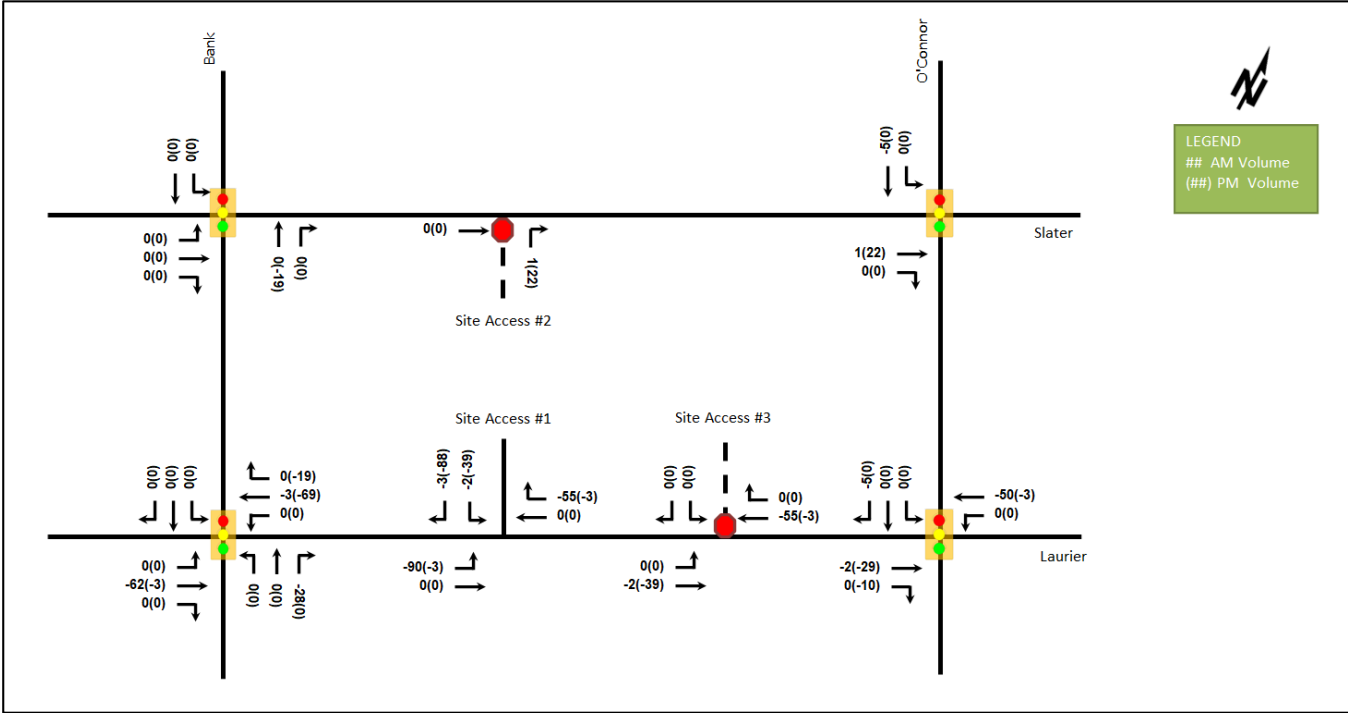
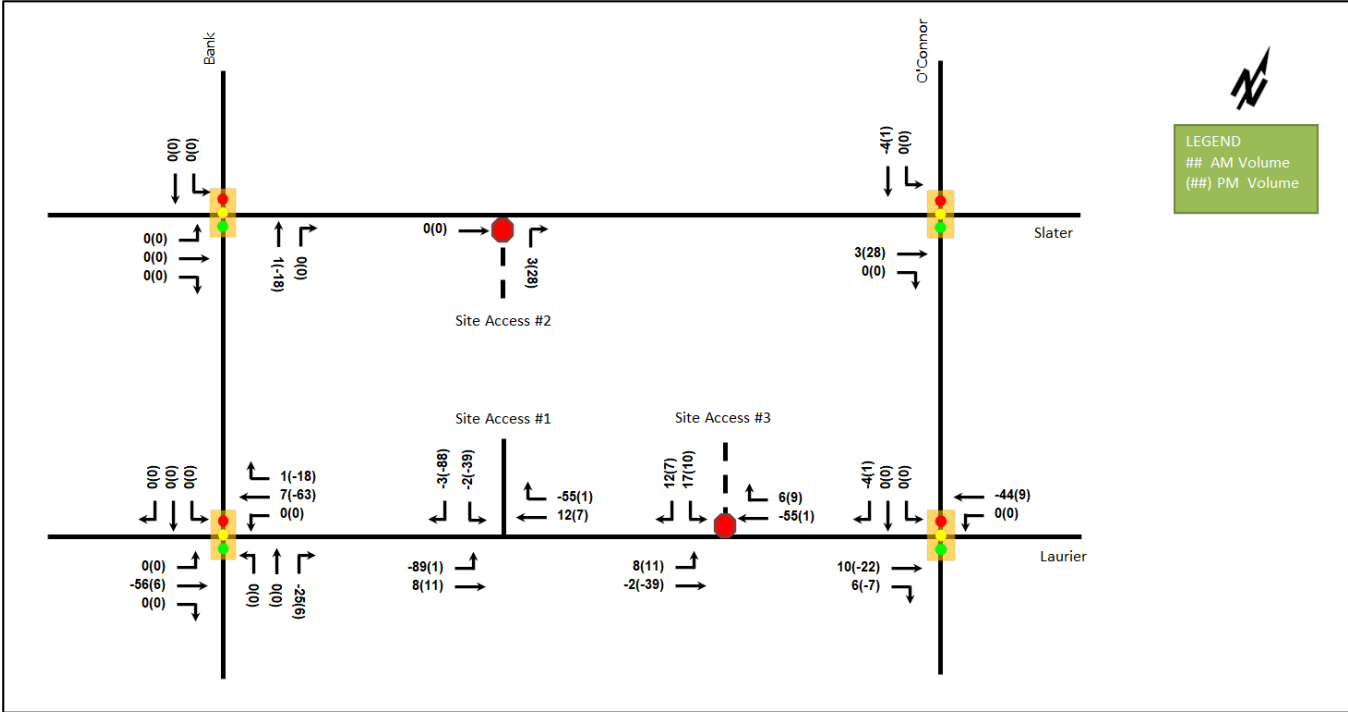

Figure 15: Net Total Volumes



6 Background Network Travel Demands

6.1 Transportation Network Plans

The transportation network plans were discussed in Section 2.3 and have been incorporated into the road network analysis.

6.2 Background Growth

A review of the background projections from the City’s TRANS Regional Model for the 2011 and 2031 horizons was completed to determine the background growth for each of the study area roadways. The background TRANS model growth rates are summarized in Table 17 and the TRANS model plots are provided in Appendix E.

Table 17: TRANS Regional Model Projections – Study Area Growth Rates

Street	TRANS Rate	
	Eastbound	Westbound
Laurier	-2.09%	-1.44%
Slater	3.91%	-
	Northbound	Southbound
O’Connor	-	-0.31%
Bank	1.13%	4.74%

It is noted that any negative growth have not been used, as this would result in a reduction in traffic volumes. As a conservative estimate a growth rate of 0% will be applied on Laurier Avenue West and O’Connor Street.

TRANS Rates along Slater Street and Bank Street are noted to be high and unsustainable for downtown Ottawa. The City of Ottawa map illustrating the AM peak period intersection traffic growth rate between 2000 and 2016 was reviewed to gain further insights on historical growth trend lines in the study area. This map shows contraction rates of -2% to -0.2% for at all study area intersection volumes. Therefore, a conservative growth rate of 1.00% will be applied to the mainline volumes on Bank Street and Slater Street. The 2000-2016 intersection traffic growth rate map has been provided in Appendix F.

Table 18 summarizes the recommended growth rates to be considered within the study area..

Table 18: Recommended Area Growth Rates

Street	Peak Hour	
	Eastbound	Westbound
Laurier	0%	0%
Slater	1.00%	-
	Northbound	Southbound
O’Connor	-	0%
Bank	1.00%	1.00%

6.3 Other Developments

The background developments explicitly considered in the background conditions (Section 6.2) include:

- 208-212 Slater Street
- 150, 160 Laurier Avenue West

Figure 16 illustrates the background developments volumes. The background development volumes within the study area have been provided in Appendix G.

Figure 16: Background developments volumes

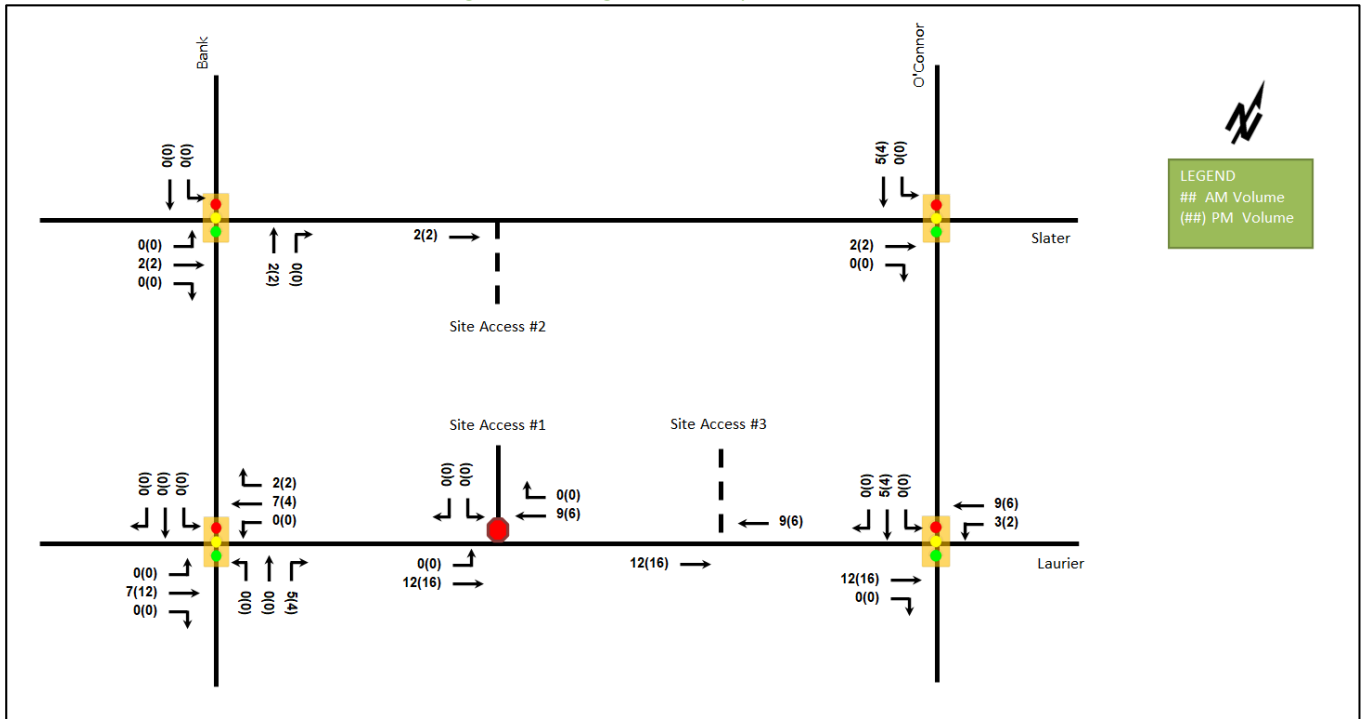

7 Demand Rationalization

7.1 2028 Future Background Operations

Figure 17 illustrates the 2027 background volumes and Table 19 summarizes the 2028 background intersection operations. The level of service for signalized intersections is based on v/c calculations for individual lane movements and HCM 2000 v/c calculations for the overall intersection, and average delay for unsignalized intersections. The Synchro worksheets for the 2028 future background horizon are provided in Appendix H.

Figure 17: 2028 Future Background Volumes

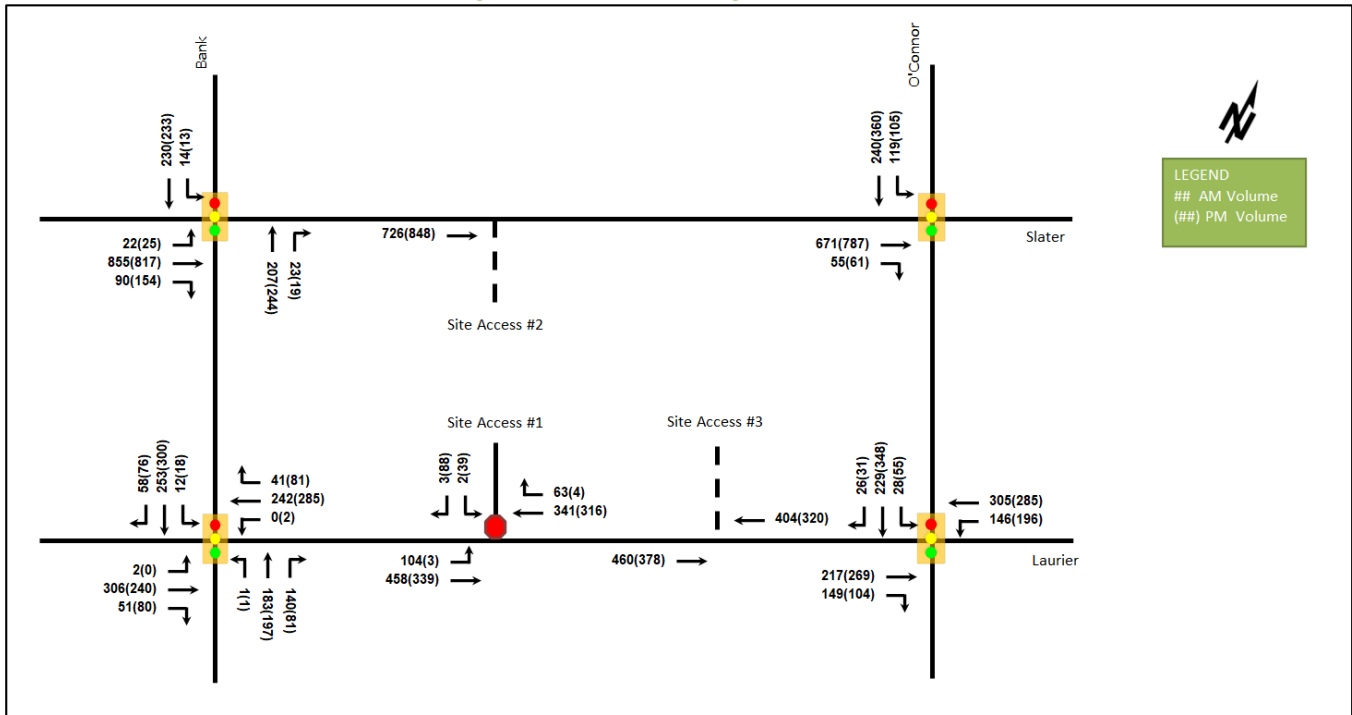

Table 19: 2028 Future Background Intersection Operations

Intersection	Lane	AM Peak Hour				PM Peak Hour			
		LOS	V/C	Delay (s)	Q (95 th)	LOS	V/C	Delay (s)	Q (95 th)
Slater Street & Bank Street Signalized	EBL/T	B	0.68	18.9	68.1	B	0.62	17.6	62.7
	EBR	A	0.20	6.2	9.3	A	0.33	11.2	21.4
	NBT/R	A	0.41	12.0	24.4	A	0.46	13.6	m20.9
	SBL/T	A	0.41	19.1	42.2	A	0.44	19.9	43.8
	Overall	A	0.57	17.0	-	A	0.57	16.6	-
Slater Street & O'Connor Street Signalized	EBT	A	0.51	2.4	3.5	A	0.52	3.7	7.7
	EBR	A	0.11	1.7	m0.6	A	0.11	2.9	m1.5
	SBL	A	0.30	11.6	17.1	A	0.29	12.0	15.6
	SBT	A	0.15	15.6	12.9	A	0.26	19.2	20.2
	Overall	A	0.39	6.3	-	A	0.42	8.6	-
Laurier Avenue West & Bank Street Signalized	EBL/T	A	0.57	24.9	58.5	A	0.39	19.0	41.5
	EBR	A	0.29	23.5	14.2	A	0.44	26.4	21.2
	WBT/R	A	0.60	41.2	63.7	C	0.72	22.4	#40.6
	NBL/T	A	0.27	12.2	26.1	A	0.29	14.2	30.1
	NBR	A	0.59	26.0	#38.6	C	0.79	71.5	#34.5
	SBL/T	A	0.37	8.1	18.6	A	0.48	12.5	31.8
	SBR	A	0.27	9.7	6.0	B	0.64	38.1	#29.9
Overall	B	0.63	22.6	-	D	0.81	22.3	-	
Laurier Avenue West & O'Connor Street Signalized	EBT/R	C	0.78	30.9	#88.4	C	0.74	23.1	m#82.1
	WBL	A	0.41	13.4	19.5	A	0.56	17.4	25.6
	WBT	A	0.39	12.6	41.1	A	0.35	12.0	37.3
	SB	A	0.24	9.4	6.9	A	0.36	10.7	9.8
	Overall	A	0.58	18.0	-	B	0.62	15.6	-

Intersection	Lane	AM Peak Hour				PM Peak Hour			
		LOS	V/C	Delay (s)	Q (95 th)	LOS	V/C	Delay (s)	Q (95 th)
Laurier Avenue West & Site Access #1 Unsignalized	EBL/T	B	0.13	10.2	3.0	A	0.00	9.2	0.0
	WBT/R	-	-	-	-	-	-	-	-
	SBL/R	C	0.03	24.5	0.8	C	0.38	22.2	12.8
	Overall	A	-	1.2	-	A	-	3.6	-

Notes: Saturation flow rate of 1800 veh/h/lane
Queue is measured in metres
Peak Hour Factor = 1.00

Delay = average vehicle delay in seconds
m = metered queue
= volume for the 95th %ile cycle exceeds capacity

During both the AM and PM peak hours, intersections within the study area will operate similar to existing condition with minor improvements to the intersection operations, due to the adjustment of the peak hour factor to 1.00 for forecasted conditions. No capacity issues are noted.

7.2 2033 Future Background Operations

Figure 18 illustrates the 2033 background volumes and Table 20 summarizes the 2033 background intersection operations. The level of service for signalized intersections is based on v/c calculations for individual lane movements and HCM 2000 v/c calculations for the overall intersection, and average delay for unsignalized intersections. The Synchro worksheets for the 2033 future background horizon are provided in Appendix I.

Figure 18: 2033 Future Background Volumes

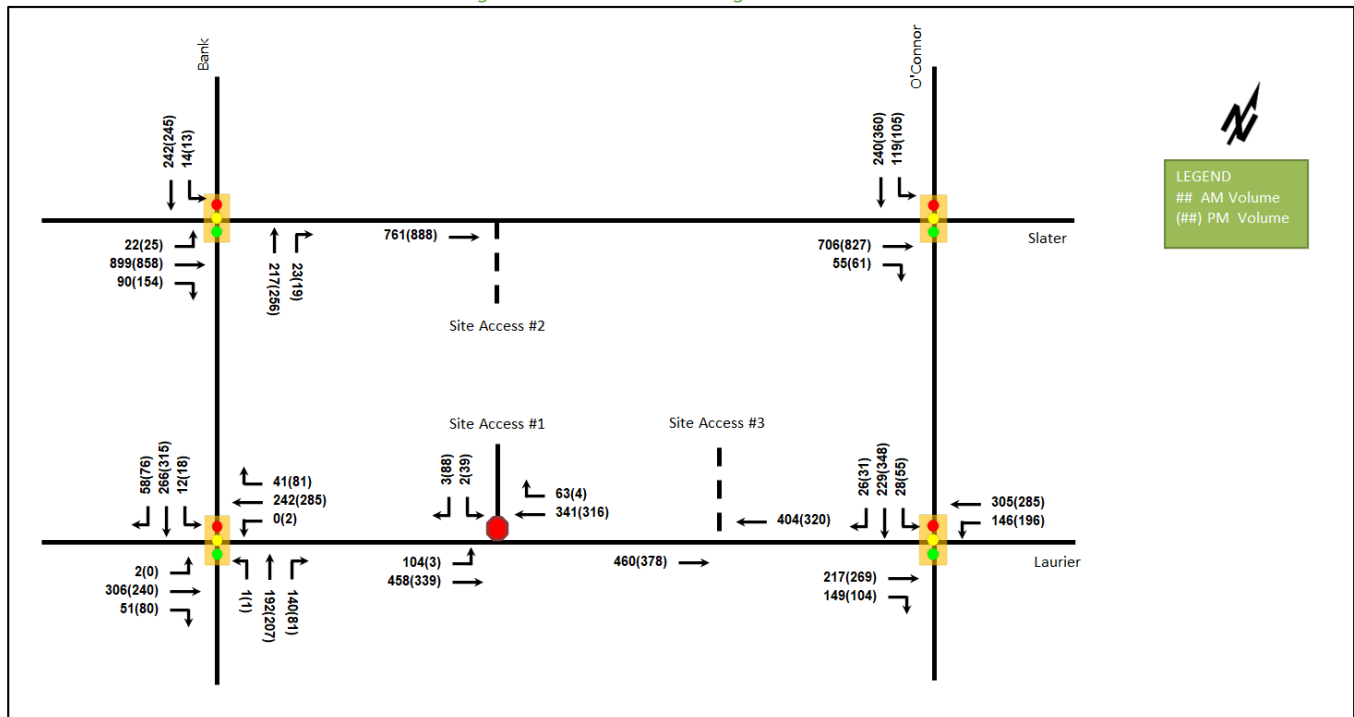

Table 20: 2033 Future Background Intersection Operations

Intersection	Lane	AM Peak Hour				PM Peak Hour			
		LOS	V/C	Delay (s)	Q (95 th)	LOS	V/C	Delay (s)	Q (95 th)
Slater Street & Bank Street Signalized	EBL/T	C	0.71	19.8	72.8	B	0.65	18.2	66.9
	EBR	A	0.20	6.4	9.6	A	0.33	11.4	21.6
	NBT/R	A	0.43	12.2	31.0	A	0.48	13.7	m21.1
	SBL/T	A	0.43	19.4	44.4	A	0.46	20.3	46.0
	Overall	A	0.60	17.7	-	A	0.59	17.1	-

Intersection	Lane	AM Peak Hour				PM Peak Hour			
		LOS	V/C	Delay (s)	Q (95 th)	LOS	V/C	Delay (s)	Q (95 th)
Slater Street & O'Connor Street Signalized	EBT	A	0.54	2.4	3.5	A	0.54	3.7	8.0
	EBR	A	0.11	1.6	m0.6	A	0.11	2.9	m1.4
	SBL	A	0.31	12.4	17.9	A	0.30	12.9	16.4
	SBT	A	0.15	15.6	12.9	A	0.26	19.2	20.2
	Overall	A	0.41	6.3	-	A	0.43	8.5	-
Laurier Avenue West & Bank Street Signalized	EBL/T	A	0.57	24.9	58.5	A	0.39	19.0	41.5
	EBR	A	0.29	23.5	14.2	A	0.44	26.4	21.2
	WBT/R	A	0.60	41.2	63.7	C	0.72	22.4	#40.6
	NBL/T	A	0.28	12.4	27.4	A	0.30	14.4	31.7
	NBR	A	0.59	26.0	#38.6	C	0.79	71.5	#34.5
	SBL/T	A	0.39	8.1	18.9	A	0.50	12.6	32.7
	SBR	A	0.27	9.7	6.0	B	0.64	37.7	#29.4
Overall	B	0.63	22.4	-	D	0.81	22.2	-	
Laurier Avenue West & O'Connor Street Signalized	EBT/R	C	0.78	30.9	#88.4	C	0.74	23.1	m#82.1
	WBL	A	0.41	13.4	19.5	A	0.56	17.4	25.6
	WBT	A	0.39	12.6	41.1	A	0.35	12.0	37.3
	SB	A	0.24	9.3	6.9	A	0.36	10.6	9.6
	Overall	A	0.58	18.0	-	B	0.62	15.6	-
Laurier Avenue West & Site Access #1 Unsignalized	EBL/T	B	0.13	10.2	3.0	A	0.00	9.2	0.0
	WBT/R	-	-	-	-	-	-	-	-
	SBL/R	C	0.03	24.5	0.8	C	0.38	22.2	12.8
	Overall	A	-	1.2	-	A	-	3.6	-

Notes: Saturation flow rate of 1800 veh/h/lane
Queue is measured in metres
Peak Hour Factor = 1.00

Delay = average vehicle delay in seconds
m = metered queue
= volume for the 95th %ile cycle exceeds capacity

During both the AM and PM peak hours, intersections within the study area are projected to operate with similar operational characteristics to the 2028 future background conditions. No capacity issues are noted.

7.3 2028 Future Total Operations

Figure 19 illustrates the 2028 future total volumes and Table 21 summarizes the 2028 future total intersection operations. The level of service for signalized intersections is based on HCM 2010 calculations for individual lane movements and HCM 2000 v/c calculations for the overall intersection, and HCM average delay for unsignalized intersections. The Synchro worksheets for the 2028 future total horizon are provided in Appendix J.

Figure 19: 2028 Future Total Volumes

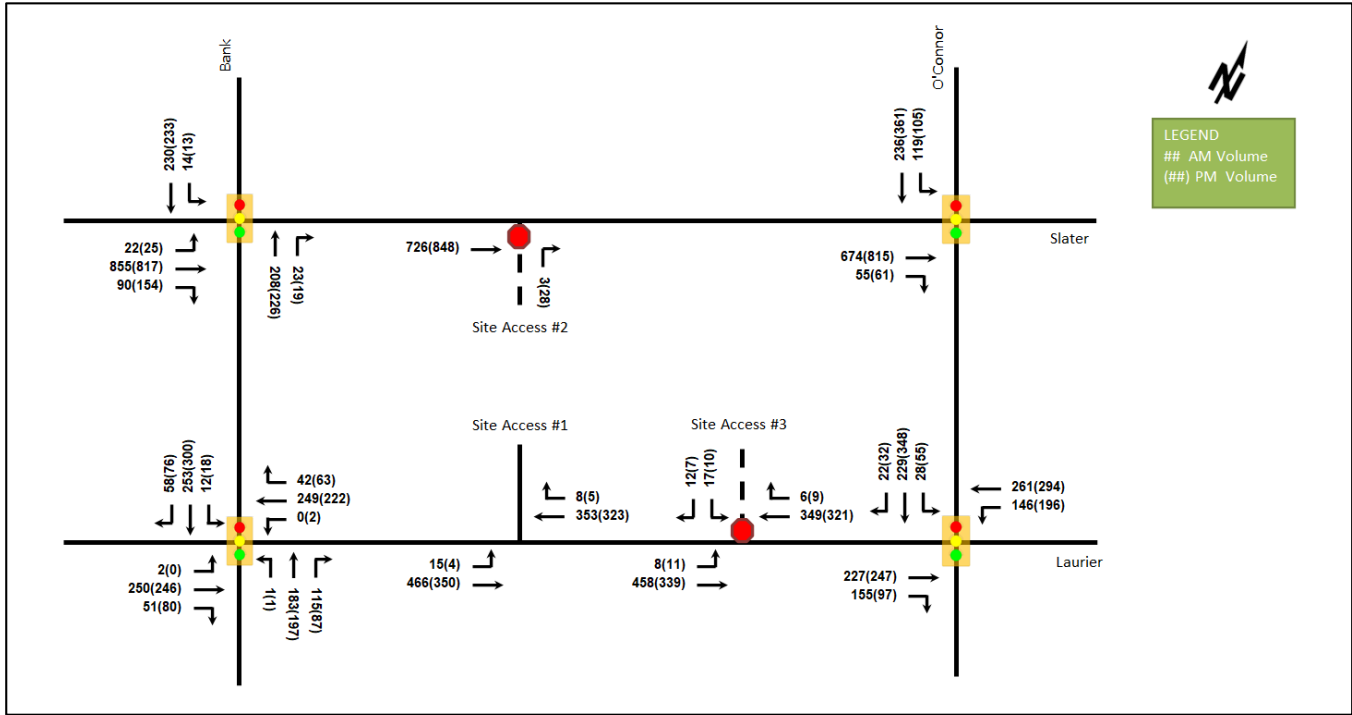

Table 21: 2028 Future Total Intersection Operations

Intersection	Lane	AM Peak Hour				PM Peak Hour			
		LOS	V/C	Delay (s)	Q (95 th)	LOS	V/C	Delay (s)	Q (95 th)
Slater Street & Bank Street Signalized	EBL/T	B	0.68	18.9	68.1	B	0.62	17.6	62.7
	EBR	A	0.20	6.2	9.3	A	0.33	11.2	21.4
	NBT/R	A	0.41	12.0	24.5	A	0.43	11.7	17.4
	SBL/T	A	0.41	19.1	42.2	A	0.44	19.9	43.8
	Overall	A	0.57	17.0	-	A	0.56	16.3	-
Slater Street & O'Connor Street Signalized	EBT	A	0.51	2.5	3.6	A	0.53	4.0	8.8
	EBR	A	0.11	1.7	m0.6	A	0.11	3.1	m1.6
	SBL	A	0.30	11.6	17.1	A	0.30	12.8	16.3
	SBT	A	0.15	15.6	12.7	A	0.26	19.2	20.3
	Overall	A	0.39	6.3	-	A	0.43	8.7	-
Laurier Avenue West & Bank Street Signalized	EBL/T	A	0.46	22.5	47.1	A	0.40	19.2	42.7
	EBR	A	0.29	23.5	14.2	A	0.44	26.4	21.2
	WBT/R	B	0.62	40.6	64.5	A	0.56	15.8	25.1
	NBL/T	A	0.27	12.2	26.1	A	0.29	14.2	30.1
	NBR	A	0.48	21.0	25.7	D	0.85	82.6	#36.9
	SBL/T	A	0.37	8.1	18.6	A	0.48	12.5	31.8
	SBR	A	0.27	9.7	6.0	B	0.64	38.1	#29.9
	Overall	A	0.57	21.4	-	C	0.76	21.8	-
Laurier Avenue West & O'Connor Street Signalized	EBT/R	D	0.81	34.3	#94.1	B	0.68	19.8	m69.0
	WBL	A	0.43	13.8	19.5	A	0.53	16.1	25.6
	WBT	A	0.33	11.9	34.5	A	0.36	12.2	38.6
	SB	A	0.24	9.4	6.8	A	0.36	10.7	9.9
	Overall	A	0.58	19.5	-	A	0.59	14.4	-

Intersection	Lane	AM Peak Hour				PM Peak Hour			
		LOS	V/C	Delay (s)	Q (95 th)	LOS	V/C	Delay (s)	Q (95 th)
Laurier Avenue West & Site Access #1 Unsignalized	EBL/T	Low volumes do not return operational results.							
	WBT/R								
	Overall								
Slater Street & Site Access #2 Unsignalized	EBT	-	-	-	-	-	-	-	-
	NBR	B	0.01	10.7	0.0	B	0.05	11.5	1.5
	Overall	A	-	0.0	-	A	-	0.4	-
Laurier Avenue West & Site Access #3 Unsignalized	EBL/T	A	0.01	9.4	0.0	A	0.01	9.3	0.0
	WBT/R	-	-	-	-	-	-	-	-
	SBL/R	C	0.13	23.1	3.0	C	0.06	19.3	1.5
	Overall	A	-	0.9	-	A	-	0.6	-

Notes: Saturation flow rate of 1800 veh/h/lane
 Queue is measured in metres
 Peak Hour Factor = 1.00
 Delay = average vehicle delay in seconds
 m = metered queue
 # = volume for the 95th %ile cycle exceeds capacity

During both the AM and PM peak hours, intersection operations within the study area are projected to improve due to the reduction in traffic volumes projected as a result of the redevelopment of the subject site. No capacity issues are noted during both peak hours at the 2028 future total horizon.

At the intersection of Laurier Avenue West at Bank Street during the PM peak, the northbound right-turn and southbound right-turn movements may exhibit extended queues, and high delays may be experienced on the northbound right-turn movement. These are similar to the existing condition.

At the intersection of Laurier Avenue West at O’Connor Street, the eastbound share through/right-turn movement during the AM peak hour may exhibit extended queues, and this is similar to the existing condition.

The access intersections are projected to operate well.

7.4 2033 Future Total Operations

Figure 20 illustrates the 2033 future total volumes and Table 22 summarizes the 2033 future total intersection operations. The level of service for signalized intersections is based on HCM 2010 calculations for individual lane movements and HCM 2000 v/c calculations for the overall intersection, and HCM average delay for unsignalized intersections. The Synchro worksheets for the 2033 future total horizon are provided in Appendix K.

Figure 20: 2033 Future Total Volumes

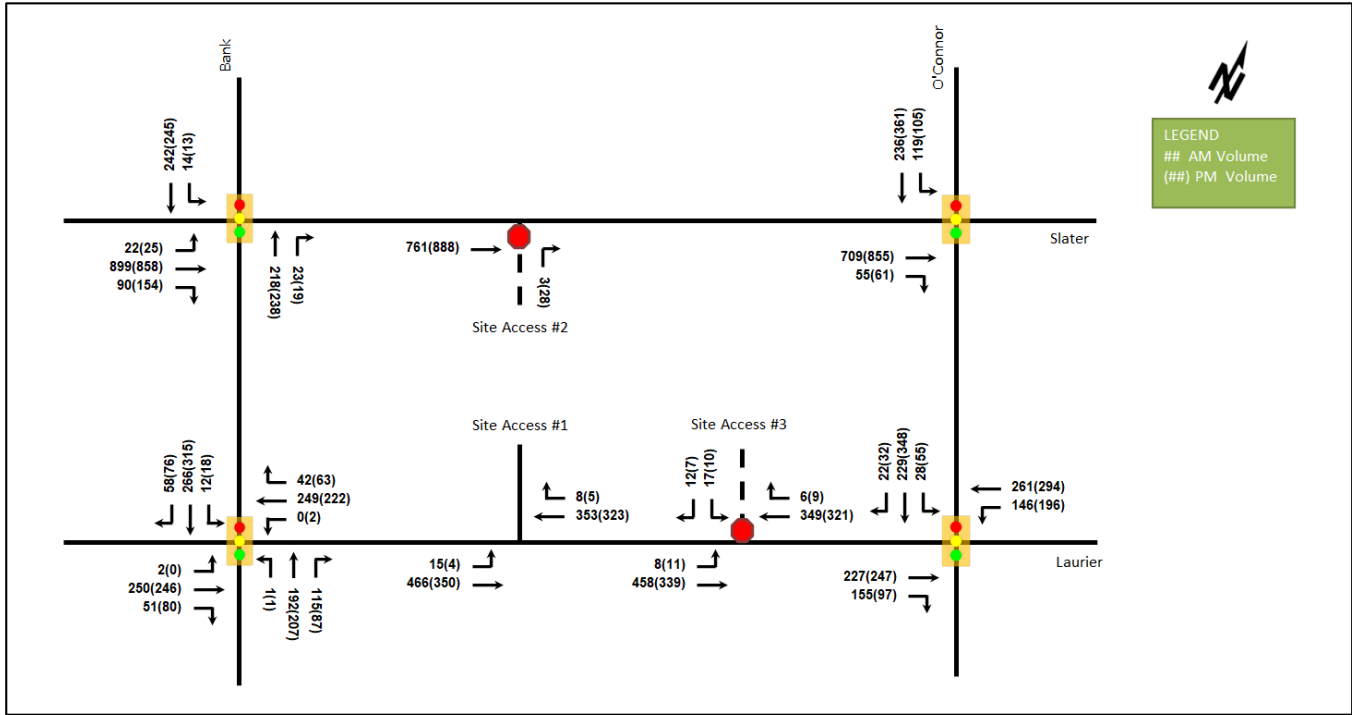

Table 22: 2033 Future Total Intersection Operations

Intersection	Lane	AM Peak Hour				PM Peak Hour			
		LOS	V/C	Delay (s)	Q (95 th)	LOS	V/C	Delay (s)	Q (95 th)
Slater Street & Bank Street Signalized	EBL/T	C	0.71	19.8	72.8	B	0.65	18.2	66.9
	EBR	A	0.20	6.4	9.6	A	0.33	11.4	21.6
	NBT/R	A	0.43	12.3	34.6	A	0.45	11.9	17.6
	SBL/T	A	0.43	19.4	44.4	A	0.46	20.3	46.0
	Overall	A	0.60	17.7	-	A	0.58	16.8	-
Slater Street & O'Connor Street Signalized	EBT	A	0.54	2.5	3.7	A	0.56	4.0	9.0
	EBR	A	0.11	1.7	m0.7	A	0.11	3.1	m1.5
	SBL	A	0.31	12.4	17.9	A	0.30	13.6	16.9
	SBT	A	0.15	15.6	12.7	A	0.26	19.2	20.3
	Overall	A	0.41	6.3	-	A	0.44	8.7	-
Laurier Avenue West & Bank Street Signalized	EBL/T	A	0.46	22.3	46.1	A	0.40	19.2	42.7
	EBR	A	0.29	23.5	14.2	A	0.44	26.4	21.2
	WBT/R	B	0.61	40.1	63.1	A	0.56	15.8	25.1
	NBL/T	A	0.28	12.4	27.4	A	0.30	14.4	31.7
	NBR	A	0.48	21.0	25.7	D	0.85	82.6	#36.9
	SBL/T	A	0.39	8.1	18.9	A	0.50	12.6	32.7
	SBR	A	0.27	9.7	6.0	B	0.64	37.7	#29.4
	Overall	A	0.57	21.0	-	C	0.76	21.7	-
Laurier Avenue West & O'Connor Street Signalized	EBT/R	D	0.81	34.5	#94.2	B	0.68	19.8	m69.0
	WBL	A	0.43	13.8	19.5	A	0.53	16.1	25.6
	WBT	A	0.33	11.9	34.5	A	0.36	12.2	38.6
	SB	A	0.24	9.3	6.8	A	0.36	10.7	9.7
	Overall	A	0.58	19.5	-	A	0.59	14.3	-

Intersection	Lane	AM Peak Hour				PM Peak Hour			
		LOS	V/C	Delay (s)	Q (95 th)	LOS	V/C	Delay (s)	Q (95 th)
Laurier Avenue West & Site Access #1 Unsignalized	EBL/T	Low volumes do not return operational results.							
	WBT/R								
	Overall								
Slater Street & Site Access #2 Unsignalized	EBT	-	-	-	-	-	-	-	-
	NBR	B	0.01	10.9	0.0	B	0.05	11.8	1.5
	Overall	A	-	0.0	-	A	-	0.4	-
Laurier Avenue West & Site Access #3 Unsignalized	EBL/T	A	0.01	9.4	0.0	A	0.01	9.3	0.0
	WBT/R	-	-	-	-	-	-	-	-
	SBL/R	C	0.13	23.1	3.0	C	0.06	19.3	1.5
	Overall	A	-	0.9	-	A	-	0.6	-

Notes: Saturation flow rate of 1800 veh/h/lane
Queue is measured in metres
Peak Hour Factor = 1.00

Delay = average vehicle delay in seconds
m = metered queue
= volume for the 95th %ile cycle exceeds capacity

During both the AM and PM peak hours, intersection operations within the study area are projected to improve due to the reduction in traffic volumes projected as a result of the redevelopment of the subject site. No capacity issues are noted during both peak hours during the 2033 future total horizon.

At the intersection of Laurier Avenue West at Bank Street during the PM peak, the northbound right-turn and southbound right-turn movements may exhibit extended queues, and high delays may be experienced on the northbound right-turn movement. These are similar to the existing condition.

At the intersection of Laurier Avenue West at O’Connor Street, the eastbound share through/right-turn movement during the AM peak hour may exhibit extended queues, and this is similar to the existing and 2028 future total conditions.

The access intersections are projected to operate well .

7.4.1 Network Rationalization

No capacity issues are noted at intersections within the study area for both existing and background conditions. No rationalization of background travel demand is required for this study.

7.4.2 Development Rationalization

The mode shares used within the TIA represent the unmodified district mode shares for Ottawa Centre. The selected mode shares and resultant site trip generation was found to have minor impacts to the network. No capacity issues are noted at intersections within the study area at future total horizons, and no rationalization for site traffic or modal share selection is required.

8 Development Design

8.1 Design for Sustainable Modes

The proposed development is a mixed-use building with residential and ground floor commercial/retail, with parking provided in two underground levels. Bicycle parking is provided both external and internal to the building. Sixteen external bicycle parking spaces and 277 internal bike parking are provided. Two pedestrian pick-up / drop-off areas are proposed along the laneway between Laurier Avenue West and Slater Street, encouraging shared mobility travel choices such as taxi and Uber. Pedestrian and cycling facilities are provided along the boundary streets, as discussed in Section 2.2.4. Additionally, through this redevelopment, a 1.8-meter-wide pedestrian

walkway is proposed along the laneway between Slater Street and Laurier Avenue West. This walkway will enable pedestrian City block permeability, creating more direct pedestrian connections for pedestrians in the study area. The infrastructure TDM Checklist is provided in Appendix L.

8.2 Circulation and Access

The development includes one existing full movement access to Laurier Avenue West (Site Access #1), which will be converted to an inbound only access and will connect to Slater Street (Site Access #2) for outbound movements only, and one proposed full movement access to Laurier Avenue West (Site Access #3).

Site Access #1 is an existing shared laneway on Laurier Avenue West between 170 Slater Street and 269 Laurier Avenue West, and it is proposed to be converted to one-way only, with in-only access at Laurier Avenue West, and out-only access at Slater Street (Site Access #2). A signage plan was prepared to indicate one-way circulation at this laneway and can be found in Appendix M. The one-way access pavement is proposed to be approximately 5.0 metres wide at its most narrow section, with passenger pick-up / drop-off areas and pedestrian walkway located on the east side of the laneway, and access to 269 Laurier Avenue West surface parking to the west.

Site Access #3 is a new full-movement two-way access on Laurier Avenue West. It is approximately 6.0 metres wide in its most narrow section, and it connects to the loading area and the underground parking.

Garbage collection as well as oversized commercial and residential loading is anticipated to take place within the ground floor loading dock area. There are also two residential loading areas located at P1 level. Emergency services are anticipated to access the site via the boundary roads. An HSU was tested as the design vehicle for the ground floor garbage, commercial and residential loading. The underground residential loading areas were tested using an LSU as the design vehicle. All horizontal turning paths can be accommodated by the proposed site plan layout. Turning templates are provided in Appendix N. The ramp grades have been determined by others and have not been reviewed by CGH.

The vehicle parking requirements and provisions for the proposed development are summarized in Table 23.

Table 23: Auto Parking Provisions

Land Use / Area	Requirement	Units / GFA	Parking Rate	Parking Required	Parking Provided
Dwelling Unit / Central Area	Minimum	586	0	0	130 resident + 30 visitor
	Visitor		0.1 per dwelling unit after first 12 units, but no more than thirty	30	
	Maximum		1.5 per dwelling unit (combined total of resident and visitor parking)	879	
Retail Store / Central Area	Minimum	789.5	0	0	0
	Maximum	sq. m	1 per 100 m ² of gross floor area	8	

Based on the City of Ottawa Zoning By-Law 2008-250, a minimum of 30 residential visitor parking spaces, a maximum of 867 residential parking spaces, and a maximum of eight retail parking spaces are permitted at the proposed development. The proposed site plan includes 130 resident parking spaces, 30 visitor parking spaces and zero retail parking spaces. The maximum residential parking and minimum visitor parking requirements are satisfied.

The bicycle parking requirements and provisions for the proposed development are summarized in Table 24.

Table 24: Bicycle Parking Provisions

Land Use / Area	Requirement	Units / GFA	Parking Rate	Parking Required	Parking Provided
Dwelling Unit / Central Area	Minimum	578	0.50 per dwelling unit	289	277 inside 16 outside
Retail Store / Central Area	Minimum	804 sq. m	1 per 250 m ² of gross floor area	4	
Total:				293	293

The City of Ottawa Zoning By-Law 2008-250 requires a minimum of 289 resident bicycle parking spaces and four retail bicycle parking space. The proposed site plan includes 277 internal bicycle parking spaces and 16 external parking spaces, which is in line with the parking requirements.

9 Boundary Street Design

Table 25 summarizes the MMLOS analysis for the boundary streets of Laurier Avenue West. The existing and future conditions for both streets will be the same and are considered in one row. The boundary street analysis is based on the policy area of “Within 600 m of a rapid transit station” and the land-use area of “Central Area”. The MMLOS worksheets has been provided in Appendix O.

Table 25: Boundary Street MMLOS Analysis

Segment	Pedestrian LOS		Bicycle LOS		Transit LOS		Truck LOS	
	PLOS	Target	BLOS	Target	TLOS	Target	TrLOS	Target
Laurier Avenue West	B	A	A	A	-	-	C	D
Slater Street	C	A	E	C	-	-	A	D

Laurier Avenue West and Slater Street do not meet the pedestrian MMLOS targets. To achieve the target LOS A, Slater Street would either require on-street parking to separate pedestrians from vehicular traffic, or a posted speed of 30 km/h or lower.

Slater Street does not meet the bicycle MMLOS targets. A target LOS of C would either require a physical separation from vehicular traffic or a posted speed of 40 km/h or lower.

The City may look at reducing the speed limit or implementing physical measures to separate pedestrians and cyclists from vehicular traffic to help improve the PLOS and BLOS results.

10 Access Intersections Design

10.1 Location and Design of Access

The development includes one existing full movement access to Laurier Avenue West (Site Access #1), which will be converted to an inbound only access and connects to Slater Street (Site Access #2) for egress only, and one proposed full movement access to Laurier Avenue West (Site Access #3).

Site Access #1 is an existing shared laneway on Laurier Avenue West between 170 Slater Street and 269 Laurier Avenue West, and it is proposed to be converted to one-way only, with in-only access at Laurier Avenue West, and out-only at Slater Street access (Site Access #2). A signage plan was prepared to indicate one-way circulation at this laneway and can be found in Appendix M. The one-way access is proposed to be approximately 5.0 meters wide at its most narrow section and 6.2 metres wide along the Laurier Avenue West sidewalk.

Site Access #3 is a new full-movement access on Laurier Avenue West, and the width is approximately 6.0 meters at its most narrow section and 8.0 metres along the Laurier Avenue West sidewalk. The throat length for the Site

Access #3 is approximately 5.7 metres measured from the edge of the sidewalk to the garage door, and the distance from edge of the sidewalk to the first conflict point within the internal drive aisle is 31.5 metres. According to TAC (2017), the minimum throat length requirement for an access from an apartment building with over 200 units to an arterial road is 40 metres.

When reviewing the TAC throat length requirement, it is important to note the context under which this requirement was established. For apartments, the throat length requirement varies depending on the number of units provided. However, the TAC requirement does not take into account the projected mode shares at a given site. The apartment building with an auto mode share of 100% will have a significantly larger traffic demand, when compared to the proposed development with a projected auto mode shares ranging between 17% and 28%. As outlined in Figure 15, the maximum hourly number of inbound trips expected at the proposed development is 20, or an equivalent of one car arrival per every three minutes. Thus, a throat length requirement of 40 meters is likely excessive given the expected arrival rate. Further, it is important to note the urban context in the study area, where driving speeds are lower due to auto, pedestrian, and bicycle traffic in combination with shorter block distances and other urban environment constraints. When driving in these conditions, drivers anticipate slow moving / stopped vehicles in downtown core, when compared to driving on free flow arterial roads. Lastly, modern access key fob technology enables the drivers to open the gate remotely. This will enable most cars to enter the internal drive aisle seamlessly, without stacking onto Laurier Avenue. Therefore, based on the considerations discussed above, the proposed throat length is considered appropriate.

Site Access #1 is approximately 72.5 metres from the Laurier Avenue West and O'Connor Street intersection, Site Access #2 is approximately 72.5 metres from the Slater Street and O'Connor Street intersection, and Site Access #3 is approximately 30.5 metres from the Laurier Avenue West and O'Connor Street intersection. The requirement of the distance between the private approach and nearest intersecting street line from Ottawa private approach bylaw is 30 metres, and all accesses meet the Ottawa private approach bylaw requirement.

10.2 Intersection Control

Based upon the projected volumes, Site Access #1 will have no control as it is an inbound only access, and Site Access #2 and Site Access #3 will have stop-control on the minor approach.

10.3 Access Intersection Design

10.3.1 Future Access Intersection Operations

The operations are noted in Section 7.4 and both 2028 and 2033 future total access intersections operate well with all movements and the overall intersection operating at LOS A or LOS B.

10.3.2 Access Intersection MMLoS

The access intersection is unsignalized, and therefore no access intersection MMLoS analysis has been conducted.

10.3.3 Recommended Design Elements

The existing sidewalk is provided along Laurier Avenue West and Slater Street, and it is recommended that the proposed accesses are constructed according to the City standard SC7.1.

11 Transportation Demand Management

11.1 Context for TDM

The mode shares used within the TIA represent the unmodified district mode shares. Overall, the modal shares are likely to be achieved, and supporting TDM measures should be provided to encourage shifts toward sustainable modes.

The development is within the downtown protected major transit station area. Total bedrooms within the development are 745 bedrooms with 449 studio/one-bedroom units, 115 two-bedroom units, and 22 three-bedroom units. No age restrictions are noted.

11.2 Need and Opportunity

The subject site has been assumed to rely predominantly on transit and walking. The reductions from the existing site result in net auto trip reduction in the study area. The study area intersections are anticipated to have the residual capacity, and as the unmodified district mode shares have been applied, risks to other network users from failing to meet mode share targets are low.

11.3 TDM Program

The “suite of post occupancy TDM measures” has been summarized in the TDM checklists. The checklist is provided in Appendix L. The key TDM measures recommended include:

- Display local area maps with walking and cycling routes, and transit route information and schedules at major entrances
- Unbundle parking from rental costs
- Provide a multimodal travel option information package to new residents

12 Transit

In Section 5.1 the trip generation by mode was estimated, including an estimate of the number of transit trips that will be generated by the proposed development. Table 26 summarizes the transit trip generation.

Table 26: Trip Generation by Transit Mode

Travel Mode	Mode Share	AM Peak Hour			PM Peak Hour		
		In	Out	Total	In	Out	Total
Transit	Varies	27	51	78	39	31	70

The proposed development is anticipated to generate an additional 78 AM and 70 PM peak hour two-way transit trips. From the trip distribution found in section 5.3, these values can be further broken down. Table 27 summarizes forecasted site-generated transit ridership trips by direction and the equivalent bus loads.

Table 27: Forecasted Site-Generated Transit Ridership

Direction	AM Peak Hour		PM Peak Hour		Service Type	Approximate Equivalent Peak Hour/Direction Bus Loads
	In	Out	In	Out		
North	1	2	2	1	Bus	Negligible
South	17	31	23	19	LRT, Bus	Half of a standard bus
East	5	10	8	6	LRT, Bus	One-fifth of a standard bus
West	4	8	6	5	LRT, Bus	Negligible

12.1 Transit Priority

Examining the study area intersection delays, negligible impacts are noted on transit movements at the study area intersections as a result of the development site traffic.

13 Network Intersection Design

13.1 Network Intersection Control

No change to the existing signalized control is recommended for the network intersections.

13.2 Network Intersection Design

13.2.1 2028 & 2033 Future Total Network Intersection Operations

The operations are noted in Section 7.4 and no capacity issues are noted.

13.2.2 Network Intersection MMLOS

Table 28 summarizes the MMLOS analysis for the network intersections within the study area. The existing and future conditions for both intersections will be the same and are considered in one row. The intersection analysis is based on the policy area of “Within 600 m of a rapid transit station” and the land-use area of “Central Area”. The MMLOS worksheets has been provided in Appendix O.

Table 28: Study Area Intersection MMLOS Analysis

Intersection	Pedestrian LOS		Bicycle LOS		Transit LOS		Truck LOS		Auto LOS	
	PLOS	Target	BLOS	Target	TLOS	Target	TrLOS	Target	ALOS	Target
Slater Street & Bank Street	C	A	F	B	D	D	-	-	A	E
Slater Street & O'Connor Street	C	A	F	A	-	-	D	D	A	E
Laurier Avenue West & Bank Street	C	A	F	A	C	D	F	D	C	E
Laurier Avenue West at O'Connor Street	D	A	A	A	-	-	F	D	A	E

The pedestrian LOS targets will not be met at the intersections within the study area. As typical for arterial roads, the crossing distance does not permit the targets to be met. To meet pedestrian LOS targets, the maximum crossing distance on all pedestrian crossings would need to be reduced to two lane-widths or less.

The bicycle LOS targets will not be met at the intersections within the study area except for the Laurier Avenue West at O'Connor Street intersection. To meet bicycle LOS targets, the left-turn configurations would need to be two-stage or include turn boxes at the intersections along O'Connor Street, Bank Street, and Slater Street.

The truck LOS targets will not be met at the intersection of Laurier Avenue West at O'Connor Street and Laurier Avenue West at Bank Street and would need at least 15-meter effective corner radius or at least two receiving lands on departure from intersection.

The City will be responsible for exploring options to address the area PLOS, BLOS, TrLOS deficiencies.

13.2.3 Recommended Design Elements

No study area intersection design elements are proposed as part of this study.

14 Summary of Improvements Indicated and Modifications Options

The following summarizes the analysis and results presented in this TIA report:

Proposed Site and Screening

- The proposed site is located inside downtown protected major transit station area, the Central and East Downtown Core Secondary Plan, and falls within the 200-meter radius of the Parliament LRT station
- The proposed site includes 586 residential units and 8,498 square feet of commercial/retail with 160 auto parking spaces and 293 bike parking spaces
- Currently a full-movement access to the site is provided via Laurier Avenue West, which also serves the above-ground parking of the BMO building at 269 Laurier Avenue West
- The shared laneway between 170 Slater Street and 269 Laurier Avenue West is proposed to be converted to one-way only, with in-only access at Laurier Avenue West, and out-only access at Slater Street
- The access to the ground-floor loading area and underground parking is proposed along Laurier Avenue West, approximately 35 meters west of O'Connor Avenue
- The anticipated full build-out and occupancy horizon is assumed to be 2028 with construction occurring in two phases
- The trip generation, location, and safety triggers were met for the TIA Screening

Existing Conditions

- Laurier Avenue West, O'Connor Street, Bank Street, and Slater Street are arterial roads in the study area
- Sidewalks are provided along both sides of the study area roads
- Protected bike lanes are provided on each side of Laurier Avenue West, and a bi-directional cycle track is provided on O'Connor Street, south of Laurier Avenue West
- Slater Street is designated as a spine route, Bank Street is designated as a local route, and both Laurier Avenue West and O'Connor Street are designated as cross-town bikeways
- The intersection of Laurier Avenue West at O'Connor Street, Bank Street at Laurier Avenue West, O'Connor Street at Slater Street, and Bank Street at Slater Street are noted to have experienced higher collisions than other locations within the study area
- No further analysis is required as part of this study

Development Generated Travel Demand

- The proposed development is forecasted to produce 281 two-way people trips during the AM peak hour and 316 two-way people trips during the PM peak hour
- Of the forecasted people trips, 46 two-way trips will be vehicle trips during the AM peak hour and 51 two-way trips will be vehicle trips during the PM peak hour
- Of the forecasted trips, 5% is anticipated to travel to the north, 60% travel to the south, 20% travel to the east, and 15% travel to the west

Background Conditions

- The background developments were explicitly included in the background conditions, along with 1.00% background growth on Bank Street and Slater Street along the mainline volumes
During both the AM and PM peak hours, intersections within the study area will be projected to operate with similar operational characteristics to future background conditions

- No capacity issues are noted at intersections within the study area, and no rationalization of background travel demand is required for this study

Development Design

- Bicycle parking is provided both external and internal to the building
- Sixteen bicycle external parking spaces and 277 internal bike parking are provided
- Two pedestrian pick-up / drop-off areas are proposed along the laneway between Laurier Avenue West and Slater Street, encouraging shared mobility travel choices such as taxi and Uber
- Pedestrian and cycling facilities are provided along the boundary street
- A 1.8-meter-wide pedestrian walkway is proposed along the laneway between Slater Street and Laurier Avenue West
- Garbage collection as well as oversized commercial and residential loading, with an HSU as the design vehicle, is anticipated to take place within the ground floor loading dock area, and two residential loading areas, with an LSU as the design vehicle, are located at P1 level
- All horizontal turning paths can be accommodated by the proposed site plan layout

Parking

- The proposed site plan includes 130 residential parking spaces, 30 visitor parking spaces, and zero retail parking spaces, which meets the maximum residential parking and minimum visitor parking requirements
- The proposed site plan includes 277 internal bicycle parking spaces and 16 external bicycle parking spaces, which meets the parking requirements

Boundary Street Design

- Laurier Avenue West and Slater Street do not meet the pedestrian MMLOS targets, and a 30 km/h, or lower, operating speed would be required to meet the targets
- Slater Street does not meet the bicycle MMLOS targets, and a 40 km/h, or lower, operating speed would be required to meet the targets
- The City may look at reducing the speed limit to help improve the PLOS and BLOS results

Access Intersections Design

- The development includes one existing full movement access to Laurier Avenue West (Site Access #1), which will be converted to an inbound only access and connects to Slater Street (Site Access #2) for egress only, and one proposed full movement access to Laurier Avenue West (Site Access #3)
- Site Access #1 and #2 are proposed to be approximately 5.0 meters wide at its most narrow section and 6.2 metres wide along the Laurier Avenue West sidewalk
- Site Access #3 width proposed to be approximately 6.0 meters at its most narrow section and 8.0 metres along Laurier Avenue West sidewalk
- The throat length for the Site Access #3 is approximately 5.7 metres measured from the edge of the sidewalk to the garage door, and the distance from edge of the sidewalk to the first conflict point is 31.5 metres. Provided the low anticipated auto trip generation at this access, as well as the urban context of the subject development, the throat length at Site Access #3 is deemed acceptable.
- Site Access #1 is located approximately 73.5 metres from the Laurier Avenue West and O'Connor Street intersection

- Site Access #2 is located approximately 72.5 metres from the Slater Street and O'Connor Street intersection
- Site Access #3 is located approximately 31 metres from the Laurier Avenue West and O'Connor Street intersection
- All accesses meet the Ottawa private approach bylaw requirement of 30 metres between the private approach and nearest intersecting street line
- Site Access #1 will have no control as it is an inbound only access, and Site Access #2 and Site Access #3 will have stop-control on the minor approach
- Existing sidewalks are provided along Laurier Avenue West and Slater Street, and the proposed accesses are recommended to be constructed to comply with the City standard SC7.1

TDM

- Supportive TDM measures to be included within the proposed development should include:
 - Display local area maps with walking and cycling routes, and transit route information and schedules at major entrances
 - Unbundle parking from rental costs
 - Provide a multimodal travel option information package to new residents

Transit

- The forecasted transit trips will include 78 two-way trips during the AM peak and 70 two-way trips during the PM peak
- Peak hour increases in transit ridership resulting from the site equate to a half of bus load southerly of the site, one-fifth of a standard bus load easterly of the site, and negligible impact northerly and westerly of the site
- Negligible impacts are noted on the transit movements at the study area intersections, and no change in transit LOS is noted throughout the study area

Network Intersection Design

- During both the AM and PM peak hours, intersection operations within the study area are projected to due to the reduction in traffic volumes projected as a result of the redevelopment of the subject site
- No capacity issues are noted at the intersections within the study
- The access intersections are projected to operate well
- No change to the existing signalized control is recommended for the network intersections
- The selected mode shares and resultant site trip generation was found to have minor impacts to the network
- No rationalization for site traffic or modal share selection is required
- The pedestrian LOS targets will not be met at intersections within the study area. To achieve the MMLOS targets, the crossing distance would need to be reduced to two lane widths or less
- The bicycle LOS targets will not be met at the existing or future intersections within the study area except for the Laurier Avenue West at O'Connor Street intersection, and the left-turn configurations would need to be two-stage or include turn boxes at the intersections along O'Connor Street, Bank Street, and Slater Street

- The truck LOS targets will not be met at the intersection of Laurier Avenue West at O'Connor Street and Laurier Avenue West at Bank Street and would need at least 15-meter effective corner radius or at least two receiving lands on departure from intersection

15 Conclusion

It is recommended that, from a transportation perspective, the proposed development applications proceed.

Prepared By:



Yu-Chu Chen, EIT
Transportation Engineering-Intern
343-777-2426
Michelle.Chen@CGHTransportation.com

Reviewed By:



Mark Crockford, P.Eng.
Senior Transportation Engineer
905-251-4070
Mark.Crockford@CGHTransportation.com

Appendix A

TIA Screening Form and PM Certification Form

City of Ottawa 2017 TIA Guidelines
Step 1 - Screening Form

Date: 4-Jul-23
Project Number: 2023-006
Project Reference: 170 Slater

1.1 Description of Proposed Development	
Municipal Address	170 Slater Street
Description of Location	Ward 14. On the south side of Slater Street, approximately 30 meters west of the intersection at Slater Street and O'Connor Street
Land Use Classification	MD [132] S33
Development Size	586 residential units and 8,498 sq. ft. of commercial/retail
Accesses	A full-movement access on Laurier Avenue West, an inbound only access on Laurier Avenue West, and a right-out only access on Slater Street
Phase of Development	Two phases
Buildout Year	2028
TIA Requirement	Full TIA Required

1.2 Trip Generation Trigger	
Land Use Type	Townhomes or apartments
Development Size	586 Units
Trip Generation Trigger	Yes

1.3 Location Triggers	
Does the development propose a new driveway to a boundary street that is designated as part of the City's Transit Priority, Rapid Transit or Spine Bicycle Networks?	Yes
Is the development in a Design Priority Area (DPA) or Transit-oriented Development (TOD) zone?	Yes
Location Trigger	Yes

1.4. Safety Triggers	
Are posted speed limits on a boundary street 80 km/hr or greater?	No
Are there any horizontal/vertical curvatures on a boundary street limits sight lines at a proposed driveway?	No
Is the proposed driveway within the area of influence of an adjacent traffic signal or roundabout (i.e. within 300 m of intersection in rural conditions, or within 150 m of intersection in urban/ suburban conditions)?	Yes
Is the proposed driveway within auxiliary lanes of an intersection?	No
Does the proposed driveway make use of an existing median break that serves an existing site?	No
Is there is a documented history of traffic operations or safety concerns on the boundary streets within 500 m of the development?	Yes
Does the development include a drive-thru facility?	No
Safety Trigger	Yes



TIA Plan Reports

On 14 June 2017, the Council of the City of Ottawa adopted new Transportation Impact Assessment (TIA) Guidelines. In adopting the guidelines, Council established a requirement for those preparing and delivering transportation impact assessments and reports to sign a letter of certification.

Individuals submitting TIA reports will be responsible for all aspects of development-related transportation assessment and reporting, and undertaking such work, in accordance and compliance with the City of Ottawa's Official Plan, the Transportation Master Plan and the Transportation Impact Assessment (2017) Guidelines.

By submitting the attached TIA report (and any associated documents) and signing this document, the individual acknowledges that s/he meets the four criteria listed below.

CERTIFICATION

1. I have reviewed and have a sound understanding of the objectives, needs and requirements of the City of Ottawa's Official Plan, Transportation Master Plan and the Transportation Impact Assessment (2017) Guidelines;
2. I have a sound knowledge of industry standard practice with respect to the preparation of transportation impact assessment reports, including multi modal level of service review;
3. I have substantial experience (more than 5 years) in undertaking and delivering transportation impact studies (analysis, reporting and geometric design) with strong background knowledge in transportation planning, engineering or traffic operations; and
4. I am either a licensed¹ or registered² professional in good standing, whose field of expertise [check appropriate field(s)] is either transportation engineering or transportation planning .

1,2 License of registration body that oversees the profession is required to have a code of conduct and ethics guidelines that will ensure appropriate conduct and representation for transportation planning and/or transportation engineering works.

City Of Ottawa
Infrastructure Services and Community
Sustainability
Planning and Growth Management
110 Laurier Avenue West, 4th fl.
Ottawa, ON K1P 1J1
Tel. : 613-580-2424
Fax: 613-560-6006

Ville d'Ottawa
Services d'infrastructure et Viabilité des
collectivités
Urbanisme et Gestion de la croissance
110, avenue Laurier Ouest
Ottawa (Ontario) K1P 1J1
Tél. : 613-580-2424
Télécopieur: 613-560-6006

Dated at Newmarket this 28 day of June, 2018.
(City)

Name: Mark Crockford
(Please Print)

Professional Title: Professional Engineer

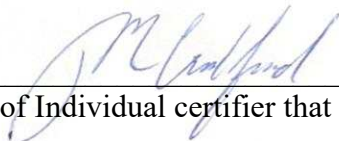
Signature of Individual certifier that s/he meets the above four criteria

Office Contact Information (Please Print)
Address: 628 Haines Road
City / Postal Code: Newmarket / L3Y 6V5
Telephone / Extension: (905) 251-4070
E-Mail Address: Mark.Crockford@CGHTransportation.com



Appendix B

Turning Movement Counts



Transportation Services - Traffic Services

Turning Movement Count - Study Results

BANK ST @ SLATER ST

Survey Date: Thursday, March 02, 2023
Start Time: 07:00

WO No: 40814
Device: Miovision

Full Study Diagram

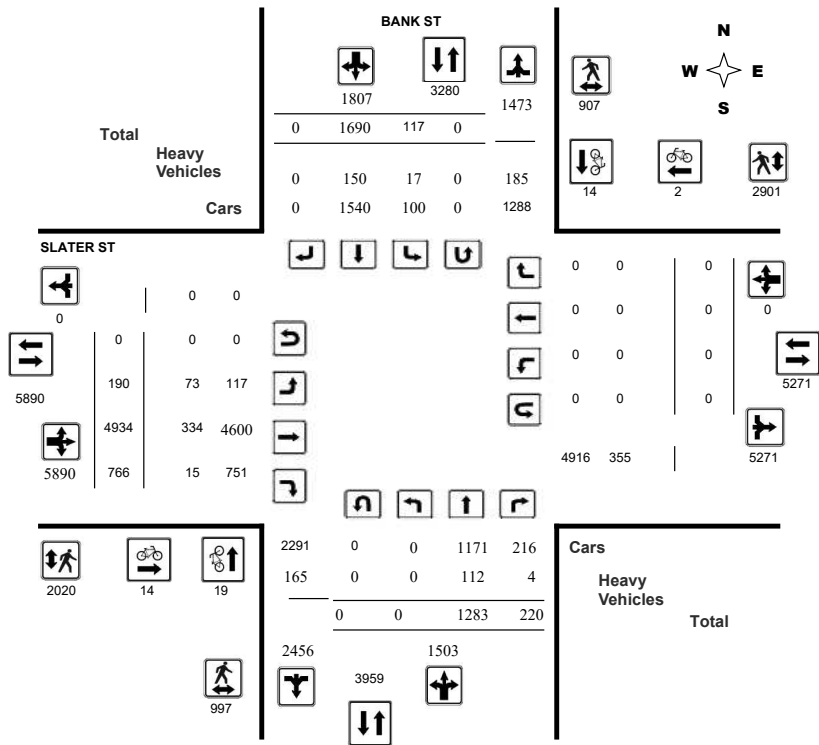

Transportation Services - Traffic Services

Turning Movement Count - Study Results

BANK ST @ SLATER ST

Survey Date: Thursday, March 02, 2023
Start Time: 07:00

WO No: 40814
Device: Miovision

Full Study Peak Hour Diagram

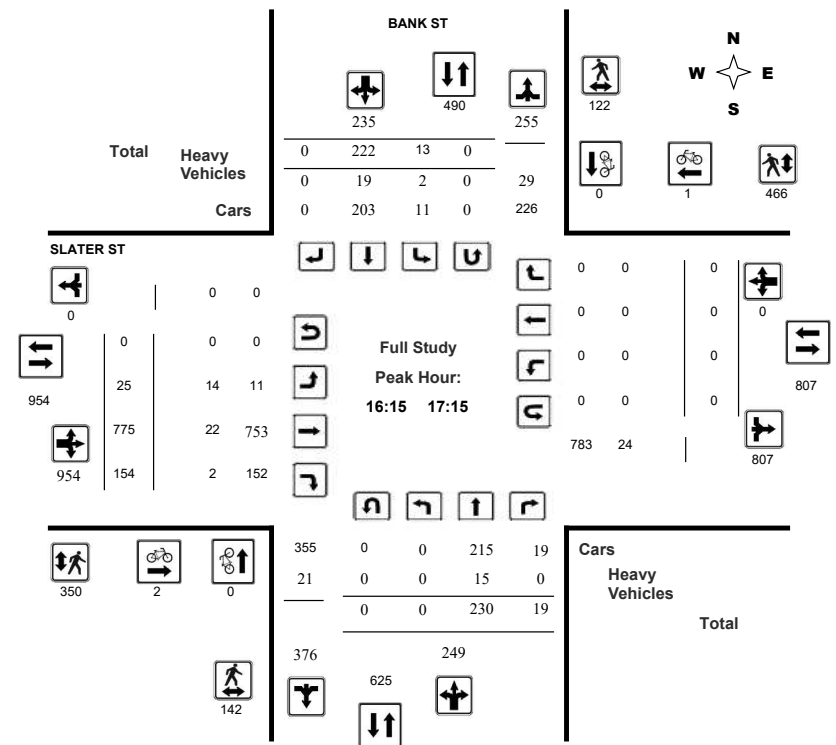



Transportation Services - Traffic Services

Turning Movement Count - Peak Hour Diagram

BANK ST @ SLATER ST

Survey Date: Thursday, March 02, 2023

Start Time: 07:00

WO No: 40814

Device: Miovision

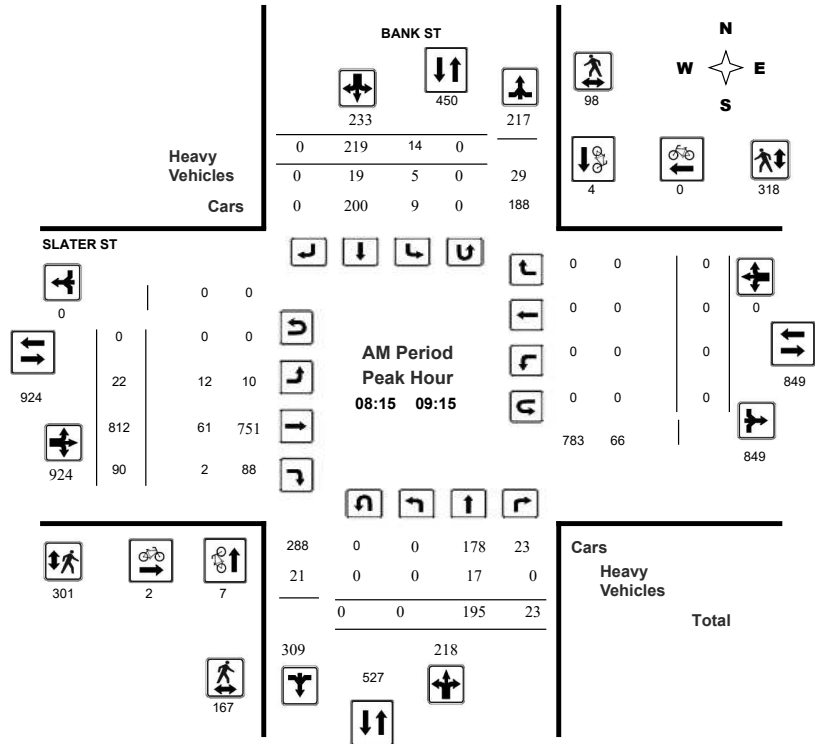

Transportation Services - Traffic Services

Turning Movement Count - Peak Hour Diagram

BANK ST @ SLATER ST

Survey Date: Thursday, March 02, 2023

Start Time: 07:00

WO No: 40814

Device: Miovision

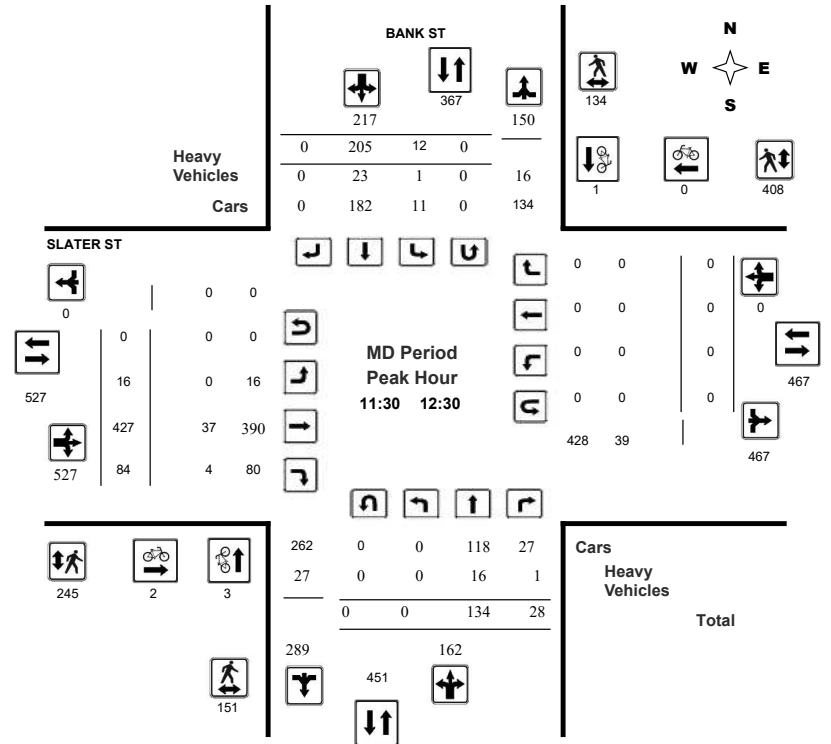



Transportation Services - Traffic Services
Turning Movement Count - Peak Hour Diagram
BANK ST @ SLATER ST

Survey Date: Thursday, March 02, 2023
 Start Time: 07:00

WO No: 40814
 Device: Miovision

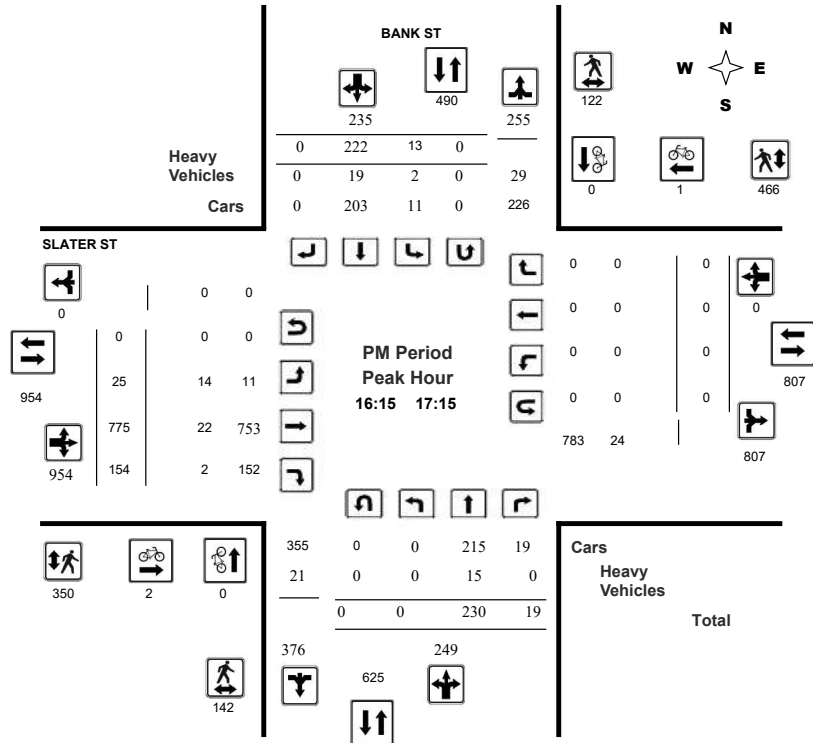

Comments



Transportation Services - Traffic Services
Turning Movement Count - Study Results
BANK ST @ SLATER ST

Survey Date: Thursday, March 02, 2023
 Start Time: 07:00

WO No: 40814
 Device: Miovision

Full Study Summary (8 HR Standard)

Survey Date: Thursday, March 02, 2023

Total Observed U-Turns
 Northbound: 0 Southbound: 0
 Eastbound: 0 Westbound: 0

AADT Factor
 1.00

Period	BANK ST					SLATER ST					WB TOT	STR TOT	Grand Total						
	Northbound			Southbound		Eastbound			Westbound										
	LT	ST	RT	NB TOT	LT	ST	RT	SB TOT	STR TOT	LT	ST	RT	EB TOT	LT	ST	RT	WB TOT	STR TOT	Grand Total
07:00 08:00	0	103	13	116	7	199	0	206	322	17	544	51	612	0	0	0	0	612	934
08:00 09:00	0	176	26	202	16	212	0	228	430	16	785	89	890	0	0	0	0	890	1320
09:00 10:00	0	161	24	185	23	223	0	246	431	39	622	78	739	0	0	0	0	739	1170
11:30 12:30	0	134	28	162	12	205	0	217	379	16	427	84	527	0	0	0	0	527	906
12:30 13:30	0	114	28	142	11	173	0	184	326	28	418	67	513	0	0	0	0	513	839
15:00 16:00	0	214	18	232	21	224	0	245	477	30	634	124	788	0	0	0	0	788	1265
16:00 17:00	0	201	20	221	15	212	0	227	448	30	776	161	967	0	0	0	0	967	1415
17:00 18:00	0	180	63	243	12	242	0	254	497	14	728	112	854	0	0	0	0	854	1351
Sub Total	0	1283	220	1503	117	1690	0	1807	3310	190	4934	766	5890	0	0	0	0	5890	9200
U Turns	0																		
Total	0	1283	220	1503	117	1690	0	1807	3310	190	4934	766	5890	0	0	0	0	5890	9200
EQ 12Hr	0	1783	306	2089	163	2349	0	2512	4601	264	6858	1065	8187	0	0	0	0	8187	12788
Note: These values are calculated by multiplying the totals by the appropriate expansion factor.														1.39					
AVG 12Hr	0	1783	306	2089	163	3077	0	2512	4601	264	6858	1065	8187	0	0	0	0	8187	12788
Note: These volumes are calculated by multiplying the Equivalent 12 hr. totals by the AADT factor.														1.00					
AVG 24Hr	0	2336	401	2737	214	4031	0	3291	6027	346	8984	1395	10725	0	0	0	0	10725	16752
Note: These volumes are calculated by multiplying the Average Daily 12 hr. totals by 12 to 24 expansion factor.														1.31					
Note: U-Turns provided for approach totals. Refer to 'U-Turn' Report for specific breakdown.																			



Transportation Services - Traffic Services

Turning Movement Count - Study Results

BANK ST @ SLATER ST

Survey Date: Thursday, March 02, 2023

WO No: 40814

Start Time: 07:00

Device: Miovision

Full Study 15 Minute Increments

Table with columns for Time Period, Northbound, Southbound, Eastbound, Westbound, and Grand Total. Rows show 15-minute intervals from 07:00 to 17:45.

Note: U-Turns are included in Totals.



Transportation Services - Traffic Services

Turning Movement Count - Study Results

BANK ST @ SLATER ST

Survey Date: Thursday, March 02, 2023

WO No: 40814

Start Time: 07:00

Device: Miovision

Full Study Cyclist Volume

Table with columns for Time Period, Northbound, Southbound, Street Total, Eastbound, Westbound, Street Total, and Grand Total. Rows show 15-minute intervals from 07:00 to 17:45.



Transportation Services - Traffic Services

Turning Movement Count - Study Results

BANK ST @ SLATER ST

Survey Date: Thursday, March 02, 2023

WO No: 40814

Start Time: 07:00

Device: Miovision

Full Study Pedestrian Volume

Time Period	BANK ST		Total	SLATER ST		Total	Grand Total
	NB Approach (E or W Crossing)	SB Approach (E or W Crossing)		EB Approach (N or S Crossing)	WB Approach (N or S Crossing)		
07:00 07:15	24	14	38	31	25	56	94
07:15 07:30	37	17	54	38	38	76	130
07:30 07:45	24	11	35	33	50	83	118
07:45 08:00	32	24	56	49	71	120	176
08:00 08:15	27	33	60	58	59	117	177
08:15 08:30	27	32	59	64	74	138	197
08:30 08:45	70	22	92	72	114	186	278
08:45 09:00	38	18	56	91	81	172	228
09:00 09:15	32	26	58	74	49	123	181
09:15 09:30	21	25	46	57	75	132	178
09:30 09:45	14	19	33	40	40	80	113
09:45 10:00	17	20	37	32	60	92	129
11:30 11:45	24	16	40	37	64	101	141
11:45 12:00	28	32	60	42	82	124	184
12:00 12:15	61	37	98	85	120	205	303
12:15 12:30	38	49	87	81	142	223	310
12:30 12:45	33	22	55	74	119	193	248
12:45 13:00	27	49	76	68	121	189	265
13:00 13:15	34	32	66	49	104	153	219
13:15 13:30	20	27	47	50	89	139	186
15:00 15:15	22	39	61	56	103	159	220
15:15 15:30	28	26	54	60	83	143	197
15:30 15:45	21	22	43	76	86	162	205
15:45 16:00	26	28	54	74	112	186	240
16:00 16:15	39	36	75	84	149	233	308
16:15 16:30	36	32	68	82	122	204	272
16:30 16:45	23	28	51	82	119	201	252
16:45 17:00	42	29	71	81	117	198	269
17:00 17:15	41	33	74	105	108	213	287
17:15 17:30	40	42	82	72	132	204	286
17:30 17:45	31	36	67	69	104	173	240
17:45 18:00	20	31	51	54	89	143	194
Total	997	907	1904	2020	2901	4921	6825



Transportation Services - Traffic Services

Turning Movement Count - Study Results

BANK ST @ SLATER ST

Survey Date: Thursday, March 02, 2023

WO No: 40814

Start Time: 07:00

Device: Miovision

Full Study Heavy Vehicles

Time Period	BANK ST					SLATER ST					Grand Total								
	Northbound		Southbound			Eastbound			Westbound										
	LT	ST	RT	N TOT	LT	ST	RT	S TOT	STR TOT	LT		ST	RT	E TOT	LT	ST	RT	W TOT	STR TOT
07:00 07:15	0	3	1	8	0	4	0	10	18	3	15	0	18	0	0	0	16	34	26
07:15 07:30	0	3	0	6	1	2	0	8	14	2	10	1	13	0	0	0	11	24	19
07:30 07:45	0	3	0	5	2	2	0	12	17	5	12	0	17	0	0	0	14	31	24
07:45 08:00	0	4	0	10	0	5	0	13	23	4	9	1	14	0	0	0	9	23	23
08:00 08:15	0	5	0	8	1	3	0	12	20	3	18	0	21	0	0	0	19	40	30
08:15 08:30	0	3	0	6	1	3	0	9	15	2	10	0	12	0	0	0	11	23	19
08:30 08:45	0	5	0	9	2	4	0	15	24	4	20	0	24	0	0	0	22	46	35
08:45 09:00	0	5	0	12	1	7	0	15	27	2	13	0	15	0	0	0	14	29	28
09:00 09:15	0	4	0	11	1	5	0	14	25	4	18	2	24	0	0	0	19	43	34
09:15 09:30	0	5	0	10	0	4	0	11	21	2	17	1	20	0	0	0	17	37	29
09:30 09:45	0	3	0	8	0	5	0	9	17	1	23	0	24	0	0	0	23	47	32
09:45 10:00	0	4	0	10	2	6	0	12	22	0	9	0	9	0	0	0	11	20	21
11:30 11:45	0	3	0	10	0	4	0	7	17	0	10	3	13	0	0	0	10	23	20
11:45 12:00	0	4	1	13	1	7	0	12	25	0	7	1	8	0	0	0	9	17	21
12:00 12:15	0	5	0	12	0	7	0	12	24	0	15	0	15	0	0	0	15	30	27
12:15 12:30	0	4	0	9	0	5	0	9	18	0	5	0	5	0	0	0	5	10	14
12:30 12:45	0	6	0	14	0	6	0	12	26	0	12	2	14	0	0	0	12	26	26
12:45 13:00	0	6	0	10	0	4	0	10	20	0	13	0	13	0	0	0	13	26	23
13:00 13:15	0	2	0	9	0	7	0	9	18	0	9	0	9	0	0	0	9	18	18
13:15 13:30	0	5	0	9	0	4	0	9	18	0	12	0	12	0	0	0	12	24	21
15:00 15:15	0	1	1	9	1	7	0	11	20	2	9	0	11	0	0	0	11	22	21
15:15 15:30	0	2	0	5	0	3	0	11	16	6	6	0	12	0	0	0	6	18	17
15:30 15:45	0	4	0	11	0	6	0	13	24	3	10	1	14	0	0	0	10	24	24
15:45 16:00	0	0	0	5	0	4	0	7	12	3	8	1	12	0	0	0	8	20	16
16:00 16:15	0	2	1	6	1	3	0	9	15	3	7	0	10	0	0	0	9	19	17
16:15 16:30	0	6	0	12	1	5	0	17	29	5	8	1	14	0	0	0	9	23	26
16:30 16:45	0	3	0	8	0	5	0	11	19	3	6	0	9	0	0	0	6	15	17
16:45 17:00	0	2	0	5	0	3	0	9	14	4	4	0	8	0	0	0	4	12	13
17:00 17:15	0	4	0	11	1	6	0	13	24	2	4	1	7	0	0	0	5	12	18
17:15 17:30	0	1	0	6	0	5	0	12	18	6	3	0	9	0	0	0	3	12	15
17:30 17:45	0	4	0	7	0	3	0	10	17	3	4	0	7	0	0	0	4	11	14
17:45 18:00	0	1	0	7	1	6	0	9	16	1	8	0	9	0	0	0	9	18	17
Total: None	0	112	4	281	17	150	0	352	633	73	334	15	422	0	0	0	355	777	705



Transportation Services - Traffic Services

Turning Movement Count - Study Results

BANK ST @ SLATER ST

Survey Date: Thursday, March 02, 2023

WO No: 40814

Start Time: 07:00

Device: Miovision

Full Study 15 Minute U-Turn Total

Time Period	BANK ST		SLATER ST		Total
	Northbound U-Turn Total	Southbound U-Turn Total	Eastbound U-Turn Total	Westbound U-Turn Total	
07:00 - 07:15	0	0	0	0	0
07:15 - 07:30	0	0	0	0	0
07:30 - 07:45	0	0	0	0	0
07:45 - 08:00	0	0	0	0	0
08:00 - 08:15	0	0	0	0	0
08:15 - 08:30	0	0	0	0	0
08:30 - 08:45	0	0	0	0	0
08:45 - 09:00	0	0	0	0	0
09:00 - 09:15	0	0	0	0	0
09:15 - 09:30	0	0	0	0	0
09:30 - 09:45	0	0	0	0	0
09:45 - 10:00	0	0	0	0	0
11:30 - 11:45	0	0	0	0	0
11:45 - 12:00	0	0	0	0	0
12:00 - 12:15	0	0	0	0	0
12:15 - 12:30	0	0	0	0	0
12:30 - 12:45	0	0	0	0	0
12:45 - 13:00	0	0	0	0	0
13:00 - 13:15	0	0	0	0	0
13:15 - 13:30	0	0	0	0	0
15:00 - 15:15	0	0	0	0	0
15:15 - 15:30	0	0	0	0	0
15:30 - 15:45	0	0	0	0	0
15:45 - 16:00	0	0	0	0	0
16:00 - 16:15	0	0	0	0	0
16:15 - 16:30	0	0	0	0	0
16:30 - 16:45	0	0	0	0	0
16:45 - 17:00	0	0	0	0	0
17:00 - 17:15	0	0	0	0	0
17:15 - 17:30	0	0	0	0	0
17:30 - 17:45	0	0	0	0	0
17:45 - 18:00	0	0	0	0	0
Total	0	0	0	0	0



Turning Movement Count

Summary Report

Including AM and PM Peak Hours

All Vehicles Except Bicycles



Bank Street & Laurier Avenue Ottawa, ON

Survey Date: Wednesday, April 12, 2023

Start Time: 0700 AADT Factor: 0.9

Weather AM: Cloudy 9° C

Survey Duration: 4 Hrs.

Survey Hours: 0700-0900 & 1600-1800

Weather PM: Mostly Sunny 17° C

Surveyor(s): T. Carmody

Time Period	Laurier Ave.				Laurier Ave.				Bank St.				Bank St.				Street Total	Grand Total					
	Eastbound		Westbound		Northbound		Southbound																
	LT	ST	RT	UT	LT	ST	RT	UT	LT	ST	RT	UT	LT	ST	RT	UT							
0700-0800	0	324	46	0	370	1	183	24	0	208	578	0	119	71	0	190	20	174	42	0	236	426	1004
0800-0900	2	299	51	0	352	0	235	39	0	274	626	1	174	135	0	310	12	241	58	0	311	621	1247
1600-1700	0	228	80	0	308	2	281	79	0	362	670	1	187	77	0	265	18	285	76	0	379	644	1314
1700-1800	1	215	64	0	280	2	241	47	0	290	570	2	173	69	0	244	9	222	47	0	278	522	1092
Totals	3	1066	241	0	1310	5	940	189	0	1134	2444	4	653	352	0	1009	59	922	223	0	1204	2213	4657

Equivalent 12 & 24-hour Vehicle Volumes Including the Annual Average Daily Traffic (AADT) Factor
Applicable to the Day and Month of the Turning Movement Count

Expansion factors are applied exclusively to standard weekday 8-hour turning movement counts conducted during the hours of 0700h - 1000h, 1130h - 1330h and 1500h - 1800h

Equivalent 12-hour vehicle volumes. These volumes are calculated by multiplying the 8-hour totals by the 8 → 12 expansion factor of 1.39																						
Equ. 12 Hr	n/a	n/a	n/a	n/a	n/a	n/a	n/a	n/a	n/a	n/a	n/a	n/a	n/a	n/a	n/a	n/a	n/a	n/a	n/a	n/a	n/a	n/a
Average daily 12-hour vehicle volumes. These volumes are calculated by multiplying the equivalent 12-hour totals by the AADT factor of 0.9																						
AADT 12-hr	n/a	n/a	n/a	n/a	n/a	n/a	n/a	n/a	n/a	n/a	n/a	n/a	n/a	n/a	n/a	n/a	n/a	n/a	n/a	n/a	n/a	n/a
24-Hour AADT. These volumes are calculated by multiplying the average daily 12-hour vehicle volumes by the 12 → 24 expansion factor of 1.31																						
AADT 24 Hr	n/a	n/a	n/a	n/a	n/a	n/a	n/a	n/a	n/a	n/a	n/a	n/a	n/a	n/a	n/a	n/a	n/a	n/a	n/a	n/a	n/a	n/a

AADT and expansion factors provided by the City of Ottawa

AM Peak Hour Factor → 0.95											Highest Hourly Vehicle Volume Between 0700h & 0900h												
AM Peak Hr	LT	ST	RT	UT	Total	LT	ST	RT	UT	Total	Str. Tot.	LT	ST	RT	UT	Total	LT	ST	RT	UT	Total	Str. Tot.	Gr. Tot.
0800-0900	2	299	51	0	352	0	235	39	0	274	626	1	174	135	0	310	12	241	58	0	311	621	1247

PM Peak Hour Factor → 0.93											Highest Hourly Vehicle Volume Between 1600h & 1800h												
PM Peak Hr	LT	ST	RT	UT	Total	LT	ST	RT	UT	Total	Str. Tot.	LT	ST	RT	UT	Total	LT	ST	RT	UT	Total	Str. Tot.	Gr. Tot.
1600-1700	0	228	80	0	308	2	281	79	0	362	670	1	187	77	0	265	18	285	76	0	379	644	1314

Comments:

Transit buses comprise 59.54% of the heavy vehicle traffic. Traffic was quite congested between 1600 & 1635h. The bicycle totals include 28 electric personal E-transportation types. The pedestrian crossing totals include 7 with accessibility issues using either a cane, walker or wheelchair.

Notes:

1. Includes all vehicle types except bicycles, electric bicycles, and electric scooters.
2. When expansion and AADT factors are applied, the results will differ slightly due to rounding.



Turning Movement Count Summary, AM and PM Peak Hour Flow Diagrams All Vehicles Except Bicycles

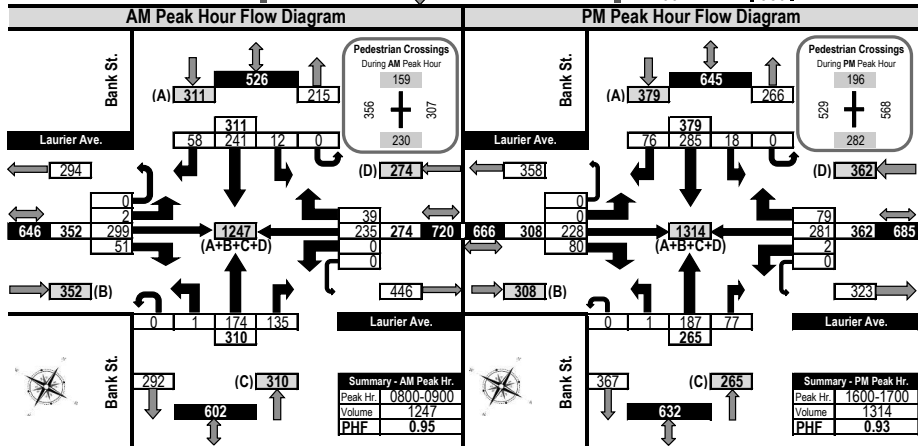
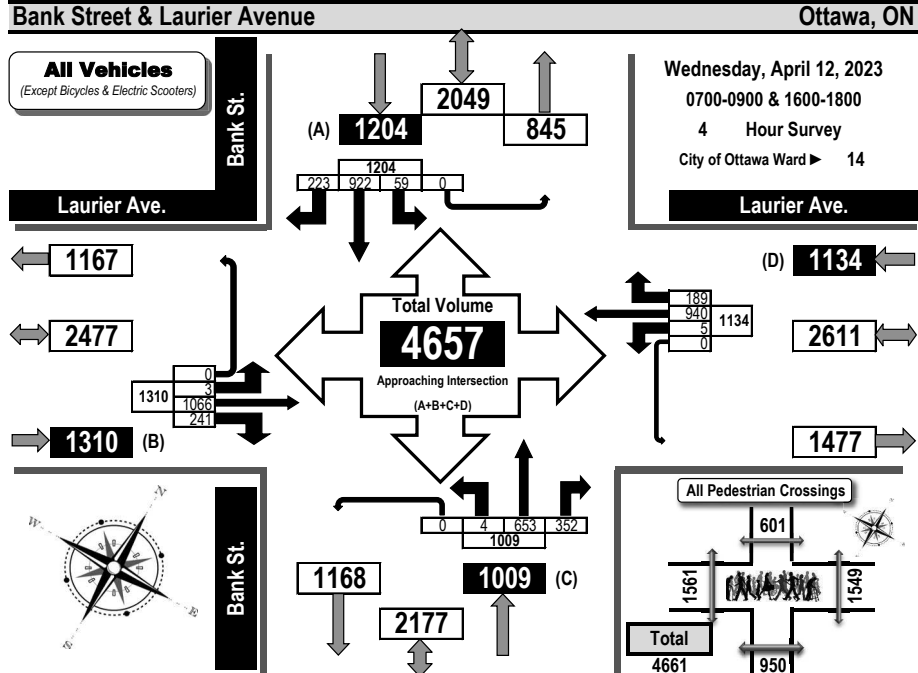

Printed on: 4/21/2023

Prepared by: thetrafficsspecialist@gmail.com

Flow Diagrams: AM PM Peak



Turning Movement Count Heavy Vehicle Summary (FHWA Class 4-13) Flow Diagram

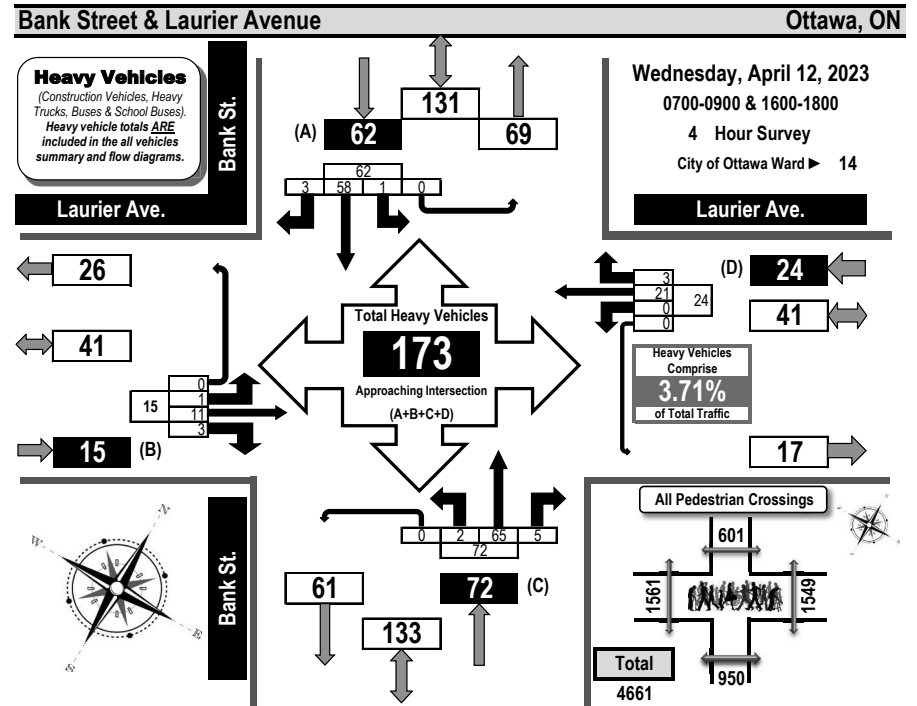

Time Period	Laurier Ave. Eastbound				Laurier Ave. Westbound				Bank St. Northbound				Bank St. Southbound				SB Tot	GR Tot			
	LT	ST	RT	UT	EB Tot	LT	ST	RT	UT	WB Tot	LT	ST	RT	UT	NB Tot	LT			ST	RT	UT
0700-0800	0	3	2	0	5	0	2	0	0	2	0	13	1	0	14	0	11	1	0	12	33
0800-0900	1	5	0	0	6	0	16	2	0	18	0	27	3	0	30	0	19	1	0	20	74
1600-1700	0	2	0	0	2	0	0	0	0	0	2	13	1	0	16	0	12	1	0	13	31
1700-1800	0	1	1	0	2	0	3	1	0	4	0	12	0	0	12	1	16	0	0	17	35
Totals	1	11	3	0	15	0	21	3	0	24	2	65	5	0	72	1	58	3	0	62	173

Comments:

Transit buses comprise 59.54% of the heavy vehicle traffic. Traffic was quite congested between 1600 & 1635h. The bicycle totals include 28 electric personal E-transportation types. The pedestrian crossing totals include 7 with accessibility issues using either a cane, walker or wheelchair.

Printed on: 4/21/2023

Prepared by: thetrafficsspecialist@gmail.com

Summary: Heavy Vehicles



Turning Movement Count All Buses Summary (FHWA Class 4 ONLY) Flow Diagram

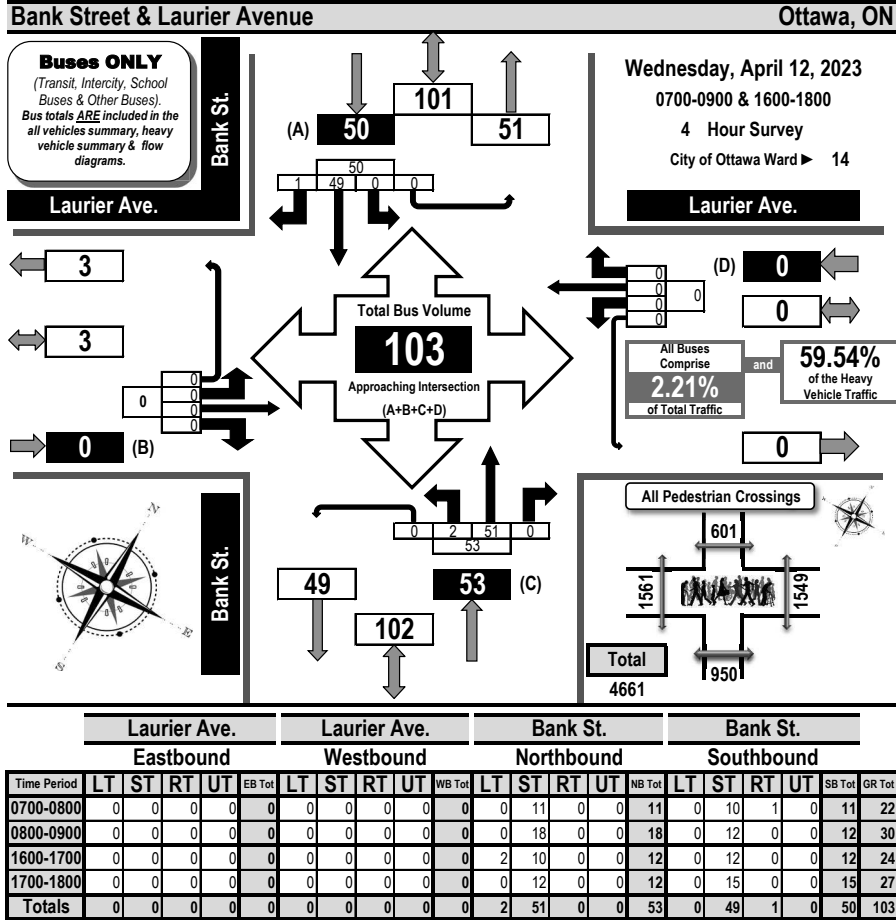

Comments:
Transit buses comprise 59.54% of the heavy vehicle traffic. Traffic was quite congested between 1600 & 1635h. The bicycle totals include 28 electric personal E-transportation types. The pedestrian crossing totals include 7 with accessibility issues using either a cane, walker or wheelchair.



Turning Movement Count Bicycle Summary Flow Diagram

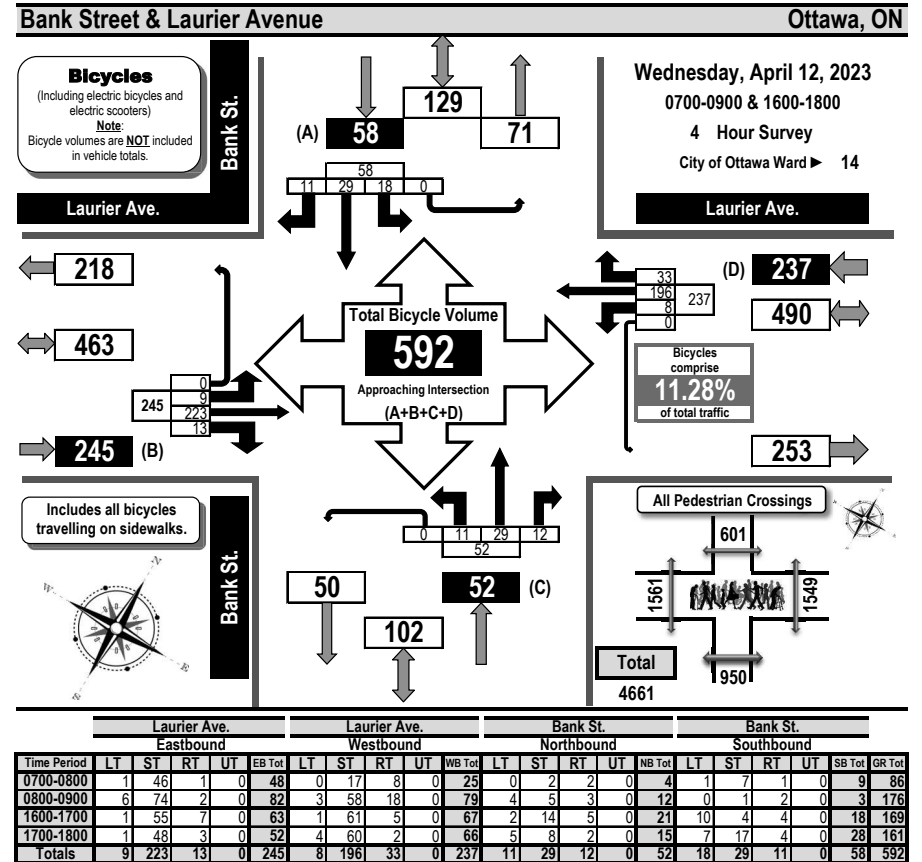

Comments:
Transit buses comprise 59.54% of the heavy vehicle traffic. Traffic was quite congested between 1600 & 1635h. The bicycle totals include 28 electric personal E-transportation types. The pedestrian crossing totals include 7 with accessibility issues using either a cane, walker or wheelchair.



Turning Movement Count Pedestrian Crossings Summary and Flow Diagram



Bank Street & Laurier Avenue Ottawa, ON

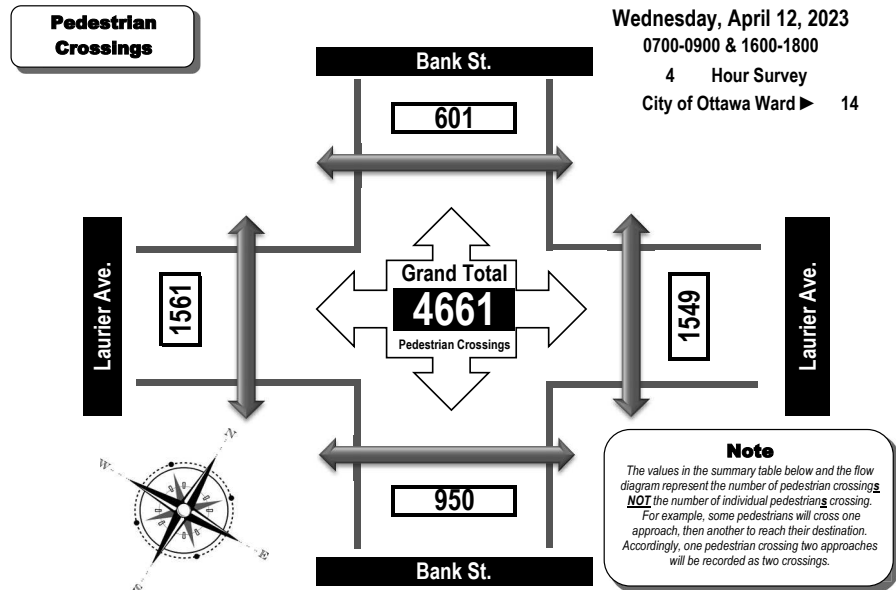

Time Period	West Side Crossing Laurier Ave.	East Side Crossing Laurier Ave.	Street Total	South Side Crossing Bank St.	North Side Crossing Bank St.	Street Total	Grand Total
0700-0800	202	196	398	163	72	235	633
0800-0900	356	307	663	230	159	389	1052
1600-1700	529	568	1097	282	196	478	1575
1700-1800	474	478	952	275	174	449	1401
Totals	1561	1549	3110	950	601	1551	4661

Comments:
Transit buses comprise 59.54% of the heavy vehicle traffic. Traffic was quite congested between 1600 & 1635h. The bicycle totals include 28 electric personal E-transportation types. The pedestrian crossing totals include 7 with accessibility issues using either a cane, walker or wheelchair.



Turning Movement Count Summary Report Including AM and PM Peak Hours All Vehicles Except Bicycles



O'Connor Street & Slater Street Ottawa, ON

Survey Date: Wednesday, April 12, 2023 Start Time: 0700 AADT Factor: 0.9
Weather AM: Cloudy 9° C Survey Duration: 4 Hrs. Survey Hours: 0700-0900 & 1600-1800
Weather PM: Mostly Sunny 17° C Surveyor(s): T. Carmody

Time Period	Slater St. Eastbound					Slater St. Westbound					O'Connor St. Northbound					O'Connor St. Southbound							
	LT	ST	RT	UT	E/B Tot	LT	ST	RT	UT	W/B Tot	LT	ST	RT	UT	N/B Tot	LT	ST	RT	UT	S/B Tot			
	Street Total					Street Total					Street Total					Street Total							
0700-0800	0	455	36	0	491	0	0	0	0	0	0	0	0	0	0	0	96	192	0	0	288	288	779
0800-0900	0	637	55	0	692	0	0	0	0	0	0	692	0	0	0	0	119	235	0	0	354	354	1046
1600-1700	0	747	60	0	807	0	0	0	0	0	0	807	0	0	0	0	112	350	0	0	462	462	1269
1700-1800	0	630	74	0	704	0	0	0	0	0	0	704	0	0	0	0	77	308	0	0	385	385	1089
Totals	0	2469	225	0	2694	0	0	0	0	0	0	2694	0	0	0	0	404	1085	0	0	1489	1489	4183

Equivalent 12 & 24-hour Vehicle Volumes Including the Annual Average Daily Traffic (AADT) Factor Applicable to the Day and Month of the Turning Movement Count

Expansion factors are applied exclusively to standard weekday 8-hour turning movement counts conducted during the hours of 0700h - 1000h, 1130h - 1330h and 1500h - 1800h

Equivalent 12-hour vehicle volumes. These volumes are calculated by multiplying the 8-hour totals by the 8 → 12 expansion factor of 1.39																								
Equ. 12 Hr	n/a	n/a	n/a	n/a	n/a	n/a	n/a	n/a	n/a	n/a	n/a	n/a	n/a	n/a	n/a	n/a	n/a	n/a	n/a	n/a	n/a	n/a	n/a	n/a
Average daily 12-hour vehicle volumes. These volumes are calculated by multiplying the equivalent 12-hour totals by the AADT factor of: 0.9																								
AADT 12-hr	n/a	n/a	n/a	n/a	n/a	n/a	n/a	n/a	n/a	n/a	n/a	n/a	n/a	n/a	n/a	n/a	n/a	n/a	n/a	n/a	n/a	n/a	n/a	n/a
24-Hour AADT. These volumes are calculated by multiplying the average daily 12-hour vehicle volumes by the 12 → 24 expansion factor of 1.31																								
AADT 24 Hr	n/a	n/a	n/a	n/a	n/a	n/a	n/a	n/a	n/a	n/a	n/a	n/a	n/a	n/a	n/a	n/a	n/a	n/a	n/a	n/a	n/a	n/a	n/a	n/a

AADT and expansion factors provided by the City of Ottawa

AM Peak Hour Factor → 0.94												Highest Hourly Vehicle Volume Between 0700h & 0900h											
AM Peak Hr	LT	ST	RT	UT	Total	LT	ST	RT	UT	Total	Str. Tot.	LT	ST	RT	UT	Total	LT	ST	RT	UT	Total	Str. Tot.	Gr. Tot.
0800-0900	0	637	55	0	692	0	0	0	0	0	692	0	0	0	0	0	119	235	0	0	354	354	1046

PM Peak Hour Factor → 0.95												Highest Hourly Vehicle Volume Between 1600h & 1800h											
PM Peak Hr	LT	ST	RT	UT	Total	LT	ST	RT	UT	Total	Str. Tot.	LT	ST	RT	UT	Total	LT	ST	RT	UT	Total	Str. Tot.	Gr. Tot.
1615-1715	0	747	61	0	808	0	0	0	0	0	808	0	0	0	0	0	105	356	0	0	461	461	1269

Comments:
OC Transpo and Para Transpo buses and private buses comprise 58.62% of the heavy vehicle traffic. The bicycle totals include 8 personal E-transportation types. The pedestrian crossing totals include 2 with accessibility issues using either a cane, walker or wheelchair.

- Notes:**
- Includes all vehicle types except bicycles, electric bicycles, and electric scooters.
 - When expansion and AADT factors are applied, the results will differ slightly due to rounding.



Turning Movement Count Summary, AM and PM Peak Hour Flow Diagrams All Vehicles Except Bicycles

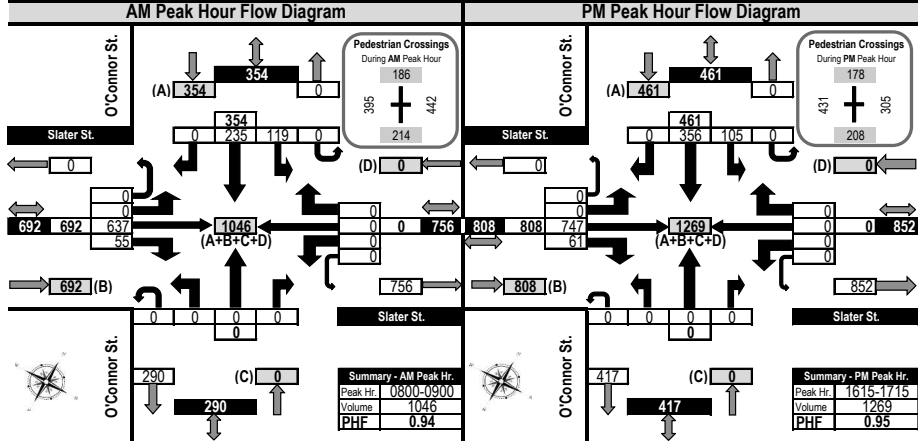
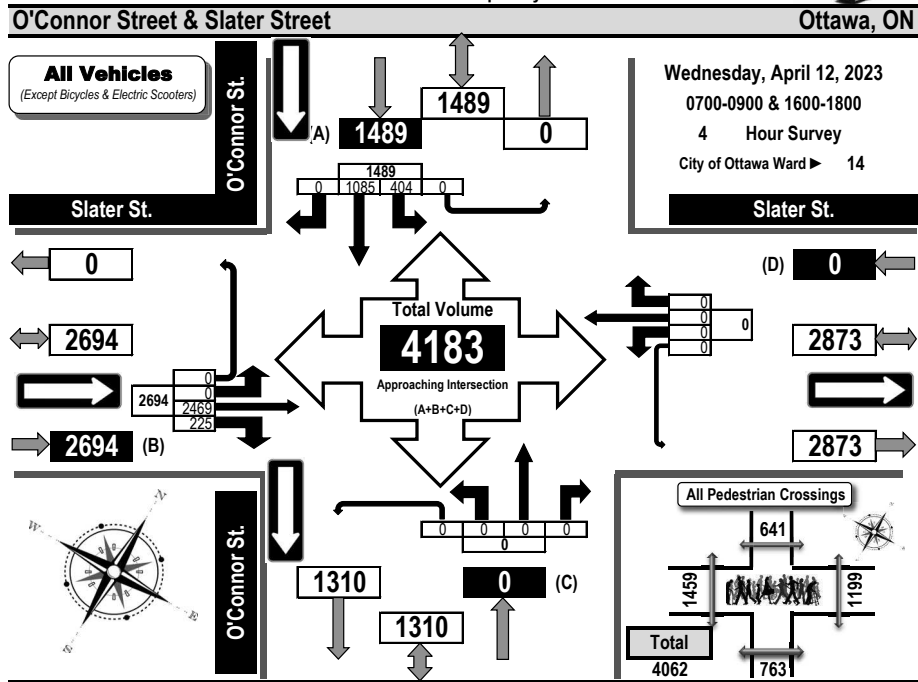

Turning Movement Count Heavy Vehicle Summary (FHWA Class 4-13) Flow Diagram

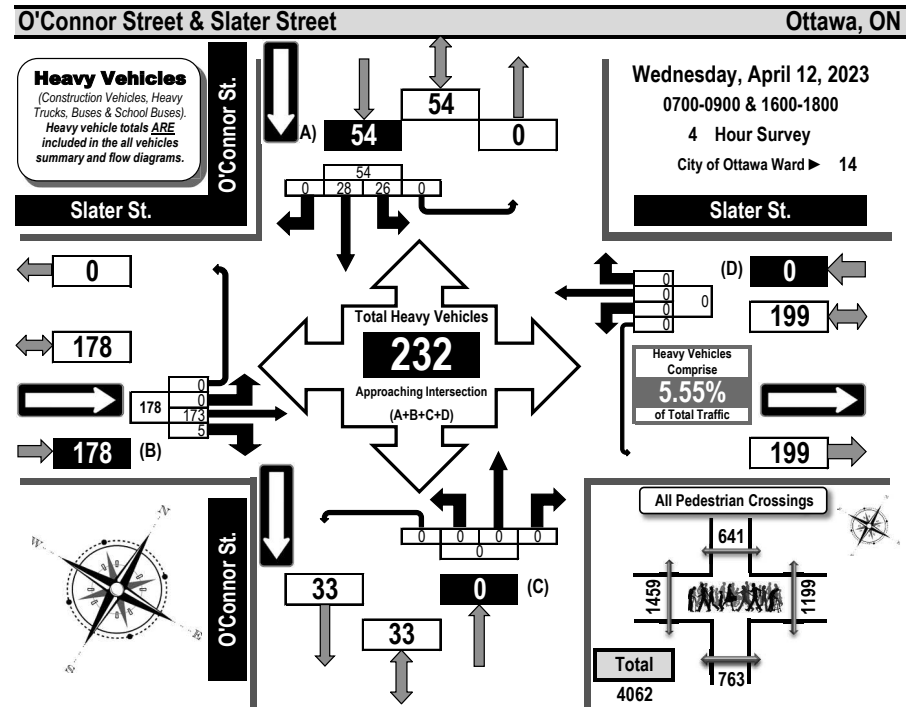

Time Period	Slater St. Eastbound				Slater St. Westbound				O'Connor St. Northbound				O'Connor St. Southbound				SB Tot	GR Tot			
	LT	ST	RT	UT	EB Tot	LT	ST	RT	UT	WB Tot	LT	ST	RT	UT	NB Tot	LT			ST	RT	UT
0700-0800	0	55	0	0	55	0	0	0	0	0	0	0	0	0	0	11	9	0	0	20	75
0800-0900	0	63	3	0	66	0	0	0	0	0	0	0	0	0	0	5	11	0	0	16	82
1600-1700	0	37	2	0	39	0	0	0	0	0	0	0	0	0	0	6	5	0	0	11	50
1700-1800	0	18	0	0	18	0	0	0	0	0	0	0	0	0	0	4	3	0	0	7	25
Totals	0	173	5	0	178	0	0	0	0	0	0	0	0	0	0	26	28	0	0	54	232

Comments:

OC Transpo and Para Transpo buses and private buses comprise 58.62% of the heavy vehicle traffic. The bicycle totals include 8 personal E-transportation types. The pedestrian crossing totals include 2 with accessibility issues using either a cane, walker or wheelchair.



Turning Movement Count All Buses Summary (FHWA Class 4 ONLY) Flow Diagram

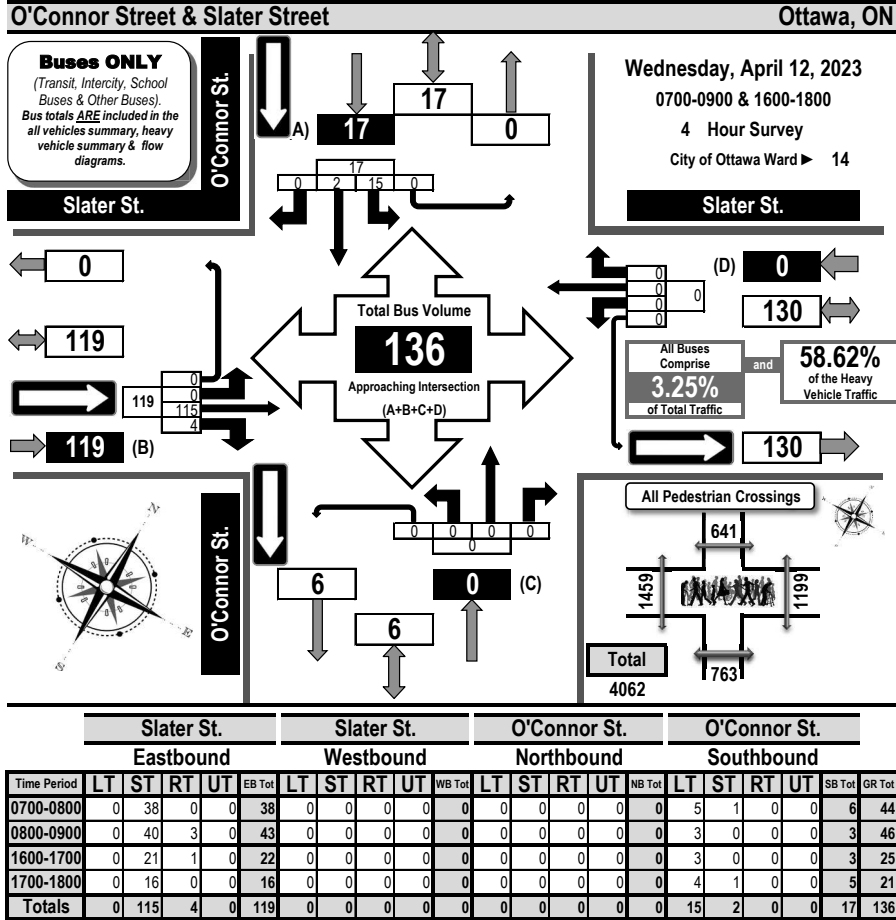

Comments:
OC Transpo and Para Transpo buses and private buses comprise 58.62% of the heavy vehicle traffic. The bicycle totals include 8 personal E-transportation types. The pedestrian crossing totals include 2 with accessibility issues using either a cane, walker or wheelchair.



Turning Movement Count Bicycle Summary Flow Diagram

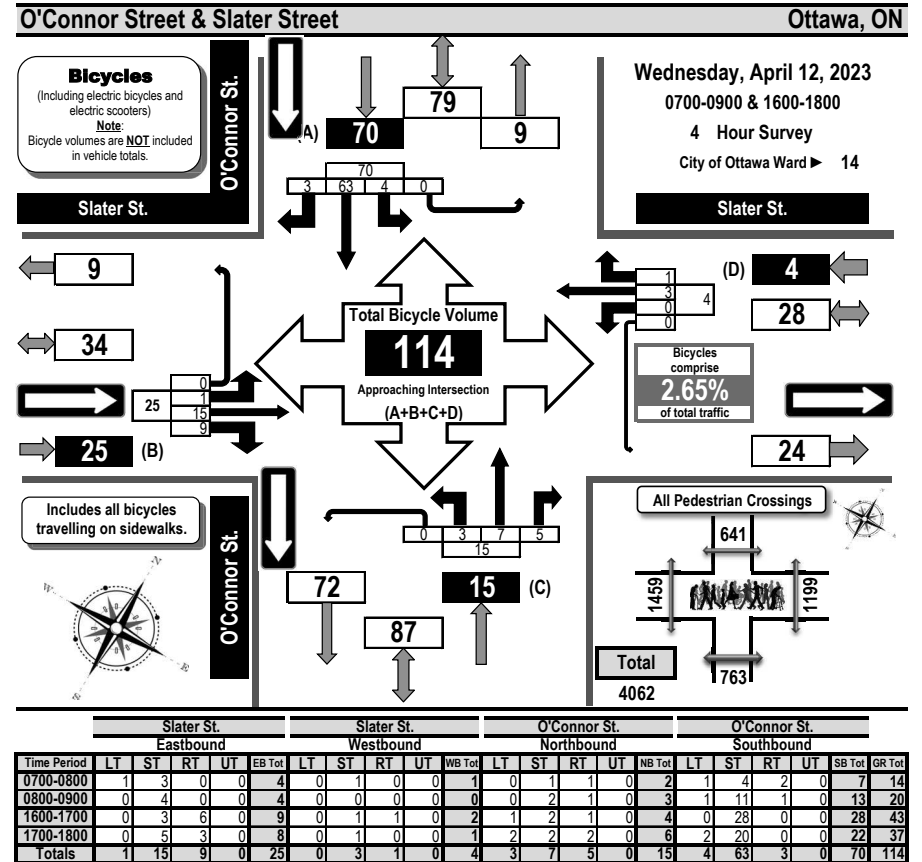

Comments:
OC Transpo and Para Transpo buses and private buses comprise 58.62% of the heavy vehicle traffic. The bicycle totals include 8 personal E-transportation types. The pedestrian crossing totals include 2 with accessibility issues using either a cane, walker or wheelchair.



Turning Movement Count Pedestrian Crossings Summary and Flow Diagram



O'Connor Street & Slater Street Ottawa, ON

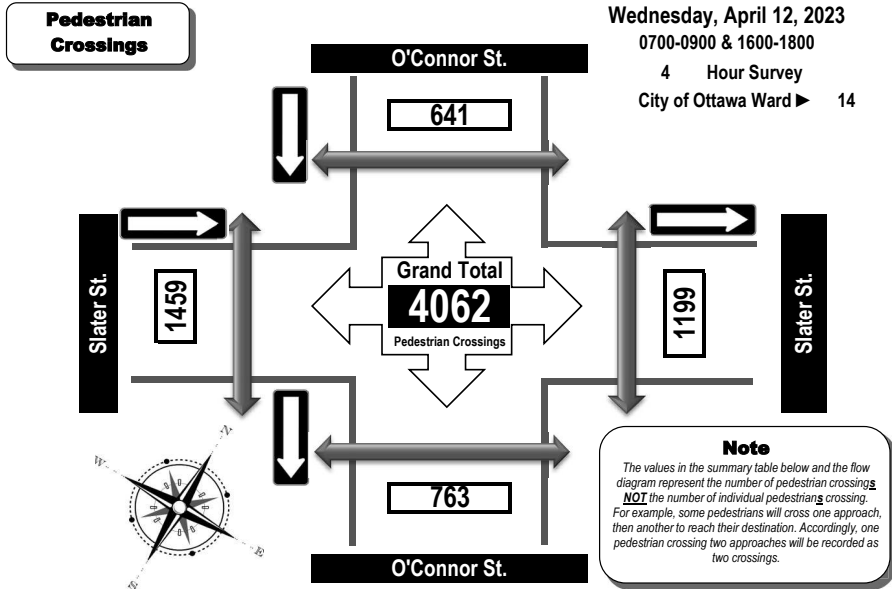

Time Period	West Side Crossing Slater St.	East Side Crossing Slater St.	Street Total	South Side Crossing O'Connor St.	North Side Crossing O'Connor St.	Street Total	Grand Total
0700-0800	295	200	495	146	118	264	759
0800-0900	395	442	837	214	186	400	1237
1600-1700	443	284	727	231	160	391	1118
1700-1800	326	273	599	172	177	349	948
Totals	1459	1199	2658	763	641	1404	4062

Comments:
OC Transpo and Para Transpo buses and private buses comprise 58.62% of the heavy vehicle traffic. The bicycle totals include 8 personal E-transportation types. The pedestrian crossing totals include 2 with accessibility issues using either a cane, walker or wheelchair.



Turning Movement Count Summary Report Including AM and PM Peak Hours All Vehicles Except Bicycles



Laurier Avenue & O'Connor Street Ottawa, ON

Survey Date: Wednesday, April 12, 2023 Start Time: 0700 AADT Factor: 0.9
Weather AM: Cloudy 9° C Survey Duration: 4 Hrs. Survey Hours: 0700-0900 & 1600-1800
Weather PM: Mostly Sunny 17° C Surveyor(s): T. Carmody

Time Period	Laurier Ave. Eastbound					Laurier Ave. Westbound					O'Connor St. Northbound					O'Connor St. Southbound								
	LT	ST	RT	UT	E/B Tot	LT	ST	RT	UT	W/B Tot	Street Total	LT	ST	RT	UT	N/B Tot	Street Total	LT	ST	RT	UT	S/B Tot	Street Total	Grand Total
	0700-0800	0	185	163	0	348	132	233	0	0	365	713	0	0	0	0	0	31	182	24	0	237	237	950
0800-0900	0	189	146	0	335	138	301	0	0	439	774	0	0	0	0	0	27	231	32	0	290	290	1064	
1600-1700	0	253	104	0	357	194	279	0	0	473	830	0	0	0	0	0	55	344	31	0	430	430	1260	
1700-1800	0	220	99	0	319	202	230	0	0	432	751	0	0	0	0	0	27	324	28	0	379	379	1130	
Totals	0	847	512	0	1359	666	1043	0	0	1709	3068	0	0	0	0	0	140	1081	115	0	1336	1336	4404	

Equivalent 12 & 24-hour Vehicle Volumes Including the Annual Average Daily Traffic (AADT) Factor Applicable to the Day and Month of the Turning Movement Count

Expansion factors are applied exclusively to standard weekday 8-hour turning movement counts conducted during the hours of 0700h - 1000h, 1130h - 1330h and 1500h - 1800h

Equivalent 12-hour vehicle volumes. These volumes are calculated by multiplying the 8-hour totals by the 8 → 12 expansion factor of 1.39																									
Equ. 12 Hr	n/a	n/a	n/a	n/a	n/a	n/a	n/a	n/a	n/a	n/a	n/a	n/a	n/a	n/a	n/a	n/a	n/a	n/a	n/a	n/a	n/a	n/a	n/a	n/a	n/a
Average daily 12-hour vehicle volumes. These volumes are calculated by multiplying the equivalent 12-hour totals by the AADT factor of: 0.9																									
AADT 12-hr	n/a	n/a	n/a	n/a	n/a	n/a	n/a	n/a	n/a	n/a	n/a	n/a	n/a	n/a	n/a	n/a	n/a	n/a	n/a	n/a	n/a	n/a	n/a	n/a	n/a
24-hour AADT. These volumes are calculated by multiplying the average daily 12-hour vehicle volumes by the 12 → 24 expansion factor of 1.31																									
AADT 24 Hr	n/a	n/a	n/a	n/a	n/a	n/a	n/a	n/a	n/a	n/a	n/a	n/a	n/a	n/a	n/a	n/a	n/a	n/a	n/a	n/a	n/a	n/a	n/a	n/a	n/a

AADT and expansion factors provided by the City of Ottawa

AM Peak Hour Factor → 0.96													Highest Hourly Vehicle Volume Between 0700h & 0900h												
AM Peak Hr	LT	ST	RT	UT	Total	LT	ST	RT	UT	Total	Str. Tot.	LT	ST	RT	UT	Total	LT	ST	RT	UT	Total	Str. Tot.	Gr. Tot.		
0745-0845	0	205	149	0	354	143	296	0	0	439	793	0	0	0	0	0	28	224	26	0	278	278	1071		
PM Peak Hour Factor → 0.95													Highest Hourly Vehicle Volume Between 1600h & 1800h												
PM Peak Hr	LT	ST	RT	UT	Total	LT	ST	RT	UT	Total	Str. Tot.	LT	ST	RT	UT	Total	LT	ST	RT	UT	Total	Str. Tot.	Gr. Tot.		
1600-1700	0	253	104	0	357	194	279	0	0	473	830	0	0	0	0	0	55	344	31	0	430	430	1260		

Comments:

OC Transpo and Para Transpo buses and school buses comprise 8.97% of the heavy vehicle traffic. Westbound traffic backed up from Bank Street during the PM peak period. The bicycle totals include 28 personal E-transportation types. The pedestrian crossing totals include 7 with accessibility issues using either a cane, walker or wheelchair.

Notes:

1. Includes all vehicle types except bicycles, electric bicycles, and electric scooters.
2. When expansion and AADT factors are applied, the results will differ slightly due to rounding.



Turning Movement Count Summary, AM and PM Peak Hour Flow Diagrams All Vehicles Except Bicycles

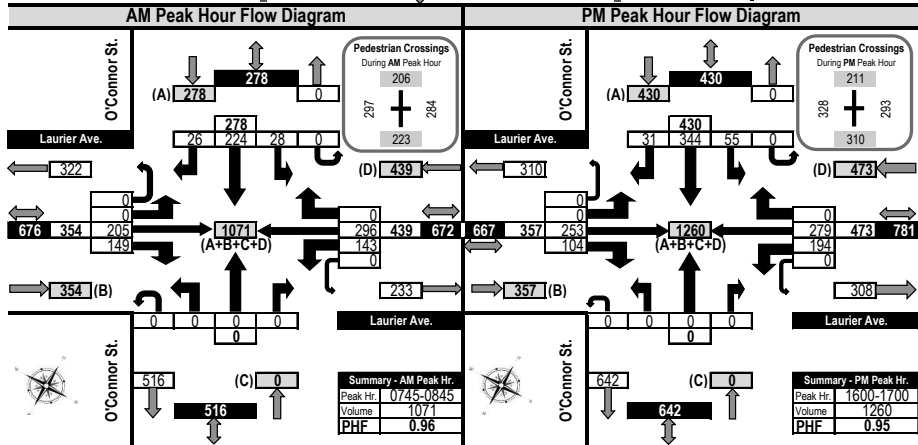
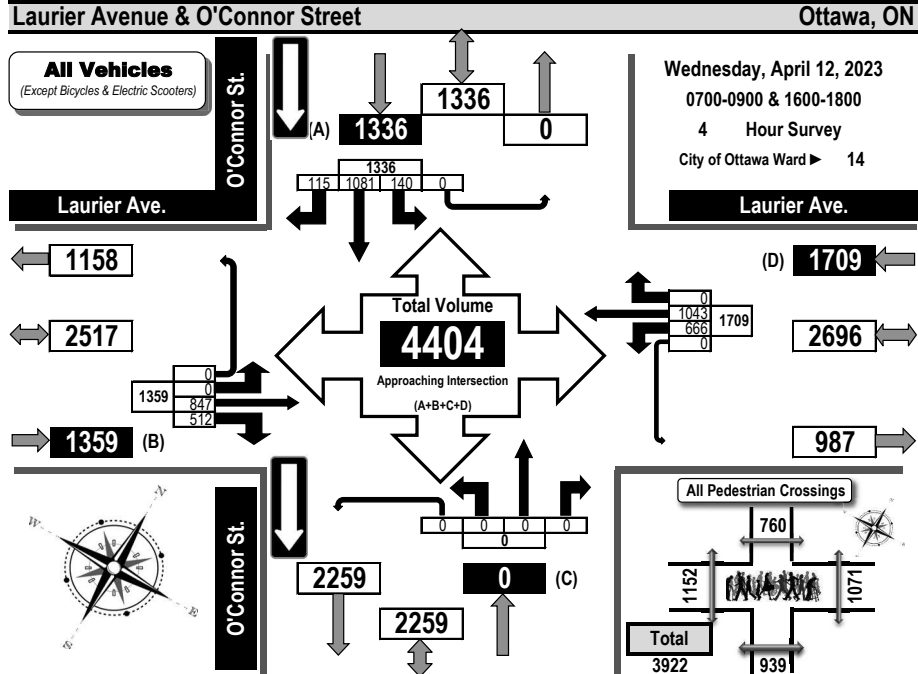

Printed on: 4/21/2023

Prepared by: thetrafficsspecialist@gmail.com

Flow Diagrams: AM PM Peak



Turning Movement Count Heavy Vehicle Summary (FHWA Class 4-13) Flow Diagram

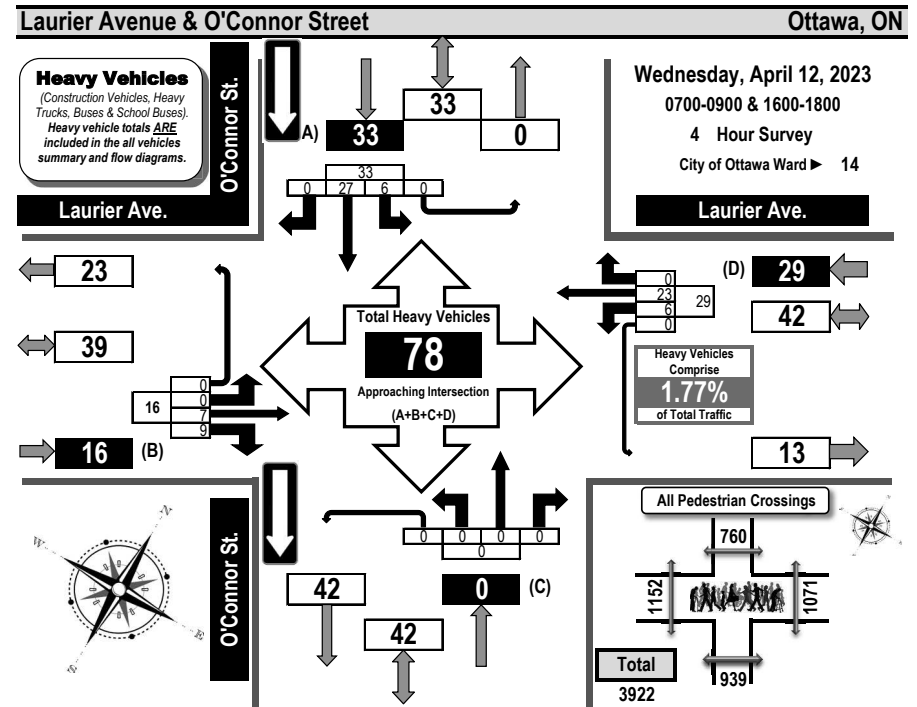

Time Period	Laurier Ave. Eastbound				Laurier Ave. Westbound				O'Connor St. Northbound				O'Connor St. Southbound				SB Tot	GR Tot			
	LT	ST	RT	UT	EB Tot	LT	ST	RT	UT	WB Tot	LT	ST	RT	UT	NB Tot	LT			ST	RT	UT
0700-0800	0	2	2	0	4	1	2	0	0	3	0	0	0	0	0	3	6	0	0	9	16
0800-0900	0	3	4	0	7	3	17	0	0	20	0	0	0	0	0	2	12	0	0	14	41
1600-1700	0	1	2	0	3	2	0	0	0	2	0	0	0	0	0	1	6	0	0	7	12
1700-1800	0	1	1	0	2	0	4	0	0	4	0	0	0	0	0	0	3	0	0	3	9
Totals	0	7	9	0	16	6	23	0	0	29	0	0	0	0	0	6	27	0	0	33	78

Comments:

OC Transpo and Para Transpo buses and school buses comprise 8.97% of the heavy vehicle traffic. Westbound traffic backed up from Bank Street during the PM peak period. The bicycle totals include 28 personal E-transportation types. The pedestrian crossing totals include 7 with accessibility issues using either a cane, walker or wheelchair.

Printed on: 4/21/2023

Prepared by: thetrafficsspecialist@gmail.com

Summary: Heavy Vehicles



Turning Movement Count All Buses Summary (FHWA Class 4 ONLY) Flow Diagram



Laurier Avenue & O'Connor Street Ottawa, ON

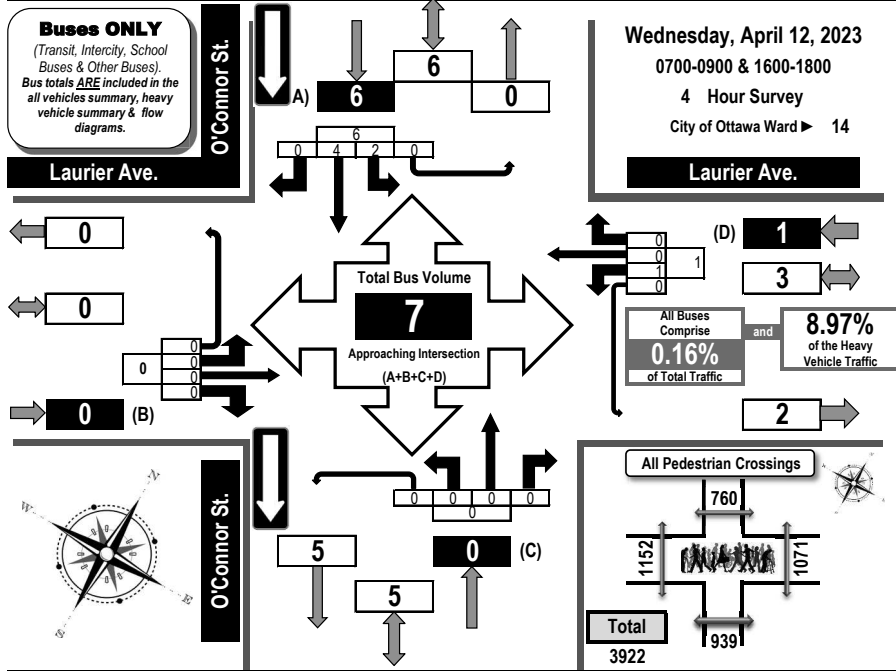

Time Period	Laurier Ave. Eastbound				Laurier Ave. Westbound				O'Connor St. Northbound				O'Connor St. Southbound				SB Tot	GR Tot
	LT	ST	RT	UT	LT	ST	RT	UT	LT	ST	RT	UT	LT	ST	RT	UT		
0700-0800	0	0	0	0	0	0	0	0	0	0	0	0	0	1	0	0	1	1
0800-0900	0	0	0	0	0	0	0	0	0	0	0	0	0	0	3	0	3	3
1600-1700	0	0	0	0	0	1	0	0	0	1	0	0	0	1	0	0	1	2
1700-1800	0	0	0	0	0	0	0	0	0	0	0	0	0	0	1	0	1	1
Totals	0	0	0	0	0	1	0	0	0	1	0	0	0	2	4	0	6	7

Comments:
OC Transpo and Para Transpo buses and school buses comprise 8.97% of the heavy vehicle traffic. Westbound traffic backed up from Bank Street during the PM peak period. The bicycle totals include 28 personal E-transportation types. The pedestrian crossing totals include 7 with accessibility issues using either a cane, walker or wheelchair.



Turning Movement Count Bicycle Summary Flow Diagram



Laurier Avenue & O'Connor Street Ottawa, ON

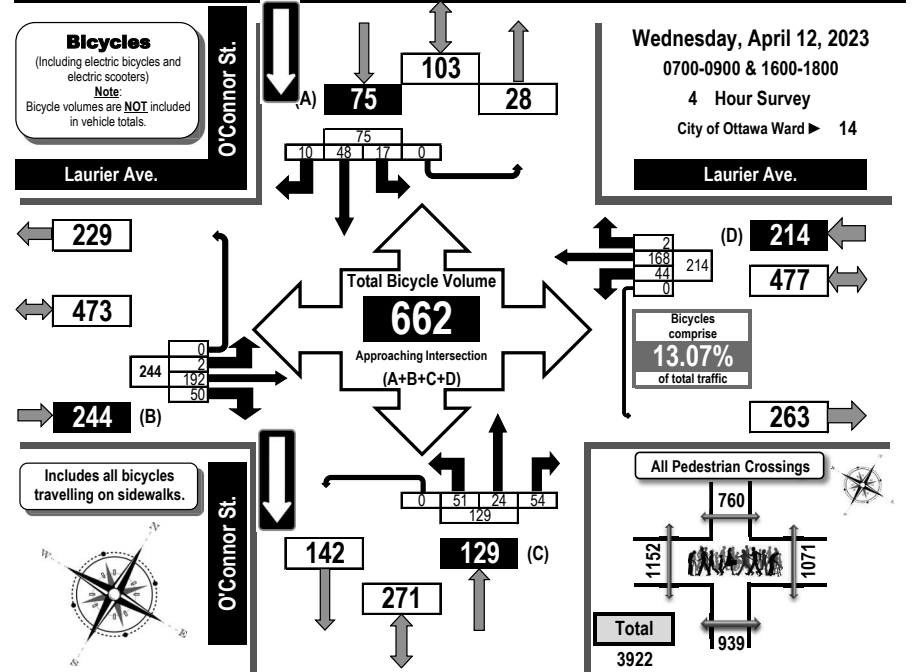

Time Period	Laurier Ave. Eastbound				Laurier Ave. Westbound				O'Connor St. Northbound				O'Connor St. Southbound				SB Tot	GR Tot	
	LT	ST	RT	UT	LT	ST	RT	UT	LT	ST	RT	UT	LT	ST	RT	UT			
0700-0800	1	41	5	0	47	6	20	0	26	8	5	6	19	1	0	1	0	2	94
0800-0900	0	61	11	0	72	6	53	1	60	26	5	23	54	3	5	1	0	9	195
1600-1700	1	51	14	0	66	16	44	1	61	9	6	10	25	11	23	4	0	38	190
1700-1800	0	39	20	0	59	16	51	0	67	8	8	15	31	2	20	4	0	26	183
Totals	2	192	50	0	244	44	168	2	214	51	24	54	129	17	48	10	0	75	662

Comments:
OC Transpo and Para Transpo buses and school buses comprise 8.97% of the heavy vehicle traffic. Westbound traffic backed up from Bank Street during the PM peak period. The bicycle totals include 28 personal E-transportation types. The pedestrian crossing totals include 7 with accessibility issues using either a cane, walker or wheelchair.



Turning Movement Count Pedestrian Crossings Summary and Flow Diagram



Diagrams, Maps and Photographs



Laurier Avenue & O'Connor Street Ottawa, ON

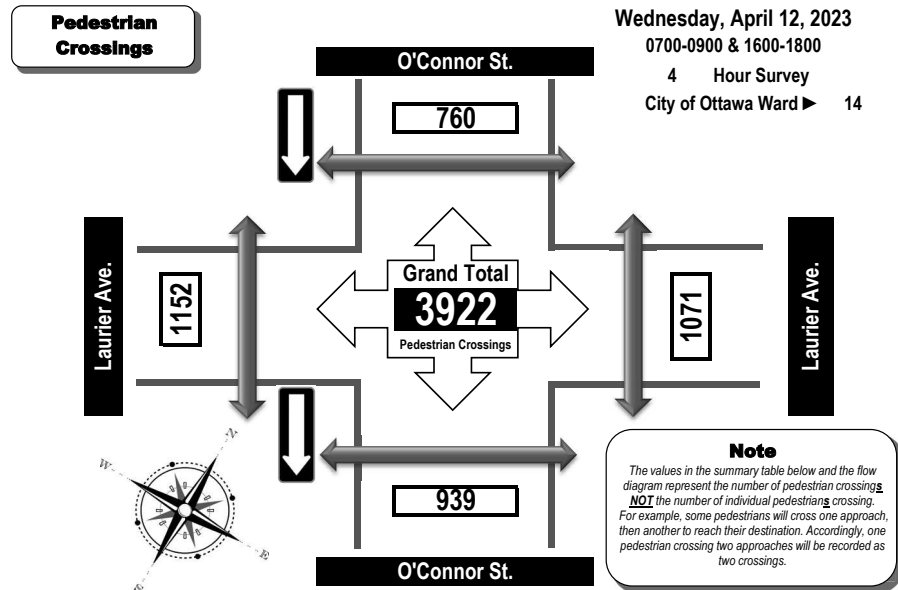

Time Period	West Side Crossing Laurier Ave.	East Side Crossing Laurier Ave.	Street Total	South Side Crossing O'Connor St.	North Side Crossing O'Connor St.	Street Total	Grand Total
0700-0800	234	156	390	149	127	276	666
0800-0900	296	330	626	240	213	453	1079
1600-1700	328	293	621	310	211	521	1142
1700-1800	294	292	586	240	209	449	1035
Totals	1152	1071	2223	939	760	1699	3922

Comments:

OC Transpo and Para Transpo buses and school buses comprise 8.97% of the heavy vehicle traffic. Westbound traffic backed up from Bank Street during the PM peak period. The bicycle totals include 28 personal E-transportation types. The pedestrian crossing totals include 7 with accessibility issues using either a cane, walker or wheelchair.





Turning Movement Count Summary, AM and PM Peak Hour Flow Diagrams All Vehicles Except Bicycles



Laurier Avenue & 170 Slater Street Access Ottawa, ON

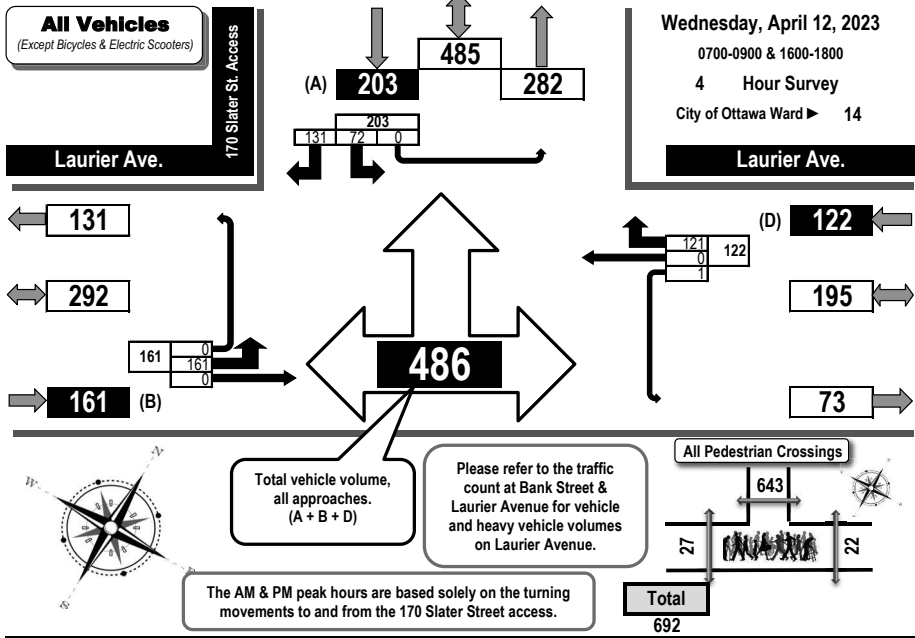

Turning Movement Count Pedestrian Crossings Summary and Flow Diagram



Laurier Avenue & 170 Slater Street Access Ottawa, ON

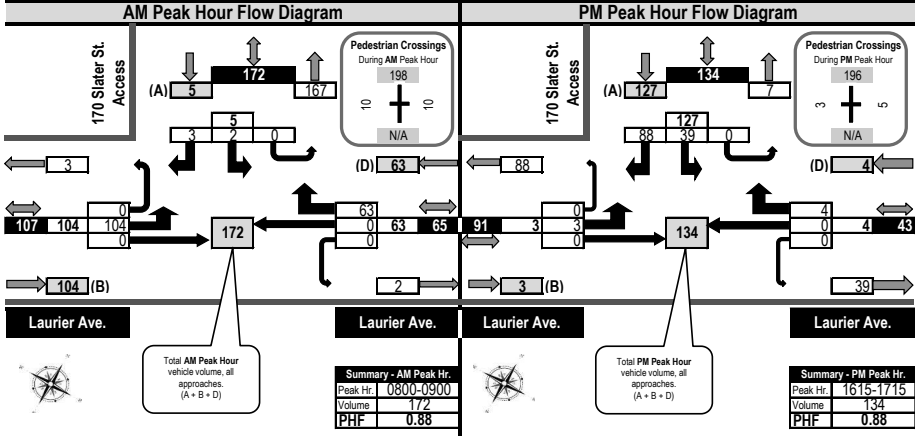
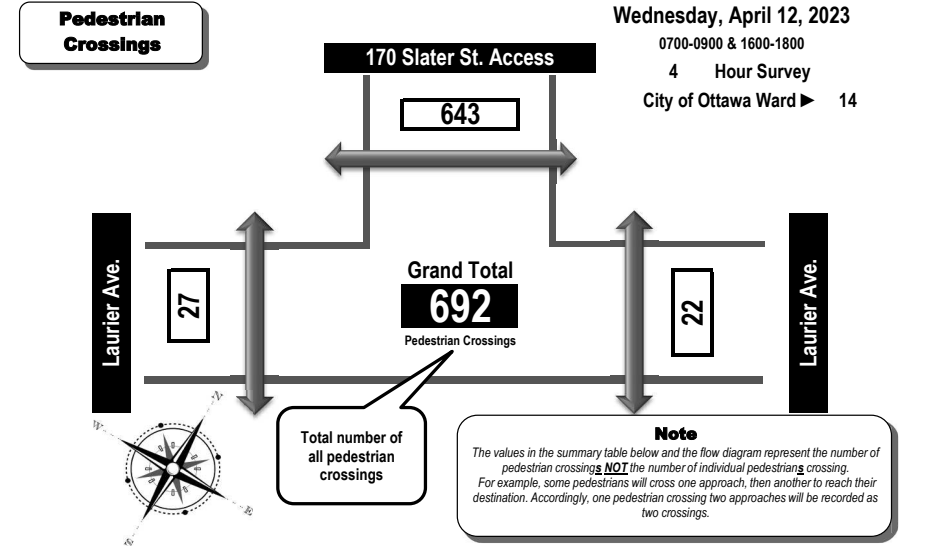

Time Period	West Side Crossing Laurier Ave.	East Side Crossing Laurier Ave.	Street Total	South Side Crossing N/A	North Side Crossing 170 Slater St. Access	Street Total	Grand Total
0700-0800	8	3	11		89	89	100
0800-0900	10	10	20		198	198	218
1600-1700	3	4	7		181	181	188
1700-1800	6	5	11		175	175	186
Totals	27	22	49		643	643	692

Comments:
Please refer to the traffic count at Bank Street and Laurier Avenue for through vehicle and heavy vehicle volumes on Laurier Avenue. Eastbound traffic backs up (AM peak period) from O'Connor Street and when this occurs, some eastbound left-turning motorists travel in the westbound lane to complete their turn. Westbound traffic backs up from Bank Street during the PM peak period.



Turning Movement Count

Summary Report

Including AM and PM Peak Hours

All Vehicles Except Bicycles



Laurier Avenue & 170 Slater Street Access Ottawa, ON

Survey Date: Wednesday, April 12, 2023 **Start Time:** 0700 **AADT Factor:** 0.9
Weather AM: Cloudy 9° C **Survey Duration:** 4 Hrs. **Survey Hours:** 0700-0900 & 1600-1800
Weather PM: Mostly Sunny 17° C **Surveyor(s):** T. Carmody

Time Period	Laurier Ave.				Laurier Ave.				N/A				170 Slater St. Access				Street Total	Grand Total					
	Eastbound		Westbound		Northbound		Southbound		Eastbound		Westbound		Northbound		Southbound								
	LT	ST	RT	UT	LT	ST	RT	UT	LT	ST	RT	UT	LT	ST	RT	UT							
0700-0800	50	0	0	0	50	0	0	48	1	49	99	0	0	0	0	0	5	0	2	0	7	7	106
0800-0900	104	0	0	0	104	0	0	63	0	63	167	0	0	0	0	0	2	0	3	0	5	5	172
1600-1700	4	0	0	0	4	0	0	4	0	4	8	0	0	0	0	0	30	0	73	0	103	103	111
1700-1800	3	0	0	0	3	0	0	6	0	6	9	0	0	0	0	0	35	0	53	0	88	88	97
Totals	161	0	0	0	161	0	0	121	1	122	283	0	0	0	0	0	72	0	131	0	203	203	486

Equivalent 12 & 24-hour Vehicle Volumes Including the Annual Average Daily Traffic (AADT) Factor
Applicable to the Day and Month of the Turning Movement Count

Expansion factors are applied exclusively to standard weekday 8-hour turning movement counts conducted during the hours of 0700h - 1000h, 1130h - 1330h and 1500h - 1800h

Equivalent 12-hour vehicle volumes. These volumes are calculated by multiplying the 8-hour totals by the 8 ➔ 12 expansion factor of 1.39																							
Equ. 12 Hr	n/a	n/a	n/a	n/a	n/a	n/a	n/a	n/a	n/a	n/a	n/a	n/a	n/a	n/a	n/a	n/a	n/a	n/a	n/a	n/a	n/a	n/a	n/a
Average daily 12-hour vehicle volumes. These volumes are calculated by multiplying the equivalent 12-hour totals by the AADT factor of: 0.9																							
AADT 12-hr	n/a	n/a	n/a	n/a	n/a	n/a	n/a	n/a	n/a	n/a	n/a	n/a	n/a	n/a	n/a	n/a	n/a	n/a	n/a	n/a	n/a	n/a	n/a
24-Hour AADT. These volumes are calculated by multiplying the average daily 12-hour vehicle volumes by the 12 ➔ 24 expansion factor of 1.31																							
AADT 24 Hr	n/a	n/a	n/a	n/a	n/a	n/a	n/a	n/a	n/a	n/a	n/a	n/a	n/a	n/a	n/a	n/a	n/a	n/a	n/a	n/a	n/a	n/a	n/a

AADT and expansion factors provided by the City of Ottawa

AM Peak Hour Factor ➔ 0.88						Highest Hourly Vehicle Volume Between 0700h & 0900h																		
AM Peak Hr	LT	ST	RT	UT	Total	LT	ST	RT	UT	Total	Str. Tot.	LT	ST	RT	UT	Total	LT	ST	RT	UT	Total	Str. Tot.	Gr. Tot.	
0800-0900	104	0	0	0	104	0	0	63	0	63	167		0	0	0	0	0	2	0	3	0	5	5	172

PM Peak Hour Factor ➔ 0.88						Highest Hourly Vehicle Volume Between 1600h & 1800h																		
PM Peak Hr	LT	ST	RT	UT	Total	LT	ST	RT	UT	Total	Str. Tot.	LT	ST	RT	UT	Total	LT	ST	RT	UT	Total	Str. Tot.	Gr. Tot.	
1615-1715	3	0	0	0	3	0	0	4	0	4	7		0	0	0	0	0	39	0	88	0	127	127	134

Comments:
 Please refer to the traffic count at Bank Street and Laurier Avenue for through vehicle and heavy vehicle volumes on Laurier Avenue. Eastbound traffic backs up (AM peak period) from O'Connor Street and when this occurs, some eastbound left-turning motorists travel in the westbound lane to complete their turn. Westbound traffic backs up from Bank Street during the PM peak period.

- Notes:**
- Includes all vehicle types except bicycles, electric bicycles, and electric scooters.
 - When expansion and AADT factors are applied, the results will differ slightly due to rounding.

Appendix C

Synchro Intersection Worksheets – Existing Conditions

Lanes, Volumes, Timings

1: Bank Street & Slater Street /Slater Street

2023 Existing

AM Peak Hour

Lane Group	EBL	EBT	EBR	WBL	WBT	WBR	NBL	NBT	NBR	SBL	SBT	SBR
Lane Configurations		↕↕	↕					↕				↕
Traffic Volume (vph)	22	812	90	0	0	0	0	195	23	14	219	0
Future Volume (vph)	22	812	90	0	0	0	0	195	23	14	219	0
Satd. Flow (prot)	0	2784	1335	0	0	0	0	1408	0	0	1566	0
Fit Permitted		0.999									0.975	
Satd. Flow (perm)	0	2770	876	0	0	0	0	1408	0	0	1510	0
Satd. Flow (RTOR)			62					9				
Lane Group Flow (vph)	0	926	100	0	0	0	0	243	0	0	259	0
Turn Type	pm+pt	NA	Perm					NA	Perm	NA		
Protected Phases	5	2						4			8	
Permitted Phases	2		2							8		
Detector Phase	5	2	2					4		8	8	
Switch Phase												
Minimum Initial (s)	5.0	10.0	10.0					10.0	10.0	10.0		
Minimum Split (s)	10.0	24.0	24.0					35.0	35.0	35.0		
Total Split (s)	12.0	40.0	40.0					35.0	35.0	35.0		
Total Split (%)	16.0%	53.3%	53.3%					46.7%	46.7%	46.7%		
Yellow Time (s)	3.3	3.3	3.3					3.3	3.3	3.3		
All-Red Time (s)	1.7	1.7	1.7					2.2	2.2	2.2		
Lost Time Adjust (s)		0.0	0.0					0.0	0.0	0.0		
Total Lost Time (s)		5.0	5.0					5.5		5.5		
Lead/Lag	Lead										Lag	
Lead-Lag Optimize?	Yes										Yes	
Recall Mode	Max	C-Max	C-Max					Max	Max	Max		
Act Effct Green (s)		35.0	35.0					29.5		29.5		
Actuated g/C Ratio		0.47	0.47					0.39		0.39		
v/c Ratio		0.72	0.23					0.43		0.44		
Control Delay		19.9	7.0					12.3		19.6		
Queue Delay		0.0	0.0					0.0		0.0		
Total Delay		19.9	7.0					12.3		19.6		
LOS		B	A					B		B		
Approach Delay		18.6						12.3		19.6		
Approach LOS		B						B		B		
Queue Length 50th (m)		52.5	2.9					9.0		26.1		
Queue Length 95th (m)		73.5	11.1					m38.0		45.1		
Internal Link Dist (m)		64.9				157.3		81.5		43.1		
Turn Bay Length (m)			65.0									
Base Capacity (vph)		1293	441					559		593		
Starvation Cap Reductn		0	0					0		0		
Spillback Cap Reductn		0	0					0		0		
Storage Cap Reductn		0	0					0		0		
Reduced v/c Ratio		0.72	0.23					0.43		0.44		

Intersection Summary

Cycle Length: 75
 Actuated Cycle Length: 75
 Offset: 48 (64%), Referenced to phase 2:EBTL and 6:Hold, Start of Green
 Natural Cycle: 60
 Control Type: Actuated-Coordinated

Lanes, Volumes, Timings

1: Bank Street & Slater Street /Slater Street

2023 Existing

AM Peak Hour

Lane Group	Ø6
Lane Configurations	
Traffic Volume (vph)	
Future Volume (vph)	
Satd. Flow (prot)	
Fit Permitted	
Satd. Flow (perm)	
Satd. Flow (RTOR)	
Lane Group Flow (vph)	
Turn Type	
Protected Phases	6
Permitted Phases	
Detector Phase	
Switch Phase	
Minimum Initial (s)	1.0
Minimum Split (s)	3.0
Total Split (s)	28.0
Total Split (%)	37%
Yellow Time (s)	2.0
All-Red Time (s)	0.0
Lost Time Adjust (s)	
Total Lost Time (s)	
Lead/Lag	Lag
Lead-Lag Optimize?	Yes
Recall Mode	C-Max
Act Effct Green (s)	
Actuated g/C Ratio	
v/c Ratio	
Control Delay	
Queue Delay	
Total Delay	
LOS	
Approach Delay	
Approach LOS	
Queue Length 50th (m)	
Queue Length 95th (m)	
Internal Link Dist (m)	
Turn Bay Length (m)	
Base Capacity (vph)	
Starvation Cap Reductn	
Spillback Cap Reductn	
Storage Cap Reductn	
Reduced v/c Ratio	

Intersection Summary

Lanes, Volumes, Timings
1: Bank Street & Slater Street /Slater Street

2023 Existing
AM Peak Hour

Maximum v/c Ratio: 0.72	Intersection LOS: B
Intersection Signal Delay: 17.8	ICU Level of Service C
Intersection Capacity Utilization 66.1%	
Analysis Period (min) 15	

m Volume for 95th percentile queue is metered by upstream signal.

Splits and Phases: 1: Bank Street & Slater Street /Slater Street

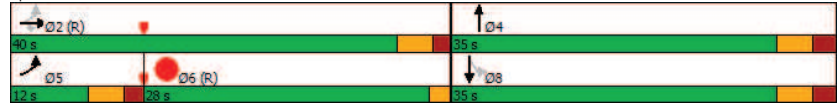

Lanes, Volumes, Timings
2: O'Connor Street & Slater Street

2023 Existing
AM Peak Hour

Lane Group	EBL	EBT	EBR	WBL	WBT	WBR	NBL	NBT	NBR	SBL	SBT	SBR
Lane Configurations		↑↑	↑							↓	↓↑	↓
Traffic Volume (vph)	0	637	55	0	0	0	0	0	0	119	235	0
Future Volume (vph)	0	637	55	0	0	0	0	0	0	119	235	0
Satd. Flow (prot)	0	2767	1297	0	0	0	0	0	0	1463	4165	0
Fit Permitted										0.950		
Satd. Flow (perm)	0	2767	1035	0	0	0	0	0	0	941	4165	0
Satd. Flow (RTOR)										51		
Lane Group Flow (vph)	0	708	61	0	0	0	0	0	0	132	261	0
Turn Type		NA	Perm							Perm	NA	
Protected Phases		4									6	
Permitted Phases			4									6
Detector Phase		4	4								6	6
Switch Phase												
Minimum Initial (s)		10.0	10.0							10.0	10.0	
Minimum Split (s)		30.5	30.5							22.5	22.5	
Total Split (s)		41.0	41.0							34.0	34.0	
Total Split (%)		54.7%	54.7%							45.3%	45.3%	
Yellow Time (s)		3.3	3.3							3.3	3.3	
All-Red Time (s)		2.2	2.2							2.2	2.2	
Lost Time Adjust (s)		0.0	0.0							0.0	0.0	
Total Lost Time (s)		5.5	5.5							5.5	5.5	
Lead/Lag												
Lead-Lag Optimize?												
Recall Mode		C-Max	C-Max							Max	Max	
Act Effct Green (s)		35.5	35.5							28.5	28.5	
Actuated g/C Ratio		0.47	0.47							0.38	0.38	
v/c Ratio		0.54	0.12							0.34	0.16	
Control Delay		2.6	1.8							13.3	15.7	
Queue Delay		0.0	0.0							0.0	0.0	
Total Delay		2.6	1.8							13.3	15.7	
LOS		A	A							B	B	
Approach Delay		2.5									14.9	
Approach LOS		A									B	
Queue Length 50th (m)		3.0	0.5							7.6	8.7	
Queue Length 95th (m)		3.8	m0.7							20.4	13.9	
Internal Link Dist (m)		157.3			58.3			84.2			37.7	
Turn Bay Length (m)			30.0									
Base Capacity (vph)		1309	489							389	1582	
Starvation Cap Reductn		0	0							0	0	
Spillback Cap Reductn		0	0							0	0	
Storage Cap Reductn		0	0							0	0	
Reduced v/c Ratio		0.54	0.12							0.34	0.16	

Intersection Summary

Cycle Length: 75
Actuated Cycle Length: 75
Offset: 48 (64%), Referenced to phase 4:EBT, Start of Green
Natural Cycle: 55
Control Type: Actuated-Coordinated

Lanes, Volumes, Timings
2: O'Connor Street & Slater Street

2023 Existing
AM Peak Hour

Maximum v/c Ratio: 0.54	Intersection LOS: A
Intersection Signal Delay: 6.7	ICU Level of Service A
Intersection Capacity Utilization 44.2%	
Analysis Period (min) 15	

m Volume for 95th percentile queue is metered by upstream signal.

Splits and Phases: 2: O'Connor Street & Slater Street

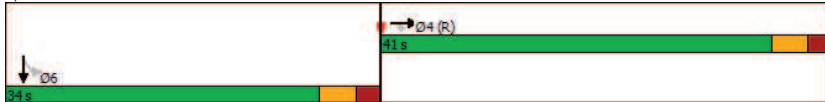

Lanes, Volumes, Timings
3: Bank Street & Laurier Avenue West

2023 Existing
AM Peak Hour

Lane Group	EBL	EBT	EBR	WBL	WBT	WBR	NBL	NBT	NBR	SBL	SBT	SBR
Lane Configurations		↖ ↗	↖ ↗		↖ ↗	↖ ↗		↖ ↗	↖ ↗		↖ ↗	↖ ↗
Traffic Volume (vph)	2	299	51	0	235	39	1	174	135	12	241	58
Future Volume (vph)	2	299	51	0	235	39	1	174	135	12	241	58
Satd. Flow (prot)	0	1566	1335	0	1352	0	0	1382	1335	0	1484	1335
Fit Permitted		0.998						0.999			0.986	
Satd. Flow (perm)	0	1561	498	0	1352	0	0	1378	479	0	1434	435
Satd. Flow (RTOR)												
Lane Group Flow (vph)	0	334	57	0	304	0	0	194	150	0	281	64
Turn Type	Perm	NA	Perm	NA	Perm	NA	Perm	NA	Perm	Perm	NA	Perm
Protected Phases					6			8			4	
Permitted Phases	2		2				8		8	4		4
Detector Phase	2	2	2		6		8	8	8	4	4	4
Switch Phase												
Minimum Initial (s)	10.0	10.0	10.0		10.0		10.0	10.0	10.0	10.0	10.0	10.0
Minimum Split (s)	23.9	23.9	23.9		23.9		23.6	23.6	23.6	23.6	23.6	23.6
Total Split (s)	27.0	27.0	27.0		27.0		38.0	38.0	38.0	38.0	38.0	38.0
Total Split (%)	36.0%	36.0%	36.0%		36.0%		50.7%	50.7%	50.7%	50.7%	50.7%	50.7%
Yellow Time (s)	3.3	3.3	3.3		3.3		3.3	3.3	3.3	3.3	3.3	3.3
All-Red Time (s)	2.6	2.6	2.6		2.6		2.3	2.3	2.3	2.3	2.3	2.3
Lost Time Adjust (s)		0.0	0.0		0.0		0.0	0.0	0.0	0.0	0.0	0.0
Total Lost Time (s)		5.9	5.9		5.9		5.6	5.6	5.6	5.6	5.6	5.6
Lead/Lag	Lag	Lag	Lag		Lag		Lag	Lag	Lag	Lag	Lag	Lag
Lead-Lag Optimize?	Yes	Yes	Yes		Yes		Yes	Yes	Yes	Yes	Yes	Yes
Recall Mode	C-Max	C-Max	C-Max		C-Max		Max	Max	Max	Max	Max	Max
Act Effct Green (s)	26.1	26.1	26.1		26.1		37.4	37.4	37.4	37.4	37.4	37.4
Actuated g/C Ratio	0.35	0.35	0.35		0.35		0.50	0.50	0.50	0.50	0.50	0.50
v/c Ratio	0.62	0.33	0.65		0.65		0.28	0.63	0.63	0.39	0.30	0.30
Control Delay	26.2	24.6	42.6		42.6		12.4	28.8	28.8	8.4	10.3	10.3
Queue Delay	0.0	0.0	0.0		0.0		0.0	0.0	0.0	0.0	0.0	0.0
Total Delay	26.2	24.6	42.6		42.6		12.4	28.8	28.8	8.4	10.3	10.3
LOS		C	C		D		B	C	C	A	B	B
Approach Delay	26.0				42.6		19.5			8.7		
Approach LOS		C			D		B			A		
Queue Length 50th (m)	38.5	5.8	43.5		43.5		15.1	14.6	14.6	11.6	2.6	2.6
Queue Length 95th (m)	64.3	15.8	68.2		68.2		27.6	#42.5	42.5	20.1	6.8	6.8
Internal Link Dist (m)	75.4		68.9		68.9		45.4			81.5		
Turn Bay Length (m)			45.0									10.0
Base Capacity (vph)		543	173		470		687	238	238	715	216	216
Starvation Cap Reductn	0	0	0		0		0	0	0	0	0	0
Spillback Cap Reductn	0	0	0		0		0	0	0	0	0	0
Storage Cap Reductn	0	0	0		0		0	0	0	0	0	0
Reduced v/c Ratio		0.62	0.33		0.65		0.28	0.63	0.63	0.39	0.30	0.30

Intersection Summary												
Cycle Length: 75												
Actuated Cycle Length: 75												
Offset: 40 (53%), Referenced to phase 2:EBTL and 6:WBT, Start of Green												
Natural Cycle: 55												
Control Type: Actuated-Coordinated												

Lanes, Volumes, Timings
3: Bank Street & Laurier Avenue West

2023 Existing
AM Peak Hour

Lane Group	Ø1	Ø3	Ø5	Ø7
Lane Configurations				
Traffic Volume (vph)				
Future Volume (vph)				
Satd. Flow (prot)				
Fit Permitted				
Satd. Flow (perm)				
Satd. Flow (RTOR)				
Lane Group Flow (vph)				
Turn Type				
Protected Phases	1	3	5	7
Permitted Phases				
Detector Phase				
Switch Phase				
Minimum Initial (s)	1.0	1.0	1.0	1.0
Minimum Split (s)	3.0	3.0	3.0	3.0
Total Split (s)	5.0	5.0	5.0	5.0
Total Split (%)	7%	7%	7%	7%
Yellow Time (s)	2.0	2.0	2.0	2.0
All-Red Time (s)	0.0	0.0	0.0	0.0
Lost Time Adjust (s)				
Total Lost Time (s)				
Lead/Lag	Lead	Lead	Lead	Lead
Lead-Lag Optimize?	Yes	Yes	Yes	Yes
Recall Mode	None	None	None	None
Act Effct Green (s)				
Actuated g/C Ratio				
v/c Ratio				
Control Delay				
Queue Delay				
Total Delay				
LOS				
Approach Delay				
Approach LOS				
Queue Length 50th (m)				
Queue Length 95th (m)				
Internal Link Dist (m)				
Turn Bay Length (m)				
Base Capacity (vph)				
Starvation Cap Reductn				
Spillback Cap Reductn				
Storage Cap Reductn				
Reduced v/c Ratio				
Intersection Summary				

Lanes, Volumes, Timings
3: Bank Street & Laurier Avenue West

2023 Existing
AM Peak Hour

Maximum v/c Ratio: 0.65
Intersection Signal Delay: 23.7
Intersection Capacity Utilization 67.0%
Analysis Period (min) 15
95th percentile volume exceeds capacity, queue may be longer.
Queue shown is maximum after two cycles.

Splits and Phases: 3: Bank Street & Laurier Avenue West

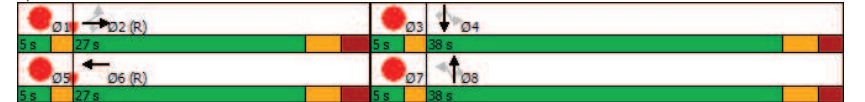

Lanes, Volumes, Timings
4: O'Connor Street & Laurier Avenue West

2023 Existing
AM Peak Hour

Lane Group	EBL	EBT	EBR	WBL	WBT	WBR	NBL	NBT	NBR	SBL	SBT	SBR
Lane Configurations		↔	↔	↔	↔						↔↔↔	
Traffic Volume (vph)	0	205	149	143	296	0	0	0	0	28	224	26
Future Volume (vph)	0	205	149	143	296	0	0	0	0	28	224	26
Satd. Flow (prot)	0	1251	0	1492	1511	0	0	0	0	0	3853	0
Fit Permitted				0.326							0.995	
Satd. Flow (perm)	0	1251	0	512	1511	0	0	0	0	0	3624	0
Satd. Flow (RTOR)												
Lane Group Flow (vph)	0	394	0	159	329	0	0	0	0	0	309	0
Turn Type		NA		pm+pt	NA					Perm	NA	
Protected Phases		2		9	6							4
Permitted Phases				6							4	
Detector Phase		2		9	6						4	4
Switch Phase												
Minimum Initial (s)		10.0		5.0	10.0					10.0	10.0	
Minimum Split (s)		16.9		10.8	16.9					16.7	16.7	
Total Split (s)		29.0		11.0	45.0					25.0	25.0	
Total Split (%)		38.7%		14.7%	60.0%					33.3%	33.3%	
Yellow Time (s)		3.3		3.3	3.3					3.3	3.3	
All-Red Time (s)		2.6		2.5	2.6					2.4	2.4	
Lost Time Adjust (s)		0.0		0.0	0.0						0.0	
Total Lost Time (s)		5.9		5.8	5.9						5.7	
Lead/Lag				Lead						Lag	Lag	
Lead-Lag Optimize?				Yes						Yes	Yes	
Recall Mode		C-Max		Max	C-Max					Max	Max	
Act Effct Green (s)		28.1		39.2	39.1						24.3	
Actuated g/C Ratio		0.37		0.52	0.52						0.32	
v/c Ratio		0.84		0.47	0.42						0.26	
Control Delay		36.2		14.9	13.0						9.5	
Queue Delay		0.0		0.0	0.0						0.0	
Total Delay		36.2		14.9	13.0						9.5	
LOS		D		B	B						A	
Approach Delay		36.2			13.7						9.5	
Approach LOS		D			B						A	
Queue Length 50th (m)		55.8		11.2	26.6						5.0	
Queue Length 95th (m)		#99.0		21.1	44.7						7.5	
Internal Link Dist (m)		64.2			50.7			45.5			84.2	
Turn Bay Length (m)				15.0								
Base Capacity (vph)		468		335	787						1174	
Starvation Cap Reductn		0		0	0						0	
Spillback Cap Reductn		0		0	0						0	
Storage Cap Reductn		0		0	0						0	
Reduced v/c Ratio		0.84		0.47	0.42						0.26	

Intersection Summary	
Cycle Length: 75	
Actuated Cycle Length: 75	
Offset: 63 (84%), Referenced to phase 2:EBT and 6:WBTL, Start of Green	
Natural Cycle: 70	
Control Type: Actuated-Coordinated	

Lanes, Volumes, Timings
4: O'Connor Street & Laurier Avenue West

2023 Existing
AM Peak Hour

Lane Group	Ø1	Ø3
Lane Configurations		
Traffic Volume (vph)		
Future Volume (vph)		
Satd. Flow (prot)		
Fit Permitted		
Satd. Flow (perm)		
Satd. Flow (RTOR)		
Lane Group Flow (vph)		
Turn Type		
Protected Phases	1	3
Permitted Phases		
Detector Phase		
Switch Phase		
Minimum Initial (s)	1.0	1.0
Minimum Split (s)	5.0	5.0
Total Split (s)	5.0	5.0
Total Split (%)	7%	7%
Yellow Time (s)	2.0	2.0
All-Red Time (s)	0.0	0.0
Lost Time Adjust (s)		
Total Lost Time (s)		
Lead/Lag	Lag	Lead
Lead-Lag Optimize?	Yes	Yes
Recall Mode	None	None
Act Effct Green (s)		
Actuated g/C Ratio		
v/c Ratio		
Control Delay		
Queue Delay		
Total Delay		
LOS		
Approach Delay		
Approach LOS		
Queue Length 50th (m)		
Queue Length 95th (m)		
Internal Link Dist (m)		
Turn Bay Length (m)		
Base Capacity (vph)		
Starvation Cap Reductn		
Spillback Cap Reductn		
Storage Cap Reductn		
Reduced v/c Ratio		

Intersection Summary	
Cycle Length: 75	
Actuated Cycle Length: 75	
Offset: 63 (84%), Referenced to phase 2:EBT and 6:WBTL, Start of Green	
Natural Cycle: 70	
Control Type: Actuated-Coordinated	

Lanes, Volumes, Timings
4: O'Connor Street & Laurier Avenue West

2023 Existing
AM Peak Hour

Maximum v/c Ratio: 0.84	Intersection LOS: C
Intersection Signal Delay: 20.0	ICU Level of Service B
Intersection Capacity Utilization 62.4%	
Analysis Period (min) 15	
# 95th percentile volume exceeds capacity, queue may be longer.	
Queue shown is maximum after two cycles.	

Splits and Phases: 4: O'Connor Street & Laurier Avenue West



HCM 2010 TWSC
5: Laurier Avenue West & Site Access #1

2023 Existing
AM Peak Hour

Intersection						
Int Delay, s/veh	1.3					
Movement	EBL	EBT	WBT	WBR	SBL	SBR
Lane Configurations		↕	↕		↕	↕
Traffic Vol, veh/h	104	446	332	63	2	3
Future Vol, veh/h	104	446	332	63	2	3
Conflicting Peds, #/hr	198	0	0	198	10	10
Sign Control	Free	Free	Free	Free	Stop	Stop
RT Channelized	-	None	-	None	-	None
Storage Length	-	-	-	-	0	-
Veh in Median Storage, #	-	0	0	-	0	-
Grade, %	-	0	0	-	0	-
Peak Hour Factor	90	90	90	90	90	90
Heavy Vehicles, %	2	2	2	2	2	2
Mvmt Flow	116	496	369	70	2	3

Major/Minor	Major1	Major2	Minor2
Conflicting Flow All	637	0	1340
Stage 1	-	-	602
Stage 2	-	-	738
Critical Hdwy	4.12	-	6.42
Critical Hdwy Stg 1	-	-	5.42
Critical Hdwy Stg 2	-	-	5.42
Follow-up Hdwy	2,218	-	3,518
Pot Cap-1 Maneuver	947	-	168
Stage 1	-	-	547
Stage 2	-	-	473
Platoon blocked, %	-	-	-
Mov Cap-1 Maneuver	772	-	89
Mov Cap-2 Maneuver	-	-	89
Stage 1	-	-	354
Stage 2	-	-	386

Approach	EB	WB	SB
HCM Control Delay, s	2	0	27.3
HCM LOS			D

Minor Lane/Major Mvmt	EBL	EBT	WBT	WBR	SBLn1
Capacity (veh/h)	772	-	-	-	167
HCM Lane V/C Ratio	0.15	-	-	-	0.033
HCM Control Delay (s)	10.5	0	-	-	27.3
HCM Lane LOS	B	A	-	-	D
HCM 95th %tile Q(veh)	0.5	-	-	-	0.1

Lanes, Volumes, Timings

1: Bank Street & Slater Street /Slater Street

2023 Existing

PM Peak Hour

Lane Group	EBL	EBT	EBR	WBL	WBT	WBR	NBL	NBT	NBR	SBL	SBT	SBR
Lane Configurations		↕↕	↕					↕				↕
Traffic Volume (vph)	25	775	154	0	0	0	0	230	19	13	222	0
Future Volume (vph)	25	775	154	0	0	0	0	230	19	13	222	0
Satd. Flow (prot)	0	2902	1335	0	0	0	0	1446	0	0	1461	0
Fit Permitted		0.998									0.978	
Satd. Flow (perm)	0	2880	940	0	0	0	0	1446	0	0	1416	0
Satd. Flow (RTOR)			43					6				
Lane Group Flow (vph)	0	889	171	0	0	0	0	277	0	0	261	0
Turn Type	pm+pt	NA	Perm					NA		Perm	NA	
Protected Phases	5	2						4			8	
Permitted Phases	2		2							8		
Detector Phase	5	2	2					4		8	8	
Switch Phase												
Minimum Initial (s)	5.0	10.0	10.0					10.0		10.0	10.0	
Minimum Split (s)	10.0	24.0	24.0					35.0		35.0	35.0	
Total Split (s)	12.0	40.0	40.0					35.0		35.0	35.0	
Total Split (%)	16.0%	53.3%	53.3%					46.7%		46.7%	46.7%	
Yellow Time (s)	3.3	3.3	3.3					3.3		3.3	3.3	
All-Red Time (s)	1.7	1.7	1.7					2.2		2.2	2.2	
Lost Time Adjust (s)		0.0	0.0					0.0		0.0	0.0	
Total Lost Time (s)		5.0	5.0					5.5		5.5	5.5	
Lead/Lag	Lead										Lag	
Lead-Lag Optimize?	Yes										Yes	
Recall Mode	Max	C-Max	C-Max					Max		Max	Max	
Act Effct Green (s)		35.0	35.0					29.5		29.5	29.5	
Actuated g/C Ratio		0.47	0.47					0.39		0.39	0.39	
v/c Ratio		0.66	0.37					0.48		0.47	0.47	
Control Delay		18.4	12.3					14.1		20.4	20.4	
Queue Delay		0.0	0.0					0.0		0.0	0.0	
Total Delay		18.4	12.3					14.1		20.4	20.4	
LOS		B	B					B		C	C	
Approach Delay		17.4						14.1		20.4	20.4	
Approach LOS		B						B		C	C	
Queue Length 50th (m)		48.4	10.6					14.7		26.7	26.7	
Queue Length 95th (m)		67.6	24.6					m21.6		46.7	46.7	
Internal Link Dist (m)		64.9				157.3		81.5		43.1	43.1	
Turn Bay Length (m)			65.0									
Base Capacity (vph)		1346	461					572		556	556	
Starvation Cap Reductn		0	0					0		0	0	
Spillback Cap Reductn		0	0					0		0	0	
Storage Cap Reductn		0	0					0		0	0	
Reduced v/c Ratio		0.66	0.37					0.48		0.47	0.47	

Intersection Summary

Cycle Length: 75
 Actuated Cycle Length: 75
 Offset: 20 (27%), Referenced to phase 2:EBTL and 6:Hold, Start of Green
 Natural Cycle: 60
 Control Type: Actuated-Coordinated

Lanes, Volumes, Timings

1: Bank Street & Slater Street /Slater Street

2023 Existing

PM Peak Hour

Lane Group	Ø6
Lane Configurations	
Traffic Volume (vph)	
Future Volume (vph)	
Satd. Flow (prot)	
Fit Permitted	
Satd. Flow (perm)	
Satd. Flow (RTOR)	
Lane Group Flow (vph)	
Turn Type	
Protected Phases	6
Permitted Phases	
Detector Phase	
Switch Phase	
Minimum Initial (s)	1.0
Minimum Split (s)	3.0
Total Split (s)	28.0
Total Split (%)	37%
Yellow Time (s)	2.0
All-Red Time (s)	0.0
Lost Time Adjust (s)	
Total Lost Time (s)	
Lead/Lag	Lag
Lead-Lag Optimize?	Yes
Recall Mode	C-Max
Act Effct Green (s)	
Actuated g/C Ratio	
v/c Ratio	
Control Delay	
Queue Delay	
Total Delay	
LOS	
Approach Delay	
Approach LOS	
Queue Length 50th (m)	
Queue Length 95th (m)	
Internal Link Dist (m)	
Turn Bay Length (m)	
Base Capacity (vph)	
Starvation Cap Reductn	
Spillback Cap Reductn	
Storage Cap Reductn	
Reduced v/c Ratio	

Intersection Summary

Lanes, Volumes, Timings
1: Bank Street & Slater Street /Slater Street

2023 Existing
PM Peak Hour

Maximum v/c Ratio: 0.66	Intersection LOS: B
Intersection Signal Delay: 17.3	ICU Level of Service C
Intersection Capacity Utilization 64.2%	
Analysis Period (min) 15	

m Volume for 95th percentile queue is metered by upstream signal.

Splits and Phases: 1: Bank Street & Slater Street /Slater Street

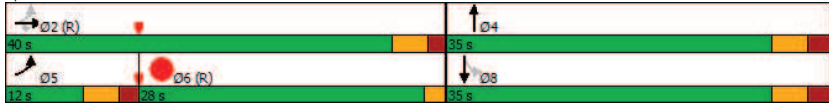

Lanes, Volumes, Timings
2: O'Connor Street & Slater Street

2023 Existing
PM Peak Hour

Lane Group	EBL	EBT	EBR	WBL	WBT	WBR	NBL	NBT	NBR	SBL	SBT	SBR
Lane Configurations		↑↑	↑							↓	↓↑↑	
Traffic Volume (vph)	0	747	61	0	0	0	0	0	0	105	356	0
Future Volume (vph)	0	747	61	0	0	0	0	0	0	105	356	0
Satd. Flow (prot)	0	2899	1322	0	0	0	0	0	0	1436	4288	0
Fit Permitted										0.950		
Satd. Flow (perm)	0	2899	1060	0	0	0	0	0	0	975	4288	0
Satd. Flow (RTOR)										53		
Lane Group Flow (vph)	0	830	68	0	0	0	0	0	0	117	396	0
Turn Type		NA	Perm							Perm	NA	
Protected Phases		4									6	
Permitted Phases			4									6
Detector Phase		4	4								6	6
Switch Phase												
Minimum Initial (s)		10.0	10.0							10.0	10.0	
Minimum Split (s)		30.5	30.5							22.5	22.5	
Total Split (s)		45.0	45.0							30.0	30.0	
Total Split (%)		60.0%	60.0%							40.0%	40.0%	
Yellow Time (s)		3.3	3.3							3.3	3.3	
All-Red Time (s)		2.2	2.2							2.2	2.2	
Lost Time Adjust (s)		0.0	0.0							0.0	0.0	
Total Lost Time (s)		5.5	5.5							5.5	5.5	
Lead/Lag												
Lead-Lag Optimize?												
Recall Mode		C-Max	C-Max							Max	Max	
Act Effct Green (s)		39.5	39.5							24.5	24.5	
Actuated g/C Ratio		0.53	0.53							0.33	0.33	
v/c Ratio		0.54	0.12							0.33	0.28	
Control Delay		3.8	3.0							14.2	19.4	
Queue Delay		0.0	0.0							0.0	0.0	
Total Delay		3.8	3.0							14.2	19.4	
LOS		A	A							B	B	
Approach Delay		3.7									18.2	
Approach LOS		A									B	
Queue Length 50th (m)		6.6	1.0							6.4	15.0	
Queue Length 95th (m)		8.2	m1.6							18.8	22.2	
Internal Link Dist (m)		157.3				58.3		84.2			37.7	
Turn Bay Length (m)			30.0									
Base Capacity (vph)		1526	558							354	1400	
Starvation Cap Reductn		0	0							0	0	
Spillback Cap Reductn		0	0							0	0	
Storage Cap Reductn		0	0							0	0	
Reduced v/c Ratio		0.54	0.12							0.33	0.28	

Intersection Summary

Cycle Length: 75
Actuated Cycle Length: 75
Offset: 12 (16%), Referenced to phase 4:EBT, Start of Green
Natural Cycle: 55
Control Type: Actuated-Coordinated

Lanes, Volumes, Timings
2: O'Connor Street & Slater Street

2023 Existing
PM Peak Hour

Maximum v/c Ratio: 0.54	Intersection LOS: A
Intersection Signal Delay: 9.0	ICU Level of Service A
Intersection Capacity Utilization 47.6%	
Analysis Period (min) 15	
m Volume for 95th percentile queue is metered by upstream signal.	

Splits and Phases: 2: O'Connor Street & Slater Street

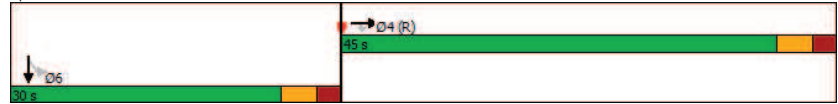

Lanes, Volumes, Timings
3: Bank Street & Laurier Avenue West

2023 Existing
PM Peak Hour

Lane Group	EBL	EBT	EBR	WBL	WBT	WBR	NBL	NBT	NBR	SBL	SBT	SBR
Lane Configurations		↕	↕		↕			↕	↕		↕	↕
Traffic Volume (vph)	0	228	80	2	281	79	1	187	77	18	285	76
Future Volume (vph)	0	228	80	2	281	79	1	187	77	18	285	76
Satd. Flow (prot)	0	1571	1335	0	1326	0	0	1491	1335	0	1538	1335
Fit Permitted					0.999			0.999			0.977	
Satd. Flow (perm)	0	1571	471	0	1323	0	0	1487	223	0	1453	261
Satd. Flow (RTOR)												
Lane Group Flow (vph)	0	253	89	0	402	0	0	209	86	0	337	84
Turn Type		NA	Perm	Perm	NA		Perm	NA	Perm	Perm	NA	Perm
Protected Phases					6			8			4	
Permitted Phases	2		2	6			8		8	4		4
Detector Phase	2	2	2	6	6		8	8	8	4	4	4
Switch Phase												
Minimum Initial (s)	10.0	10.0	10.0	10.0	10.0		10.0	10.0	10.0	10.0	10.0	10.0
Minimum Split (s)	23.9	23.9	23.9	23.9	23.9		23.6	23.6	23.6	23.6	23.6	23.6
Total Split (s)	30.0	30.0	30.0	30.0	30.0		35.0	35.0	35.0	35.0	35.0	35.0
Total Split (%)	40.0%	40.0%	40.0%	40.0%	40.0%		46.7%	46.7%	46.7%	46.7%	46.7%	46.7%
Yellow Time (s)	3.3	3.3	3.3	3.3	3.3		3.3	3.3	3.3	3.3	3.3	3.3
All-Red Time (s)	2.6	2.6	2.6	2.6	2.6		2.3	2.3	2.3	2.3	2.3	2.3
Lost Time Adjust (s)		0.0	0.0		0.0			0.0	0.0		0.0	0.0
Total Lost Time (s)		5.9	5.9		5.9			5.6	5.6		5.6	5.6
Lead/Lag	Lag	Lag	Lag	Lag	Lag		Lag	Lag	Lag	Lag	Lag	Lag
Lead-Lag Optimize?	Yes	Yes	Yes	Yes	Yes		Yes	Yes	Yes	Yes	Yes	Yes
Recall Mode	C-Max	C-Max	C-Max	C-Max	C-Max		Max	Max	Max	Max	Max	Max
Act Effct Green (s)	29.1	29.1	29.1	29.1	29.1		34.4	34.4	34.4	34.4	34.4	34.4
Actuated g/C Ratio	0.39	0.39		0.39			0.46	0.46		0.46	0.46	0.46
v/c Ratio	0.42	0.49		0.78			0.31	0.84		0.51	0.71	
Control Delay	19.4	28.6		26.2			14.4	80.6		12.8	45.0	
Queue Delay	0.0	0.0		0.0			0.0	0.0		0.3	0.0	
Total Delay	19.4	28.6		26.2			14.4	80.6		13.1	45.0	
LOS	B	C		C			B	F		B	D	
Approach Delay	21.8			26.2			33.7			19.5		
Approach LOS	C			C			C			B		
Queue Length 50th (m)	25.5	9.2		28.1			17.8	10.2		21.7	5.7	
Queue Length 95th (m)	43.9	23.9		#88.4			31.9	#36.6		34.3	#32.4	
Internal Link Dist (m)	75.4			68.9			45.4			81.5		
Turn Bay Length (m)			45.0									10.0
Base Capacity (vph)		609	182		513		682	102		666	119	
Starvation Cap Reductn		0	0		0		0	0		55	0	
Spillback Cap Reductn		0	0		0		0	0		0	0	
Storage Cap Reductn		0	0		0		0	0		0	0	
Reduced v/c Ratio		0.42	0.49		0.78		0.31	0.84		0.55	0.71	

Intersection Summary												
Cycle Length: 75												
Actuated Cycle Length: 75												
Offset: 11 (15%), Referenced to phase 2:EBTL and 6:WBTL, Start of Green												
Natural Cycle: 55												
Control Type: Actuated-Coordinated												

Lanes, Volumes, Timings
 3: Bank Street & Laurier Avenue West

2023 Existing
 PM Peak Hour

Lane Group	Ø1	Ø3	Ø5	Ø7
Lane Configurations				
Traffic Volume (vph)				
Future Volume (vph)				
Satd. Flow (prot)				
Fit Permitted				
Satd. Flow (perm)				
Satd. Flow (RTOR)				
Lane Group Flow (vph)				
Turn Type				
Protected Phases	1	3	5	7
Permitted Phases				
Detector Phase				
Switch Phase				
Minimum Initial (s)	1.0	1.0	1.0	1.0
Minimum Split (s)	3.0	3.0	3.0	3.0
Total Split (s)	5.0	5.0	5.0	5.0
Total Split (%)	7%	7%	7%	7%
Yellow Time (s)	2.0	2.0	2.0	2.0
All-Red Time (s)	0.0	0.0	0.0	0.0
Lost Time Adjust (s)				
Total Lost Time (s)				
Lead/Lag	Lead	Lead	Lead	Lead
Lead-Lag Optimize?	Yes	Yes	Yes	Yes
Recall Mode	None	None	None	None
Act Effct Green (s)				
Actuated g/C Ratio				
v/c Ratio				
Control Delay				
Queue Delay				
Total Delay				
LOS				
Approach Delay				
Approach LOS				
Queue Length 50th (m)				
Queue Length 95th (m)				
Internal Link Dist (m)				
Turn Bay Length (m)				
Base Capacity (vph)				
Starvation Cap Reductn				
Spillback Cap Reductn				
Storage Cap Reductn				
Reduced v/c Ratio				
Intersection Summary				

Lanes, Volumes, Timings
 3: Bank Street & Laurier Avenue West

2023 Existing
 PM Peak Hour

Maximum v/c Ratio: 0.84	
Intersection Signal Delay: 24.7	Intersection LOS: C
Intersection Capacity Utilization 72.4%	ICU Level of Service C
Analysis Period (min) 15	
# 95th percentile volume exceeds capacity, queue may be longer.	
Queue shown is maximum after two cycles.	

Splits and Phases: 3: Bank Street & Laurier Avenue West

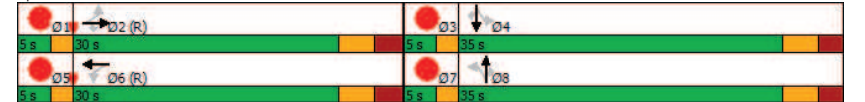

Lanes, Volumes, Timings
4: O'Connor Street & Laurier Avenue West

2023 Existing
PM Peak Hour

Lane Group	EBL	EBT	EBR	WBL	WBT	WBR	NBL	NBT	NBR	SBL	SBT	SBR
Lane Configurations		↔		↔	↔					↔↔↔		
Traffic Volume (vph)	0	253	104	194	279	0	0	0	0	55	344	31
Future Volume (vph)	0	253	104	194	279	0	0	0	0	55	344	31
Satd. Flow (prot)	0	1337	0	1492	1571	0	0	0	0	0	4019	0
Fit Permitted				0.323							0.994	
Satd. Flow (perm)	0	1337	0	507	1571	0	0	0	0	0	3711	0
Satd. Flow (RTOR)												
Lane Group Flow (vph)	0	397	0	216	310	0	0	0	0	0	477	0
Turn Type		NA		pm+pt	NA					Perm	NA	
Protected Phases		2		9	6							4
Permitted Phases				6						4		
Detector Phase		2		9	6					4		4
Switch Phase												
Minimum Initial (s)		10.0		5.0	10.0					10.0	10.0	
Minimum Split (s)		16.9		10.8	16.9					16.7	16.7	
Total Split (s)		29.0		11.0	45.0					25.0	25.0	
Total Split (%)		38.7%		14.7%	60.0%					33.3%	33.3%	
Yellow Time (s)		3.3		3.3	3.3					3.3	3.3	
All-Red Time (s)		2.6		2.5	2.6					2.4	2.4	
Lost Time Adjust (s)		0.0		0.0	0.0						0.0	
Total Lost Time (s)		5.9		5.8	5.9						5.7	
Lead/Lag				Lead						Lag	Lag	
Lead-Lag Optimize?				Yes						Yes	Yes	
Recall Mode		C-Max		Max	C-Max					Max	Max	
Act Effct Green (s)		28.1		39.2	39.1						24.3	
Actuated g/C Ratio		0.37		0.52	0.52						0.32	
v/c Ratio		0.79		0.65	0.38						0.40	
Control Delay		27.3		21.6	12.4						10.8	
Queue Delay		0.0		0.0	0.0						0.0	
Total Delay		27.3		21.6	12.4						10.8	
LOS		C		C	B						B	
Approach Delay		27.3			16.2						10.8	
Approach LOS		C			B						B	
Queue Length 50th (m)		53.7		15.9	24.4						8.2	
Queue Length 95th (m)		m#89.8		#30.3	41.1						10.5	
Internal Link Dist (m)		64.2			50.7			45.5			84.2	
Turn Bay Length (m)				15.0								
Base Capacity (vph)		500		333	819						1202	
Starvation Cap Reductn		0		0	0						0	
Spillback Cap Reductn		0		0	0						0	
Storage Cap Reductn		0		0	0						0	
Reduced v/c Ratio		0.79		0.65	0.38						0.40	

Intersection Summary												
Cycle Length: 75												
Actuated Cycle Length: 75												
Offset: 22 (29%), Referenced to phase 2:EBT and 6:WBTL, Start of Green												
Natural Cycle: 70												
Control Type: Actuated-Coordinated												

Lanes, Volumes, Timings
4: O'Connor Street & Laurier Avenue West

2023 Existing
PM Peak Hour

Lane Group	Ø1	Ø3
Lane Configurations		
Traffic Volume (vph)		
Future Volume (vph)		
Satd. Flow (prot)		
Fit Permitted		
Satd. Flow (perm)		
Satd. Flow (RTOR)		
Lane Group Flow (vph)		
Turn Type		
Protected Phases	1	3
Permitted Phases		
Detector Phase		
Switch Phase		
Minimum Initial (s)	1.0	1.0
Minimum Split (s)	5.0	5.0
Total Split (s)	5.0	5.0
Total Split (%)	7%	7%
Yellow Time (s)	2.0	2.0
All-Red Time (s)	0.0	0.0
Lost Time Adjust (s)		
Total Lost Time (s)		
Lead/Lag	Lag	Lead
Lead-Lag Optimize?	Yes	Yes
Recall Mode	None	None
Act Effct Green (s)		
Actuated g/C Ratio		
v/c Ratio		
Control Delay		
Queue Delay		
Total Delay		
LOS		
Approach Delay		
Approach LOS		
Queue Length 50th (m)		
Queue Length 95th (m)		
Internal Link Dist (m)		
Turn Bay Length (m)		
Base Capacity (vph)		
Starvation Cap Reductn		
Spillback Cap Reductn		
Storage Cap Reductn		
Reduced v/c Ratio		

Intersection Summary		
Cycle Length: 75		
Actuated Cycle Length: 75		
Offset: 22 (29%), Referenced to phase 2:EBT and 6:WBTL, Start of Green		
Natural Cycle: 70		
Control Type: Actuated-Coordinated		

Lanes, Volumes, Timings
4: O'Connor Street & Laurier Avenue West

2023 Existing
PM Peak Hour

Maximum v/c Ratio: 0.79
 Intersection Signal Delay: 17.5 Intersection LOS: B
 Intersection Capacity Utilization 65.4% ICU Level of Service C
 Analysis Period (min) 15
 # 95th percentile volume exceeds capacity, queue may be longer.
 Queue shown is maximum after two cycles.
 m Volume for 95th percentile queue is metered by upstream signal.

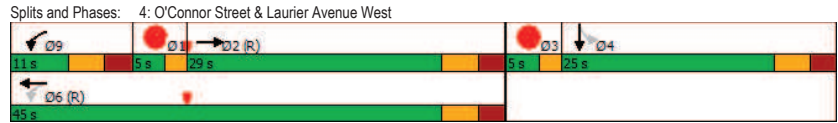

HCM 2010 TWSC
5: Laurier Avenue West & Site Access #1

2023 Existing
PM Peak Hour

Intersection						
Int Delay, s/veh	4.2					
Movement	EBL	EBT	WBT	WBR	SBL	SBR
Lane Configurations		↔	↔		↔	↔
Traffic Vol, veh/h	3	323	310	4	39	88
Future Vol, veh/h	3	323	310	4	39	88
Conflicting Peds, #/hr	198	0	0	198	10	10
Sign Control	Free	Free	Free	Free	Stop	Stop
RT Channelized	-	None	-	None	-	None
Storage Length	-	-	-	-	0	-
Veh in Median Storage, #	-	0	0	-	0	-
Grade, %	-	0	0	-	0	-
Peak Hour Factor	90	90	90	90	90	90
Heavy Vehicles, %	2	2	2	2	2	2
Mvmt Flow	3	359	344	4	43	98
Major/Minor	Major1	Major2	Minor2			
Conflicting Flow All	546	0	0	919	554	
Stage 1	-	-	-	544	-	
Stage 2	-	-	-	375	-	
Critical Hdwy	4.12	-	-	6.42	6.22	
Critical Hdwy Stg 1	-	-	-	5.42	-	
Critical Hdwy Stg 2	-	-	-	5.42	-	
Follow-up Hdwy	2,218	-	-	3,518	3,318	
Pot Cap-1 Maneuver	1023	-	-	301	532	
Stage 1	-	-	-	582	-	
Stage 2	-	-	-	695	-	
Platoon blocked, %	-	-	-	-	-	
Mov Cap-1 Maneuver	834	-	-	200	430	
Mov Cap-2 Maneuver	-	-	-	200	-	
Stage 1	-	-	-	473	-	
Stage 2	-	-	-	567	-	
Approach	EB	WB	SB			
HCM Control Delay, s	0.1	0	25			
HCM LOS			D			
Minor Lane/Major Mvmt	EBL	EBT	WBT	WBR	SBLn1	
Capacity (veh/h)	834	-	-	-	318	
HCM Lane V/C Ratio	0.004	-	-	-	0.444	
HCM Control Delay (s)	9.3	0	-	-	25	
HCM Lane LOS	A	A	-	-	D	
HCM 95th %tile Q(veh)	0	-	-	-	2.2	

Appendix D

Collision Data

Accident Date	Accident Year	Accident Time	Location	Environment Condition	Light	Traffic Control	Traffic Control Condition	Classification Of Accident	Initial Impact Type	Road Surface Condition	# Vehicles	# Motorcycles	# Bicycles	# Pedestrians
9/28/2016	2016	15:46	SLATER ST btwn BANK ST & O'CONNOR ST (_32A35K)	01 - Clear	01 - Daylight	10 - No control	0	03 - P-D only	99 - Other	01 - Dry	2	0	0	0
10/26/2016	2016	7:00	SLATER ST btwn BANK ST & O'CONNOR ST (_32A35K)	01 - Clear	03 - Dawn	10 - No control	0	03 - P-D only	04 - Sideswipe	01 - Dry	2	0	0	0
1/26/2016	2016	13:15	BANK ST @ SLATER ST (0002223)	01 - Clear	01 - Daylight	01 - Traffic signal	01 - Functioning	03 - P-D only	04 - Sideswipe	02 - Wet	2	0	0	0
2/12/2016	2016	17:11	O'CONNOR ST @ SLATER ST (0002230)	03 - Snow	07 - Dark	01 - Traffic signal	01 - Functioning	03 - P-D only	03 - Rear end	03 - Loose snow	2	0	0	0
12/29/2016	2016	13:42	BANK ST @ SLATER ST (0002223)	03 - Snow	01 - Daylight	01 - Traffic signal	00 - Unknown	02 - Non-fatal injury	03 - Rear end	03 - Loose snow	2	0	0	0
4/25/2016	2016	18:26	SLATER ST btwn BANK ST & O'CONNOR ST (_32A35K)	01 - Clear	01 - Daylight	10 - No control	0	03 - P-D only	03 - Rear end	03 - Loose snow	2	0	0	0
4/25/2016	2016	9:45	BANK ST @ SLATER ST (0002223)	01 - Clear	01 - Daylight	01 - Traffic signal	01 - Functioning	03 - P-D only	04 - Sideswipe	01 - Dry	2	0	0	0
6/10/2016	2016	15:16	SLATER ST btwn BANK ST & O'CONNOR ST (_32A35K)	01 - Clear	01 - Daylight	10 - No control	0	02 - Non-fatal injury	07 - SMV other	01 - Dry	1	0	0	1
6/18/2016	2016	19:48	SLATER ST btwn BANK ST & O'CONNOR ST (_32A35K)	01 - Clear	01 - Daylight	10 - No control	0	03 - P-D only	04 - Sideswipe	01 - Dry	2	0	0	0
7/18/2016	2016	14:18	O'CONNOR ST @ SLATER ST (0002230)	01 - Clear	01 - Daylight	01 - Traffic signal	01 - Functioning	03 - P-D only	04 - Sideswipe	01 - Dry	2	0	0	0
7/26/2016	2016	19:35	O'CONNOR ST @ SLATER ST (0002230)	01 - Clear	01 - Daylight	01 - Traffic signal	01 - Functioning	03 - P-D only	02 - Angle	01 - Dry	2	0	0	0
7/27/2016	2016	12:10	O'CONNOR ST @ SLATER ST (0002230)	01 - Clear	01 - Daylight	01 - Traffic signal	01 - Functioning	02 - Non-fatal injury	07 - SMV other	01 - Dry	1	0	0	1
1/19/2016	2016	12:00	O'CONNOR ST @ SLATER ST (0002230)	01 - Clear	01 - Daylight	01 - Traffic signal	01 - Functioning	03 - P-D only	05 - Turning movement	02 - Wet	2	0	0	0
8/7/2016	2016	1:08	BANK ST @ SLATER ST (0002223)	01 - Clear	07 - Dark	01 - Traffic signal	01 - Functioning	03 - P-D only	02 - Angle	01 - Dry	2	0	0	0
9/2/2016	2016	10:30	BANK ST @ SLATER ST (0002223)	01 - Clear	01 - Daylight	01 - Traffic signal	01 - Functioning	03 - P-D only	04 - Sideswipe	01 - Dry	2	0	0	0
1/21/2016	2016	16:23	BANK ST @ SLATER ST (0002223)	01 - Clear	01 - Daylight	01 - Traffic signal	01 - Functioning	03 - P-D only	04 - Sideswipe	02 - Wet	2	0	0	0
11/14/2017	2017	13:41	O'CONNOR ST @ SLATER ST (0002230)	01 - Clear	01 - Daylight	01 - Traffic signal	01 - Functioning	03 - P-D only	04 - Sideswipe	01 - Dry	2	0	0	0
1/30/2017	2017	19:03	O'CONNOR ST @ SLATER ST (0002230)	01 - Clear	07 - Dark	01 - Traffic signal	01 - Functioning	03 - P-D only	03 - Rear end	01 - Dry	2	0	0	0
12/19/2017	2017	17:33	BANK ST @ SLATER ST (0002223)	03 - Snow	07 - Dark	01 - Traffic signal	01 - Functioning	03 - P-D only	03 - Rear end	02 - Wet	2	0	0	0
12/18/2017	2017	9:24	BANK ST @ SLATER ST (0002223)	03 - Snow	01 - Daylight	01 - Traffic signal	01 - Functioning	02 - Non-fatal injury	03 - Rear end	04 - Slush	2	0	0	0
2/7/2017	2017	15:21	SLATER ST btwn BANK ST & O'CONNOR ST (_32A35K)	01 - Clear	01 - Daylight	10 - No control	0	03 - P-D only	04 - Sideswipe	02 - Wet	2	0	0	0
5/8/2017	2017	14:08	BANK ST @ SLATER ST (0002223)	01 - Clear	01 - Daylight	01 - Traffic signal	01 - Functioning	03 - P-D only	03 - Rear end	02 - Wet	2	0	0	0
1/16/2017	2017	14:52	O'CONNOR ST @ SLATER ST (0002230)	01 - Clear	01 - Daylight	01 - Traffic signal	01 - Functioning	03 - P-D only	04 - Sideswipe	01 - Dry	2	0	0	0
6/29/2017	2017	16:35	BANK ST @ SLATER ST (0002223)	02 - Rain	01 - Daylight	01 - Traffic signal	01 - Functioning	03 - P-D only	04 - Sideswipe	02 - Wet	2	0	0	0
1/15/2017	2017	6:18	BANK ST @ SLATER ST (0002223)	01 - Clear	07 - Dark	01 - Traffic signal	01 - Functioning	02 - Non-fatal injury	02 - Angle	02 - Wet	2	0	0	0
6/18/2017	2017	22:30	SLATER ST btwn BANK ST & O'CONNOR ST (_32A35K)	01 - Clear	07 - Dark	10 - No control	0	03 - P-D only	06 - SMV unattended vehicle	01 - Dry	1	0	0	0
7/25/2017	2017	5:54	O'CONNOR ST @ SLATER ST (0002230)	02 - Rain	03 - Dawn	01 - Traffic signal	01 - Functioning	03 - P-D only	05 - Turning movement	02 - Wet	2	0	0	0
9/25/2017	2017	2:24	BANK ST @ SLATER ST (0002223)	01 - Clear	07 - Dark	01 - Traffic signal	01 - Functioning	02 - Non-fatal injury	03 - Rear end	01 - Dry	2	0	0	0
11/2/2018	2018	18:35	O'CONNOR ST @ SLATER ST (0002230)	02 - Rain	07 - Dark	01 - Traffic signal	01 - Functioning	03 - P-D only	04 - Sideswipe	02 - Wet	2	0	0	0
11/21/2018	2018	8:15	SLATER ST btwn BANK ST & O'CONNOR ST (_32A35K)	01 - Clear	01 - Daylight	10 - No control	0	03 - P-D only	03 - Rear end	02 - Wet	2	0	0	0
1/30/2018	2018	17:09	SLATER ST btwn BANK ST & O'CONNOR ST (_32A35K)	01 - Clear	05 - Dusk	10 - No control	0	03 - P-D only	04 - Sideswipe	01 - Dry	2	0	0	0
3/25/2018	2018	13:30	O'CONNOR ST @ SLATER ST (0002230)	01 - Clear	01 - Daylight	01 - Traffic signal	01 - Functioning	03 - P-D only	02 - Angle	01 - Dry	2	0	0	0
6/15/2018	2018	14:13	O'CONNOR ST @ SLATER ST (0002230)	01 - Clear	01 - Daylight	01 - Traffic signal	01 - Functioning	03 - P-D only	05 - Turning movement	01 - Dry	2	0	0	0
1/2/2018	2018	14:15	SLATER ST btwn BANK ST & O'CONNOR ST (_32A35K)	03 - Snow	01 - Daylight	10 - No control	0	03 - P-D only	03 - Rear end	05 - Packed snow	2	0	0	0
9/11/2018	2018	17:50	BANK ST @ SLATER ST (0002223)	01 - Clear	01 - Daylight	01 - Traffic signal	00 - Unknown	03 - P-D only	04 - Sideswipe	01 - Dry	2	0	0	0
10/17/2018	2018	20:23	BANK ST @ SLATER ST (0002223)	01 - Clear	01 - Daylight	01 - Traffic signal	01 - Functioning	02 - Non-fatal injury	07 - SMV other	01 - Dry	2	0	0	0
1/21/2019	2019	16:25	BANK ST @ SLATER ST (0002223)	01 - Clear	01 - Daylight	01 - Traffic signal	01 - Functioning	03 - P-D only	04 - Sideswipe	05 - Packed snow	2	0	0	0
10/1/2019	2019	5:50	BANK ST @ SLATER ST (0002223)	02 - Rain	07 - Dark	01 - Traffic signal	01 - Functioning	02 - Non-fatal injury	07 - SMV other	02 - Wet	1	0	0	1
12/4/2019	2019	10:14	O'CONNOR ST @ SLATER ST (0002230)	02 - Rain	01 - Daylight	01 - Traffic signal	01 - Functioning	03 - P-D only	04 - Sideswipe	02 - Wet	2	0	0	0
12/2/2019	2019	18:21	O'CONNOR ST @ SLATER ST (0002230)	01 - Clear	07 - Dark	01 - Traffic signal	01 - Functioning	03 - P-D only	03 - Rear end	01 - Dry	2	0	0	0
12/13/2019	2019	15:00	O'CONNOR ST @ SLATER ST (0002230)	01 - Clear	01 - Daylight	01 - Traffic signal	01 - Functioning	02 - Non-fatal injury	07 - SMV other	01 - Dry	2	0	0	0
12/30/2019	2019	15:46	O'CONNOR ST @ SLATER ST (0002230)	03 - Snow	01 - Daylight	01 - Traffic signal	01 - Functioning	02 - Non-fatal injury	02 - Angle	03 - Loose snow	2	0	0	0
4/1/2019	2019	11:53	BANK ST @ SLATER ST (0002223)	01 - Clear	01 - Daylight	01 - Traffic signal	01 - Functioning	03 - P-D only	02 - Angle	01 - Dry	2	0	0	0
3/20/2019	2019	9:03	BANK ST @ SLATER ST (0002223)	01 - Clear	01 - Daylight	01 - Traffic signal	01 - Functioning	03 - P-D only	05 - Turning movement	01 - Dry	2	0	0	0
5/21/2019	2019	6:00	O'CONNOR ST @ SLATER ST (0002230)	01 - Clear	01 - Daylight	01 - Traffic signal	01 - Functioning	03 - P-D only	04 - Sideswipe	01 - Dry	2	0	0	0
5/12/2019	2019	15:53	O'CONNOR ST @ SLATER ST (0002230)	01 - Clear	01 - Daylight	01 - Traffic signal	01 - Functioning	03 - P-D only	04 - Sideswipe	01 - Dry	2	0	0	0
5/29/2019	2019	16:30	BANK ST @ SLATER ST (0002223)	01 - Clear	01 - Daylight	01 - Traffic signal	01 - Functioning	03 - P-D only	03 - Rear end	01 - Dry	2	0	0	0
6/13/2019	2019	14:32	O'CONNOR ST @ SLATER ST (0002230)	01 - Clear	01 - Daylight	01 - Traffic signal	01 - Functioning	03 - P-D only	04 - Sideswipe	01 - Dry	2	0	0	0
6/11/2019	2019	20:47	BANK ST @ SLATER ST (0002223)	01 - Clear	05 - Dusk	01 - Traffic signal	01 - Functioning	03 - P-D only	09 - Other	01 - Dry	2	0	0	0
7/19/2019	2019	11:56	BANK ST @ SLATER ST (0002223)	01 - Clear	01 - Daylight	01 - Traffic signal	01 - Functioning	03 - P-D only	04 - Sideswipe	01 - Dry	2	0	0	0
7/21/2019	2019	13:15	O'CONNOR ST @ SLATER ST (0002230)	01 - Clear	01 - Daylight	01 - Traffic signal	01 - Functioning	03 - P-D only	04 - Sideswipe	01 - Dry	2	0	0	0
12/31/2020	2020	12:27	BANK ST @ SLATER ST (0002223)	01 - Clear	01 - Daylight	01 - Traffic signal	00 - Unknown	03 - P-D only	04 - Sideswipe	02 - Wet	2	0	0	0
2/26/2020	2020	15:50	O'CONNOR ST @ SLATER ST (0002230)	01 - Clear	01 - Daylight	01 - Traffic signal	01 - Functioning	02 - Non-fatal injury	07 - SMV other	01 - Dry	1	0	0	1
6/23/2020	2020	9:08	O'CONNOR ST @ SLATER ST (0002230)	01 - Clear	01 - Daylight	01 - Traffic signal	01 - Functioning	02 - Non-fatal injury	07 - SMV other	01 - Dry	2	0	0	1
10/26/2020	2020	13:49	O'CONNOR ST @ SLATER ST (0002230)	01 - Clear	01 - Daylight	01 - Traffic signal	01 - Functioning	03 - P-D only	02 - Angle	02 - Wet	2	0	0	0
10/31/2020	2020	20:39	O'CONNOR ST @ SLATER ST (0002230)	01 - Clear	07 - Dark	01 - Traffic signal	01 - Functioning	03 - P-D only	02 - Angle	01 - Dry	2	0	0	0
10/19/2016	2016	9:50	LAURIER AVE @ O'CONNOR ST (0002224)	01 - Clear	01 - Daylight	01 - Traffic signal	01 - Functioning	03 - P-D only	04 - Sideswipe	01 - Dry	2	0	0	0
11/15/2016	2016	10:45	LAURIER AVE @ O'CONNOR ST (0002224)	01 - Clear	01 - Daylight	01 - Traffic signal	01 - Functioning	03 - P-D only	04 - Sideswipe	01 - Dry	2	0	0	0
11/8/2016	2016	8:14	LAURIER AVE @ O'CONNOR ST (0002224)	01 - Clear	01 - Daylight	01 - Traffic signal	00 - Unknown	03 - P-D only	04 - Sideswipe	01 - Dry	2	0	0	0
10/24/2016	2016	13:16	LAURIER AVE W btwn BANK ST & O'CONNOR ST (_32A348)	01 - Clear	01 - Daylight	10 - No control	0	03 - P-D only	03 - Rear end	01 - Dry	2	0	0	0
4/16/2016	2016	18:45	LAURIER AVE W btwn BANK ST & O'CONNOR ST (_32A348)	01 - Clear	05 - Dusk	10 - No control	0	03 - P-D only	06 - SMV unattended vehicle	01 - Dry	1	0	0	0
1/13/2016	2016	15:35	LAURIER AVE @ O'CONNOR ST (0002224)	01 - Clear	01 - Daylight	01 - Traffic signal	01 - Functioning	03 - P-D only	05 - Turning movement	03 - Loose snow	2	0	0	0
6/29/2016	2016	7:22	LAURIER AVE @ O'CONNOR ST (0002224)	01 - Clear	01 - Daylight	01 - Traffic signal	01 - Functioning	02 - Non-fatal injury	05 - Turning movement	01 - Dry	2	0	0	0
8/8/2016	2016	16:44	LAURIER AVE @ O'CONNOR ST (0002224)	01 - Clear	01 - Daylight	01 - Traffic signal	01 - Functioning	03 - P-D only	05 - Turning movement	01 - Dry	2	0	1	0
9/9/2016	2016	15:34	LAURIER AVE @ O'CONNOR ST (0002224)	01 - Clear	01 - Daylight	01 - Traffic signal	01 - Functioning	03 - P-D only	04 - Sideswipe	01 - Dry	2	0	0	0
1/31/2017	2017	8:00	LAURIER AVE @ O'CONNOR ST (0002224)	01 - Clear	01 - Daylight	01 - Traffic signal	01 - Functioning	03 - P-D only	03 - Rear end	01 - Dry	2	0	0	0
12/10/2017	2017	17:16	LAURIER AVE W btwn BANK ST & O'CONNOR ST (_32A348)	01 - Clear	07 - Dark	10 - No control	0	06 - SMV unattended vehicle	01 - Dry	2	0	0	0	
2/5/2017	2017	8:55	LAURIER AVE @ O'CONNOR ST (0002224)	03 - Snow	01 - Daylight	01 - Traffic signal	01 - Functioning	02 - Non-fatal injury	02 - Angle	04 - Slush	2	0	0	0
2/22/2017	2017	12:26	LAURIER AVE W btwn BANK ST & O'CONNOR ST (_32A348)	01 - Clear	01 - Daylight	10 - No control	0	03 - P-D only	04 - Sideswipe	01 - Dry	2	0	0	0
3/15/2017	2017	13:00	LAURIER AVE @ O'CONNOR ST (0002224)	03 - Snow	01 - Daylight	01 - Traffic signal	01 - Functioning	03 - P-D only	03 - Rear end	03 - Loose snow	2	0	0	0
3/12/2017	2017	16:47	LAURIER AVE W btwn BANK ST & O'CONNOR ST (_32A348)	03 - Snow	01 - Daylight	10 - No control	0	03 - P-D only	02 - Angle	02 - Wet	2	0	0	0
4/4/2017	2017	9:30	LAURIER AVE W btwn BANK ST & O'CONNOR ST (_32A348)	02 - Rain	01 - Daylight	10 - No control	0	03 - P-D only	06 - SMV unattended vehicle	02 - Wet				

6/1/2017	2017	15:01	BANK ST @ LAURIER AVE (0002221)	01 - Clear	01 - Daylight	01 - Traffic signal	01 - Functioning	02 - Non-fatal injury	07 - SMV other	01 - Dry	1	0	0	1
6/9/2017	2017	14:56	BANK ST @ LAURIER AVE (0002221)	01 - Clear	01 - Daylight	01 - Traffic signal	01 - Functioning	02 - Non-fatal injury	05 - Turning movement	01 - Dry	2	0	1	0
8/3/2017	2017	16:30	BANK ST @ LAURIER AVE (0002221)	01 - Clear	01 - Daylight	01 - Traffic signal	01 - Functioning	03 - P.D. only	04 - Sideswipe	01 - Dry	2	0	0	0
9/6/2017	2017	12:53	BANK ST @ LAURIER AVE (0002221)	01 - Clear	01 - Daylight	01 - Traffic signal	01 - Functioning	02 - Non-fatal injury	04 - Sideswipe	01 - Dry	2	0	1	0
11/2/2018	2018	17:30	BANK ST @ LAURIER AVE (0002221)	02 - Rain	07 - Dark	01 - Traffic signal	01 - Functioning	02 - Non-fatal injury	07 - SMV other	02 - Wet	1	0	1	1
3/8/2018	2018	17:15	BANK ST @ LAURIER AVE (0002221)	03 - Snow	01 - Daylight	01 - Traffic signal	01 - Functioning	03 - P.D. only	03 - Rear end	02 - Wet	2	0	0	0
4/25/2018	2018	13:56	BANK ST @ LAURIER AVE (0002221)	01 - Clear	01 - Daylight	01 - Traffic signal	01 - Functioning	03 - P.D. only	04 - Sideswipe	01 - Dry	2	0	0	0
6/6/2018	2018	17:06	BANK ST @ LAURIER AVE (0002221)	01 - Clear	01 - Daylight	01 - Traffic signal	01 - Functioning	03 - P.D. only	05 - Turning movement	01 - Dry	2	0	0	0
8/13/2018	2018	10:40	BANK ST @ LAURIER AVE (0002221)	01 - Clear	01 - Daylight	01 - Traffic signal	01 - Functioning	02 - Non-fatal injury	05 - Turning movement	01 - Dry	2	0	1	0
9/20/2019	2019	14:31	BANK ST @ LAURIER AVE (0002221)	01 - Clear	01 - Daylight	01 - Traffic signal	01 - Functioning	02 - Non-fatal injury	02 - Angle	01 - Dry	2	0	0	0
12/17/2019	2019	19:08	BANK ST @ LAURIER AVE (0002221)	03 - Snow	07 - Dark	01 - Traffic signal	01 - Functioning	03 - P.D. only	03 - Rear end	04 - Slush	2	0	0	0
2/08/2019	2019	9:55	BANK ST @ LAURIER AVE (0002221)	01 - Clear	01 - Daylight	01 - Traffic signal	01 - Functioning	02 - Non-fatal injury	03 - Rear end	01 - Dry	2	0	0	0
4/19/2019	2019	1:00	BANK ST @ LAURIER AVE (0002221)	02 - Rain	07 - Dark	01 - Traffic signal	01 - Functioning	02 - Non-fatal injury	02 - Angle	02 - Wet	2	0	0	0
6/11/2019	2019	9:00	BANK ST @ LAURIER AVE (0002221)	01 - Clear	01 - Daylight	01 - Traffic signal	01 - Functioning	03 - P.D. only	04 - Sideswipe	01 - Dry	2	0	0	0
7/19/2019	2019	14:20	BANK ST @ LAURIER AVE (0002221)	01 - Clear	01 - Daylight	01 - Traffic signal	01 - Functioning	02 - Non-fatal injury	02 - Angle	01 - Dry	2	0	0	0
7/31/2019	2019	11:27	BANK ST @ LAURIER AVE (0002221)	01 - Clear	01 - Daylight	01 - Traffic signal	01 - Functioning	02 - Non-fatal injury	05 - Turning movement	01 - Dry	2	0	1	0
3/6/2020	2020	17:15	BANK ST @ LAURIER AVE (0002221)	03 - Snow	01 - Daylight	01 - Traffic signal	01 - Functioning	03 - P.D. only	04 - Sideswipe	02 - Wet	2	0	0	0
8/14/2020	2020	10:08	BANK ST @ LAURIER AVE (0002221)	01 - Clear	01 - Daylight	01 - Traffic signal	01 - Functioning	02 - Non-fatal injury	04 - Sideswipe	01 - Dry	2	0	0	0

Appendix E

TRANS Model Plots

TRANS Regional Model

Version 2.15 - Assigned June 16, 2020

AM Peak Hour Total Traffic Volume

Somerset Street W Growth Rate

2011 Model - Basecase

N/A

User Initials: TIMW

Plot Prepared: September 17, 2020

EMME Scenario: 21711



Legend

AM Peak Hour Total Traffic Volume

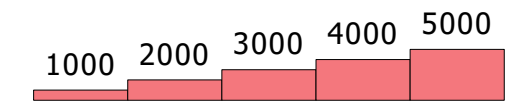

Distance (m)

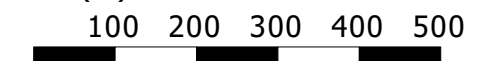

The TRANS model is continuously refined & maintained, and all information is provided in good faith. However, model outputs are provided "as is", and no warranty or guarantee is provided as to the accuracy, reliability or reasonableness of the results. In using this data, you agree to accept any and all risks arising from any incorrect, incomplete, or misleading information.

Recipients are required to use caution and professional judgement in using and interpreting model outputs. In particular, caution should be used when focusing on a geographically limited area (such as a single road or intersection), as the model is primarily designed to simulate regional-scale phenomena and has been calibrated at a regional level.

As general good practice, it is recommended that the user confirm the network coding within the area of interest, and compare base year forecasts against traffic count data to assess the extent to which the model may be over- or under-estimating the travel demand.



TRANS Regional Model

Version 2.15 - Assigned June 16, 2020

AM Peak Hour Total Traffic Volume

Somerset Street W Growth Rate

2031 Model - Basecase

N/A

User Initials: TIMW

Plot Prepared: September 17, 2020

EMME Scenario: 21711



Legend

AM Peak Hour Total Traffic Volume

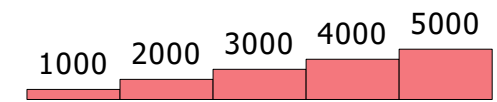

Distance (m)

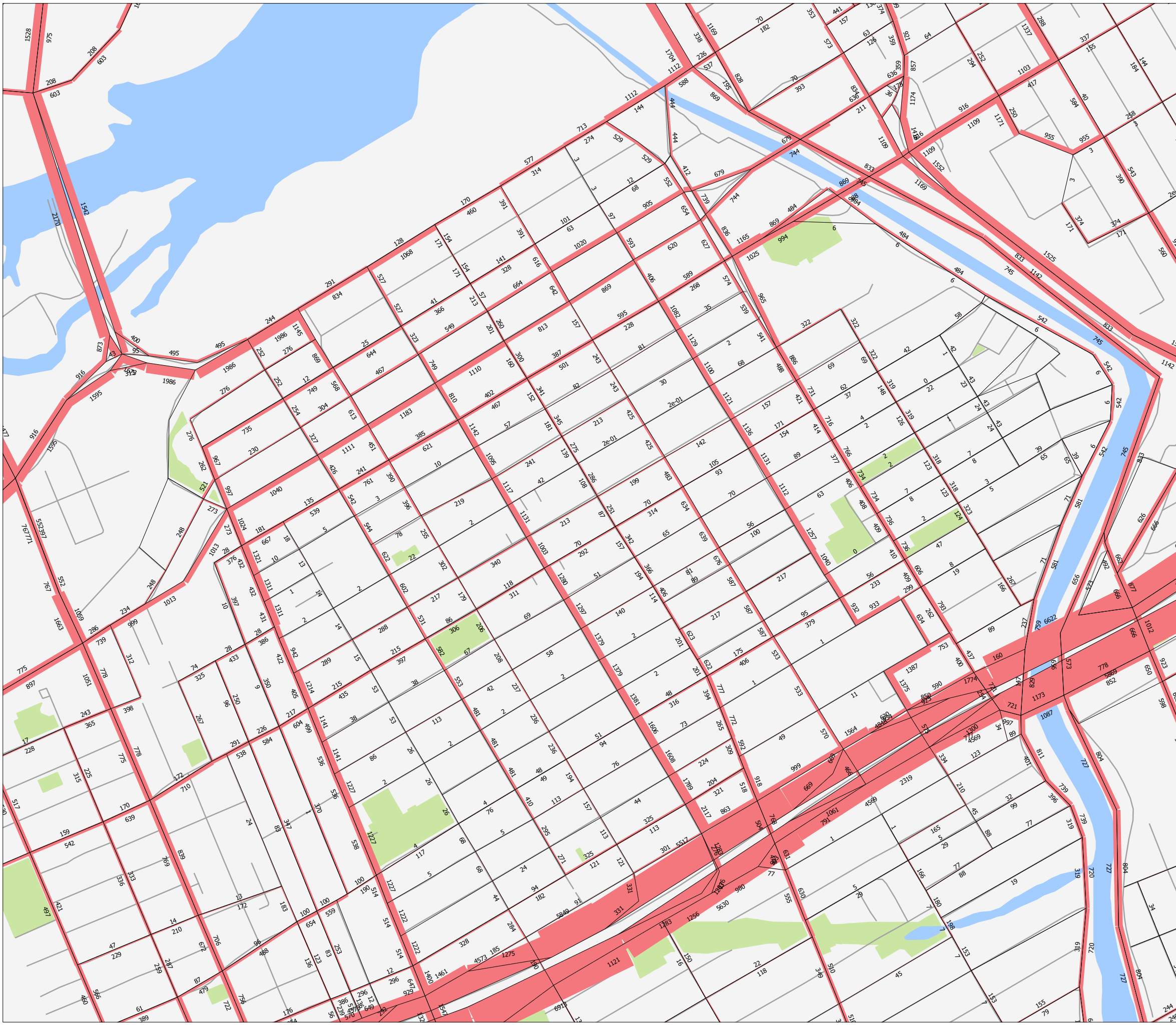
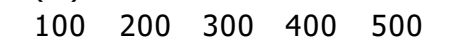

The TRANS model is continuously refined & maintained, and all information is provided in good faith. However, model outputs are provided "as is", and no warranty or guarantee is provided as to the accuracy, reliability or reasonableness of the results. In using this data, you agree to accept any and all risks arising from any incorrect, incomplete, or misleading information.

Recipients are required to use caution and professional judgement in using and interpreting model outputs. In particular, caution should be used when focusing on a geographically limited area (such as a single road or intersection), as the model is primarily designed to simulate regional-scale phenomena and has been calibrated at a regional level.

As a general good practice, it is recommended that the user confirm the network coding within the area of interest, and compare base year forecasts against traffic count data to assess the extent to which the model may be over- or under-estimating the travel demand.

Appendix F

Intersection Traffic Growth Rate between 2000 and 2016

INTERSECTION TRAFFIC GROWTH RATE, AM PEAK PERIOD

Total Vehicular Volume Entering the Intersection, 2000 to 2016

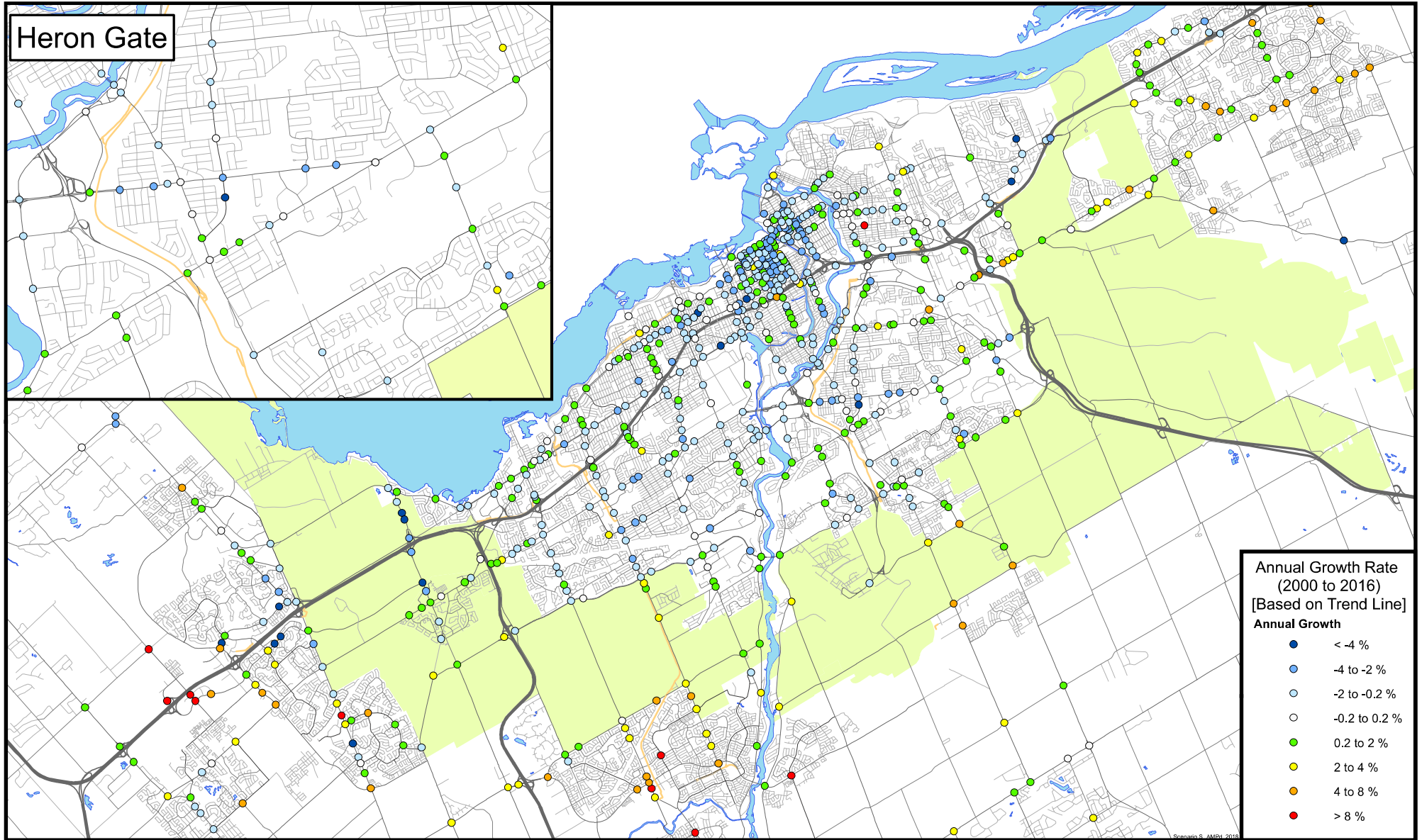

Appendix G

Background Development Volumes

Table 16: Trip Assignment

To/From	Inbound Via	Outbound Via
North	10% Elgin (N)	10% Metcalfe (N)
South	15% Metcalfe (S) 25% Laurier (W)	20% O'Connor (S) 10% Laurier (E) 10% Nepean (S)
East	10% Laurier (E)	10% Laurier (E)
West	40% Laurier (W)	40% Laurier (W)
Total	100%	100%

Figure 12: New Site Generation Auto Volumes

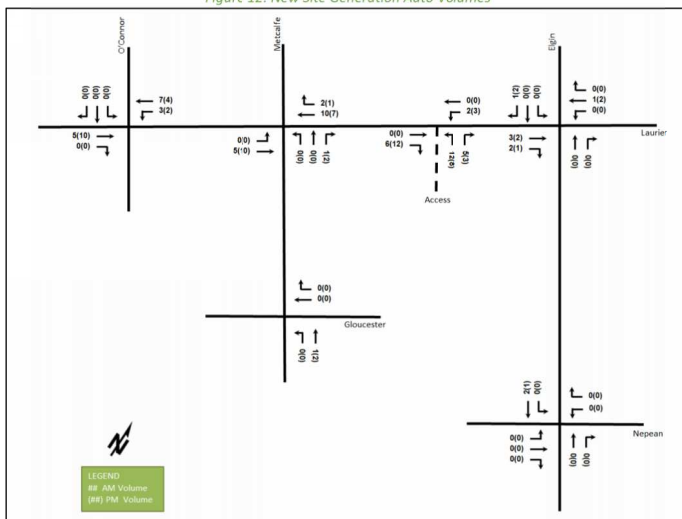
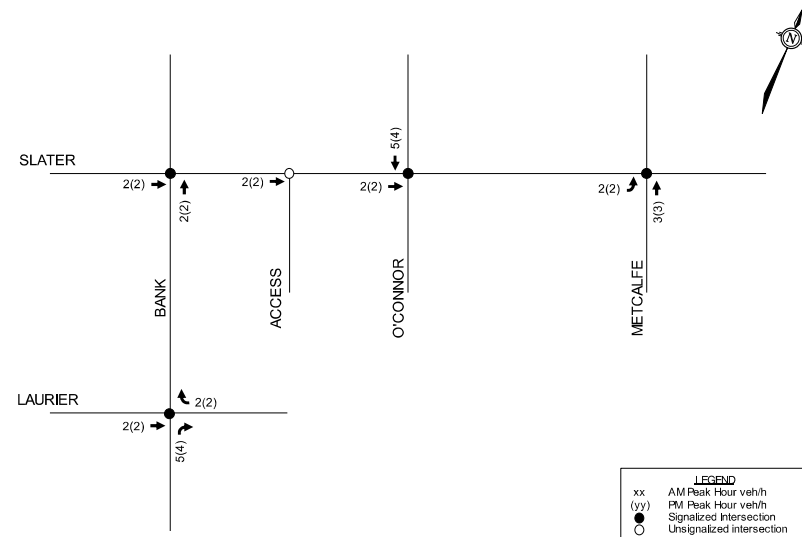

Figure 6: Site Generated Traffic



Appendix H

Synchro Intersection Worksheets – 2028 Future Background Conditions

Lanes, Volumes, Timings

2028 Future Background

1: Bank Street & Slater Street /Slater Street

AM Peak Hour



Lane Group	EBL	EBT	EBR	WBL	WBT	WBR	NBL	NBT	NBR	SBL	SBT	SBR
Lane Configurations		↕↕	↕					↕			↕	
Traffic Volume (vph)	22	855	90	0	0	0	0	207	23	14	230	0
Future Volume (vph)	22	855	90	0	0	0	0	207	23	14	230	0
Satd. Flow (prot)	0	2785	1335	0	0	0	0	1410	0	0	1566	0
Fit Permitted		0.999									0.979	
Satd. Flow (perm)	0	2772	876	0	0	0	0	1410	0	0	1518	0
Satd. Flow (RTOR)			65					9				
Lane Group Flow (vph)	0	877	90	0	0	0	0	230	0	0	244	0
Turn Type	pm+pt	NA	Perm					NA	Perm	NA		
Protected Phases	5	2						4			8	
Permitted Phases	2		2							8		
Detector Phase	5	2	2					4		8	8	
Switch Phase												
Minimum Initial (s)	5.0	10.0	10.0					10.0	10.0	10.0		
Minimum Split (s)	10.0	24.0	24.0					35.0	35.0	35.0		
Total Split (s)	12.0	40.0	40.0					35.0	35.0	35.0		
Total Split (%)	16.0%	53.3%	53.3%					46.7%	46.7%	46.7%		
Yellow Time (s)	3.3	3.3	3.3					3.3	3.3	3.3		
All-Red Time (s)	1.7	1.7	1.7					2.2	2.2	2.2		
Lost Time Adjust (s)		0.0	0.0					0.0	0.0	0.0		
Total Lost Time (s)		5.0	5.0					5.5		5.5		
Lead/Lag	Lead										Lag	
Lead-Lag Optimize?	Yes										Yes	
Recall Mode	Max	C-Max	C-Max					Max	Max	Max		
Act Effct Green (s)		35.0	35.0					29.5		29.5		
Actuated g/C Ratio		0.47	0.47					0.39		0.39		
v/c Ratio		0.68	0.20					0.41		0.41		
Control Delay		18.9	6.2					12.0		19.1		
Queue Delay		0.0	0.0					0.0		0.0		
Total Delay		18.9	6.2					12.0		19.1		
LOS		B	A					B		B		
Approach Delay		17.7						12.0		19.1		
Approach LOS		B						B		B		
Queue Length 50th (m)		48.3	1.9					8.5		24.3		
Queue Length 95th (m)		68.1	9.3					24.4		42.2		
Internal Link Dist (m)		64.9			157.3			81.5		43.1		
Turn Bay Length (m)			65.0									
Base Capacity (vph)		1294	443					560		597		
Starvation Cap Reductn		0	0					0		0		
Spillback Cap Reductn		0	0					0		0		
Storage Cap Reductn		0	0					0		0		
Reduced v/c Ratio		0.68	0.20					0.41		0.41		

Intersection Summary

Cycle Length: 75
 Actuated Cycle Length: 75
 Offset: 48 (64%), Referenced to phase 2:EBTL and 6:Hold, Start of Green
 Natural Cycle: 60
 Control Type: Actuated-Coordinated

Lanes, Volumes, Timings

2028 Future Background

1: Bank Street & Slater Street /Slater Street

AM Peak Hour

Lane Group	Ø6
Lane Configurations	
Traffic Volume (vph)	
Future Volume (vph)	
Satd. Flow (prot)	
Fit Permitted	
Satd. Flow (perm)	
Satd. Flow (RTOR)	
Lane Group Flow (vph)	
Turn Type	
Protected Phases	6
Permitted Phases	
Detector Phase	
Switch Phase	
Minimum Initial (s)	1.0
Minimum Split (s)	3.0
Total Split (s)	28.0
Total Split (%)	37%
Yellow Time (s)	2.0
All-Red Time (s)	0.0
Lost Time Adjust (s)	
Total Lost Time (s)	
Lead/Lag	Lag
Lead-Lag Optimize?	Yes
Recall Mode	C-Max
Act Effct Green (s)	
Actuated g/C Ratio	
v/c Ratio	
Control Delay	
Queue Delay	
Total Delay	
LOS	
Approach Delay	
Approach LOS	
Queue Length 50th (m)	
Queue Length 95th (m)	
Internal Link Dist (m)	
Turn Bay Length (m)	
Base Capacity (vph)	
Starvation Cap Reductn	
Spillback Cap Reductn	
Storage Cap Reductn	
Reduced v/c Ratio	

Intersection Summary

Lanes, Volumes, Timings
1: Bank Street & Slater Street /Slater Street

2028 Future Background
AM Peak Hour

Maximum v/c Ratio: 0.68	Intersection LOS: B
Intersection Signal Delay: 17.0	ICU Level of Service C
Intersection Capacity Utilization 68.2%	
Analysis Period (min) 15	



Lanes, Volumes, Timings
2: O'Connor Street & Slater Street

2028 Future Background
AM Peak Hour

Lane Group	EBL	EBT	EBR	WBL	WBT	WBR	NBL	NBT	NBR	SBL	SBT	SBR
Lane Configurations		↑↑	↑							↑	↑↑↑	
Traffic Volume (vph)	0	671	55	0	0	0	0	0	0	119	240	0
Future Volume (vph)	0	671	55	0	0	0	0	0	0	119	240	0
Satd. Flow (prot)	0	2767	1297	0	0	0	0	0	0	1463	4165	0
Fit Permitted										0.950		
Satd. Flow (perm)	0	2767	1035	0	0	0	0	0	0	941	4165	0
Satd. Flow (RTOR)										57		
Lane Group Flow (vph)	0	671	55	0	0	0	0	0	0	119	240	0
Turn Type		NA	Perm							Perm	NA	
Protected Phases		4									6	
Permitted Phases			4									6
Detector Phase		4	4								6	6
Switch Phase												
Minimum Initial (s)		10.0	10.0							10.0	10.0	
Minimum Split (s)		30.5	30.5							22.5	22.5	
Total Split (s)		41.0	41.0							34.0	34.0	
Total Split (%)		54.7%	54.7%							45.3%	45.3%	
Yellow Time (s)		3.3	3.3							3.3	3.3	
All-Red Time (s)		2.2	2.2							2.2	2.2	
Lost Time Adjust (s)		0.0	0.0							0.0	0.0	
Total Lost Time (s)		5.5	5.5							5.5	5.5	
Lead/Lag												
Lead-Lag Optimize?												
Recall Mode		C-Max	C-Max							Max	Max	
Act Effct Green (s)		35.5	35.5							28.5	28.5	
Actuated g/C Ratio		0.47	0.47							0.38	0.38	
v/c Ratio		0.51	0.11							0.30	0.15	
Control Delay		2.4	1.7							11.6	15.6	
Queue Delay		0.0	0.0							0.0	0.0	
Total Delay		2.4	1.7							11.6	15.6	
LOS		A	A							B	B	
Approach Delay		2.4									14.3	
Approach LOS		A									B	
Queue Length 50th (m)		2.6	0.4							5.7	7.9	
Queue Length 95th (m)		3.5	m0.6							17.1	12.9	
Internal Link Dist (m)		157.3				58.3		84.2			37.7	
Turn Bay Length (m)			30.0									
Base Capacity (vph)		1309	489							392	1582	
Starvation Cap Reductn		0	0							0	0	
Spillback Cap Reductn		0	0							0	0	
Storage Cap Reductn		0	0							0	0	
Reduced v/c Ratio		0.51	0.11							0.30	0.15	
Intersection Summary												
Cycle Length: 75												
Actuated Cycle Length: 75												
Offset: 48 (64%), Referenced to phase 4:EBT, Start of Green												
Natural Cycle: 55												
Control Type: Actuated-Coordinated												

Lanes, Volumes, Timings
2: O'Connor Street & Slater Street

2028 Future Background
AM Peak Hour

Maximum v/c Ratio: 0.51	Intersection LOS: A
Intersection Signal Delay: 6.3	ICU Level of Service A
Intersection Capacity Utilization 45.1%	
Analysis Period (min) 15	

m Volume for 95th percentile queue is metered by upstream signal.

Splits and Phases: 2: O'Connor Street & Slater Street

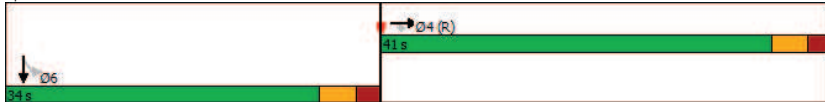

Lanes, Volumes, Timings
3: Bank Street & Laurier Avenue West

2028 Future Background
AM Peak Hour

Lane Group	EBL	EBT	EBR	WBL	WBT	WBR	NBL	NBT	NBR	SBL	SBT	SBR
Lane Configurations		↕	↕		↕			↕	↕		↕	↕
Traffic Volume (vph)	2	306	51	0	242	41	1	183	140	12	253	58
Future Volume (vph)	2	306	51	0	242	41	1	183	140	12	253	58
Satd. Flow (prot)	0	1566	1335	0	1348	0	0	1382	1335	0	1484	1335
Fit Permitted		0.998						0.999			0.987	
Satd. Flow (perm)	0	1560	498	0	1348	0	0	1377	479	0	1435	435
Satd. Flow (RTOR)												
Lane Group Flow (vph)	0	308	51	0	283	0	0	184	140	0	265	58
Turn Type	Perm	NA	Perm	NA	Perm	NA	Perm	NA	Perm	Perm	NA	Perm
Protected Phases		2			6			8			4	
Permitted Phases	2		2				8		8	4		4
Detector Phase	2	2	2		6		8	8	8	4	4	4
Switch Phase												
Minimum Initial (s)	10.0	10.0	10.0		10.0		10.0	10.0	10.0	10.0	10.0	10.0
Minimum Split (s)	23.9	23.9	23.9		23.9		23.6	23.6	23.6	23.6	23.6	23.6
Total Split (s)	27.0	27.0	27.0		27.0		38.0	38.0	38.0	38.0	38.0	38.0
Total Split (%)	36.0%	36.0%	36.0%		36.0%		50.7%	50.7%	50.7%	50.7%	50.7%	50.7%
Yellow Time (s)	3.3	3.3	3.3		3.3		3.3	3.3	3.3	3.3	3.3	3.3
All-Red Time (s)	2.6	2.6	2.6		2.6		2.3	2.3	2.3	2.3	2.3	2.3
Lost Time Adjust (s)		0.0	0.0		0.0		0.0	0.0	0.0	0.0	0.0	0.0
Total Lost Time (s)		5.9	5.9		5.9		5.6	5.6	5.6	5.6	5.6	5.6
Lead/Lag	Lag	Lag	Lag		Lag		Lag	Lag	Lag	Lag	Lag	Lag
Lead-Lag Optimize?	Yes	Yes	Yes		Yes		Yes	Yes	Yes	Yes	Yes	Yes
Recall Mode	C-Max	C-Max	C-Max		C-Max		Max	Max	Max	Max	Max	Max
Act Effct Green (s)	26.1	26.1	26.1		26.1		37.4	37.4	37.4	37.4	37.4	37.4
Actuated g/C Ratio	0.35	0.35			0.35		0.50	0.50		0.50	0.50	0.50
v/c Ratio	0.57	0.29			0.60		0.27	0.59		0.37	0.27	
Control Delay	24.9	23.5			41.2		12.2	26.0		8.1	9.7	
Queue Delay	0.0	0.0			0.0		0.0	0.0		0.0	0.0	
Total Delay	24.9	23.5			41.2		12.2	26.0		8.1	9.7	
LOS	C	C			D		B	C		A	A	
Approach Delay	24.7				41.2		18.2			8.4		
Approach LOS	C				D		B			A		
Queue Length 50th (m)	34.8	5.2			40.3		14.2	13.2		10.2	2.2	
Queue Length 95th (m)	58.5	14.2			63.7		26.1	#38.6		18.6	6.0	
Internal Link Dist (m)	75.4				68.9		45.4			81.5		
Turn Bay Length (m)			45.0									10.0
Base Capacity (vph)		542	173		469		686	238		715	216	
Starvation Cap Reductn	0	0			0		0	0		0	0	
Spillback Cap Reductn	0	0			0		0	0		0	0	
Storage Cap Reductn	0	0			0		0	0		0	0	
Reduced v/c Ratio		0.57	0.29		0.60		0.27	0.59		0.37	0.27	

Intersection Summary												
Cycle Length: 75												
Actuated Cycle Length: 75												
Offset: 40 (53%), Referenced to phase 2:EBTL and 6:WBT, Start of Green												
Natural Cycle: 60												
Control Type: Actuated-Coordinated												

Lanes, Volumes, Timings
3: Bank Street & Laurier Avenue West

2028 Future Background
AM Peak Hour

Lane Group	Ø1	Ø3	Ø5	Ø7
Lane Configurations				
Traffic Volume (vph)				
Future Volume (vph)				
Satd. Flow (prot)				
Fit Permitted				
Satd. Flow (perm)				
Satd. Flow (RTOR)				
Lane Group Flow (vph)				
Turn Type				
Protected Phases	1	3	5	7
Permitted Phases				
Detector Phase				
Switch Phase				
Minimum Initial (s)	1.0	1.0	1.0	1.0
Minimum Split (s)	3.0	3.0	3.0	3.0
Total Split (s)	5.0	5.0	5.0	5.0
Total Split (%)	7%	7%	7%	7%
Yellow Time (s)	2.0	2.0	2.0	2.0
All-Red Time (s)	0.0	0.0	0.0	0.0
Lost Time Adjust (s)				
Total Lost Time (s)				
Lead/Lag	Lead	Lead	Lead	Lead
Lead-Lag Optimize?	Yes	Yes	Yes	Yes
Recall Mode	None	None	None	None
Act Effct Green (s)				
Actuated g/C Ratio				
v/c Ratio				
Control Delay				
Queue Delay				
Total Delay				
LOS				
Approach Delay				
Approach LOS				
Queue Length 50th (m)				
Queue Length 95th (m)				
Internal Link Dist (m)				
Turn Bay Length (m)				
Base Capacity (vph)				
Starvation Cap Reductn				
Spillback Cap Reductn				
Storage Cap Reductn				
Reduced v/c Ratio				
Intersection Summary				

Lanes, Volumes, Timings
3: Bank Street & Laurier Avenue West

2028 Future Background
AM Peak Hour

Maximum v/c Ratio: 0.60	
Intersection Signal Delay: 22.6	Intersection LOS: C
Intersection Capacity Utilization 68.5%	ICU Level of Service C
Analysis Period (min) 15	
# 95th percentile volume exceeds capacity, queue may be longer.	
Queue shown is maximum after two cycles.	

Splits and Phases: 3: Bank Street & Laurier Avenue West

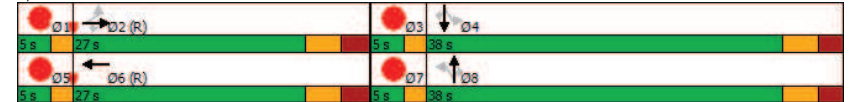

Lanes, Volumes, Timings
4: O'Connor Street & Laurier Avenue West

2028 Future Background
AM Peak Hour

Lane Group	EBL	EBT	EBR	WBL	WBT	WBR	NBL	NBT	NBR	SBL	SBT	SBR
Lane Configurations		↔	↔	↔	↔						↔↔↔	
Traffic Volume (vph)	0	217	149	146	305	0	0	0	0	28	229	26
Future Volume (vph)	0	217	149	146	305	0	0	0	0	28	229	26
Satd. Flow (prot)	0	1262	0	1492	1511	0	0	0	0	0	3858	0
Fit Permitted				0.353							0.995	
Satd. Flow (perm)	0	1262	0	554	1511	0	0	0	0	0	3631	0
Satd. Flow (RTOR)												
Lane Group Flow (vph)	0	366	0	146	305	0	0	0	0	0	283	0
Turn Type		NA		pm+pt	NA					Perm	NA	
Protected Phases		2		9	6							4
Permitted Phases				6							4	
Detector Phase		2		9	6						4	4
Switch Phase												
Minimum Initial (s)		10.0		5.0	10.0					10.0	10.0	
Minimum Split (s)		16.9		10.8	16.9					16.7	16.7	
Total Split (s)		29.0		11.0	45.0					25.0	25.0	
Total Split (%)		38.7%		14.7%	60.0%					33.3%	33.3%	
Yellow Time (s)		3.3		3.3	3.3					3.3	3.3	
All-Red Time (s)		2.6		2.5	2.6					2.4	2.4	
Lost Time Adjust (s)		0.0		0.0	0.0						0.0	
Total Lost Time (s)		5.9		5.8	5.9						5.7	
Lead/Lag				Lead						Lag	Lag	
Lead-Lag Optimize?				Yes						Yes	Yes	
Recall Mode		C-Max		Max	C-Max					Max	Max	
Act Effct Green (s)		28.1		39.2	39.1						24.3	
Actuated g/C Ratio		0.37		0.52	0.52						0.32	
v/c Ratio		0.78		0.41	0.39						0.24	
Control Delay		30.9		13.4	12.6						9.4	
Queue Delay		0.0		0.0	0.0						0.0	
Total Delay		30.9		13.4	12.6						9.4	
LOS		C		B	B						A	
Approach Delay		30.9			12.9						9.4	
Approach LOS		C			B						A	
Queue Length 50th (m)		50.2		10.2	24.1						4.5	
Queue Length 95th (m)		#88.4		19.5	41.1						6.9	
Internal Link Dist (m)		64.2			50.7			45.5			84.2	
Turn Bay Length (m)				15.0								
Base Capacity (vph)		472		354	787						1176	
Starvation Cap Reductn		0		0	0						0	
Spillback Cap Reductn		0		0	0						0	
Storage Cap Reductn		0		0	0						0	
Reduced v/c Ratio		0.78		0.41	0.39						0.24	

Intersection Summary	
Cycle Length: 75	
Actuated Cycle Length: 75	
Offset: 63 (84%), Referenced to phase 2:EBT and 6:WBTL, Start of Green	
Natural Cycle: 65	
Control Type: Actuated-Coordinated	

Lanes, Volumes, Timings
4: O'Connor Street & Laurier Avenue West

2028 Future Background
AM Peak Hour

Lane Group	Ø1	Ø3
Lane Configurations		
Traffic Volume (vph)		
Future Volume (vph)		
Satd. Flow (prot)		
Fit Permitted		
Satd. Flow (perm)		
Satd. Flow (RTOR)		
Lane Group Flow (vph)		
Turn Type		
Protected Phases	1	3
Permitted Phases		
Detector Phase		
Switch Phase		
Minimum Initial (s)	1.0	1.0
Minimum Split (s)	5.0	5.0
Total Split (s)	5.0	5.0
Total Split (%)	7%	7%
Yellow Time (s)	2.0	2.0
All-Red Time (s)	0.0	0.0
Lost Time Adjust (s)		
Total Lost Time (s)		
Lead/Lag	Lag	Lead
Lead-Lag Optimize?	Yes	Yes
Recall Mode	None	None
Act Effct Green (s)		
Actuated g/C Ratio		
v/c Ratio		
Control Delay		
Queue Delay		
Total Delay		
LOS		
Approach Delay		
Approach LOS		
Queue Length 50th (m)		
Queue Length 95th (m)		
Internal Link Dist (m)		
Turn Bay Length (m)		
Base Capacity (vph)		
Starvation Cap Reductn		
Spillback Cap Reductn		
Storage Cap Reductn		
Reduced v/c Ratio		

Intersection Summary	
Cycle Length: 75	
Actuated Cycle Length: 75	
Offset: 63 (84%), Referenced to phase 2:EBT and 6:WBTL, Start of Green	
Natural Cycle: 65	
Control Type: Actuated-Coordinated	

Lanes, Volumes, Timings
4: O'Connor Street & Laurier Avenue West

2028 Future Background
AM Peak Hour

Maximum v/c Ratio: 0.78	Intersection LOS: B
Intersection Signal Delay: 18.0	ICU Level of Service B
Intersection Capacity Utilization 63.2%	
Analysis Period (min) 15	
# 95th percentile volume exceeds capacity, queue may be longer.	
Queue shown is maximum after two cycles.	

Splits and Phases: 4: O'Connor Street & Laurier Avenue West

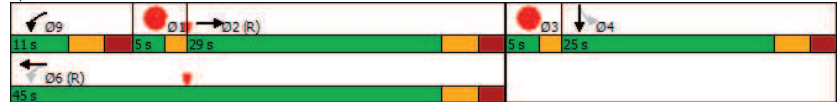

HCM 2010 TWSC
5: Laurier Avenue West & Site Access #1

2028 Future Background
AM Peak Hour

Intersection						
Int Delay, s/veh	1.2					
Movement	EBL	EBT	WBT	WBR	SBL	SBR
Lane Configurations		↕	↕		↕	↕
Traffic Vol, veh/h	104	458	341	63	2	3
Future Vol, veh/h	104	458	341	63	2	3
Conflicting Peds, #/hr	198	0	0	198	10	10
Sign Control	Free	Free	Free	Free	Stop	Stop
RT Channelized	-	None	-	None	-	None
Storage Length	-	-	-	-	0	-
Veh in Median Storage, #	-	0	0	-	0	-
Grade, %	-	0	0	-	0	-
Peak Hour Factor	100	100	100	100	100	100
Heavy Vehicles, %	2	2	2	2	2	2
Mvmt Flow	104	458	341	63	2	3
Major/Minor	Major1	Major2	Minor2			
Conflicting Flow All	602	0	0	1247	581	
Stage 1	-	-	-	571	-	
Stage 2	-	-	-	676	-	
Critical Hdwy	4.12	-	-	6.42	6.22	
Critical Hdwy Stg 1	-	-	-	5.42	-	
Critical Hdwy Stg 2	-	-	-	5.42	-	
Follow-up Hdwy	2,218	-	-	3,518	3,318	
Pot Cap-1 Maneuver	975	-	-	192	514	
Stage 1	-	-	-	565	-	
Stage 2	-	-	-	505	-	
Platoon blocked, %	-	-	-	-	-	
Mov Cap-1 Maneuver	795	-	-	105	415	
Mov Cap-2 Maneuver	-	-	-	105	-	
Stage 1	-	-	-	380	-	
Stage 2	-	-	-	412	-	
Approach	EB	WB	SB			
HCM Control Delay, s	1.9	0	24.5			
HCM LOS			C			
Minor Lane/Major Mvmt	EBL	EBT	WBT	WBR	SBLn1	
Capacity (veh/h)	795	-	-	-	190	
HCM Lane V/C Ratio	0.131	-	-	-	0.026	
HCM Control Delay (s)	10.2	0	-	-	24.5	
HCM Lane LOS	B	A	-	-	C	
HCM 95th %tile Q(veh)	0.4	-	-	-	0.1	

Lanes, Volumes, Timings

2028 Future Background

1: Bank Street & Slater Street /Slater Street

PM Peak Hour



Lane Group	EBL	EBT	EBR	WBL	WBT	WBR	NBL	NBT	NBR	SBL	SBT	SBR
Lane Configurations		↕↕	↕					↕			↕	
Traffic Volume (vph)	25	817	154	0	0	0	0	244	19	13	233	0
Future Volume (vph)	25	817	154	0	0	0	0	244	19	13	233	0
Satd. Flow (prot)	0	2908	1335	0	0	0	0	1448	0	0	1461	0
Fit Permitted		0.999									0.979	
Satd. Flow (perm)	0	2887	940	0	0	0	0	1448	0	0	1417	0
Satd. Flow (RTOR)			45					6				
Lane Group Flow (vph)	0	842	154	0	0	0	0	263	0	0	246	0
Turn Type	pm+pt	NA	Perm					NA	Perm	NA		
Protected Phases	5	2						4			8	
Permitted Phases	2		2							8		
Detector Phase	5	2	2					4		8	8	
Switch Phase												
Minimum Initial (s)	5.0	10.0	10.0					10.0	10.0	10.0		
Minimum Split (s)	10.0	24.0	24.0					35.0	35.0	35.0		
Total Split (s)	12.0	40.0	40.0					35.0	35.0	35.0		
Total Split (%)	16.0%	53.3%	53.3%					46.7%	46.7%	46.7%		
Yellow Time (s)	3.3	3.3	3.3					3.3	3.3	3.3		
All-Red Time (s)	1.7	1.7	1.7					2.2	2.2	2.2		
Lost Time Adjust (s)		0.0	0.0					0.0	0.0	0.0		
Total Lost Time (s)		5.0	5.0					5.5		5.5		
Lead/Lag	Lead										Lag	
Lead-Lag Optimize?	Yes										Yes	
Recall Mode	Max	C-Max	C-Max					Max	Max	Max		
Act Effct Green (s)		35.0	35.0					29.5			29.5	
Actuated g/C Ratio		0.47	0.47					0.39			0.39	
v/c Ratio		0.62	0.33					0.46			0.44	
Control Delay		17.6	11.2					13.6			19.9	
Queue Delay		0.0	0.0					0.0			0.0	
Total Delay		17.6	11.2					13.6			19.9	
LOS		B	B					B			B	
Approach Delay		16.6						13.6			19.9	
Approach LOS		B						B			B	
Queue Length 50th (m)		44.8	8.9					13.6			24.9	
Queue Length 95th (m)		62.7	21.4					m20.9			43.8	
Internal Link Dist (m)		64.9				157.3		81.5			43.1	
Turn Bay Length (m)			65.0									
Base Capacity (vph)		1349	462					573			557	
Starvation Cap Reductn		0	0					0			0	
Spillback Cap Reductn		0	0					0			0	
Storage Cap Reductn		0	0					0			0	
Reduced v/c Ratio		0.62	0.33					0.46			0.44	

Intersection Summary

Cycle Length: 75

Actuated Cycle Length: 75

Offset: 20 (27%), Referenced to phase 2:EBTL and 6:Hold, Start of Green

Natural Cycle: 60

Control Type: Actuated-Coordinated

Lanes, Volumes, Timings

2028 Future Background

1: Bank Street & Slater Street /Slater Street

PM Peak Hour

Lane Group	Ø6
Lane Configurations	
Traffic Volume (vph)	
Future Volume (vph)	
Satd. Flow (prot)	
Fit Permitted	
Satd. Flow (perm)	
Satd. Flow (RTOR)	
Lane Group Flow (vph)	
Turn Type	
Protected Phases	6
Permitted Phases	
Detector Phase	
Switch Phase	
Minimum Initial (s)	1.0
Minimum Split (s)	3.0
Total Split (s)	28.0
Total Split (%)	37%
Yellow Time (s)	2.0
All-Red Time (s)	0.0
Lost Time Adjust (s)	
Total Lost Time (s)	
Lead/Lag	Lag
Lead-Lag Optimize?	Yes
Recall Mode	C-Max
Act Effct Green (s)	
Actuated g/C Ratio	
v/c Ratio	
Control Delay	
Queue Delay	
Total Delay	
LOS	
Approach Delay	
Approach LOS	
Queue Length 50th (m)	
Queue Length 95th (m)	
Internal Link Dist (m)	
Turn Bay Length (m)	
Base Capacity (vph)	
Starvation Cap Reductn	
Spillback Cap Reductn	
Storage Cap Reductn	
Reduced v/c Ratio	

Intersection Summary

Lanes, Volumes, Timings
1: Bank Street & Slater Street /Slater Street

2028 Future Background
PM Peak Hour

Maximum v/c Ratio: 0.62	Intersection LOS: B
Intersection Signal Delay: 16.6	ICU Level of Service C
Intersection Capacity Utilization 66.3%	
Analysis Period (min) 15	

m Volume for 95th percentile queue is metered by upstream signal.

Splits and Phases: 1: Bank Street & Slater Street /Slater Street

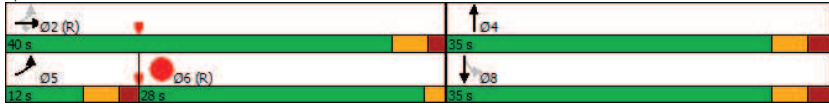

Lanes, Volumes, Timings
2: O'Connor Street & Slater Street

2028 Future Background
PM Peak Hour

Lane Group	EBL	EBT	EBR	WBL	WBT	WBR	NBL	NBT	NBR	SBL	SBT	SBR
Lane Configurations		↑↑	↑							↑	↑↑↑	
Traffic Volume (vph)	0	787	61	0	0	0	0	0	0	105	360	0
Future Volume (vph)	0	787	61	0	0	0	0	0	0	105	360	0
Satd. Flow (prot)	0	2899	1322	0	0	0	0	0	0	1436	4288	0
Fit Permitted										0.950		
Satd. Flow (perm)	0	2899	1060	0	0	0	0	0	0	975	4288	0
Satd. Flow (RTOR)										60		
Lane Group Flow (vph)	0	787	61	0	0	0	0	0	0	105	360	0
Turn Type		NA	Perm							Perm	NA	
Protected Phases		4									6	
Permitted Phases			4								6	
Detector Phase		4	4							6	6	
Switch Phase												
Minimum Initial (s)		10.0	10.0							10.0	10.0	
Minimum Split (s)		30.5	30.5							22.5	22.5	
Total Split (s)		45.0	45.0							30.0	30.0	
Total Split (%)		60.0%	60.0%							40.0%	40.0%	
Yellow Time (s)		3.3	3.3							3.3	3.3	
All-Red Time (s)		2.2	2.2							2.2	2.2	
Lost Time Adjust (s)		0.0	0.0							0.0	0.0	
Total Lost Time (s)		5.5	5.5							5.5	5.5	
Lead/Lag												
Lead-Lag Optimize?												
Recall Mode		C-Max	C-Max							Max	Max	
Act Effct Green (s)		39.5	39.5							24.5	24.5	
Actuated g/C Ratio		0.53	0.53							0.33	0.33	
v/c Ratio		0.52	0.11							0.29	0.26	
Control Delay		3.7	2.9							12.0	19.2	
Queue Delay		0.0	0.0							0.0	0.0	
Total Delay		3.7	2.9							12.0	19.2	
LOS		A	A							B	B	
Approach Delay		3.6									17.6	
Approach LOS		A									B	
Queue Length 50th (m)		6.1	0.9							4.4	13.5	
Queue Length 95th (m)		7.7	m1.5							15.6	20.2	
Internal Link Dist (m)		157.3				58.3		84.2			37.7	
Turn Bay Length (m)			30.0									
Base Capacity (vph)		1526	558							358	1400	
Starvation Cap Reductn		0	0							0	0	
Spillback Cap Reductn		0	0							0	0	
Storage Cap Reductn		0	0							0	0	
Reduced v/c Ratio		0.52	0.11							0.29	0.26	

Intersection Summary

Cycle Length: 75
Actuated Cycle Length: 75
Offset: 12 (16%), Referenced to phase 4:EBT, Start of Green
Natural Cycle: 55
Control Type: Actuated-Coordinated

Lanes, Volumes, Timings
2: O'Connor Street & Slater Street

2028 Future Background
PM Peak Hour

Maximum v/c Ratio: 0.52	Intersection LOS: A
Intersection Signal Delay: 8.6	ICU Level of Service A
Intersection Capacity Utilization 48.8%	
Analysis Period (min) 15	

m Volume for 95th percentile queue is metered by upstream signal.

Splits and Phases: 2: O'Connor Street & Slater Street

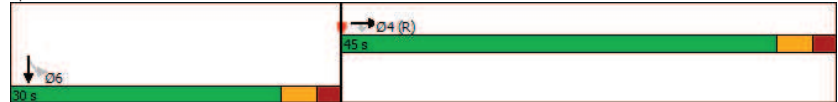

Lanes, Volumes, Timings
3: Bank Street & Laurier Avenue West

2028 Future Background
PM Peak Hour

Lane Group	EBL	EBT	EBR	WBL	WBT	WBR	NBL	NBT	NBR	SBL	SBT	SBR
Lane Configurations		↖ ↗	↖ ↗		↖ ↗			↖ ↗	↖ ↗		↖ ↗	↖ ↗
Traffic Volume (vph)	0	240	80	2	285	81	1	197	81	18	300	76
Future Volume (vph)	0	240	80	2	285	81	1	197	81	18	300	76
Satd. Flow (prot)	0	1571	1335	0	1325	0	0	1491	1335	0	1537	1335
Fit Permitted					0.999			0.999			0.980	
Satd. Flow (perm)	0	1571	471	0	1321	0	0	1486	223	0	1458	261
Satd. Flow (RTOR)												
Lane Group Flow (vph)	0	240	80	0	368	0	0	198	81	0	318	76
Turn Type		NA	Perm	Perm	NA		Perm	NA	Perm	Perm	NA	Perm
Protected Phases		2			6			8			4	
Permitted Phases	2		2	6			8		8	4		4
Detector Phase	2	2	2	6	6		8	8	8	4	4	4
Switch Phase												
Minimum Initial (s)	10.0	10.0	10.0	10.0	10.0		10.0	10.0	10.0	10.0	10.0	10.0
Minimum Split (s)	23.9	23.9	23.9	23.9	23.9		23.6	23.6	23.6	23.6	23.6	23.6
Total Split (s)	30.0	30.0	30.0	30.0	30.0		35.0	35.0	35.0	35.0	35.0	35.0
Total Split (%)	40.0%	40.0%	40.0%	40.0%	40.0%		46.7%	46.7%	46.7%	46.7%	46.7%	46.7%
Yellow Time (s)	3.3	3.3	3.3	3.3	3.3		3.3	3.3	3.3	3.3	3.3	3.3
All-Red Time (s)	2.6	2.6	2.6	2.6	2.6		2.3	2.3	2.3	2.3	2.3	2.3
Lost Time Adjust (s)		0.0	0.0		0.0			0.0	0.0		0.0	0.0
Total Lost Time (s)		5.9	5.9		5.9			5.6	5.6		5.6	5.6
Lead/Lag	Lag	Lag	Lag	Lag	Lag		Lag	Lag	Lag	Lag	Lag	Lag
Lead-Lag Optimize?	Yes	Yes	Yes	Yes	Yes		Yes	Yes	Yes	Yes	Yes	Yes
Recall Mode	C-Max	C-Max	C-Max	C-Max	C-Max		Max	Max	Max	Max	Max	Max
Act Effct Green (s)	29.1	29.1	29.1	29.1	29.1		34.4	34.4	34.4	34.4	34.4	34.4
Actuated g/C Ratio	0.39	0.39		0.39			0.46	0.46		0.46	0.46	0.46
v/c Ratio	0.39	0.44		0.72			0.29	0.79		0.48	0.64	
Control Delay		19.0	26.4		22.4		14.2	71.5		12.3	38.1	
Queue Delay		0.0	0.0		0.0		0.0	0.0		0.2	0.0	
Total Delay		19.0	26.4		22.4		14.2	71.5		12.5	38.1	
LOS		B	C		C		B	E		B	D	
Approach Delay		20.9			22.4		30.8			17.5		
Approach LOS		C			C		C			B		
Queue Length 50th (m)		23.8	8.1		25.4		16.7	9.3		19.8	4.9	
Queue Length 95th (m)		41.5	21.2		#40.6		30.1	#34.5		31.8	#29.9	
Internal Link Dist (m)		75.4			68.9		45.4			81.5		
Turn Bay Length (m)			45.0								10.0	
Base Capacity (vph)		609	182		512		681	102		668	119	
Starvation Cap Reductn		0	0		0		0	0		62	0	
Spillback Cap Reductn		0	0		0		0	0		0	0	
Storage Cap Reductn		0	0		0		0	0		0	0	
Reduced v/c Ratio		0.39	0.44		0.72		0.29	0.79		0.52	0.64	

Intersection Summary												
Cycle Length: 75												
Actuated Cycle Length: 75												
Offset: 11 (15%), Referenced to phase 2:EBTL and 6:WBTL, Start of Green												
Natural Cycle: 55												
Control Type: Actuated-Coordinated												

Lanes, Volumes, Timings
3: Bank Street & Laurier Avenue West

2028 Future Background
PM Peak Hour

Lane Group	Ø1	Ø3	Ø5	Ø7
Lane Configurations				
Traffic Volume (vph)				
Future Volume (vph)				
Satd. Flow (prot)				
Fit Permitted				
Satd. Flow (perm)				
Satd. Flow (RTOR)				
Lane Group Flow (vph)				
Turn Type				
Protected Phases	1	3	5	7
Permitted Phases				
Detector Phase				
Switch Phase				
Minimum Initial (s)	1.0	1.0	1.0	1.0
Minimum Split (s)	3.0	3.0	3.0	3.0
Total Split (s)	5.0	5.0	5.0	5.0
Total Split (%)	7%	7%	7%	7%
Yellow Time (s)	2.0	2.0	2.0	2.0
All-Red Time (s)	0.0	0.0	0.0	0.0
Lost Time Adjust (s)				
Total Lost Time (s)				
Lead/Lag	Lead	Lead	Lead	Lead
Lead-Lag Optimize?	Yes	Yes	Yes	Yes
Recall Mode	None	None	None	None
Act Effct Green (s)				
Actuated g/C Ratio				
v/c Ratio				
Control Delay				
Queue Delay				
Total Delay				
LOS				
Approach Delay				
Approach LOS				
Queue Length 50th (m)				
Queue Length 95th (m)				
Internal Link Dist (m)				
Turn Bay Length (m)				
Base Capacity (vph)				
Starvation Cap Reductn				
Spillback Cap Reductn				
Storage Cap Reductn				
Reduced v/c Ratio				
Intersection Summary				

Lanes, Volumes, Timings
3: Bank Street & Laurier Avenue West

2028 Future Background
PM Peak Hour

Maximum v/c Ratio: 0.79
Intersection Signal Delay: 22.3
Intersection Capacity Utilization 73.7%
Analysis Period (min) 15
95th percentile volume exceeds capacity, queue may be longer.
Queue shown is maximum after two cycles.

Splits and Phases: 3: Bank Street & Laurier Avenue West

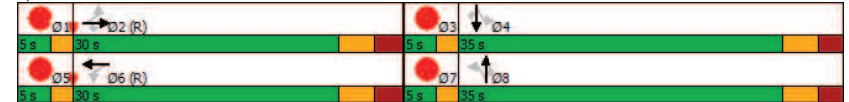

Lanes, Volumes, Timings
4: O'Connor Street & Laurier Avenue West

2028 Future Background
PM Peak Hour

Lane Group	EBL	EBT	EBR	WBL	WBT	WBR	NBL	NBT	NBR	SBL	SBT	SBR
Lane Configurations		↔	↔	↔	↔	↔	↔	↔	↔	↔	↔	↔
Traffic Volume (vph)	0	269	104	196	285	0	0	0	0	55	348	31
Future Volume (vph)	0	269	104	196	285	0	0	0	0	55	348	31
Satd. Flow (prot)	0	1347	0	1492	1571	0	0	0	0	0	4019	0
Fit Permitted				0.346							0.994	
Satd. Flow (perm)	0	1347	0	543	1571	0	0	0	0	0	3713	0
Satd. Flow (RTOR)												
Lane Group Flow (vph)	0	373	0	196	285	0	0	0	0	0	434	0
Turn Type		NA		pm+pt	NA					Perm	NA	
Protected Phases		2		9	6						4	
Permitted Phases				6						4		
Detector Phase		2		9	6					4	4	
Switch Phase												
Minimum Initial (s)		10.0		5.0	10.0					10.0	10.0	
Minimum Split (s)		16.9		10.8	16.9					16.7	16.7	
Total Split (s)		29.0		11.0	45.0					25.0	25.0	
Total Split (%)		38.7%		14.7%	60.0%					33.3%	33.3%	
Yellow Time (s)		3.3		3.3	3.3					3.3	3.3	
All-Red Time (s)		2.6		2.5	2.6					2.4	2.4	
Lost Time Adjust (s)		0.0		0.0	0.0						0.0	
Total Lost Time (s)		5.9		5.8	5.9						5.7	
Lead/Lag				Lead						Lag	Lag	
Lead-Lag Optimize?				Yes						Yes	Yes	
Recall Mode		C-Max		Max	C-Max					Max	Max	
Act Effct Green (s)		28.1		39.2	39.1						24.3	
Actuated g/C Ratio		0.37		0.52	0.52						0.32	
v/c Ratio		0.74		0.56	0.35						0.36	
Control Delay		23.1		17.4	12.0						10.7	
Queue Delay		0.0		0.0	0.0						0.0	
Total Delay		23.1		17.4	12.0						10.7	
LOS		C		B	B						B	
Approach Delay		23.1			14.2						10.7	
Approach LOS		C			B						B	
Queue Length 50th (m)		49.5		14.2	22.0						7.4	
Queue Length 95th (m)		m#82.1		25.6	37.3						9.8	
Internal Link Dist (m)		64.2			50.7			45.5			84.2	
Turn Bay Length (m)				15.0								
Base Capacity (vph)		504		349	819						1203	
Starvation Cap Reductn		0		0	0						0	
Spillback Cap Reductn		0		0	0						0	
Storage Cap Reductn		0		0	0						0	
Reduced v/c Ratio		0.74		0.56	0.35						0.36	

Intersection Summary	
Cycle Length: 75	
Actuated Cycle Length: 75	
Offset: 22 (29%), Referenced to phase 2:EBT and 6:WBTL, Start of Green	
Natural Cycle: 65	
Control Type: Actuated-Coordinated	

Lanes, Volumes, Timings
4: O'Connor Street & Laurier Avenue West

2028 Future Background
PM Peak Hour

Lane Group	Ø1	Ø3
Lane Configurations		
Traffic Volume (vph)		
Future Volume (vph)		
Satd. Flow (prot)		
Fit Permitted		
Satd. Flow (perm)		
Satd. Flow (RTOR)		
Lane Group Flow (vph)		
Turn Type		
Protected Phases	1	3
Permitted Phases		
Detector Phase		
Switch Phase		
Minimum Initial (s)	1.0	1.0
Minimum Split (s)	5.0	5.0
Total Split (s)	5.0	5.0
Total Split (%)	7%	7%
Yellow Time (s)	2.0	2.0
All-Red Time (s)	0.0	0.0
Lost Time Adjust (s)		
Total Lost Time (s)		
Lead/Lag	Lag	Lead
Lead-Lag Optimize?	Yes	Yes
Recall Mode	None	None
Act Effct Green (s)		
Actuated g/C Ratio		
v/c Ratio		
Control Delay		
Queue Delay		
Total Delay		
LOS		
Approach Delay		
Approach LOS		
Queue Length 50th (m)		
Queue Length 95th (m)		
Internal Link Dist (m)		
Turn Bay Length (m)		
Base Capacity (vph)		
Starvation Cap Reductn		
Spillback Cap Reductn		
Storage Cap Reductn		
Reduced v/c Ratio		

Intersection Summary	
Cycle Length: 75	
Actuated Cycle Length: 75	
Offset: 22 (29%), Referenced to phase 2:EBT and 6:WBTL, Start of Green	
Natural Cycle: 65	
Control Type: Actuated-Coordinated	

Lanes, Volumes, Timings
4: O'Connor Street & Laurier Avenue West

2028 Future Background
PM Peak Hour

Maximum v/c Ratio: 0.74
 Intersection Signal Delay: 15.6 Intersection LOS: B
 Intersection Capacity Utilization 66.5% ICU Level of Service C
 Analysis Period (min) 15
 # 95th percentile volume exceeds capacity, queue may be longer.
 Queue shown is maximum after two cycles.
 m Volume for 95th percentile queue is metered by upstream signal.

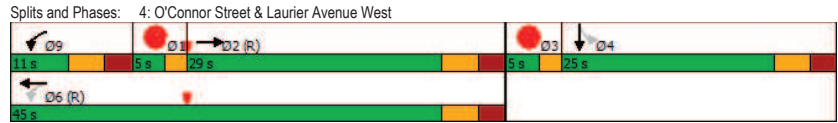

HCM 2010 TWSC
5: Laurier Avenue West & Site Access #1

2028 Future Background
PM Peak Hour

Intersection						
Int Delay, s/veh	3.6					
Movement	EBL	EBT	WBT	WBR	SBL	SBR
Lane Configurations		↕	↕		↕	↕
Traffic Vol, veh/h	3	339	316	4	39	88
Future Vol, veh/h	3	339	316	4	39	88
Conflicting Peds, #/hr	198	0	0	198	10	10
Sign Control	Free	Free	Free	Free	Stop	Stop
RT Channelized	-	None	-	None	-	None
Storage Length	-	-	-	-	0	-
Veh in Median Storage, #	-	0	0	-	0	-
Grade, %	-	0	0	-	0	-
Peak Hour Factor	100	100	100	100	100	100
Heavy Vehicles, %	2	2	2	2	2	2
Mvmt Flow	3	339	316	4	39	88
Major/Minor	Major1	Major2	Minor2			
Conflicting Flow All	518	0	0	871	526	
Stage 1	-	-	-	516	-	
Stage 2	-	-	-	355	-	
Critical Hdwy	4.12	-	-	6.42	6.22	
Critical Hdwy Stg 1	-	-	-	5.42	-	
Critical Hdwy Stg 2	-	-	-	5.42	-	
Follow-up Hdwy	2,218	-	-	3,518	3,318	
Pot Cap-1 Maneuver	1048	-	-	322	552	
Stage 1	-	-	-	599	-	
Stage 2	-	-	-	710	-	
Platoon blocked, %	-	-	-	-	-	
Mov Cap-1 Maneuver	855	-	-	213	446	
Mov Cap-2 Maneuver	-	-	-	213	-	
Stage 1	-	-	-	487	-	
Stage 2	-	-	-	579	-	
Approach	EB	WB	SB			
HCM Control Delay, s	0.1	0	22.2			
HCM LOS			C			
Minor Lane/Major Mvmt	EBL	EBT	WBT	WBR	SBLn1	
Capacity (veh/h)	855	-	-	-	334	
HCM Lane V/C Ratio	0.004	-	-	-	0.38	
HCM Control Delay (s)	9.2	0	-	-	22.2	
HCM Lane LOS	A	A	-	-	C	
HCM 95th %tile Q(veh)	0	-	-	-	1.7	

Appendix I

Synchro Intersection Worksheets – 2033 Future Background Conditions

Lanes, Volumes, Timings

2033 Future Background

1: Bank Street & Slater Street /Slater Street

AM Peak Hour



Lane Group	EBL	EBT	EBR	WBL	WBT	WBR	NBL	NBT	NBR	SBL	SBT	SBR
Lane Configurations		↕↕	↕					↕			↕	
Traffic Volume (vph)	22	899	90	0	0	0	0	217	23	14	242	0
Future Volume (vph)	22	899	90	0	0	0	0	217	23	14	242	0
Satd. Flow (prot)	0	2787	1335	0	0	0	0	1413	0	0	1566	0
Fit Permitted		0.999									0.979	
Satd. Flow (perm)	0	2774	876	0	0	0	0	1413	0	0	1519	0
Satd. Flow (RTOR)			62					8				
Lane Group Flow (vph)	0	921	90	0	0	0	0	240	0	0	256	0
Turn Type	pm+pt	NA	Perm					NA	Perm	NA		
Protected Phases	5	2						4			8	
Permitted Phases	2		2							8		
Detector Phase	5	2	2					4		8	8	
Switch Phase												
Minimum Initial (s)	5.0	10.0	10.0					10.0	10.0	10.0		
Minimum Split (s)	10.0	24.0	24.0					35.0	35.0	35.0		
Total Split (s)	12.0	40.0	40.0					35.0	35.0	35.0		
Total Split (%)	16.0%	53.3%	53.3%					46.7%	46.7%	46.7%		
Yellow Time (s)	3.3	3.3	3.3					3.3	3.3	3.3		
All-Red Time (s)	1.7	1.7	1.7					2.2	2.2	2.2		
Lost Time Adjust (s)		0.0	0.0					0.0	0.0	0.0		
Total Lost Time (s)		5.0	5.0					5.5		5.5		
Lead/Lag	Lead										Lag	
Lead-Lag Optimize?	Yes										Yes	
Recall Mode	Max	C-Max	C-Max					Max	Max	Max		
Act Effct Green (s)		35.0	35.0					29.5		29.5		
Actuated g/C Ratio		0.47	0.47					0.39		0.39		
v/c Ratio		0.71	0.20					0.43		0.43		
Control Delay		19.8	6.4					12.2		19.4		
Queue Delay		0.0	0.0					0.0		0.0		
Total Delay		19.8	6.4					12.2		19.4		
LOS		B	A					B		B		
Approach Delay		18.6						12.2		19.4		
Approach LOS		B						B		B		
Queue Length 50th (m)		52.0	2.1					8.7		25.7		
Queue Length 95th (m)		72.8	9.6					31.0		44.4		
Internal Link Dist (m)		64.9				157.3		81.5		43.1		
Turn Bay Length (m)			65.0									
Base Capacity (vph)		1295	441					560		597		
Starvation Cap Reductn		0	0					0		0		
Spillback Cap Reductn		0	0					0		0		
Storage Cap Reductn		0	0					0		0		
Reduced v/c Ratio		0.71	0.20					0.43		0.43		

Intersection Summary

Cycle Length: 75
Actuated Cycle Length: 75
Offset: 48 (64%), Referenced to phase 2:EBTL and 6:Hold, Start of Green
Natural Cycle: 60
Control Type: Actuated-Coordinated

Lanes, Volumes, Timings

2033 Future Background

1: Bank Street & Slater Street /Slater Street

AM Peak Hour

Lane Group	Ø6
Lane Configurations	
Traffic Volume (vph)	
Future Volume (vph)	
Satd. Flow (prot)	
Fit Permitted	
Satd. Flow (perm)	
Satd. Flow (RTOR)	
Lane Group Flow (vph)	
Turn Type	
Protected Phases	6
Permitted Phases	
Detector Phase	
Switch Phase	
Minimum Initial (s)	1.0
Minimum Split (s)	3.0
Total Split (s)	28.0
Total Split (%)	37%
Yellow Time (s)	2.0
All-Red Time (s)	0.0
Lost Time Adjust (s)	
Total Lost Time (s)	
Lead/Lag	Lag
Lead-Lag Optimize?	Yes
Recall Mode	C-Max
Act Effct Green (s)	
Actuated g/C Ratio	
v/c Ratio	
Control Delay	
Queue Delay	
Total Delay	
LOS	
Approach Delay	
Approach LOS	
Queue Length 50th (m)	
Queue Length 95th (m)	
Internal Link Dist (m)	
Turn Bay Length (m)	
Base Capacity (vph)	
Starvation Cap Reductn	
Spillback Cap Reductn	
Storage Cap Reductn	
Reduced v/c Ratio	

Intersection Summary

Cycle Length: 75
Actuated Cycle Length: 75
Offset: 48 (64%), Referenced to phase 2:EBTL and 6:Hold, Start of Green
Natural Cycle: 60
Control Type: Actuated-Coordinated

Lanes, Volumes, Timings
1: Bank Street & Slater Street /Slater Street

2033 Future Background
AM Peak Hour

Maximum v/c Ratio: 0.71	Intersection LOS: B
Intersection Signal Delay: 17.7	ICU Level of Service C
Intersection Capacity Utilization 70.3%	
Analysis Period (min) 15	



Lanes, Volumes, Timings
2: O'Connor Street & Slater Street

2033 Future Background
AM Peak Hour

Lane Group	EBL	EBT	EBR	WBL	WBT	WBR	NBL	NBT	NBR	SBL	SBT	SBR
Lane Configurations		↑↑	↑							↓	↓↑↑	
Traffic Volume (vph)	0	706	55	0	0	0	0	0	0	119	240	0
Future Volume (vph)	0	706	55	0	0	0	0	0	0	119	240	0
Satd. Flow (prot)	0	2767	1297	0	0	0	0	0	0	1463	4165	0
Fit Permitted										0.950		
Satd. Flow (perm)	0	2767	1035	0	0	0	0	0	0	941	4165	0
Satd. Flow (RTOR)										51		
Lane Group Flow (vph)	0	706	55	0	0	0	0	0	0	119	240	0
Turn Type		NA	Perm							Perm	NA	
Protected Phases		4									6	
Permitted Phases			4									6
Detector Phase		4	4							6	6	
Switch Phase												
Minimum Initial (s)		10.0	10.0							10.0	10.0	
Minimum Split (s)		30.5	30.5							22.5	22.5	
Total Split (s)		41.0	41.0							34.0	34.0	
Total Split (%)		54.7%	54.7%							45.3%	45.3%	
Yellow Time (s)		3.3	3.3							3.3	3.3	
All-Red Time (s)		2.2	2.2							2.2	2.2	
Lost Time Adjust (s)		0.0	0.0							0.0	0.0	
Total Lost Time (s)		5.5	5.5							5.5	5.5	
Lead/Lag												
Lead-Lag Optimize?												
Recall Mode		C-Max	C-Max							Max	Max	
Act Effct Green (s)		35.5	35.5							28.5	28.5	
Actuated g/C Ratio		0.47	0.47							0.38	0.38	
v/c Ratio		0.54	0.11							0.31	0.15	
Control Delay		2.4	1.6							12.4	15.6	
Queue Delay		0.0	0.0							0.0	0.0	
Total Delay		2.4	1.6							12.4	15.6	
LOS		A	A							B	B	
Approach Delay		2.4									14.6	
Approach LOS		A									B	
Queue Length 50th (m)		2.7	0.4							6.3	7.9	
Queue Length 95th (m)		3.5	m0.6							17.9	12.9	
Internal Link Dist (m)		157.3			58.3			84.2			37.7	
Turn Bay Length (m)			30.0									
Base Capacity (vph)		1309	489							389	1582	
Starvation Cap Reductn		0	0							0	0	
Spillback Cap Reductn		0	0							0	0	
Storage Cap Reductn		0	0							0	0	
Reduced v/c Ratio		0.54	0.11							0.31	0.15	

Intersection Summary	
Cycle Length:	75
Actuated Cycle Length:	75
Offset:	48 (64%), Referenced to phase 4:EBT, Start of Green
Natural Cycle:	55
Control Type:	Actuated-Coordinated

Lanes, Volumes, Timings
2: O'Connor Street & Slater Street

2033 Future Background
AM Peak Hour

Maximum v/c Ratio: 0.54	Intersection LOS: A
Intersection Signal Delay: 6.3	ICU Level of Service A
Intersection Capacity Utilization 46.2%	
Analysis Period (min) 15	

m Volume for 95th percentile queue is metered by upstream signal.

Splits and Phases: 2: O'Connor Street & Slater Street

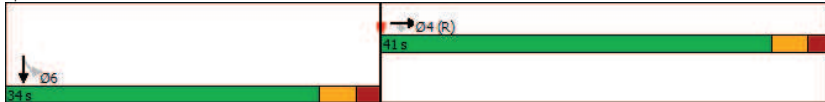

Lanes, Volumes, Timings
3: Bank Street & Laurier Avenue West

2033 Future Background
AM Peak Hour

Lane Group	EBL	EBT	EBR	WBL	WBT	WBR	NBL	NBT	NBR	SBL	SBT	SBR
Lane Configurations		↖	↗		↖	↗		↖	↗		↖	↗
Traffic Volume (vph)	2	306	51	0	242	41	1	192	140	12	266	58
Future Volume (vph)	2	306	51	0	242	41	1	192	140	12	266	58
Satd. Flow (prot)	0	1566	1335	0	1348	0	0	1382	1335	0	1484	1335
Fit Permitted		0.998						0.999			0.987	
Satd. Flow (perm)	0	1560	498	0	1348	0	0	1378	479	0	1437	435
Satd. Flow (RTOR)												
Lane Group Flow (vph)	0	308	51	0	283	0	0	193	140	0	278	58
Turn Type	Perm	NA	Perm	NA	Perm	NA	Perm	NA	Perm	Perm	NA	Perm
Protected Phases		2			6			8			4	
Permitted Phases	2		2				8		8	4		4
Detector Phase	2	2	2		6		8	8	8	4	4	4
Switch Phase												
Minimum Initial (s)	10.0	10.0	10.0		10.0		10.0	10.0	10.0	10.0	10.0	10.0
Minimum Split (s)	23.9	23.9	23.9		23.9		23.6	23.6	23.6	23.6	23.6	23.6
Total Split (s)	27.0	27.0	27.0		27.0		38.0	38.0	38.0	38.0	38.0	38.0
Total Split (%)	36.0%	36.0%	36.0%		36.0%		50.7%	50.7%	50.7%	50.7%	50.7%	50.7%
Yellow Time (s)	3.3	3.3	3.3		3.3		3.3	3.3	3.3	3.3	3.3	3.3
All-Red Time (s)	2.6	2.6	2.6		2.6		2.3	2.3	2.3	2.3	2.3	2.3
Lost Time Adjust (s)		0.0	0.0		0.0		0.0	0.0	0.0	0.0	0.0	0.0
Total Lost Time (s)		5.9	5.9		5.9		5.6	5.6	5.6	5.6	5.6	5.6
Lead/Lag	Lag	Lag	Lag		Lag		Lag	Lag	Lag	Lag	Lag	Lag
Lead-Lag Optimize?	Yes	Yes	Yes		Yes		Yes	Yes	Yes	Yes	Yes	Yes
Recall Mode	C-Max	C-Max	C-Max		C-Max		Max	Max	Max	Max	Max	Max
Act Effct Green (s)	26.1	26.1	26.1		26.1		37.4	37.4	37.4	37.4	37.4	37.4
Actuated g/C Ratio	0.35	0.35			0.35		0.50	0.50		0.50	0.50	
v/c Ratio	0.57	0.29			0.60		0.28	0.59		0.39	0.27	
Control Delay	24.9	23.5			41.2		12.4	26.0		8.1	9.7	
Queue Delay	0.0	0.0			0.0		0.0	0.0		0.0	0.0	
Total Delay	24.9	23.5			41.2		12.4	26.0		8.1	9.7	
LOS	C	C			D		B	C		A	A	
Approach Delay	24.7				41.2		18.1			8.4		
Approach LOS	C				D		B			A		
Queue Length 50th (m)	34.8	5.2			40.3		15.0	13.2		10.7	2.3	
Queue Length 95th (m)	58.5	14.2			63.7		27.4	#38.6		18.9	6.0	
Internal Link Dist (m)	75.4				68.9		45.4			81.5		
Turn Bay Length (m)			45.0									10.0
Base Capacity (vph)		542	173		469		687	238		716	216	
Starvation Cap Reductn	0	0			0		0	0		0	0	
Spillback Cap Reductn	0	0			0		0	0		0	0	
Storage Cap Reductn	0	0			0		0	0		0	0	
Reduced v/c Ratio		0.57	0.29		0.60		0.28	0.59		0.39	0.27	

Intersection Summary												
Cycle Length: 75												
Actuated Cycle Length: 75												
Offset: 40 (53%), Referenced to phase 2:EBTL and 6:WBT, Start of Green												
Natural Cycle: 60												
Control Type: Actuated-Coordinated												

Lanes, Volumes, Timings
3: Bank Street & Laurier Avenue West

2033 Future Background
AM Peak Hour

Lane Group	Ø1	Ø3	Ø5	Ø7
Lane Configurations				
Traffic Volume (vph)				
Future Volume (vph)				
Satd. Flow (prot)				
Fit Permitted				
Satd. Flow (perm)				
Satd. Flow (RTOR)				
Lane Group Flow (vph)				
Turn Type				
Protected Phases	1	3	5	7
Permitted Phases				
Detector Phase				
Switch Phase				
Minimum Initial (s)	1.0	1.0	1.0	1.0
Minimum Split (s)	3.0	3.0	3.0	3.0
Total Split (s)	5.0	5.0	5.0	5.0
Total Split (%)	7%	7%	7%	7%
Yellow Time (s)	2.0	2.0	2.0	2.0
All-Red Time (s)	0.0	0.0	0.0	0.0
Lost Time Adjust (s)				
Total Lost Time (s)				
Lead/Lag	Lead	Lead	Lead	Lead
Lead-Lag Optimize?	Yes	Yes	Yes	Yes
Recall Mode	None	None	None	None
Act Effct Green (s)				
Actuated g/C Ratio				
v/c Ratio				
Control Delay				
Queue Delay				
Total Delay				
LOS				
Approach Delay				
Approach LOS				
Queue Length 50th (m)				
Queue Length 95th (m)				
Internal Link Dist (m)				
Turn Bay Length (m)				
Base Capacity (vph)				
Starvation Cap Reductn				
Spillback Cap Reductn				
Storage Cap Reductn				
Reduced v/c Ratio				
Intersection Summary				

Lanes, Volumes, Timings
3: Bank Street & Laurier Avenue West

2033 Future Background
AM Peak Hour

Maximum v/c Ratio: 0.60
Intersection Signal Delay: 22.4
Intersection Capacity Utilization 69.3%
Analysis Period (min) 15
95th percentile volume exceeds capacity, queue may be longer.
Queue shown is maximum after two cycles.

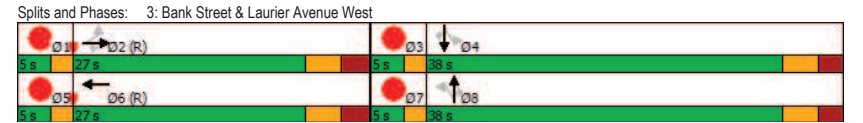

Lanes, Volumes, Timings
4: O'Connor Street & Laurier Avenue West

2033 Future Background
AM Peak Hour

Lane Group	EBL	EBT	EBR	WBL	WBT	WBR	NBL	NBT	NBR	SBL	SBT	SBR
Lane Configurations		↔	↔	↔	↔						↔↔↔	
Traffic Volume (vph)	0	217	149	146	305	0	0	0	0	28	229	26
Future Volume (vph)	0	217	149	146	305	0	0	0	0	28	229	26
Satd. Flow (prot)	0	1262	0	1492	1511	0	0	0	0	0	3858	0
Fit Permitted				0.353							0.995	
Satd. Flow (perm)	0	1262	0	554	1511	0	0	0	0	0	3631	0
Satd. Flow (RTOR)												
Lane Group Flow (vph)	0	366	0	146	305	0	0	0	0	0	283	0
Turn Type		NA		pm+pt	NA					Perm	NA	
Protected Phases		2		9	6							4
Permitted Phases				6							4	
Detector Phase		2		9	6						4	4
Switch Phase												
Minimum Initial (s)		10.0		5.0	10.0					10.0	10.0	
Minimum Split (s)		16.9		10.8	16.9					16.7	16.7	
Total Split (s)		29.0		11.0	45.0					25.0	25.0	
Total Split (%)		38.7%		14.7%	60.0%					33.3%	33.3%	
Yellow Time (s)		3.3		3.3	3.3					3.3	3.3	
All-Red Time (s)		2.6		2.5	2.6					2.4	2.4	
Lost Time Adjust (s)		0.0		0.0	0.0						0.0	
Total Lost Time (s)		5.9		5.8	5.9						5.7	
Lead/Lag				Lead						Lag	Lag	
Lead-Lag Optimize?				Yes						Yes	Yes	
Recall Mode		C-Max		Max	C-Max					Max	Max	
Act Effct Green (s)		28.1		39.2	39.1						24.3	
Actuated g/C Ratio		0.37		0.52	0.52						0.32	
v/c Ratio		0.78		0.41	0.39						0.24	
Control Delay		30.9		13.4	12.6						9.3	
Queue Delay		0.0		0.0	0.0						0.0	
Total Delay		30.9		13.4	12.6						9.3	
LOS		C		B	B						A	
Approach Delay		30.9			12.9						9.3	
Approach LOS		C			B						A	
Queue Length 50th (m)		50.1		10.2	24.1						4.5	
Queue Length 95th (m)		#88.4		19.5	41.1						6.9	
Internal Link Dist (m)		64.2			50.7			45.5			84.2	
Turn Bay Length (m)				15.0								
Base Capacity (vph)		472		354	787						1176	
Starvation Cap Reductn		0		0	0						0	
Spillback Cap Reductn		0		0	0						0	
Storage Cap Reductn		0		0	0						0	
Reduced v/c Ratio		0.78		0.41	0.39						0.24	

Intersection Summary	
Cycle Length: 75	
Actuated Cycle Length: 75	
Offset: 63 (84%), Referenced to phase 2:EBT and 6:WBTL, Start of Green	
Natural Cycle: 65	
Control Type: Actuated-Coordinated	

Lanes, Volumes, Timings
4: O'Connor Street & Laurier Avenue West

2033 Future Background
AM Peak Hour

Lane Group	Ø1	Ø3
Lane Configurations		
Traffic Volume (vph)		
Future Volume (vph)		
Satd. Flow (prot)		
Fit Permitted		
Satd. Flow (perm)		
Satd. Flow (RTOR)		
Lane Group Flow (vph)		
Turn Type		
Protected Phases	1	3
Permitted Phases		
Detector Phase		
Switch Phase		
Minimum Initial (s)	1.0	1.0
Minimum Split (s)	5.0	5.0
Total Split (s)	5.0	5.0
Total Split (%)	7%	7%
Yellow Time (s)	2.0	2.0
All-Red Time (s)	0.0	0.0
Lost Time Adjust (s)		
Total Lost Time (s)		
Lead/Lag	Lag	Lead
Lead-Lag Optimize?	Yes	Yes
Recall Mode	None	None
Act Effct Green (s)		
Actuated g/C Ratio		
v/c Ratio		
Control Delay		
Queue Delay		
Total Delay		
LOS		
Approach Delay		
Approach LOS		
Queue Length 50th (m)		
Queue Length 95th (m)		
Internal Link Dist (m)		
Turn Bay Length (m)		
Base Capacity (vph)		
Starvation Cap Reductn		
Spillback Cap Reductn		
Storage Cap Reductn		
Reduced v/c Ratio		

Intersection Summary	
Cycle Length: 75	
Actuated Cycle Length: 75	
Offset: 63 (84%), Referenced to phase 2:EBT and 6:WBTL, Start of Green	
Natural Cycle: 65	
Control Type: Actuated-Coordinated	

Lanes, Volumes, Timings
4: O'Connor Street & Laurier Avenue West

2033 Future Background
AM Peak Hour

Maximum v/c Ratio: 0.78	Intersection LOS: B
Intersection Signal Delay: 18.0	ICU Level of Service B
Intersection Capacity Utilization 63.2%	
Analysis Period (min) 15	
# 95th percentile volume exceeds capacity, queue may be longer.	
Queue shown is maximum after two cycles.	

Splits and Phases: 4: O'Connor Street & Laurier Avenue West

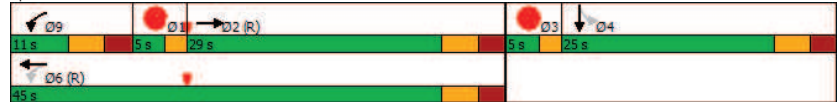

HCM 2010 TWSC
5: Laurier Avenue West & Site Access #1

2033 Future Background
AM Peak Hour

Intersection						
Int Delay, s/veh	1.2					
Movement	EBL	EBT	WBT	WBR	SBL	SBR
Lane Configurations		↕	↕		↕	↕
Traffic Vol, veh/h	104	458	341	63	2	3
Future Vol, veh/h	104	458	341	63	2	3
Conflicting Peds, #/hr	198	0	0	198	10	10
Sign Control	Free	Free	Free	Free	Stop	Stop
RT Channelized	-	None	-	None	-	None
Storage Length	-	-	-	-	0	-
Veh in Median Storage, #	-	0	0	-	0	-
Grade, %	-	0	0	-	0	-
Peak Hour Factor	100	100	100	100	100	100
Heavy Vehicles, %	2	2	2	2	2	2
Mvmt Flow	104	458	341	63	2	3
Major/Minor	Major1	Major2	Minor2			
Conflicting Flow All	602	0	0	1247	581	
Stage 1	-	-	-	571	-	
Stage 2	-	-	-	676	-	
Critical Hdwy	4.12	-	-	6.42	6.22	
Critical Hdwy Stg 1	-	-	-	5.42	-	
Critical Hdwy Stg 2	-	-	-	5.42	-	
Follow-up Hdwy	2,218	-	-	3,518	3,318	
Pot Cap-1 Maneuver	975	-	-	192	514	
Stage 1	-	-	-	565	-	
Stage 2	-	-	-	505	-	
Platoon blocked, %	-	-	-	-	-	
Mov Cap-1 Maneuver	795	-	-	105	415	
Mov Cap-2 Maneuver	-	-	-	105	-	
Stage 1	-	-	-	380	-	
Stage 2	-	-	-	412	-	
Approach	EB	WB	SB			
HCM Control Delay, s	1.9	0	24.5			
HCM LOS			C			
Minor Lane/Major Mvmt	EBL	EBT	WBT	WBR	SBLn1	
Capacity (veh/h)	795	-	-	-	190	
HCM Lane V/C Ratio	0.131	-	-	-	0.026	
HCM Control Delay (s)	10.2	0	-	-	24.5	
HCM Lane LOS	B	A	-	-	C	
HCM 95th %tile Q(veh)	0.4	-	-	-	0.1	

Lanes, Volumes, Timings

2033 Future Background

1: Bank Street & Slater Street /Slater Street

PM Peak Hour



Lane Group	EBL	EBT	EBR	WBL	WBT	WBR	NBL	NBT	NBR	SBL	SBT	SBR
Lane Configurations		↕↕	↕					↕			↕	
Traffic Volume (vph)	25	858	154	0	0	0	0	256	19	13	245	0
Future Volume (vph)	25	858	154	0	0	0	0	256	19	13	245	0
Satd. Flow (prot)	0	2910	1335	0	0	0	0	1451	0	0	1461	0
Fit Permitted		0.999									0.980	
Satd. Flow (perm)	0	2890	940	0	0	0	0	1451	0	0	1420	0
Satd. Flow (RTOR)			43					6				
Lane Group Flow (vph)	0	883	154	0	0	0	0	275	0	0	258	0
Turn Type	pm+pt	NA	Perm					NA	Perm	NA		
Protected Phases	5	2						4			8	
Permitted Phases	2		2							8		
Detector Phase	5	2	2					4		8	8	
Switch Phase												
Minimum Initial (s)	5.0	10.0	10.0					10.0	10.0	10.0		
Minimum Split (s)	10.0	24.0	24.0					35.0	35.0	35.0		
Total Split (s)	12.0	40.0	40.0					35.0	35.0	35.0		
Total Split (%)	16.0%	53.3%	53.3%					46.7%	46.7%	46.7%		
Yellow Time (s)	3.3	3.3	3.3					3.3	3.3	3.3		
All-Red Time (s)	1.7	1.7	1.7					2.2	2.2	2.2		
Lost Time Adjust (s)		0.0	0.0					0.0	0.0	0.0		
Total Lost Time (s)		5.0	5.0					5.5		5.5		
Lead/Lag	Lead										Lag	
Lead-Lag Optimize?	Yes										Yes	
Recall Mode	Max	C-Max	C-Max					Max	Max	Max		
Act Effct Green (s)		35.0	35.0					29.5		29.5		
Actuated g/C Ratio		0.47	0.47					0.39		0.39		
v/c Ratio		0.65	0.33					0.48		0.46		
Control Delay		18.2	11.4					13.7		20.3		
Queue Delay		0.0	0.0					0.0		0.0		
Total Delay		18.2	11.4					13.7		20.3		
LOS		B	B					B		C		
Approach Delay		17.2						13.7		20.3		
Approach LOS		B						B		C		
Queue Length 50th (m)		47.9	9.0					13.8		26.3		
Queue Length 95th (m)		66.9	21.6					m21.1		46.0		
Internal Link Dist (m)		64.9				157.3		81.5		43.1		
Turn Bay Length (m)			65.0									
Base Capacity (vph)		1350	461					574		558		
Starvation Cap Reductn		0	0					0		0		
Spillback Cap Reductn		0	0					0		0		
Storage Cap Reductn		0	0					0		0		
Reduced v/c Ratio		0.65	0.33					0.48		0.46		

Intersection Summary

Cycle Length: 75

Actuated Cycle Length: 75

Offset: 20 (27%), Referenced to phase 2:EBTL and 6:Hold, Start of Green

Natural Cycle: 60

Control Type: Actuated-Coordinated

Lanes, Volumes, Timings

2033 Future Background

1: Bank Street & Slater Street /Slater Street

PM Peak Hour

Lane Group	Ø6
Lane Configurations	
Traffic Volume (vph)	
Future Volume (vph)	
Satd. Flow (prot)	
Fit Permitted	
Satd. Flow (perm)	
Satd. Flow (RTOR)	
Lane Group Flow (vph)	
Turn Type	
Protected Phases	6
Permitted Phases	
Detector Phase	
Switch Phase	
Minimum Initial (s)	1.0
Minimum Split (s)	3.0
Total Split (s)	28.0
Total Split (%)	37%
Yellow Time (s)	2.0
All-Red Time (s)	0.0
Lost Time Adjust (s)	
Total Lost Time (s)	
Lead/Lag	Lag
Lead-Lag Optimize?	Yes
Recall Mode	C-Max
Act Effct Green (s)	
Actuated g/C Ratio	
v/c Ratio	
Control Delay	
Queue Delay	
Total Delay	
LOS	
Approach Delay	
Approach LOS	
Queue Length 50th (m)	
Queue Length 95th (m)	
Internal Link Dist (m)	
Turn Bay Length (m)	
Base Capacity (vph)	
Starvation Cap Reductn	
Spillback Cap Reductn	
Storage Cap Reductn	
Reduced v/c Ratio	

Intersection Summary

Lanes, Volumes, Timings
1: Bank Street & Slater Street /Slater Street

2033 Future Background
PM Peak Hour

Maximum v/c Ratio: 0.65	Intersection LOS: B
Intersection Signal Delay: 17.1	ICU Level of Service C
Intersection Capacity Utilization 68.3%	
Analysis Period (min) 15	

m Volume for 95th percentile queue is metered by upstream signal.

Splits and Phases: 1: Bank Street & Slater Street /Slater Street

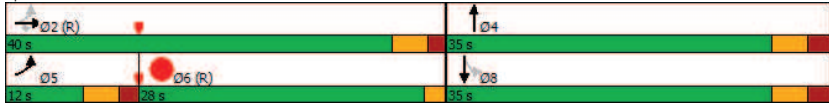

Lanes, Volumes, Timings
2: O'Connor Street & Slater Street

2033 Future Background
PM Peak Hour

Lane Group	EBL	EBT	EBR	WBL	WBT	WBR	NBL	NBT	NBR	SBL	SBT	SBR
Lane Configurations		↑↑	↑							↓	↓↑	↓
Traffic Volume (vph)	0	827	61	0	0	0	0	0	0	105	360	0
Future Volume (vph)	0	827	61	0	0	0	0	0	0	105	360	0
Satd. Flow (prot)	0	2899	1322	0	0	0	0	0	0	1436	4288	0
Fit Permitted										0.950		
Satd. Flow (perm)	0	2899	1060	0	0	0	0	0	0	975	4288	0
Satd. Flow (RTOR)										54		
Lane Group Flow (vph)	0	827	61	0	0	0	0	0	0	105	360	0
Turn Type		NA	Perm							Perm	NA	
Protected Phases		4									6	
Permitted Phases			4								6	
Detector Phase		4	4							6	6	
Switch Phase												
Minimum Initial (s)		10.0	10.0							10.0	10.0	
Minimum Split (s)		30.5	30.5							22.5	22.5	
Total Split (s)		45.0	45.0							30.0	30.0	
Total Split (%)		60.0%	60.0%							40.0%	40.0%	
Yellow Time (s)		3.3	3.3							3.3	3.3	
All-Red Time (s)		2.2	2.2							2.2	2.2	
Lost Time Adjust (s)		0.0	0.0							0.0	0.0	
Total Lost Time (s)		5.5	5.5							5.5	5.5	
Lead/Lag												
Lead-Lag Optimize?												
Recall Mode		C-Max	C-Max							Max	Max	
Act Effct Green (s)		39.5	39.5							24.5	24.5	
Actuated g/C Ratio		0.53	0.53							0.33	0.33	
v/c Ratio		0.54	0.11							0.30	0.26	
Control Delay		3.7	2.9							12.9	19.2	
Queue Delay		0.0	0.0							0.0	0.0	
Total Delay		3.7	2.9							12.9	19.2	
LOS		A	A							B	B	
Approach Delay		3.7									17.8	
Approach LOS		A									B	
Queue Length 50th (m)		6.3	0.9							5.1	13.5	
Queue Length 95th (m)		8.0	m1.4							16.4	20.2	
Internal Link Dist (m)		157.3				58.3		84.2			37.7	
Turn Bay Length (m)			30.0									
Base Capacity (vph)		1526	558							354	1400	
Starvation Cap Reductn		0	0							0	0	
Spillback Cap Reductn		0	0							0	0	
Storage Cap Reductn		0	0							0	0	
Reduced v/c Ratio		0.54	0.11							0.30	0.26	

Intersection Summary	
Cycle Length: 75	
Actuated Cycle Length: 75	
Offset: 12 (16%), Referenced to phase 4:EBT, Start of Green	
Natural Cycle: 55	
Control Type: Actuated-Coordinated	

Lanes, Volumes, Timings
2: O'Connor Street & Slater Street

2033 Future Background
PM Peak Hour

Maximum v/c Ratio: 0.54	Intersection LOS: A
Intersection Signal Delay: 8.5	ICU Level of Service A
Intersection Capacity Utilization 50.1%	
Analysis Period (min) 15	
m Volume for 95th percentile queue is metered by upstream signal.	

Splits and Phases: 2: O'Connor Street & Slater Street

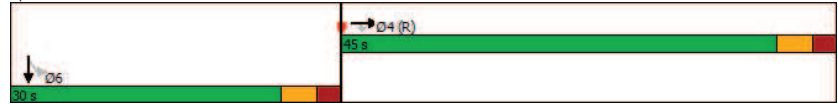

Lanes, Volumes, Timings
3: Bank Street & Laurier Avenue West

2033 Future Background
PM Peak Hour

Lane Group	EBL	EBT	EBR	WBL	WBT	WBR	NBL	NBT	NBR	SBL	SBT	SBR
Lane Configurations		↕	↕		↕			↕	↕		↕	↕
Traffic Volume (vph)	0	240	80	2	285	81	1	207	81	18	315	76
Future Volume (vph)	0	240	80	2	285	81	1	207	81	18	315	76
Satd. Flow (prot)	0	1571	1335	0	1325	0	0	1491	1335	0	1537	1335
Fit Permitted					0.999			0.999			0.980	
Satd. Flow (perm)	0	1571	471	0	1321	0	0	1487	223	0	1462	261
Satd. Flow (RTOR)												
Lane Group Flow (vph)	0	240	80	0	368	0	0	208	81	0	333	76
Turn Type		NA	Perm	Perm	NA		Perm	NA	Perm	Perm	NA	Perm
Protected Phases		2			6			8			4	
Permitted Phases	2		2	6			8		8	4		4
Detector Phase	2	2	2	6	6		8	8	8	4	4	4
Switch Phase												
Minimum Initial (s)	10.0	10.0	10.0	10.0	10.0		10.0	10.0	10.0	10.0	10.0	10.0
Minimum Split (s)	23.9	23.9	23.9	23.9	23.9		23.6	23.6	23.6	23.6	23.6	23.6
Total Split (s)	30.0	30.0	30.0	30.0	30.0		35.0	35.0	35.0	35.0	35.0	35.0
Total Split (%)	40.0%	40.0%	40.0%	40.0%	40.0%		46.7%	46.7%	46.7%	46.7%	46.7%	46.7%
Yellow Time (s)	3.3	3.3	3.3	3.3	3.3		3.3	3.3	3.3	3.3	3.3	3.3
All-Red Time (s)	2.6	2.6	2.6	2.6	2.6		2.3	2.3	2.3	2.3	2.3	2.3
Lost Time Adjust (s)		0.0	0.0		0.0			0.0	0.0		0.0	0.0
Total Lost Time (s)		5.9	5.9		5.9			5.6	5.6		5.6	5.6
Lead/Lag	Lag	Lag	Lag	Lag	Lag		Lag	Lag	Lag	Lag	Lag	Lag
Lead-Lag Optimize?	Yes	Yes	Yes	Yes	Yes		Yes	Yes	Yes	Yes	Yes	Yes
Recall Mode	C-Max	C-Max	C-Max	C-Max	C-Max		Max	Max	Max	Max	Max	Max
Act Effct Green (s)	29.1	29.1	29.1	29.1	29.1		34.4	34.4	34.4	34.4	34.4	34.4
Actuated g/C Ratio	0.39	0.39		0.39			0.46	0.46		0.46	0.46	0.46
v/c Ratio	0.39	0.44		0.72			0.30	0.79		0.50	0.64	
Control Delay		19.0	26.4		22.4		14.4	71.5		12.4	37.7	
Queue Delay		0.0	0.0		0.0		0.0	0.0		0.2	0.0	
Total Delay		19.0	26.4		22.4		14.4	71.5		12.6	37.7	
LOS		B	C		C		B	E		B	D	
Approach Delay		20.9			22.4		30.4			17.3		
Approach LOS		C			C		C			B		
Queue Length 50th (m)		23.8	8.1		25.4		17.7	9.3		20.5	4.9	
Queue Length 95th (m)		41.5	21.2		#40.6		31.7	#34.5		32.7	#29.4	
Internal Link Dist (m)		75.4			68.9		45.4			81.5		
Turn Bay Length (m)			45.0								10.0	
Base Capacity (vph)		609	182		512		682	102		670	119	
Starvation Cap Reductn		0	0		0		0	0		56	0	
Spillback Cap Reductn		0	0		0		0	0		0	0	
Storage Cap Reductn		0	0		0		0	0		0	0	
Reduced v/c Ratio		0.39	0.44		0.72		0.30	0.79		0.54	0.64	

Intersection Summary												
Cycle Length: 75												
Actuated Cycle Length: 75												
Offset: 11 (15%), Referenced to phase 2:EBTL and 6:WBTL, Start of Green												
Natural Cycle: 55												
Control Type: Actuated-Coordinated												

Lanes, Volumes, Timings
3: Bank Street & Laurier Avenue West

2033 Future Background
PM Peak Hour

Lane Group	Ø1	Ø3	Ø5	Ø7
Lane Configurations				
Traffic Volume (vph)				
Future Volume (vph)				
Satd. Flow (prot)				
Fit Permitted				
Satd. Flow (perm)				
Satd. Flow (RTOR)				
Lane Group Flow (vph)				
Turn Type				
Protected Phases	1	3	5	7
Permitted Phases				
Detector Phase				
Switch Phase				
Minimum Initial (s)	1.0	1.0	1.0	1.0
Minimum Split (s)	3.0	3.0	3.0	3.0
Total Split (s)	5.0	5.0	5.0	5.0
Total Split (%)	7%	7%	7%	7%
Yellow Time (s)	2.0	2.0	2.0	2.0
All-Red Time (s)	0.0	0.0	0.0	0.0
Lost Time Adjust (s)				
Total Lost Time (s)				
Lead/Lag	Lead	Lead	Lead	Lead
Lead-Lag Optimize?	Yes	Yes	Yes	Yes
Recall Mode	None	None	None	None
Act Effct Green (s)				
Actuated g/C Ratio				
v/c Ratio				
Control Delay				
Queue Delay				
Total Delay				
LOS				
Approach Delay				
Approach LOS				
Queue Length 50th (m)				
Queue Length 95th (m)				
Internal Link Dist (m)				
Turn Bay Length (m)				
Base Capacity (vph)				
Starvation Cap Reductn				
Spillback Cap Reductn				
Storage Cap Reductn				
Reduced v/c Ratio				
Intersection Summary				

Lanes, Volumes, Timings
3: Bank Street & Laurier Avenue West

2033 Future Background
PM Peak Hour

Maximum v/c Ratio: 0.79
Intersection Signal Delay: 22.2
Intersection Capacity Utilization 74.6%
Analysis Period (min) 15
95th percentile volume exceeds capacity, queue may be longer.
Queue shown is maximum after two cycles.

Splits and Phases: 3: Bank Street & Laurier Avenue West

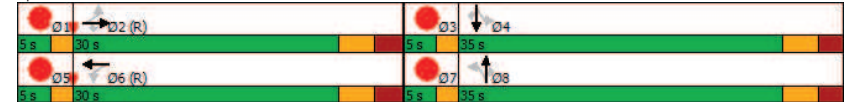

Lanes, Volumes, Timings
4: O'Connor Street & Laurier Avenue West

2033 Future Background
PM Peak Hour

Lane Group	EBL	EBT	EBR	WBL	WBT	WBR	NBL	NBT	NBR	SBL	SBT	SBR
Lane Configurations		↔		↔	↔						↔↔↔	
Traffic Volume (vph)	0	269	104	196	285	0	0	0	0	55	348	31
Future Volume (vph)	0	269	104	196	285	0	0	0	0	55	348	31
Satd. Flow (prot)	0	1347	0	1492	1571	0	0	0	0	0	4019	0
Fit Permitted				0.346							0.994	
Satd. Flow (perm)	0	1347	0	543	1571	0	0	0	0	0	3713	0
Satd. Flow (RTOR)												
Lane Group Flow (vph)	0	373	0	196	285	0	0	0	0	0	434	0
Turn Type		NA		pm+pt	NA					Perm	NA	
Protected Phases		2		9	6							4
Permitted Phases				6							4	
Detector Phase		2		9	6						4	4
Switch Phase												
Minimum Initial (s)		10.0		5.0	10.0					10.0	10.0	
Minimum Split (s)		16.9		10.8	16.9					16.7	16.7	
Total Split (s)		29.0		11.0	45.0					25.0	25.0	
Total Split (%)		38.7%		14.7%	60.0%					33.3%	33.3%	
Yellow Time (s)		3.3		3.3	3.3					3.3	3.3	
All-Red Time (s)		2.6		2.5	2.6					2.4	2.4	
Lost Time Adjust (s)		0.0		0.0	0.0						0.0	
Total Lost Time (s)		5.9		5.8	5.9						5.7	
Lead/Lag				Lead						Lag	Lag	
Lead-Lag Optimize?				Yes						Yes	Yes	
Recall Mode		C-Max		Max	C-Max					Max	Max	
Act Effct Green (s)		28.1		39.2	39.1						24.3	
Actuated g/C Ratio		0.37		0.52	0.52						0.32	
v/c Ratio		0.74		0.56	0.35						0.36	
Control Delay		23.1		17.4	12.0						10.6	
Queue Delay		0.0		0.0	0.0						0.0	
Total Delay		23.1		17.4	12.0						10.6	
LOS		C		B	B						B	
Approach Delay		23.1			14.2						10.6	
Approach LOS		C			B						B	
Queue Length 50th (m)		49.5		14.2	22.0						7.3	
Queue Length 95th (m)		m#82.1		25.6	37.3						9.6	
Internal Link Dist (m)		64.2			50.7			45.5			84.2	
Turn Bay Length (m)				15.0								
Base Capacity (vph)		504		349	819						1203	
Starvation Cap Reductn		0		0	0						0	
Spillback Cap Reductn		0		0	0						0	
Storage Cap Reductn		0		0	0						0	
Reduced v/c Ratio		0.74		0.56	0.35						0.36	

Intersection Summary	
Cycle Length: 75	
Actuated Cycle Length: 75	
Offset: 22 (29%), Referenced to phase 2:EBT and 6:WBTL, Start of Green	
Natural Cycle: 65	
Control Type: Actuated-Coordinated	

Lanes, Volumes, Timings
4: O'Connor Street & Laurier Avenue West

2033 Future Background
PM Peak Hour

Lane Group	Ø1	Ø3
Lane Configurations		
Traffic Volume (vph)		
Future Volume (vph)		
Satd. Flow (prot)		
Fit Permitted		
Satd. Flow (perm)		
Satd. Flow (RTOR)		
Lane Group Flow (vph)		
Turn Type		
Protected Phases	1	3
Permitted Phases		
Detector Phase		
Switch Phase		
Minimum Initial (s)	1.0	1.0
Minimum Split (s)	5.0	5.0
Total Split (s)	5.0	5.0
Total Split (%)	7%	7%
Yellow Time (s)	2.0	2.0
All-Red Time (s)	0.0	0.0
Lost Time Adjust (s)		
Total Lost Time (s)		
Lead/Lag	Lag	Lead
Lead-Lag Optimize?	Yes	Yes
Recall Mode	None	None
Act Effct Green (s)		
Actuated g/C Ratio		
v/c Ratio		
Control Delay		
Queue Delay		
Total Delay		
LOS		
Approach Delay		
Approach LOS		
Queue Length 50th (m)		
Queue Length 95th (m)		
Internal Link Dist (m)		
Turn Bay Length (m)		
Base Capacity (vph)		
Starvation Cap Reductn		
Spillback Cap Reductn		
Storage Cap Reductn		
Reduced v/c Ratio		

Intersection Summary	
Cycle Length: 75	
Actuated Cycle Length: 75	
Offset: 22 (29%), Referenced to phase 2:EBT and 6:WBTL, Start of Green	
Natural Cycle: 65	
Control Type: Actuated-Coordinated	

Lanes, Volumes, Timings
4: O'Connor Street & Laurier Avenue West

2033 Future Background
PM Peak Hour

Maximum v/c Ratio: 0.74
 Intersection Signal Delay: 15.6 Intersection LOS: B
 Intersection Capacity Utilization 66.5% ICU Level of Service C
 Analysis Period (min) 15
 # 95th percentile volume exceeds capacity, queue may be longer.
 Queue shown is maximum after two cycles.
 m Volume for 95th percentile queue is metered by upstream signal.

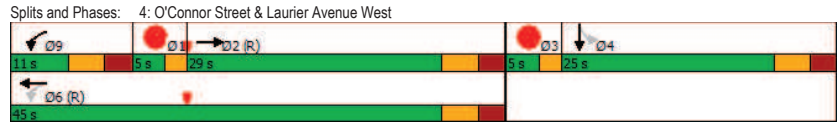

HCM 2010 TWSC
5: Laurier Avenue West & Site Access #1

2033 Future Background
PM Peak Hour

Intersection						
Int Delay, s/veh	3.6					
Movement	EBL	EBT	WBT	WBR	SBL	SBR
Lane Configurations		↔	↔		↔	↔
Traffic Vol, veh/h	3	339	316	4	39	88
Future Vol, veh/h	3	339	316	4	39	88
Conflicting Peds, #/hr	198	0	0	198	10	10
Sign Control	Free	Free	Free	Free	Stop	Stop
RT Channelized	-	None	-	None	-	None
Storage Length	-	-	-	-	0	-
Veh in Median Storage, #	-	0	0	-	0	-
Grade, %	-	0	0	-	0	-
Peak Hour Factor	100	100	100	100	100	100
Heavy Vehicles, %	2	2	2	2	2	2
Mvmt Flow	3	339	316	4	39	88
Major/Minor	Major1	Major2	Minor2			
Conflicting Flow All	518	0	0	871	526	
Stage 1	-	-	-	516	-	
Stage 2	-	-	-	355	-	
Critical Hdwy	4.12	-	-	6.42	6.22	
Critical Hdwy Stg 1	-	-	-	5.42	-	
Critical Hdwy Stg 2	-	-	-	5.42	-	
Follow-up Hdwy	2,218	-	-	3,518	3,318	
Pot Cap-1 Maneuver	1048	-	-	322	552	
Stage 1	-	-	-	599	-	
Stage 2	-	-	-	710	-	
Platoon blocked, %	-	-	-	-	-	
Mov Cap-1 Maneuver	855	-	-	213	446	
Mov Cap-2 Maneuver	-	-	-	213	-	
Stage 1	-	-	-	487	-	
Stage 2	-	-	-	579	-	
Approach	EB	WB	SB			
HCM Control Delay, s	0.1	0	22.2			
HCM LOS			C			
Minor Lane/Major Mvmt	EBL	EBT	WBT	WBR	SBLn1	
Capacity (veh/h)	855	-	-	-	334	
HCM Lane V/C Ratio	0.004	-	-	-	0.38	
HCM Control Delay (s)	9.2	0	-	-	22.2	
HCM Lane LOS	A	A	-	-	C	
HCM 95th %tile Q(veh)	0	-	-	-	1.7	

Appendix J

Synchro Intersection Worksheets –2028 Future Total Conditions

Lanes, Volumes, Timings

2028 Future Total

1: Bank Street & Slater Street /Slater Street

AM Peak Hour



Lane Group	EBL	EBT	EBR	WBL	WBT	WBR	NBL	NBT	NBR	SBL	SBT	SBR
Lane Configurations		↕↕	↕					↕			↕	
Traffic Volume (vph)	22	855	90	0	0	0	0	208	23	14	230	0
Future Volume (vph)	22	855	90	0	0	0	0	208	23	14	230	0
Satd. Flow (prot)	0	2785	1335	0	0	0	0	1412	0	0	1566	0
Fit Permitted		0.999						9			0.979	
Satd. Flow (perm)	0	2772	876	0	0	0	0	1412	0	0	1518	0
Satd. Flow (RTOR)			65									
Lane Group Flow (vph)	0	877	90	0	0	0	0	231	0	0	244	0
Turn Type	pm+pt	NA	Perm					NA	Perm	NA		
Protected Phases	5	2						4			8	
Permitted Phases	2		2							8		
Detector Phase	5	2	2					4		8	8	
Switch Phase												
Minimum Initial (s)	5.0	10.0	10.0					10.0	10.0	10.0		
Minimum Split (s)	10.0	24.0	24.0					35.0	35.0	35.0		
Total Split (s)	12.0	40.0	40.0					35.0	35.0	35.0		
Total Split (%)	16.0%	53.3%	53.3%					46.7%	46.7%	46.7%		
Yellow Time (s)	3.3	3.3	3.3					3.3	3.3	3.3		
All-Red Time (s)	1.7	1.7	1.7					2.2	2.2	2.2		
Lost Time Adjust (s)		0.0	0.0					0.0	0.0	0.0		
Total Lost Time (s)		5.0	5.0					5.5		5.5		
Lead/Lag	Lead										Lag	
Lead-Lag Optimize?	Yes										Yes	
Recall Mode	Max	C-Max	C-Max					Max	Max	Max		
Act Effct Green (s)		35.0	35.0					29.5		29.5		
Actuated g/C Ratio		0.47	0.47					0.39		0.39		
v/c Ratio		0.68	0.20					0.41		0.41		
Control Delay		18.9	6.2					12.0		19.1		
Queue Delay		0.0	0.0					0.0		0.0		
Total Delay		18.9	6.2					12.0		19.1		
LOS		B	A					B		B		
Approach Delay		17.7						12.0		19.1		
Approach LOS		B						B		B		
Queue Length 50th (m)		48.3	1.9					8.5		24.3		
Queue Length 95th (m)		68.1	9.3					24.5		42.2		
Internal Link Dist (m)		64.9				69.8		81.5		43.1		
Turn Bay Length (m)			65.0									
Base Capacity (vph)		1294	443					560		597		
Starvation Cap Reductn		0	0					0		0		
Spillback Cap Reductn		0	0					0		0		
Storage Cap Reductn		0	0					0		0		
Reduced v/c Ratio		0.68	0.20					0.41		0.41		

Intersection Summary

Cycle Length: 75
Actuated Cycle Length: 75
Offset: 48 (64%), Referenced to phase 2:EBTL and 6:Hold, Start of Green
Natural Cycle: 60
Control Type: Actuated-Coordinated

Lanes, Volumes, Timings

2028 Future Total

1: Bank Street & Slater Street /Slater Street

AM Peak Hour

Lane Group	Ø6
Lane Configurations	
Traffic Volume (vph)	
Future Volume (vph)	
Satd. Flow (prot)	
Fit Permitted	
Satd. Flow (perm)	
Satd. Flow (RTOR)	
Lane Group Flow (vph)	
Turn Type	
Protected Phases	6
Permitted Phases	
Detector Phase	
Switch Phase	
Minimum Initial (s)	1.0
Minimum Split (s)	3.0
Total Split (s)	28.0
Total Split (%)	37%
Yellow Time (s)	2.0
All-Red Time (s)	0.0
Lost Time Adjust (s)	
Total Lost Time (s)	
Lead/Lag	Lag
Lead-Lag Optimize?	Yes
Recall Mode	C-Max
Act Effct Green (s)	
Actuated g/C Ratio	
v/c Ratio	
Control Delay	
Queue Delay	
Total Delay	
LOS	
Approach Delay	
Approach LOS	
Queue Length 50th (m)	
Queue Length 95th (m)	
Internal Link Dist (m)	
Turn Bay Length (m)	
Base Capacity (vph)	
Starvation Cap Reductn	
Spillback Cap Reductn	
Storage Cap Reductn	
Reduced v/c Ratio	

Intersection Summary

Cycle Length: 75
Actuated Cycle Length: 75
Offset: 48 (64%), Referenced to phase 2:EBTL and 6:Hold, Start of Green
Natural Cycle: 60
Control Type: Actuated-Coordinated

Lanes, Volumes, Timings
1: Bank Street & Slater Street /Slater Street

2028 Future Total
AM Peak Hour

Maximum v/c Ratio: 0.68	Intersection LOS: B
Intersection Signal Delay: 17.0	ICU Level of Service C
Intersection Capacity Utilization 68.2%	
Analysis Period (min) 15	

Splits and Phases: 1: Bank Street & Slater Street /Slater Street

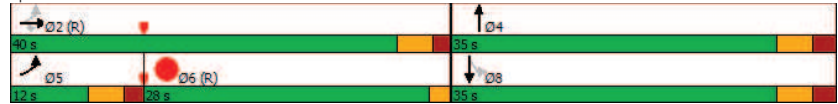

Lanes, Volumes, Timings
2: O'Connor Street & Slater Street

2028 Future Total
AM Peak Hour

Lane Group	EBL	EBT	EBR	WBL	WBT	WBR	NBL	NBT	NBR	SBL	SBT	SBR
Lane Configurations		↑↑	↑							↓	↓↑↑	
Traffic Volume (vph)	0	674	55	0	0	0	0	0	0	119	236	0
Future Volume (vph)	0	674	55	0	0	0	0	0	0	119	236	0
Satd. Flow (prot)	0	2767	1297	0	0	0	0	0	0	1463	4165	0
Fit Permitted										0.950		
Satd. Flow (perm)	0	2767	1035	0	0	0	0	0	0	941	4165	0
Satd. Flow (RTOR)										57		
Lane Group Flow (vph)	0	674	55	0	0	0	0	0	0	119	236	0
Turn Type		NA	Perm							Perm	NA	
Protected Phases		4									6	
Permitted Phases			4									6
Detector Phase		4	4							6	6	
Switch Phase												
Minimum Initial (s)		10.0	10.0							10.0	10.0	
Minimum Split (s)		30.5	30.5							22.5	22.5	
Total Split (s)		41.0	41.0							34.0	34.0	
Total Split (%)		54.7%	54.7%							45.3%	45.3%	
Yellow Time (s)		3.3	3.3							3.3	3.3	
All-Red Time (s)		2.2	2.2							2.2	2.2	
Lost Time Adjust (s)		0.0	0.0							0.0	0.0	
Total Lost Time (s)		5.5	5.5							5.5	5.5	
Lead/Lag												
Lead-Lag Optimize?												
Recall Mode		C-Max	C-Max							Max	Max	
Act Effct Green (s)		35.5	35.5							28.5	28.5	
Actuated g/C Ratio		0.47	0.47							0.38	0.38	
v/c Ratio		0.51	0.11							0.30	0.15	
Control Delay		2.5	1.7							11.6	15.6	
Queue Delay		0.0	0.0							0.0	0.0	
Total Delay		2.5	1.7							11.6	15.6	
LOS		A	A							B	B	
Approach Delay		2.4									14.3	
Approach LOS		A									B	
Queue Length 50th (m)		2.8	0.4							5.7	7.8	
Queue Length 95th (m)		3.6	m0.6							17.1	12.7	
Internal Link Dist (m)		63.6				58.3		84.2			37.7	
Turn Bay Length (m)			30.0									
Base Capacity (vph)		1309	489							392	1582	
Starvation Cap Reductn		0	0							0	0	
Spillback Cap Reductn		0	0							0	0	
Storage Cap Reductn		0	0							0	0	
Reduced v/c Ratio		0.51	0.11							0.30	0.15	

Intersection Summary

Cycle Length: 75
Actuated Cycle Length: 75
Offset: 48 (64%), Referenced to phase 4:EBT, Start of Green
Natural Cycle: 55
Control Type: Actuated-Coordinated

Lanes, Volumes, Timings
2: O'Connor Street & Slater Street

2028 Future Total
AM Peak Hour

Maximum v/c Ratio: 0.51	Intersection LOS: A
Intersection Signal Delay: 6.3	ICU Level of Service A
Intersection Capacity Utilization 45.2%	
Analysis Period (min) 15	

m Volume for 95th percentile queue is metered by upstream signal.

Splits and Phases: 2: O'Connor Street & Slater Street

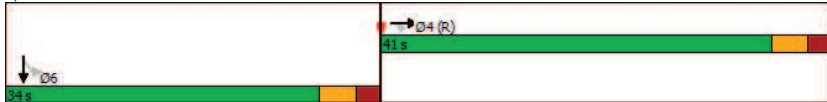

Lanes, Volumes, Timings
3: Bank Street & Laurier Avenue West

2028 Future Total
AM Peak Hour

Lane Group	EBL	EBT	EBR	WBL	WBT	WBR	NBL	NBT	NBR	SBL	SBT	SBR
Lane Configurations		↕	↕		↕			↕	↕		↕	↕
Traffic Volume (vph)	2	250	51	0	249	42	1	183	115	12	253	58
Future Volume (vph)	2	250	51	0	249	42	1	183	115	12	253	58
Satd. Flow (prot)	0	1565	1335	0	1350	0	0	1382	1335	0	1484	1335
Fit Permitted		0.998						0.999			0.987	
Satd. Flow (perm)	0	1558	498	0	1350	0	0	1377	479	0	1435	435
Satd. Flow (RTOR)												
Lane Group Flow (vph)	0	252	51	0	291	0	0	184	115	0	265	58
Turn Type	Perm	NA	Perm	NA	Perm	NA	Perm	NA	Perm	Perm	NA	Perm
Protected Phases			2		6			8			4	
Permitted Phases	2		2				8		8	4		4
Detector Phase	2	2	2		6		8	8	8	4	4	4
Switch Phase												
Minimum Initial (s)	10.0	10.0	10.0		10.0		10.0	10.0	10.0	10.0	10.0	10.0
Minimum Split (s)	23.9	23.9	23.9		23.9		23.6	23.6	23.6	23.6	23.6	23.6
Total Split (s)	27.0	27.0	27.0		27.0		38.0	38.0	38.0	38.0	38.0	38.0
Total Split (%)	36.0%	36.0%	36.0%		36.0%		50.7%	50.7%	50.7%	50.7%	50.7%	50.7%
Yellow Time (s)	3.3	3.3	3.3		3.3		3.3	3.3	3.3	3.3	3.3	3.3
All-Red Time (s)	2.6	2.6	2.6		2.6		2.3	2.3	2.3	2.3	2.3	2.3
Lost Time Adjust (s)		0.0	0.0		0.0		0.0	0.0	0.0	0.0	0.0	0.0
Total Lost Time (s)		5.9	5.9		5.9		5.6	5.6	5.6	5.6	5.6	5.6
Lead/Lag	Lag	Lag	Lag		Lag		Lag	Lag	Lag	Lag	Lag	Lag
Lead-Lag Optimize?	Yes	Yes	Yes		Yes		Yes	Yes	Yes	Yes	Yes	Yes
Recall Mode	C-Max	C-Max	C-Max		C-Max		Max	Max	Max	Max	Max	Max
Act Effct Green (s)	26.1	26.1	26.1		26.1		37.4	37.4	37.4	37.4	37.4	37.4
Actuated g/C Ratio	0.35	0.35			0.35		0.50	0.50		0.50	0.50	0.50
v/c Ratio	0.46	0.29			0.62		0.27	0.48		0.37	0.27	
Control Delay		22.5	23.5		40.6		12.2	21.0		8.1	9.7	
Queue Delay		0.0	0.0		0.0		0.0	0.0		0.0	0.0	
Total Delay		22.5	23.5		40.6		12.2	21.0		8.1	9.7	
LOS		C	C		D		B	C		A	A	
Approach Delay		22.7			40.6		15.6			8.4		
Approach LOS		C			D		B			A		
Queue Length 50th (m)		27.2	5.2		40.5		14.2	10.1		10.2	2.2	
Queue Length 95th (m)		47.1	14.2		64.5		26.1	25.7		18.6	6.0	
Internal Link Dist (m)		75.4			68.9		45.4			81.5		
Turn Bay Length (m)			45.0								10.0	
Base Capacity (vph)		542	173		469		686	238		715	216	
Starvation Cap Reductn		0	0		0		0	0		0	0	
Spillback Cap Reductn		0	0		0		0	0		0	0	
Storage Cap Reductn		0	0		0		0	0		0	0	
Reduced v/c Ratio		0.46	0.29		0.62		0.27	0.48		0.37	0.27	

Intersection Summary												
Cycle Length: 75												
Actuated Cycle Length: 75												
Offset: 40 (53%), Referenced to phase 2:EBTL and 6:WBT, Start of Green												
Natural Cycle: 55												
Control Type: Actuated-Coordinated												

Lanes, Volumes, Timings
3: Bank Street & Laurier Avenue West

2028 Future Total
AM Peak Hour

Lane Group	Ø1	Ø3	Ø5	Ø7
Lane Configurations				
Traffic Volume (vph)				
Future Volume (vph)				
Satd. Flow (prot)				
Fit Permitted				
Satd. Flow (perm)				
Satd. Flow (RTOR)				
Lane Group Flow (vph)				
Turn Type				
Protected Phases	1	3	5	7
Permitted Phases				
Detector Phase				
Switch Phase				
Minimum Initial (s)	1.0	1.0	1.0	1.0
Minimum Split (s)	3.0	3.0	3.0	3.0
Total Split (s)	5.0	5.0	5.0	5.0
Total Split (%)	7%	7%	7%	7%
Yellow Time (s)	2.0	2.0	2.0	2.0
All-Red Time (s)	0.0	0.0	0.0	0.0
Lost Time Adjust (s)				
Total Lost Time (s)				
Lead/Lag	Lead	Lead	Lead	Lead
Lead-Lag Optimize?	Yes	Yes	Yes	Yes
Recall Mode	None	None	None	None
Act Effct Green (s)				
Actuated g/C Ratio				
v/c Ratio				
Control Delay				
Queue Delay				
Total Delay				
LOS				
Approach Delay				
Approach LOS				
Queue Length 50th (m)				
Queue Length 95th (m)				
Internal Link Dist (m)				
Turn Bay Length (m)				
Base Capacity (vph)				
Starvation Cap Reductn				
Spillback Cap Reductn				
Storage Cap Reductn				
Reduced v/c Ratio				
Intersection Summary				

Lanes, Volumes, Timings
3: Bank Street & Laurier Avenue West

2028 Future Total
AM Peak Hour

Maximum v/c Ratio: 0.62	
Intersection Signal Delay: 21.4	Intersection LOS: C
Intersection Capacity Utilization 63.3%	ICU Level of Service B
Analysis Period (min) 15	

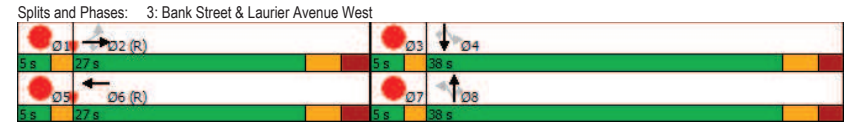

Lanes, Volumes, Timings
4: O'Connor Street & Laurier Avenue West

2028 Future Total
AM Peak Hour

Lane Group	EBL	EBT	EBR	WBL	WBT	WBR	NBL	NBT	NBR	SBL	SBT	SBR
Lane Configurations		↔	↔	↔	↔					↔↔↔		
Traffic Volume (vph)	0	227	155	146	261	0	0	0	0	28	229	22
Future Volume (vph)	0	227	155	146	261	0	0	0	0	28	229	22
Satd. Flow (prot)	0	1262	0	1492	1511	0	0	0	0	0	3897	0
Fit Permitted				0.337							0.995	
Satd. Flow (perm)	0	1262	0	529	1511	0	0	0	0	0	3665	0
Satd. Flow (RTOR)												
Lane Group Flow (vph)	0	382	0	146	261	0	0	0	0	0	279	0
Turn Type		NA		pm+pt	NA					Perm	NA	
Protected Phases		2		9	6							4
Permitted Phases				6							4	
Detector Phase		2		9	6						4	4
Switch Phase												
Minimum Initial (s)		10.0		5.0	10.0					10.0	10.0	
Minimum Split (s)		16.9		10.8	16.9					16.7	16.7	
Total Split (s)		29.0		11.0	45.0					25.0	25.0	
Total Split (%)		38.7%		14.7%	60.0%					33.3%	33.3%	
Yellow Time (s)		3.3		3.3	3.3					3.3	3.3	
All-Red Time (s)		2.6		2.5	2.6					2.4	2.4	
Lost Time Adjust (s)		0.0		0.0	0.0						0.0	
Total Lost Time (s)		5.9		5.8	5.9						5.7	
Lead/Lag				Lead						Lag	Lag	
Lead-Lag Optimize?				Yes						Yes	Yes	
Recall Mode		C-Max		Max	C-Max					Max	Max	
Act Effct Green (s)		28.1		39.2	39.1						24.3	
Actuated g/C Ratio		0.37		0.52	0.52						0.32	
v/c Ratio		0.81		0.43	0.33						0.24	
Control Delay		34.3		13.8	11.9						9.4	
Queue Delay		0.0		0.0	0.0						0.0	
Total Delay		34.3		13.8	11.9						9.4	
LOS		C		B	B						A	
Approach Delay		34.3			12.6						9.4	
Approach LOS		C			B						A	
Queue Length 50th (m)		51.4		10.2	19.9						4.5	
Queue Length 95th (m)		#94.1		19.5	34.5						6.8	
Internal Link Dist (m)		29.1			50.7			45.5			84.2	
Turn Bay Length (m)				15.0								
Base Capacity (vph)		472		343	787						1187	
Starvation Cap Reductn		0		0	0						0	
Spillback Cap Reductn		0		0	0						0	
Storage Cap Reductn		0		0	0						0	
Reduced v/c Ratio		0.81		0.43	0.33						0.24	

Intersection Summary	
Cycle Length: 75	
Actuated Cycle Length: 75	
Offset: 63 (84%), Referenced to phase 2:EBT and 6:WBTL, Start of Green	
Natural Cycle: 65	
Control Type: Actuated-Coordinated	

Lanes, Volumes, Timings
4: O'Connor Street & Laurier Avenue West

2028 Future Total
AM Peak Hour

Lane Group	Ø1	Ø3
Lane Configurations		
Traffic Volume (vph)		
Future Volume (vph)		
Satd. Flow (prot)		
Fit Permitted		
Satd. Flow (perm)		
Satd. Flow (RTOR)		
Lane Group Flow (vph)		
Turn Type		
Protected Phases	1	3
Permitted Phases		
Detector Phase		
Switch Phase		
Minimum Initial (s)	1.0	1.0
Minimum Split (s)	5.0	5.0
Total Split (s)	5.0	5.0
Total Split (%)	7%	7%
Yellow Time (s)	2.0	2.0
All-Red Time (s)	0.0	0.0
Lost Time Adjust (s)		
Total Lost Time (s)		
Lead/Lag	Lag	Lead
Lead-Lag Optimize?	Yes	Yes
Recall Mode	None	None
Act Effct Green (s)		
Actuated g/C Ratio		
v/c Ratio		
Control Delay		
Queue Delay		
Total Delay		
LOS		
Approach Delay		
Approach LOS		
Queue Length 50th (m)		
Queue Length 95th (m)		
Internal Link Dist (m)		
Turn Bay Length (m)		
Base Capacity (vph)		
Starvation Cap Reductn		
Spillback Cap Reductn		
Storage Cap Reductn		
Reduced v/c Ratio		

Intersection Summary	
Cycle Length: 75	
Actuated Cycle Length: 75	
Offset: 63 (84%), Referenced to phase 2:EBT and 6:WBTL, Start of Green	
Natural Cycle: 65	
Control Type: Actuated-Coordinated	

Lanes, Volumes, Timings
4: O'Connor Street & Laurier Avenue West

2028 Future Total
AM Peak Hour

Maximum v/c Ratio: 0.81	Intersection LOS: B
Intersection Signal Delay: 19.5	ICU Level of Service C
Intersection Capacity Utilization 64.3%	
Analysis Period (min) 15	
# 95th percentile volume exceeds capacity, queue may be longer.	
Queue shown is maximum after two cycles.	

Splits and Phases: 4: O'Connor Street & Laurier Avenue West



Lanes, Volumes, Timings
5: Laurier Avenue West & Site Access

2028 Future Total
AM Peak Hour



Lane Group	EBL	EBT	WBT	WBR	SBL	SBR
Lane Configurations		↕	↕			
Traffic Volume (vph)	15	466	353	8	0	0
Future Volume (vph)	15	466	353	8	0	0
Satd. Flow (prot)	0	1567	1566	0	0	0
Fit Permitted		0.998				
Satd. Flow (perm)	0	1567	1566	0	0	0
Lane Group Flow (vph)	0	481	361	0	0	0
Sign Control		Free	Free		Free	

Intersection Summary

Control Type: Unsignalized	
Intersection Capacity Utilization 55.8%	ICU Level of Service B
Analysis Period (min) 15	

HCM 2010 TWSC
6: Site Access & Slater Street

2028 Future Total
AM Peak Hour

Intersection						
Int Delay, s/veh	0					
Movement	EBT	EBR	WBL	WBT	NBL	NBR
Lane Configurations	↑↑					↑
Traffic Vol, veh/h	726	0	0	0	0	3
Future Vol, veh/h	726	0	0	0	0	3
Conflicting Peds, #/hr	0	214	214	0	0	0
Sign Control	Free	Free	Free	Free	Stop	Stop
RT Channelized	-	None	-	None	-	None
Storage Length	-	-	-	-	-	0
Veh in Median Storage, #	0	-	-	-	0	-
Grade, %	0	-	-	0	0	-
Peak Hour Factor	100	100	100	100	100	100
Heavy Vehicles, %	2	2	2	2	2	2
Mvmt Flow	726	0	0	0	0	3
Major/Minor	Major1		Minor1			
Conflicting Flow All	0	-	-	-	-	363
Stage 1	-	-	-	-	-	-
Stage 2	-	-	-	-	-	-
Critical Hdwy	-	-	-	-	-	6.94
Critical Hdwy Stg 1	-	-	-	-	-	-
Critical Hdwy Stg 2	-	-	-	-	-	-
Follow-up Hdwy	-	-	-	-	-	3.32
Pot Cap-1 Maneuver	-	0	0	0	0	634
Stage 1	-	0	0	0	0	-
Stage 2	-	0	0	0	0	-
Platoon blocked, %	-	-	-	-	-	-
Mov Cap-1 Maneuver	-	-	-	-	-	634
Mov Cap-2 Maneuver	-	-	-	-	-	-
Stage 1	-	-	-	-	-	-
Stage 2	-	-	-	-	-	-
Approach	EB		NB			
HCM Control Delay, s	0		10.7			
HCM LOS			B			
Minor Lane/Major Mvmt	NBLn1	EBT				
Capacity (veh/h)	634	-				
HCM Lane V/C Ratio	0.005	-				
HCM Control Delay (s)	10.7	-				
HCM Lane LOS	B	-				
HCM 95th %tile Q(veh)	0	-				

HCM 2010 TWSC
7: Laurier Avenue West & Site Access #3

2028 Future Total
AM Peak Hour

Intersection						
Int Delay, s/veh	0.9					
Movement	EBL	EBT	WBT	WBR	SBL	SBR
Lane Configurations		↑	↑		↑	↑
Traffic Vol, veh/h	8	458	349	6	17	12
Future Vol, veh/h	8	458	349	6	17	12
Conflicting Peds, #/hr	198	0	0	198	0	0
Sign Control	Free	Free	Free	Free	Stop	Stop
RT Channelized	-	None	-	None	-	None
Storage Length	-	-	-	-	0	-
Veh in Median Storage, #	-	0	0	-	0	-
Grade, %	-	0	0	-	0	-
Peak Hour Factor	100	100	100	100	100	100
Heavy Vehicles, %	2	2	2	2	2	2
Mvmt Flow	8	458	349	6	17	12
Major/Minor	Major1	Major2	Minor2			
Conflicting Flow All	553	0	-	0	1024	550
Stage 1	-	-	-	-	550	-
Stage 2	-	-	-	-	474	-
Critical Hdwy	4.12	-	-	-	6.42	6.22
Critical Hdwy Stg 1	-	-	-	-	5.42	-
Critical Hdwy Stg 2	-	-	-	-	5.42	-
Follow-up Hdwy	2,218	-	-	-	3,518	3,318
Pot Cap-1 Maneuver	1017	-	-	-	261	535
Stage 1	-	-	-	-	578	-
Stage 2	-	-	-	-	626	-
Platoon blocked, %	-	-	-	-	-	-
Mov Cap-1 Maneuver	829	-	-	-	171	436
Mov Cap-2 Maneuver	-	-	-	-	171	-
Stage 1	-	-	-	-	465	-
Stage 2	-	-	-	-	511	-
Approach	EB		WB		SB	
HCM Control Delay, s	0.2		0		23.1	
HCM LOS					C	
Minor Lane/Major Mvmt	EBL	EBT	WBT	WBR	SBLn1	SBRn1
Capacity (veh/h)	829	-	-	-	-	228
HCM Lane V/C Ratio	0.01	-	-	-	-	0.127
HCM Control Delay (s)	9.4	0	-	-	-	23.1
HCM Lane LOS	A	A	-	-	-	C
HCM 95th %tile Q(veh)	0	-	-	-	-	0.4

Lanes, Volumes, Timings

1: Bank Street & Slater Street /Slater Street

2028 Future Total

PM Peak Hour

Lane Group	EBL	EBT	EBR	WBL	WBT	WBR	NBL	NBT	NBR	SBL	SBT	SBR
Lane Configurations		↕↕	↕					↕			↕	
Traffic Volume (vph)	25	817	154	0	0	0	0	226	19	13	233	0
Future Volume (vph)	25	817	154	0	0	0	0	226	19	13	233	0
Satd. Flow (prot)	0	2908	1335	0	0	0	0	1445	0	0	1461	0
Fit Permitted		0.999									0.980	
Satd. Flow (perm)	0	2887	940	0	0	0	0	1445	0	0	1417	0
Satd. Flow (RTOR)			45					7				
Lane Group Flow (vph)	0	842	154	0	0	0	0	245	0	0	246	0
Turn Type	pm+pt	NA	Perm					NA	Perm	NA		
Protected Phases	5	2						4			8	
Permitted Phases	2		2							8		
Detector Phase	5	2	2					4		8	8	
Switch Phase												
Minimum Initial (s)	5.0	10.0	10.0					10.0	10.0	10.0		
Minimum Split (s)	10.0	24.0	24.0					35.0	35.0	35.0		
Total Split (s)	12.0	40.0	40.0					35.0	35.0	35.0		
Total Split (%)	16.0%	53.3%	53.3%					46.7%	46.7%	46.7%		
Yellow Time (s)	3.3	3.3	3.3					3.3	3.3	3.3		
All-Red Time (s)	1.7	1.7	1.7					2.2	2.2	2.2		
Lost Time Adjust (s)		0.0	0.0					0.0	0.0	0.0		
Total Lost Time (s)		5.0	5.0					5.5		5.5		
Lead/Lag	Lead										Lag	
Lead-Lag Optimize?	Yes										Yes	
Recall Mode	Max	C-Max	C-Max					Max	Max	Max		
Act Effct Green (s)		35.0	35.0					29.5		29.5		
Actuated g/C Ratio		0.47	0.47					0.39		0.39		
v/c Ratio		0.62	0.33					0.43		0.44		
Control Delay		17.6	11.2					11.7		19.9		
Queue Delay		0.0	0.0					0.0		0.0		
Total Delay		17.6	11.2					11.7		19.9		
LOS		B	B					B		B		
Approach Delay		16.6						11.7		19.9		
Approach LOS		B						B		B		
Queue Length 50th (m)		44.8	8.9					10.8		24.9		
Queue Length 95th (m)		62.7	21.4					17.4		43.8		
Internal Link Dist (m)		64.9			70.6			81.5		43.1		
Turn Bay Length (m)			65.0									
Base Capacity (vph)		1349	462					572		557		
Starvation Cap Reductn		0	0					0		0		
Spillback Cap Reductn		0	0					0		0		
Storage Cap Reductn		0	0					0		0		
Reduced v/c Ratio		0.62	0.33					0.43		0.44		

Intersection Summary

Cycle Length: 75

Actuated Cycle Length: 75

Offset: 20 (27%), Referenced to phase 2:EBTL and 6:Hold, Start of Green

Natural Cycle: 60

Control Type: Actuated-Coordinated

Lanes, Volumes, Timings

1: Bank Street & Slater Street /Slater Street

2028 Future Total

PM Peak Hour

Lane Group	Ø6
Lane Configurations	
Traffic Volume (vph)	
Future Volume (vph)	
Satd. Flow (prot)	
Fit Permitted	
Satd. Flow (perm)	
Satd. Flow (RTOR)	
Lane Group Flow (vph)	
Turn Type	
Protected Phases	6
Permitted Phases	
Detector Phase	
Switch Phase	
Minimum Initial (s)	1.0
Minimum Split (s)	3.0
Total Split (s)	28.0
Total Split (%)	37%
Yellow Time (s)	2.0
All-Red Time (s)	0.0
Lost Time Adjust (s)	
Total Lost Time (s)	
Lead/Lag	Lag
Lead-Lag Optimize?	Yes
Recall Mode	C-Max
Act Effct Green (s)	
Actuated g/C Ratio	
v/c Ratio	
Control Delay	
Queue Delay	
Total Delay	
LOS	
Approach Delay	
Approach LOS	
Queue Length 50th (m)	
Queue Length 95th (m)	
Internal Link Dist (m)	
Turn Bay Length (m)	
Base Capacity (vph)	
Starvation Cap Reductn	
Spillback Cap Reductn	
Storage Cap Reductn	
Reduced v/c Ratio	

Intersection Summary

Lanes, Volumes, Timings
1: Bank Street & Slater Street /Slater Street

2028 Future Total
PM Peak Hour

Maximum v/c Ratio: 0.62	Intersection LOS: B
Intersection Signal Delay: 16.3	ICU Level of Service C
Intersection Capacity Utilization 66.3%	
Analysis Period (min) 15	



Lanes, Volumes, Timings
2: O'Connor Street & Slater Street

2028 Future Total
PM Peak Hour

Lane Group	EBL	EBT	EBR	WBL	WBT	WBR	NBL	NBT	NBR	SBL	SBT	SBR
Lane Configurations		↑↑	↑							↓	↓↑↑	
Traffic Volume (vph)	0	815	61	0	0	0	0	0	0	105	361	0
Future Volume (vph)	0	815	61	0	0	0	0	0	0	105	361	0
Satd. Flow (prot)	0	2899	1322	0	0	0	0	0	0	1436	4288	0
Fit Permitted										0.950		
Satd. Flow (perm)	0	2899	1060	0	0	0	0	0	0	975	4288	0
Satd. Flow (RTOR)										55		
Lane Group Flow (vph)	0	815	61	0	0	0	0	0	0	105	361	0
Turn Type		NA	Perm							Perm	NA	
Protected Phases		4									6	
Permitted Phases			4									6
Detector Phase		4	4							6	6	
Switch Phase												
Minimum Initial (s)		10.0	10.0							10.0	10.0	
Minimum Split (s)		30.5	30.5							22.5	22.5	
Total Split (s)		45.0	45.0							30.0	30.0	
Total Split (%)		60.0%	60.0%							40.0%	40.0%	
Yellow Time (s)		3.3	3.3							3.3	3.3	
All-Red Time (s)		2.2	2.2							2.2	2.2	
Lost Time Adjust (s)		0.0	0.0							0.0	0.0	
Total Lost Time (s)		5.5	5.5							5.5	5.5	
Lead/Lag												
Lead-Lag Optimize?												
Recall Mode		C-Max	C-Max							Max	Max	
Act Effct Green (s)		39.5	39.5							24.5	24.5	
Actuated g/C Ratio		0.53	0.53							0.33	0.33	
v/c Ratio		0.53	0.11							0.30	0.26	
Control Delay		4.0	3.1							12.8	19.2	
Queue Delay		0.0	0.0							0.0	0.0	
Total Delay		4.0	3.1							12.8	19.2	
LOS		A	A							B	B	
Approach Delay		3.9									17.7	
Approach LOS		A									B	
Queue Length 50th (m)		7.0	1.0							5.0	13.5	
Queue Length 95th (m)		8.8	1.6							16.3	20.3	
Internal Link Dist (m)		62.8				58.3		84.2			37.7	
Turn Bay Length (m)			30.0									
Base Capacity (vph)		1526	558							355	1400	
Starvation Cap Reductn		0	0							0	0	
Spillback Cap Reductn		0	0							0	0	
Storage Cap Reductn		0	0							0	0	
Reduced v/c Ratio		0.53	0.11							0.30	0.26	

Intersection Summary	
Cycle Length:	75
Actuated Cycle Length:	75
Offset:	12 (16%), Referenced to phase 4:EBT, Start of Green
Natural Cycle:	55
Control Type:	Actuated-Coordinated

Lanes, Volumes, Timings
2: O'Connor Street & Slater Street

2028 Future Total
PM Peak Hour

Maximum v/c Ratio: 0.53	Intersection LOS: A
Intersection Signal Delay: 8.7	ICU Level of Service A
Intersection Capacity Utilization 49.8%	
Analysis Period (min) 15	

m Volume for 95th percentile queue is metered by upstream signal.

Splits and Phases: 2: O'Connor Street & Slater Street

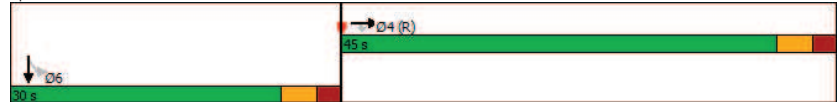

Lanes, Volumes, Timings
3: Bank Street & Laurier Avenue West

2028 Future Total
PM Peak Hour

Lane Group	EBL	EBT	EBR	WBL	WBT	WBR	NBL	NBT	NBR	SBL	SBT	SBR
Lane Configurations		↕	↕		↕			↕	↕		↕	↕
Traffic Volume (vph)	0	246	80	2	222	63	1	197	87	18	300	76
Future Volume (vph)	0	246	80	2	222	63	1	197	87	18	300	76
Satd. Flow (prot)	0	1571	1335	0	1326	0	0	1491	1335	0	1537	1335
Fit Permitted					0.998			0.999			0.980	
Satd. Flow (perm)	0	1571	471	0	1320	0	0	1486	223	0	1458	261
Satd. Flow (RTOR)												
Lane Group Flow (vph)	0	246	80	0	287	0	0	198	87	0	318	76
Turn Type		NA	Perm	Perm	NA		Perm	NA	Perm	Perm	NA	Perm
Protected Phases		2			6			8			4	
Permitted Phases	2		2	6			8		8	4		4
Detector Phase	2	2	2	6	6		8	8	8	4	4	4
Switch Phase												
Minimum Initial (s)	10.0	10.0	10.0	10.0	10.0		10.0	10.0	10.0	10.0	10.0	10.0
Minimum Split (s)	23.9	23.9	23.9	23.9	23.9		23.6	23.6	23.6	23.6	23.6	23.6
Total Split (s)	30.0	30.0	30.0	30.0	30.0		35.0	35.0	35.0	35.0	35.0	35.0
Total Split (%)	40.0%	40.0%	40.0%	40.0%	40.0%		46.7%	46.7%	46.7%	46.7%	46.7%	46.7%
Yellow Time (s)	3.3	3.3	3.3	3.3	3.3		3.3	3.3	3.3	3.3	3.3	3.3
All-Red Time (s)	2.6	2.6	2.6	2.6	2.6		2.3	2.3	2.3	2.3	2.3	2.3
Lost Time Adjust (s)		0.0	0.0		0.0			0.0	0.0		0.0	0.0
Total Lost Time (s)		5.9	5.9		5.9			5.6	5.6		5.6	5.6
Lead/Lag	Lag	Lag	Lag	Lag	Lag		Lag	Lag	Lag	Lag	Lag	Lag
Lead-Lag Optimize?	Yes	Yes	Yes	Yes	Yes		Yes	Yes	Yes	Yes	Yes	Yes
Recall Mode	C-Max	C-Max	C-Max	C-Max	C-Max		Max	Max	Max	Max	Max	Max
Act Effct Green (s)	29.1	29.1		29.1			34.4	34.4		34.4		34.4
Actuated g/C Ratio	0.39	0.39		0.39			0.46	0.46		0.46		0.46
v/c Ratio	0.40	0.44		0.56			0.29	0.85		0.48		0.64
Control Delay	19.2	26.4		15.8			14.2	82.6		12.3		38.1
Queue Delay	0.0	0.0		0.0			0.0	0.0		0.2		0.0
Total Delay	19.2	26.4		15.8			14.2	82.6		12.5		38.1
LOS	B	C		B			B	F		B		D
Approach Delay	21.0			15.8			35.0			17.5		
Approach LOS	C			B			D			B		
Queue Length 50th (m)	24.6	8.1		16.1			16.7	10.4		19.8		4.9
Queue Length 95th (m)	42.7	21.2		25.1			30.1	#36.9		31.8		#29.9
Internal Link Dist (m)	75.4			68.9			45.4			81.5		
Turn Bay Length (m)			45.0									10.0
Base Capacity (vph)		609	182		512		681	102		668		119
Starvation Cap Reductn	0	0		0			0	0		62		0
Spillback Cap Reductn	0	0		0			0	0		0		0
Storage Cap Reductn	0	0		0			0	0		0		0
Reduced v/c Ratio	0.40	0.44		0.56			0.29	0.85		0.52		0.64

Intersection Summary												
Cycle Length: 75												
Actuated Cycle Length: 75												
Offset: 11 (15%), Referenced to phase 2:EBTL and 6:WBTL, Start of Green												
Natural Cycle: 55												
Control Type: Actuated-Coordinated												

Lanes, Volumes, Timings
 3: Bank Street & Laurier Avenue West

2028 Future Total
 PM Peak Hour

Lane Group	Ø1	Ø3	Ø5	Ø7
Lane Configurations				
Traffic Volume (vph)				
Future Volume (vph)				
Satd. Flow (prot)				
Fit Permitted				
Satd. Flow (perm)				
Satd. Flow (RTOR)				
Lane Group Flow (vph)				
Turn Type				
Protected Phases	1	3	5	7
Permitted Phases				
Detector Phase				
Switch Phase				
Minimum Initial (s)	1.0	1.0	1.0	1.0
Minimum Split (s)	3.0	3.0	3.0	3.0
Total Split (s)	5.0	5.0	5.0	5.0
Total Split (%)	7%	7%	7%	7%
Yellow Time (s)	2.0	2.0	2.0	2.0
All-Red Time (s)	0.0	0.0	0.0	0.0
Lost Time Adjust (s)				
Total Lost Time (s)				
Lead/Lag	Lead	Lead	Lead	Lead
Lead-Lag Optimize?	Yes	Yes	Yes	Yes
Recall Mode	None	None	None	None
Act Effct Green (s)				
Actuated g/C Ratio				
v/c Ratio				
Control Delay				
Queue Delay				
Total Delay				
LOS				
Approach Delay				
Approach LOS				
Queue Length 50th (m)				
Queue Length 95th (m)				
Internal Link Dist (m)				
Turn Bay Length (m)				
Base Capacity (vph)				
Starvation Cap Reductn				
Spillback Cap Reductn				
Storage Cap Reductn				
Reduced v/c Ratio				
Intersection Summary				

Lanes, Volumes, Timings
 3: Bank Street & Laurier Avenue West

2028 Future Total
 PM Peak Hour

Maximum v/c Ratio: 0.85
Intersection Signal Delay: 21.8
Intersection Capacity Utilization 68.5%
Analysis Period (min) 15
95th percentile volume exceeds capacity, queue may be longer.
Queue shown is maximum after two cycles.

Splits and Phases: 3: Bank Street & Laurier Avenue West

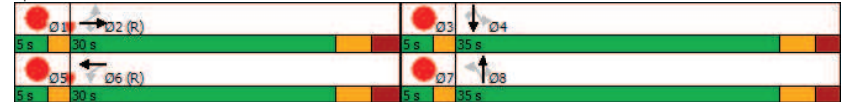

Lanes, Volumes, Timings
4: O'Connor Street & Laurier Avenue West

2028 Future Total
PM Peak Hour

Lane Group	EBL	EBT	EBR	WBL	WBT	WBR	NBL	NBT	NBR	SBL	SBT	SBR
Lane Configurations		↔	↔	↔	↔					↔↔↔		
Traffic Volume (vph)	0	247	97	196	294	0	0	0	0	55	348	32
Future Volume (vph)	0	247	97	196	294	0	0	0	0	55	348	32
Satd. Flow (prot)	0	1345	0	1492	1571	0	0	0	0	0	4013	0
Fit Permitted				0.375							0.994	
Satd. Flow (perm)	0	1345	0	589	1571	0	0	0	0	0	3709	0
Satd. Flow (RTOR)												
Lane Group Flow (vph)	0	344	0	196	294	0	0	0	0	0	435	0
Turn Type		NA		pm+pt	NA					Perm	NA	
Protected Phases		2		9	6							4
Permitted Phases				6							4	
Detector Phase		2		9	6						4	4
Switch Phase												
Minimum Initial (s)		10.0		5.0	10.0					10.0	10.0	
Minimum Split (s)		16.9		10.8	16.9					16.7	16.7	
Total Split (s)		29.0		11.0	45.0					25.0	25.0	
Total Split (%)		38.7%		14.7%	60.0%					33.3%	33.3%	
Yellow Time (s)		3.3		3.3	3.3					3.3	3.3	
All-Red Time (s)		2.6		2.5	2.6					2.4	2.4	
Lost Time Adjust (s)		0.0		0.0	0.0						0.0	
Total Lost Time (s)		5.9		5.8	5.9						5.7	
Lead/Lag				Lead						Lag	Lag	
Lead-Lag Optimize?				Yes						Yes	Yes	
Recall Mode		C-Max		Max	C-Max					Max	Max	
Act Effct Green (s)		28.1		39.2	39.1						24.3	
Actuated g/C Ratio		0.37		0.52	0.52						0.32	
v/c Ratio		0.68		0.53	0.36						0.36	
Control Delay		19.8		16.1	12.2						10.7	
Queue Delay		0.0		0.0	0.0						0.0	
Total Delay		19.8		16.1	12.2						10.7	
LOS		B		B	B						B	
Approach Delay		19.8			13.8						10.7	
Approach LOS		B			B						B	
Queue Length 50th (m)		18.6		14.2	22.8						7.4	
Queue Length 95th (m)		m69.0		25.6	38.6						9.9	
Internal Link Dist (m)		25.2			50.7			45.5			84.2	
Turn Bay Length (m)				15.0								
Base Capacity (vph)		503		370	819						1201	
Starvation Cap Reductn		0		0	0						0	
Spillback Cap Reductn		0		0	0						0	
Storage Cap Reductn		0		0	0						0	
Reduced v/c Ratio		0.68		0.53	0.36						0.36	

Intersection Summary	
Cycle Length: 75	
Actuated Cycle Length: 75	
Offset: 22 (29%), Referenced to phase 2:EBT and 6:WBTL, Start of Green	
Natural Cycle: 65	
Control Type: Actuated-Coordinated	

Lanes, Volumes, Timings
4: O'Connor Street & Laurier Avenue West

2028 Future Total
PM Peak Hour

Lane Group	Ø1	Ø3
Lane Configurations		
Traffic Volume (vph)		
Future Volume (vph)		
Satd. Flow (prot)		
Fit Permitted		
Satd. Flow (perm)		
Satd. Flow (RTOR)		
Lane Group Flow (vph)		
Turn Type		
Protected Phases	1	3
Permitted Phases		
Detector Phase		
Switch Phase		
Minimum Initial (s)	1.0	1.0
Minimum Split (s)	5.0	5.0
Total Split (s)	5.0	5.0
Total Split (%)	7%	7%
Yellow Time (s)	2.0	2.0
All-Red Time (s)	0.0	0.0
Lost Time Adjust (s)		
Total Lost Time (s)		
Lead/Lag	Lag	Lead
Lead-Lag Optimize?	Yes	Yes
Recall Mode	None	None
Act Effct Green (s)		
Actuated g/C Ratio		
v/c Ratio		
Control Delay		
Queue Delay		
Total Delay		
LOS		
Approach Delay		
Approach LOS		
Queue Length 50th (m)		
Queue Length 95th (m)		
Internal Link Dist (m)		
Turn Bay Length (m)		
Base Capacity (vph)		
Starvation Cap Reductn		
Spillback Cap Reductn		
Storage Cap Reductn		
Reduced v/c Ratio		

Intersection Summary	
Cycle Length: 75	
Actuated Cycle Length: 75	
Offset: 22 (29%), Referenced to phase 2:EBT and 6:WBTL, Start of Green	
Natural Cycle: 65	
Control Type: Actuated-Coordinated	

Lanes, Volumes, Timings
4: O'Connor Street & Laurier Avenue West

2028 Future Total
 PM Peak Hour

Maximum v/c Ratio: 0.68	Intersection LOS: B
Intersection Signal Delay: 14.4	ICU Level of Service C
Intersection Capacity Utilization 64.8%	
Analysis Period (min) 15	

m Volume for 95th percentile queue is metered by upstream signal.

Splits and Phases: 4: O'Connor Street & Laurier Avenue West



Lanes, Volumes, Timings
5: Laurier Avenue West & Site Access

2028 Future Total
 PM Peak Hour



Lane Group	EBL	EBT	WBT	WBR	SBL	SBR
Lane Configurations		↕	↕			
Traffic Volume (vph)	4	350	323	5	0	0
Future Volume (vph)	4	350	323	5	0	0
Satd. Flow (prot)	0	1569	1567	0	0	0
Fit Permitted		0.999				
Satd. Flow (perm)	0	1569	1567	0	0	0
Lane Group Flow (vph)	0	354	328	0	0	0
Sign Control		Free	Free		Free	

Intersection Summary						
Control Type: Unsignalized						
Intersection Capacity Utilization 38.2%				ICU Level of Service A		
Analysis Period (min) 15						

HCM 2010 TWSC
6: Site Access & Slater Street

2028 Future Total
PM Peak Hour

Intersection						
Int Delay, s/veh	0.4					
Movement	EBT	EBR	WBL	WBT	NBL	NBR
Lane Configurations	↑↑					↑
Traffic Vol, veh/h	848	0	0	0	0	28
Future Vol, veh/h	848	0	0	0	0	28
Conflicting Peds, #/hr	0	208	208	0	0	0
Sign Control	Free	Free	Free	Free	Stop	Stop
RT Channelized	-	None	-	None	-	None
Storage Length	-	-	-	-	-	0
Veh in Median Storage, #	0	-	-	-	0	-
Grade, %	0	-	-	0	0	-
Peak Hour Factor	100	100	100	100	100	100
Heavy Vehicles, %	2	2	2	2	2	2
Mvmt Flow	848	0	0	0	0	28

Major/Minor	Major1	Minor1
Conflicting Flow All	0	- 424
Stage 1	-	-
Stage 2	-	-
Critical Hdwy	-	- 6.94
Critical Hdwy Stg 1	-	-
Critical Hdwy Stg 2	-	-
Follow-up Hdwy	-	- 3.32
Pot Cap-1 Maneuver	- 0	0 579
Stage 1	- 0	0 -
Stage 2	- 0	0 -
Platoon blocked, %	-	-
Mov Cap-1 Maneuver	-	- 579
Mov Cap-2 Maneuver	-	-
Stage 1	-	-
Stage 2	-	-

Approach	EB	NB
HCM Control Delay, s	0	11.5
HCM LOS		B

Minor Lane/Major Mvmt	NBLn1	EBT
Capacity (veh/h)	579	-
HCM Lane V/C Ratio	0.048	-
HCM Control Delay (s)	11.5	-
HCM Lane LOS	B	-
HCM 95th %tile Q(veh)	0.2	-

HCM 2010 TWSC
7: Laurier Avenue West & Site Access #3

2028 Future Total
PM Peak Hour

Intersection						
Int Delay, s/veh	0.6					
Movement	EBL	EBT	WBT	WBR	SBL	SBR
Lane Configurations		↑	↑		↑	↑
Traffic Vol, veh/h	11	339	321	9	10	7
Future Vol, veh/h	11	339	321	9	10	7
Conflicting Peds, #/hr	196	0	0	196	0	0
Sign Control	Free	Free	Free	Free	Stop	Stop
RT Channelized	-	None	-	None	-	None
Storage Length	-	-	-	-	0	-
Veh in Median Storage, #	-	0	0	-	0	-
Grade, %	-	0	0	-	0	-
Peak Hour Factor	100	100	100	100	100	100
Heavy Vehicles, %	2	2	2	2	2	2
Mvmt Flow	11	339	321	9	10	7

Major/Minor	Major1	Major2	Minor2
Conflicting Flow All	526	0	- 883 522
Stage 1	-	-	- 522 -
Stage 2	-	-	- 361 -
Critical Hdwy	4.12	-	- 6.42 6.22
Critical Hdwy Stg 1	-	-	- 5.42 -
Critical Hdwy Stg 2	-	-	- 5.42 -
Follow-up Hdwy	2,218	-	- 3,518 3,318
Pot Cap-1 Maneuver	1041	-	- 316 555
Stage 1	-	-	- 595 -
Stage 2	-	-	- 705 -
Platoon blocked, %	-	-	-
Mov Cap-1 Maneuver	851	-	- 208 454
Mov Cap-2 Maneuver	-	-	- 208 -
Stage 1	-	-	- 478 -
Stage 2	-	-	- 576 -

Approach	EB	WB	SB
HCM Control Delay, s	0.3	0	19.3
HCM LOS			C

Minor Lane/Major Mvmt	EBL	EBT	WBT	WBR	SBLn1
Capacity (veh/h)	851	-	-	-	268
HCM Lane V/C Ratio	0.013	-	-	-	0.063
HCM Control Delay (s)	9.3	0	-	-	19.3
HCM Lane LOS	A	A	-	-	C
HCM 95th %tile Q(veh)	0	-	-	-	0.2

Appendix K

Synchro Intersection Worksheets – 2033 Future Total Conditions

Lanes, Volumes, Timings

2033 Future Total

1: Bank Street & Slater Street /Slater Street

AM Peak Hour



Lane Group	EBL	EBT	EBR	WBL	WBT	WBR	NBL	NBT	NBR	SBL	SBT	SBR
Lane Configurations		↕↕	↕					↕			↕	
Traffic Volume (vph)	22	899	90	0	0	0	0	218	23	14	242	0
Future Volume (vph)	22	899	90	0	0	0	0	218	23	14	242	0
Satd. Flow (prot)	0	2787	1335	0	0	0	0	1413	0	0	1566	0
Fit Permitted		0.999									0.979	
Satd. Flow (perm)	0	2774	876	0	0	0	0	1413	0	0	1519	0
Satd. Flow (RTOR)			62					8				
Lane Group Flow (vph)	0	921	90	0	0	0	0	241	0	0	256	0
Turn Type	pm+pt	NA	Perm					NA	Perm	NA		
Protected Phases	5	2						4			8	
Permitted Phases	2		2							8		
Detector Phase	5	2	2					4		8	8	
Switch Phase												
Minimum Initial (s)	5.0	10.0	10.0					10.0	10.0	10.0		
Minimum Split (s)	10.0	24.0	24.0					35.0	35.0	35.0		
Total Split (s)	12.0	40.0	40.0					35.0	35.0	35.0		
Total Split (%)	16.0%	53.3%	53.3%					46.7%	46.7%	46.7%		
Yellow Time (s)	3.3	3.3	3.3					3.3	3.3	3.3		
All-Red Time (s)	1.7	1.7	1.7					2.2	2.2	2.2		
Lost Time Adjust (s)		0.0	0.0					0.0	0.0	0.0		
Total Lost Time (s)		5.0	5.0					5.5		5.5		
Lead/Lag	Lead										Lag	
Lead-Lag Optimize?	Yes										Yes	
Recall Mode	Max	C-Max	C-Max					Max	Max	Max		
Act Effct Green (s)		35.0	35.0					29.5		29.5		
Actuated g/C Ratio		0.47	0.47					0.39		0.39		
v/c Ratio		0.71	0.20					0.43		0.43		
Control Delay		19.8	6.4					12.3		19.4		
Queue Delay		0.0	0.0					0.0		0.0		
Total Delay		19.8	6.4					12.3		19.4		
LOS		B	A					B		B		
Approach Delay		18.6						12.3		19.4		
Approach LOS		B						B		B		
Queue Length 50th (m)		52.0	2.1					8.8		25.7		
Queue Length 95th (m)		72.8	9.6					34.6		44.4		
Internal Link Dist (m)		64.9				69.8		81.5		43.1		
Turn Bay Length (m)			65.0									
Base Capacity (vph)		1295	441					560		597		
Starvation Cap Reductn		0	0					0		0		
Spillback Cap Reductn		0	0					0		0		
Storage Cap Reductn		0	0					0		0		
Reduced v/c Ratio		0.71	0.20					0.43		0.43		

Intersection Summary

Cycle Length: 75
Actuated Cycle Length: 75
Offset: 48 (64%), Referenced to phase 2:EBTL and 6:Hold, Start of Green
Natural Cycle: 60
Control Type: Actuated-Coordinated

Lanes, Volumes, Timings

2033 Future Total

1: Bank Street & Slater Street /Slater Street

AM Peak Hour

Lane Group	Ø6
Lane Configurations	
Traffic Volume (vph)	
Future Volume (vph)	
Satd. Flow (prot)	
Fit Permitted	
Satd. Flow (perm)	
Satd. Flow (RTOR)	
Lane Group Flow (vph)	
Turn Type	
Protected Phases	6
Permitted Phases	
Detector Phase	
Switch Phase	
Minimum Initial (s)	1.0
Minimum Split (s)	3.0
Total Split (s)	28.0
Total Split (%)	37%
Yellow Time (s)	2.0
All-Red Time (s)	0.0
Lost Time Adjust (s)	
Total Lost Time (s)	
Lead/Lag	Lag
Lead-Lag Optimize?	Yes
Recall Mode	C-Max
Act Effct Green (s)	
Actuated g/C Ratio	
v/c Ratio	
Control Delay	
Queue Delay	
Total Delay	
LOS	
Approach Delay	
Approach LOS	
Queue Length 50th (m)	
Queue Length 95th (m)	
Internal Link Dist (m)	
Turn Bay Length (m)	
Base Capacity (vph)	
Starvation Cap Reductn	
Spillback Cap Reductn	
Storage Cap Reductn	
Reduced v/c Ratio	

Intersection Summary

Cycle Length: 75
Actuated Cycle Length: 75
Offset: 48 (64%), Referenced to phase 2:EBTL and 6:Hold, Start of Green
Natural Cycle: 60
Control Type: Actuated-Coordinated

Lanes, Volumes, Timings
1: Bank Street & Slater Street /Slater Street

2033 Future Total
AM Peak Hour

Maximum v/c Ratio: 0.71	Intersection LOS: B
Intersection Signal Delay: 17.7	ICU Level of Service C
Intersection Capacity Utilization 70.3%	
Analysis Period (min) 15	

Splits and Phases: 1: Bank Street & Slater Street /Slater Street

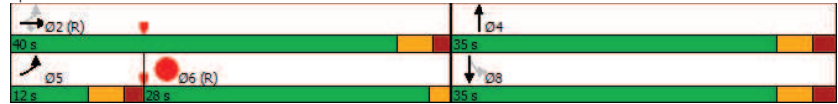

Lanes, Volumes, Timings
2: O'Connor Street & Slater Street

2033 Future Total
AM Peak Hour

Lane Group	EBL	EBT	EBR	WBL	WBT	WBR	NBL	NBT	NBR	SBL	SBT	SBR
Lane Configurations		↑↑	↑							↓	↓↑↑	
Traffic Volume (vph)	0	709	55	0	0	0	0	0	0	119	236	0
Future Volume (vph)	0	709	55	0	0	0	0	0	0	119	236	0
Satd. Flow (prot)	0	2767	1297	0	0	0	0	0	0	1463	4165	0
Fit Permitted										0.950		
Satd. Flow (perm)	0	2767	1035	0	0	0	0	0	0	941	4165	0
Satd. Flow (RTOR)										51		
Lane Group Flow (vph)	0	709	55	0	0	0	0	0	0	119	236	0
Turn Type		NA	Perm							Perm	NA	
Protected Phases		4									6	
Permitted Phases			4									6
Detector Phase		4	4							6	6	
Switch Phase												
Minimum Initial (s)		10.0	10.0							10.0	10.0	
Minimum Split (s)		30.5	30.5							22.5	22.5	
Total Split (s)		41.0	41.0							34.0	34.0	
Total Split (%)		54.7%	54.7%							45.3%	45.3%	
Yellow Time (s)		3.3	3.3							3.3	3.3	
All-Red Time (s)		2.2	2.2							2.2	2.2	
Lost Time Adjust (s)		0.0	0.0							0.0	0.0	
Total Lost Time (s)		5.5	5.5							5.5	5.5	
Lead/Lag												
Lead-Lag Optimize?												
Recall Mode		C-Max	C-Max							Max	Max	
Act Effct Green (s)		35.5	35.5							28.5	28.5	
Actuated g/C Ratio		0.47	0.47							0.38	0.38	
v/c Ratio		0.54	0.11							0.31	0.15	
Control Delay		2.5	1.7							12.4	15.6	
Queue Delay		0.0	0.0							0.0	0.0	
Total Delay		2.5	1.7							12.4	15.6	
LOS		A	A							B	B	
Approach Delay		2.5									14.5	
Approach LOS		A									B	
Queue Length 50th (m)		2.9	0.4							6.3	7.8	
Queue Length 95th (m)		3.7	m0.7							17.9	12.7	
Internal Link Dist (m)		63.6				58.3		84.2			37.7	
Turn Bay Length (m)			30.0									
Base Capacity (vph)		1309	489							389	1582	
Starvation Cap Reductn		0	0							0	0	
Spillback Cap Reductn		0	0							0	0	
Storage Cap Reductn		0	0							0	0	
Reduced v/c Ratio		0.54	0.11							0.31	0.15	

Intersection Summary

Cycle Length: 75
Actuated Cycle Length: 75
Offset: 48 (64%), Referenced to phase 4:EBT, Start of Green
Natural Cycle: 55
Control Type: Actuated-Coordinated

Lanes, Volumes, Timings
2: O'Connor Street & Slater Street

2033 Future Total
AM Peak Hour

Maximum v/c Ratio: 0.54	Intersection LOS: A
Intersection Signal Delay: 6.3	ICU Level of Service A
Intersection Capacity Utilization 46.3%	
Analysis Period (min) 15	

m Volume for 95th percentile queue is metered by upstream signal.

Splits and Phases: 2: O'Connor Street & Slater Street

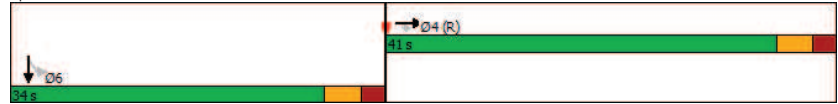

Lanes, Volumes, Timings
3: Bank Street & Laurier Avenue West

2033 Future Total
AM Peak Hour

Lane Group	EBL	EBT	EBR	WBL	WBT	WBR	NBL	NBT	NBR	SBL	SBT	SBR
Lane Configurations		↕	↕		↕			↕	↕		↕	↕
Traffic Volume (vph)	2	245	51	0	242	42	1	192	115	12	266	58
Future Volume (vph)	2	245	51	0	242	42	1	192	115	12	266	58
Satd. Flow (prot)	0	1565	1335	0	1345	0	0	1382	1335	0	1484	1335
Fit Permitted		0.998						0.999			0.987	
Satd. Flow (perm)	0	1558	498	0	1345	0	0	1378	479	0	1437	435
Satd. Flow (RTOR)												
Lane Group Flow (vph)	0	247	51	0	284	0	0	193	115	0	278	58
Turn Type	Perm	NA	Perm	NA	Perm	NA	Perm	NA	Perm	Perm	NA	Perm
Protected Phases		2			6			8			4	
Permitted Phases	2		2				8		8	4		4
Detector Phase	2	2	2		6		8	8	8	4	4	4
Switch Phase												
Minimum Initial (s)	10.0	10.0	10.0		10.0		10.0	10.0	10.0	10.0	10.0	10.0
Minimum Split (s)	23.9	23.9	23.9		23.9		23.6	23.6	23.6	23.6	23.6	23.6
Total Split (s)	27.0	27.0	27.0		27.0		38.0	38.0	38.0	38.0	38.0	38.0
Total Split (%)	36.0%	36.0%	36.0%		36.0%		50.7%	50.7%	50.7%	50.7%	50.7%	50.7%
Yellow Time (s)	3.3	3.3	3.3		3.3		3.3	3.3	3.3	3.3	3.3	3.3
All-Red Time (s)	2.6	2.6	2.6		2.6		2.3	2.3	2.3	2.3	2.3	2.3
Lost Time Adjust (s)		0.0	0.0		0.0		0.0	0.0	0.0	0.0	0.0	0.0
Total Lost Time (s)		5.9	5.9		5.9		5.6	5.6	5.6	5.6	5.6	5.6
Lead/Lag	Lag	Lag	Lag		Lag		Lag	Lag	Lag	Lag	Lag	Lag
Lead-Lag Optimize?	Yes	Yes	Yes		Yes		Yes	Yes	Yes	Yes	Yes	Yes
Recall Mode	C-Max	C-Max	C-Max		C-Max		Max	Max	Max	Max	Max	Max
Act Effct Green (s)	26.1	26.1	26.1		26.1		37.4	37.4	37.4	37.4	37.4	37.4
Actuated g/C Ratio	0.35	0.35			0.35		0.50	0.50		0.50	0.50	
v/c Ratio	0.46	0.29			0.61		0.28	0.48		0.39	0.27	
Control Delay		22.3	23.5		40.1		12.4	21.0		8.1	9.7	
Queue Delay		0.0	0.0		0.0		0.0	0.0		0.0	0.0	
Total Delay		22.3	23.5		40.1		12.4	21.0		8.1	9.7	
LOS		C	C		D		B	C		A	A	
Approach Delay		22.5			40.1		15.6			8.4		
Approach LOS		C			D		B			A		
Queue Length 50th (m)		26.6	5.2		39.4		15.0	10.1		10.7	2.3	
Queue Length 95th (m)		46.1	14.2		63.1		27.4	25.7		18.9	6.0	
Internal Link Dist (m)		75.4			68.9		45.4			81.5		
Turn Bay Length (m)			45.0								10.0	
Base Capacity (vph)		542	173		468		687	238		716	216	
Starvation Cap Reductn		0	0		0		0	0		0	0	
Spillback Cap Reductn		0	0		0		0	0		0	0	
Storage Cap Reductn		0	0		0		0	0		0	0	
Reduced v/c Ratio		0.46	0.29		0.61		0.28	0.48		0.39	0.27	

Intersection Summary												
Cycle Length: 75												
Actuated Cycle Length: 75												
Offset: 40 (53%), Referenced to phase 2:EBTL and 6:WBT, Start of Green												
Natural Cycle: 55												
Control Type: Actuated-Coordinated												

Lanes, Volumes, Timings
 3: Bank Street & Laurier Avenue West

2033 Future Total
 AM Peak Hour

Lane Group	Ø1	Ø3	Ø5	Ø7
Lane Configurations				
Traffic Volume (vph)				
Future Volume (vph)				
Satd. Flow (prot)				
Fit Permitted				
Satd. Flow (perm)				
Satd. Flow (RTOR)				
Lane Group Flow (vph)				
Turn Type				
Protected Phases	1	3	5	7
Permitted Phases				
Detector Phase				
Switch Phase				
Minimum Initial (s)	1.0	1.0	1.0	1.0
Minimum Split (s)	3.0	3.0	3.0	3.0
Total Split (s)	5.0	5.0	5.0	5.0
Total Split (%)	7%	7%	7%	7%
Yellow Time (s)	2.0	2.0	2.0	2.0
All-Red Time (s)	0.0	0.0	0.0	0.0
Lost Time Adjust (s)				
Total Lost Time (s)				
Lead/Lag	Lead	Lead	Lead	Lead
Lead-Lag Optimize?	Yes	Yes	Yes	Yes
Recall Mode	None	None	None	None
Act Effct Green (s)				
Actuated g/C Ratio				
v/c Ratio				
Control Delay				
Queue Delay				
Total Delay				
LOS				
Approach Delay				
Approach LOS				
Queue Length 50th (m)				
Queue Length 95th (m)				
Internal Link Dist (m)				
Turn Bay Length (m)				
Base Capacity (vph)				
Starvation Cap Reductn				
Spillback Cap Reductn				
Storage Cap Reductn				
Reduced v/c Ratio				
Intersection Summary				

Lanes, Volumes, Timings
 3: Bank Street & Laurier Avenue West

2033 Future Total
 AM Peak Hour

Maximum v/c Ratio: 0.61	
Intersection Signal Delay: 21.0	Intersection LOS: C
Intersection Capacity Utilization 63.8%	ICU Level of Service B
Analysis Period (min) 15	

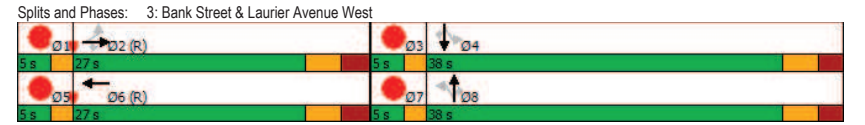

Lanes, Volumes, Timings
4: O'Connor Street & Laurier Avenue West

2033 Future Total
AM Peak Hour

Lane Group	EBL	EBT	EBR	WBL	WBT	WBR	NBL	NBT	NBR	SBL	SBT	SBR
Lane Configurations		↔	↔	↔	↔					↔↔↔		
Traffic Volume (vph)	0	227	155	146	261	0	0	0	0	28	229	22
Future Volume (vph)	0	227	155	146	261	0	0	0	0	28	229	22
Satd. Flow (prot)	0	1262	0	1492	1511	0	0	0	0	0	3897	0
Fit Permitted				0.337							0.995	
Satd. Flow (perm)	0	1262	0	529	1511	0	0	0	0	0	3665	0
Satd. Flow (RTOR)												
Lane Group Flow (vph)	0	382	0	146	261	0	0	0	0	0	279	0
Turn Type		NA		pm+pt	NA					Perm	NA	
Protected Phases		2		9	6							4
Permitted Phases				6							4	
Detector Phase		2		9	6						4	4
Switch Phase												
Minimum Initial (s)		10.0		5.0	10.0					10.0	10.0	
Minimum Split (s)		16.9		10.8	16.9					16.7	16.7	
Total Split (s)		29.0		11.0	45.0					25.0	25.0	
Total Split (%)		38.7%		14.7%	60.0%					33.3%	33.3%	
Yellow Time (s)		3.3		3.3	3.3					3.3	3.3	
All-Red Time (s)		2.6		2.5	2.6					2.4	2.4	
Lost Time Adjust (s)		0.0		0.0	0.0						0.0	
Total Lost Time (s)		5.9		5.8	5.9						5.7	
Lead/Lag				Lead						Lag	Lag	
Lead-Lag Optimize?				Yes						Yes	Yes	
Recall Mode		C-Max		Max	C-Max					Max	Max	
Act Effct Green (s)		28.1		39.2	39.1						24.3	
Actuated g/C Ratio		0.37		0.52	0.52						0.32	
v/c Ratio		0.81		0.43	0.33						0.24	
Control Delay		34.5		13.8	11.9						9.3	
Queue Delay		0.0		0.0	0.0						0.0	
Total Delay		34.5		13.8	11.9						9.3	
LOS		C		B	B						A	
Approach Delay		34.5			12.6						9.3	
Approach LOS		C			B						A	
Queue Length 50th (m)		51.3		10.2	19.9						4.5	
Queue Length 95th (m)		#94.2		19.5	34.5						6.8	
Internal Link Dist (m)		29.1			50.7			45.5			84.2	
Turn Bay Length (m)				15.0								
Base Capacity (vph)		472		343	787						1187	
Starvation Cap Reductn		0		0	0						0	
Spillback Cap Reductn		0		0	0						0	
Storage Cap Reductn		0		0	0						0	
Reduced v/c Ratio		0.81		0.43	0.33						0.24	

Intersection Summary	
Cycle Length: 75	
Actuated Cycle Length: 75	
Offset: 63 (84%), Referenced to phase 2:EBT and 6:WBTL, Start of Green	
Natural Cycle: 65	
Control Type: Actuated-Coordinated	

Lanes, Volumes, Timings
4: O'Connor Street & Laurier Avenue West

2033 Future Total
AM Peak Hour

Lane Group	Ø1	Ø3
Lane Configurations		
Traffic Volume (vph)		
Future Volume (vph)		
Satd. Flow (prot)		
Fit Permitted		
Satd. Flow (perm)		
Satd. Flow (RTOR)		
Lane Group Flow (vph)		
Turn Type		
Protected Phases	1	3
Permitted Phases		
Detector Phase		
Switch Phase		
Minimum Initial (s)	1.0	1.0
Minimum Split (s)	5.0	5.0
Total Split (s)	5.0	5.0
Total Split (%)	7%	7%
Yellow Time (s)	2.0	2.0
All-Red Time (s)	0.0	0.0
Lost Time Adjust (s)		
Total Lost Time (s)		
Lead/Lag	Lag	Lead
Lead-Lag Optimize?	Yes	Yes
Recall Mode	None	None
Act Effct Green (s)		
Actuated g/C Ratio		
v/c Ratio		
Control Delay		
Queue Delay		
Total Delay		
LOS		
Approach Delay		
Approach LOS		
Queue Length 50th (m)		
Queue Length 95th (m)		
Internal Link Dist (m)		
Turn Bay Length (m)		
Base Capacity (vph)		
Starvation Cap Reductn		
Spillback Cap Reductn		
Storage Cap Reductn		
Reduced v/c Ratio		

Intersection Summary	
Cycle Length: 75	
Actuated Cycle Length: 75	
Offset: 63 (84%), Referenced to phase 2:EBT and 6:WBTL, Start of Green	
Natural Cycle: 65	
Control Type: Actuated-Coordinated	

Lanes, Volumes, Timings
4: O'Connor Street & Laurier Avenue West

2033 Future Total
AM Peak Hour

Maximum v/c Ratio: 0.81	Intersection LOS: B
Intersection Signal Delay: 19.5	ICU Level of Service C
Intersection Capacity Utilization 64.3%	
Analysis Period (min) 15	
# 95th percentile volume exceeds capacity, queue may be longer.	
Queue shown is maximum after two cycles.	

Splits and Phases: 4: O'Connor Street & Laurier Avenue West



Lanes, Volumes, Timings
5: Laurier Avenue West & Site Access

2033 Future Total
AM Peak Hour



Lane Group	EBL	EBT	WBT	WBR	SBL	SBR
Lane Configurations		↕	↕			
Traffic Volume (vph)	15	466	353	8	0	0
Future Volume (vph)	15	466	353	8	0	0
Satd. Flow (prot)	0	1567	1566	0	0	0
Fit Permitted		0.998				
Satd. Flow (perm)	0	1567	1566	0	0	0
Lane Group Flow (vph)	0	481	361	0	0	0
Sign Control		Free	Free		Free	

Intersection Summary

Control Type: Unsignalized	
Intersection Capacity Utilization 55.8%	ICU Level of Service B
Analysis Period (min) 15	

HCM 2010 TWSC
6: Site Access & Slater Street

2033 Future Total
AM Peak Hour

Intersection						
Int Delay, s/veh	0					
Movement	EBT	EBR	WBL	WBT	NBL	NBR
Lane Configurations	↑↑					↑
Traffic Vol, veh/h	759	0	0	0	0	3
Future Vol, veh/h	759	0	0	0	0	3
Conflicting Peds, #/hr	0	214	214	0	0	0
Sign Control	Free	Free	Free	Free	Stop	Stop
RT Channelized	-	None	-	None	-	None
Storage Length	-	-	-	-	-	0
Veh in Median Storage, #	0	-	-	-	0	-
Grade, %	0	-	-	0	0	-
Peak Hour Factor	100	100	100	100	100	100
Heavy Vehicles, %	2	2	2	2	2	2
Mvmt Flow	759	0	0	0	0	3
Major/Minor	Major1		Minor1			
Conflicting Flow All	0	-	-	-	-	380
Stage 1	-	-	-	-	-	-
Stage 2	-	-	-	-	-	-
Critical Hdwy	-	-	-	-	-	6.94
Critical Hdwy Stg 1	-	-	-	-	-	-
Critical Hdwy Stg 2	-	-	-	-	-	-
Follow-up Hdwy	-	-	-	-	-	3.32
Pot Cap-1 Maneuver	-	0	0	0	0	618
Stage 1	-	0	0	0	0	-
Stage 2	-	0	0	0	0	-
Platoon blocked, %	-	-	-	-	-	-
Mov Cap-1 Maneuver	-	-	-	-	-	618
Mov Cap-2 Maneuver	-	-	-	-	-	-
Stage 1	-	-	-	-	-	-
Stage 2	-	-	-	-	-	-
Approach	EB		NB			
HCM Control Delay, s	0		10.9			
HCM LOS			B			
Minor Lane/Major Mvmt	NBLn1	EBT				
Capacity (veh/h)	618	-				
HCM Lane V/C Ratio	0.005	-				
HCM Control Delay (s)	10.9	-				
HCM Lane LOS	B	-				
HCM 95th %tile Q(veh)	0	-				

HCM 2010 TWSC
7: Laurier Avenue West & Site Access #3

2033 Future Total
AM Peak Hour

Intersection						
Int Delay, s/veh	0.9					
Movement	EBL	EBT	WBT	WBR	SBL	SBR
Lane Configurations		↑	↑		↑	↑
Traffic Vol, veh/h	8	458	349	6	17	12
Future Vol, veh/h	8	458	349	6	17	12
Conflicting Peds, #/hr	198	0	0	198	0	0
Sign Control	Free	Free	Free	Free	Stop	Stop
RT Channelized	-	None	-	None	-	None
Storage Length	-	-	-	-	0	-
Veh in Median Storage, #	-	0	0	-	0	-
Grade, %	-	0	0	-	0	-
Peak Hour Factor	100	100	100	100	100	100
Heavy Vehicles, %	2	2	2	2	2	2
Mvmt Flow	8	458	349	6	17	12
Major/Minor	Major1	Major2	Minor2			
Conflicting Flow All	553	0	-	0	1024	550
Stage 1	-	-	-	-	550	-
Stage 2	-	-	-	-	474	-
Critical Hdwy	4.12	-	-	-	6.42	6.22
Critical Hdwy Stg 1	-	-	-	-	5.42	-
Critical Hdwy Stg 2	-	-	-	-	5.42	-
Follow-up Hdwy	2,218	-	-	-	3,518	3,318
Pot Cap-1 Maneuver	1017	-	-	-	261	535
Stage 1	-	-	-	-	578	-
Stage 2	-	-	-	-	626	-
Platoon blocked, %	-	-	-	-	-	-
Mov Cap-1 Maneuver	829	-	-	-	171	436
Mov Cap-2 Maneuver	-	-	-	-	171	-
Stage 1	-	-	-	-	465	-
Stage 2	-	-	-	-	511	-
Approach	EB		WB		SB	
HCM Control Delay, s	0.2		0		23.1	
HCM LOS					C	
Minor Lane/Major Mvmt	EBL	EBT	WBT	WBR	SBLn1	SBRn1
Capacity (veh/h)	829	-	-	-	-	228
HCM Lane V/C Ratio	0.01	-	-	-	-	0.127
HCM Control Delay (s)	9.4	0	-	-	-	23.1
HCM Lane LOS	A	A	-	-	-	C
HCM 95th %tile Q(veh)	0	-	-	-	-	0.4

Lanes, Volumes, Timings

1: Bank Street & Slater Street /Slater Street

2033 Future Total

PM Peak Hour

Lane Group	EBL	EBT	EBR	WBL	WBT	WBR	NBL	NBT	NBR	SBL	SBT	SBR
Lane Configurations		↕↕	↕					↕				↕
Traffic Volume (vph)	25	858	154	0	0	0	0	238	19	13	245	0
Future Volume (vph)	25	858	154	0	0	0	0	238	19	13	245	0
Satd. Flow (prot)	0	2910	1335	0	0	0	0	1447	0	0	1461	0
Fit Permitted		0.999									0.981	
Satd. Flow (perm)	0	2890	940	0	0	0	0	1447	0	0	1421	0
Satd. Flow (RTOR)			43					6				
Lane Group Flow (vph)	0	883	154	0	0	0	0	257	0	0	258	0
Turn Type	pm+pt	NA	Perm					NA		Perm	NA	
Protected Phases	5	2						4			8	
Permitted Phases	2		2							8		
Detector Phase	5	2	2					4		8	8	
Switch Phase												
Minimum Initial (s)	5.0	10.0	10.0					10.0		10.0	10.0	
Minimum Split (s)	10.0	24.0	24.0					35.0		35.0	35.0	
Total Split (s)	12.0	40.0	40.0					35.0		35.0	35.0	
Total Split (%)	16.0%	53.3%	53.3%					46.7%		46.7%	46.7%	
Yellow Time (s)	3.3	3.3	3.3					3.3		3.3	3.3	
All-Red Time (s)	1.7	1.7	1.7					2.2		2.2	2.2	
Lost Time Adjust (s)		0.0	0.0					0.0		0.0	0.0	
Total Lost Time (s)		5.0	5.0					5.5		5.5	5.5	
Lead/Lag	Lead										Lag	
Lead-Lag Optimize?	Yes										Yes	
Recall Mode	Max	C-Max	C-Max					Max		Max	Max	
Act Effct Green (s)		35.0	35.0					29.5		29.5	29.5	
Actuated g/C Ratio		0.47	0.47					0.39		0.39	0.39	
v/c Ratio		0.65	0.33					0.45		0.46	0.46	
Control Delay		18.2	11.4					11.9		20.3	20.3	
Queue Delay		0.0	0.0					0.0		0.0	0.0	
Total Delay		18.2	11.4					11.9		20.3	20.3	
LOS		B	B					B		C	C	
Approach Delay		17.2						11.9		20.3	20.3	
Approach LOS		B						B		C	C	
Queue Length 50th (m)		47.9	9.0					11.1		26.3	26.3	
Queue Length 95th (m)		66.9	21.6					17.6		46.0	46.0	
Internal Link Dist (m)		64.9				70.6		81.5		43.1	43.1	
Turn Bay Length (m)			65.0									
Base Capacity (vph)		1350	461					572		558	558	
Starvation Cap Reductn		0	0					0		0	0	
Spillback Cap Reductn		0	0					0		0	0	
Storage Cap Reductn		0	0					0		0	0	
Reduced v/c Ratio		0.65	0.33					0.45		0.46	0.46	

Intersection Summary

Cycle Length: 75

Actuated Cycle Length: 75

Offset: 20 (27%), Referenced to phase 2:EBTL and 6:Hold, Start of Green

Natural Cycle: 60

Control Type: Actuated-Coordinated

Lanes, Volumes, Timings

1: Bank Street & Slater Street /Slater Street

2033 Future Total

PM Peak Hour

Lane Group	Ø6
Lane Configurations	
Traffic Volume (vph)	
Future Volume (vph)	
Satd. Flow (prot)	
Fit Permitted	
Satd. Flow (perm)	
Satd. Flow (RTOR)	
Lane Group Flow (vph)	
Turn Type	
Protected Phases	6
Permitted Phases	
Detector Phase	
Switch Phase	
Minimum Initial (s)	1.0
Minimum Split (s)	3.0
Total Split (s)	28.0
Total Split (%)	37%
Yellow Time (s)	2.0
All-Red Time (s)	0.0
Lost Time Adjust (s)	
Total Lost Time (s)	
Lead/Lag	Lag
Lead-Lag Optimize?	Yes
Recall Mode	C-Max
Act Effct Green (s)	
Actuated g/C Ratio	
v/c Ratio	
Control Delay	
Queue Delay	
Total Delay	
LOS	
Approach Delay	
Approach LOS	
Queue Length 50th (m)	
Queue Length 95th (m)	
Internal Link Dist (m)	
Turn Bay Length (m)	
Base Capacity (vph)	
Starvation Cap Reductn	
Spillback Cap Reductn	
Storage Cap Reductn	
Reduced v/c Ratio	

Intersection Summary

Lanes, Volumes, Timings
1: Bank Street & Slater Street /Slater Street

2033 Future Total
PM Peak Hour

Maximum v/c Ratio: 0.65	Intersection LOS: B
Intersection Signal Delay: 16.8	ICU Level of Service C
Intersection Capacity Utilization 68.3%	
Analysis Period (min) 15	



Lanes, Volumes, Timings
2: O'Connor Street & Slater Street

2033 Future Total
PM Peak Hour

Lane Group	EBL	EBT	EBR	WBL	WBT	WBR	NBL	NBT	NBR	SBL	SBT	SBR
Lane Configurations		↑↑	↑							↓	↓↑↑	
Traffic Volume (vph)	0	855	61	0	0	0	0	0	0	105	361	0
Future Volume (vph)	0	855	61	0	0	0	0	0	0	105	361	0
Satd. Flow (prot)	0	2899	1322	0	0	0	0	0	0	1436	4288	0
Fit Permitted										0.950		
Satd. Flow (perm)	0	2899	1060	0	0	0	0	0	0	975	4288	0
Satd. Flow (RTOR)										50		
Lane Group Flow (vph)	0	855	61	0	0	0	0	0	0	105	361	0
Turn Type		NA	Perm							Perm	NA	
Protected Phases		4									6	
Permitted Phases			4									6
Detector Phase		4	4								6	6
Switch Phase												
Minimum Initial (s)		10.0	10.0							10.0	10.0	
Minimum Split (s)		30.5	30.5							22.5	22.5	
Total Split (s)		45.0	45.0							30.0	30.0	
Total Split (%)		60.0%	60.0%							40.0%	40.0%	
Yellow Time (s)		3.3	3.3							3.3	3.3	
All-Red Time (s)		2.2	2.2							2.2	2.2	
Lost Time Adjust (s)		0.0	0.0							0.0	0.0	
Total Lost Time (s)		5.5	5.5							5.5	5.5	
Lead/Lag												
Lead-Lag Optimize?												
Recall Mode		C-Max	C-Max							Max	Max	
Act Effct Green (s)		39.5	39.5							24.5	24.5	
Actuated g/C Ratio		0.53	0.53							0.33	0.33	
v/c Ratio		0.56	0.11							0.30	0.26	
Control Delay		4.0	3.1							13.6	19.2	
Queue Delay		0.0	0.0							0.0	0.0	
Total Delay		4.0	3.1							13.6	19.2	
LOS		A	A							B	B	
Approach Delay		3.9									17.9	
Approach LOS		A									B	
Queue Length 50th (m)		7.1	1.0							5.5	13.5	
Queue Length 95th (m)		9.0	m1.5							16.9	20.3	
Internal Link Dist (m)		62.8				58.3		84.2			37.7	
Turn Bay Length (m)			30.0									
Base Capacity (vph)		1526	558							352	1400	
Starvation Cap Reductn		0	0							0	0	
Spillback Cap Reductn		0	0							0	0	
Storage Cap Reductn		0	0							0	0	
Reduced v/c Ratio		0.56	0.11							0.30	0.26	

Intersection Summary	
Cycle Length:	75
Actuated Cycle Length:	75
Offset:	12 (16%), Referenced to phase 4:EBT, Start of Green
Natural Cycle:	55
Control Type:	Actuated-Coordinated

Lanes, Volumes, Timings
2: O'Connor Street & Slater Street

2033 Future Total
PM Peak Hour

Maximum v/c Ratio: 0.56	Intersection LOS: A
Intersection Signal Delay: 8.7	ICU Level of Service A
Intersection Capacity Utilization 51.1%	
Analysis Period (min) 15	
m Volume for 95th percentile queue is metered by upstream signal.	

Splits and Phases: 2: O'Connor Street & Slater Street

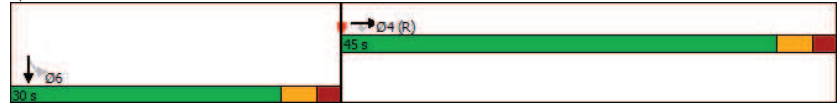

Lanes, Volumes, Timings
3: Bank Street & Laurier Avenue West

2033 Future Total
PM Peak Hour

Lane Group	EBL	EBT	EBR	WBL	WBT	WBR	NBL	NBT	NBR	SBL	SBT	SBR
Lane Configurations		↕	↕		↕			↕	↕		↕	↕
Traffic Volume (vph)	0	246	80	2	222	63	1	207	87	18	315	76
Future Volume (vph)	0	246	80	2	222	63	1	207	87	18	315	76
Satd. Flow (prot)	0	1571	1335	0	1326	0	0	1491	1335	0	1537	1335
Fit Permitted					0.998			0.999			0.980	
Satd. Flow (perm)	0	1571	471	0	1320	0	0	1487	223	0	1462	261
Satd. Flow (RTOR)												
Lane Group Flow (vph)	0	246	80	0	287	0	0	208	87	0	333	76
Turn Type		NA	Perm	Perm	NA		Perm	NA	Perm	Perm	NA	Perm
Protected Phases		2			6			8			4	
Permitted Phases	2		2	6			8		8	4		4
Detector Phase	2	2	2	6	6		8	8	8	4	4	4
Switch Phase												
Minimum Initial (s)	10.0	10.0	10.0	10.0	10.0		10.0	10.0	10.0	10.0	10.0	10.0
Minimum Split (s)	23.9	23.9	23.9	23.9	23.9		23.6	23.6	23.6	23.6	23.6	23.6
Total Split (s)	30.0	30.0	30.0	30.0	30.0		35.0	35.0	35.0	35.0	35.0	35.0
Total Split (%)	40.0%	40.0%	40.0%	40.0%	40.0%		46.7%	46.7%	46.7%	46.7%	46.7%	46.7%
Yellow Time (s)	3.3	3.3	3.3	3.3	3.3		3.3	3.3	3.3	3.3	3.3	3.3
All-Red Time (s)	2.6	2.6	2.6	2.6	2.6		2.3	2.3	2.3	2.3	2.3	2.3
Lost Time Adjust (s)		0.0	0.0		0.0			0.0	0.0		0.0	0.0
Total Lost Time (s)		5.9	5.9		5.9			5.6	5.6		5.6	5.6
Lead/Lag	Lag	Lag	Lag	Lag	Lag		Lag	Lag	Lag	Lag	Lag	Lag
Lead-Lag Optimize?	Yes	Yes	Yes	Yes	Yes		Yes	Yes	Yes	Yes	Yes	Yes
Recall Mode	C-Max	C-Max	C-Max	C-Max	C-Max		Max	Max	Max	Max	Max	Max
Act Effct Green (s)	29.1	29.1		29.1			34.4	34.4		34.4		34.4
Actuated g/C Ratio	0.39	0.39		0.39			0.46	0.46		0.46		0.46
v/c Ratio	0.40	0.44		0.56			0.30	0.85		0.50		0.64
Control Delay	19.2	26.4		15.8			14.4	82.6		12.4		37.7
Queue Delay	0.0	0.0		0.0			0.0	0.0		0.2		0.0
Total Delay	19.2	26.4		15.8			14.4	82.6		12.6		37.7
LOS	B	C		B			B	F		B		D
Approach Delay	21.0			15.8			34.5			17.3		
Approach LOS	C			B			C			B		
Queue Length 50th (m)	24.6	8.1		16.1			17.7	10.4		20.5		4.9
Queue Length 95th (m)	42.7	21.2		25.1			31.7	#36.9		32.7		#29.4
Internal Link Dist (m)	75.4			68.9			45.4			81.5		
Turn Bay Length (m)			45.0									10.0
Base Capacity (vph)		609	182		512		682	102		670		119
Starvation Cap Reductn	0	0		0			0	0		56		0
Spillback Cap Reductn	0	0		0			0	0		0		0
Storage Cap Reductn	0	0		0			0	0		0		0
Reduced v/c Ratio		0.40	0.44		0.56		0.30	0.85		0.54		0.64

Intersection Summary												
Cycle Length: 75												
Actuated Cycle Length: 75												
Offset: 11 (15%), Referenced to phase 2:EBTL and 6:WBTL, Start of Green												
Natural Cycle: 60												
Control Type: Actuated-Coordinated												

Lanes, Volumes, Timings
 3: Bank Street & Laurier Avenue West

2033 Future Total
 PM Peak Hour

Lane Group	Ø1	Ø3	Ø5	Ø7
Lane Configurations				
Traffic Volume (vph)				
Future Volume (vph)				
Satd. Flow (prot)				
Fit Permitted				
Satd. Flow (perm)				
Satd. Flow (RTOR)				
Lane Group Flow (vph)				
Turn Type				
Protected Phases	1	3	5	7
Permitted Phases				
Detector Phase				
Switch Phase				
Minimum Initial (s)	1.0	1.0	1.0	1.0
Minimum Split (s)	3.0	3.0	3.0	3.0
Total Split (s)	5.0	5.0	5.0	5.0
Total Split (%)	7%	7%	7%	7%
Yellow Time (s)	2.0	2.0	2.0	2.0
All-Red Time (s)	0.0	0.0	0.0	0.0
Lost Time Adjust (s)				
Total Lost Time (s)				
Lead/Lag	Lead	Lead	Lead	Lead
Lead-Lag Optimize?	Yes	Yes	Yes	Yes
Recall Mode	None	None	None	None
Act Effct Green (s)				
Actuated g/C Ratio				
v/c Ratio				
Control Delay				
Queue Delay				
Total Delay				
LOS				
Approach Delay				
Approach LOS				
Queue Length 50th (m)				
Queue Length 95th (m)				
Internal Link Dist (m)				
Turn Bay Length (m)				
Base Capacity (vph)				
Starvation Cap Reductn				
Spillback Cap Reductn				
Storage Cap Reductn				
Reduced v/c Ratio				
Intersection Summary				

Lanes, Volumes, Timings
 3: Bank Street & Laurier Avenue West

2033 Future Total
 PM Peak Hour

Maximum v/c Ratio: 0.85	
Intersection Signal Delay: 21.7	Intersection LOS: C
Intersection Capacity Utilization 69.5%	ICU Level of Service C
Analysis Period (min) 15	
# 95th percentile volume exceeds capacity, queue may be longer.	
Queue shown is maximum after two cycles.	

Splits and Phases: 3: Bank Street & Laurier Avenue West

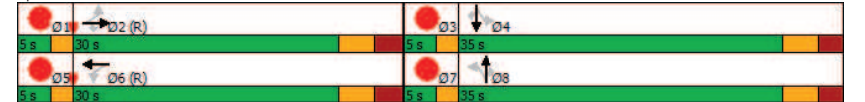

Lanes, Volumes, Timings
4: O'Connor Street & Laurier Avenue West

2033 Future Total
PM Peak Hour

Lane Group	EBL	EBT	EBR	WBL	WBT	WBR	NBL	NBT	NBR	SBL	SBT	SBR
Lane Configurations		↔	↔	↔	↔					↔↔↔		
Traffic Volume (vph)	0	247	97	196	294	0	0	0	0	55	348	32
Future Volume (vph)	0	247	97	196	294	0	0	0	0	55	348	32
Satd. Flow (prot)	0	1345	0	1492	1571	0	0	0	0	0	4013	0
Fit Permitted				0.375							0.994	
Satd. Flow (perm)	0	1345	0	589	1571	0	0	0	0	0	3709	0
Satd. Flow (RTOR)												
Lane Group Flow (vph)	0	344	0	196	294	0	0	0	0	0	435	0
Turn Type		NA		pm+pt	NA					Perm	NA	
Protected Phases		2		9	6						4	
Permitted Phases				6						4		
Detector Phase		2		9	6					4	4	
Switch Phase												
Minimum Initial (s)		10.0		5.0	10.0					10.0	10.0	
Minimum Split (s)		16.9		10.8	16.9					16.7	16.7	
Total Split (s)		29.0		11.0	45.0					25.0	25.0	
Total Split (%)		38.7%		14.7%	60.0%					33.3%	33.3%	
Yellow Time (s)		3.3		3.3	3.3					3.3	3.3	
All-Red Time (s)		2.6		2.5	2.6					2.4	2.4	
Lost Time Adjust (s)		0.0		0.0	0.0						0.0	
Total Lost Time (s)		5.9		5.8	5.9						5.7	
Lead/Lag				Lead						Lag	Lag	
Lead-Lag Optimize?				Yes						Yes	Yes	
Recall Mode		C-Max		Max	C-Max					Max	Max	
Act Effct Green (s)		28.1		39.2	39.1						24.3	
Actuated g/C Ratio		0.37		0.52	0.52						0.32	
v/c Ratio		0.68		0.53	0.36						0.36	
Control Delay		19.8		16.1	12.2						10.7	
Queue Delay		0.0		0.0	0.0						0.0	
Total Delay		19.8		16.1	12.2						10.7	
LOS		B		B	B						B	
Approach Delay		19.8			13.8						10.7	
Approach LOS		B			B						B	
Queue Length 50th (m)		18.6		14.2	22.8						7.4	
Queue Length 95th (m)		m69.0		25.6	38.6						9.7	
Internal Link Dist (m)		25.2			50.7			45.5			84.2	
Turn Bay Length (m)				15.0								
Base Capacity (vph)		503		370	819						1201	
Starvation Cap Reductn		0		0	0						0	
Spillback Cap Reductn		0		0	0						0	
Storage Cap Reductn		0		0	0						0	
Reduced v/c Ratio		0.68		0.53	0.36						0.36	

Intersection Summary	
Cycle Length: 75	
Actuated Cycle Length: 75	
Offset: 22 (29%), Referenced to phase 2:EBT and 6:WBTL, Start of Green	
Natural Cycle: 65	
Control Type: Actuated-Coordinated	

Lanes, Volumes, Timings
4: O'Connor Street & Laurier Avenue West

2033 Future Total
PM Peak Hour

Lane Group	Ø1	Ø3
Lane Configurations		
Traffic Volume (vph)		
Future Volume (vph)		
Satd. Flow (prot)		
Fit Permitted		
Satd. Flow (perm)		
Satd. Flow (RTOR)		
Lane Group Flow (vph)		
Turn Type		
Protected Phases	1	3
Permitted Phases		
Detector Phase		
Switch Phase		
Minimum Initial (s)	1.0	1.0
Minimum Split (s)	5.0	5.0
Total Split (s)	5.0	5.0
Total Split (%)	7%	7%
Yellow Time (s)	2.0	2.0
All-Red Time (s)	0.0	0.0
Lost Time Adjust (s)		
Total Lost Time (s)		
Lead/Lag	Lag	Lead
Lead-Lag Optimize?	Yes	Yes
Recall Mode	None	None
Act Effct Green (s)		
Actuated g/C Ratio		
v/c Ratio		
Control Delay		
Queue Delay		
Total Delay		
LOS		
Approach Delay		
Approach LOS		
Queue Length 50th (m)		
Queue Length 95th (m)		
Internal Link Dist (m)		
Turn Bay Length (m)		
Base Capacity (vph)		
Starvation Cap Reductn		
Spillback Cap Reductn		
Storage Cap Reductn		
Reduced v/c Ratio		

Intersection Summary	
Cycle Length: 75	
Actuated Cycle Length: 75	
Offset: 22 (29%), Referenced to phase 2:EBT and 6:WBTL, Start of Green	
Natural Cycle: 65	
Control Type: Actuated-Coordinated	

Lanes, Volumes, Timings
 4: O'Connor Street & Laurier Avenue West

2033 Future Total
 PM Peak Hour

Maximum v/c Ratio: 0.68	Intersection LOS: B
Intersection Signal Delay: 14.3	ICU Level of Service C
Intersection Capacity Utilization 64.8%	
Analysis Period (min) 15	

m Volume for 95th percentile queue is metered by upstream signal.

Splits and Phases: 4: O'Connor Street & Laurier Avenue West



Lanes, Volumes, Timings
 5: Laurier Avenue West & Site Access

2033 Future Total
 PM Peak Hour



Lane Group	EBL	EBT	WBT	WBR	SBL	SBR
Lane Configurations		↕	↕			
Traffic Volume (vph)	4	350	323	5	0	0
Future Volume (vph)	4	350	323	5	0	0
Satd. Flow (prot)	0	1569	1567	0	0	0
Fit Permitted		0.999				
Satd. Flow (perm)	0	1569	1567	0	0	0
Lane Group Flow (vph)	0	354	328	0	0	0
Sign Control		Free	Free		Free	

Intersection Summary	
Control Type: Unsignalized	
Intersection Capacity Utilization 38.2%	ICU Level of Service A
Analysis Period (min) 15	

HCM 2010 TWSC
6: Site Access & Slater Street

2033 Future Total
PM Peak Hour

Intersection						
Int Delay, s/veh	0.4					
Movement	EBT	EBR	WBL	WBT	NBL	NBR
Lane Configurations	↑↑					↑
Traffic Vol, veh/h	888	0	0	0	0	28
Future Vol, veh/h	888	0	0	0	0	28
Conflicting Peds, #/hr	0	208	208	0	0	0
Sign Control	Free	Free	Free	Free	Stop	Stop
RT Channelized	-	None	-	None	-	None
Storage Length	-	-	-	-	-	0
Veh in Median Storage, #	0	-	-	-	0	-
Grade, %	0	-	-	0	0	-
Peak Hour Factor	100	100	100	100	100	100
Heavy Vehicles, %	2	2	2	2	2	2
Mvmt Flow	888	0	0	0	0	28
Major/Minor	Major1		Minor1			
Conflicting Flow All	0	-	-	-	-	444
Stage 1	-	-	-	-	-	-
Stage 2	-	-	-	-	-	-
Critical Hdwy	-	-	-	-	-	6.94
Critical Hdwy Stg 1	-	-	-	-	-	-
Critical Hdwy Stg 2	-	-	-	-	-	-
Follow-up Hdwy	-	-	-	-	-	3.32
Pot Cap-1 Maneuver	-	0	0	0	0	561
Stage 1	-	0	0	0	0	-
Stage 2	-	0	0	0	0	-
Platoon blocked, %	-	-	-	-	-	-
Mov Cap-1 Maneuver	-	-	-	-	-	561
Mov Cap-2 Maneuver	-	-	-	-	-	-
Stage 1	-	-	-	-	-	-
Stage 2	-	-	-	-	-	-
Approach	EB		NB			
HCM Control Delay, s	0		11.8			
HCM LOS			B			
Minor Lane/Major Mvmt	NBLn1	EBT				
Capacity (veh/h)	561	-				
HCM Lane V/C Ratio	0.05	-				
HCM Control Delay (s)	11.8	-				
HCM Lane LOS	B	-				
HCM 95th %tile Q(veh)	0.2	-				

HCM 2010 TWSC
7: Laurier Avenue West & Site Access #3

2033 Future Total
PM Peak Hour

Intersection						
Int Delay, s/veh	0.6					
Movement	EBL	EBT	WBT	WBR	SBL	SBR
Lane Configurations		↑	↑		↑	↑
Traffic Vol, veh/h	11	339	321	9	10	7
Future Vol, veh/h	11	339	321	9	10	7
Conflicting Peds, #/hr	196	0	0	196	0	0
Sign Control	Free	Free	Free	Free	Stop	Stop
RT Channelized	-	None	-	None	-	None
Storage Length	-	-	-	-	0	-
Veh in Median Storage, #	-	0	0	-	0	-
Grade, %	-	0	0	-	0	-
Peak Hour Factor	100	100	100	100	100	100
Heavy Vehicles, %	2	2	2	2	2	2
Mvmt Flow	11	339	321	9	10	7
Major/Minor	Major1	Major2	Minor2			
Conflicting Flow All	526	0	-	0	883	522
Stage 1	-	-	-	-	522	-
Stage 2	-	-	-	-	361	-
Critical Hdwy	4.12	-	-	-	6.42	6.22
Critical Hdwy Stg 1	-	-	-	-	5.42	-
Critical Hdwy Stg 2	-	-	-	-	5.42	-
Follow-up Hdwy	2,218	-	-	-	3,518	3,318
Pot Cap-1 Maneuver	1041	-	-	-	316	555
Stage 1	-	-	-	-	595	-
Stage 2	-	-	-	-	705	-
Platoon blocked, %	-	-	-	-	-	-
Mov Cap-1 Maneuver	851	-	-	-	208	454
Mov Cap-2 Maneuver	-	-	-	-	208	-
Stage 1	-	-	-	-	478	-
Stage 2	-	-	-	-	576	-
Approach	EB		WB		SB	
HCM Control Delay, s	0.3		0		19.3	
HCM LOS					C	
Minor Lane/Major Mvmt	EBL	EBT	WBT	WBR	SBLn1	SBRn1
Capacity (veh/h)	851	-	-	-	-	268
HCM Lane V/C Ratio	0.013	-	-	-	-	0.063
HCM Control Delay (s)	9.3	0	-	-	-	19.3
HCM Lane LOS	A	A	-	-	-	C
HCM 95th %tile Q(veh)	0	-	-	-	-	0.2

Appendix L

TDM Checklist

TDM-Supportive Development Design and Infrastructure Checklist:
Non-Residential Developments (office, institutional, retail or industrial)

Legend	
REQUIRED	The Official Plan or Zoning By-law provides related guidance that must be followed
BASIC	The measure is generally feasible and effective, and in most cases would benefit the development and its users
BETTER	The measure could maximize support for users of sustainable modes, and optimize development performance

TDM-supportive design & infrastructure measures: <i>Non-residential developments</i>		Check if completed & add descriptions, explanations or plan/drawing references
1. WALKING & CYCLING: ROUTES		
1.1 Building location & access points		
BASIC	1.1.1 Locate building close to the street, and do not locate parking areas between the street and building entrances	<input type="checkbox"/>
BASIC	1.1.2 Locate building entrances in order to minimize walking distances to sidewalks and transit stops/stations	<input type="checkbox"/>
BASIC	1.1.3 Locate building doors and windows to ensure visibility of pedestrians from the building, for their security and comfort	<input type="checkbox"/>
1.2 Facilities for walking & cycling		
REQUIRED	1.2.1 Provide convenient, direct access to stations or major stops along rapid transit routes within 600 metres; minimize walking distances from buildings to rapid transit; provide pedestrian-friendly, weather-protected (where possible) environment between rapid transit accesses and building entrances; ensure quality linkages from sidewalks through building entrances to integrated stops/stations (see <i>Official Plan policy 4.3.3</i>)	<input checked="" type="checkbox"/>
REQUIRED	1.2.2 Provide safe, direct and attractive pedestrian access from public sidewalks to building entrances through such measures as: reducing distances between public sidewalks and major building entrances; providing walkways from public streets to major building entrances; within a site, providing walkways along the front of adjoining buildings, between adjacent buildings, and connecting areas where people may congregate, such as courtyards and transit stops; and providing weather protection through canopies, colonnades, and other design elements wherever possible (see <i>Official Plan policy 4.3.12</i>)	<input checked="" type="checkbox"/>

TDM-supportive design & infrastructure measures: <i>Non-residential developments</i>		Check if completed & add descriptions, explanations or plan/drawing references
REQUIRED	1.2.3 Provide sidewalks of smooth, well-drained walking surfaces of contrasting materials or treatments to differentiate pedestrian areas from vehicle areas, and provide marked pedestrian crosswalks at intersection sidewalks (see <i>Official Plan policy 4.3.10</i>)	<input checked="" type="checkbox"/>
REQUIRED	1.2.4 Make sidewalks and open space areas easily accessible through features such as gradual grade transition, depressed curbs at street corners and convenient access to extra-wide parking spaces and ramps (see <i>Official Plan policy 4.3.10</i>)	<input checked="" type="checkbox"/>
REQUIRED	1.2.5 Include adequately spaced inter-block/street cycling and pedestrian connections to facilitate travel by active transportation. Provide links to the existing or planned network of public sidewalks, multi-use pathways and on-road cycle routes. Where public sidewalks and multi-use pathways intersect with roads, consider providing traffic control devices to give priority to cyclists and pedestrians (see <i>Official Plan policy 4.3.11</i>)	<input checked="" type="checkbox"/>
BASIC	1.2.6 Provide safe, direct and attractive walking routes from building entrances to nearby transit stops	<input checked="" type="checkbox"/>
BASIC	1.2.7 Ensure that walking routes to transit stops are secure, visible, lighted, shaded and wind-protected wherever possible	<input checked="" type="checkbox"/>
BASIC	1.2.8 Design roads used for access or circulation by cyclists using a target operating speed of no more than 30 km/h, or provide a separated cycling facility	<input type="checkbox"/>
1.3 Amenities for walking & cycling		
BASIC	1.3.1 Provide lighting, landscaping and benches along walking and cycling routes between building entrances and streets, sidewalks and trails	<input type="checkbox"/>
BASIC	1.3.2 Provide wayfinding signage for site access (where required, e.g. when multiple buildings or entrances exist) and egress (where warranted, such as when directions to reach transit stops/stations, trails or other common destinations are not obvious)	<input type="checkbox"/>

TDM-supportive design & infrastructure measures: <i>Non-residential developments</i>		Check if completed & add descriptions, explanations or plan/drawing references
2. WALKING & CYCLING: END-OF-TRIP FACILITIES		
2.1 Bicycle parking		
REQUIRED	2.1.1 Provide bicycle parking in highly visible and lighted areas, sheltered from the weather wherever possible (see <i>Official Plan policy 4.3.6</i>)	<input checked="" type="checkbox"/>
REQUIRED	2.1.2 Provide the number of bicycle parking spaces specified for various land uses in different parts of Ottawa; provide convenient access to main entrances or well-used areas (see <i>Zoning By-law Section 111</i>)	<input checked="" type="checkbox"/>
REQUIRED	2.1.3 Ensure that bicycle parking spaces and access aisles meet minimum dimensions; that no more than 50% of spaces are vertical spaces; and that parking racks are securely anchored (see <i>Zoning By-law Section 111</i>)	<input checked="" type="checkbox"/>
BASIC	2.1.4 Provide bicycle parking spaces equivalent to the expected number of commuter cyclists (assuming the cycling mode share target is met), plus the expected peak number of customer/visitor cyclists	<input type="checkbox"/>
BETTER	2.1.5 Provide bicycle parking spaces equivalent to the expected number of commuter and customer/visitor cyclists, plus an additional buffer (e.g. 25 percent extra) to encourage other cyclists and ensure adequate capacity in peak cycling season	<input type="checkbox"/>
2.2 Secure bicycle parking		
REQUIRED	2.2.1 Where more than 50 bicycle parking spaces are provided for a single office building, locate at least 25% of spaces within a building/structure, a secure area (e.g. supervised parking lot or enclosure) or bicycle lockers (see <i>Zoning By-law Section 111</i>)	<input checked="" type="checkbox"/>
BETTER	2.2.2 Provide secure bicycle parking spaces equivalent to the expected number of commuter cyclists (assuming the cycling mode share target is met)	<input type="checkbox"/>
2.3 Shower & change facilities		
BASIC	2.3.1 Provide shower and change facilities for the use of active commuters	<input type="checkbox"/>
BETTER	2.3.2 In addition to shower and change facilities, provide dedicated lockers, grooming stations, drying racks and laundry facilities for the use of active commuters	<input type="checkbox"/>
2.4 Bicycle repair station		
BETTER	2.4.1 Provide a permanent bike repair station, with commonly used tools and an air pump, adjacent to the main bicycle parking area (or secure bicycle parking area, if provided)	<input type="checkbox"/>

TDM-supportive design & infrastructure measures: <i>Non-residential developments</i>		Check if completed & add descriptions, explanations or plan/drawing references
3. TRANSIT		
3.1 Customer amenities		
BASIC	3.1.1 Provide shelters, lighting and benches at any on-site transit stops	<input type="checkbox"/>
BASIC	3.1.2 Where the site abuts an off-site transit stop and insufficient space exists for a transit shelter in the public right-of-way, protect land for a shelter and/or install a shelter	<input type="checkbox"/>
BETTER	3.1.3 Provide a secure and comfortable interior waiting area by integrating any on-site transit stops into the building	<input type="checkbox"/>
4. RIDESHARING		
4.1 Pick-up & drop-off facilities		
BASIC	4.1.1 Provide a designated area for carpool drivers (plus taxis and ride-hailing services) to drop off or pick up passengers without using fire lanes or other no-stopping zones	<input type="checkbox"/>
4.2 Carpool parking		
BASIC	4.2.1 Provide signed parking spaces for carpools in a priority location close to a major building entrance, sufficient in number to accommodate the mode share target for carpools	<input type="checkbox"/>
BETTER	4.2.2 At large developments, provide spaces for carpools in a separate, access-controlled parking area to simplify enforcement	<input type="checkbox"/>
5. CARSHARING & BIKESHARING		
5.1 Carshare parking spaces		
BETTER	5.1.1 Provide carshare parking spaces in permitted non-residential zones, occupying either required or provided parking spaces (see <i>Zoning By-law Section 94</i>)	<input type="checkbox"/>
5.2 Bikeshare station location		
BETTER	5.2.1 Provide a designated bikeshare station area near a major building entrance, preferably lighted and sheltered with a direct walkway connection	<input type="checkbox"/>

TDM-supportive design & infrastructure measures: <i>Non-residential developments</i>		Check if completed & add descriptions, explanations or plan/drawing references
6. PARKING		
6.1 Number of parking spaces		
REQUIRED	6.1.1 Do not provide more parking than permitted by zoning, nor less than required by zoning, unless a variance is being applied for	<input checked="" type="checkbox"/>
BASIC	6.1.2 Provide parking for long-term and short-term users that is consistent with mode share targets, considering the potential for visitors to use off-site public parking	<input type="checkbox"/>
BASIC	6.1.3 Where a site features more than one use, provide shared parking and reduce the cumulative number of parking spaces accordingly (see <i>Zoning By-law Section 104</i>)	<input type="checkbox"/>
BETTER	6.1.4 Reduce the minimum number of parking spaces required by zoning by one space for each 13 square metres of gross floor area provided as shower rooms, change rooms, locker rooms and other facilities for cyclists in conjunction with bicycle parking (see <i>Zoning By-law Section 111</i>)	<input type="checkbox"/>
6.2 Separate long-term & short-term parking areas		
BETTER	6.2.1 Separate short-term and long-term parking areas using signage or physical barriers, to permit access controls and simplify enforcement (i.e. to discourage employees from parking in visitor spaces, and vice versa)	<input type="checkbox"/>
7. OTHER		
7.1 On-site amenities to minimize off-site trips		
BETTER	7.1.1 Provide on-site amenities to minimize mid-day or mid-commute errands	<input type="checkbox"/>

**TDM-Supportive Development Design and Infrastructure Checklist:
Residential Developments (multi-family or condominium)**

Legend	
REQUIRED	The Official Plan or Zoning By-law provides related guidance that must be followed
BASIC	The measure is generally feasible and effective, and in most cases would benefit the development and its users
BETTER	The measure could maximize support for users of sustainable modes, and optimize development performance

TDM-supportive design & infrastructure measures: <i>Residential developments</i>		Check if completed & add descriptions, explanations or plan/drawing references
1. WALKING & CYCLING: ROUTES		
1.1 Building location & access points		
BASIC	1.1.1 Locate building close to the street, and do not locate parking areas between the street and building entrances	<input type="checkbox"/>
BASIC	1.1.2 Locate building entrances in order to minimize walking distances to sidewalks and transit stops/stations	<input type="checkbox"/>
BASIC	1.1.3 Locate building doors and windows to ensure visibility of pedestrians from the building, for their security and comfort	<input type="checkbox"/>
1.2 Facilities for walking & cycling		
REQUIRED	1.2.1 Provide convenient, direct access to stations or major stops along rapid transit routes within 600 metres; minimize walking distances from buildings to rapid transit; provide pedestrian-friendly, weather-protected (where possible) environment between rapid transit accesses and building entrances; ensure quality linkages from sidewalks through building entrances to integrated stops/stations (see <i>Official Plan policy 4.3.3</i>)	<input checked="" type="checkbox"/>
REQUIRED	1.2.2 Provide safe, direct and attractive pedestrian access from public sidewalks to building entrances through such measures as: reducing distances between public sidewalks and major building entrances; providing walkways from public streets to major building entrances; within a site, providing walkways along the front of adjoining buildings, between adjacent buildings, and connecting areas where people may congregate, such as courtyards and transit stops; and providing weather protection through canopies, colonnades, and other design elements wherever possible (see <i>Official Plan policy 4.3.12</i>)	<input checked="" type="checkbox"/>

TDM-supportive design & infrastructure measures: <i>Residential developments</i>		Check if completed & add descriptions, explanations or plan/drawing references
REQUIRED	1.2.3 Provide sidewalks of smooth, well-drained walking surfaces of contrasting materials or treatments to differentiate pedestrian areas from vehicle areas, and provide marked pedestrian crosswalks at intersection sidewalks (see <i>Official Plan policy 4.3.10</i>)	<input checked="" type="checkbox"/>
REQUIRED	1.2.4 Make sidewalks and open space areas easily accessible through features such as gradual grade transition, depressed curbs at street corners and convenient access to extra-wide parking spaces and ramps (see <i>Official Plan policy 4.3.10</i>)	<input checked="" type="checkbox"/>
REQUIRED	1.2.5 Include adequately spaced inter-block/street cycling and pedestrian connections to facilitate travel by active transportation. Provide links to the existing or planned network of public sidewalks, multi-use pathways and on-road cycle routes. Where public sidewalks and multi-use pathways intersect with roads, consider providing traffic control devices to give priority to cyclists and pedestrians (see <i>Official Plan policy 4.3.11</i>)	<input checked="" type="checkbox"/>
BASIC	1.2.6 Provide safe, direct and attractive walking routes from building entrances to nearby transit stops	<input checked="" type="checkbox"/>
BASIC	1.2.7 Ensure that walking routes to transit stops are secure, visible, lighted, shaded and wind-protected wherever possible	<input checked="" type="checkbox"/>
BASIC	1.2.8 Design roads used for access or circulation by cyclists using a target operating speed of no more than 30 km/h, or provide a separated cycling facility	<input type="checkbox"/>
1.3 Amenities for walking & cycling		
BASIC	1.3.1 Provide lighting, landscaping and benches along walking and cycling routes between building entrances and streets, sidewalks and trails	<input type="checkbox"/>
BASIC	1.3.2 Provide wayfinding signage for site access (where required, e.g. when multiple buildings or entrances exist) and egress (where warranted, such as when directions to reach transit stops/stations, trails or other common destinations are not obvious)	<input type="checkbox"/>

TDM-supportive design & infrastructure measures: <i>Residential developments</i>		Check if completed & add descriptions, explanations or plan/drawing references
2. WALKING & CYCLING: END-OF-TRIP FACILITIES		
2.1 Bicycle parking		
REQUIRED	2.1.1 Provide bicycle parking in highly visible and lighted areas, sheltered from the weather wherever possible (see <i>Official Plan policy 4.3.6</i>)	<input checked="" type="checkbox"/>
REQUIRED	2.1.2 Provide the number of bicycle parking spaces specified for various land uses in different parts of Ottawa; provide convenient access to main entrances or well-used areas (see <i>Zoning By-law Section 111</i>)	<input checked="" type="checkbox"/>
REQUIRED	2.1.3 Ensure that bicycle parking spaces and access aisles meet minimum dimensions; that no more than 50% of spaces are vertical spaces; and that parking racks are securely anchored (see <i>Zoning By-law Section 111</i>)	<input checked="" type="checkbox"/>
BASIC	2.1.4 Provide bicycle parking spaces equivalent to the expected number of resident-owned bicycles, plus the expected peak number of visitor cyclists	<input type="checkbox"/>
2.2 Secure bicycle parking		
REQUIRED	2.2.1 Where more than 50 bicycle parking spaces are provided for a single residential building, locate at least 25% of spaces within a building/structure, a secure area (e.g. supervised parking lot or enclosure) or bicycle lockers (see <i>Zoning By-law Section 111</i>)	<input checked="" type="checkbox"/>
BETTER	2.2.2 Provide secure bicycle parking spaces equivalent to at least the number of units at condominiums or multi-family residential developments	<input type="checkbox"/>
2.3 Bicycle repair station		
BETTER	2.3.1 Provide a permanent bike repair station, with commonly used tools and an air pump, adjacent to the main bicycle parking area (or secure bicycle parking area, if provided)	<input type="checkbox"/>
3. TRANSIT		
3.1 Customer amenities		
BASIC	3.1.1 Provide shelters, lighting and benches at any on-site transit stops	<input type="checkbox"/>
BASIC	3.1.2 Where the site abuts an off-site transit stop and insufficient space exists for a transit shelter in the public right-of-way, protect land for a shelter and/or install a shelter	<input type="checkbox"/>
BETTER	3.1.3 Provide a secure and comfortable interior waiting area by integrating any on-site transit stops into the building	<input type="checkbox"/>

TDM-supportive design & infrastructure measures: <i>Residential developments</i>		Check if completed & add descriptions, explanations or plan/drawing references
4. RIDESHARING		
4.1 Pick-up & drop-off facilities		
BASIC	4.1.1 Provide a designated area for carpool drivers (plus taxis and ride-hailing services) to drop off or pick up passengers without using fire lanes or other no-stopping zones	<input type="checkbox"/>
5. CARSHARING & BIKESHARING		
5.1 Carshare parking spaces		
BETTER	5.1.1 Provide up to three carshare parking spaces in an R3, R4 or R5 Zone for specified residential uses (see <i>Zoning By-law Section 94</i>)	<input type="checkbox"/>
5.2 Bikeshare station location		
BETTER	5.2.1 Provide a designated bikeshare station area near a major building entrance, preferably lighted and sheltered with a direct walkway connection	<input type="checkbox"/>
6. PARKING		
6.1 Number of parking spaces		
REQUIRED	6.1.1 Do not provide more parking than permitted by zoning, nor less than required by zoning, unless a variance is being applied for	<input checked="" type="checkbox"/>
BASIC	6.1.2 Provide parking for long-term and short-term users that is consistent with mode share targets, considering the potential for visitors to use off-site public parking	<input type="checkbox"/>
BASIC	6.1.3 Where a site features more than one use, provide shared parking and reduce the cumulative number of parking spaces accordingly (see <i>Zoning By-law Section 104</i>)	<input type="checkbox"/>
BETTER	6.1.4 Reduce the minimum number of parking spaces required by zoning by one space for each 13 square metres of gross floor area provided as shower rooms, change rooms, locker rooms and other facilities for cyclists in conjunction with bicycle parking (see <i>Zoning By-law Section 111</i>)	<input type="checkbox"/>
6.2 Separate long-term & short-term parking areas		
BETTER	6.2.1 Provide separate areas for short-term and long-term parking (using signage or physical barriers) to permit access controls and simplify enforcement (i.e. to discourage residents from parking in visitor spaces, and vice versa)	<input type="checkbox"/>

TDM Measures Checklist:
Non-Residential Developments (office, institutional, retail or industrial)

Legend	
BASIC	The measure is generally feasible and effective, and in most cases would benefit the development and its users
BETTER	The measure could maximize support for users of sustainable modes, and optimize development performance
★	The measure is one of the most dependably effective tools to encourage the use of sustainable modes

TDM measures: <i>Non-residential developments</i>		Check if proposed & add descriptions
1. TDM PROGRAM MANAGEMENT		
1.1 Program coordinator		
BASIC ★	1.1.1 Designate an internal coordinator, or contract with an external coordinator	<input type="checkbox"/>
1.2 Travel surveys		
BETTER	1.2.1 Conduct periodic surveys to identify travel-related behaviours, attitudes, challenges and solutions, and to track progress	<input type="checkbox"/>
2. WALKING AND CYCLING		
2.1 Information on walking/cycling routes & destinations		
BASIC	2.1.1 Display local area maps with walking/cycling access routes and key destinations at major entrances	<input checked="" type="checkbox"/>
2.2 Bicycle skills training		
<i>Commuter travel</i>		
BETTER ★	2.2.1 Offer on-site cycling courses for commuters, or subsidize off-site courses	<input type="checkbox"/>
2.3 Valet bike parking		
<i>Visitor travel</i>		
BETTER	2.3.1 Offer secure valet bike parking during public events when demand exceeds fixed supply (e.g. for festivals, concerts, games)	<input type="checkbox"/>

TDM measures: <i>Non-residential developments</i>		Check if proposed & add descriptions
3. TRANSIT		
3.1 Transit information		
BASIC	3.1.1 Display relevant transit schedules and route maps at entrances	<input checked="" type="checkbox"/>
BASIC	3.1.2 Provide online links to OC Transpo and STO information	<input type="checkbox"/>
BETTER	3.1.3 Provide real-time arrival information display at entrances	<input type="checkbox"/>
3.2 Transit fare incentives		
<i>Commuter travel</i>		
BETTER	3.2.1 Offer preloaded PRESTO cards to encourage commuters to use transit	<input type="checkbox"/>
BETTER ★	3.2.2 Subsidize or reimburse monthly transit pass purchases by employees	<input type="checkbox"/>
<i>Visitor travel</i>		
BETTER	3.2.3 Arrange inclusion of same-day transit fare in price of tickets (e.g. for festivals, concerts, games)	<input type="checkbox"/>
3.3 Enhanced public transit service		
<i>Commuter travel</i>		
BETTER	3.3.1 Contract with OC Transpo to provide enhanced transit services (e.g. for shift changes, weekends)	<input type="checkbox"/>
<i>Visitor travel</i>		
BETTER	3.3.2 Contract with OC Transpo to provide enhanced transit services (e.g. for festivals, concerts, games)	<input type="checkbox"/>
3.4 Private transit service		
<i>Commuter travel</i>		
BETTER	3.4.1 Provide shuttle service when OC Transpo cannot offer sufficient quality or capacity to serve demand (e.g. for shift changes, weekends)	<input type="checkbox"/>
<i>Visitor travel</i>		
BETTER	3.4.2 Provide shuttle service when OC Transpo cannot offer sufficient quality or capacity to serve demand (e.g. for festivals, concerts, games)	<input type="checkbox"/>

TDM measures: <i>Non-residential developments</i>		Check if proposed & add descriptions
4. RIDESHARING		
4.1 Ridematching service		
<i>Commuter travel</i>		
BASIC ★	4.1.1 Provide a dedicated ridematching portal at OttawaRideMatch.com	<input type="checkbox"/>
4.2 Carpool parking price incentives		
<i>Commuter travel</i>		
BETTER	4.2.1 Provide discounts on parking costs for registered carpools	<input type="checkbox"/>
4.3 Vanpool service		
<i>Commuter travel</i>		
BETTER	4.3.1 Provide a vanpooling service for long-distance commuters	<input type="checkbox"/>
5. CARSHARING & BIKESHARING		
5.1 Bikeshare stations & memberships		
BETTER	5.1.1 Contract with provider to install on-site bikeshare station for use by commuters and visitors	<input type="checkbox"/>
<i>Commuter travel</i>		
BETTER	5.1.2 Provide employees with bikeshare memberships for local business travel	<input type="checkbox"/>
5.2 Carshare vehicles & memberships		
<i>Commuter travel</i>		
BETTER	5.2.1 Contract with provider to install on-site carshare vehicles and promote their use by tenants	<input type="checkbox"/>
BETTER	5.2.2 Provide employees with carshare memberships for local business travel	<input type="checkbox"/>
6. PARKING		
6.1 Priced parking		
<i>Commuter travel</i>		
BASIC ★	6.1.1 Charge for long-term parking (daily, weekly, monthly)	<input type="checkbox"/>
BASIC	6.1.2 Unbundle parking cost from lease rates at multi-tenant sites	<input type="checkbox"/>
<i>Visitor travel</i>		
BETTER	6.1.3 Charge for short-term parking (hourly)	<input type="checkbox"/>

TDM measures: <i>Non-residential developments</i>		Check if proposed & add descriptions
7. TDM MARKETING & COMMUNICATIONS		
7.1 Multimodal travel information		
<i>Commuter travel</i>		
BASIC	★ 7.1.1 Provide a multimodal travel option information package to new/relocating employees and students	<input checked="" type="checkbox"/>
<i>Visitor travel</i>		
BETTER	★ 7.1.2 Include multimodal travel option information in invitations or advertising that attract visitors or customers (e.g. for festivals, concerts, games)	<input type="checkbox"/>
7.2 Personalized trip planning		
<i>Commuter travel</i>		
BETTER	★ 7.2.1 Offer personalized trip planning to new/relocating employees	<input type="checkbox"/>
7.3 Promotions		
<i>Commuter travel</i>		
BETTER	7.3.1 Deliver promotions and incentives to maintain awareness, build understanding, and encourage trial of sustainable modes	<input type="checkbox"/>
8. OTHER INCENTIVES & AMENITIES		
8.1 Emergency ride home		
<i>Commuter travel</i>		
BETTER	★ 8.1.1 Provide emergency ride home service to non-driving commuters	<input type="checkbox"/>
8.2 Alternative work arrangements		
<i>Commuter travel</i>		
BASIC	★ 8.2.1 Encourage flexible work hours	<input type="checkbox"/>
BETTER	8.2.2 Encourage compressed workweeks	<input type="checkbox"/>
BETTER	★ 8.2.3 Encourage telework	<input type="checkbox"/>
8.3 Local business travel options		
<i>Commuter travel</i>		
BASIC	★ 8.3.1 Provide local business travel options that minimize the need for employees to bring a personal car to work	<input type="checkbox"/>
8.4 Commuter incentives		
<i>Commuter travel</i>		
BETTER	8.4.1 Offer employees a taxable, mode-neutral commuting allowance	<input type="checkbox"/>
8.5 On-site amenities		
<i>Commuter travel</i>		
BETTER	8.5.1 Provide on-site amenities/services to minimize mid-day or mid-commute errands	<input type="checkbox"/>

TDM Measures Checklist:
Residential Developments (multi-family, condominium or subdivision)

Legend	
BASIC	The measure is generally feasible and effective, and in most cases would benefit the development and its users
BETTER	The measure could maximize support for users of sustainable modes, and optimize development performance
★	The measure is one of the most dependably effective tools to encourage the use of sustainable modes

TDM measures: <i>Residential developments</i>		Check if proposed & add descriptions
1. TDM PROGRAM MANAGEMENT		
1.1 Program coordinator		
BASIC	★ 1.1.1 Designate an internal coordinator, or contract with an external coordinator	<input type="checkbox"/>
1.2 Travel surveys		
BETTER	1.2.1 Conduct periodic surveys to identify travel-related behaviours, attitudes, challenges and solutions, and to track progress	<input type="checkbox"/>
2. WALKING AND CYCLING		
2.1 Information on walking/cycling routes & destinations		
BASIC	2.1.1 Display local area maps with walking/cycling access routes and key destinations at major entrances (<i>multi-family, condominium</i>)	<input checked="" type="checkbox"/>
2.2 Bicycle skills training		
BETTER	2.2.1 Offer on-site cycling courses for residents, or subsidize off-site courses	<input type="checkbox"/>

TDM measures: Residential developments		Check if proposed & add descriptions
3. TRANSIT		
3.1 Transit information		
BASIC	3.1.1 Display relevant transit schedules and route maps at entrances (<i>multi-family, condominium</i>)	<input checked="" type="checkbox"/>
BETTER	3.1.2 Provide real-time arrival information display at entrances (<i>multi-family, condominium</i>)	<input type="checkbox"/>
3.2 Transit fare incentives		
BASIC ★	3.2.1 Offer PRESTO cards preloaded with one monthly transit pass on residence purchase/move-in, to encourage residents to use transit	<input type="checkbox"/>
BETTER	3.2.2 Offer at least one year of free monthly transit passes on residence purchase/move-in	<input type="checkbox"/>
3.3 Enhanced public transit service		
BETTER ★	3.3.1 Contract with OC Transpo to provide early transit services until regular services are warranted by occupancy levels (<i>subdivision</i>)	<input type="checkbox"/>
3.4 Private transit service		
BETTER	3.4.1 Provide shuttle service for seniors homes or lifestyle communities (e.g. scheduled mall or supermarket runs)	<input type="checkbox"/>
4. CARSHARING & BIKESHARING		
4.1 Bikeshare stations & memberships		
BETTER	4.1.1 Contract with provider to install on-site bikeshare station (<i>multi-family</i>)	<input type="checkbox"/>
BETTER	4.1.2 Provide residents with bikeshare memberships, either free or subsidized (<i>multi-family</i>)	<input type="checkbox"/>
4.2 Carshare vehicles & memberships		
BETTER	4.2.1 Contract with provider to install on-site carshare vehicles and promote their use by residents	<input type="checkbox"/>
BETTER	4.2.2 Provide residents with carshare memberships, either free or subsidized	<input type="checkbox"/>
5. PARKING		
5.1 Priced parking		
BASIC ★	5.1.1 Unbundle parking cost from purchase price (<i>condominium</i>)	<input type="checkbox"/>
BASIC ★	5.1.2 Unbundle parking cost from monthly rent (<i>multi-family</i>)	<input checked="" type="checkbox"/>

TDM measures: Residential developments		Check if proposed & add descriptions
6. TDM MARKETING & COMMUNICATIONS		
6.1 Multimodal travel information		
BASIC ★	6.1.1 Provide a multimodal travel option information package to new residents	<input checked="" type="checkbox"/>
6.2 Personalized trip planning		
BETTER ★	6.2.1 Offer personalized trip planning to new residents	<input type="checkbox"/>

Appendix M

Signage Plan

SLATER STREET

LAURIER AVE.

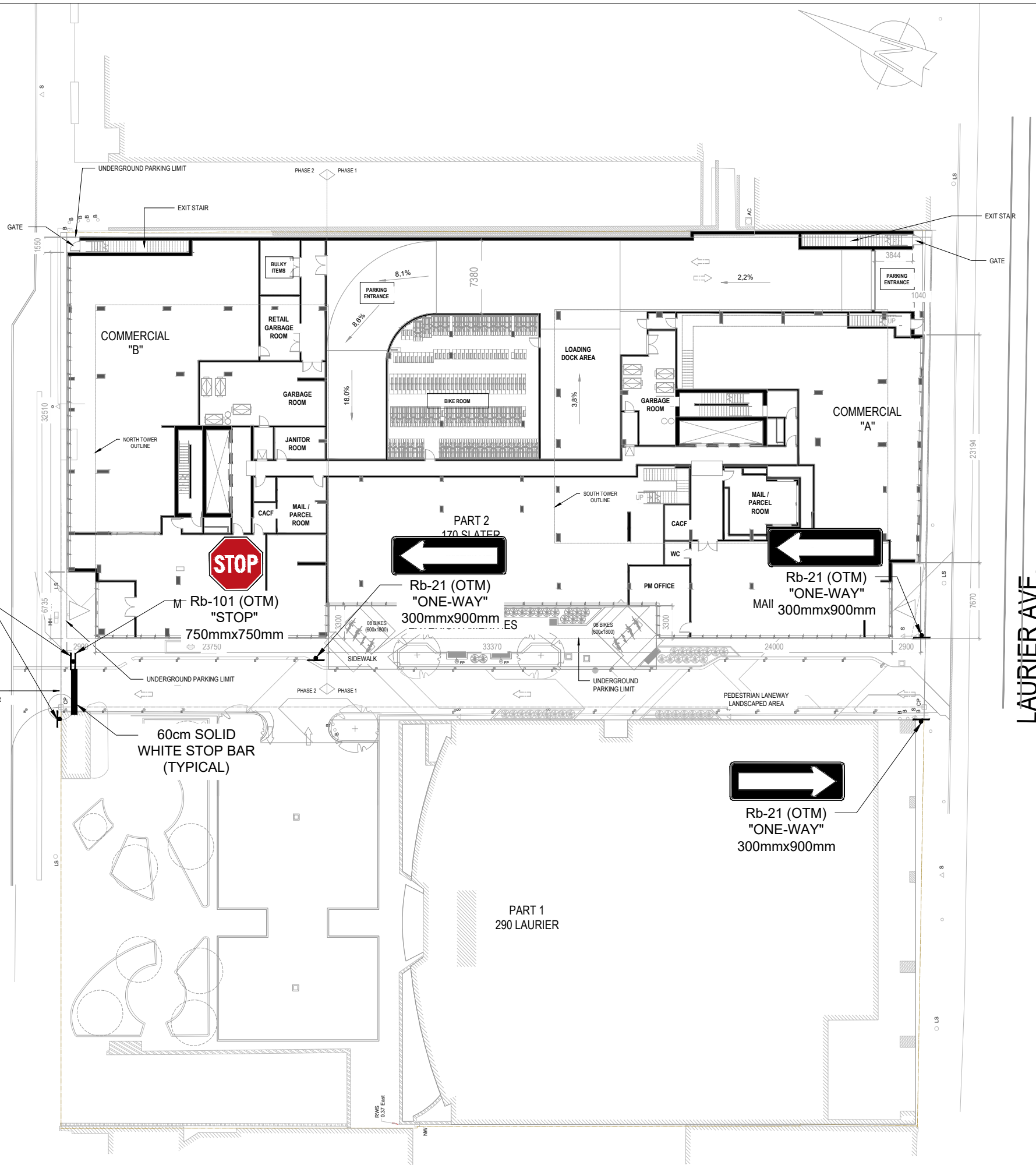

Rb-19 (OTM)
"DO NOT ENTER"
600mmx600mm

Rb-101 (OTM)
"STOP"
750mmx750mm

Rb-21 (OTM)
"ONE-WAY"
300mmx900mm ES

Rb-21 (OTM)
"ONE-WAY"
MAIL 300mmx900mm

Rb-21 (OTM)
"ONE-WAY"
300mmx900mm

60cm SOLID
WHITE STOP BAR
(TYPICAL)

Notes:

Key Map:

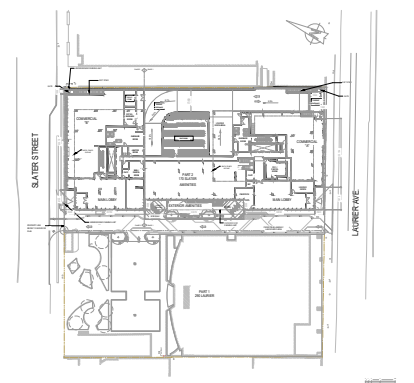

02	Updated Site Plan	AN	2023-07-07
01	Issued for Review	AN	2023-06-27
REV:	DESCRIPTION:	BY:	DATE:
STATUS:			

CGH Transportation
6 Plaza Court
Ottawa, ON
K2H 7W1
(343) 999-9117

CLIENT: **GWL Realty Advisors**
33 Yonge Street, Suite 1000
Toronto, ON M5E 1G4

ARCHITECT: **NEUF Architects**
630, boul. René-Lévesque O., 32e étages
Montréal QC H3B 1S6

SITE: 170 Slater St

TITLE: Signage Plan

SCALE AT A3: NTS	DATE: 2023-07-07	DRAWN: AN	CHECKED: MC
PROJECT NO: 2023-006	DRAWING NO: 001	REVISION: 02	



Appendix N

Turning Templates

HSU Inbound Movements

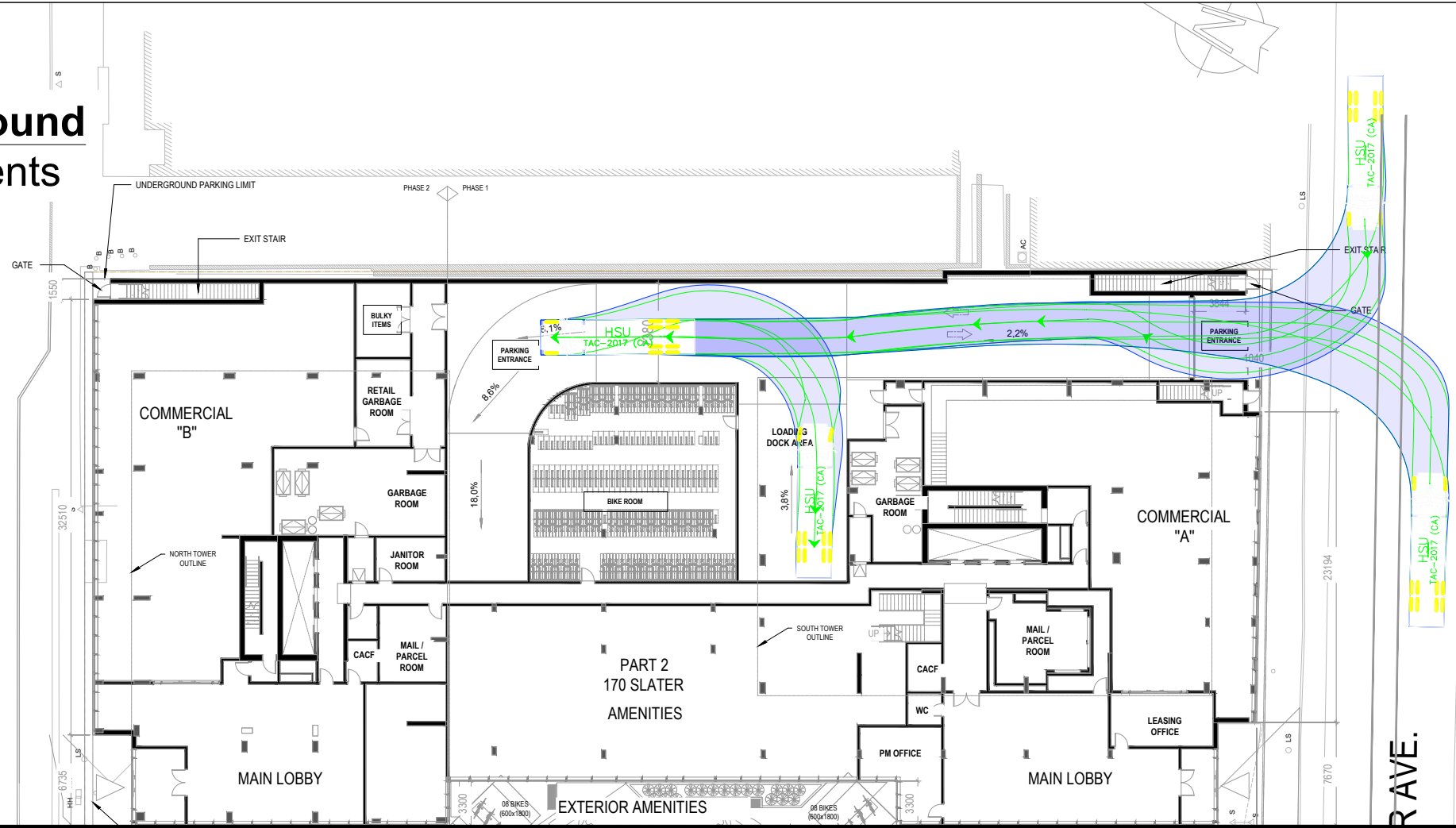

HSU Outbound Movements

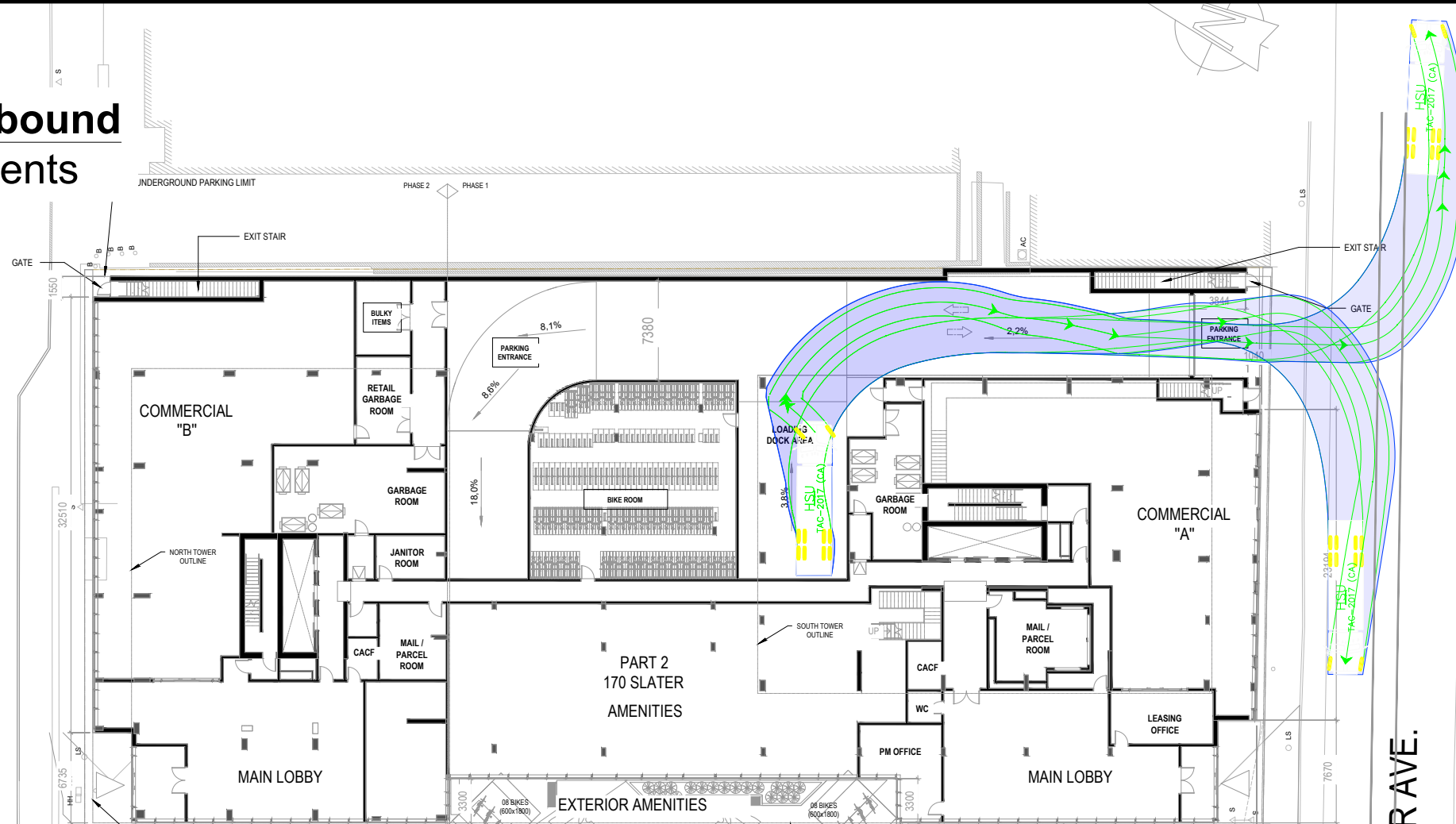

Notes:

Key Map:

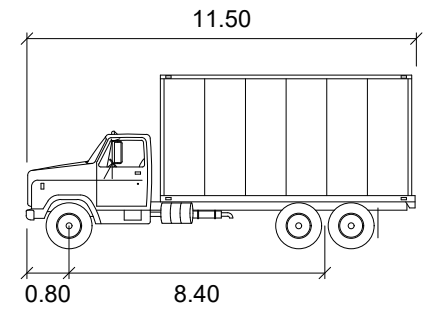
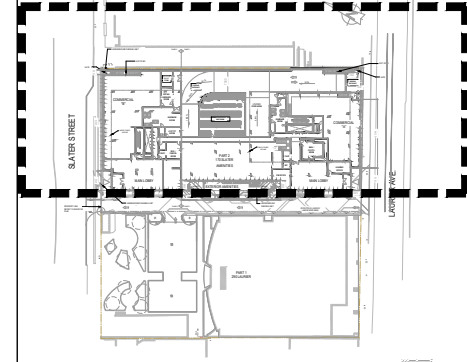

HSU

	meters
Width	: 2.60
Track	: 2.60
Lock to Lock Time	: 6.0
Steering Angle	: 40.0

02	Updated Site Plan	AN	2023-07-07
01	Issued for Review	AN	2023-06-27
REV:	DESCRIPTION:	BY:	DATE:
STATUS:			

CGH Transportation
 6 Plaza Court
 Ottawa, ON
 K2H 7W1
 (343) 999-9117

CLIENT: **GWL Realty Advisors**
 33 Yonge Street, Suite 1000
 Toronto, ON M5E 1G4

ARCHITECT: **NEUF Architect**
 630, boul. René-Lévesque O., 32e étages
 Montréal QC H3B 1S6

SITE: 170 Slater St

TITLE: **HSU Turning Movements
 Rear-end Movements**

SCALE AT A3:	DATE:	DRAWN:	CHECKED:
NTS	2023-07-07	AN	MC
PROJECT NO:	DRAWING NO:	REVISION:	
2023-006	001	02	

Appendix O

MMLOS Analysis

Multi-Modal Level of Service - Intersections Form

Consultant/ Scenario Comments	CGH Transportation	Project Date	2023-006
	Existing / Future		15-Jul-23

INTERSECTIONS		Slater St at Bank St				Slater St at R.O'Connor St				Laurier Ave at Bank St				Laurier Ave at R.O'Connor St			
Crossing Side		NORTH	SOUTH	EAST	WEST	NORTH	SOUTH	EAST	WEST	NORTH	SOUTH	EAST	WEST	NORTH	SOUTH	EAST	WEST
Pedestrian	Lanes	3	3	4	4	4	4	4	4	3	3	4	4	4	4	4	4
	Median	No Median - 2.4 m	No Median - 2.4 m	No Median - 2.4 m	No Median - 2.4 m	No Median - 2.4 m	No Median - 2.4 m	No Median - 2.4 m	No Median - 2.4 m	No Median - 2.4 m	No Median - 2.4 m	No Median - 2.4 m	No Median - 2.4 m	No Median - 2.4 m	No Median - 2.4 m	No Median - 2.4 m	No Median - 2.4 m
	Conflicting Left Turns	Protected/ Permissive	No left turn / Prohib.	No left turn / Prohib.	No left turn / Prohib.	No left turn / Prohib.	No left turn / Prohib.	Permissive	No left turn / Prohib.	No left turn / Prohib.	No left turn / Prohib.	No left turn / Prohib.	No left turn / Prohib.	No left turn / Prohib.	Protected/ Permissive	Permissive	No left turn / Prohib.
	Conflicting Right Turns	No right turn	Permissive or yield control	No right turn	No right turn	No right turn	Permissive or yield control	No right turn	No right turn	Permissive or yield control	Permissive or yield control	Permissive or yield control	Permissive or yield control	No right turn	Permissive or yield control	No right turn	Permissive or yield control
	Right Turns on Red (RTor)?	RTOR prohibited	RTOR prohibited	RTOR prohibited	RTOR prohibited	RTOR prohibited	RTOR prohibited	RTOR allowed	RTOR prohibited	RTOR prohibited	RTOR prohibited	RTOR prohibited	RTOR prohibited	RTOR prohibited	RTOR prohibited	RTOR prohibited	RTOR prohibited
	Ped Signal Leading Interval?	No	No	No	No	No	No	No	No	Yes	Yes	Yes	Yes	Yes	Yes	Yes	Yes
	Right Turn Channel	No Channel	No Channel	No Channel	No Channel	No Channel	No Channel	No Channel	No Channel	No Channel	No Channel	No Channel	No Channel	No Channel	No Channel	No Channel	No Channel
	Corner Radius	5-10m	5-10m	5-10m	5-10m	3-5m	3-5m	3-5m	3-5m	5-10m	3-5m	3-5m	5-10m	3-5m	5-10m	3-5m	3-5m
	Crosswalk Type	Std transverse markings	Std transverse markings	Std transverse markings	Std transverse markings	Std transverse markings	Std transverse markings	Std transverse markings	Std transverse markings	Std transverse markings	Std transverse markings	Std transverse markings	Std transverse markings	Std transverse markings	Std transverse markings	Std transverse markings	Std transverse markings
	PETSI Score	79	82	70	70	71	66	60	71	84	85	68	67	73	59	65	68
	Ped. Exposure to Traffic LoS	B	B	C	C	C	C	C	C	B	B	C	C	C	D	C	C
	Cycle Length	75	75		75	75			75	75	75	75	75	75		75	75
	Effective Walk Time	20	20		14	15			26	26	26	21	21	15		30	19
	Average Pedestrian Delay	20	20		25	24			16	16	16	19	19	24		14	21
Pedestrian Delay LoS	C	C	-	C	C	-	-	B	B	B	B	B	C	-	B	C	
Level of Service	C	C	C	C	C	C	C	C	B	B	C	C	C	D	C	C	
Approach From		C				C				C				D			
Bicycle	Bicycle Lane Arrangement on Approach	Mixed Traffic	Mixed Traffic		Mixed Traffic	Mixed Traffic			Mixed Traffic	Mixed Traffic	Mixed Traffic	Curb Bike Lane, Cycletrack or MUP	Curb Bike Lane, Cycletrack or MUP	Curb Bike Lane, Cycletrack or MUP	Curb Bike Lane, Cycletrack or MUP	Curb Bike Lane, Cycletrack or MUP	Curb Bike Lane, Cycletrack or MUP
	Right Turn Lane Configuration				> 50 m					≤ 50 m	> 50 m						
	Right Turning Speed				≤ 25 km/h					≤ 25 km/h	≤ 25 km/h						
	Cyclist relative to RT motorists	#N/A	#N/A	-	F	#N/A	-	-	#N/A	D	F	Not Applicable	Not Applicable	Not Applicable	Not Applicable	Not Applicable	Not Applicable
	Separated or Mixed Traffic	Mixed Traffic	Mixed Traffic	-	Mixed Traffic	Mixed Traffic	-	-	Mixed Traffic	Mixed Traffic	Mixed Traffic	Separated	Separated	Separated	Separated	Separated	Separated
	Left Turn Approach	≥ 2 lanes crossed			One lane crossed	≥ 2 lanes crossed				One lane crossed	One lane crossed	2-stage, LT box	2-stage, LT box	2-stage, LT box	2-stage, LT box	2-stage, LT box	2-stage, LT box
	Operating Speed	> 50 to < 60 km/h			> 50 to < 60 km/h	> 50 to < 60 km/h	F	-	-	> 50 to < 60 km/h	> 50 to < 60 km/h	> 50 to < 60 km/h	> 50 to < 60 km/h	> 50 to < 60 km/h	> 50 to < 60 km/h	> 50 to < 60 km/h	> 50 to < 60 km/h
Left Turning Cyclist	F	-	-	E	F	-	-	-	E	E	A	A	A	A	A	A	
Level of Service	#N/A	#N/A	-	F	#N/A	-	-	#N/A	E	F	A	A	A	A	A	A	
Average Signal Delay		#N/A				#N/A				F				A			
Transit	Average Signal Delay	≤ 30 sec	≤ 20 sec		≤ 20 sec					≤ 20 sec	≤ 20 sec						
	Level of Service	D	C	-	C	-	-	-	-	C	C	-	-	-	-	-	-
Truck	Effective Corner Radius								< 10 m	< 10 m	< 10 m	< 10 m	< 10 m	< 10 m			< 10 m
	Number of Receiving Lanes on Departure from Intersection								≥ 2	1	1	1	1	1			≥ 2
	Level of Service	-	-	-	-	-	-	-	D	F	F	F	F	F	-	-	D
Auto	Volume to Capacity Ratio		0.0 - 0.60					0.0 - 0.60				0.71 - 0.80				0.0 - 0.60	
	Level of Service		A					A				C				A	

Multi-Modal Level of Service - Segments Form

Consultant	CGH Transportation	Project	2023-006
Scenario	Existing / Future	Date	15-Jul-23
Comments			

SEGMENTS			Laurier Ave	Slater St	Section	
Pedestrian	Sidewalk Width	-	≥ 2 m	≥ 2 m	3	
	Boulevard Width		> 2 m	> 2 m		
	Avg Daily Curb Lane Traffic Volume		> 3000	> 3000		
	Operating Speed		> 50 to 60 km/h	> 50 to 60 km/h		
	On-Street Parking		yes	no		
	Exposure to Traffic PLoS		B	C		-
	Effective Sidewalk Width					
	Pedestrian Volume					
Crowding PLoS	-	-	-			
Level of Service	-	-	-			
Bicycle	Type of Cycling Facility	C	Physically Separated	Curbside Bike Lane		
	Number of Travel Lanes			≤ 1 each direction		
	Operating Speed			>50 to 70 km/h		
	# of Lanes & Operating Speed LoS		-	C	-	
	Bike Lane (+ Parking Lane) Width					
	Bike Lane Width LoS		-	-	-	
	Bike Lane Blockages					
	Blockage LoS		-	-	-	
	Median Refuge Width (no median = < 1.8 m)			< 1.8 m refuge		
	No. of Lanes at Unsignalized Crossing			≤ 3 lanes		
Sidestreet Operating Speed		>50 to 60 km/h				
Unsignalized Crossing - Lowest LoS	A	B	-			
Level of Service	A	C	-			
Transit	Facility Type	-				
	Friction or Ratio Transit:Posted Speed					
Level of Service	-	-	-			
Truck	Truck Lane Width	C	≤ 3.5 m	> 3.7 m		
	Travel Lanes per Direction		1	> 1		
	Level of Service		C	A	-	