

Edwards J. Cuhaci and Associates Architects Inc.

St. Patrick's Home Ottawa - New Construction

Stormwater Management Report

July 26, 2024

Restricted

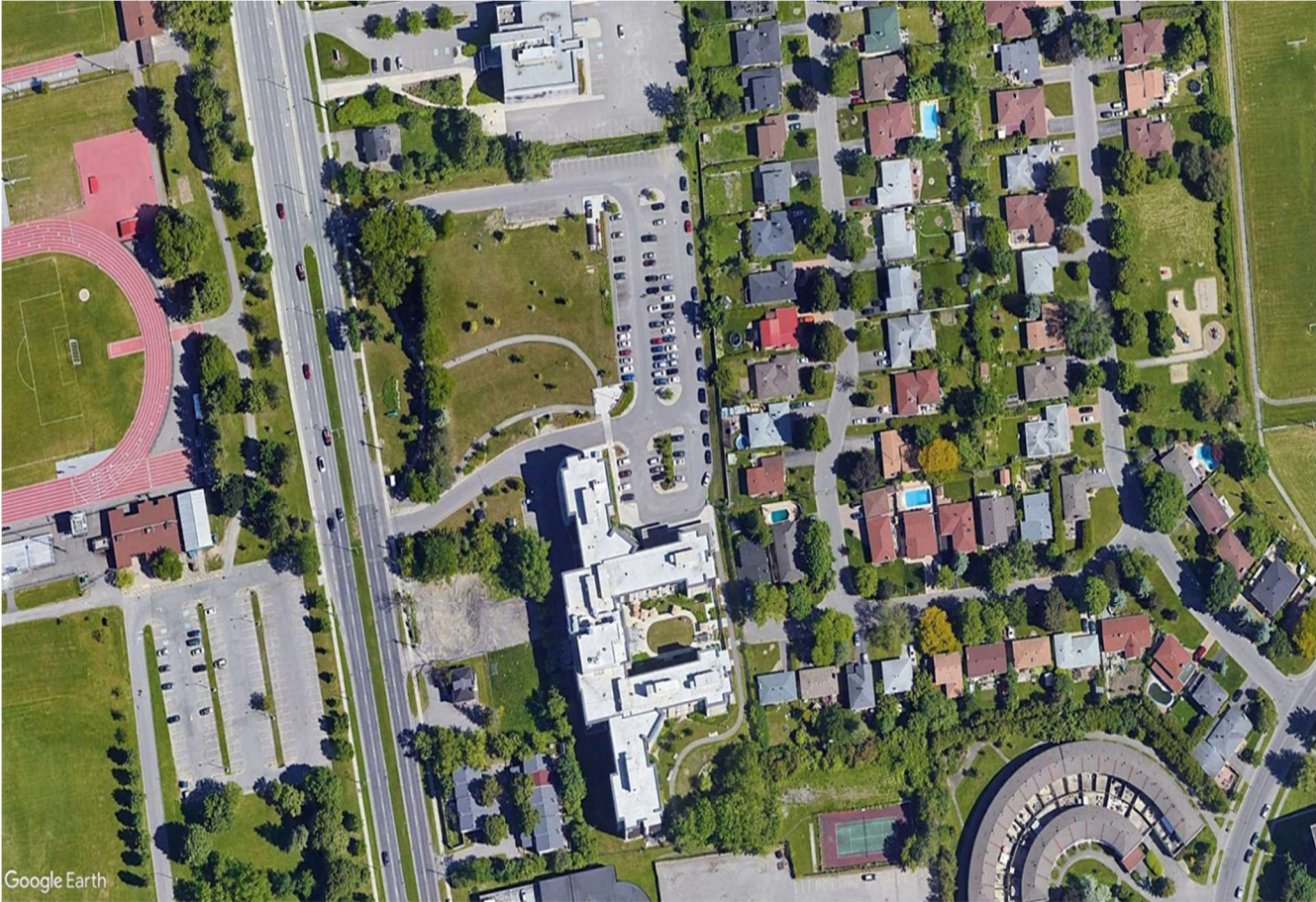

Google Earth





St. Patrick's Home Ottawa - New Construction

Stormwater Management Report

Edwards J. Cuhaci and Associates Architects Inc.
Restricted

Project No.: 221-08396-00

Date: July 26, 2024

WSP
201-1224 GARDINERS ROAD
KINGSTON, ON
CANADA K7P 0G2

T: +1 613 634-7373

F: +1 613 634-3523

wsp.com



July 26, 2024

Restricted

Edwards J. Cuhaci and Associates Architects Inc.
171 Slater Street, Suite 100,
Ottawa, ON K1P 5H7

Attention: David Bull

Dear Sir/Madam:

Subject: St. Patrick's Home Ottawa - New Construction Stormwater Management Report

We are pleased to submit one electronic copy of the FINAL Stormwater Management Report for the St. Patrick's Home Ottawa - New Construction. This report documents the stormwater management strategies for the new development.

We trust the submission of this documents meets your requirements. Should you have any comments we look forward to your response.

Sincerely,

A handwritten signature in black ink, appearing to read 'Bryan Orendorff'.

Bryan Orendorff
Manager, Water Resources

WSP ref.: 221-08396-00

Revision History

FIRST ISSUE

August 31, 2023	Issued for Site Plan Approval	
Prepared by	Reviewed by	Approved by
Marina St. Marseille Designer, Land Development and Municipal Engineering	Michael Flowers Engineer, Land Development and Municipal Engineering	Michael Flowers Engineer, Land Development and Municipal Engineering

REVISION 1

January 19, 2024	Issued for Site Plan Control Review	
Prepared by	Reviewed by	Approved by
Marina St. Marseille Designer, Land Development and Municipal Engineering	Michael Flowers Engineer, Land Development and Municipal Engineering	Michael Flowers Engineer, Land Development and Municipal Engineering

REVISION 2

April 26, 2024	Issued for Site Plan Control Review	
Prepared by	Reviewed by	Approved by
Marina St. Marseille Designer, Land Development and Municipal Engineering	Michael Flowers Engineer, Land Development and Municipal Engineering	Michael Flowers Engineer, Land Development and Municipal Engineering

REVISION 3

June 24, 2024	Issued for Site Plan Approval application	
Prepared by	Reviewed by	Approved by
Nupur Suthar Designer, Water Resources	Bryan Orendorff Manager, Water resources	Bryan Orendorff Manager, Water resources

REVISION 4

July 08, 2024	Issued for Final Site Plan Control	
Prepared by	Reviewed by	Approved by

Nupur Suthar Designer, Water Resources	Bryan Orendorff Manager, Water resources	Bryan Orendorff Manager, Water resources
FINAL		
July 26, 2024	Re-Issued for Final Site Plan Control	
Prepared by	Reviewed by	Approved by
Nupur Suthar Designer, Water Resources	Bryan Orendorff Manager, Water resources	Bryan Orendorff Manager, Water resources

Signatures

Prepared by

Nupur Suthar

2024-07-26

Nupur Suthar, E.I.T.
Designer, Water Resources

Date

Approved¹ by (must be reviewed for technical accuracy prior to approval)



Bryan Orendorff, P.Eng.
Manager, Water Resources

Date

WSP prepared this report solely for the use of the intended recipient, Edwards J. Cuhaci and Associates Architects Inc., in accordance with the professional services agreement. The intended recipient is solely responsible for the disclosure of any information contained in this report. The content and opinions contained in the present report are based on the observations and/or information available to WSP at the time of preparation. If a third party makes use of, relies on, or makes decisions in accordance with this report, said third party is solely responsible for such use, reliance or decisions. WSP does not accept responsibility for damages, if any, suffered by any third party as a result of decisions made or actions taken by said third party based on this report. This limitations statement is considered an integral part of this report.

The original of this digital file will be conserved by WSP for a period of not less than 10 years. As the digital file transmitted to the intended recipient is no longer under the control of WSP, its integrity cannot be assured. As such, WSP does not guarantee any modifications made to this digital file subsequent to its transmission to the intended recipient.

¹ Approval of this document is an administrative function indicating readiness for release and does not impart legal liability on to the Approver for any technical content contained herein. Technical accuracy and fit-for-purpose of this content is obtained through the review process. The Approver shall ensure the applicable review process has occurred prior to signing the document.

Contributors

Client

Edwards J. Cuhaci and Associates Architects
Inc.

David Bull

WSP

Designer, Water Resources
Engineer, Land Development and Municipal
Engineering
Project Manager, Water Resources
Overall Project Manager, Municipal

Nupur Suthar

Michael Flowers

Bryan Orendorff

Steve Davidson

Subconsultants

n/a



TABLE OF CONTENTS

1	INTRODUCTION.....	1
1.1	Scope	1
1.2	Site Location.....	1
1.3	Stormwater Management Criteria	2
2	PREDEVELOPMENT CONDITIONS	3
2.1	General	3
2.2	Allowable Flow Rates	3
3	POST DEVELOPMENT CONDITIONS.....	5
3.1	General	5
3.2	Peak Flow Targets.....	5
3.3	PCSWMM Modelling	5
3.3.1	Rainfall Data	6
3.3.2	Subcatchments	6
3.3.3	Junctions and Conduits	8
3.3.4	Storages	8
3.4	Water Quantity Control	8
3.4.1	Parking Lot Storage	8
3.4.2	Rooftop Storage.....	9
3.4.3	Drainage to Riverside Drive	10
3.4.4	Drainage to Garner Avenue	10
3.4.5	Stress Test.....	11
3.5	Water Quality Control	11
4	CONCLUSIONS.....	12
	BIBLIOGRAPHY	13

Tables

Table 2-1 Allowable Flow Rates.....	4
Table 3-1 Infiltration Parameters.....	6
Table 3-2 Subcatchment Parameters.....	7
Table 3-3 Peak Runoff from Uncontrolled Subcatchments.....	7
Table 3-4 Available Surface Storage.....	8
Table 3-5 Structure Storage Summary for 5-yr Return Period.....	9
Table 3-6 Structure Storage Summary for 100-yr Return Period	9
Table 3-7 Rooftop Storage Summary	10
Table 3-8 Summary of Uncontrolled Flows	10
Table 3-9 Comparison of Peak Flow Targets and Outflows to Garner Avenue	10
Table 3-10 Stress Test Summary for Structures	11

Figures

Figure 1 Site Location	1
------------------------------	---

Appendices

A	Civil drawings
B	General Plan of Services – Novatech 2011
C	Pre-Development Drainage Area Plan
D	Post-Development Drainage Area Plan
E	PCSWMM Model
E-1	PCSWMM Model Schematics
E-2	PCSWMM Model Parameters
E-3	PCSWMM Storage Summary
E-4	PCSWMM Model Output Files
F	Roof Drain Specifications
G	OGS Sizing Report

1 INTRODUCTION

1.1 Scope

WSP Canada Inc. (WSP) was retained by Edward J. Cuhaci and Associates and Architects Inc. to provide design consulting services for Stormwater Management Report for the proposed development of an apartment building at 2865 Riverside Drive in Ottawa, Ontario. This report addresses the quality and quantity of stormwater from pre-development to post-development conditions.

1.2 Site Location

The project site location is shown in **Figure 1**. It is approximately 1.65 hectares in size and is located on the east of Riverside Drive. The site is described as Part of Lots 45, 46, and Registered Plan 66 and Part of Lot 23 Junction Gore in the Geographic Township of Gloucester, City of Ottawa.

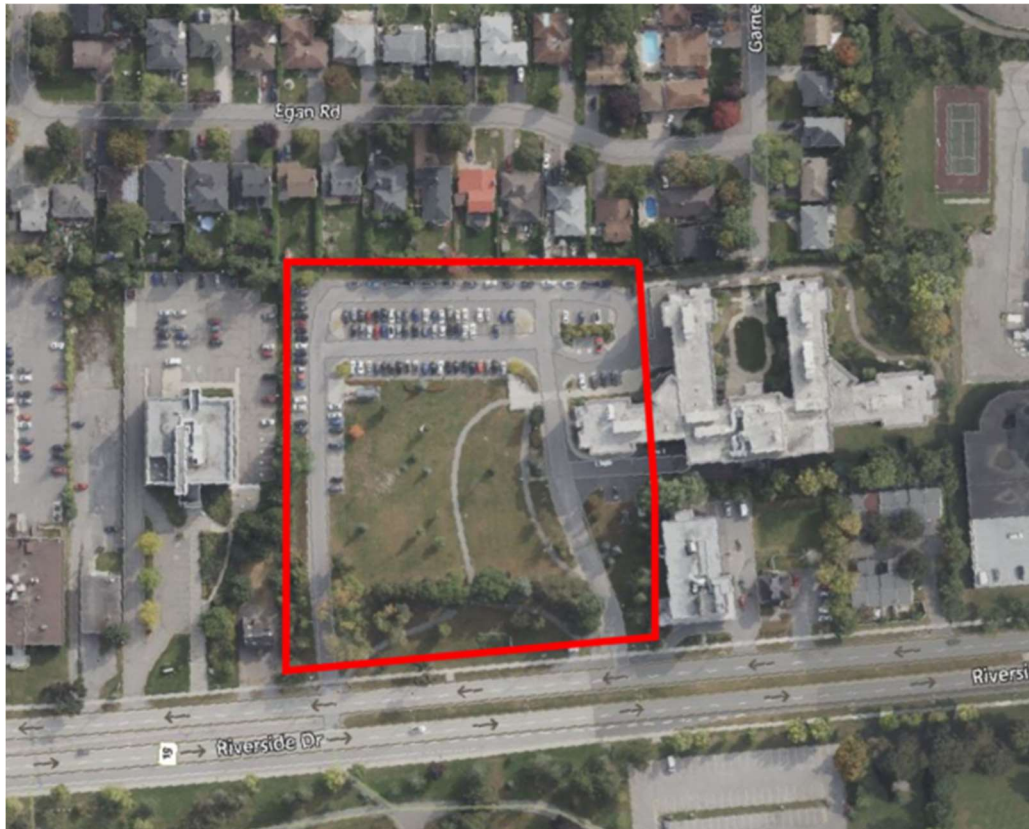

Figure 1 Site Location

The property is currently zoned 'Neighborhood' per the Official Plan, Schedule B3 Outer Urban Transect (November 2021). It is bound by residential properties to the east, the Canadian Labor Congress building to the north, St. Patrick's Home Long Term Care Facility to the south, and Riverside Drive to the west. The current site contains green space and is developed with an existing surface parking lot to the east with road access from Riverside Drive. There is also an asphalt walking pathway that connects a concrete walkway from the existing St. Patrick's Home to the concrete sidewalk along the Riverside Drive.

Refer to **Appendix A** for the Civil Drawings.

1.3 Stormwater Management Criteria

City of Ottawa Sewer Design Guidelines (October 2012) (the Guidelines) were reviewed, and the following stormwater management criteria have been adopted for the proposed site:

Quantity Control:

- Control post-development peak flows to Garner Avenue storm sewer system to pre-development levels of 76.1 L/s for all storms up to and including the 100-year storm.
- Control post-development peak flows to Riverside Drive to pre-development levels of 25 L/s for all storms up to and including the 100-year storm.

Quality Control:

- Enhanced Level 1 protection level, i.e., 80% long-term average removal of Total Suspended Solids (TSS).

2 PREDEVELOPMENT CONDITIONS

2.1 General

Pre-development conditions consists of an existing parking lot and landscaped area. An existing sidewalk accessible from Riverside Drive divides the project site in east and west areas. The site is surrounded by landscaped areas in the north and east corners and St. Patrick's Home Long Term Care Facility in the south corner.

Drainage from existing parking lot and landscaped area east of the sidewalk is captured by the catchbasins (CB) on site and conveyed to the existing 1500 mm diameter super pipe under the parking lot. Outflows from the super pipe are controlled by a 108 mm orifice plate. Uncontrolled drainage from north and east landscaped areas outlet to the Garner Avenue storm sewer system via landscape drains connected to the existing storm sewer system on site. Drainage from west of the sidewalk outlets directly on the Riverside Drive.

The general plan of services, describing most of the existing conditions on site per the latest site changes, was prepared by Novatech Engineering Consultants LTD as a part of the Stormwater Management Report (Novatech, 2011) for St. Patrick's Home and is included in **Appendix B**. Pre-development drainage area plan is included in **Appendix C**.

2.2 Allowable Flow Rates

As noted in the Novatech, 2011 report, the 100-yr allowable release rate from the combined proposed project site (north site) and existing St. Patrick's Home Long Term Care Facility (south site) is 104.6 L/s, referencing the capacity of the existing Garner Ave. storm sewer. The south site has a release rate of 28.5 L/s, as mentioned in the Novatech, 2011 report and confirmed by City of Ottawa on June 7, 2024. Existing outflows from the north site are to be controlled at 76.1 L/s.

Additionally, a small portion of the north site currently drains uncontrolled to Riverside Drive at a rate of 25 L/s which can be maintained as confirmed by the City of Ottawa on June 7, 2024. **Table 2-1** notes the allowable flow rates from the north site, south site and onto Riverside Drive.

Table 2-1 Allowable Flow Rates

Return Period	Garner Avenue storm sewer system (L/s)	St. Patrick's Home Long Term Care Facility (L/s)	Proposed North Site (L/s)	Overland to Riverside Drive (L/s)
5-yr	104.6	24.4	80.2	25
100-yr	104.6	28.5	76.1	25

3 POST DEVELOPMENT CONDITIONS

3.1 General

Drainage area delineation was conducted to determine the drainage pattern of the site under post-development conditions. The post-development drainage area plan is illustrated in **Appendix D**. Generally, existing drainage patterns have been maintained in the proposed conditions. Existing grading has been maintained for the landscaped area located west of the sidewalk. Therefore, this area will drain overland and uncontrolled to Riverside Drive. Landscaped areas in the north and east corners of the site have been maintained to outlet in the same manner as existing conditions, i.e., landscape drains to storm sewers on site and ultimately to the Garner Avenue storm sewer system.

The parking lot is proposed to have two new CBs and CB leads that collect and convey flows from the parking lot to the existing 1500 mm diameter super pipe. The super pipe attenuates and discharges flows at a controlled rate via a 50 mm diameter orifice at the existing maintenance hole (MH) 103. An Oil & Grit Separator (OGS) is proposed downstream of the control maintenance hole. The OGS will treat the outflows from super pipe to achieve 80% TSS removal before being discharged to the existing storm sewer system at Garner Avenue. Controlled outflow from the proposed building roof is considered to have no debris and will by-pass the OGS to connect to the existing storm sewer system at Garner Avenue.

3.2 Peak Flow Targets

Post-development peak flows from the proposed north site along with the uncontrolled flows from landscaped areas in the north, east and west corners of the site must be controlled down to the allowable release rates for each area. Novatech, 2011 report mentions the release rate from north and east landscaped areas to be 35.5 L/s, which has also been confirmed by the City.

Table 2-1 notes the peak flow targets from different areas of the proposed site.

3.3 PCSWMM Modelling

The modelling software utilized for the assessment was PCSWMM by Computational Hydraulics International (CHI) using PCSWMM version 5.2.4.

3.3.1 Rainfall Data

As per Ottawa Sewer Design Guidelines, a Chicago 3 hr distribution was used for this site. Rainfall intensities for the 100-yr storm with 10-minute time step have been maintained from the Guidelines. The following equation has been used to calculate rainfall intensities for the 5-yr storm with a 10-minute time step:

$$\text{5-yr intensity} = 998.071 / (\text{Time in min} + 6.053)^{0.814}$$

3.3.2 Subcatchments

The entire site was delineated in 18 subcatchments including north and south site. South site catchment areas have been included for completeness to ensure no loss of total drainage area from the property, but they discharge directly to outlets since they are not considered in the peak flow targets. A schematic of PCSWMM model is included in **Appendix E**. Horton method infiltration parameters have been applied to all the subcatchments as per the Guidelines as noted in **Table 3-1** below.

Table 3-1 Infiltration Parameters

Parameter	Unit	Value
Maximum Infiltration Rate	mm/hr	76.2
Minimum Infiltration Rate	mm/hr	13.2
Decay Constant	1/hr	4.14
N Imperv	-	0.013
N Perv	-	0.25
Dstore Imperv	mm	1.57
Dstore Perv	mm	4.67

The width for all the subcatchments has been maintained equal to twice the length of the street segment, as required in the Guidelines. The per cent imperviousness of each subcatchment area has been calculated by dividing the impervious area of each subcatchment by the total subcatchment area. Slope of each subcatchment area is based on the existing and proposed slopes with average slopes in impervious areas generally being equal to or less than 1 per cent.

Subcatchment area A2 consisting of the north and east landscaped areas and a portion of the south site has been divided into five subcatchment areas for modelling purposes (one for each inlet) as compared to the storm drainage area plan. Subcatchments A-3Ex and A-4Ex are part of the south site and they discharge directly to outlets since they are not considered in the peak flow targets. Subcatchment A1 represents the uncontrolled area draining overland to Riverside Drive. Subcatchment A5-Roof has

been modelled to represent the proposed building roof. **Table 3-2** represents individual subcatchment parameters used for this modelling exercise.

Table 3-2 Subcatchment Parameters

Name	Area (ha)	Runoff Coefficient 5-yr	Width (m)	Flow Length (m)	Slope (%)	Imperv. (%)
A1	0.15	0.29	55.19	27.54	0.74	13.15
A2*	0.26	0.33	-	-	-	-
A2_1	0.06	0.33	35.17	17	0.64	1
A2_2	0.02	0.33	19.50	10	0.64	1
A2_3	0.13	0.33	51.68	25	0.64	36.87
A2_4	0.04	0.33	30.79	14	0.64	1
A2_5	0.01	0.33	15.37	8	0.64	1
A-3Ex	0.27	0.23	73.89	36	0.50	25
A-4EX	0.35	0.90	84.05	42	0.50	25
A5-1	0.12	0.89	48.62	24.27	1	96.60
A5-2	0.09	0.90	44.76	21	1	100
A5-3	0.21	0.81	66.44	32	1	83.01
A5-4	0.11	0.82	45.65	23	1	86.67
A5-5	0.07	0.75	40.53	19	1	75.03
A5-6	0.09	0.90	42.86	21	1	100
A5-7	0.16	0.56	58.21	28	0.96	51.53
A5-8	0.10	0.44	45.22	23	0.96	33.65
A5-9	0.29	0.68	76.84	38	0.87	65.09
A5-B-Roof	0.14	0.90	54.23	26	1	100

*Area size of A2 is the sum of areas A2_1 to A2_5

Table 3-3 notes the peak runoff from uncontrolled subcatchments.

Table 3-3 Peak Runoff from Uncontrolled Subcatchments

Subcatchment ID	5-yr Peak Runoff (L/s)	100-yr Peak Runoff (L/s)
A1	10	10
A2_1	0	10
A2_2	0	10
A2_3	10	40
A2_4	0	10
A2_5	0	0

3.3.3 Junctions and Conduits

All the CBs and MHs have been modelled as junctions. CB leads and storm sewers have been modelled as conduits. Inverts and rim elevations of all the junctions and conduits have been maintained from the site servicing plan attached in **Appendix A** drawing sheet C5. The 1500 mm diameter super pipe has been divided into multiple segments to connect the CB leads into it. Inverts and rim elevations of these conduits have been interpolated in the model.

3.3.4 Storages

All the CBs and roof drains have been modelled to have storage to allow for surface ponding based on the proposed grading plan and roof drainage plan included in **Appendix A** drawing sheet C4 and M-311, respectively. **Table 3-4** notes the maximum ponding depth and ponding area available for parking lot structures and rooftop storage.

Table 3-4 Available Surface Storage

Area	Structure ID	Ponding depth Available (m)	Ponding Area Available (m ²)	Storage Volume Available (m ³)
A5-B Roof	-	0.15	1265	63
A5-1	EX CB 3	0.35	970	113
A5-2	EX CBMH 2	0.34	674	76
A5-3	EX CB 4	0.25	300	25
A5-4	EX CBMH 1	0.33	500	55
A5-5	CB 201	0.30	366	37
A5-6	CB 202	0.20	140	9
A5-7	EX CB 1	0.27	436	39
A5-8	LD's	-	-	-
A5-9	EX CBMH 3	0.35	830	100

Detailed PCSWMM model parameters are included in **Appendix E**.

3.4 Water Quantity Control

3.4.1 Parking Lot Storage

The minor system is designed to convey the runoff for events up to 5-yr return period. Major system runoff in excess of 5-yr and up to 100-yr must be stored on site as per the Guidelines. Parking lot storage with a ponding depth of up to 300 mm is permitted as per the Guidelines. The hydraulic grade line (HGL) analysis was completed using

PCSWMM. **Table 3-5** and **Table 3-6** provides a summary of storage used for a storm with 5-yr and 100-yr return period during HGL analysis.

Table 3-5 Structure Storage Summary for 5-yr Return Period

Structure	Maximum Utilized Storage (m ³)	Maximum Depth of Ponding (m)	Highest Ponding Elevation (m)	Structure Top of Grate Elevation (m)
EX CB 3	49	0.19	80.04	79.85
EX CBMH 2	40	0.20	80.06	79.86
EX CB 4	46	0.28	80.23	79.95
EX CBMH 1	40	0.23	80.10	79.87
CB 201	26	0.21	80.11	79.90
CB 202	0	0.03	80.13	80.10
EX CB 1	40	0.22	80.15	79.93
EX CBMH 3	2	0.04	80.64	80.60

Table 3-6 Structure Storage Summary for 100-yr Return Period

Structure	Maximum Utilized Storage (m ³)	Maximum Depth of Ponding (m)	Highest Ponding Elevation (m)	Structure Top of Grate Elevation (m)
EX CB 3	83	0.25	80.10	79.85
EX CBMH 2	68	0.26	80.12	79.86
EX CB 4	55	0.30	80.25	79.95
EX CBMH 1	70	0.30	80.17	79.87
CB 201	47	0.28	80.18	79.90
CB 202	1	0.04	80.14	80.10
EX CB 1	66	0.29	80.22	79.93
EX CBMH 3	5	0.06	80.66	80.60

3.4.2 Rooftop Storage

Proposed building will be equipped with 8 roof drains to store and convey runoff to the storm sewer system. Eight roof drains have been modelled, each with a maximum release rate of 1.5 L/s, as a single storage node for modelling purposes. This is selected based on a maximum of 150 mm of ponding depth and available manufacturer database. Watts RD 300 (half exposed) roof drains with adjustable flow control weirs is selected and included in **Appendix F**. A 200 mm diameter orifice is provided to simulate

the controlled release of outflow to the proposed storm sewer system. **Table 3-7** provides a summary of rooftop storage utilized for the proposed site.

Table 3-7 Rooftop Storage Summary

Return Period	Utilized Rooftop Storage Volume (m ³)	Maximum Depth of Ponding (m)	Total Outflow from Roof (L/s)
5-yr	33	0.09	8
100-yr	56	0.12	12

3.4.3 Drainage to Riverside Drive

The landscaped area west of the sidewalk in the proposed north site drains overland to Riverside Drive. **Table 3-8** shows the peak flow targets and 5-yr and 100-yr peak flows from this area.

Table 3-8 Summary of Uncontrolled Flows

Area	Peak Flow Targets (L/s)		Post-development Peak Flows (L/s)	
	5-yr	100-yr	5-yr	100-yr
A1 - West landscaped area	25	25	5	10

3.4.4 Drainage to Garner Avenue

In order to meet the additional storage requirements for the proposed development on site, roof storage was added to the site. Additionally, surface storage capacity was enhanced, and the outlet control device size was reduced to promote greater storage in the combined surface and sub-surface stormwater storage system.

Table 3-9 shows a comparison of allowable peak flows and outflows from the proposed north site to the storm sewer on Garner Ave.

Table 3-9 Comparison of Peak Flow Targets and Outflows to Garner Avenue

North Site	Peak Flow Targets (L/s)	Post-development Peak Flows (L/s)
5-yr	80.2	24
100-yr	76.1	67

As shown in **Table 3-9**, the release rates from the site have been met.

3.4.5 Stress Test

A climate change consideration of 20 per cent increase to 100-yr rainfall values has been applied to stress test the hydraulic performance of the proposed site as mentioned in the Guidelines. A summary of results of stress test of all the structures is listed in **Table 3-10** below. As shown, the maximum storage depth is less than 0.35 m under this stress test condition.

Table 3-10 Stress Test Summary for Structures

Structure	Maximum Storage (m ³)	Maximum Depth of Ponding (m)	Highest Ponding Elevation (m)	Structure Top of Grate Elevation (m)
EX CB 3	100	0.27	80.12	79.85
EX CBMH 2	81	0.29	80.15	79.86
EX CB 4	58	0.31	80.26	79.95
EX CBMH 1	84	0.33	80.20	79.87
CB 201	57	0.31	80.21	79.9
CB 202	1	0.05	80.15	80.10
EX CB 1	71	0.30	80.23	79.93
EX CBMH 3	13	0.11	80.71	80.60

3.5 Water Quality Control

An OGS unit has been proposed downstream of the storage control maintenance hole (Ex.MH 103) to achieve Enhanced Level 1 protection level, i.e., 80% long-term average removal of Total Suspended Solids (TSS). Imbrium Systems Stormceptor EFO4 model with an estimated net annual TSS reduction of 81% is proposed to achieve this criterion. This model treats a drainage area of 1.25 ha with 74.40 per cent imperviousness which represents the proposed paved subcatchment areas A5-1 to A5-9 including the landscaped areas in subcatchment A5-8. OGS sizing report and details are included in **Appendix G**. As mentioned in **Section 3.1**, outflows from the proposed building roof is considered to be clean and will by-pass the OGS to connect to the existing storm sewer system at Garner Avenue. OGS is proposed to treat the previously untreated paved areas.

4 CONCLUSIONS

WSP was retained by Edwards J. Cuhaci and Associates Architects Inc. to provide design consulting services for the proposed apartment building at St. Patrick's Homes located in Ottawa, Ontario. A stormwater management report has been prepared in support of the proposed development. An existing superpipe and storm sewer system in conjunction with two new catchbasins will provide quantity control for this development.

Water Quantity

Runoff from the proposed development will be controlled by the rooftop and parking lot storage in addition with surcharging an existing 1500 mm diameter super pipe under the existing parking lot. A total of 624 m³ of combined storage has been utilized. Post-development flows for 5-yr and 100-yr return periods have been controlled to below 76.1 L/s in compliance with the target release rates. Uncontrolled flow on Riverside Drive is maintained to below 25 L/s.

Water Quality

A Stormceptor EFO4 Oil and Grit Separator unit will provide 80% TSS removal efficiency.

BIBLIOGRAPHY

- Butcher, G. A. (1992, August 25). Ambient Water Quality Objectives for the Lower Columbia River: Hugh Keenleyside Dam to Birchbank. Retrieved December 4, 2013, from Environmental Protection Division:
<http://www.env.gov.bc.ca/wat/wq/objectives/birchbank/birchbank.html>
- Columbia Basin Trust. (2012, September). Climate Change, Impacts and Adaptation in the Canadian Columbia Basin: From Dialogue to Action. British Columbia, Canada.
- Holms, G. B., Pommen, L. W., & Cf, P. (1999, September). State of Water Quality of Columbia River at Birchbank . Retrieved December 4, 2013, from State of Water Quality of Columbia River at Birchbank :
<http://www.env.gov.bc.ca/wat/wq/quality/birchbank/index.htm>
- Ministry of Forests. (1996). Community Watershed Guidebook. Retrieved December 4, 2013, from Community Watershed Guidebook:
<http://www.for.gov.bc.ca/TASB/LEGSREGS/FPC/FPCGUIDE/WATRSBED/Watertoc.htm>

APPENDIX

A

Civil drawings



GENERAL

- DRAWINGS TO BE READ IN CONJUNCTION WITH ARCHITECTURAL AND LANDSCAPE DRAWINGS.
- ALL SERVICES, MATERIALS, CONSTRUCTION METHODS AND INSTALLATIONS SHALL BE IN ACCORDANCE WITH THE LATEST STANDARDS AND REGULATIONS OF THE: CITY OF OTTAWA STANDARD SPECIFICATIONS AND DRAWINGS, ONTARIO PROVINCIAL SPECIFICATION STANDARD SPECIFICATION (OPSS) AND ONTARIO PROVINCIAL STANDARD DRAWINGS (OPSD), UNLESS OTHERWISE SPECIFIED, TO THE SATISFACTION OF THE CITY AND THE CONSULTANT.
- THE POSITION OF EXISTING POLE LINES, CONDUITS, WATERMANS, SEWERS AND OTHER UNDERGROUND AND ABOVEGROUND UTILITIES, STRUCTURES AND APPURTENANCES IS NOT NECESSARILY SHOWN ON THE CONTRACT DRAWING, AND WHERE SHOWN, THE ACCURACY OF THE POSITION OF SUCH UTILITIES AND STRUCTURES IS NOT GUARANTEED. PRIOR TO CONSTRUCTION, THE CONTRACTOR SHALL SATISFY HIMSELF OF THE EXACT LOCATION OF ALL SUCH UTILITIES AND STRUCTURES, AND SHALL ASSUME ALL LIABILITY FOR DAMAGE TO THEM DURING THE COURSE OF CONSTRUCTION. ANY RELOCATION OF EXISTING UTILITIES REQUIRED BY THE DEVELOPMENT OF SUBJECT LANDS IS TO BE UNDERTAKEN AT CONTRACTOR'S EXPENSE.
- THE CONTRACTOR MUST NOTIFY ALL EXISTING UTILITY COMPANY OFFICIALS FIVE (5) BUSINESS DAYS PRIOR TO START OF CONSTRUCTION AND HAVE ALL EXISTING UTILITIES AND SERVICES LOCATED IN THE FIELD OR EXPOSED PRIOR TO THE START OF CONSTRUCTION, INCLUDING BUT NOT LIMITED TO HYDRO, BELL, CABLE TV, AND CONSUMERS GAS LINES.
- ALL TRENCHING AND EXCAVATIONS TO BE IN ACCORDANCE WITH THE LATEST REVISIONS OF THE OCCUPATIONAL HEALTH AND SAFETY ACT AND REGULATIONS FOR CONSTRUCTION PROJECTS. ALL INFORMATION SHALL BE CONFIRMED PRIOR TO COMMENCEMENT OF CONSTRUCTION.
- REFER TO ARCHITECTS PLANS FOR BUILDING DIMENSIONS, ELEVATIONS, LAYOUT AND REMOVALS. REFER TO LANDSCAPE PLAN FOR LANDSCAPED DETAILS AND OTHER RELEVANT INFORMATION. ALL INFORMATION SHALL BE CONFIRMED PRIOR TO COMMENCEMENT OF CONSTRUCTION.
- TOPOGRAPHIC SURVEY COMPLETED AND PROVIDED BY FARLEY, SMITH & DENIS SURVEYING LTD. DATED JUNE 7, 2023. CONTRACTOR TO VERIFY IN THE FIELD PRIOR TO CONSTRUCTION OF ANY WORK AND NOTIFY THE ENGINEER OF ANY DISCREPANCIES.
- ALL ELEVATIONS ARE GEODETIC AND UTILIZE METRIC UNITS. VERIFY THAT JOB BENCHMARKS HAVE NOT BEEN ALTERED OR DISTURBED.
- ALL GROUND SURFACES SHALL BE EVENLY GRADED WITHOUT PONDING AREAS AND WITHOUT LOW POINTS EXCEPT WHERE APPROVED SWALE OR DRAIN OUTLETS ARE PROVIDED.
- ALL EDGES OF DISTURBED PAVEMENT SHALL BE SAW CUT TO FORM A NEAT AND STRAIGHT LINE PRIOR TO PLACING NEW PAVEMENT. PAVEMENT REINSTATEMENT SHALL BE WITH STEP JOINTS OF 500mm WIDTH MINIMUM.
- ALL DISTURBED AREAS OUTSIDE PROPOSED GRADING LIMITS TO BE RESTORED TO ORIGINAL ELEVATIONS AND CONDITIONS UNLESS OTHERWISE SPECIFIED. EXISTING PARKING LOT SHALL BE RE-ASPHALTED AT EXISTING GRADES EXCEPT AS NOTED TO EVEN OUT GRADES. ALL RESTORATION SHALL BE COMPLETED WITH THE GEOTECHNICAL REQUIREMENTS FOR BACKFILL AND COMPACTION.
- ABUTTING PROPERTY GRADES TO BE MATCHED.
- CONTRACTOR SHALL OBTAIN AND PAY FOR ALL NECESSARY PERMITS AND APPROVALS FROM THE MUNICIPAL AUTHORITIES PRIOR TO COMMENCING CONSTRUCTION, INCLUDING WATER PERMIT AND ROAD CUT PERMIT.
- MINIMIZE DISTURBANCE TO EXISTING VEGETATION DURING THE EXECUTION OF ALL WORKS.
- REMOVE FROM SITE ALL EXCESS EXCAVATED MATERIAL UNLESS OTHERWISE DIRECTED FROM THE ENGINEER. EXCAVATE AND REMOVE ALL ORGANIC MATERIAL AND DEBRIS LOCATED WITHIN THE PROPOSED BUILDING, PARKING AND ROADWAY LOCATIONS.
- AT PROPOSED UTILITY CONNECTION POINTS AND CROSSINGS (I.E. STORM SEWER, SANITARY SEWER, WATER, ETC.) THE CONTRACTOR SHALL DETERMINE THE PRECISE LOCATION AND DEPTH OF EXISTING UTILITIES AND REPORT ANY DISCREPANCIES OR CONFLICTS TO THE ENGINEER BEFORE COMMENCING WORK.
- PRIOR TO CONSTRUCTION, A GEOTECHNICAL ENGINEER REGISTERED IN THE PROVINCE OF ONTARIO IS TO INSPECT ALL SUB-SURFACES FOR FOOTINGS, SERVICES AND PAVEMENT STRUCTURES.
- CONTRACTOR TO OBTAIN POST-CONSTRUCTION TOPOGRAPHIC SURVEY PERFORMED BY CERTIFIED OLS OR P.ENG. CONFIRMING COMPLIANCE WITH DESIGN GRADING AND SERVICING. SURVEY IS TO INCLUDE LOCATION AND INVERTS FOR BURIED UTILITIES.
- PROVIDE CCTV FOLLOWING RECTIFICATION OF ANY DEFICIENCIES.
- REPORT REFERENCES
 - ST. PATRICK'S HOME 2865 RIVERSIDE DRIVE STORMWATER MANAGEMENT REPORT, PREPARED BY NOVATECH, PROJ NO.R-2010-121, OCTOBER 29, 2010.
 - GEOTECHNICAL INVESTIGATION REPORT FOR ST. PATRICK'S HOME OF OTTAWA, PREPARED BY STANTEC, PROJ NO.121624271, OCTOBER 2022.
 - 2865 RIVERSIDE DRIVE - ADEQUACY OF PUBLIC SERVICES, PREPARED BY NOVATECH, APRIL 15, 2021.
 - ST. PATRICK'S HOME DEVELOPMENT SERVICING REPORT, PREPARED BY WSP, APRIL 26, 2024.
 - ST. PATRICK'S HOME DEVELOPMENT SWM REPORT, PREPARED BY WSP, JUNE 21, 2024.

PARKING LOT AND WORK IN PUBLIC RIGHTS OF WAY

- CONTRACTOR TO REINSTATE ROAD CUTS AS PER CITY OF OTTAWA DETAIL R10.
- GEOTECHNICAL INVESTIGATION REPORT - FOR ST. PATRICK'S HOME OF OTTAWA, PREPARED BY STANTEC, PROJ NO.121624271, OCTOBER 2022
- CONTRACTOR TO PREPARE SUBGRADE, INCLUDING PROOFROLLING, TO THE SATISFACTION OF THE GEOTECHNICAL CONSULTANT PRIOR TO THE COMMENCEMENT OF PLACEMENT OF GRANULAR B MATERIAL.
- FILL TO BE PLACED AND COMPACTED PER THE GEOTECHNICAL REPORT REQUIREMENTS.
- CONTRACTOR TO SUPPLY, PLACE AND COMPACT GRANULAR B MATERIAL IN ACCORDANCE WITH THE RECOMMENDATIONS OF THE GEOTECHNICAL CONSULTANT. CONTRACTOR TO PROVIDE CONSULTANT WITH SAMPLES OF GRANULAR B MATERIAL FOR TESTING AND CERTIFICATION FROM THE GEOTECHNICAL CONSULTANT THAT THE MATERIAL MEETS THE GRADATION REQUIREMENTS SPECIFIED IN THE GEOTECHNICAL REPORT.
- GRANULAR A MATERIAL TO BE PLACED ONLY UPON APPROVAL BY THE GEOTECHNICAL CONSULTANT OF GRANULAR B PLACEMENT.
- CONTRACTOR TO SUPPLY, PLACE AND COMPACT GRANULAR A MATERIAL IN ACCORDANCE WITH THE RECOMMENDATIONS OF THE GEOTECHNICAL CONSULTANT. CONTRACTOR TO PROVIDE CONSULTANT WITH SAMPLES OF GRANULAR A MATERIAL FOR TESTING AND CERTIFICATION FROM THE GEOTECHNICAL CONSULTANT THAT THE MATERIAL MEETS THE GRADATION REQUIREMENTS SPECIFIED IN THE GEOTECHNICAL REPORT.
- ASPHALT MATERIAL TO BE PLACED ONLY UPON APPROVAL BY THE GEOTECHNICAL CONSULTANT OF GRANULAR A PLACEMENT.
- CONTRACTOR TO SUPPLY, PLACE AND COMPACT ASPHALT MATERIAL IN ACCORDANCE WITH THE RECOMMENDATIONS OF THE GEOTECHNICAL CONSULTANT. CONTRACTOR TO PROVIDE CONSULTANT WITH SAMPLES OF ASPHALT MATERIAL FOR TESTING AND CERTIFICATION FROM THE GEOTECHNICAL CONSULTANT THAT THE MATERIAL MEETS THE REQUIREMENTS SPECIFIED IN THE GEOTECHNICAL REPORT.
- CONTRACTOR IS RESPONSIBLE FOR ESTABLISHING LINE AND GRADE IN ACCORDANCE WITH THE PLANS, AND FOR PROVIDING THE CONSULTANT WITH VERIFICATION PRIOR TO PLACEMENT.
- ALL EXCESS MATERIAL TO BE HAULED OFFSITE AND DISPOSED OF AT AN APPROVED DUMP SITE. SHOULD THE CONTRACTOR DISCOVER ANY HAZARDOUS MATERIAL, CONTRACTOR IS TO NOTIFY CONSULTANT. CONSULTANT TO DETERMINE APPROPRIATE DISPOSAL METHOD/LOCATION.
- PAVEMENT STRUCTURE (MATERIAL TYPES AND THICKNESS) TO BE AS SPECIFIED IN THE GEOTECHNICAL REPORT.

STORM SEWERS AND STRUCTURES

- ALL STORM SEWER MATERIALS AND CONSTRUCTION METHODS SHALL CONFORM TO THE CURRENT CITY OF OTTAWA STANDARDS AND SPECIFICATIONS. PROVIDE CCTV INSPECTION REPORTS FOR ALL NEW STORM SEWERS, SERVICES AND CB LEADS.
- STORM SEWERS 450mm DIAMETER AND SMALLER SHALL BE PVC SDR-35, WITH RUBBER GASKET PER CSA A-257.3.
- STORM SEWER LARGER THAN 450mm SHALL BE REINFORCED CONCRETE CLASS 100D.
- SEWER BEDDING AS PER CITY OF OTTAWA DETAIL S6.
- ALL STORM MANHOLES TO BE AS PER STORM STRUCTURE TABLE.
- ANY NEW OR EXISTING STORM SEWER WITH LESS THAN 2.0m COVER REQUIRES THERMAL INSULATION AS PER CITY OF OTTAWA STANDARD W22, OR APPROVED BY THE ENGINEER.
- ALL CATCHBASIN LEADS TO BE MINIMUM 200mm DIAMETER AT MINIMUM 1.0% SLOPE UNLESS OTHERWISE SPECIFIED.
- STORM CATCHBASINS AS PER OPSD 705.010 AND FRAME/COVER AS PER CITY STANDARD DRAWINGS S19. STORM CBMHS AS INDICATED IN TABLE WITH SUMP, ADJUSTMENT SECTIONS SHALL BE AS PER OPSD 704.010.
- INSTALLATION OF FLOW CONTROL ICDS TO BE VERIFIED BY QUALITY VERIFICATION ENGINEER RETAINED BY CONTRACTOR.
- PROVIDE BACKWATER VALVE ON FOUNDATION DRAIN, STORM DISCHARGE, AND OVERFLOW DISCHARGE PER S14
- ALL CATCHBASINS EXCLUDING LANDSCAPE CATCHBASINS TO HAVE 150 MMØ PERFORATED PIPE FOR 3.0M ON ALL AVAILABLE SIDES AT AN ELEVATION OF 300mm BELOW SUBGRADE LEVEL AS PER CITY OF OTTAWA STANDARD DRAWING 'R1'

SANITARY SEWER AND STRUCTURES

- ALL SANITARY SEWER, SANITARY SEWER APPURTENANCES AND CONSTRUCTION METHODS SHALL CONFORM TO THE CURRENT CITY OF OTTAWA STANDARDS AND SPECIFICATIONS. PROVIDE CCTV INSPECTION REPORTS FOR ALL NEW SANITARY PIPING.
- SANITARY SEWER PIPE SIZE 150mm DIAMETER AND GREATER TO BE PVC SDR-35 (UNLESS SPECIFIED OTHERWISE) WITH RUBBER GASKET TYPE JOINTS IN CONFORMANCE WITH CSA B-182.2.3.4.
- SEWER BEDDING AS PER CITY OF OTTAWA DETAIL S6.
- ALL SANITARY MANHOLES 1200mm IN DIAMETER TO BE AS PER OPSD 701.01. FRAME AND COVER TO BE AS PER CITY OF OTTAWA STANDARD S25 AND S24.
- MAINTENANCE HOLE BENCHING AND PIPE OPENING ALTERNATIVES AS PER THE OPSD 701.021
- ANY SANITARY SEWER WITH LESS THAN 2.0m COVER REQUIRES THERMAL INSULATION AS PER CITY OF OTTAWA STANDARD W22, OR APPROVED BY THE ENGINEER.
- PROVIDE BACKWATER VALVE FOR BUILDING SANITARY SERVICES PER S14.1

WATERMAIN

- ALL WATERMAIN AND WATERMAIN APPURTANANCES, MATERIALS, CONSTRUCTION AND TESTING METHODS SHALL CONFORM TO THE CURRENT CITY OF OTTAWA AND MINISTRY OF ENVIRONMENT STANDARDS AND SPECIFICATIONS.
- ALL WATERMAIN 300mm DIAMETER AND SMALLER TO BE POLY VINYL CHLORIDE (PVC) CLASS 150 DR 18 MEETING AWWA SPECIFICATION C900.
- ALL WATERMAIN TO BE INSTALLED AT MINIMUM COVER OF 2.4m BELOW FINISHED GRADE. WHERE WATERMANS CROSS OVER OTHER UTILITIES, A MINIMUM 0.30m CLEARANCE SHALL BE MAINTAINED; WHERE WATERMANS CROSS UNDER OTHER UTILITIES, A MINIMUM 0.50m CLEARANCE SHALL BE MAINTAINED. WHERE THE MINIMUM SEPARATION CANNOT BE ACHIEVED, THE WATERMAIN SHALL BE INSTALLED AS PER CITY OF OTTAWA STANDARDS W25 AND W25.2. WHERE 2.4m MINIMUM DEPTH CANNOT BE ACHIEVED, THERMAL INSULATION SHALL BE PROVIDED AS PER CITY OF OTTAWA STANDARD W22. WHERE A WATERMAIN IS IN CLOSE PROXIMITY TO AN OPEN STRUCTURE, THERMAL INSULATION SHALL BE PROVIDED AS PER CITY OF OTTAWA STANDARD W23.
- CONCRETE THRUST BLOCKS AND MECHANICAL RESTRAINTS ARE TO BE INSTALLED AT ALL TEES, BENDS, HYDRANTS, REDUCERS, ENDS OF MAINS AND CONNECTIONS 100mm AND LARGER, IN ACCORDANCE WITH CITY OF OTTAWA STANDARDS W25.3 & W25.4.
- CATHODIC PROTECTION REQUIRED FOR ALL IRON FITTINGS AS PER CITY OF OTTAWA STANDARD W40 & W42.
- ALL VALVES AND VALVE BOXES AND CHAMBERS, HYDRANTS, AND HYDRANT VALVES AND ASSEMBLES SHALL BE INSTALLED AS PER CITY OF OTTAWA STANDARD.
- FIRE HYDRANT LOCATION AND INSTALLATION AS PER CITY OF OTTAWA STANDARD W18 & W19. CONTRACTOR TO PROVIDE FLOW TEST AND PAINTING OF NEW HYDRANT IN ACCORDANCE WITH CITY STANDARDS.
- IF WATER MAIN MUST BE DEFLECTED TO MEET ALIGNMENT, ENSURE THAT THE AMOUNT OF DEFLECTION USED IS LESS THAN HALF THAT RECOMMENDED BY THE MANUFACTURER.

Recommended Pavement Structure

Location	Asphalt Thickness	Base Thickness OPSS Granular A (mm)	Subbase Thickness Granular B Type II (mm)
Standard Duty Parking Areas	60 mm SP12.5 mm	150	300
Heavy Duty Parking	40 mm SP12.5 mm 50 mm SP SP19.0 mm	150	400

EROSION AND SEDIMENT CONTROL

- ** CONTRACTOR IS RESPONSIBLE FOR ALL INSTALLATION, MONITORING, REPAIR AND REMOVAL OF ALL EROSION AND SEDIMENT CONTROL FEATURES. ****
- PRIOR TO START OF CONSTRUCTION:
 - INSTALL SILT FENCE IN LOCATION SHOWN.
 - INSTALL SILT SACK FILTERS IN ALL THE CATCHBASINS AND MANHOLES TO REMAIN DURING CONSTRUCTION WITHIN THE SITE.
 - INSPECT MEASURES IMMEDIATELY AFTER INSTALLATION.
 - INSTALL MUD MAT AT CONSTRUCTION ENTRANCES.
 - DURING CONSTRUCTION:
 - MINIMIZE THE EXTENT OF DISTURBED AREAS AND THE DURATION OF EXPOSURE AND IMPACTS TO EXISTING GRADING.
 - PERIMETER VEGETATION TO REMAIN IN PLACE UNTIL PERMANENT STORM WATER MANAGEMENT IS IN PLACE. OTHERWISE, IMMEDIATELY INSTALL SILT FENCE WHEN THE EXISTING SITE IS DISTURBED AT THE PERIMETER.
 - PROTECT DISTURBED AREAS FROM OVERLAND FLOW BY PROVIDING TEMPORARY SWALES TO THE SATISFACTION OF THE FIELD ENGINEER. TIE-IN TEMPORARY SWALE TO EXISTING CB'S AS REQUIRED.
 - PROVIDE TEMPORARY COVER SUCH AS SEEDING OR MULCHING IF DISTURBED AREA WILL NOT BE REHABILITATED WITHIN 30 DAYS.
 - INSPECT SILT FENCES, FILTER FABRIC FILTERS AND CATCH BASIN SUMPS WEEKLY AND WITHIN 24 HOURS AFTER A STORM EVENT. CLEAN AND REPAIR WHEN NECESSARY.
 - DOWNSTREAM STORM INFRASTRUCTURE SHALL BE PROTECTED FROM UNFILTERED RUNOFF DURING ON-SITE STORM INFRASTRUCTURE DEMOLITION.
 - DRAWING TO BE REVIEWED AND REVISED AS REQUIRED DURING CONSTRUCTION.
 - EROSION CONTROL FENCING TO BE ALSO INSTALLED AROUND THE BASE OF ALL STOCKPILES. DO NOT LOCATE TOPSOIL PILES AND EXCAVATION MATERIAL CLOSER THAN 2.5m FROM ANY PAVED SURFACE, OR ONE WHICH IS TO BE PAVED BEFORE THE PILE IS REMOVED. ALL TOPSOIL PILES ARE TO BE SEEDDED IF THEY ARE TO REMAIN ON SITE LONG ENOUGH FOR SEEDS TO GROW (LONGER THAN 30 DAYS).
 - CONTROL WIND-BLOWN DUST OFF SITE BY SEEDING TOPSOIL PILES AND OTHER AREAS TEMPORARILY (PROVIDE WATERING AS REQUIRED AND TO THE SATISFACTION OF THE ENGINEER).
 - NO ALTERNATE METHODS OF EROSION PROTECTION SHALL BE PERMITTED UNLESS APPROVED BY THE FIELD ENGINEER.
 - CITY ROADWAY AND SIDEWALK TO BE CLEANED OF ALL SEDIMENT FROM VEHICULAR TRACKING AS REQUIRED.
 - DURING WET CONDITIONS, TIRES OF ALL VEHICLES/EQUIPMENT LEAVING THE SITE ARE TO BE SCRAPPED.
 - ANY MUD/MATERIAL TRACKED ONTO THE ROAD SHALL BE REMOVED IMMEDIATELY BY HAND OR RUBBER TIRE LOADER.
 - TAKE ALL NECESSARY STEPS TO PREVENT BUILDING MATERIAL, CONSTRUCTION DEBRIS OR WASTE BEING SPILLED OR TRACKED ONTO ABUTTING PROPERTIES OR PUBLIC STREETS DURING CONSTRUCTION AND PROCEED IMMEDIATELY TO CLEAN UP ANY AREAS SO AFFECTED.
 - ALL EROSION CONTROL STRUCTURE TO REMAIN IN PLACE UNTIL ALL DISTURBED GROUND SURFACES HAVE BEEN STABILIZED EITHER BY PAVING OR RESTORATION OF VEGETATIVE GROUND COVER.
 - THE CONTRACTOR SHALL IMPLEMENT BEST MANAGEMENT PRACTICES, TO PROVIDE FOR PROTECTION OF THE AREA DRAINAGE SYSTEM AND THE RECEIVING WATERCOURSE, DURING CONSTRUCTION ACTIVITIES. THE CONTRACTOR ACKNOWLEDGES THAT FAILURE TO IMPLEMENT APPROPRIATE EROSION AND SEDIMENT CONTROL MEASURES MAY BE SUBJECT TO PENALTIES IMPOSED BY ANY APPLICABLE REGULATORY AGENCY.

EXISTING LEGEND:

- EXISTING CURB
- EXISTING BOTTOM OF SLOPE
- EXISTING TOP OF SLOPE
- MAJOR CONTOURS
- MINOR CONTOURS
- EXISTING OVERHEAD WIRE
- EXISTING GUY ANCHOR
- EXISTING WATERMAIN
- EXISTING STORM SEWER
- EXISTING SANITARY SEWER
- EXISTING GAS
- EXISTING UNDERGROUND
- EXISTING CABLE
- EXISTING SWALE
- EXISTING FENCE
- PROPERTY BOUNDARY
- SITE TEMPORARY BENCH MARK
- BOREHOLE LOCATION
- EXISTING UTILITY POLE
- EXISTING ROAD SIGN
- EXISTING CULVERT
- EXISTING ASPHALT PAVING
- EXISTING SIDEWALK
- EXISTING BUILDING
- EXISTING SANITARY MANHOLE
- EXISTING FIRE HYDRANT
- EXISTING WATER VALVE
- EXISTING ELEVATION
- BOREHOLE
- EXISTING TREES TO REMAIN
- EXISTING CATCHBASIN
- EXISTING CATCHBASIN MANHOLE
- EXISTING STORM MANHOLE

PROPOSED LEGEND:

- NEW BARRIER CURB
- NEW WATERMAIN
- NEW STORM SEWER
- NEW HDPE SUBDRAIN
- NEW SANITARY SEWER
- NEW TOP OF SLOPE
- NEW BOTTOM OF SLOPE
- NEW 100mm LINE PAINTING
- HIGH POINT/LOW POINT
- DRAINAGE SWALE & DIRECTION
- UNDERGROUND CONDUIT
- NEW FENCE
- PROPOSED 100YR POND LIMIT
- NEW STORM MANHOLE
- NEW CATCH BASIN/DITCH INLET
- NEW SANITARY MANHOLE
- NEW LANDSCAPE CATCH BASIN
- NEW WATERMAIN VALVE
- NEW TWSI
- NEW BUILDING ENTRANCE
- NEW SIGN
- NEW BOLLARD LIGHT
- NEW LIGHT STANDARD
- NEW PAVEMENT ELEVATION
- NEW LANDSCAPED ELEVATION
- NEW BUILDING ELEVATION
- NEW SWALE ELEVATION
- EXISTING ELEVATION
- NEW HEAVY DUTY ASPHALT
- NEW LIGHT DUTY ASPHALT
- NEW PARTIAL DEPTH ASPHALT
- NEW CONCRETE SIDEWALK
- NEW RIVER STONE
- NEW PAVERS
- NEW BUILDING
- NEW TREES
- OVER FLOW DIRECTION

REMOVALS LEGEND:

- BUILDING EXCAVATION LIMITS
- CURB REMOVAL
- STORM REMOVAL
- UG REMOVAL
- TREE PROTECTION
- FULL DEPTH ASPHALT REMOVAL
- MILLING
- CONCRETE REMOVAL
- ASPHALT SIDEWALK REMOVAL
- TYPICAL REMOVAL

ESC LEGEND:

- LIGHT DUTY SILT FENCE (OPSD 219.110)
- FILTER CLOTH PROTECTION
- MUD MAT
- STRAW BALE CHECK DAM



5	24/07/08	ISSUED FOR FINAL SITE PLAN CONTROL
4	24/04/20	RESUBMISSION FOR SPC PH 3 PRE-CONSULTATION
3	24/04/15	RESUBMISSION FOR SPC PH 3 PRE-CONSULTATION
2	24/01/23	ISSUED FOR SITE PLAN CONTROL REVIEW
1	23/08/20	ISSUED FOR COSTING
0	22/10/07	ISSUED FOR CONCEPT DESIGN

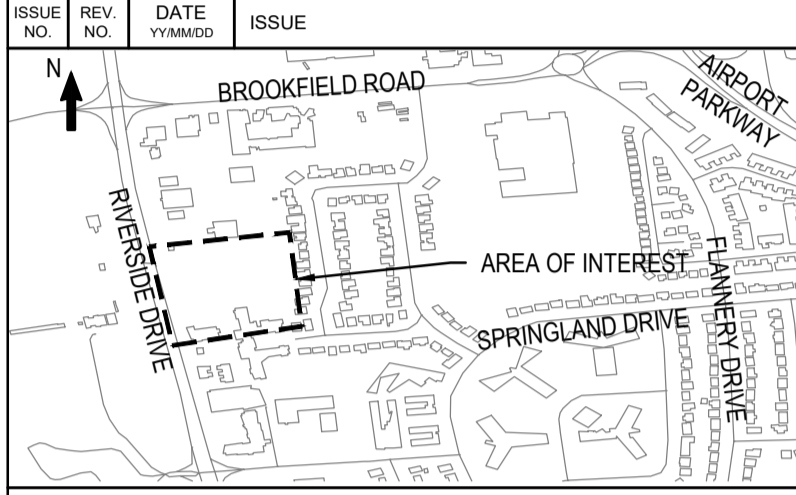

BEARING NOTE
BEARING ARE GRID, DERIVED FROM THE CAN NET VRS NETWORK OBSERVATIONS ON NCD HORIZONTAL CONTROL MONUMENTS 1917025 AND 1980901. CENTRAL MERIDIAN: 79° 00' WEST. CONVERSION WITH ZONE 8. NAD83 (ORIGINAL).
SITE BENCHMARK 1 N 5025565 730 E 38847 808 ELEVATION=85.24
SITE BENCHMARK 2 N 5025567 857 E 38824 568 ELEVATION=85.94

WSP CANADA INC.
2611 QUEENSVIEW DRIVE, SUITE 300
OTTAWA, ONTARIO
CANADA K2B 8K2
PHONE: 613-829-2800
WWW.WSP.COM

DISCLAIMER: THIS DRAWING AND DESIGN IS COPYRIGHT PROTECTED WHICH SHALL NOT BE USED, REPRODUCED OR REVISED WITHOUT WRITTEN PERMISSION BY WSP. THE CONTRACTOR SHALL CHECK AND VERIFY ALL DIMENSIONS AND UTILITY LOCATIONS AND REPORT ALL ERRORS AND OMISSIONS PRIOR TO COMMENCING WORK.

LICENCED PROFESSIONAL ENGINEER
D. B. YANG
100230568
2024-07-08
PROVINCE OF ONTARIO

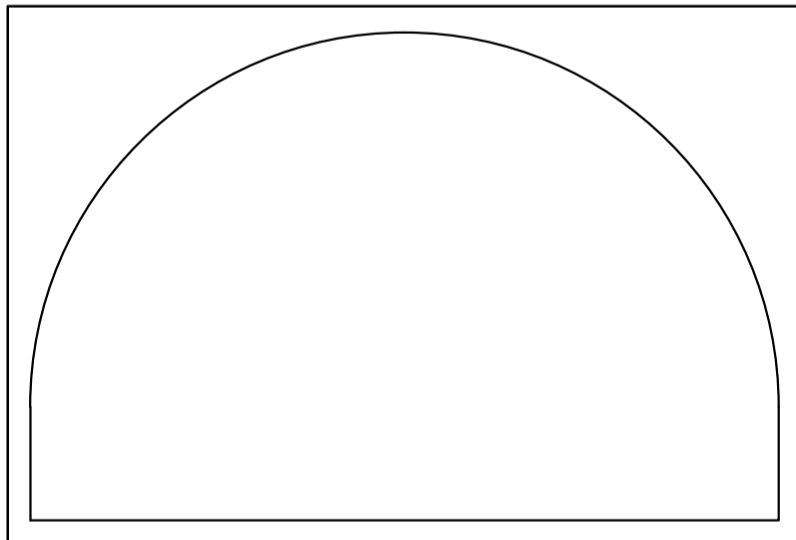

EDWARD J. CUHACI & ASSOCIATES ARCHITECTS Inc.
171 Slaters St, Suite 100, Ottawa, Ontario, K1P 5H7
Fax: (613) 236-1944 Telephone: (613) 236-7135 E-mail: info@cuhaci.com

PROJECT/TITRE DU PROJET
**ST. PATRICK'S HOME
NEW SENIOR APARTMENT BUILDING**

2865 RIVERSIDE DR #226
OTTAWA, ONTARIO K1V 8N5

DRAWING/TITRE DU DESSIN

NOTES AND DETAILS

SCALE ECHELLE	AS SHOWN	PROJ. No 221-08396-00	ISSUE No 5	REV. No 0
DRAWN BY DESSINE PAR	JT	DRAWING/DESSIN		
CHECKED BY VERIFIE PAR	DY	CO		
DATE	JULY 2024			
ACAD FILE/FICHER:				

STORM STRUCTURE	TOP OF GRATE ELEVATION	STRUCTURE INFO						OUTLET	
		INLET	INLET	OUTLET	SIZE	OPSD	COVER	DIAMETER	TYPE
CB201	79.90			78.300	600X600mm	OPSD 705.010	S19.1	250	PVC SDR-35
CB202	80.10			78.500	600X600mm	OPSD 705.010	S19.1	250	PVC SDR-35
CB203	80.93	79.700	79.590	78.980	600X600mm	OPSD 705.010	S19.1	250	PVC SDR-35
STMH201	80.38		77.390	77.390	1200mm DIA.	OPSD 701.010	S24.1	375	PVC SDR-35
STMH202	80.35	78.100	77.370	77.340	1200mm DIA.	OPSD 701.010	S24.1	375	PVC SDR-35
STMH203	80.89		78.646	78.460	1200mm DIA.	OPSD 701.010	S24.1	250	PVC SDR-35
LCB01	80.95			79.950	300mm DIA.	S31	S30	250	HDPE
LCB02	80.95			79.950	300mm DIA.	S31	S30	250	HDPE
LCB03	80.95		79.770	79.770	300mm DIA.	S31	S30	250	HDPE
DICB204	79.09			78.200	300mm DIA.	OPSD 705.010	OPSD 705.030	200	PVC SDR-35

STRUCTURE ID	TOP OF GRATE ELEVATION	INVERT				DESCRIPTION		
		INLET	INLET	INLET	OUTLET	SIZE	OPSD	COVER
SANMH310	80.55			78.783	78.753	1200mm DIA.	OPSD-701.010	S24

ID	Description	Obvert		Invert		Clearance	Obvert	Invert	Notes
		Obvert	Invert	Obvert	Invert				
1	250mmØ PVC SAN	78.910	78.660	0.500	Clearance Above	78.160	77.810	EX.350mmØ PVC W/M	
2	250mmØ PVCSTM	79.882	79.632	1.242	Clearance Above	78.390	78.240	150mmØ PVC W/M	
3	250mmØ PVC STM	78.144	77.894	0.634	Clearance Under	79.078	78.778	EX.300mmØ PVC W/M	
4	250mmØ PVC STM	78.120	77.870	0.210	Clearance Under	78.480	78.330	200mmØ PVC W/M	

*Note: Provide Concrete Encased for corssing clearance less than 0.30m

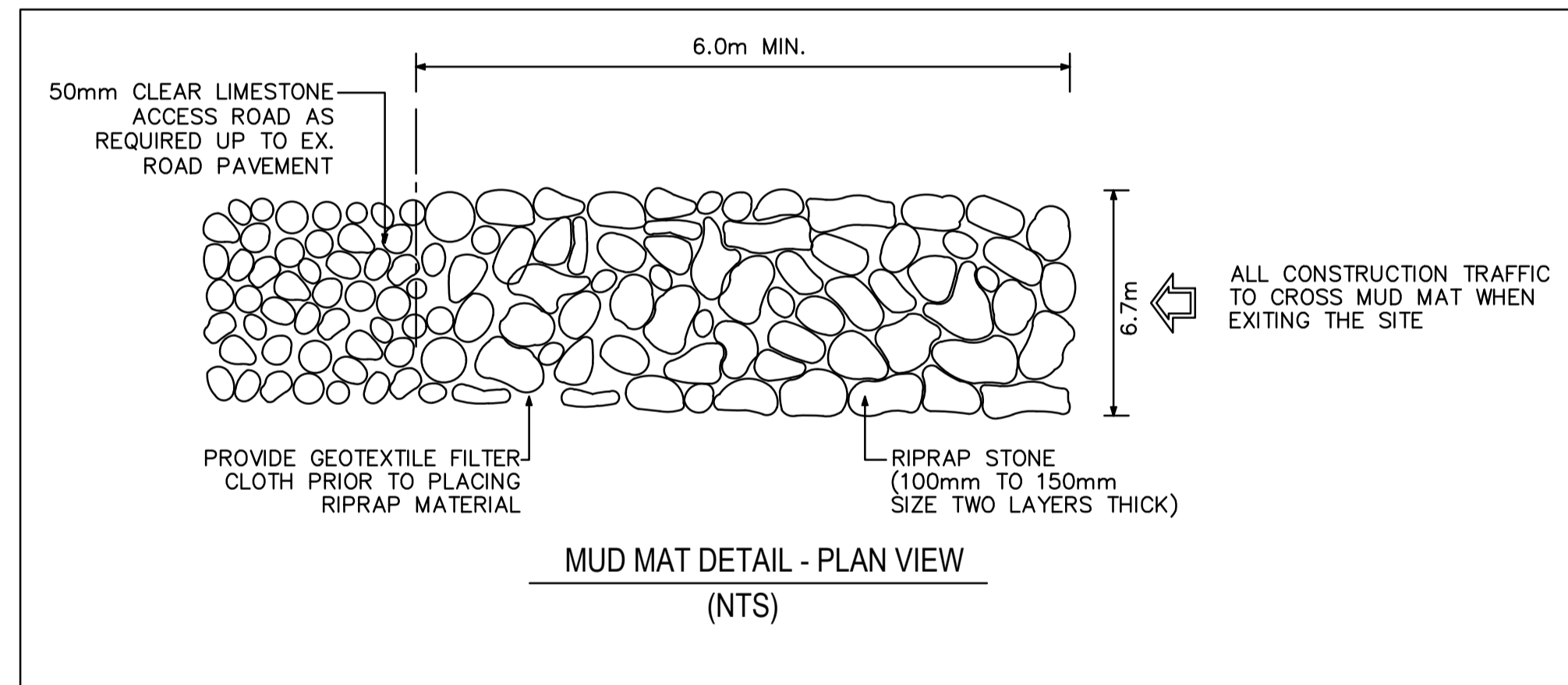
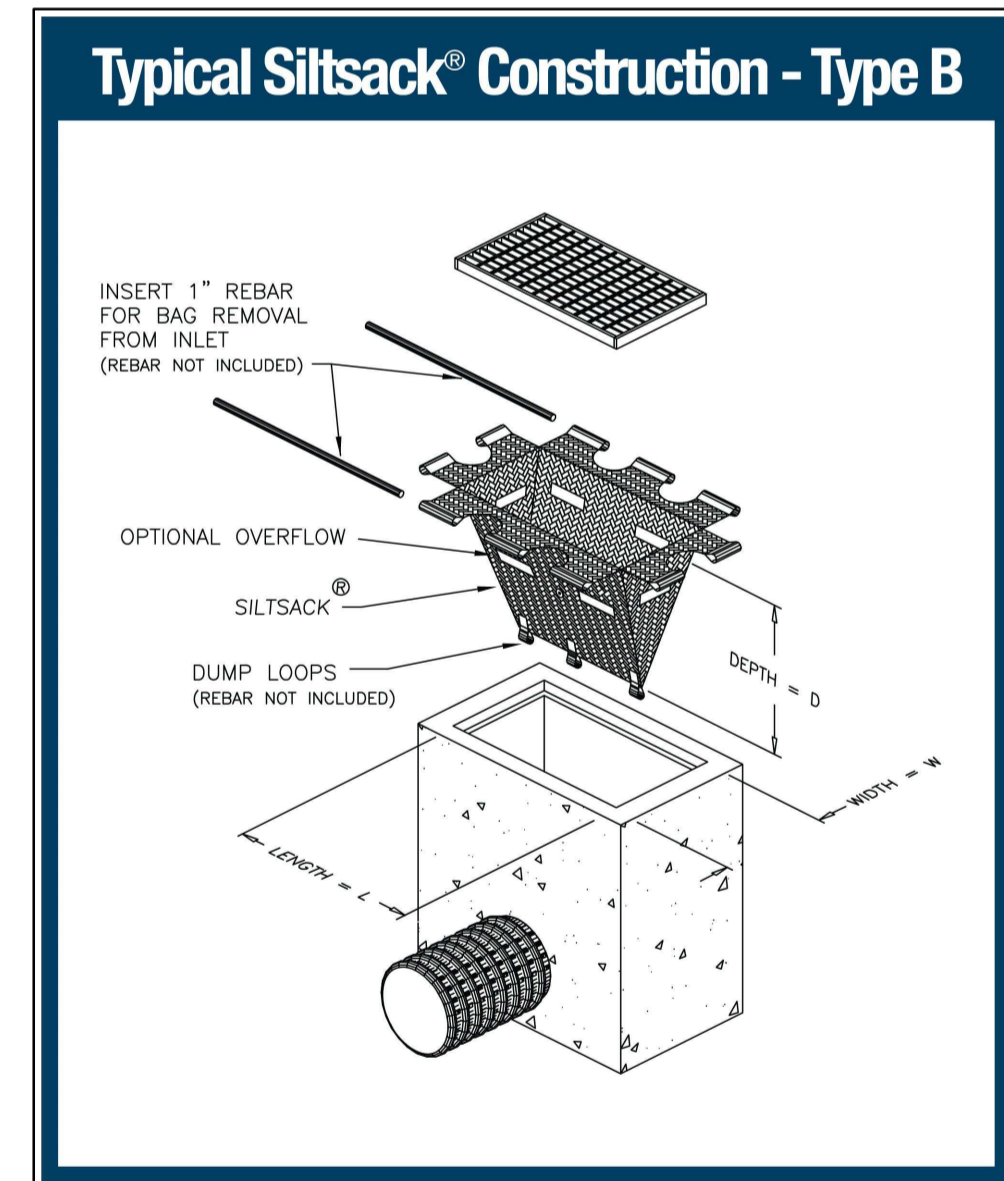

WATERMAIN SCHEDULE				
STATION	DESCRIPTION	FINISHED GRADE	TOP OF WATERMAIN	COVER
150mm WATERMAIN SERVICE FROM BUILDING TO RIVERSIDE DRIVE				
1+000	PROPOSED 150mm CAP	81.25	78.850	2.40
1+002.40	150mm VB	81.04	78.640	2.40
1+011.35	150x150x150 mm Tee	81.04	78.640	2.40
1+033.54	11.25° Bend	81.40	79.000	2.40
1+054.35	150mm VB	80.88	78.480	2.40
1+061.85	Connect to Ex. 305mm W/M WITH 150x300mm Tee	80.64	78.240	2.40

150mm WATERMAIN EXTENSION FROM EXISTING PRIVATE MAIN				
2+011.35	150x150 mm Tee	81.04	78.640	2.40
2+012.80	150mm VB	81.04	78.640	2.40
2+025.37	11.25° Bend	81.06	78.660	2.40
2+032.09	Crossing with 250mm PVC STM	80.98	78.580	2.40
2+042.20	11.25° Bend	80.94	78.540	2.40
2+055.33	150mm VB	81.05	78.650	2.40
2+056.70	CONNECT TO Ex. 150mm W/M WITH 150x150mm Tee	81.13	78.730	2.40

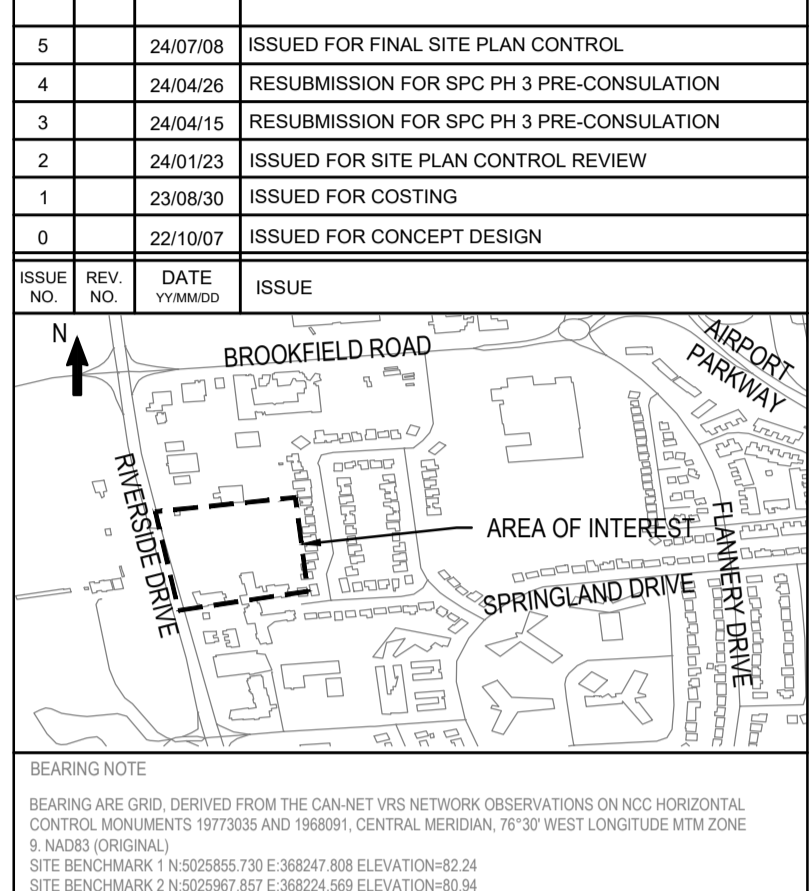

WSP CANADA INC.
2611 QUEENSVIEW DRIVE, SUITE 300
OTTAWA, ONTARIO
CANADA K2B 8K2
PHONE: 613-829-2800
WWW.WSP.COM

DISCLAIMER: THIS DRAWING AND DESIGN IS COPYRIGHT PROTECTED WHICH SHALL NOT BE USED, REPRODUCED OR REVISED WITHOUT WRITTEN PERMISSION BY WSP. THE CONTRACTOR SHALL CHECK AND VERIFY ALL DIMENSIONS AND UTILITY LOCATIONS AND REPORT ALL ERRORS AND OMISSIONS PRIOR TO COMMENCING WORK.

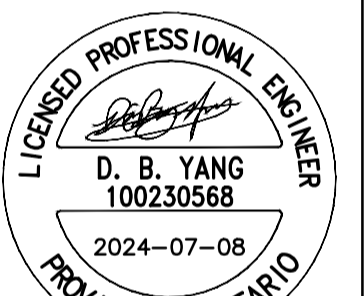
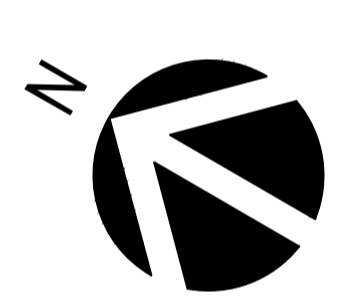

EDWARD J. CUHACI & ASSOCIATES ARCHITECTS Inc.
171 Slaters St, Suite 100, Ottawa, Ontario, K1P 5H7
Fax: (613) 236-1944 Telephone: (613) 236-7135 E-mail: info@cuhaci.com

PROJECT TITLE/TITRE DU PROJET
**ST. PATRICK'S HOME
NEW SENIOR APARTMENT BUILDING**
2865 RIVERSIDE DR.#226
OTTAWA, ONTARIO K1V 8N5

DRAWING TITLE/TITRE DU DESSIN
DETAILS

SCALE ECHELLE	AS SHOWN	PROJ. No 221-08396-00	ISSUE No 5	REV. No 0
DRAWN BY DESSINE PAR	JT	DRAWING/DESSIN		
CHECKED BY VERIFIE PAR	DY	C1		
DATE	JULY 2024			

D07-12-XX-XXXX
#XXXXX



5	24/07/08	ISSUED FOR FINAL SITE PLAN CONTROL
4	24/04/26	RESUBMISSION FOR SPC PH 3 PRE-CONSULTATION
3	24/04/15	RESUBMISSION FOR SPC PH 3 PRE-CONSULTATION
2	24/01/23	ISSUED FOR SITE PLAN CONTROL REVIEW
1	23/08/30	ISSUED FOR COSTING
0	22/10/07	ISSUED FOR CONCEPT DESIGN

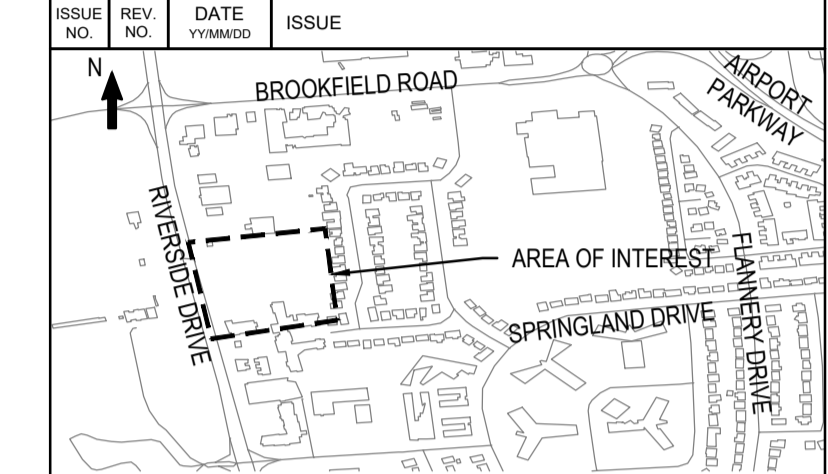

BEARING NOTE
 BEARING AND GRID DERIVED FROM THE CANMET IRS NETWORK OBSERVATIONS ON NAD83 HORIZONTAL CONTROL POINTS 197355 AND 198091, CENTRAL MERIDIAN, 78°30' WEST LONGITUDE NTM ZONE 8 NAD83 (ORIGINAL).
 SITE BENCHMARK 1 N 520585 730 E 38047 808 ELEVATION=82.24
 SITE BENCHMARK 2 N 520587 807 E 38024 589 ELEVATION=81.94



WSP CANADA INC.
 2611 QUEENSWAY DRIVE, SUITE 300
 OTTAWA, ONTARIO
 CANADA K2B 8K2
 PHONE: 613-829-2800
 WWW.WSP.COM

DISCLAIMER: THIS DRAWING AND DESIGN IS COPYRIGHT PROTECTED WHICH SHALL NOT BE USED, REPRODUCED OR REVISED WITHOUT WRITTEN PERMISSION BY WSP. THE CONTRACTOR SHALL CHECK AND VERIFY ALL DIMENSIONS AND UTILITY LOCATIONS AND REPORT ALL ERRORS AND OMISSIONS PRIOR TO COMMENCING WORK.

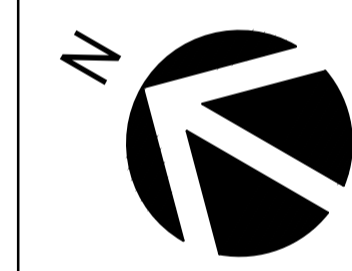

EDWARD J. CUHACI & ASSOCIATES ARCHITECTS Inc.
 171 Slater St, Suite 100, Ottawa, Ontario, K1P 5H7
 Fax: (613) 236-1944 Telephone: (613) 236-7135 E-mail: info@cuhaci.com

PROJECT TITLE/TITRE DU PROJET
**ST. PATRICK'S HOME
 NEW SENIOR APARTMENT BUILDING**
 2865 RIVERSIDE DR #226
 OTTAWA, ONTARIO K1V 8N5

DRAWING TITLE/TITRE DU DESSIN

REMOVAL PLAN

SCALE ECHELLE	1:300	PROJ. No	221-08396-00	ISSUE No	5	REV. No	0
DRAWN BY DESSINE PAR	JT	DRAWING/DESSIN	C2				
CHECKED BY VERIFIE PAR	DY						
DATE	JULY 2024	ACAD FILE/FICHER:					

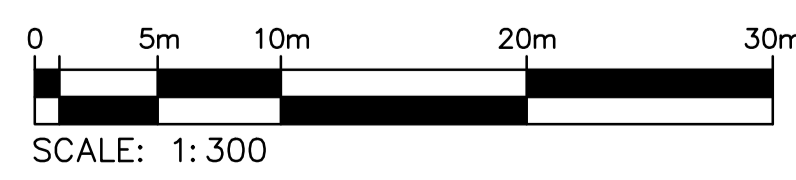
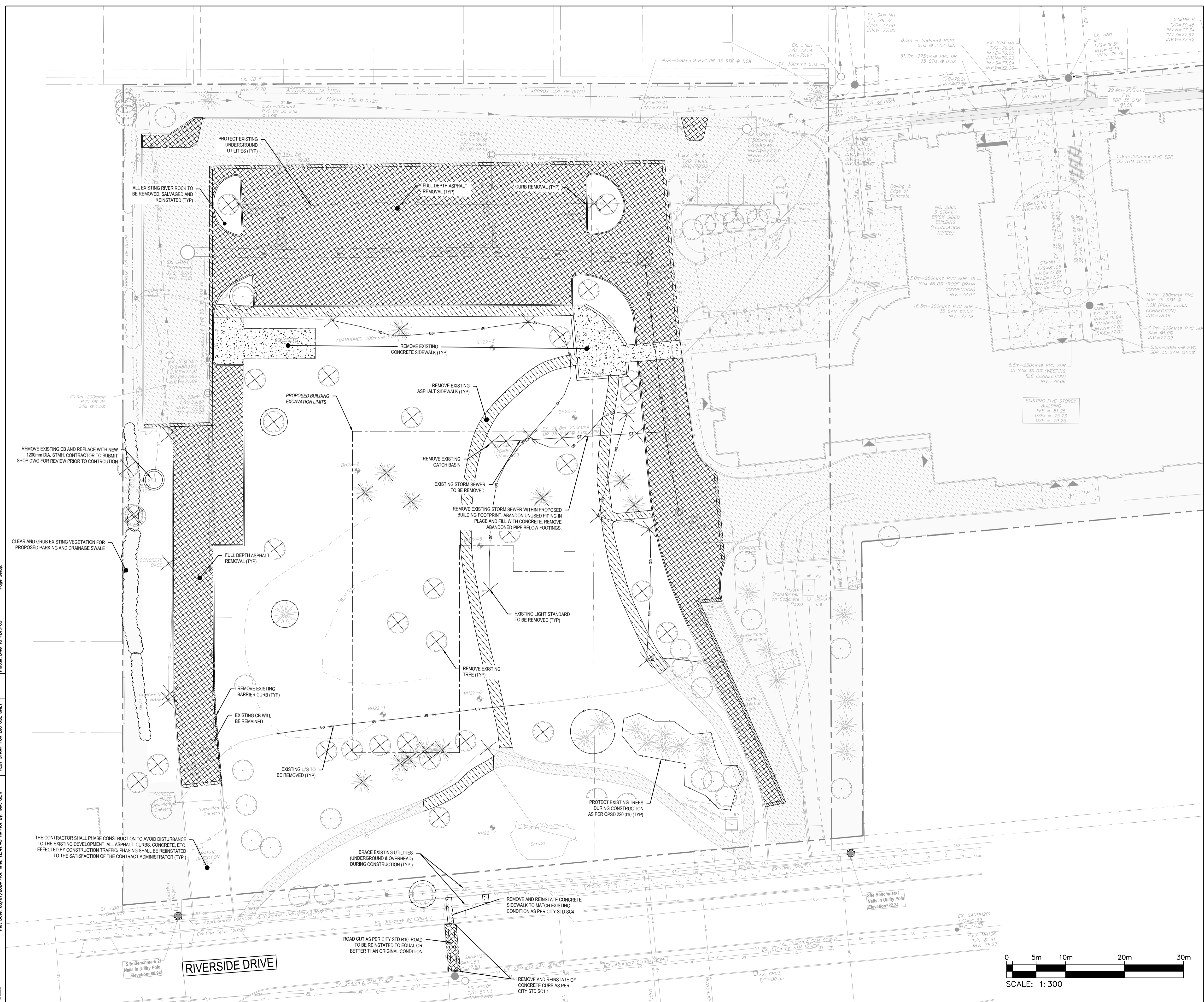

Plot Date: 06/07/2024 Plot Time: 12:41:43 Plot By: JVA, JET
 Plot Stamp For Use Only
 Plotter: DWG TO PDF PLOT32
 Page Status:

#XXXXX



5	24/07/08	ISSUED FOR FINAL SITE PLAN CONTROL
4	24/04/20	RESUBMISSION FOR SPC PH 3 PRE-CONSULTATION
3	24/04/15	RESUBMISSION FOR SPC PH 3 PRE-CONSULTATION
2	24/01/23	ISSUED FOR SITE PLAN CONTROL REVIEW
1	23/08/20	ISSUED FOR COSTING
0	22/10/07	ISSUED FOR CONCEPT DESIGN

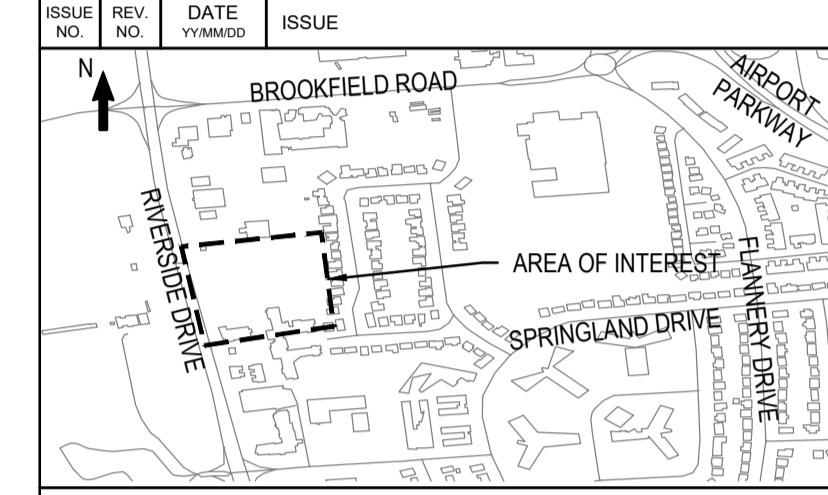

BEARING NOTE
 BEARING ARE GRID, DERIVED FROM THE CAN NET URS NETWORK OBSERVATIONS ON NCD HORIZONTAL CONTROL MONUMENTS 19170265 AND 198901. CENTRAL MERIDIAN, 79° 30' WEST LONGITUDE MTM ZONE 8 NAD83 (ORIGINAL).
 SITE BENCHMARK 1 N 020585 730 E 388247 808 ELEVATION=81.24
 SITE BENCHMARK 2 N 020587 857 E 38824 589 ELEVATION=80.94



WSP CANADA INC.
 2611 QUEENSWAY DRIVE, SUITE 300
 OTTAWA, ONTARIO
 CANADA K2B 8K2
 PHONE: 613-829-2800
 WWW.WSP.COM

DISCLAIMER: THIS DRAWING AND DESIGN IS COPYRIGHT PROTECTED WHICH SHALL NOT BE USED, REPRODUCED OR REVISED WITHOUT WRITTEN PERMISSION BY WSP. THE CONTRACTOR SHALL CHECK AND VERIFY ALL DIMENSIONS AND UTILITY LOCATIONS AND REPORT ALL ERRORS AND OMISSIONS PRIOR TO COMMENCING WORK.

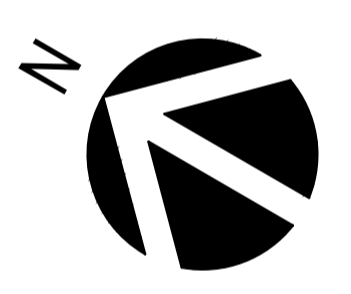

EDWARD J. CUHACI & ASSOCIATES ARCHITECTS Inc.
 171 Slater St, Suite 100, Ottawa, Ontario, K1P 5H7
 Fax: (613) 236-1944 Telephone: (613) 236-7135 E-mail: info@cuhaci.com

PROJECT TITLE/TITRE DU PROJET
**ST. PATRICK'S HOME
 NEW SENIOR APARTMENT BUILDING**
 2865 RIVERSIDE DR #226
 OTTAWA, ONTARIO K1V 8N5

DRAWING TITLE/TITRE DU DESSIN
**SEDIMENT AND EROSION
 CONTROL PLAN**

SCALE ECHELLE	1:300	PROJ. No 221-08396-00	ISSUE No 5	REV. No 0
DRAWN BY DESSINE PAR	JT	DRAWING/DESSIN		
CHECKED BY VERIFIE PAR	DY	C3		
DATE	JULY 2024			
ACAD FILE/FICHIER:				

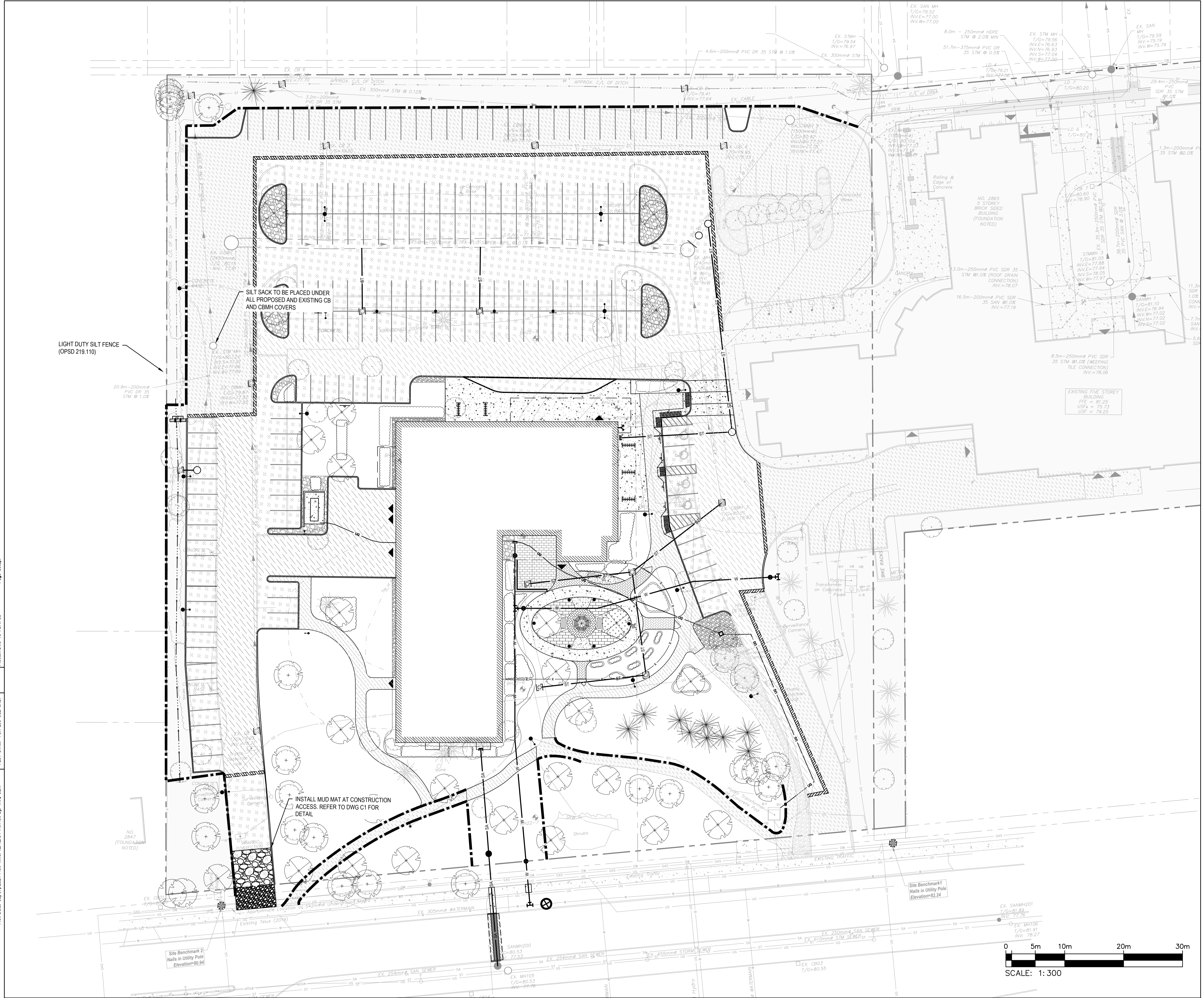

Plot Date: 08/07/2024 Plot Time: 12:42:34 PM Plot By: TAN, JBT
 PLOT STAMP FOR E.A. USE ONLY
 PLOTTER: DWG TO PDF.PC3
 Page Setup:

#XXXXX
 D07-12-XX-XXXX



5	24/07/24	ISSUED FOR FINAL SITE PLAN CONTROL
4	24/04/24	RESUBMISSION FOR SPC PH 3 PRE-CONSULTATION
3	24/04/15	RESUBMISSION FOR SPC PH 3 PRE-CONSULTATION
2	24/01/23	ISSUED FOR SITE PLAN CONTROL REVIEW
1	23/08/20	ISSUED FOR COSTING
0	22/10/07	ISSUED FOR CONCEPT DESIGN

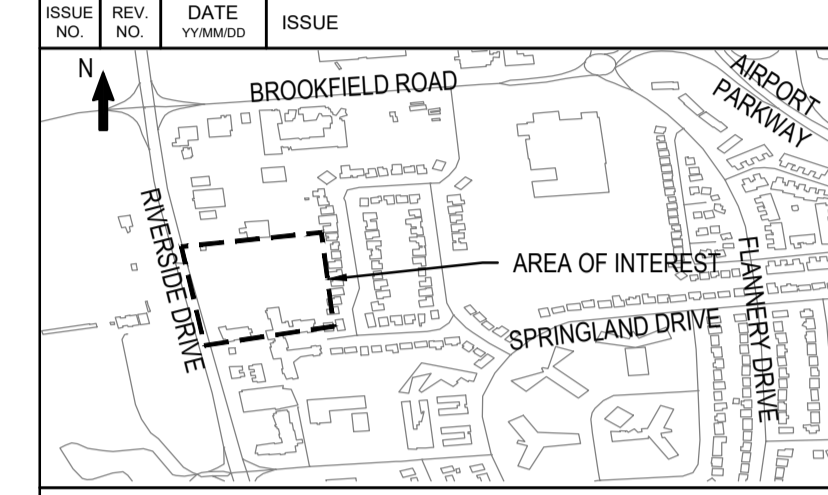

BEARING NOTE
 BEARING ARE GRID, DERIVED FROM THE CAN NET VRS NETWORK OBSERVATIONS ON NCD HORIZONTAL CONTROL MONUMENTS 1970255 AND 198091. CENTRAL MERIDIAN: 79° 00' WEST LONGITUDE: 45° 14' 00" NORTH

WSP

WSP CANADA INC.
 2611 QUEENSWAY DRIVE, SUITE 300
 OTTAWA, ONTARIO
 CANADA K2B 8K2
 PHONE: 613-829-2800
 WWW.WSP.COM

DISCLAIMER: THIS DRAWING AND DESIGN IS COPYRIGHT PROTECTED WHICH SHALL NOT BE USED, REPRODUCED OR VERIFIED WITHOUT WRITTEN PERMISSION BY WSP. THE CONTRACTOR SHALL CHECK AND VERIFY ALL DIMENSIONS AND UTILITY LOCATIONS AND REPORT ALL ERRORS AND OMISSIONS PRIOR TO COMMENCING WORK.

LICENCED PROFESSIONAL ENGINEER

 D. B. YANG
 100230568
 2024-07-08
 PROVINCE OF ONTARIO

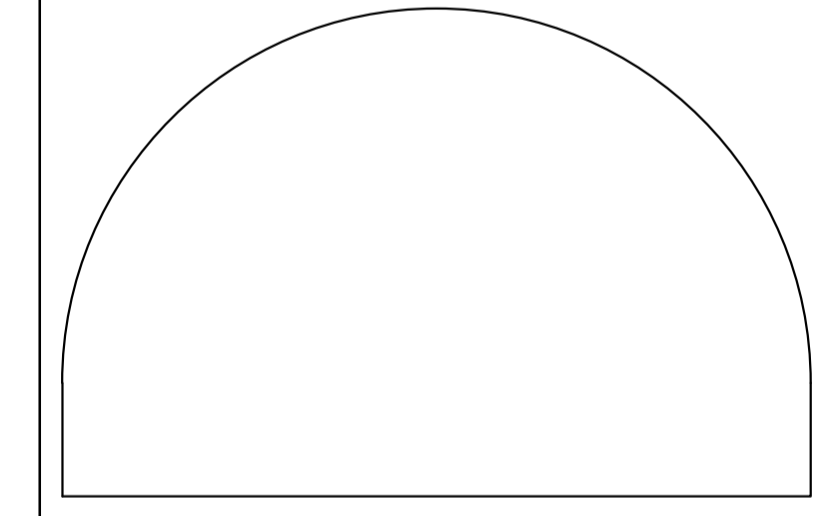

EDWARD J. CUHACI & ASSOCIATES ARCHITECTS Inc.
 171 Slater St, Suite 100, Ottawa, Ontario, K1P 5H7
 Fax: (613) 236-1944 Telephone: (613) 236-7135 E-mail: info@cuhaci.com

PROJECT TITLE/TITRE DU PROJET
**ST. PATRICK'S HOME
 NEW SENIOR APARTMENT BUILDING**
 2865 RIVERSIDE DR #226
 OTTAWA, ONTARIO K1V 8N5

DRAWING TITLE/TITRE DU DESSIN
GRADING PLAN

SCALE ECHELLE	1:300	PROJ. No 221-08396-00	ISSUE No 5	REV. No 0
DRAWN BY DESSINE PAR	JT	DRAWING/DESSIN		
CHECKED BY VERIFIE PAR	DY	C4		
DATE	JULY 2024			

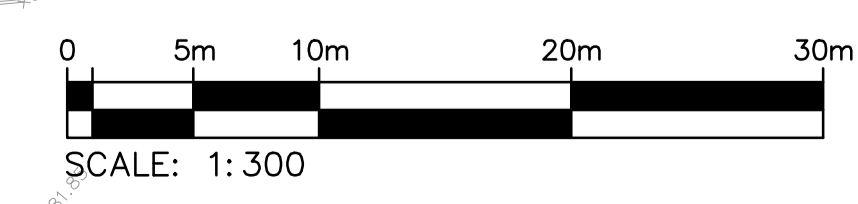
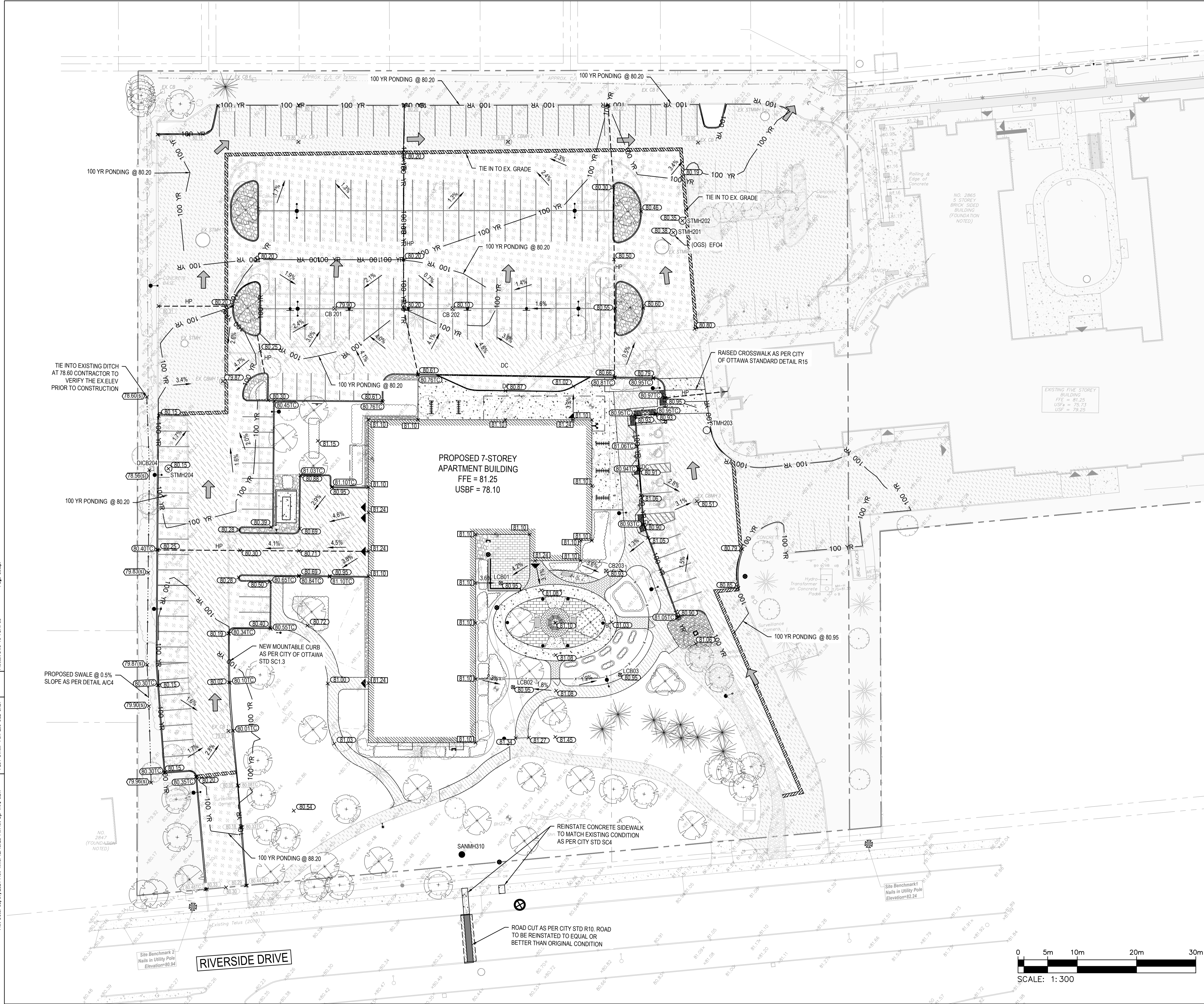

Plot Date: 08/07/2024 Plot Time: 12:42:25 PM Plot By: TAN, JBT
 Plot Stamp For E&P Use Only
 Printer: DWG TO PDF PLOT3

#XXXXX



5	24/07/08	ISSUED FOR FINAL SITE PLAN CONTROL
4	24/04/20	RESUBMISSION FOR SPC PH 3 PRE-CONSULTATION
3	24/04/15	RESUBMISSION FOR SPC PH 3 PRE-CONSULTATION
2	24/01/23	ISSUED FOR SITE PLAN CONTROL REVIEW
1	23/08/20	ISSUED FOR COSTING
0	22/10/07	ISSUED FOR CONCEPT DESIGN

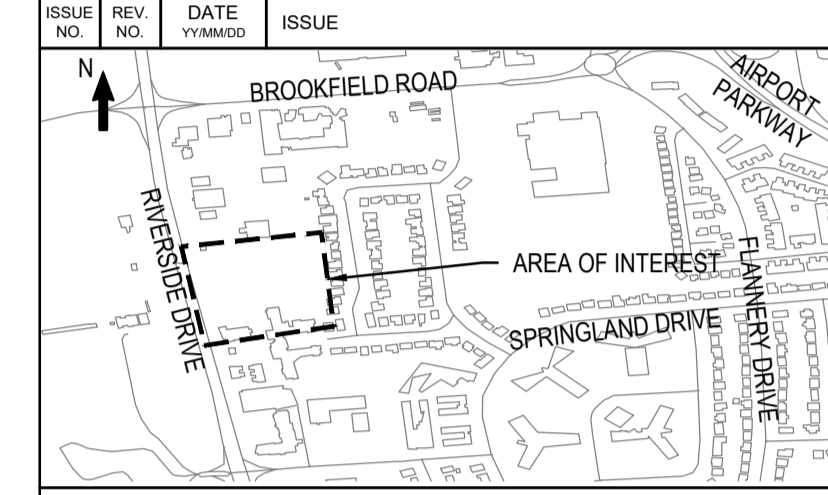

BEARING NOTE
 BEARING ARE GRID, DERIVED FROM THE CAN NET VRS NETWORK OBSERVATIONS ON NCD HORIZONTAL CONTROL MONUMENTS 1970265 AND 1980191. CENTRAL MERIDIAN, 79° 30' WEST LONGITUDE MTN ZONE 8 NAD83 (ORIGINAL).
 SITE BENCHMARK 1 N 0205865 730 E 38847 808 ELEVATION=82.24
 SITE BENCHMARK 2 N 020597 857 E 38824 589 ELEVATION=80.94



WSP CANADA INC.
 2611 QUEENSWAY DRIVE, SUITE 300
 OTTAWA, ONTARIO
 CANADA K2B 8K2
 PHONE: 613-829-2800
 WWW.WSP.COM

DISCLAIMER: THIS DRAWING AND DESIGN IS COPYRIGHT PROTECTED WHICH SHALL NOT BE USED, REPRODUCED OR REVISED WITHOUT WRITTEN PERMISSION BY WSP. THE CONTRACTOR SHALL CHECK AND VERIFY ALL DIMENSIONS AND UTILITY LOCATIONS AND REPORT ALL ERRORS AND OMISSIONS PRIOR TO COMMENCING WORK.

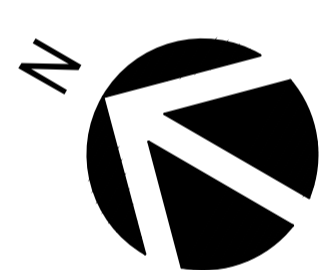

EDWARD J. CUHACI & ASSOCIATES ARCHITECTS Inc.
 171 Slater St, Suite 100, Ottawa, Ontario, K1P 5H7
 Fax: (613) 236-1944 Telephone: (613) 236-7135 E-mail: info@cuhaci.com

PROJECT TITLE/TITRE DU PROJET
**ST. PATRICK'S HOME
 NEW SENIOR APARTMENT BUILDING**
 2865 RIVERSIDE DR.#226
 OTTAWA, ONTARIO K1V 8N5

DRAWING TITLE/TITRE DU DESSIN

SERVICING PLAN

SCALE ECHELLE	1:300	PROJ. No 221-08396-00	ISSUE No 5	REV. No 0
DRAWN BY DESSINE PAR	JT	DRAWING/DESSIN		
CHECKED BY VERIFIE PAR	DY	C5		
DATE	JULY 2024	ACAD FILE/FICHER:		

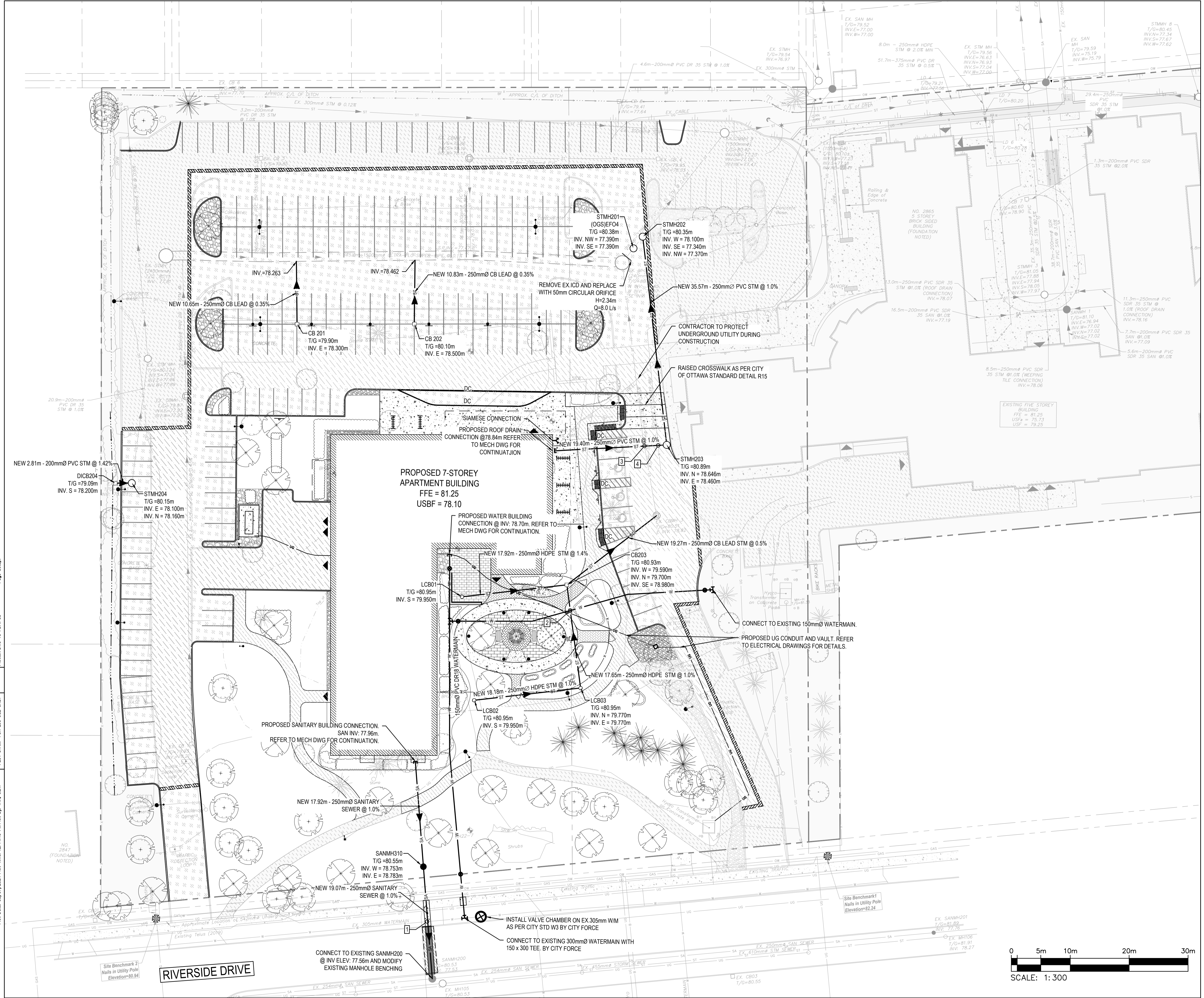

Plot Date: 08/07/2024 Plot Time: 12:41:13 PM Plot By: TAN, JBT
 PLOT Stamp FOR E&P USE ONLY
 PLOTter: DWG TO PDF.PCS
 Page Setup:

#XXXXX

#XXXXX

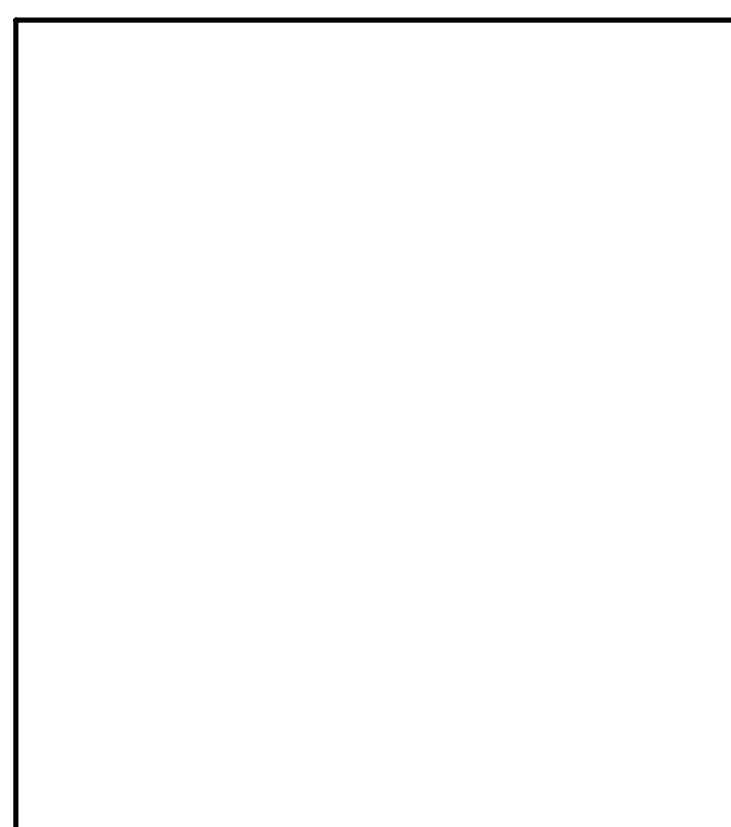
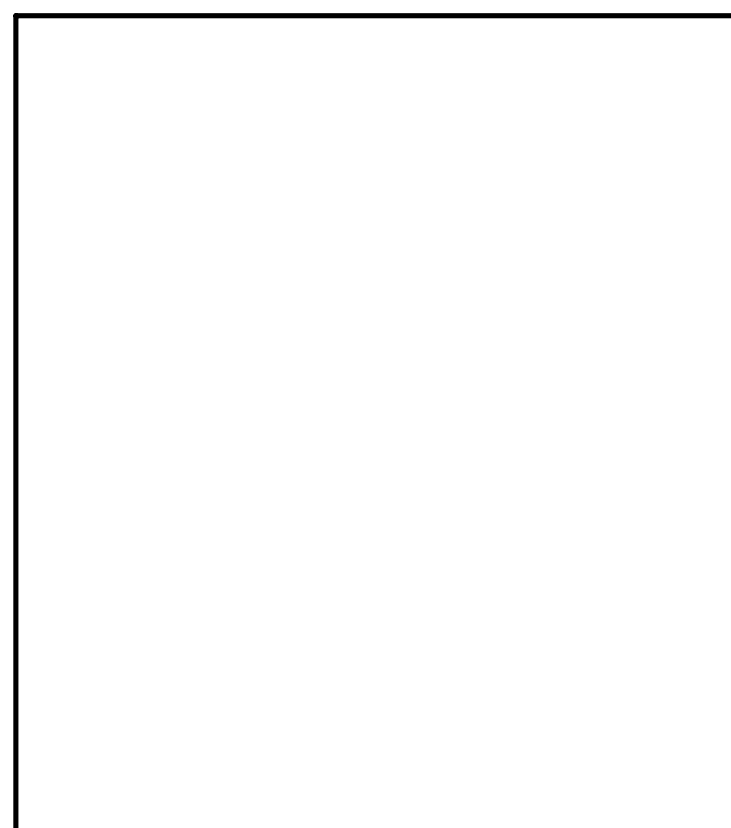
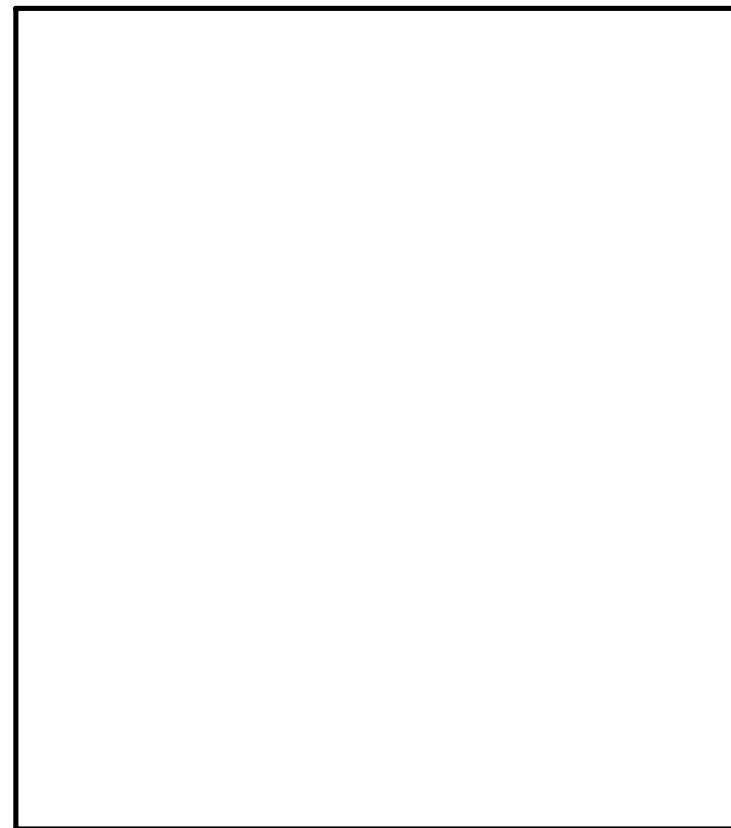
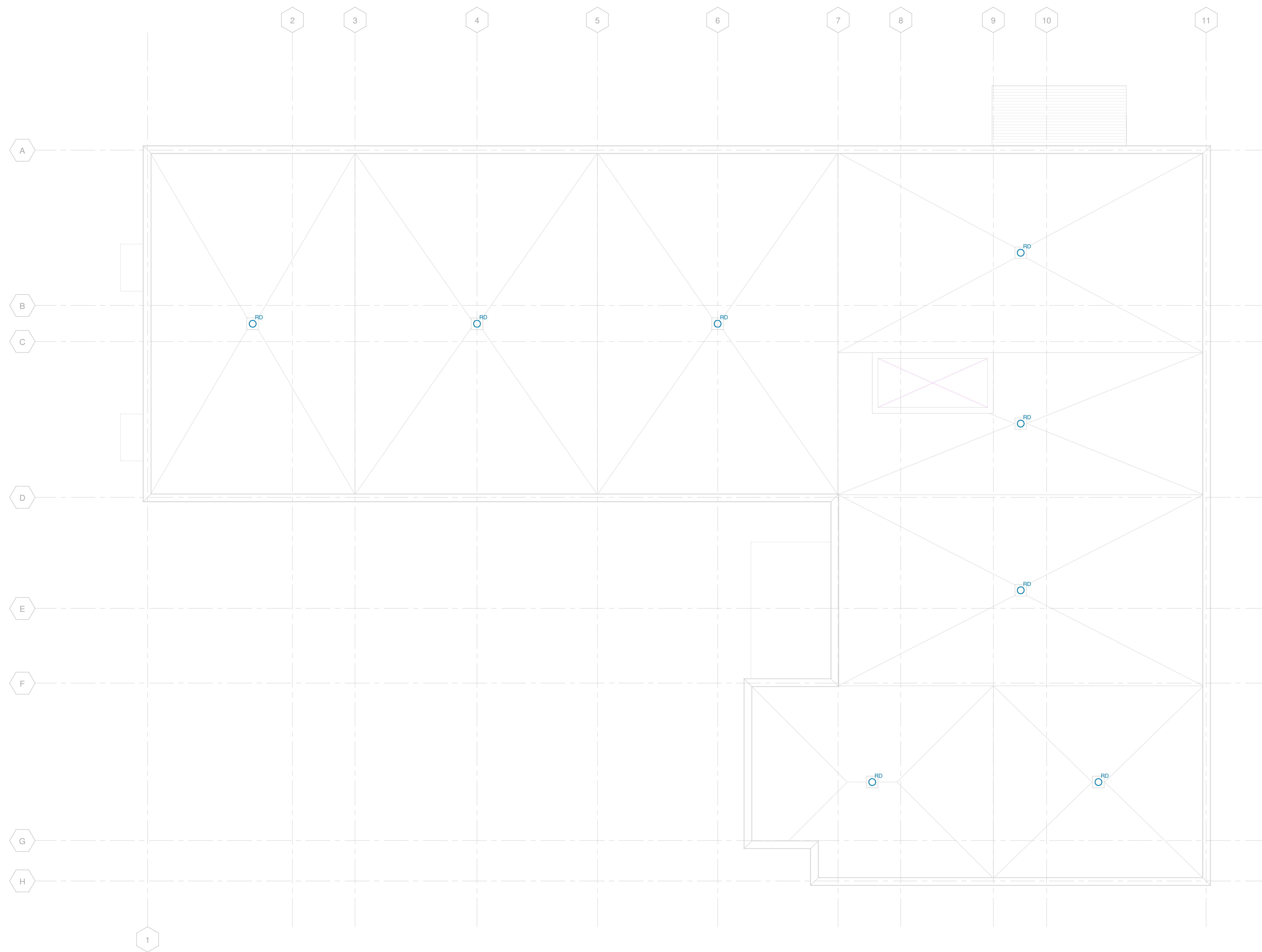

REV	DATE	DESCRIPTION	BY
1	08-09-2023	ISSUED FOR DESIGN DEVELOPMENT	

DISCIPLINE	DATE

DISCLAIMER: THIS DRAWING AND DESIGN ARE COPYRIGHT PROTECTED BY WSP AND SHALL NOT BE USED, REPRODUCED, OR RELEASED WITHOUT WRITTEN PERMISSION FROM WSP. THE CONTRACTOR SHALL CHECK AND VERIFY ALL DIMENSIONS AND FIELD CONDITIONS BEFORE STARTING ALL WORK AND ASSUME RESPONSIBILITY FOR ANY DISCREPANCIES.

DATE: 08-09-2023
IF THIS BAR IS NOT 25mm LONG, PLEASE YOUR PLOTTING SCALE.
25mm

DISCIPLINE

 WSP Canada Inc.

PROJECT NUMBER:
 CLIENT:
 WSP Canada Inc.
 CLIENT REF. #:

PROJECT:
 St. Patrick's Home
 TITLE:
 ROOF - DRAINAGE
 DRAWING NUMBER:
 M-311

REV: R1

APPENDIX

B

General Plan of Services –
Novatech 2011

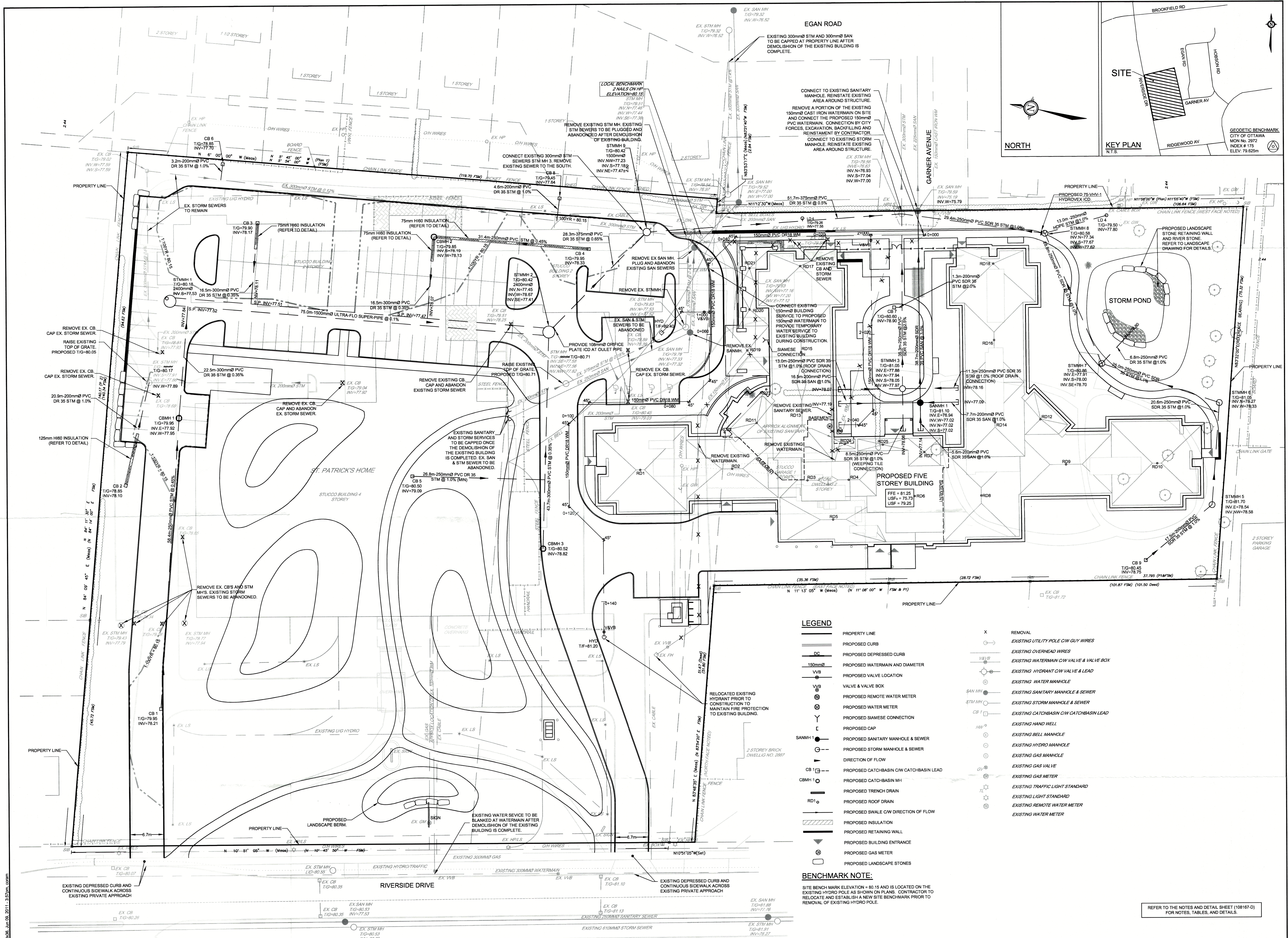

NOTE: THE POSITION OF ALL POLE LINES, CONDUITS, WATERMANS, SEWERS AND OTHER UNDERGROUND AND OVERGROUND UTILITIES AND STRUCTURES IS NOT NECESSARILY SHOWN ON THE CONTRACT DRAWINGS, AND WHERE SHOWN, THE ACCURACY OF THE POSITION OF SUCH UTILITIES AND STRUCTURES IS NOT GUARANTEED. BEFORE STARTING WORK, DETERMINE THE EXACT LOCATION OF ALL SUCH UTILITIES AND STRUCTURES AND ASSUME ALL LIABILITY FOR DAMAGE TO THEM.

OWNER:
 GREY SISTERS OF THE IMMACULATE CONCEPTION
 GREY SISTERS' ADMINISTRATION CENTRE
 720 MACKAY ST.
 PEMBROKE, ON K8A 8J8
 613-735-4111

No.	REVISION	DATE	BY	No.	REVISION	DATE	BY
8	REVISED PER CITY COMMENTS	MAY 13/11	MS	10	REVISED AS PER CITY COMMENTS	JUN 09/11	MS
7	REVISED PER CITY COMMENTS	MAY 03/11	MS	9	ISSUED FOR PRE-TENDER REVIEW	JUN 07/11	MS
6	ISSUED FOR BUILDING PERMIT	MAR 30/11	MS	8	ISSUED FOR REVIEW	AUG 25/10	MS
5	ISSUED FOR FIRE MARSHAL/MOHLTC	MAR 04/11	MS	7	ISSUED FOR REVIEW	AUG 06/10	RSC
4	ISSUED FOR COSTING	JAN 19/11	MS				
3	ISSUED FOR SITE PLAN APPLICATION	OCT 29/10	MS				
2	ISSUED FOR REVIEW	AUG 25/10	MS				
1	ISSUED FOR REVIEW	AUG 06/10	RSC				

SCALE
 1:300
 0 3 6 9 12

FOR REVIEW ONLY
 CJO
 MS
 JPS
 MS
 RSC

NOVATECH
 ENGINEERING
 CONSULTANTS LTD.
 ENGINEERS & PLANNERS
 Suite 200, 240 Michael Cowpland Drive
 Ottawa, Ontario, Canada
 Telephone: (613) 254-9643
 Fax: (613) 254-5867
 Email: novatech@novatech-eng.com

LOCATION
 2865 RIVERSIDE DR. CITY OF OTTAWA
 ST. PATRICKS HOME OTTAWA INC. REDEVELOPMENT

DRAWING NAME
 GENERAL PLAN OF SERVICES

PROJECT No.
 108167

REV
 REV 10

DRAWING No.
 108167-GP

APPENDIX

C

Pre-Development Drainage Area Plan

6	24/07/26	RE-ISSUED FOR FINAL SITE PLAN CONTROL
5	24/07/08	ISSUED FOR FINAL SITE PLAN CONTROL
4	24/04/26	RESUBMISSION FOR SPC PH 3 PRE-CONSULTATION
3	24/04/15	RESUBMISSION FOR SPC PH 3 PRE-CONSULTATION
2	24/01/23	ISSUED FOR SITE PLAN CONTROL REVIEW
1	23/08/20	ISSUED FOR COSTING
0	22/10/07	ISSUED FOR CONCEPT DESIGN

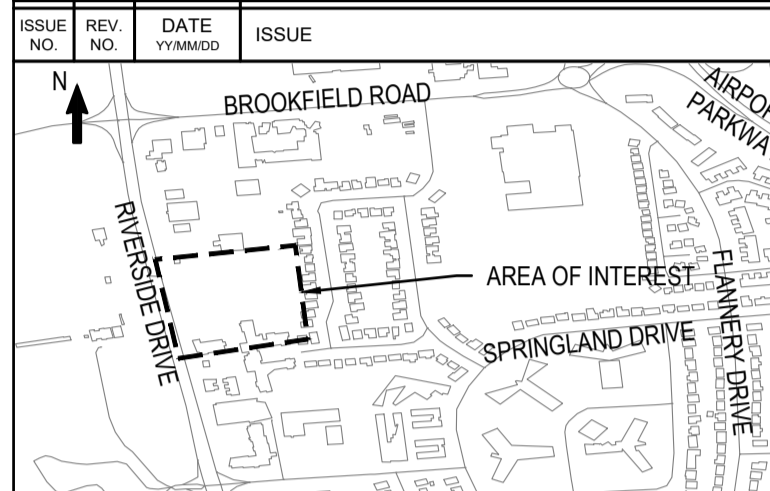

BEARING NOTE
 BEARING ARE GRID, DERIVED FROM THE CAN NET VRS NETWORK OBSERVATIONS ON NCD-HORIZONTAL CONTROL MONUMENTS 197305 AND 198091, CENTRAL MERIDIAN, 79° 30' WEST, LONGITUDE MTM ZONE 8, NAD83 (ORIGINAL).
 SITE BENCHMARK 1 N 020585 730 E 388347 808 ELEVATION=80.24
 SITE BENCHMARK 2 N 020587 857 E 388224 589 ELEVATION=80.94



WSP CANADA INC.
 2611 QUEENSWAY DRIVE, SUITE 300
 OTTAWA, ONTARIO
 CANADA K2B 8K2
 PHONE: 613-829-2800
 WWW.WSP.COM

DISCLAIMER: THIS DRAWING AND DESIGN IS COPYRIGHT PROTECTED WHICH SHALL NOT BE USED, REPRODUCED OR REVISED WITHOUT WRITTEN PERMISSION BY WSP. THE CONTRACTOR SHALL CHECK AND VERIFY ALL DIMENSIONS AND UTILITY LOCATIONS AND REPORT ALL ERRORS AND OMISSIONS PRIOR TO COMMENCING WORK.

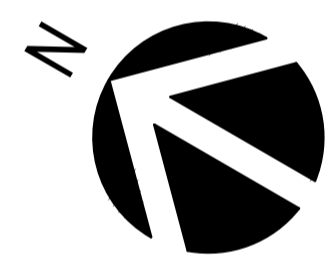

EDWARD J. CUHACI & ASSOCIATES ARCHITECTS Inc.
 171 Slater St., Suite 100, Ottawa, Ontario, K1P 5H7
 Fax: (613) 236-1944 Telephone: (613) 236-7135 E-mail: info@cuhaci.com

PROJECT TITLE/TITRE DU PROJET
**ST. PATRICK'S HOME
 NEW SENIOR APARTMENT BUILDING**
 2865 RIVERSIDE DR.#226
 OTTAWA, ONTARIO K1V 8N5

DRAWING TITLE/TITRE DU DESSIN
**PRE-DEVELOPMENT
 DRAINAGE AREA PLAN**

SCALE ECHELLE	1:400	PROJ. No 221-08396-00	ISSUE No 6	REV. No 0
DRAWN BY DESSINE PAR	JT	DRAWING/DESSIN		
CHECKED BY VERIFIE PAR	DY	C8		
DATE	JULY 2024			



PRE-DEVELOPMENT LEGEND:

- DRAINAGE BOUNDARY LINE
- DRAINAGE AREA SYMBOL
- EXISTING OVER FLOW DIRECTION

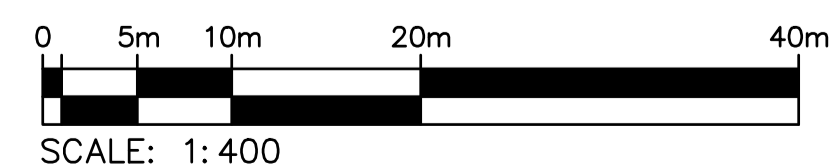

APPENDIX

D

Post-Development Drainage Area
Plan

6	24/07/26	RE-ISSUED FOR FINAL SITE PLAN CONTROL
5	24/07/08	ISSUED FOR FINAL SITE PLAN CONTROL
4	24/04/26	RESUBMISSION FOR SPC PH 3 PRE-CONSULTATION
3	24/04/15	RESUBMISSION FOR SPC PH 3 PRE-CONSULTATION
2	24/01/23	ISSUED FOR SITE PLAN CONTROL REVIEW
1	23/08/30	ISSUED FOR COSTING
0	22/10/07	ISSUED FOR CONCEPT DESIGN

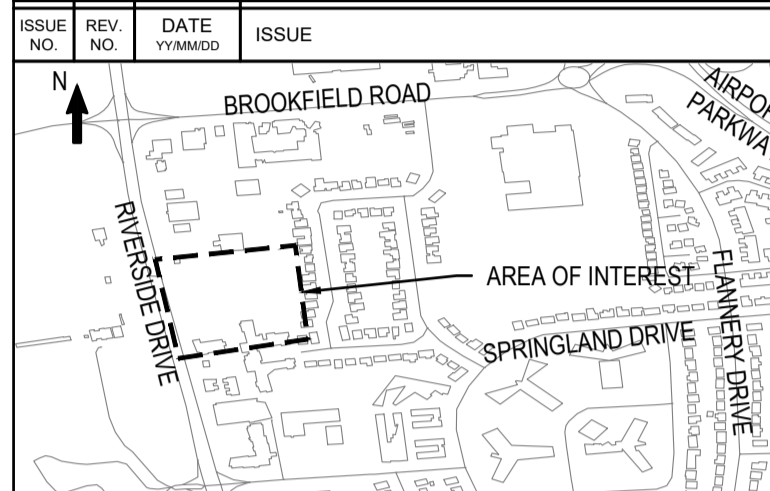

BEARING NOTE
 BEARING ARE GRID, DERIVED FROM THE CAN NET VRS NETWORK OBSERVATIONS ON NCD-HORIZONTAL CONTROL MONUMENTS 1917035 AND 198091. CENTRAL MERIDIAN: 79°30' WEST LONGITUDE WTM ZONE 8 NAD83 (ORIGINAL).
 SITE BENCHMARK 1 N 502585 730 E 388347 808 ELEVATION=80.24
 SITE BENCHMARK 2 N 502587 857 E 38824 589 ELEVATION=80.94



WSP CANADA INC.
 2611 QUEENSVIEW DRIVE, SUITE 300
 OTTAWA, ONTARIO
 CANADA K2B 8K2
 PHONE: 613-829-2800
 WWW.WSP.COM

DISCLAIMER: THIS DRAWING AND DESIGN IS COPYRIGHT PROTECTED WHICH SHALL NOT BE USED, REPRODUCED OR REVISED WITHOUT WRITTEN PERMISSION BY WSP. THE CONTRACTOR SHALL CHECK AND VERIFY ALL DIMENSIONS AND UTILITY LOCATIONS AND REPORT ALL ERRORS AND OMISSIONS PRIOR TO COMMENCING WORK.

EDWARD J. CUHACI & ASSOCIATES ARCHITECTS Inc.
 171 Slater St, Suite 100, Ottawa, Ontario, K1P 5H7
 Fax: (613) 236-1944 Telephone: (613) 236-7135 E-mail: info@cuhaci.com

PROJECT/TITRE DU PROJET
**ST. PATRICK'S HOME
 NEW SENIOR APARTMENT BUILDING**
 2865 RIVERSIDE DR #226
 OTTAWA, ONTARIO K1V 8N5

DRAWING/TITRE DU DESSIN
**POST-DEVELOPMENT
 DRAINAGE AREA PLAN**

SCALE	1:400	PROJ. No	221-08396-00	ISSUE No	6	REV. No	0
ECHELLE		DRAWING/DESSIN					
DRAWN BY	JT						
DESSINE PAR							
CHECKED BY	DY						
VERIFIE PAR							
DATE	JULY 2024						

C9

ACAD FILE/FICHER:

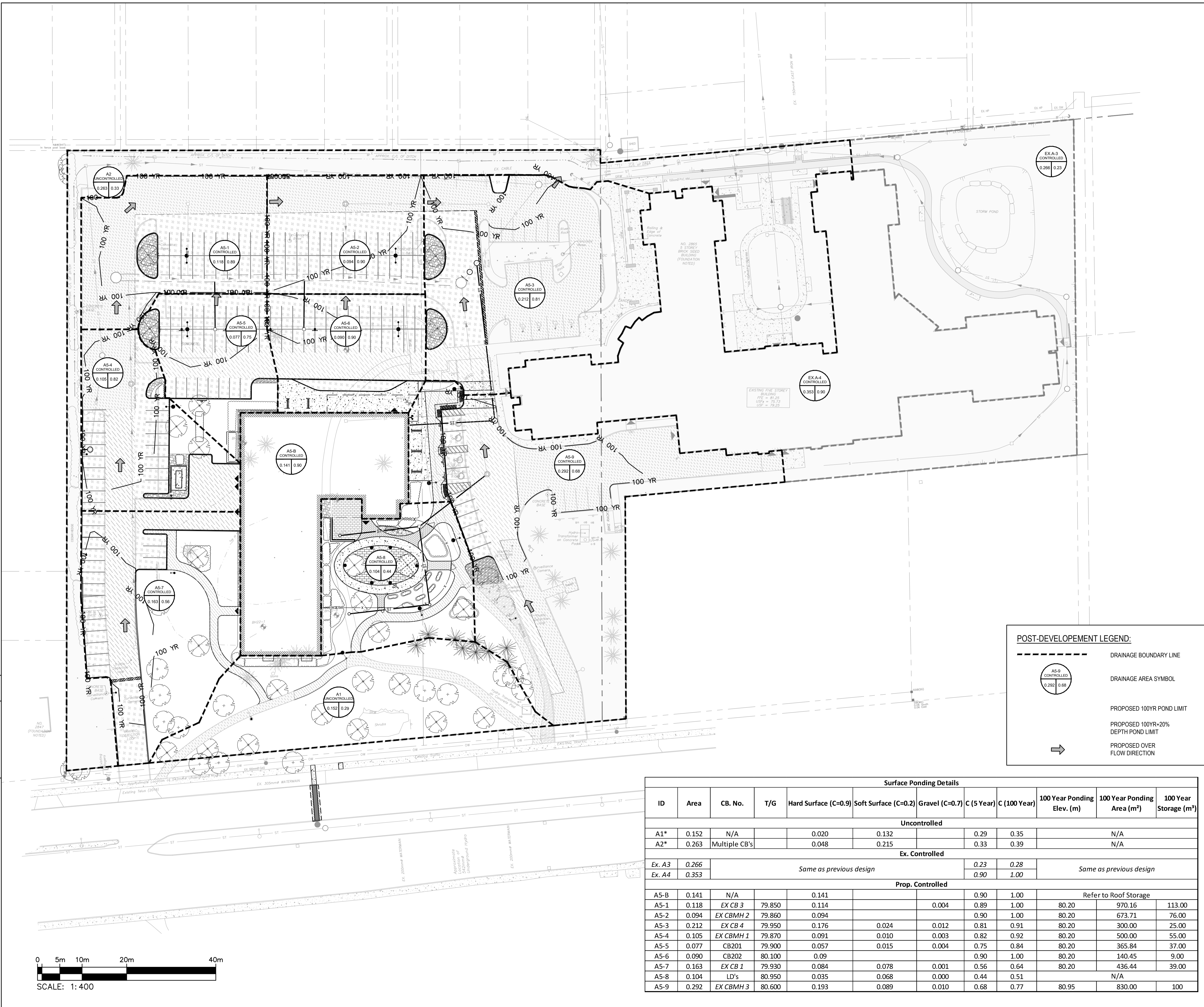

POST-DEVELOPMENT LEGEND:

- DRAINAGE BOUNDARY LINE
- DRAINAGE AREA SYMBOL
- PROPOSED 100YR POND LIMIT
- PROPOSED 100YR-20% DEPTH POND LIMIT
- PROPOSED OVER FLOW DIRECTION

Surface Ponding Details												
ID	Area	CB. No.	T/G	Hard Surface (C=0.9)	Soft Surface (C=0.2)	Gravel (C=0.7)	C (5 Year)	C (100 Year)	100 Year Ponding Elev. (m)	100 Year Ponding Area (m²)	100 Year Storage (m³)	
Uncontrolled												
A1*	0.152	N/A		0.020	0.132		0.29	0.35		N/A		
A2*	0.263	Multiple CB's		0.048	0.215		0.33	0.39		N/A		
Ex. Controlled												
Ex. A3	0.266			Same as previous design				0.23	0.28	Same as previous design		
Ex. A4	0.353							0.90	1.00			
Prop. Controlled												
A5-B	0.141	N/A		0.141			0.90	1.00	Refer to Roof Storage			
A5-1	0.118	EX CB 3	79.850	0.114		0.004	0.89	1.00	80.20	970.16	113.00	
A5-2	0.094	EX CBMH 2	79.860	0.094			0.90	1.00	80.20	673.71	76.00	
A5-3	0.212	EX CB 4	79.950	0.176	0.024	0.012	0.81	0.91	80.20	300.00	25.00	
A5-4	0.105	EX CBMH 1	79.870	0.091	0.010	0.003	0.82	0.92	80.20	500.00	55.00	
A5-5	0.077	CB201	79.900	0.057	0.015	0.004	0.75	0.84	80.20	365.84	37.00	
A5-6	0.090	CB202	80.100	0.09			0.90	1.00	80.20	140.45	9.00	
A5-7	0.163	EX CB 1	79.930	0.084	0.078	0.001	0.56	0.64	80.20	436.44	39.00	
A5-8	0.104	LD's	80.950	0.035	0.068	0.000	0.44	0.51		N/A		
A5-9	0.292	EX CBMH 3	80.600	0.193	0.089	0.010	0.68	0.77	80.95	830.00	100	

Plot Stamp For E.P. Use Only
 Plot Date: 25/07/2024 Plot Time: 5:35:07 PM Plot By: TAN, JET1
 Path: J:\PROJECTS\2024\221-08396-00\GENERAL_DOCUMENTS\221-08396-00-06.dwg

D07-12-24-0064

APPENDIX

E

PCSWMM Model

E-1 PCSWMM Model Schematics

E-2 PCSWMM Model Parameters

Subcatchment Summary

Name	Outlet	Area (ha)	Width (m)	Flow Length (m)	Slope (%)	Imperv. (%)	N Imperv	N Perv	Dstore Imperv (mm)	Dstore Perv (mm)	Zero Imperv (%)	Subarea Routing	Percent Routed (%)	Infiltration Method	Max. Infil. Rate (mm/hr)	Min. Infil. Rate (mm/hr)	Decay Constant (1/hr)	Drying Time (days)	Suction Head (mm)	Conductivity (mm/hr)	Initial Deficit (frac.)	Curve Number
A1	OF2	0.152	55.19	27.541	0.736	13.15	0.013	0.25	1.57	4.67	100	IMPERVIOUS	100	HORTON	76.2	13.2	4.14	7	3.5	0.5	0.25	80
A2_1	SU6	0.0598	35.176	17	0.642	1	0.013	0.25	1.57	4.67	57.511	OUTLET	100	HORTON	76.2	13.2	4.14	7	3.5	0.5	0.25	80
A2_2	SU8	0.0195	19.5	10	0.642	1	0.013	0.25	1.57	4.67	57.511	OUTLET	100	HORTON	76.2	13.2	4.14	7	3.5	0.5	0.25	80
A2_3	EX-STM-MH	0.1292	51.68	25	0.642	36.87	0.013	0.25	1.57	4.67	57.511	OUTLET	100	HORTON	76.2	13.2	4.14	7	3.5	0.5	0.25	80
A2_4	SU7	0.0431	30.786	14	0.642	1	0.013	0.25	1.57	4.67	57.511	OUTLET	100	HORTON	76.2	13.2	4.14	7	3.5	0.5	0.25	80
A2_5	SU1	0.0123	15.375	8	0.642	1	0.013	0.25	1.57	4.67	57.511	OUTLET	100	HORTON	76.2	13.2	4.14	7	3.5	0.5	0.25	80
A-3Ex	OF4	0.266	73.889	36	0.5	25	0.013	0.25	1.57	4.67	25	OUTLET	100	HORTON	76.2	13.2	4.14	7	3.5	0.5	0.25	80
A-4EX	OF3	0.353	84.048	42	0.5	25	0.013	0.25	1.57	4.67	25	OUTLET	100	HORTON	76.2	13.2	4.14	7	3.5	0.5	0.25	80
A5-1	SU2	0.118	48.618	24.271	1	96.6	0.013	0.25	1.57	4.67	100	OUTLET	100	HORTON	76.2	13.2	4.14	7	3.5	0.5	0.25	80
A5-2	SU3	0.094	44.762	21	1	100	0.013	0.25	1.57	4.67	100	OUTLET	100	HORTON	76.2	13.2	4.14	7	3.5	0.5	0.25	80
A5-3	SU13_pr	0.2126	66.438	32	1	83.01	0.013	0.25	1.57	4.67	100	OUTLET	100	HORTON	76.2	13.2	4.14	7	3.5	0.5	0.25	80
A5-4	SU4	0.105	45.652	23	1	86.67	0.013	0.25	1.57	4.67	100	OUTLET	100	HORTON	76.2	13.2	4.14	7	3.5	0.5	0.25	80
A5-5	SU11_pr	0.077	40.526	19	1	75.03	0.013	0.25	1.57	4.67	100	OUTLET	100	HORTON	76.2	13.2	4.14	7	3.5	0.5	0.25	80
A5-6	SU12_pr	0.09	42.857	21	1	100	0.013	0.25	1.57	4.67	100	OUTLET	100	HORTON	76.2	13.2	4.14	7	3.5	0.5	0.25	80
A5-7	SU5	0.163	58.214	28	0.96	51.53	0.013	0.25	1.57	4.67	100	OUTLET	100	HORTON	76.2	13.2	4.14	7	3.5	0.5	0.25	80
A5-8	CB203	0.104	45.217	23	0.962	33.65	0.013	0.25	1.57	4.67	100	OUTLET	100	HORTON	76.2	13.2	4.14	7	3.5	0.5	0.25	80
A5-9	SU10	0.292	76.842	38	0.868	65.095	0.013	0.25	1.57	4.67	80.256	OUTLET	100	HORTON	76.2	13.2	4.14	7	3.5	0.5	0.25	80
A5-B-Roof	Roof-Storage	0.141	54.231	26	1	100	0.013	0.25	1.57	4.67	100	OUTLET	100	HORTON	76.2	13.2	4.14	7	3.5	0.5	0.25	80

Junctions Summary

Name	X-Coordinate	Y-Coordinate	Tag	Inflows	Treatment	Invert Elev. (m)	Rim Elev. (m)	Depth (m)
CB201	368327.366	5025955.393		NO	NO	78.3	79.9	1.6
CB202	368329.545	5025935.56		NO	NO	78.5	80.1	1.6
CB203	368287.994	5025902.769		NO	NO	78.98	80.95	1.97
DI01	368297.215	5025984.514		NO	NO	78.2	79.25	1.05
ExCB	368360.606	5025988.224		NO	NO	77.59	79.03	1.44
Ex-CB1	368254.777	5025965.161		NO	NO	78.21	79.93	1.72
ExCB2	368297.688	5025980.172		NO	NO	78.1	78.83	0.73
Ex-CB3	368354.68	5025964.487		NO	NO	78.17	79.85	1.68
ExCB4	368361.893	5025897.185		NO	NO	78.33	79.95	1.62
ExCB6	368364.259	5025973.124		NO	NO	77.7	78.83	1.13
ExCB8	368371.084	5025905.125		NO	NO	77.64	79.41	1.77
Ex-CBMH1	368313.24	5025972.593		NO	NO	77.92	79.87	1.95
Ex-CBMH2	368358.751	5025929.318		NO	NO	78.13	79.86	1.73
ExCBMH3	368302.01	5025890.95		NO	NO	78.82	80.6	1.78
ExMH103	368343.965	5025901.586		NO	NO	77.41	80.41	3
ExSTMH	368318.845	5025979.777		NO	NO	77.86	80.12	2.26
Ex-STMH1	368336.449	5025978.593		NO	NO	77.81	80.15	2.34
Ex-STMH9	368367.711	5025886.861		NO	NO	77.18	80.42	3.24
EX-STM-MH	368381.367	5025836.827		NO	NO	76.63	79.56	2.93
J1	368338.793	5025956.642		NO	NO	77.503	80.186	2.683
J17	368336.844	5025976.067		NO	NO	77.525	80.15	2.625
J2	368341.25	5025936.764		NO	NO	77.5	80.304	2.804
J20	368338.046	5025962.688		NO	NO	77.51	80.15	2.64
J25	368363.079	5025973.02		NO	NO	77.412	78.84	1.428
J26	368366.893	5025904.875		NO	NO	77.323	79.42	2.097
J6	368342.41	5025927.381		NO	NO	77.47	80.36	2.89
OGS-STMH201	368345.319	5025900.765		NO	NO	77.39	80.45	3.06
STM01	368312.386	5025909.192		NO	NO	78.23	83.23	5
STMMH202	368346.362	5025900.109		NO	NO	77.37	80.37	3
STMMH203	368315.448	5025890.59		NO	NO	77.81	80.93	3.12

Orifice Summary

Name	Inlet Node	Outlet Node	Type	Cross-Section	Height (m)	Width (m)	Inlet Elev. (m)
C13_5	ExMH103	OGS-STMH201	SIDE	CIRCULAR	0.05	0	77.41
C16	Roof-Storage	STM01	SIDE	CIRCULAR	0.2	0	88.23

Conduits Summary

Name	Inlet Node	Outlet Node	Length (m)	Roughness	Inlet Elev. (m)	Outlet Elev. (m)	Entry Loss Coeff.	Exit Loss Coeff.	Cross-Section	Geom1 (m)
C1	ExCB4	Ex-CBMH2	31.4	0.01	78.33	78.19	0	0	CIRCULAR	0.25
C1_2	STMMH203	STMMH202	35.55	0.01	77.81	77.45	0	0	1 CIRCULAR	0.25
C10	J17	J20	13.46	0.013	77.525	77.51	0	0	CIRCULAR	1.5
C11	Ex-CB3	J20	16.5	0.013	78.17	78.11	0.3	0.9	CIRCULAR	0.3
C12	CB202	J2	10.8	0.01	78.5	77.5	0	0	CIRCULAR	0.25
C12_1	J20	J1	6.093	0.01	77.51	77.503	0	0	CIRCULAR	1.5
C12_3	J1	J2	20.03	0.01	77.503	77.5	0	0	CIRCULAR	1.5
C12_4	J2	J6	9.455	0.01	77.5	77.47	0	0	CIRCULAR	1.5
C13	ExCBMH3	ExMH103	43.7	0.01	78.82	78.67	0.3	0.9	CIRCULAR	0.3
C13_2	STMMH202	Ex-STMH9	25.122	0.013	77.4	77.23	0.3	1	CIRCULAR	0.375
C13_6	OGS-STMH201	STMMH202	1.589	0.013	77.39	77.37	0.3	0.7	CIRCULAR	0.375
C14	Ex-STMH9	Ex-STM-MH	51.7	0.013	77.18	76.93	0.3	0.9	CIRCULAR	0.375
C15	Ex-STM-MH	OF1	30.194	0.013	76.63	75	0.3	0.7	CIRCULAR	0.3
C17	DI01	ExCB2	4	0.013	78.2	78.16	0.3	0.9	CIRCULAR	0.2
C18	ExCB2	ExSTMH	20.9	0.013	78.1	77.89	0.3	0.6	CIRCULAR	0.2
C19	ExSTMH	ExCB	42.607	0.013	77.86	77.59	0.3	0.9	CIRCULAR	0.3
C2	STM01	STMMH203	18.4	0.013	78.05	77.87	0.3	0.7	CIRCULAR	0.25
C20	ExCB	J25	15.404	0.013	77.59	77.412	0.3	0.6	CIRCULAR	0.3
C21	J25	J26	68.252	0.013	77.412	77.323	0.3	0	CIRCULAR	0.3
C22	J26	Ex-STMH9	18.032	0.013	77.323	77.47	0	0.9	CIRCULAR	0.3
C23	ExCB6	J25	3.2	0.013	77.7	77.412	0.3	0.9	CIRCULAR	0.2
C24	ExCB8	J26	4.6	0.013	77.64	77.323	0.3	0.9	CIRCULAR	0.2
C3	SU13_pr	ExCB4	1.536	0.01	80.2	78.33	0	0	CIRCULAR	0.25
C4	CB201	J1	10.65	0.01	78.3	77.503	0	0	CIRCULAR	0.25
C4_2	CB203	ExCBMH3	19.4	0.01	78.98	78.88	0.3	0.9	CIRCULAR	0.25
C5	J6	ExMH103	25.88	0.013	77.47	77.45	0	0.9	CIRCULAR	1.5
C6	Ex-CBMH2	J6	16.5	0.013	78.13	78.07	0.3	0.9	CIRCULAR	0.3
C7	Ex-STMH1	J17	2.57	0.013	77.81	77.525	0.3	0	CIRCULAR	1.5
C8	Ex-CB1	Ex-CBMH1	58.4	0.013	78.21	77.95	0.3	0.5	CIRCULAR	0.25
C9	Ex-CBMH1	J17	22.5	0.013	77.92	77.525	0.3	0.9	CIRCULAR	0.3
OR1	SU1	ExCB	2.035	0.01	77.61	77.59	0	0	CIRCULAR	0.25
OR10	SU10	ExCBMH3	1.542	0.01	80.95	78.82	0	0	CIRCULAR	0.25
OR11	SU11_pr	CB201	1.506	0.01	80.2	78.3	0	0	CIRCULAR	0.25
OR12	SU12_pr	CB202	1.485	0.01	80.2	78.5	0	0	CIRCULAR	0.25
OR2	SU2	Ex-CB3	1.716	0.01	80.2	78.17	0	0	CIRCULAR	0.25
OR3	SU3	Ex-CBMH2	1.703	0.01	80.2	78.13	0	0	CIRCULAR	0.25
OR4	SU4	Ex-CBMH1	1.926	0.01	80.2	77.92	0	0	CIRCULAR	0.25
OR5	SU5	Ex-CB1	3.349	0.01	80.2	78.21	0	0	CIRCULAR	0.25
OR6	SU6	DI01	2.934	0.01	78.23	78.2	0	0	CIRCULAR	0.25
OR7	SU7	ExCB8	2.004	0.01	77.66	77.64	0	0	CIRCULAR	0.25
OR8	SU8	ExCB6	1.439	0.01	77.715	77.7	0	0	CIRCULAR	0.25

Storage Summary

Name	Inflows	Treatment	Invert Elev. (m)	Rim Elev. (m)	Depth (m)	Storage Curve	Coefficient	Curve Name
Roof-Stora	NO	NO	88.23	88.38	0.15	TABULAR	1000	RoofStorage
SU1	NO	NO	79.029	84.029	5	TABULAR	1000	ExCB
SU10	NO	NO	80.6	85.6	5	TABULAR	1000	ExCBMH3
SU11_pr	NO	NO	79.9	84.9	5	TABULAR	1000	CB201/CB10
SU12_pr	NO	NO	80.1	85.1	5	TABULAR	1000	CB202/CB11
SU13_pr	NO	NO	79.95	84.95	5	TABULAR	1000	ExCB4
SU2	NO	NO	79.85	84.85	5	TABULAR	1000	ExCB3
SU3	NO	NO	79.86	84.86	5	TABULAR	1000	ExCBMH2
SU4	NO	NO	79.87	84.87	5	TABULAR	1000	ExCBMH1
SU5	NO	NO	79.93	84.93	5	TABULAR	1000	ExCB1
SU6	NO	NO	79.25	84.25	5	TABULAR	1000	DI01
SU7	NO	NO	79.41	84.41	5	TABULAR	1000	ExCB8
SU8	NO	NO	78.812	83.812	5	TABULAR	1000	ExCB6

E-3 PCSWMM Storage Summary

St. Patrick's Homes Ottawa - Storage Summary

Available Superpipe Storage

<i>Available superpipe storage (Novatech, 2011)</i>	132	m3
---	-----	----

Available Surface Storage

Subcatchment	Structure	Maximum Available Storage (m3)	Maximum Available Ponding depth (m)	Maximum Available Ponding Area (m2)	Limit of Highest Ponding Elevation (m)	Structure Top of Grate Elevation (m)
A5-1	EX CB 3	113	0.35	970.16	80.2	79.85
A5-2	EX CBMH 2	76	0.34	673.71	80.2	79.86
A5-3	EX CB 4	25	0.25	300.00	80.2	79.95
A5-4	EX CBMH 1	55	0.33	500.00	80.2	79.87
A5-5	CB 10/CB201	37	0.30	365.84	80.2	79.90
A5-6	CB 11/CB202	9	0.10	140.45	80.2	80.10
A5-7	EX CB 1	39	0.27	436.44	80.2	79.93
A5-8	LD's	n/a	n/a	n/a	n/a	n/a
A5-9	EX CBMH 3	100	0.35	830.00	80.95	80.60
A2_1 (rear yard)	DI01	60	0.30	600.00	n/a	79.25
A2_2 (rear yard)	ExCB6	20	0.30	200.00	n/a	78.83
A2_3	Ex-STM-MH	n/a	n/a	n/a	n/a	79.56
A2_4 (rear yard)	ExCB8	50	0.30	500.00	n/a	79.41
A2_5 (rear yard)	ExCB	20	0.30	200.00	n/a	79.03
<i>Total available surface storage</i>		605				

Utilized Surface Storage - 100 yr

Subcatchment	Structure	Maximum Storage from PCSWMM (m ³)	Maximum Depth of Ponding (m)	Highest Ponding Elevation (m)	Structure Top of Grate Elevation (m)
A5-1	EX CB 3	83	0.25	80.10	79.85
A5-2	EX CBMH 2	68	0.26	80.12	79.86
A5-3	EX CB 4	55	0.30	80.25	79.95
A5-4	EX CBMH 1	70	0.30	80.17	79.87
A5-5	CB 10/CB201	47	0.28	80.18	79.90
A5-6	CB 11/CB202	1	0.04	80.14	80.10
A5-7	EX CB 1	66	0.29	80.22	79.93
A5-8	LD's	n/a	n/a	n/a	n/a
A5-9	EX CBMH 3	5	0.06	80.66	80.60
A2_1 (rear yard)	DI01	1	0.03	79.28	79.25
A2_2 (rear yard)	ExCB6	0	0.01	78.83	78.83
A2_3	Ex-STM-MH	n/a	n/a	n/a	n/a
A2_4 (rear yard)	ExCB8	0	0.02	79.43	79.41
A2_5 (rear yard)	ExCB	0	0.01	79.04	79.03
<i>Total utilized surface storage - 100 yr</i>		396			

Available Roof Storage

Subcatchment	Structure	Maximum Available Storage (m3)	Maximum Available Ponding depth (m)	Maximum Available Ponding Area (m2)	Structure Top of Grate Elevation (m)
A5-B Roof	n/a	63	0.15	1264.54	n/a
<i>Total available roof storage</i>		63			

Utilized Roof Storage - 100 yr

Subcatchment	Structure	Storage (m3)	Ponding depth (m)	Ponding Elevation (m)	Structure Top of Grate Elevation (m)
A5-B Roof	n/a	56	0.12	n/a	n/a
<i>Total utilized roof storage - 100 yr</i>		56			

Existing Structure Storage (Novatech, 2011)

Name	Storage (m3)
Ex STM MH1	12
Ex STM MH2	12
Ex CB3	6
Ex CBMH2	2
Ex CB4	1
Ex CBMH1	2
Ex CB1	1
<i>Total existing surface storage</i>	36

Utilized Structure Storage - 100 yr

Structure area based on 1.2 m diameter = 1.13 m²

Name	Invert Elev. (m)	Max. HGL (m)	Storage (m ³)
CB201/CB10	78.30	79.90	2
CB202/CB11	78.50	80.10	2
CB203	78.98	80.95	2
DI01	78.20	78.30	0
ExCB	77.59	77.67	0
Ex-CB1	78.21	79.93	2
ExCB2	78.10	78.19	0
Ex-CB3	78.17	79.85	2
ExCB4	78.33	79.95	2
ExCB6	77.70	77.73	0
ExCB8	77.64	77.68	0
Ex-CBMH1	77.92	79.87	2
Ex-CBMH2	78.13	79.86	2
ExCBMH3	78.82	80.41	2
ExMH103/Ex STM MH2	77.41	80.18	3
ExSTMH	77.86	77.94	0
Ex-STMH1	77.81	80.15	3
Ex-STMH9	77.18	77.35	0
EX-STM-MH	76.63	76.74	0
J1	77.50	80.17	3
J17	77.53	80.16	3
J2	77.50	80.18	3
J20	77.51	80.17	3
J25	77.41	77.67	0
J26	77.32	77.65	0
J6	77.47	80.18	3
OGS-STMH201	77.39	77.51	0
STM01	78.23	78.30	0
STMMH202	77.37	77.51	0
STMMH203	77.81	77.88	0
<i>Total Available Structure Storage</i>			<i>40</i>

Available Storage (m³) vs Utilized Storage (m³)

Storage Type	Available Storage (m ³)	Utilized Storage (m ³) per PCSWMM Model
Superpipe	132	132
Inlets/Junctions	36	40
Pipes	Relatively negligible	
Roof	63	56
Surface Grading	605	396
Total	836	624

E-4 PCSWMM Model Output Files

EPA STORM WATER MANAGEMENT MODEL - VERSION 5.2 (Build 5.2.4)

WARNING 03: negative offset ignored for Link C2
 WARNING 08: elevation drop exceeds length for Conduit C3
 WARNING 03: negative offset ignored for Link OR1
 WARNING 08: elevation drop exceeds length for Conduit OR10
 WARNING 08: elevation drop exceeds length for Conduit OR11
 WARNING 08: elevation drop exceeds length for Conduit OR12
 WARNING 08: elevation drop exceeds length for Conduit OR2
 WARNING 08: elevation drop exceeds length for Conduit OR3
 WARNING 08: elevation drop exceeds length for Conduit OR4
 WARNING 03: negative offset ignored for Link OR6
 WARNING 03: negative offset ignored for Link OR7
 WARNING 03: negative offset ignored for Link OR8

Element Count

Number of rain gages 3
 Number of subcatchments ... 18
 Number of nodes 47
 Number of links 43
 Number of pollutants 0
 Number of land uses 0

Raingage Summary

Name	Data Source	Data Type	Recording Interval
Riverside_100year	Chicago_3h_100yr_10min	INTENSITY	10 min.
Riverside_100yr+20%	Chicago_3hr_100yr+20%_10min	INTENSITY	10 min.
Riverside_5Year	Chicago_3h_5yr_10min	INTENSITY	10 min.

Subcatchment Summary

Name	Area	Width	%Imperv	%Slope	Rain Gage
Outlet					
A1	0.15	55.19	13.15	0.7360	Riverside_100year
OF2					
A2_1	0.06	35.18	1.00	0.6420	Riverside_100year
SU6					
A2_2	0.02	19.50	1.00	0.6420	Riverside_100year
SU8					
A2_3	0.13	51.68	36.87	0.6420	Riverside_100year
EX-STM-MH					
A2_4	0.04	30.79	1.00	0.6420	Riverside_100year
SU7					
A2_5	0.01	15.38	1.00	0.6420	Riverside_100year
SU1					

A-3Ex OF4	0.27	73.89	25.00	0.5000	Riverside_100year
A-4EX OF3	0.35	84.05	25.00	0.5000	Riverside_100year
A5-1 SU2	0.12	48.62	96.60	1.0000	Riverside_100year
A5-2 SU3	0.09	44.76	100.00	1.0000	Riverside_100year
A5-3 SU13_pr	0.21	66.44	83.01	1.0000	Riverside_100year
A5-4 SU4	0.10	45.65	86.67	1.0000	Riverside_100year
A5-5 SU11_pr	0.08	40.53	75.03	1.0000	Riverside_100year
A5-6 SU12_pr	0.09	42.86	100.00	1.0000	Riverside_100year
A5-7 SU5	0.16	58.21	51.53	0.9600	Riverside_100year
A5-8 CB203	0.10	45.22	33.65	0.9620	Riverside_100year
A5-9 SU10	0.29	76.84	65.09	0.8680	Riverside_100year
A5-B-Roof Roof-Storage	0.14	54.23	100.00	1.0000	Riverside_100year

Node Summary

Name	Type	Invert Elev.	Max. Depth	Ponded Area	External Inflow
CB201	JUNCTION	78.30	1.60	0.0	
CB202	JUNCTION	78.50	1.60	0.0	
CB203	JUNCTION	78.98	1.97	0.0	
DI01	JUNCTION	78.20	1.05	0.0	
ExCB	JUNCTION	77.59	1.44	0.0	
Ex-CB1	JUNCTION	78.21	1.72	0.0	
ExCB2	JUNCTION	78.10	0.73	0.0	
Ex-CB3	JUNCTION	78.17	1.68	0.0	
ExCB4	JUNCTION	78.33	1.62	0.0	
ExCB6	JUNCTION	77.70	1.13	0.0	
ExCB8	JUNCTION	77.64	1.77	0.0	
Ex-CBMH1	JUNCTION	77.92	1.95	0.0	
Ex-CBMH2	JUNCTION	78.13	1.73	0.0	
ExCBMH3	JUNCTION	78.82	1.78	0.0	
ExMH103	JUNCTION	77.41	3.00	0.0	
ExSTMH	JUNCTION	77.86	2.26	0.0	
Ex-STMH1	JUNCTION	77.81	2.34	0.0	
Ex-STMH9	JUNCTION	77.18	3.24	0.0	
EX-STM-MH	JUNCTION	76.63	2.93	0.0	
J1	JUNCTION	77.50	2.68	0.0	
J17	JUNCTION	77.53	2.62	0.0	
J2	JUNCTION	77.50	2.80	0.0	
J20	JUNCTION	77.51	2.64	0.0	
J25	JUNCTION	77.41	1.43	0.0	
J26	JUNCTION	77.32	2.10	0.0	
J6	JUNCTION	77.47	2.89	0.0	

OGS-STMH201	JUNCTION	77.39	3.06	0.0
STM01	JUNCTION	78.23	5.00	0.0
STMMH202	JUNCTION	77.37	3.00	0.0
STMMH203	JUNCTION	77.81	3.12	0.0
OF1	OUTFALL	75.00	0.30	0.0
OF2	OUTFALL	0.00	0.00	0.0
OF3	OUTFALL	0.00	0.00	0.0
OF4	OUTFALL	0.00	0.00	0.0
Roof-Storage	STORAGE	88.23	0.15	0.0
SU1	STORAGE	79.03	5.00	0.0
SU10	STORAGE	80.60	5.00	0.0
SU11_pr	STORAGE	79.90	5.00	0.0
SU12_pr	STORAGE	80.10	5.00	0.0
SU13_pr	STORAGE	79.95	5.00	0.0
SU2	STORAGE	79.85	5.00	0.0
SU3	STORAGE	79.86	5.00	0.0
SU4	STORAGE	79.87	5.00	0.0
SU5	STORAGE	79.93	5.00	0.0
SU6	STORAGE	79.25	5.00	0.0
SU7	STORAGE	79.41	5.00	0.0
SU8	STORAGE	78.81	5.00	0.0

Link Summary

Name		From Node	To Node	Type	Length	%
Slope	Roughness					

C1		ExCB4	Ex-CBMH2	CONDUIT	31.4	
0.4459	0.0100					
C1_2		STMMH203	STMMH202	CONDUIT	35.5	
1.0127	0.0100					
C10		J17	J20	CONDUIT	13.5	
0.1114	0.0130					
C11		Ex-CB3	J20	CONDUIT	16.5	
0.3636	0.0130					
C12		CB202	J2	CONDUIT	10.8	
9.2992	0.0100					
C12_1		J20	J1	CONDUIT	6.1	
0.1149	0.0100					
C12_3		J1	J2	CONDUIT	20.0	
0.0150	0.0100					
C12_4		J2	J6	CONDUIT	9.5	
0.3173	0.0100					
C13		ExCBMH3	ExMH103	CONDUIT	43.7	
0.3433	0.0100					
C13_2		STMMH202	Ex-STMH9	CONDUIT	25.1	
0.6767	0.0130					
C13_6		OGS-STMH201	STMMH202	CONDUIT	1.6	
1.2588	0.0130					
C14		Ex-STMH9	EX-STM-MH	CONDUIT	51.7	
0.4836	0.0130					
C15		EX-STM-MH	OF1	CONDUIT	30.2	
5.4063	0.0130					
C17		DI01	ExCB2	CONDUIT	4.0	
1.0001	0.0130					

C18		ExCB2	ExSTMH	CONDUIT	20.9
1.0048	0.0130				
C19		ExSTMH	ExCB	CONDUIT	42.6
0.6337	0.0130				
C2		STM01	STMMH203	CONDUIT	18.4
1.9569	0.0130				
C20		ExCB	J25	CONDUIT	15.4
1.1556	0.0130				
C21		J25	J26	CONDUIT	68.3
0.1304	0.0130				
C22		J26	Ex-STMH9	CONDUIT	18.0
0.8152	0.0130				-
C23		ExCB6	J25	CONDUIT	3.2
9.0367	0.0130				
C24		ExCB8	J26	CONDUIT	4.6
6.9077	0.0130				
C3		SU13_pr	ExCB4	CONDUIT	1.5
121.7448	0.0100				
C4		CB201	J1	CONDUIT	10.7
7.5046	0.0100				
C4_2		CB203	ExCBMH3	CONDUIT	19.4
0.5155	0.0100				
C5		J6	ExMH103	CONDUIT	25.9
0.0773	0.0130				
C6		Ex-CBMH2	J6	CONDUIT	16.5
0.3636	0.0130				
C7		Ex-STMH1	J17	CONDUIT	2.6
11.1583	0.0130				
C8		Ex-CB1	Ex-CBMH1	CONDUIT	58.4
0.4452	0.0130				
C9		Ex-CBMH1	J17	CONDUIT	22.5
1.7558	0.0130				
OR1		SU1	ExCB	CONDUIT	2.0
100.0052	0.0100				
OR10		SU10	ExCBMH3	CONDUIT	1.5
138.1323	0.0100				
OR11		SU11_pr	CB201	CONDUIT	1.5
126.1620	0.0100				
OR12		SU12_pr	CB202	CONDUIT	1.5
114.4781	0.0100				
OR2		SU2	Ex-CB3	CONDUIT	1.7
118.2984	0.0100				
OR3		SU3	Ex-CBMH2	CONDUIT	1.7
121.5502	0.0100				
OR4		SU4	Ex-CBMH1	CONDUIT	1.9
118.3801	0.0100				
OR5		SU5	Ex-CB1	CONDUIT	3.3
73.8777	0.0100				
OR6		SU6	DI01	CONDUIT	2.9
38.3256	0.0100				
OR7		SU7	ExCB8	CONDUIT	2.0
188.3495	0.0100				
OR8		SU8	ExCB6	CONDUIT	1.4
121.7519	0.0100				
C13_5		ExMH103	OGS-STMH201	ORIFICE	
C16		Roof-Storage	STM01	ORIFICE	

Cross Section Summary

Full Conduit Flow	Shape	Full Depth	Full Area	Hyd. Rad.	Max. Width	No. of Barrels
C1 0.05	CIRCULAR	0.25	0.05	0.06	0.25	1
C1_2 0.08	CIRCULAR	0.25	0.05	0.06	0.25	1
C10 2.36	CIRCULAR	1.50	1.77	0.38	1.50	1
C11 0.06	CIRCULAR	0.30	0.07	0.07	0.30	1
C12 0.24	CIRCULAR	0.25	0.05	0.06	0.25	1
C12_1 3.12	CIRCULAR	1.50	1.77	0.38	1.50	1
C12_3 1.12	CIRCULAR	1.50	1.77	0.38	1.50	1
C12_4 5.18	CIRCULAR	1.50	1.77	0.38	1.50	1
C13 0.07	CIRCULAR	0.30	0.07	0.07	0.30	1
C13_2 0.14	CIRCULAR	0.38	0.11	0.09	0.38	1
C13_6 0.20	CIRCULAR	0.38	0.11	0.09	0.38	1
C14 0.12	CIRCULAR	0.38	0.11	0.09	0.38	1
C15 0.22	CIRCULAR	0.30	0.07	0.07	0.30	1
C17 0.03	CIRCULAR	0.20	0.03	0.05	0.20	1
C18 0.03	CIRCULAR	0.20	0.03	0.05	0.20	1
C19 0.08	CIRCULAR	0.30	0.07	0.07	0.30	1
C2 0.08	CIRCULAR	0.25	0.05	0.06	0.25	1
C20 0.10	CIRCULAR	0.30	0.07	0.07	0.30	1
C21 0.03	CIRCULAR	0.30	0.07	0.07	0.30	1
C22 0.09	CIRCULAR	0.30	0.07	0.07	0.30	1
C23 0.10	CIRCULAR	0.20	0.03	0.05	0.20	1
C24 0.09	CIRCULAR	0.20	0.03	0.05	0.20	1
C3 0.85	CIRCULAR	0.25	0.05	0.06	0.25	1
C4 0.21	CIRCULAR	0.25	0.05	0.06	0.25	1
C4_2 0.06	CIRCULAR	0.25	0.05	0.06	0.25	1
C5 1.97	CIRCULAR	1.50	1.77	0.38	1.50	1
C6	CIRCULAR	0.30	0.07	0.07	0.30	1

C7	CIRCULAR	1.50	1.77	0.38	1.50	1
23.62						
C8	CIRCULAR	0.25	0.05	0.06	0.25	1
0.04						
C9	CIRCULAR	0.30	0.07	0.07	0.30	1
0.13						
OR1	CIRCULAR	0.25	0.05	0.06	0.25	1
0.77						
OR10	CIRCULAR	0.25	0.05	0.06	0.25	1
0.91						
OR11	CIRCULAR	0.25	0.05	0.06	0.25	1
0.87						
OR12	CIRCULAR	0.25	0.05	0.06	0.25	1
0.83						
OR2	CIRCULAR	0.25	0.05	0.06	0.25	1
0.84						
OR3	CIRCULAR	0.25	0.05	0.06	0.25	1
0.85						
OR4	CIRCULAR	0.25	0.05	0.06	0.25	1
0.84						
OR5	CIRCULAR	0.25	0.05	0.06	0.25	1
0.66						
OR6	CIRCULAR	0.25	0.05	0.06	0.25	1
0.48						
OR7	CIRCULAR	0.25	0.05	0.06	0.25	1
1.06						
OR8	CIRCULAR	0.25	0.05	0.06	0.25	1
0.85						

Analysis Options

Flow Units CMS
Process Models:
 Rainfall/Runoff YES
 RDII NO
 Snowmelt NO
 Groundwater NO
 Flow Routing YES
 Ponding Allowed NO
 Water Quality NO
Infiltration Method HORTON
Flow Routing Method DYNWAVE
Surcharge Method EXTRAN
Starting Date 06/11/2024 00:00:00
Ending Date 06/12/2024 00:00:00
Antecedent Dry Days 0.0
Report Time Step 00:01:00
Wet Time Step 00:05:00
Dry Time Step 00:05:00
Routing Time Step 5.00 sec
Variable Time Step YES
Maximum Trials 8
Number of Threads 8
Head Tolerance 0.001524 m

```

*****
Runoff Quantity Continuity      Volume      Depth
                                hectare-m    mm
*****
Total Precipitation .....      0.174      71.677
Evaporation Loss .....          0.000      0.000
Infiltration Loss .....         0.053      21.912
Surface Runoff .....            0.119      48.787
Final Storage .....             0.000      0.113
Continuity Error (%) .....      1.207

```

```

*****
Flow Routing Continuity      Volume      Volume
                                hectare-m    10^6 ltr
*****
Dry Weather Inflow .....        0.000      0.000
Wet Weather Inflow .....        0.119      1.186
Groundwater Inflow .....         0.000      0.000
RDII Inflow .....               0.000      0.000
External Inflow .....            0.000      0.000
External Outflow .....           0.067      0.674
Flooding Loss .....              0.000      0.000
Evaporation Loss .....           0.000      0.000
Exfiltration Loss .....          0.000      0.000
Initial Stored Volume ....        0.000      0.001
Final Stored Volume .....         0.054      0.535
Continuity Error (%) .....      -1.811

```

```

*****
Highest Continuity Errors
*****
Node J17 (-21.15%)
Node Ex-CB3 (-5.57%)
Node J26 (3.26%)
Node CB201 (-2.78%)
Node J20 (-1.78%)

```

```

*****
Time-Step Critical Elements
*****
Link C13_6 (64.06%)
Link C3 (13.39%)
Link OR12 (8.75%)

```

```

*****
Highest Flow Instability Indexes
*****
Link C7 (18)
Link C12_1 (9)
Link C10 (9)
Link C12_4 (8)
Link C5 (7)

```

```

*****

```

Most Frequent Nonconverging Nodes

Node OF1 (3.56%)
 Node OF2 (3.56%)
 Node OF3 (3.56%)
 Node OF4 (3.56%)
 Node ExCB4 (2.01%)

Routing Time Step Summary

Minimum Time Step : 0.50 sec
 Average Time Step : 1.60 sec
 Maximum Time Step : 5.00 sec
 % of Time in Steady State : 0.00
 Average Iterations per Step : 2.38
 % of Steps Not Converging : 3.56
 Time Step Frequencies :
 5.000 - 3.155 sec : 13.02 %
 3.155 - 1.991 sec : 1.04 %
 1.991 - 1.256 sec : 15.32 %
 1.256 - 0.792 sec : 58.50 %
 0.792 - 0.500 sec : 12.12 %

Subcatchment Runoff Summary

Perv	Total	Total	Total	Total	Total	Total	Imperv
Runoff	Runoff	Total	Peak	Runoff	Evap	Infil	Runoff
Subcatchment	Runoff	Precip	Runoff	Runon	mm	mm	mm
mm	mm	mm	mm	Coeff			

		10^6 ltr	CMS				
A1		71.68	0.00	0.00	40.94	9.43	
21.79	9.43	0.01	0.01	0.132			
A2_1		71.68	0.00	0.00	45.93	0.71	
25.71	26.42	0.02	0.01	0.369			
A2_2		71.68	0.00	0.00	44.91	0.71	
27.08	27.79	0.01	0.01	0.388			
A2_3		71.68	0.00	0.00	29.19	26.24	
16.51	42.75	0.06	0.04	0.596			
A2_4		71.68	0.00	0.00	45.51	0.71	
26.24	26.96	0.01	0.01	0.376			
A2_5		71.68	0.00	0.00	44.60	0.71	
27.57	28.29	0.00	0.00	0.395			
A-3Ex		71.68	0.00	0.00	36.10	17.67	
17.97	35.64	0.09	0.06	0.497			
A-4EX		71.68	0.00	0.00	36.52	17.68	
17.50	35.18	0.12	0.07	0.491			
A5-1		71.68	0.00	0.00	1.49	69.58	
1.10	70.68	0.08	0.06	0.986			

A5-2		71.68	0.00	0.00	0.00	71.99
0.00	71.99	0.07	0.05	1.004		
A5-3		71.68	0.00	0.00	7.56	59.82
4.94	64.76	0.14	0.10	0.904		
A5-4		71.68	0.00	0.00	5.88	62.38
4.03	66.41	0.07	0.05	0.927		
A5-5		71.68	0.00	0.00	11.08	53.93
7.33	61.26	0.05	0.04	0.855		
A5-6		71.68	0.00	0.00	0.00	71.99
0.00	71.99	0.06	0.04	1.004		
A5-7		71.68	0.00	0.00	22.08	37.05
13.12	50.17	0.08	0.06	0.700		
A5-8		71.68	0.00	0.00	30.36	24.15
17.77	41.93	0.04	0.03	0.585		
A5-9		71.68	0.00	0.00	15.92	46.71
9.43	56.14	0.16	0.12	0.783		
A5-B-Roof		71.68	0.00	0.00	0.00	72.06
0.00	72.06	0.10	0.07	1.005		

Node Depth Summary

Node	Type	Average Depth Meters	Maximum Depth Meters	Maximum HGL Meters	Time of Max Occurrence days hr:min	Reported Max Depth Meters
CB201	JUNCTION	0.27	1.24	79.54	0 02:34	1.24
CB202	JUNCTION	0.19	1.04	79.54	0 02:34	1.04
CB203	JUNCTION	0.07	0.56	79.54	0 02:34	0.56
DI01	JUNCTION	0.01	0.10	78.30	0 01:11	0.10
ExCB	JUNCTION	0.01	0.08	77.67	0 01:13	0.08
Ex-CB1	JUNCTION	0.31	1.33	79.54	0 02:34	1.33
ExCB2	JUNCTION	0.01	0.09	78.19	0 01:11	0.09
Ex-CB3	JUNCTION	0.33	1.37	79.54	0 02:34	1.37
ExCB4	JUNCTION	0.26	1.21	79.54	0 02:34	1.21
ExCB6	JUNCTION	0.00	0.03	77.73	0 01:10	0.03
ExCB8	JUNCTION	0.00	0.04	77.68	0 01:10	0.04
Ex-CBMH1	JUNCTION	0.47	1.62	79.54	0 02:34	1.62
Ex-CBMH2	JUNCTION	0.36	1.41	79.54	0 02:34	1.41
ExCBMH3	JUNCTION	0.11	0.72	79.54	0 02:34	0.72
ExMH103	JUNCTION	0.85	2.13	79.54	0 02:34	2.13
ExSTMH	JUNCTION	0.01	0.08	77.94	0 01:12	0.08
Ex-STMH1	JUNCTION	0.54	1.73	79.54	0 02:34	1.73
Ex-STMH9	JUNCTION	0.06	0.16	77.34	0 01:15	0.16
EX-STM-MH	JUNCTION	0.04	0.11	76.74	0 01:13	0.11
J1	JUNCTION	0.77	2.04	79.54	0 02:34	2.04
J17	JUNCTION	0.76	2.02	79.54	0 02:34	2.02
J2	JUNCTION	0.78	2.04	79.54	0 02:34	2.04
J20	JUNCTION	0.77	2.03	79.54	0 02:34	2.03
J25	JUNCTION	0.07	0.25	77.67	0 01:13	0.25
J26	JUNCTION	0.15	0.32	77.65	0 01:13	0.32
J6	JUNCTION	0.80	2.07	79.54	0 02:34	2.07
OGS-STMH201	JUNCTION	0.06	0.11	77.50	0 01:35	0.11
STM01	JUNCTION	0.02	0.07	78.30	0 01:24	0.07
STMMH202	JUNCTION	0.08	0.13	77.50	0 01:34	0.13

STMMH203	JUNCTION	0.02	0.07	77.88	0	01:25	0.07
OF1	OUTFALL	0.30	0.30	75.30	0	00:00	0.30
OF2	OUTFALL	0.00	0.00	0.00	0	00:00	0.00
OF3	OUTFALL	0.00	0.00	0.00	0	00:00	0.00
OF4	OUTFALL	0.00	0.00	0.00	0	00:00	0.00
Roof-Storage	STORAGE	0.03	0.12	88.35	0	01:24	0.12
SU1	STORAGE	0.00	0.01	79.04	0	01:10	0.01
SU10	STORAGE	0.28	0.30	80.90	1	00:00	0.30
SU11_pr	STORAGE	0.26	0.28	80.18	1	00:00	0.28
SU12_pr	STORAGE	0.10	0.14	80.24	0	01:10	0.14
SU13_pr	STORAGE	0.25	0.30	80.25	0	01:11	0.30
SU2	STORAGE	0.23	0.25	80.10	1	00:00	0.25
SU3	STORAGE	0.24	0.26	80.12	1	00:00	0.26
SU4	STORAGE	0.28	0.30	80.17	1	00:00	0.30
SU5	STORAGE	0.26	0.29	80.22	0	01:43	0.29
SU6	STORAGE	0.00	0.03	79.28	0	01:11	0.03
SU7	STORAGE	0.00	0.02	79.43	0	01:10	0.02
SU8	STORAGE	0.00	0.01	78.83	0	01:10	0.01

Node Inflow Summary

Total Inflow Volume		Flow Balance Error	Type	Maximum Lateral Inflow	Maximum Total Inflow	Time of Max Occurrence	Lateral Inflow Volume
ltr	Percent			CMS	CMS	days hr:min	10^6 ltr
0.000777	-2.701		JUNCTION	0.000	0.002	0 01:23	0
0.0614	-0.015		JUNCTION	0.000	0.045	0 01:10	0
0.0438	0.075		JUNCTION	0.034	0.034	0 01:10	0.0436
0.0158	0.005		JUNCTION	0.000	0.011	0 01:11	0
0.0193	-0.086		JUNCTION	0.000	0.014	0 01:11	0
0.0243	-0.049		JUNCTION	0.000	0.007	0 01:15	0
0.0158	0.004		JUNCTION	0.000	0.011	0 01:11	0
0.00109	-5.276		JUNCTION	0.000	0.004	0 01:13	0
0.1	0.702		JUNCTION	0.000	0.085	0 01:11	0
0.00542	0.001		JUNCTION	0.000	0.005	0 01:10	0
0.0116	0.001		JUNCTION	0.000	0.010	0 01:10	0
			JUNCTION	0.000	0.014	0 01:11	0
			JUNCTION	0.000	0.014	0 01:11	0

Ex-CBMH2		JUNCTION	0.000	0.085	0	01:11	0
0.0995	-0.084						
ExCBMH3		JUNCTION	0.000	0.033	0	01:10	0
0.0448	0.282						
ExMH103		JUNCTION	0.000	0.033	0	01:10	0
0.254	0.004						
ExSTMH		JUNCTION	0.000	0.011	0	01:11	0
0.0158	0.015						
Ex-STMH1		JUNCTION	0.000	0.176	0	04:00	0
0.00439	-53.491						
Ex-STMH9		JUNCTION	0.000	0.041	0	01:14	0
0.388	-0.034						
EX-STM-MH		JUNCTION	0.041	0.065	0	01:13	0.0552
0.44	0.001						
J1		JUNCTION	0.000	0.078	0	01:11	0
0.143	-1.627						
J17		JUNCTION	0.000	0.141	0	03:59	0
0.058	-17.460						
J2		JUNCTION	0.000	0.104	0	01:11	0
0.207	-0.324						
J20		JUNCTION	0.000	0.098	0	03:33	0
0.102	-1.752						
J25		JUNCTION	0.000	0.019	0	01:11	0
0.0294	1.541						
J26		JUNCTION	0.000	0.025	0	01:13	0
0.0441	3.374						
J6		JUNCTION	0.000	0.094	0	01:11	0
0.251	0.114						
OGS-STMH201		JUNCTION	0.000	0.008	0	02:34	0
0.249	0.006						
STM01		JUNCTION	0.000	0.012	0	01:24	0
0.102	0.000						
STMMH202		JUNCTION	0.000	0.019	0	01:34	0
0.35	-0.005						
STMMH203		JUNCTION	0.000	0.012	0	01:24	0
0.102	0.003						
OF1		OUTFALL	0.000	0.065	0	01:13	0
0.44	0.000						
OF2		OUTFALL	0.010	0.010	0	01:05	0.0143
0.0143	0.000						
OF3		OUTFALL	0.074	0.074	0	01:10	0.124
0.124	0.000						
OF4		OUTFALL	0.059	0.059	0	01:10	0.0948
0.0948	0.000						
Roof-Storage		STORAGE	0.070	0.070	0	01:10	0.102
0.102	0.001						
SU1		STORAGE	0.004	0.004	0	01:10	0.00348
0.00348	-0.007						
SU10		STORAGE	0.120	0.120	0	01:10	0.164
0.164	0.012						
SU11_pr		STORAGE	0.036	0.036	0	01:10	0.0472
0.0472	0.012						
SU12_pr		STORAGE	0.045	0.045	0	01:10	0.0648
0.0648	-0.001						
SU13_pr		STORAGE	0.101	0.101	0	01:10	0.138
0.138	0.003						
SU2		STORAGE	0.058	0.058	0	01:10	0.0834
0.0834	0.012						
SU3		STORAGE	0.047	0.047	0	01:10	0.0677
0.0677	0.012						

SU4		STORAGE	0.051	0.051	0	01:10	0.0697
0.0697	0.012						
SU5		STORAGE	0.062	0.062	0	01:10	0.0818
0.0818	0.009						
SU6		STORAGE	0.012	0.012	0	01:10	0.0158
0.0158	0.000						
SU7		STORAGE	0.010	0.010	0	01:10	0.0116
0.0116	0.000						
SU8		STORAGE	0.005	0.005	0	01:10	0.00542
0.00542	0.000						

Node Surcharge Summary

Surcharging occurs when water rises above the top of the highest conduit.

Node	Type	Hours Surcharged	Max. Height Above Crown Meters	Min. Depth Below Rim Meters
CB201	JUNCTION	4.84	0.990	0.360
CB202	JUNCTION	3.67	0.791	0.559
CB203	JUNCTION	2.06	0.310	1.410
Ex-CB1	JUNCTION	5.42	1.081	0.389
Ex-CB3	JUNCTION	5.35	1.070	0.310
ExCB4	JUNCTION	4.80	0.961	0.409
Ex-CBMH1	JUNCTION	7.29	1.321	0.329
Ex-CBMH2	JUNCTION	5.67	1.101	0.319
ExCBMH3	JUNCTION	2.22	0.410	1.060
ExMH103	JUNCTION	2.61	0.570	0.870
Ex-STMH1	JUNCTION	1.94	0.230	0.610
J1	JUNCTION	2.49	0.537	0.646
J17	JUNCTION	2.44	0.515	0.610
J2	JUNCTION	2.50	0.540	0.764
J20	JUNCTION	2.47	0.530	0.610
J26	JUNCTION	0.10	0.023	1.774
J6	JUNCTION	2.61	0.570	0.820

Node Flooding Summary

No nodes were flooded.

Storage Volume Summary

Max Occurrence	Maximum Outflow	Average Volume	Avg Pcnt	Evap Pcnt	Exfil Pcnt	Maximum Volume	Max Pcnt	Time of
----------------	-----------------	----------------	----------	-----------	------------	----------------	----------	---------

Storage Unit hr:min	Unit CMS	1000 m ³	Full	Loss	Loss	1000 m ³	Full	days
Roof-Storage		0.009	9.6	0.0	0.0	0.056	58.8	0
01:24	0.012							
SU1		0.000	0.0	0.0	0.0	0.000	0.0	0
01:10	0.004							
SU10		0.149	0.3	0.0	0.0	0.164	0.4	1
00:00	0.000							
SU11_pr		0.043	0.3	0.0	0.0	0.047	0.3	1
00:00	0.000							
SU12_pr		0.004	0.0	0.0	0.0	0.007	0.1	0
01:10	0.045							
SU13_pr		0.037	0.2	0.0	0.0	0.055	0.4	0
01:11	0.085							
SU2		0.076	0.2	0.0	0.0	0.083	0.2	1
00:00	0.000							
SU3		0.061	0.2	0.0	0.0	0.068	0.3	1
00:00	0.000							
SU4		0.063	0.3	0.0	0.0	0.070	0.4	1
00:00	0.000							
SU5		0.056	0.3	0.0	0.0	0.066	0.3	0
01:43	0.006							
SU6		0.000	0.0	0.0	0.0	0.001	0.0	0
01:11	0.011							
SU7		0.000	0.0	0.0	0.0	0.000	0.0	0
01:10	0.010							
SU8		0.000	0.0	0.0	0.0	0.000	0.0	0
01:10	0.005							

 Outfall Loading Summary

Outfall Node	Flow Freq Pcnt	Avg Flow CMS	Max Flow CMS	Total Volume 10 ⁶ ltr
OF1	87.35	0.011	0.065	0.440
OF2	24.74	0.002	0.010	0.014
OF3	27.18	0.014	0.074	0.124
OF4	26.53	0.011	0.059	0.095
System	41.45	0.039	0.200	0.674

 Link Flow Summary

Link	Type	Maximum Flow CMS	Time of Max Occurrence days hr:min	Maximum Veloc m/sec	Max/ Full Flow	Max/ Full Depth
------	------	--------------------------	--	-----------------------------	----------------------	-----------------------

C1	CONDUIT	0.085	0	01:11	1.72	1.64	1.00
C1_2	CONDUIT	0.012	0	01:25	1.12	0.16	0.28
C10	CONDUIT	0.098	0	03:33	0.12	0.04	1.00
C11	CONDUIT	0.004	0	01:13	0.20	0.07	1.00
C12	CONDUIT	0.045	0	01:10	1.60	0.19	1.00
C12_1	CONDUIT	0.068	0	03:33	0.13	0.02	1.00
C12_3	CONDUIT	0.078	0	01:11	0.18	0.07	1.00
C12_4	CONDUIT	0.065	0	01:11	0.28	0.01	1.00
C13	CONDUIT	0.033	0	01:10	0.88	0.44	1.00
C13_2	CONDUIT	0.019	0	01:34	0.85	0.13	0.27
C13_6	CONDUIT	0.008	0	02:34	0.36	0.04	0.32
C14	CONDUIT	0.041	0	01:15	0.96	0.34	0.41
C15	CONDUIT	0.065	0	01:13	1.26	0.29	0.68
C17	CONDUIT	0.011	0	01:11	0.81	0.34	0.45
C18	CONDUIT	0.011	0	01:11	0.91	0.34	0.41
C19	CONDUIT	0.011	0	01:12	0.77	0.15	0.26
C2	CONDUIT	0.012	0	01:24	1.17	0.15	0.27
C20	CONDUIT	0.014	0	01:12	0.52	0.14	0.55
C21	CONDUIT	0.018	0	01:14	0.26	0.50	0.92
C22	CONDUIT	0.025	0	01:13	0.67	0.29	0.68
C23	CONDUIT	0.005	0	01:10	0.68	0.05	0.58
C24	CONDUIT	0.010	0	01:10	0.56	0.11	0.61
C3	CONDUIT	0.085	0	01:11	3.50	0.10	0.61
C4	CONDUIT	0.002	0	01:23	0.06	0.01	1.00
C4_2	CONDUIT	0.033	0	01:10	1.04	0.60	1.00
C5	CONDUIT	0.016	0	03:33	0.09	0.01	1.00
C6	CONDUIT	0.085	0	01:11	1.29	1.45	1.00
C7	CONDUIT	0.176	0	04:00	0.10	0.01	1.00
C8	CONDUIT	0.007	0	01:15	0.22	0.19	1.00
C9	CONDUIT	0.014	0	01:11	0.26	0.11	1.00
OR1	CONDUIT	0.004	0	01:10	0.94	0.00	0.18
OR10	CONDUIT	0.000	0	00:00	0.00	0.00	0.50
OR11	CONDUIT	0.000	0	00:00	0.00	0.00	0.50
OR12	CONDUIT	0.045	0	01:10	5.35	0.05	0.53
OR2	CONDUIT	0.000	0	00:00	0.00	0.00	0.50
OR3	CONDUIT	0.000	0	00:00	0.00	0.00	0.50
OR4	CONDUIT	0.000	0	00:00	0.00	0.00	0.50
OR5	CONDUIT	0.006	0	01:43	0.21	0.01	0.53
OR6	CONDUIT	0.011	0	01:11	1.14	0.02	0.25
OR7	CONDUIT	0.010	0	01:10	2.74	0.01	0.12
OR8	CONDUIT	0.005	0	01:10	2.37	0.01	0.09
C13_5	ORIFICE	0.008	0	02:34			1.00
C16	ORIFICE	0.012	0	01:24			0.58

Flow Classification Summary

Inlet Conduit Ctrl	Adjusted /Actual Length	----- Fraction of Time in Flow Class -----							Norm Ltd
		Dry	Dry	Dry	Crit	Crit	Crit	Crit	
		Up	Down	Sub	Sup	Up	Down		

C9	1.00	0.04	0.01	0.00	0.75	0.21	0.00	0.00	0.13
0.00									
OR1	1.00	0.83	0.04	0.00	0.11	0.02	0.00	0.00	0.98
0.00									
OR10	1.00	0.01	0.99	0.00	0.00	0.00	0.00	0.00	0.00
0.00									
OR11	1.00	0.72	0.28	0.00	0.00	0.00	0.00	0.00	0.00
0.00									
OR12	1.00	0.03	0.00	0.00	0.94	0.03	0.00	0.00	0.97
0.00									
OR2	1.00	0.05	0.95	0.00	0.00	0.00	0.00	0.00	0.00
0.00									
OR3	1.00	0.05	0.95	0.00	0.00	0.00	0.00	0.00	0.00
0.00									
OR4	1.00	0.05	0.95	0.00	0.00	0.00	0.00	0.00	0.00
0.00									
OR5	1.00	0.05	0.01	0.00	0.84	0.10	0.00	0.00	0.94
0.00									
OR6	1.00	0.01	0.86	0.00	0.01	0.12	0.00	0.00	0.99
0.00									
OR7	1.00	0.01	0.00	0.00	0.87	0.12	0.00	0.00	0.99
0.00									
OR8	1.00	0.01	0.00	0.00	0.87	0.12	0.00	0.00	0.98
0.00									

 Conduit Surcharge Summary

Conduit	Hours Full			Hours	
	Both Ends	Upstream	Dnstream	Above Full Normal Flow	Capacity Limited
C1	4.79	4.80	5.67	0.12	0.08
C10	2.43	2.43	2.47	0.01	0.10
C11	5.35	5.35	5.78	0.01	0.01
C12	3.67	3.67	22.90	0.01	0.01
C12_1	2.47	2.47	2.49	0.01	0.26
C12_3	2.49	2.49	2.50	0.01	0.47
C12_4	2.50	2.50	2.61	0.01	0.01
C13	2.23	2.23	2.61	0.01	0.01
C15	0.01	0.01	23.83	0.01	0.01
C21	0.01	0.01	0.10	0.01	0.01
C22	0.01	0.01	0.10	0.01	0.01
C23	0.01	0.01	0.20	0.01	0.01
C24	0.01	0.01	0.67	0.01	0.01
C3	0.01	0.01	4.80	0.01	0.01
C4	4.84	4.84	22.75	0.01	0.01
C4_2	2.06	2.06	2.22	0.01	0.01
C5	2.61	2.61	2.69	0.01	0.01
C6	5.66	5.75	6.09	0.10	0.01
C7	1.94	1.94	2.43	0.01	0.01
C8	5.42	5.42	7.45	0.01	0.01
C9	7.29	7.29	10.50	0.01	0.01
OR12	0.01	0.01	3.67	0.01	0.01
OR5	0.01	0.01	5.36	0.01	0.01

Analysis begun on: Mon Jun 24 16:00:08 2024
Analysis ended on: Mon Jun 24 16:00:09 2024
Total elapsed time: 00:00:01

EPA STORM WATER MANAGEMENT MODEL - VERSION 5.2 (Build 5.2.4)

WARNING 03: negative offset ignored for Link C2
 WARNING 08: elevation drop exceeds length for Conduit C3
 WARNING 03: negative offset ignored for Link OR1
 WARNING 08: elevation drop exceeds length for Conduit OR10
 WARNING 08: elevation drop exceeds length for Conduit OR11
 WARNING 08: elevation drop exceeds length for Conduit OR12
 WARNING 08: elevation drop exceeds length for Conduit OR2
 WARNING 08: elevation drop exceeds length for Conduit OR3
 WARNING 08: elevation drop exceeds length for Conduit OR4
 WARNING 03: negative offset ignored for Link OR6
 WARNING 03: negative offset ignored for Link OR7
 WARNING 03: negative offset ignored for Link OR8

Element Count

Number of rain gages 3
 Number of subcatchments ... 18
 Number of nodes 47
 Number of links 43
 Number of pollutants 0
 Number of land uses 0

Raingage Summary

Name	Data Source	Data Type	Recording Interval
Riverside_100year	Chicago_3h_100yr_10min	INTENSITY	10 min.
Riverside_100yr+20%	Chicago_3hr_100yr+20%_10min	INTENSITY	10 min.
Riverside_5Year	Chicago_3h_5yr_10min	INTENSITY	10 min.

Subcatchment Summary

Name	Area	Width	%Imperv	%Slope	Rain Gage
Outlet					
A1	0.15	55.19	13.15	0.7360	Riverside_5Year
OF2					
A2_1	0.06	35.18	1.00	0.6420	Riverside_5Year
SU6					
A2_2	0.02	19.50	1.00	0.6420	Riverside_5Year
SU8					
A2_3	0.13	51.68	36.87	0.6420	Riverside_5Year
EX-STM-MH					
A2_4	0.04	30.79	1.00	0.6420	Riverside_5Year
SU7					
A2_5	0.01	15.38	1.00	0.6420	Riverside_5Year
SU1					

A-3Ex OF4	0.27	73.89	25.00	0.5000	Riverside_5Year
A-4EX OF3	0.35	84.05	25.00	0.5000	Riverside_5Year
A5-1 SU2	0.12	48.62	96.60	1.0000	Riverside_5Year
A5-2 SU3	0.09	44.76	100.00	1.0000	Riverside_5Year
A5-3 SU13_pr	0.21	66.44	83.01	1.0000	Riverside_5Year
A5-4 SU4	0.10	45.65	86.67	1.0000	Riverside_5Year
A5-5 SU11_pr	0.08	40.53	75.03	1.0000	Riverside_5Year
A5-6 SU12_pr	0.09	42.86	100.00	1.0000	Riverside_5Year
A5-7 SU5	0.16	58.21	51.53	0.9600	Riverside_5Year
A5-8 CB203	0.10	45.22	33.65	0.9620	Riverside_5Year
A5-9 SU10	0.29	76.84	65.09	0.8680	Riverside_5Year
A5-B-Roof Roof-Storage	0.14	54.23	100.00	1.0000	Riverside_5Year

Node Summary

Name	Type	Invert Elev.	Max. Depth	Ponded Area	External Inflow
CB201	JUNCTION	78.30	1.60	0.0	
CB202	JUNCTION	78.50	1.60	0.0	
CB203	JUNCTION	78.98	1.97	0.0	
DI01	JUNCTION	78.20	1.05	0.0	
ExCB	JUNCTION	77.59	1.44	0.0	
Ex-CB1	JUNCTION	78.21	1.72	0.0	
ExCB2	JUNCTION	78.10	0.73	0.0	
Ex-CB3	JUNCTION	78.17	1.68	0.0	
ExCB4	JUNCTION	78.33	1.62	0.0	
ExCB6	JUNCTION	77.70	1.13	0.0	
ExCB8	JUNCTION	77.64	1.77	0.0	
Ex-CBMH1	JUNCTION	77.92	1.95	0.0	
Ex-CBMH2	JUNCTION	78.13	1.73	0.0	
ExCBMH3	JUNCTION	78.82	1.78	0.0	
ExMH103	JUNCTION	77.41	3.00	0.0	
ExSTMH	JUNCTION	77.86	2.26	0.0	
Ex-STMH1	JUNCTION	77.81	2.34	0.0	
Ex-STMH9	JUNCTION	77.18	3.24	0.0	
EX-STM-MH	JUNCTION	76.63	2.93	0.0	
J1	JUNCTION	77.50	2.68	0.0	
J17	JUNCTION	77.53	2.62	0.0	
J2	JUNCTION	77.50	2.80	0.0	
J20	JUNCTION	77.51	2.64	0.0	
J25	JUNCTION	77.41	1.43	0.0	
J26	JUNCTION	77.32	2.10	0.0	
J6	JUNCTION	77.47	2.89	0.0	

OGS-STMH201	JUNCTION	77.39	3.06	0.0
STM01	JUNCTION	78.23	5.00	0.0
STMMH202	JUNCTION	77.37	3.00	0.0
STMMH203	JUNCTION	77.81	3.12	0.0
OF1	OUTFALL	75.00	0.30	0.0
OF2	OUTFALL	0.00	0.00	0.0
OF3	OUTFALL	0.00	0.00	0.0
OF4	OUTFALL	0.00	0.00	0.0
Roof-Storage	STORAGE	88.23	0.15	0.0
SU1	STORAGE	79.03	5.00	0.0
SU10	STORAGE	80.60	5.00	0.0
SU11_pr	STORAGE	79.90	5.00	0.0
SU12_pr	STORAGE	80.10	5.00	0.0
SU13_pr	STORAGE	79.95	5.00	0.0
SU2	STORAGE	79.85	5.00	0.0
SU3	STORAGE	79.86	5.00	0.0
SU4	STORAGE	79.87	5.00	0.0
SU5	STORAGE	79.93	5.00	0.0
SU6	STORAGE	79.25	5.00	0.0
SU7	STORAGE	79.41	5.00	0.0
SU8	STORAGE	78.81	5.00	0.0

Link Summary

Name		From Node	To Node	Type	Length	%
Slope	Roughness					

C1		ExCB4	Ex-CBMH2	CONDUIT	31.4	
0.4459	0.0100					
C1_2		STMMH203	STMMH202	CONDUIT	35.5	
1.0127	0.0100					
C10		J17	J20	CONDUIT	13.5	
0.1114	0.0130					
C11		Ex-CB3	J20	CONDUIT	16.5	
0.3636	0.0130					
C12		CB202	J2	CONDUIT	10.8	
9.2992	0.0100					
C12_1		J20	J1	CONDUIT	6.1	
0.1149	0.0100					
C12_3		J1	J2	CONDUIT	20.0	
0.0150	0.0100					
C12_4		J2	J6	CONDUIT	9.5	
0.3173	0.0100					
C13		ExCBMH3	ExMH103	CONDUIT	43.7	
0.3433	0.0100					
C13_2		STMMH202	Ex-STMH9	CONDUIT	25.1	
0.6767	0.0130					
C13_6		OGS-STMH201	STMMH202	CONDUIT	1.6	
1.2588	0.0130					
C14		Ex-STMH9	EX-STM-MH	CONDUIT	51.7	
0.4836	0.0130					
C15		EX-STM-MH	OF1	CONDUIT	30.2	
5.4063	0.0130					
C17		DI01	ExCB2	CONDUIT	4.0	
1.0001	0.0130					

C18		ExCB2	ExSTMH	CONDUIT	20.9
1.0048	0.0130				
C19		ExSTMH	ExCB	CONDUIT	42.6
0.6337	0.0130				
C2		STM01	STMMH203	CONDUIT	18.4
1.9569	0.0130				
C20		ExCB	J25	CONDUIT	15.4
1.1556	0.0130				
C21		J25	J26	CONDUIT	68.3
0.1304	0.0130				
C22		J26	Ex-STMH9	CONDUIT	18.0
0.8152	0.0130				-
C23		ExCB6	J25	CONDUIT	3.2
9.0367	0.0130				
C24		ExCB8	J26	CONDUIT	4.6
6.9077	0.0130				
C3		SU13_pr	ExCB4	CONDUIT	1.5
121.7448	0.0100				
C4		CB201	J1	CONDUIT	10.7
7.5046	0.0100				
C4_2		CB203	ExCBMH3	CONDUIT	19.4
0.5155	0.0100				
C5		J6	ExMH103	CONDUIT	25.9
0.0773	0.0130				
C6		Ex-CBMH2	J6	CONDUIT	16.5
0.3636	0.0130				
C7		Ex-STMH1	J17	CONDUIT	2.6
11.1583	0.0130				
C8		Ex-CB1	Ex-CBMH1	CONDUIT	58.4
0.4452	0.0130				
C9		Ex-CBMH1	J17	CONDUIT	22.5
1.7558	0.0130				
OR1		SU1	ExCB	CONDUIT	2.0
100.0052	0.0100				
OR10		SU10	ExCBMH3	CONDUIT	1.5
138.1323	0.0100				
OR11		SU11_pr	CB201	CONDUIT	1.5
126.1620	0.0100				
OR12		SU12_pr	CB202	CONDUIT	1.5
114.4781	0.0100				
OR2		SU2	Ex-CB3	CONDUIT	1.7
118.2984	0.0100				
OR3		SU3	Ex-CBMH2	CONDUIT	1.7
121.5502	0.0100				
OR4		SU4	Ex-CBMH1	CONDUIT	1.9
118.3801	0.0100				
OR5		SU5	Ex-CB1	CONDUIT	3.3
73.8777	0.0100				
OR6		SU6	DI01	CONDUIT	2.9
38.3256	0.0100				
OR7		SU7	ExCB8	CONDUIT	2.0
188.3495	0.0100				
OR8		SU8	ExCB6	CONDUIT	1.4
121.7519	0.0100				
C13_5		ExMH103	OGS-STMH201	ORIFICE	
C16		Roof-Storage	STM01	ORIFICE	

Cross Section Summary

Full Conduit Flow	Shape	Full Depth	Full Area	Hyd. Rad.	Max. Width	No. of Barrels
C1	CIRCULAR	0.25	0.05	0.06	0.25	1
0.05						
C1_2	CIRCULAR	0.25	0.05	0.06	0.25	1
0.08						
C10	CIRCULAR	1.50	1.77	0.38	1.50	1
2.36						
C11	CIRCULAR	0.30	0.07	0.07	0.30	1
0.06						
C12	CIRCULAR	0.25	0.05	0.06	0.25	1
0.24						
C12_1	CIRCULAR	1.50	1.77	0.38	1.50	1
3.12						
C12_3	CIRCULAR	1.50	1.77	0.38	1.50	1
1.12						
C12_4	CIRCULAR	1.50	1.77	0.38	1.50	1
5.18						
C13	CIRCULAR	0.30	0.07	0.07	0.30	1
0.07						
C13_2	CIRCULAR	0.38	0.11	0.09	0.38	1
0.14						
C13_6	CIRCULAR	0.38	0.11	0.09	0.38	1
0.20						
C14	CIRCULAR	0.38	0.11	0.09	0.38	1
0.12						
C15	CIRCULAR	0.30	0.07	0.07	0.30	1
0.22						
C17	CIRCULAR	0.20	0.03	0.05	0.20	1
0.03						
C18	CIRCULAR	0.20	0.03	0.05	0.20	1
0.03						
C19	CIRCULAR	0.30	0.07	0.07	0.30	1
0.08						
C2	CIRCULAR	0.25	0.05	0.06	0.25	1
0.08						
C20	CIRCULAR	0.30	0.07	0.07	0.30	1
0.10						
C21	CIRCULAR	0.30	0.07	0.07	0.30	1
0.03						
C22	CIRCULAR	0.30	0.07	0.07	0.30	1
0.09						
C23	CIRCULAR	0.20	0.03	0.05	0.20	1
0.10						
C24	CIRCULAR	0.20	0.03	0.05	0.20	1
0.09						
C3	CIRCULAR	0.25	0.05	0.06	0.25	1
0.85						
C4	CIRCULAR	0.25	0.05	0.06	0.25	1
0.21						
C4_2	CIRCULAR	0.25	0.05	0.06	0.25	1
0.06						
C5	CIRCULAR	1.50	1.77	0.38	1.50	1
1.97						
C6	CIRCULAR	0.30	0.07	0.07	0.30	1

C7	CIRCULAR	1.50	1.77	0.38	1.50	1
23.62						
C8	CIRCULAR	0.25	0.05	0.06	0.25	1
0.04						
C9	CIRCULAR	0.30	0.07	0.07	0.30	1
0.13						
OR1	CIRCULAR	0.25	0.05	0.06	0.25	1
0.77						
OR10	CIRCULAR	0.25	0.05	0.06	0.25	1
0.91						
OR11	CIRCULAR	0.25	0.05	0.06	0.25	1
0.87						
OR12	CIRCULAR	0.25	0.05	0.06	0.25	1
0.83						
OR2	CIRCULAR	0.25	0.05	0.06	0.25	1
0.84						
OR3	CIRCULAR	0.25	0.05	0.06	0.25	1
0.85						
OR4	CIRCULAR	0.25	0.05	0.06	0.25	1
0.84						
OR5	CIRCULAR	0.25	0.05	0.06	0.25	1
0.66						
OR6	CIRCULAR	0.25	0.05	0.06	0.25	1
0.48						
OR7	CIRCULAR	0.25	0.05	0.06	0.25	1
1.06						
OR8	CIRCULAR	0.25	0.05	0.06	0.25	1
0.85						

Analysis Options

Flow Units CMS
Process Models:
 Rainfall/Runoff YES
 RDII NO
 Snowmelt NO
 Groundwater NO
 Flow Routing YES
 Ponding Allowed NO
 Water Quality NO
Infiltration Method HORTON
Flow Routing Method DYNWAVE
Surcharge Method EXTRAN
Starting Date 06/11/2024 00:00:00
Ending Date 06/12/2024 00:00:00
Antecedent Dry Days 0.0
Report Time Step 00:01:00
Wet Time Step 00:05:00
Dry Time Step 00:05:00
Routing Time Step 5.00 sec
Variable Time Step YES
Maximum Trials 8
Number of Threads 8
Head Tolerance 0.001524 m

```

*****
Runoff Quantity Continuity      Volume      Depth
                                hectare-m    mm
*****
Total Precipitation .....      0.103      42.540
Evaporation Loss .....          0.000      0.000
Infiltration Loss .....         0.043      17.811
Surface Runoff .....            0.060      24.552
Final Storage .....            0.000      0.113
Continuity Error (%) .....      0.150

```

```

*****
Flow Routing Continuity      Volume      Volume
                                hectare-m    10^6 ltr
*****
Dry Weather Inflow .....       0.000      0.000
Wet Weather Inflow .....       0.060      0.597
Groundwater Inflow .....       0.000      0.000
RDII Inflow .....             0.000      0.000
External Inflow .....          0.000      0.000
External Outflow .....         0.027      0.272
Flooding Loss .....            0.000      0.000
Evaporation Loss .....          0.000      0.000
Exfiltration Loss .....         0.000      0.000
Initial Stored Volume ....      0.000      0.001
Final Stored Volume .....       0.033      0.326
Continuity Error (%) .....     -0.006

```

```

*****
Highest Continuity Errors
*****
Node J26 (19.30%)
Node J25 (8.12%)

```

```

*****
Time-Step Critical Elements
*****
Link C13_6 (41.92%)
Link OR12 (39.36%)
Link C3 (5.00%)

```

```

*****
Highest Flow Instability Indexes
*****
Link C12_4 (2)

```

```

*****
Most Frequent Nonconverging Nodes
*****
Convergence obtained at all time steps.

```

```

*****
Routing Time Step Summary

```

```

*****
Minimum Time Step      :      0.50 sec
Average Time Step     :      2.02 sec
Maximum Time Step     :      5.00 sec
% of Time in Steady State :      0.00
Average Iterations per Step :      2.00
% of Steps Not Converging :      0.00
Time Step Frequencies :
    5.000 - 3.155 sec :      29.09 %
    3.155 - 1.991 sec :      2.26 %
    1.991 - 1.256 sec :      19.45 %
    1.256 - 0.792 sec :      13.78 %
    0.792 - 0.500 sec :      35.42 %

```

```

*****
Subcatchment Runoff Summary
*****

```

Perv	Total	Total	Total	Total	Total	Total	Imperv
Runoff	Runoff	Runoff	Precip	Peak	Runoff	Evap	Infil
Subcatchment	Runoff	Runoff	Runoff	Runoff	Runoff	Runoff	Runoff
mm	mm	10^6 ltr	mm	mm	mm	mm	mm

			CMS	Coeff			
A1			42.54	0.00	0.00	33.36	5.60
3.68	5.60	0.01	0.01	0.132			
A2_1			42.54	0.00	0.00	37.56	0.42
4.68	5.10	0.00	0.00	0.120			
A2_2			42.54	0.00	0.00	36.77	0.42
5.55	5.97	0.00	0.00	0.140			
A2_3			42.54	0.00	0.00	23.88	15.49
3.06	18.55	0.02	0.01	0.436			
A2_4			42.54	0.00	0.00	37.25	0.42
5.01	5.43	0.00	0.00	0.128			
A2_5			42.54	0.00	0.00	36.47	0.42
5.88	6.30	0.00	0.00	0.148			
A-3Ex			42.54	0.00	0.00	29.21	10.38
2.75	13.13	0.03	0.02	0.309			
A-4EX			42.54	0.00	0.00	29.41	10.39
2.55	12.93	0.05	0.03	0.304			
A5-1			42.54	0.00	0.00	1.20	41.29
0.27	41.56	0.05	0.03	0.977			
A5-2			42.54	0.00	0.00	0.00	42.73
0.00	42.73	0.04	0.03	1.005			
A5-3			42.54	0.00	0.00	6.15	35.50
1.14	36.64	0.08	0.05	0.861			
A5-4			42.54	0.00	0.00	4.77	37.03
0.97	38.00	0.04	0.03	0.893			
A5-5			42.54	0.00	0.00	9.01	32.02
1.72	33.74	0.03	0.02	0.793			
A5-6			42.54	0.00	0.00	0.00	42.73
0.00	42.73	0.04	0.02	1.005			
A5-7			42.54	0.00	0.00	18.08	22.00
2.63	24.63	0.04	0.03	0.579			

A5-8		42.54	0.00	0.00	24.87	14.34
3.47	17.81	0.02	0.01	0.419		
A5-9		42.54	0.00	0.00	13.03	27.64
1.88	29.52	0.09	0.05	0.694		
A5-B-Roof		42.54	0.00	0.00	0.00	42.76
0.00	42.76	0.06	0.04	1.005		

Node Depth Summary

Node	Type	Average Depth Meters	Maximum Depth Meters	Maximum HGL Meters	Time of Max Occurrence days hr:min	Reported Max Depth Meters
CB201	JUNCTION	0.00	0.00	78.30	0 00:00	0.00
CB202	JUNCTION	0.01	0.05	78.55	0 01:10	0.05
CB203	JUNCTION	0.01	0.09	79.07	0 01:10	0.09
DI01	JUNCTION	0.00	0.04	78.24	0 01:20	0.04
ExCB	JUNCTION	0.00	0.03	77.62	0 01:21	0.03
Ex-CB1	JUNCTION	0.00	0.00	78.21	0 00:00	0.00
ExCB2	JUNCTION	0.00	0.03	78.13	0 01:21	0.03
Ex-CB3	JUNCTION	0.00	0.00	78.17	0 00:00	0.00
ExCB4	JUNCTION	0.02	0.11	78.44	0 01:21	0.11
ExCB6	JUNCTION	0.00	0.01	77.71	0 01:20	0.01
ExCB8	JUNCTION	0.00	0.02	77.66	0 01:20	0.02
Ex-CBMH1	JUNCTION	0.06	0.23	78.15	0 02:12	0.23
Ex-CBMH2	JUNCTION	0.02	0.14	78.27	0 01:21	0.14
ExCBMH3	JUNCTION	0.01	0.09	78.91	0 01:10	0.09
ExMH103	JUNCTION	0.35	0.74	78.15	0 02:12	0.74
ExSTMH	JUNCTION	0.00	0.03	77.89	0 01:21	0.03
Ex-STMH1	JUNCTION	0.11	0.34	78.15	0 02:10	0.34
Ex-STMH9	JUNCTION	0.04	0.10	77.28	0 01:28	0.10
EX-STM-MH	JUNCTION	0.03	0.06	76.69	0 01:10	0.06
J1	JUNCTION	0.29	0.64	78.15	0 02:10	0.64
J17	JUNCTION	0.27	0.62	78.15	0 02:10	0.62
J2	JUNCTION	0.29	0.65	78.15	0 02:11	0.65
J20	JUNCTION	0.28	0.64	78.15	0 02:11	0.64
J25	JUNCTION	0.06	0.11	77.52	0 01:26	0.11
J26	JUNCTION	0.14	0.20	77.52	0 01:25	0.20
J6	JUNCTION	0.31	0.68	78.15	0 02:09	0.68
OGS-STMH201	JUNCTION	0.05	0.09	77.48	0 01:34	0.09
STM01	JUNCTION	0.02	0.06	78.29	0 01:28	0.06
STMMH202	JUNCTION	0.07	0.11	77.48	0 01:34	0.11
STMMH203	JUNCTION	0.02	0.06	77.87	0 01:28	0.06
OF1	OUTFALL	0.30	0.30	75.30	0 00:00	0.30
OF2	OUTFALL	0.00	0.00	0.00	0 00:00	0.00
OF3	OUTFALL	0.00	0.00	0.00	0 00:00	0.00
OF4	OUTFALL	0.00	0.00	0.00	0 00:00	0.00
Roof-Storage	STORAGE	0.03	0.09	88.32	0 01:27	0.09
SU1	STORAGE	0.00	0.01	79.03	0 01:10	0.01
SU10	STORAGE	0.20	0.22	80.82	1 00:00	0.22
SU11_pr	STORAGE	0.19	0.21	80.11	1 00:00	0.21
SU12_pr	STORAGE	0.10	0.13	80.23	0 01:10	0.13
SU13_pr	STORAGE	0.24	0.28	80.23	0 01:20	0.28

SU2	STORAGE	0.17	0.19	80.04	1	00:00	0.19
SU3	STORAGE	0.19	0.20	80.06	1	00:00	0.20
SU4	STORAGE	0.21	0.23	80.10	1	00:00	0.23
SU5	STORAGE	0.21	0.22	80.15	1	00:00	0.22
SU6	STORAGE	0.00	0.01	79.26	0	01:20	0.01
SU7	STORAGE	0.00	0.01	79.42	0	01:20	0.01
SU8	STORAGE	0.00	0.01	78.82	0	01:20	0.01

Node Inflow Summary

Total Inflow Volume Node ltr	Flow Balance Error Percent	Type	Maximum Lateral Inflow CMS	Maximum Total Inflow CMS	Time of Max Occurrence days hr:min	Lateral Inflow Volume 10^6 ltr
0	0.000	JUNCTION	0.000	0.000	0 00:00	0
0.0348	-0.004	JUNCTION	0.000	0.024	0 01:10	0
0.0185	-0.000	JUNCTION	0.012	0.012	0 01:10	0.0185
0.00305	0.031	JUNCTION	0.000	0.002	0 01:20	0
0.00382	-0.246	JUNCTION	0.000	0.002	0 01:21	0
0	0.000	JUNCTION	0.000	0.000	0 00:00	0
0.00305	0.027	JUNCTION	0.000	0.002	0 01:20	0
0	0.000	JUNCTION	0.000	0.000	0 00:00	0
0.0402	-0.007	JUNCTION	0.000	0.020	0 01:20	0
0.00116	0.005	JUNCTION	0.000	0.001	0 01:20	0
0.00234	0.006	JUNCTION	0.000	0.002	0 01:20	0
0.00188	0.010	JUNCTION	0.000	0.002	0 01:23	0
0.0402	0.163	JUNCTION	0.000	0.020	0 01:21	0
0.0185	-0.002	JUNCTION	0.000	0.011	0 01:10	0
0.0949	-0.015	JUNCTION	0.000	0.011	0 01:10	0
0.00305	0.015	JUNCTION	0.000	0.002	0 01:21	0
0.000537	0.006	JUNCTION	0.000	0.001	0 01:14	0

Ex-STMH9		JUNCTION	0.000	0.016	0	01:28	0
0.159	-0.019						
EX-STM-MH		JUNCTION	0.015	0.023	0	01:10	0.024
0.183	0.000						
J1		JUNCTION	0.000	0.016	0	01:21	0
0.0432	0.045						
J17		JUNCTION	0.000	0.007	0	01:23	0
0.012	0.058						
J2		JUNCTION	0.000	0.024	0	01:10	0
0.0739	-0.028						
J20		JUNCTION	0.000	0.011	0	01:21	0
0.0261	-0.011						
J25		JUNCTION	0.000	0.003	0	01:20	0
0.00536	8.833						
J26		JUNCTION	0.000	0.004	0	01:20	0
0.0074	23.914						
J6		JUNCTION	0.000	0.020	0	01:21	0
0.0887	-0.037						
OGS-STMH201		JUNCTION	0.000	0.005	0	02:15	0
0.0938	0.010						
STM01		JUNCTION	0.000	0.008	0	01:27	0
0.0603	-0.000						
STMMH202		JUNCTION	0.000	0.013	0	01:34	0
0.154	0.026						
STMMH203		JUNCTION	0.000	0.008	0	01:28	0
0.0603	0.002						
OF1		OUTFALL	0.000	0.023	0	01:10	0
0.183	0.000						
OF2		OUTFALL	0.005	0.005	0	01:05	0.00851
0.00851	0.000						
OF3		OUTFALL	0.027	0.027	0	01:10	0.0456
0.0456	0.000						
OF4		OUTFALL	0.021	0.021	0	01:10	0.0349
0.0349	0.000						
Roof-Storage		STORAGE	0.038	0.038	0	01:10	0.0603
0.0603	-0.000						
SU1		STORAGE	0.001	0.001	0	01:10	0.000774
0.000774	-0.014						
SU10		STORAGE	0.054	0.054	0	01:10	0.0862
0.0862	0.011						
SU11_pr		STORAGE	0.017	0.017	0	01:10	0.026
0.026	0.011						
SU12_pr		STORAGE	0.024	0.024	0	01:10	0.0385
0.0385	0.001						
SU13_pr		STORAGE	0.050	0.050	0	01:10	0.0779
0.0779	0.005						
SU2		STORAGE	0.031	0.031	0	01:10	0.049
0.049	0.011						
SU3		STORAGE	0.025	0.025	0	01:10	0.0402
0.0402	0.011						
SU4		STORAGE	0.026	0.026	0	01:10	0.0399
0.0399	0.011						
SU5		STORAGE	0.025	0.025	0	01:10	0.0401
0.0401	0.011						
SU6		STORAGE	0.002	0.002	0	01:20	0.00305
0.00305	-0.003						
SU7		STORAGE	0.002	0.002	0	01:20	0.00234
0.00234	-0.005						
SU8		STORAGE	0.001	0.001	0	01:20	0.00116
0.00116	-0.002						

Node Surcharge Summary

No nodes were surcharged.

Node Flooding Summary

No nodes were flooded.

Storage Volume Summary

Max Occurrence	Maximum Storage Unit	Average Volume	Avg Pcmt Full	Evap Loss	Exfil Loss	Maximum Volume	Max Pcmt Full	Time of days
hr:min	Outflow CMS	1000 m ³				1000 m ³		
01:27	Roof-Storage 0.008	0.008	8.6	0.0	0.0	0.033	34.5	0
01:10	SU1 0.001	0.000	0.0	0.0	0.0	0.000	0.0	0
00:00	SU10 0.000	0.077	0.2	0.0	0.0	0.086	0.2	1
00:00	SU11_pr 0.000	0.023	0.2	0.0	0.0	0.026	0.2	1
01:10	SU12_pr 0.024	0.004	0.0	0.0	0.0	0.006	0.1	0
01:20	SU13_pr 0.020	0.037	0.2	0.0	0.0	0.046	0.3	0
00:00	SU2 0.000	0.044	0.1	0.0	0.0	0.049	0.1	1
00:00	SU3 0.000	0.036	0.1	0.0	0.0	0.040	0.2	1
00:00	SU4 0.000	0.036	0.2	0.0	0.0	0.040	0.2	1
00:00	SU5 0.000	0.036	0.2	0.0	0.0	0.040	0.2	1
01:20	SU6 0.002	0.000	0.0	0.0	0.0	0.000	0.0	0
01:20	SU7 0.002	0.000	0.0	0.0	0.0	0.000	0.0	0
01:20	SU8 0.001	0.000	0.0	0.0	0.0	0.000	0.0	0

Outfall Loading Summary

Outfall Node	Flow Freq Pcnt	Avg Flow CMS	Max Flow CMS	Total Volume 10^6 ltr
OF1	71.16	0.009	0.023	0.183
OF2	37.86	0.001	0.005	0.009
OF3	40.90	0.005	0.027	0.046
OF4	40.13	0.004	0.021	0.035
System	47.51	0.018	0.076	0.272

Link Flow Summary

Link	Type	Maximum Flow CMS	Time of Max Occurrence days hr:min	Maximum Veloc m/sec	Max/ Full Flow	Max/ Full Depth
C1	CONDUIT	0.020	0 01:21	0.99	0.39	0.43
C1_2	CONDUIT	0.008	0 01:28	1.00	0.11	0.23
C10	CONDUIT	0.007	0 01:23	0.14	0.00	0.42
C11	CONDUIT	0.000	0 00:00	0.00	0.00	0.06
C12	CONDUIT	0.024	0 01:10	1.74	0.10	0.61
C12_1	CONDUIT	0.011	0 01:21	0.15	0.00	0.43
C12_3	CONDUIT	0.016	0 01:21	0.20	0.01	0.43
C12_4	CONDUIT	0.014	0 01:23	0.28	0.00	0.44
C13	CONDUIT	0.011	0 01:10	0.69	0.15	0.28
C13_2	CONDUIT	0.013	0 01:34	0.77	0.09	0.21
C13_6	CONDUIT	0.005	0 02:15	0.29	0.02	0.27
C14	CONDUIT	0.016	0 01:28	0.75	0.13	0.25
C15	CONDUIT	0.023	0 01:10	0.51	0.10	0.61
C17	CONDUIT	0.002	0 01:20	0.53	0.06	0.17
C18	CONDUIT	0.002	0 01:21	0.56	0.06	0.16
C19	CONDUIT	0.002	0 01:21	0.46	0.02	0.11
C2	CONDUIT	0.008	0 01:28	1.05	0.10	0.22
C20	CONDUIT	0.002	0 01:21	0.38	0.02	0.23
C21	CONDUIT	0.003	0 01:23	0.16	0.08	0.51
C22	CONDUIT	0.004	0 01:25	0.14	0.04	0.40
C23	CONDUIT	0.001	0 01:20	0.47	0.01	0.30
C24	CONDUIT	0.002	0 01:20	0.40	0.02	0.54
C3	CONDUIT	0.020	0 01:20	2.52	0.02	0.27
C4	CONDUIT	0.000	0 00:00	0.00	0.00	0.50
C4_2	CONDUIT	0.011	0 01:10	0.82	0.21	0.33
C5	CONDUIT	0.005	0 01:56	0.09	0.00	0.46
C6	CONDUIT	0.020	0 01:21	0.74	0.35	0.41
C7	CONDUIT	0.001	0 01:14	0.01	0.00	0.32
C8	CONDUIT	0.000	0 00:00	0.00	0.00	0.39
C9	CONDUIT	0.002	0 01:23	0.05	0.02	0.88
OR1	CONDUIT	0.001	0 01:10	0.65	0.00	0.07
OR10	CONDUIT	0.000	0 00:00	0.00	0.00	0.18

OR11	CONDUIT	0.000	0	00:00	0.00	0.00	0.00
OR12	CONDUIT	0.024	0	01:10	4.47	0.03	0.17
OR2	CONDUIT	0.000	0	00:00	0.00	0.00	0.00
OR3	CONDUIT	0.000	0	00:00	0.00	0.00	0.28
OR4	CONDUIT	0.000	0	00:00	0.00	0.00	0.45
OR5	CONDUIT	0.000	0	00:00	0.00	0.00	0.00
OR6	CONDUIT	0.002	0	01:20	0.79	0.00	0.10
OR7	CONDUIT	0.002	0	01:20	1.60	0.00	0.05
OR8	CONDUIT	0.001	0	01:20	1.36	0.00	0.04
C13_5	ORIFICE	0.005	0	02:15			1.00
C16	ORIFICE	0.008	0	01:27			0.44

Flow Classification Summary

Inlet Conduit Ctrl	Adjusted /Actual Length	----- Fraction of Time in Flow Class -----							
		Up Dry	Down Dry	Sub Dry	Sup Crit	Up Crit	Down Crit	Norm Ltd	
C1 0.00	1.00	0.05	0.00	0.00	0.00	0.00	0.00	0.95	0.00
C1_2 0.00	1.00	0.01	0.00	0.00	0.00	0.00	0.00	0.99	0.00
C10 0.00	1.00	0.70	0.00	0.00	0.29	0.00	0.00	0.00	0.67
C11 0.00	1.00	0.95	0.05	0.00	0.00	0.00	0.00	0.00	0.00
C12 0.00	1.00	0.69	0.10	0.00	0.20	0.01	0.00	0.00	0.96
C12_1 0.00	1.00	0.04	0.66	0.00	0.30	0.00	0.00	0.00	0.67
C12_3 0.00	1.00	0.04	0.00	0.00	0.96	0.00	0.00	0.00	0.00
C12_4 0.00	1.00	0.04	0.65	0.00	0.31	0.00	0.00	0.00	0.67
C13 0.00	1.00	0.01	0.00	0.00	0.00	0.00	0.00	0.99	0.00
C13_2 0.00	1.00	0.02	0.00	0.00	0.00	0.00	0.00	0.98	0.00
C13_6 0.00	1.00	0.01	0.00	0.00	0.99	0.00	0.00	0.00	0.00
C14 0.00	1.00	0.04	0.00	0.00	0.00	0.00	0.00	0.96	0.00
C15 0.00	1.00	0.00	0.01	0.00	0.99	0.00	0.00	0.00	0.99
C17 0.00	1.00	0.01	0.00	0.00	0.00	0.00	0.00	0.99	0.00
C18 0.00	1.00	0.02	0.00	0.00	0.00	0.00	0.00	0.98	0.00
C19 0.00	1.00	0.02	0.00	0.00	0.98	0.00	0.00	0.00	0.87

Conduit	Both Ends	Upstream	Dnstream	Normal Flow	Limited
C12	0.01	0.01	22.82	0.01	0.01
C15	0.01	0.01	23.83	0.01	0.01
C9	0.01	0.01	22.66	0.01	0.01

Analysis begun on: Mon Jun 24 16:06:14 2024

Analysis ended on: Mon Jun 24 16:06:15 2024

Total elapsed time: 00:00:01

EPA STORM WATER MANAGEMENT MODEL - VERSION 5.2 (Build 5.2.4)

WARNING 03: negative offset ignored for Link C2
 WARNING 08: elevation drop exceeds length for Conduit C3
 WARNING 03: negative offset ignored for Link OR1
 WARNING 08: elevation drop exceeds length for Conduit OR10
 WARNING 08: elevation drop exceeds length for Conduit OR11
 WARNING 08: elevation drop exceeds length for Conduit OR12
 WARNING 08: elevation drop exceeds length for Conduit OR2
 WARNING 08: elevation drop exceeds length for Conduit OR3
 WARNING 08: elevation drop exceeds length for Conduit OR4
 WARNING 03: negative offset ignored for Link OR6
 WARNING 03: negative offset ignored for Link OR7
 WARNING 03: negative offset ignored for Link OR8

Element Count

Number of rain gages 3
 Number of subcatchments ... 18
 Number of nodes 47
 Number of links 43
 Number of pollutants 0
 Number of land uses 0

Raingage Summary

Name	Data Source	Data Type	Recording Interval
Riverside_100year	Chicago_3h_100yr_10min	INTENSITY	10 min.
Riverside_100yr+20%	Chicago_3hr_100yr+20%_10min	INTENSITY	10 min.
Riverside_5Year	Chicago_3h_5yr_10min	INTENSITY	10 min.

Subcatchment Summary

Name	Area	Width	%Imperv	%Slope	Rain Gage
Outlet					
A1	0.15	55.19	13.15	0.7360	Riverside_100year
OF2					
A2_1	0.06	35.18	1.00	0.6420	Riverside_100year
SU6					
A2_2	0.02	19.50	1.00	0.6420	Riverside_100year
SU8					
A2_3	0.13	51.68	36.87	0.6420	Riverside_100year
EX-STM-MH					
A2_4	0.04	30.79	1.00	0.6420	Riverside_100year
SU7					
A2_5	0.01	15.38	1.00	0.6420	Riverside_100year
SU1					

A-3Ex OF4	0.27	73.89	25.00	0.5000	Riverside_100year
A-4EX OF3	0.35	84.05	25.00	0.5000	Riverside_100year
A5-1 SU2	0.12	48.62	96.60	1.0000	Riverside_100year
A5-2 SU3	0.09	44.76	100.00	1.0000	Riverside_100year
A5-3 SU13_pr	0.21	66.44	83.01	1.0000	Riverside_100year
A5-4 SU4	0.10	45.65	86.67	1.0000	Riverside_100year
A5-5 SU11_pr	0.08	40.53	75.03	1.0000	Riverside_100year
A5-6 SU12_pr	0.09	42.86	100.00	1.0000	Riverside_100year
A5-7 SU5	0.16	58.21	51.53	0.9600	Riverside_100year
A5-8 CB203	0.10	45.22	33.65	0.9620	Riverside_100year
A5-9 SU10	0.29	76.84	65.09	0.8680	Riverside_100year
A5-B-Roof Roof-Storage	0.14	54.23	100.00	1.0000	Riverside_100year

Node Summary

Name	Type	Invert Elev.	Max. Depth	Ponded Area	External Inflow
CB201	JUNCTION	78.30	1.60	0.0	
CB202	JUNCTION	78.50	1.60	0.0	
CB203	JUNCTION	78.98	1.97	0.0	
DI01	JUNCTION	78.20	1.05	0.0	
ExCB	JUNCTION	77.59	1.44	0.0	
Ex-CB1	JUNCTION	78.21	1.72	0.0	
ExCB2	JUNCTION	78.10	0.73	0.0	
Ex-CB3	JUNCTION	78.17	1.68	0.0	
ExCB4	JUNCTION	78.33	1.62	0.0	
ExCB6	JUNCTION	77.70	1.13	0.0	
ExCB8	JUNCTION	77.64	1.77	0.0	
Ex-CBMH1	JUNCTION	77.92	1.95	0.0	
Ex-CBMH2	JUNCTION	78.13	1.73	0.0	
ExCBMH3	JUNCTION	78.82	1.78	0.0	
ExMH103	JUNCTION	77.41	3.00	0.0	
ExSTMH	JUNCTION	77.86	2.26	0.0	
Ex-STMH1	JUNCTION	77.81	2.34	0.0	
Ex-STMH9	JUNCTION	77.18	3.24	0.0	
EX-STM-MH	JUNCTION	76.63	2.93	0.0	
J1	JUNCTION	77.50	2.68	0.0	
J17	JUNCTION	77.53	2.62	0.0	
J2	JUNCTION	77.50	2.80	0.0	
J20	JUNCTION	77.51	2.64	0.0	
J25	JUNCTION	77.41	1.43	0.0	
J26	JUNCTION	77.32	2.10	0.0	
J6	JUNCTION	77.47	2.89	0.0	

OGS-STMH201	JUNCTION	77.39	3.06	0.0
STM01	JUNCTION	78.23	5.00	0.0
STMMH202	JUNCTION	77.37	3.00	0.0
STMMH203	JUNCTION	77.81	3.12	0.0
OF1	OUTFALL	75.00	0.30	0.0
OF2	OUTFALL	0.00	0.00	0.0
OF3	OUTFALL	0.00	0.00	0.0
OF4	OUTFALL	0.00	0.00	0.0
Roof-Storage	STORAGE	88.23	0.15	0.0
SU1	STORAGE	79.03	5.00	0.0
SU10	STORAGE	80.60	5.00	0.0
SU11_pr	STORAGE	79.90	5.00	0.0
SU12_pr	STORAGE	80.10	5.00	0.0
SU13_pr	STORAGE	79.95	5.00	0.0
SU2	STORAGE	79.85	5.00	0.0
SU3	STORAGE	79.86	5.00	0.0
SU4	STORAGE	79.87	5.00	0.0
SU5	STORAGE	79.93	5.00	0.0
SU6	STORAGE	79.25	5.00	0.0
SU7	STORAGE	79.41	5.00	0.0
SU8	STORAGE	78.81	5.00	0.0

Link Summary

Name		From Node	To Node	Type	Length	%
Slope	Roughness					

C1		ExCB4	Ex-CBMH2	CONDUIT	31.4	
0.4459	0.0100					
C1_2		STMMH203	STMMH202	CONDUIT	35.5	
1.0127	0.0100					
C10		J17	J20	CONDUIT	13.5	
0.1114	0.0130					
C11		Ex-CB3	J20	CONDUIT	16.5	
0.3636	0.0130					
C12		CB202	J2	CONDUIT	10.8	
9.2992	0.0100					
C12_1		J20	J1	CONDUIT	6.1	
0.1149	0.0100					
C12_3		J1	J2	CONDUIT	20.0	
0.0150	0.0100					
C12_4		J2	J6	CONDUIT	9.5	
0.3173	0.0100					
C13		ExCBMH3	ExMH103	CONDUIT	43.7	
0.3433	0.0100					
C13_2		STMMH202	Ex-STMH9	CONDUIT	25.1	
0.6767	0.0130					
C13_6		OGS-STMH201	STMMH202	CONDUIT	1.6	
1.2588	0.0130					
C14		Ex-STMH9	EX-STM-MH	CONDUIT	51.7	
0.4836	0.0130					
C15		EX-STM-MH	OF1	CONDUIT	30.2	
5.4063	0.0130					
C17		DI01	ExCB2	CONDUIT	4.0	
1.0001	0.0130					

C18		ExCB2	ExSTMH	CONDUIT	20.9
1.0048	0.0130				
C19		ExSTMH	ExCB	CONDUIT	42.6
0.6337	0.0130				
C2		STM01	STMMH203	CONDUIT	18.4
1.9569	0.0130				
C20		ExCB	J25	CONDUIT	15.4
1.1556	0.0130				
C21		J25	J26	CONDUIT	68.3
0.1304	0.0130				
C22		J26	Ex-STMH9	CONDUIT	18.0
0.8152	0.0130				-
C23		ExCB6	J25	CONDUIT	3.2
9.0367	0.0130				
C24		ExCB8	J26	CONDUIT	4.6
6.9077	0.0130				
C3		SU13_pr	ExCB4	CONDUIT	1.5
121.7448	0.0100				
C4		CB201	J1	CONDUIT	10.7
7.5046	0.0100				
C4_2		CB203	ExCBMH3	CONDUIT	19.4
0.5155	0.0100				
C5		J6	ExMH103	CONDUIT	25.9
0.0773	0.0130				
C6		Ex-CBMH2	J6	CONDUIT	16.5
0.3636	0.0130				
C7		Ex-STMH1	J17	CONDUIT	2.6
11.1583	0.0130				
C8		Ex-CB1	Ex-CBMH1	CONDUIT	58.4
0.4452	0.0130				
C9		Ex-CBMH1	J17	CONDUIT	22.5
1.7558	0.0130				
OR1		SU1	ExCB	CONDUIT	2.0
100.0052	0.0100				
OR10		SU10	ExCBMH3	CONDUIT	1.5
138.1323	0.0100				
OR11		SU11_pr	CB201	CONDUIT	1.5
126.1620	0.0100				
OR12		SU12_pr	CB202	CONDUIT	1.5
114.4781	0.0100				
OR2		SU2	Ex-CB3	CONDUIT	1.7
118.2984	0.0100				
OR3		SU3	Ex-CBMH2	CONDUIT	1.7
121.5502	0.0100				
OR4		SU4	Ex-CBMH1	CONDUIT	1.9
118.3801	0.0100				
OR5		SU5	Ex-CB1	CONDUIT	3.3
73.8777	0.0100				
OR6		SU6	DI01	CONDUIT	2.9
38.3256	0.0100				
OR7		SU7	ExCB8	CONDUIT	2.0
188.3495	0.0100				
OR8		SU8	ExCB6	CONDUIT	1.4
121.7519	0.0100				
C13_5		ExMH103	OGS-STMH201	ORIFICE	
C16		Roof-Storage	STM01	ORIFICE	

Cross Section Summary

Full Conduit Flow	Shape	Full Depth	Full Area	Hyd. Rad.	Max. Width	No. of Barrels
C1	CIRCULAR	0.25	0.05	0.06	0.25	1
0.05						
C1_2	CIRCULAR	0.25	0.05	0.06	0.25	1
0.08						
C10	CIRCULAR	1.50	1.77	0.38	1.50	1
2.36						
C11	CIRCULAR	0.30	0.07	0.07	0.30	1
0.06						
C12	CIRCULAR	0.25	0.05	0.06	0.25	1
0.24						
C12_1	CIRCULAR	1.50	1.77	0.38	1.50	1
3.12						
C12_3	CIRCULAR	1.50	1.77	0.38	1.50	1
1.12						
C12_4	CIRCULAR	1.50	1.77	0.38	1.50	1
5.18						
C13	CIRCULAR	0.30	0.07	0.07	0.30	1
0.07						
C13_2	CIRCULAR	0.38	0.11	0.09	0.38	1
0.14						
C13_6	CIRCULAR	0.38	0.11	0.09	0.38	1
0.20						
C14	CIRCULAR	0.38	0.11	0.09	0.38	1
0.12						
C15	CIRCULAR	0.30	0.07	0.07	0.30	1
0.22						
C17	CIRCULAR	0.20	0.03	0.05	0.20	1
0.03						
C18	CIRCULAR	0.20	0.03	0.05	0.20	1
0.03						
C19	CIRCULAR	0.30	0.07	0.07	0.30	1
0.08						
C2	CIRCULAR	0.25	0.05	0.06	0.25	1
0.08						
C20	CIRCULAR	0.30	0.07	0.07	0.30	1
0.10						
C21	CIRCULAR	0.30	0.07	0.07	0.30	1
0.03						
C22	CIRCULAR	0.30	0.07	0.07	0.30	1
0.09						
C23	CIRCULAR	0.20	0.03	0.05	0.20	1
0.10						
C24	CIRCULAR	0.20	0.03	0.05	0.20	1
0.09						
C3	CIRCULAR	0.25	0.05	0.06	0.25	1
0.85						
C4	CIRCULAR	0.25	0.05	0.06	0.25	1
0.21						
C4_2	CIRCULAR	0.25	0.05	0.06	0.25	1
0.06						
C5	CIRCULAR	1.50	1.77	0.38	1.50	1
1.97						
C6	CIRCULAR	0.30	0.07	0.07	0.30	1

C7	CIRCULAR	1.50	1.77	0.38	1.50	1
23.62						
C8	CIRCULAR	0.25	0.05	0.06	0.25	1
0.04						
C9	CIRCULAR	0.30	0.07	0.07	0.30	1
0.13						
OR1	CIRCULAR	0.25	0.05	0.06	0.25	1
0.77						
OR10	CIRCULAR	0.25	0.05	0.06	0.25	1
0.91						
OR11	CIRCULAR	0.25	0.05	0.06	0.25	1
0.87						
OR12	CIRCULAR	0.25	0.05	0.06	0.25	1
0.83						
OR2	CIRCULAR	0.25	0.05	0.06	0.25	1
0.84						
OR3	CIRCULAR	0.25	0.05	0.06	0.25	1
0.85						
OR4	CIRCULAR	0.25	0.05	0.06	0.25	1
0.84						
OR5	CIRCULAR	0.25	0.05	0.06	0.25	1
0.66						
OR6	CIRCULAR	0.25	0.05	0.06	0.25	1
0.48						
OR7	CIRCULAR	0.25	0.05	0.06	0.25	1
1.06						
OR8	CIRCULAR	0.25	0.05	0.06	0.25	1
0.85						

Analysis Options

Flow Units CMS
Process Models:
 Rainfall/Runoff YES
 RDII NO
 Snowmelt NO
 Groundwater NO
 Flow Routing YES
 Ponding Allowed NO
 Water Quality NO
Infiltration Method HORTON
Flow Routing Method DYNWAVE
Surcharge Method EXTRAN
Starting Date 06/11/2024 00:00:00
Ending Date 06/12/2024 00:00:00
Antecedent Dry Days 0.0
Report Time Step 00:01:00
Wet Time Step 00:05:00
Dry Time Step 00:05:00
Routing Time Step 5.00 sec
Variable Time Step YES
Maximum Trials 8
Number of Threads 8
Head Tolerance 0.001524 m

```

*****
Runoff Quantity Continuity      Volume      Depth
                                hectare-m    mm
*****
Total Precipitation .....      0.174      71.677
Evaporation Loss .....          0.000      0.000
Infiltration Loss .....         0.053      21.912
Surface Runoff .....            0.119      48.787
Final Storage .....             0.000      0.113
Continuity Error (%) .....       1.207

```

```

*****
Flow Routing Continuity      Volume      Volume
                                hectare-m    10^6 ltr
*****
Dry Weather Inflow .....        0.000      0.000
Wet Weather Inflow .....        0.119      1.186
Groundwater Inflow .....         0.000      0.000
RDII Inflow .....               0.000      0.000
External Inflow .....           0.000      0.000
External Outflow .....          0.067      0.674
Flooding Loss .....             0.000      0.000
Evaporation Loss .....          0.000      0.000
Exfiltration Loss .....         0.000      0.000
Initial Stored Volume ....       0.000      0.001
Final Stored Volume .....        0.054      0.535
Continuity Error (%) .....      -1.811

```

```

*****
Highest Continuity Errors
*****
Node J17 (-21.15%)
Node Ex-CB3 (-5.57%)
Node J26 (3.26%)
Node CB201 (-2.78%)
Node J20 (-1.78%)

```

```

*****
Time-Step Critical Elements
*****
Link C13_6 (64.06%)
Link C3 (13.39%)
Link OR12 (8.75%)

```

```

*****
Highest Flow Instability Indexes
*****
Link C7 (18)
Link C12_1 (9)
Link C10 (9)
Link C12_4 (8)
Link C5 (7)

```

```

*****

```

Most Frequent Nonconverging Nodes

Node OF1 (3.56%)
 Node OF2 (3.56%)
 Node OF3 (3.56%)
 Node OF4 (3.56%)
 Node ExCB4 (2.01%)

Routing Time Step Summary

Minimum Time Step : 0.50 sec
 Average Time Step : 1.60 sec
 Maximum Time Step : 5.00 sec
 % of Time in Steady State : 0.00
 Average Iterations per Step : 2.38
 % of Steps Not Converging : 3.56
 Time Step Frequencies :
 5.000 - 3.155 sec : 13.02 %
 3.155 - 1.991 sec : 1.04 %
 1.991 - 1.256 sec : 15.32 %
 1.256 - 0.792 sec : 58.50 %
 0.792 - 0.500 sec : 12.12 %

Subcatchment Runoff Summary

Perv	Total	Total	Total	Total	Total	Total	Imperv
Runoff	Runoff	Total	Peak	Runoff	Evap	Infil	Runoff
Subcatchment	Runoff	Precip	Runoff	Runon	mm	mm	mm
mm	mm	10^6 ltr	mm	Coeff			

A1		71.68		0.00	0.00	40.94	9.43
21.79	9.43	0.01	0.01	0.132			
A2_1		71.68		0.00	0.00	45.93	0.71
25.71	26.42	0.02	0.01	0.369			
A2_2		71.68		0.00	0.00	44.91	0.71
27.08	27.79	0.01	0.01	0.388			
A2_3		71.68		0.00	0.00	29.19	26.24
16.51	42.75	0.06	0.04	0.596			
A2_4		71.68		0.00	0.00	45.51	0.71
26.24	26.96	0.01	0.01	0.376			
A2_5		71.68		0.00	0.00	44.60	0.71
27.57	28.29	0.00	0.00	0.395			
A-3Ex		71.68		0.00	0.00	36.10	17.67
17.97	35.64	0.09	0.06	0.497			
A-4EX		71.68		0.00	0.00	36.52	17.68
17.50	35.18	0.12	0.07	0.491			
A5-1		71.68		0.00	0.00	1.49	69.58
1.10	70.68	0.08	0.06	0.986			

A5-2		71.68	0.00	0.00	0.00	71.99
0.00	71.99	0.07	0.05	1.004		
A5-3		71.68	0.00	0.00	7.56	59.82
4.94	64.76	0.14	0.10	0.904		
A5-4		71.68	0.00	0.00	5.88	62.38
4.03	66.41	0.07	0.05	0.927		
A5-5		71.68	0.00	0.00	11.08	53.93
7.33	61.26	0.05	0.04	0.855		
A5-6		71.68	0.00	0.00	0.00	71.99
0.00	71.99	0.06	0.04	1.004		
A5-7		71.68	0.00	0.00	22.08	37.05
13.12	50.17	0.08	0.06	0.700		
A5-8		71.68	0.00	0.00	30.36	24.15
17.77	41.93	0.04	0.03	0.585		
A5-9		71.68	0.00	0.00	15.92	46.71
9.43	56.14	0.16	0.12	0.783		
A5-B-Roof		71.68	0.00	0.00	0.00	72.06
0.00	72.06	0.10	0.07	1.005		

Node Depth Summary

Node	Type	Average Depth Meters	Maximum Depth Meters	Maximum HGL Meters	Time of Max Occurrence days hr:min	Reported Max Depth Meters
CB201	JUNCTION	0.27	1.24	79.54	0 02:34	1.24
CB202	JUNCTION	0.19	1.04	79.54	0 02:34	1.04
CB203	JUNCTION	0.07	0.56	79.54	0 02:34	0.56
DI01	JUNCTION	0.01	0.10	78.30	0 01:11	0.10
ExCB	JUNCTION	0.01	0.08	77.67	0 01:13	0.08
Ex-CB1	JUNCTION	0.31	1.33	79.54	0 02:34	1.33
ExCB2	JUNCTION	0.01	0.09	78.19	0 01:11	0.09
Ex-CB3	JUNCTION	0.33	1.37	79.54	0 02:34	1.37
ExCB4	JUNCTION	0.26	1.21	79.54	0 02:34	1.21
ExCB6	JUNCTION	0.00	0.03	77.73	0 01:10	0.03
ExCB8	JUNCTION	0.00	0.04	77.68	0 01:10	0.04
Ex-CBMH1	JUNCTION	0.47	1.62	79.54	0 02:34	1.62
Ex-CBMH2	JUNCTION	0.36	1.41	79.54	0 02:34	1.41
ExCBMH3	JUNCTION	0.11	0.72	79.54	0 02:34	0.72
ExMH103	JUNCTION	0.85	2.13	79.54	0 02:34	2.13
ExSTMH	JUNCTION	0.01	0.08	77.94	0 01:12	0.08
Ex-STMH1	JUNCTION	0.54	1.73	79.54	0 02:34	1.73
Ex-STMH9	JUNCTION	0.06	0.16	77.34	0 01:15	0.16
EX-STM-MH	JUNCTION	0.04	0.11	76.74	0 01:13	0.11
J1	JUNCTION	0.77	2.04	79.54	0 02:34	2.04
J17	JUNCTION	0.76	2.02	79.54	0 02:34	2.02
J2	JUNCTION	0.78	2.04	79.54	0 02:34	2.04
J20	JUNCTION	0.77	2.03	79.54	0 02:34	2.03
J25	JUNCTION	0.07	0.25	77.67	0 01:13	0.25
J26	JUNCTION	0.15	0.32	77.65	0 01:13	0.32
J6	JUNCTION	0.80	2.07	79.54	0 02:34	2.07
OGS-STMH201	JUNCTION	0.06	0.11	77.50	0 01:35	0.11
STM01	JUNCTION	0.02	0.07	78.30	0 01:24	0.07
STMMH202	JUNCTION	0.08	0.13	77.50	0 01:34	0.13

STMMH203	JUNCTION	0.02	0.07	77.88	0	01:25	0.07
OF1	OUTFALL	0.30	0.30	75.30	0	00:00	0.30
OF2	OUTFALL	0.00	0.00	0.00	0	00:00	0.00
OF3	OUTFALL	0.00	0.00	0.00	0	00:00	0.00
OF4	OUTFALL	0.00	0.00	0.00	0	00:00	0.00
Roof-Storage	STORAGE	0.03	0.12	88.35	0	01:24	0.12
SU1	STORAGE	0.00	0.01	79.04	0	01:10	0.01
SU10	STORAGE	0.28	0.30	80.90	1	00:00	0.30
SU11_pr	STORAGE	0.26	0.28	80.18	1	00:00	0.28
SU12_pr	STORAGE	0.10	0.14	80.24	0	01:10	0.14
SU13_pr	STORAGE	0.25	0.30	80.25	0	01:11	0.30
SU2	STORAGE	0.23	0.25	80.10	1	00:00	0.25
SU3	STORAGE	0.24	0.26	80.12	1	00:00	0.26
SU4	STORAGE	0.28	0.30	80.17	1	00:00	0.30
SU5	STORAGE	0.26	0.29	80.22	0	01:43	0.29
SU6	STORAGE	0.00	0.03	79.28	0	01:11	0.03
SU7	STORAGE	0.00	0.02	79.43	0	01:10	0.02
SU8	STORAGE	0.00	0.01	78.83	0	01:10	0.01

Node Inflow Summary

Total Inflow Volume		Flow Balance Error	Type	Maximum Lateral Inflow	Maximum Total Inflow	Time of Max Occurrence	Lateral Inflow Volume
ltr	Percent			CMS	CMS	days hr:min	10^6 ltr
0.000777	-2.701		JUNCTION	0.000	0.002	0 01:23	0
0.0614	-0.015		JUNCTION	0.000	0.045	0 01:10	0
0.0438	0.075		JUNCTION	0.034	0.034	0 01:10	0.0436
0.0158	0.005		JUNCTION	0.000	0.011	0 01:11	0
0.0193	-0.086		JUNCTION	0.000	0.014	0 01:11	0
0.0243	-0.049		JUNCTION	0.000	0.007	0 01:15	0
0.0158	0.004		JUNCTION	0.000	0.011	0 01:11	0
0.00109	-5.276		JUNCTION	0.000	0.004	0 01:13	0
0.1	0.702		JUNCTION	0.000	0.085	0 01:11	0
0.00542	0.001		JUNCTION	0.000	0.005	0 01:10	0
0.0116	0.001		JUNCTION	0.000	0.010	0 01:10	0
			JUNCTION	0.000	0.014	0 01:11	0
			JUNCTION				0.

Ex-CBMH2		JUNCTION	0.000	0.085	0	01:11	0
0.0995	-0.084						
ExCBMH3		JUNCTION	0.000	0.033	0	01:10	0
0.0448	0.282						
ExMH103		JUNCTION	0.000	0.033	0	01:10	0
0.254	0.004						
ExSTMH		JUNCTION	0.000	0.011	0	01:11	0
0.0158	0.015						
Ex-STMH1		JUNCTION	0.000	0.176	0	04:00	0
0.00439	-53.491						
Ex-STMH9		JUNCTION	0.000	0.041	0	01:14	0
0.388	-0.034						
EX-STM-MH		JUNCTION	0.041	0.065	0	01:13	0.0552
0.44	0.001						
J1		JUNCTION	0.000	0.078	0	01:11	0
0.143	-1.627						
J17		JUNCTION	0.000	0.141	0	03:59	0
0.058	-17.460						
J2		JUNCTION	0.000	0.104	0	01:11	0
0.207	-0.324						
J20		JUNCTION	0.000	0.098	0	03:33	0
0.102	-1.752						
J25		JUNCTION	0.000	0.019	0	01:11	0
0.0294	1.541						
J26		JUNCTION	0.000	0.025	0	01:13	0
0.0441	3.374						
J6		JUNCTION	0.000	0.094	0	01:11	0
0.251	0.114						
OGS-STMH201		JUNCTION	0.000	0.008	0	02:34	0
0.249	0.006						
STM01		JUNCTION	0.000	0.012	0	01:24	0
0.102	0.000						
STMMH202		JUNCTION	0.000	0.019	0	01:34	0
0.35	-0.005						
STMMH203		JUNCTION	0.000	0.012	0	01:24	0
0.102	0.003						
OF1		OUTFALL	0.000	0.065	0	01:13	0
0.44	0.000						
OF2		OUTFALL	0.010	0.010	0	01:05	0.0143
0.0143	0.000						
OF3		OUTFALL	0.074	0.074	0	01:10	0.124
0.124	0.000						
OF4		OUTFALL	0.059	0.059	0	01:10	0.0948
0.0948	0.000						
Roof-Storage		STORAGE	0.070	0.070	0	01:10	0.102
0.102	0.001						
SU1		STORAGE	0.004	0.004	0	01:10	0.00348
0.00348	-0.007						
SU10		STORAGE	0.120	0.120	0	01:10	0.164
0.164	0.012						
SU11_pr		STORAGE	0.036	0.036	0	01:10	0.0472
0.0472	0.012						
SU12_pr		STORAGE	0.045	0.045	0	01:10	0.0648
0.0648	-0.001						
SU13_pr		STORAGE	0.101	0.101	0	01:10	0.138
0.138	0.003						
SU2		STORAGE	0.058	0.058	0	01:10	0.0834
0.0834	0.012						
SU3		STORAGE	0.047	0.047	0	01:10	0.0677
0.0677	0.012						

SU4		STORAGE	0.051	0.051	0	01:10	0.0697
0.0697	0.012						
SU5		STORAGE	0.062	0.062	0	01:10	0.0818
0.0818	0.009						
SU6		STORAGE	0.012	0.012	0	01:10	0.0158
0.0158	0.000						
SU7		STORAGE	0.010	0.010	0	01:10	0.0116
0.0116	0.000						
SU8		STORAGE	0.005	0.005	0	01:10	0.00542
0.00542	0.000						

Node Surcharge Summary

Surcharging occurs when water rises above the top of the highest conduit.

Node	Type	Hours Surcharged	Max. Height Above Crown Meters	Min. Depth Below Rim Meters
CB201	JUNCTION	4.84	0.990	0.360
CB202	JUNCTION	3.67	0.791	0.559
CB203	JUNCTION	2.06	0.310	1.410
Ex-CB1	JUNCTION	5.42	1.081	0.389
Ex-CB3	JUNCTION	5.35	1.070	0.310
ExCB4	JUNCTION	4.80	0.961	0.409
Ex-CBMH1	JUNCTION	7.29	1.321	0.329
Ex-CBMH2	JUNCTION	5.67	1.101	0.319
ExCBMH3	JUNCTION	2.22	0.410	1.060
ExMH103	JUNCTION	2.61	0.570	0.870
Ex-STMH1	JUNCTION	1.94	0.230	0.610
J1	JUNCTION	2.49	0.537	0.646
J17	JUNCTION	2.44	0.515	0.610
J2	JUNCTION	2.50	0.540	0.764
J20	JUNCTION	2.47	0.530	0.610
J26	JUNCTION	0.10	0.023	1.774
J6	JUNCTION	2.61	0.570	0.820

Node Flooding Summary

No nodes were flooded.

Storage Volume Summary

Max Occurrence	Maximum Outflow	Average Volume	Avg Pcnt	Evap Pcnt	Exfil Pcnt	Maximum Volume	Max Pcnt	Time of
----------------	-----------------	----------------	----------	-----------	------------	----------------	----------	---------

Storage Unit hr:min	Unit CMS	1000 m ³	Full	Loss	Loss	1000 m ³	Full	days
Roof-Storage		0.009	9.6	0.0	0.0	0.056	58.8	0
01:24	0.012							
SU1		0.000	0.0	0.0	0.0	0.000	0.0	0
01:10	0.004							
SU10		0.149	0.3	0.0	0.0	0.164	0.4	1
00:00	0.000							
SU11_pr		0.043	0.3	0.0	0.0	0.047	0.3	1
00:00	0.000							
SU12_pr		0.004	0.0	0.0	0.0	0.007	0.1	0
01:10	0.045							
SU13_pr		0.037	0.2	0.0	0.0	0.055	0.4	0
01:11	0.085							
SU2		0.076	0.2	0.0	0.0	0.083	0.2	1
00:00	0.000							
SU3		0.061	0.2	0.0	0.0	0.068	0.3	1
00:00	0.000							
SU4		0.063	0.3	0.0	0.0	0.070	0.4	1
00:00	0.000							
SU5		0.056	0.3	0.0	0.0	0.066	0.3	0
01:43	0.006							
SU6		0.000	0.0	0.0	0.0	0.001	0.0	0
01:11	0.011							
SU7		0.000	0.0	0.0	0.0	0.000	0.0	0
01:10	0.010							
SU8		0.000	0.0	0.0	0.0	0.000	0.0	0
01:10	0.005							

 Outfall Loading Summary

Outfall Node	Flow Freq Pcnt	Avg Flow CMS	Max Flow CMS	Total Volume 10 ⁶ ltr
OF1	87.35	0.011	0.065	0.440
OF2	24.74	0.002	0.010	0.014
OF3	27.18	0.014	0.074	0.124
OF4	26.53	0.011	0.059	0.095
System	41.45	0.039	0.200	0.674

 Link Flow Summary

Link	Type	Maximum Flow CMS	Time of Max Occurrence days hr:min	Maximum Veloc m/sec	Max/ Full Flow	Max/ Full Depth
------	------	--------------------------	--	-----------------------------	----------------------	-----------------------

C9	1.00	0.04	0.01	0.00	0.75	0.21	0.00	0.00	0.13
0.00									
OR1	1.00	0.83	0.04	0.00	0.11	0.02	0.00	0.00	0.98
0.00									
OR10	1.00	0.01	0.99	0.00	0.00	0.00	0.00	0.00	0.00
0.00									
OR11	1.00	0.72	0.28	0.00	0.00	0.00	0.00	0.00	0.00
0.00									
OR12	1.00	0.03	0.00	0.00	0.94	0.03	0.00	0.00	0.97
0.00									
OR2	1.00	0.05	0.95	0.00	0.00	0.00	0.00	0.00	0.00
0.00									
OR3	1.00	0.05	0.95	0.00	0.00	0.00	0.00	0.00	0.00
0.00									
OR4	1.00	0.05	0.95	0.00	0.00	0.00	0.00	0.00	0.00
0.00									
OR5	1.00	0.05	0.01	0.00	0.84	0.10	0.00	0.00	0.94
0.00									
OR6	1.00	0.01	0.86	0.00	0.01	0.12	0.00	0.00	0.99
0.00									
OR7	1.00	0.01	0.00	0.00	0.87	0.12	0.00	0.00	0.99
0.00									
OR8	1.00	0.01	0.00	0.00	0.87	0.12	0.00	0.00	0.98
0.00									

 Conduit Surcharge Summary

Conduit	Hours Full			Hours	
	Both Ends	Upstream	Dnstream	Above Full Normal Flow	Capacity Limited
C1	4.79	4.80	5.67	0.12	0.08
C10	2.43	2.43	2.47	0.01	0.10
C11	5.35	5.35	5.78	0.01	0.01
C12	3.67	3.67	22.90	0.01	0.01
C12_1	2.47	2.47	2.49	0.01	0.26
C12_3	2.49	2.49	2.50	0.01	0.47
C12_4	2.50	2.50	2.61	0.01	0.01
C13	2.23	2.23	2.61	0.01	0.01
C15	0.01	0.01	23.83	0.01	0.01
C21	0.01	0.01	0.10	0.01	0.01
C22	0.01	0.01	0.10	0.01	0.01
C23	0.01	0.01	0.20	0.01	0.01
C24	0.01	0.01	0.67	0.01	0.01
C3	0.01	0.01	4.80	0.01	0.01
C4	4.84	4.84	22.75	0.01	0.01
C4_2	2.06	2.06	2.22	0.01	0.01
C5	2.61	2.61	2.69	0.01	0.01
C6	5.66	5.75	6.09	0.10	0.01
C7	1.94	1.94	2.43	0.01	0.01
C8	5.42	5.42	7.45	0.01	0.01
C9	7.29	7.29	10.50	0.01	0.01
OR12	0.01	0.01	3.67	0.01	0.01
OR5	0.01	0.01	5.36	0.01	0.01

Analysis begun on: Mon Jun 24 16:09:19 2024
Analysis ended on: Mon Jun 24 16:09:20 2024
Total elapsed time: 00:00:01

APPENDIX

F

Roof Drain Specifications

Engineering Specification

Job Name _____

Contractor _____

Job Location _____

Approval _____

Engineer _____

Contractor's P.O. No. _____

Approval _____

Representative _____

Tag _____

RD-300 High Volume Roof Drain Specification

Watts RD-300 epoxy coated cast iron roof drain with flashing clamp with integral gravel stop, self-locking polyethylene dome (standard), and no hub (standard) outlet.

Pipe Sizing		
Suffix	Description	
2	2"(51) Pipe Size (NH Only)	<input type="checkbox"/>
3	3"(76) Pipe Size	<input type="checkbox"/>
4	4"(102) Pipe Size	<input type="checkbox"/>
5	5"(127) Pipe Size (NH Only)	<input type="checkbox"/>
6	6"(152) Pipe Size	<input type="checkbox"/>
8	8"(203) Pipe Size	<input type="checkbox"/>
10	10"(254) Pipe Size (NH Only)	<input type="checkbox"/>



Outlet Type		
Suffix	Description	
NH	No Hub (MJ)	<input type="checkbox"/>
P	Push On	<input type="checkbox"/>
X	Inside Caulk	<input type="checkbox"/>

Options		
Suffix	Description	
-13	Galvanized Body & Clamp	<input type="checkbox"/>
-85	IRMA Perf. SS Extension	<input type="checkbox"/>
-AC	Compression Seal Extension	<input type="checkbox"/>
-AE	Threaded Extension	<input type="checkbox"/>
-B	Sump Receiver	<input type="checkbox"/>
-D	Underdeck Clamp	<input type="checkbox"/>
-F	Deck Flange/Adj. Extension	<input type="checkbox"/>
-GSS	Stainless Steel Ballast Guard	<input type="checkbox"/>
-K	Ductile Iron Dome	<input type="checkbox"/>
-K13	Galvanized Dome	<input type="checkbox"/>
-K40	Ductile Iron Low Dome (4" High)	<input type="checkbox"/>
-K80	Aluminum Dome	<input type="checkbox"/>
-K81	Rough Bronze Dome	<input type="checkbox"/>
-K83	SS Mesh Covered Dome	<input type="checkbox"/>
-L	Vandal Proof Dome	<input type="checkbox"/>
-R	2" External Water Dam	<input type="checkbox"/>
-W	Adj. Internal Water Dam	<input type="checkbox"/>

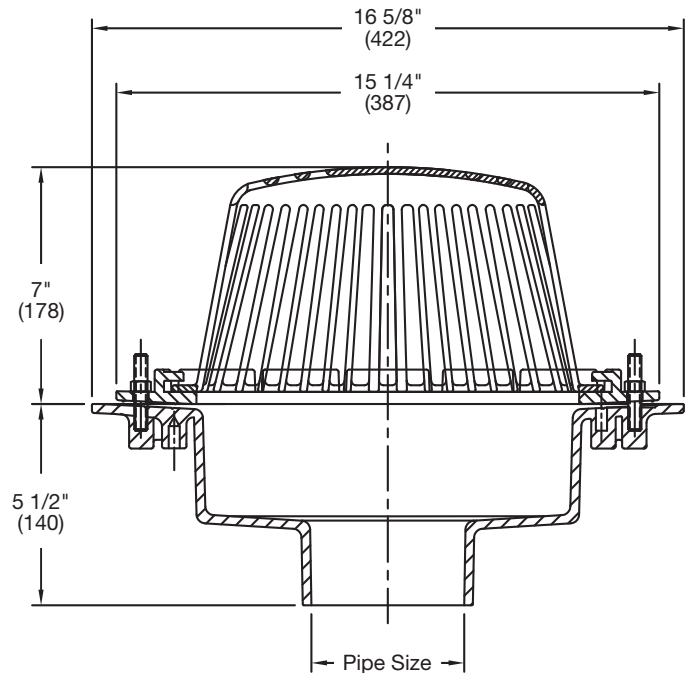

**Deck Opening 14 1/2"(368)
with Sump Receiver 18"(457)**

Free Area
Sq. In.
137

NOTICE

The information contained herein is not intended to replace the full product installation and safety information available or the experience of a trained product installer. You are required to thoroughly read all installation instructions and product safety information before beginning the installation of this product.

Watts product specifications in U.S. customary units and metric are approximate and are provided for reference only. For precise measurements, please contact Watts Technical Service. Watts reserves the right to change or modify product design, construction, specifications, or materials without prior notice and without incurring any obligation to make such changes and modifications on Watts products previously or subsequently sold.



USA: T: (800) 338-2581 • F: (828) 248-3929 • Watts.com
Canada: T: (888) 208-8927 • F: (905) 481-2316 • Watts.ca
Latin America: T: (52) 55-4122-0138 • Watts.com



Adjustable Accutrol Weir

Tag: _____

Adjustable Flow Control for Roof Drains

ADJUSTABLE ACCUTROL (for Large Sump Roof Drains only)

For more flexibility in controlling flow with heads deeper than 2", Watts Drainage offers the Adjustable Accutrol. The Adjustable Accutrol Weir is designed with a single parabolic opening that can be covered to restrict flow above 2" of head to less than 5 gpm per inch, up to 6" of head. To adjust the flow rate for depths over 2" of head, set the slot in the adjustable upper cone according to the flow rate required. Refer to Table 1 below.
 Note: Flow rates are directly proportional to the amount of weir opening that is exposed.

EXAMPLE:

For example, if the adjustable upper cone is set to cover 1/2 of the weir opening, flow rates above 2" of head will be restricted to 2-1/2 gpm per inch of head.

Therefore, at 3" of head, the flow rate through the Accutrol Weir that has 1/2 the slot exposed will be:
 [5 gpm (per inch of head) x 2 inches of head] + 2-1/2 gpm (for the third inch of head) = 12-1/2 gpm.

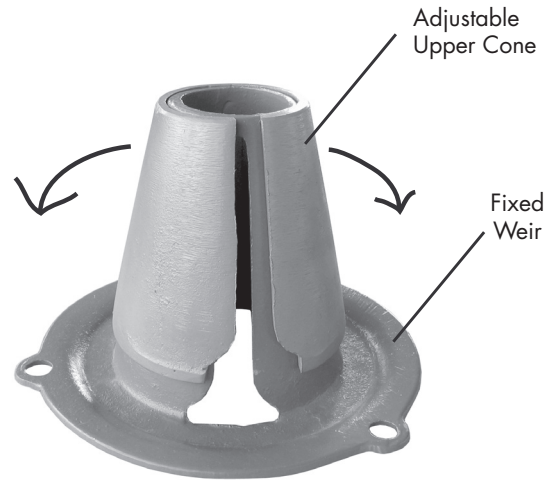
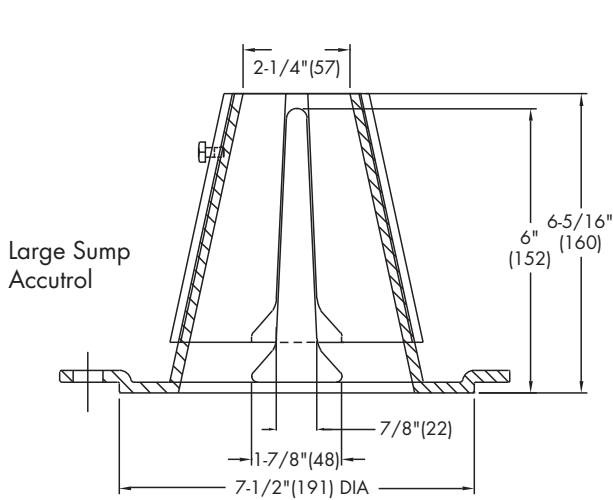

1/2 Weir Opening Exposed Shown Above

TABLE 1. Adjustable Accutrol Flow Rate Settings

Weir Opening Exposed	1"	2"	3"	4"	5"	6"
	Flow Rate (gallons per minute)					
Fully Exposed	5	10	15	20	25	30
3/4	5	10	13.75	17.5	21.25	25
1/2	5	10	12.5	15	17.5	20
1/4	5	10	11.25	12.5	13.75	15
Closed	5	5	5	5	5	5

Job Name _____
 Job Location _____
 Engineer _____

Contractor _____
 Contractor's P.O. No. _____
 Representative _____

Watts product specifications in U.S. customary units and metric are approximate and are provided for reference only. For precise measurements, please contact Watts Technical Service. Watts reserves the right to change or modify product design, construction, specifications, or materials without prior notice and without incurring any obligation to make such changes and modifications on Watts products previously or subsequently sold.

USA: Tel: (800) 338-2581 • Fax: (828) 248-3929 • Watts.com
 Canada: Tel: (905) 332-4090 • Fax: (905) 332-7068 • Watts.ca
 Latin America: Tel: (52) 81-1001-8600 • Fax: (52) 81-8000-7091 • Watts.com



A Watts Water Technologies Company

APPENDIX

G

OGS Sizing Report

Stormceptor® EF Sizing Report

Imbrium® Systems

ESTIMATED NET ANNUAL SEDIMENT (TSS) LOAD REDUCTION

06/21/2024

Province:	Ontario	Project Name:	St. Patrick's Home Ottawa
City:	Ottawa	Project Number:	221-08396-00
Nearest Rainfall Station:	OTTAWA CDA RCS	Designer Name:	Ding Bang Yang
Climate Station Id:	6105978	Designer Company:	WSP Canada Inc
Years of Rainfall Data:	20	Designer Email:	winston.yang@wsp.com
Site Name:	St Patrick's Home	Designer Phone:	613-690-0538
Drainage Area (ha):	1.255	EOR Name:	
% Imperviousness:	74.40	EOR Company:	
Runoff Coefficient 'c': 0.74		EOR Email:	
Particle Size Distribution:	Fine	EOR Phone:	
Target TSS Removal (%):	80.0		

Net Annual Sediment (TSS) Load Reduction Sizing Summary	
Stormceptor Model	TSS Removal Provided (%)
EFO4	81
EFO6	92
EFO8	98
EFO10	100
EFO12	100

Required Water Quality Runoff Volume Capture (%):	90.00
Estimated Water Quality Flow Rate (L/s):	30.23
Oil / Fuel Spill Risk Site?	Yes
Upstream Flow Control?	Yes
Upstream Orifice Control Flow Rate to Stormceptor (L/s):	8.00
Peak Conveyance (maximum) Flow Rate (L/s):	8.00
Influent TSS Concentration (mg/L):	200
Estimated Average Annual Sediment Load (kg/yr):	1029
Estimated Average Annual Sediment Volume (L/yr):	837

Recommended Stormceptor EFO Model:	EFO4
Estimated Net Annual Sediment (TSS) Load Reduction (%):	81
Water Quality Runoff Volume Capture (%):	> 90

THIRD-PARTY TESTING AND VERIFICATION

► **Stormceptor® EF and Stormceptor® EFO** are the latest evolutions in the Stormceptor® oil-grit separator (OGS) technology series, and are designed to remove a wide variety of pollutants from stormwater and snowmelt runoff. These technologies have been third-party tested in accordance with the Canadian ETV **Procedure for Laboratory Testing of Oil-Grit Separators** and performance has been third-party verified in accordance with the **ISO 14034 Environmental Technology Verification (ETV)** protocol.

PERFORMANCE

► **Stormceptor® EF and EFO** remove stormwater pollutants through gravity separation and floatation, and feature a patent-pending design that generates positive removal of total suspended solids (TSS) throughout each storm event, including high-intensity storms. Captured pollutants include sediment, free oils, and sediment-bound pollutants such as nutrients, heavy metals, and petroleum hydrocarbons. Stormceptor is sized to remove a high level of TSS from the frequent rainfall events that contribute the vast majority of annual runoff volume and pollutant load. The technology incorporates an internal bypass to convey excessive stormwater flows from high-intensity storms through the device without resuspension and washout (scour) of previously captured pollutants. Proper routine maintenance ensures high pollutant removal performance and protection of downstream waterways.

PARTICLE SIZE DISTRIBUTION (PSD)

► The **Canadian ETV PSD** shown in the table below was used, or in part, for this sizing. This is the identical PSD that is referenced in the Canadian ETV **Procedure for Laboratory Testing of Oil-Grit Separators** for both sediment removal testing and scour testing. The Canadian ETV PSD contains a wide range of particle sizes in the sand and silt fractions, and is considered reasonably representative of the particle size fractions found in typical urban stormwater runoff.

Particle Size (µm)	Percent Less Than	Particle Size Fraction (µm)	Percent
1000	100	500-1000	5
500	95	250-500	5
250	90	150-250	15
150	75	100-150	15
100	60	75-100	10
75	50	50-75	5
50	45	20-50	10
20	35	8-20	15
8	20	5-8	10
5	10	2-5	5
2	5	<2	5

Stormceptor® EF Sizing Report

Upstream Flow Controlled Results

Rainfall Intensity (mm / hr)	Percent Rainfall Volume (%)	Cumulative Rainfall Volume (%)	Flow Rate (L/s)	Flow Rate (L/min)	Surface Loading Rate (L/min/m²)	Removal Efficiency (%)	Incremental Removal (%)	Cumulative Removal (%)
0.50	8.6	8.6	1.30	78.0	65.0	100	8.6	8.6
1.00	20.3	29.0	2.60	156.0	130.0	92	18.7	27.3
2.00	16.2	45.2	5.21	312.0	260.0	80	13.0	40.4
3.00	54.8	100.0	7.81	469.0	391.0	74	40.7	81.1
4.00	0.0	100.0	8.00	480.0	400.0	74	0.0	81.1
5.00	0.0	100.0	8.00	480.0	400.0	74	0.0	81.1
6.00	0.0	100.0	8.00	480.0	400.0	74	0.0	81.1
7.00	0.0	100.0	8.00	480.0	400.0	74	0.0	81.1
8.00	0.0	100.0	8.00	480.0	400.0	74	0.0	81.1
9.00	0.0	100.0	8.00	480.0	400.0	74	0.0	81.1
10.00	0.0	100.0	8.00	480.0	400.0	74	0.0	81.1
11.00	0.0	100.0	8.00	480.0	400.0	74	0.0	81.1
12.00	0.0	100.0	8.00	480.0	400.0	74	0.0	81.1
13.00	0.0	100.0	8.00	480.0	400.0	74	0.0	81.1
14.00	0.0	100.0	8.00	480.0	400.0	74	0.0	81.1
15.00	0.0	100.0	8.00	480.0	400.0	74	0.0	81.1
16.00	0.0	100.0	8.00	480.0	400.0	74	0.0	81.1
17.00	0.0	100.0	8.00	480.0	400.0	74	0.0	81.1
18.00	0.0	100.0	8.00	480.0	400.0	74	0.0	81.1
19.00	0.0	100.0	8.00	480.0	400.0	74	0.0	81.1
20.00	0.0	100.0	8.00	480.0	400.0	74	0.0	81.1
21.00	0.0	100.0	8.00	480.0	400.0	74	0.0	81.1
22.00	0.0	100.0	8.00	480.0	400.0	74	0.0	81.1
23.00	0.0	100.0	8.00	480.0	400.0	74	0.0	81.1
24.00	0.0	100.0	8.00	480.0	400.0	74	0.0	81.1
25.00	0.0	100.0	8.00	480.0	400.0	74	0.0	81.1
30.00	0.0	100.0	8.00	480.0	400.0	74	0.0	81.1
35.00	0.0	100.0	8.00	480.0	400.0	74	0.0	81.1
40.00	0.0	100.0	8.00	480.0	400.0	74	0.0	81.1
45.00	0.0	100.0	8.00	480.0	400.0	74	0.0	81.1
Estimated Net Annual Sediment (TSS) Load Reduction =								81 %

Climate Station ID: 6105978 Years of Rainfall Data: 20

Stormceptor® EF Sizing Report

RAINFALL DATA FROM OTTAWA CDA RCS RAINFALL STATION

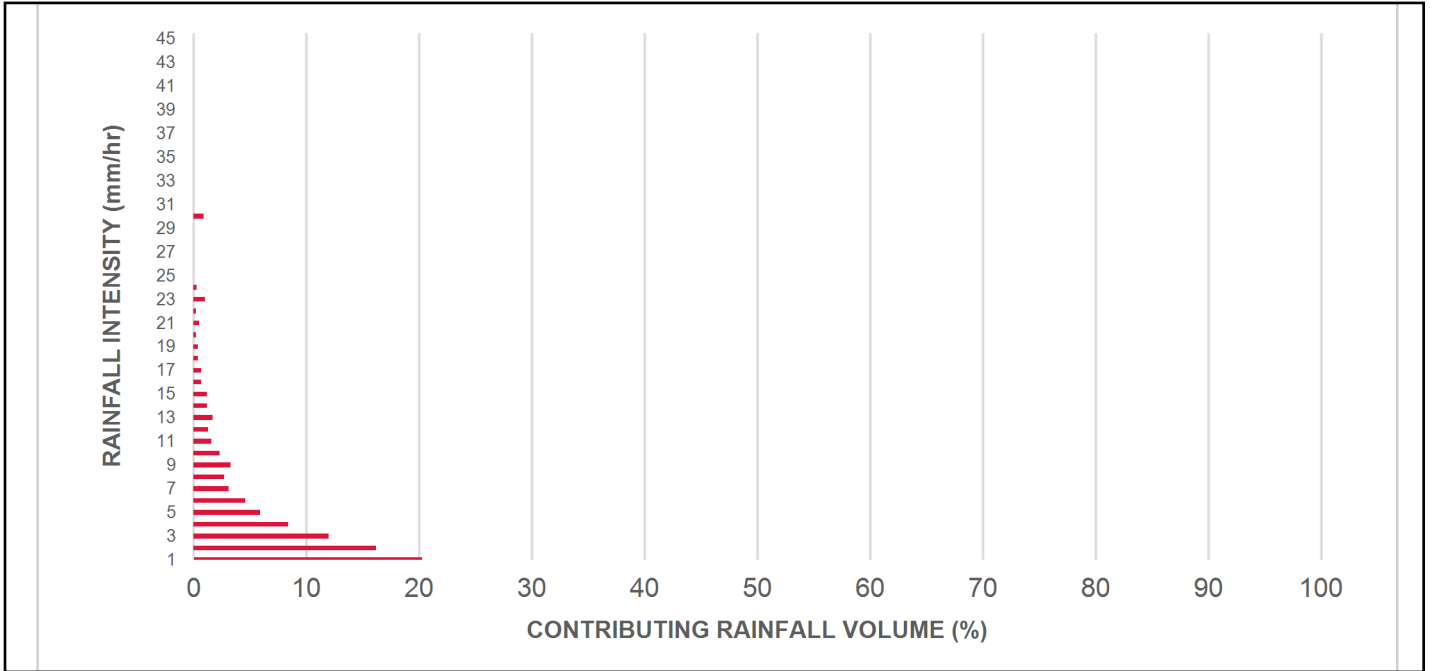

INCREMENTAL AND CUMULATIVE TSS REMOVAL FOR THE RECOMMENDED STORMCEPTOR® MODEL

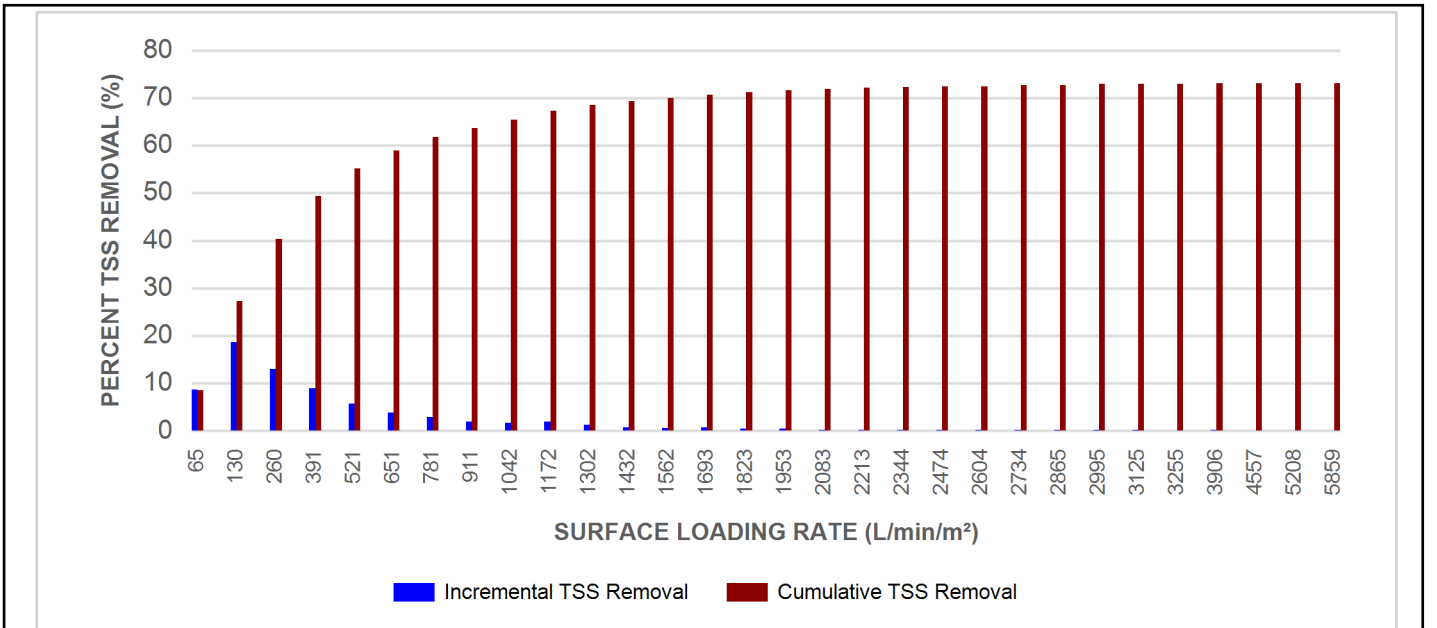

Stormceptor® EF Sizing Report

Maximum Pipe Diameter / Peak Conveyance

Stormceptor EF / EFO	Model Diameter		Min Angle Inlet / Outlet Pipes	Max Inlet Pipe Diameter		Max Outlet Pipe Diameter		Peak Conveyance Flow Rate	
	(m)	(ft)		(mm)	(in)	(mm)	(in)	(L/s)	(cfs)
EF4 / EFO4	1.2	4	90	609	24	609	24	425	15
EF6 / EFO6	1.8	6	90	914	36	914	36	990	35
EF8 / EFO8	2.4	8	90	1219	48	1219	48	1700	60
EF10 / EFO10	3.0	10	90	1828	72	1828	72	2830	100
EF12 / EFO12	3.6	12	90	1828	72	1828	72	2830	100

SCOUR PREVENTION AND ONLINE CONFIGURATION

► Stormceptor® EF and EFO feature an internal bypass and superior scour prevention technology that have been demonstrated in third-party testing according to the scour testing provisions of the Canadian ETV **Procedure for Laboratory Testing of Oil-Grit Separators**, and the exceptional scour test performance has been third-party verified in accordance with the ISO 14034 ETV protocol. As a result, Stormceptor EF and EFO are approved for online installation, eliminating the need for costly additional bypass structures, piping, and installation expense.

DESIGN FLEXIBILITY

► Stormceptor® EF and EFO offers design flexibility in one simplified platform, accepting stormwater flow from a single inlet pipe or multiple inlet pipes, and/or surface runoff through an inlet grate. The device can also serve as a junction structure, accommodate a 90-degree inlet-to-outlet bend angle, and can be modified to ensure performance in submerged conditions.

OIL CAPTURE AND RETENTION

► While Stormceptor® EF will capture and retain oil from dry weather spills and low intensity runoff, Stormceptor® EFO has demonstrated superior oil capture and greater than 99% oil retention in third-party testing according to the light liquid re-entrainment testing provisions of the Canadian ETV **Procedure for Laboratory Testing of Oil-Grit Separators**. Stormceptor EFO is recommended for sites where oil capture and retention is a requirement.

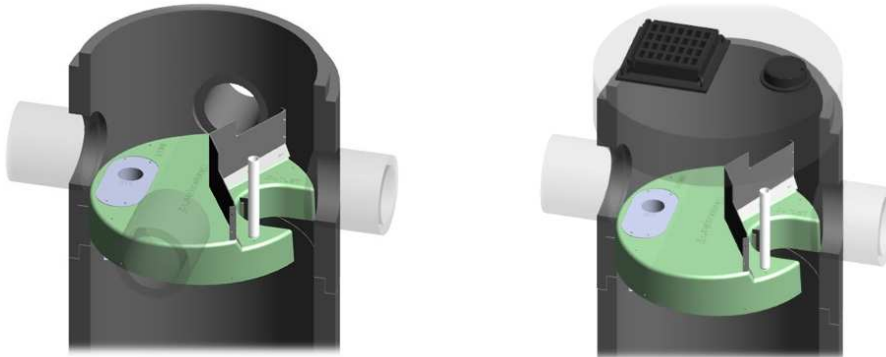

Stormceptor® EF Sizing Report

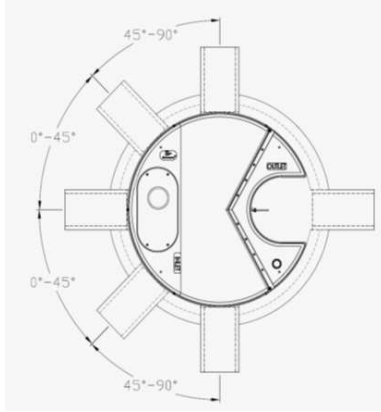

INLET-TO-OUTLET DROP

Elevation differential between inlet and outlet pipe inverts is dictated by the angle at which the inlet pipe(s) enters the unit.

0° - 45° : The inlet pipe is 1-inch (25mm) higher than the outlet pipe.

45° - 90° : The inlet pipe is 2-inches (50mm) higher than the outlet pipe.

HEAD LOSS

The head loss through Stormceptor EF is similar to that of a 60-degree bend structure. The applicable K value for calculating minor losses through the unit is 1.1. For submerged conditions the applicable K value is 3.0.

Pollutant Capacity

Stormceptor EF / EFO	Model Diameter		Depth (Outlet Pipe Invert to Sump Floor)		Oil Volume		Recommended Sediment Maintenance Depth *		Maximum Sediment Volume *		Maximum Sediment Mass **	
	(m)	(ft)	(m)	(ft)	(L)	(Gal)	(mm)	(in)	(L)	(ft³)	(kg)	(lb)
EF4 / EFO4	1.2	4	1.52	5.0	265	70	203	8	1190	42	1904	5250
EF6 / EFO6	1.8	6	1.93	6.3	610	160	305	12	3470	123	5552	15375
EF8 / EFO8	2.4	8	2.59	8.5	1070	280	610	24	8780	310	14048	38750
EF10 / EFO10	3.0	10	3.25	10.7	1670	440	610	24	17790	628	28464	78500
EF12 / EFO12	3.6	12	3.89	12.8	2475	655	610	24	31220	1103	49952	137875

*Increased sump depth may be added to increase sediment storage capacity

** Average density of wet packed sediment in sump = 1.6 kg/L (100 lb/ft³)

Feature	Benefit	Feature Appeals To
Patent-pending enhanced flow treatment and scour prevention technology	Superior, verified third-party performance	Regulator, Specifying & Design Engineer
Third-party verified light liquid capture and retention for EFO version	Proven performance for fuel/oil hotspot locations	Regulator, Specifying & Design Engineer, Site Owner
Functions as bend, junction or inlet structure	Design flexibility	Specifying & Design Engineer
Minimal drop between inlet and outlet	Site installation ease	Contractor
Large diameter outlet riser for inspection and maintenance	Easy maintenance access from grade	Maintenance Contractor & Site Owner

STANDARD STORMCEPTOR EF/EFO DRAWINGS

For standard details, please visit <http://www.imbriumsystems.com/stormwater-treatment-solutions/stormceptor-ef>

STANDARD STORMCEPTOR EF/EFO SPECIFICATION

For specifications, please visit <http://www.imbriumsystems.com/stormwater-treatment-solutions/stormceptor-ef>

STANDARD PERFORMANCE SPECIFICATION FOR “OIL GRIT SEPARATOR” (OGS) STORMWATER QUALITY TREATMENT DEVICE

PART 1 – GENERAL

1.1 WORK INCLUDED

This section specifies requirements for selecting, sizing, and designing an underground Oil Grit Separator (OGS) device for stormwater quality treatment, with third-party testing results and a Statement of Verification in accordance with ISO 14034 Environmental Management – Environmental Technology Verification (ETV).

1.2 REFERENCE STANDARDS & PROCEDURES

ISO 14034:2016 Environmental management – Environmental technology verification (ETV)

Canadian Environmental Technology Verification (ETV) Program’s **Procedure for Laboratory Testing of Oil-Grit Separators**

1.3 SUBMITTALS

1.3.1 All submittals, including sizing reports & shop drawings, shall be submitted upon request with each order to the contractor then forwarded to the Engineer of Record for review and acceptance. Shop drawings shall detail all OGS components, elevations, and sequence of construction.

1.3.2 Alternative devices shall have features identical to or greater than the specified device, including: treatment chamber diameter, treatment chamber wet volume, sediment storage volume, and oil storage volume.

1.3.3 Unless directed otherwise by the Engineer of Record, OGS stormwater quality treatment product substitutions or alternatives submitted within ten days prior to project bid shall not be accepted. All alternatives or substitutions submitted shall be signed and sealed by a local registered Professional Engineer, based on the exact same criteria detailed in Section 3, in entirety, subject to review and approval by the Engineer of Record.

PART 2 – PRODUCTS

2.1 OGS POLLUTANT STORAGE

The OGS device shall include a sump for sediment storage, and a protected volume for the capture and storage of petroleum hydrocarbons and buoyant gross pollutants. The minimum sediment & petroleum hydrocarbon storage capacity shall be as follows:

2.1.1	4 ft (1219 mm) Diameter OGS Units:	1.19 m ³ sediment / 265 L oil
	6 ft (1829 mm) Diameter OGS Units:	3.48 m ³ sediment / 609 L oil
	8 ft (2438 mm) Diameter OGS Units:	8.78 m ³ sediment / 1,071 L oil
	10 ft (3048 mm) Diameter OGS Units:	17.78 m ³ sediment / 1,673 L oil
	12 ft (3657 mm) Diameter OGS Units:	31.23 m ³ sediment / 2,476 L oil

PART 3 – PERFORMANCE & DESIGN

3.1 GENERAL

The OGS stormwater quality treatment device shall be verified in accordance with ISO 14034:2016 Environmental management – Environmental technology verification (ETV). The OGS stormwater quality treatment device shall

Stormceptor® EF Sizing Report

remove oil, sediment and gross pollutants from stormwater runoff during frequent wet weather events, and retain these pollutants during less frequent high flow wet weather events below the insert within the OGS for later removal during maintenance. The Manufacturer shall have at least ten (10) years of local experience, history and success in engineering design, manufacturing and production and supply of OGS stormwater quality treatment device systems, acceptable to the Engineer of Record.

3.2 SIZING METHODOLOGY

The OGS device shall be engineered, designed and sized to provide stormwater quality treatment based on treating a minimum of 90 percent of the average annual runoff volume and a minimum removal of an annual average 60% of the sediment (TSS) load based on the Particle Size Distribution (PSD) specified in the sizing report for the specified device. Sizing of the OGS shall be determined by use of a minimum ten (10) years of local historical rainfall data provided by Environment Canada. Sizing shall also be determined by use of the sediment removal performance data derived from the ISO 14034 ETV third-party verified laboratory testing data from testing conducted in accordance with the Canadian ETV protocol Procedure for Laboratory Testing of Oil-Grit Separators, as follows:

3.2.1 Sediment removal efficiency for a given surface loading rate and its associated flow rate shall be based on sediment removal efficiency demonstrated at the seven (7) tested surface loading rates specified in the protocol, ranging 40 L/min/m² to 1400 L/min/m², and as stated in the ISO 14034 ETV Verification Statement for the OGS device.

3.2.2 Sediment removal efficiency for surface loading rates between 40 L/min/m² and 1400 L/min/m² shall be based on linear interpolation of data between consecutive tested surface loading rates.

3.2.3 Sediment removal efficiency for surface loading rates less than the lowest tested surface loading rate of 40 L/min/m² shall be assumed to be identical to the sediment removal efficiency at 40 L/min/m². No extrapolation shall be allowed that results in a sediment removal efficiency that is greater than that demonstrated at 40 L/min/m².

3.2.4 Sediment removal efficiency for surface loading rates greater than the highest tested surface loading rate of 1400 L/min/m² shall assume zero sediment removal for the portion of flow that exceeds 1400 L/min/m², and shall be calculated using a simple proportioning formula, with 1400 L/min/m² in the numerator and the higher surface loading rate in the denominator, and multiplying the resulting fraction times the sediment removal efficiency at 1400 L/min/m².

The OGS device shall also have sufficient annual sediment storage capacity as specified and calculated in Section 2.1.

3.3 CANADIAN ETV or ISO 14034 ETV VERIFICATION OF SCOUR TESTING

The OGS device shall have Canadian ETV or ISO 14034 ETV Verification of third-party scour testing conducted in accordance with the Canadian ETV Program's **Procedure for Laboratory Testing of Oil-Grit Separators**.

3.3.1 To be acceptable for on-line installation, the OGS device must demonstrate an average scour test effluent concentration less than 10 mg/L at each surface loading rate tested, up to and including 2600 L/min/m².

3.4 LIGHT LIQUID RE-ENTRAINMENT SIMULATION TESTING

The OGS device shall have Canadian ETV or ISO 14034 ETV Verification of completed third-party Light Liquid Re-entrainment Simulation Testing in accordance with the Canadian ETV **Program's Procedure for Laboratory Testing of Oil-Grit Separators**, with results reported within the Canadian ETV or ISO 14034 ETV verification. This re-entrainment testing is conducted with the device pre-loaded with low density polyethylene (LDPE) plastic beads as a surrogate for light liquids such as oil and fuel. Testing is conducted on the same OGS unit tested for sediment removal to

Stormceptor® EF Sizing Report

assess whether light liquids captured after a spill are effectively retained at high flow rates.

3.4.1 For an OGS device to be an acceptable stormwater treatment device on a site where vehicular traffic occurs and the potential for an oil or fuel spill exists, the OGS device must have reported verified performance results of greater than 99% cumulative retention of LDPE plastic beads for the five specified surface loading rates (ranging 200 L/min/m² to 2600 L/min/m²) in accordance with the Light Liquid Re-entrainment Simulation Testing within the Canadian ETV Program's **Procedure for Laboratory Testing of Oil-Grit Separators**. However, an OGS device shall not be allowed if the Light Liquid Re-entrainment Simulation Testing was performed with screening components within the OGS device that are effective at retaining the LDPE plastic beads, but would not be expected to retain light liquids such as oil and fuel.

