



**SITE SERVICING AND STORMWATER
MANAGEMENT REPORT - 100 STEACIE
DRIVE**

August 9, 2024

Prepared for:
11034936 Canada Inc.

Prepared by:
Stantec Consulting Ltd.

Project Number:
160401570

Site Servicing and Stormwater Management Report - 100 Steacie Drive

Revision	Description	Author	Date	Quality Check	Date	Independent Review	Date
0	1 st Submission	Michael W.	2024-04-05	Dustin T.	2024-04-05	Kris K.	2024-04-05
1	2 nd Submission	Michael W.	2024-07-29	Dustin T.	2024-08-09	Kris K.	2024-08-02



Site Servicing and Stormwater Management Report - 100 Steacie Drive

The conclusions in the Report titled Site Servicing and Stormwater Management Report - 100 Steacie Drive are Stantec's professional opinion, as of the time of the Report, and concerning the scope described in the Report. The opinions in the document are based on conditions and information existing at the time the scope of work was conducted and do not take into account any subsequent changes. The Report relates solely to the specific project for which Stantec was retained and the stated purpose for which the Report was prepared. The Report is not to be used or relied on for any variation or extension of the project, or for any other project or purpose, and any unauthorized use or reliance is at the recipient's own risk.

Stantec has assumed all information received from 11034936 Canada Inc. (the "Client") and third parties in the preparation of the Report to be correct. While Stantec has exercised a customary level of judgment or due diligence in the use of such information, Stantec assumes no responsibility for the consequences of any error or omission contained therein.

This Report is intended solely for use by the Client in accordance with Stantec's contract with the Client. While the Report may be provided by the Client to applicable authorities having jurisdiction and to other third parties in connection with the project, Stantec disclaims any legal duty based upon warranty, reliance or any other theory to any third party, and will not be liable to such third party for any damages or losses of any kind that may result.

Prepared by: 
Signature

Michael Wu, EIT
Printed Name

Reviewed by: 
Signature

Dustin Thiffault, P.Eng
Printed Name

Approved by: 
Signature

Kris Kilborn



Table of Contents

1	INTRODUCTION	1.1
1.1	Objective.....	1.1
2	BACKGROUND.....	2.3
3	WATER SUPPLY SERVICING.....	3.1
3.1	Background	3.1
3.1.1	Domestic Water Demands	3.1
3.1.2	Fire Flow Demands	3.1
3.1.3	Boundary Conditions	3.2
3.2	Proposed Watermain Servicing and Layout.....	3.2
3.3	Hydraulic Assessment.....	3.2
3.3.1	Level of Service	3.2
3.3.2	Model Development.....	3.3
3.4	Hydraulic Model Results.....	3.3
3.4.1	Average Day Demand (AVDY).....	3.3
3.4.2	Peak Hour Demand (PKHR)	3.4
3.4.3	Maximum Day Demand + Fire Flow (MXDY+FF)	3.5
3.5	Conclusion.....	3.6
4	WASTEWATER SERVICING	4.7
4.1	Background	4.7
4.2	Design Criteria.....	4.7
4.3	Wastewater Generation and Servicing Design	4.7
4.4	Proposed Servicing	4.8
5	STORMWATER MANAGEMENT.....	5.9
5.1	Objectives	5.9
5.2	SWM Criteria and Constraints	5.9
5.3	Existing Conditions	5.10
5.4	Stormwater Management Design.....	5.11
5.4.1	Quantity Control: Storage Requirements	5.11
5.4.2	Results.....	5.13
5.4.3	Quality Control.....	5.14
6	GRADING AND DRAINAGE	6.16
7	UTILITIES.....	7.16
8	APPROVALS	8.16
9	EROSION CONTROL DURING CONSTRUCTION	9.17
10	GEOTECHNICAL INVESTIGATION	10.17
11	CONCLUSIONS	1
11.1	Water Servicing	1
11.2	Sanitary Servicing.....	1
11.3	Stormwater Servicing	1
11.4	Grading	1
11.5	Utilities	2



Site Servicing and Stormwater Management Report - 100 Steacie Drive

11.6	Approvals/Permits	2
------	-------------------------	---

LIST OF TABLES

Table 3.1:	Estimated Water Demands	3.1
Table 3.2:	Boundary Conditions	3.2
Table 3.3:	Proposed Watermain C-Factors	3.3
Table 4.1:	Estimated Total Wastewater Peak Flow	4.7
Table 5.1:	Target Release Rate	5.11
Table 5.2:	100 Year Summary of Roof Controls	5.12
Table 5.3:	Surface Storage Areas - 100 Year Event	5.13
Table 5.4:	Uncontrolled Non-Tributary Area (UNC-1 to UNC-4).....	5.13
Table 5.5:	Summary 2 Year and 100 Year Event Release Rates	5.14
Table 5.6:	Surface Area and Runoff for Stormceptor Sizing.....	5.15

LIST OF FIGURES

Figure 1.1:	Location Plan	1.1
Figure 3-3:	AVDY Pressure Results (psi)	3.4
Figure 3-4:	PKHR Pressure Results (psi)	3.5
Figure 3-5:	MXDY+FF Residual Pressures (psi)	3.6

LIST OF APPENDICES

APPENDIX A	WATER SERVICING	1
A.1	Water Demands.....	1
A.2	FUS Fire Flow Calculations	2
A.3	Boundary Conditions	3
A.4	H2OMap Hydraulic Analysis Results.....	4
APPENDIX B	SANITARY SERVICING.....	5
B.1	Sanitary Design Sheet.....	5
APPENDIX C	STORMWATER SERVICING AND MANAGEMENT	6
C.1	Storm Sewer Design Sheet	6
C.2	MRM Analysis.....	7
C.3	Stormceptor Sizing Report	8
APPENDIX D	EXTERNAL REPORTS	9



1 INTRODUCTION

Stantec Consulting Ltd. has been commissioned by 11034936 Canada Inc. to prepare the following Site Servicing and Stormwater Management Report in support of a Site Plan Control application for the proposed development located at 100 Steacie Drive in the City of Ottawa.

The site is 2.2 ha in area and is situated approximately 250 m southwest from the March Road and Station Road intersection, on the west end of Steacie Drive and the south side of the Canadian National Railway Renfrew Subdivision. The site is currently zoned R4Y [2809] S463-h, O1, and O1R and is presently vacant. The site is bounded by the CN Rail Renfrew Subdivision to the north, Steacie Drive and existing industrial development to the east, greenspace, and existing residential development to the south and west, as shown on **Figure 1.1** below.

Figure 1.1: Location Plan

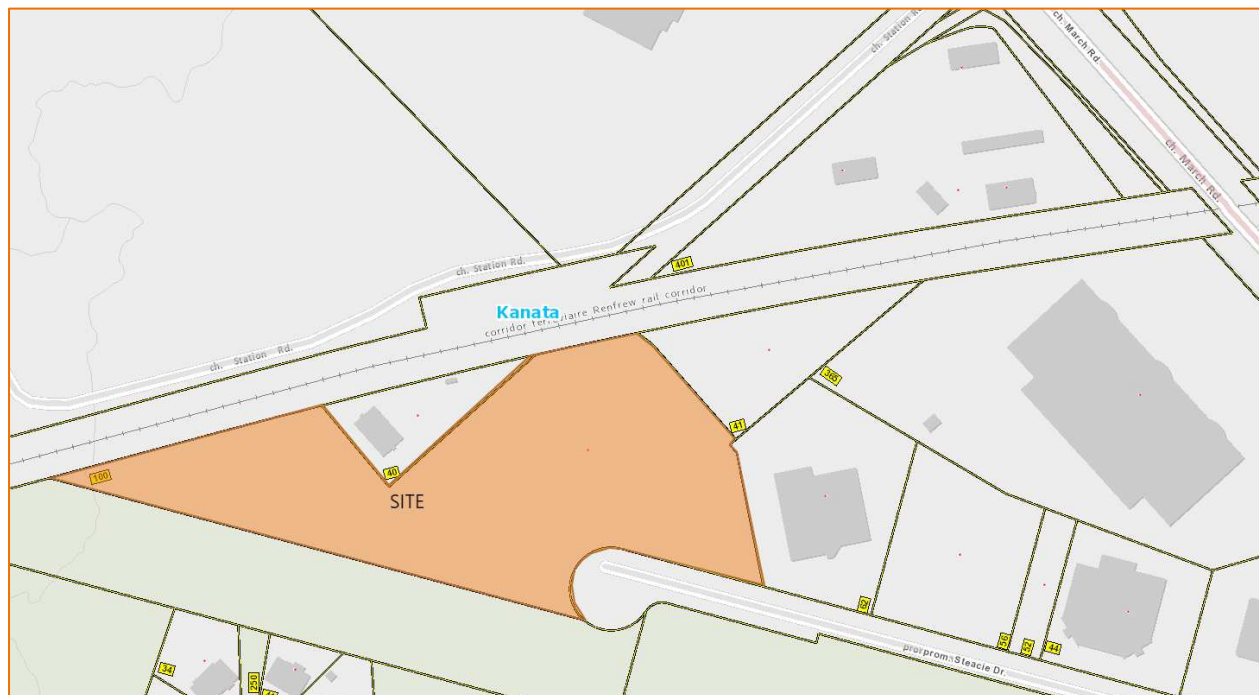

The proposed 2.2 ha site consists of two 4-storey medium rise residential buildings which would function as retirement facilities. Neuf has prepared a site plan and design brief dated February 16, 2024, in which the two buildings are proposed to have a total of 214 apartment units.

1.1 Objective

This site servicing and stormwater management (SWM) report presents a servicing scheme that is free of conflicts, provides on-site servicing in accordance with City of Ottawa Design Guidelines, and uses the



Site Servicing and Stormwater Management Report - 100 Steacie Drive

existing municipal infrastructure in accordance with any limitations communicated during consultation with the City of Ottawa staff. Details of the existing infrastructure located within Steacie Drive and Station Road right of ways (ROW) were obtained from available as-built drawings and site topographic survey.

Criteria and constraints provided by the City of Ottawa have been used as a basis for the detailed servicing design of the proposed development. Specific and potential development constraints to be addressed are as follows:

- Potable Water Servicing
 - Estimated water demands to characterize the proposed feed(s) for the proposed development which will be serviced from the 200 mm diameter watermains on Steacie Drive and Station Road.
 - Watermain servicing for the development is to be able to provide average day and maximum day (including peak hour) demands (i.e., non-emergency conditions) at pressures within the acceptable range of 345 to 552 kPa (50 to 80 psi)
 - Under fire flow (emergency) conditions, the water distribution system is to maintain a minimum pressure greater than 140 kPa (20 psi)
- Wastewater (Sanitary) Servicing
 - Define and size the on-site sanitary sewers which will be connected to the existing 250 mm diameter sanitary sewers within the Steacie Drive ROW.
- Storm Sewer Servicing
 - Define major and minor conveyance systems in conjunction with the proposed grading plan.
 - Determine the stormwater management storage requirements to meet the allowable release rate for the site.
 - Define and size the on-site storm sewers that will contribute to the existing ditches along the CN Rail Renfrew Subdivision.
- Prepare a grading plan in accordance with the proposed site plan and existing grades.

Drawing SSP-1 illustrate the proposed internal servicing scheme for the site.



2 Background

The following background studies have been referenced during the servicing and stormwater management design of the proposed site:

- *Geotechnical Investigation Proposed Residential Development, Steacie Drive, Kanata, ON*, Morey Houle Chevrier Engineering LTD., May 2005
- City of Ottawa Design Guidelines – Water Distribution, Infrastructure Services Department, City of Ottawa, First Edition, July 2010
- City of Ottawa Sewer Design Guidelines, 2nd Ed., City of Ottawa, October 2012
- Technical Bulletin ISTB-2018-01 Revision to Ottawa Design Guidelines – Sewer, City of Ottawa, March 2018
- Technical Bulletin ISTB-2018-02 Revision to Ottawa Design Guidelines – Water Distribution, City of Ottawa, March 2018
- *Site Servicing and Stormwater Management Report – 100 Steacie Drive (Functional)*, Revision 3, Stantec Consulting Ltd., March 2022



3 WATER SUPPLY SERVICING

3.1 Background

The proposed development is in Pressure Zone 2W2C of the City of Ottawa’s Water Distribution System. The existing watermain within the vicinity of the site comprises of the 200 mm diameter watermain stub on Station Road and the existing 200 mm diameter watermain on Steacie Drive.

3.1.1 DOMESTIC WATER DEMANDS

The City of Ottawa Water Distribution Guidelines (July 2010) and ISTB 2021-03 Technical Bulletin were used to determine water demands based on projected population densities for residential areas and associated peaking factors. The population was estimated using an occupancy of 1.8 persons per unit for apartments. Based on the unit count of 214 apartments, the proposed buildings are estimated to have a total population of 385 persons.

A daily rate of 280 L/cap/day has been used to estimate average daily (AVDY) potable water demand for the residential units. Maximum day (MXDY) demands were determined by multiplying the AVDY demands by a factor of 2.5 for residential areas. Peak hourly (PKHR) demands were determined by multiplying the MXDY by a factor of 2.2 for residential areas. The estimated demands are summarized in **Table 3.1** below and detailed in **Appendix A.1**.

Table 3.1: Estimated Water Demands

Total Apartment Units	Population	AVDY (L/s)	MXDY (L/s)	PKHR (L/s)
214	385	1.3	3.1	6.9

3.1.2 FIRE FLOW DEMANDS

The fire flow requirement for the development was calculated in accordance with Fire Underwriters Survey (FUS) methodology. Per Section 3.2.2.48A of the Ontario Building Code, the building was assumed to be non-combustible construction in the assessment for fire flow requirements according to the Fire Underwriters Survey (FUS) Guidelines.

Required fire flows were estimated based on a building of non-combustible construction type without full protections of all vertical openings (one hour fire rating), and a final sprinkler design to conform to the NFPA 13 standard. The gross floor area of the two largest floors + 50 % of the gross floor area of the additional floors were used in the FUS calculation for the two high-rises, as per Page 22 of the *Fire Underwriters Survey's Water Supply for Public Fire Protection* (2020).



The building's minimum required fire flow was determined to be 150 L/s (9,000 L/min). Detailed fire flow calculations per the FUS methodology are provided in **Appendix A.2**.

3.1.3 BOUNDARY CONDITIONS

The estimated domestic water demands, and fire flow demands were used to define the level of servicing required for the proposed development from the municipal watermain and hydrants within the Station Road and Seacie Drive ROWs. **Table 3.2** below outlines the boundary conditions for the two proposed connections servicing the site provided by the City of Ottawa on September 2, 2020, and shown in **Appendix A.3**.

Table 3.2: Boundary Conditions

Connection	Steacie Drive	Station Road
Min. HGL (m)	131.3	131.2
Max. HGL (m)	127.4	127.2
MXDY+FF (183.3 L/s) (m)	118.9	123.3

3.2 Proposed Watermain Servicing and Layout

The proposed watermain alignment and sizing for the development has been designed to tie into the existing watermains on Steacie Drive and Station Road and to provide the required domestic and fire flows.

The building itself will be directly serviced by the 200 mm diameter watermain stub on Steacie Drive via two 150 mm diameter water service laterals, separated by an isolation valve. A new 200 mm diameter watermain is proposed to connect the existing stub on Steacie Drive to the existing watermain on Station Road to provide the necessary fire flows to the development and for looping. **Drawings SSP-1** and **SSP-2** details the proposed watermain design and connections.

3.3 Hydraulic Assessment

3.3.1 LEVEL OF SERVICE

The City of Ottawa Water Distribution Design Guidelines state that the desired range of system pressures under normal demand conditions (i.e. basic day, maximum day and peak hour) should be in the range of 350 to 552 kPa (50 to 80 psi) and no less than 275 kPa (40 psi) at the ground elevation in the streets (i.e. at hydrant level). The maximum pressure at any point in the distribution system in occupied areas outside of the public right-of-way is 552 kPa (80 psi).

As per the OBC & Guide for Plumbing, if pressures greater than 552 kPa (80 psi) are anticipated, pressure relief measures are required. The maximum pressure at any point in the distribution system in unoccupied areas shall not exceed 689 kPa (100 psi). Under emergency fire flow conditions, the minimum pressure objective in the distribution system is 138 kPa (20 psi).



3.3.2 MODEL DEVELOPMENT

The proposed watermains within site were modeled in a H2OMAP hydraulic model to simulate the proposed water network. Hazen-Williams coefficients (“C-Factors”) were applied to the new watermain in accordance with the City of Ottawa’s Water Distribution Design Guidelines and as shown in **Table 3.3** below.

Table 3.3: Proposed Watermain C-Factors

Pipe Diameter (mm)	C-Factor
150	100
200 to 250	110
300 to 600	120
> 600	130

3.4 Hydraulic Model Results

The H2OMAP software was used to assess the proposed potable water network under average day, peak hour, and maximum day plus fire flow conditions using boundary conditions provided by City of Ottawa staff.

3.4.1 AVERAGE DAY DEMAND (AVDY)

Under average day demand, hydraulic modelling shows the anticipated pressure range to be 389 kPa to 437.3 kPa (56.4 psi to 63.4 psi) across the proposed site as shown in **Figure 3-1** below. This is well within the serviceable limit of 276 kPa to 552 kPa (40 psi to 80 psi) as specified in the City of Ottawa Water Design Guidelines.



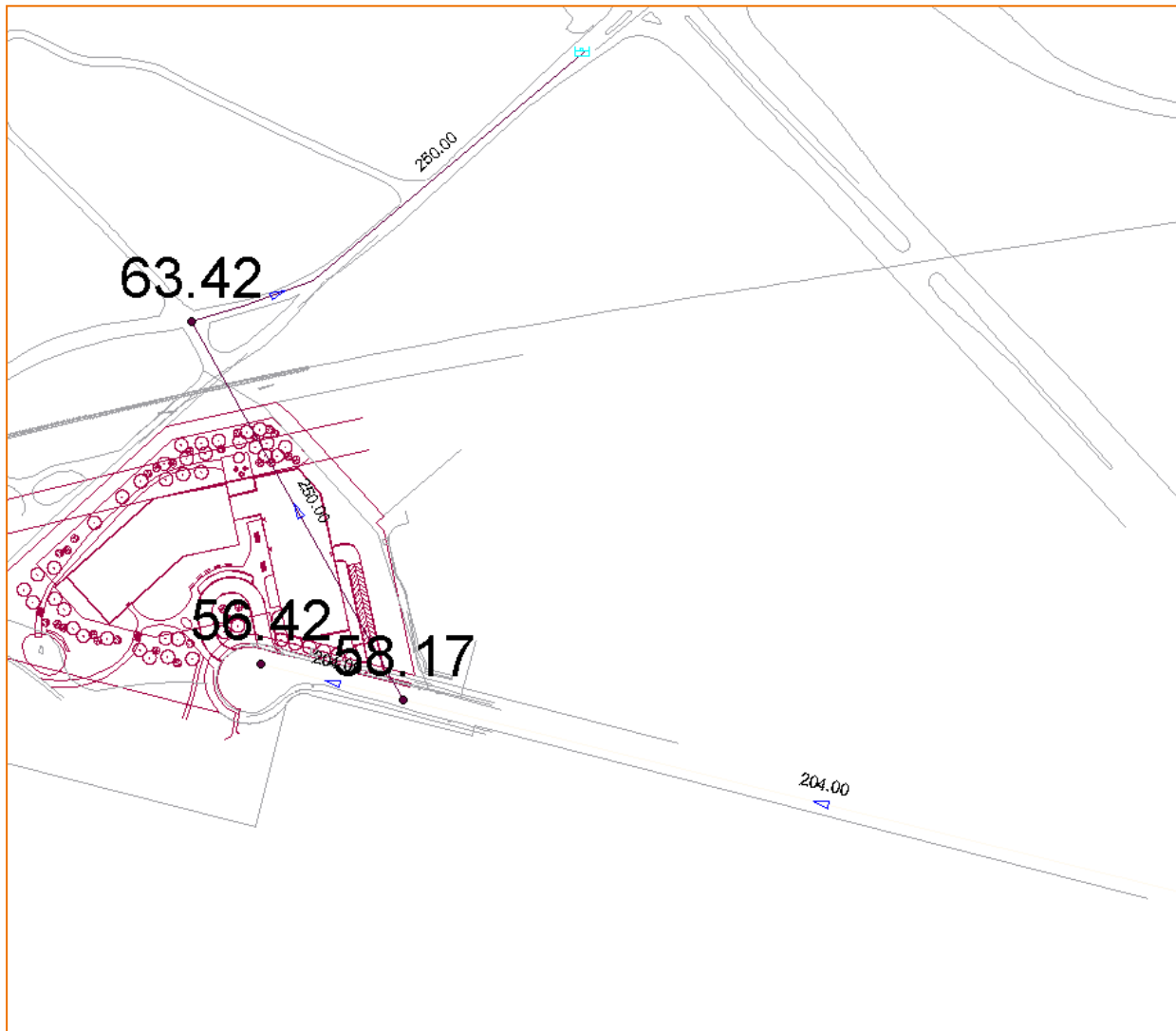

Figure 3-1: AVDY Pressure Results (psi)

3.4.2 PEAK HOUR DEMAND (PKHR)

Under peak hour demands, hydraulic modelling indicates that the anticipated pressures range from 349.4 kPa to 398.0 kPa (50.7 psi to 57.7 psi) across the proposed site as shown in **Figure 3-2** below. This is well within the serviceable limit of 276 kPa to 552 kPa (40 psi to 80 psi) as specified in the City of Ottawa Water Design Guidelines.

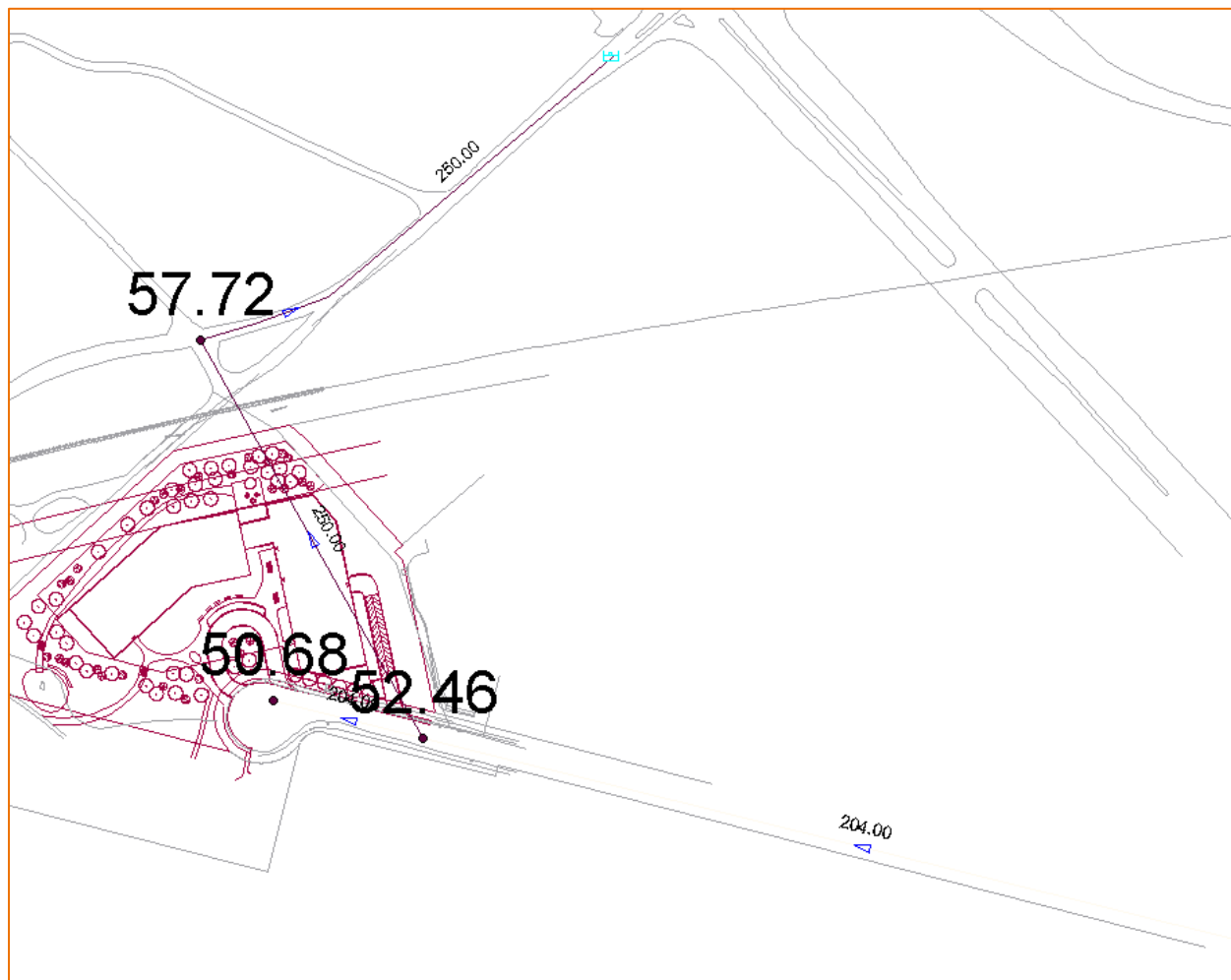

Figure 3-2: PKHR Pressure Results (psi)

3.4.3 MAXIMUM DAY DEMAND + FIRE FLOW (MXDY+FF)

The hydraulic modeling was also used to assess whether the proposed watermain could provide the maximum day and fire flow demand to the proposed development while maintaining a residual pressure of 138 kPa (20 psi) under the worst-case scenario, per the City of Ottawa Design Guidelines – Water Distribution. The modeling was carried out using a steady-state maximum day demand scenario along with the automated fire flow simulation feature of H2O Map.

Figure 3-3 illustrates that the proposed watermain can deliver fire flows in excess of 9,000 L/min (150 L/s), while maintaining the required residual pressure of 138 kPa (20 psi).



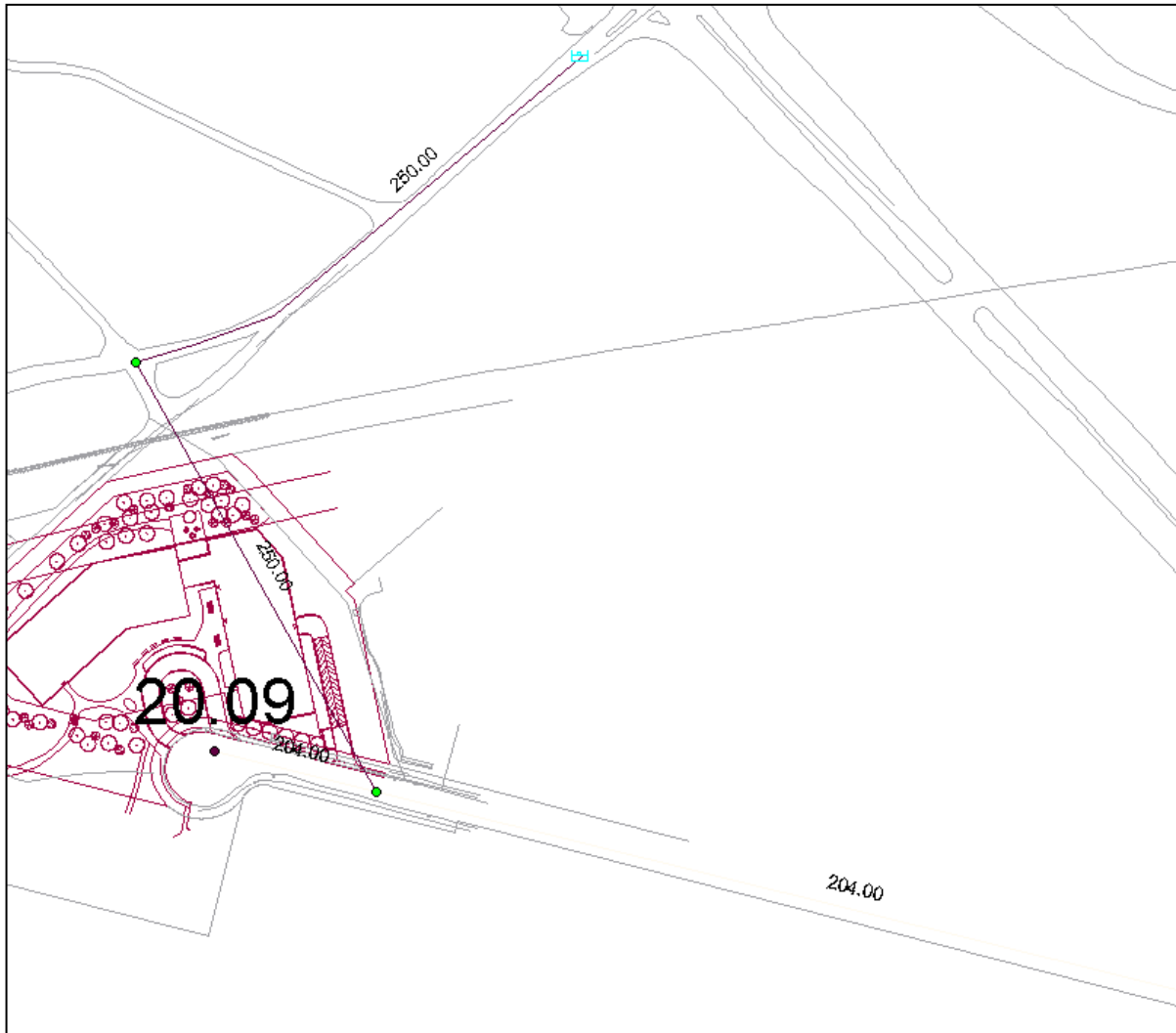

Figure 3-3: MXDY+FF Residual Pressures (psi)

3.5 Conclusion

Based on the findings of the report, sufficient fire flows are available within the proposed watermain network under emergency fire demand conditions (maximum day + fire flow) while meeting the minimum pressure requirements as per City of Ottawa standards.



4 Wastewater Servicing

4.1 Background

The site will be serviced via a short extension of the existing 250 mm diameter sanitary sewer within the Steacie Drive ROW at the southern boundary of the site (see **Drawing SSP-1**). It is proposed to connect to the existing sewer via a 200mm sanitary service line to service the proposed site.

4.2 Design Criteria

As outlined in the City of Ottawa Sewer Design Guidelines and the MECP's Design Guidelines for Sewage Works, the following criteria were used to calculate estimated wastewater flow rates and to determine the size and location of the sanitary service laterals:

- Minimum velocity = 0.6 m/s (0.8 m/s for upstream sections)
- Maximum velocity = 3.0 m/s
- Manning roughness coefficient for all smooth wall pipes = 0.013
- Minimum size of sanitary sewer service = 135 mm
- Minimum grade of sanitary sewer service = 1.0 % (2.0 % preferred)
- Average wastewater generation = 280 L/person/day (per City Design Guidelines)
- Peak Factor = based on Harmon Equation; maximum of 4.0 (residential)
- Harmon correction factor = 0.8
- Infiltration allowance = 0.33 L/s/ha (per City Design Guidelines)
- Minimum cover for sewer service connections = 2.0 m
- Average population density for apartment units – 1.8 persons/apartment

4.3 Wastewater Generation and Servicing Design

The estimated peak wastewater flow generated are based on the current site plan. The anticipated wastewater peak flow generated from the proposed development is summarized in **Table 4.1** below.

Table 4.1: Estimated Total Wastewater Peak Flow

Number of Units	Population	Peak Factor	Peak Flow (L/s)	Infiltration Flow (L/s)	Total Peak Flow (L/s)
214	385	3.42	4.3	0.7	5.0

1. Design residential flow based on 280 L/p/day.
2. Peak factor for residential units calculated using Harmon's formula.
3. Average population estimated based on 1.8 persons/unit for apartments units.
4. Infiltration design flow equals 0.33 L/s/ha.



Detailed sanitary sewage calculations are included in **Appendix B.1**. A full port backwater valve will be required for the proposed building in accordance with the Sewer Design Guidelines and will be coordinated with the building mechanical engineers.

4.4 Proposed Servicing

A 200 mm diameter sanitary building service is proposed to service the development. The lateral will connect via a monitoring manhole to the proposed 200 mm diameter on-site private sanitary sewers, which will connect in turn to the existing 250 mm diameter sanitary sewer on Steacie Drive. The proposed sanitary servicing is shown on **Drawings SSP-1** and **SA-1**.

A full port backwater valve Per City Std S14.1 will be installed on the proposed sanitary service within the site to prevent any surcharge from the downstream sewer main from impacting the proposed property. A sump pump will be required for sewage discharge from the mechanical room. Sizing of the service laterals, sump pit, sump pump, and design of the internal plumbing and associated mechanical systems are to be confirmed by the mechanical consultant.



5 Stormwater Management

5.1 Objectives

The goal of this stormwater servicing and stormwater management (SWM) plan is to determine the measures necessary to control the quantity and quality of stormwater released from the proposed development to meet the criteria established during the consultation process with City of Ottawa staff, and to provide sufficient details required for approval.

5.2 SWM Criteria and Constraints

The Stormwater Management (SWM) criteria were established by combining current design practices outlined by the City of Ottawa Sewer Design Guidelines (SDG, October 2012), review of project pre-consultation notes with the City of Ottawa, the functional level *Site Servicing and Stormwater Management Report* previously prepared for the subject lands, and through consultation with City of Ottawa staff. The following summarizes the criteria, with the source of each criterion indicated in brackets:

General

- Use of the dual drainage principle (City of Ottawa).
- Wherever feasible and practical, site-level measures should be used to reduce and control the volume and rate of runoff. (City of Ottawa)
- Assess impact of 100-year event outlined in the City of Ottawa Sewer Design Guidelines on major & minor drainage system (City of Ottawa)
- Enhanced quality control (80% TSS removal) to be provided on-site for the development (MVCA/Kizell Drain).

Storm Sewer & Inlet Controls

- Discharge for each storm event to be restricted to pre-development levels with a maximum runoff coefficient of $C=0.50$. (City of Ottawa pre-consultation)
- Peak flows generated from events greater than the 5-year and including the 100-year storm must be detained on site (City of Ottawa pre-consultation)
- The foundation drainage system is to be independently connected to sewer main unless being pumped with appropriate back up power, sufficient sized pump, and backflow prevention. (City of Ottawa pre-consultation)
- T_c should be not less than 10 minutes (City of Ottawa SDG).
- Size storm sewers to convey at minimum the 5-year storm event under free-flow conditions using City of Ottawa I-D-F parameters (City of Ottawa)
- 100-year storm HGL to be a minimum of 0.30 m below building foundation footing (City of Ottawa).

Surface Storage & Overland Flow



- Building openings to be minimum of 0.30 m above the 100-year water level (City of Ottawa)
- Maximum depth of flow under either static or dynamic conditions shall be less than 0.35 m in the 100-year event (City of Ottawa)
- Provide adequate emergency overflow conveyance off-site with a minimum vertical clearance of 15 cm between the spill elevation and the ground elevation at the building envelope in the proximity of the flow route or ponding area (City of Ottawa)

5.3 Existing Conditions

The existing site (2.25 ha) is vacant with thick trees and greenspace. An area measuring approximately 2.33 ha corresponding to lands within the site for development and upstream offsite tributary areas have been used for determining the pre-development target release rate. Available topographic information for the site, of which the existing drainage conditions and grading for the site are derived from, are shown in **Drawing EX-1**.

Four sub-catchments were delineated in **Drawing EX-1** based on the existing topographic grading and outlets. As the existing site is undeveloped, the overall pre-development runoff coefficient was established to be C=0.20, below the maximum pre-development runoff coefficient of C=0.50 identified in consultation with City of Ottawa staff and summarized in **Table 5.1** below.

Table 5.1: Summary of Existing Subcatchment Areas

Catchment Areas	C	A (ha)	Outlet
EX-1	0.20	1.18	Ditch along rail line (West)
EX-2	0.20	0.11	Steacie ROW
EX-3	0.20	0.46	Ditch along rail line (North) via adjacent property
EX-4	0.20	0.58	Ditch along rail line (North)
Total	0.20	2.33	-

Note that area EX-1 includes upstream off-site tributary areas within the adjacent park land. Areas not proposed for development (Areas UNC-2 through UNC-4 as shown on **Drawing SD-1**) will continue to discharge overland on their existing drainage path. Area UNC-1 will continue to discharge uncontrolled to the Steacie Drive ROW, and represents a marginal increase in runoff to the existing Steacie Drive roadside ditch.

The pre-development release rates for the site have been determined using the rational method and drainage characteristics identified above. A time of concentration for the predevelopment area (10 minutes) was assigned based on the relatively small site and its proximity to the existing drainage outlet for the site. C coefficient values have been increased by 25 % for the post-development 100-year storm event based on MTO Drainage Manual recommendations. Peak flow rates have been calculated using the rational method as follows:

$$Q = 2.78 C_i A$$



Where: Q = peak flow rate, L/s

A = drainage area, ha

I = rainfall intensity, mm/hr (per Ottawa IDF curves)

C = site runoff coefficient

The target release rate for the site is summarized in **Table 5.2** below:

Table 5.2: Target Release Rate

Design Storm	Target Flow Rate (L/s)
5-Year	135.1
100-Year	289.3

5.4 Stormwater Management Design

The proposed building will be serviced by a 250 mm diameter storm service lateral connected to a storm sewer network within the private driveways, which will collect stormwater discharge to a proposed stormwater dry pond, which ultimately discharges to the existing ditches along the north side of the existing rail corridor. The site has been subdivided into catchment areas to effectively collect, store, and convey runoff flowrates not exceeding the target release rate established in sections above.

Discharge from the building's rooftop, foundation drains, trench drain, and area drains are to be routed to the 250 mm diameter storm service lateral via the building's internal plumbing, which is to be designed by the mechanical consultant. On site catch basin(s) will collect additional drainage on site to the storm sewers for conveyance to the dry pond.

The proposed site plan, drainage areas and proposed storm sewer infrastructure are shown on **Drawing SD-1 and SSP-1**.

5.4.1 QUANTITY CONTROL: STORAGE REQUIREMENTS

The Modified Rational Method (MRM) was used to assess the flow rate and volume of runoff generated under post-development conditions. The site was subdivided into sub-catchments tributary to separate drainage outlets with most directed towards the dry pond. **Drawing SD-1** shows the delineated sub-catchment areas, while the MRM spreadsheet is included in **Appendix C.2**.

The following assumptions were made in the creation of the storm drainage plot and accompanying MRM spreadsheet:

- Excess run-off that cannot be captured as surface storage due to grading constraints is to sheet flow uncontrolled per existing conditions (areas UNC-1 to UNC-4).
- Area OFF-1 encompasses off-site runoff from the adjacent park which flows through the subject site. Area OFF-1 is tributary to the proposed dry pond and has been included in the overall pond discharge rate.



Site Servicing and Stormwater Management Report - 100 Steacie Drive

- An inlet control device (ICD) at the dry pond outlet manhole will be used to manage stormwater flows from the site.
- Restricted roof drains will be used to manage stormwater flows from the rooftop.

5.4.1.1 Rooftop Storage

It is proposed to retain stormwater on the building rooftop to a maximum depth of 0.15 m by installing restricted flow roof drains and overflow scuppers. The MRM calculations assume the roof will be equipped with 16 standard Watts model roof drains complete with Adjustable Accutrol Weirs. Discharge from the 16 controlled roof drains will be routed by the mechanical consultant through the building's internal plumbing to the storm service lateral.

Watts Drainage "Accutrol" roof drain weir data has been used to calculate a practical roof release rate and detention storage volume for the rooftops. It should be noted that the "Accutrol" weir has been used as an example only, and that other products may be specified for use, provided that the total roof drain release rate is restricted to match the maximum rate of release indicated in **Table 5.3**, and that sufficient roof storage is provided to meet (or exceed) the resulting volume of detained stormwater. Storage volume and controlled release rate are summarized in **Table 5.3**:

Table 5.3: 100 Year Summary of Roof Controls

Area ID	Depth (mm)	Discharge (L/s)	Volume Stored (m ³)	Storage Provided (m ³)
R4A	148	21.6	171.3	177.2

*Drainage from the roof is anticipated to enter the dry pond at the western boundary of the site.

5.4.1.2 Surface Storage

As part of the stormwater management design of the site development, a stormwater management dry pond is proposed to attenuate peak flows from the site. Per the modified rational method calculations included as part of **Appendix C.2**, discharge from site are to be directed towards the proposed storm sewers on site, which ultimately conveys discharge to the dry pond. The volume of storage proposed is sufficient to retain the stormwater generated by each storm event while not exceeding the allowable release rate. A large portion of the stormwater on the site (excluding some uncontrolled flows) will be directed towards the dry pond and ultimately discharge to Kizell Creek.

The MRM sheet provided in **Appendix C.2** demonstrates that a volume of 94.6 m³ of storage is required. Based on the proposed site plan, dry pond storage is available to provide the necessary storage within the site.

Controlled release rates and storage volumes required are summarized in **Table 5.4**.



Table 5.4: Surface Storage Areas - 100 Year Event

Tributary Area	Design Storm	Design Head (m)	Discharge (L/s)	Orifice Type	V _{required} (m ³)	V _{provided} (m ³)
POND-1, C500A, C501A, C502A, OFF-1	100-Year	0.90 (elevation 86.40)	80.5	200 mm	91.7	425.0

The proposed stormwater management pond is equipped with a 1.0 m wide spillway at elevation 87.40 to ensure that if the quantity control orifice is blocked, the pond may still safely discharge without impacting upstream USF elevations. As the proposed pond is oversized to meet storage requirements of the 100-year storm event, spillway use is not anticipated for design storm events up to and including the 100-year storm event.

5.4.1.3 Uncontrolled Areas

Uncontrolled areas represent drainage areas that cannot be graded to enter the storm sewer system due to grading restrictions. As such, they will sheet drain off the site to adjacent outlets per existing conditions.

Table 5.5: Peak Post-Development Uncontrolled Surface Release Rates

Design Storm	Release Rate (L/s)				
	UNC-1	UNC-2	UNC-3	UNC-4	Total
5-Year	10.0	12.1	10.2	32.4	64.7
100-Year	21.4	25.9	21.9	69.4	138.7

Table 5.6 compares the pre- and post-development peak stormwater release rates from site areas to the existing outlets per existing conditions. The table below demonstrates that by developing the site, the overall stormwater release rate from the site will be reduced by as compared to existing conditions.



Table 5.6: Comparison of Discharge Pre- to Post-Development

Outlet		A (ha)	C	5-Year (L/s)	5-Year Difference (L/s)	100-Year (L/s)	100-Year Difference (L/s)
Ditch along rail line (West)	Pre-	1.18	0.20	68.4	-	146.4	-
	Post-	1.88	0.45	91.2	22.8	149.9	3.5
Steacie Drive ROW	Pre-	0.11	0.20	6.4	-	13.7	-
	Post-	0.09	0.40	10.0	3.6	21.4	7.7
Ditch along rail line (North) via Adjacent property	Pre-	0.46	0.20	26.6	-	57.1	-
	Post-	0.19	0.22	12.1	-14.5	25.9	-31.2
Ditch along rail line (North)	Pre-	0.58	0.20	33.6	-	72.0	-
	Post-	0.18	0.20	10.2	-23.4	21.9	-50.1
Difference		0.00	-	-	-11.5	-	-70.1

The reverse sloped ramp to the parking garage is to be equipped with a trench drain at the bottom of the ramp to provide an outlet for the driveway area (C502A subcatchment) with connection to the building storm service.

5.4.2 RESULTS

Table 5.7 identifies the release rates associated with the proposed stormwater management plan and demonstrates adherence to target peak outflow rates of the site.

Table 5.7: Summary 5-Year and 100-Year Event Release Rates

	Peak Discharge (L/s)	
	5-Year (L/s)	100-Year (L/s)
Total to Railway Ditch	113.5	197.7
Total to Steacie Drive ROW	10.0	21.4
Total	123.5	219.1
Target	135.1	289.3

5.4.3 QUALITY CONTROL

On-site quality control measures are expected for the proposed development per pre-consultation with MVCA and City of Ottawa staff. It is assumed that enhanced protection (80 % removal of total suspended solids) will be required for the site before discharging to the Kizell Creek. As a result, an oil grit separator (OGS) has been proposed to treat runoff from impervious areas directed to the proposed dry pond.

The OGS unit will be privately maintained and located upstream of the dry pond as shown on **Drawing SD-1**. Using a fine particle size distribution and the Stormceptor Sizing Tool, a Stormceptor model EF06 has been selected for the proposed inlet manhole at the dry pond and will achieve 88 % TSS removal,



exceeding the minimum required level of 80 %. The surface areas and runoff coefficient in which the sizing is based on is tabulated in **Table 5.8** below, while the detailed Stormceptor sizing report is included in **Appendix C.3**.

Table 5.8: Surface Area and Runoff for Stormceptor Sizing

Catchment Areas	A (ha)	C
R4A	0.45	0.90
C500A	0.13	0.58
C501A	0.16	0.33
C502A	0.05	0.65
POND-1	0.46	0.35
Total	1.24	0.58

The proposed OGS (Stormceptor) unit has been considered as an example only. Other OGS products or treatment systems with equivalent TSS removal capabilities may also be selected based on the input parameters noted within the Stormceptor sizing report.



6 Grading and Drainage

The proposed development site measures approximately 2.2 ha in area. The topography across the site is sloped with higher elevations near the southern boundary draining towards Kizell Creek located at the southwestern boundary of the site.

Detailed grading plans (see **Drawing GP-1, GP-2**) has been provided to satisfy the stormwater management requirements, adhere to any geotechnical restrictions for the site, and provide for minimum cover requirements for storm and sanitary sewers where possible. Site grading has been established to provide emergency overland flow routes required for stormwater management in accordance with City of Ottawa requirements.

The subject site maintains emergency overland flow routes for flows deriving from storm events in excess of the maximum design event to Kizell Creek as depicted in **Drawing GP-1**.

7 Utilities

Bell, Hydro and Rogers services exist in the vicinity of the proposed site. The site will be serviced through connection to these existing services.

As per our conversation with Enbridge, they have a plant within the vicinity of the site and will likely have sufficient capacity. However, only after receiving the detail loading criteria, will they be able to provide their final design.

Detailed design of the required utility services will be completed by the respective utility companies.

Hydro, Bell, Gas and Cable servicing for the proposed development should be readily available within subsurface utility infrastructure within the Steacie Drive ROW. Exact size, location and routing of utilities, along with determination of any off-site works required for redevelopment, will be finalized after design circulation.

8 Approvals

The proposed stormwater works comprises of a dry pond that ultimately discharges to Kizell Creek. As the site is of a single parcel under singular ownership, The site will not require an Environmental Compliance Approval (ECA) from the Ministry of the Environment, Conservation and Parks (MECP) under O.Reg. 525/98 for stormwater management works. An ECA will be required for municipally operated sanitary sewer works within the Steacie Drive ROW, to be processed under CLI-ECA for pre-approved works.

Requirement for a MECP Permit to Take Water (PTTW) for pumping during construction of the underground parking levels will be confirmed by the geotechnical consultant.



9 Erosion Control During Construction

To protect downstream water quality and prevent sediment build-up in catch basins and storm sewers, erosion and sediment control measures must be implemented during construction. The following recommendations will be included in the contract documents and communicated to the Contractor.

1. Implement best management practices to provide appropriate protection of the existing and proposed drainage system and the receiving water course(s).
2. Limit the extent of the exposed soils at any given time.
3. Re-vegetate exposed areas as soon as possible.
4. Minimize the area to be cleared and grubbed.
5. Protect exposed slopes with geotextiles, geogrid, or synthetic mulches.
6. Install silt barriers/fencing around the perimeter of the site as indicated in **Drawing ECDS-1** to prevent the migration of sediment offsite.
7. Install trackout control mats (mud mats) at the entrance/egress to prevent migration of sediment into the public ROW.
8. Provide sediment traps and basins during dewatering works.
9. Install sediment traps (such as SiltSack® by Terrafix) between catch basins and frames.
10. Schedule the construction works at times which avoid flooding due to seasonal rains.

The Contractor will also be required to complete inspections and guarantee the proper performance of their erosion and sediment control measures at least after every rainfall. The inspections are to include:

- Verification that water is not flowing under silt barriers.
- Cleaning and changing the sediment traps placed on catch basins.

Refer to **Drawing ECDS-1** for the proposed location of silt fences, sediment traps, and other erosion control measures.

10 Geotechnical Investigation

A geotechnical investigation was conducted by Morey Houle Chevrier Engineering Ltd. in May 2005. Subsurface soil conditions within the boundaries of the proposed site were determined by 16 boreholes distributed across the site. The subsurface profile across the site described by the previous investigation consists of surficial fill material made up by topsoil composed of silty sand, underlain by silty clay with glacial till encountered at some locations.

Bedrock elevations vary from 0.9 m to 5.4 m below existing ground surface. Groundwater elevations at the time were encountered from 0.2 m to 0.6 m. An updated geotechnical investigation is recommended to obtain accurate results based on current conditions.



11 Conclusions

11.1 Water Servicing

Based on the boundary conditions provided by the City of Ottawa, the adjacent watermains on Steacie Drive and Station Road can provide adequate flow and pressure to service the development. Pressure across the distribution system meets the pressure range as per the City of Ottawa Water Design guidelines under typical demand conditions (Average Day and Peak Hour).

The results also indicate that sufficient fire flows are available within the proposed watermain network under emergency fire demand conditions (maximum day + fire flow) while meeting the minimum requirements as per the City of Ottawa Water Design guidelines.

11.2 Sanitary Servicing

The proposed sanitary sewer service will consist of a sanitary service lateral, a 200 mm diameter sanitary sewer, a sanitary sump pit, monitoring ports, and sump pump(s) directing wastewater to the existing 250 mm diameter sanitary sewer on Steacie Drive. Full port backwater valves will be installed on the proposed sanitary service within the site to prevent any surcharge from the downstream sewer main from impacting the proposed property. A sump pump will be required for sewage discharge from the mechanical room. Sizing of the service lateral, sump pit, and sump pump are to be confirmed by the mechanical consultant.

11.3 Stormwater Servicing

Rooftop storage and a stormwater dry pond has been proposed to limit the stormwater discharge rates to the pre-development levels. The uncontrolled site areas continue to drain uncontrolled to the existing outlets, adjacent properties, and the Steacie Drive ROW as per existing conditions.

A 250 mm diameter storm service lateral is proposed for the building's foundation, roof drain, and internal storm drainage plumbing system, which will receive drainage from the area drains on site, and will be equipped with a full port backwater valve. The on-site storm sewer conveys discharge from the building and the immediate areas to a proposed dry pond, which will be equipped with an inlet control device at the outlet for quantity control and outlet to the existing northern ditch within the existing rail corridor. Sizing of the service lateral, foundation, and area drains are to be confirmed by the mechanical consultant. Flood plain mapping provided by the MVCA for Kizell Creek has been incorporated in the site design.

11.4 Grading

Grading for the site has been designed to provide an emergency overland flow route as per City requirements and reflects the recommendations in the Geotechnical Investigation Report prepared by



Site Servicing and Stormwater Management Report - 100 Steacie Drive

11 Conclusions

Houle Chevrier Engineering Ltd. Erosion and sediment control measures will be implemented during construction to reduce the impact on existing facilities.

11.5 Utilities

Utility infrastructure exists within the Steacie Drive ROW at the southern boundary of the proposed site. It is anticipated that existing infrastructure will be sufficient to provide a means of distribution for the proposed site. Exact size, location and routing of utilities will be finalized after design circulation.

11.6 Approvals/Permits

The site will be subjected to Ministry of the Environment, Conservation and Parks (MECP) Environmental Compliance Approval (ECA) process under O.Reg. 525/98 for sanitary sewer works within Steacie Drive. Requirement for a MECP Permit to Take Water (PTTW) for sewer and building construction will be confirmed by the geotechnical consultant.



APPENDICES



Appendix A Water Servicing

A.1 Water Demands



Domestic Water Demand Estimates - 100 Steacie Drive

Site Plan provided by Neuf dated 2024-02-16

Project No. 160401570

Population densities as per Table 4.1 of the City of Ottawa Water Design Guidelines:		
Apartments	1.8	ppu



Unit Type	Units	Population	Daily Rate of Demand (L/cap/day) ²	Avg Day Demand		Max Day Demand ¹		Peak Hour Demand ¹	
				(L/min)	(L/s)	(L/min)	(L/s)	(L/min)	(L/s)
Apartment	214	385	280	74.9	1.25	187.3	3.12	412.0	6.87
Total Site :	214	385	-	74.9	1.25	187.3	3.12	412.0	6.87

Notes:

1 Water demand criteria used to estimate peak demand rates for residential areas are as follows:

maximum day demand rate = 2.5 × average day demand rate

peak hour demand rate = 2.2 × maximum day demand rate (as per Technical Bulletin ISD-2010-02)

2 As per Table 4.2 from the City of Ottawa Water Design Guidelines and Technical Bulletin ISTB-2021-03, the average daily rate of water demand for residential areas: 280 L/cap/day

A.2 FUS Fire Flow Calculations





FUS Fire Flow Calculation Sheet - 2020 FUS Guidelines

Stantec Project #: 160401570
 Project Name: 100 Steacie Drive
 Date: 2024-04-03

Fire Flow Calculation #: 1
 Description: 4-storey residential apartment

Notes: Site Plan and Design Brief provided by Neuf on 2024-02-16. OBC Section 3.2.2.48A Group C Sprinklered

Step	Task	Notes	Value Used	Req'd Fire Flow (L/min)						
1	Determine Type of Construction	Type II - Noncombustible Construction / Type IV-A - Mass Timber Construction	0.8	-						
2	Determine Effective Floor Area	Sum of Two Largest Floors + 50% of Eight Additional Floors	Vertical Openings Protected?	NO	-					
		4494 4494 4494 4494		13482	-					
3	Determine Required Fire Flow	(F = 220 x C x A ^{1/2}). Round to nearest 1000 L/min	-	20000						
4	Determine Occupancy Charge	Limited Combustible	-15%	17000						
5	Determine Sprinkler Reduction	Conforms to NFPA 13	-30%	-8500						
		Standard Water Supply	-10%							
		Fully Supervised	-10%							
		% Coverage of Sprinkler System	100%							
6	Determine Increase for Exposures (Max. 75%)	Direction	Exposure Distance (m)	Exposed Length (m)	Exposed Height (Stories)	Length-Height Factor (m x stories)	Construction of Adjacent Wall	Firewall / Sprinklered ?	-	-
		North	> 30	0	0	0-20	Type V	NO	0%	0
		East	> 30	0	0	0-20	Type V	NO	0%	
		South	> 30	0	0	0-20	Type V	NO	0%	
		West	> 30	0	0	0-20	Type V	NO	0%	
7	Determine Final Required Fire Flow	Total Required Fire Flow in L/min, Rounded to Nearest 1000L/min							9000	
		Total Required Fire Flow in L/s							150.0	
		Required Duration of Fire Flow (hrs)							2.00	
		Required Volume of Fire Flow (m ³)							1080	

A.3 Boundary Conditions



Boundary Conditions 100 Steacie Drive

Provided Information

Scenario	Demand	
	L/min	L/s
Average Daily Demand	143	2.38
Maximum Daily Demand	357	5.95
Peak Hour	786	13.10
Fire Flow Demand #1	11,000	183.33

Location



Results

Connection 1 – Steacie Dr.

Demand Scenario	Head (m)	Pressure ¹ (psi)
Maximum HGL	131.3	62.6
Peak Hour	127.4	57.0
Max Day plus Fire 1	118.9	45.0

¹ Ground Elevation = 87.2 m

Connection 2 – Station Rd.

Demand Scenario	Head (m)	Pressure ¹ (psi)
Maximum HGL	131.2	69.0
Peak Hour	127.2	63.3
Max Day plus Fire 1	123.3	57.7

¹ Ground Elevation = 82.7m

Disclaimer

The boundary condition information is based on current operation of the city water distribution system. The computer model simulation is based on the best information available at the time. The operation of the water distribution system can change on a regular basis, resulting in a variation in boundary conditions. The physical properties of watermains deteriorate over time, as such must be assumed in the absence of actual field test data. The variation in physical watermain properties can therefore alter the results of the computer model simulation. Fire Flow analysis is a reflection of available flow in the watermain; there may be additional restrictions that occur between the watermain and the hydrant that the model cannot take into account.

A.4 H2OMap Hydraulic Analysis Results



EXISTING CONDITIONS

Hydraulic Model Results - Average Day Analysis

Junction Results

ID	Demand	Elevation	Head	Pressure	
	(L/s)	(m)	(m)	(psi)	(Kpa)
10	0.00	86.60	131.21	63.42	437.27
14	1.25	91.53	131.22	56.42	389.00
16	0.00	90.30	131.22	58.17	401.07

Pipe Results

ID	From Node	To Node	Length	Diameter	Roughness	Flow	Velocity
			(m)	(mm)		(L/s)	(m/s)
42	14	16	64.31	204	110	-1.25	0.04
44	10000	10	220.00	250	110	-3.86	0.08
46	10	16	193.00	250	110	-3.86	0.08
48	16	10001	339.69	204	110	-5.11	0.16

Hydraulic Model Results -Peak Hour Analysis

Junction Results

ID	Demand	Elevation	Head	Pressure	
	(L/s)	(m)	(m)	(psi)	(Kpa)
10	0.00	86.60	127.20	57.72	397.97
14	6.87	91.53	127.18	50.68	349.43
16	0.00	90.30	127.20	52.46	361.70

Pipe Results

ID	From Node	To Node	Length	Diameter	Roughness	Flow	Velocity
			(m)	(mm)		(L/s)	(m/s)
42	14	16	64.31	204	110	-6.87	0.21
44	10000	10	220.00	250	110	-1.49	0.03
46	10	16	193.00	250	110	-1.49	0.03
48	16	10001	339.69	204	110	-8.36	0.26

Hydraulic Model Results -Fire Flow Analysis 150 L/s

ID	Static Demand	Static Pressure		Static Head	Fire-Flow Demand	Residual Pressure		Available Flow at Hydrant	Available Flow Pressure	
	(L/s)	(psi)	(Kpa)	(m)	(L/s)	(psi)	(Kpa)	(L/s)	(psi)	(Kpa)
14	3.12	43	296.48	121.77	150	20.09	138.52	153.44	20	137.90

Appendix B Sanitary Servicing

B.1 Sanitary Design Sheet



Appendix C Stormwater Servicing and Management

C.1 Storm Sewer Design Sheet





100 Steacie Drive

STORM SEWER DESIGN SHEET (City of Ottawa)

DESIGN PARAMETERS

I = a / (t+b)^2 (As per City of Ottawa Guidelines, 2012)

Table with 4 columns: 1.2 yr, 1.5 yr, 1.10 yr, 1.100 yr. Rows for a, b, c values.

MANNING'S n = 0.013, BEDDING CLASS = B, MINIMUM COVER: 2.00 m, TIME OF ENTRY: 10 min

DATE: 2024-07-30, REVISION: 1, DESIGNED BY: MW, CHECKED BY:

FILE NUMBER: 160401570

Main data table with columns: LOCATION, DRAINAGE AREA, PIPE SELECTION, and various flow/velocity metrics. Includes rows for R4A, C501A, C500A, C502A, POND-1, and HDWL/OUTLET.

C.2 MRM Analysis



Stormwater Management Calculations

File No: 160401570
 Project: 100 Steacie Drive
 Date: 31-Jul-24

SWM Approach:
 Post-development to Pre-development flows

Post-Development Site Conditions:

Overall Runoff Coefficient for Site and Sub-Catchment Areas

Runoff Coefficient Table								
Sub-catchment Area	ID / Description	Area (ha) "A"	Runoff Coefficient "C"	"A x C"	Overall Runoff Coefficient			
Catchment Type								
External - Tributary	OFF-1	Hard	0.000	0.9	0.000			
		Soft	0.086	0.2	0.017			
	Subtotal			0.09		0.0172318	0.200	
Roof	R4A	Hard	0.443	0.9	0.399			
		Soft	0.000	0.2	0.000			
	Subtotal			0.44		0.3986091	0.900	
Uncontrolled - Tributary to Pond	POND-1	Hard	0.098	0.9	0.088			
		Soft	0.360	0.2	0.072			
	Subtotal			0.46		0.1603249	0.350	
Uncontrolled - Tributary to Pond	C502A	Hard	0.032	0.9	0.029			
		Soft	0.018	0.2	0.004			
	Subtotal			0.05		0.0325676	0.650	
Controlled - Tributary to Pond	C501A	Hard	0.015	0.9	0.014			
		Soft	0.139	0.2	0.028			
	Subtotal			0.15		0.0418387	0.270	
Controlled - Tributary to Pond	C500A	Hard	0.069	0.9	0.062			
		Soft	0.058	0.2	0.012			
	Subtotal			0.13		0.0737859	0.580	
Uncontrolled - Towards Ditch (West)	UNC-4	Hard	0.000	0.9	0.000			
		Soft	0.559	0.2	0.112			
	Subtotal			0.56		0.111769	0.200	
Uncontrolled - Towards Ditch (North)	UNC-3	Hard	0.000	0.9	0.000			
		Soft	0.177	0.2	0.035			
	Subtotal			0.18		0.035359	0.200	
Uncontrolled - Towards Adjacent Property	UNC-2	Hard	0.005	0.9	0.005			
		Soft	0.184	0.2	0.037			
	Subtotal			0.19		0.0417776	0.220	
Uncontrolled - Towards Steacie ROW	UNC-1	Hard	0.025	0.9	0.022			
		Soft	0.062	0.2	0.012			
	Subtotal			0.09		0.0345464	0.400	
Total				2.331		0.948	0.41	

Overall Runoff Coefficient= C:

Total Roof Areas	0.443 ha
Total Tributary Surface Areas (Controlled and Uncontrolled)	0.877 ha
Total Tributary Area to Outlet	1.319 ha
 Total Uncontrolled Areas (Non-Tributary)	 1.012 ha
 Total Site	 2.331 ha

Stormwater Management Calculations

Project #160401570, 100 Steacie Drive Modified Rational Method Calculations for Storage

5 yr Intensity City of Ottawa	I = a/(t + b)	a = 998.071	t (min)	I (mm/hr)
		b = 6.053	10	104.19
	c = 0.814	20	70.25	
		30	53.93	
		40	44.18	
		50	37.65	
		60	32.94	
		70	29.37	
		80	26.56	
		90	24.29	
		100	22.41	
		110	20.82	
		120	19.47	

5 YEAR Predevelopment Target Release from Portion of Site

Subdrainage Area: Predevelopment Tributary Area to Outlet
 Area (ha): 2.33
 C: 0.20

Typical Time of Concentration

tc (min)	I (5 yr) (mm/hr)	Qtarget (L/s)
10	104.2	135.1

5 YEAR Modified Rational Method for Entire Site

Subdrainage Area: POND Pond

tc (min)	I (5 yr) (mm/hr)	Qactual (L/s)	Qrelease (L/s)	Qstored (L/s)	Vstored (m³)
10	104.2	113.0	58.8	54.2	32.5
20	70.3	82.7	58.8	23.9	28.6
30	53.9	68.0	58.8	9.2	16.5
40	44.2	59.1	58.8	0.3	0.7
50	37.7	53.1	53.1	0.0	0.0
60	32.9	48.7	48.7	0.0	0.0
70	29.4	45.2	45.2	0.0	0.0
80	26.6	42.5	42.5	0.0	0.0
90	24.3	40.2	40.2	0.0	0.0
100	22.4	38.2	38.2	0.0	0.0
110	20.8	36.4	36.4	0.0	0.0
120	19.5	34.9	34.9	0.0	0.0

Storage: Above CB

Orifice Equation: $Q = CdA(2gh)^{0.5}$ Where C = 0.61

Orifice Diameter: 200 mm
 Orifice CL Elevation: 85.50 m
 Spill Elevation: 87.40 m
 Max Ponding Depth: 0.48 m
 Downstream W/L: 85.40 m

Stage (m)	Head (m)	Discharge (L/s)	Vreq (cu. m)	Vavail (cu. m)	Volume Check
5-year Water Level	85.98	0.48	58.8	32.5	33.8 OK

Subdrainage Area: OFF-1 External - Tributary
 Area (ha): 0.09
 C: 0.20

tc (min)	I (5 yr) (mm/hr)	Qactual (L/s)	Qrelease (L/s)	Qstored (L/s)	Vstored (m³)
10	104.2	5.0			
20	70.3	3.4			
30	53.9	2.6			
40	44.2	2.1			
50	37.7	1.8			
60	32.9	1.6			
70	29.4	1.4			
80	26.6	1.3			
90	24.3	1.2			
100	22.4	1.1			
110	20.8	1.0			
120	19.5	0.9			

Subdrainage Area: R4A Roof
 Area (ha): 0.44 Maximum Storage Depth: 150 mm
 C: 0.90

tc (min)	I (5 yr) (mm/hr)	Qactual (L/s)	Qrelease (L/s)	Qstored (L/s)	Vstored (m³)	Depth (mm)
10	104.2	115.5	18.6	96.8	58.1	102.8
20	70.3	77.8	19.0	58.8	70.6	109.0
30	53.9	59.8	19.1	40.6	73.1	110.3
40	44.2	49.0	19.1	29.9	71.7	109.6
50	37.7	41.7	19.0	22.8	68.3	107.9
60	32.9	36.5	18.8	17.7	63.7	105.6
70	29.4	32.5	18.6	13.9	58.4	102.9
80	26.6	29.4	18.5	11.0	52.7	100.1
90	24.3	26.9	18.2	8.7	47.2	95.7
100	22.4	24.8	17.9	7.0	41.8	91.2
110	20.8	23.1	17.6	5.5	36.3	86.7
120	19.5	21.6	17.3	4.3	30.9	82.2

Storage: Roof Storage

Depth (mm)	Head (m)	Discharge (L/s)	Vreq (cu. m)	Vavail (cu. m)	Discharge Check
5-year Water Level	110.3	0.11	19.1	73.1	177.2 0.00

Project #160401570, 100 Steacie Drive Modified Rational Method Calculations for Storage

100 yr Intensity City of Ottawa	I = a/(t + b)	a = 1735.688	t (min)	I (mm/hr)
		b = 6.014	10	178.56
	c = 0.820	20	119.95	
		30	91.87	
		40	75.15	
		50	63.95	
		60	55.89	
		70	49.79	
		80	44.99	
		90	41.11	
		100	37.90	
		110	35.20	
		120	32.89	

100 YEAR Predevelopment Target Release from Portion of Site

Subdrainage Area: Predevelopment Tributary Area to Outlet
 Area (ha): 2.33
 C: 0.25

Estimated Time of Concentration after Development

tc (min)	I (100 yr) (mm/hr)	Q100yr (L/s)
10	178.6	289.3

100 YEAR Modified Rational Method for Entire Site

Subdrainage Area: POND Pond

tc (min)	I (100 yr) (mm/hr)	Qactual (L/s)	Qrelease (L/s)	Qstored (L/s)	Vstored (m³)
10	178.6	222.6	80.5	142.1	85.2
20	120.0	157.0	80.5	76.5	91.7
30	91.9	125.5	80.5	45.0	80.9
40	75.1	106.7	80.5	26.1	62.7
50	64.0	94.0	80.5	13.5	40.5
60	55.9	84.9	80.5	4.3	15.6
70	49.8	77.9	77.9	0.0	0.0
80	45.0	72.4	72.4	0.0	0.0
90	41.1	67.9	67.9	0.0	0.0
100	37.9	64.1	64.1	0.0	0.0
110	35.2	60.9	60.9	0.0	0.0
120	32.9	58.2	58.2	0.0	0.0

Storage: Surface Storage Above CB

Orifice Equation: $Q = CdA(2gh)^{0.5}$ Where C = 0.61

Orifice Diameter: 200 mm
 Orifice CL Elevation: 85.50 m
 Spill Elevation: 87.40 m
 Max Ponding Depth: 0.90 m
 Downstream W/L: 85.40 m

Stage (m)	Head (m)	Discharge (L/s)	Vreq (cu. m)	Vavail (cu. m)	Volume Check
100-year Water Level	86.40	0.90	80.5	91.7	92.3 OK

Subdrainage Area: OFF-1 External - Tributary
 Area (ha): 0.09
 C: 0.25

tc (min)	I (100 yr) (mm/hr)	Qactual (L/s)	Qrelease (L/s)	Qstored (L/s)	Vstored (m³)
10	178.6	10.7			
20	120.0	7.2			
30	91.9	5.5			
40	75.1	4.5			
50	64.0	3.8			
60	55.9	3.3			
70	49.8	3.0			
80	45.0	2.7			
90	41.1	2.5			
100	37.9	2.3			
110	35.2	2.1			
120	32.9	2.0			

Subdrainage Area: R4A Roof
 Area (ha): 0.44 Maximum Storage Depth: 150 mm
 C: 1.00

tc (min)	I (100 yr) (mm/hr)	Qactual (L/s)	Qrelease (L/s)	Qstored (L/s)	Vstored (m³)	Depth (mm)
10	178.6	219.9	20.5	199.4	119.6	130.7
20	120.0	147.7	21.2	126.5	151.8	141.5
30	91.9	113.1	21.5	91.6	164.9	145.9
40	75.1	92.5	21.6	70.9	170.2	147.7
50	64.0	78.7	21.6	57.1	171.3	148.0
60	55.9	68.8	21.6	47.2	170.0	147.6
70	49.8	61.3	21.5	39.8	167.0	146.6
80	45.0	55.4	21.4	33.9	162.9	145.2
90	41.1	50.6	21.3	29.3	158.1	143.6
100	37.9	46.7	21.2	25.4	152.7	141.8
110	35.2	43.3	21.1	22.3	146.9	139.9
120	32.9	40.5	21.0	19.5	140.7	137.8

Storage: Roof Storage

Depth (mm)	Head (m)	Discharge (L/s)	Vreq (cu. m)	Vavail (cu. m)	Discharge Check
100-year Water Level	148.0	0.15	21.6	171.3	177.2 0.00

Stormwater Management Calculations

Project #160401570, 100 Steacie Drive
Modified Rational Method Calculations for Storage

Subdrainage Area: POND-1		Uncontrolled - Tributary to Pond				
Area (ha): 0.46						
C: 0.35						
tc (min)	I (5 yr) (mm/hr)	Qactual (L/s)	Qrelease (L/s)	Qstored (L/s)	Vstored (m ³)	
10	104.2	46.4	46.4			
20	70.3	31.3	31.3			
30	53.9	24.0	24.0			
40	44.2	19.7	19.7			
50	37.7	16.8	16.8			
60	32.9	14.7	14.7			
70	29.4	13.1	13.1			
80	26.6	11.8	11.8			
90	24.3	10.8	10.8			
100	22.4	10.0	10.0			
110	20.8	9.3	9.3			
120	19.5	8.7	8.7			

Subdrainage Area: C502A		Uncontrolled - Tributary to Pond				
Area (ha): 0.05						
C: 0.65						
tc (min)	I (5 yr) (mm/hr)	Qactual (L/s)	Qrelease (L/s)	Qstored (L/s)	Vstored (m ³)	
10	104.2	9.4	9.4			
20	70.3	6.4	6.4			
30	53.9	4.9	4.9			
40	44.2	4.0	4.0			
50	37.7	3.4	3.4			
60	32.9	3.0	3.0			
70	29.4	2.7	2.7			
80	26.6	2.4	2.4			
90	24.3	2.2	2.2			
100	22.4	2.0	2.0			
110	20.8	1.9	1.9			
120	19.5	1.8	1.8			

Subdrainage Area: C501A		Controlled - Tributary to Pond				
Area (ha): 0.15						
C: 0.27						
tc (min)	I (5 yr) (mm/hr)	Qactual (L/s)	Qrelease (L/s)	Qstored (L/s)	Vstored (m ³)	
10	104.2	12.1	12.1			
20	70.3	8.2	8.2			
30	53.9	6.3	6.3			
40	44.2	5.1	5.1			
50	37.7	4.4	4.4			
60	32.9	3.8	3.8			
70	29.4	3.4	3.4			
80	26.6	3.1	3.1			
90	24.3	2.8	2.8			
100	22.4	2.6	2.6			
110	20.8	2.4	2.4			
120	19.5	2.3	2.3			

Subdrainage Area: C500A		Controlled - Tributary to Pond				
Area (ha): 0.13						
C: 0.58						
tc (min)	I (5 yr) (mm/hr)	Qactual (L/s)	Qrelease (L/s)	Qstored (L/s)	Vstored (m ³)	
10	104.2	21.4	21.4			
20	70.3	14.4	14.4			
30	53.9	11.1	11.1			
40	44.2	9.1	9.1			
50	37.7	7.7	7.7			
60	32.9	6.8	6.8			
70	29.4	6.0	6.0			
80	26.6	5.4	5.4			
90	24.3	5.0	5.0			
100	22.4	4.6	4.6			
110	20.8	4.3	4.3			
120	19.5	4.0	4.0			

Subdrainage Area: UNC-4		Uncontrolled - Towards Ditch (West)				
Area (ha): 0.56						
C: 0.20						
tc (min)	I (5 yr) (mm/hr)	Qactual (L/s)	Qrelease (L/s)	Qstored (L/s)	Vstored (m ³)	
10	104.2	32.4	32.4			
20	70.3	21.8	21.8			
30	53.9	16.8	16.8			
40	44.2	13.7	13.7			
50	37.7	11.7	11.7			
60	32.9	10.2	10.2			
70	29.4	9.1	9.1			
80	26.6	8.3	8.3			
90	24.3	7.5	7.5			
100	22.4	7.0	7.0			
110	20.8	6.5	6.5			
120	19.5	6.0	6.0			

Project #160401570, 100 Steacie Drive
Modified Rational Method Calculations for Storage

Subdrainage Area: POND-1		Uncontrolled - Tributary to Pond				
Area (ha): 0.46						
C: 0.44						
tc (min)	I (100 yr) (mm/hr)	Qactual (L/s)	Qrelease (L/s)	Qstored (L/s)	Vstored (m ³)	
10	178.6	99.5	99.5			
20	120.0	66.8	66.8			
30	91.9	51.2	51.2			
40	75.1	41.9	41.9			
50	64.0	35.6	35.6			
60	55.9	31.1	31.1			
70	49.8	27.7	27.7			
80	45.0	25.1	25.1			
90	41.1	22.9	22.9			
100	37.9	21.1	21.1			
110	35.2	19.6	19.6			
120	32.9	18.3	18.3			

Subdrainage Area: C502A		Uncontrolled - Tributary to Pond				
Area (ha): 0.05						
C: 0.81						
tc (min)	I (100 yr) (mm/hr)	Qactual (L/s)	Qrelease (L/s)	Qstored (L/s)	Vstored (m ³)	
10	178.6	20.2	20.2			
20	120.0	13.6	13.6			
30	91.9	10.4	10.4			
40	75.1	8.5	8.5			
50	64.0	7.2	7.2			
60	55.9	6.3	6.3			
70	49.8	5.6	5.6			
80	45.0	5.1	5.1			
90	41.1	4.7	4.7			
100	37.9	4.3	4.3			
110	35.2	4.0	4.0			
120	32.9	3.7	3.7			

Subdrainage Area: C501A		Controlled - Tributary to Pond				
Area (ha): 0.15						
C: 0.34						
tc (min)	I (100 yr) (mm/hr)	Qactual (L/s)	Qrelease (L/s)	Qstored (L/s)	Vstored (m ³)	
10	178.6	26.0	26.0			
20	120.0	17.4	17.4			
30	91.9	13.4	13.4			
40	75.1	10.9	10.9			
50	64.0	9.3	9.3			
60	55.9	8.1	8.1			
70	49.8	7.2	7.2			
80	45.0	6.5	6.5			
90	41.1	6.0	6.0			
100	37.9	5.5	5.5			
110	35.2	5.1	5.1			
120	32.9	4.8	4.8			

Subdrainage Area: C500A		Controlled - Tributary to Pond				
Area (ha): 0.13						
C: 0.73						
tc (min)	I (100 yr) (mm/hr)	Qactual (L/s)	Qrelease (L/s)	Qstored (L/s)	Vstored (m ³)	
10	178.6	45.8	45.8			
20	120.0	30.8	30.8			
30	91.9	23.6	23.6			
40	75.1	19.3	19.3			
50	64.0	16.4	16.4			
60	55.9	14.3	14.3			
70	49.8	12.8	12.8			
80	45.0	11.5	11.5			
90	41.1	10.5	10.5			
100	37.9	9.7	9.7			
110	35.2	9.0	9.0			
120	32.9	8.4	8.4			

Subdrainage Area: UNC-4		Uncontrolled - Towards Ditch (West)				
Area (ha): 0.56						
C: 0.25						
tc (min)	I (100 yr) (mm/hr)	Qactual (L/s)	Qrelease (L/s)	Qstored (L/s)	Vstored (m ³)	
10	178.6	69.4	69.4			
20	120.0	46.6	46.6			
30	91.9	35.7	35.7			
40	75.1	29.2	29.2			
50	64.0	24.8	24.8			
60	55.9	21.7	21.7			
70	49.8	19.3	19.3			
80	45.0	17.5	17.5			
90	41.1	16.0	16.0			
100	37.9	14.7	14.7			
110	35.2	13.7	13.7			
120	32.9	12.8	12.8			

Roof Drain Design Calculation Sheet

**Project #160401570, 100 Steacie Drive
Roof Drain Design Sheet, Area R4A
Standard Watts Accutrol Weir - Single Notch Roof Drain**

Rating Curve				Volume Estimation				Water Depth (m)
Elevation (m)	Discharge Rate (cu.m/s)	Outlet Discharge (cu.m/s)	Storage (cu. m)	Elevation (m)	Area (sq. m)	Volume (cu. m)		
						Increment	Accumulated	
0.000	0.0000	0.0000	0	0.000	0	0	0	0.000
0.025	0.0003	0.0085	1	0.025	98	1	1	0.025
0.050	0.0006	0.0151	7	0.050	394	6	7	0.050
0.075	0.0007	0.0168	22	0.075	886	16	22	0.075
0.100	0.0008	0.0185	52	0.100	1575	30	52	0.100
0.125	0.0009	0.0201	103	0.125	2461	50	103	0.125
0.150	0.0009	0.0218	177	0.150	3543	75	177	0.150

Drawdown Estimate			
Total Volume (cu.m)	Total Time (sec)	Vol (cu.m)	Detention Time (hr)
0.0	0.0	0.0	0
5.7	379.2	5.7	0.10534
21.3	927.8	15.6	0.36306
51.7	1644.6	30.3	0.81991
101.7	2488.1	50.0	1.51106
176.3	3429.4	74.6	2.46367

Rooftop Storage Summary

Total Building Area (sq.m)		4428.99	
Assume Available Roof Area (sq. 80%)		3543.192	
Roof Imperviousness		0.99	
Roof Drain Requirement (sq.m/Notch)		232	
Number of Roof Notches*		16	
Max. Allowable Depth of Roof Ponding (m)		0.15	* As per Ontario Building Code section OBC 7.4.10.4.(2)(c).
Max. Allowable Storage (cu.m)		177	
Estimated 100 Year Drawdown Time (h)		2.4	

* Note: Number of drains can be reduced if multiple-notch drain used.

Adjustable Accutrol Weir Flow Rate Settings From Watts Drain Catalogue					
Head (m)	L/s				
	Open	75%	50%	25%	Closed
0.025	0.3154	0.3154	0.3154	0.3154	0.3154
0.05	0.6308	0.6308	0.6308	0.6308	0.3154
0.075	0.9462	0.8674	0.7885	0.7097	0.3154
0.1	1.2617	1.104	0.9462	0.7885	0.3154
0.125	1.5771	1.3405	1.104	0.8674	0.3154
0.15	1.8925	1.5771	1.2617	0.9462	0.3154

Calculation Results

	5yr	100yr	Available
Qresult (cu.m/s)	0.019	0.022	-
Depth (m)	0.110	0.148	0.150
Volume (cu.m)	73.1	171.3	177.2
Drain time (hrs)	1.1	2.4	

C.3 Stormceptor Sizing Report



Stormceptor® EF Sizing Report

Imbrium® Systems

ESTIMATED NET ANNUAL SEDIMENT (TSS) LOAD REDUCTION

04/04/2024

Province:	Ontario	Project Name:	100 Steacie Drive
City:	Ottawa	Project Number:	160401570
Nearest Rainfall Station:	OTTAWA CDA RCS	Designer Name:	Michael Wu
Climate Station Id:	6105978	Designer Company:	Stantec
Years of Rainfall Data:	20	Designer Email:	Michael.Wu@stantec.com
Site Name:		Designer Phone:	613-738-6033
Drainage Area (ha):	1.244	EOR Name:	
Runoff Coefficient 'c':	0.58	EOR Company:	
Particle Size Distribution:	Fine	EOR Email:	
Target TSS Removal (%):	80.0	EOR Phone:	

Required Water Quality Runoff Volume Capture (%):	90.00
Estimated Water Quality Flow Rate (L/s):	23.29
Oil / Fuel Spill Risk Site?	Yes
Upstream Flow Control?	No
Peak Conveyance (maximum) Flow Rate (L/s):	
Influent TSS Concentration (mg/L):	200
Estimated Average Annual Sediment Load (kg/yr):	695
Estimated Average Annual Sediment Volume (L/yr):	565

Net Annual Sediment (TSS) Load Reduction Sizing Summary	
Stormceptor Model	TSS Removal Provided (%)
EFO4	77
EFO6	88
EFO8	94
EFO10	96
EFO12	98

Recommended Stormceptor EFO Model: EFO6
Estimated Net Annual Sediment (TSS) Load Reduction (%): 88
Water Quality Runoff Volume Capture (%): > 90

THIRD-PARTY TESTING AND VERIFICATION

► **Stormceptor® EF and Stormceptor® EFO** are the latest evolutions in the Stormceptor® oil-grit separator (OGS) technology series, and are designed to remove a wide variety of pollutants from stormwater and snowmelt runoff. These technologies have been third-party tested in accordance with the Canadian ETV **Procedure for Laboratory Testing of Oil-Grit Separators** and performance has been third-party verified in accordance with the **ISO 14034 Environmental Technology Verification (ETV)** protocol.

PERFORMANCE

► **Stormceptor® EF and EFO** remove stormwater pollutants through gravity separation and floatation, and feature a patent-pending design that generates positive removal of total suspended solids (TSS) throughout each storm event, including high-intensity storms. Captured pollutants include sediment, free oils, and sediment-bound pollutants such as nutrients, heavy metals, and petroleum hydrocarbons. Stormceptor is sized to remove a high level of TSS from the frequent rainfall events that contribute the vast majority of annual runoff volume and pollutant load. The technology incorporates an internal bypass to convey excessive stormwater flows from high-intensity storms through the device without resuspension and washout (scour) of previously captured pollutants. Proper routine maintenance ensures high pollutant removal performance and protection of downstream waterways.

PARTICLE SIZE DISTRIBUTION (PSD)

► The **Canadian ETV PSD** shown in the table below was used, or in part, for this sizing. This is the identical PSD that is referenced in the Canadian ETV **Procedure for Laboratory Testing of Oil-Grit Separators** for both sediment removal testing and scour testing. The Canadian ETV PSD contains a wide range of particle sizes in the sand and silt fractions, and is considered reasonably representative of the particle size fractions found in typical urban stormwater runoff.

Particle Size (µm)	Percent Less Than	Particle Size Fraction (µm)	Percent
1000	100	500-1000	5
500	95	250-500	5
250	90	150-250	15
150	75	100-150	15
100	60	75-100	10
75	50	50-75	5
50	45	20-50	10
20	35	8-20	15
8	20	5-8	10
5	10	2-5	5
2	5	<2	5

Stormceptor® EF Sizing Report

Rainfall Intensity (mm / hr)	Percent Rainfall Volume (%)	Cumulative Rainfall Volume (%)	Flow Rate (L/s)	Flow Rate (L/min)	Surface Loading Rate (L/min/m ²)	Removal Efficiency (%)	Incremental Removal (%)	Cumulative Removal (%)
0.50	8.6	8.6	1.00	60.0	23.0	100	8.6	8.6
1.00	20.3	29.0	2.01	120.0	46.0	100	20.3	29.0
2.00	16.2	45.2	4.01	241.0	92.0	97	15.8	44.7
3.00	12.0	57.2	6.02	361.0	137.0	92	11.0	55.8
4.00	8.4	65.6	8.02	481.0	183.0	86	7.2	63.0
5.00	5.9	71.6	10.03	602.0	229.0	82	4.9	67.9
6.00	4.6	76.2	12.03	722.0	275.0	80	3.7	71.6
7.00	3.1	79.3	14.04	842.0	320.0	78	2.4	74.0
8.00	2.7	82.0	16.05	963.0	366.0	76	2.1	76.0
9.00	3.3	85.3	18.05	1083.0	412.0	73	2.4	78.5
10.00	2.3	87.6	20.06	1203.0	458.0	72	1.6	80.1
11.00	1.6	89.2	22.06	1324.0	503.0	69	1.1	81.2
12.00	1.3	90.5	24.07	1444.0	549.0	67	0.9	82.1
13.00	1.7	92.2	26.08	1565.0	595.0	65	1.1	83.2
14.00	1.2	93.5	28.08	1685.0	641.0	64	0.8	84.0
15.00	1.2	94.6	30.09	1805.0	686.0	64	0.7	84.7
16.00	0.7	95.3	32.09	1926.0	732.0	64	0.4	85.2
17.00	0.7	96.1	34.10	2046.0	778.0	63	0.5	85.6
18.00	0.4	96.5	36.10	2166.0	824.0	63	0.3	85.9
19.00	0.4	96.9	38.11	2287.0	869.0	63	0.3	86.2
20.00	0.2	97.1	40.12	2407.0	915.0	62	0.1	86.3
21.00	0.5	97.5	42.12	2527.0	961.0	62	0.3	86.6
22.00	0.2	97.8	44.13	2648.0	1007.0	62	0.2	86.7
23.00	1.0	98.8	46.13	2768.0	1052.0	60	0.6	87.3
24.00	0.3	99.1	48.14	2888.0	1098.0	59	0.2	87.5
25.00	0.0	99.1	50.15	3009.0	1144.0	58	0.0	87.5
30.00	0.9	100.0	60.17	3610.0	1373.0	53	0.5	88.0
35.00	0.0	100.0	70.20	4212.0	1602.0	46	0.0	88.0
40.00	0.0	100.0	80.23	4814.0	1830.0	40	0.0	88.0
45.00	0.0	100.0	90.26	5416.0	2059.0	36	0.0	88.0
Estimated Net Annual Sediment (TSS) Load Reduction =								88 %

Climate Station ID: 6105978 Years of Rainfall Data: 20

Stormceptor® EF Sizing Report

RAINFALL DATA FROM OTTAWA CDA RCS RAINFALL STATION

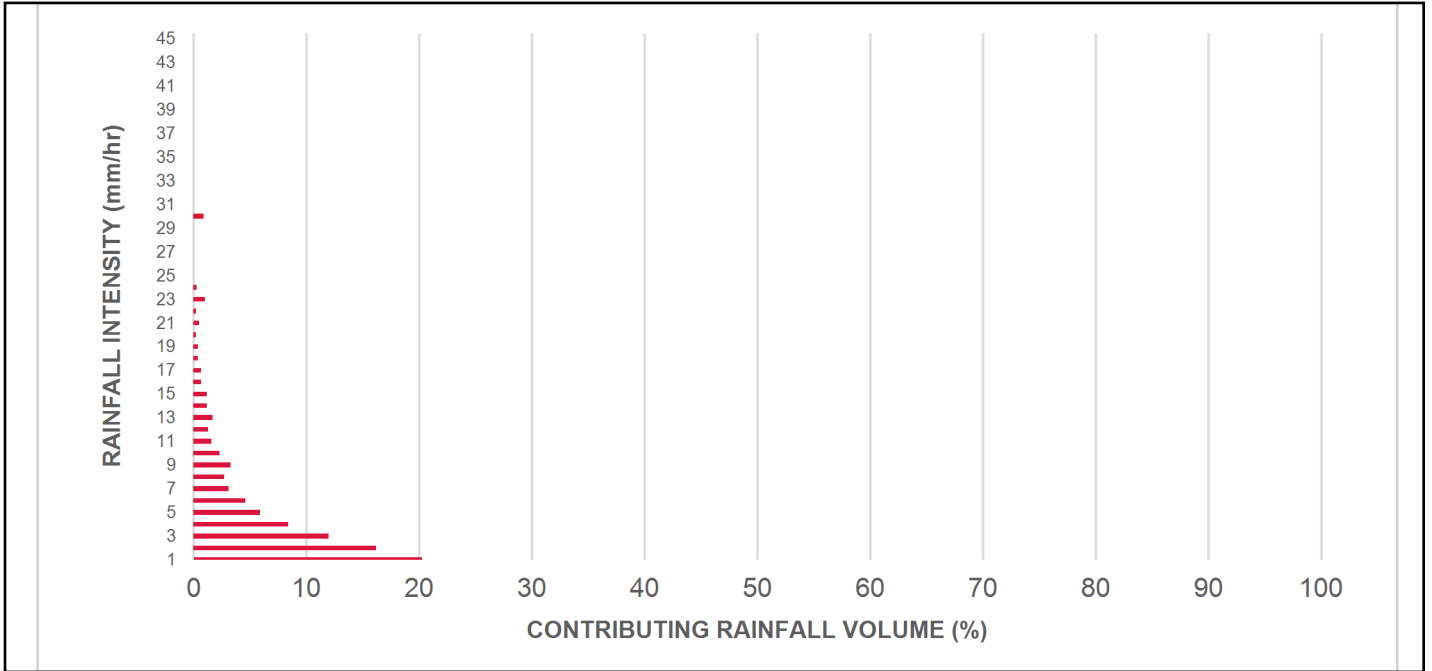

INCREMENTAL AND CUMULATIVE TSS REMOVAL FOR THE RECOMMENDED STORMCEPTOR® MODEL

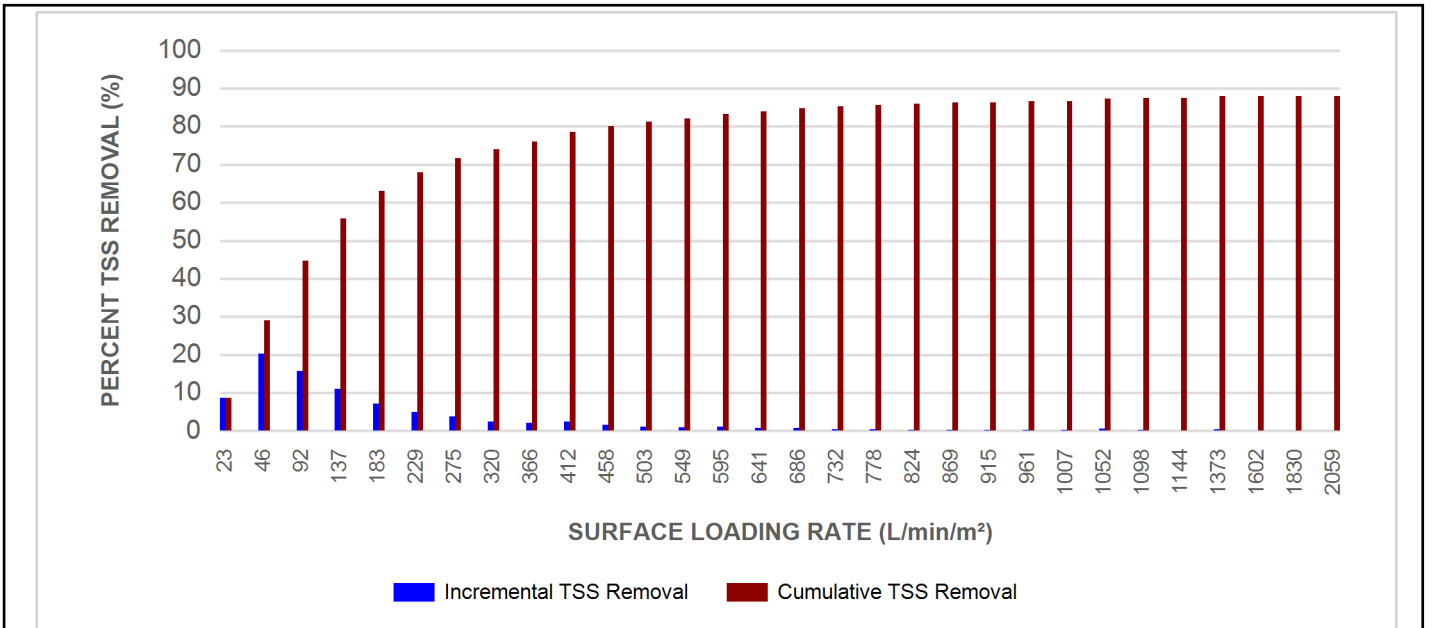

Stormceptor® EF Sizing Report

Maximum Pipe Diameter / Peak Conveyance

Stormceptor EF / EFO	Model Diameter		Min Angle Inlet / Outlet Pipes	Max Inlet Pipe Diameter		Max Outlet Pipe Diameter		Peak Conveyance Flow Rate	
	(m)	(ft)		(mm)	(in)	(mm)	(in)	(L/s)	(cfs)
EF4 / EFO4	1.2	4	90	609	24	609	24	425	15
EF6 / EFO6	1.8	6	90	914	36	914	36	990	35
EF8 / EFO8	2.4	8	90	1219	48	1219	48	1700	60
EF10 / EFO10	3.0	10	90	1828	72	1828	72	2830	100
EF12 / EFO12	3.6	12	90	1828	72	1828	72	2830	100

SCOUR PREVENTION AND ONLINE CONFIGURATION

► Stormceptor® EF and EFO feature an internal bypass and superior scour prevention technology that have been demonstrated in third-party testing according to the scour testing provisions of the Canadian ETV **Procedure for Laboratory Testing of Oil-Grit Separators**, and the exceptional scour test performance has been third-party verified in accordance with the ISO 14034 ETV protocol. As a result, Stormceptor EF and EFO are approved for online installation, eliminating the need for costly additional bypass structures, piping, and installation expense.

DESIGN FLEXIBILITY

► Stormceptor® EF and EFO offers design flexibility in one simplified platform, accepting stormwater flow from a single inlet pipe or multiple inlet pipes, and/or surface runoff through an inlet grate. The device can also serve as a junction structure, accommodate a 90-degree inlet-to-outlet bend angle, and can be modified to ensure performance in submerged conditions.

OIL CAPTURE AND RETENTION

► While Stormceptor® EF will capture and retain oil from dry weather spills and low intensity runoff, Stormceptor® EFO has demonstrated superior oil capture and greater than 99% oil retention in third-party testing according to the light liquid re-entrainment testing provisions of the Canadian ETV **Procedure for Laboratory Testing of Oil-Grit Separators**. Stormceptor EFO is recommended for sites where oil capture and retention is a requirement.

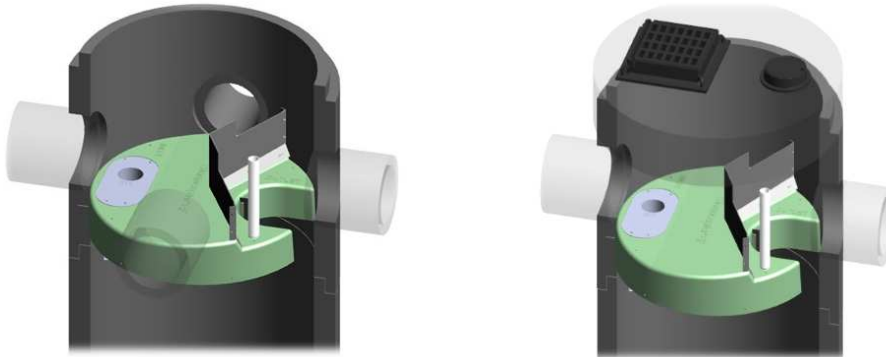

Stormceptor® EF Sizing Report

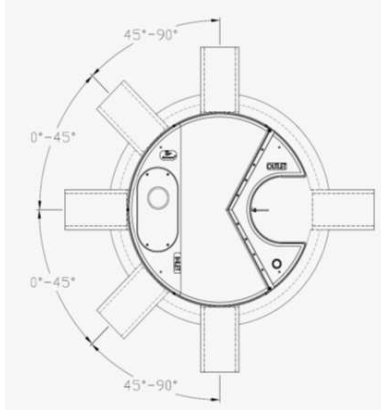

INLET-TO-OUTLET DROP

Elevation differential between inlet and outlet pipe inverts is dictated by the angle at which the inlet pipe(s) enters the unit.

0° - 45° : The inlet pipe is 1-inch (25mm) higher than the outlet pipe.

45° - 90° : The inlet pipe is 2-inches (50mm) higher than the outlet pipe.

HEAD LOSS

The head loss through Stormceptor EF is similar to that of a 60-degree bend structure. The applicable K value for calculating minor losses through the unit is 1.1. For submerged conditions the applicable K value is 3.0.

Pollutant Capacity

Stormceptor EF / EFO	Model Diameter		Depth (Outlet Pipe Invert to Sump Floor)		Oil Volume		Recommended Sediment Maintenance Depth *		Maximum Sediment Volume *		Maximum Sediment Mass **	
	(m)	(ft)	(m)	(ft)	(L)	(Gal)	(mm)	(in)	(L)	(ft³)	(kg)	(lb)
EF4 / EFO4	1.2	4	1.52	5.0	265	70	203	8	1190	42	1904	5250
EF6 / EFO6	1.8	6	1.93	6.3	610	160	305	12	3470	123	5552	15375
EF8 / EFO8	2.4	8	2.59	8.5	1070	280	610	24	8780	310	14048	38750
EF10 / EFO10	3.0	10	3.25	10.7	1670	440	610	24	17790	628	28464	78500
EF12 / EFO12	3.6	12	3.89	12.8	2475	655	610	24	31220	1103	49952	137875

*Increased sump depth may be added to increase sediment storage capacity

** Average density of wet packed sediment in sump = 1.6 kg/L (100 lb/ft³)

Feature	Benefit	Feature Appeals To
Patent-pending enhanced flow treatment and scour prevention technology	Superior, verified third-party performance	Regulator, Specifying & Design Engineer
Third-party verified light liquid capture and retention for EFO version	Proven performance for fuel/oil hotspot locations	Regulator, Specifying & Design Engineer, Site Owner
Functions as bend, junction or inlet structure	Design flexibility	Specifying & Design Engineer
Minimal drop between inlet and outlet	Site installation ease	Contractor
Large diameter outlet riser for inspection and maintenance	Easy maintenance access from grade	Maintenance Contractor & Site Owner

STANDARD STORMCEPTOR EF/EFO DRAWINGS

For standard details, please visit <http://www.imbriumsystems.com/stormwater-treatment-solutions/stormceptor-ef>

STANDARD STORMCEPTOR EF/EFO SPECIFICATION

For specifications, please visit <http://www.imbriumsystems.com/stormwater-treatment-solutions/stormceptor-ef>

STANDARD PERFORMANCE SPECIFICATION FOR “OIL GRIT SEPARATOR” (OGS) STORMWATER QUALITY TREATMENT DEVICE

PART 1 – GENERAL

1.1 WORK INCLUDED

This section specifies requirements for selecting, sizing, and designing an underground Oil Grit Separator (OGS) device for stormwater quality treatment, with third-party testing results and a Statement of Verification in accordance with ISO 14034 Environmental Management – Environmental Technology Verification (ETV).

1.2 REFERENCE STANDARDS & PROCEDURES

ISO 14034:2016 Environmental management – Environmental technology verification (ETV)

Canadian Environmental Technology Verification (ETV) Program’s **Procedure for Laboratory Testing of Oil-Grit Separators**

1.3 SUBMITTALS

1.3.1 All submittals, including sizing reports & shop drawings, shall be submitted upon request with each order to the contractor then forwarded to the Engineer of Record for review and acceptance. Shop drawings shall detail all OGS components, elevations, and sequence of construction.

1.3.2 Alternative devices shall have features identical to or greater than the specified device, including: treatment chamber diameter, treatment chamber wet volume, sediment storage volume, and oil storage volume.

1.3.3 Unless directed otherwise by the Engineer of Record, OGS stormwater quality treatment product substitutions or alternatives submitted within ten days prior to project bid shall not be accepted. All alternatives or substitutions submitted shall be signed and sealed by a local registered Professional Engineer, based on the exact same criteria detailed in Section 3, in entirety, subject to review and approval by the Engineer of Record.

PART 2 – PRODUCTS

2.1 OGS POLLUTANT STORAGE

The OGS device shall include a sump for sediment storage, and a protected volume for the capture and storage of petroleum hydrocarbons and buoyant gross pollutants. The minimum sediment & petroleum hydrocarbon storage capacity shall be as follows:

2.1.1	4 ft (1219 mm) Diameter OGS Units:	1.19 m ³ sediment / 265 L oil
	6 ft (1829 mm) Diameter OGS Units:	3.48 m ³ sediment / 609 L oil
	8 ft (2438 mm) Diameter OGS Units:	8.78 m ³ sediment / 1,071 L oil
	10 ft (3048 mm) Diameter OGS Units:	17.78 m ³ sediment / 1,673 L oil
	12 ft (3657 mm) Diameter OGS Units:	31.23 m ³ sediment / 2,476 L oil

PART 3 – PERFORMANCE & DESIGN

3.1 GENERAL

The OGS stormwater quality treatment device shall be verified in accordance with ISO 14034:2016 Environmental management – Environmental technology verification (ETV). The OGS stormwater quality treatment device shall

Stormceptor® EF Sizing Report

remove oil, sediment and gross pollutants from stormwater runoff during frequent wet weather events, and retain these pollutants during less frequent high flow wet weather events below the insert within the OGS for later removal during maintenance. The Manufacturer shall have at least ten (10) years of local experience, history and success in engineering design, manufacturing and production and supply of OGS stormwater quality treatment device systems, acceptable to the Engineer of Record.

3.2 SIZING METHODOLOGY

The OGS device shall be engineered, designed and sized to provide stormwater quality treatment based on treating a minimum of 90 percent of the average annual runoff volume and a minimum removal of an annual average 60% of the sediment (TSS) load based on the Particle Size Distribution (PSD) specified in the sizing report for the specified device. Sizing of the OGS shall be determined by use of a minimum ten (10) years of local historical rainfall data provided by Environment Canada. Sizing shall also be determined by use of the sediment removal performance data derived from the ISO 14034 ETV third-party verified laboratory testing data from testing conducted in accordance with the Canadian ETV protocol Procedure for Laboratory Testing of Oil-Grit Separators, as follows:

3.2.1 Sediment removal efficiency for a given surface loading rate and its associated flow rate shall be based on sediment removal efficiency demonstrated at the seven (7) tested surface loading rates specified in the protocol, ranging 40 L/min/m² to 1400 L/min/m², and as stated in the ISO 14034 ETV Verification Statement for the OGS device.

3.2.2 Sediment removal efficiency for surface loading rates between 40 L/min/m² and 1400 L/min/m² shall be based on linear interpolation of data between consecutive tested surface loading rates.

3.2.3 Sediment removal efficiency for surface loading rates less than the lowest tested surface loading rate of 40 L/min/m² shall be assumed to be identical to the sediment removal efficiency at 40 L/min/m². No extrapolation shall be allowed that results in a sediment removal efficiency that is greater than that demonstrated at 40 L/min/m².

3.2.4 Sediment removal efficiency for surface loading rates greater than the highest tested surface loading rate of 1400 L/min/m² shall assume zero sediment removal for the portion of flow that exceeds 1400 L/min/m², and shall be calculated using a simple proportioning formula, with 1400 L/min/m² in the numerator and the higher surface loading rate in the denominator, and multiplying the resulting fraction times the sediment removal efficiency at 1400 L/min/m².

The OGS device shall also have sufficient annual sediment storage capacity as specified and calculated in Section 2.1.

3.3 CANADIAN ETV or ISO 14034 ETV VERIFICATION OF SCOUR TESTING

The OGS device shall have Canadian ETV or ISO 14034 ETV Verification of third-party scour testing conducted in accordance with the Canadian ETV Program's **Procedure for Laboratory Testing of Oil-Grit Separators**.

3.3.1 To be acceptable for on-line installation, the OGS device must demonstrate an average scour test effluent concentration less than 10 mg/L at each surface loading rate tested, up to and including 2600 L/min/m².

3.4 LIGHT LIQUID RE-ENTRAINMENT SIMULATION TESTING

The OGS device shall have Canadian ETV or ISO 14034 ETV Verification of completed third-party Light Liquid Re-entrainment Simulation Testing in accordance with the Canadian ETV **Program's Procedure for Laboratory Testing of Oil-Grit Separators**, with results reported within the Canadian ETV or ISO 14034 ETV verification. This re-entrainment testing is conducted with the device pre-loaded with low density polyethylene (LDPE) plastic beads as a surrogate for light liquids such as oil and fuel. Testing is conducted on the same OGS unit tested for sediment removal to

Stormceptor® EF Sizing Report

assess whether light liquids captured after a spill are effectively retained at high flow rates.

3.4.1 For an OGS device to be an acceptable stormwater treatment device on a site where vehicular traffic occurs and the potential for an oil or fuel spill exists, the OGS device must have reported verified performance results of greater than 99% cumulative retention of LDPE plastic beads for the five specified surface loading rates (ranging 200 L/min/m² to 2600 L/min/m²) in accordance with the Light Liquid Re-entrainment Simulation Testing within the Canadian ETV Program's **Procedure for Laboratory Testing of Oil-Grit Separators**. However, an OGS device shall not be allowed if the Light Liquid Re-entrainment Simulation Testing was performed with screening components within the OGS device that are effective at retaining the LDPE plastic beads, but would not be expected to retain light liquids such as oil and fuel.

Appendix D External Reports



MOREY HOULE CHEVRIER ENGINEERING LTD.

5497 Manotick Main Street
P.O. Box 59
Ottawa, Ontario K4M 1A2
Tel.: (613) 692-8686
Fax: (613) 692-6411
www.mhceng.com



REPORT ON

1. 60.8-6-2

GEOTECHNICAL INVESTIGATION
PROPOSED RESIDENTIAL DEVELOPMENT
STEACIE DRIVE
KANATA, ONTARIO

Submitted to:

Andridge Capital Corporation
451 Daly Avenue, 2nd Floor
Ottawa, Ontario
K1N 6H6

DISTRIBUTION:

4 copies - Andridge Capital Corporation
2 copies - Morey Houle Chevrier Engineering Ltd.

May 2005

05-068

MOREY HOULE CHEVRIER ENGINEERING LTD.

5497 Manotick Main Street
P.O. Box 59
Ottawa, Ontario K4M 1A2
Tel.: (613) 692-8686
Fax: (613) 692-6411
www.mhceng.com



May 5, 2005

Our Ref: 05-068

Andridge Capital Corporation
451 Daly Avenue, 2nd Floor
Ottawa, Ontario
K1N 6H6

RE: GEOTECHNICAL INVESTIGATION
PROPOSED RESIDENTIAL DEVELOPMENT
STEACIE DRIVE
KANATA, ONTARIO

Dear Sirs:

This report presents the results of a subsurface investigation carried out at the site of a proposed residential townhouse development located north and west of the cul-de-sac on Steacie Drive in Kanata, Ontario. The purpose of the investigation was to identify the general subsurface conditions at the site by means of a limited number of boreholes. Based on the factual information obtained, engineering guidelines were to be provided on the geotechnical aspects of the design of the project, including construction considerations which could influence design decisions.

A preliminary subsurface investigation of part of this site was carried out in 2000 by Morey Houle Chevrier Engineering Ltd. (Report No. 002-080).

PROJECT DESCRIPTION AND SITE GEOLOGY

Plans are being prepared for a residential development consisting of a total of fifty-two (52) townhouse units with eight (8) blocks of six (6) units and one (1) block of four (4) units on the vacant parcel of land north and west of the cul-de-sac on Steacie Drive in Kanata, Ontario (see Key Plan, Figure 1). The townhouses will likely be of slab on grade (basementless) construction with conventional wood framing. Access to the site will be provided by means of an internal roadway. The site will be serviced with watermains, and storm and sanitary sewers.

The site is currently undeveloped with a combination of grass and tree cover and a hilly to rolling topography. The site is bordered by railway tracks to the north, commercial developments to the east, and parkland and residential development to the south and west.

Surficial geology maps of the Ottawa area indicate that the site is underlain by thin, discontinuous deposits composed of clay and silt of marine origin. Drift thickness maps indicate that the overburden in the vicinity of the site ranges in thickness from 0 to 10 metres. Bedrock geology maps indicate that the overburden is underlain by non carbonate, quartzite metasedimentary bedrock. The previous preliminary subsurface investigation encountered some fill material and topsoil underlain by deposits of sensitive silty clay and glacial till above bedrock.

SUBSURFACE INVESTIGATION

The field work for this investigation was carried out between April 7 and April 14, 2005. At that time, sixteen (16) boreholes, numbered 1 to 12, 12A and 13 to 15, inclusive, were advanced at the site to depths of between about 1.2 and 5.8 metres below existing ground surface using a track mounted drill rig supplied and operated by Marathon Drilling Co. Ltd. of Ottawa, Ontario. Standard penetration testing was carried out in the boreholes at regular intervals of depth and samples of the soils encountered were recovered using drive open sampling equipment. Standpipes were sealed into two (2) of the boreholes to monitor groundwater levels.

The field work was supervised throughout by a member of our engineering staff, who directed the drilling, and logged the boreholes.

The results of the boreholes are provided on the Record of Borehole sheets following the text of this report. The approximate locations of the boreholes are shown on the Site Plan, Figure 2.

The borehole locations and geodetic elevations were provided to us by David McManus Engineering Ltd.

SUBSURFACE CONDITIONS

General

As previously indicated, the soil, bedrock and groundwater conditions logged in the boreholes are given on the Record of Borehole sheets following the text of this report. The borehole logs indicate the subsurface conditions at the specific test locations only. Boundaries between zones on the logs are often not distinct, but rather are transitional and have been interpreted. Subsurface conditions at other than the borehole locations may vary from the conditions encountered in the boreholes. In addition to soil variability, fill of variable physical and chemical composition can be present over portions of the site.

The soil descriptions in this report are based on commonly accepted methods of classification and identification employed in geotechnical practice. Classification and identification of soil involves judgement and Morey Houle Chevrier Engineering Ltd. does not guarantee descriptions as exact, but infers accuracy to the extent that is common in current geotechnical practice.

The following presents an overview of the subsurface conditions encountered in the boreholes advanced during this investigation.

Topsoil, Former Topsoil

All of the boreholes encountered a surficial layer of topsoil from ground surface with the exception of boreholes 8 and 14. The topsoil is composed of silty sand and has a thickness ranging from about 30 to 300 millimetres.

Borehole 14 encountered a former topsoil layer below a surficial layer of fill material. At the borehole location the former topsoil layer has a thickness of about 100 millimetres.

Fill

Fill material was encountered from ground surface in boreholes 8 and 14. At the location of borehole 8 the fill material consists of grey brown silty sand and clayey silt with some boulders, metal wire and brick and has a thickness of about 0.5 metres. At the location of borehole 14 the fill material consists of silty clay and has a thickness of about 0.1 metres.

Sand, Silty Sand

A deposit of silty sand with some gravel was encountered below the weathered silty clay in borehole 5 at a depth of about 0.5 metres below ground surface. Standard penetration tests carried out within the silty sand deposit gave N values of 5 and 10 blows per 0.3 metres, which indicate a loose relative density. The thickness of this deposit was about 1.5 metres.

Borehole 6 encountered a deposit of grey brown fine to coarse sand with some silt and gravel at a depth of about 0.5 metres. A standard penetration test carried out within this material gave an N value of 12 blows per 0.3 metres, which indicates a compact relative density. The thickness of this deposit was about 1 metre.

Clayey Silt

A deposit of clayey silt with some gravel and cobbles was encountered below the topsoil in borehole 6 at a depth of about 0.2 metres. The thickness of this deposit was about 0.4 metres.

Silty Clay

At the location of boreholes 1, 2, 4, 7, 8, 9 and 12 to 15 the topsoil and surficial fill material are underlain by a relatively thick deposit of sensitive silty clay of marine origin (commonly referred to as Leda Clay). Boreholes 3, 5 and 6 encountered silty clay below a layer of silty sand/sand at depths ranging from about 0.4 to 2.0 metres. The upper part of the silty clay is weathered grey brown. Standard penetration tests carried out in the weathered silty clay gave N values ranging from 5 to 26 blows per 0.3 metres of penetration, which reflect a very stiff to stiff consistency.

Below the upper weathered zone, the silty clay is grey in colour. In situ vane shear tests carried out in the grey clay gave undrained shear strength values ranging from about 31 to 69 kilopascals. These tests indicate that the grey clay has a firm to stiff consistency. Remoulded vane shear strength tests carried out in the grey silty clay gave values ranging from 3 to 15 kilopascals. The lower values reflect the sensitive nature of this material.

Glacial Till

Boreholes 1, 2, 5 and 7 to 12, inclusive, encountered a deposit of glacial till at depths ranging from about 0.1 to 5.3 metres below ground surface. The glacial till is a heterogeneous mixture of all grain sizes but may be generally described as a silty sand with variable amounts of clay, gravel, cobbles and boulders. Standard penetration tests carried out in the glacial till gave N values ranging from 5 to 25 blows per 0.3 metres, which indicates a loose to compact relative density.

Bedrock

Boreholes 1, 2, 5 and 7 to 12A, inclusive, encountered amphibolite bedrock at depths ranging from about 0.9 to 5.4 metres below existing ground surface. The bedrock was cored in boreholes 10 and 12A. In borehole 10 a total of 1.57 metres of bedrock was cored and the Total Core Recovery (TCR), Solid Core Recovery (SCR) and Rock Quality Designation (RQD) values are 100 percent, 91 percent and 73 percent, respectively. In borehole 12A a total of 1.58 metres of bedrock was cored and the TCR, SCR, and RQD values are 100 percent, 80 percent and 63 percent, respectively.

Groundwater Conditions

Groundwater levels were measured in the standpipes installed in boreholes 12 and 15 on April 14, 2005. At this time the groundwater levels ranged from about 0.2 to 0.6 metres below ground surface. Pooled surface water was noted in the vicinity of the boreholes advanced in the lower lying areas.

It should be noted that the groundwater levels may be higher during wet periods of the year, such as the early spring or fall or following periods of heavy precipitation. Groundwater levels at the site can also be affected by nearby construction activities.

PROPOSED RESIDENTIAL TOWNHOUSE DEVELOPMENT

General

This section of the report provides engineering guidelines on the geotechnical design aspects of the project based on our interpretation of the available borehole information, and the project requirements. It is stressed that the information in the following sections is provided for the guidance of the designers and is intended for this project only. Contractors bidding on or undertaking the works should examine the factual

results of the investigation, satisfy themselves as to the adequacy of the information for construction, and make their own interpretation of the factual data as it affects their construction techniques, schedule, safety and equipment capabilities.

The professional services retained for this project include only the geotechnical aspects of the subsurface conditions at this site. The presence or implications of possible surface and/or subsurface contamination resulting from previous uses or activities of this site or adjacent properties, and/or resulting from the introduction onto the site from materials from off site sources are outside the terms of reference for this report and have not been investigated or addressed.

Proposed Townhouses

Foundations

The native silty sand, and sand deposits above the groundwater level and the silty clay, glacial till and bedrock both above and below the groundwater level are considered suitable for the support of structures on conventional spread footing foundations. The silty sand and sand deposits below the groundwater level may become disturbed during excavation and by groundwater seepage and thereby, may not provide suitable support unless these areas are pre-drained in advance of excavation or as the excavation proceeds in stages. Further details could be provided if and when required. It is noted that a Permit to Take Water will be required from the Ministry of Environment for pumping during construction in excess of 50,000 litres per day. The excavations for the foundations should be taken through any surficial fill, topsoil, organic soils or otherwise deleterious material to expose undisturbed native silty sand, sand, silty clay, glacial till or bedrock. If bedrock areas of the site are pre-blasted to facilitate the installation of services, spread footings may also be placed on the surface of the pre-blasted rock provided that:

- 1) The thickness of the pre-blasted bedrock below the foundation level is not greater than about 1.0 metres, and;
- 2) Proof-rolling of the surface of pre-blasted bedrock is carried out using a large (i.e. 1.5 metre diameter) steel drum highway roller with the geotechnical engineer present to observe the response of the subgrade.

Based on the somewhat low topography in some areas, it is expected that these areas will likely be raised. In areas where proposed founding level is above the level of the native silty sand, sand, silty clay, glacial till or bedrock, or where subexcavation of disturbed material is required below proposed founding level, imported granular material (engineered fill) should be used. The engineered fill should consist of granular material meeting Ontario Provincial Standard Specifications (OPSS) requirements for Granular B Type II and should be compacted in maximum 200 millimetre thick lifts to at least 95 percent of the standard Proctor maximum dry density. In areas where groundwater inflow is encountered pumping should be carried out from sumps in the excavations during placement of the engineered fill. In areas where silty sand deposits exist below the engineered fill, it may be necessary to place a relatively thick lift of engineered fill on the silty sand and to compact it statically (without vibration) with a steel drum roller to avoid disturbance of the subgrade. To allow spread of load beneath the footings, the engineered fill should extend horizontally at least 0.5 metres beyond the footings and then down and out from the edges of the footings at 1 horizontal to 1 vertical, or flatter. The excavations for the residential dwellings should be sized to accommodate this fill placement. Currently, OPSS documents allow recycled asphaltic concrete and concrete to be used in Granular B Type II materials. Since the source of recycled material cannot be determined, it is suggested that any granular materials used below founding level be composed of virgin material only.

Based on the results of the boreholes, the following may be used to size the spread footing foundation:

Subgrade Material	Allowable Bearing Pressure for Foundations
Sand, Silty Sand	100 kilopascals
Grey Brown Silty Clay, weathered crust	150 kilopascals
Glacial Till	100 kilopascals
Sound Bedrock	300 kilopascals
Engineered Fill over suitable soil subgrade or pre-blasted bedrock	150 kilopascals
Pre-blasted bedrock	150 kilopascals

Note: The allowable bearing pressures assume that the native soils are in an undisturbed state.

There may be areas on this site where the subgrade material at founding level transitions from overburden to bedrock. To reduce the potential for cracking of basement foundation walls above abrupt transitions from overburden to bedrock, it is suggested that the foundations walls in the transition zone be suitably reinforced. Provided that any loose or disturbed soil is removed from the bearing surfaces prior to placing concrete or engineered fill, the settlement of the footings should be less than 25 millimetres.

Based on our experience in this area, the bedrock surface may be irregular or stepped. As such, provision should be made for additional formwork and concrete for footings bearing on the surface of the bedrock.

Frost Protection of Footings

All exterior footings and those in any unheated parts of the structures should be provided with at least 1.5 metres of earth cover for frost protection purposes. The depth of frost cover could be reduced for footings bearing on sound bedrock which does not have any soil filled seams or for footings on engineered fill. If 1.5 metres of earth cover is not practicable, a combination of earth cover and polystyrene insulation could be considered. Further details regarding the insulation of foundations could be provided upon request.

Basement Foundation Wall Backfill and Drainage

For slab on grade structures, the below grade portions of the foundations should be backfilled with non-frost susceptible sand or sand and gravel. Perimeter foundation drainage is not considered necessary for slab on grade structures provided that the slab is above the exterior finished grade.

If some of the units are to be constructed with basements, in accordance with the Ontario Building Code, the following alternatives could be considered for drainage of the basement foundation walls:

- Damp proof the exterior of the foundation walls and backfill the walls with free draining, non-frost susceptible sand or sand and gravel such as that meeting Ontario Provincial Standard Specifications (OPSS) requirements for Granular B Type I. OR
- Install an approved proprietary drainage material (such as System Platon) on the exterior of the foundation walls and backfill the walls with native material or imported soil.

Where the granular backfill will ultimately support a pavement structure or walkway, it is suggested that the backfill materials be compacted in maximum 200 millimetre thick loose lifts to at least 95 percent of the Standard Proctor maximum dry density value.

A perforated drain should be installed around the basement area at the level of the bottom of the footings. The drain should outlet to a sump from which the water is pumped or should drain by gravity to a storm sewer.

Garage Foundation and Pier Backfill

To avoid adfreeze between the unheated garage foundation walls and the wall backfill, the interior and exterior of the garage foundation walls should be backfilled with free draining, non-frost susceptible sand or sand and gravel such as that meeting Ontario Provincial Standard Specifications (OPSS) requirements for Granular B Type I. The sand backfill within the garage should be compacted in maximum 300 millimetres thick lifts to at least 95 percent of the standard Proctor dry density value using suitable vibratory compaction equipment. Alternatively, suitable water sluicing methods would be acceptable.

The backfill against isolated (unheated) walls or piers should consist of free draining, non-frost susceptible material, such as sand meeting OPSS Granular B Type I requirements. Other measures to prevent frost jacking of these foundation elements could be provided, if required.

Site Services

Excavation

Based on the available subsurface information, the excavations for the services on the site may be carried out through topsoil, fill, silty sand, sand, silty clay, glacial till and bedrock. The sides of the excavations within overburden soils should be sloped in accordance with the requirements in Ontario Regulation 213/91 under the Occupational Health and Safety Act. According to the act, the native soils at this site can be classified as; Type 2 - silty clay weathered crust and sandy soils. Therefore, for design purposes, allowance should be made for 1 horizontal to 1 vertical slopes within 1.2 metres of the bottom of the excavation in silty clay weathered crust, and 1 horizontal to 1 vertical, from the bottom of the excavation in sandy soils and glacial till.

Excavation below the groundwater level within silty sand or sand soils could present some constraints unless the groundwater is lowered in advance of excavation. There is potential for some disturbance to the soils at the bottom of the excavation and relatively flat side slopes may be required to prevent sloughing of material into the excavation. It is our experience that excavation for site service installation to shallow depth within these sandy deposits can usually be carried out within a braced steel trench box specifically designed for this purpose, in combination, where necessary, with steel plates advanced along the sides of the trench box to below the level of excavation. In this case, the groundwater inflow should be controlled throughout the excavation and pipe laying operations by pumping from sumps within the excavation. Notwithstanding, some disturbance and loosening of the subgrade materials could occur, and allowance should be made for subexcavation and additional pipe bedding (sub-bedding) material, as discussed later in this report.

Bedrock removal will likely require drill and blasting or hoe ramming techniques in combination with line drilling on close centres. Any blasting should be carried out under the supervision of a blasting specialist engineer. As a general guideline, a maximum peak particle velocity of 50 millimetres per second could be used as the vibration criteria at the nearest structure or service. It is pointed out that this criteria was established to prevent damage to existing buildings and services; more stringent criteria would be required to prevent damage to freshly placed (uncured) concrete. The bedrock at this site is very hard and therefore will cause considerable wear on hoe-ramming equipment.

Based on our experience with excavation of bedrock in this area and, provided that good blasting techniques are used, blasted rock from this area is usually fairly well graded and can be used as bulk fill beneath roadways, as sewer trench backfill and, in some instances, as engineered fill beneath lightly loaded foundations.

Pipe Bedding and Cover Materials

It is suggested that the service pipe bedding material consist of at least 150 millimetres of granular material meeting OPSS requirements for Granular A. Allowance should, however, be made for subexcavation of any existing fill, organic deposits or disturbed material encountered at subgrade level. To provide adequate support for the services pipes in the long term, the excavations should be sized to allow a 1 horizontal to 2 vertical spread of granular material down and out from the bottom of the pipes.

Granular material meeting OPSS specifications for Granular B Type II could be used as a sub-bedding material. The use of clear crushed stone as a bedding or sub-bedding material should not be permitted.

Cover material, from pipe spring line to at least 300 millimetres above the top of the pipe, should consist of granular material, such as OPSS Granular A or Granular B Type I (with a maximum particle size of 25 millimetres).

The sub-bedding, bedding and cover materials should be compacted in maximum 200 millimetre thick lifts to at least 95 percent of the standard Proctor maximum dry density using suitable vibratory compaction equipment.

Trench Backfill

The general backfilling procedures should be carried out in a manner that is compatible with the future use of the area above the service trenches.

In areas where the service trench will be located below or in close proximity to existing or future roadway areas, acceptable native materials should be used as backfill between the roadway subgrade level and the depth of seasonal frost penetration in order to reduce the potential for differential frost heaving between the area over the trench and the adjacent section of roadway. Where native backfill is used, it should match the native materials exposed on the trench walls. Backfill below the zone of seasonal frost penetration could consist of either acceptable native material or imported granular material conforming to OPSS Granular B Type I. The depth of frost penetration in areas that are kept clear of snow and where the trench backfill consists of broadly graded shattered rock fill or earth fill is expected to be about 1.8 metres. It is our experience, however, that the frost penetration can be as much as 2.4 metres when the trench backfill consists solely of relatively open graded rock fill. Where cover requirements are not practicable, the pipes could be protected from frost using a combination of earth cover and insulation. Further details regarding insulation could be provided, if required.

It is anticipated that most of the inorganic overburden materials encountered during the subsurface investigation will be acceptable for reuse as trench backfill. Topsoil and any organic material should be wasted from the trench. If on site blast rock is used as backfill within the service trench, it should be mostly 300 millimetres, or smaller, in size and should be well graded. To prevent ingress of fine material

into voids in the blast rock, the upper surface of the blast rock should be blinded with well graded crushed stone.

To minimize future settlement of the backfill and achieve an acceptable subgrade for the roadways, sidewalks, driveways, etc., the trench backfill should be compacted in maximum 300 millimetre thick lifts to at least 95 percent of the standard Proctor dry density value. Rock fill should be placed in maximum 500 millimetre thick lifts and compacted with the haulage and spreading equipment. The specified density for compaction of the backfill materials may be reduced where the trench backfill is not located below or in close proximity to existing or future areas of hard surfacing and/or structures.

Some of the silty sand, silty clay and glacial till from the lower part of the excavations will likely be wet of optimum for compaction. Furthermore, the silty sand, silty clay and glacial till overburden deposits at this site are sensitive to changes in moisture content. Unless these materials are allowed to dry, the specified densities will not likely be possible to achieve and, as a consequence, some settlement of these backfill materials could occur. Consideration could be implementing one or a combination of the following measures to reduce post construction settlement above the trenches, depending on the weather conditions encountered during the construction:

- Allow the overburden materials to dry prior to compaction;
- Reuse any wet materials in the lower part of the trenches and make provisions to differ final paving of any roadways (i.e., HL3 asphaltic concrete placement) for 3 months, or longer, to allow the trench backfill settlement to occur and thereby improve the final roadway appearance;
- Reuse any wet materials outside hard surfaced areas and where post construction settlement is less of a concern (such as landscaped areas).

The soils that exist at this site are highly frost susceptible and are prone to significant ice lensing. In order to carry out the work during freezing temperatures and maintain adequate performance of the trench backfill as a roadway subgrade, the service trenches should be opened for as short a time as practicable and the excavations should be carried out only in lengths which allow all of the construction operations, including backfilling, to be fully completed in one working day. The sides of the trenches

should not be allowed to freeze. In addition, the backfill should be excavated, stored and replaced without being disturbed by frost or contaminated by snow or ice.

Roadways

Subgrade Preparation

In preparation for roadway construction at this site, all surficial topsoil and any soft, wet or deleterious materials should be removed from the proposed roadways. Any subexcavated areas could be filled with compacted earth borrow or well shattered and graded rock fill material. Similarly, should it be necessary to raise the roadway grades at this site, material which meets OPSS specifications for Select Subgrade Material, earth borrow or well shattered and graded rock fill material may be used. The Select Subgrade Material or earth borrow should be placed in maximum 300 millimetre thick lifts and compacted to at least 95 percent of the standard Proctor maximum dry density value using vibratory compaction equipment. Rock fill should also be placed in thin lifts and suitably compacted either with a large drum roller, the haulage and spreading equipment, or a combination of both. Prior to placing granular material for the roadway, the exposed subgrade should be heavily proof rolled and inspected and approved by geotechnical personnel. Any soft areas evident from the proof rolling should be subexcavated and replaced with suitable earth borrow or rock fill approved by the geotechnical engineer.

The subgrade should be shaped and crowned to promote drainage of the roadway granular materials.

Pavement Structure

For the roadways within this residential development, the minimum standard pavement structure should be used:

80 millimetres of hot mix asphaltic concrete (40 millimetres of HL3 over 40 millimetres of HL8)

150 millimetres of OPSS Granular A base over

375 millimetres of OPSS Granular B, Type II subbase

The above Granular B Type II subbase thicknesses could be reduced to 150 millimetres (minimum) in areas where the subgrade material below the pavement consists of competent bedrock or at least 0.5

metres of clean sand or well shattered blast rock. An assessment of the subgrade conditions could be made by the geotechnical engineer at the time of construction.

The above pavement structure assumes that the trench backfill is adequately compacted and that the roadway subgrade surface is prepared as described in this report. If the roadway subgrade surface is disturbed or wetted due to construction operations or precipitation, the granular thickness given above may not be adequate and it may be necessary to increase the thickness of the Granular B Type II subbase and/or to incorporate a woven geotextile separator between the roadway subgrade surface and the granular subbase material. The adequacy of the design pavement thickness should be assessed by geotechnical personnel at the time of construction.

Granular Material Placement

The pavement granular materials should be compacted in maximum 300 millimetre thick lifts to at least 98 percent of standard Proctor maximum dry density using suitable vibratory compaction equipment.

Transition Treatments

In areas where the new pavement structure will abut existing pavements, the depths of the granular materials should taper up or down at 5 horizontal to 1 vertical, or flatter, to match the depths of the granular material(s) exposed in the existing pavement.

Pavement Drainage

The subgrade surface should be shaped and crowned to promote drainage of the roadway granular materials.

In order to provide drainage of the granular subbase, it is suggested that catch basins be provided with perforated stub drains extending about 3 metres out from the catch basins in two directions parallel to the roadway. These drains should be installed at the bottom of the subbase layer.

Construction Induced Vibration

Some of the construction operations (such as bedrock removal by blasting or hoe ramming, granular material compaction, excavation, etc.) will cause ground vibration on the site. The vibrations will attenuate with distance from the source but may be felt at nearby structures. It is suggested therefore that the scheduling of vibration causing construction operations be planned to avoid any adverse effects of such vibrations on freshly placed (uncured) concrete and on existing buildings. Pre-condition surveys should also be carried out on existing, nearby structures.

Effects of Trees on the Foundations

Based on the results of the boreholes, portions of this site are underlain by deposits of silty clay, a material which is known to be susceptible to shrinkage with a change/reduction in moisture content. Research by the Institute for Research in Construction (formerly the Division of Building Research) of the National Research Council of Canada has shown that trees can cause a reduction of moisture content in the sensitive silty clays in the Ottawa area, which can result in significant settlement/damage to nearby buildings supported on shallow foundations. Therefore, no deciduous trees should be permitted closer to the houses (or any ground supported structures which may be affected by settlement) than the ultimate height of the trees. For groups of trees or trees in rows, the separation distance should be increased to 1.5 times the ultimate height of the trees.

The effects of trees (both existing and proposed) on the dwellings should be considered in the landscape plan for this development.

CONSTRUCTION CONSIDERATIONS AND OBSERVATION

The design details for the project such as sewer depths, finished grades, foundation depths, etc. were not available at the time of this report. It is recommended, therefore, that the final design drawings for the site be reviewed by the geotechnical engineer to ensure that the guidelines provided in this report have been interpreted as intended.

The engagement of the services of the geotechnical consultant during construction is recommended to confirm that the subsurface conditions throughout the proposed development do not materially differ

from those given in the report and that the construction activities do not adversely affect the intent of the design.

The native soils at this site will be sensitive to construction operations, from ponded water and frost. The construction operations should therefore be carried out in a manner that will prevent disturbance of the subgrade surfaces.

All footing surfaces and any engineered fill areas for the residences should be inspected by Morey Houle Chevrier Engineering Ltd. to ensure that a suitable subgrade has been reached and properly prepared. The placing and compaction of granular materials beneath the foundations should be inspected to ensure that the materials used conform to the grading and compaction specifications. The subgrade surfaces for the site services and roadways should be inspected by geotechnical personnel. In situ density testing should be carried out on the service pipe bedding and backfill and the roadway granular materials.

We trust that this report is sufficient for your requirements. If you have any questions concerning this information or if we can be of further assistance to you on this project, please call.

Yours truly,

MOREY HOULE CHEVRIER ENGINEERING LTD.



B.D. Wiebe, P.Eng.



A.C. Houle, P.Eng.
Principal

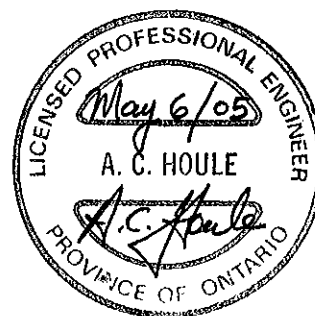

List of Abbreviations and Terminology
Bedrock Description Terminology
Record of Borehole Sheets
Figures 1 and 2

LIST OF ABBREVIATIONS AND TERMINOLOGY

SAMPLE TYPES

AS	auger sample
CS	chunk sample
DO	drive open
MS	manual sample
RC	rock core
ST	slotted tube
TO	thin-walled open Shelby tube
TP	thin-walled piston Shelby tube
WS	wash sample

SOIL DESCRIPTIONS

<u>Relative Density</u>	<u>'N' Value</u>
Very Loose	0 to 4
Loose	4 to 10
Compact	10 to 30
Dense	30 to 50
Very Dense	over 50

PENETRATION RESISTANCE

Standard Penetration Resistance, N

The number of blows by a 63.5 kg hammer dropped 760 millimetres required to drive a 50 mm drive open sampler for a distance of 300 mm. For split spoon samples where less than 300 mm of penetration was achieved, the number of blows is reported over the sampler penetration in mm.

Dynamic Penetration Resistance

The number of blows by a 63.5 kg hammer dropped 760 mm to drive a 50 mm diameter, 60° cone attached to 'A' size drill rods for a distance of 300 mm.

WH

Sampler advanced by static weight of hammer and drill rods.

WR

Sampler advanced by static weight of drill rods.

PH

Sampler advanced by hydraulic pressure from drill rig.

PM

Sampler advanced by manual pressure.

<u>Consistency</u>	<u>Undrained Shear Strength (kPa)</u>
--------------------	---------------------------------------

Very soft	0 to 12
Soft	12 to 25
Firm	25 to 50
Stiff	50 to 100
Very Stiff	over 100

LIST OF COMMON SYMBOLS

c_u	undrained shear strength
e	void ratio
C_c	compression index
c_v	coefficient of consolidation
k	coefficient of permeability
I_p	plasticity index
n	porosity
u	pore pressure
w	moisture content
w_L	liquid limit
w_p	plastic limit
ϕ^1	effective angle of friction
γ	unit weight of soil
γ^1	unit weight of submerged soil
σ	normal stress

SOIL TESTS

C	consolidation test
H	hydrometer analysis
M	sieve analysis
MH	sieve and hydrometer analysis
U	unconfined compression test
Q	undrained triaxial test
V	field vane, undisturbed and remoulded shear strength

BEDROCK DESCRIPTION TERMINOLOGY

STATE OF WEATHERING

Fresh: no visible sign of weathering.

Faintly weathered: weathering limited to the surfaces of major discontinuities.

Slightly weathered: penetrative weathering developed on open discontinuity surfaces but only slight weathering of rock material.

Moderately weathered: weathering extends throughout the rock mass, but the rock material is not friable.

Highly weathered: weathering extends throughout the rock mass and the rock material is partly friable.

Completely weathered: rock is wholly decomposed and in a friable condition but the rock texture and structure are preserved.

BEDDING THICKNESS

<u>Description</u>	<u>Bedding Plane Spacing</u>
Very thickly bedded	> 2 m
Thickly bedded	0.6 m to 2 m
Medium bedded	0.2 m to 0.6 m
Thinly bedded	60 mm to 0.2 m
Very thinly bedded	20 mm to 60 mm
Laminated	6 mm to 20 mm
Thinly laminated	< 6 mm

CORE CONDITION

Total Core Recovery (TCR): The percentage of solid drill core recovered regardless of quality or length, measured relative to the length of the total core run.

Solid Core Recovery (SCR): The percentage of solid drill core, regardless of length, recovered at full diameter, measured relative to the length of the total core run.

Rock Quality Designation (RQD): The percentage of solid drill core, greater than 100 mm in length, recovered at full diameter, measured relative to the length of the total core run. RQD varies from 0% for completely broken core to 100% for core in solid sticks.

PROJECT: 05-068

RECORD OF BOREHOLE 1

SHEET 1 OF 1

LOCATION: Refer to Site Plan, Figure 2

DATUM: Geodetic

BORING DATE: April 11, 2005

SPT HAMMER: 63.6 kg; drop 0.76 m

DEPTH SCALE METRES	BORING METHOD	SOIL PROFILE		SAMPLES			DYNAMIC PENETRATION RESISTANCE, BLOWS/0.3m				HYDRAULIC CONDUCTIVITY, k, cm/s				ADDITIONAL LAB. TESTING	PIEZOMETER OR STANDPIPE INSTALLATION	
		DESCRIPTION	STRATA PLOT	ELEV. DEPTH (m)	NUMBER	TYPE	BLOWS/0.3m	20	40	60	80	10 ⁻⁷	10 ⁻⁶	10 ⁻⁵			10 ⁻⁴
0	Power Auger 200 mm Diameter Hollow Stem	Ground Surface		87.12													
		TOPSOIL		87.02													
		Very stiff to stiff grey brown SILTY CLAY, weathered crust		0.10													
1					1	50 DO	26										
2					2	50 DO	23										
3		Loose grey brown silty sand, some gravel, cobbles and boulders (GLACIAL TILL)		84.38													
				2.74													
				3	50 DO	18											
4		Practical refusal to excavating on probable BEDROCK End of borehole		83.77													
				3.35													
5				4	50 DO	5											

Groundwater conditions not observed.

DEPTH SCALE

1 to 25

Morey Houle Chevrier Engineering Ltd.

LOGGED: BW

CHECKED: *ACH*

BOREHOLE RECORD 05-068.GPJ MHECL.GDT 5/5/05

PROJECT: 05-068

RECORD OF BOREHOLE 2

SHEET 1 OF 1

LOCATION: Refer to Site Plan, Figure 2

DATUM: Geodetic

BORING DATE: April 11, 2005

SPT HAMMER: 63.6 kg; drop 0.76 m

DEPTH SCALE METRES	BORING METHOD	SOIL PROFILE		SAMPLES		DYNAMIC PENETRATION RESISTANCE, BLOWS/0.3m				HYDRAULIC CONDUCTIVITY, k, cm/s				ADDITIONAL LAB. TESTING	PIEZOMETER OR STANDPIPE INSTALLATION
		DESCRIPTION	STRATA PLOT	ELEV. DEPTH (m)	NUMBER	TYPE	BLOWS/0.3m	SHEAR STRENGTH		WATER CONTENT, PERCENT		WATER CONTENT, PERCENT			
								20	40	60	80	nat. V - + Q - ●	rem. V - ⊕ U - ○		
0	Power Auger 200 mm Diameter Hollow Stem	Ground Surface		87.43											
		TOPSOIL		87.33											
		Very stiff to stiff grey brown SILTY CLAY, weathered crust		0.10											
1		Gray brown silty sand, some gravel, cobbles and boulders (GLACIAL TILL)		86.43 1.00	1	50 DO	12								
		Practical refusal to excavating on probable BEDROCK End of borehole		86.21 1.22											
2															
3															
4															
5															

Groundwater conditions not observed.

BOREHOLE RECORD 05-068.GPJ MHECL.GDT 5/5/05

DEPTH SCALE

1 to 25

Morey Houle Chevrier Engineering Ltd.

LOGGED: BW

CHECKED: *ACK*

PROJECT: 05-068

RECORD OF BOREHOLE 3

SHEET 1 OF 1

LOCATION: Refer to Site Plan, Figure 2

DATUM: Geodetic

BORING DATE: April 11, 2005

SPT HAMMER: 63.6 kg; drop 0.76 m

DEPTH SCALE METRES	BORING METHOD	SOIL PROFILE		SAMPLES		DYNAMIC PENETRATION RESISTANCE, BLOWS/0.3m				HYDRAULIC CONDUCTIVITY, k, cm/s				ADDITIONAL LAB. TESTING	PIEZOMETER OR STANDPIPE INSTALLATION
		DESCRIPTION	STRATA PLOT	ELEV. DEPTH (m)	NUMBER	TYPE	BLOWS/0.3m	SHEAR STRENGTH		WATER CONTENT, PERCENT					
								Cu, kPa	nat. V - rem. V -	+ -	Q - U -	Wp	W		
0	Power Auger 200 mm Diameter Hollow Stem	Ground Surface		87.36											
		TOPSOIL		87.28											
		Grey brown SILTY SAND, some gravel		0.10											
		Very stiff to stiff grey brown SILTY CLAY, weathered crust		87.00											
				0.36											
1					1	50 DO	24								
2					2	50 DO	20								
3					3	50 DO	13								
4					4	50 DO	9								
		Stiff to firm grey SILTY CLAY		83.40											
				3.96											
					5	50 DO	3								
5		End of borehole		82.33											
				5.03											

Groundwater conditions not observed.

BOREHOLE RECORD 05-068.GPJ MHECL.GDT 5/5/05

DEPTH SCALE
1 to 30

Morey Houle Chevrier Engineering Ltd.

LOGGED: BW
CHECKED: *ACH*

PROJECT: 05-068

RECORD OF BOREHOLE 4

SHEET 1 OF 1

LOCATION: Refer to Site Plan, Figure 2

DATUM: Geodetic

BORING DATE: April 8, 2005

SPT HAMMER: 63.6 kg; drop 0.76 m

DEPTH SCALE METRES	BORING METHOD	SOIL PROFILE		SAMPLES		DYNAMIC PENETRATION RESISTANCE, BLOWS/0.3m				HYDRAULIC CONDUCTIVITY, k, cm/s				ADDITIONAL LAB. TESTING	PIEZOMETER OR STANDPIPE INSTALLATION	
		DESCRIPTION	STRATA PLOT	ELEV. DEPTH (m)	NUMBER	TYPE	BLOWS/0.3m	SHEAR STRENGTH Cu, kPa		WATER CONTENT, PERCENT						
								20	40	60	80	10 ⁻⁷	10 ⁻⁶			10 ⁻⁵
0	Power Auger 200 mm Diameter Hollow Stem	Ground Surface		87.14												
		TOPSOIL		86.89 0.25												
		Very stiff to stiff grey brown SILTY CLAY, weathered crust														
1		1	50 DO	16												
		2	50 DO	11												
2																
	3	50 DO	5													
3																
	4	50 DO	2													
4		Stiff to firm grey SILTY CLAY		83.48 3.66			⊕		+							
							⊕		+							
5																
	5	50 DO	PH													
6		End of borehole		81.96 5.18												

Groundwater conditions not observed.

BOREHOLE RECORD 05-068.GPJ MHECL.GPT 5/5/05

DEPTH SCALE

1 to 30

Morey Houle Chevrier Engineering Ltd.

LOGGED: BW

CHECKED: *ACB*

PROJECT: 05-068

RECORD OF BOREHOLE 5

SHEET 1 OF 1

LOCATION: Refer to Site Plan, Figure 2

DATUM: Geodetic

BORING DATE: April 11, 2005

SPT HAMMER: 63.6 kg; drop 0.76 m

DEPTH SCALE METRES	BORING METHOD	SOIL PROFILE		SAMPLES			DYNAMIC PENETRATION RESISTANCE, BLOWS/0.3m				HYDRAULIC CONDUCTIVITY, k, cm/s				ADDITIONAL LAB. TESTING	PIEZOMETER OR STANDPIPE INSTALLATION	
		DESCRIPTION	STRATA PLOT	ELEV. DEPTH (m)	NUMBER	TYPE	BLOWS/0.3m	SHEAR STRENGTH Cu, kPa		WATER CONTENT, PERCENT							
								20	40	60	80	10 ⁻⁷	10 ⁻⁶	10 ⁻⁵			10 ⁻⁴
0	Power Auger 200 mm Diameter Hollow Stem	Ground Surface		89.49													
		TOPSOIL		89.34													
		Grey brown SILTY CLAY, weathered crust		0.15													
		Loose grey brown SILTY SAND, some gravel		0.46													
1						1	50 DO	10									
2						2	50 DO	5									
		Very stiff to stiff grey brown SILTY CLAY, weathered crust		1.98													
3					3	50 DO	21										
4					4	50 DO	13										
					5	50 DO	10	⊕		+							
					6	50 DO	10	⊕									
5					7	50 DO	5										
		Grey brown silty sand, some gravel, cobbles and boulders (GLACIAL TILL)		84.23													
		Practical refusal to excavating on probable BEDROCK		5.28													
		End of borehole		5.41													

Groundwater conditions not observed.

BOREHOLE RECORD 05-068.GPJ MHECL.GDT 5/5/05

DEPTH SCALE
1 to 30

Morey Houle Chevrier Engineering Ltd.

LOGGED: BW
CHECKED: *ACH*

PROJECT: 05-068

RECORD OF BOREHOLE 6

SHEET 1 OF 1

LOCATION: Refer to Site Plan, Figure 2

DATUM: Geodetic

BORING DATE: April 11, 2005

SPT HAMMER: 63.6 kg; drop 0.76 m

DEPTH SCALE METRES	BORING METHOD	SOIL PROFILE		SAMPLES			DYNAMIC PENETRATION RESISTANCE, BLOWS/0.3m				HYDRAULIC CONDUCTIVITY, k, cm/s				ADDITIONAL LAB. TESTING	PIEZOMETER OR STANDPIPE INSTALLATION	
		DESCRIPTION	STRATA PLOT	ELEV. DEPTH (m)	NUMBER	TYPE	BLOWS/0.3m	SHEAR STRENGTH				WATER CONTENT, PERCENT					
								Cu, kPa		nat. V - + rem. V - ⊕		Q - ● U - ○		Wp			W
0		Ground Surface		90.32													
		TOPSOIL		90.17													
		Grey brown CLAYEY SILT, some gravel and cobbles		89.79													
		Compact grey brown fine to coarse SAND, some silt and gravel		89.80	1	50 DO	12										
		Very stiff to stiff grey brown SILTY CLAY, weathered crust		88.80	2	50 DO	15										
					3	50 DO	17										
					4	50 DO	14										
					5	50 DO	11										
					6	50 DO	8										
		End of borehole		85.14													

Groundwater conditions not observed.

BOREHOLE RECORD 05-068.GPJ MHECL.GDT 5/5/05

DEPTH SCALE

1 to 30

Morey Houle Chevrier Engineering Ltd.

LOGGED: BW

CHECKED: *ACH*

PROJECT: 05-068

RECORD OF BOREHOLE 7

SHEET 1 OF 1

LOCATION: Refer to Site Plan, Figure 2

DATUM: Geodetic

BORING DATE: April 7, 2005

SPT HAMMER: 63.6 kg; drop 0.76 m

DEPTH SCALE METRES	BORING METHOD	SOIL PROFILE		SAMPLES		DYNAMIC PENETRATION RESISTANCE, BLOWS/0.3m				HYDRAULIC CONDUCTIVITY, k, cm/s				ADDITIONAL LAB. TESTING	PIEZOMETER OR STANDPIPE INSTALLATION		
		DESCRIPTION	STRATA PLOT	ELEV. DEPTH (m)	NUMBER	TYPE	BLOWS/0.3m	SHEAR STRENGTH				WATER CONTENT, PERCENT					
								Cu, kPa		Q, kPa		Wp				Wi	
0		Ground Surface TOPSOIL		91.27													
		Very stiff to stiff grey brown SILTY CLAY, weathered crust		90.85													
1					1	50 DO	10										
2	Power Auger 200 mm Diameter Hollow Stem			89.44	2	50 DO	19										
		Compact grey brown silty sand, some gravel, cobbles and boulders (GLACIAL TILL)		1.83													
3					3	50 DO	26										
					4	50 DO	22										
4				87.28	5	50 DO	3										
		Practical refusal to excavating on probable BEDROCK End of borehole		3.99													
5																	

Groundwater conditions not observed.

BOREHOLE RECORD_05-068.GPJ_MHECL_GDT_5/5/05

DEPTH SCALE

1 to 25

Morey Houle Chevrier Engineering Ltd.

LOGGED: BW

CHECKED: *ACF*

PROJECT: 05-068

RECORD OF BOREHOLE 8

SHEET 1 OF 1

LOCATION: Refer to Site Plan, Figure 2

DATUM: Geodetic

BORING DATE: April 11, 2005

SPT HAMMER: 63.6 kg; drop 0.76 m

DEPTH SCALE METRES	BORING METHOD	SOIL PROFILE		SAMPLES		DYNAMIC PENETRATION RESISTANCE, BLOWS/0.3m				HYDRAULIC CONDUCTIVITY, k, cm/s				ADDITIONAL LAB. TESTING	PIEZOMETER OR STANDPIPE INSTALLATION		
		DESCRIPTION	STRATA PLOT	ELEV. DEPTH (m)	NUMBER	TYPE	BLOWS/0.3m	SHEAR STRENGTH				WATER CONTENT, PERCENT					
								Cu, kPa		nat. V - + rem. V - ⊕ Q - ● U - ○		Wp				W	
0	Power Auger 200 mm Diameter Hollow Stem	Ground Surface		91.36													
		Grey brown silty sand and clayey silt, some boulders, metal wire and brick (FILL MATERIAL)															
		Very stiff to stiff grey brown SILTY CLAY, weathered crust			90.85 0.51												
1						1	50 DO	13									
						2	50 DO	15									
2																	
		Compact grey brown silty sand, some gravel, cobbles and boulders (GLACIAL TILL)		88.85 2.51													
3					3	50 DO	15										
4		Practical refusal to excavating on probable BEDROCK End of borehole		87.55 3.81													
					4	50 DO	25										
					5	50 DO	8										
5																	

Groundwater conditions not observed.

BOREHOLE RECORD 05-068.GPJ MHECL.GDT 5/5/05

DEPTH SCALE

1 to 25

Morey Houle Chevrier Engineering Ltd.

LOGGED: BW

CHECKED: *ACA*

PROJECT: 05-068

RECORD OF BOREHOLE 9

SHEET 1 OF 1

LOCATION: Refer to Site Plan, Figure 2

DATUM: Geodetic

BORING DATE: April 7, 2005

SPT HAMMER: 63.6 kg; drop 0.76 m

DEPTH SCALE METRES	BORING METHOD	SOIL PROFILE		SAMPLES			DYNAMIC PENETRATION RESISTANCE, BLOWS/0.3m				HYDRAULIC CONDUCTIVITY, k, cm/s				ADDITIONAL LAB. TESTING	PIEZOMETER OR STANDPIPE INSTALLATION	
		DESCRIPTION	STRATA PLOT	ELEV. DEPTH (m)	NUMBER	TYPE	BLOWS/0.3m	SHEAR STRENGTH				WATER CONTENT, PERCENT					
								Cu, kPa		nat. V - + Q - ● rem. V - ⊕ U - ○		Wp		W			Wi
0	Power Auger 200 mm Diameter Hollow Stem	Ground Surface		91.45													
		TOPSOIL		0.05													
		Grey brown SILTY CLAY, weathered crust		91.20 0.25													
		Grey brown silty sand, some gravel, cobbles and boulders (GLACIAL TILL)															
1		Practical refusal to excavating on probable BEDROCK End of borehole		90.54 0.91	1	50 DO	5									Groundwater inflow near ground surface on April 7, 2005.	
2																	
3																	
4																	
5																	

BOREHOLE RECORD 05-068.GPJ MHECL_GDT 5/5/05

DEPTH SCALE

1 to 25

Morey Houle Chevrier Engineering Ltd.

LOGGED: BW

CHECKED: *ACF*

PROJECT: 05-068

RECORD OF BOREHOLE 11

SHEET 1 OF 1

LOCATION: Refer to Site Plan, Figure 2

DATUM: Geodetic

BORING DATE: April 8, 2005

SPT HAMMER: 63.6 kg; drop 0.76 m

DEPTH SCALE METRES	BORING METHOD	SOIL PROFILE		SAMPLES		DYNAMIC PENETRATION RESISTANCE, BLOWS/0.3m				HYDRAULIC CONDUCTIVITY, k, cm/s				ADDITIONAL LAB. TESTING	PIEZOMETER OR STANDPIPE INSTALLATION
		DESCRIPTION	STRATA PLOT	ELEV. DEPTH (m)	NUMBER	TYPE	BLOWS/0.3m	SHEAR STRENGTH Cu, kPa		WATER CONTENT, PERCENT					
								20	40	60	80	20	40		
0	Power Auger 200 mm Diameter Hollow Stem	Ground Surface		88.30											
		TOPSOIL		88.00											
		Loose to compact grey brown silty sand, some gravel, cobbles and boulders (GLACIAL TILL)		0.30											
1					1	50 DO	11								
2					2	50 DO	9								
3					3	50 DO	14								
		Practical refusal to excavating on probable BEDROCK End of borehole		85.48 2.82											Groundwater conditions not observed.
4															
5															

BOREHOLE RECORD 05-068.GPJ MHECL_GDT 5/5/05

DEPTH SCALE

1 to 25

Morey Houle Chevrier Engineering Ltd.

LOGGED: BW

CHECKED: *ACA*

PROJECT: 05-068

RECORD OF BOREHOLE 12

SHEET 1 OF 1

LOCATION: Refer to Site Plan, Figure 2

DATUM: Geodetic

BORING DATE: April 8, 2005

SPT HAMMER: 63.6 kg; drop 0.76 m

DEPTH SCALE METRES	BORING METHOD	SOIL PROFILE		SAMPLES			DYNAMIC PENETRATION RESISTANCE, BLOWS/0.3m				HYDRAULIC CONDUCTIVITY, k, cm/s				ADDITIONAL LAB. TESTING	PIEZOMETER OR STANDPIPE INSTALLATION	
		DESCRIPTION	STRATA PLOT	ELEV. DEPTH (m)	NUMBER	TYPE	BLOWS/0.3m	SHEAR STRENGTH				WATER CONTENT, PERCENT					
								Cu, kPa		nat. V - + Q - ● rem. V - ⊕ U - ○		Wp		W			
0	Power Auger 200 mm Diameter Hollow Stem	Ground Surface		86.80													
		TOPSOIL		86.67 0.13													
		Very stiff to stiff grey brown SILTY CLAY, weathered crust															
1					1	50 DO	12										
2					2	50 DO	18										
3				84.34 2.46 2.51	3	50 DO	7										
		Grey brown silty sand, some gravel, cobbles and boulders (GLACIAL TILL) Practical refusal to excavating on probable BEDROCK End of borehole															
4																	
5																	

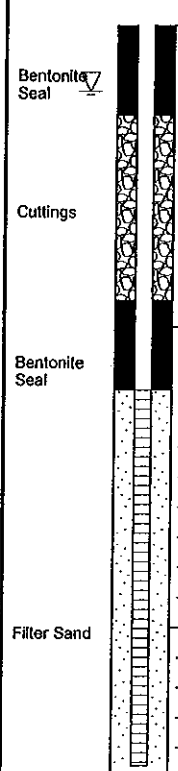

BOREHOLE RECORD 05-068.GPJ MHECL_GDT 5/5/05

DEPTH SCALE
1 to 25

Morey Houle Chevrier Engineering Ltd.

LOGGED: BW
CHECKED: *ACH*

PROJECT: 05-068

RECORD OF BOREHOLE 12 A

SHEET 1 OF 1

LOCATION: 2 metres south of BH 12

DATUM: Geodetic

BORING DATE: April 11, 2005

SPT HAMMER: 63.6 kg; drop 0.76 m

DEPTH SCALE METRES	BORING METHOD	SOIL PROFILE		SAMPLES		DYNAMIC PENETRATION RESISTANCE, BLOWS/0.3m				HYDRAULIC CONDUCTIVITY, k, cm/s				ADDITIONAL LAB. TESTING	PIEZOMETER OR STANDPIPE INSTALLATION
		DESCRIPTION	STRATA PLOT	ELEV. DEPTH (m)	NUMBER	TYPE	BLOWS/0.3m	SHEAR STRENGTH Cu, kPa		WATER CONTENT, PERCENT					
								20	40	60	80	10 ⁻⁷	10 ⁻⁶		
0	Casing	Ground Surface		86.80											
		OVERBURDEN													
1															
2															
		Fresh to faintly weathered amphibolite BEDROCK		84.67 2.13											
3					R.C.										
						TCR = 100%	SCR = 80%	RQD = 80%							
		End of corehole		83.09 3.71											
4															
															Groundwater conditions not observed.
5															

BOREHOLE RECORD 05-068.GPJ MHECL.GDT 5/5/05

DEPTH SCALE

1 to 25

Morey Houle Chevrier Engineering Ltd.

LOGGED: BW

CHECKED: *ACH*

PROJECT: 05-068

RECORD OF BOREHOLE 13

SHEET 1 OF 1

LOCATION: Refer to Site Plan, Figure 2

DATUM: Geodetic

BORING DATE: April 8, 2005

SPT HAMMER: 63.6 kg; drop 0.76 m

DEPTH SCALE METRES	BORING METHOD	SOIL PROFILE		SAMPLES		DYNAMIC PENETRATION RESISTANCE, BLOWS/0.3m				HYDRAULIC CONDUCTIVITY, k, cm/s				ADDITIONAL LAB. TESTING	PIEZOMETER OR STANDPIPE INSTALLATION		
		DESCRIPTION	STRATA PLOT	ELEV. DEPTH (m)	NUMBER	TYPE	BLOWS/0.3m	SHEAR STRENGTH				WATER CONTENT, PERCENT					
								Cu, kPa		nat. V - + Q - ● rem. V - ⊕ U - ○		Wp				W	
0	Power Auger 200 mm Diameter Hollow Stem	Ground Surface		86.41													
		TOPSOIL		86.11													
		Very stiff to stiff grey brown SILTY CLAY, weathered crust		0.30													
1					1	50 DO	7										
2					2	50 DO	11										
3					3	50 DO	9										
4			Firm grey SILTY CLAY		82.75												
				3.66													
5																	
6		End of borehole		80.62													
				5.79													
7																	
8																	

Groundwater conditions not observed.

BOREHOLE RECORD 05-068.GPJ MHECI.GDT 5/5/05

DEPTH SCALE

1 to 40

Morey Houle Chevrier Engineering Ltd.

LOGGED: BW

CHECKED: *ACH*

PROJECT: 05-068

RECORD OF BOREHOLE 14

SHEET 1 OF 1

LOCATION: Refer to Site Plan, Figure 2

DATUM: Geodetic

BORING DATE: April 8, 2005

SPT HAMMER: 63.6 kg; drop 0.76 m

DEPTH SCALE METRES	BORING METHOD	SOIL PROFILE		SAMPLES		DYNAMIC PENETRATION RESISTANCE, BLOWS/0.3m				HYDRAULIC CONDUCTIVITY, k, cm/s				ADDITIONAL LAB. TESTING	PIEZOMETER OR STANDPIPE INSTALLATION
		DESCRIPTION	STRATA PLOT	ELEV. DEPTH (m)	NUMBER	TYPE	BLOWS/0.3m	SHEAR STRENGTH Cu, kPa		WATER CONTENT, PERCENT					
								20	40	60	80	10 ⁻⁷	10 ⁻⁶		
0	Power Auger 200 mm Diameter Hollow Stem	Ground Surface		86.54											
		Grey brown silty clay FILL MATERIAL		86.41											
		FORMER TOPSOIL		0.13											
		Very stiff to stiff grey brown SILTY CLAY, weathered crust		0.23											
1						1	50 DO	9							
2						2	50 DO	6							
3						3	50 DO	3							
4						4	50 DO	5							
4			Stiff grey SILTY CLAY		82.73 3.81	5	50 DO	3							
5						6	50 DO	2							
6		End of borehole		80.75 5.79											

Groundwater conditions not observed.

BOREHOLE RECORD 05-068.GPJ MHECL.GDT 5/5/05

DEPTH SCALE

1 to 40

Morey Houle Chevrier Engineering Ltd.

LOGGED: BW

CHECKED: *ACH*

PROJECT: 05-068

RECORD OF BOREHOLE 15

SHEET 1 OF 1

LOCATION: Refer to Site Plan, Figure 2

DATUM: Geodetic

BORING DATE: April 8, 2005

SPT HAMMER: 63.6 kg; drop 0.76 m

DEPTH SCALE METRES	BORING METHOD	SOIL PROFILE		SAMPLES		DYNAMIC PENETRATION RESISTANCE, BLOWS/0.3m				HYDRAULIC CONDUCTIVITY, k, cm/s				ADDITIONAL LAB. TESTING	PIEZOMETER OR STANDPIPE INSTALLATION		
		DESCRIPTION	STRATA PLOT	ELEV. DEPTH (m)	NUMBER	TYPE	BLOWS/0.3m	SHEAR STRENGTH Cu, kPa		WATER CONTENT, PERCENT							
								20	40	60	80	20	40			60	80
0	Power Auger 200 mm Diameter Hollow Stem	Ground Surface		87.16													
		TOPSOIL		87.06													
		Very stiff to stiff grey brown SILTY CLAY, weathered crust		0.10													
1		1	50 DO	8													
2		2	50 DO	13													
3		3	50 DO	11													
3		4	50 DO	7													
4	5	50 DO	6														
5	6	50 DO	4														
5	7	50 DO	2														
6		End of borehole		81.37													
				3.05													
				3.79													

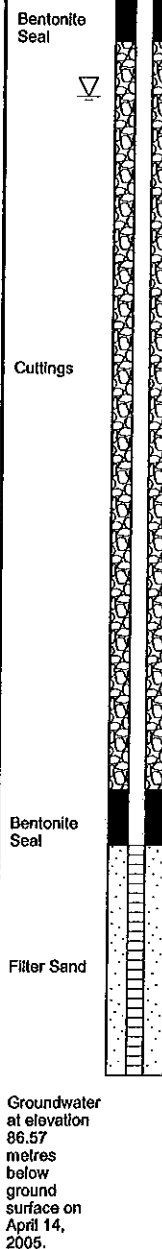

BOREHOLE RECORD 05-068.GPJ MHECL.GDT 5/5/05

DEPTH SCALE

1 to 40

Morey Houle Chevrier Engineering Ltd.

LOGGED: BW

CHECKED: *ACF*

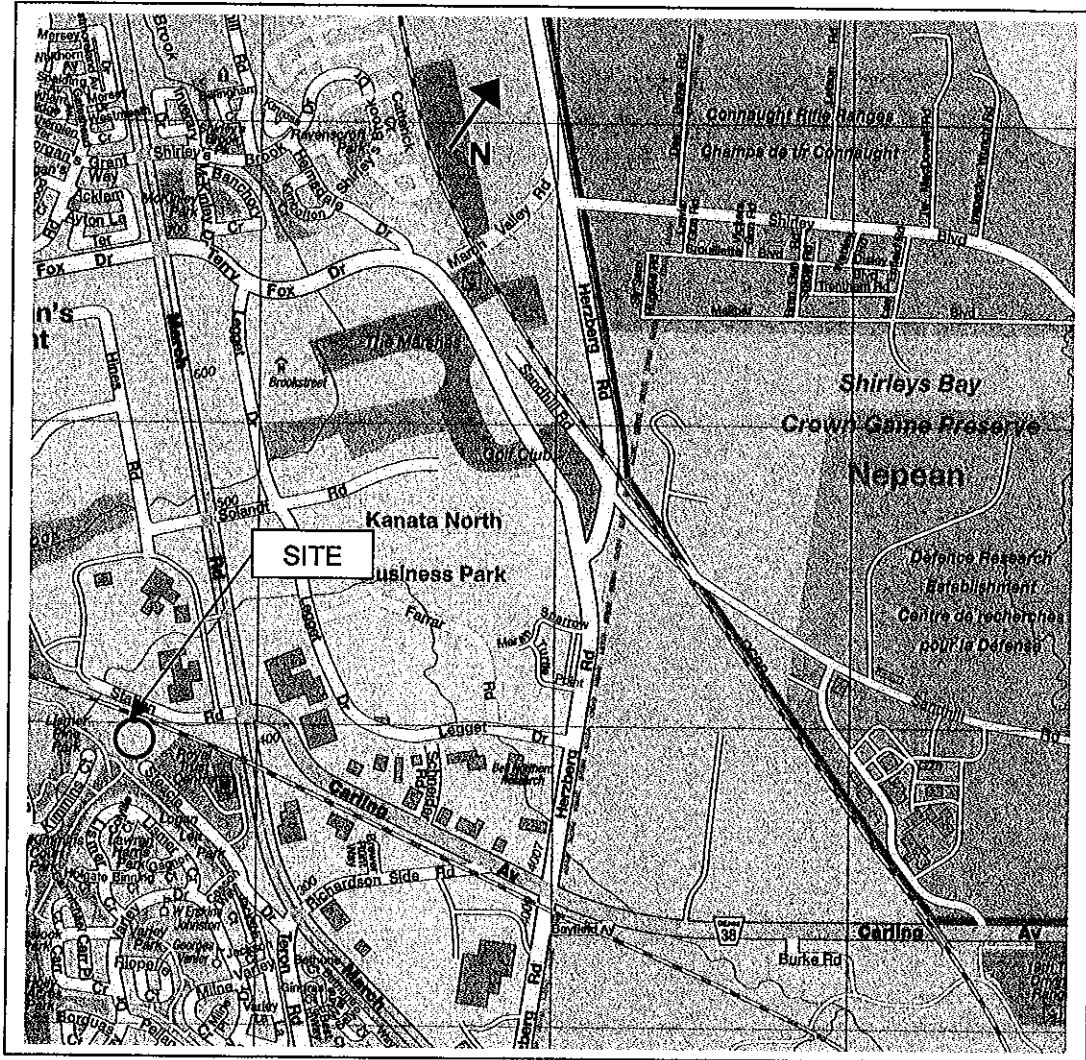

SCALE
1: 25, 000



MOREY
HOULE
CHEVRIER
ENGINEERING LTD.

Date: April 2005

Project: 05-068