

**APPROVED**  
 By *seignyo* at 4:22 pm, Jan 22, 2025

**JOHN SEIGNY C.E.T.**  
**MANAGER (A), DEVELOPMENT REVIEW EAST**  
**PLANNING, DEVELOPMENT & BUILDING SERVICES**  
**DEPARTMENT, CITY OF OTTAWA**

**GENERAL AND INTERPRETATION OF DRAWINGS**

GENERAL CONDITIONS OF THE CONTRACT FOR CONSTRUCTION ARE PART OF THE CONTRACT DOCUMENTS AND DESCRIBE WORK AND INTENT OF THE DRAWINGS. THE CONTRACTOR SHALL BE RESPONSIBLE FOR OBTAINING ALL NECESSARY PERMITS AND APPROVALS FROM THE CITY OF OTTAWA. THE CONTRACTOR SHALL BE RESPONSIBLE FOR OBTAINING ALL NECESSARY PERMITS AND APPROVALS FROM THE CITY OF OTTAWA. THE CONTRACTOR SHALL BE RESPONSIBLE FOR OBTAINING ALL NECESSARY PERMITS AND APPROVALS FROM THE CITY OF OTTAWA.

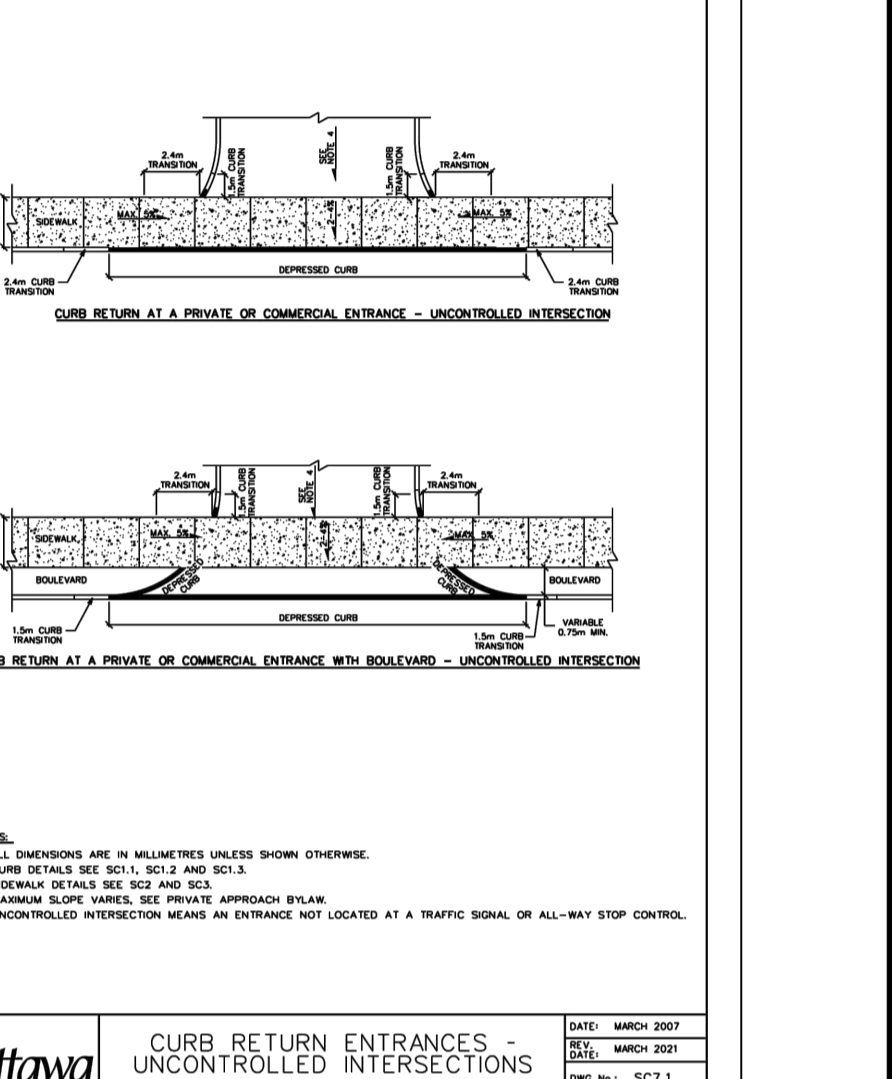
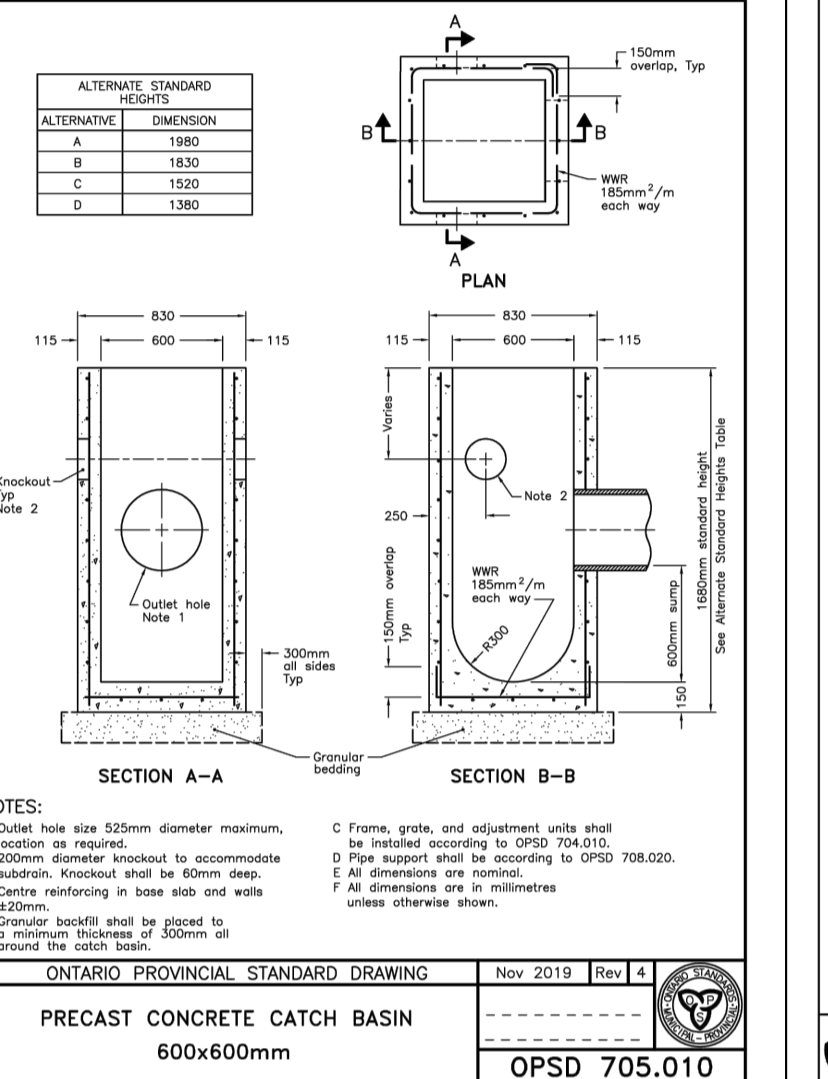
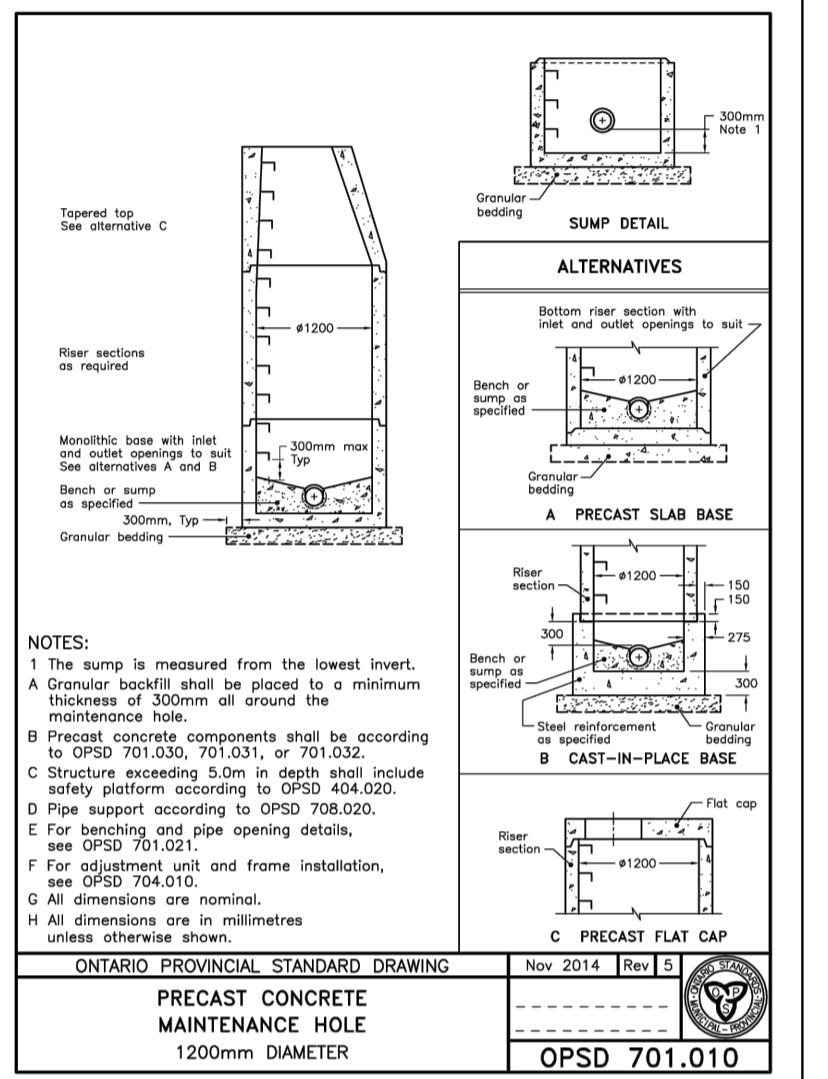
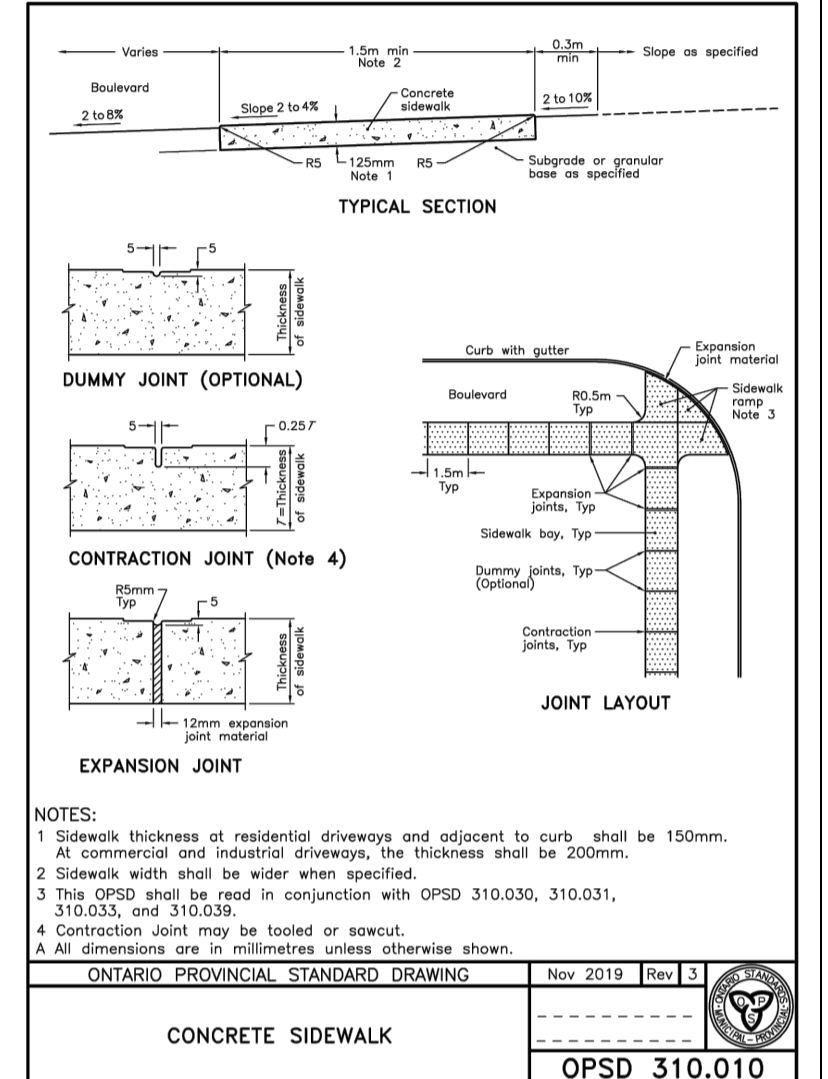
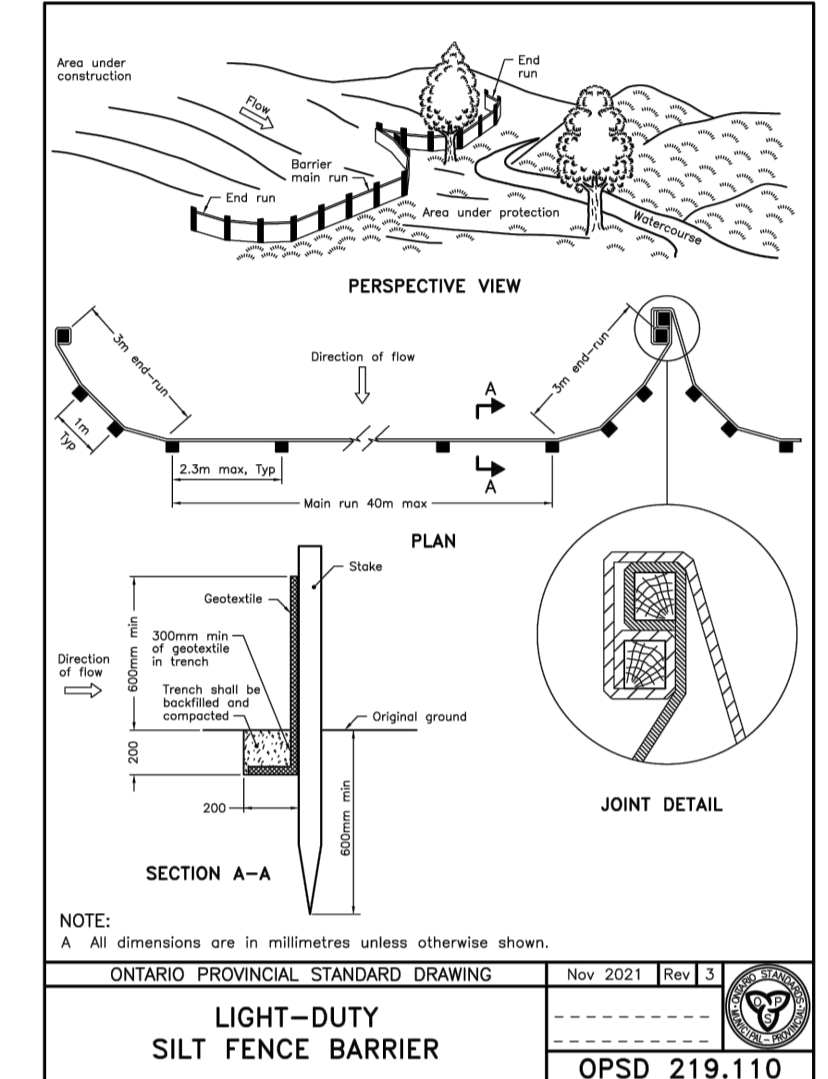
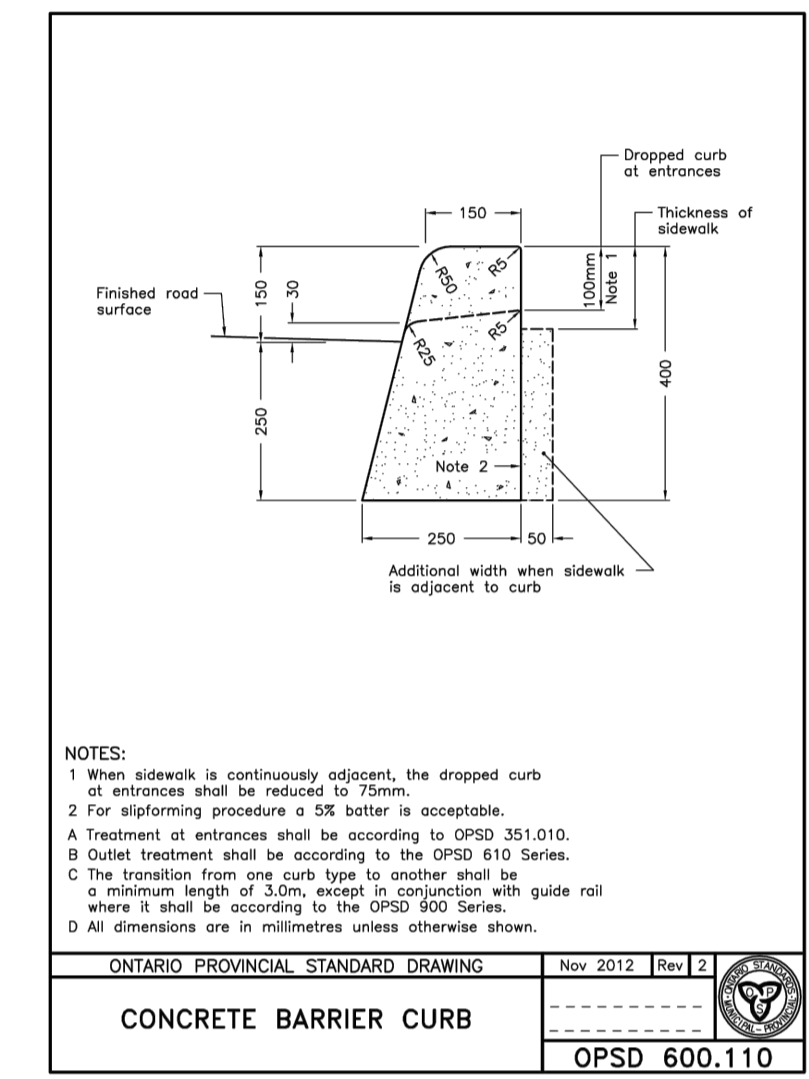

**SUBJECT FOR APPROVAL**

**GENERAL NOTES:**  
 EXISTING SERVICES AND UTILITIES SHOWN ON THESE DRAWINGS ARE TAKEN FROM THE BEST AVAILABLE RECORDS, BUT MAY NOT BE COMPLETE OR TO DATE. CONTRACTOR SHALL VERIFY IN FIELD FOR LOCATION AND ELEVATION OF PIPES AND CHECK WITH THE UTILITY COMPANIES BEFORE DIGGING OR PERFORMING WORK.  
 CONTRACTOR IS ADVISED TO COLLECT INFORMATION ON SOIL CONDITIONS BEFORE START OF CONSTRUCTION.  
 THE ENGINEER WAIVES ANY AND ALL RESPONSIBILITY AND LIABILITY FOR PROBLEMS WHICH ARISE FROM FAILURE TO FOLLOW THESE PLANS, SPECIFICATIONS AND THE DESIGN INTENT. THE CLIENT SHALL ASSUME FULL RESPONSIBILITY FOR THE RESULTS OF SUCH CHANGES. THEREFORE THE CLIENT AGREES TO WAIVE ANY CLAIM AGAINST LRL AND TO RELEASE LRL FROM ANY LIABILITY ARISING DIRECTLY OR INDIRECTLY FROM SUCH UNAUTHORIZED CHANGES.

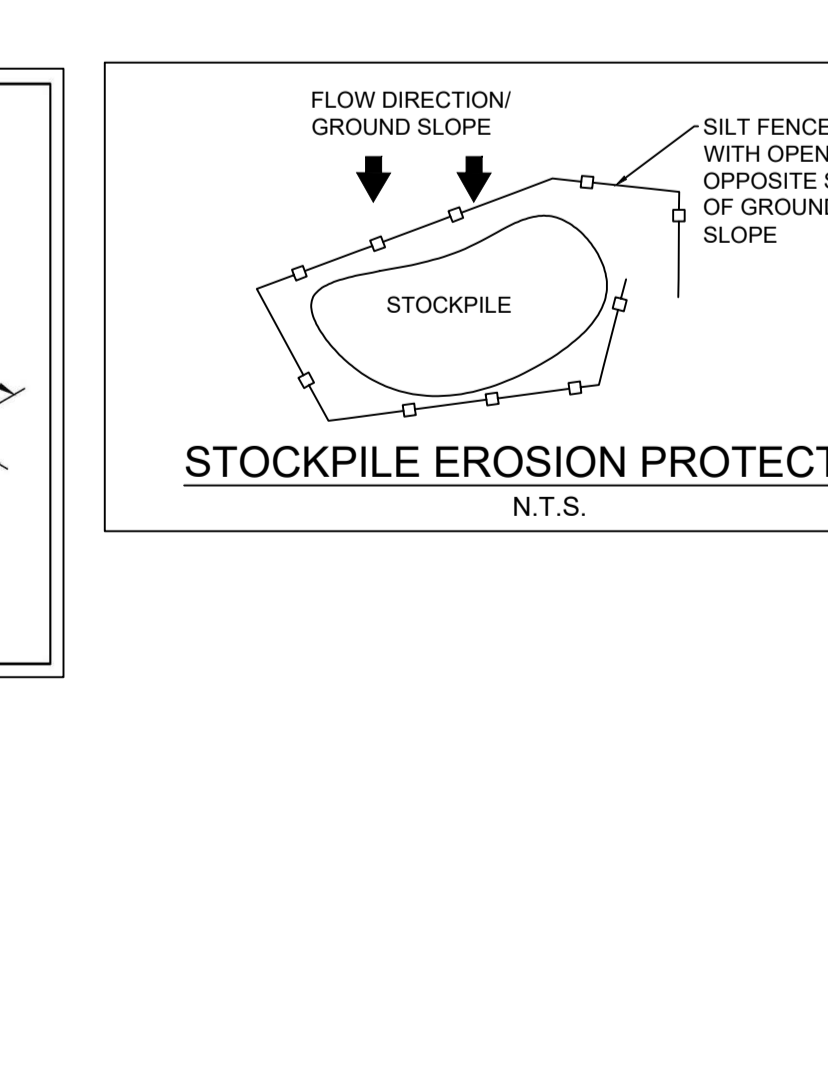
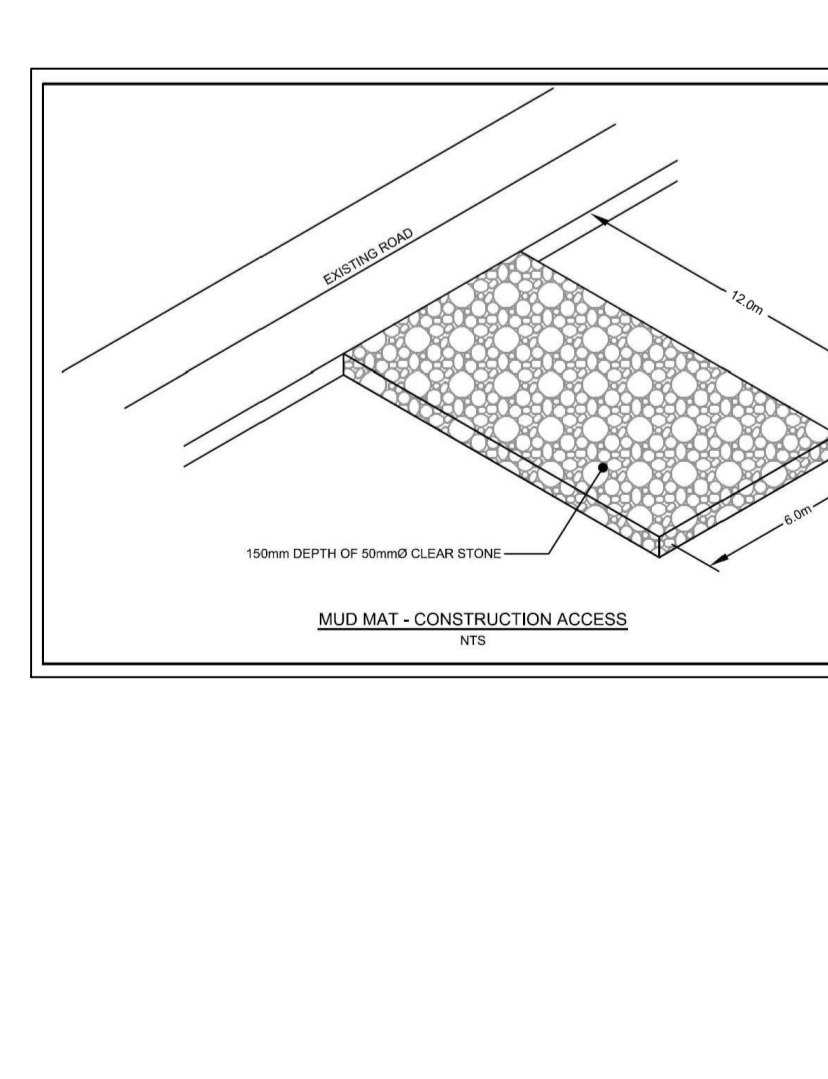
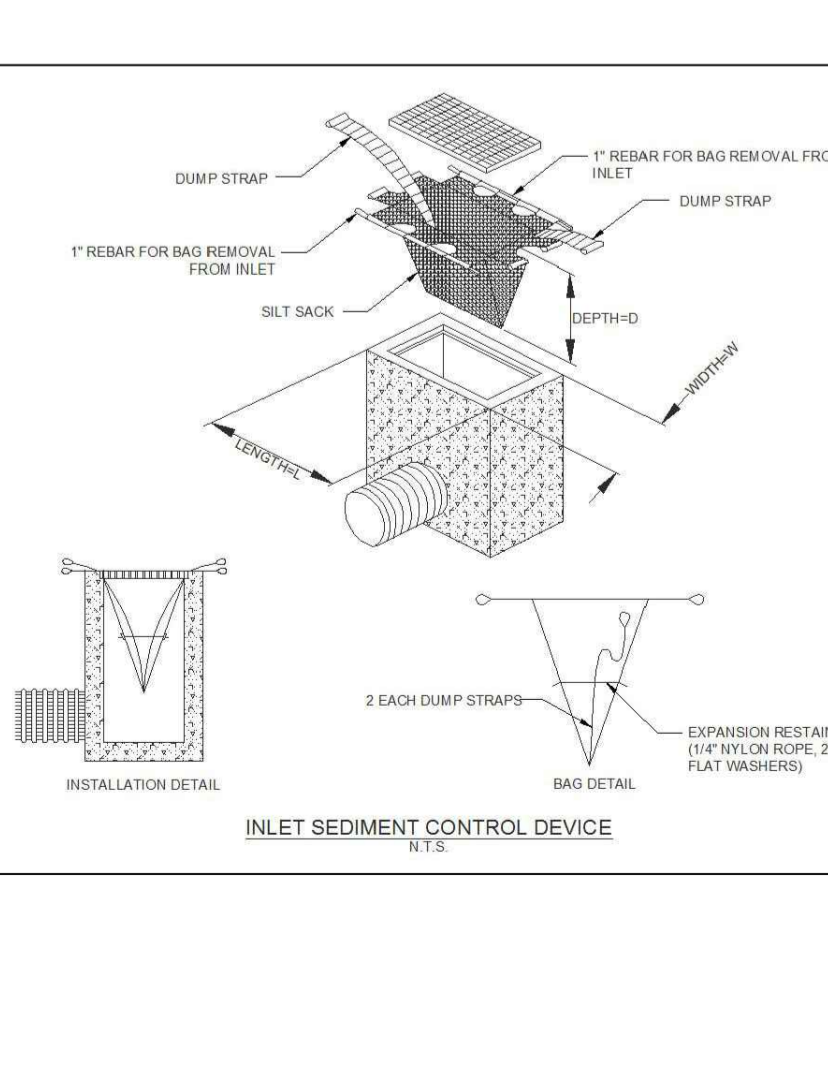
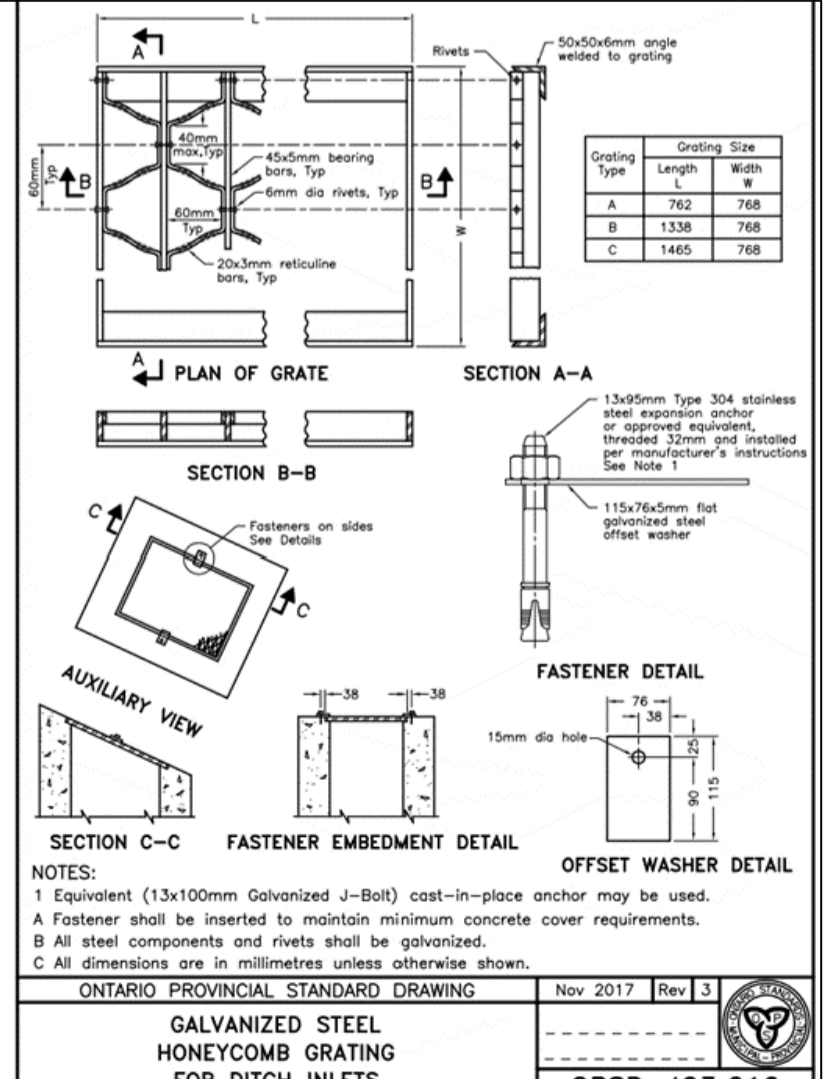
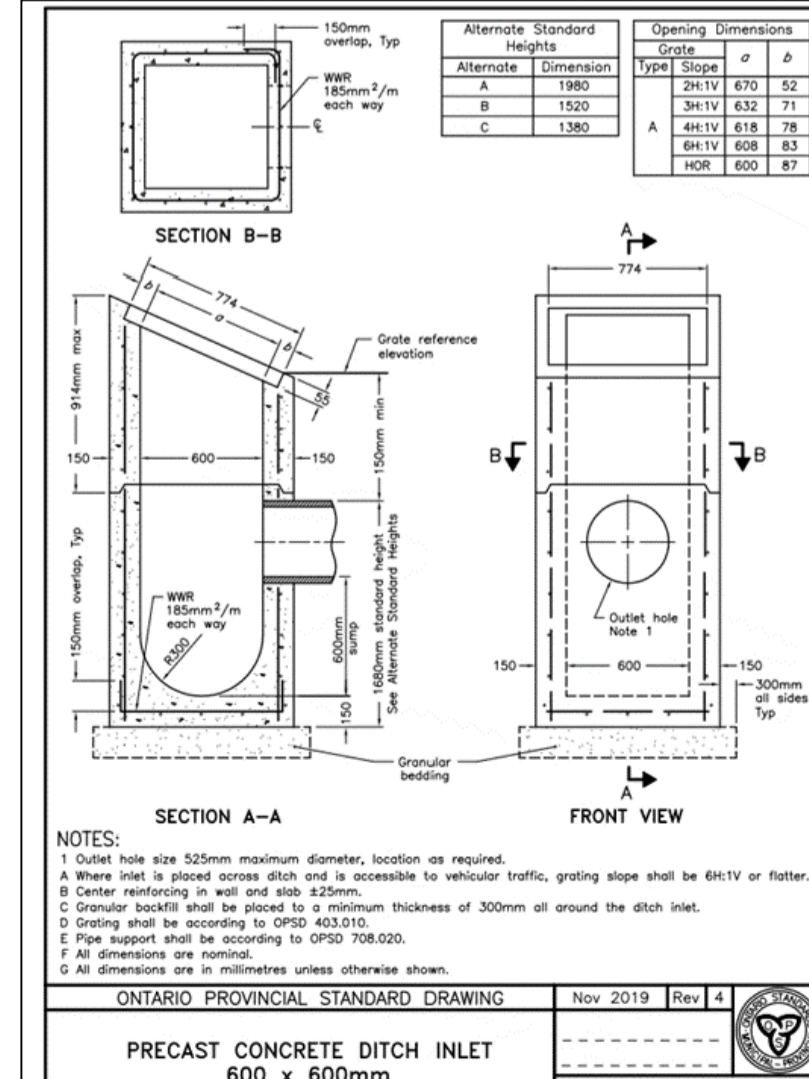
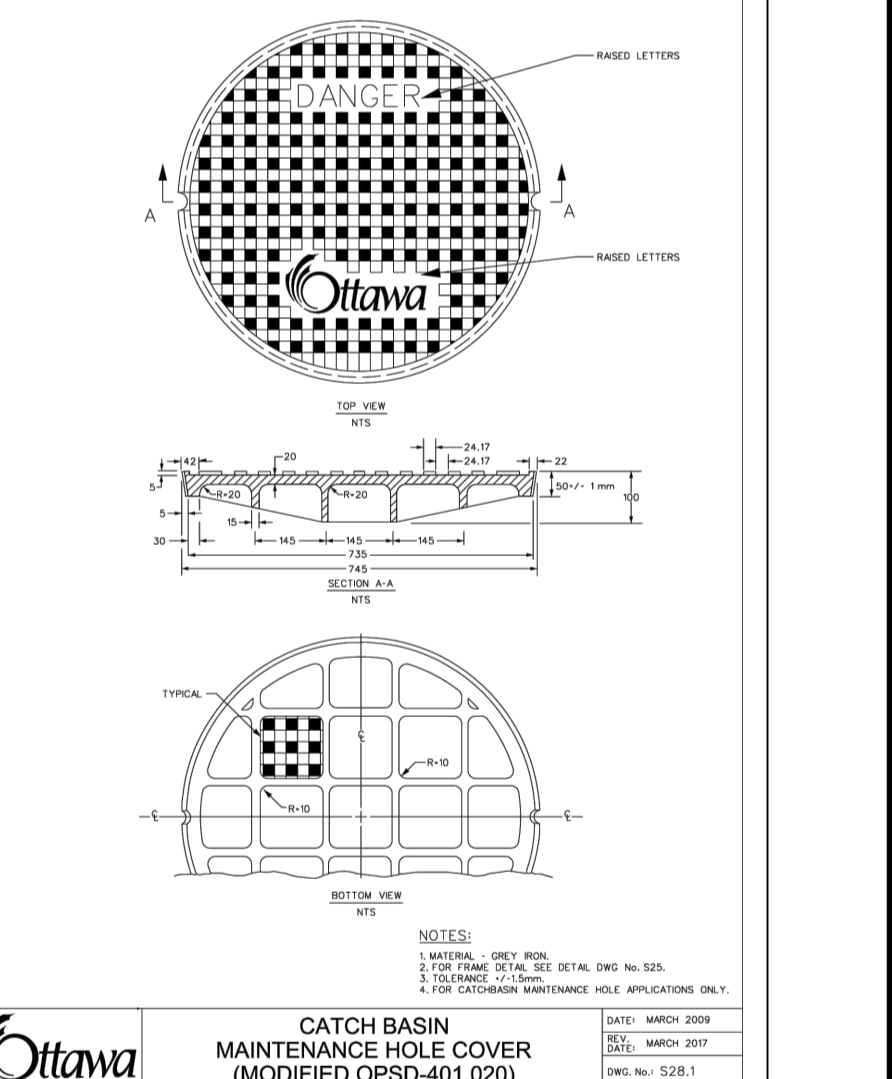
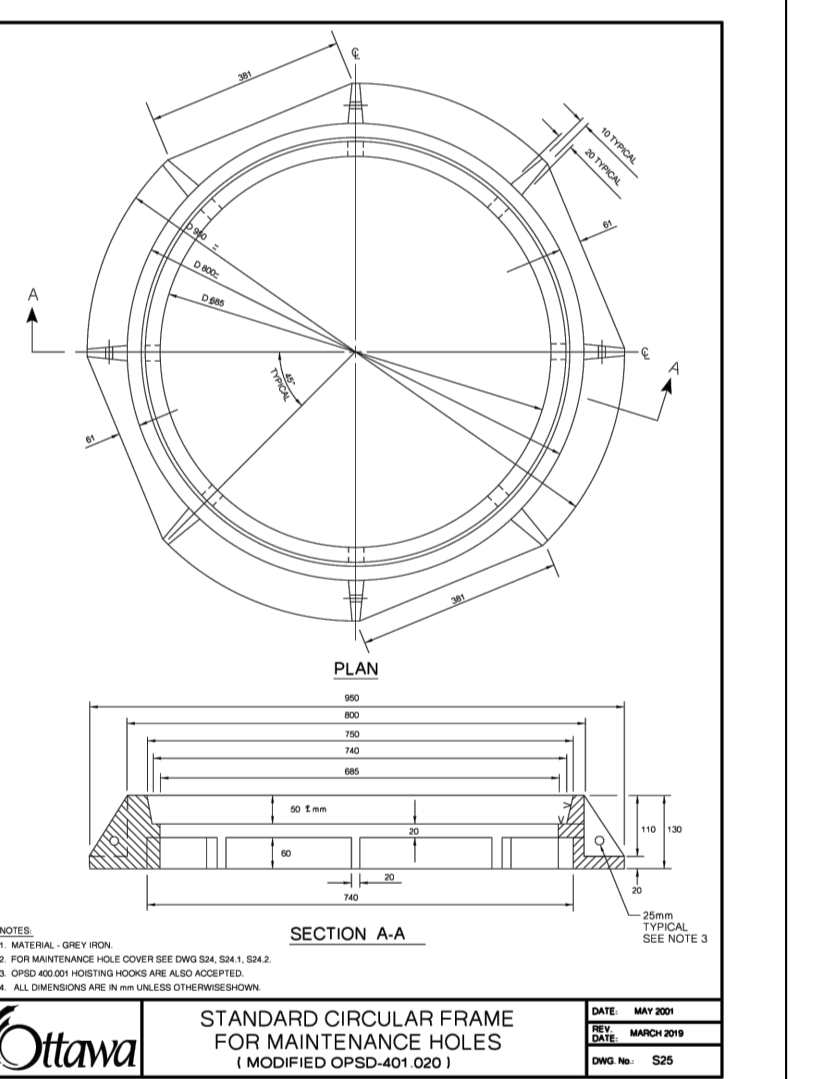
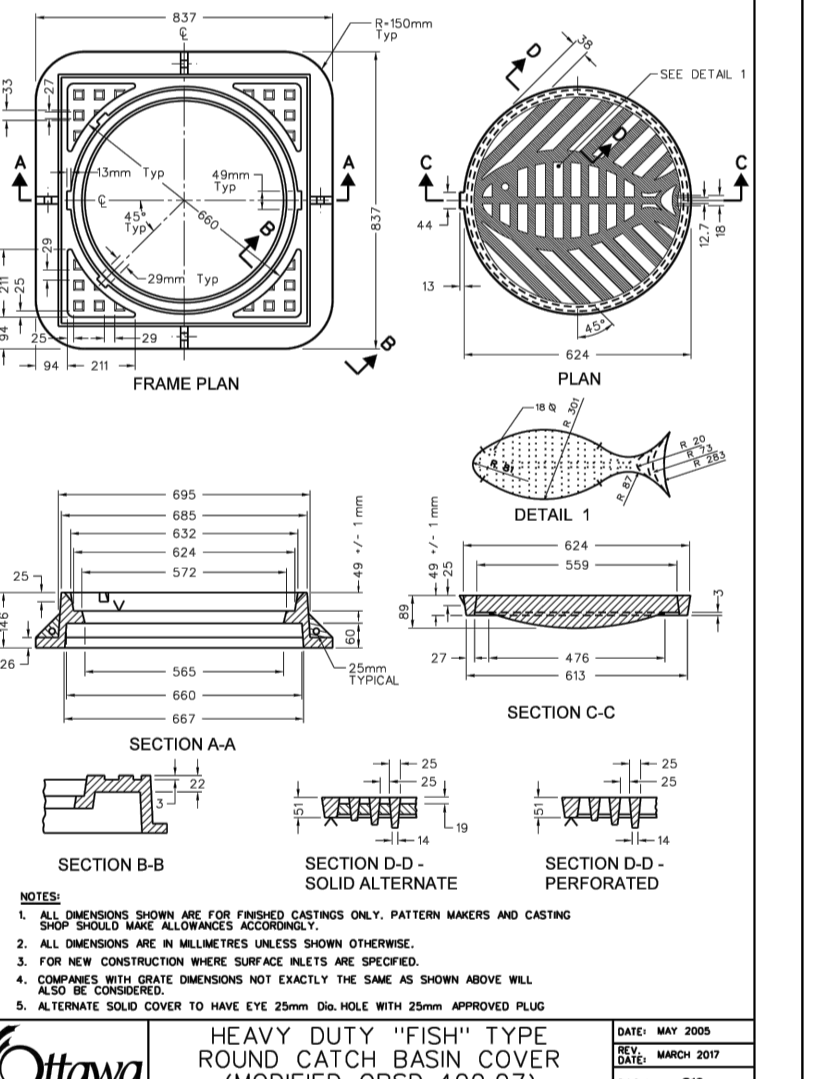
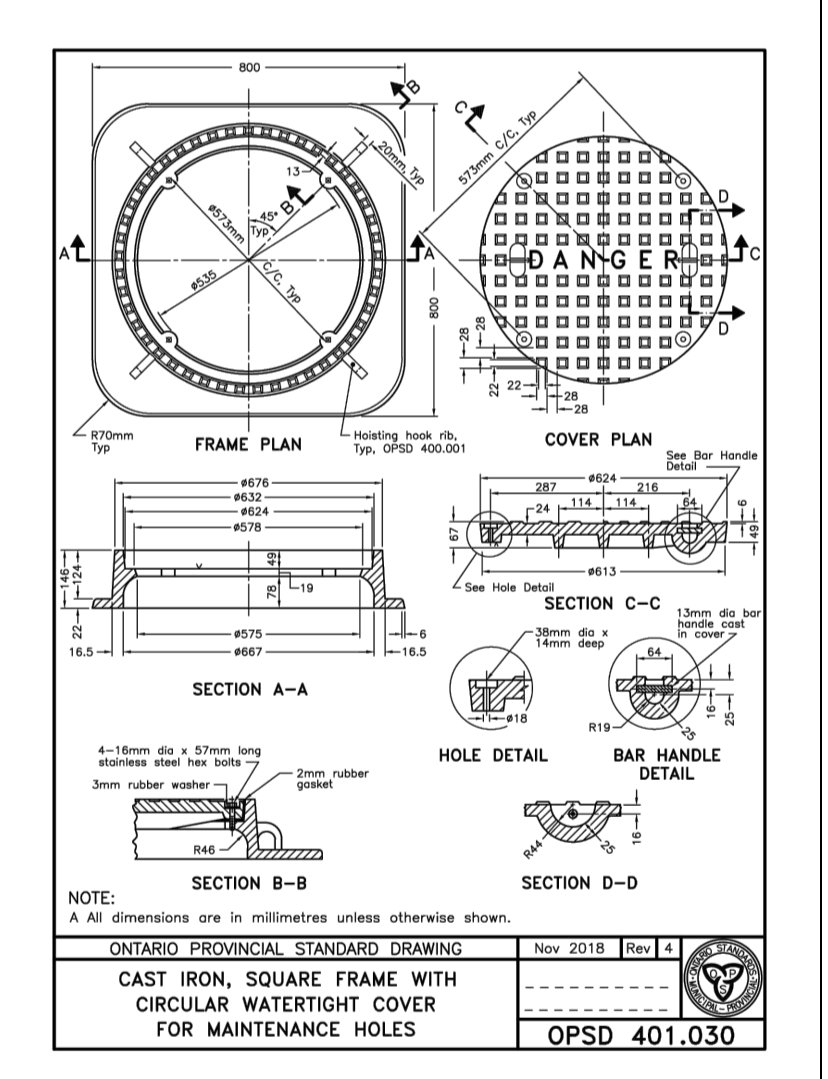
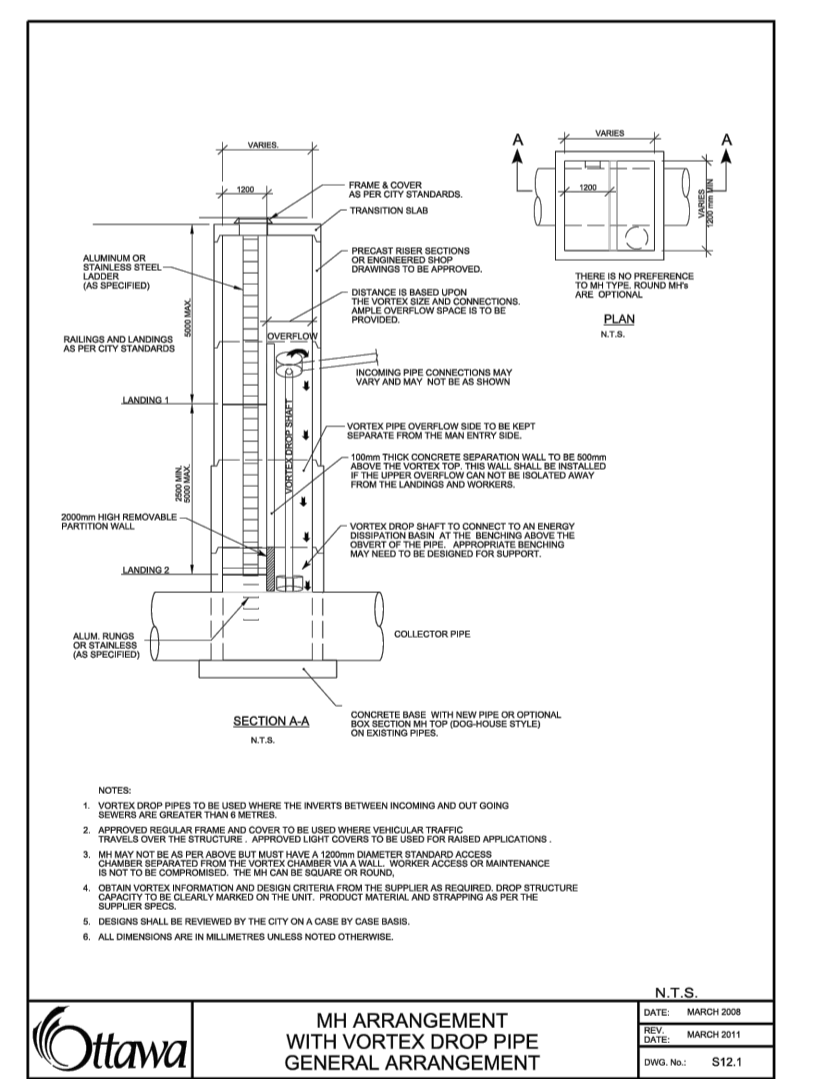
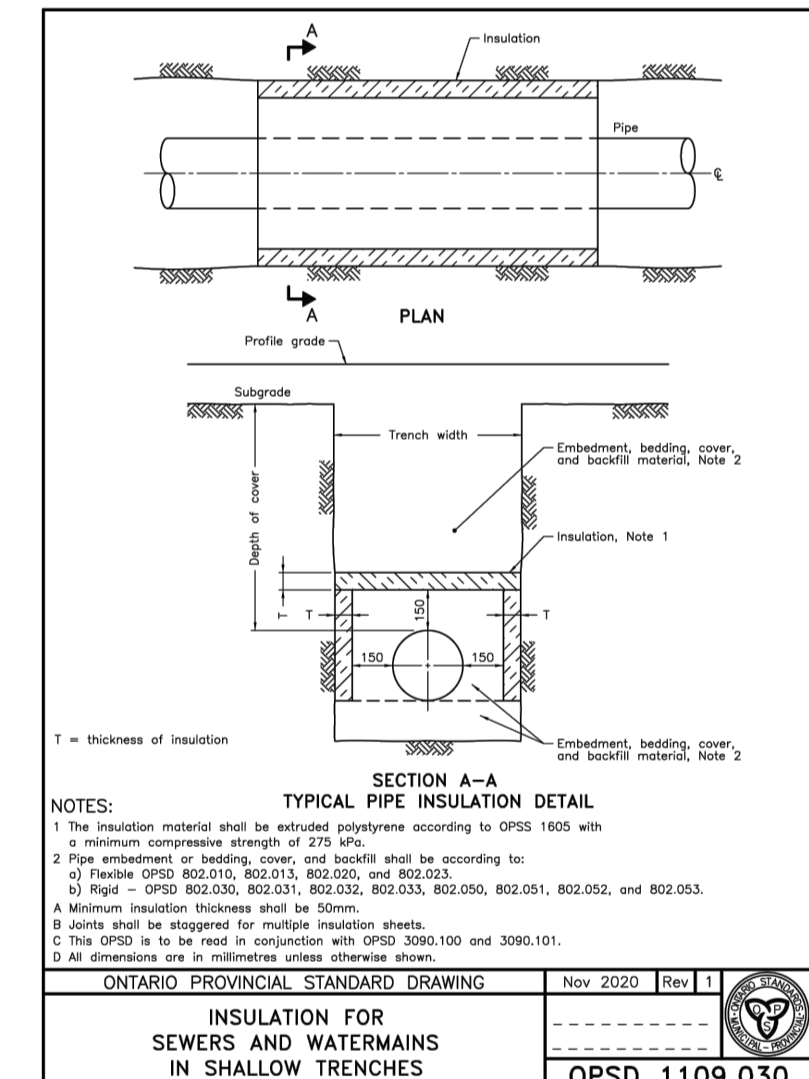

No.	REVISIONS	BY	DATE
10	ISSUED FOR APPROVAL	M.L.	14 JAN 2025
09	ISSUED FOR APPROVAL	M.L.	17 DEC 2024
08	ISSUED FOR APPROVAL	M.L.	24 OCT 2024
07	ISSUED FOR APPROVAL	M.L.	11 OCT 2024
06	ISSUED FOR APPROVAL	M.L.	08 AUG 2024
05	ISSUED FOR APPROVAL	S.V.	30 JUL 2024
04	ISSUED FOR APPROVAL	M.L.	28 JUN 2024
03	ISSUED FOR APPROVAL	M.L.	29 JAN 2024
02	ISSUED FOR APPROVAL	M.L.	25 OCT 2023
01	ISSUED FOR COORDINATION	M.L.	06 OCT 2023

**NOT AUTHENTIC UNLESS SIGNED AND DATED**

**LRL**  
 ENGINEERING | INGENIERIE  
 5430 Canotek Road | Ottawa, ON, K1J 9G2  
 www.lrl.ca | (613) 842-3434

**CLIENT**  
**TRIM WORKS DEVELOPMENT LTD**

**DESIGNED BY:** M.L. **DRAWN BY:** M.L. **APPROVED BY:** M.B.

**PROJECT**  
**PLAZA TRIM ROAD DEVELOPMENT**  
**1280 TRIM RD,**  
**OTTAWA, ON**

**DRAWING TITLE**  
**CONSTRUCTION DETAIL PLAN**

**PROJECT NO.** 230202  
**DATE** APRIL 2023

**C901**

**#19188**

D07-12-24-0089