



Stormwater Management Report and Servicing Brief

Plaza Trim Road Development
1280 Trim Rd.
Ottawa, Ontario

Prepared for:

Trim Works Developments Ltd.
110 Place d'Orleans Dr
Orleans, ON
K1C 2L9

Attention: Mr. Brent Harden

LRL File No.: 230202

Revised October 11, 2024
October 25, 2023



TABLE OF CONTENTS

1	INTRODUCTION AND SITE DESCRIPTION	1
2	EXISTING SITE AND DRAINAGE DESCRIPTION	1
3	SCOPE OF WORK	2
4	REGULATORY APPROVALS	2
5	STORMWATER MANAGEMENT	2
5.1	Existing Stormwater Infrastructure	2
5.2	Design Criteria	3
5.2.1	Water Quality	3
5.2.2	Water Quantity	3
5.3	Method of Analysis	3
5.4	Allowable Release Rate	3
5.5	Proposed Stormwater Quantity Controls	4
6	WATER SUPPLY AND FIRE PROTECTION	6
6.1	Existing Water Supply Services and Fire Hydrant Coverage	6
6.2	Water Supply Demand and Fire Flow	6
6.3	Water Supply Servicing Design	7
	TABLE 5: FIRE PROTECTION SUMMARY	8
7	SANITARY SERVICE	8
7.1	Existing Sanitary Sewer Services	8
7.2	Sanitary Sewer Servicing Design	8
8	EROSION AND SEDIMENT CONTROL	8
9	CONCLUSION	9
10	REPORT CONDITIONS AND LIMITATIONS	10



APPENDICES

- Appendix A Pre-consultation/Correspondence**
- Appendix B Stormwater Management Calculations**
- Appendix C Water Supply Calculations**
- Appendix D Sanitary Calculations**
- Appendix E Civil Engineering Drawings**
- Appendix F Survey/As-Built Drawings/Site Plan**



1 INTRODUCTION AND SITE DESCRIPTION

LRL Associates Ltd. was retained by Trim Works Development Ltd. to complete a Stormwater Management Analysis and Servicing Brief for a proposed one (1) storey commercial/industrial development located at 1280 Trim Rd in Ottawa, Ontario. The property is legally described as Lot 30, Concession 1, Geographic Township of Cumberland, City of Ottawa. Refer to Survey included in Appendix F. The location of the proposed development can be viewed in **Figure 1** below.



Figure 1: Aerial View of Proposed Development

The proposed commercial/industrial development will have a site area of approx. 5620 m² and will consist of 3 (three) buildings. Building #1 (325.2 sqm) is proposed for a restaurant, building #2 (557.5 sqm) is proposed for an offices and personal services, and building #3 (682.4 sqm) is proposed for an automotive service. The site will encompass a paved parking area in the middle and western/southern portion of the lot.

The proposed development will have 1 (one) vehicular entrance with a depressed curb and sidewalk along Trim Rd as well as two (2) pedestrian entrances from Trim Rd. For additional detail, refer to the architectural site plan included in **Appendix F**.

This report has been prepared in consideration of the terms and conditions noted above and with the civil drawings prepared for the proposed new development. Should there be any changes in the design features, which may relate to the stormwater management and servicing design considerations, LRL Associates Ltd. should be advised to review the report recommendations.

2 EXISTING SITE AND DRAINAGE DESCRIPTION

The portion of land to be developed has a rectangular shape with a frontage of approximately 62 m along Trim Rd and a depth of approximately 91 m. With these dimensions, the property has a surface area of approximately 0.56 ha. The property is surrounded with 1 (one) storey building to the west, two (2) storeys building to the south, grassed area in the west, and Trim Rd in the east. Currently, the proposed site consists of an aluminum sided building and a parking lot. The existing building and asphalt parking area will be demolished prior to the development. Stormwater from

the existing site flow uncontrolled towards the low-lying area in the northern/western portion of the site.

3 SCOPE OF WORK

As per applicable guidelines, the scope of work includes the following:

Stormwater management

- Calculate the allowable stormwater release rate.
- Calculate the anticipated post-development stormwater release rates.
- Demonstrate how the target quantity and quality control objectives will be achieved.

Water services

- Calculate the expected water supply demand at average and peak conditions.
- Calculate the required fire flow as per the Fire Underwriters Survey (FUS) method.
- Confirm the adequacy of water supply and pressure during peak flow and fire flow condition.
- Describe the proposed water distribution network and connection to the existing system.

Sanitary services

- Describe the existing sanitary sewers available to receive wastewater from the proposed development.
- Calculate peak flow rates from the proposed development.
- Describe the proposed sanitary sewer system.

4 REGULATORY APPROVALS

An MECP Environmental Compliance Approval is expected to be required for installation of the proposed storm and sanitary sewers within the site. A Permit to Take Water is not anticipated to be required for pumping requirements for sewer installation. The Rideau Valley Conservation Authority (RVCA) will need to be consulted to obtain municipal approval for site development. No other approval requirements from other regulatory agencies are anticipated.

5 STORMWATER MANAGEMENT

5.1 Existing Stormwater Infrastructure

The topography of the site in pre-development conditions was reviewed to determine the direction of flow from overland runoff. In pre-development conditions, majority of the stormwater from the catchment area EWS-01 appears to flow uncontrolled overland towards the Trim Rd right-of-way. Catchment areas EWS-02 and EWS-03 generally drains towards northwest and southwest, respectively. Refer to Pre-development Watershed Plan C701 in **Appendix E**.

As previously discussed, the east end of the subject property is bordered by Trim Rd. A dedicated 750 mm dia. storm sewer, flowing north, is available on the east side of the street for a potential



connection. In addition, there is an existing 375 mm dia. storm sewer on the west side of the property for a potential connection.

5.2 Design Criteria

The stormwater management criteria for this development are based on pre-consultation meeting with the City of Ottawa officials, the City of Ottawa Sewer Design Guidelines, 2012 (City Standards), as well as the Ministry of the Environment's Stormwater Management Planning and Design Manual, 2003 (SWMPD Manual).

5.2.1 Water Quality

To meet stormwater quality control objective, an enhanced level of protection with 80% TSS (Total Suspended Solid) removal is proposed for this site. A stormwater treatment unit, Jellyfish Filter model JF4-1 (or approved equivalent), is recommended which will be installed downstream of CBMH06.

5.2.2 Water Quantity

All storm events up to and including the 100-year event will be controlled to the 5-year pre-development level. The sites major overland flow route has been designed to ensure that storm events beyond the 100-year design storm can be safely conveyed overland towards Trim Rd. Right-of-Way (ROW). The minor systems (storm sewers) within the site are sized to convey the 5-year storm event flow from the site to the municipal storm sewer along the easement in the west.

Based on the pre-development catchment area calculations, the pre-development weighted runoff was calculated to be $C=0.39$. Detailed calculations can be found in **Appendix B**.

The post-development conditions are introducing an increase in impervious surfaces. Therefore, the quantity control measures will have to be implemented. The allowable release rate is calculated using the maximum runoff coefficient of $C=0.5$ or pre-development C value (whichever is smaller), as per the City of Ottawa requirements. The 100-year and 5-year post development flows will be controlled to the 5-year pre-development level.

5.3 Method of Analysis

The Modified Rational Method has been used to calculate the peak runoff rate from the site, and to quantify the detention storage required for quantity control. Refer to the design sheets (**Appendix B**) for allowable release rate as well as storage calculations.

5.4 Allowable Release Rate

The maximum allowable release rate was calculated for the 5-year pre-development condition. Based on pre-consultation meeting notes, runoff from post-development conditions must be controlled to the 5-year pre-development level using a maximum of $C=0.5$ for the runoff coefficient, for both minor and major storms, using a time of concentration not less than 10 minutes.



The Rational Method runoff coefficients (C) for each catchment have been calculated based on appropriately assigned coefficients weighted by area of land cover within the drainage area. A summary of catchment areas with calculated C values is included in **Appendix B**.

The 100-year and 5-year release rates from the subject site in pre-development condition are 108.18 L/s and 63.12 L/s, respectively. The release rates were calculated based on the entire watershed area of 0.562 ha, pre-development runoff coefficient of 0.39, and the time of concentration (T_c) 10 min. In post-development condition, the allowable release rate for this site will be **63.12 L/s**, which will be the maximum release rates to which the entire site will be controlled up the 100-year storm event.

5.5 Proposed Stormwater Quantity Controls

The proposed stormwater management quantity control for this development will be accomplished using an inlet control device (ICD) flow restrictor in the storm sewer. Ponding required as a result of quantity control will be accomplished through parking lot surface storage. The proposed site storm sewer and stormwater management system are shown on Site Servicing Plan C401 in **Appendix E** and detailed calculations can be found in **Appendix B**.

The existing site is delineated by catchments EWS-01, EWS-02 and EWS-03 (see Pre-development Watershed Plan C701 in **Appendix E**) which currently drains uncontrolled off the site. The site has been analyzed and post-development watersheds have been allocated, see Post-development Watershed Plan C702 in **Appendix E**. The proposed site grading will provide overland drainage to the proposed storm water management systems. Briefly,

- Runoff from catchment WS-01 (Bldg. 1 and entrance area) will be captured by CB01.
- Runoff from a small portion of parking lot, Bldg. 2 and Bldg.3 (delineated as WS-03) will be captured by CBMH03.
- Runoff from the north parking lot west of Bldg. 1 (delineated as WS-02) will be captured by CB02.
- Runoff from the drive through area (WS-04) will outlet to CBMH04.
- Runoff from the northwest parking lot will be captured by CBMH05 and CBMH06.
- A small portion of the exterior landscape boundary (watersheds WS-07 to WS-11) will drain off the property uncontrolled.

All overland stormwater captured using CB/CBMH will ultimately be conveyed, via underground storm sewers, to the City storm sewer running along the rear end of the property. **Table 1** summarizes the drainage areas and average runoff coefficient (C). Detailed calculations can be found in **Appendix B**.



Table 1: Post-Development Drainage Areas & Runoff Coefficient

Catchments	Area (ha)	Weighted Runoff Coefficient (C)	100-year Weighted Runoff Coefficient (25% increase)
WS-01 (controlled)	0.076	0.88	1.00
WS-02 (controlled)	0.033	0.79	1.00
WS-03 (controlled)	0.204	0.89	0.98
WS-04 (controlled)	0.038	0.66	0.82
WS-05 (controlled)	0.069	0.82	1.00
WS-06 (controlled)	0.090	0.81	1.00
WS-07 (uncontrolled)	0.020	0.77	0.96
WS-08 (uncontrolled)	0.006	0.53	0.67
WS-09 (uncontrolled)	0.009	0.59	0.74
WS-10 (uncontrolled)	0.007	0.35	0.44
WS-11 (uncontrolled)	0.008	0.51	0.64
Total	0.562	0.82	1.00

Tables 2 summarizes the release rates and storage volumes required to meet the allowable release rate.

Table 2: Summary of Stormwater Release Rate & Storage Volume (100-year)

Catchments	Area (Ha)	Release Rate (L/s)	Storage Required (m ³)	Storage Provided (m ³)
WS-01 to WS-06 (controlled)	0.511	43.79	155.81	157.25
WS-07 to WS-11 (uncontrolled)	0.051	19.33	N/A	N/A
Total	0.562	63.12	155.81	157.25

The project runoff exceeding the allowable release rate will be stored on-site via surficial ponding. The 100-year maximum ponding elevation and depths can be found on Stormwater Management Plan C601 in **Appendix E**.



To control the 100-year storm, the stormwater flow will be restricted at CBMH06 using an Inlet Control Device (ICD), Hydrovex Vortex Flow Regulator 150VHV-2 (or approved equivalent). This ICD will control stormwater runoff during the storm event greater than 5-year. Greater details of the selected ICD can be found in **Appendix B**.

The site is graded to have a maximum high-water level (HWL) of 59.25 m while providing required storage for the maximum controlled release rate of **43.79 L/s (H=2.73 m)**. Refer to drawing C601 in **Appendix E** for the proposed stormwater storage areas.

To accommodate the proposed site plan with a new entrance and sidewalk, a portion of the existing ditch along Trim Rd right-of-way needs to be filled. To do so, it is proposed to replace the existing DICB with a new CBMH and install a new DICB upstream keeping the existing ditch as-is (i.e. not filled) which is anticipated to provide some storage in case the downstream CB lead is surcharged during larger storm events. Refer to Grading Plan C301 and Servicing Plan C401 for additional details.

6 WATER SUPPLY AND FIRE PROTECTION

6.1 Existing Water Supply Services and Fire Hydrant Coverage

The subject property is located within the pressure zone 1E and is situated to the west of the existing 406 mm dia. PVC and 406 mm dia. DI watermain running along Trim Rd. Based on correspondence with the City, the later (406 mm dia. DI watermain) is currently feeding Zone 1E, thus chosen for connection to service the subject site. There are two (2) existing fire hydrants (FH) along Trim Rd Ave in proximity to the proposed site within 150m. Two additional FHs are available within 300 m. A schematic summarizing the locations of existing FHs can be seen in **Appendix C**.

6.2 Water Supply Demand and Fire Flow

According to the City of Ottawa Design Guidelines, the average water consumption rate for commercial and light industrial sites are 28000 and 35000 L/ha/d, respectively. Based on architectural site plan, the proposed site will have two commercial and one industrial buildings. The calculated water demands are summarized below, refer to **Appendix C** for calculation details.

- Average day demand = **0.20 L/s**
- Maximum daily demand = **0.30 L/s**
- Peak hour demand = **0.55 L/s**

The fire flow requirements were estimated using the method prescribed by Fire Underwriters Survey (FUS). This method is based on the area of the building to be protected, the type of construction, contents combustibility, presence of sprinkler and the separation distances with adjoining buildings. Based on these parameters, a minimum required fire flow demand of **150 L/s** was calculated, refer to **Appendix C** for the fire flow calculations.



6.3 Water Supply Servicing Design

The proposed building will be serviced by a new 100 mm dia. water service to be connected to the existing watermain on Trim Rd. Refer to servicing plan C401 for the layout of the proposed water services.

Table 3 below summarizes the design criteria which have been respected during the design of the water service connections at this development.

Table 3: Water Supply Design Criteria

Design Parameters	Value
Commercial water demand	28000 L/ha/d
Light Industrial demand	35000 L/ha/d
Minimum cover	2.4 m
Desired pressure range under maximum daily flow condition	50 and 80 psi
Minimum pressure under peak hourly flow condition	40 psi
Minimum pressure under the maximum day plus fire flow condition	20 psi

The boundary conditions provided by the City at the Trim Rd. proposed connection is summarized in **Table 4**.

Table 4: Boundary Conditions

Water Pressures at Trim Rd.			
HGL (m)		Pressure*	
		kPa	psi
Maximum HGL	114.1	510	74.0
Peak Hour	109.4	465	67.4
Max Day + Fire Flow	106.0	432	62.6
<i>*Assumed ground elevation at Connection 1 = 62.0 m</i>			

Comparing **Table 3** and **Table 4**, it is evident that the available water pressures at the proposed Trim Rd connection corroborates with the desired pressure range per City guidelines. As such, the maximum pressure is less than 80 psi, therefore a pressure reducing valve is not required.

For fire protection, there are four (4) existing fire hydrants in proximity to the proposed buildings that are available to provide the required fire flow demands of **9,000 L/min**. Refer to **Appendix C** for fire hydrant locations. **Table 5** below summarizes the aggregate fire flow of the contributing hydrants in proximity to the proposed development based on Table 18.5.4.3 of *ISTB-2018-02*.



Table 5: Fire Protection Summary

	Max. Fire Flow Demand (L/min)	Fire Hydrants(s) within 150m	Fire Hydrant(s) within 300m	Available Combined Fire Flow (L/min)
Contemplated Development	9000	2	2	(2 x 3785) + (2 x 2839) = 13248

The total available fire flow from contributing hydrants is equal to **13248 L/min** which is sufficient to provide adequate fire flow for the proposed development. A certified fire protection system specialist will need to be employed to design the building’s fire suppression system and confirm the actual fire flow demand.

7 SANITARY SERVICE

7.1 Existing Sanitary Sewer Services

Existing infrastructure surrounding the proposed development were reviewed. It was determined that there is an existing 250 mm dia. sanitary sewer, running south to north, along the rear end of the property. Additionally, there is a 450 mm dia. CONC sanitary sewer, running south to north, along Trim Rd.

7.2 Sanitary Sewer Servicing Design

The parameters used to calculate the anticipated sanitary flows are:

- Commercial average demand of 28000 L/ha/day
- Light industrial demand of 35000 L/ha/day
- A commercial peaking factor of 1.5
- Industrial peak factor of 7.75 as determined from Appendix 4-B (SDG 2012)
- An infiltration rate of 0.33 L/s/ha

Based on these parameters and the total site area of 0.562 ha, the total anticipated sanitary flow was estimated to **1.11 L/s**. Refer to **Appendix D** for the site sanitary sewer design sheet.

The proposed new buildings will be serviced with a new 150 mm dia. sanitary service which will be connected to the existing 250 mm dia. sanitary sewer located along west end of the property. The proposed 150mm dia. PVC sanitary service will be installed at a slope of 2 - 6% to ensure that majority of calculated actual flow velocity \geq self-cleansing velocity of 0.6 m/s during peak flow condition. Refer to sanitary design sheet in **Appendix D** and Servicing Plan C401 in **Appendix E** for the proposed sanitary servicing.

8 EROSION AND SEDIMENT CONTROL

During construction, erosion and sediment controls will be provided primarily via a sediment control fence to be erected along the perimeter of the site where runoff has the potential of leaving the site. Inlet sediment control devices are also to be provided in any catch basin and/or manholes



in and around the site that may be impacted by the site construction. Construction and maintenance requirements for erosion and sediment controls are to comply with Ontario Provincial Standard Specification OPSS.MUNI 805. Refer to Erosion and Sediment Control Plan C101 in **Appendix E** for additional details.

9 CONCLUSION

This Stormwater Management Report and Servicing Brief for the proposed development at 1280 Trim Rd presents the rationale and details for the servicing requirements for the subject property. In accordance with the report objectives, the servicing requirements for the development are summarized below:

Stormwater Management

- The storm water release rates from the proposed development will meet the pre-development allowable release rate of 63.12 L/s.
- Stormwater quantity control objectives will be met with flow restriction using an inlet control device and on-site stormwater storage in the parking lot.
- Stormwater quality control requirements of 80% TSS removal will be met by an on-site stormwater treatment unit, Jellyfish Filter (or approved equivalent).

Water Service

- The estimated maximum hour demand of the proposed development, based on anticipated use is 0.55 L/s.
- The maximum required fire flow was calculated at 150 L/s, using the FUS method.
- For fire protection, there are four (4) existing fire hydrants along Trim Rd in proximity to the proposed buildings within 300m.
- The proposed building will be serviced by a new 100 mm dia. water service to be connected to the existing 406 mm dia. watermain on Trim Rd.

Sanitary Service

- The anticipated sanitary peak flow from the proposed development is 1.11 L/s.
- The proposed buildings will be serviced by a new 150 mm dia. sanitary service to be connected to the existing sanitary sewer located near the northwest corner of the property.



10 REPORT CONDITIONS AND LIMITATIONS

The report conclusions are applicable only to this specific project described in the preceding pages. Any changes, modifications or additions will require a subsequent review by LRL Associates Ltd. to ensure the compatibility with the recommendations contained in this document. If you have any questions or comments, please contact the undersigned.

Prepared by:
LRL Associates Ltd.

Maxime Longtin

Maxime Longtin
Civil Engineering Technologist



Mohan Basnet, P.Eng.
Civil Engineer



APPENDIX A
Pre-consultation/Correspondance

1280 Trim Road (Ward 1) – Pre-application Consultation Notes

Meeting Date: Thursday, March 23, 2023

Notes sent: Tuesday, June 13, 2023

Attendees	Christine McCuaig, Applicant Dayna Edwards, Applicant Brent Harden, Liisa Mannila Rani Nahas, JLR Richards James Salem Kelsey Charie, Project Manager (Development Review), City of Ottawa Lucy Ramirez, Planner (Development Review), City of Ottawa Josiane Gervais, Project Manager (Transportation), City of Ottawa Jessica Button, Planner (Parks), City of Ottawa Molly Smith, Planner (Urban Design), City of Ottawa
Regrets	Hayley Murray, Forester – PRED, City of Ottawa

Contents

1280 Trim Road (Ward 1) – Pre-application Consultation Notes.....	1
Proposal Summary	2
City Surveyor	5
Engineering	5
Forestry	10
Tree Conservation Report (TCR) requirements	11
Landscape Plan (LP) tree planting requirements	11
Planning.....	13
Official Plan.....	13
Secondary Plan.....	14

Zoning By-law Amendment	15
Guidelines	16
Questions and Comments:.....	16
Planning Application Fees.....	17
Submission Requirements	19
High Performance Development Standards.....	19
Urban Design.....	20
Transportation	21
Parks	23
Waste Reduction Workplan Summary	23
Next Steps.....	23
Bill 109.....	23
Attachments.....	24

Proposal Summary

Large rectangular site that is approximately 5,619.5 square metres (0.56 ha), the property has a lot depth of approximately 91 metres, and 62 metres of frontage along Trim Road, an arterial road. On site there is an industrial 2-storey building, a large gravel parking area, and an unkempt green area. The northern side lot line abuts two lots: 1270 Trim Road and 510 Lacolle Way. There is a Tim Hortons Drive through restaurant and a gas station at 1270 Trim Road and a daycare centre, La petite échelle, at 510 Lacolle Way, which is zoned Light Industrial [urban exception 1567] 21 metre height limit (IL[1567] H(21)). The daycare’s amenity space is located adjacent to the unkempt green area on the subject property. The southern side lot line abuts 1290 Trim Road, which contains a recreational and athletic facility (A foot above fitness), and a daycare and play centre (Kids Kingdom). The rear lot line abuts the rear yard of a church at 3775 St – Joseph Boulevard (Église Baptiste Évangélique du Bon Berger), which is zoned Minor Institutional subzone B (I1B).

The site will be redeveloped with three new buildings containing the following uses:

- Building 1: Five offices and personal services uses;
- Building 2: Two restaurant uses including a drive-through;
- Building 3: automobile service use.



Figure 1: Capture from geoOttawa, identifying the subject property.

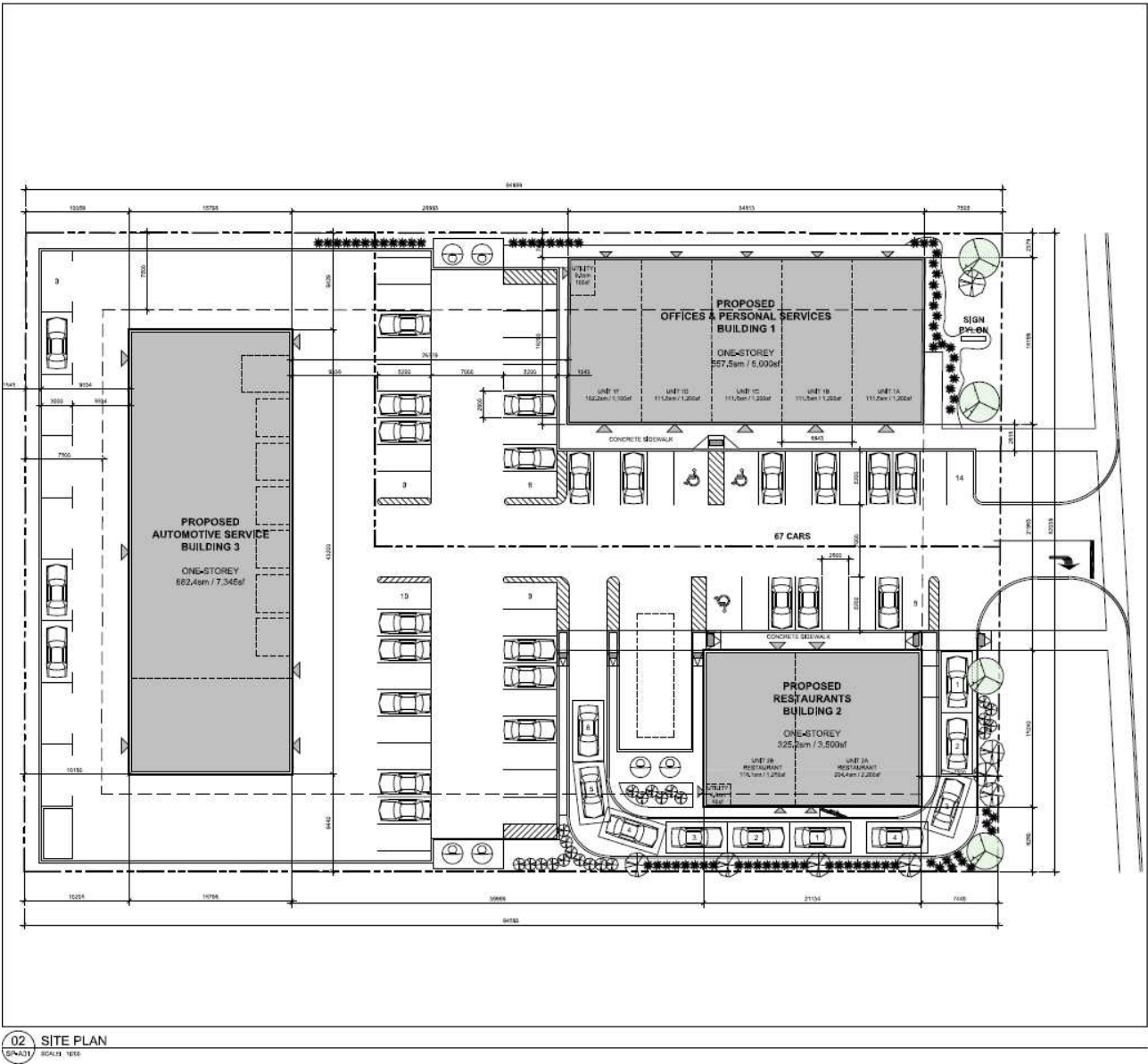

02 SITE PLAN
SCALE: 1:500

Figure 2: Concept Plan

City Surveyor

Bill Harper | City's Surveyor | Bill.Harper@ottawa.ca

The determination of property boundaries, minimum setbacks and other regulatory constraints are a critical component of development. An Ontario Land Surveyor (O.L.S.) needs to be consulted at the outset of a project to ensure properties are properly defined and can be used as the geospatial framework for the development.

Topographic details may also be required for a project and should be either carried out by the O.L.S. that has provided the Legal Survey or done in consultation with the O.L.S. to ensure that the project is integrated to the appropriate control network.

Engineering

Kelsey Charie, Project Manager Infrastructure Approvals | Kelsey.Charie@ottawa.ca

List of Reports and Plans (If applicant elects to pursue Rezoning in advance of SPC):

1. Assessment of Adequacy of Public Services Report
2. Geotechnical Report

List of Reports and Plans (Concurrent Site Plan Control and Rezoning applications):

3. Site Servicing Plan
4. Grading and Ponding Plan
5. Erosion and Sediment Control Plan
6. Pre-development Storm Drainage Plan
7. Post-Development Storm Drainage Plan
8. Stormwater Management and Site Servicing Report
9. Geotechnical Report

Please note the following information regarding the engineering design submissions for the above noted site:

1. The Servicing Study Guidelines for Development Applications are available at the following address:
<https://ottawa.ca/en/city-hall/planning-and-development/how-develop-property/developmentapplication-review-process-2/guide-preparing-studies-and-plans>

2. Servicing and site works shall be in accordance with the following documents:
 - i. Ottawa Sewer Design Guidelines, Second Edition, (October 2012), including Technical Bulletins, ISDTB-2014-01, PIEDTB-2016-01, ISTB 2018-01, ISTB-2018-04, and ISTB-2019-02
 - ii. Ottawa Design Guidelines – Water Distribution, First Edition, (July 2010), including Technical Bulletins ISD-2010-2, ISDTB-2014-02, ISTB-2018-02, and ISTB-2021-03
 - iii. Geotechnical Investigation and Reporting Guidelines for Development Applications in the
 - iv. City of Ottawa (Revised 2008)
 - v. City of Ottawa Slope Stability Guidelines for Development Applications (Revised 2012)
 - vi. City of Ottawa Environmental Noise Control Guidelines (January, 2016)
 - vii. City of Ottawa Hydrogeological and Terrain Analysis Guidelines (March 2021)
 - viii. City of Ottawa Park and Pathway Development Manual (2012)
 - ix. City of Ottawa Accessibility Design Standards (2012)
 - x. Ottawa Standard Tender Documents (latest version)
 - xi. Ontario Provincial Standards for Roads & Public Works (2013)
3. Record drawings and utility plans are also available for purchase from the City (Contact the City's Information Centre by email at InformationCentre@ottawa.ca or by phone at (613) 580-2424 x 44455
4. The Stormwater Management Criteria for the subject site is to be based on the following:
 - i. The pre-development condition of the site including the pre-development runoff coefficient or a maximum equivalent value of 0.5, whichever is less (§ 8.3.7.3).
 - ii. Flows to the storm sewer in excess of the 5-year pre-development storm release rate, up to and including the 100-year storm event, must be detained on site.

- iii. The 5-yr storm event using the IDF information derived from the Meteorological Services of Canada rainfall data, taken from the MacDonald Cartier Airport, collected 1966 to 1997.
- iv. A calculated time of concentration (Cannot be less than 10 minutes).
- v. Ensure no overland flow for all storms up to and including the 100-year event. Provide adequate emergency overflow conveyance off-site
- vi. Quality control requirements to be provided by Rideau Valley Conservation Authority (RVCA).

5. Services:

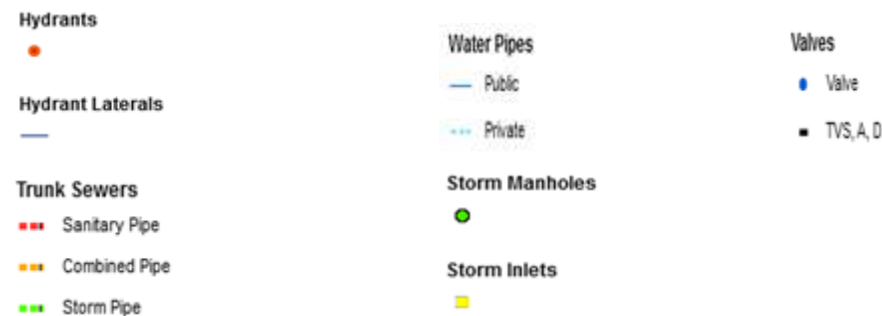

Figure 3: Capture from [geoOttawa](#) with approximate services

- i. A plan view of the approximate services may be seen above.
 - a. Available infrastructure for future service connections:
 - (i) 406 mm dia. water main located within Trim Road.
 - (ii) 250 mm dia. sanitary sewer located in the sewer easement at the West of the site
 - (iii) 375 mm dia. storm sewer located in the sewer easement at the West of the site
 - ii. Provide existing servicing information and the recommended location for the proposed connections. Services should ideally be grouped in a common trench to minimize the number of road cuts.
 - iii. Provide information on the monitoring manhole requirements – should be located in an accessible location on private property near the property line (ie. Not in a parking area).
 - iv. Provide information on the type of connection permitted
Sewer connections to be made above the springline of the sewermain as per:
 - a. Std Dwg S11.1 for flexible main sewers – connections made using approved tee or wye fittings.
 - b. Std Dwg S11 (For rigid main sewers) – lateral must be less than 50% the diameter of the sewermain,
 - c. Std Dwg S11.2 (for rigid main sewers using bell end insert method) – for larger diameter laterals where manufactured inserts are not available; lateral must be less than 50% the diameter of the sewermain,
 - d. Connections to manholes permitted when the connection is to rigid main sewers where the lateral exceeds 50% the diameter of the sewermain. – Connect obvert to obvert with the outlet pipe unless pipes are a similar size.
 - e. No submerged outlet connections.
 - v. *Please provide estimated sanitary flows with the first submission, to allow the City to confirm whether there are any downstream capacity constraints.*

6. Civil consultant must request boundary conditions from the City's assigned Project Manager prior to first submission. Water Boundary condition requests must include the location of the service and the expected loads required by the proposed development. Please provide the following information:
 - i. Location of service(s)
 - ii. Type of development and the amount of fire flow required (as per FUS, 2020).
 - iii. Average daily demand: ___ l/s.
 - iv. Maximum daily demand: ___ l/s.
 - v. Maximum hourly daily demand: ___ l/s.
 - vi. Hydrant location and spacing to meet City's Water Design guidelines.
 - vii. Water supply redundancy will be required for more than 50 m³/day water demand.
7. Phase 1 ESAs and Phase 2 ESAs must conform to clause 4.8.4 of the Official Plan that requires that development applications conform to Ontario Regulation 153/04.
8. All development applications should be considered for an Environmental Compliance Approval (ECA) by the Ministry of the Environment, Conservation, and Parks (MECP);
 - i. The consultants determine if an approval for sewage works under Section 53 of OWRA is required and determines what type of application. The City's project manager may help confirm and coordinate with the MECP as required.
 - ii. The project will be either transfer of review (standard), transfer of review (additional), direct submission, or exempt as per O. Reg. 525/98.
 - iii. Pre-consultation is not required if applying for standard or additional works (Schedule A of the Agreement) under Transfer Review.
 - iv. Pre-consultation with local District office of MECP is recommended for direct submission.
 - v. Consultant completes an MECP request form for a pre-consultation. Send request to moeccottawasewage@ontario.ca

- vi. ECA applications are required to be submitted online through the MECP portal. A business account required to submit ECA application. For more information visit <https://www.ontario.ca/page/environmental-compliance-approval>

NOTE: Site Plan Approval, or Draft Approval, is required before an application is sent to the MECP.

9. General Engineering Submission requirements:

- i. As per section 53 of the Professional Engineers Act, O. Reg 941/40, R.S.O. 1990, all documents prepared by engineers must be signed and dated on the seal.
- ii. All required plans are to be submitted on standard A1 size sheets (594mm x 841mm) sheets, utilizing a reasonable and appropriate metric scale as per City of Ottawa Servicing and Grading Plan Requirements: title blocks are to be placed on the right of the sheets and not along the bottom. Engineering plans may be combined, but the Site Plans must be provided separately. Plans shall include the survey monument used to confirm datum. Information shall be provided to enable a non-surveyor to locate the survey monument presented by the consultant.
- iii. All required plans & reports are to be provided in *.pdf format (at application submission and for any, and all, re-submissions)

Should you have any questions or require additional information, please contact kelsey.charie@ottawa.ca

Forestry

Hayley Murray| Planning Forester | hayley.murray@ottawa.ca

1. The conifers that line the northern property, if in good condition, could be candidates for retention. Their spread is roughly six metres from the property boundary. An interior yard setback that would allow for retention of these trees would have to be six metres or greater
 - a. If not feasible, then a setback that could accommodate tree planting should be provided– ideally 4.5m from a buildings edge to where the tree would be planted. The more space the better to increase the likelihood of tree establishment and health.

2. There are hydros line along Trim Road, this will limit was size of trees that can be planted here. It's possible to plant a medium sized canopy tree six metres from the hydro line, any less would be a small canopy tree providing minimal benefit to the urban canopy.

Tree Conservation Report (TCR) requirements

1. The Tree Conservation Report (TCR) must list all trees on site, as well as off-site trees if the Critical Root Zone (CRZ) extends into the developed area, by species, diameter and health condition
 - i. please identify trees by ownership – private onsite, private on adjoining site, city owned, boundary (trees on a property line)
2. If trees are to be removed, the TCR must clearly show where they are, and document the reason they cannot be retained
3. All retained trees must be shown, and all retained trees within the area impacted by the development process must be protected as per City guidelines available at [Tree Protection Specification](#) or by searching Ottawa.ca
4. The location of tree protection fencing must be shown on the plan
5. The City encourages the retention of healthy trees; if possible, please seek opportunities for retention of trees that will contribute to the design/function of the site.
6. For more information on the process or help with tree retention options, contact Hayley Murray hayley.murray@ottawa.ca or on [City of Ottawa](#)

Landscape Plan (LP) tree planting requirements

Minimum Setbacks

1. Maintain 1.5m from sidewalk or MUP/cycle track or water service laterals.
2. Maintain 2.5m from curb
3. Coniferous species require a minimum 4.5m setback from curb, sidewalk or MUP/cycle track/pathway.
4. Maintain 7.5m between large growing trees, and 4m between small growing trees. Park or open space planting should consider 10m spacing, except where otherwise approved in naturalization / afforestation areas. Adhere to Ottawa

Hydro's planting guidelines (species and setbacks) when **planting around overhead primary conductors.**

Tree specifications

1. Minimum stock size: 50mm tree caliper for deciduous, 200cm height for coniferous.
2. Maximize the use of large deciduous species wherever possible to maximize future canopy coverage
3. Tree planting on city property shall be in accordance with the City of Ottawa's Tree Planting Specification; and include watering and warranty as described in the specification (can be provided by Forestry Services).
4. Plant native trees whenever possible
5. No root barriers, dead-man anchor systems, or planters are permitted.
6. No tree stakes unless necessary (and only 1 on the prevailing winds side of the tree)

Hard surface planting

1. Curb style planter is highly recommended
2. No grates are to be used and if guards are required, City of Ottawa standard (which can be provided) shall be used.
3. Trees are to be planted at grade

Soil Volume

1. Please document on the LP that adequate soil volumes can be met:

Tree Type/Size	Single Tree Soil Volume (m3)	Multiple Tree Soil Volume (m3/tree)
Ornamental	15	9
Columnar	15	9
Small	20	12
Medium	25	15
Large	30	18
Conifer	25	15

2. Please follow the City's 2017 Tree Planting in Sensitive Marine Clay guidelines

Tree Canopy

1. The landscape plan shall show how the proposed tree planting will replace and increase canopy cover on the site over time, to support the City’s 40% urban forest canopy cover target.
2. At a site level, efforts shall be made to provide as much canopy cover as possible, through tree planting and tree retention, with an aim of 40% canopy cover at 40 years, as appropriate. Indicate on the plan the projected future canopy cover at 40 years for the site.

For additional information on the following please contact hayley.murray@ottawa.ca

Planning

Lucy Ramirez | Planner – Development Review | lucy.ramirez@ottawa.ca

Official Plan

Per the New Official Plan (2022) the subject property is designated Suburban Corridor - Minor, (Schedule A and B8), and abuts land designated Mixed Industrial.

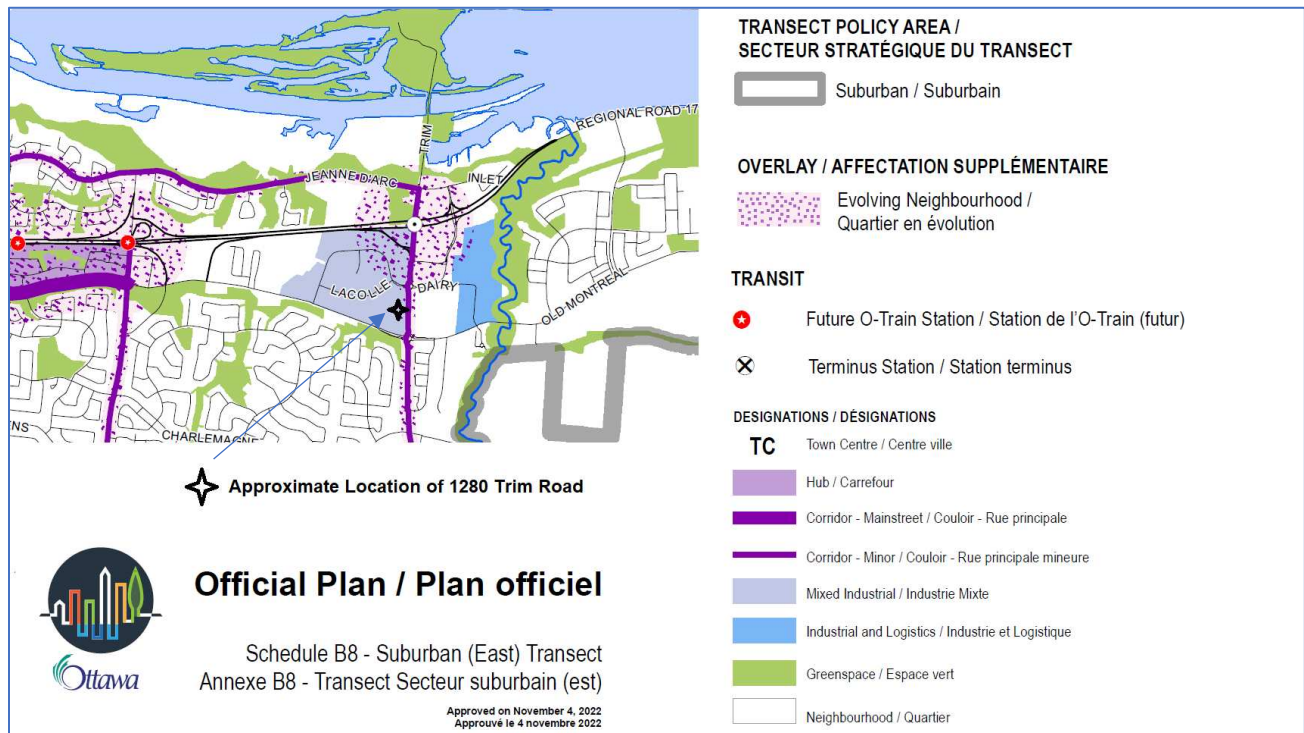

Figure 4: Capture of Schedule B8 with the approximate location of 1280 Trim Road shown.

Per the Official Plan development along corridors shall generally be located to frame adjacent street and should provide an appropriate setback within the street context, with clearly visible main entrances from public sidewalks (policy 4.6.5.2).

The proposal should include buildings with active frontages, which the OP defines as follows:

Active Frontages

Building frontages that animate the public spaces they face through:

- (a) *pedestrian-oriented retail, commercial or institutional uses, or residential uses whose main front door is on said frontage;*
- (b) *doors that can be used by the general public directly from the sidewalk or public space to gain access to the building and use at all hours of regular operation, or to visit the residents of the dwelling;*
- (c) *architectural features and details that enhance pedestrian safety and provide visual interest to enrich pedestrian experience; and*
- (d) *the provision of a separate municipal address for each active entrance, where appropriate.*

Secondary Plan

Within the Orléans Corridor Secondary Plan (council approved in Sept 2022 under appeal), the subject property is designated *Trim Minor Corridor* and six storey mid-rise buildings are envisaged. In the nearby *Station Core and Station Periphery* areas high rise buildings are envisaged. Along corridors, active frontages are required to enhance the public realm and animate the street (section 4.5).

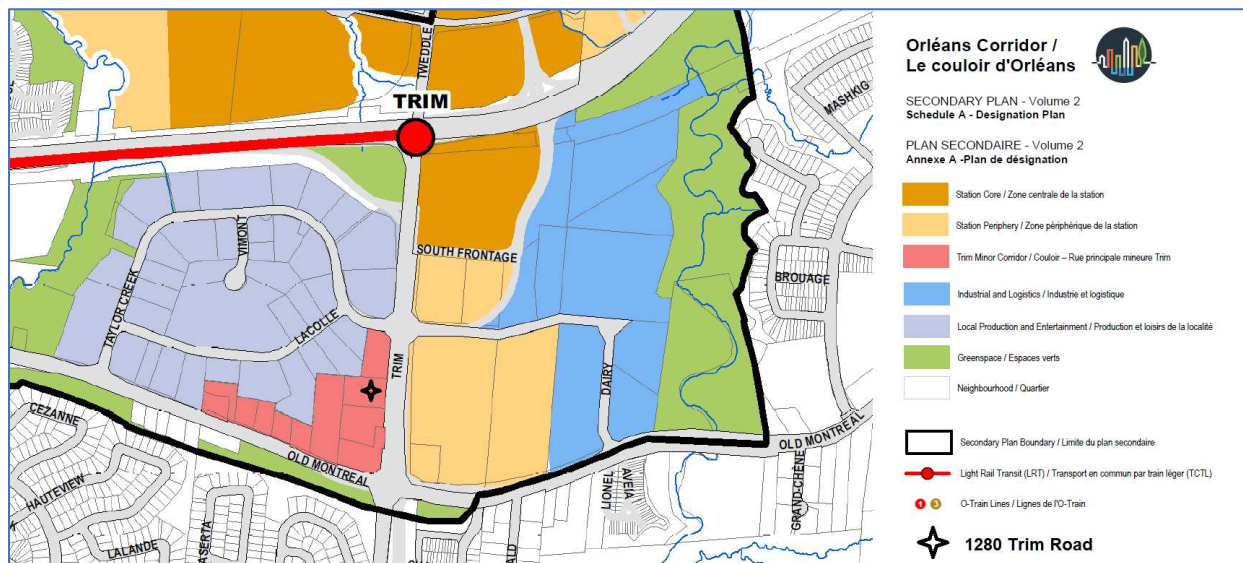

Figure 5: Capture of Orléans Corridor Schedule A – Designation Plan with the location of 1280 Trim Road shown.

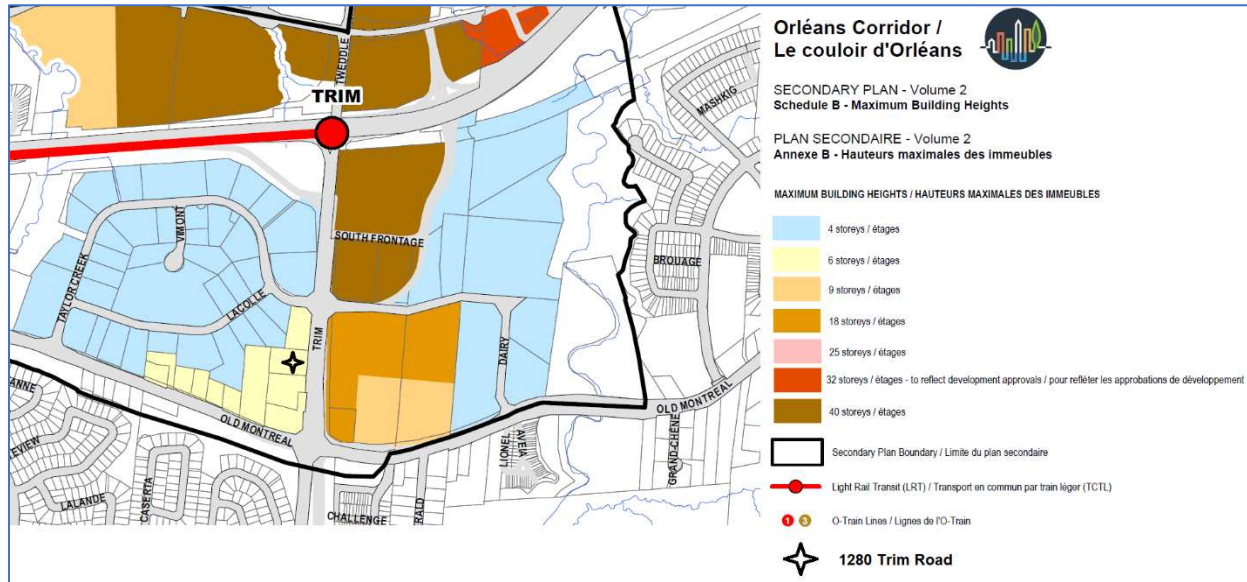

Figure 6: Capture of Orléans Corridor Schedule B – Maximum Building Heights with the location of 1280 Trim Road Shown.

Trim Minor Corridor

See policy extract below from section 5.6 of the secondary plan:

5.6 Trim Minor Corridor

The Trim Minor Corridor is intended to support the adjacent Local Production and Entertainment designation and the Trim O-train Station.

- (1) In addition to the uses permitted in the Local Production and Entertainment designation, commercial, restaurant and hotel uses may be permitted.*
- (2) Residential is not permitted.*
- (3) New or enhanced cycling and pedestrian connections will be pursued through tools such as: Site Plan Control, Community Benefits Agreements and traffic calming, in association with proposals for new development.*
- (4) Development of sensitive uses such as a hotel is conditional on the submission of a Noise and Vibration study, and an analysis of existing or potential land use conflicts demonstrating compatibility.*
- (5) Design strategies shall be implemented which may include locating non-residential sensitive land uses in a manner that shields them from nearby Class I or Class II industrial uses, framing the building to the adjacent street, maximizing setbacks in accordance with Provincial land use compatibility guidelines, and installing walls, fences, or landscaping to mitigate nuisances, where there is a current, or anticipated need.*

Zoning By-law Amendment

The zoning, *Light Industrial, 21 metre height limit (IL H (21))* is a carryover from when the land was designated Urban Employment Area. The purpose of the zone is to permit

a wide range of low impact light industrial uses, as well as office and office-type uses in a campus-like industrial park setting. The reason certain uses have a size limit is because these uses were meant to be complementary to serve the employees of the Employment Area, the general public in the immediate vicinity, and passing traffic.

Staff understand that you will be making use of Section 93 – One lot for Zoning Purposes.

Guidelines

1. Urban Design Guidelines for Drive-Through Facilities

<https://ottawa.ca/en/urban-design-guidelines-drive-through-facilities>

2. **Urban Design Guidelines for Development Along Arterial Mainstreets**

[Urban Design Guidelines for Development along Arterial Mainstreets | City of Ottawa](#)

Questions and Comments:

1. How much of Building 1 is office and how much is personal services business? In the IL zone there is no size restriction on the office use, only on the personal service business use.
2. If Building 1 is entirely office, then only 13 parking spaces are required. If Building 1 is entirely personal service business use, then 20 parking spaces are required. The different parking space rates for the uses can result in more room for landscaping if the office use is provided rather than the personal services use.
3. Why is Building 1 only one storey? The zoning permits 18 metres building height and the secondary plan contemplates six storey buildings here.
4. The rear lot line abuts an institutional use, so the rear yard setback is 15 metres.
5. The changes to the Zoning By-law provisions you are proposing are a significant departure from the intent of the Light Industrial (IL) zone and are moving the zoning towards an Arterial Mainstreet (AM) Zone, why not do a major rezoning from IL to AM with an urban exception to prohibit residential uses?
6. This development needs to include street-fronting buildings with active frontages.
7. I'm having a hard time with the size of the automotive services buildings and the parking abutting the rear lot line, can the size of the automotive service use be reduced, and the parking relocated?
8. I'm open to considering a reduced interior side yard setback and rear yard setback if a more sensitive approach to the neighboring daycare and church uses are considered. Such as providing a six metres landscape buffer along the

northern interior side yard that permits the preservation of existing trees if they are healthy. And a six metres landscape buffer along the rear lot line where trees can be planted that will visually screen the proposed development from the church.



Figure 7: A capture from geoOttawa where staff have marked up where a larger landscape buffer would be appropriate.

9. I do not support decreasing the width of the landscape area abutting the institutional zone from 3 metres to 1.5 metres. The Zoning By-law does allow for a reduced setback if a 1.4 metre high opaque screen is provided.
10. Please provide further details on queuing spaces in the drive-through to show compliance with Section 112.
11. The site plan shows 6 cars at the order board whereas 7 is required.

Planning Application Fees

The following outlines the application fees (effective April 1, 2023). Please note fees increase each year.

Minor Zoning By-law Amendment

- To remove the 300 sq. metre maximum size applicable to the following uses and instead permit a 682.4 square metres automobile service station, 325.2 square metres restaurants, and 557.5 square metres personal services business.

- To permit a 2.41 metres northern interior side yard setback whereas 7.5 metres is currently required. To permit a 6.26 metres southern interior side yard setback whereas 7.5 metres is currently required.
- To permit a 10.18 metre rear yard setback whereas a 15 metres setback is required.

\$12,244.27 plus an initial Conservation Authority fee of \$ 410*.

* The Conservation Authority will invoice for any additional fees and technical report review as required.

Major Zoning By-law Amendment (Alternative Route)

- To rezone to Arterial Mainstreet with an urban exception prohibiting residential uses and increasing the permitted height to six storeys.

\$ 23,107.27 plus an initial Conservation Authority fee of \$410*

* The Conservation Authority will invoice for any additional fees and technical report review as required.

Site Plan Control - Complex

Type of Application	Planning Fee	Legal Fee	Total
New Complex	\$48,102.27	\$2,882.00 + HST	\$51,358.93

Plus an initial engineering design review and inspection fee (includes HST)

value of Hard and Soft Servicing is less than (<) \$50,000, or	\$1,000, or
value of Hard and Soft Servicing is \$50,000 - \$300,000, or	\$5,000, or
value of Hard and Soft Servicing is greater than (>) \$300,000	\$10,000

Plus, an initial Conservation Authority fee of \$1,120.00*

*The Conservation Authority will invoice for any additional fees and technical report review as required.

** Each planning fee will be reduced by 10 per cent if two or more planning applications listed below are submitted at the same time and for the same lands. Applicable applications are: 30cm Reserve, Demolition Control, Lifting of Holding Zone, Official Plan Amendment, Part Lot Control, Plan of Condominium, Plan of Subdivision, Site Plan

Control, Street/Lane Closure, Street/Lane Opening, and Zoning By-Law Amendment ONLY.

NOTE: Once our new processes kick in, the City will no longer accept concurrent Zoning and Site Plan Control Applications.

Additional information regarding fees related to planning applications can be found [here](#).

Submission Requirements

Attachment 1 is the Applicant Study and Plan List for the Site Plan Application.

Plans are to be standard A1 size (594 mm x 841 mm) or Arch D size (609.6 mm x 914.4 mm) sheets, dimensioned in metric and utilizing an appropriate Metric scale (1:200, 1:250, 1:300, 1:400 or 1:500).

All PDF submitted documents are to be unlocked and flattened.

High Performance Development Standards

The [High Performance Development Standards \(HPDS\)](#) were passed by Council on April 13, 2022. The HPDS will set performance targets for new construction to achieve sustainable development and climate change goals.

At City Council's meeting on May 10, 2023, an update was provided, [High Performance Development Standard Update 2023](#). Council referred the item back to staff and directed staff to bring forward an updated report to Committee no later than Q1 2024. *So, I anticipate that the HPDS will not be applicable until Q1 2024.*

The High-Performance Development Standard (HPDS) is a collection of mandatory and voluntary standards or "metrics" that raise the performance of new building projects to achieve "sustainable and resilient design" objectives. The HPDS consists of three tiers of performance. The standards, also known as 'metrics' in Tier one are mandatory. Tiers two and three contain higher level voluntary standards.

The HPDS apply to new **site plan** and **plan of subdivision** applications.

Once the HPDS are applicable there is an option, for parking areas projects, you may plant one tree for every five parking spaces distributed within or along the border of the parking area, in lieu of reflective paving or completing a shade study.

Urban Design

Molly Smith, MCIP, RPP | Planner II | Molly.Smith@ottawa.ca

1. A Design Brief is required. A Terms of Reference (TOR) for the Brief is attached. All elements highlighted in yellow must be addressed in written and graphic format.
2. The City's [Urban Design Guidelines for Drive-Through Facilities](#) and [Arterial Mainstreets](#) apply to this site. The Design Brief is to address these guidelines and focus on a response to the guidelines related to; landscaping, buffering and interaction with the public realm, and service areas. Please note that the quoted recommended soil volume for trees may be out of date and Forestry's current standards are to apply.
3. The drive-through building should be switched and re-orientated with the office building, this would help with the loading and circulation of the site. If this scheme was explored through the design process, include the analysis in the Design Brief to demonstrate why the layout would not work.
4. The proposed office building should have glazing and windows facing Trim Road.
5. Concerned about the throat length not being long enough and how the parking with drive-through would work, it seems like there would be conflicts.
6. The landscaping and tree planting needs to be increased. The design guidelines for drive-throughs require this when a queuing lane is adjacent to the roadway, this should be screened from the road with a heavier landscape treatment.
7. There should be a treed perimeter around the site with sufficient soil volumes. By providing a stronger tree buffer between the automobile service building and institutional use at the rear (where a setback reduction is sought), this may aid in the rationale for a reduction.
8. The parking should be consolidated near the automobile service station.
9. How come there are three different waste locations? They should be consolidated, molocks need to be screened by landscaping as per the Zoning By-law.
10. Bicycle parking should be near the entrance of the drive-through and office building.

Transportation

Josiane Gervais, P Eng | Project Manager, Infrastructure Approvals |
josiane.gervais@ottawa.ca

1. Follow Transportation Impact Assessment (TIA) Guidelines:
 - i. A TIA is required. Please submit the Scoping report to Josiane.gervais@ottawa.ca at your earliest convenience.
 - ii. Note that a TIA for a rezoning application must account for a worst-case scenario of what would be allowed on the site for the zoning sought.
 - iii. Start this process asap. The application will not be deemed complete until the submission of the draft step 1-4, including the functional draft RMA package (if applicable) and/or monitoring report (if applicable).
 - iv. Request base mapping asap if RMA is required. Contact Engineering Services (<https://ottawa.ca/en/city-hall/planning-and-development/engineering-services>)
 - v. An update to the *TRANS Trip Generation Manual* has been completed (October 2020). This manual is to be utilized for this TIA. A copy of this document can be provided upon request.
2. Clear throat requirements on an arterial is 25m. Ensure this length is provided. The clear throat length is measured from the ends of the driveway curb return radii at the roadway and the point of first conflict on-site.
3. Site falls within 600m radius of Trim LRT Station.
4. As the proposed site is commercial and for general public use, AODA legislation applies.
 - i. Ensure all crosswalks located internally on the site provide a TWSI at the depressed curb, per requirements of the Integrated Accessibility Standards Regulation under the AODA.
 - ii. Clearly define accessible parking stalls and ensure they meet AODA standards (include an access aisle next to the parking stall and a pedestrian curb ramp at the end of the access aisle, as required).
 - iii. Please consider using the City's Accessibility Design Standards, which provide a summary of AODA requirements. <https://ottawa.ca/en/city-hall/creating-equal-inclusive-and-diverse-city/accessibility->

[services/accessibility-design-standards-features#accessibility-design-standards](#)

5. On site plan:
 - i. Ensure site access meets the City's Private Approach Bylaw.
 - ii. Correct the site plan, there is a boulevard between the MUP and the roadway.
 - iii. The Trim Rd access requires a depressed curb parallel to the motor vehicle travel lane on Trim Rd. Since the pedestrian facility on Trim Rd is an asphalt MUP, the entire access should be asphalt. The extent of the MUP within the access should be defined by white (10cm) edge lines and a continuation of the yellow (10cm) MUP centreline.
 - iv. Show all details of the roads abutting the site; include such items as pavement markings, accesses and/or sidewalks.
 - v. Turning movement diagrams required for all accesses showing the largest vehicle to access/egress the site.
 - vi. Turning movement diagrams required for internal movements (loading areas, garbage).
 - vii. Show all curb radii measurements; ensure that all curb radii are reduced as much as possible and fall within TAC guidelines (Figure 8.5.1).
 - viii. Show dimensions for site elements (i.e. lane/aisle widths, access width and throat length, parking stalls, sidewalks, pedestrian pathways, etc.)
 - ix. Parking stalls at the end of dead-end parking aisles require adequate turning around space.

6. As per the City's Noise Control Guidelines, it is best practice to address noise for the following types of spaces: general offices, reception areas, individual or semi-private office, and retail stores. It is therefore recommended to review the roadway noise for the site due to the proximity to Trim Road and to ensure mitigation is provided (as required) so that the workers and visitors of Building 1 are not adversely affected.

Parks

Jessica Button | Planner II (Parks and Facilities Planning) | jessica.button@ottawa.ca

1. Parkland Dedication will be requested in the form of Cash in lieu of Parkland Dedication in accordance with the Parkland Dedication By-law 2022-280 as amended by the Planning
2. The value of the land will be determined by the City's Realty Services Branch. The owner is responsible for any appraisal costs incurred by the City.
3. Please provide Parks & Facilities Planning with a surveyor's note (or equivalent) which specifies the gross land area of the property with your application.

Waste Reduction Workplan Summary

For sites containing one or more buildings with a total GFA greater than 2,000 square metres a Waste Reduction Workplan Summary is required for the construction project as required by O.Reg. 102/94, being "Waste Audits and Waste Reduction Work Plans" made under the Environmental Protection Act, RSO 1990, c E.19, as amended.

Next Steps

You are encouraged to reach out the Ward Councillor, Councillor Matthew Luloff, at matt.luloff@ottawa.ca about the proposal. You may also consider contacting the Cardinal Creek Community Association at communications@cardinalcreek.org and the Cardinal Creek Village Community Association ccvcaorl@gmail.com.

Bill 109

As a result of the Bill 109, *More Homes for Everyone Act, 2022*, for applications for site plan approval and zoning by-law amendments, new processes in respect of pre-application consultation will be put in place. The new processes are anticipated to require a multiple phase pre-application consultation approach before an application will be deemed complete. Applicants who have not filed a complete application by the effective date may be required to undertake further pre-application consultation(s) consistent with the provincial changes. The by-laws to be amended include By-law 2009-320, the Pre-Consultation By-law, By-law 2022-239, the planning fees by-law and By-law 2022-254, the Information and Materials for Planning Application By-law.

I've included a link regarding the changes expected because of Bill 109 on the City's engage website.

https://engage.ottawa.ca/provincial-legislation-planning/news_feed/bill-109-next-steps

A report went to a [Joint Planning and Housing Committee and Agriculture and Rural Affairs Committee](#) on May 30, 2023 and will rise to Council on June 14, 2023, that will speak to the upcoming changes and the implementation date.

Attachments

1. Required Plans and Report Submission
2. High Performance Development Standards Applicant Handout
3. Urban Design Brief Applicable to 1280 Trim Road
4. City of Ottawa, Accessible Design Standard (ADS) Site Plan Checklist

APPENDIX B
Stormwater Management Calculations

LRL Associates Ltd.

Storm Watershed Summary



LRL File No. 230202

Project: Proposed Development-Trim Road Development

Location: 1280 Trim Rd, Ottawa (ON)

Date: October 10, 2024

Designed: M. Longtin

Checked: M. Basnet

Dwg Reference: C701, C702

Pre-Development Catchments

Watershed	C = 0.20	C = 0.70	C = 0.90	Total Area (ha)	Combined C
EWS-01 (uncontrolled)	0.180	0.099	0.045	0.324	0.45
EWS-02 (uncontrolled)	0.090	0.000	0.035	0.125	0.40
EWS-03 (uncontrolled)	0.113	0.000	0.000	0.113	0.20
Total	0.383	0.099	0.080	0.562	0.39

Post-Development Catchments

Watershed	C = 0.20	C = 0.70	C = 0.90	Total Area (ha)	Combined C
WS-01 (controlled)	0.002	0.000	0.074	0.076	0.88
WS-02 (controlled)	0.005	0.000	0.028	0.033	0.79
WS-03 (controlled)	0.003	0.000	0.201	0.204	0.89
WS-04 (controlled)	0.013	0.000	0.025	0.038	0.66
WS-05 (controlled)	0.008	0.000	0.061	0.069	0.82
WS-06 (controlled)	0.011	0.000	0.079	0.090	0.81
WS-07 (uncontrolled)	0.004	0.000	0.017	0.020	0.77
WS-08 (uncontrolled)	0.003	0.000	0.003	0.006	0.53
WS-09 (uncontrolled)	0.004	0.000	0.005	0.009	0.59
WS-10 (uncontrolled)	0.006	0.000	0.002	0.007	0.35
WS-11 (uncontrolled)	0.005	0.000	0.004	0.008	0.51
Total	0.064	0.000	0.498	0.562	0.82



LRL File No. 230202
 Project: Proposed Development-Trim Road Development
 Location: 1280 Trim Rd, Ottawa (ON)
 Date: October 10, 2024
 Designed: M. Longtin
 Checked: M. Basnet
 Drawing Ref.: C701, C702

Stormwater Management
Design Sheet

STORM - 100 YEAR

Runoff Equation

Q = 2.78CIA (L/s)
 C = Runoff coefficient
 I = Rainfall intensity (mm/hr) = A / (Td + C)^B
 A = Area (ha)
 T_c = Time of concentration (min)

Pre-development Stormwater Management (100-Yr)

$I_{100} = 1735.688 / (Td + 6.014)^{0.820}$

A = 1735.688 B = 0.820 C = 6.014

C = 0.39
 I = 178.6 mm/hr
 T_c = 10 min
 Total Area = 0.562 ha
 Release Rate = 108.18 L/s
Allowable Release Rate = 63.12 L/s
 (Allowable Release Rate @5-yr Pre-development Level)

Subcatchment	Area (ha)	Release Rate (L/s)
EWS-01	0.324	72.42
EWS-02	0.125	24.55
EWS-03	0.113	11.21
Total	0.562	108.18

Post-development Stormwater Management

					ΣR _{24.5}	ΣR ₁₀₀
Total Site Area =		0.562	ha	ΣR=	0.82	1.00
Controlled	WS-01	0.076	ha	R=	0.88	1.00
	WS-02	0.204	ha	R=	0.89	1.00
	WS-03	0.033	ha	R=	0.79	0.98
	WS-04	0.038	ha	R=	0.66	0.82
	WS-05	0.069	ha	R=	0.82	1.00
	WS-06	0.090	ha	R=	0.81	1.00
Total Controlled =		0.510	ha	ΣR=	0.84	1.00
Uncontrolled	WS-07	0.020	ha	R=	0.77	0.96
	WS-08	0.006	ha	R=	0.53	0.67
	WS-09	0.009	ha	R=	0.59	0.74
	WS-10	0.007	ha	R=	0.35	0.44
	WS-11	0.008	ha	R=	0.51	0.64
Total Uncontrolled =		0.052	ha	ΣR=	0.61	0.76

Post-development Stormwater Management (100-Yr Uncontrolled)

Time (min)	Intensity (mm/hr)	Un-Controlled Runoff (L/s)	Remarks
10	178.56	9.70	WS-07 (Part of EWS-01 and EWS-03)
10	178.56	2.08	WS-08 (Part of EWS-02 and EWS-03)
10	178.56	3.29	WS-09 (Part of EWS-01 and EWS-02)
10	178.56	1.61	WS-10 (Part of EWS-01)
10	178.56	2.65	WS-11 (Part of EWS-01)
Total		19.33	

Post-development Stormwater Management (100-Yr Controlled)

Time (min)	Intensity (mm/hr)	Controlled Runoff (L/s)	Storage Volume (m ³)	Controlled Release Rate (L/s)	Uncontrolled Runoff (L/s)	Total Release Rate (L/s)
10	178.56	253.36	125.74	43.79	19.33	63.12
15	142.89	202.75	143.07	43.79	15.47	59.26
20	119.95	170.20	151.69	43.79	12.99	56.78
25	103.85	147.35	155.34	43.79	11.24	55.03
30	91.87	130.35	155.81	43.79	9.95	53.74
35	82.58	117.17	154.10	43.79	8.94	52.73
40	75.15	106.62	150.80	43.79	8.14	51.93
45	69.05	97.98	146.30	43.79	7.48	51.27
50	63.95	90.75	140.86	43.79	6.93	50.72
55	59.62	84.60	134.67	43.79	6.46	50.25
60	55.89	79.31	127.87	43.79	6.05	49.84
65	52.65	74.70	120.55	43.79	5.70	49.49
70	49.79	70.65	112.80	43.79	5.39	49.18
75	47.26	67.05	104.67	43.79	5.12	48.91
80	44.99	63.84	96.23	43.79	4.87	48.66
85	42.95	60.95	87.50	43.79	4.65	48.44
90	41.11	58.33	78.53	43.79	4.45	48.24
95	39.43	55.95	69.34	43.79	4.27	48.06
100	37.90	53.78	59.94	43.79	4.10	47.89
105	36.50	51.79	50.38	43.79	3.95	47.74
110	35.20	49.95	40.65	43.79	3.81	47.60
115	34.01	48.25	30.78	43.79	3.68	47.47
120	32.89	46.67	20.77	43.79	3.56	47.35

On-Site Stormwater Detention

Storage required = 155.81 m³
 Surface storage provided = 157.25 m³ (See Dwg C601)



LRL File No. 230202
Project: Proposed Development-Trim Road Development
Location: 1280 Trim Rd, Ottawa (ON)
Date: October 10, 2024
Designed: M. Longtin
Checked: M. Basnet
Drawing Ref.: C701, C702

Stormwater Management
Design Sheet

STORM - 5 YEAR

Runoff Equation

Q = 2.78CIA (L/s)
 C = Runoff coefficient
 I = Rainfall intensity (mm/hr) = $A / (T_d + C)^B$
 A = Area (ha)
 T_c = Time of concentration (min)

Pre-development Stormwater Management (5-Yr)

$I_p = 998.071 / (T_d + 6.053)^{0.814}$ **A = 998.071** **B = 0.814** **C = 6.053**

C = 0.39
 I = 104.2 mm/hr
 T_c = 10 min
 Total Area = 0.562 ha
 Release Rate = **63.12 L/s** (Allowable Release Rate)

Allowable Release Rate = 63.12 L/s

Post-development Stormwater Management

					$\Sigma R_{2.5}$	ΣR_{100}	
		Total Site Area =	0.562	ha	$\Sigma R =$	0.82	1.00
Controlled	WS-01	0.076	ha	R =	0.88	1.00	
	WS-02	0.204	ha	R =	0.89	1.00	
	WS-03	0.033	ha	R =	0.79	0.98	
	WS-04	0.038	ha	R =	0.66	0.82	
	WS-05	0.069	ha	R =	0.82	1.00	
	WS-06	0.090	ha	R =	0.81	1.00	
	Total Controlled =		0.510	ha	$\Sigma R =$	0.84	1.00
Uncontrolled	WS-07	0.020	ha	R =	0.77	0.96	
	WS-08	0.006	ha	R =	0.53	0.67	
	WS-09	0.009	ha	R =	0.59	0.74	
	WS-10	0.007	ha	R =	0.35	0.44	
	WS-11	0.008	ha	R =	0.51	0.64	
	Total Uncontrolled =		0.052	ha	$\Sigma R =$	0.61	0.76

Post-development Stormwater Management (5-Yr Uncontrolled)

Time (min)	Intensity (mm/hr)	Controlled Runoff (L/s)	Remarks
10	104.19	4.53	WS-07 (Part of EWS-01 and EWS-03)
10	104.19	0.97	WS-08 (Part of EWS-02 and EWS-03)
10	104.19	1.54	WS-09 (Part of EWS-01 and EWS-02)
10	104.19	0.75	WS-10 (Part of EWS-01)
10	104.19	1.24	WS-11 (Part of EWS-01)
Total		9.03	

Post-development Stormwater Management (5-Yr Controlled)

Time (min)	Intensity (mm/hr)	Controlled Runoff (L/s)	Storage Volume (m ³)	Controlled Release Rate (L/s)	Uncontrolled Runoff (L/s)	Total Release Rate (L/s)
10	104.19	124.54	48.45	43.79	9.03	52.82
15	83.56	99.87	50.48	43.79	7.24	51.03
20	70.25	83.97	48.22	43.79	6.09	49.88
25	60.90	72.79	43.50	43.79	5.28	49.07
30	53.93	64.46	37.20	43.79	4.67	48.46
35	48.52	57.99	29.82	43.79	4.20	47.99
40	44.18	52.81	21.65	43.79	3.83	47.62
45	40.63	48.56	12.89	43.79	3.52	47.31
50	37.65	45.01	3.65	43.79	3.26	47.05
55	35.12	41.98	0.00	43.79	3.04	46.83
60	32.94	39.38	0.00	43.79	2.85	46.64
65	31.04	37.11	0.00	43.79	2.69	46.48
70	29.37	35.11	0.00	43.79	2.54	46.33
75	27.89	33.33	0.00	43.79	2.42	46.21
80	26.56	31.75	0.00	43.79	2.30	46.09
85	25.37	30.32	0.00	43.79	2.20	45.99
90	24.29	29.03	0.00	43.79	2.10	45.89
95	23.31	27.86	0.00	43.79	2.02	45.81
100	22.41	26.78	0.00	43.79	1.94	45.73
105	21.58	25.80	0.00	43.79	1.87	45.66
110	20.82	24.89	0.00	43.79	1.80	45.59
115	20.12	24.05	0.00	43.79	1.74	45.53
120	19.47	23.27	0.00	43.79	1.69	45.48

On-Site Stormwater Detention

Storage required = 50.48 m³

LRL Associates Ltd.
Storm Design Sheet

	LRL File No. 230202	Storm Design Parameters	
	Project: Proposed Development-Trim Road Development Location: 1280 Trim Rd, Ottawa (ON) Date: October 10, 2024 Designed: M. Longtin Checked: M. Basnet Drawing Reference: C702, C401	Rational Method $Q = 2.78CIA$ $Q = \text{Peak flow (L/s)}$ $A = \text{Drainage area (ha)}$ $C = \text{Runoff coefficient}$ $I = \text{Rainfall intensity (mm/hr)}$	Runoff Coefficient (C) Grass 0.20 Gravel 0.80 Asphalt / rooftop 0.90

LOCATION			AREA (ha)			FLOW					STORM SEWER								
WATERSHED / STREET	From MH	To MH	C = 0.20	C = 0.80	C = 0.90	Indiv. 2.78AC	Accum. 2.78AC	Time of Conc. (min.)	Rainfall Intensity (mm/hr)	Peak Flow Q (L/s)	Controlled Flow Q (L/s)	Pipe Diameter (mm)	Type	Slope (%)	Length (m)	Capacity Full (L/s)	Velocity Full (m/s)	Time of Flow (min.)	Ratio (Q/Q _{FULL})
WS-01	CB01	CBMH03	0.002	0.000	0.074	0.19	0.19	10.00	104.19	19.49		250	PVC	0.50%	24.7	42.0	0.86	0.48	0.46
WS-03	CBMH03	CBMH05	0.003	0.000	0.201	0.51	0.69	10.48	101.72	70.42		375	PVC	0.30%	27.7	96.0	0.87	0.53	0.73
WS-02	CB02	CBMH04	0.005	0.000	0.028	0.07	0.07	10.00	104.19	7.51		250	PVC	0.50%	19.1	42.0	0.86	0.37	0.18
WS-04	CBMH04	CBMH05	0.013	0.000	0.025	0.07	0.14	10.37	102.27	14.43		250	PVC	0.50%	20.4	42.0	0.86	0.40	0.34
WS-05	CBMH05	CBMH06	0.008	0.000	0.061	0.16	0.99	10.93	99.53	98.69		375	PVC	0.50%	17.1	124.0	1.12	0.25	0.80
WS-06	CBMH06	OGS	0.011	0.000	0.079	0.20	1.20	11.18	98.34	117.54	43.79	250	PVC	1.00%	5.8	59.5	1.21	0.08	0.74
	OGS	MH07	0.000	0.000	0.000	0.00	1.20	11.26	97.97	117.10	43.79	250	PVC	2.00%	20.4	84.1	1.71	0.20	0.52
	MH07	Ex. Sewer	0.000	0.000	0.000	0.00	1.20	11.46	97.07	116.02	43.79	250	PVC	2.00%	5.0	84.1	1.71	0.05	0.52

Note
The Peak flow will be controlled by an ICD at the outlet of CBMH06

CSO/STORMWATER MANAGEMENT



HYDROVEX[®] VHV / SVHV
Vertical Vortex Flow Regulator

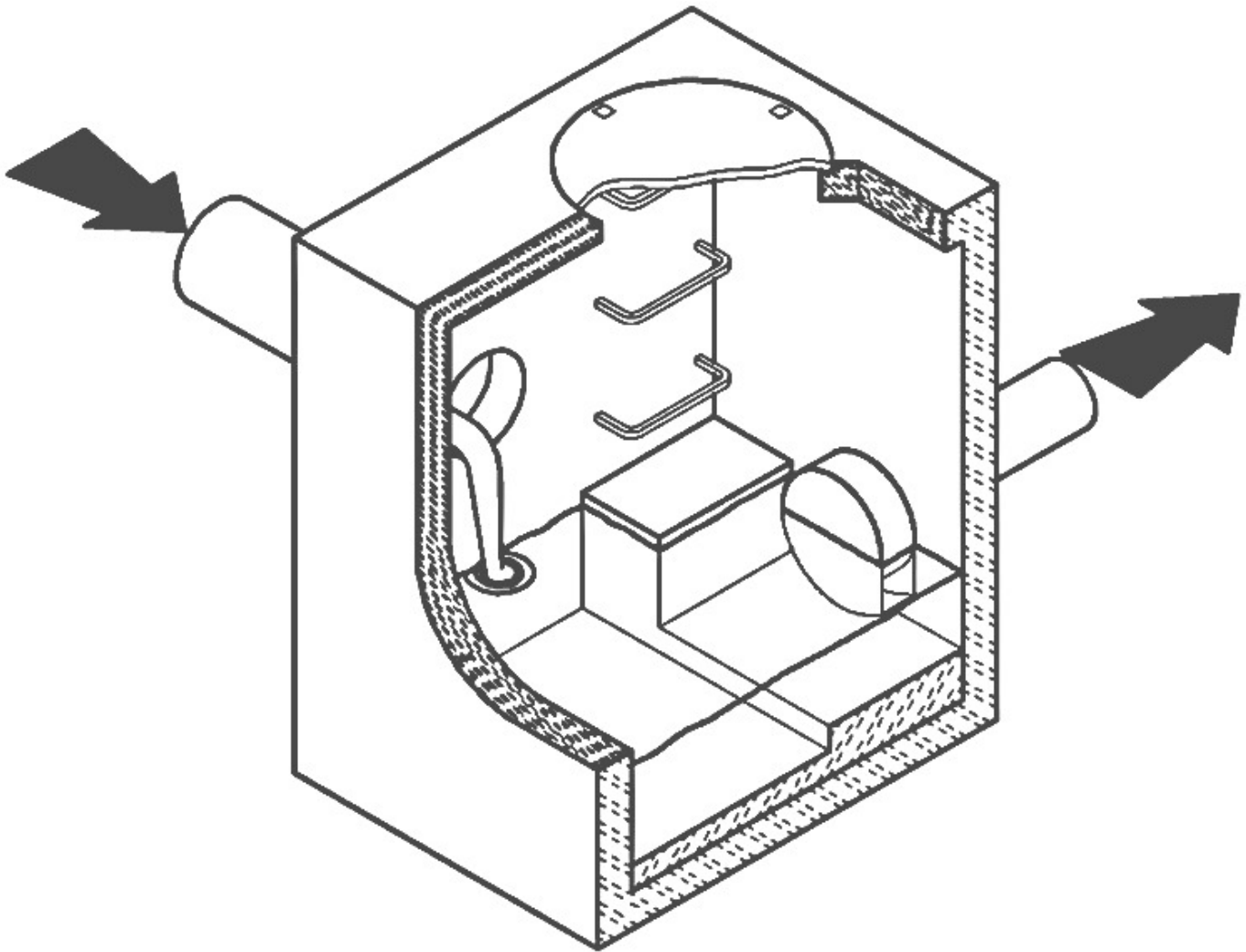

JOHN MEUNIER

HYDROVEX® VHV / SVHV VERTICAL VORTEX FLOW REGULATOR

APPLICATIONS

One of the major problems of urban wet weather flow management is the runoff generated after a heavy rainfall. During a storm, uncontrolled flows may overload the drainage system and cause flooding. Due to increased velocities, sewer pipe wear is increased dramatically and results in network deterioration. In a combined sewer system, the wastewater treatment plant may also experience significant increases in flows during storms, thereby losing its treatment efficiency.

A simple means of controlling excessive water runoff is by controlling excessive flows at their origin (manholes). **John Meunier Inc.** manufactures the **HYDROVEX® VHV / SVHV** line of vortex flow regulators to control stormwater flows in sewer networks, as well as manholes.

The vortex flow regulator design is based on the fluid mechanics principle of the forced vortex. This grants flow regulation without any moving parts, thus reducing maintenance. The operation of the regulator, depending on the upstream head and discharge, switches between orifice flow (gravity flow) and vortex flow. Although the concept is quite simple, over 12 years of research have been carried out in order to get a high performance.

The **HYDROVEX® VHV / SVHV** Vertical Vortex Flow Regulators (refer to **Figure 1**) are manufactured entirely of stainless steel, and consist of a hollow body (1) (in which flow control takes place) and an outlet orifice (7). Two rubber "O" rings (3) seal and retain the unit inside the outlet pipe. Two stainless steel retaining rings (4) are welded on the outlet sleeve to ensure that there is no shifting of the "O" rings during installation and use.

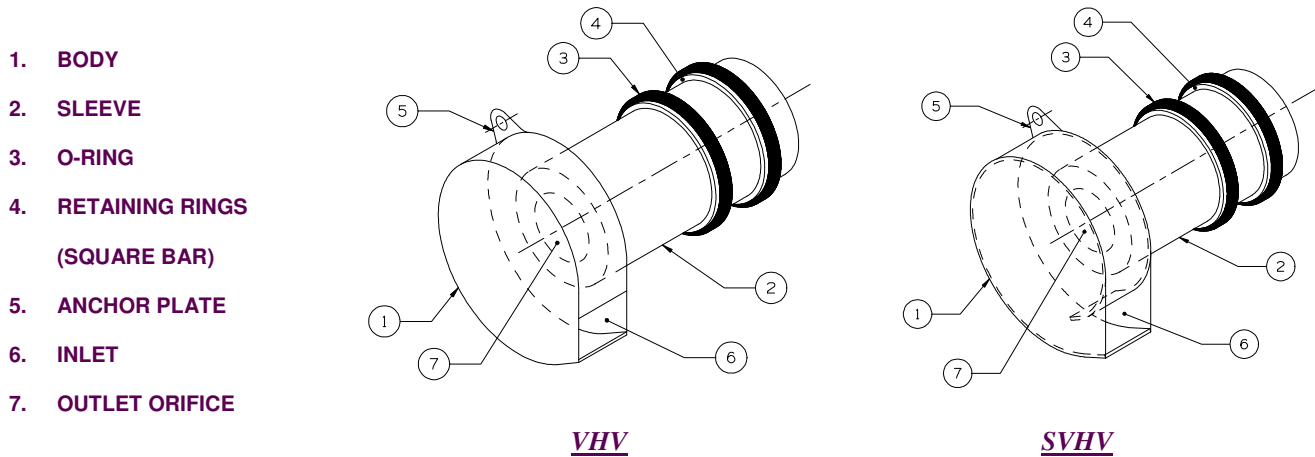

FIGURE 1: HYDROVEX® VHV-SVHV VERTICAL VORTEX FLOW REGULATORS

ADVANTAGES

- The **HYDROVEX® VHV / SVHV** line of flow regulators are manufactured entirely of stainless steel, making them durable and corrosion resistant.
- Having no moving parts, they require minimal maintenance.
- The geometry of the **HYDROVEX® VHV / SVHV** flow regulators allows a control equal to an orifice plate, having a cross section area 4 to 6 times smaller. This decreases the chance of blockage of the regulator, due to sediments and debris found in stormwater flows. **Figure 2** illustrates the comparison between a regulator model 100 SVHV-2 and an equivalent orifice plate. One can see that for the same height of water, the regulator controls a flow approximately four times smaller than an equivalent orifice plate.
- Installation of the **HYDROVEX® VHV / SVHV** flow regulators is quick and straightforward and is performed after all civil works are completed.
- Installation requires no special tools or equipment and may be carried out by any contractor.
- Installation may be carried out in existing structures.

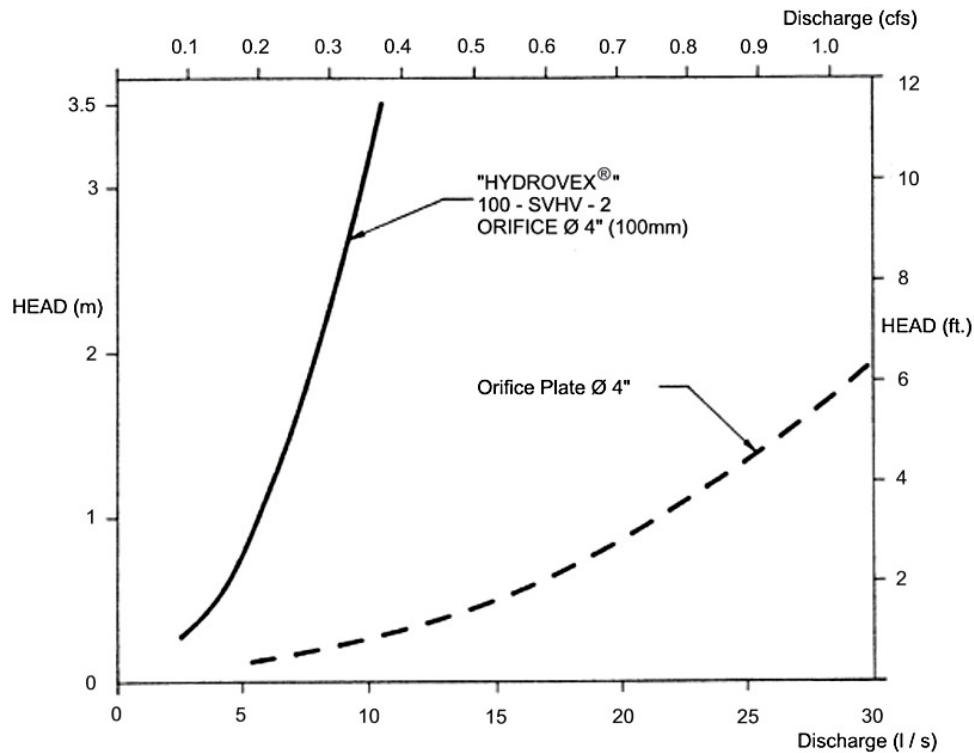

FIGURE 2: DISCHARGE CURVE SHOWING A HYDROVEX® FLOW REGULATOR VS AN ORIFICE PLATE

SELECTION

Selection of a **VHV** or **SVHV** regulator can be easily made using the selection charts found at the back of this brochure (see **Figure 3**). These charts are a graphical representation of the maximum upstream water pressure (head) and the maximum discharge at the manhole outlet. The maximum design head is the difference between the maximum upstream water level and the invert of the outlet pipe. All selections should be verified by John Meunier Inc. personnel prior to fabrication.

Example:

- ✓ Maximum design head 2m (6.56 ft.)
- ✓ Maximum discharge 6 L/s (0.2 cfs)
- ✓ Using **Figure 3** - VHV model required is a **75 VHV-1**

INSTALLATION REQUIREMENTS

All **HYDROVEX®** **VHV** / **SVHV** flow regulators can be installed in circular or square manholes. **Figure 4** gives the various minimum dimensions required for a given regulator. *It is imperative to respect the minimum clearances shown to ensure easy installation and proper functioning of the regulator.*

SPECIFICATIONS

In order to specify a **HYDROVEX**[®] regulator, the following parameters must be defined:

- The model number (ex: 75-VHV-1)
- The diameter and type of outlet pipe (ex: 6" diam. SDR 35)
- The desired discharge (ex: 6 l/s or 0.21 CFS)
- The upstream head (ex: 2 m or 6.56 ft.) *
- The manhole diameter (ex: 36" diam.)
- The minimum clearance "H" (ex: 10 inches)
- The material type (ex: 304 s/s, 11 Ga. standard)

* *Upstream head is defined as the difference in elevation between the maximum upstream water level and the invert of the outlet pipe where the **HYDROVEX**[®] flow regulator is to be installed.*

PLEASE NOTE THAT WHEN REQUESTING A PROPOSAL, WE SIMPLY REQUIRE THAT YOU PROVIDE US WITH THE FOLLOWING:

- *project design flow rate*
- *pressure head*
- *chamber's outlet pipe diameter and type*



Typical VHV model in factory

OPTIONS



FV – SVHV (mounted on sliding plate)



VHV-1-O (standard model with odour control inlet)

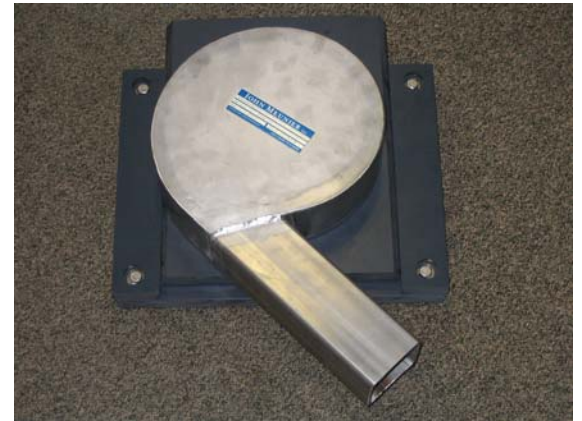

FV – VHV-O (mounted on sliding plate with odour control inlet)



VHV with Gooseneck assembly in existing chamber without minimum release at the bottom



VHV with air vent for minimal slopes



VHV Vertical Vortex Flow Regulator

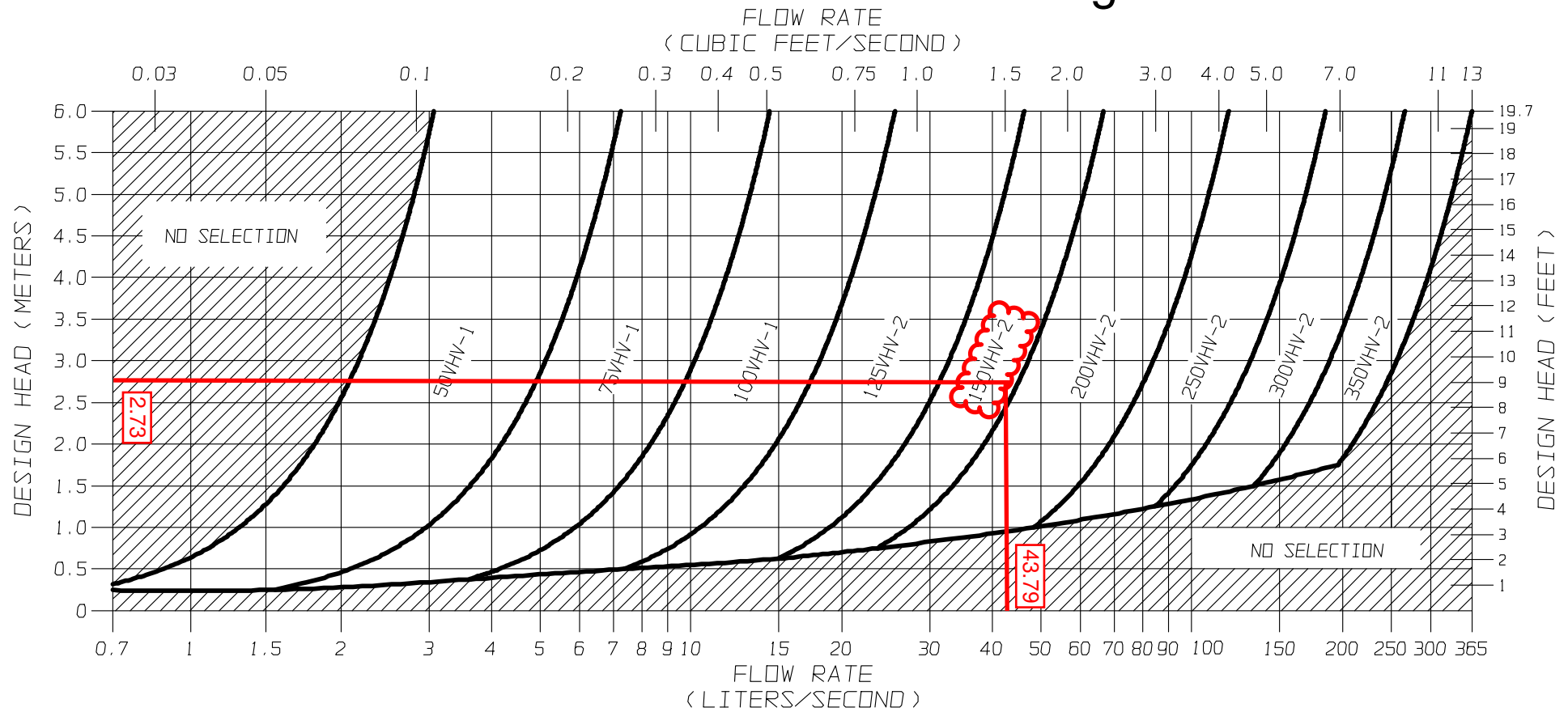
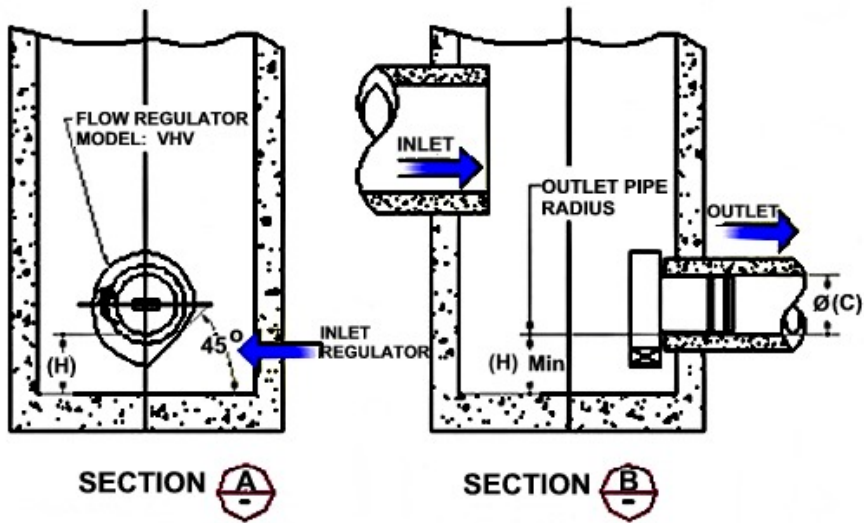
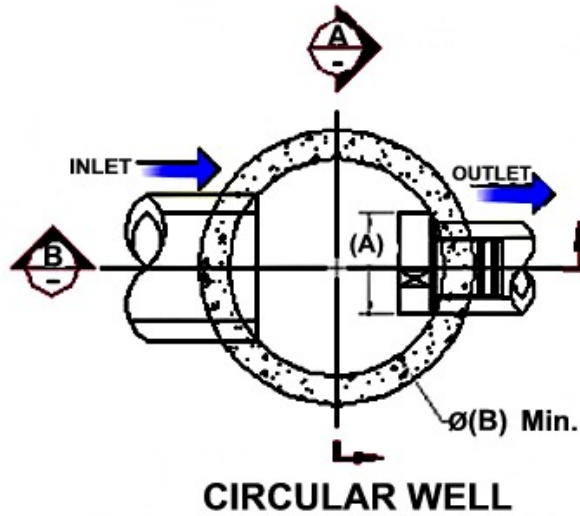

FIGURE 3 - VHV

JOHN MEUNIER

**FLOW REGULATOR TYPICAL INSTALLATION IN CIRCULAR MANHOLE
FIGURE 4 (MODEL VHV)**

Model Number	Regulator Diameter		Minimum Manhole Diameter		Minimum Outlet Pipe Diameter		Minimum Clearance	
	A (mm)	A (in.)	B (mm)	B (in.)	C (mm)	C (in.)	H (mm)	H (in.)
50VHV-1	150	6	600	24	150	6	150	6
75VHV-1	250	10	600	24	150	6	150	6
100VHV-1	325	13	900	36	150	6	200	8
125VHV-2	275	11	900	36	150	6	200	8
150VHV-2	350	14	900	36	150	6	225	9
200VHV-2	450	18	1200	48	200	8	300	12
250VHV-2	575	23	1200	48	250	10	350	14
300VHV-2	675	27	1600	64	250	10	400	16
350VHV-2	800	32	1800	72	300	12	500	20



INSTALLATION

The installation of a **HYDROVEX**[®] regulator may be undertaken once the manhole and piping is in place. Installation consists of simply fitting the regulator into the outlet pipe of the manhole. **John Meunier Inc.** recommends the use of a lubricant on the outlet pipe, in order to facilitate the insertion and orientation of the flow controller.

MAINTENANCE

HYDROVEX[®] regulators are manufactured in such a way as to be maintenance free; however, a periodic inspection (every 3-6 months) is suggested in order to ensure that neither the inlet nor the outlet has become blocked with debris. The manhole should undergo periodically, particularly after major storms, inspection and cleaning as established by the municipality

GUARANTY

The **HYDROVEX**[®] line of **VHV / SVHV** regulators are guaranteed against both design and manufacturing defects for a period of 5 years. Should a unit be defective, **John Meunier Inc.** is solely responsible for either modification or replacement of the unit.

John Meunier Inc.

ISO 9001 : 2008

Head Office

4105 Sartelon

Saint-Laurent (Quebec) Canada H4S 2B3

Tel.: 514-334-7230 www.johnmeunier.com

Fax: 514-334-5070 cs@johnmeunier.com

Ontario Office

2000 Argentia Road, Plaza 4, Unit 430

Mississauga (Ontario) Canada L5N 1W1

Tel.: 905-286-4846 www.johnmeunier.com

Fax: 905-286-0488 ontario@johnmeunier.com

USA Office

2209 Menlo Avenue

Glenside, PA USA 19038

Tel.: 412-417-6614 www.johnmeunier.com

Fax: 215-885-4741 astele@johnmeunier.com



STANDARD OFFLINE Jellyfish Filter Sizing Report

Project Information

Date	Monday, September 25, 2023
Project Name	1280 Trim Rd - Plaza Trim Rd Development
Project Number	230202
Location	Ottawa

Jellyfish Filter Design Overview

This report provides information for the sizing and specification of the Jellyfish Filter. When designed properly in accordance to the guidelines detailed in the Jellyfish Filter Technical Manual, the Jellyfish Filter will exceed the performance and longevity of conventional horizontal bed and granular media filters.

Please see www.ImbriumSystems.com for more information.

Jellyfish Filter System Recommendation

The Jellyfish Filter model JF4-2-1 is recommended to meet the water quality objective by treating a flow of 12.6 L/s, which meets or exceeds 90% of the average annual rainfall runoff volume based on 36 years of OTTAWA MACDONALD-CARTIER INT'L A rainfall data for this site. This model has a sediment capacity of 142 kg, which meets or exceeds the estimated average annual sediment load.

Jellyfish Model	Number of High-Flo Cartridges	Number of Draindown Cartridges	Manhole Diameter (m)	Treatment Flow Rate (L/s)	Sediment Capacity (kg)
JF4-2-1	2	1	1.2	12.6	142

The Jellyfish Filter System

The patented Jellyfish Filter is an engineered stormwater quality treatment technology featuring unique membrane filtration in a compact stand-alone treatment system that removes a high level and wide variety of stormwater pollutants. Exceptional pollutant removal is achieved at high treatment flow rates with minimal head loss and low maintenance costs. Each lightweight Jellyfish Filter cartridge contains an extraordinarily large amount of membrane surface area, resulting in superior flow capacity and pollutant removal capacity.

Maintenance

Regular scheduled inspections and maintenance is necessary to assure proper functioning of the Jellyfish Filter. The maintenance interval is designed to be a minimum of 12 months, but this will vary depending on site loading conditions and upstream pretreatment measures. Quarterly inspections and inspections after all storms beyond the 5-year event are recommended until enough historical performance data has been logged to comfortably initiate an alternative inspection interval.

Please see www.ImbriumSystems.com for more information.

Thank you for the opportunity to present this information to you and your client.

Performance

Jellyfish efficiently captures a high level of Stormwater pollutants, including:

- ☑ 89% of the total suspended solids (TSS) load, including particles less than 5 microns
- ☑ 59% TP removal & 51% TN removal
- ☑ 90% Total Copper, 81% Total Lead, 70% Total Zinc
- ☑ Particulate-bound pollutants such as nutrients, toxic metals, hydrocarbons and bacteria
- ☑ Free oil, Floatable trash and debris

Field Proven Performance

The Jellyfish filter has been field-tested on an urban site with 25 TARP qualifying rain events and field monitored according to the TARP field test protocol, demonstrating:

- A median TSS removal efficiency of 89%, and a median SSC removal of 99%;
- The ability to capture fine particles as indicated by an effluent d50 median of 3 microns for all monitored storm events, and a median effluent turbidity of 5 NTUs;
- A median Total Phosphorus removal of 59%, and a median Total Nitrogen removal of 51%.

Jellyfish Filter Treatment Functions

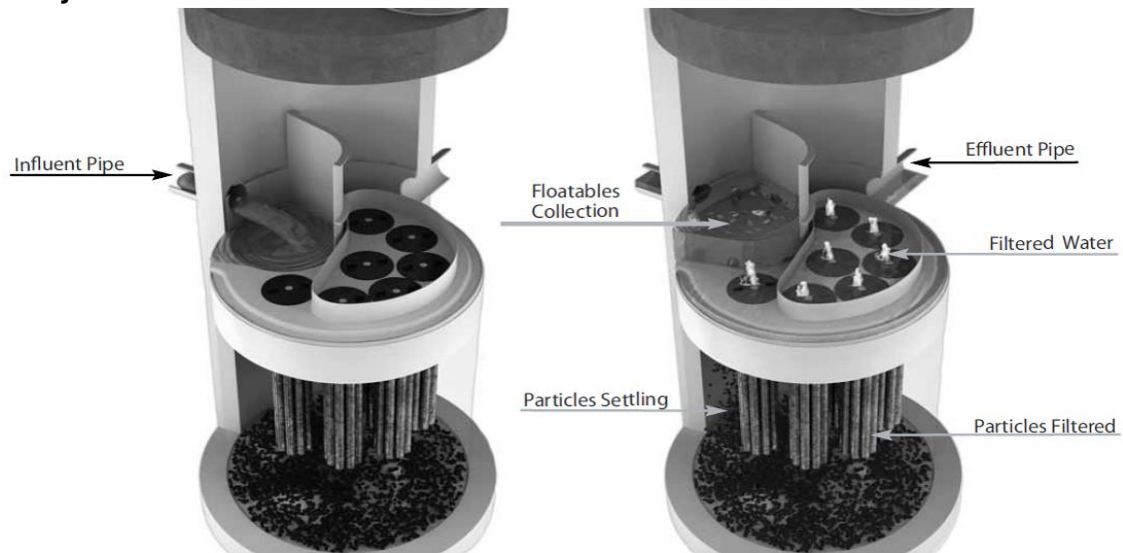

Pre-treatment and Membrane Filtration

Project Information

Date:	Monday, September 25, 2023
Project Name:	1280 Trim Rd - Plaza Trim Rd Development
Project Number:	230202
Location:	Ottawa

Designer Information

Company:	LRL
Contact:	Mohan Basnet
Phone #:	

Notes

controlled area WS-02 to -08 plus uncontrolled WS-01
--

Rainfall

Name:	OTTAWA MACDONALD-CARTIER INT'L A
State:	ON
ID:	6000
Record:	1967 to 2003
Co-ords:	45°19'N, 75°40'W

Drainage Area

Total Area:	0.513 ha
Runoff Coefficient:	0.87

Upstream Detention

Peak Release Rate:	n/a
Pretreatment Credit:	n/a

Design System Requirements

Flow Loading	90% of the Average Annual Runoff based on 36 years of OTTAWA MACDONALD-CARTIER INT'L A rainfall	11.9 L/s
Sediment Loading	Treating 90% of the average annual runoff volume, 2351 m ³ , with a suspended sediment concentration of 60 mg/L.	141 kg

Recommendation

The Jellyfish Filter model JF4-2-1 is recommended to meet the water quality objective by treating a flow of 12.6 L/s, which meets or exceeds 90% of the average annual rainfall runoff volume based on 36 years of OTTAWA MACDONALD-CARTIER INT'L A rainfall data for this site. This model has a sediment capacity of 142 kg, which meets or exceeds the estimated average annual sediment load.

Jellyfish Model	Number of High-Flo Cartridges	Number of Draindown Cartridges	Manhole Diameter (m)	Wet Vol Below Deck (L)	Sump Storage (m ³)	Oil Capacity (L)	Treatment Flow Rate (L/s)	Sediment Capacity (kg)
JF4-1-1	1	1	1.2	2313	0.34	379	7.6	85
JF4-2-1	2	1	1.2	2313	0.34	379	12.6	142
JF6-3-1	3	1	1.8	5205	0.79	848	17.7	199
JF6-4-1	4	1	1.8	5205	0.79	848	22.7	256
JF6-5-1	5	1	1.8	5205	0.79	848	27.8	313
JF6-6-1	6	1	1.8	5205	0.79	848	28.6	370
JF8-6-2	6	2	2.4	9252	1.42	1469	35.3	398
JF8-7-2	7	2	2.4	9252	1.42	1469	40.4	455
JF8-8-2	8	2	2.4	9252	1.42	1469	45.4	512
JF8-9-2	9	2	2.4	9252	1.42	1469	50.5	569
JF8-10-2	10	2	2.4	9252	1.42	1469	50.5	626
JF10-11-3	11	3	3.0	14456	2.21	2302	63.1	711
JF10-12-3	12	3	3.0	14456	2.21	2302	68.2	768
JF10-12-4	12	4	3.0	14456	2.21	2302	70.7	796
JF10-13-4	13	4	3.0	14456	2.21	2302	75.7	853
JF10-14-4	14	4	3.0	14456	2.21	2302	78.9	910
JF10-15-4	15	4	3.0	14456	2.21	2302	78.9	967
JF10-16-4	16	4	3.0	14456	2.21	2302	78.9	1024
JF10-17-4	17	4	3.0	14456	2.21	2302	78.9	1081
JF10-18-4	18	4	3.0	14456	2.21	2302	78.9	1138
JF10-19-4	19	4	3.0	14456	2.21	2302	78.9	1195
JF12-20-5	20	5	3.6	20820	3.2	2771	113.6	1280
JF12-21-5	21	5	3.6	20820	3.2	2771	113.7	1337
JF12-22-5	22	5	3.6	20820	3.2	2771	113.7	1394
JF12-23-5	23	5	3.6	20820	3.2	2771	113.7	1451
JF12-24-5	24	5	3.6	20820	3.2	2771	113.7	1508
JF12-25-5	25	5	3.6	20820	3.2	2771	113.7	1565
JF12-26-5	26	5	3.6	20820	3.2	2771	113.7	1622
JF12-27-5	27	5	3.6	20820	3.2	2771	113.7	1679

Jellyfish Filter Design Notes

- Typically the Jellyfish Filter is designed in an offline configuration, as all stormwater filter systems will perform for a longer duration between required maintenance services when designed and applied in off-line configurations. Depending on the design parameters, an optional internal bypass may be incorporated into the Jellyfish Filter, however note the inspection and maintenance frequency should be expected to increase above that of an off-line system. Speak to your local representative for more information.

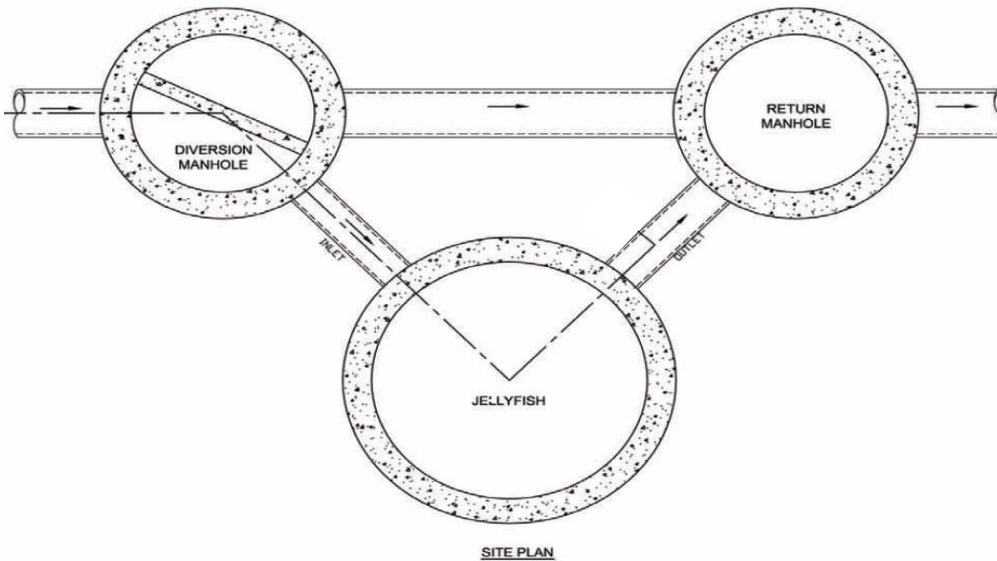

Jellyfish Filter Typical Layout

- Typically, 18 inches (457 mm) of driving head is designed into the system, calculated as the difference in elevation between the top of the diversion structure weir and the invert of the Jellyfish Filter outlet pipe. Alternative driving head values can be designed as 12 to 24 inches (305 to 610mm) depending on specific site requirements, requiring additional sizing and design assistance.
- Typically, the Jellyfish Filter is designed with the inlet pipe configured 6 inches (150 mm) above the outlet invert elevation. However, depending on site parameters this can vary to an optional configuration of the inlet pipe entering the unit below the outlet invert elevation.
- The Jellyfish Filter can accommodate multiple inlet pipes within certain restrictions.
- While the optional inlet below deck configuration offers 0 to 360 degree flexibility between the inlet and outlet pipe, typical systems conform to the following:

Model Diameter (m)	Minimum Angle Inlet / Outlet Pipes	Minimum Inlet Pipe Diameter (mm)	Minimum Outlet Pipe Diameter (mm)
1.2	62°	150	200
1.8	59°	200	250
2.4	52°	250	300
3.0	48°	300	450
3.6	40°	300	450

- The Jellyfish Filter can be built at all depths of cover generally associated with conventional stormwater conveyance systems. For sites that require minimal depth of cover for the stormwater infrastructure, the Jellyfish Filter can be applied in a shallow application using a hatch cover. The general minimum depth of cover is 36 inches (915 mm) from top of the underslab to outlet invert.
- If driving head calculations account for water elevation during submerged conditions the Jellyfish Filter will function effectively under submerged conditions.
- Jellyfish Filter systems may incorporate grated inlets depending on system configuration.
- For sites with water quality treatment flow rates or mass loadings that exceed the design flow rate of the largest standard Jellyfish Filter manhole models, systems can be designed that hydraulically connect multiple Jellyfish Filters in series or alternatively Jellyfish Vault units can be designed.

STANDARD SPECIFICATION STORMWATER QUALITY – MEMBRANE FILTRATION TREATMENT DEVICE

PART 1 – GENERAL

1.1 WORK INCLUDED

Specifies requirements for construction and performance of an underground stormwater quality membrane filtration treatment device that removes pollutants from stormwater runoff through the unit operations of sedimentation, floatation, and membrane filtration.

1.2 REFERENCE STANDARDS

ASTM C 891: Specification for Installation of Underground Precast Concrete Utility Structures
ASTM C 478: Specification for Precast Reinforced Concrete Manhole Sections
ASTM C 443: Specification for Joints for Concrete Pipe and Manholes, Using Rubber Gaskets
ASTM D 4101: Specification for Copolymer steps construction

CAN/CSA-A257.4-M92

Joints for Circular Concrete Sewer and Culvert Pipe, Manhole Sections and Fittings Using Rubber Gaskets

CAN/CSA-A257.4-M92

Precast Reinforced Circular Concrete Manhole Sections, Catch Basins and Fittings

Canadian Highway Bridge Design Code

1.3 SHOP DRAWINGS

Shop drawings for the structure and performance are to be submitted with each order to the contractor. Contractor shall forward shop drawing submittal to the consulting engineer for approval. Shop drawings are to detail the structure's precast concrete and call out or note the fiberglass (FRP) internals/components.

1.4 PRODUCT SUBSTITUTIONS

No product substitutions shall be accepted unless submitted 10 days prior to project bid date, or as directed by the engineer of record. Submissions for substitutions require review and approval by the Engineer of Record, for hydraulic performance, impact to project designs, equivalent treatment performance, and any required project plan and report (hydrology/hydraulic, water quality, stormwater pollution) modifications that would be required by the approving jurisdictions/agencies. Contractor to coordinate with the Engineer of Record any applicable modifications to the project estimates of cost, bonding amount determinations, plan check fees for changes to approved documents, and/or any other regulatory requirements resulting from the product substitution.

1.5 HANDLING AND STORAGE

Prevent damage to materials during storage and handling.

PART 2 – PRODUCTS

2.1 GENERAL

- 2.1.1 The device shall be a cylindrical or rectangular, all concrete structure (including risers), constructed from precast concrete riser and slab components or monolithic precast structure(s), installed to conform to ASTM C 891 and to any required state highway, municipal or local specifications; whichever is more stringent. The device shall be watertight.
- 2.1.2 Cartridge Deck The cylindrical concrete device shall include a fiberglass deck. The rectangular concrete device shall include a coated aluminum deck. In either instance, the insert shall be bolted and sealed watertight inside the precast concrete chamber. The deck shall serve as: (a) a horizontal divider between the lower treatment zone and the upper treated effluent zone; (b) a deck for attachment of filter cartridges such that the membrane filter elements of each cartridge extend into the lower treatment zone; (c) a platform for maintenance workers to service the filter cartridges (maximum manned weight = 450 pounds (204 kg)); (d) a conduit for conveyance of treated water to the effluent pipe.
- 2.1.3 Membrane Filter Cartridges Filter cartridges shall be comprised of reusable cylindrical membrane filter elements connected to a perforated head plate. The number of membrane filter elements per cartridge shall be a minimum of eleven 2.75-inch (70-mm) diameter elements. The length of each filter element shall be a minimum 15 inches (381 mm). Each cartridge shall be fitted into the cartridge deck by insertion into a cartridge receptacle that is permanently mounted into the cartridge deck. Each cartridge shall be secured by a cartridge lid that is threaded onto the receptacle, or similar mechanism to secure the cartridge into the deck. The maximum treatment flow rate of a filter cartridge shall be controlled by an orifice in the cartridge lid, or on the individual cartridge itself, and based on a design flux rate (surface loading rate) determined by the maximum treatment flow rate per unit of filtration membrane surface area. The maximum design flux rate shall be 0.21 gpm/ft² (0.142 lps/m²).

Each membrane filter cartridge shall allow for manual installation and removal. Each filter cartridge shall have filtration membrane surface area and dry installation weight as follows (if length of filter cartridge is between those listed below, the surface area and weight shall be proportionate to the next length shorter and next length longer as shown below):

Filter Cartridge Length (in / mm)	Minimum Filtration Membrane Surface Area (ft ² / m ²)	Maximum Filter Cartridge Dry Weight (lbs / kg)
15	106 / 9.8	10.5 / 4.8
27	190 / 17.7	15.0 / 6.8
40	282 / 26.2	20.5 / 9.3
54	381 / 35.4	25.5 / 11.6

- 2.1.4 Backwashing Cartridges The filter device shall have a weir extending above the cartridge deck, or other mechanism, that encloses the high flow rate filter cartridges when placed in their respective cartridge receptacles within the cartridge deck. The weir, or other mechanism, shall collect a pool of filtered water during inflow events that backwashes the high flow rate cartridges when the inflow

event subsides. All filter cartridges and membranes shall be reusable and allow for the use of filtration membrane rinsing procedures to restore flow capacity and sediment capacity; extending cartridge service life.

- 2.1.5 Maintenance Access to Captured Pollutants The filter device shall contain an opening(s) that provides maintenance access for removal of accumulated floatable pollutants and sediment, removal of and replacement of filter cartridges, cleaning of the sump, and rinsing of the deck. Access shall have a minimum clear vertical clear space over all of the filter cartridges. Filter cartridges shall be able to be lifted straight vertically out of the receptacles and deck for the entire length of the cartridge.
- 2.1.6 Bend Structure The device shall be able to be used as a bend structure with minimum angles between inlet and outlet pipes of 90-degrees or less in the stormwater conveyance system.
- 2.1.7 Double-Wall Containment of Hydrocarbons The cylindrical precast concrete device shall provide double-wall containment for hydrocarbon spill capture by a combined means of an inner wall of fiberglass, to a minimum depth of 12 inches (305 mm) below the cartridge deck, and the precast vessel wall.
- 2.1.8 Baffle The filter device shall provide a baffle that extends from the underside of the cartridge deck to a minimum length equal to the length of the membrane filter elements. The baffle shall serve to protect the membrane filter elements from contamination by floatables and coarse sediment. The baffle shall be flexible and continuous in cylindrical configurations, and shall be a straight concrete or aluminum wall in rectangular configurations.
- 2.1.9 Sump The device shall include a minimum 24 inches (610 mm) of sump below the bottom of the cartridges for sediment accumulation, unless otherwise specified by the design engineer. Depths less than 24 inches may have an impact on the total performance and/or longevity between cartridge maintenance/replacement of the device.

2.2 PRECAST CONCRETE SECTIONS

All precast concrete components shall be manufactured to a minimum live load of HS-20 truck loading or greater based on local regulatory specifications, unless otherwise modified or specified by the design engineer, and shall be watertight.

2.3 JOINTS All precast concrete manhole configuration joints shall use nitrile rubber gaskets and shall meet the requirements of ASTM C443, Specification C1619, Class D or engineer approved equal to ensure oil resistance. Mastic sealants or butyl tape are not an acceptable alternative.

2.4 GASKETS Only profile neoprene or nitrile rubber gaskets in accordance to CSA A257.3-M92 will be accepted. Mastic sealants, butyl tape or Con Seal CS-101 are not acceptable gasket materials.

2.5 FRAME AND COVER Frame and covers must be manufactured from cast-iron or other composite material tested to withstand H-20 or greater design loads, and as approved by the

local regulatory body. Frames and covers must be embossed with the name of the device manufacturer or the device brand name.

- 2.6 DOORS AND HATCHES If provided shall meet designated loading requirements or at a minimum for incidental vehicular traffic.
- 2.7 CONCRETE All concrete components shall be manufactured according to local specifications and shall meet the requirements of ASTM C 478.
- 2.8 FIBERGLASS The fiberglass portion of the filter device shall be constructed in accordance with the following standard: ASTM D-4097: Contact Molded Glass Fiber Reinforced Chemical Resistant Tanks.
- 2.9 STEPS Steps shall be constructed according to ASTM D4101 of copolymer polypropylene, and be driven into preformed or pre-drilled holes after the concrete has cured, installed to conform to applicable sections of state, provincial and municipal building codes, highway, municipal or local specifications for the construction of such devices.
- 2.10 INSPECTION All precast concrete sections shall be inspected to ensure that dimensions, appearance and quality of the product meet local municipal specifications and ASTM C 478.

PART 3 – PERFORMANCE

3.1 GENERAL

- 3.1.1 Verification – The stormwater quality filter must be verified in accordance with ISO 14034:2016 Environmental management – Environmental technology verification (ETV).
- 3.1.2 Function - The stormwater quality filter treatment device shall function to remove pollutants by the following unit treatment processes; sedimentation, floatation, and membrane filtration.
- 3.1.3 Pollutants - The stormwater quality filter treatment device shall remove oil, debris, trash, coarse and fine particulates, particulate-bound pollutants, metals and nutrients from stormwater during runoff events.
- 3.1.4 Bypass - The stormwater quality filter treatment device shall typically utilize an external bypass to divert excessive flows. Internal bypass systems shall be equipped with a floatables baffle, and must avoid passage through the sump and/or cartridge filtration zone.
- 3.1.5 Treatment Flux Rate (Surface Loading Rate) – The stormwater quality filter treatment device shall treat 100% of the required water quality treatment flow based on a maximum design treatment flux rate (surface loading rate) across the membrane filter cartridges of 0.21 gpm/ft² (0.142 lps/m²).

3.2 FIELD TEST PERFORMANCE

At a minimum, the stormwater quality filter device shall have been field tested and verified with a minimum 25 TARP qualifying storm events and field monitoring shall have been conducted according to the TARP 2009 NJDEP TARP field test protocol, and have received NJCAT verification.

- 3.2.1 Suspended Solids Removal - The stormwater quality filter treatment device shall have demonstrated a minimum median TSS removal efficiency of 85% and a minimum median SSC removal efficiency of 95%.
- 3.2.2 Runoff Volume – The stormwater quality filter treatment device shall be engineered, designed, and sized to treat a minimum of 90 percent of the annual runoff volume determined from use of a minimum 15-year rainfall data set.
- 3.2.3 Fine Particle Removal - The stormwater quality filter treatment device shall have demonstrated the ability to capture fine particles as indicated by a minimum median removal efficiency of 75% for the particle fraction less than 25 microns, an effluent d_{50} of 15 microns or lower for all monitored storm events.
- 3.2.4 Turbidity Reduction - The stormwater quality filter treatment device shall have demonstrated the ability to reduce the turbidity from influent from a range of 5 to 171 NTU to an effluent turbidity of 15 NTU or lower.
- 3.2.5 Nutrient (Total Phosphorus & Total Nitrogen) Removal - The stormwater quality filter treatment device shall have demonstrated a minimum median Total Phosphorus removal of 55%, and a minimum median Total Nitrogen removal of 50%.
- 3.2.6 Metals (Total Zinc & Total Copper) Removal - The stormwater quality filter treatment device shall have demonstrated a minimum median Total Zinc removal of 55%, and a minimum median Total Copper removal of 85%.

3.3 INSPECTION and MAINTENANCE

The stormwater quality filter device shall have the following features:

- 3.3.1 Durability of membranes are subject to good handling practices during inspection and maintenance (removal, rinsing, and reinsertion) events, and site specific conditions that may have heavier or lighter loading onto the cartridges, and pollutant variability that may impact the membrane structural integrity. Membrane maintenance and replacement shall be in accordance with manufacturer's recommendations.
- 3.3.2 Inspection which includes trash and floatables collection, sediment depth determination, and visible determination of backwash pool depth shall be easily conducted from grade (outside the structure).
- 3.3.3 Manual rinsing of the reusable filter cartridges shall promote restoration of the flow capacity and sediment capacity of the filter cartridges, extending cartridge service life.

- 3.3.4 The filter device shall have a minimum 12 inches (305 mm) of sediment storage depth, and a minimum of 12 inches between the top of the sediment storage and bottom of the filter cartridge tentacles, unless otherwise specified by the design engineer. Variances may have an impact on the total performance and/or longevity between cartridge maintenance/replacement of the device.
- 3.3.5 Sediment removal from the filter treatment device shall be able to be conducted using a standard maintenance truck and vacuum apparatus, and a minimum one point of entry to the sump that is unobstructed by filter cartridges.
- 3.3.6 Maintenance access shall have a minimum clear height that provides suitable vertical clear space over all of the filter cartridges. Filter cartridges shall be able to be lifted straight vertically out of the receptacles and deck for the entire length of the cartridge.
- 3.3.7 Filter cartridges shall be able to be maintained without the requirement of additional lifting equipment.

PART 4 – EXECUTION

4.1 INSTALLATION

4.1.1 PRECAST DEVICE CONSTRUCTION SEQUENCE

The installation of a watertight precast concrete device should conform to ASTM C 891 and to any state highway, municipal or local specifications for the construction of manholes, whichever is more stringent. Selected sections of a general specification that are applicable are summarized below.

4.1.1.1 The watertight precast concrete device is installed in sections in the following sequence:

- aggregate base
- base slab
- treatment chamber and cartridge deck riser section(s)
- bypass section
- connect inlet and outlet pipes
- concrete riser section(s) and/or transition slab (if required)
- maintenance riser section(s) (if required)
- frame and access cover

4.1.2 The precast base should be placed level at the specified grade. The entire base should be in contact with the underlying compacted granular material. Subsequent sections, complete with joint seals, should be installed in accordance with the precast concrete manufacturer's recommendations.

4.1.3 Adjustment of the stormwater quality treatment device can be performed by lifting the upper sections free of the excavated area, re-leveling the base, and re-installing the sections. Damaged sections and gaskets should be repaired or replaced as necessary to restore original condition and watertight seals. Once the stormwater quality treatment device has been constructed, any/all lift holes must be plugged watertight with mortar or non-shrink grout.

- 4.1.4 Inlet and Outlet Pipes Inlet and outlet pipes should be securely set into the device using approved pipe seals (flexible boot connections, where applicable) so that the structure is watertight, and such that any pipe intrusion into the device does not impact the device functionality.
- 4.1.5 Frame and Cover Installation Adjustment units (e.g. grade rings) should be installed to set the frame and cover at the required elevation. The adjustment units should be laid in a full bed of mortar with successive units being joined using sealant recommended by the manufacturer. Frames for the cover should be set in a full bed of mortar at the elevation specified.

4.2 MAINTENANCE ACCESS WALL

In some instances the Maintenance Access Wall, if provided, shall require an extension attachment and sealing to the precast wall and cartridge deck at the job site, rather than at the precast facility. In this instance, installation of these components shall be performed according to instructions provided by the manufacturer.

4.3 FILTER CARTRIDGE INSTALLATION Filter cartridges shall be installed in the cartridge deck only after the construction site is fully stabilized and in accordance with the manufacturer's guidelines and recommendations. Contractor to contact the manufacturer to schedule cartridge delivery and review procedures/requirements to be completed to the device prior to installation of the cartridges and activation of the system.

PART 5 – QUALITY ASSURANCE

5.1 FILTER CARTRIDGE INSTALLATION Manufacturer shall coordinate delivery of filter cartridges and other internal components with contractor. Filter cartridges shall be delivered and installed complete after site is stabilized and unit is ready to accept cartridges. Unit is ready to accept cartridges after it has been cleaned out and any standing water, debris, and other materials have been removed. Contractor shall take appropriate action to protect the filter cartridge receptacles and filter cartridges from damage during construction, and in accordance with the manufacturer's recommendations and guidance. For systems with cartridges installed prior to full site stabilization and prior to system activation, the contractor can plug inlet and outlet pipes to prevent stormwater and other influent from entering the device. Plugs must be removed during the activation process.

5.2 INSPECTION AND MAINTENANCE

5.2.1 The manufacturer shall provide an Owner's Manual upon request.

5.2.2 After construction and installation, and during operation, the device shall be inspected and cleaned as necessary based on the manufacturer's recommended inspection and maintenance guidelines and the local regulatory agency/body.

5.3 REPLACEMENT FILTER CARTRIDGES When replacement membrane filter elements and/or other parts are required, only membrane filter elements and parts approved by the manufacturer for use with the stormwater quality filter device shall be installed.

END OF SECTION

IMBRIUM PRODUCTS JELLYFISH FILTER 40 DRAWINGS & DETAILS STANDARD DETAILS JELLYFISH FILTER - OFFLINE JELLYFISH FILTER - OFFLINE JELLYFISH FILTER - OFFLINE DIVERSION MANHOLE.DWG 4/16/2019 9:16 AM

- GENERAL NOTES:**
- ALL DIMENSIONS INDICATED ARE IN MILLIMETERS (INCHES) UNLESS OTHERWISE SPECIFIED.
 - JELLYFISH STRUCTURE INLET AND OUTLET PIPE SIZE AND ORIENTATION SHOWN FOR INFORMATIONAL PURPOSES ONLY.
 - UNLESS OTHERWISE NOTED, BYPASS INFRASTRUCTURE, SUCH AS ALL UPSTREAM DIVERSION STRUCTURES, CONNECTING STRUCTURES, OR PIPE CONDUITS CONNECTING TO COMPLETE THE JELLYFISH SYSTEM SHALL BE PROVIDED AND ADDRESSED SEPARATELY.
 - DRAWING FOR INFORMATION PURPOSES ONLY. REFER TO ENGINEER'S SITE/UTILITY PLAN FOR STRUCTURE ORIENTATION.
 - NO PRODUCT SUBSTITUTIONS SHALL BE ACCEPTED UNLESS SUBMITTED 10 DAYS PRIOR TO PROJECT BID DATE, OR AS DIRECTED BY THE ENGINEER OF RECORD.

JELLYFISH STRUCTURE & DESIGN NOTES:

- 457 MM Ø (18") MAINTENANCE ACCESS WALL TO BE USED FOR CLEANOUT AND ACCESS BELOW CARTRIDGE DECK.
- CASTINGS OR DOORS OF THE JELLYFISH MANHOLE STRUCTURE TO EXTEND TO DESIGN FINISH GRADE. DEPTHS IN EXCESS OF 3.65 M (12') MAY REQUIRE THE DESIGN AND INSTALLATION OF INTERMEDIATE SAFETY GRATES OR OTHER STRUCTURAL ELEMENTS.
- CASTINGS AND GRADE RINGS, OR DOORS AND DOOR RISERS, OR BOTH, SHALL BE GROUTED FOR WATERTIGHTNESS. STRUCTURE SHALL MEET AASHTO HS-20, ASSUMING EARTH COVER OF 0' - 3', AND GROUNDWATER ELEVATION AT, OR BELOW, THE OUTLET PIPE INVERT ELEVATION. ENGINEER OF RECORD TO CONFIRM ACTUAL GROUNDWATER ELEVATION. CASTINGS SHALL MEET AASHTO M306 LOAD RATING AND BE CAST WITH THE IMBRIUM LOGO.
- ALL STRUCTURAL SECTIONS AND PARTS TO MEET OR EXCEED ASTM C-478, ASTM C-443, AND ASTM D-4097 CORRESPONDING TO AASHTO SPECIFICATIONS, AND ANY OTHER SITE OR LOCAL STANDARDS.
- CONCRETE RISER SECTIONS FROM BOTTOM TO TOP WILL BE ADDED AS REQUIRED INCLUDING TRANSITION PIECES TO SMALLER DIAMETER RISERS FOR SURFACE ACCESSES WHERE WARRANTED BY SERVICING DEPTH.
- IF MINIMUM DEPTH FROM TOP OF CARTRIDGE DECK TO BOTTOM OF STRUCTURAL TOP SLAB CANNOT BE ACHIEVED DUE TO PIPING INVERT ELEVATIONS OR OTHER SITE CONSTRAINTS. ALTERNATIVE HATCH CONFIGURATIONS MAY BE AVAILABLE. HATCH DOORS SHOULD BE SIZED TO PROVIDE FULL ACCESS ABOVE THE CARTRIDGES TO ACCOMMODATE MAINTENANCE.
- STEPS TO BE APPROXIMATELY 330 MM (13") APART AND DIMENSIONS MUST MEET LOCAL STANDARDS. STEPS MUST BE INSTALLED AFTER CARTRIDGE DECK IS IN PLACE.
- CONFIGURATION OF INLET AND OUTLET PIPE CAN VARY TO MEET SITE'S NEEDS.
- IT IS THE RESPONSIBILITY OF OTHERS TO PROPERLY PROTECT THE TREATMENT DEVICE, AND KEEP THE DEVICE OFFLINE DURING CONSTRUCTION. FILTER CARTRIDGES SHALL NOT BE INSTALLED UNTIL THE PROJECT SITE IS CLEAN AND FREE OF DEBRIS, BY OTHERS. THE PROJECT SITE INCLUDES ANY SURFACE THAT CONTRIBUTES STORM DRAINAGE TO THE TREATMENT DEVICE. CARTRIDGES SHALL BE FURNISHED NEW, AT THE TIME OF FINAL ACCEPTANCE.
- THIS DRAWING MUST BE VIEWED IN CONJUNCTION WITH THE STANDARD JELLYFISH SPECIFICATION, AND STORMWATER QUALITY FILTER TREATMENT JELLYFISH DOCUMENTS.

INSTALLATION NOTES

- ANY SUB-BASE, BACKFILL DEPTH, AND/OR ANTI-FLOTATION PROVISIONS ARE SITE-SPECIFIC DESIGN CONSIDERATIONS AND SHALL BE SPECIFIED BY ENGINEER OF RECORD.
- CONTRACTOR TO PROVIDE EQUIPMENT WITH SUFFICIENT LIFTING AND REACH CAPACITY TO LIFT AND SET THE STRUCTURE (LIFTING CLUTCHES PROVIDED)
- CONTRACTOR WILL INSTALL AND LEVEL THE STRUCTURE, SEALING THE JOINTS, LINE ENTRY AND EXIT POINTS (NON-SHRINK GROUT WITH APPROVED WATERSTOP OR FLEXIBLE BOOT)
- CONTRACTOR TO TAKE APPROPRIATE MEASURES TO PROTECT CARTRIDGES FROM CONSTRUCTION-RELATED EROSION RUNOFF.
- CARTRIDGE INSTALLATION, BY IMBRIUM, SHALL OCCUR ONLY AFTER SITE HAS BEEN STABILIZED AND THE JELLYFISH UNIT IS CLEAN AND FREE OF DEBRIS. CONTACT IMBRIUM TO COORDINATE CARTRIDGE INSTALLATION WITH SITE STABILIZATION.

STANDARD OFFLINE JELLYFISH RECOMMENDED PIPE DIAMETERS			
MODEL DIAMETER (m)	MINIMUM ANGLE INLET/OUTLET PIPES	MINIMUM INLET PIPE DIAMETER (mm)	MINIMUM OUTLET PIPE DIAMETER (mm)
1.2	62	150	200
1.8	69	200	250
2.4	52	250	300
3.0	48	300	450
3.6	40	300	450

CONTACT IMBRIUM SYSTEMS FOR ALTERNATE PIPE DIAMETERS

FOR SITE SPECIFIC DRAWINGS PLEASE CONTACT YOUR LOCAL JELLYFISH FILTER REPRESENTATIVE. SITE SPECIFIC DRAWINGS ARE BASED ON THE BEST AVAILABLE INFORMATION AT THE TIME. SOME FIELD REVISIONS TO THE SYSTEM LOCATION OR CONNECTION PIPING MAY BE NECESSARY BASED ON AVAILABLE SPACE OR SITE CONFIGURATION REVISIONS. ELEVATIONS SHOULD BE MAINTAINED EXCEPT WHERE NOTED ON BYPASS STRUCTURE.

DRAWING NOT TO BE USED FOR CONSTRUCTION

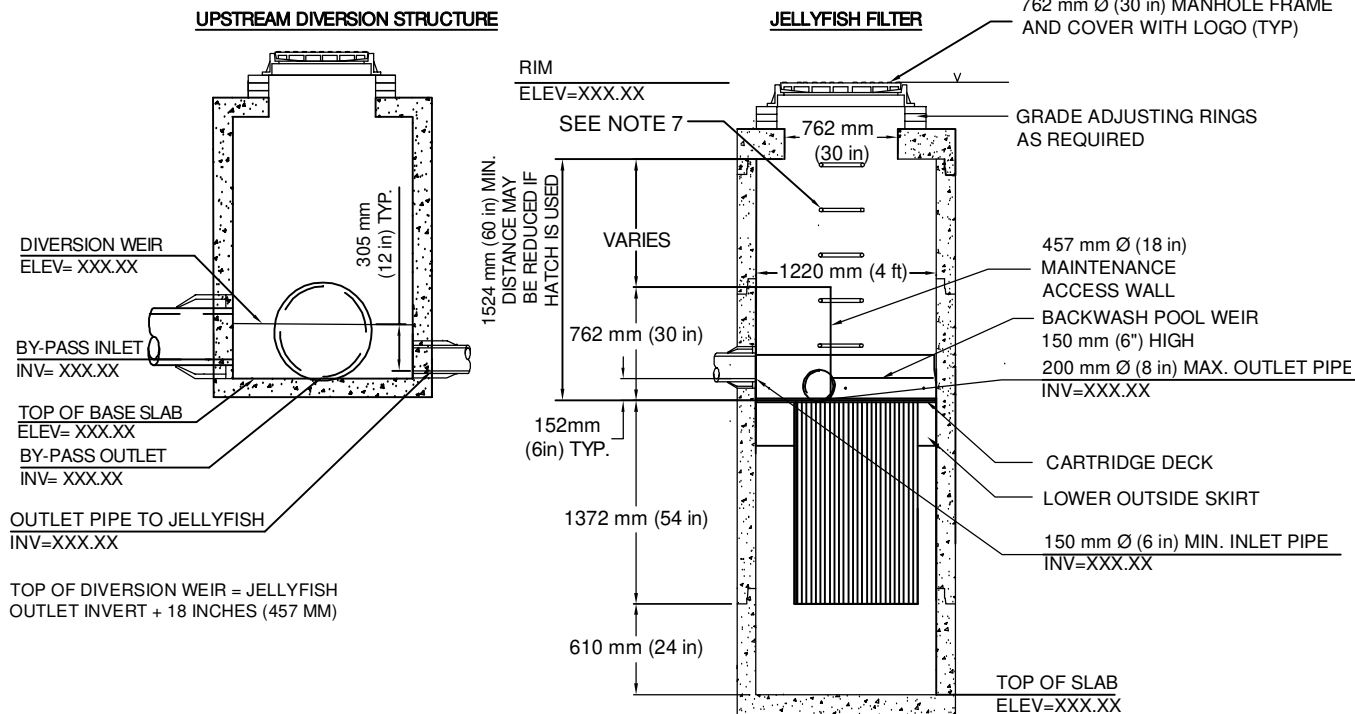
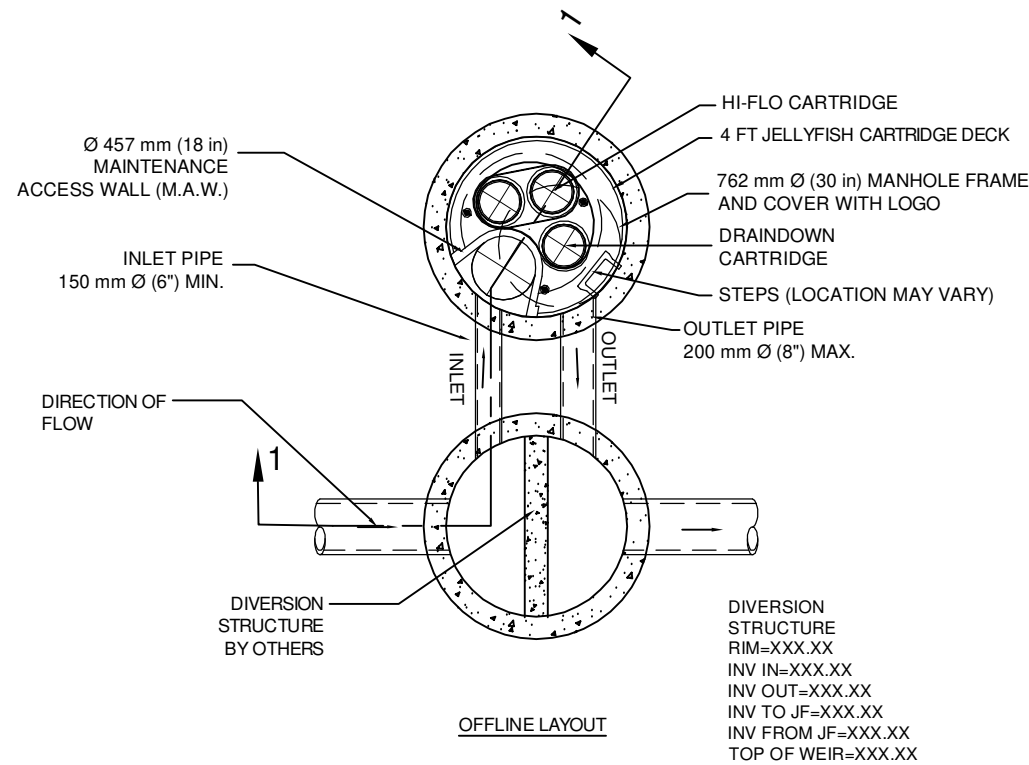

CROSS SECTION 1-1

JELLYFISH DESIGN NOTES

JELLYFISH TREATMENT CAPACITY IS A FUNCTION OF THE CARTRIDGE SELECTION AND THE NUMBER OF CARTRIDGES. THE STANDARD MANHOLE STYLE IS SHOWN. Ø1220 mm (48") MANHOLE JELLYFISH PEAK TREATMENT CAPACITY IS 12.7 L/s (0.54 CFS). TREATMENT FLOW RATE IS BASED ON 457 mm (18") OF HEAD PRESSURE.

CARTRIDGE SELECTION	CARTRIDGE DEPTH	CARTRIDGE INVERT TO STRUCTURE BASE SLAB	OUTLET INVERT TO STRUCTURE BASE SLAB	FLOW RATE HIGH-FLO / DRAINDOWN (L/s) (per cart)	SEDIMENT CAPACITY HIGH-FLO / DRAINDOWN (kg) (per cart)	MAX. CARTRIDGE HIGH-FLO/DRAINDOWN	MAX. SEDIMENT CAPACITY (kg)	MAX. TREATMENT (L/s)
54"	40"	90"	76"	5.09 / 2.55	42 / 21	142	105	12.7
27"	63"	63"	51"	2.55 / 1.27	28 / 14	70	6.2	6.2
15"	15"	15"	15"	1.41 / 0.71	16 / 8	40	3.4	3.4

SITE SPECIFIC DATA REQUIREMENTS					
JELLYFISH MODEL	*				
STRUCTURE ID	*				
WATER QUALITY FLOW RATE (L/s)	*				
PEAK FLOW RATE (L/s)	*				
RETURN PERIOD OF PEAK FLOW (yrs)	*				
# OF CARTRIDGES REQUIRED (HF / DD)	*				
CARTRIDGE SIZE (inches)	*				
PIPE DATA:	I.E.	MAT'L	DIA	SLOPE %	HGL
INLET #1	*	*	*	*	*
INLET #2	*	*	*	*	*
OUTLET	*	*	*	*	*

* PER ENGINEER OF RECORD

JF4 STANDARD
Scale = 1:50

www.imbrium.com

info@imbrium.com

www.imbrium.com

DATE: #####

DESIGNED: BSF DRAWN: BSF

CHECKED: BSF APPROVED: SP

PROJECT #: ##### PROJECT NAME: #####

SHEET: 1 OF 2

The design and information shown on this drawing is provided as a service to the project owner, engineer or contractor. It is not to be used for any other purpose without the prior written consent of Imbrium. Failure to comply with the terms of this drawing may result in Imbrium disclaiming any liability or responsibility for such use.

If discrepancies between the supplied information upon which this drawing is based and the actual conditions are discovered, the user is responsible for obtaining the necessary information and for making any adjustments to the design. Imbrium accepts no responsibility for any errors or omissions in the design or for any consequences that may result from the use of this drawing.

JELLYFISH® FILTER - SPECIFICATIONS

GENERAL

- A. **WORK INCLUDED:** SPECIFIES REQUIREMENTS FOR CONSTRUCTION AND PERFORMANCE OF AN UNDERGROUND STORMWATER QUALITY, MEMBRANE FILTRATION, AND TREATMENT DEVICE THAT REMOVES POLLUTANTS FROM STORMWATER RUNOFF THROUGH THE UNIT OPERATIONS OF SEDIMENTATION, FLOATATION, AND MEMBRANE FILTRATION.
- B. **REFERENCE STANDARDS:**
 ASTM C 891: SPECIFICATION FOR INSTALLATION OF UNDERGROUND PRECAST CONCRETE UTILITY STRUCTURES
 ASTM C 478: SPECIFICATION FOR PRECAST REINFORCED CONCRETE MANHOLE SECTIONS
 ASTM C 990: SPECIFICATION FOR JOINTS FOR CONCRETE MANHOLES USING PREFORMED FLEXIBLE JOINT SEALANTS
 ASTM D 4101: SPECIFICATION FOR COPOLYMER STEPS CONSTRUCTION
- C. **SHOP DRAWINGS:** SHOP DRAWINGS FOR THE STRUCTURE AND PERFORMANCE ARE TO BE SUBMITTED WITH EACH ORDER TO THE CONTRACTOR. CONTRACTOR SHALL FORWARD SHOP DRAWING SUBMITTAL TO THE CONSULTING ENGINEER FOR APPROVAL. SHOP DRAWINGS ARE TO DETAIL THE STRUCTURE PRECAST CONCRETE AND CALL OUT OR NOTE THE FIBERGLASS (FRP) INTERNALS/COMPONENTS.
- D. **PRODUCT SUBSTITUTIONS:** NO PRODUCT SUBSTITUTIONS SHALL BE ACCEPTED UNLESS SUBMITTED 10 DAYS PRIOR TO PROJECT BID DATE, OR AS DIRECTED BY THE ENGINEER OF RECORD. SUBMISSIONS FOR SUBSTITUTIONS REQUIRE REVIEW AND APPROVAL BY THE ENGINEER OF RECORD, FOR HYDRAULIC PERFORMANCE, IMPACT TO PROJECT DESIGNS, EQUIVALENT TREATMENT PERFORMANCE, AND ANY REQUIRED PROJECT PLAN AND REPORT (HYDROLOGY/HYDRAULIC, WATER QUALITY, STORMWATER POLLUTION) MODIFICATIONS THAT WOULD BE REQUIRED BY THE APPROVING JURISDICTIONS/AGENCIES. CONTRACTOR TO COORDINATE WITH THE ENGINEER OF RECORD ANY APPLICABLE MODIFICATIONS TO THE PROJECT ESTIMATES OF COST, BONDING AMOUNT DETERMINATIONS, PLAN CHECK FEES FOR CHANGES TO APPROVED DOCUMENTS, AND/OR ANY OTHER REGULATORY REQUIREMENTS RESULTING FROM THE PRODUCT SUBSTITUTION.
- E. **HANDLING AND STORAGE:** PREVENT DAMAGE TO MATERIALS DURING STORAGE AND HANDLING.

PRODUCTS

- A. THE DEVICE SHALL BE A CYLINDRICAL OR RECTANGULAR, ALL CONCRETE STRUCTURE (INCLUDING RISERS), CONSTRUCTED FROM PRECAST CONCRETE RISER AND SLAB COMPONENTS OR MONOLITHIC PRECAST STRUCTURE(S), INSTALLED TO CONFORM TO ASTM C 891 AND TO ANY REQUIRED STATE HIGHWAY, MUNICIPAL OR LOCAL SPECIFICATIONS; WHICHEVER IS MORE STRINGENT. THE DEVICE SHALL BE WATERTIGHT.
- B. THE CYLINDRICAL CONCRETE DEVICE SHALL INCLUDE A FIBERGLASS CARTRIDGE DECK INSERT. THE RECTANGULAR CONCRETE DEVICE SHALL INCLUDE A COATED ALUMINUM INSERT. IN EITHER INSTANCE, THE INSERT SHALL BE BOLTED AND SEALED WATERTIGHT INSIDE THE PRECAST CONCRETE CHAMBER. THE INSERT SHALL SERVE AS: (A) A HORIZONTAL DIVIDER BETWEEN THE LOWER TREATMENT ZONE AND THE UPPER TREATED EFFLUENT ZONE; (B) A DECK FOR ATTACHMENT OF FILTER CARTRIDGES SUCH THAT THE MEMBRANE FILTER ELEMENTS OF EACH CARTRIDGE EXTEND INTO THE LOWER TREATMENT ZONE; (C) A PLATFORM FOR MAINTENANCE WORKERS TO SERVICE THE FILTER CARTRIDGES (MAXIMUM MANNED WEIGHT = 450 POUNDS); (D) A CONDUIT FOR CONVEYANCE OF TREATED WATER TO THE EFFLUENT PIPE.
- C. MEMBRANE FILTER CARTRIDGES SHALL BE COMPRISED OF REUSABLE CYLINDRICAL MEMBRANE FILTER ELEMENTS CONNECTED TO A PERFORATED HEAD PLATE. THE NUMBER OF MEMBRANE FILTER ELEMENTS PER CARTRIDGE SHALL BE A MINIMUM OF ELEVEN 2.75-INCH (70-MM) OR GREATER DIAMETER ELEMENTS. THE LENGTH OF EACH FILTER ELEMENT SHALL BE A MINIMUM 15 INCHES (381 MM). EACH CARTRIDGE SHALL BE FITTED INTO THE CARTRIDGE DECK BY INSERTION INTO A CARTRIDGE RECEPTACLE THAT IS PERMANENTLY MOUNTED INTO THE CARTRIDGE DECK. EACH CARTRIDGE SHALL BE SECURED BY A CARTRIDGE LID THAT IS THREADED ONTO THE RECEPTACLE, OR SIMILAR MECHANISM TO SECURE THE CARTRIDGE INTO THE DECK. THE MAXIMUM TREATMENT FLOW RATE OF A FILTER CARTRIDGE SHALL BE CONTROLLED BY AN ORIFICE IN THE CARTRIDGE LID, OR ON THE INDIVIDUAL CARTRIDGE ITSELF, AND BASED ON A DESIGN FLUX RATE (SURFACE LOADING RATE) DETERMINED BY THE MAXIMUM TREATMENT FLOW RATE PER UNIT OF FILTRATION MEMBRANE SURFACE AREA. THE MAXIMUM FLUX RATE SHALL BE 0.21 GPM/FT2 (0.142 LPS/M2). EACH MEMBRANE FILTER CARTRIDGE SHALL ALLOW FOR MANUAL INSTALLATION AND REMOVAL.
- D. ALL FILTER CARTRIDGES AND MEMBRANES SHALL BE REUSABLE AND ALLOW FOR THE USE OF FILTRATION MEMBRANE RINSING PROCEDURES TO RESTORE FLOW CAPACITY AND SEDIMENT CAPACITY; EXTENDING CARTRIDGE SERVICE LIFE.
- E. ACCESS SHALL HAVE A MINIMUM CLEAR HEIGHT OF 60" OVER ALL OF THE FILTER CARTRIDGES, OR BE ACCESSIBLE BY A HATCH OR OTHER MECHANISM THAT PROVIDES MINIMUM 60" VERTICAL CLEAR SPACE OVER ALL OF THE FILTER CARTRIDGES. FILTER CARTRIDGES SHALL BE ABLE TO BE LIFTED STRAIGHT VERTICALLY OUT OF THE RECEPTACLES AND DECK FOR THE ENTIRE LENGTH OF THE CARTRIDGE.
- F. THE DEVICE SHALL INCLUDE A MINIMUM 24 INCHES (610 MM) OF SUMP BELOW THE BOTTOM OF THE CARTRIDGES FOR SEDIMENT ACCUMULATION, UNLESS OTHERWISE SPECIFIED BY THE DESIGN ENGINEER. DEPTHS LESS THAN 24" MAY HAVE AN IMPACT ON THE TOTAL PERFORMANCE AND/OR LONGEVITY BETWEEN CARTRIDGE MAINTENANCE/REPLACEMENT OF THE DEVICE.
- G. ALL PRECAST CONCRETE COMPONENTS SHALL BE MANUFACTURED TO A MINIMUM LIVE LOAD OF HS-20 TRUCK LOADING OR GREATER BASED ON LOCAL REGULATORY SPECIFICATIONS, UNLESS OTHERWISE MODIFIED OR SPECIFIED BY THE DESIGN ENGINEER, AND SHALL BE WATERTIGHT.
- H. GASKETS AND/OR SEALANTS TO PROVIDE WATER TIGHT SEAL BETWEEN CONCRETE JOINTS. JOINTS SHALL BE SEALED WITH PREFORMED JOINT SEALING COMPOUND CONFORMING TO ASTM C 990.
- I. FRAME AND COVERS MUST BE MANUFACTURED FROM CAST-IRON OR OTHER COMPOSITE MATERIAL TESTED TO WITHSTAND H-20 OR GREATER DESIGN LOADS, AND AS APPROVED BY THE LOCAL REGULATORY BODY. FRAMES AND COVERS MUST BE EMBOSSED WITH THE NAME OF THE DEVICE MANUFACTURER OR THE DEVICE BRAND NAME.
- J. DOOR AND HATCHES, IF PROVIDED SHALL MEET DESIGNATED LOADING REQUIREMENTS OR AT A MINIMUM FOR INCIDENTAL VEHICULAR TRAFFIC.
- K. ALL CONCRETE COMPONENTS SHALL BE MANUFACTURED ACCORDING TO LOCAL SPECIFICATIONS AND SHALL MEET THE REQUIREMENTS OF ASTM C 478.
- L. THE FIBERGLASS PORTION OF THE FILTER DEVICE SHALL BE CONSTRUCTED IN ACCORDANCE WITH THE FOLLOWING STANDARD: ASTM D-4097: CONTACT MOLDED GLASS FIBER REINFORCED CHEMICAL RESISTANT TANKS.
- M. STEPS SHALL BE CONSTRUCTED ACCORDING TO ASTM D4101 OF COPOLYMER POLYPROPYLENE, AND BE DRIVEN INTO PREFORMED OR PRE-DRILLED HOLES AFTER THE CONCRETE HAS CURED, INSTALLED TO CONFORM TO APPLICABLE SECTIONS OF STATE, PROVINCIAL AND MUNICIPAL BUILDING CODES, HIGHWAY, MUNICIPAL OR LOCAL SPECIFICATIONS FOR THE CONSTRUCTION OF SUCH DEVICES.
- N. ALL PRECAST CONCRETE SECTIONS SHALL BE INSPECTED TO ENSURE THAT DIMENSIONS, APPEARANCE AND QUALITY OF THE PRODUCT MEET LOCAL MUNICIPAL SPECIFICATIONS AND ASTM C 478.

PERFORMANCE

- A. THE STORMWATER QUALITY FILTER TREATMENT DEVICE SHALL FUNCTION TO REMOVE POLLUTANTS BY THE FOLLOWING UNIT TREATMENT PROCESSES; SEDIMENTATION, FLOATATION, AND MEMBRANE FILTRATION.
- B. THE STORMWATER QUALITY FILTER TREATMENT DEVICE SHALL REMOVE OIL, DEBRIS, TRASH, COARSE AND FINE PARTICULATES, PARTICULATE-BOUND POLLUTANTS, METALS AND NUTRIENTS FROM STORMWATER DURING RUNOFF EVENTS.
- C. THE STORMWATER QUALITY FILTER TREATMENT DEVICE SHALL TYPICALLY UTILIZE AN EXTERNAL BYPASS TO DIVERT EXCESSIVE FLOWS. INTERNAL BYPASS SYSTEMS SHALL BE EQUIPPED WITH A FLOATABLES BAFFLE, AND MUST PASS WATER OVER THE CARTRIDGE DECK, AND AVOID PASSAGE THROUGH THE SUMP AND/OR CARTRIDGE FILTRATION ZONE.
- D. THE STORMWATER QUALITY FILTER TREATMENT DEVICE SHALL TREAT 100% OF THE REQUIRED WATER QUALITY TREATMENT FLOW BASED ON A MAXIMUM TREATMENT FLUX RATE (SURFACE LOADING RATE) ACROSS THE MEMBRANE FILTER CARTRIDGES NOT TO EXCEED 0.21 GPM/FT2 (0.142 LPS/M2).
- E. AT A MINIMUM, THE STORMWATER QUALITY FILTER DEVICE SHALL HAVE BEEN FIELD TESTED AND VERIFIED WITH A MINIMUM 25 QUALIFYING STORM EVENTS AND FIELD MONITORING CONDUCTED ACCORDING TO THE TARP TIER II OR TAPE FIELD TEST PROTOCOL, AND HAVE RECEIVED NJCAT VERIFICATION.
- F. THE STORMWATER QUALITY FILTER TREATMENT DEVICE SHALL HAVE DEMONSTRATED A MINIMUM MEDIAN TSS REMOVAL EFFICIENCY OF 85% AND A MINIMUM MEDIAN SSC REMOVAL EFFICIENCY OF 95%.
- G. THE STORMWATER QUALITY FILTER TREATMENT DEVICE SHALL HAVE DEMONSTRATED THE ABILITY TO CAPTURE FINE PARTICLES AS INDICATED BY A MINIMUM MEDIAN REMOVAL EFFICIENCY OF 75% FOR THE PARTICLE FRACTION LESS THAN 25 MICRONS, AN EFFLUENT D50 OF 15 MICRONS OR LOWER FOR ALL MONITORED STORM EVENTS, AND AN EFFLUENT TURBIDITY OF 15 NTUS OR LOWER.
- H. THE STORMWATER QUALITY FILTER TREATMENT DEVICE SHALL HAVE DEMONSTRATED A MINIMUM MEDIAN TOTAL PHOSPHORUS REMOVAL OF 55%, AND A MINIMUM MEDIAN TOTAL NITROGEN REMOVAL OF 50%.
- I. THE STORMWATER QUALITY FILTER TREATMENT DEVICE SHALL HAVE DEMONSTRATED A MINIMUM MEDIAN TOTAL ZINC REMOVAL OF 50%, AND A MINIMUM MEDIAN TOTAL COPPER REMOVAL OF 75%.

INSPECTION AND MAINTENANCE

- A. DURABILITY OF MEMBRANES ARE SUBJECT TO GOOD HANDLING PRACTICES DURING INSPECTION AND MAINTENANCE (REMOVAL, RINSING, AND REINSERTION) EVENTS, AND SITE SPECIFIC CONDITIONS THAT MAY HAVE HEAVIER OR LIGHTER LOADING ONTO THE CARTRIDGES, AND POLLUTANT VARIABILITY THAT MAY IMPACT THE MEMBRANE STRUCTURAL INTEGRITY. MEMBRANE MAINTENANCE AND REPLACEMENT SHALL BE IN ACCORDANCE WITH MANUFACTURER'S RECOMMENDATIONS.
- B. INSPECTION WHICH INCLUDES TRASH AND FLOATABLES COLLECTION, SEDIMENT DEPTH DETERMINATION, AND VISIBLE DETERMINATION OF BACKWASH POOL DEPTH SHALL BE EASILY CONDUCTED FROM GRADE (OUTSIDE THE STRUCTURE).
- C. MANUAL RINSING OF THE REUSABLE FILTER CARTRIDGES SHALL PROMOTE RESTORATION OF THE FLOW CAPACITY AND SEDIMENT CAPACITY OF THE FILTER CARTRIDGES, EXTENDING CARTRIDGE SERVICE LIFE.
- D. SEDIMENT REMOVAL FROM THE FILTER TREATMENT DEVICE SHALL BE ABLE TO BE CONDUCTED USING A STANDARD MAINTENANCE TRUCK AND VACUUM APPARATUS, AND A MINIMUM ONE POINT OF ENTRY TO THE SUMP THAT IS UNOBSTRUCTED BY FILTER CARTRIDGES.
- E. MAINTENANCE ACCESS SHALL HAVE A MINIMUM CLEAR HEIGHT OF 60" OVER ALL OF THE FILTER CARTRIDGES, OR BE ACCESSIBLE BY A HATCH OR OTHER MECHANISM THAT PROVIDES MINIMUM 60" VERTICAL CLEAR SPACE OVER ALL OF THE FILTER CARTRIDGES. FILTER CARTRIDGES SHALL BE ABLE TO BE LIFTED STRAIGHT VERTICALLY OUT OF THE RECEPTACLES AND DECK FOR THE ENTIRE LENGTH OF THE CARTRIDGE.
- F. FILTER CARTRIDGES SHALL BE ABLE TO BE MAINTAINED WITHOUT THE USE OF ADDITIONAL LIFTING EQUIPMENT.

EXECUTION

- A. THE INSTALLATION OF A WATERTIGHT PRECAST CONCRETE DEVICE SHOULD CONFORM TO ASTM C 891 AND TO ANY STATE HIGHWAY, MUNICIPAL OR LOCAL SPECIFICATIONS FOR THE CONSTRUCTION OF MANHOLES, WHICHEVER IS MORE STRINGENT. SELECTED SECTIONS OF A GENERAL SPECIFICATION THAT ARE APPLICABLE ARE SUMMARIZED BELOW.
- B. THE WATERTIGHT PRECAST CONCRETE DEVICE IS INSTALLED IN SECTIONS IN THE FOLLOWING SEQUENCE:
- AGGREGATE BASE
 - BASE SLAB
 - TREATMENT CHAMBER AND CARTRIDGE DECK RISER SECTION(S)
 - BYPASS SECTION
 - CONNECT INLET AND OUTLET PIPES
 - CONCRETE RISER SECTION(S) AND/OR TRANSITION SLAB (IF REQUIRED)
 - MAINTENANCE RISER SECTION(S) (IF REQUIRED)
 - FRAME AND ACCESS COVER
- C. INLET AND OUTLET PIPES SHOULD BE SECURELY SET INTO THE DEVICE USING APPROVED PIPE SEALS (FLEXIBLE BOOT CONNECTIONS, WHERE APPLICABLE) SO THAT THE STRUCTURE IS WATERTIGHT, AND SUCH THAT ANY PIPE INTRUSION INTO THE DEVICE DOES NOT IMPACT THE DEVICE FUNCTIONALITY.
- D. ADJUSTMENT UNITS (E.G. GRADE RINGS) SHOULD BE INSTALLED TO SET THE FRAME AND COVER AT THE REQUIRED ELEVATION. THE ADJUSTMENT UNITS SHOULD BE LAID IN A FULL BED OF MORTAR WITH SUCCESSIVE UNITS BEING JOINED USING SEALANT RECOMMENDED BY THE MANUFACTURER. FRAMES FOR THE COVER SHOULD BE SET IN A FULL BED OF MORTAR AT THE ELEVATION SPECIFIED.
- E. IN SOME INSTANCES THE MAINTENANCE ACCESS WALL, IF PROVIDED, SHALL REQUIRE AN EXTENSION ATTACHMENT AND SEALING TO THE PRECAST WALL AND CARTRIDGE DECK AT THE JOB SITE, RATHER THAN AT THE PRECAST FACILITY. IN THIS INSTANCE, INSTALLATION OF THESE COMPONENTS SHALL BE PERFORMED ACCORDING TO INSTRUCTIONS PROVIDED BY THE MANUFACTURER.
- F. FILTER CARTRIDGES SHALL BE INSTALLED IN THE CARTRIDGE DECK AFTER THE CONSTRUCTION SITE IS FULLY STABILIZED AND IN ACCORDANCE WITH THE MANUFACTURER'S GUIDELINES AND RECOMMENDATIONS. CONTRACTOR TO CONTACT THE MANUFACTURER TO SCHEDULE CARTRIDGE DELIVERY AND REVIEW PROCEDURES/REQUIREMENTS TO BE COMPLETED TO THE DEVICE PRIOR TO INSTALLATION OF THE CARTRIDGES AND ACTIVATION OF THE SYSTEM.
- G. MANUFACTURER SHALL COORDINATE DELIVERY OF FILTER CARTRIDGES AND OTHER INTERNAL COMPONENTS WITH CONTRACTOR. FILTER CARTRIDGES SHALL BE DELIVERED AND INSTALLED COMPLETE AFTER SITE IS STABILIZED AND UNIT IS READY TO ACCEPT CARTRIDGES. UNIT IS READY TO ACCEPT CARTRIDGES AFTER IS HAS BEEN CLEANED OUT AND ANY STANDING WATER, DEBRIS, AND OTHER MATERIALS HAVE BEEN REMOVED. CONTRACTOR SHALL TAKE APPROPRIATE ACTION TO PROTECT THE FILTER CARTRIDGE RECEPTACLES AND FILTER CARTRIDGES FROM DAMAGE DURING CONSTRUCTION, AND IN ACCORDANCE WITH THE MANUFACTURER'S RECOMMENDATIONS AND GUIDANCE. FOR SYSTEMS WITH CARTRIDGES INSTALLED PRIOR TO FULL SITE STABILIZATION AND PRIOR TO SYSTEM ACTIVATION, THE CONTRACTOR CAN PLUG INLET AND OUTLET PIPES TO PREVENT STORMWATER AND OTHER INFLENT FROM ENTERING THE DEVICE. PLUGS MUST BE REMOVED DURING THE ACTIVATION PROCESS.
- H. THE MANUFACTURER SHALL PROVIDE AN OWNER'S MANUAL UPON REQUEST.
- I. AFTER CONSTRUCTION AND INSTALLATION, AND DURING OPERATION, THE DEVICE SHALL BE INSPECTED AND CLEANED AS NECESSARY BASED ON THE MANUFACTURER'S RECOMMENDED INSPECTION AND MAINTENANCE GUIDELINES AND THE LOCAL REGULATORY AGENCY/BODY.
- J. WHEN REPLACEMENT MEMBRANE FILTER ELEMENTS AND/OR OTHER PARTS ARE REQUIRED, ONLY MEMBRANE FILTER ELEMENTS AND PARTS APPROVED BY THE MANUFACTURER FOR USE WITH THE STORMWATER QUALITY FILTER DEVICE SHALL BE INSTALLED.

END OF SECTION

The design and information shown on this drawing is provided as a service to the project owner, engineer or contractor. It is not to be construed as a contract. Neither the drawings, nor any part thereof, may be used, reproduced or modified in any manner without the prior written consent of Imbrium. Failure to comply with the terms and conditions of this drawing is the sole responsibility of the user. Imbrium does not assume any liability or responsibility for such use. If discrepancies between the supplied information upon which this drawing is based and the information shown are encountered in the work program, these discrepancies must be reported to Imbrium immediately for the attention of the design. Imbrium accepts no liability for errors or omissions in the design or drawings or for any information supplied by others.

#	#	#	#	BSF	BY
#	#	#	#	INITIAL RELEASE	REVISION DESCRIPTION
#	#	#	#	10/01/2014	DATE
#	#	#	#	0	MARK

JELLYFISH FILTER SPECIFICATIONS



JF4 STANDARD
Scale = 1.50

www.imbriumglobals.com
info@imbriumglobals.com



407 FAIRVIEW DRIVE, WHITBY, ON L1N 3A9
 TEL: 905-889-9671 CA: (416) 990-9900 INTL: +1 416 990-9900
Jellyfish Filter
 THIS PRODUCT MAY BE PROTECTED BY ONE OR MORE OF THE FOLLOWING: PATENT, TRADE SECRET, DESIGN PATENT, COPYRIGHT, TRADE MARK, OR OTHER INTELLECTUAL PROPERTY RIGHTS.

DATE: #####

DESIGNED:	DRAWN:
CHECKED: BSF	APPROVED: SP
PROJECT #: #####	PROJECT NAME: #####
SHEET: 2	OF 2

APPENDIX C
Water Supply Calculations



Water Supply Calculations

LRL File No. 230202
 Date 2024-06-12
 Prepared by M. Longtin
 Checked by M. Basnet

Water Demand based on the City of Ottawa Design Guidelines-Water Distribution, 2010

Institutional / Commercial / Industrial Demand			
Property Type	Unit Rate	Units	Demand (L/d)
Building 3 - Light Industrial	35000 L/ha/d	0.246 ha	8613.4
Building 2 - Commercial other	28000 L/ha/d	0.242 ha	6769.1
Building 1 - Commercial other	28000 L/ha/d	0.074 ha	2073.4

Average Day Demand 17,456 L/d 0.202 L/s

Maximum Day Factor 1.5 (Design Guidelines-Water Distribution Table 4.2)
Maximum Daily Demand 26,184 L/d 0.303 L/s

Peak Hour Factor 1.8 (Design Guidelines-Water Distribution Table 4.2)
Maximum Hour Demand 47,131 L/d 0.545 L/s

Water Service Pipe Sizing

$$Q = VA$$

Where: V = velocity

A = area of pipe

Q = flow rate

Assuming a maximum velocity of 1.8m/s, the diameter of pipe is calculated as:

$$\begin{aligned} \text{Minimum pipe diameter (d)} &= (4Q/\pi V)^{1/2} \\ &= 0.020 \text{ m} \\ &= 20 \text{ mm} \end{aligned}$$

$$\text{Proposed pipe diameter (d)} = 100 \text{ mm}$$



Fire Flow Calculations

LRL File No. 230202
 Date June 12, 2024
 Method Fire Underwriters Survey (FUS)
 Prepared by M. Longtin
 Checked by M. Basnet

Step	Task	Term	Options	Multiplier	Choose:	Value	Unit	Fire Flow	
Structural Framing Material									
1	Choose frame used for building	Coefficient C related to the type of construction	Wood Frame	1.5	Non-combustible construction	0.8			
			Ordinary Construction	1.0					
			Non-combustible construction	0.8					
			Fire resistive construction <2 hrs	0.7					
			Fire resistive construction >2 hrs	0.6					
Floor Space Area (A)									
2			Building Footprint			1,349	m ²		
3	Obtain fire flow before reductions	Required fire flow (rounded to nearest 1,000 L/min)	$Fire\ Flow = 220 \times C \times A^{0.5}$					L/min	7,000
Reductions or surcharge due to factors affecting burning									
4	Choose combustibility of contents	Occupancy hazard reduction or surcharge	Non-combustible	-25%	Combustible	0%	L/min	7,000	
			Limited combustible	-15%					
			Combustible	0%					
			Free burning	15%					
			Rapid burning	25%					
5	Choose reduction for sprinklers	Sprinkler reduction	Full automatic sprinklers	-30%	False	0%	L/min	7,000	
			Water supply is standard for both the system and fire department hose lines	-10%	False	0%			
			Fully supervised system	-10%	False	0%			
6	Choose separation	Exposure distance between units	North side	20.1 to 30m	10%	L/min	8,750		
			South side	10.1 to 20m	15%				
			East side	>30m	0%				
			West side	>30m	0%				
Net required fire flow									
7	Obtain fire flow, duration, and volume					Minimum required fire flow rate (rounded to nearest 1000)	L/min	9,000	
						Minimum required fire flow rate	L/s	150.0	
						Required duration of fire flow	hr	2	

Existing Fire Hydrants 1280 Trim Road, Ottawa, ON.

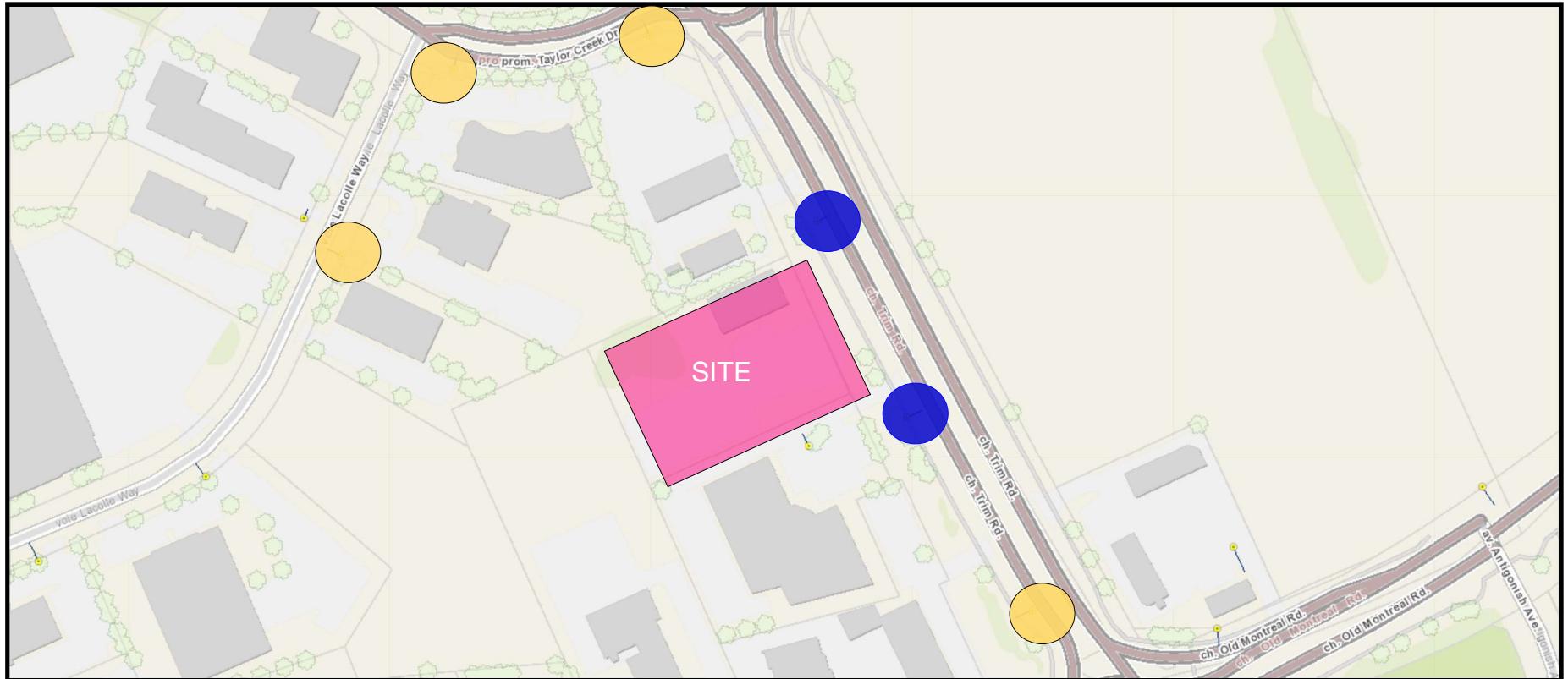



Table 18.5.4.3 Maximum fire flow hydrant capacity

Distance to buildings ^a		Maximum capacity ^b	
(ft)	(m)	(gpm)	(L/min)
≤ 250	≤ 76	1500	5678
> 250 and ≤ 500	> 76 and ≤ 152	1000	3785
> 500 and ≤ 1000	> 152 and ≤ 305	750	2839

LEGEND

-  Hydrants within 150m
-  Hydrants within 300m

Boundary Conditions R1 - 1280 Trim Road

Provided Information

Scenario	Demand	
	L/min	L/s
Average Daily Demand	12	0.20
Maximum Daily Demand	18	0.30
Peak Hour	33	0.55
Fire Flow Demand #1	9,000	150.00

Location

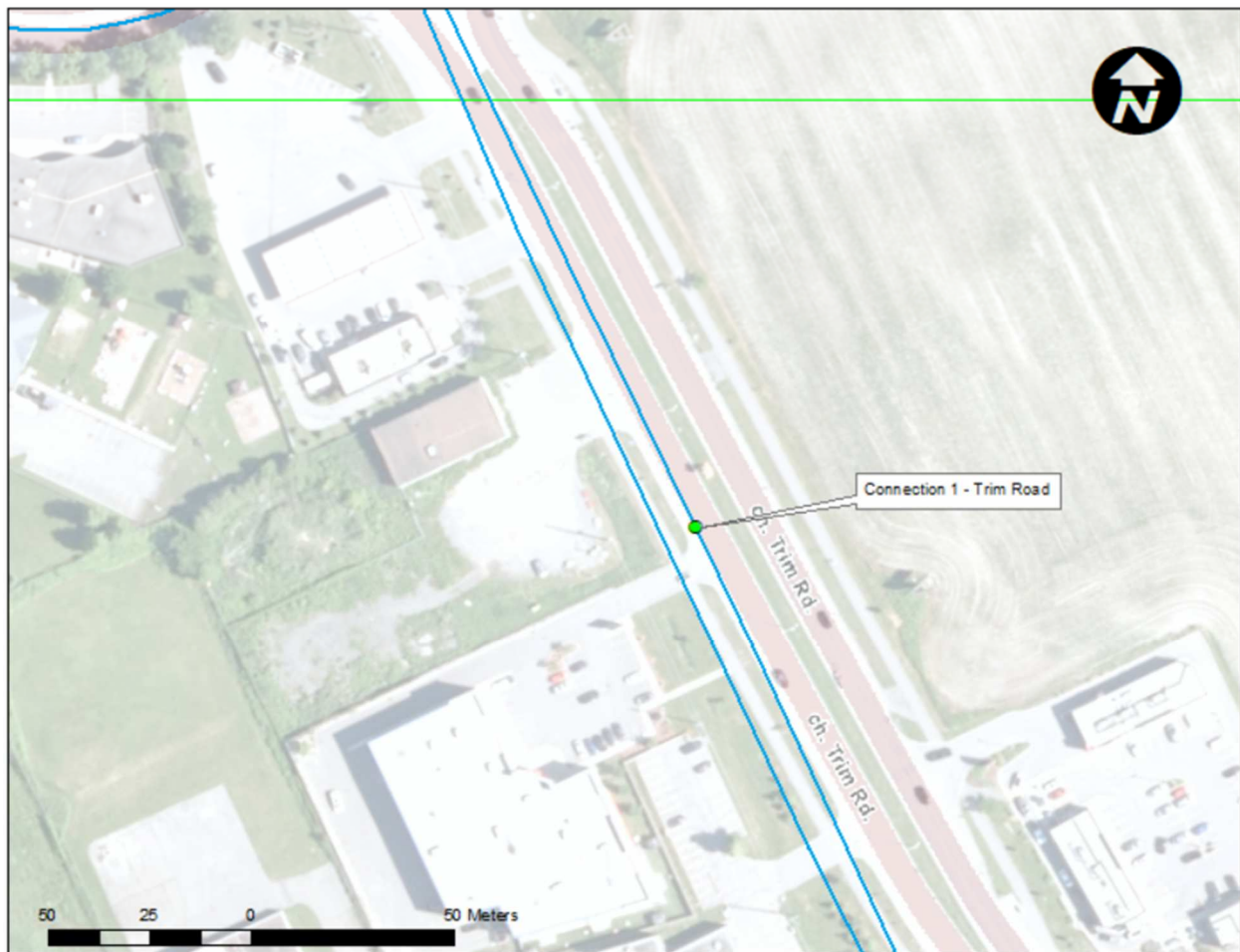

Results

Connection 1 – Trim Road

Demand Scenario	Head (m)	Pressure¹ (psi)
Maximum HGL	114.1	74.0
Peak Hour	109.4	67.4
Max Day plus Fire Flow	106.0	62.6

¹ Ground Elevation = 62.0 m

Notes

1. Any connection to a watermain 400 mm or larger should be approved by Drinking Water Service (now Water Distribution Branch – Water Linear and Customer Service) as per the Water Design Guidelines Section 2.4.

Disclaimer

The boundary condition information is based on current operation of the city water distribution system. The computer model simulation is based on the best information available at the time. The operation of the water distribution system can change on a regular basis, resulting in a variation in boundary conditions. The physical properties of watermains deteriorate over time, as such must be assumed in the absence of actual field test data. The variation in physical watermain properties can therefore alter the results of the computer model simulation. Fire Flow analysis is a reflection of available flow in the watermain; there may be additional restrictions that occur between the watermain and the hydrant that the model cannot take into account.

Mohan Basnet

From: Charie, Kelsey <kelsey.charie@ottawa.ca>
Sent: June 20, 2024 3:00 PM
To: Maxime Longtin; Mohan Basnet
Cc: Unrau, Derek; Ramirez, Lucy
Subject: RE: LRL230202_1280 Trim Rd_Boundary Conditions Request

Hello again,

I had wanted to ensure that there would be no issues down the road with this application and the note within the results had me concerned.

1. Any connection to a watermain 400 mm or larger should be approved by Drinking Water Service (now Water Distribution Branch – Water Linear and Customer Service) as per the Water Design Guidelines Section 2.4.

After following up directly, the Water Distribution Branch was able to provide the following response:

The connection to the 406mm watermain is acceptable. My only comment is the connection to the 406mm watermain is to be a TEE connection not a TVS connection. TVS connections are only accepted in extenuating circumstances. (i.e. a very large isolation of a watermain affecting and large number of customers).

Hope that helps provide clarification.

Regards,
Kelsey

From: Charie, Kelsey
Sent: June 20, 2024 2:25 PM
To: 'Maxime Longtin' <mlongtin@lrl.ca>; Mohan Basnet <mbasnet@lrl.ca>
Cc: Unrau, Derek <derek.unrau@ottawa.ca>; Ramirez, Lucy <lucy.ramirez@ottawa.ca>
Subject: RE: LRL230202_1280 Trim Rd_Boundary Conditions Request

Hello Maxime,

I received the attached results this afternoon. Please let me know if there is anything else I can assist with.

Kelsey

From: Maxime Longtin <mlongtin@lrl.ca>
Sent: June 20, 2024 11:58 AM
To: Charie, Kelsey <kelsey.charie@ottawa.ca>; Mohan Basnet <mbasnet@lrl.ca>
Cc: Unrau, Derek <derek.unrau@ottawa.ca>; Ramirez, Lucy <lucy.ramirez@ottawa.ca>
Subject: RE: LRL230202_1280 Trim Rd_Boundary Conditions Request

CAUTION: This email originated from an External Sender. Please do not click links or open attachments unless you recognize the source.

ATTENTION : Ce courriel provient d'un expéditeur externe. Ne cliquez sur aucun lien et n'ouvrez pas de pièce jointe, excepté si vous connaissez l'expéditeur.

Good morning,

Following up on these.

Thanks 😊

Maxime Longtin

Civil Engineering Technologist and Team Manager

LRL Engineering | lrl.ca

Cell: (613)915-8043 | m.longtin@lrl.ca



Excited to announce we are now also operating out of our Pembroke Office, located at **1344 Pembroke Street West, Pembroke ON**

From: Charie, Kelsey <kelsey.charie@ottawa.ca>

Sent: Tuesday, June 18, 2024 12:07 PM

To: Mohan Basnet <mbasnet@lrl.ca>

Cc: Unrau, Derek <derek.unrau@ottawa.ca>; Ramirez, Lucy <lucy.ramirez@ottawa.ca>; Maxime Longtin <m.longtin@lrl.ca>

Subject: RE: LRL230202_1280 Trim Rd_Boundary Conditions Request

Thank you,

I checked in with the water distributions group and they said the new boundary conditions are complete and are currently being reviewed. I am hopeful that means we will receive them later today. Will keep everyone updated when I hear from them.

Kelsey

From: Mohan Basnet <mbasnet@lrl.ca>

Sent: June 18, 2024 11:33 AM

To: Charie, Kelsey <kelsey.charie@ottawa.ca>

Cc: Unrau, Derek <derek.unrau@ottawa.ca>; Ramirez, Lucy <lucy.ramirez@ottawa.ca>; Maxime Longtin <m.longtin@lrl.ca>

Subject: RE: LRL230202_1280 Trim Rd_Boundary Conditions Request

CAUTION: This email originated from an External Sender. Please do not click links or open attachments unless you recognize the source.

ATTENTION : Ce courriel provient d'un expéditeur externe. Ne cliquez sur aucun lien et n'ouvrez pas de pièce jointe, excepté si vous connaissez l'expéditeur.

Hi Kelsey,

Please find attached revised servicing plan, that shows revised connection, as well as geoOttawa schematic.

Thank you.

Mohan Basnet, P.Eng., Ph.D.

Civil Engineer

LRL Engineering | lrl.ca

Cell: [\(613\)229-6819](tel:6132296819) | mbasnet@lrl.ca



From: Charie, Kelsey <kelsey.charie@ottawa.ca>

Sent: Tuesday, June 18, 2024 8:19 AM

To: Maxime Longtin <mlongtin@lrl.ca>

Cc: Mohan Basnet <mbasnet@lrl.ca>; Unrau, Derek <derek.unrau@ottawa.ca>; Ramirez, Lucy <lucy.ramirez@ottawa.ca>

Subject: RE: LRL230202_1280 Trim Rd_Boundary Conditions Request

Good morning, I will follow up again today, they may be a bit behind schedule.

Kelsey

From: Maxime Longtin <mlongtin@lrl.ca>

Sent: June 17, 2024 7:54 PM

To: Charie, Kelsey <kelsey.charie@ottawa.ca>

Cc: Mohan Basnet <mbasnet@lrl.ca>; Unrau, Derek <derek.unrau@ottawa.ca>; Ramirez, Lucy <lucy.ramirez@ottawa.ca>

Subject: Re: LRL230202_1280 Trim Rd_Boundary Conditions Request

CAUTION: This email originated from an External Sender. Please do not click links or open attachments unless you recognize the source.

ATTENTION : Ce courriel provient d'un expéditeur externe. Ne cliquez sur aucun lien et n'ouvrez pas de pièce jointe, excepté si vous connaissez l'expéditeur.

Good evening Kelsey,

Thanks for sending this. Although this is not the desired outcome for our Client, we understand.

We'll proceed that way once we receive the revised boundary conditions. Do we know when these will be ready?

Have a good one,

Maxime Longtin

Civil Engineering Technologist and Team Manager

LRL Engineering | lrl.ca

Cell: [\(613\)915-8043](tel:6139158043) | m.longtin@lrl.ca



On Jun 14, 2024, at 12:01 PM, Charie, Kelsey <kelsey.charie@ottawa.ca> wrote:

Hi Maxime,

Please see water distributions response regarding which water main on Trim is permitted to be connected to.

I want to let you know that the closer of the 2 watermains to the site is a feeder main supplying pressure zone 2E. However, this application locates in the pressure zone 1E, similar to other water service connections in the area. Because of this, the applicant is only permitted to connect to the watermain closer to the center line of Trim, which supplies pressure zone 1E.

I understand this may not be the outcome you were looking for, please let me know if you would like to discuss, or if I can assist further.

Kelsey

From: Maxime Longtin <m.longtin@lrl.ca>

Sent: June 13, 2024 8:51 AM

To: Charie, Kelsey <kelsey.charie@ottawa.ca>; Mohan Basnet <mbasnet@lrl.ca>

Cc: Unrau, Derek <derek.unrau@ottawa.ca>

Subject: RE: LRL230202_1280 Trim Rd_Boundary Conditions Request

CAUTION: This email originated from an External Sender. Please do not click links or open attachments unless you recognize the source.

ATTENTION : Ce courriel provient d'un expéditeur externe. Ne cliquez sur aucun lien et n'ouvrez pas de pièce jointe, excepté si vous connaissez l'expéditeur.

Good morning Kelsey,

Thanks for this, see attached revised servicing plan.

We were under the impression that we could connect to the closest one but let us know if this is not the case as this will mean road cuts and lane closures.

Have a good one

Maxime Longtin

Civil Engineering Technologist and Team Manager

LRL Engineering | lrl.ca

Cell: (613)915-8043 | m.longtin@lrl.ca

<image001.png>

Excited to announce we are now also operating out of our Pembroke Office, located at **1344 Pembroke Street West, Pembroke ON**

From: Charie, Kelsey <kelsey.charie@ottawa.ca>

Sent: Thursday, June 13, 2024 8:42 AM

To: Mohan Basnet <mbasnet@lrl.ca>; Maxime Longtin <m.longtin@lrl.ca>

Cc: Unrau, Derek <derek.unrau@ottawa.ca>

Subject: RE: LRL230202_1280 Trim Rd_Boundary Conditions Request

Hi LRL,

I can definitely request revised BCs but I will need a revised servicing plan or at least a revised sketch for the new request that shows the new connection location to the proper water main.

There are 2 water mains within Trim and your servicing plan shows a connection to the closer water main while it appears that our Water Distribution Group would like you to connect to the water main farther from the property line. Here is the picture from the original BCs.

<image002.png>

I can follow up with Water Distribution if the closer one can be connected to, but based on the area, it looks like all the fire hydrants and other water services are connected to the watermain closer to the center line of Trim Road, so it may be that the other watermain may be abandoned in the future.

Hope that helps clarify,

Kelsey Charie

Project Manager

Planning, Development and Building Services Department
Development Review - East Branch
City of Ottawa

From: Mohan Basnet <mbasnet@lrl.ca>
Sent: June 12, 2024 4:38 PM
To: Charie, Kelsey <kelsey.charie@ottawa.ca>
Cc: Maxime Longtin <mlongtin@lrl.ca>
Subject: RE: LRL230202_1280 Trim Rd_Boundary Conditions Request

CAUTION: This email originated from an External Sender. Please do not click links or open attachments unless you recognize the source.

ATTENTION : Ce courriel provient d'un expéditeur externe. Ne cliquez sur aucun lien et n'ouvrez pas de pièce jointe, excepté si vous connaissez l'expéditeur.

Hi Kelsey,

Could you provide the boundary conditions with the following revised design parameters?

Scenario	Demand (L/s)
Avg. Daily	0.20
Max. Day + FUS	0.30 + 150
Peak Hour	0.55

For location of the proposed connection, please see the attached revised draft site plan.

Thank you.

Mohan Basnet, P.Eng., Ph.D.
Civil Engineer
LRL Engineering | lrl.ca
Cell: [\(613\)229-6819](tel:6132296819) | mbasnet@lrl.ca

<image001.png>

From: Maxime Longtin <mlongtin@lrl.ca>
Sent: Tuesday, June 11, 2024 1:30 PM
To: Charie, Kelsey <kelsey.charie@ottawa.ca>
Cc: Mohan Basnet <mbasnet@lrl.ca>
Subject: RE: LRL230202_1280 Trim Rd_Boundary Conditions Request

Hello Kelsey,

Since we talked, the site plan has changed drastically on this site. This is changing the location of our water connection.

APPENDIX D
Sanitary Calculations

LRL Associates Ltd.
Sanitary Design Sheet



LRL File No.: 230202
Project: Proposed Development-Trim Road Development
Location: 1280 Trim Rd, Ottawa, ON
Designed: M.L./M.B.
Checked: M.B.
Date: October 10, 2024
DWG. Reference: C401

Sanitary Design Parameters

Commercial & Institutional Flow = 28000 L/ha/day
 Light Industrial Flow = 35000 L/ha/day
 Heavy Industrial Flow = 55000 L/ha/day
 Maximum Residential Peak Factor = 4.0
 Commercial & Institutional Peak Factor = 1.5

Average Daily Flow = 280 L/p/day
 Industrial Peak Factor = as per Appendix 4-B
 Extraneous Flow = 0.33 L/s/ha

Pipe Design Parameters

Maximum Velocity = 3.00 m/s
 Minimum Velocity = 0.60 m/s
 Manning's n = 0.013

LOCATION			RESIDENTIAL				COMMERCIAL		INDUSTRIAL			INSTITUTIONAL		C+I+I	INFILTRATION			TOTAL FLOW, Q	PIPE									
STREET	FROM	TO	AREA	POP.	ACCU. AREA	PEAK FLOW	PEAK FLOW	AREA	ACCU. AREA	AREA	ACCU. AREA	PEAK FLOW	AREA	ACCU. AREA	PEAK FLOW	TOTAL AREA	ACCU. AREA		INFILT. FLOW	LENGTH	DIA.	SLOPE	MATERIAL	CAP. Q(FULL)	VEL. V(FULL)	Q/Q(FULL)	Approx. V/V(FULL)	Approx. V(ACT.)
			(Ha)		(Ha)		(L/s)	(Ha)	(Ha)	(Ha)	(Ha)	(L/s)	(Ha)	(Ha)	(L/s)	(Ha)	(Ha)	(L/s)	(L/s)	(m)	(mm)	(%)		(L/s)	(m/s)	(%)	(%)	(m/s)
	BLDG 1	SAN MH01						0.074	0.074						0.036	0.074	0.074	0.02	0.06	17.5	150	6.0%	PVC	37.3	2.1	0.16	17.3	0.37
	BLDG 2 & 3	SAN MH01						0.242	0.242	0.246	0.246	7.75			0.890	0.488	0.488	0.16	1.05	33.5	150	3.0%	PVC	26.4	1.5	3.98	48.6	0.73
	SAN MH01	SAN MH02																	1.11	45.8	150	2.0%	PVC	21.5	1.2	5.16	52.5	0.64
	SAN MH02	SAN MH03																	1.11	20.3	150	5.0%	PVC	34.1	1.9	3.26	45.8	0.88
	SAN MH03	EX. SAN Sewer																	1.11	9.3	150	5.0%	PVC	34.1	1.9	3.26	49.5	0.95

Notes: Existing inverts and slopes are estimated. They are to be confirmed on-site.

APPENDIX E
Civil Engineering Drawings

PLAZA TRIM ROAD DEVELOPMENT LTD

1280 TRIM RD, ORLEANS

REVISION 07



KEY PLAN (N.T.S.)

DRAWING INDEX

DRAWING INDEX	
TITLE PAGE	
GENERAL NOTES	C001
SEDIMENT AND EROSION CONTROL PLAN	C101
DEMOLITION PLAN	C102
GRADING AND DRAINAGE PLAN	C301
SERVICING PLAN	C401
STORMWATER MANAGEMENT PLAN	C601
PRE-DEVELOPMENT WATERSHED PLAN	C701
POST-DEVELOPMENT WATERSHED PLAN	C702
CONSTRUCTION DETAIL PLAN	C901



LRL

ENGINEERING | INGÉNIERIE

5430 Canotek Road | Ottawa, ON, K1J 9G2
 www.lrl.ca | (613) 842-3434

CIVIL ENGINEERING SERVICES
 1280 TRIM RD, ORLEANS
 REV.07 - ISSUED FOR APPROVAL - OCTOBER 11th, 2024
 LRL PROJECT no: 230202



NOT AUTHENTIC UNLESS SIGNED AND DATED

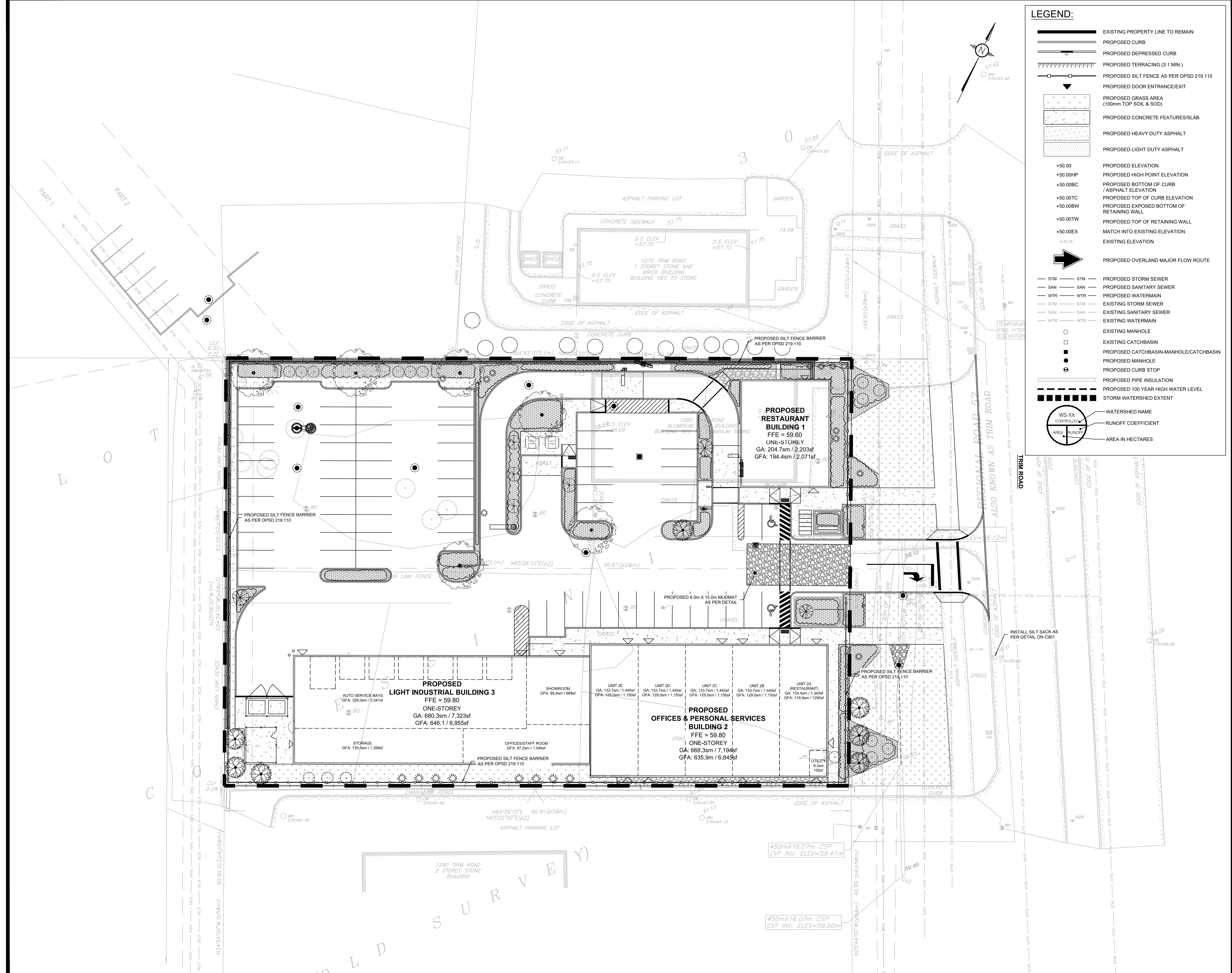

LEGEND:

- EXISTING PROPERTY LINE TO REMAIN
- PROPOSED CURB
- PROPOSED DEPRESSED CURB
- PROPOSED TERRACING (3:1 MIN.)
- PROPOSED SILT FENCE AS PER OPSD 219.110
- PROPOSED DOOR ENTRANCE/EKIT
- PROPOSED GRASS AREA (100mm TOP SOIL & SOD)
- PROPOSED CONCRETE FEATURES/SLAB
- PROPOSED HEAVY DUTY ASPHALT
- PROPOSED LIGHT DUTY ASPHALT
- PROPOSED ELEVATION
- PROPOSED HIGH POINT ELEVATION
- PROPOSED BOTTOM OF CURB ELEVATION
- PROPOSED TOP OF CURB ELEVATION
- PROPOSED EXPOSED BOTTOM OF RETAINING WALL
- PROPOSED TOP OF RETAINING WALL
- MATCH INTO EXISTING ELEVATION EXISTING ELEVATION
- PROPOSED OVERLAND MAJOR FLOW ROUTE
- PROPOSED STORM SEWER
- PROPOSED SANITARY SEWER
- PROPOSED WATERMAIN
- EXISTING STORM SEWER
- EXISTING SANITARY SEWER
- EXISTING WATERMAIN
- EXISTING MANHOLE
- EXISTING CATCHBASIN
- PROPOSED CATCHBASIN-MANHOLE/CATCHBASIN
- PROPOSED MANHOLE
- PROPOSED CURB STOP
- PROPOSED PIPE INSULATION
- PROPOSED 100 YEAR HIGH WATER LEVEL
- STORM WATERSHED EXTENT
- WATERSHED NAME
- RUNOFF COEFFICIENT
- AREA IN HECTARES

USE AND INTERPRETATION OF DRAWINGS

GENERAL CONDITIONS OF THE CONTRACT FOR CONSTRUCTION ARE PART OF THE CONTRACT DOCUMENTS AND DESCRIBE USE AND INTENT OF THE DRAWING. THE CONTRACT DOCUMENTS INCLUDE NOT ONLY THE DRAWINGS, BUT ALSO THE OWNER-CONTRACTOR AGREEMENTS, CONDITIONS OF THE CONTRACT, THE SPECIFICATIONS, ADDENDA, AND MODIFICATIONS ISSUED AFTER EXECUTION OF THE CONTRACT. THESE CONTRACT DOCUMENTS ARE COMPLEMENTARY, AND WHAT IS REQUIRED BY ANY ONE SHALL BE BINDING AS REQUIRED BY ALL. WORK NOT COMPLETELY DELINEATED HEREON SHALL BE CONSTRUCTED OF THE SAME MATERIALS AND DETAILED SIMILARLY AS WORK SHOWN MORE COMPLETELY ELSEWHERE IN THE CONTRACT DOCUMENTS.

BY USE OF THE DRAWINGS FOR CONSTRUCTION OF THE PROJECT, THE OWNER CONFIRMS THAT HE HAS REVIEWED AND APPROVED THE DRAWINGS. THE CONTRACTOR CONFIRMS THAT HE HAS VISITED THE SITE, FAMILIARIZED HIMSELF WITH THE LOCAL CONDITIONS, VERIFIED FIELD DIMENSIONS AND CORRELATED HIS OBSERVATIONS WITH THE REQUIREMENTS OF THE CONTRACT DOCUMENTS.

AS INSTRUMENTS OF SERVICE, ALL DRAWINGS, SPECIFICATIONS, CAD FILES OR OTHER ELECTRONIC MEDIA AND COPIES THEREOF FURNISHED BY THE ENGINEER ARE HIS PROPERTY. THEY ARE TO BE USED ONLY FOR THIS PROJECT AND ARE NOT TO BE USED ON ANY OTHER PROJECT, INCLUDING REPEATS OF THE PROJECT. CHANGES TO THE DRAWINGS MAY ONLY BE MADE BY THE ENGINEER.

UNLESS THE REVISION TITLE IS "ISSUED FOR CONSTRUCTION", THESE DRAWINGS SHALL BE CONSIDERED PRELIMINARY AND SHALL NOT BE USED AS A CONSTRUCTION DOCUMENT.

THESE DRAWINGS ILLUSTRATE THE WORK TO BE DONE. THE ENGINEER IS NOT RESPONSIBLE FOR THE MEANS, METHODS, TECHNIQUES, SEQUENCES, AND PROCEDURES USED TO DO THE WORK, OR THE SAFETY ASPECTS OF CONSTRUCTION, AND NOTHING ON THESE DRAWINGS EXPRESSED OR IMPLIED CHANGES THIS CONDITION. CONTRACTOR SHALL DETERMINE ALL CONDITIONS AT THE SITE AND SHALL BE RESPONSIBLE FOR KNOWING HOW THEY AFFECT THE WORK. SUBMITTAL OF A BID TO PERFORM THIS WORK IS ACKNOWLEDGEMENT OF THE RESPONSIBILITIES, AND THAT THEY HAVE BEEN FULLY CONSIDERED IN PLANNING OF THE WORK, AND THE BID PRICE. NO CLAIMS FOR EXTRA CHARGES DUE TO THESE CONDITIONS WILL BE FORTHCOMING.

UNAUTHORIZED CHANGES:

IN THE EVENT THE CLIENT, THE CLIENT'S CONTRACTORS OR SUBCONTRACTORS, OR ANYONE FOR WHOM THE CLIENT IS LEGALLY LIABLE MAKES OR PERMITS TO BE MADE ANY CHANGES TO ANY REPORTS, PLANS, SPECIFICATIONS OR OTHER CONSTRUCTION DOCUMENTS PREPARED BY LRL ASSOCIATES LTD. (LRL) WITHOUT OBTAINING LRL'S PRIOR WRITTEN CONSENT, THE CLIENT SHALL ASSUME FULL RESPONSIBILITY FOR THE RESULTS OF SUCH CHANGES. THEREFORE THE CLIENT AGREES TO WAIVE ANY CLAIM AGAINST LRL AND TO RELEASE LRL FROM ANY LIABILITY ARISING DIRECTLY OR INDIRECTLY FROM SUCH UNAUTHORIZED CHANGES.

IN ADDITION, THE CLIENT AGREES TO THE FULLEST EXTENT PERMITTED BY LAW, TO INDEMNIFY AND HOLD HARMLESS LRL FROM ANY DAMAGES, LIABILITIES OR COST, INCLUDING REASONABLE ATTORNEY'S FEES AND COST OF DEFENSE, ARISING FROM SUCH CHANGES.

GENERAL NOTES:

EXISTING SERVICES AND UTILITIES SHOWN ON THESE DRAWINGS ARE TAKEN FROM THE BEST AVAILABLE RECORDS, BUT MAY NOT BE COMPLETE OR TO DATE. CONTRACTOR SHALL VERIFY IN FIELD FOR LOCATION AND ELEVATION OF PIPES AND CHECK WITH THE UTILITY COMPANIES BEFORE DIGGING OR PERFORMING WORK.

CONTRACTOR IS ADVISED TO COLLECT INFORMATION ON SOIL CONDITIONS BEFORE START OF CONSTRUCTION.

THE ENGINEER WAIVES ANY AND ALL RESPONSIBILITY AND LIABILITY FOR PROBLEMS WHICH ARISE FROM FAILURE TO FOLLOW THESE PLANS, SPECIFICATIONS AND TO OBTAIN NOTES THEY CONVEY, OR FOR PROBLEMS WHICH ARISE FROM OTHERS' FAILURE TO OBTAIN AND/OR FOLLOW THE ENGINEER'S GUIDANCE WITH RESPECT TO ANY ERRORS, OMISSIONS, INCONSISTENCIES, AMBIGUITIES OR CONFLICTS WHICH ARE ALLEGED.

CONTRACTOR TO VERIFY ALL DIMENSIONS AND NOTIFY THE ENGINEER OF ANY DISCREPANCIES BEFORE WORK COMMENCES. DO NOT SCALE DRAWINGS.

5m 10m
SCALE: 1:250

SUBJECT FOR APPROVAL

No.	REVISIONS	BY	DATE
07	ISSUED FOR APPROVAL	M.L.	11 OCT 2024
06	ISSUED FOR APPROVAL	M.L.	08 AUG 2024
05	ISSUED FOR APPROVAL	S.V.	30 JUL 2024
04	ISSUED FOR APPROVAL	M.L.	28 JUN 2024
03	ISSUED FOR APPROVAL	M.L.	29 JAN 2024
02	ISSUED FOR APPROVAL	M.L.	25 OCT 2023
01	ISSUED FOR COORDINATION	M.L.	06 OCT 2023

NOT AUTHENTIC UNLESS SIGNED AND DATED

LICENSED PROFESSIONAL ENGINEER
M. BASNET
100501996
PROVINCE OF ONTARIO

LRL
ENGINEERING | INGENIERIE
5430 Canotek Road | Ottawa, ON, K1J 9G2
www.lrl.ca | (613) 842-3434

CLIENT
TRIM WORKS DEVELOPMENT LTD

DESIGNED BY: M.L. DRAWN BY: M.L. APPROVED BY: M.B.

PROJECT
PLAZA TRIM ROAD DEVELOPMENT
1280 TRIM RD,
OTTAWA, ON

DRAWING TITLE
EROSION AND SEDIMENT CONTROL PLAN

PROJECT NO. 230202
DATE APRIL 2023
C101

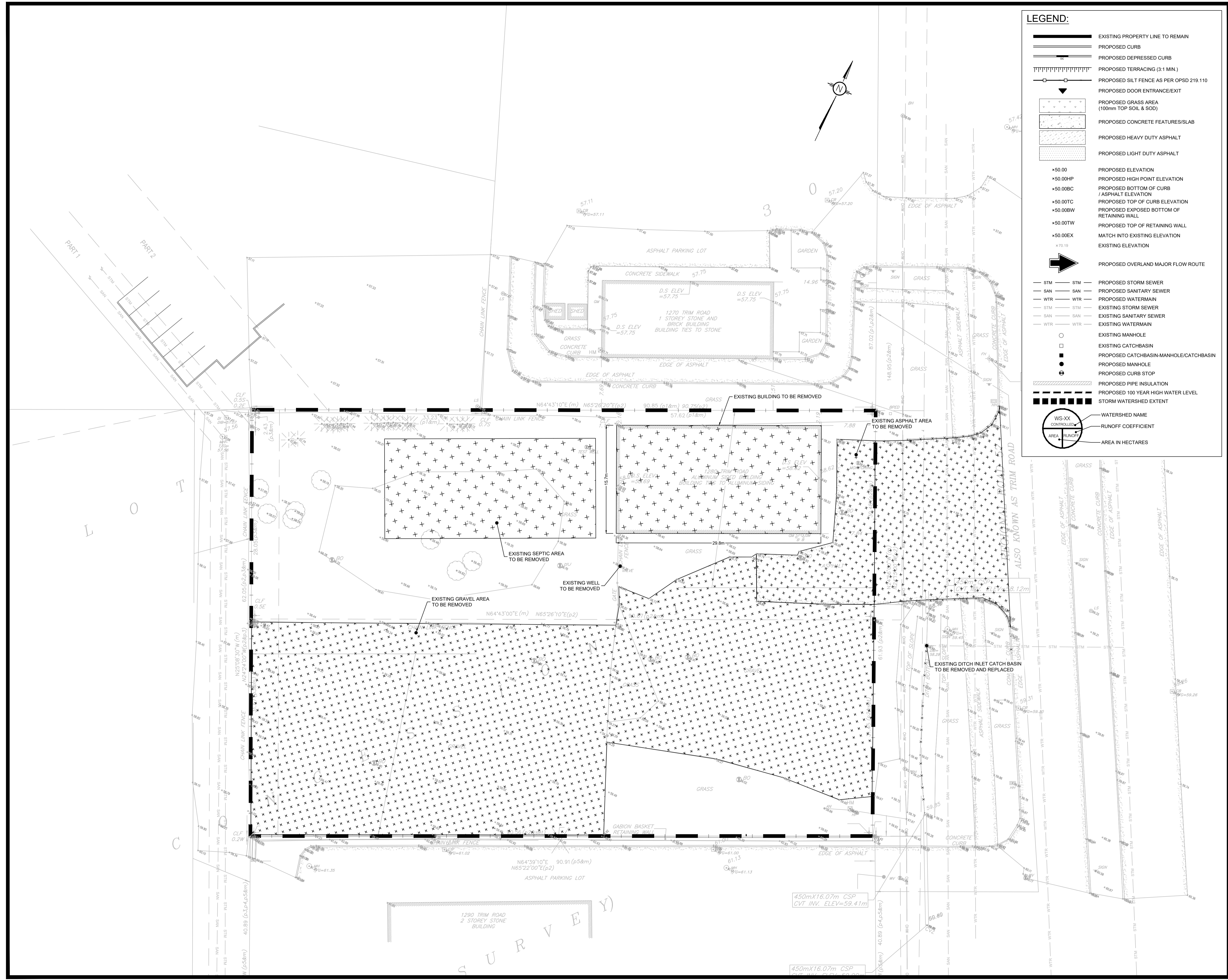

LEGEND:

- EXISTING PROPERTY LINE TO REMAIN
- PROPOSED CURB
- PROPOSED DEPRESSED CURB
- PROPOSED TERRACING (3:1 MIN.)
- PROPOSED SILT FENCE AS PER OPSD 219.110
- PROPOSED DOOR ENTRANCE/EXIT
- PROPOSED GRASS AREA (100mm TOP SOIL & SOD)
- PROPOSED CONCRETE FEATURES/SLAB
- PROPOSED HEAVY DUTY ASPHALT
- PROPOSED LIGHT DUTY ASPHALT
- PROPOSED ELEVATION
- PROPOSED HIGH POINT ELEVATION
- PROPOSED BOTTOM OF CURB
- PROPOSED TOP OF CURB ELEVATION
- PROPOSED EXPOSED BOTTOM OF RETAINING WALL
- PROPOSED TOP OF RETAINING WALL
- MATCH INTO EXISTING ELEVATION
- EXISTING ELEVATION
- PROPOSED OVERLAND MAJOR FLOW ROUTE
- STM PROPOSED STORM SEWER
- SAN PROPOSED SANITARY SEWER
- WTR PROPOSED WATERMAIN
- STM EXISTING STORM SEWER
- SAN EXISTING SANITARY SEWER
- WTR EXISTING WATERMAIN
- EXISTING MANHOLE
- EXISTING CATCHBASIN
- PROPOSED CATCHBASIN-MANHOLE/CATCHBASIN
- PROPOSED MANHOLE
- PROPOSED CURBS STOP
- PROPOSED PIPE INSULATION
- PROPOSED 100 YEAR HIGH WATER LEVEL
- STORM WATERSHED EXTENT
- WS-X WATERSHED NAME
- AREA RUNOFF COEFFICIENT
- AREA IN HECTARES

USE AND INTERPRETATION OF DRAWINGS

GENERAL CONDITIONS OF THE CONTRACT FOR CONSTRUCTION ARE PART OF THE CONTRACT DOCUMENTS AND DESCRIBE USE AND INTENT OF THE DRAWING. THE CONTRACT DOCUMENTS INCLUDE NOT ONLY THE DRAWINGS, BUT ALSO THE OWNER-CONTRACTOR AGREEMENTS, CONDITIONS OF THE CONTRACT, THE SPECIFICATIONS, ADDENDA, AND MODIFICATIONS ISSUED AFTER EXECUTION OF THE CONTRACT. THESE CONTRACT DOCUMENTS ARE COMPLEMENTARY, AND WHAT IS REQUIRED BY ANY ONE SHALL BE BINDING AS IF REQUIRED BY ALL. WORK NOT COMPLETELY DELINEATED HEREON SHALL BE CONSTRUCTED OF THE SAME MATERIALS AND DETAIL AS SHOWN MORE COMPLETELY ELSEWHERE IN THE CONTRACT DOCUMENTS.

BY USE OF THE DRAWINGS FOR CONSTRUCTION OF THE PROJECT, THE OWNER CONFIRMS THAT HE HAS REVIEWED AND APPROVED THE DRAWINGS. THE CONTRACTOR CONFIRMS THAT HE HAS VISITED THE SITE, FAMILIARIZED HIMSELF WITH THE LOCAL CONDITIONS, VERIFIED FIELD DIMENSIONS AND CORRELATED HIS OBSERVATIONS WITH THE REQUIREMENTS OF THE CONTRACT DOCUMENTS.

AS INSTRUMENTS OF SERVICE, ALL DRAWINGS, SPECIFICATIONS, CAD FILES OR OTHER ELECTRONIC MEDIA AND COPIES THEREOF FURNISHED BY THE ENGINEER ARE HIS PROPERTY. THEY ARE TO BE USED ONLY FOR THIS PROJECT AND ARE NOT TO BE USED ON ANY OTHER PROJECT, INCLUDING REPEATS OF THE PROJECT. CHANGES TO THE DRAWINGS MAY ONLY BE MADE BY THE ENGINEER.

UNLESS THE REVISION TITLE IS "ISSUED FOR CONSTRUCTION", THESE DRAWINGS SHALL BE CONSIDERED PRELIMINARY AND SHALL NOT BE USED AS A CONSTRUCTION DOCUMENT.

THESE DRAWINGS ILLUSTRATES THE WORK TO BE DONE. THE ENGINEER IS NOT RESPONSIBLE FOR THE MEANS, METHODS, TECHNIQUES, SEQUENCES, AND PROCEDURES USED TO DO THE WORK, OR THE SAFETY ASPECTS OF CONSTRUCTION, AND NOTHING ON THESE DRAWINGS EXPRESSED OR IMPLIED CHANGES THIS CONDITION. CONTRACTOR SHALL DETERMINE ALL CONDITIONS AT THE SITE AND SHALL BE RESPONSIBLE FOR KNOWING HOW THEY AFFECT THE WORK. SUBMITTAL OF A BID TO PERFORM THIS WORK IS ACKNOWLEDGEMENT OF THE RESPONSIBILITIES, AND THAT THEY HAVE BEEN FULLY CONSIDERED IN PLANNING OF THE WORK, AND THE BID PRICE. NO CLAIMS FOR EXTRA CHARGES DUE TO THESE CONDITIONS WILL BE FORTHCOMING.

UNAUTHORIZED CHANGES:

IN THE EVENT THE CLIENT, THE CLIENT'S CONTRACTORS OR SUBCONTRACTORS, OR ANYONE FOR WHOM THE CLIENT IS LEGALLY LIABLE MAKES OR PERMITS TO BE MADE ANY CHANGES TO ANY REPORTS, PLANS, SPECIFICATIONS OR OTHER CONSTRUCTION DOCUMENTS PREPARED BY ASSOCIATES LTD. (LRL) WITHOUT OBTAINING LRL'S PRIOR WRITTEN CONSENT, THE CLIENT SHALL ASSUME FULL RESPONSIBILITY FOR THE RESULTS OF SUCH CHANGES. THEREFORE THE CLIENT AGREES TO WAIVE ANY CLAIM AGAINST LRL AND TO RELEASE LRL FROM ANY LIABILITY ARISING DIRECTLY OR INDIRECTLY FROM SUCH UNAUTHORIZED CHANGES.

IN ADDITION, THE CLIENT AGREES TO INCLUDE IN ANY CONTRACTS FOR CONSTRUCTION APPROPRIATE LANGUAGE THAT PROHIBITS THE CONTRACTOR OR ANY SUBCONTRACTORS OF ANY TIER FROM MAKING ANY CHANGES OR MODIFICATIONS TO LRL'S CONSTRUCTION DOCUMENTS WITHOUT THE PRIOR WRITTEN APPROVAL OF LRL AND THAT FURTHER REQUIRES THE CONTRACTOR TO INDEMNIFY BOTH LRL AND THE CLIENT FROM ANY LIABILITY OR COST ARISING FROM SUCH CHANGES MADE WITHOUT SUCH PROPER AUTHORIZATION.

GENERAL NOTES:

EXISTING SERVICES AND UTILITIES SHOWN ON THESE DRAWINGS ARE TAKEN FROM THE BEST AVAILABLE RECORDS, BUT MAY NOT BE COMPLETE OR TO DATE. CONTRACTOR SHALL VERIFY IN FIELD FOR LOCATION AND ELEVATION OF PIPES AND CHECK WITH THE UTILITY COMPANIES BEFORE DIGGING OR PERFORMING WORK.

CONTRACTOR IS ADVISED TO COLLECT INFORMATION ON SOIL CONDITIONS BEFORE START OF CONSTRUCTION.

THE ENGINEER WAIVES ANY AND ALL RESPONSIBILITY AND LIABILITY FOR PROBLEMS WHICH ARISE FROM FAILURE TO FOLLOW THESE PLANS, SPECIFICATIONS AND THE DESIGN INTENT THEY CONVEY, OR FOR PROBLEMS WHICH ARISE FROM OTHER FAILURE TO OBTAIN AND/OR FOLLOW THE ENGINEER'S GUIDANCE WITH RESPECT TO ANY ERRORS, OMISSIONS, INCONSISTENCIES AMBIGUITIES OR CONFLICTS WHICH ARE ALLEGED.

CONTRACTOR TO VERIFY ALL DIMENSIONS AND NOTIFY THE ENGINEER OF ANY DISCREPANCIES BEFORE WORK COMMENCES. DO NOT SCALE DRAWINGS.

SCALE: 1:250

SUBJECT FOR APPROVAL

No.	REVISIONS	BY	DATE
07	ISSUED FOR APPROVAL	M.L.	11 OCT 2024
06	ISSUED FOR APPROVAL	M.L.	08 AUG 2024
05	ISSUED FOR APPROVAL	S.V.	30 JUL 2024
04	ISSUED FOR APPROVAL	M.L.	28 JUN 2024
03	ISSUED FOR APPROVAL	M.L.	29 JAN 2024
02	ISSUED FOR APPROVAL	M.L.	25 OCT 2023
01	ISSUED FOR COORDINATION	M.L.	06 OCT 2023



NOT AUTHENTIC UNLESS SIGNED AND DATED

LRL
ENGINEERING | INGÉNIERIE
5430 Canotek Road | Ottawa, ON, K1J 9G2
www.lrl.ca | (613) 842-3434

CLIENT
TRIM WORKS DEVELOPMENT LTD

DESIGNED BY: M.L. DRAWN BY: M.L. APPROVED BY: M.B.

PROJECT
**PLAZA TRIM ROAD DEVELOPMENT
1280 TRIM RD,
OTTAWA, ON**

DRAWING TITLE
DEMOLITION PLAN

PROJECT NO.
230202

DATE
APRIL 2023

C102

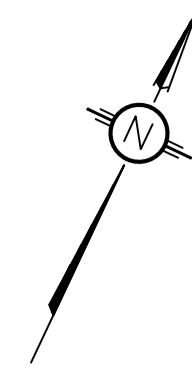

PAVEMENT STRUCTURE

COURSE	MATERIAL	THICKNESS (mm)	
		AUTOMOBILE PARKING	TRUCK ROUTE (HEAVY TRAFFIC)
SURFACE	HL 3 A/C (PG 58-34)	50	40
BINDER	HL 8 A/C (PG 58-34)	-	50
BASECOURSE	OPSS GRANULAR "A"	150	150
SUBBASE	OPSS GRANULAR "B" TYPE II	350	450

NOTE:
 IN PREPARATION FOR PAVEMENT CONSTRUCTION AT THIS SITE, ANY SURFICIAL OR NEAR SURFACE/SUBGRADE LEVEL TOPSOIL AND ANY SOFT, WET OR DELETERIOUS MATERIALS SHOULD BE REMOVED FROM THE PROPOSED PAVED AREAS. THE EXPOSED SUBGRADE SHOULD BE INSPECTED AND APPROVED BY GEOTECHNICAL PERSONNEL AND ANY SOFT AREAS EVIDENT SHOULD BE SUBEXCAVATED AND REPLACED WITH SUITABLE EARTH BORROW APPROVED BY THE GEOTECHNICAL ENGINEER. THE SUBGRADE SHOULD BE SHAPED AND CROWNED TO PROMOTE DRAINAGE OF THE SITE DRAINAGE STRUCTURES. FOLLOWING APPROVAL OF THE PREPARATION OF THE SUBGRADE, THE PAVEMENT GRANULARS MAY BE PLACED. REFER TO GEOTECHNICAL REPORT PREPARED BY LRL ENGINEERING, DATED MAY 2023.

LEGEND:

- EXISTING PROPERTY LINE TO REMAIN
- PROPOSED CURB
- PROPOSED DEPRESSED CURB
- PROPOSED TERRACING (3:1 MIN.)
- PROPOSED SILT FENCE AS PER OPSD 219.110
- PROPOSED DOOR ENTRANCE/EXIST
- PROPOSED GRASS AREA (100mm TOP SOIL & SOD)
- PROPOSED CONCRETE FEATURES/SLAB
- PROPOSED HEAVY DUTY ASPHALT
- PROPOSED LIGHT DUTY ASPHALT
- PROPOSED ELEVATION
- PROPOSED HIGH POINT ELEVATION
- PROPOSED BOTTOM OF CURB (ASPHALT ELEVATION)
- PROPOSED TOP OF CURB ELEVATION
- PROPOSED BOTTOM OF RETAINING WALL
- PROPOSED TOP OF RETAINING WALL
- MATCH INTO EXISTING ELEVATION
- EXISTING ELEVATION
- PROPOSED OVERLAND MAJOR FLOW ROUTE
- PROPOSED STORM SEWER
- PROPOSED SANITARY SEWER
- PROPOSED WATERMAIN
- EXISTING STORM SEWER
- EXISTING SANITARY SEWER
- EXISTING WATERMAIN
- EXISTING MANHOLE
- EXISTING CATCHBASIN
- PROPOSED CATCHBASIN-MANHOLE/CATCHBASIN
- PROPOSED MANHOLE
- PROPOSED CURB STOP
- PROPOSED PIPE INSULATION
- PROPOSED 100 YEAR HIGH WATER LEVEL
- STORM WATERSHED EXTENT
- WATERSHED NAME
- RUNOFF COEFFICIENT
- AREA IN HECTARES

USE AND INTERPRETATION OF DRAWINGS

GENERAL CONDITIONS OF THE CONTRACT FOR CONSTRUCTION ARE PART OF THE CONTRACT DOCUMENTS AND DESCRIBE USE AND INTENT OF THE DRAWINGS. THE CONTRACTOR SHALL BE RESPONSIBLE FOR OBTAINING ALL NECESSARY PERMITS AND APPROVALS FROM THE LOCAL AUTHORITIES. THE CONTRACTOR SHALL BE RESPONSIBLE FOR OBTAINING ALL NECESSARY PERMITS AND APPROVALS FROM THE LOCAL AUTHORITIES. THE CONTRACTOR SHALL BE RESPONSIBLE FOR OBTAINING ALL NECESSARY PERMITS AND APPROVALS FROM THE LOCAL AUTHORITIES.

BY USE OF THE DRAWINGS FOR CONSTRUCTION OF THE PROJECT, THE OWNER CONFIRMS THAT HE HAS REVIEWED AND APPROVED THE DRAWINGS. THE CONTRACTOR CONFIRMS THAT HE HAS VISITED THE SITE, FAMILIARIZED HIMSELF WITH THE LOCAL CONDITIONS, VERIFIED FIELD DIMENSIONS AND CORRELATED HIS OBSERVATIONS WITH THE REQUIREMENTS OF THE CONTRACT DOCUMENTS.

AS INSTRUMENTS OF SERVICE, ALL DRAWINGS, SPECIFICATIONS, CAD FILES OR OTHER ELECTRONIC MEDIA AND COPIES THEREOF FURNISHED BY THE ENGINEER ARE HIS PROPERTY. THEY ARE TO BE USED ONLY FOR THIS PROJECT AND ARE NOT TO BE USED ON ANY OTHER PROJECT, INCLUDING REPEATS OF THE PROJECT. CHANGES TO THE DRAWINGS MAY ONLY BE MADE BY THE ENGINEER.

UNLESS THE REVISION TITLE IS ISSUED FOR CONSTRUCTION, THESE DRAWINGS SHALL BE CONSIDERED PRELIMINARY AND SHALL NOT BE USED AS A CONSTRUCTION DOCUMENT.

THESE DRAWINGS ILLUSTRATE THE WORK TO BE DONE. THE ENGINEER IS NOT RESPONSIBLE FOR THE MEANS, METHODS, TECHNIQUES, SEQUENCES, AND PROCEDURES USED TO DO THE WORK, OR THE SAFETY ASPECTS OF CONSTRUCTION, AND NOTHING ON THESE DRAWINGS EXPRESSED OR IMPLIED CHANGES THIS CONDITION. CONTRACTOR SHALL DETERMINE ALL CONDITIONS AT THE SITE AND SHALL BE RESPONSIBLE FOR KNOWING HOW THEY AFFECT THE WORK. SUBMITTAL OF A BID TO PERFORM THIS WORK IS A KNOWLEDGEABLE ACCEPTANCE OF THE RESPONSIBILITIES, AND THAT THEY HAVE BEEN FULLY CONSIDERED IN PLANNING OF THE WORK AND THE BID PRICE. NO CLAIMS FOR EXTRA CHARGES DUE TO THESE CONDITIONS WILL BE FORTHCOMING.

UNAUTHORIZED CHANGES:

IN THE EVENT THE CLIENT, THE CLIENT'S CONTRACTORS OR SUBCONTRACTORS, OR ANYONE FOR WHOM THE CLIENT IS LEGALLY LIABLE MAKES OR PERMITS TO BE MADE ANY CHANGES TO ANY REPORTS, PLANS, SPECIFICATIONS OR OTHER CONSTRUCTION DOCUMENTS PREPARED BY LRL ASSOCIATES LTD. (LRL) WITHOUT OBTAINING LRL'S PRIOR WRITTEN CONSENT, THE CLIENT SHALL ASSUME FULL RESPONSIBILITY FOR THE RESULTS OF SUCH CHANGES. THEREFORE THE CLIENT AGREES TO WAIVE ANY CLAIM AGAINST LRL AND TO RELEASE LRL FROM ANY LIABILITY ARISING DIRECTLY OR INDIRECTLY FROM SUCH UNAUTHORIZED CHANGES.

IN ADDITION, THE CLIENT AGREES TO THE FULLEST EXTENT PERMITTED BY LAW, TO INDEMNIFY AND HOLD HARMLESS LRL FROM ANY DAMAGES, LIABILITIES OR COST, INCLUDING REASONABLE ATTORNEY'S FEES AND COST OF DEFENSE, ARISING FROM SUCH CHANGES.

GENERAL NOTES:

EXISTING SERVICES AND UTILITIES SHOWN ON THESE DRAWINGS ARE TAKEN FROM THE BEST AVAILABLE RECORDS, BUT MAY NOT BE COMPLETE OR TO DATE. CONTRACTOR SHALL VERIFY IN FIELD FOR LOCATION AND DEPTH OF PIPES AND CHECK WITH THE UTILITY COMPANIES BEFORE DIGGING OR PERFORMING WORK.

CONTRACTOR IS ADVISED TO COLLECT INFORMATION ON SOIL CONDITIONS BEFORE START OF CONSTRUCTION.

THE ENGINEER WAIVES ANY AND ALL RESPONSIBILITY AND LIABILITY FOR PROBLEMS WHICH ARISE FROM FAILURE TO FOLLOW THESE PLANS, SPECIFICATIONS AND TO OBTAIN NECESSARY PERMITS, APPROVALS OR FOR PROBLEMS WHICH ARISE FROM OTHERS' FAILURE TO OBTAIN AND/OR FOLLOW THE ENGINEER'S GUIDANCE WITH RESPECT TO ANY ERRORS, OMISSIONS, INCONSISTENCIES, AMBIGUITIES OR CONFLICTS WHICH ARE ALLEGED.

CONTRACTOR TO VERIFY ALL DIMENSIONS AND NOTIFY THE ENGINEER OF ANY DISCREPANCIES BEFORE WORK COMMENCES. DO NOT SCALE DRAWINGS.



SUBJECT FOR APPROVAL

No.	REVISIONS	BY	DATE
07	ISSUED FOR APPROVAL	M.L.	11 OCT 2024
06	ISSUED FOR APPROVAL	M.L.	08 AUG 2024
05	ISSUED FOR APPROVAL	S.V.	30 JUL 2024
04	ISSUED FOR APPROVAL	M.L.	28 JUN 2024
03	ISSUED FOR APPROVAL	M.L.	29 JAN 2024
02	ISSUED FOR APPROVAL	M.L.	25 OCT 2023
01	ISSUED FOR COORDINATION	M.L.	06 OCT 2023



NOT AUTHENTIC UNLESS SIGNED AND DATED



CLIENT: TRIM WORKS DEVELOPMENT LTD

DESIGNED BY: M.L. DRAWN BY: M.L. APPROVED BY: M.B.

PROJECT: PLAZA TRIM ROAD DEVELOPMENT
 1280 TRIM RD,
 OTTAWA, ON

DRAWING TITLE: GRADING AND DRAINAGE PLAN

PROJECT NO: 230202
 DATE: APRIL 2023
C301

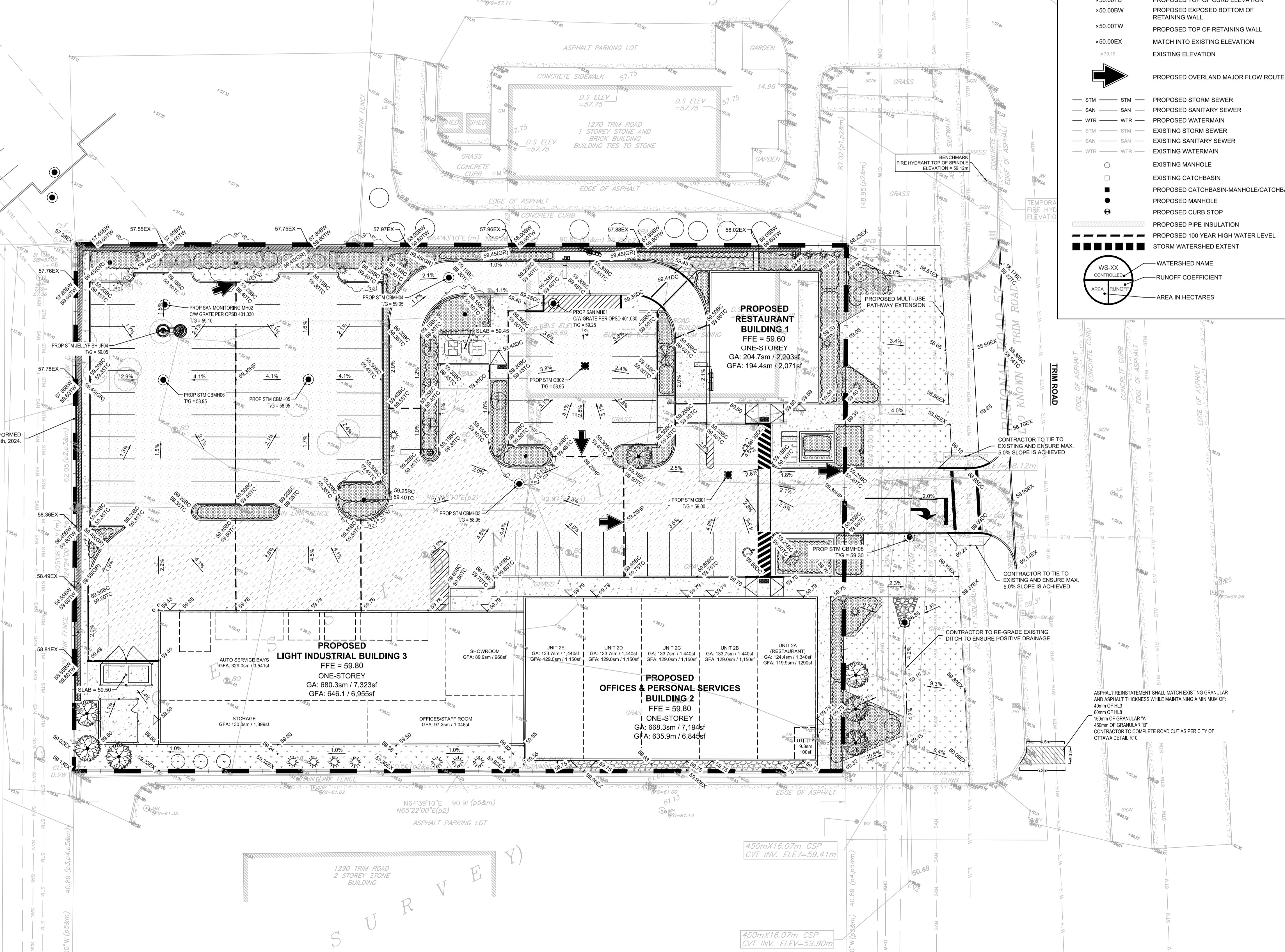

Crossing Table							
Crossing #	WTR	inv./obv.	STM	inv./obv.	SAN	inv./obv.	Depth Separation (m)
CR-01	N/A	55.94	inv.	55.33	obv.		0.61
CR-02	N/A	57.24	inv.	56.30	obv.		0.94
CR-03	N/A	57.36	inv.	56.89	obv.		0.47
CR-04	58.08	inv.	N/A	57.58	obv.		0.50
CR-05	N/A	57.45	inv.	56.95	obv.		0.50
CR-06	N/A	57.64	inv.	57.34	obv.		0.30
CR-07	57.05	obv.	57.76	inv.	N/A		0.71

LEGEND:

- EXISTING PROPERTY LINE TO REMAIN
- PROPOSED CURB
- PROPOSED DEPRESSED CURB
- PROPOSED TERRACING (3:1 MIN.)
- PROPOSED SILT FENCE AS PER OPSD 219.110
- PROPOSED DOOR ENTRANCE/EXIT
- PROPOSED GRASS AREA (100mm TOP SOIL & SOD)
- PROPOSED CONCRETE FEATURES/SLAB
- PROPOSED HEAVY DUTY ASPHALT
- PROPOSED LIGHT DUTY ASPHALT
- PROPOSED ELEVATION
- PROPOSED HIGH POINT ELEVATION
- PROPOSED BOTTOM OF CURB / ASPHALT ELEVATION
- PROPOSED TOP OF CURB ELEVATION
- PROPOSED EXPOSED BOTTOM OF RETAINING WALL
- PROPOSED TOP OF RETAINING WALL
- MATCH INTO EXISTING ELEVATION
- EXISTING ELEVATION
- PROPOSED OVERLAND MAJOR FLOW ROUTE
- PROPOSED STORM SEWER
- PROPOSED SANITARY SEWER
- PROPOSED WATERMAIN
- EXISTING STORM SEWER
- EXISTING SANITARY SEWER
- EXISTING WATERMAIN
- EXISTING MANHOLE
- EXISTING CATCHBASIN
- PROPOSED CATCHBASIN-MANHOLE/CATCHBASIN
- PROPOSED MANHOLE
- PROPOSED CURB STOP
- PROPOSED PIPE INSULATION
- PROPOSED 100 YEAR HIGH WATER LEVEL
- STORM WATERSHED EXTENT
- WATERSHED NAME
- RUNOFF COEFFICIENT
- AREA IN HECTARES

USE AND INTERPRETATION OF DRAWINGS

GENERAL CONDITIONS OF THE CONTRACT FOR CONSTRUCTION ARE PART OF THE CONTRACT DOCUMENTS AND DESCRIBE THE USE AND INTENT OF THE DRAWINGS. THE CONTRACTOR SHALL BE RESPONSIBLE FOR OBTAINING ALL NECESSARY PERMITS AND APPROVALS FROM THE LOCAL AUTHORITIES. THE CONTRACTOR SHALL BE RESPONSIBLE FOR OBTAINING ALL NECESSARY PERMITS AND APPROVALS FROM THE LOCAL AUTHORITIES. THE CONTRACTOR SHALL BE RESPONSIBLE FOR OBTAINING ALL NECESSARY PERMITS AND APPROVALS FROM THE LOCAL AUTHORITIES.

BY USE OF THE DRAWINGS FOR CONSTRUCTION OF THE PROJECT, THE OWNER AGREES THAT HE HAS REVIEWED AND APPROVED THE DRAWINGS. THE CONTRACTOR SHALL BE RESPONSIBLE FOR OBTAINING ALL NECESSARY PERMITS AND APPROVALS FROM THE LOCAL AUTHORITIES. THE CONTRACTOR SHALL BE RESPONSIBLE FOR OBTAINING ALL NECESSARY PERMITS AND APPROVALS FROM THE LOCAL AUTHORITIES.

UNLESS THE REVISION TITLE IS ISSUED FOR CONSTRUCTION, THESE DRAWINGS SHALL BE CONSIDERED PRELIMINARY AND SHALL NOT BE USED AS A CONSTRUCTION DOCUMENT.

THESE DRAWINGS ILLUSTRATE THE WORK TO BE DONE. THE ENGINEER IS NOT RESPONSIBLE FOR THE MEANS, METHODS, TECHNIQUES, SEQUENCES, AND PROCEDURES USED TO DO THE WORK, OR THE SAFETY ASPECTS OF CONSTRUCTION, AND NOTHING ON THESE DRAWINGS EXPRESSED OR IMPLIED CHANGES THIS CONDITION. CONTRACTOR SHALL DETERMINE ALL CONDITIONS AT THE SITE AND SHALL BE RESPONSIBLE FOR KNOWING HOW THEY AFFECT THE WORK. SUBMITTAL OF A BID TO PERFORM THIS WORK IS AN ACKNOWLEDGEMENT OF THE RESPONSIBILITIES, AND THAT THEY HAVE BEEN FULLY CONSIDERED IN PLANNING OF THE WORK AND THE BID PRICE. NO CLAIMS FOR EXTRA CHARGES DUE TO THESE CONDITIONS WILL BE FORTHCOMING.

UNAUTHORIZED CHANGES: IN THE EVENT THE CLIENT, THE CLIENT'S CONTRACTORS OR SUBCONTRACTORS, OR ANYONE FOR WHOM THE CLIENT IS LEGALLY LIABLE MAKES OR PERMITS TO BE MADE ANY CHANGES TO ANY REPORTS, PLANS, SPECIFICATIONS OR OTHER CONSTRUCTION DOCUMENTS PREPARED BY LRL ASSOCIATES LTD. (LRL) WITHOUT OBTAINING LRL'S PRIOR WRITTEN CONSENT, THE CLIENT SHALL ASSUME FULL RESPONSIBILITY FOR THE RESULTS OF SUCH CHANGES. THEREFORE THE CLIENT AGREES TO WAIVE ANY CLAIM AGAINST LRL AND TO RELEASE LRL FROM ANY LIABILITY ARISING DIRECTLY OR INDIRECTLY FROM SUCH UNAUTHORIZED CHANGES.

IN ADDITION, THE CLIENT AGREES TO THE FULLEST EXTENT PERMITTED BY LAW, TO INDEMNIFY AND HOLD HARMLESS LRL FROM ANY DAMAGES, LIABILITIES OR COSTS, INCLUDING REASONABLE ATTORNEY'S FEES AND COST OF DEFENSE, ARISING FROM SUCH CHANGES.

EXISTING SERVICES AND UTILITIES SHOWN ON THESE DRAWINGS ARE TAKEN FROM THE BEST AVAILABLE RECORDS, BUT MAY NOT BE COMPLETE OR TO DATE. CONTRACTOR SHALL VERIFY IN FIELD FOR LOCATION AND DEPTHS OF PIPES AND CHECK WITH THE UTILITY COMPANIES BEFORE DIGGING OR PERFORMING WORK.

CONTRACTOR IS ADVISED TO COLLECT INFORMATION ON SOIL CONDITIONS BEFORE START OF CONSTRUCTION.

THE ENGINEER WAIVES ANY AND ALL RESPONSIBILITY AND LIABILITY FOR PROBLEMS WHICH ARISE FROM FAILURE TO FOLLOW THESE PLANS, SPECIFICATIONS AND TO OBTAIN NECESSARY PERMITS AND APPROVALS FROM THE LOCAL AUTHORITIES. THE CLIENT SHALL ASSUME FULL RESPONSIBILITY FOR THE RESULTS OF SUCH CHANGES. THEREFORE THE CLIENT AGREES TO WAIVE ANY CLAIM AGAINST LRL AND TO RELEASE LRL FROM ANY LIABILITY ARISING DIRECTLY OR INDIRECTLY FROM SUCH UNAUTHORIZED CHANGES.

CONTRACTOR TO VERIFY ALL DIMENSIONS AND NOTIFY THE ENGINEER OF ANY DISCREPANCIES BEFORE WORK COMMENCES. DO NOT SCALE DRAWINGS.

No.	REVISIONS	BY	DATE
07	ISSUED FOR APPROVAL	M.L.	11 OCT 2024
06	ISSUED FOR APPROVAL	M.L.	08 AUG 2024
05	ISSUED FOR APPROVAL	S.V.	30 JUL 2024
04	ISSUED FOR APPROVAL	M.L.	28 JUN 2024
03	ISSUED FOR APPROVAL	M.L.	29 JAN 2024
02	ISSUED FOR APPROVAL	M.L.	25 OCT 2023
01	ISSUED FOR COORDINATION	M.L.	06 OCT 2023

NOT AUTHENTIC UNLESS SIGNED AND DATED

LRL
ENGINEERING | INGÉNIERIE
5430 Canotek Road | Ottawa, ON, K1J 9G2
www.lrl.ca | (613) 842-3434

CLIENT
TRIM WORKS DEVELOPMENT LTD

DESIGNED BY: M.L. DRAWN BY: M.L. APPROVED BY: M.B.

PROJECT
**PLAZA TRIM ROAD DEVELOPMENT
1280 TRIM RD,
OTTAWA, ON**

DRAWING TITLE
SERVICING PLAN

PROJECT NO. 230202
DATE: APRIL 2023

C401

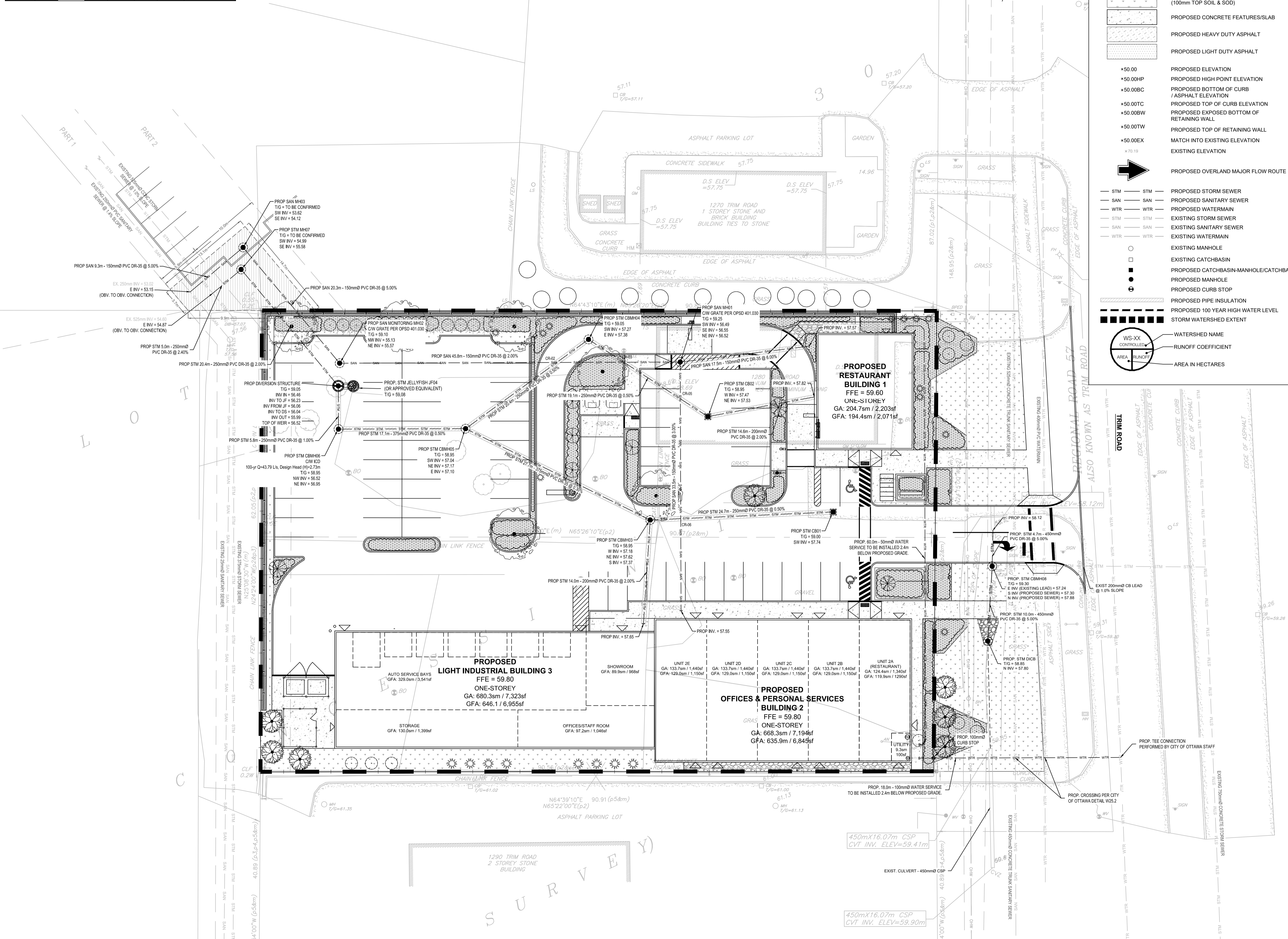

SUBJECT FOR APPROVAL

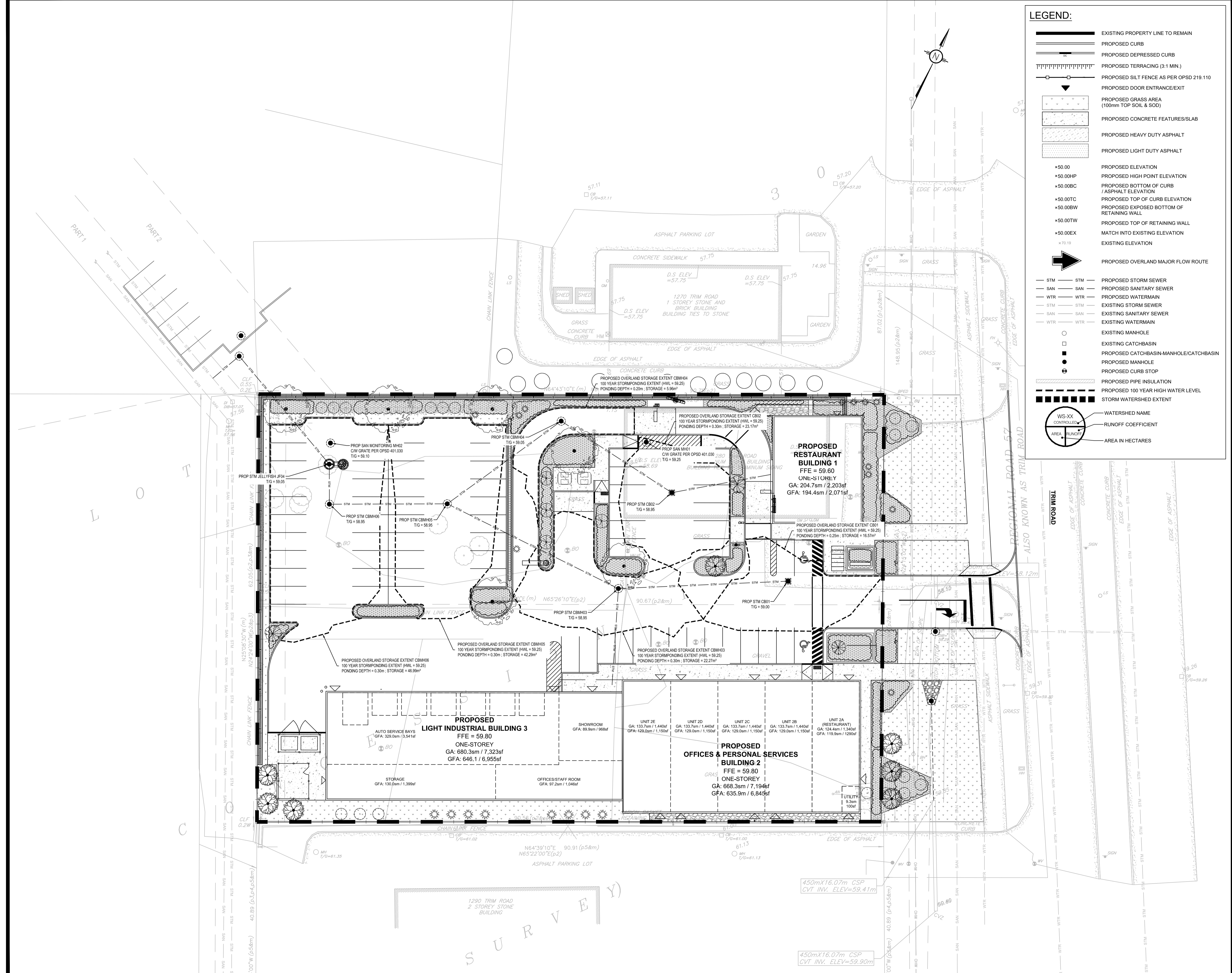

LEGEND:

- EXISTING PROPERTY LINE TO REMAIN
- PROPOSED CURB
- PROPOSED DEPRESSED CURB
- PROPOSED TERRACING (3:1 MIN.)
- PROPOSED SILT FENCE AS PER OPSD 219.110
- PROPOSED DOOR ENTRANCE/EEXIT
- PROPOSED GRASS AREA (100mm TOP SOIL & SOD)
- PROPOSED CONCRETE FEATURES/SLAB
- PROPOSED HEAVY DUTY ASPHALT
- PROPOSED LIGHT DUTY ASPHALT
- PROPOSED ELEVATION
- PROPOSED HIGH POINT ELEVATION
- PROPOSED BOTTOM OF CURB
- PROPOSED TOP OF CURB ELEVATION
- PROPOSED EXPOSED BOTTOM OF RETAINING WALL
- PROPOSED TOP OF RETAINING WALL
- MATCH INTO EXISTING ELEVATION
- EXISTING ELEVATION
- PROPOSED OVERLAND MAJOR FLOW ROUTE
- PROPOSED STORM SEWER
- PROPOSED SANITARY SEWER
- PROPOSED WATERMAIN
- EXISTING STORM SEWER
- EXISTING SANITARY SEWER
- EXISTING WATERMAIN
- EXISTING MANHOLE
- EXISTING CATCHBASIN
- PROPOSED CATCHBASIN/MANHOLE/CATCHBASIN
- PROPOSED MANHOLE
- PROPOSED CURB STOP
- PROPOSED PIPE INSULATION
- PROPOSED 100 YEAR HIGH WATER LEVEL
- STORM WATERSHED EXTENT
- WATERSHED NAME
- RUNOFF COEFFICIENT
- AREA IN HECTARES

USE AND INTERPRETATION OF DRAWINGS

GENERAL CONDITIONS OF THE CONTRACT FOR CONSTRUCTION ARE PART OF THE CONTRACT DOCUMENTS AND DESCRIBE USE AND INTENT OF THE DRAWING. THE CONTRACT DOCUMENTS INCLUDE NOT ONLY THE DRAWINGS, BUT ALSO THE OWNER-CONTRACTOR AGREEMENTS, CONDITIONS OF THE CONTRACT, THE SPECIFICATIONS, ADDENDA, AND MODIFICATIONS ISSUED AFTER EXECUTION OF THE CONTRACT. THESE CONTRACT DOCUMENTS ARE COMPLEMENTARY, AND WHAT IS REQUIRED BY ANY ONE SHALL BE BINDING AS REQUIRED BY ALL. WORK NOT COMPLETELY DELINEATED HEREON SHALL BE CONSTRUCTED OF THE SAME MATERIALS AND DETAILED SIMILARLY AS WORK SHOWN MORE COMPLETELY ELSEWHERE IN THE CONTRACT DOCUMENTS.

BY USE OF THE DRAWINGS FOR CONSTRUCTION OF THE PROJECT, THE OWNER CONFIRMS THAT HE HAS REVIEWED AND APPROVED THE DRAWINGS. THE CONTRACTOR CONFIRMS THAT HE HAS VISITED THE SITE, FAMILIARIZED HIMSELF WITH THE LOCAL CONDITIONS, VERIFIED FIELD DIMENSIONS AND CORRELATED HIS OBSERVATIONS WITH THE REQUIREMENTS OF THE CONTRACT DOCUMENTS.

AS INSTRUMENTS OF SERVICE, ALL DRAWINGS, SPECIFICATIONS, CAD FILES OR OTHER ELECTRONIC MEDIA AND COPIES THERE OF FURNISHED BY THE ENGINEER ARE HIS PROPERTY. THEY ARE TO BE USED ONLY FOR THIS PROJECT AND ARE NOT TO BE USED ON ANY OTHER PROJECT, INCLUDING REPEATS OF THE PROJECT. CHANGES TO THE DRAWINGS MAY ONLY BE MADE BY THE ENGINEER.

UNLESS THE REVISION TITLE IS ISSUED FOR CONSTRUCTION, THESE DRAWINGS SHALL BE CONSIDERED PRELIMINARY AND SHALL NOT BE USED AS A CONSTRUCTION DOCUMENT.

THESE DRAWINGS ILLUSTRATE THE WORK TO BE DONE. THE ENGINEER IS NOT RESPONSIBLE FOR THE MEANS, METHODS, TECHNIQUES, SEQUENCES, AND PROCEDURES USED TO DO THE WORK, OR THE SAFETY ASPECTS OF CONSTRUCTION, AND NOTHING ON THESE DRAWINGS EXPRESSED OR IMPLIED CHANGES THIS CONDITION. CONTRACTOR SHALL DETERMINE ALL CONDITIONS AT THE SITE AND SHALL BE RESPONSIBLE FOR KNOWING HOW THEY AFFECT THE WORK. SUBMITTAL OF A BID TO PERFORM THIS WORK IS A KNOWLEDGEABLE ACCEPTANCE OF THE RESPONSIBILITIES, AND THAT THEY HAVE BEEN FULLY CONSIDERED IN PLANNING OF THE WORK, AND THE BID PRICE. NO CLAIMS FOR EXTRA CHARGES DUE TO THESE CONDITIONS WILL BE FORTHCOMING.

UNAUTHORIZED CHANGES:

IN THE EVENT THE CLIENT, THE CLIENT'S CONTRACTORS OR SUBCONTRACTORS, OR ANYONE FOR WHOM THE CLIENT IS LEGALLY LIABLE MAKES OR PERMITS TO BE MADE ANY CHANGES TO ANY REPORTS, PLANS, SPECIFICATIONS OR OTHER CONSTRUCTION DOCUMENTS PREPARED BY LRL ASSOCIATES LTD. (LRL) WITHOUT OBTAINING LRL'S PRIOR WRITTEN CONSENT, THE CLIENT SHALL ASSUME FULL RESPONSIBILITY FOR THE RESULTS OF SUCH CHANGES. THEREFORE THE CLIENT AGREES TO WAIVE ANY CLAIM AGAINST LRL AND TO RELEASE LRL FROM ANY LIABILITY ARISING DIRECTLY OR INDIRECTLY FROM SUCH UNAUTHORIZED CHANGES.

IN ADDITION, THE CLIENT AGREES, TO THE FULLEST EXTENT PERMITTED BY LAW, TO INDEMNIFY AND HOLD HARMLESS LRL FROM ANY DAMAGES, LIABILITIES OR COST, INCLUDING REASONABLE ATTORNEY'S FEES AND COST OF DEFENSE, ARISING FROM SUCH CHANGES.

GENERAL NOTES:

EXISTING SERVICES AND UTILITIES SHOWN ON THESE DRAWINGS ARE TAKEN FROM THE BEST AVAILABLE RECORDS, BUT MAY NOT BE COMPLETE OR TO DATE. CONTRACTOR SHALL VERIFY IN FIELD FOR LOCATION AND DEPTHS OF PIPES AND CHECK WITH THE UTILITY COMPANIES BEFORE DIGGING OR PERFORMING WORK.

CONTRACTOR IS ADVISED TO COLLECT INFORMATION ON SOIL CONDITIONS BEFORE START OF CONSTRUCTION.

THE ENGINEER WAIVES ANY AND ALL RESPONSIBILITY AND LIABILITY FOR PROBLEMS WHICH ARISE FROM FAILURE TO FOLLOW THESE PLANS, SPECIFICATIONS AND TO ANY EXTENT THEY CONVEY, OR FOR PROBLEMS WHICH ARISE FROM OTHERS' FAILURE TO OBTAIN AND/OR FOLLOW THE ENGINEER'S GUIDANCE WITH RESPECT TO ANY ERRORS, OMISSIONS, INCONSISTENCIES, AMBIGUITIES OR CONFLICTS WHICH ARE ALLEGED.

CONTRACTOR TO VERIFY ALL DIMENSIONS AND NOTIFY THE ENGINEER OF ANY DISCREPANCIES BEFORE WORK COMMENCES. DO NOT SCALE DRAWINGS.

SCALE: 1:250

SUBJECT FOR APPROVAL

No.	REVISIONS	BY	DATE
07	ISSUED FOR APPROVAL	M.L.	11 OCT 2024
06	ISSUED FOR APPROVAL	M.L.	08 AUG 2024
05	ISSUED FOR APPROVAL	S.V.	30 JUL 2024
04	ISSUED FOR APPROVAL	M.L.	28 JUN 2024
03	ISSUED FOR APPROVAL	M.L.	29 JAN 2024
02	ISSUED FOR APPROVAL	M.L.	25 OCT 2023
01	ISSUED FOR COORDINATION	M.L.	06 OCT 2023

NOT AUTHENTIC UNLESS SIGNED AND DATED

LRL
ENGINEERING | INGENIERIE
5430 Canotek Road | Ottawa, ON, K1J 9G2
www.lrl.ca | (613) 842-3434

CLIENT: TRIM WORKS DEVELOPMENT LTD

DESIGNED BY: M.L. DRAWN BY: M.L. APPROVED BY: M.B.

PROJECT: PLAZA TRIM ROAD DEVELOPMENT
1280 TRIM RD,
OTTAWA, ON

DRAWING TITLE: STORMWATER MANAGEMENT PLAN

PROJECT NO: 230202
DATE: APRIL 2023
C601

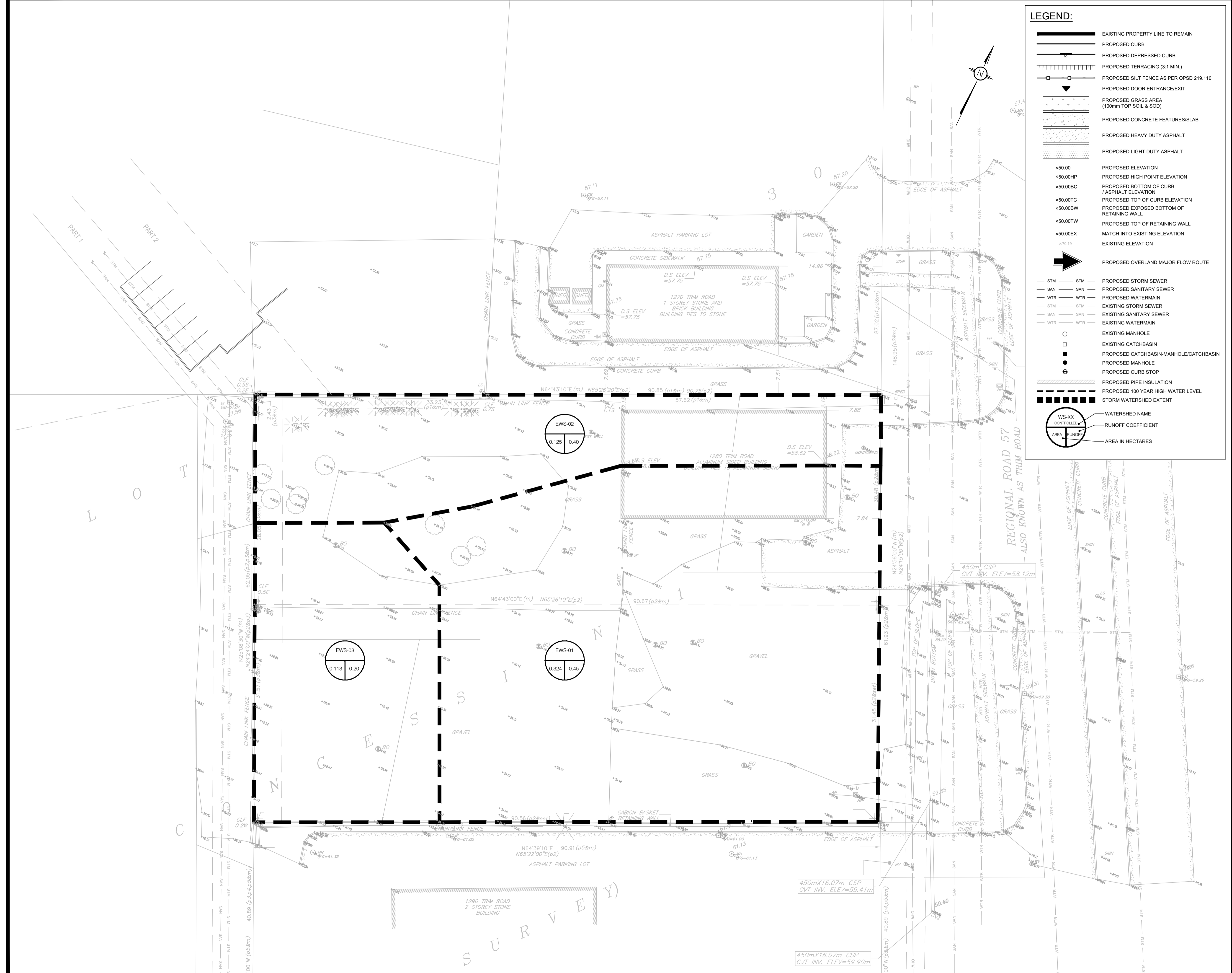

LEGEND:

- EXISTING PROPERTY LINE TO REMAIN
- PROPOSED CURB
- PROPOSED DEPRESSED CURB
- PROPOSED TERRACING (3:1 MIN.)
- PROPOSED SILT FENCE AS PER OPSD 219.110
- PROPOSED DOOR ENTRANCE/EXIT
- PROPOSED GRASS AREA (100mm TOP SOIL & SOD)
- PROPOSED CONCRETE FEATURES/SLAB
- PROPOSED HEAVY DUTY ASPHALT
- PROPOSED LIGHT DUTY ASPHALT
- PROPOSED ELEVATION
- PROPOSED HIGH POINT ELEVATION
- PROPOSED BOTTOM OF CURB ASPHALT ELEVATION
- PROPOSED TOP OF CURB ELEVATION
- PROPOSED EXPOSED BOTTOM OF RETAINING WALL
- PROPOSED TOP OF RETAINING WALL
- MATCH INTO EXISTING ELEVATION
- EXISTING ELEVATION
- PROPOSED OVERLAND MAJOR FLOW ROUTE
- PROPOSED STORM SEWER
- PROPOSED SANITARY SEWER
- PROPOSED WATERMAIN
- EXISTING STORM SEWER
- EXISTING SANITARY SEWER
- EXISTING WATERMAIN
- EXISTING MANHOLE
- EXISTING CATCHBASIN
- PROPOSED CATCHBASIN-MANHOLE/CATCHBASIN
- PROPOSED MANHOLE
- PROPOSED CURB STOP
- PROPOSED PIPE INSULATION
- PROPOSED 100 YEAR HIGH WATER LEVEL
- STORM WATERSHED EXTENT
- WATERSHED NAME
- RUNOFF COEFFICIENT
- AREA IN HECTARES

USE AND INTERPRETATION OF DRAWINGS

GENERAL CONDITIONS OF THE CONTRACT FOR CONSTRUCTION ARE PART OF THE CONTRACT DOCUMENTS AND DESCRIBE USE AND INTENT OF THE DRAWING. THE CONTRACT DOCUMENTS INCLUDE NOT ONLY THE DRAWINGS, BUT ALSO THE OWNER-CONTRACTOR AGREEMENTS, CONDITIONS OF THE CONTRACT, THE SPECIFICATIONS, ADDENDA, AND MODIFICATIONS ISSUED AFTER EXECUTION OF THE CONTRACT. THESE CONTRACT DOCUMENTS ARE COMPLEMENTARY, AND WHAT IS REQUIRED BY ANY ONE SHALL BE BINDING AS REQUIRED BY ALL. WORK NOT COMPLETELY DELINEATED HEREON SHALL BE CONSTRUCTED OF THE SAME MATERIALS AND DETAILED SIMILARLY AS WORK SHOWN MORE COMPLETELY ELSEWHERE IN THE CONTRACT DOCUMENTS.

BY USE OF THE DRAWINGS FOR CONSTRUCTION OF THE PROJECT, THE OWNER CONFIRMS THAT HE HAS REVIEWED AND APPROVED THE DRAWINGS. THE CONTRACTOR CONFIRMS THAT HE HAS VISITED THE SITE, FAMILIARIZED HIMSELF WITH THE LOCAL CONDITIONS, VERIFIED FIELD DIMENSIONS AND CORRELATED HIS OBSERVATIONS WITH THE REQUIREMENTS OF THE CONTRACT DOCUMENTS.

AS INSTRUMENTS OF SERVICE, ALL DRAWINGS, SPECIFICATIONS, CADD FILES OR OTHER ELECTRONIC MEDIA AND COPIES THERE OF FURNISHED BY THE ENGINEER ARE HIS PROPERTY. THEY ARE TO BE USED ONLY FOR THIS PROJECT AND ARE NOT TO BE USED ON ANY OTHER PROJECT, INCLUDING REPEATS OF THE PROJECT. CHANGES TO THE DRAWINGS MAY ONLY BE MADE BY THE ENGINEER.

UNLESS THE REVISION TITLE IS "ISSUED FOR CONSTRUCTION", THESE DRAWINGS SHALL BE CONSIDERED PRELIMINARY AND SHALL NOT BE USED AS A CONSTRUCTION DOCUMENT.

THESE DRAWINGS ILLUSTRATE THE WORK TO BE DONE. THE ENGINEER IS NOT RESPONSIBLE FOR THE MEANS, METHODS, TECHNIQUES, SEQUENCES, AND PROCEDURES USED TO DO THE WORK, OR THE SAFETY ASPECTS OF CONSTRUCTION, AND NOTHING ON THESE DRAWINGS EXPRESSED OR IMPLIED CHANGES THIS CONDITION. CONTRACTOR SHALL DETERMINE ALL CONDITIONS AT THE SITE AND SHALL BE RESPONSIBLE FOR KNOWING HOW THEY AFFECT THE WORK. SUBMITTAL OF A BID TO PERFORM THIS WORK IS AN ACKNOWLEDGEMENT OF THE RESPONSIBILITIES, AND THAT THEY HAVE BEEN FULLY CONSIDERED IN PLANNING OF THE WORK, AND THE BID PRICE. NO CLAIMS FOR EXTRA CHARGES DUE TO THESE CONDITIONS WILL BE FORTHCOMING.

UNAUTHORIZED CHANGES:

IN THE EVENT THE CLIENT, THE CLIENT'S CONTRACTORS OR SUBCONTRACTORS, OR ANYONE FOR WHOM THE CLIENT IS LEGALLY LIABLE MAKES OR PERMITS TO BE MADE ANY CHANGES TO ANY REPORTS, PLANS, SPECIFICATIONS OR OTHER CONSTRUCTION DOCUMENTS PREPARED BY LRL ASSOCIATES LTD. (LRL) WITHOUT OBTAINING LRL'S PRIOR WRITTEN CONSENT, THE CLIENT SHALL ASSUME FULL RESPONSIBILITY FOR THE RESULTS OF SUCH CHANGES. THEREFORE THE CLIENT AGREES TO WAIVE ANY CLAIM AGAINST LRL AND TO RELEASE LRL FROM ANY LIABILITY ARISING DIRECTLY OR INDIRECTLY FROM SUCH UNAUTHORIZED CHANGES.

IN ADDITION, THE CLIENT AGREES, TO THE FULLEST EXTENT PERMITTED BY LAW, TO INDEMNIFY AND HOLD HARMLESS LRL FROM ANY DAMAGES, LIABILITIES OR COST, INCLUDING REASONABLE ATTORNEY'S FEES AND COST OF DEFENSE, ARISING FROM SUCH CHANGES.

GENERAL NOTES:

EXISTING SERVICES AND UTILITIES SHOWN ON THESE DRAWINGS ARE TAKEN FROM THE BEST AVAILABLE RECORDS, BUT MAY NOT BE COMPLETE OR TO DATE. CONTRACTOR SHALL VERIFY IN FIELD FOR LOCATION AND ELEVATION OF PIPES AND CHECK WITH THE UTILITY COMPANIES BEFORE DIGGING OR PERFORMING WORK.

CONTRACTOR IS ADVISED TO COLLECT INFORMATION ON SOIL CONDITIONS BEFORE START OF CONSTRUCTION.

THE ENGINEER WAIVES ANY AND ALL RESPONSIBILITY AND LIABILITY FOR PROBLEMS WHICH ARISE FROM FAILURE TO FOLLOW THESE PLANS, SPECIFICATIONS AND TO OBTAIN WRITTEN CONSENT FROM THE CONTRACTOR OR MODIFICATIONS TO LRL'S CONSTRUCTION DOCUMENTS WITHOUT THE PRIOR WRITTEN APPROVAL OF LRL AND THAT FURTHER REQUIRES THE CONTRACTOR TO INDEMNIFY BOTH LRL AND THE CLIENT FROM ANY LIABILITY OR COST ARISING FROM SUCH CHANGES MADE WITHOUT SUCH PROPER AUTHORIZATION.

CONTRACTOR TO VERIFY ALL DIMENSIONS AND NOTIFY THE ENGINEER OF ANY DISCREPANCIES BEFORE WORK COMMENCES. DO NOT SCALE DRAWINGS.

No.	REVISIONS	BY	DATE
07	ISSUED FOR APPROVAL	M.L.	11 OCT 2024
06	ISSUED FOR APPROVAL	M.L.	08 AUG 2024
05	ISSUED FOR APPROVAL	S.V.	30 JUL 2024
04	ISSUED FOR APPROVAL	M.L.	28 JUN 2024
03	ISSUED FOR APPROVAL	M.L.	29 JAN 2024
02	ISSUED FOR APPROVAL	M.L.	25 OCT 2023
01	ISSUED FOR COORDINATION	M.L.	06 OCT 2023

NOT AUTHENTIC UNLESS SIGNED AND DATED

LRL
ENGINEERING | INGENIERIE
5430 Canotek Road | Ottawa, ON, K1J 9G2
www.lrl.ca | (613) 842-3434

CLIENT
TRIM WORKS DEVELOPMENT LTD

DESIGNED BY: M.L. DRAWN BY: M.L. APPROVED BY: M.B.

PROJECT
**PLAZA TRIM ROAD DEVELOPMENT
1280 TRIM RD,
OTTAWA, ON**

DRAWING TITLE
**PRE-DEVELOPMENT
WATERSHED PLAN**

PROJECT NO. 230202
DATE APRIL 2023

C701

LEGEND:

- EXISTING PROPERTY LINE TO REMAIN
- PROPOSED CURB
- PROPOSED DEPRESSED CURB
- PROPOSED TERRACING (3:1 MIN.)
- PROPOSED SILT FENCE AS PER OPSD 219.110
- PROPOSED DOOR ENTRANCE/EXIT
- PROPOSED GRASS AREA (100mm TOP SOIL & SOD)
- PROPOSED CONCRETE FEATURES/SLAB
- PROPOSED HEAVY DUTY ASPHALT
- PROPOSED LIGHT DUTY ASPHALT
- *50.00 PROPOSED ELEVATION
- *50.00HP PROPOSED HIGH POINT ELEVATION
- *50.00BC PROPOSED BOTTOM OF CURB / ASPHALT ELEVATION
- *50.00TC PROPOSED TOP OF CURB ELEVATION
- *50.00BW PROPOSED EXPOSED BOTTOM OF RETAINING WALL
- *50.00TW PROPOSED TOP OF RETAINING WALL
- *50.00EX MATCH INTO EXISTING ELEVATION
- *70.19 PROPOSED OVERLAND MAJOR FLOW ROUTE
- STM PROPOSED STORM SEWER
- SAN PROPOSED SANITARY SEWER
- WTR PROPOSED WATERMAIN
- STM EXISTING STORM SEWER
- SAN EXISTING SANITARY SEWER
- WTR EXISTING WATERMAIN
- EXISTING MANHOLE
- EXISTING CATCHBASIN
- PROPOSED CATCHBASIN-MANHOLE/CATCHBASIN
- PROPOSED MANHOLE
- PROPOSED CURB STOP
- PROPOSED PIPE INSULATION
- PROPOSED 100 YEAR HIGH WATER LEVEL
- STORM WATERSHED EXTENT
- WS-XX WATERSHED NAME
- R RUNOFF COEFFICIENT
- A AREA IN HECTARES

USE AND INTERPRETATION OF DRAWINGS

GENERAL CONDITIONS OF THE CONTRACT FOR CONSTRUCTION ARE PART OF THE CONTRACT DOCUMENTS AND DESCRIBE USE AND INTENT OF THE DRAWING. THE CONTRACTOR SHALL BE RESPONSIBLE FOR OBTAINING ALL NECESSARY PERMITS AND APPROVALS FROM THE LOCAL AUTHORITY. THE CONTRACTOR SHALL BE RESPONSIBLE FOR OBTAINING ALL NECESSARY PERMITS AND APPROVALS FROM THE LOCAL AUTHORITY. THE CONTRACTOR SHALL BE RESPONSIBLE FOR OBTAINING ALL NECESSARY PERMITS AND APPROVALS FROM THE LOCAL AUTHORITY.

BY USE OF THE DRAWINGS FOR CONSTRUCTION OF THE PROJECT, THE OWNER AGREES TO WAIVE ANY CLAIM AGAINST LRL AND TO RELEASE LRL FROM ANY LIABILITY ARISING DIRECTLY OR INDIRECTLY FROM SUCH UNAUTHORIZED CHANGES.

IN ADDITION, THE CLIENT AGREES TO INCLUDE IN ANY CONTRACTS FOR CONSTRUCTION APPROPRIATE LANGUAGE THAT PROHIBITS THE CONTRACTOR OR ANY SUBCONTRACTORS OF ANY TIER FROM MAKING ANY CHANGES OR MODIFICATIONS TO THE CONTRACT DOCUMENTS WITHOUT THE PRIOR WRITTEN APPROVAL OF LRL AND THAT FURTHER REQUIRES THE CONTRACTOR TO INDEMNIFY BOTH LRL AND THE CLIENT FROM ANY LIABILITY OR COST ARISING FROM SUCH CHANGES MADE WITHOUT SUCH PROPER AUTHORIZATION.

GENERAL NOTES:

EXISTING SERVICES AND UTILITIES SHOWN ON THESE DRAWINGS ARE TAKEN FROM THE BEST AVAILABLE RECORDS, BUT MAY NOT BE COMPLETE OR TO DATE. CONTRACTOR SHALL VERIFY IN FIELD FOR LOCATION AND DEPTH OF PIPES AND CHECK WITH THE UTILITY COMPANIES BEFORE DIGGING OR PERFORMING WORK.

CONTRACTOR IS ADVISED TO COLLECT INFORMATION ON SOIL CONDITIONS BEFORE START OF CONSTRUCTION.

THE ENGINEER WAIVES ANY AND ALL RESPONSIBILITY AND LIABILITY FOR PROBLEMS WHICH ARISE FROM FAILURE TO FOLLOW THESE PLANS, SPECIFICATIONS AND TO ANY REPORTS, PLANS, SPECIFICATIONS OR FOR PROBLEMS WHICH ARISE FROM OTHERS' FAILURE TO OBTAIN AND/OR FOLLOW THE ENGINEER'S GUIDANCE WITH RESPECT TO ANY ERRORS, OMISSIONS, INCONSISTENCIES, AMBIGUITIES OR CONFLICTS WHICH ARE ALLEGED.

CONTRACTOR TO VERIFY ALL DIMENSIONS AND NOTIFY THE ENGINEER OF ANY DISCREPANCIES BEFORE WORK COMMENCES. DO NOT SCALE DRAWINGS.

5m 0 5 10m
SCALE: 1:250

SUBJECT FOR APPROVAL

No.	REVISIONS	BY	DATE
07	ISSUED FOR APPROVAL	M.L.	11 OCT 2024
06	ISSUED FOR APPROVAL	M.L.	08 AUG 2024
05	ISSUED FOR APPROVAL	S.V.	30 JUL 2024
04	ISSUED FOR APPROVAL	M.L.	28 JUN 2024
03	ISSUED FOR APPROVAL	M.L.	29 JAN 2024
02	ISSUED FOR APPROVAL	M.L.	25 OCT 2023
01	ISSUED FOR COORDINATION	M.L.	06 OCT 2023



NOT AUTHENTIC UNLESS SIGNED AND DATED

LRL
ENGINEERING | INGÉNIERIE
5430 Canotek Road | Ottawa, ON, K1J 9G2
www.lrl.ca | (613) 842-3434

CLIENT
TRIM WORKS DEVELOPMENT LTD

DESIGNED BY: M.L. DRAWN BY: M.L. APPROVED BY: M.B.

PROJECT
**PLAZA TRIM ROAD DEVELOPMENT
1280 TRIM RD,
OTTAWA, ON**

DRAWING TITLE
**POST-DEVELOPMENT
WATERSHED PLAN**

PROJECT NO. 230202
DATE APRIL 2023

C702

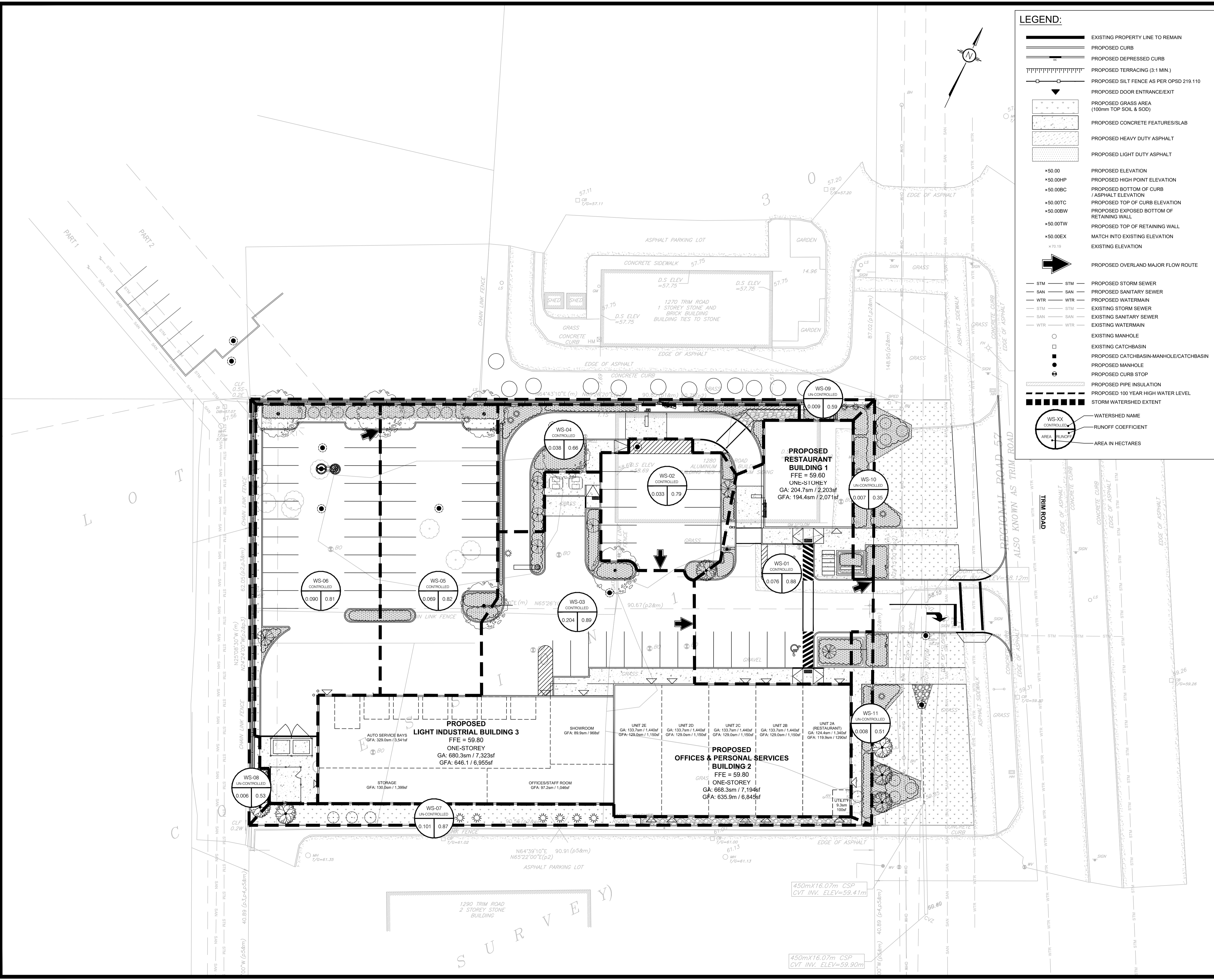

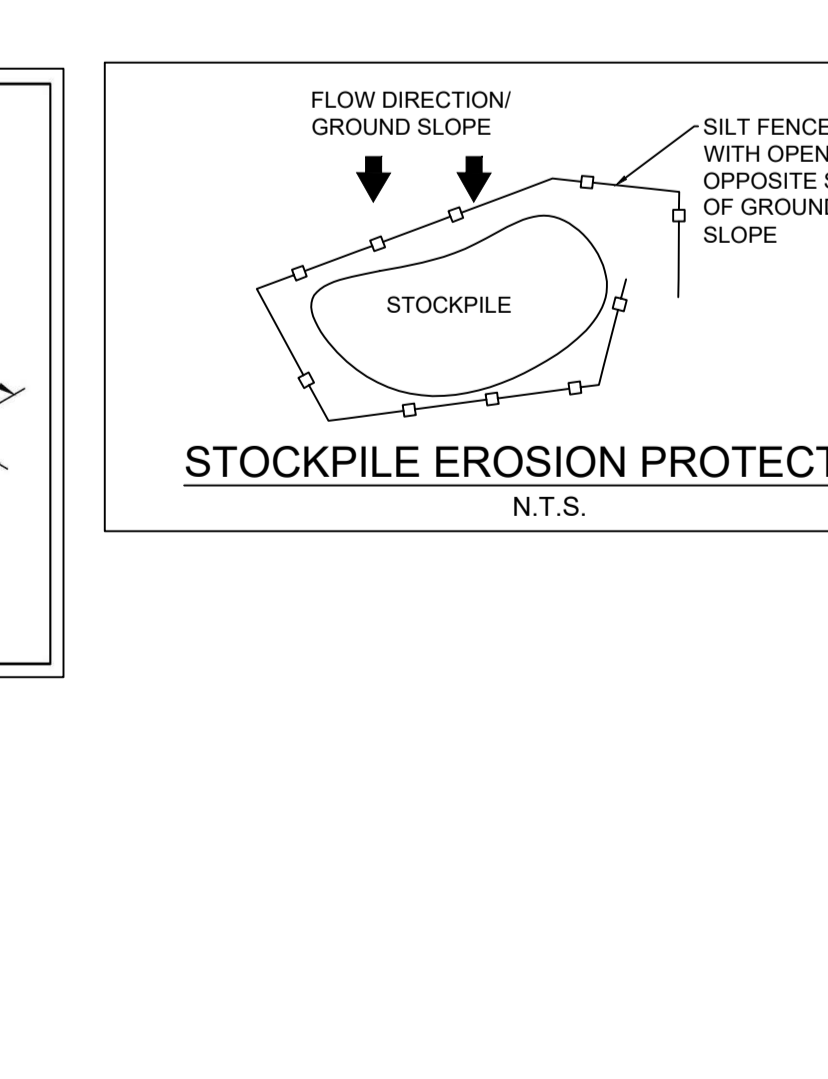
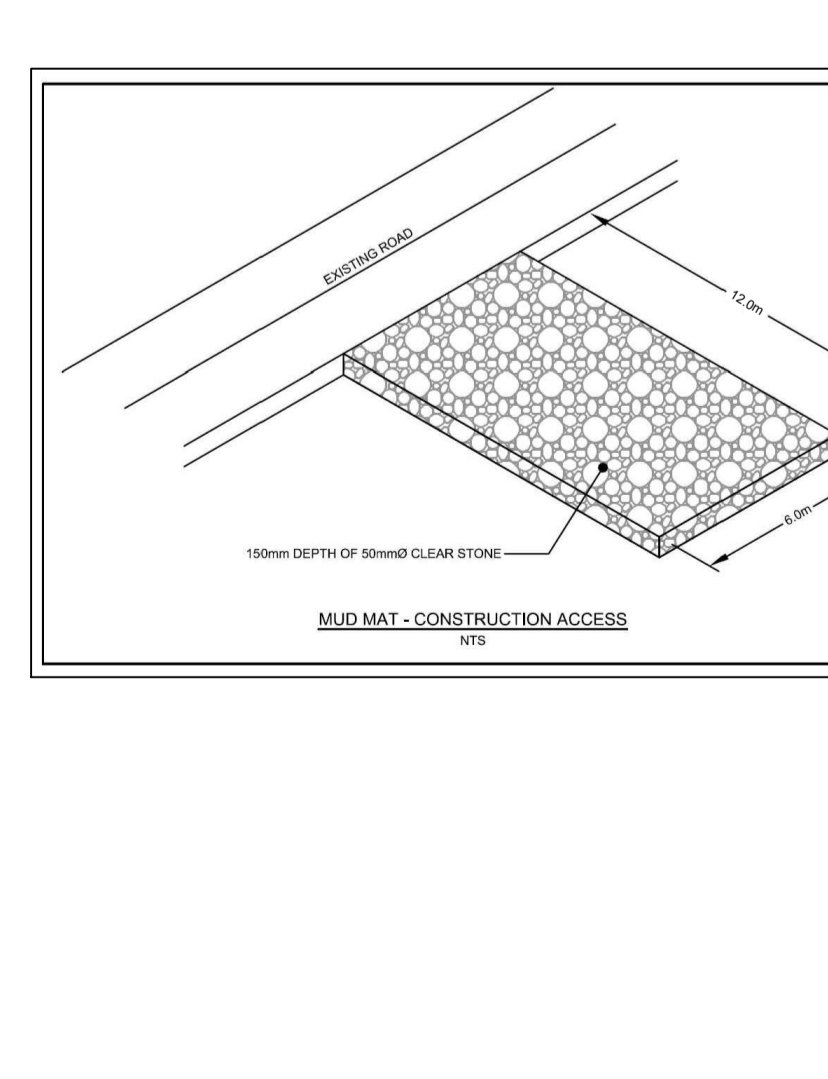
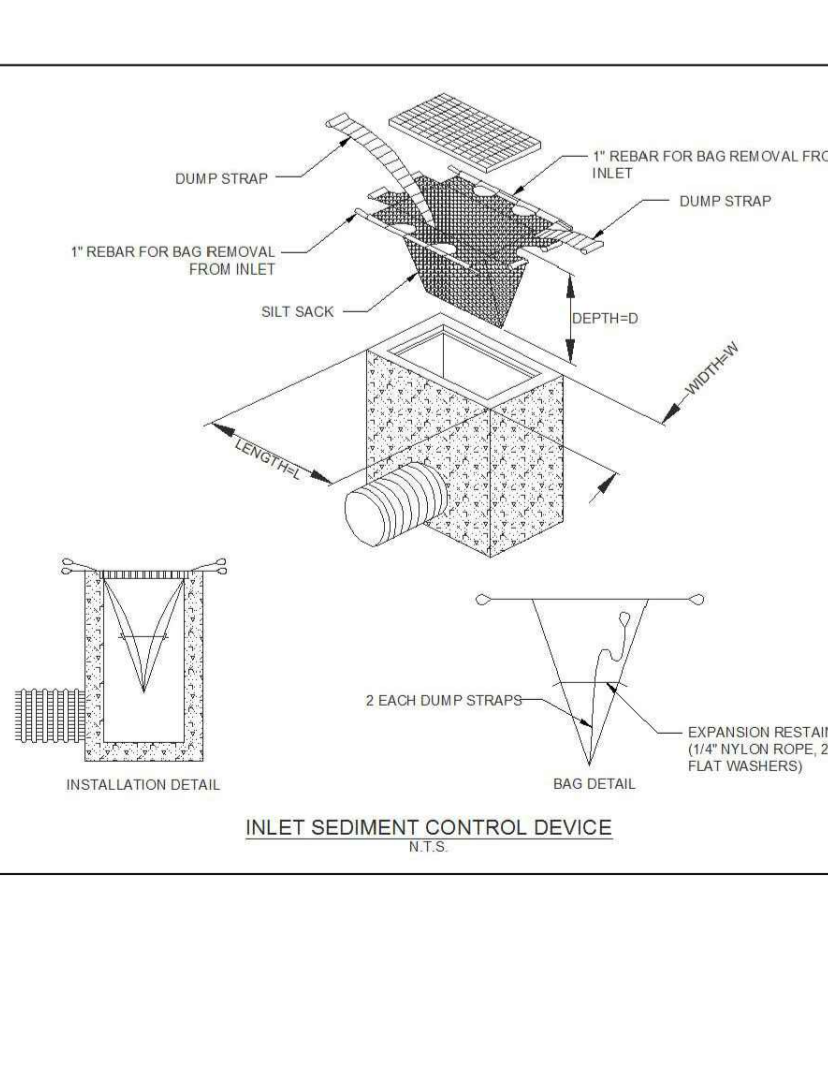
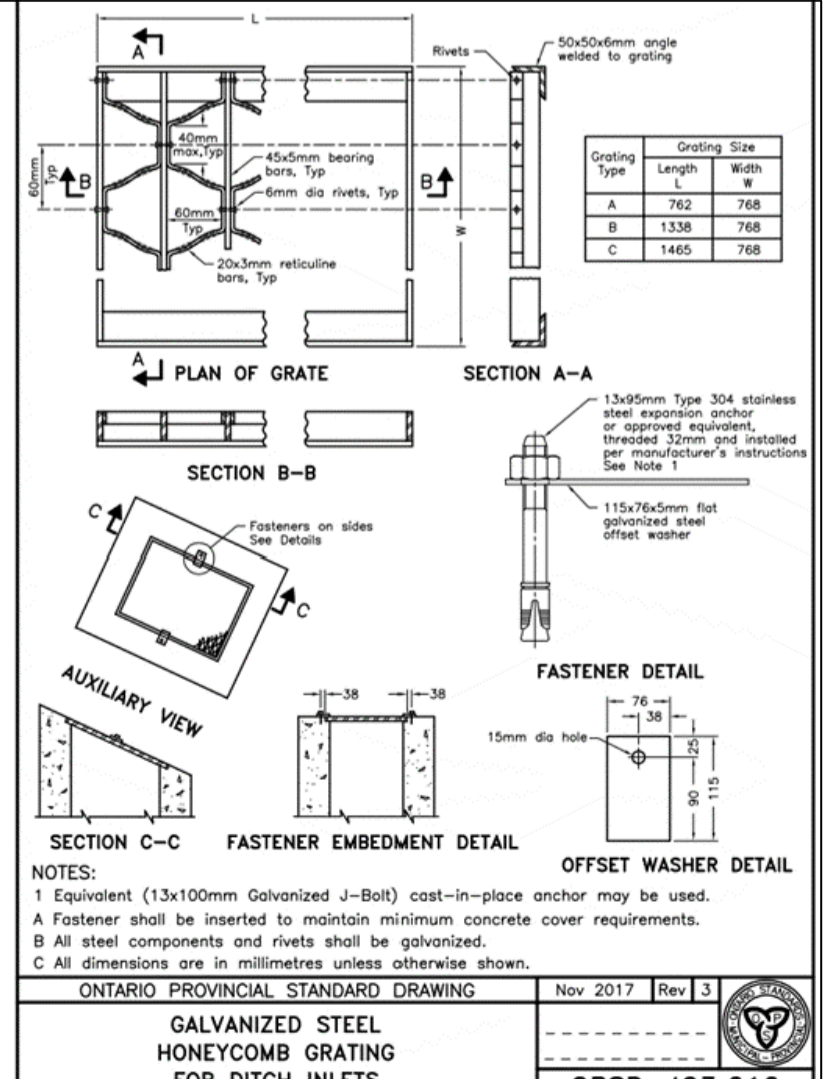
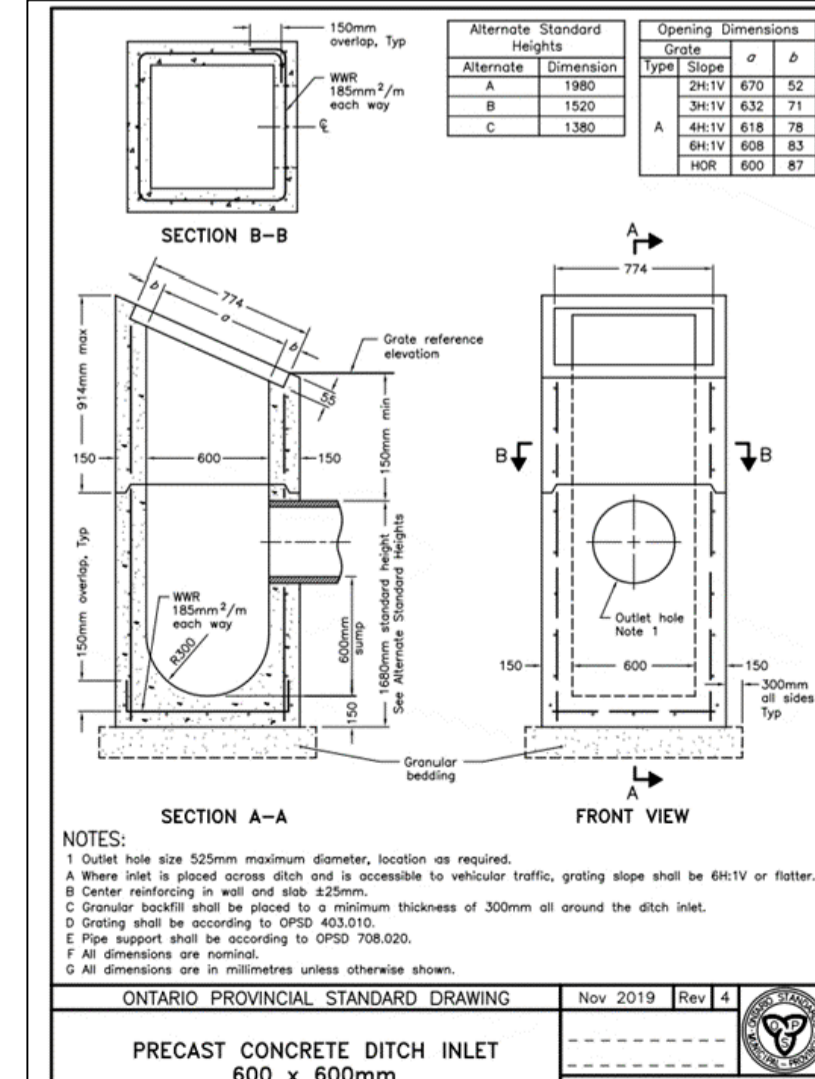
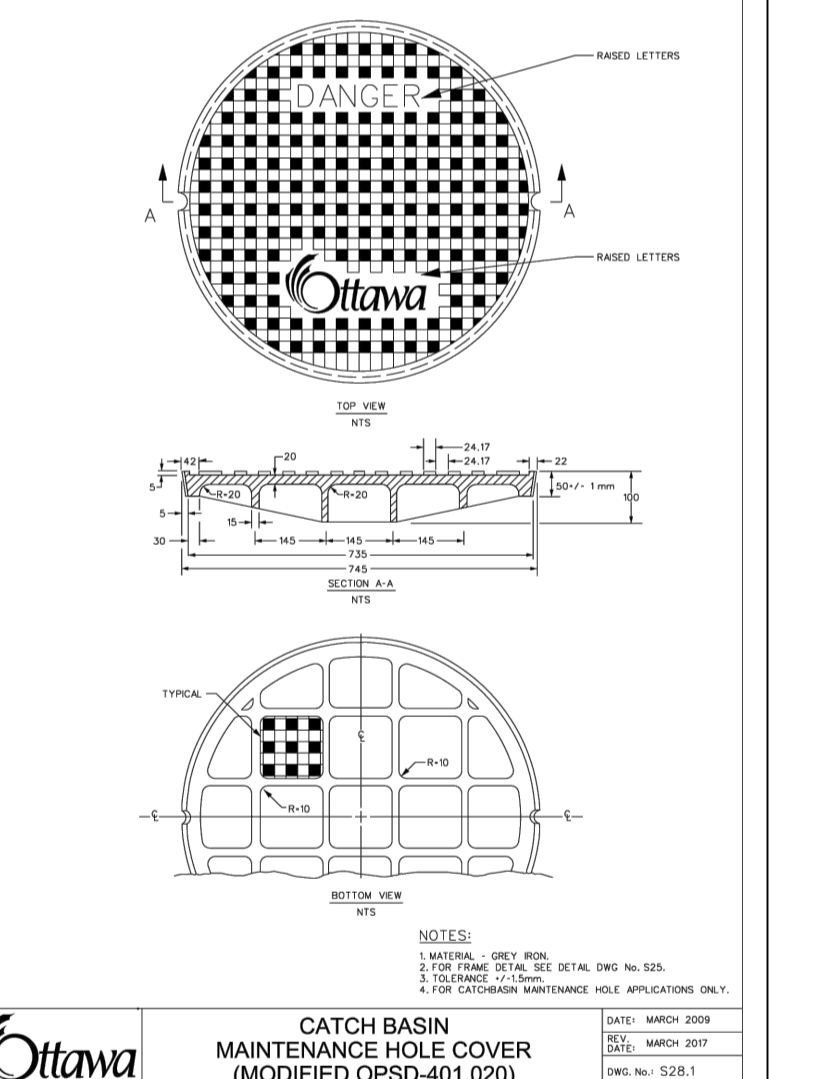
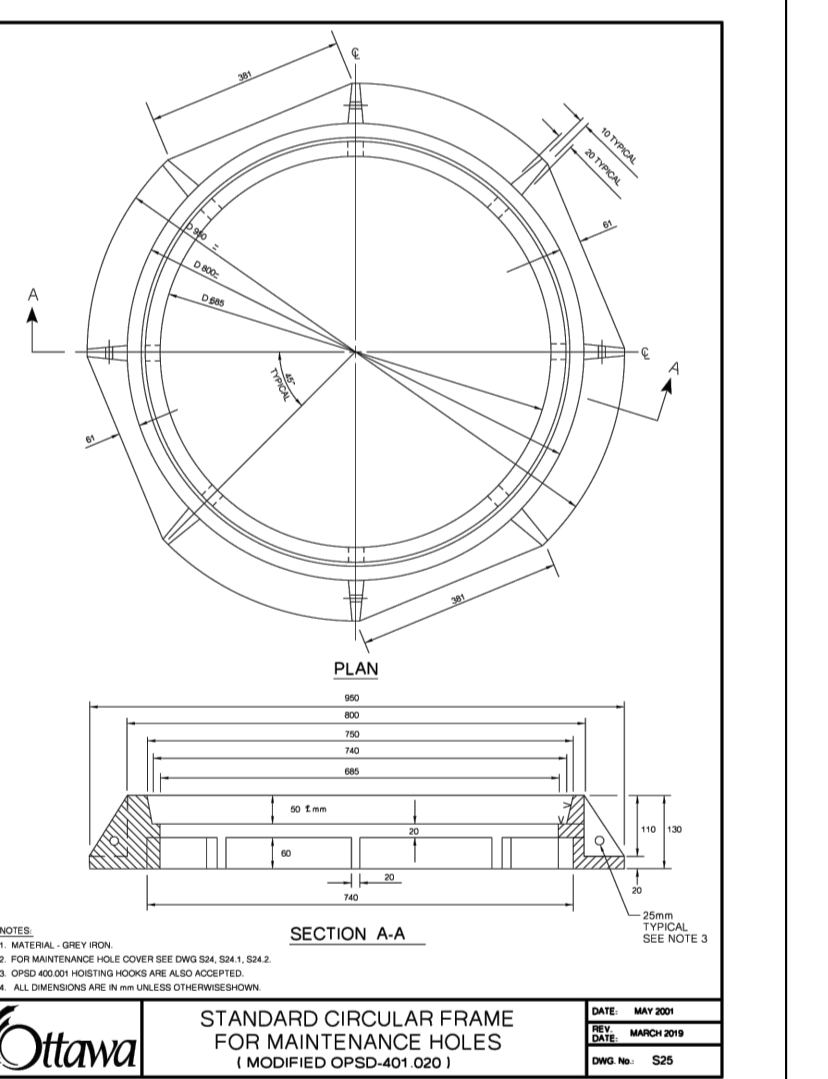
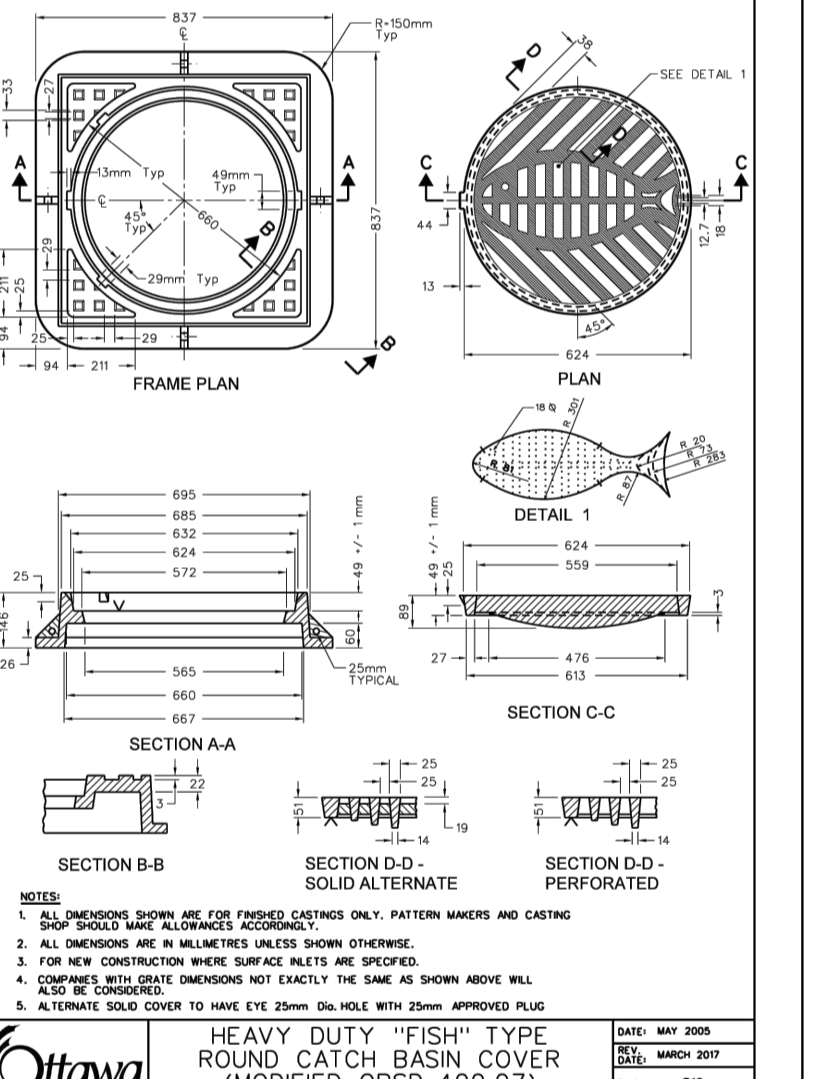
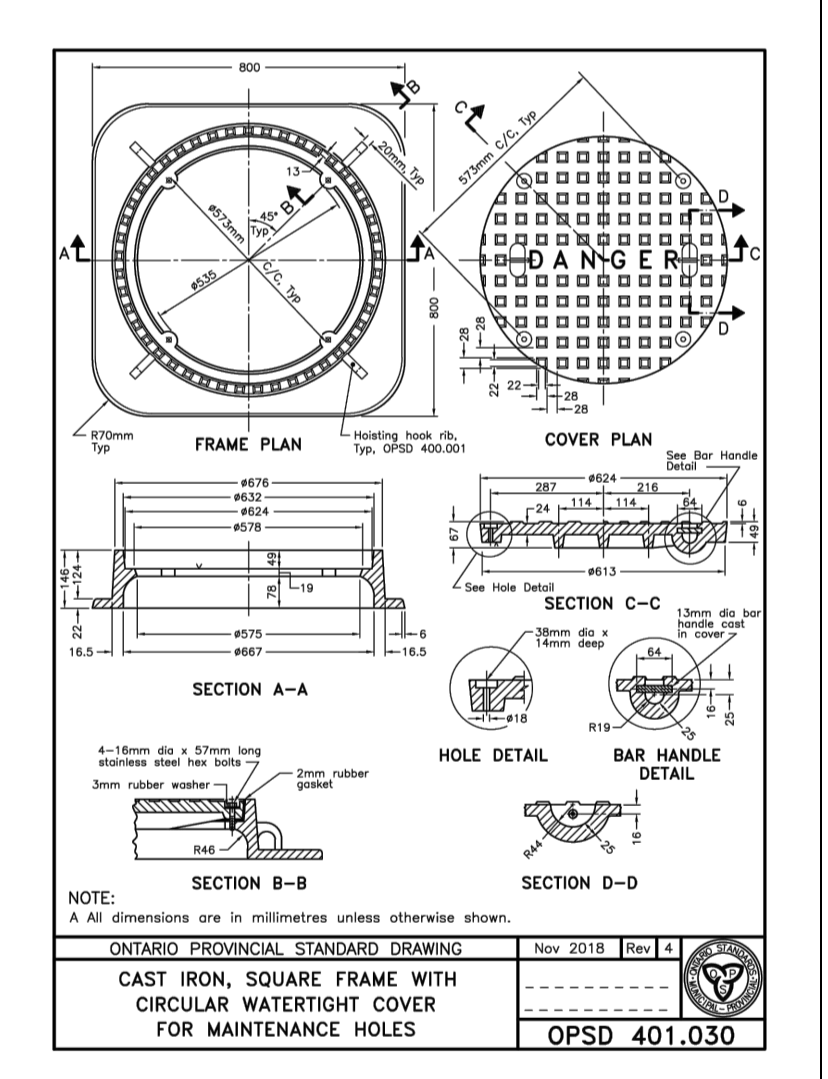
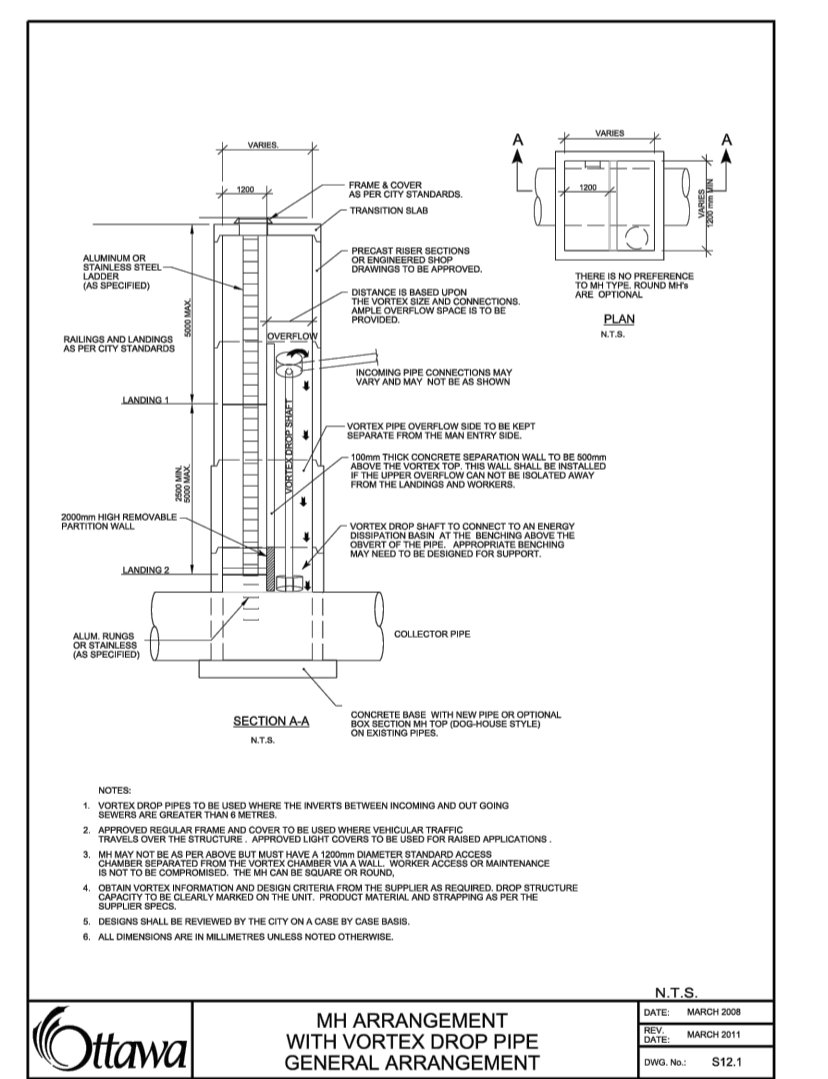
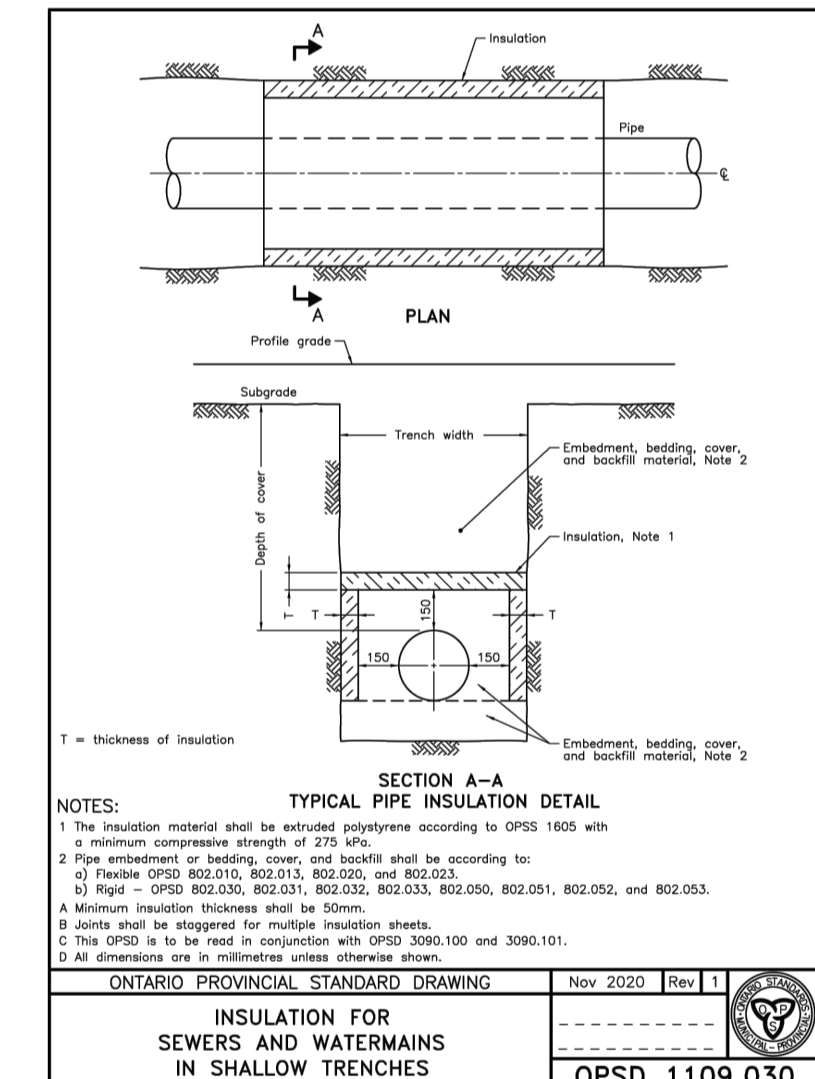
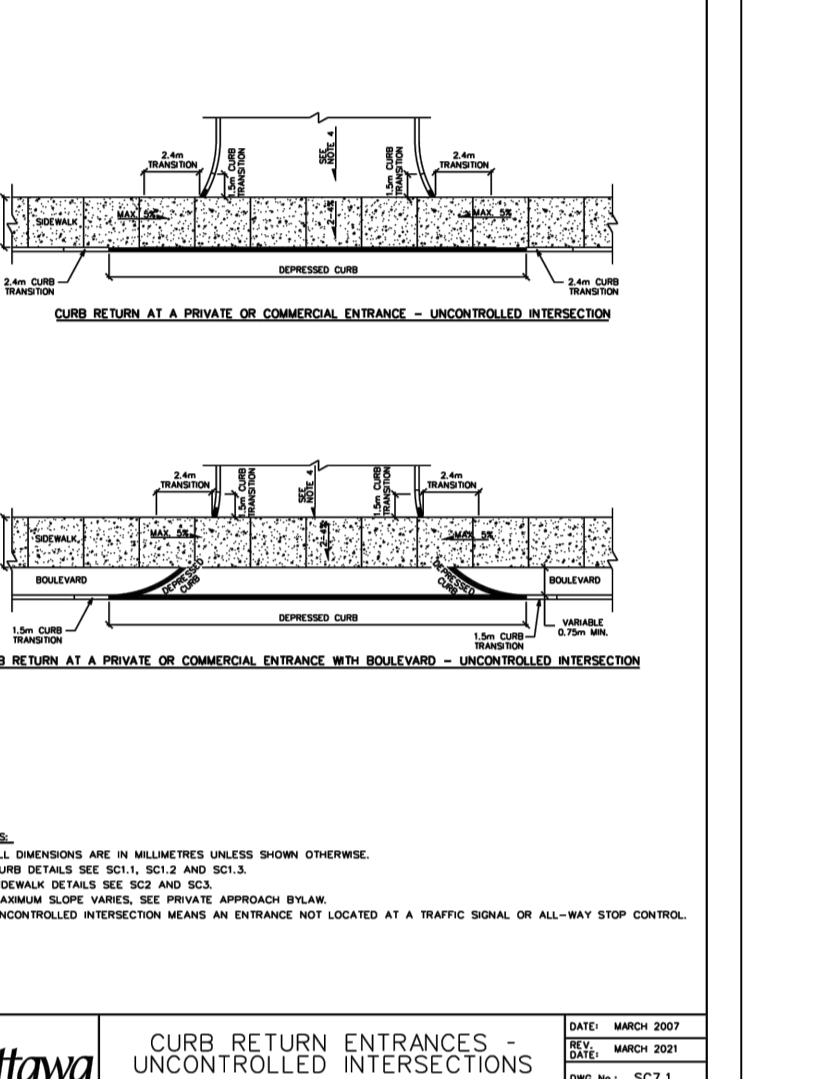
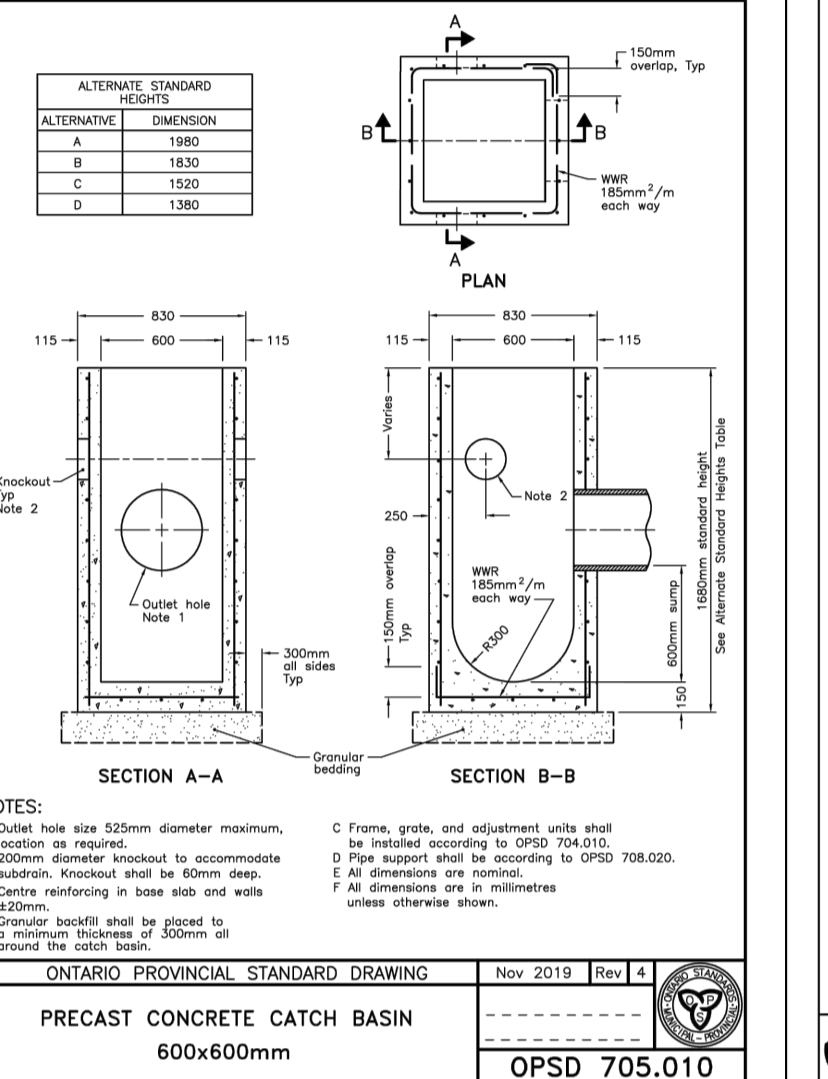
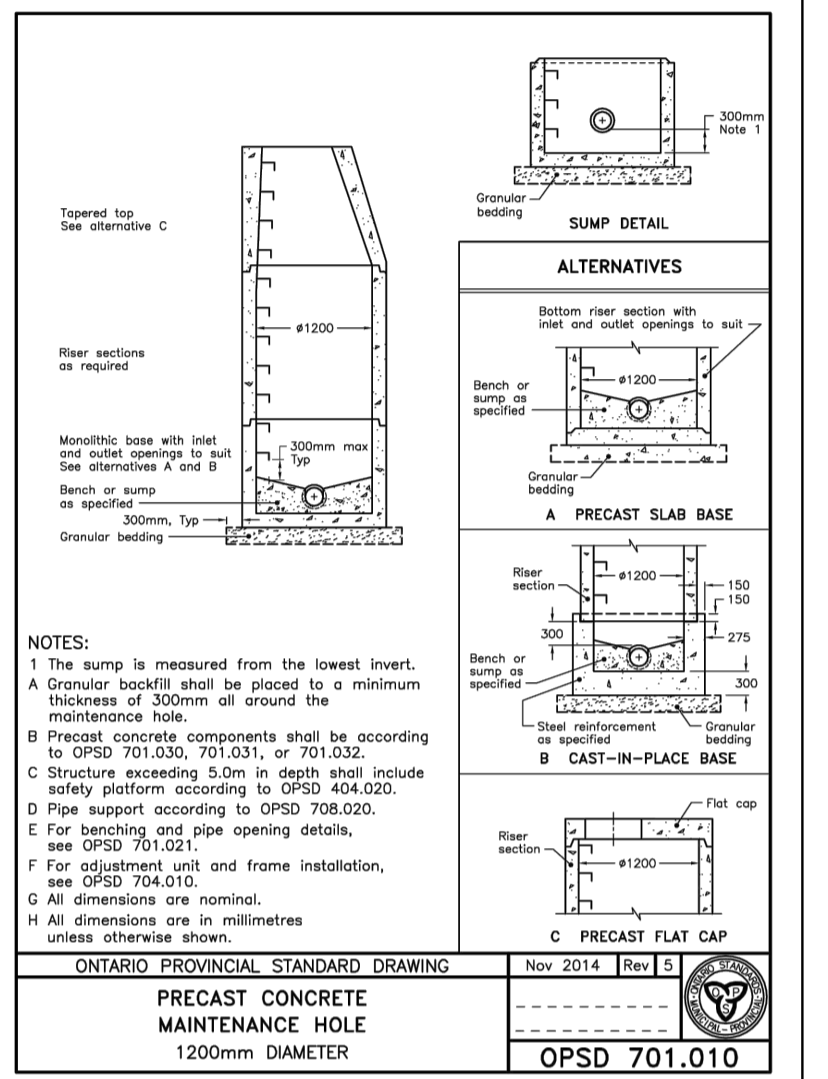
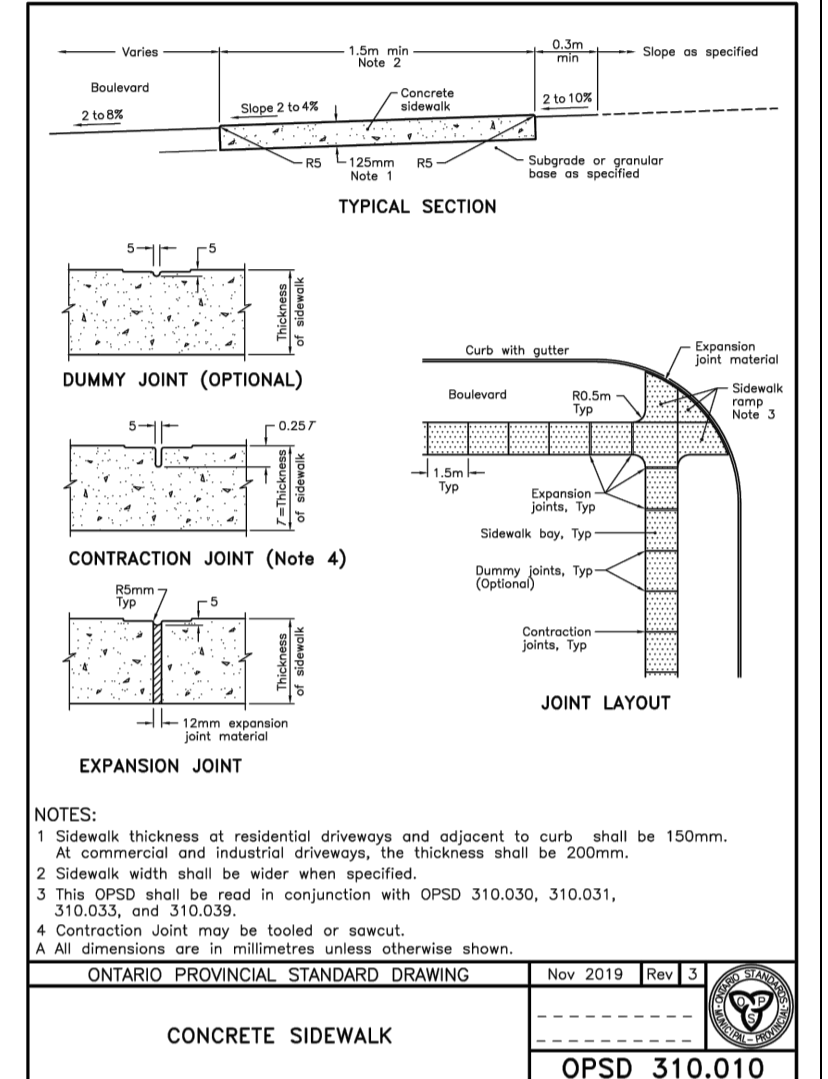
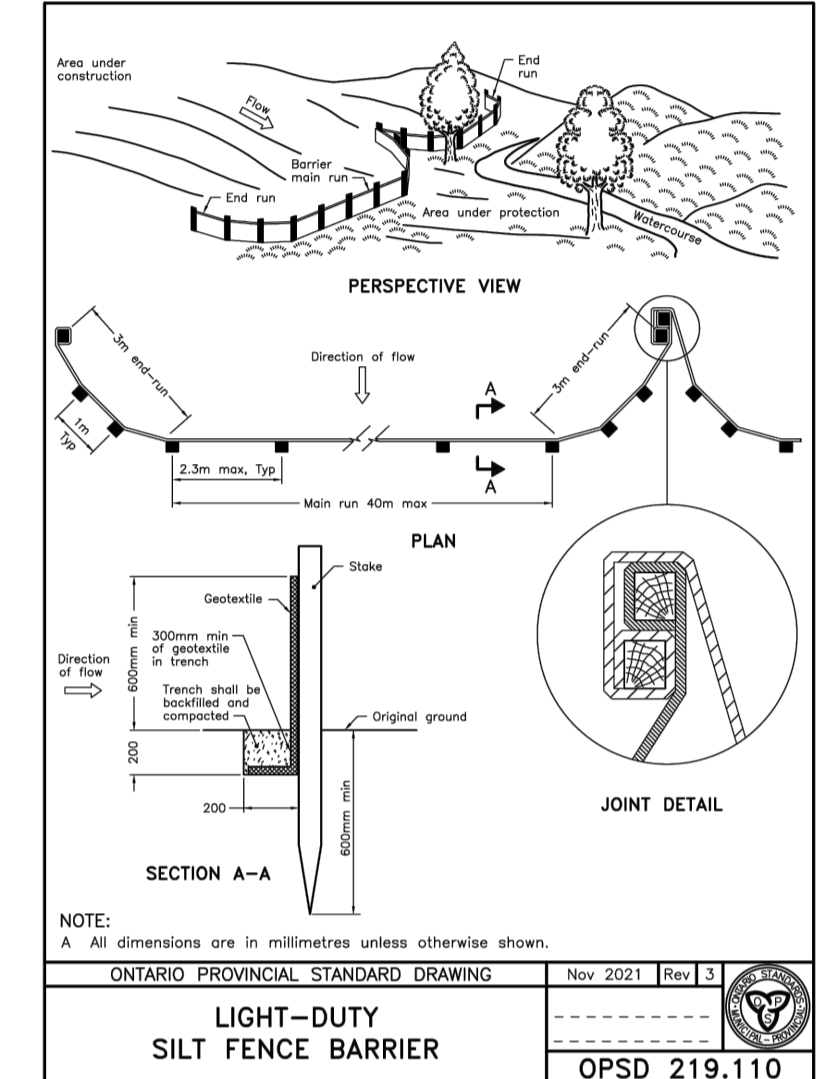
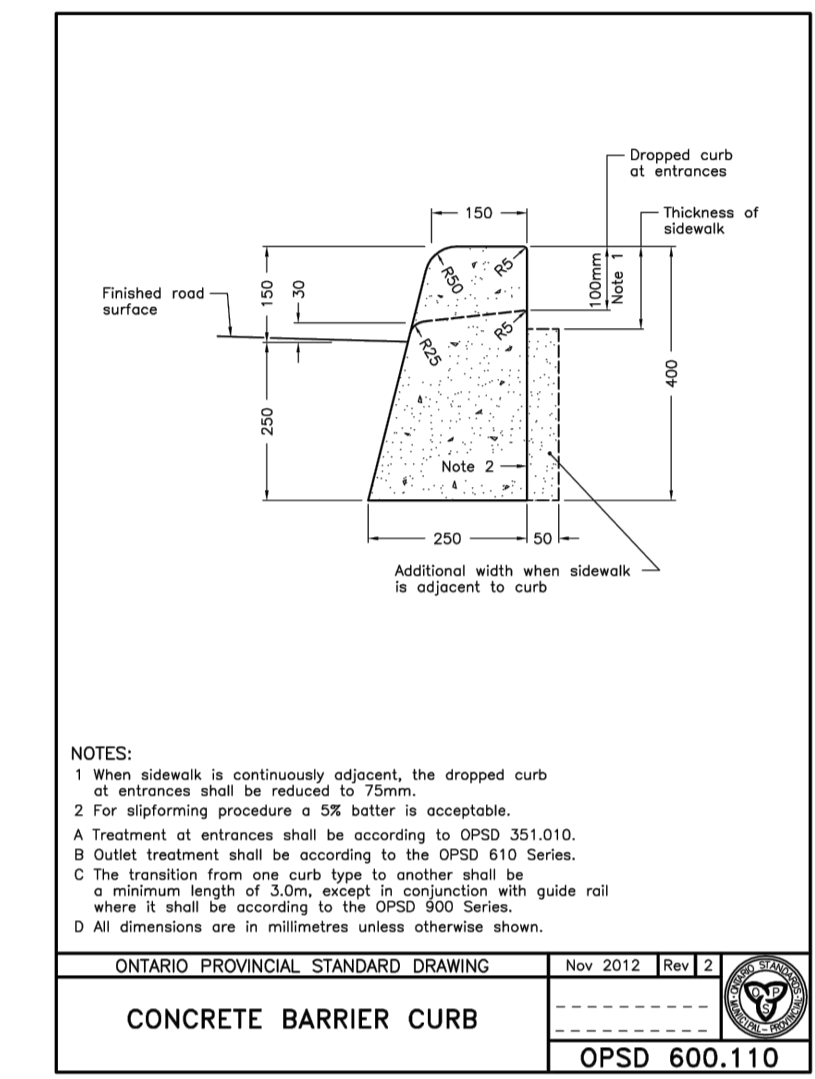
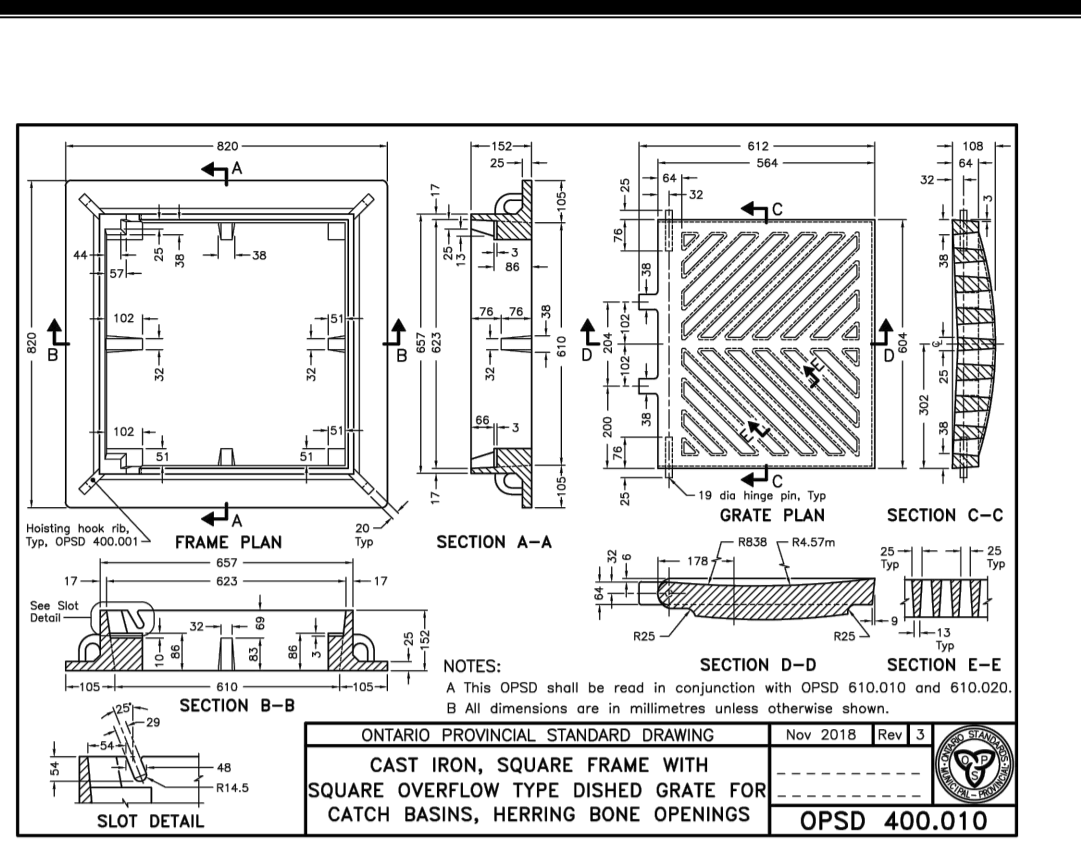
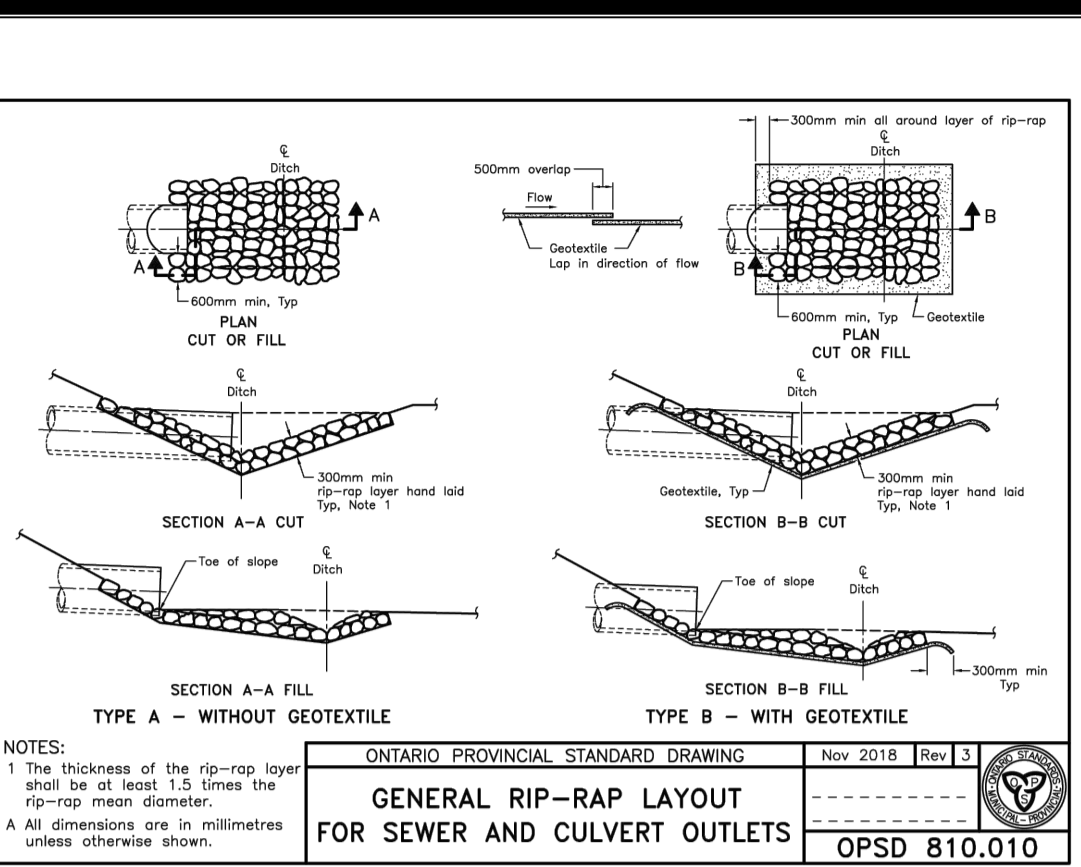
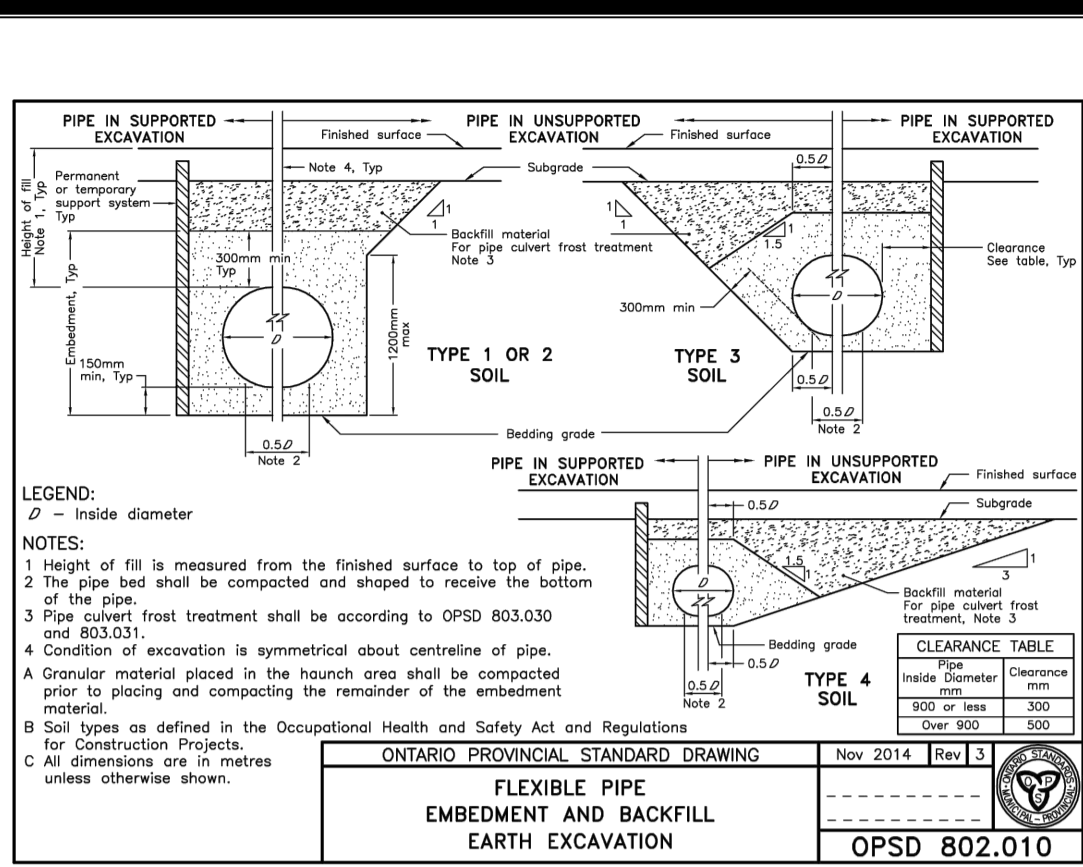
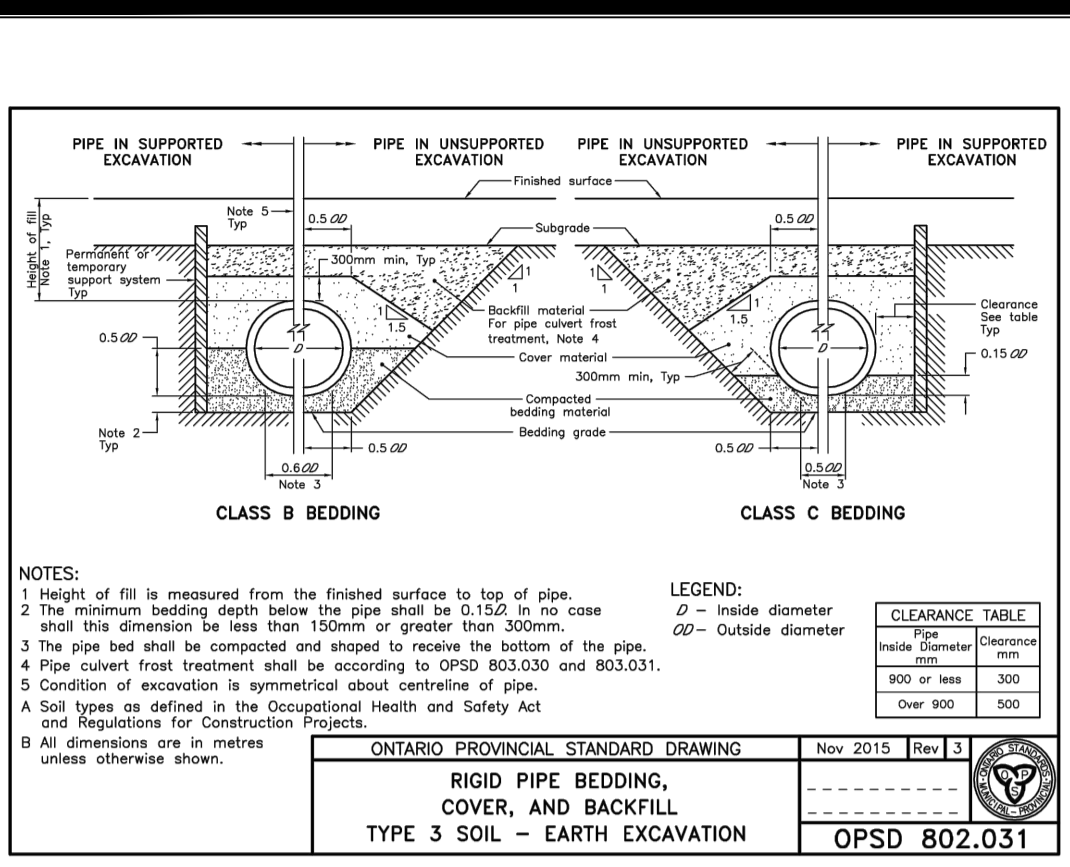

GENERAL CONDITIONS OF THE CONTRACT FOR CONSTRUCTION ARE PART OF THE CONTRACT DOCUMENTS AND DESCRIBE THE SCOPE AND INTENT OF THE DRAWINGS. THE CONTRACTOR SHALL BE RESPONSIBLE FOR OBTAINING ALL NECESSARY PERMITS AND APPROVALS FROM THE APPROPRIATE AGENCIES AND AUTHORITIES. THE CONTRACTOR SHALL BE RESPONSIBLE FOR OBTAINING ALL NECESSARY PERMITS AND APPROVALS FROM THE APPROPRIATE AGENCIES AND AUTHORITIES. THE CONTRACTOR SHALL BE RESPONSIBLE FOR OBTAINING ALL NECESSARY PERMITS AND APPROVALS FROM THE APPROPRIATE AGENCIES AND AUTHORITIES.

GENERAL NOTES:
 1. ALL DIMENSIONS ARE IN MILLIMETRES UNLESS SHOWN OTHERWISE.
 2. CURB DETAILS SEE OPSD 600.110.
 3. SIDEWALK DETAILS SEE OPSD 310.010.
 4. UNCONTROLLED INTERSECTIONS ARE AN ENTRANCE NOT LOCATED AT A TRAFFIC SIGNAL, ALL-WAY STOP CONTROL, OR OTHER CONTROLLED INTERSECTION.
 5. UNCONTROLLED INTERSECTIONS ARE AN ENTRANCE NOT LOCATED AT A TRAFFIC SIGNAL, ALL-WAY STOP CONTROL, OR OTHER CONTROLLED INTERSECTION.

SUBJECT FOR APPROVAL

No.	REVISIONS	BY	DATE
07	ISSUED FOR APPROVAL	M.L.	11 OCT 2024
06	ISSUED FOR APPROVAL	M.L.	08 AUG 2024
05	ISSUED FOR APPROVAL	S.V.	30 JUL 2024
04	ISSUED FOR APPROVAL	M.L.	28 JUN 2024
03	ISSUED FOR APPROVAL	M.L.	29 JAN 2024
02	ISSUED FOR APPROVAL	M.L.	25 OCT 2023
01	ISSUED FOR COORDINATION	M.L.	06 OCT 2023

NOT AUTHENTIC UNLESS SIGNED AND DATED

Licensed Professional Engineer
M. BASNET
 100501996
 2024/10/11
 PROVINCE OF ONTARIO

LRL
 ENGINEERING | INGENIERIE
 5430 Canotek Road | Ottawa, ON, K1J 9G2
 www.lrl.ca | (613) 842-3434

CLIENT
TRIM WORKS DEVELOPMENT LTD

DESIGNED BY: M.L. **DRAWN BY:** M.L. **APPROVED BY:** M.B.

PROJECT
PLAZA TRIM ROAD DEVELOPMENT
 1280 TRIM RD,
 OTTAWA, ON

DRAWING TITLE
CONSTRUCTION DETAIL PLAN

PROJECT NO. 230202
DATE APRIL 2023

C901

APPENDIX F
Survey/As Built

**PLAN OF SURVEY
WITH TOPOGRAPHY
OF PART OF
LOT 30
CONCESSION 1 (OLD SURVEY)
GEOGRAPHIC TOWNSHIP
OF CUMBERLAND
CITY OF OTTAWA**

McINTOSH PERRY SURVEYING INC.

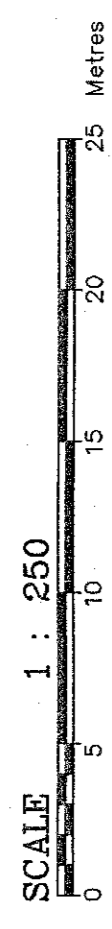

METRIC :
DISTANCES SHOWN ON THIS PLAN ARE IN METRES AND CAN BE CONVERTED TO FEET BY DIVIDING BY 0.3048.

SURVEYOR'S CERTIFICATE

I CERTIFY THAT:
1. THIS SURVEY AND PLAN ARE CORRECT AND IN ACCORDANCE WITH THE SURVEY ACT AND THE LAND TITLES ACT AND THE REGULATIONS MADE UNDER THEM.
2. THE SURVEY WAS COMPLETED ON THE 16 DAY OF APRIL 2021.

DATE MAY 7, 2021
JOHN GAUTHIER
ONTARIO LAND SURVEYOR

LEGEND AND NOTES

- MONUMENT PLANTED
- MONUMENT SET
- SSB SHORT STANDARD IRON BAR
- IB IRON BAR
- M MEASURED
- P1 DENOTES PLAN 508-5994
- P2 DENOTES PLAN 508-7108
- P3 DENOTES PLAN 508-386
- P4 DENOTES PLAN 508-386
- P5 DENOTES PLAN 508-386
- (400) DENOTES SURVEY BY ANNIS, O'SULLIVAN, VOLLEBERG LTD.
- (671) DENOTES DATED MARCH 20, 2018, O.S. VOLLEBERG LTD.
- (1481) DENOTES FRED H. GOOCH, O.L.S.
- DENOTES DENIS DUTRISAC INC.
- MH MANHOLE
- OB DENOTES OBSTRUCTION
- DI DENOTES DITCH
- DIH DENOTES DITCH INLET
- DIHB DENOTES DITCH INLET BOTTOM
- FIH DENOTES FIRE HYDRANT
- AN DENOTES ANCHOR
- CH DENOTES CHAIN
- CHW DENOTES CHAIN WIRE
- B DENOTES BOLLARD
- G DENOTES GAS METER
- GM DENOTES GAS METER
- HP DENOTES HYDRO POLE
- HPH DENOTES HYDRO POLE HEAD
- HM DENOTES HYDRO METER
- HT DENOTES HYDRO TAP
- CVT DENOTES CULVERT
- INV DENOTES INVERT
- CSP DENOTES CORRUGATED STEEL PIPE
- W DENOTES WATER VALVE
- WP DENOTES WATER PIPING
- LS DENOTES LIGHT STANDARD
- BO DENOTES BOREHOLE
- DS DENOTES DOOR SILL
- LF DENOTES LIFT
- CF DENOTES CONCRETE FENCE
- CT DENOTES CONIFEROUS TREE
- DT DENOTES DECIDUOUS TREE

BENCHMARKS

ELEVATIONS ARE GEODETIC (CGD-2678) DERIVED FROM GNSS OBSERVATIONS ON A NETWORK OF BENCHMARKS. THE BENCHMARKS ARE PUBLISHED OBSERVATIONS ON CANADIAN BENCHMARK 018530186, HAVING A PUBLISHED ELEVATION OF 88.45m.
TEMPORARY SITE BENCHMARK IS THE TOP OF THE SPINDLE ON A FIRE HYDRANT, SHOWN ON PLAN, HAVING AN ELEVATION OF 59.12m

DISTANCES

DISTANCES SHOWN ON THIS PLAN ARE GEOMETRIC DISTANCES AND CAN BE CONVERTED TO GRID DISTANCES BY MULTIPLYING BY A COMBINED SCALE FACTOR OF 0.999974.

BEARINGS

BEARINGS SHOWN ON THIS PLAN ARE MATRICE BEARINGS, DERIVED FROM GNSS OBSERVATIONS ON A NETWORK OF BENCHMARKS. THE BENCHMARKS ARE PUBLISHED OBSERVATIONS ON CANADIAN BENCHMARK 018530186, HAVING A PUBLISHED MERIDIAN OF MATRICE ZONE 9, (7° 50' WEST LONGITUDE) MAGNUS (ORIGINAL) OBSERVED REFERENCE POINTS (ORP) DERIVED FROM GPS WITH ZONE 9 MAGNUS (ORIGINAL).
COORDINATES TO UTM ACCURACY PER SEC. 14 (2) OF O. REG. 216/10

POINT ID	NORTHING	EASTING
ORP 'A'	5039352.59	384528.80
ORP 'B'	5039563.52	384530.64

THE LOCATION AND CONSTRUCTION OF UNDERGROUND SERVICES AND UTILITIES WERE NOT INCLUDED IN THIS SURVEY. IT IS THE RESPONSIBILITY OF THE CONTRACTOR TO VERIFY THE LOCATION AND DEPTH OF UNDERGROUND SERVICES AT THE SITE PRIOR TO CONSTRUCTION.
MPSI DOES NOT GUARANTEE THE ELEVATIONS OF THE NOTED BENCHMARKS. THE CONTRACTOR IS RESPONSIBLE FOR THE RESPONSIBILITY OF CONFIRMING THE LOCATIONS AND ELEVATION FOR ALIGNMENT OF EACH AND ALL PARTS OF WORK.

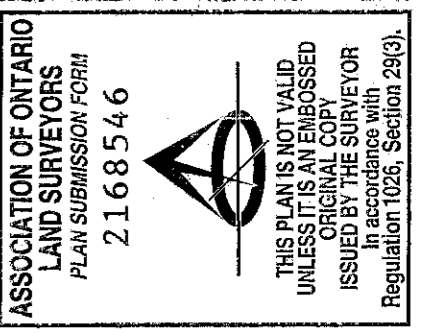

JOB No. 22-0136 DRAWING: 22-0136 P05 with Topo
THIS PLAN WAS PREPARED FOR: MPCE
McINTOSH PERRY SURVEYING INC.
2340 Drummond St., 5th Fl., R.R. #7, Perth, ON K7H 3G9
Tel: 613-267-7900 Fax: 613-267-7952
www.mcintoshperry.com
EXAMINED: JS CAD: MP

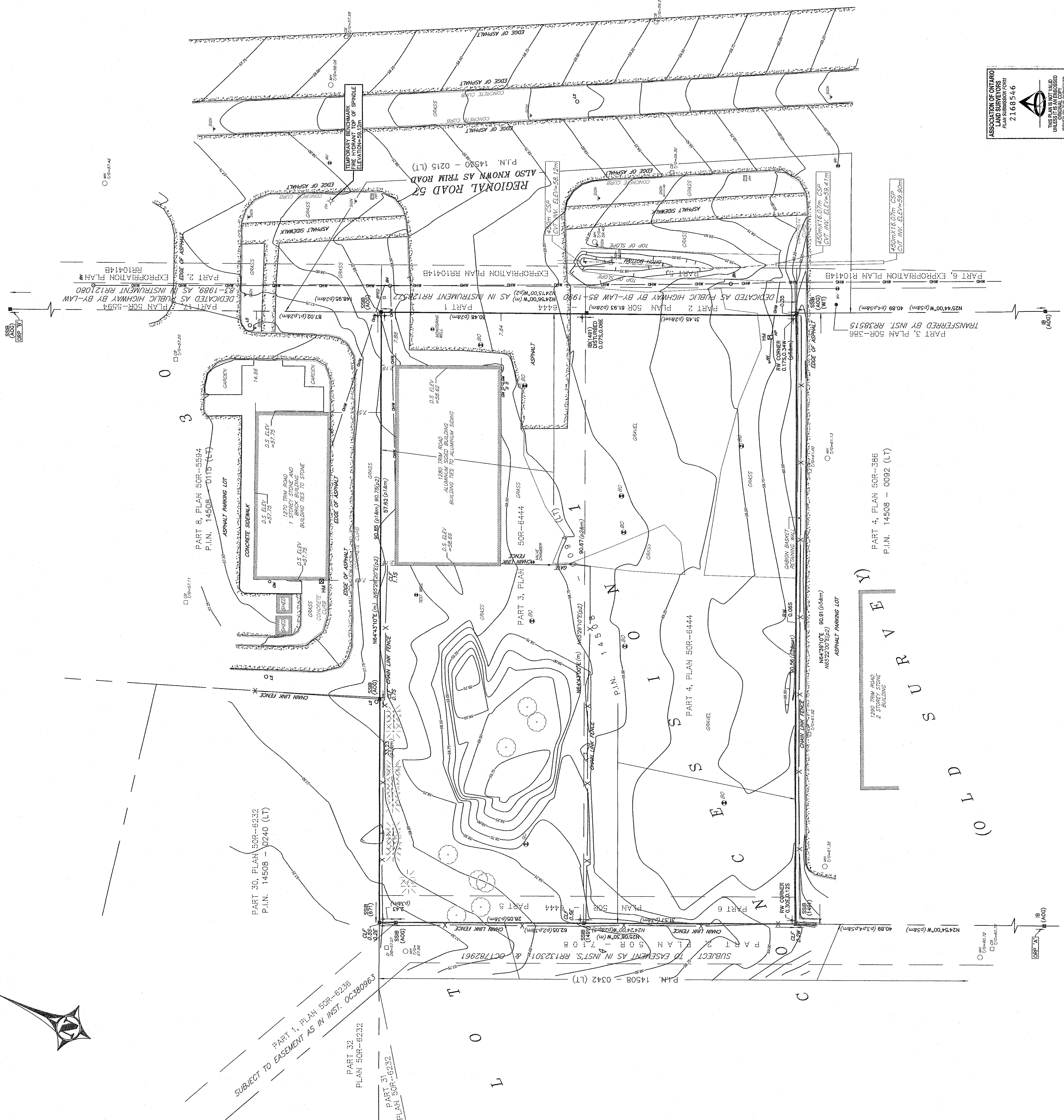

OWNER:
TRIM WORKS DEVELOPMENT LTD.
110 Place d'Orleans Drive
Orleans, ON K1C 2L9

PLANNING CONSULTANT:
Q9 PLANNING + DESIGN
C-43 Eccles Street
OTTAWA, ON K1R 6S3

CIVIL ENGINEER:
LRL ENGINEERING
5430 Canotek Road
Ottawa, ON K1J 9G2

LANDSCAPE ARCHITECTS:
RUHLAND & ASSOCIATES LTD.
200-1750 Courtwood Crescent
Ottawa, ON K2C 2B5

TRAFFIC ENGINEERING
J.L.RICHARDS & ASSOCIATES LTD.
1000-343 Preston Street
Ottawa, ON K1J 1N4



03 LOCATION PLAN
SCALE: NTS

SITE INFORMATION

SITE AREA: 5,620sm

NOTE THAT PROPERTY BOUNDARY INFORMATION HAS BEEN TAKEN FROM McINTOSH PERRY SURVEY DATED 7th May 2021 (PROJECT REF. NO. 22-0136)

BUILDING DATA:

AREA CALCULATIONS:

	GA	GFA
Building 1:	204.7sm	194.4sm
Building 2:	668.3sm	635.9sm
Building 3:	680.3sm	646.1sm
TOTAL	1,553.3sm	1,476.4sm
	16,720sf	15,892sf

ZONING

DESIGNATION:
IL H(21) Light Industrial Zone (Section 203 and 204)

PERMITTED USES:

- Day care
- Drive-through facility
- Medical facility
- Office
- Personal brewing facility
- Place of assembly
- Post office
- Production studio
- Service and repair shop
- Training centre
- Warehouse

PERMITTED USES LESS THAN 300sm PER USE TO A MAXIMUM CUMULATIVE OF 2,999sm:

- Automotive service station
- Bar
- Convenience store
- Personal service business
- Recreational and athletic facility (no area limitation)
- Restaurant

MAXIMUM FSI (Table 203):

2 times coverage
Permitted: 11,754sm
Proposed: 1,553.3sm (.28 times coverage)

SETBACKS (Table 203):

	Required	Proposed
Front & corner side yard:	7.5m	3.0m (north)
Interior side yard:	7.5m	6.0m (south)
Rear yard:	15.0m	9.5m (west)

MAXIMUM BUILDING HEIGHT (Table 203):

Permitted: 18m maximum
Proposed: 7m

MAXIMUM LOT COVERAGE (Table 203):

Permitted: 65% = 3,653sm
Proposed: 28% = 1,553sm

PARKING (Table 101):

Restaurant: 10.0 cars per 100 sm of GFA = 32
Pers. Serv.: 3.4 cars per 100sm of GFA = 18
Auto Serv.: 2.0 per service bay = 14

Required: 64 cars
Provided: 68 cars

PROVISIONS FOR DRIVE-THROUGH (Table 112):
7 before/at order board and a minimum total of 11

BICYCLE PARKING (Section 111):

Required: 6
Provided: 6

01 SITE, BUILDING and ZONING DATA
SCALE: NTS

North

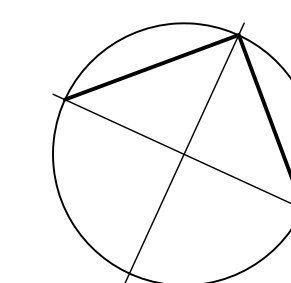

Revisions

No.	By	Description	Date
06	JAS	ISSUED FOR PRE-CONSULT	2023-03-02
07	JAS	ISSUED FOR REVIEW	2023-03-30
08	JAS	REVISED FOR REVIEW	2023-08-02
10	JAS	ISSUED FOR COORD.	2023-08-21
12	JAS	REVISED FOR COORD.	2023-09-14
13	JAS	ISSUED FOR SPA	2023-10-26
14	JAS	REVISED FOR COORD.	2024-01-18
15	JAS	REVISED FOR SPA	2024-01-29
16	JAS	REVISED FOR REVIEW	2024-05-17
17	JAS	REVISED FOR SPA	2024-06-25
18	JAS	REVISED FOR SPA	2024-07-26

Project

PLAZA TRIM WORKS DEVELOPMENT

1280 TRIM ROAD, ORLEANS, ON

Drawing

SITE PLAN

LEGAL DESCRIPTION:
PART OF LOT 30 CONCESSION 1
TOWNSHIP OF CUMBERLAND

Scale AS SHOWN

Stamp

Drawn

Checked

AK

Checked

JS



Project No.

Drawing No.

Date

22-168

07 JUNE 2022

SP-A01

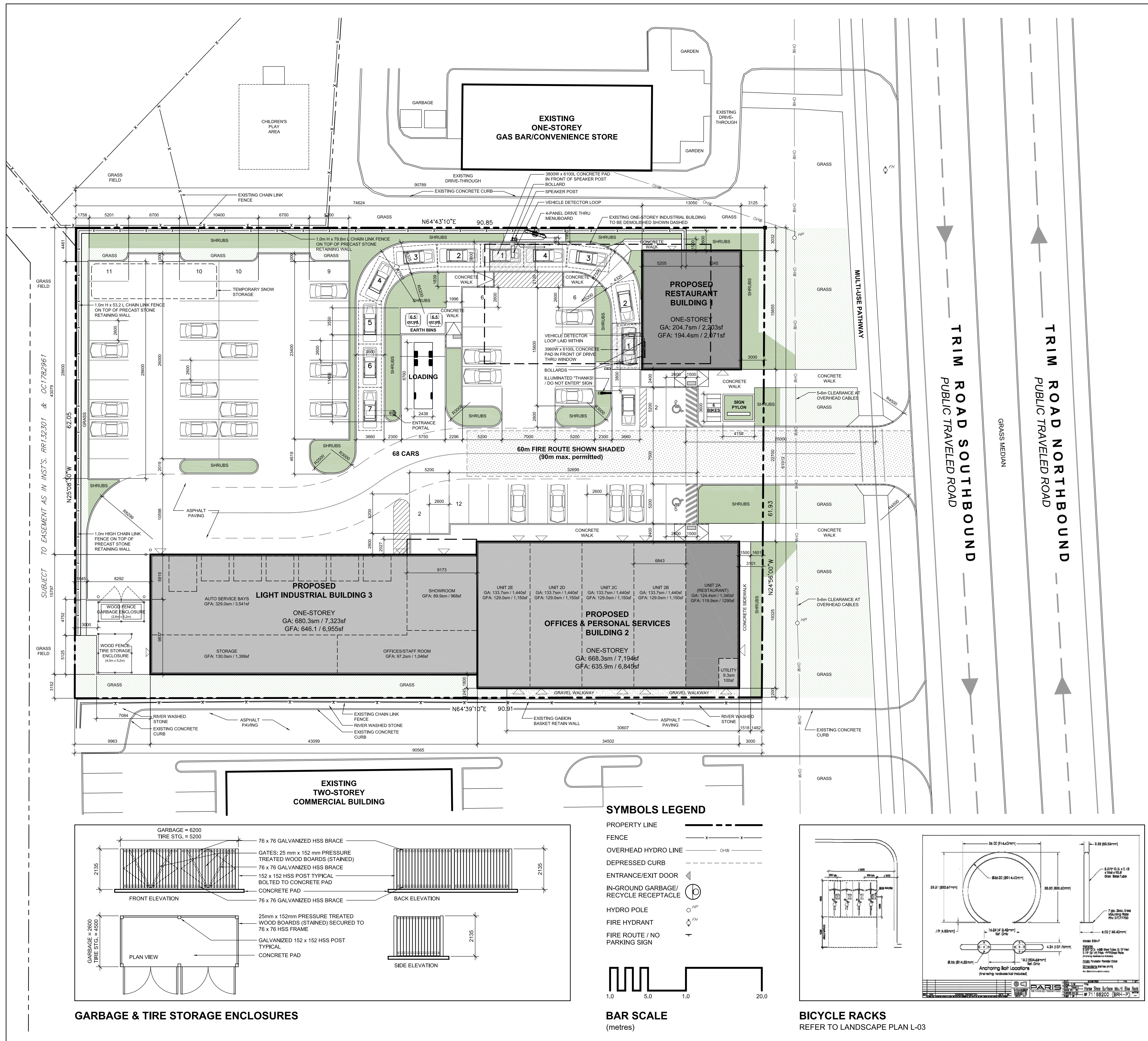

02 SITE PLAN
SCALE: 1:250



NO.	REVISIONS	BY	DATE
4.	AS RECORDED DRAWINGS	G.C.	04.05.14
3.	ISSUED FOR CONSTRUCTION	G.C.	02.08.29
2.	ISSUED FOR TENDER	G.C.	02.05.31
1.	UTILITY CIRCULATION	G.C.	02.02.27

NOTE:
The location of the utilities is approximate only, the exact location should be determined by consulting the municipal authorities and utility companies concerned.
The contractor shall prove the location of utilities and shall be responsible for adequate protection from damage.

**TRIM ROAD
SANITARY SEWER**
ORLEANS & CUMBERLAND WARDS

**NEW SANITARY SEWER
PLAN AND PROFILE
1+000 to 1+300**

R.G. HEWITT, P.ENG.
Director Infrastructure Services
W. NEWELL, P.ENG.
Manager Infrastructure Services

Ottawa
CONTRACT NO.
ETL01-2114
DWG. NO.
B-10942-4
SHEET 4 OF 23
Date: 04.05.14
Scale: 1:100
Vert: 1:100

TRIM ROAD

MATCH LINE 1+300 (Dwg. 10942-5)

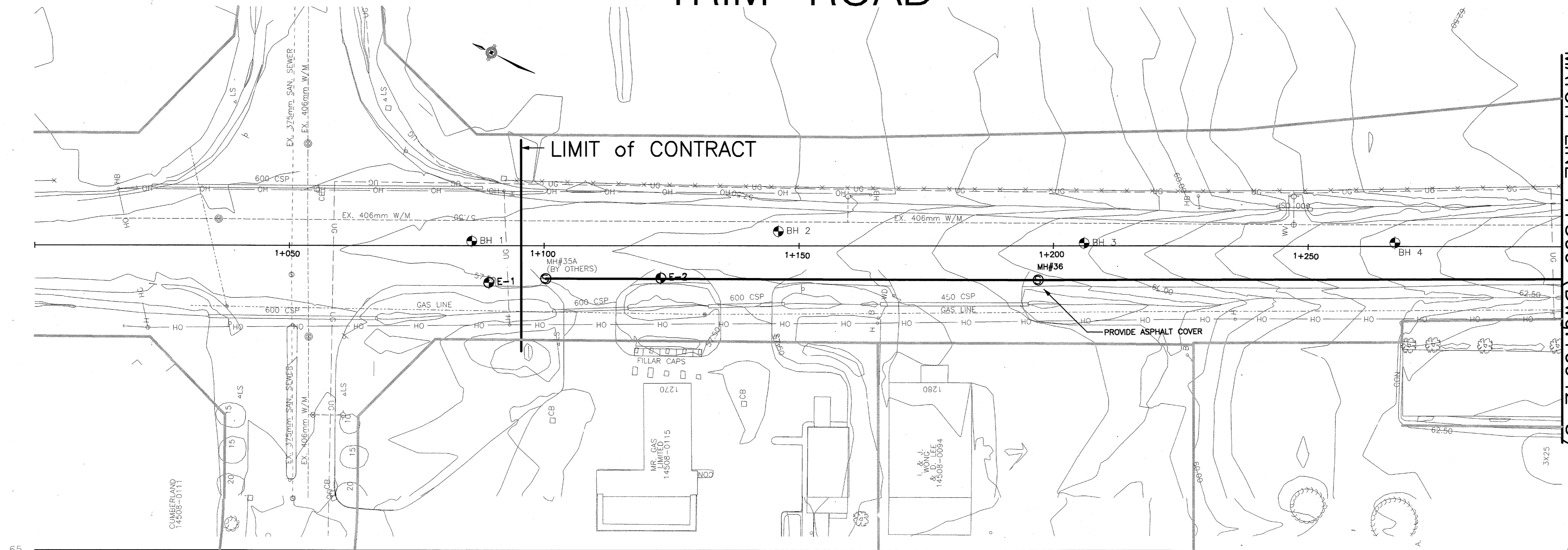

COORDINATES:
MH#36 384590.817, 5039460.332
384591.777, 5039461.416

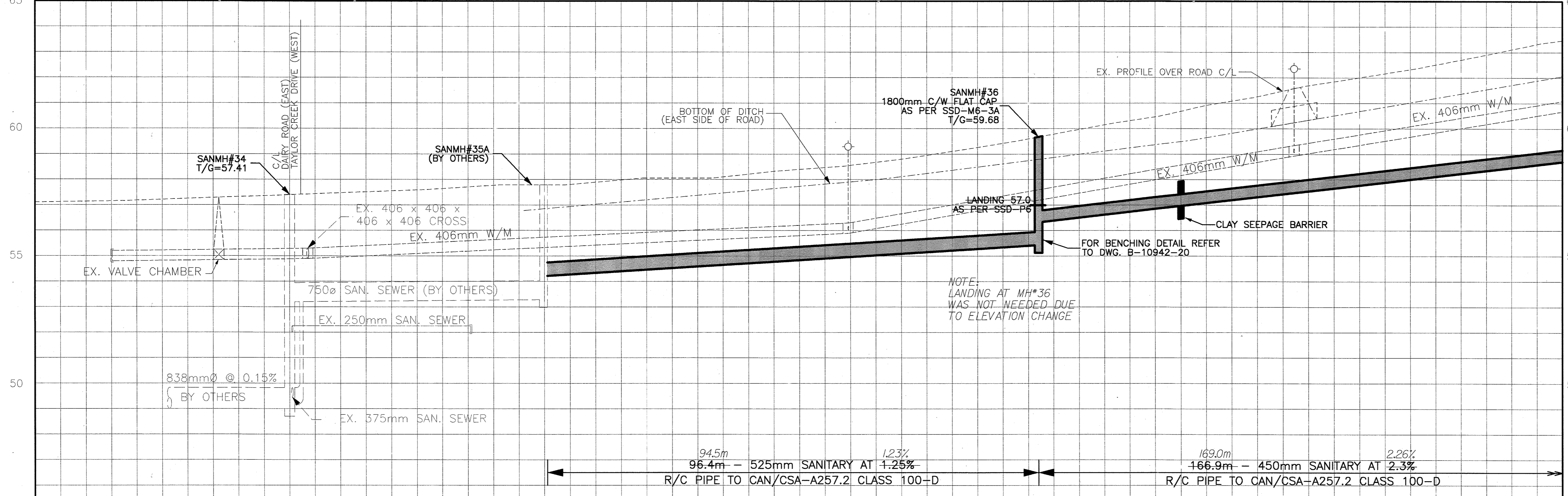

- NOTES:-
- 1- THE CONTRACTOR MAY PROPOSE DESIGN MODIFICATIONS (E.G. MH SPACING ADJUSTMENT) TO FACILITATE THE SEWER INSTALLATION USING ALTERNATIVE CONSTRUCTION METHODS. THE PROPOSED MODIFICATIONS HAVE TO BE SUBMITTED TO THE ENGINEER AT LEAST 2 WEEKS PRIOR TO CONSTRUCTION, REFER TO CONTRACT SPECIFICATIONS FOR DETAILS OF REQUIRED SUBMISSION.
 - 2- RESTORE DISTURBED AREAS, CULVERTS, SHOULDERS, PAVEMENT TO ORIGINAL CONDITION UNLESS INDICATED OTHERWISE ON THE DRAWINGS. MINIMIZE THE DISTURBANCE AT THE EXISTING TRIM ROAD.
 - 3- MAINTAIN AT LEAST 2 LANES OF TRAFFIC ON TRIM ROAD BEFORE 9:00 a.m. AND AFTER 3:00 p.m. (RUSH HOURS). MAINTAIN AT LEAST 1 LANE OF TRAFFIC BETWEEN 9:00 a.m. & 3:00 p.m. TRAFFIC CONTROL AS PER CITY OF OTTAWA REQUIREMENTS.
 - 4- PROVIDE ACCESS TO RESIDENCES AND SIDE ROADS AT ALL TIMES.
 - 5- THE CONTRACTOR SHALL SEPARATE THE NATIVE SILTY CLAY CRUST FROM THE HIGH WATER CONTENT GREY SILTY CLAY AND REUSE THE CLAY CRUST AS A BACKFILL. THE GREY SILTY CLAY MAY BE USED AS A BACKFILL IN NO SETTLEMENT SENSITIVE AREAS (OPEN FIELD) AND IF APPROVED BY THE ENGINEER. DEFICIENT QUANTITY OF BACKFILL MATERIAL TO BE REMEDIY WITH IMPORTED GRANULAR B, TYPE I OR II. REFER TO SPECIFICATION FOR DETAILS.
 - 6- FOR ROCK ELEVATIONS & SOIL INFORMATION, REFER TO GEOTECHNICAL REPORT BY J.D. PATERSON & ASSOCIATES.
 - 7- RADIUS PIPE TO BE OBTAINED BY OPENING PIPE JOINTS. UNLESS INDICATED OTHERWISE, THE MAXIMUM ALLOWABLE JOINT OPENING IS 10mm. THE MINIMUM ALLOWABLE PIPE RADIUS IS 300 METRES. THE TABLE SHOWN BELOW LISTS THE REQUIRED JOINT OPENING BASED ON PIPE SIZE AND RADIUS APPLICABLE TO THIS PROJECT.

	R=300m	R=400m	R=500m
750mm PIPE	7.5mm	5.6mm	4.5mm
675mm PIPE	6.8mm	5.1mm	4.1mm

ELEVATION AT	STATION	INVERT SAN. SEWER
57.10	1+000	
57.79	1+050.0	53.284 53.096 54.226 54.169
54.66	1+141	
58.40	1+150	
59.79	1+197.0	55.333 56.344 56.350
61.70	1+250	
63.47	1+300	

RECORD DRAWING
PRODUCED FROM INFORMATION PROVIDED BY: CITY INSPECTOR
DATE: 04.05.14
STANTEC CONSULTING LIMITED

TRIM ROAD

10+550

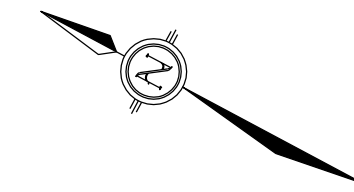

FOR CONTINUATION SEE DWG. P5
MATCHLINE STA. 10+500

MATCHLINE STA. 10+600
FOR CONTINUATION SEE DWG. P7

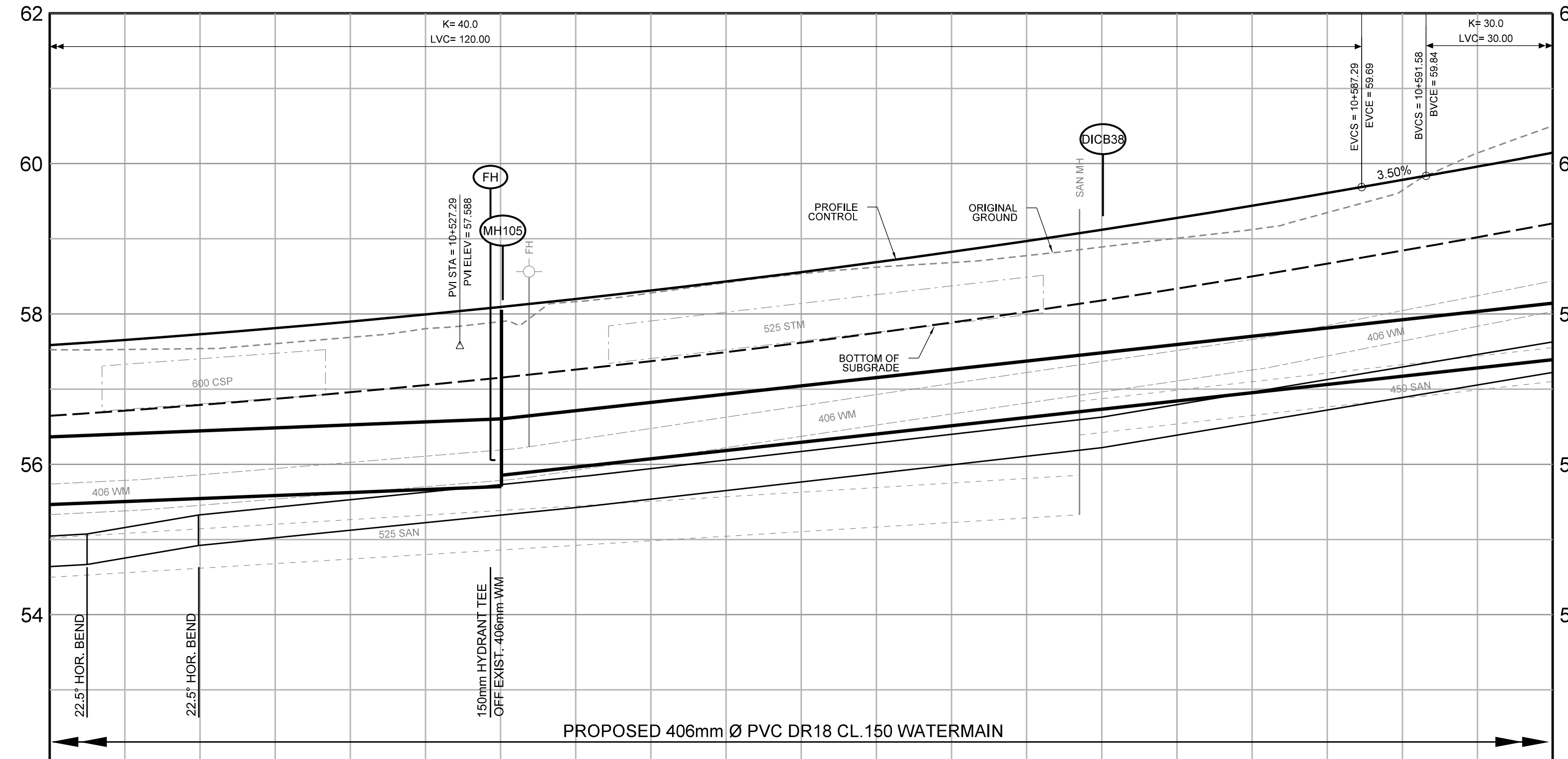
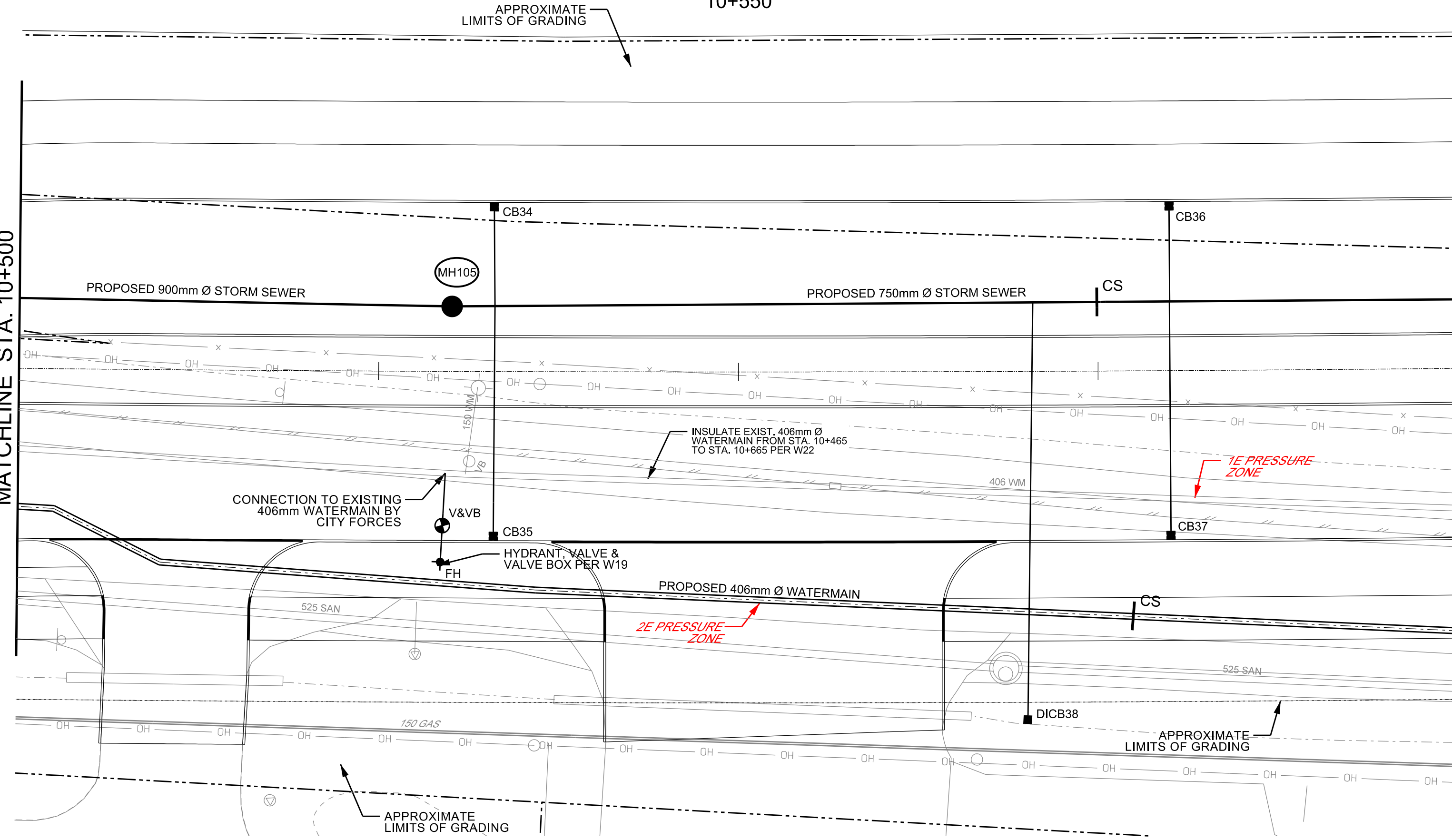

10+500	57.685	57.685	57.993	58.557	59.277	60.145
10+500	56.045	56.045	56.633	56.777	56.827	57.627
	55.229	55.229	56.633	56.777	56.827	57.627
	55.664	55.664	56.633	56.777	56.827	57.627
	55.91	55.91	56.633	56.777	56.827	57.627
	56.395	56.395	56.633	56.777	56.827	57.627
	56.63	56.63	56.633	56.777	56.827	57.627
10+525	55.825	55.825	56.633	56.777	56.827	57.627
10+525	55.705	55.705	56.633	56.777	56.827	57.627
10+525	55.395	55.395	56.633	56.777	56.827	57.627
10+550	55.880	55.880	56.633	56.777	56.827	57.627
10+550	56.171	56.171	56.633	56.777	56.827	57.627
10+575	56.627	56.627	56.633	56.777	56.827	57.627
10+575	56.783	56.783	56.633	56.777	56.827	57.627
10+600	57.627	57.627	56.633	56.777	56.827	57.627

FOR CONTINUATION SEE DWG. P7

TRIM ROAD REALIGNMENT & ST. JOSEPH BOULEVARD & OLD MONTREAL ROAD WIDENING

**GRADING & DRAINAGE
TRIM ROAD
STA. 10+500 TO STA. 10+600**

Contract No. **ISD11-5147**

Sheet P6 of P6

Asset No. _____

Asset Group _____

Des. G.B. / I.M. Chk'd. G.B. / K.L.

Dwn. R.V. / I.M. Chk'd. G.B. / K.L.

Utility Circ. No. _____ Index No. _____

Const. Inspector _____

Scale: HORIZONTAL 1:250 (0m to 10m), VERTICAL 1:50 (0m to 5m)

Robinson Consultants

AS-BUILT

RECORD INFORMATION PROVIDED BY CITY OF OTTAWA
ALL NUMERICAL VALUES THAT ARE NOT STROKED OUT AND REPLACED IN ITALICS ON AS-BUILT DRAWINGS ARE CONSIDERED TO BE DESIGN VALUES ONLY AND NOT MEASURED IN THE FIELD.

NOTE: The location of utilities is approximate only, the exact location should be determined by consulting the municipal authorities and utility companies concerned. The contractor shall prove the location of utilities and shall be responsible for adequate protection from damage.

No.	Description	By	Date (dd/mm/yy)
1	ISSUED FOR TENDER	K.L.	29.06.12
2	ISSUED FOR M.O.E. APPROVAL	K.L.	13.07.12
3	ISSUED FOR CONSTRUCTION	K.L.	21.09.12
4	REVISED DAIRY DRIVE STORM SEWER	K.L.	06.02.13
5	NEW 406mm WATERMAIN	K.L.	10.03.14
6	ISSUED FOR CONSTRUCTION - 406mm WATERMAIN ONLY	K.L.	20.05.14
7	<i>AS BUILT</i>	<i>K.L.</i>	<i>29.07.16</i>

STORM MANHOLE DATA							
No.	Station	Offset (m)	Type		Elevations		Grate to Invert
			Structure	Cover	Grate	Low Inv.	
MH105	10+530.09	4.52 L	701.011	S24.1/S25	58.05	55.71	2.34

CATCH BASIN DATA							
No.	Station	Offset (m)	Type		Elevations		Grate to Invert
			Structure	Grate	Grate	Low Inv.	
CB34	10+533.00	11.75 L	705.010	S19.1/400.020	57.95	56.45	1.50
CB35	10+532.83	11.77 R	705.010	S19.1/400.020	57.95	56.45	1.50
CB36	10+580.00	11.75 L	705.010	S19.1/400.020	59.24	57.54	1.70
CB37	10+580.00	11.75 R	705.010	S19.1/400.020	59.24	57.54	1.70
DICB38	10+570.02	24.21 R	705.030	403.010	58.34	57.24	1.10

CATCH BASIN LEAD DATA					
Structure to Structure	Dia.	Type	Length	Invert Elevations	
				Upstream	Downstream
CB34 TO MAIN	200	PVC	6.9	56.45	56.38
CB35 TO MAIN	200	PVC	16.0	56.45	56.29
CB36 TO MAIN	200	PVC	6.6	57.54	57.47
CB37 TO MAIN	200	PVC	16.3	57.54	57.38
DICB38 TO MAIN	200	PVC	28.7	57.24	56.95

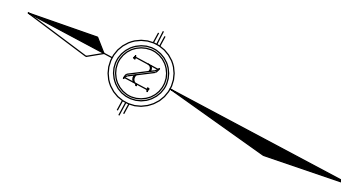

TRIM ROAD 10+650

FOR CONTINUATION SEE DWG. P6
MATCHLINE STA. 10+600

MATCHLINE STA. 10+700
FOR CONTINUATION SEE DWG. P8

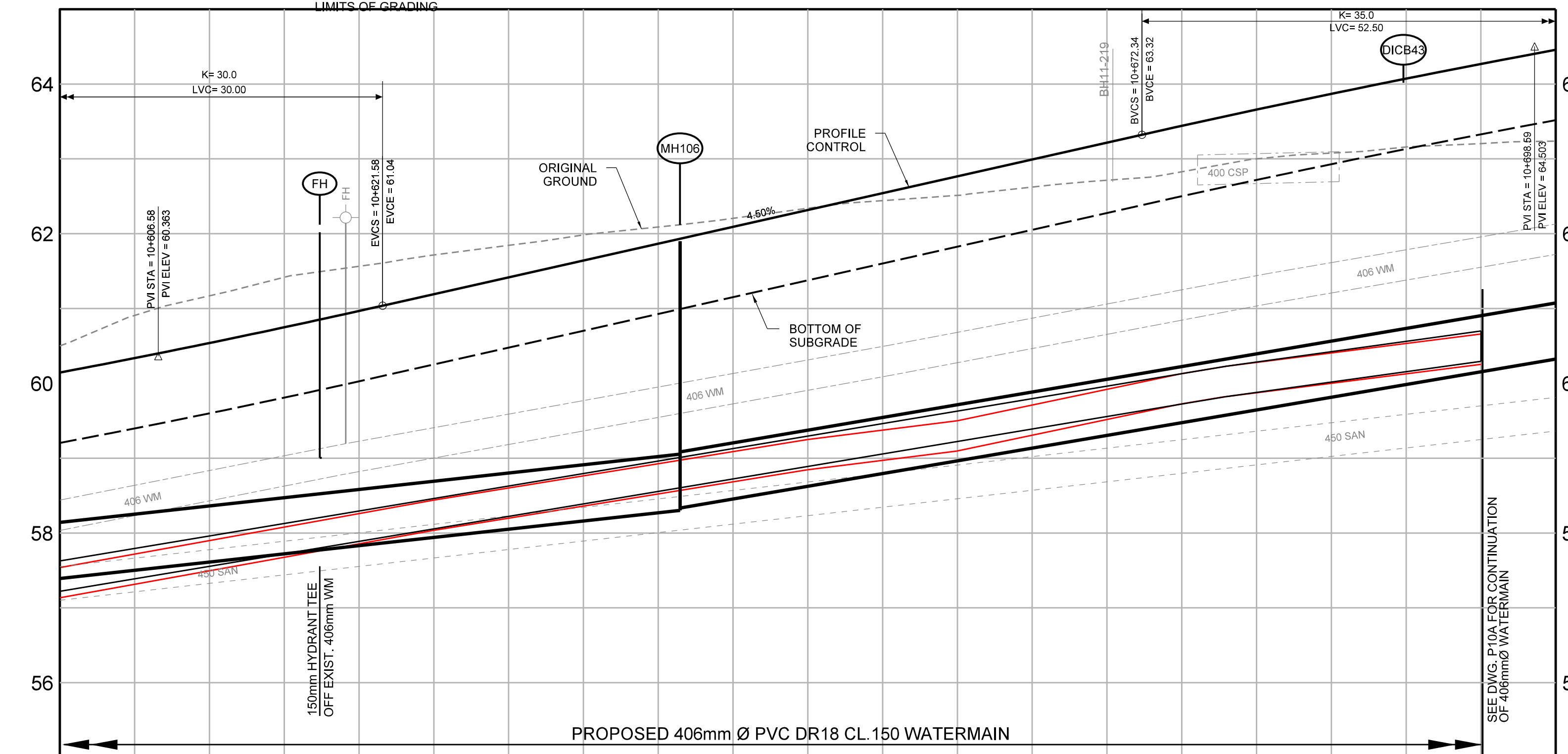
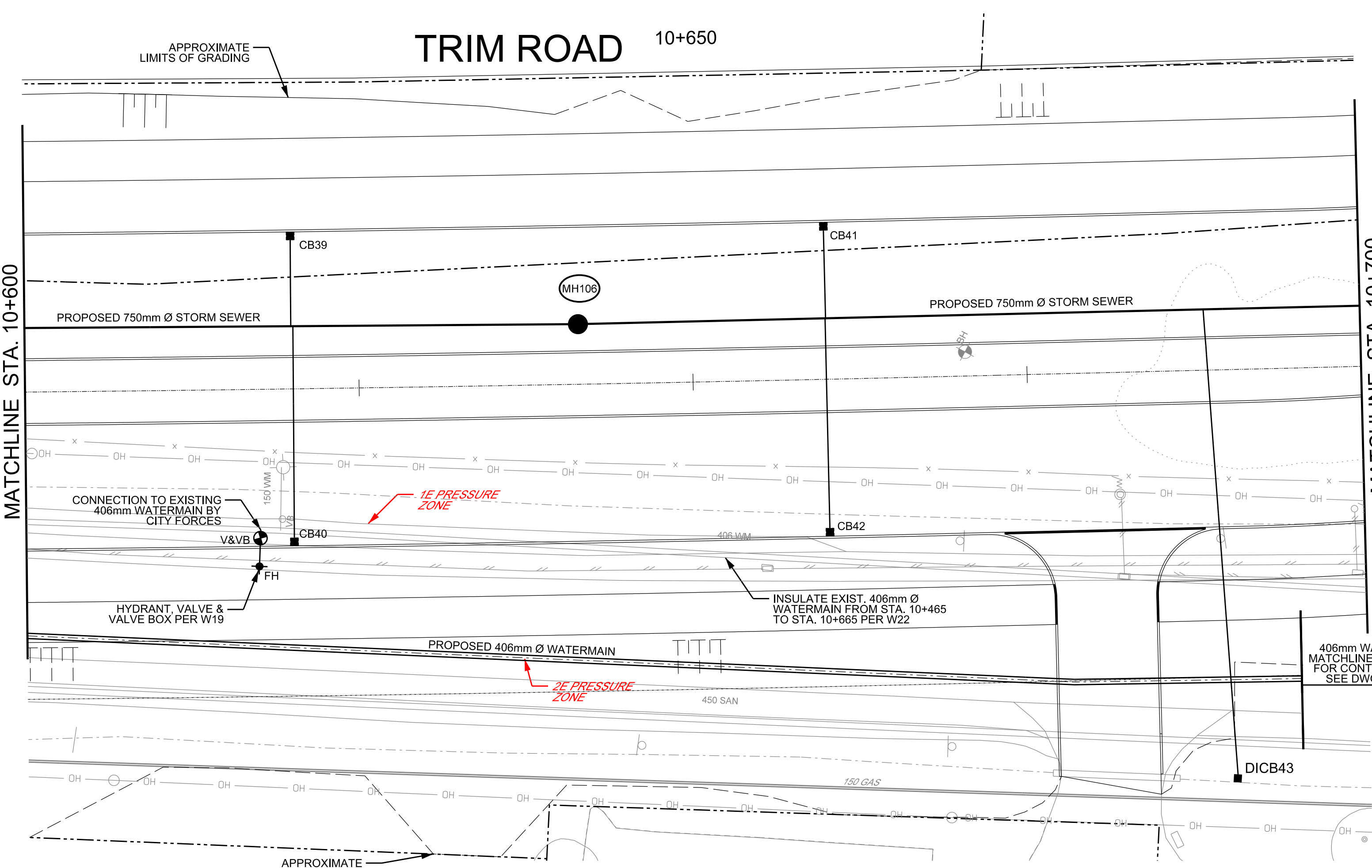

10+600	60.145	61.192	62.317	63.441	64.457	PROPOSED C PROFILE
	57.627	58.461	59.296	60.131	60.965	PROPOSED TOP OF WATERMAIN
	111.3m 750mm Ø CL 100-D STORM SEWER @ 2.20%		112.0m 750mm Ø CL 100-D STORM SEWER @ 3.40%			PROPOSED STORM SEWER INVERT
10+600	10+625	10+650	10+675	10+700		STATION

TRIM ROAD REALIGNMENT & ST. JOSEPH BOULEVARD & OLD MONTREAL ROAD WIDENING

GRADING & DRAINAGE TRIM ROAD STA. 10+600 TO STA. 10+700

Contract No. **ISD11-5147** Dwg. No. **P7**

Sheet **-** of **-**

Asset No. _____

Asset Group _____

Des. G.B. / I.M. Chk'd. G.B. / K.L.

Dwn. R.V. / I.M. Chk'd. G.B. / K.L.

Utility Circ. No. Index No. _____

Const. Inspector _____

Robinson Consultants

AS-BUILT

RECORD INFORMATION PROVIDED BY CITY OF OTTAWA

ALL NUMERICAL VALUES THAT ARE NOT STROKED OUT AND REPLACED IN ITALICS ON AS-BUILT DRAWINGS ARE CONSIDERED TO BE DESIGN VALUES ONLY AND NOT MEASURED IN THE FIELD.

Scale: HORIZONTAL 1:10 VERTICAL 1:2

NOTE: The location of utilities is approximate only, the exact location should be determined by consulting the municipal authorities and utility companies concerned. The contractor shall prove the location of utilities and shall be responsible for adequate protection from damage.

No.	Description	By	Date (dd/mm/yy)
1	ISSUED FOR TENDER	K.L.	29.06.12
2	ISSUED FOR M.O.E. APPROVAL	K.L.	13.07.12
3	ISSUED FOR CONSTRUCTION	K.L.	21.09.12
4	NEW 406mm WATERMAIN	K.L.	10.03.14
5	ISSUED FOR CONSTRUCTION - 406mm WATERMAIN ONLY	K.L.	20.05.14
6	AS BUILT	K.L.	29.07.16

No.	Station	Offset (m)	Type		Elevations		Grate to Invert
			Structure	Cover	Grate	Low Inv.	
MH106	10+641.67	4.50 L	701.011	S24.1/S25	61.89	58.30	3.59

No.	Station	Offset (m)	Type		Elevations		Grate to Invert
			Structure	Grate	Grate	Low Inv.	
CB39	10+620.00	11.75 L	705.010	S19.1/400.020	60.78	59.08	1.70
CB40	10+620.00	11.75 R	705.010	S19.1/400.020	60.78	59.08	1.70
CB41	10+660.00	11.75 L	705.010	S19.1/400.020	62.58	60.88	1.70
CB42	10+660.00	11.75 R	705.010	S19.1/400.020	62.58	60.88	1.70
DICB43	10+690.02	30.60 R	705.030	403.010	62.97	61.27	1.70

Structure to Structure	Dia.	Type	Length	Invert Elevations	
				Upstream	Downstream
CB39 TO MAIN	200	PVC	6.9	59.08	59.01
CB40 TO MAIN	200	PVC	16.0	59.08	58.92
CB41 TO MAIN	200	PVC	7.0	60.88	60.81
CB42 TO MAIN	200	PVC	15.7	60.88	60.72
DICB43 TO MAIN	200	PVC	34.8	61.27	60.92