

# D.B. Gray Engineering Inc.

*Stormwater Management - Grading & Drainage - Storm & Sanitary Sewers - Watermains*

700 Long Point Circle  
Ottawa, Ontario K1T 4E9

613-425-8044  
d.gray@dbgrayengineering.com

## SITE SERVICING STUDY & STORMWATER MANAGEMENT REPORT

415 WEST HUNT CLUB ROAD  
OTTAWA, ONTARIO

REPORT NO. 22093

DECEMBER 21, 2023  
REVISED JUNE 19, 2024  
REVISED SEPTEMBER 6, 2024

# CONTENTS

- 1.0 INTRODUCTION
- 2.0 WATER SERVICING
  - 2.1 WATER SUPPLY FOR FIREFIGHTING
  - 2.2 DOMESTIC WATER SUPPLY
- 3.0 SANITARY SERVICING
- 4.0 STORMWATER MANAGEMENT
  - 4.1 QUANTITY CONTROL
  - 4.2 QUALITY CONTROL
  - 4.3 STORM SERVICING
- 5.0 CONCLUSIONS

# LIST OF APPENDICES

- A WATER SERVICING
- B SANITARY SERVICING
- C STORMWATER MANAGEMENT & STORM SEWER SYSTEM
- D CITY OF OTTAWA PRE-CONSULTATION MEETING MINUTES & SERVICING STUDY CHECKLIST

## 1.0 INTRODUCTION

This report has been prepared in support of the Site Plan Control application for Costco's proposed two-storey office addition (having a 2,288 m<sup>2</sup> footprint) to 8,962 m<sup>2</sup> single-storey office building located on 2.74 ha of land at 415 Hunt Club Road (at the intersection of Roydon Place) in Ottawa, Ontario. Refer to Pre-Application Consultation meeting notes in Appendix D.

This report forms part of the site servicing and stormwater management design for the proposed development. Also refer to drawings C-1 to C-4 prepared by D.B. Gray Engineering Inc.

## 2.0 WATER SERVICING

### 2.1 WATER SUPPLY FOR FIREFIGHTING

The existing building has a sprinkler system, as will the proposed addition. The existing 150 mm water service connecting to the 305 mm Roydon Place municipal watermain supplies the existing sprinkler system and will supply the proposed system. The existing fire department connection (FDC) is located near the northeast corner of the building directly outside the water entry room next to the garbage area. The sprinkler system is expected to be designed, installed and maintained in accordance with NFPA standards and the Fire Underwriters Survey. There is an existing municipal Class AA fire hydrant in the Roydon Place municipal right-of-way located about 32 m unobstructed distance to the existing FDC, which is less than the maximum 45 m required by the Ontario Building Code; therefore, a private fire hydrant is not required.

In accordance with City of Ottawa Technical Bulletin ISTB-2021-03, when calculating the required fire flow where pipe sizing is not affected, the Ontario Building Code (OBC) method is to be used. Using the OBC method, the required fire flow for the entire existing building and proposed addition is calculated to be 9,000 L/min (150 L/s). In accordance with City of Ottawa Technical Bulletin ISTB-2021-03, when the OBC method yields a required fire flow of 9,000 L/min (150 L/s), the Fire Underwriters Survey (FUS) method is to be used instead. Using the FUS method, the required fire flow for the entire existing building and proposed addition is calculated to be 13,000 L/min (216.7 L/s). Refer to calculations in Appendix A.

The boundary conditions in the 305 mm municipal watermain in Roydon Place (at the existing 150 mm water service connection adjacent to the northeast corner of the existing building) provided by the City of Ottawa for the 216.7 L/s fire flow indicate a hydraulic grade line (HGL) of 126.2 m. Refer to Appendix A. This HGL calculates to 370 kPa (54 psi). Since the pressure is greater than the Ontario Building Code's minimum required pressure of 140 kPa (20 psi), there is an adequate water supply for firefighting from the existing municipal water distribution system.

In accordance with City of Ottawa Technical Bulletin ISTB-2018-02, the aggregate flow of all contributing fire hydrants within 150 m of the building shall not be less than the required fire flow. As per the City of Ottawa Technical Bulletin ISTB-2018-02 Appendix I:

Class	Distance (m)	Contribution (L/min)
AA	≤ 75	5,700
	> 75 and ≤ 150	3,800

There are five existing municipal Class AA fire hydrants within 150 m of the existing building and proposed addition each can contribute at least 3,800 L/min (63.3 L/s). The aggregate flow of all five contributing fire hydrants is 19,000 L/min (316.5 L/s), which is greater than the required fire flow of 13,000 L/min (216.7 L/s).

## **2.2 DOMESTIC WATER SUPPLY**

The existing 150 mm water service connection will provide an adequate domestic water supply. The proposed addition will be supplied via the internal plumbing of the existing building.

In accordance with the City of Ottawa Water Design Guidelines for the consumption rate (28,000 L/ha/day) and peaking factors, and based on a gross land area of 2.75 ha; the total daily demand and average daily demand was calculated to be 76.7 m<sup>3</sup>/day and 2.7 L/s, respectively; and the maximum daily demand and maximum hourly demand was calculated to be 4.0 L/s and 7.2 L/s, respectively. Refer to calculations in Appendix A. However, City staff has permitted that consumption rate be based on building area (including the proposed addition), which is about 11,300 m<sup>2</sup> or 1.13 ha. Since the building area is about 59% less than the land area, the calculated water demands are now 59% less. Therefore, the average daily demand is calculated to be 31.4 m<sup>3</sup>/day and 1.1 L/s, respectively; and the maximum daily demand and maximum hourly demand was calculated to be 1.6 L/s and 3.0 L/s, respectively.

The above calculated average daily demand based on building area is closer to the actual basic day demand of 19.7 m<sup>3</sup>/day (based on 13 months of water bills from January 2023 to February 2024) and the future daily demand of 23.1 m<sup>3</sup>/day (based on the current 660 employees and the future 775 employees after the addition is complete). Refer to calculations in Appendix A.

The boundary conditions in the 305 mm Roydon Place municipal watermain provided by the City of Ottawa (at the point of connection of the water service) indicate a minimum HGL of 124.8 m and a maximum HGL of 132.8 m. Refer to Appendix A. Based on these boundary conditions the pressure at the water meter is calculated to vary between 352 kPa (51 psi) and 431 kPa (62 psi). This is an acceptable range for the development.

## **3.0 SANITARY SERVICING**

In accordance with

- i. the City of Ottawa Sewer Design Guidelines for the average daily flow (28,000 L/ha/day) and peaking factor, and
- ii. City of Ottawa Technical Bulletin ISTB-2018-01 for the infiltration allowance.

The sanitary flow rate for the 2.74 ha property is calculated to be 4.90 L/s. The existing 150 mm sanitary sewer service at about 2.7% slope (23.71 L/s capacity) services the development. At the design flow rate, the sanitary sewer service is at 21% of its capacity. The existing 150 mm sanitary sewer service connects to the existing 250 mm Roydon Place municipal sanitary sewer, which at 0.30% slope has a capacity of 32.92 L/s. Refer to calculations in Appendix B. The proposed development is expected to have an acceptable impact on the 250 mm Roydon Place municipal sanitary sewer. The proposed addition will be serviced via a proposed sanitary sewer connecting to the existing sanitary sewer connection. At the design flow rate, the proposed 150 mm sanitary sewer service at 1% slope (14.43 L/s capacity) is at 3% of its capacity.

## **4.0 STORMWATER MANAGEMENT**

### **4.1 QUANTITY CONTROL**

The stormwater quantity control criterion used in this report is to control the post-development 100-year peak flow rate to the pre-development 5-year peak flow rate using a calculated runoff coefficient or 0.50, whichever is less.

In this report only the 2,855 m<sup>2</sup> area that is being redeveloped is considered. The maximum allowable release rate for this area is calculated to be 20.43 L/s. The Rational and Modified Rational Methods were used to calculate the post-development flow rates and corresponding storage volumes. Refer to calculations in Appendix C.

**Drainage Area I** (Uncontrolled Flow Off Site – 467 m<sup>2</sup>)

The areas around the perimeter of the building will drain uncontrolled off site. The flow rates are calculated at a time of concentration of 10 minutes.

	100-Year Event	5-Year Event
Maximum Flow Rate	13.84 L/s	7.09 L/s

**Drainage Area II** (Large Roof – 2,088 m<sup>2</sup>)

The 6 roof drains are to be flow control type roof drains which will restrict the flow of stormwater and cause it to pond on the roof. The roof drains are to be a Watts RD-100 c/w a Watts Adjustable Accutrol Weir (or approved equal) in the fully closed position, releasing 0.315 L/s (5 USgpm) at all ponding depths. The opening at the top of the flow control weir is to be a minimum 50 mm in diameter. A minimum of 10 scuppers each a minimum 600 mm wide are to be installed 150 mm above the roof drains. Refer to architectural for exact locations and details. The roof is to be designed to carry the load of water having a 50 mm depth at the scuppers or 200 mm depth at the roof drains. Refer to structural.

	100-Year Event	5-Year Event
Maximum Release Rate	2.92 L/s	1.89 L/s
Maximum Depth at Roof Drain	150 mm	114 mm
Maximum Volume Stored	118.28 m <sup>3</sup>	59.90 m <sup>3</sup>

**Drainage Area III** (Small Roof – 216 m<sup>2</sup>)

The one roof drain is to be flow control type roof drains which will restrict the flow of stormwater and cause it to pond on the roof. The roof drain is to be a Watts RD-100 c/w a Watts Adjustable Accutrol Weir (or approved equal) in the fully closed position, releasing 0.315 L/s (5 USgpm) at all ponding depths. The opening at the top of the flow control weir is to be a minimum 50 mm in diameter. A minimum of 2 scuppers, each a minimum 300 mm wide, are to be installed 150 mm above the roof drains. Refer to architectural for exact locations and details. The roof is to be designed to carry the load of water having a 50 mm depth at the scuppers or 200 mm depth at the roof drains. Refer to structural.

	100-Year Event	5-Year Event
Maximum Release Rate	0.76 L/s	0.32 L/s
Maximum Depth at Roof Drain	150 mm	125 mm
Maximum Volume Stored	9.35 m <sup>3</sup>	5.38 m <sup>3</sup>

**Summary**

The maximum post-development release rate during the 100-year event is calculated to be 17.52 L/s, which is 47% less than pre-development flow rate and 13% less than the maximum allowable release rate. To achieve this release rate, a maximum storage volume of 127.63 m<sup>3</sup> is required and provided during the 100-year event. The maximum post-development release rate during the 5-year event is calculated to be 9.29 L/s, which is 54% less than pre-development flow rate and maximum allowable release rate. The proposed development is expected to have a positive impact on the municipal storm sewer.

	100-Year Event	5-Year Event
Pre-development Flow Rate	32.96 L/s	20.03 L/s
Maximum Allowable Release Rate	20.03 L/s	20.03 L/s
Maximum Release Rate	17.52 L/s	9.29 L/s
Maximum Volume Required	127.63 m <sup>3</sup>	65.28 m <sup>3</sup>
Maximum Volume Stored	127.63 m <sup>3</sup>	65.28 m <sup>3</sup>

## 4.2 QUALITY CONTROL

There are no existing quality control measures on the subject property and no permanent measures are proposed. However, since the proposed addition will replace an existing parking area and since the drainage from a roof is considered 'clean' the proposed addition will inherently improve the quality of stormwater released from the property.

An Erosion & Sediment Control Plan has been developed to be implemented during construction. Refer to drawing C-2 and notes 2.1 to 2.6 on drawing C-4:

- i. Sediment capture filter sock inserts are to be installed in all existing and proposed catch-basins and catch-basin/manholes adjacent to and within the site.
- ii. A silt fence barrier is to be installed along the perimeter of the site.
- iii. Any material deposited on the public road is to be removed.

## 4.3 STORM SERVICING

Since the proposed addition will replace an existing parking area and since the drainage from the parking area drains currently uncontrolled into the existing private storm sewer system (upstream of the existing ICD) the peak restricted flow rate from the roof of the proposed addition draining into the existing private storm sewer system will be significantly less than it is currently. Drainage from the roof will drain to an existing 250 mm storm sewer. Refer to calculations in Appendix C.

## 5.0 CONCLUSIONS

1. A private fire hydrant is not required.
2. There is an adequate water supply for firefighting from the existing municipal water distribution system.
3. There is an acceptable range of water pressures in the existing municipal water distribution system.
4. The post-development sanitary flow rates will be adequately handled by the existing and proposed sanitary sewer services and private sanitary sewer system.
5. The proposed development is expected to have an acceptable impact on the existing municipal sanitary sewer.
6. An Erosion & Sediment Control Plan has been developed to be implemented during construction.
7. The maximum post-development release rate during the 100-year event is less than the maximum allowable release rate.

8. The proposed development is expected to have an acceptable impact on the existing municipal storm sewer.

Prepared by D.B. Gray Engineering Inc.



NOT VALID UNLESS  
SIGNED & DATED

## **APPENDIX A**

### WATER SERVICING





*Stormwater Management - Grading & Drainage - Storm & Sanitary Sewers - Watermains*

700 Long Point Circle  
Ottawa, Ontario K1T 4E9

613-425-8044  
d.gray@dbgrayengineering.com

October 16, 2023

415 Hunt Club Rd  
2-Storey Office Expansion  
Ottawa, Ontario

FIRE FLOW CALCULATIONS  
OBC Method

Q = Required water supply in litres  
=  $KVS_{Total}$

K = Water supply coefficient as per OBC A-3.2.5.7. Table 1  
= 10 Group C Occupancy, Building is of combustible construction with fire separations and fire resistance ratings in accordance with Subsection 3.2.2.

V = Building volume in cubic meters

	Floor Area (sq.m)	Height (m)	Volume (cu.m)
1st Floor:	2,164.5	4.4	9,523.8
2nd Floor:	2,164.5	3.3	7,142.9
			16,666.7

$S_{Total}$  = Total of spatial coefficients from exposure distances  
=  $1.0 + S_{Side\ 1} + S_{Side\ 2} + S_{Side\ 3} + S_{Side\ 4}$

	Spatial Coefficient	Exposure Distance (m)	
$S_{Side\ 1}$	0.3	7	(to NW property line)
$S_{Side\ 2}$	0.5	0	(to Existing Building)
$S_{Side\ 3}$	0.0	21	(to centerline of road)
$S_{Side\ 4}$	0.0	97	(to SW property line)
$S_{Total}$	1.8		Need not exceed 2.0

Q = 333,333 L  
= 9,000 L/min as per OBC A-3.2.5.7. Table 2  
= 150 L/s

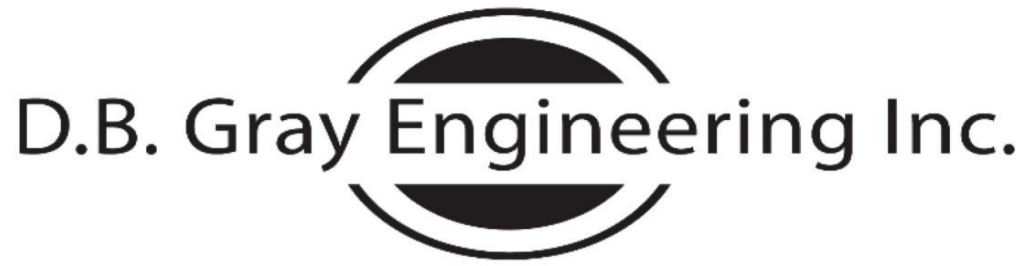

Stormwater Management - Grading & Drainage - Storm & Sanitary Sewers - Watermains

700 Long Point Circle  
Ottawa, Ontario K1T 4E9

613-425-8044  
d.gray@dbgrayengineering.com

November 23, 2023

REVISED December 14, 2023

REVISED August 22, 2024

415 Hunt Club Rd

Ottawa, Ontario

## FIRE FLOW CALCULATIONS FUS Method

RFF = Required Fire Flow in litres per minute  
=  $220CA^{0.5}$

C = Construction Coefficient related to the type of construction of the building  
= 1.0 Type III Ordinary Construction

A = Total Effective Floor Area in square meters of the building

2nd Floor:	2,288	sq.m
1st Floor:	11,250	sq.m
	13,538	sq.m

RFF = 25,598 L/min  
= 26,000 L/min (rounded to nearest 1,000 L/min)

Occupancy and Contents Adjustment Factor

-15% Limited Combustible Contents  
= -3,900 L/min Occupancy and Contents Adjustment Factor

RFF = 22,100 L/min

Automatic Sprinkler Protection Credit

30% Sprinkler system designed, installed and maintained in accordance with NFPA standards  
10% Standard water supply for both the sprinkler system and fire department hose lines  
= 8,840 L/min Automatic Sprinkler Protection Credit

Exposure Adjustment Charge

Side	Charge	Distance	Construction	Length	Storeys	Factor
North	0%	over 30 m				
East	0%	over 30 m				
South	0%	over 30 m				
West	0%	over 30 m				
	0%	Exposure Adjustment Charge				
=	0	L/min Exposure Adjustment Charge				

RFF = 13,260 L/min  
= 13,000 L/min (rounded to nearest 1,000 L/min)  
= 216.7 L/s

Elevation at Fire Hydrant 88.43 m ASL

216.7 L/s FIRE FLOW: 126.2 m ASL      Static Pressure at Fire Hydrant  
54 psi      370 kPa

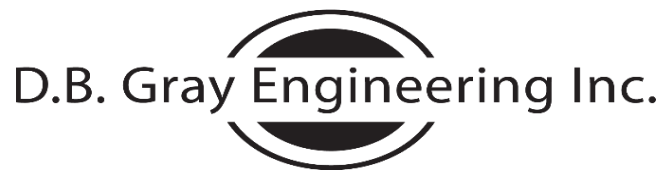

Stormwater Management - Grading & Drainage - Storm & Sanitary Sewers - Watermains  
700 Long Point Circle  
Ottawa, Ontario K1T 4E9

613-425-8044  
d.gray@dbgrayengineering.com

23-Nov-23  
REVISED 15-Dec-23

## 415 Hunt Club Road Ottawa, Ontario

### Water Demand

COMMERCIAL DAILY AVERAGE: 28,000 L /gross ha / day (as per Ottawa Design Guidelines)  
2.75 ha (land area)  
76868 L/day  
8 hour day  
160.1 L/min      2.7 L/s      42.3 USgpm

MAXIMUM DAILY DEMAND: 1.5 (Peaking Factor as per Ottawa Design Guidelines)  
240.2 L/min      4.0 L/s      63.5 USgpm

MAXIMUM HOURLY DEMAND: 1.8 (Peaking Factor as per Ottawa Design Guidelines)  
432.4 L/min      7.2 L/s      114.2 USgpm

---

Elevation of Water Meter: 88.85 m ASL  
Finish Floor Elevation: 87.95 m ASL

MINIMUM HGL: 124.8 m ASL      Static Pressure at Water Meter  
51 psi      352 kPa

MAXIMUM HGL: 132.8 m ASL      62 psi      431 kPa



Douglas Gray &lt;d.gray@dbgrayengineering.com&gt;

---

**RE: 415 Hunt Club Rd - Boundary Conditions Request**

1 message

---

**Armstrong, Justin** <justin.armstrong@ottawa.ca>  
To: Douglas Gray <d.gray@dbgrayengineering.com>  
Cc: Laurent Brosseau <l.brosseau@dbgrayengineering.com>

Fri, Dec 8, 2023 at 9:31 AM

Hi Doug,

See below and attached.

The following are boundary conditions, HGL, for hydraulic analysis 415 Hunt Club Road, (zone 2W2C) assumed to be a dual connection connected to the 305mm watermain on Royon Place (see attached PDF for location).

Minimum HGL: 124.8 m

Maximum HGL: 132.8 m

Max Day + Fire Flow (216.7 L/s): 126.2 m

These are for current conditions and are based on computer model simulation.

*Disclaimer: The boundary condition information is based on current operation of the city water distribution system. The computer model simulation is based on the best information available at the time. The operation of the water distribution system can change on a regular basis, resulting in a variation in boundary conditions. The physical properties of watermains deteriorate over time, as such must be assumed in the absence of actual field test data. The variation in physical watermain properties can therefore alter the results of the computer model simulation.*

Thank you,

**Justin Armstrong, P.Eng.**

Project Manager

Planning, Real Estate and Economic Development Department – Direction générale de la planification, des biens immobiliers et du développement économique

Development Review - West Branch

City of Ottawa | Ville d'Ottawa

[110 Laurier Avenue West Ottawa, ON](#) | 110, avenue. Laurier Ouest. Ottawa (Ontario) K1P 1J1

613.580.2424 ext./poste 21746, [justin.armstrong@ottawa.ca](mailto:justin.armstrong@ottawa.ca)

---

**From:** Douglas Gray <[d.gray@dbgrayengineering.com](mailto:d.gray@dbgrayengineering.com)>  
**Sent:** November 23, 2023 7:11 AM  
**To:** Armstrong, Justin <[justin.armstrong@ottawa.ca](mailto:justin.armstrong@ottawa.ca)>  
**Cc:** laurent Brosseau <[l.brosseau@dbgrayengineering.com](mailto:l.brosseau@dbgrayengineering.com)>  
**Subject:** 415 Hunt Club Rd - Boundary Conditions Request

**CAUTION: This email originated from an External Sender. Please do not click links or open attachments unless you recognize the source.**

**ATTENTION : Ce courriel provient d'un expéditeur externe. Ne cliquez sur aucun lien et n'ouvrez pas de pièce jointe, excepté si vous connaissez l'expéditeur.**

Hi Justin

We are working on an addition to the Costco building at 415 HuntClub Rd. The existing building is serviced via 150mm connection to the 300mm City watermain on Roydon Place (refer to the attached Site servicing Plan). Please provide the boundary conditions at this location . We have calculated the following expected demands.

Average daily demand: 2.7 L/s.

Maximum daily demand: 4.0 L/s.

Maximum hourly daily demand: 7.2 L/s

Fire Flow demand: 216.7 L/s

Fire Flow + Max Day: 220.7 L/s

Our calculations are attached.

Thanks, Doug

Douglas Gray

**D. B. Gray Engineering Inc.**

[700 Long Point Circle](#)

[Ottawa, ON K1T 4E9](#)

613-425-8044

This e-mail originates from the City of Ottawa e-mail system. Any distribution, use or copying of this e-mail or the information it contains by other than the intended recipient(s) is unauthorized. Thank you.

Le présent courriel a été expédié par le système de courriels de la Ville d'Ottawa. Toute distribution, utilisation ou reproduction du courriel ou des renseignements qui s'y trouvent par une personne autre que son destinataire prévu est interdite. Je vous remercie de votre collaboration.

---

 **415 Hunt Club Road November 2023.pdf**  
1157K

# Boundary Conditions for 415 Hunt Club Road



**Legend**

- Public
- Private

07-Mar-24

REVISED 22-Aug-24

415 Hunt Club Road  
Ottawa, Ontario

Water Demand  
(Based on Water Bills)

Date Range		# of Days	Current Water Usage (m <sup>3</sup> )	Current Daily Water Usage (m <sup>3</sup> )	Current # of Employees 660 Current Daily Usage per Employee (m <sup>3</sup> )	Future # of Employees 775 Estimated Future Daily Water Usage (m <sup>3</sup> )	Estimated Future Daily Water Usage October to April (m <sup>3</sup> )
January 10, 2023	February 8, 2023	30	450	15.0	0.023	17.6	17.6
February 9, 2023	March 10, 2023	30	415	13.8	0.021	16.2	16.2
March 11, 2023	April 9, 2023	30	380	12.7	0.019	14.9	14.9
April 10, 2023	May 9, 2023	30	474	15.8	0.024	18.6	18.6
May 10, 2023	June 8, 2023	30	1379	46.0	0.070	54.0	
June 9, 2023	July 8, 2023	30	1130	37.7	0.057	44.2	
July 9, 2023	August 7, 2023	30	539	18.0	0.027	21.1	
August 8, 2023	September 6, 2023	30	438	14.6	0.022	17.1	
September 7, 2023	October 6, 2023	30	860	28.7	0.043	33.7	
October 7, 2023	November 5, 2023	30	347	11.6	0.018	13.6	13.6
November 6, 2023	December 5, 2023	30	434	14.5	0.022	17.0	17.0
December 6, 2023	January 4, 2024	30	370	12.3	0.019	14.5	14.5
January 5, 2024	February 3, 2024	30	453	15.1	0.023	17.7	17.7
Average =			590	19.7	0.030	23.1	16.3



## **APPENDIX B**

### SANITARY SERVICING



## **APPENDIX C**

### STORMWATER MANAGEMENT

## STORMWATER MANAGEMENT CALCULATIONS

The orifice calculations are based on the following formula:

$$Q = C_d \times A_o \sqrt{2gh} \times 1000$$

where:

Q = flowrate in litres per second

$C_d$  = coefficient of discharge

$A_o$  = orifice area in sq.m.

g = 9.81 m/s<sup>2</sup>

h = head above orifice in meters

Flow control roof drain calculations are based on the following formula:

$$Q = N \times S \times d \times F$$

where:

Q = flowrate in litres per second

N = number of roof drains

S = slots per weir

d = pond depth at roof drain in mm

F = flowrate through each slot

Storage calculations for the 'Small Roof' are based on the following formula for volume of a cone:

$$V = (A \times d)/3$$

where:

V = volume in m<sup>3</sup>

A = ponding area in m<sup>2</sup>

d = ponding depth in meters

Storage calculations for the 'Large Roof' are based on the volume of a cone plus the following formula for the volume of a prism:

$$V = (A \times d)/2$$

where:

V = volume in m<sup>3</sup>

A = ponding area m<sup>2</sup>

d = ponding depth in meters



Tag: **RD-100** \_\_\_\_\_

## Large Area Roof Drain

**SPECIFICATION:** Watts Drainage RD-100 epoxy coated cast iron roof drain with flashing clamp with integral gravel stop, self-locking polyethylene dome, and no hub (standard) outlet.

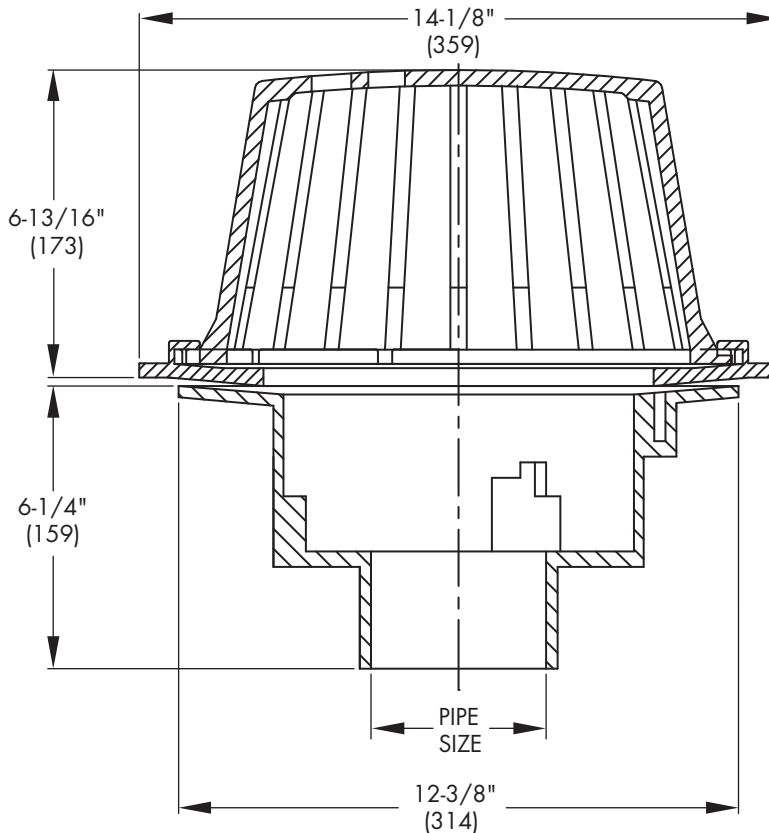

Free Area Sq. In.
137

**Deck opening 10" (254)  
with sump receiver 13-1/4" (337)**

Components	
B2	B2-FLG
B2-DM	FC-2

Pipe Sizing (Select One)		
Suffix	Description	
2	2" (51) Pipe Size	<input type="checkbox"/>
3	3" (76) Pipe Size	<input type="checkbox"/>
4	4" (102) Pipe Size	<input type="checkbox"/>
5	5" (127) Pipe Size	<input type="checkbox"/>
6	6" (152) Pipe Size	<input type="checkbox"/>

Outlet Type (Select One)		
Suffix	Description	
NH	No Hub (MJ)	<input type="checkbox"/>
P	Push On	<input type="checkbox"/>
T	Threaded Outlet	<input type="checkbox"/>
X	Inside Caulk	<input type="checkbox"/>

Options (Select One or More)		
Suffix	Description	
-13	Galvanized Body & Flashing Clamp	<input type="checkbox"/>
-A	Accutrol Flow Restrictor	<input type="checkbox"/>
-B	Sump Receiver	<input type="checkbox"/>
-D	Underdeck Clamp	<input type="checkbox"/>
-F	Adjustable Extension Flange	<input type="checkbox"/>
-GSS	Stainless Steel Ballast Guard	<input type="checkbox"/>
-K	Ductile Iron Dome	<input type="checkbox"/>
-K13	Galvanized Dome	<input type="checkbox"/>
-K40	Ductile Iron Low Dome (4" high)	<input type="checkbox"/>
-K81	Rough Bronze Dome	<input type="checkbox"/>
-K80	Aluminum Dome	<input type="checkbox"/>
-K83	SS Mesh Covered Dome	<input type="checkbox"/>
-L	Vandal Proof Dome	<input type="checkbox"/>
-R	2" External Water Dam	<input type="checkbox"/>
-SO	Side Outlet (2,3,4" only)	<input type="checkbox"/>
-V	Fixed Extension (1-1/2", 2", 3", 4")	<input type="checkbox"/>

Optional Body Material		
Suffix	Description	
-60	PVC Body w/Socket Outlet	<input type="checkbox"/>
-61	ABS Body w/Socket Outlet	<input type="checkbox"/>

Job Name \_\_\_\_\_ Contractor \_\_\_\_\_

Job Location \_\_\_\_\_ Contractor's P.O. No. \_\_\_\_\_

Engineer \_\_\_\_\_ Representative \_\_\_\_\_

WATTS Drainage reserves the right to modify or change product design or construction without prior notice and without incurring any obligation to make similar changes and modifications to products previously or subsequently sold. See your WATTS Drainage representative for any clarification. Dimensions are subject to manufacturing tolerances.



Specification Drainage Products

USA: 100 Watts Road, Spindale, NC, 28160-2298; TEL: 828-288-2179 TOLL-FREE: 1-800-338-2581 www.watts.com



# Adjustable Accutrol Weir

Tag: \_\_\_\_\_

## Adjustable Flow Control for Roof Drains

### ADJUSTABLE ACCUTROL (for Large Sump Roof Drains only)

For more flexibility in controlling flow with heads deeper than 2", Watts Drainage offers the Adjustable Accutrol. The Adjustable Accutrol Weir is designed with a single parabolic opening that can be covered to restrict flow above 2" of head to less than 5 gpm per inch, up to 6" of head. To adjust the flow rate for depths over 2" of head, set the slot in the adjustable upper cone according to the flow rate required. Refer to Table 1 below.  
 Note: Flow rates are directly proportional to the amount of weir opening that is exposed.

#### EXAMPLE:

For example, if the adjustable upper cone is set to cover 1/2 of the weir opening, flow rates above 2" of head will be restricted to 2-1/2 gpm per inch of head.

Therefore, at 3" of head, the flow rate through the Accutrol Weir that has 1/2 the slot exposed will be:  
 [5 gpm (per inch of head) x 2 inches of head ] + 2-1/2 gpm (for the third inch of head) = 12-1/2 gpm.

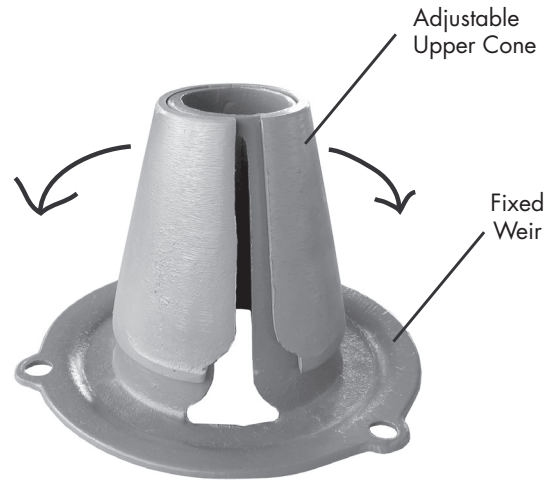
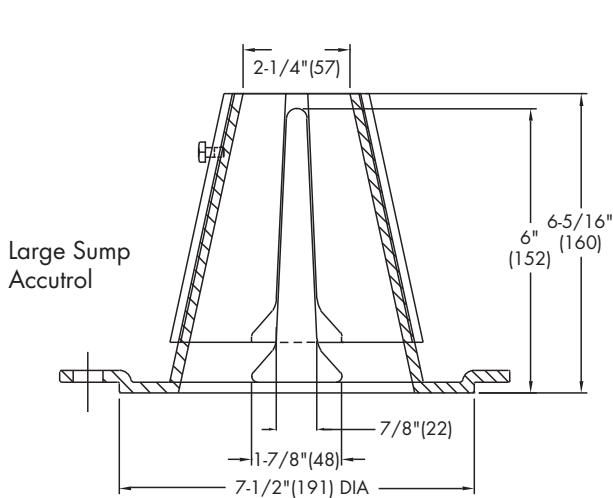

1/2 Weir Opening Exposed Shown Above

TABLE 1. Adjustable Accutrol Flow Rate Settings

Weir Opening Exposed	1"	2"	3"	4"	5"	6"
	Flow Rate (gallons per minute)					
Fully Exposed	5	10	15	20	25	30
3/4	5	10	13.75	17.5	21.25	25
1/2	5	10	12.5	15	17.5	20
1/4	5	10	11.25	12.5	13.75	15
Closed	5	5	5	5	5	5

Job Name \_\_\_\_\_  
 Job Location \_\_\_\_\_  
 Engineer \_\_\_\_\_

Contractor \_\_\_\_\_  
 Contractor's P.O. No. \_\_\_\_\_  
 Representative \_\_\_\_\_

Watts product specifications in U.S. customary units and metric are approximate and are provided for reference only. For precise measurements, please contact Watts Technical Service. Watts reserves the right to change or modify product design, construction, specifications, or materials without prior notice and without incurring any obligation to make such changes and modifications on Watts products previously or subsequently sold.

USA: Tel: (800) 338-2581 • Fax: (828) 248-3929 • Watts.com  
 Canada: Tel: (905) 332-4090 • Fax: (905) 332-7068 • Watts.ca  
 Latin America: Tel: (52) 81-1001-8600 • Fax: (52) 81-8000-7091 • Watts.com



## SUMMARY TABLES

100-YEAR EVENT					
Drainage Area	Pre-Development Flow Rate (L/s)	Maximum Allowable Release Rate (L/s)	Maximum Release Rate (L/s)	Maximum Volume Required (cu.m)	Maximum Volume Stored (cu.m)
AREA I (Uncontrolled Flow Off Site)	-	-	13.84	-	-
AREA II (Roof)	-	-	2.92	118.28	118.28
AREA III (Roof)	-	-	0.76	9.35	9.35
TOTAL	32.96	20.03	17.52	127.63	127.63

5-YEAR EVENT					
Drainage Area	Pre-Development Flow Rate (L/s)	Maximum Allowable Release Rate (L/s)	Maximum Release Rate (L/s)	Maximum Volume Required (cu.m)	Maximum Volume Stored (cu.m)
AREA I (Uncontrolled Flow Off Site)	-	-	7.09	-	-
AREA II (Roof)	-	-	1.89	59.90	59.90
AREA III (Roof)	-	-	0.32	5.38	5.38
TOTAL	20.03	20.03	9.29	65.28	65.28

## 415 Hunt Club Rd

Ottawa, Ontario

## STORMWATER MANAGEMENT CALCULATIONS

## Modified Rational Method

## PRE-DEVELOPMENT CONDITIONS

## 100-YEAR EVENT

As per SWM report by EXP dated April 25, 2012, the 100yr release rate is 10.28 L/s. However, this release rate does not include the uncontrolled flow off the site. Including the uncontrolled flow, the 100yr release rate is:

38.82 L/s

## 100-YEAR EVENT

			C
Roof Area:	0	sq.m	1.00
Hard Area:	198	sq.m	1.00
Gravel Area:	0	sq.m	0.875
Soft Area:	2,573	sq.m	0.25
Total Catchment Area:	2,771	sq.m	0.30

Airport Formula (Used when C &lt; 0.40)

$$T_c = \frac{3.26 \cdot (1.1 - C) \cdot L^{1/2}}{S_w^{0.33}} \text{ min}$$

Sheet Flow Distance (L):	35	m
Slope of Land (Sw):	1	%
Time of Concentration (Sheet Flow):	15.4	min

Rainfall Intensity (i):	141	mm/hr
100-Year Pre-Development Flow Rate (2.78AiC):	32.96	L/s

## 5-YEAR EVENT

As per SWM report by EXP dated April 25, 2012, the 5yr release rate is 10.28 L/s. However, this release rate does not include the uncontrolled flow off the site. Including the uncontrolled flow, the 5yr release rate is:

24.28 L/s

## 5-YEAR EVENT &amp; MAXIMUM ALLOWABLE RELEASE RATE

			C
Roof Area:	0	sq.m	0.90
Hard Area:	198	sq.m	0.90
Gravel Area:	0	sq.m	0.70
Soft Area:	2,573	sq.m	0.20
Total Catchment Area:	2,771	sq.m	0.25

Airport Formula (Used when C &lt; 0.40)

$$T_c = \frac{3.26 \cdot (1.1 - C) \cdot L^{1/2}}{S_w^{0.33}} \text{ min}$$

Sheet Flow Distance (L):	24	m
Slope of Land (Sw):	2.5	%
Time of Concentration (Sheet Flow):	10.0	min

Rainfall Intensity (i):	104	mm/hr
5-Year Pre-Development Flow Rate (2.78AiC):	20.03	L/s



# 100-YEAR EVENT

## DRAINAGE AREA I (Uncontrolled Flow Off Site)

(100-YEAR EVENT)

			C
Roof Area:	0	sq.m	1.00
Hard Area:	216	sq.m	1.00
Gravel Area:	0	sq.m	0.875
Permeable Paver Area:	0	sq.m	0.375
Soft Area:	<u>251</u>	<u>sq.m</u>	<u>0.25</u>
Total Catchment Area:	467	sq.m	0.60
Area (A):	467	sq.m	
Time of Concentration:	10	min	
Rainfall Intensity (i):	179	mm/hr	
Runoff Coeficient (C):	0.60		
Flow Rate (2.78AiC):	13.84	L/s	

## DRAINAGE AREA II (Large Roof)

(100-YEAR EVENT)

Total Catchment Area: 2,088 sq.m C  
1.00

No. of Roof Drains: 6  
Wier Opening: 0 (fully closed adjustable flow control roof drain)

Depth at Roof Drains: 150 mm

Maximum Weir Release Rate: 1.89 L/s Pond Area: 1887 sq.m  
Maximum Scupper Release Rate: 1.03 L/s  
Maximum Total Release Rate: 2.92 L/s Maximum Volume Stored: 118.28 cu.m

Maximum Volume Required: 118.28 cu.m

Time (min)	i (mm/hr)	2.78AiC (L/s)	Weir Release Rate (L/s)	Scupper Release Rate (L/s)	Stored Rate (L/s)	Required Storage Volume (cu.m)
10	178.6	103.65	1.89	0.00	101.75	61.05
15	142.9	82.94	1.89	0.00	81.05	72.95
20	120.0	69.63	1.89	0.00	67.73	81.28
25	103.8	60.28	1.89	0.00	58.39	87.58
30	91.9	53.33	1.89	0.00	51.43	92.58
35	82.6	47.93	1.89	0.00	46.04	96.69
40	75.1	43.62	1.89	0.00	41.73	100.14
45	69.1	40.08	1.89	0.00	38.19	103.11
50	64.0	37.12	1.89	0.00	35.23	105.69
55	59.6	34.61	1.89	0.00	32.72	107.97
60	55.9	32.44	1.89	0.00	30.55	109.99
75	47.3	27.43	1.89	0.00	25.54	114.92
90	41.1	23.86	1.89	0.07	21.90	118.28
105	36.5	21.19	1.89	0.52	18.77	118.28
120	32.9	19.09	1.89	0.77	16.43	118.28
135	30.0	17.41	1.89	0.92	14.60	118.28
150	27.6	16.03	1.89	0.99	13.14	118.28
165	25.6	14.86	1.89	1.02	11.95	118.28
180	23.9	13.87	1.89	1.03	10.95	118.28
210	21.1	12.27	1.89	0.99	9.39	118.28
240	19.0	11.03	1.89	0.93	8.21	118.28
270	17.3	10.04	1.89	0.84	7.30	118.28
300	15.9	9.22	1.89	0.76	6.57	118.28
330	14.7	8.54	1.89	0.68	5.97	118.28
360	13.7	7.96	1.89	0.60	5.48	118.28
390	12.9	7.47	1.89	0.52	5.05	118.28
420	12.1	7.03	1.89	0.45	4.69	118.28
450	11.5	6.65	1.89	0.38	4.38	118.28
480	10.9	6.31	1.89	0.31	4.11	118.28
510	10.4	6.01	1.89	0.25	3.87	118.28
540	9.9	5.74	1.89	0.19	3.65	118.28
570	9.5	5.49	1.89	0.14	3.46	118.28
600	9.1	5.27	1.89	0.09	3.29	118.28
630	8.7	5.06	1.89	0.04	3.13	118.28
660	8.4	4.88	1.89	0.00	2.99	118.28
690	8.1	4.70	1.89	0.00	2.81	116.31
720	7.8	4.54	1.89	0.00	2.65	114.46

# DRAINAGE AREA III (Small Roof)

(100-YEAR EVENT)

Total Catchment Area: 216 sq.m C  
1.00

No. of Roof Drains: 1  
Wier Opening: 0 (fully closed adjustable flow control roof drain)

Depth at Roof Drain: 150 mm

Maximum Weir Release Rate: 0.32 L/s Pond Area: 187 sq.m  
Maximum Scupper Release Rate: 0.44 L/s  
Maximum Total Release Rate: 0.76 L/s Maximum Volume Stored: 9.35 cu.m

Maximum Volume Required: 9.35 cu.m

Time (min)	i (mm/hr)	2.78AiC (L/s)	Weir Release Rate (L/s)	Scupper Release Rate (L/s)	Stored Rate (L/s)	Required Storage Volume (cu.m)
10	178.6	10.72	0.32	0.00	10.41	6.24
15	142.9	8.58	0.32	0.00	8.27	7.44
20	120.0	7.20	0.32	0.00	6.89	8.26
25	103.8	6.24	0.32	0.00	5.92	8.88
30	91.9	5.52	0.32	0.01	5.19	9.35
35	82.6	4.96	0.32	0.19	4.45	9.35
40	75.1	4.51	0.32	0.30	3.90	9.35
45	69.1	4.15	0.32	0.37	3.46	9.35
50	64.0	3.84	0.32	0.41	3.12	9.35
55	59.6	3.58	0.32	0.43	2.83	9.35
60	55.9	3.36	0.32	0.44	2.60	9.35
75	47.3	2.84	0.32	0.44	2.08	9.35
90	41.1	2.47	0.32	0.42	1.73	9.35
105	36.5	2.19	0.32	0.39	1.48	9.35
120	32.9	1.98	0.32	0.36	1.30	9.35
135	30.0	1.80	0.32	0.33	1.15	9.35
150	27.6	1.66	0.32	0.30	1.04	9.35
165	25.6	1.54	0.32	0.28	0.94	9.35
180	23.9	1.44	0.32	0.25	0.87	9.35
210	21.1	1.27	0.32	0.21	0.74	9.35
240	19.0	1.14	0.32	0.18	0.65	9.35
270	17.3	1.04	0.32	0.15	0.58	9.35
300	15.9	0.95	0.32	0.12	0.52	9.35
330	14.7	0.88	0.32	0.10	0.47	9.35
360	13.7	0.82	0.32	0.08	0.43	9.35
390	12.9	0.77	0.32	0.06	0.40	9.35
420	12.1	0.73	0.32	0.04	0.37	9.35
450	11.5	0.69	0.32	0.03	0.35	9.35
480	10.9	0.65	0.32	0.01	0.32	9.35
510	10.4	0.62	0.32	0.00	0.31	9.35
540	9.9	0.59	0.32	0.00	0.28	9.01
570	9.5	0.57	0.32	0.00	0.25	8.64
600	9.1	0.54	0.32	0.00	0.23	8.26
630	8.7	0.52	0.32	0.00	0.21	7.87
660	8.4	0.50	0.32	0.00	0.19	7.48
690	8.1	0.49	0.32	0.00	0.17	7.08
720	7.8	0.47	0.32	0.00	0.15	6.67

# 5-YEAR EVENT

## DRAINAGE AREA I (Uncontrolled Flow Off Site)

(5-YEAR EVENT)

			C
Roof Area:	0	sq.m	0.90
Hard Area:	216	sq.m	0.90
Gravel Area:	0	sq.m	0.70
Permeable Paver Area:	0	sq.m	0.30
Soft Area:	<u>251</u>	<u>sq.m</u>	<u>0.20</u>
Total Catchment Area:	467	sq.m	0.52
Area (A):	467	sq.m	
Time of Concentration:	10	min	
Rainfall Intensity (i):	104	mm/hr	
Runoff Coeficient (C):	0.52		
Flow Rate (2.78AiC):	7.09	L/s	

## DRAINAGE AREA II (Large Roof)

(5-YEAR EVENT)

Total Catchment Area:	2,088	sq.m	C	0.90
No. of Roof Drains:	6			
Wier Opening:	0		(fully closed adjustable flow control roof drain)	
Depth at Roof Drains:	114	mm		
Maximum Release Rate:	1.89	L/s	Pond Area:	1283 sq.m
			Maximum Volume Stored:	59.90 cu.m
			Maximum Volume Required:	59.90 cu.m

Time (min)	i (mm/hr)	2.78AiC (L/s)	Release Rate (L/s)	Stored Rate (L/s)	Required Storage Volume (cu.m)
10	104.2	54.43	1.89	52.54	31.52
15	83.6	43.65	1.89	41.76	37.58
20	70.3	36.70	1.89	34.81	41.77
25	60.9	31.81	1.89	29.92	44.88
30	53.9	28.17	1.89	26.28	47.30
35	48.5	25.35	1.89	23.45	49.25
40	44.2	23.08	1.89	21.19	50.86
45	40.6	21.23	1.89	19.33	52.20
50	37.7	19.67	1.89	17.78	53.33
55	35.1	18.35	1.89	16.46	54.31
60	32.9	17.21	1.89	15.32	55.14
75	27.9	14.57	1.89	12.68	57.05
90	24.3	12.69	1.89	10.80	58.30
105	21.6	11.28	1.89	9.38	59.11
120	19.5	10.17	1.89	8.28	59.60
135	17.8	9.28	1.89	7.39	59.84
150	16.4	8.55	1.89	6.66	59.90
165	15.2	7.93	1.89	6.04	59.79
180	14.2	7.41	1.89	5.52	59.56
210	12.6	6.56	1.89	4.67	58.80
240	11.3	5.90	1.89	4.01	57.71
270	10.3	5.37	1.89	3.48	56.38
300	9.5	4.94	1.89	3.05	54.85
330	8.8	4.58	1.89	2.69	53.17
360	8.2	4.27	1.89	2.38	51.36
390	7.7	4.01	1.89	2.11	49.43
420	7.2	3.77	1.89	1.88	47.41
450	6.8	3.57	1.89	1.68	45.30
480	6.5	3.39	1.89	1.50	43.13
510	6.2	3.23	1.89	1.34	40.89
540	5.9	3.08	1.89	1.19	38.59
570	5.7	2.95	1.89	1.06	36.24
600	5.4	2.83	1.89	0.94	33.84
630	5.2	2.72	1.89	0.83	31.41
660	5.0	2.62	1.89	0.73	28.93
690	4.8	2.53	1.89	0.64	26.42
720	4.7	2.45	1.89	0.55	23.88

## DRAINAGE AREA III (Small Roof)

(5-YEAR EVENT)

Total Catchment Area:	216	sq.m	C	0.90
No. of Roof Drains:	1			
Wier Opening:	0		(fully closed adjustable flow control roof drain)	
Depth at Roof Drain:	125	mm		
Maximum Release Rate:	0.32	L/s	Pond Area:	129 sq.m
			Maximum Volume Stored:	5.38 cu.m
			Maximum Volume Required:	5.38 cu.m

Time (min)	i (mm/hr)	2.78AiC (L/s)	Release Rate (L/s)	Stored Rate (L/s)	Required Storage Volume (cu.m)
10	104.2	5.63	0.32	5.32	3.19
15	83.6	4.52	0.32	4.20	3.78
20	70.3	3.80	0.32	3.48	4.18
25	60.9	3.29	0.32	2.98	4.46
30	53.9	2.91	0.32	2.60	4.68
35	48.5	2.62	0.32	2.31	4.84
40	44.2	2.39	0.32	2.07	4.97
45	40.6	2.20	0.32	1.88	5.08
50	37.7	2.03	0.32	1.72	5.16
55	35.1	1.90	0.32	1.58	5.22
60	32.9	1.78	0.32	1.46	5.27
75	27.9	1.51	0.32	1.19	5.36
90	24.3	1.31	0.32	1.00	5.38
105	21.6	1.17	0.32	0.85	5.36
120	19.5	1.05	0.32	0.74	5.30
135	17.8	0.96	0.32	0.64	5.22
150	16.4	0.88	0.32	0.57	5.12
165	15.2	0.82	0.32	0.51	5.00
180	14.2	0.77	0.32	0.45	4.87
210	12.6	0.68	0.32	0.36	4.57
240	11.3	0.61	0.32	0.29	4.25
270	10.3	0.56	0.32	0.24	3.89
300	9.5	0.51	0.32	0.20	3.52
330	8.8	0.47	0.32	0.16	3.13
360	8.2	0.44	0.32	0.13	2.73
390	7.7	0.41	0.32	0.10	2.31
420	7.2	0.39	0.32	0.07	1.89
450	6.8	0.37	0.32	0.05	1.46
480	6.5	0.35	0.32	0.04	1.02
510	6.2	0.33	0.32	0.02	0.57
540	5.9	0.32	0.32	0.00	0.12
570	5.7	0.31	0.31	0.00	0.00
600	5.4	0.29	0.29	0.00	0.00
630	5.2	0.28	0.28	0.00	0.00
660	5.0	0.27	0.27	0.00	0.00
690	4.8	0.26	0.26	0.00	0.00
720	4.7	0.25	0.25	0.00	0.00



Stormwater Management - Grading & Drainage - Storm & Sanitary Sewers - Watermains

700 Long Point Circle  
Ottawa, Ontario K1T 4E9

613-425-8044  
d.gray@dbgrayengineering.com

## STORM SEWER CALCULATIONS

Rational Method

FIVE YEAR EVENT

415 Hunt Club Rd  
2-Storey Office Expansion  
Ottawa, Ontario

August 22, 2024

Manning's Roughness Coefficient: 0.013

Location		Individual				Cumulative				Sewer Data								
		Roof C = 0.90 (ha)	Hard C = 0.90 (ha)	Gravel C = 0.70 (ha)	Soft C = 0.20 (ha)			Time (min)	Rainfall Intensity (mm/hr)	Flow Rate (L/s)	Length (m)	Nominal Diameter (mm)	Actual Diameter (mm)	Slope (%)	Velocity (m/s)	Q <sub>Full</sub> Capacity (L/s)	Time (min)	Q / Q <sub>Full</sub>
From	To					2.78AC	2.78AC											
CB-1	Existing		0.0184		0.0088	0.0509	0.0509	10.00	104	5.31	14.7	250	251	2.00	1.72	85.00	0.14	0.06
	525 ST																	
												Existing Pipe						
Roof	Existing	0.2304				0.5765	0.5765	10.00	104	60.06	18.9	250	251	1.00	1.21	60.10	0.26	1.00
	Boxed Culvert					FLOW THROUGH FLOW CONTROL RDs:				2.21	18.9	250	251	1.00	1.21	60.10	0.26	0.04
												Existng 525 ST in Roydon Place						
												525	533	0.92	1.92	429.48		

## **APPENDIX D**

### **PRE-CONSULTATION MEETING NOTES & CITY OF OTTAWA SERVICING STUDY CHECKLIST**



## **Pre-Application Consultation Meeting Minutes**

**Property Address:** 415 Hunt Club West

**Location:** Virtual – Microsoft Teams

**Meeting Date:** October 13, 2022

**Attendees:** Lisa Stern – Planner  
Sarah Ezio - Planner  
Steven Payne – Planning Coop  
Randolph Wang – Urban Design  
Justin Armstrong – Engineer  
Mark Richardson - Forester  
Patrick Rutherford  
Paul Robinson  
Arthur Gordon  
Douglas Grey  
Patrick England

**Regrets:** Molly Smith – Planner (File Lead)  
Josiane Gervais – Transportation

## **Planning**

1. Complex Site Plan required. Please be aware of policy or procedures changes as a result of Bill 109.
2. Unclear if minor variances required. Please speak with Molly prior to submission.
3. When submitting, elevations and site plan will need to include the whole site and if overflow parking on adjacent sites, include that in the plan as well.
4. If possible, bicycle parking should be near main entrances and covered
5. Trees in the ROW should be protected.
6. Additional landscaping and tree planting should be provided. Please provide foundation plantings around the buildings and look for opportunities to break up hardscaping with shade plantings.
7. Direct connections from the sidewalks should be provided.
8. Please provide an entrance from the arterial mainstreet alternatively, please enhance the entrance feature so that it is prominent from Hunt Club.
9. Secondary Bird Hazard Zone (due to the Airport's area of influence) – this may impact stormwater storage and tree planting types. Please avoid fruit bearing plants, full list of plant material is available from the airport.
10. Planning Rationale Required.
11. Bird Friendly Guidelines Apply.

Feel free to contact Molly Smith, Planner (File Lead), at [molly.smith@ottawa.ca](mailto:molly.smith@ottawa.ca) for follow-up questions.

## **Urban Design**

1. A Design Brief is required as part of the submission. The Terms of Reference is attached for convenience.
2. Hunt Club Road is a designated Scenic Route in the Official Plan. High level objectives for the Scenic Routes can be found in 4.6.2(4) of the OP. Deriving from the Official Plan policies, the design of the proposed addition is expected to achieve high quality landscaping and architecture.
  - a. With respect to landscaping, the new development should preserve as much existing trees along Hunt Club Road as possible, and compensate any loss of existing trees with new vegetations.
  - b. The existing pedestrian connection from the Hunt Club Road sidewalk should be maintained and upgraded with enhanced landscaping.
  - c. With respect to architecture, the current building resembles the characteristics of a “business park” building largely invisible from Huntclub Road due to extensive landscaping. The addition will be much closer to Huntclub Road and visible. By virtue of its location and visibility the addition should be envisioned as a modern “urban” office building with attractive design, quality materials and details. There is little to no value to make the new addition architecturally in harmony with the existing building. The new additional should reflect the most current architecture considerations, including high-performance sustainable design, while functionally and structurally connected to the existing building. The Costco HQ in Issaquah Washington may offer as a useful reference.
    - i. The proposed sectional approach to break up the long façade is interesting. Considerations may be given to breaking up the mass into 1-2-1-2-1 as opposed to the currently proposed 2-2-2-1 to give the new visitor entrance some profile.
    - ii. The window pattern on the facades should be carefully considered with details that can live up to the expectation of a modern “urban” office building.
    - iii. Noble and high quality facade materials are expected.
    - iv. The canopy over the visitor entrance should be carefully designed to anchor the entrance. The small windows shown on the west façade is inadequate.

Feel free to contact Randolph Wang, Urban Designer, at [randolph.wang@ottawa.ca](mailto:randolph.wang@ottawa.ca) for follow-up questions.

## **Transportation**

1. Follow the City’s TIA guidelines.
  - a) A TIA is required.
  - b) Start this process asap. The application will not be deemed complete until the submission of the draft step 1-4, including the draft RMA package

- (including functional plan and RMA drawings) and/or monitoring report (if applicable).
- c) Request base mapping asap if RMA is required. Contact Engineering Services (<https://ottawa.ca/en/city-hall/planning-and-development/engineering-services>)
  - d) An update to the *TRANS Trip Generation Manual* has been completed (October 2020). This manual is to be utilized for this TIA. A copy of this document can be provided upon request.
2. The proposed signalized crossing for employees must be addressed in the TIA. Ensure the warrants for a PXO are reviewed. An RMA would be required for the PXO.
  3. TMP includes Transit Priority (Isolated Measures) along Hunt Club (2031 Network Concept) and widening of Hunt Club within the study area (2031 Network Concept).
  4. As the proposed site is commercial, AODA legislation applies.
    - a) Ensure all crosswalks located internally on the site provide a TWSI at the depressed curb, per requirements of the Integrated Accessibility Standards Regulation under the AODA.
    - b) Clearly define accessible parking stalls and ensure they meet AODA standards (include an access aisle next to the parking stall and a pedestrian curb ramp at the end of the access aisle, as required).
    - c) Please consider using the City's Accessibility Design Standards, which provide a summary of AODA requirements. <https://ottawa.ca/en/city-hall/creating-equal-inclusive-and-diverse-city/accessibility-services/accessibility-design-standards-features#accessibility-design-standards>
  5. Construct a sidewalk along Roydon Place frontage.
  6. On site plan:
    - a) Ensure site access meets the City's Private Approach Bylaw.
    - b) Show all details of the roads abutting the site up to and including the opposite curb; include such items as pavement markings, accesses and/or sidewalks.
    - c) Turning movement diagrams required for all accesses showing the largest vehicle to access/egress the site.
    - d) Turning movement diagrams required for internal movements (loading areas, garbage).
    - e) Show all curb radii measurements; ensure that all curb radii are reduced as much as possible and fall within TAC guidelines (Figure 8.5.1).

- f) Show dimensions for site elements (i.e. lane/aisle widths, access width and throat length, parking stalls, sidewalks, pedestrian pathways, etc.)
  - g) Sidewalk is to be continuous across access as per City Specification 7.1.
  - h) Parking stalls at the end of dead-end parking aisles require adequate turning around space
  - i) Grey out any area that will not be impacted by this application.
7. A Noise Impact Study to address roadway noise is recommended due to the development's proximity to West Hunt Club and Roydon Place.

Feel free to contact Josiane Gervais, Transportation Project Manager, at [josiane.gervais@ottawa.ca](mailto:josiane.gervais@ottawa.ca) for follow-up questions.

## **Forestry**

### **Tree Conservation Report requirements:**

1. a Tree Conservation Report (TCR) must be supplied for review along with the suite of other plans/reports required by the City
  - a. an approved TCR is a requirement of Site Plan approval.
  - b. The TCR may be combined with the LP provided all information is supplied
2. Any removal of privately-owned trees 10cm or larger in diameter, or city-owned trees of any diameter requires a tree permit issued under the Tree Protection Bylaw (Bylaw 2020 – 340); the permit will be based on an approved TCR and made available at or near plan approval.
3. The Planning Forester from Planning and Growth Management as well as foresters from Forestry Services will review the submitted TCR
  - a. If tree removal is required, both municipal and privately-owned trees will be addressed in a single permit issued through the Planning Forester
  - b. Compensation may be required for city owned trees – if so, it will need to be paid prior to the release of the tree permit
4. The TCR must contain 2 separate plans:
  - a. Plan/Map 1 - show existing conditions with tree cover information
  - b. Plan/Map 2 - show proposed development with tree cover information
  - c. Please ensure retained trees are shown on the landscape plan
5. the TCR must list all trees on site, as well as off-site trees if the CRZ extends into the developed area, by species, diameter and health condition
6. please identify trees by ownership – private onsite, private on adjoining site, city owned, co-owned (trees on a property line)
7. If trees are to be removed, the TCR must clearly show where they are, and document the reason they cannot be retained
8. All retained trees must be shown, and all retained trees within the area impacted by the development process must be protected as per City guidelines available at [Tree Protection Specification](#) or by searching Ottawa.ca
  - a. the location of tree protection fencing must be shown on the plan
  - b. show the critical root zone of the retained trees

9. the City encourages the retention of healthy trees; if possible, please seek opportunities for retention of trees that will contribute to the design/function of the site.
10. For more information on the process or help with tree retention options, contact Mark Richardson [mark.richardson@ottawa.ca](mailto:mark.richardson@ottawa.ca) or on [City of Ottawa](#)

### **Landscape Plan tree planting requirements:**

For additional information on the following please contact [tracy.smith@Ottawa.ca](mailto:tracy.smith@Ottawa.ca)

#### Minimum Setbacks

- Maintain 1.5m from sidewalk or MUP/cycle track or water service laterals.
- Maintain 2.5m from curb
- Coniferous species require a minimum 4.5m setback from curb, sidewalk or MUP/cycle track/pathway.
- Maintain 7.5m between large growing trees, and 4m between small growing trees. Park or open space planting should consider 10m spacing, except where otherwise approved in naturalization / afforestation areas. Adhere to Ottawa Hydro's planting guidelines (species and setbacks) when planting around overhead primary conductors.

#### Tree specifications

- Minimum stock size: 50mm tree caliper for deciduous, 200cm height for coniferous.
- Maximize the use of large deciduous species wherever possible to maximize future canopy coverage
- Tree planting on city property shall be in accordance with the City of Ottawa's Tree Planting Specification; and include watering and warranty as described in the specification (can be provided by Forestry Services).
- Plant native trees whenever possible
- No root barriers, dead-man anchor systems, or planters are permitted.
- No tree stakes unless necessary (and only 1 on the prevailing winds side of the tree)

#### Hard surface planting

- Curb style planter is highly recommended
- No grates are to be used and if guards are required, City of Ottawa standard (which can be provided) shall be used.
- Trees are to be planted at grade

#### Soil Volume

- Please document on the LP that adequate soil volumes can be met:

Tree Type/Size	Single Tree Soil Volume (m3)	Multiple Tree Soil Volume (m3/tree)
Ornamental	15	9
Columnar	15	9
Small	20	12
Medium	25	15
Large	30	18
Conifer	25	15

- Please note that these soil volumes are not applicable in cases with Sensitive Marine Clay.

#### Sensitive Marine Clay

- Please follow the City's 2017 Tree Planting in Sensitive Marine Clay guidelines

#### Tree Canopy Cover

- The landscape plan shall show how the proposed tree planting will replace and increase canopy cover on the site over time, to support the City's 40% urban forest canopy cover target.
- At a site level, efforts shall be made to provide as much canopy cover as possible, through tree planting and tree retention, with an aim of 40% canopy cover at 40 years, as appropriate.
- Indicate on the plan the projected future canopy cover at 40 years for the site.

Feel free to contact Mark Richardson, Forester, at [mark.richardson@ottawa.ca](mailto:mark.richardson@ottawa.ca) for follow-up questions.

#### **Engineering**

Please note the following information regarding the engineering design submission for the above noted site:

1. The Servicing Study Guidelines for Development Applications are available at the following address: <http://ottawa.ca/en/development-application-review-process-0/servicing-study-guidelines-development-applications>
2. Servicing and site works shall be in accordance with the following documents:
  - Ottawa Sewer Design Guidelines (October 2012)

- Ottawa Design Guidelines – Water Distribution (2010)
  - Geotechnical Investigation and Reporting Guidelines for Development Applications in the City of Ottawa (2007)
  - City of Ottawa Slope Stability Guidelines for Development Applications (revised 2012)
  - City of Ottawa Environmental Noise Control Guidelines (January, 2016)
  - City of Ottawa Park and Pathway Development Manual (2012)
  - City of Ottawa Accessibility Design Standards (2012)
  - Ottawa Standard Tender Documents (latest version)
  - Ontario Provincial Standards for Roads & Public Works (2013)
3. Record drawings and utility plans are also available for purchase from the City (Contact the City's Information Centre by email at [InformationCentre@ottawa.ca](mailto:InformationCentre@ottawa.ca) or by phone at (613) 580-2424 x.44455).
4. The Stormwater Management Criteria, for the subject site, is to be based on the following:
- i. The 5-yr storm event using the IDF information derived from the Meteorological Services of Canada rainfall data, taken from the MacDonald Cartier Airport, collected 1966 to 1997.
  - ii. The pre-development runoff coefficient or a maximum equivalent 'C' of 0.5, whichever is less (§ 8.3.7.3).
  - iii. A calculated time of concentration (Cannot be less than 10 minutes).
  - iv. Flows to the storm sewer in excess of the 5-year storm release rate, up to and including the 100-year storm event, must be detained on site.

Note:

- As discussed during the meeting, this proposal should respect existing SWM for this site. If construction of the addition results in a loss of storage (e.g., removal of super pipe beneath parking lot/drive aisle, loss of surface storage in parking lot/drive aisle, loss of pervious land, etc.), this should be

compensated for in the design of the addition. In absence of existing SWM for site, or insufficient existing SWM not meeting the requirements listed in i – iv above, rooftop of addition to be controlled to the 5-yr pre with  $C = 0.5$ .

- It was mentioned during the meeting that there may be restrictions to rooftop ponding due to the site's proximity to the airport. The site falls within the Secondary Airport Bird Hazard Zone as identified by Transport Canada and supported by the Ottawa MacDonal Cartier International Airport (OMCIA), and as identified in the *Guidelines for SWM Feature Design within and adjacent to the Ottawa Macdonald-Cartier International Airport*. Upon review of the Guidelines, there does not seem to be any recommendations restricting rooftop ponding. Therefore, there shouldn't be an issue with rooftop ponding as part of the SWM strategy for this site.
5. Sanitary to be tied in via existing building internal plumbing. Additional demand to be determined and demonstrated that sufficient capacity exists to support the addition.
  6. Water to be tied in via existing building internal plumbing. New water boundary condition request to be made in order to demonstrate that existing supply is sufficient for new fire and domestic demand. The request must include an aerial picture of the location of the service connection (existing connection to the City main in this case) and the expected loads required by the proposed development, including calculations. Note that boundary request results may indicate the requirement of a redundant connection if the new demands trigger the vulnerable service area requirement. Please provide the following information:
    - i. Location of service
    - ii. Type of development and the amount of fire flow required (as per FUS, 1999).
    - iii. Average daily demand: \_\_\_ l/s.
    - iv. Maximum daily demand: \_\_\_ l/s.
    - v. Maximum hourly daily demand: \_\_\_ l/s.
  7. Phase 1 ESAs and Phase 2 ESAs must conform to clause 4.8.4 of the Official Plan that requires that development applications conform to Ontario Regulation 153/04.



Feel free to contact Justin Armstrong, Infrastructure Project Manager, at [justin.armstrong@ottawa.ca](mailto:justin.armstrong@ottawa.ca) or 613-580-2424, x21746 for follow-up questions.

**Other**

- Plans are to be standard A1 size (594 mm x 841 mm) or Arch D size (609.6 mm x 914.4 mm) sheets, dimensioned in metric and utilizing an appropriate Metric scale (1:200, 1:250, 1:300, 1:400 or 1:500).
- All PDF submitted documents are to be unlocked and flattened.
- A Waste Reduction Workplan Summary is required for the construction project as required by O.Reg. 102/94, being “Waste Audits and Waste Reduction Work Plans” made under the Environmental Protection Act, RSO 1990, c E.19, as amended.
- You are encouraged to contact the Ward Councillor, about the proposal.

Please refer to the links to [Guide to preparing studies and plans](#) and [fees](#) for further information. Additional information is available related to [building permits, development charges, and the Accessibility Design Standards](#). Be aware that other fees and permits may be required, outside of the development review process. You may obtain background drawings by contacting [geoinformation@ottawa.ca](mailto:geoinformation@ottawa.ca).

It is anticipated that, as a result of the *More Homes for Everyone Act, 2022*, for applications for site plan approval and zoning by-law amendments, new processes in respect of pre-application consultation will be in place as of January 1, 2023. The new processes are anticipated to require a multiple phase pre-application consultation approach before an application will be deemed complete. Applicants who have not filed a complete application by the effective date may be required to undertake further pre-application consultation(s) consistent with the provincial changes. The by-laws to be amended include By-law 2009-320, the Pre-Consultation By-law, By-law 2022-239, the planning fees by-law and By-law 2022-254, the Information and Materials for Planning Application By-law. The revisions are anticipated to be before Council in the period after the new Council takes office and the end of the year.

These pre-con comments are valid for one year. If you submit a development application(s) after this time, you may be required to meet for another pre-consultation meeting and/or the submission requirements may change. You are as well encouraged to contact us for a follow-up meeting if the plan/concept will be further refined.

## **GENERAL**

Executive Summary: **N/A**

Date and revision number of report: **Included**

Location map and plan showing municipal address, boundary and layout of proposed development: **Included**

Plan showing site and location of all existing services: **Included**

Development statistics, land use, density, adherence to zoning and Official Plan and reference to applicable watershed and subwatershed plans: **N/A**

Summary of Pre-Application Consultation meetings with City of Ottawa and other approval agencies: **Included**

Confirmation of conformance with higher level studies: **N/A**

Statement of objectives and servicing criteria: **Included**

Identification of existing and proposed infrastructure available in the immediate area: **Included**

Identification of Environmentally Significant Areas, watercourses and Municipal Drains potentially impacted by the proposed development: **N/A**

Concept level master grading plan to confirm existing and proposed grades in the proposed development: **Included**

Identification of potential impacts of proposed piped services on private services on adjacent lands: **N/A**

Proposed phasing of proposed development: **N/A**

Reference to geotechnical studies: **Included**

All preliminary and formal site plan submissions should have the following information:

Metric scale: **Included**

North arrow: **Included**

Key plan: **Included**

Property limits: **Included**

Existing and proposed structures and parking areas: **Included**

Easements, road widenings and right-of-ways: **Included**

Street names: **Included**

## **WATER SERVICING**

Confirmation of conformance with Master Servicing Study: **N/A**

Availability of public infrastructure to service proposed development: **Included**

Identification of system constraints: **Included**

Identification of boundary conditions: **Included**

Confirmation of adequate domestic supply: **Included**

Confirmation of adequate fire flow: **Included**

Check of high pressures: **Included**

Definition of phasing constraints: **N/A**

Address reliability requirements: **N/A**

Check on necessity of a pressure zone boundary modification: **N/A**

Reference to water supply analysis to show that major infrastructure is capable of delivering sufficient water for proposed development: **Included**

Description of proposed water distribution network: **Included**

Description of required off-site infrastructure to service proposed development: **N/A**

Confirmation that water demands are calculated based on the City of Ottawa Water Design Guidelines: **Included**

Provision of a model schematic showing the boundary conditions locations, streets, parcels and building locations: **Included**

## **SANITARY SERVICING**

Summary of proposed design criteria: **Included**

Confirmation of conformance with Master Servicing Study: **N/A**

Consideration of local conditions that may contribute to extraneous flows that are higher than the recommended flows in the City of Ottawa Sewer Design Guidelines: **N/A**

Description of existing sanitary sewer available for discharge of wastewater from proposed development: **Included**

Verification of available capacity in downstream sanitary sewer and/or identification of upgrades necessary to service proposed development: **N/A**

Calculations related to dry-weather and wet-weather flow rates: **Included**

Description of proposed sewer network: **Included**

Discussion of previously identified environmental constraints and impact on servicing: **N/A**

Impacts of proposed development on existing pumping stations or requirements for new pumping station: **N/A**

Forcemain capacity in terms of operational redundancy, surge pressure and maximum flow velocity: **N/A**

Identification and implementation of emergency overflow from sanitary pumping stations in relation to the hydraulic grade line to protect against basement flooding: **N/A**

Special considerations (e.g. contamination, corrosive environment): **N/A**

## **STORMWATER MANAGEMENT & STORM SERVICING**

Description of drainage outlets and downstream constraints: **Included**

Analysis of available capacity in existing public infrastructure: **N/A**

Plan showing subject lands, its surroundings, receiving watercourse, existing drainage pattern and proposed drainage pattern: **Included**

Water quantity control objective: **Included**

Water quality control objective: **Included**

Description of the stormwater management concept: **Included**

Setback from private sewage disposal systems: **N/A**

Watercourse and hazard lands setbacks: **N/A**

Record of pre-consultation with the Ministry of the Environment, Conservation and Parks and the Conservation Authority having jurisdiction on the affected watershed: **N/A**

Confirmation of conformance with Master Servicing Study: **N/A**

Storage requirements and conveyance capacity for minor events (5-year return period) and major events (100-year return period): **Included**

Identification of watercourses within the proposed development and how watercourses will be protected or if necessary altered by the proposed development: **N/A**

Calculation of pre-development and post-development peak flow rates: **Included**

Any proposed diversion of drainage catchment areas from one outlet to another: **N/A**

Proposed minor and major systems: **Included**

If quantity control is not proposed, demonstration that downstream system has adequate capacity for the post-development flows up to and including the 100-year return period storm event: **N/A**

Identification of potential impacts to receiving watercourses: **N/A**

Identification of municipal drains: **N/A**

Description of how the conveyance and storage capacity will be achieved for the proposed development: **Included**

100-year flood levels and major flow routing: **Included**

Inclusion of hydraulic analysis including hydraulic grade line elevations: **N/A**

Description of erosion and sediment control during construction: **Included**

Obtain relevant floodplain information from Conservation Authority: **N/A**

Identification of fill constraints related to floodplain and geotechnical investigation: **N/A**

## **APPROVAL AND PERMIT REQUIREMENTS**

Conservation Authority as the designated approval agency for modification of floodplain, potential impact on fish habitat, proposed works in or adjacent to a watercourse, cut/fill permits and Approval under Lakes and Rivers Improvement Act. The Conservation Authority is not the approval authority for the Lakes and Rivers Improvement Act. Where there are Conservation Authority regulations in place, approval under the Lakes and Rivers Improvement Act is not required, except in cases of dams as defined in the Act: **N/A**

Application for Certificate of Approval (CofA) under the Ontario Water Resources Act: **N/A**

Changes to Municipal Drains: **N/A**

Other permits (e.g. National Capital Commission, Parks Canada, Public Works and Government Services Canada, Ministry of Transportation): **N/A**

## **CONCLUSIONS**

Clearly stated conclusions and recommendations: **Included**

Comments received from review agencies: **N/A**

Signed and stamped by a professional Engineer registered in Ontario: **Included**