

HOMESTEAD LAND HOLDINGS LIMITED

# 210 CLEARVIEW AVENUE REDEVELOPMENT STORMWATER MANAGEMENT REPORT

SEPTEMBER 24, 2024

COPY

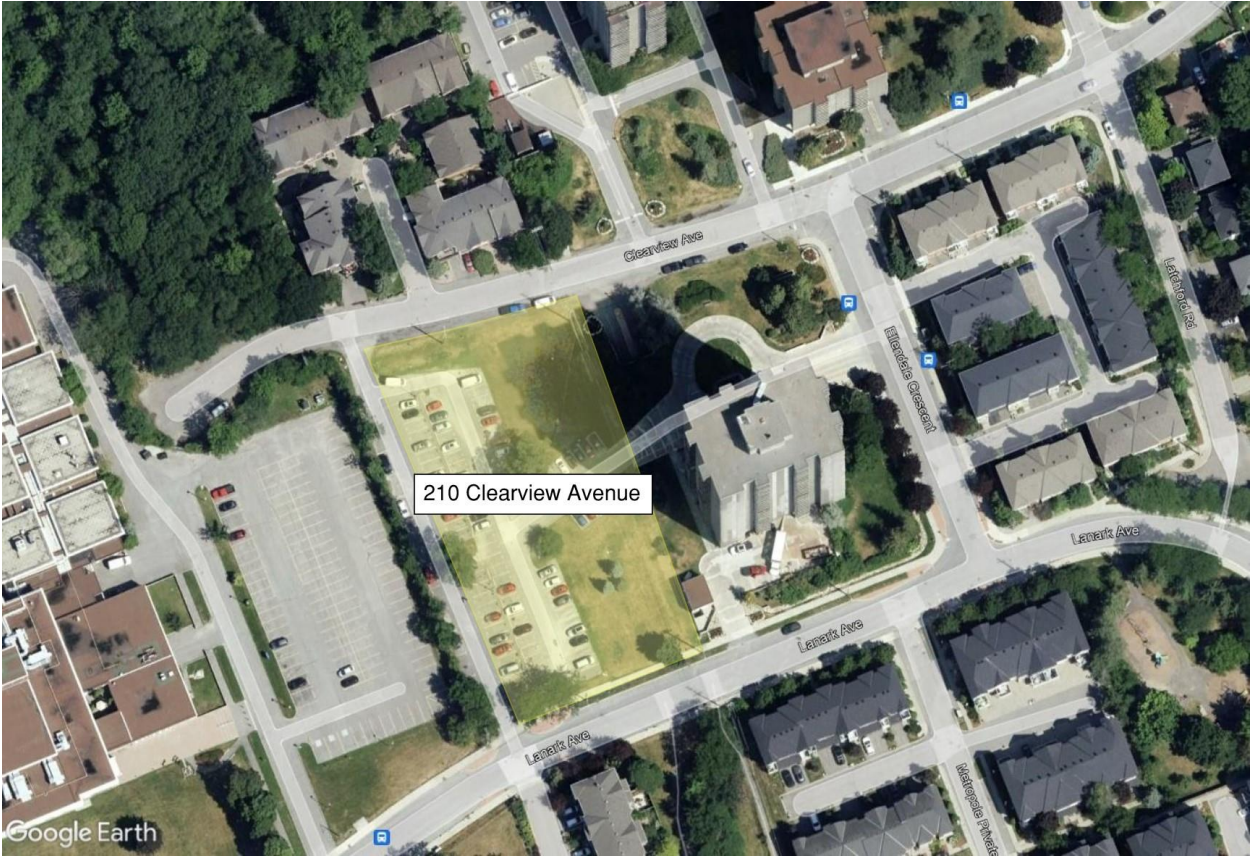



210 CLEARVIEW  
AVENUE  
REDEVELOPMENT  
STORMWATER  
MANAGEMENT REPORT  
HOMESTEAD LAND HOLDINGS LIMITED

COPY

PROJECT NO.: 221-08957-00  
DATE: SEPTEMBER 2024  
VERSION: 01

WSP  
201-1224 GARDINERS ROAD  
KINGSTON, ON  
CANADA K7P 0G2

T: +1 613 634-7373  
F: +1 613 634-3523  
WSP.COM

---

# SIGNATURES

## PREPARED BY

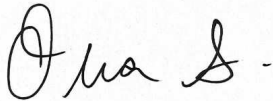

---

Olivia Simpson  
Designer, Kingston

## REVIEWED BY



---

Scott Taylor, P.Eng.  
Senior Civil Engineer, Municipal Engineering – Ottawa



WSP Canada Inc. prepared this report solely for the use of the intended recipient, Homestead Land Holdings Limited, in accordance with the professional services agreement. The intended recipient is solely responsible for the disclosure of any information contained in this report. The content and opinions contained in the present report are based on the observations and/or information available to WSP Canada Inc. at the time of preparation. If a third party makes use of, relies on, or makes decisions in accordance with this report, said third party is solely responsible for such use, reliance or decisions. WSP Canada Inc. does not accept responsibility for damages, if any, suffered by any third party as a result of decisions made or actions taken by said third party based on this report. This limitations statement is considered an integral part of this report.

The original of this digital file will be conserved by WSP Canada Inc. for a period of not less than 10 years. As the digital file transmitted to the intended recipient is no longer under the control of WSP Canada Inc., its integrity cannot be assured. As such, WSP Canada Inc. does not guarantee any modifications made to this digital file subsequent to its transmission to the intended recipient.



# TABLE OF CONTENTS

1	INTRODUCTION.....	1
1.1	SCOPE.....	1
1.2	SITE LOCATION.....	1
1.3	OBJECTIVES.....	2
1.4	DESIGN CRITERIA.....	2
1.4.1	Ministry of Environment, Conservation and Parks (MECP) .....	3
2	PRE-DEVELOPMENT CONDITIONS .....	4
2.1	EXISTING LAND-USE AND DRAINAGE PATTERNS ..	4
2.2	ALLOWABLE Flow Rates .....	4
3	POST-DEVELOPMENT CONDITIONS .....	5
3.1	PROPOSED STORM SYSTEM .....	5
3.2	PEAK FLOW MODELLING .....	5
3.3	QUANTITY CONTROL .....	6
3.4	QUALITY CONTROL .....	6
3.5	DIVERSION OF DRAINAGE CATCHMENT AREAS.....	6
3.6	WATERCOURSES, MUNICIPAL DRAINS, AND FLOODPLAINS.....	6
3.7	SETBACKS FROM SIGNIFICANT FEATURES .....	7
3.8	FILL CONSTRAINT .....	7
4	SEDIMENT AND EROSION CONTROL .....	8
4.1	GENERAL .....	8
5	CONCLUSIONS.....	9

---

## *TABLES*

TABLE 1: CITY OF OTTAWA DESIGN GUIDELINE RUNOFF COEFFICIENTS.....	2
TABLE 2: PRE-DEVELOPMENT PEAK FLOWS .....	4
TABLE 3: ALLOWABLE RELEASE RATE AND POST- DEVELOPMENT PEAK FLOWS FOR A2, A3, AND B1.....	5
TABLE 4: STORAGE RESULTS FOR CATCHMENT A1. .	6

---

## *FIGURES*

FIGURE 1: PROJECT LOCATION (IMAGE SOURCE: GOOGLE EARTH PRO). .....	1
---	---

---

## *APPENDICES*

APPENDIX A – CATCHMENT FIGURES
APPENDIX B – STORMWATER MANAGEMENT CALCULATIONS
APPENDIX C – QUALITY TREATMENT DEVICE
APPENDIX D – CITY CORRESPONDENCE

# 1 INTRODUCTION

---

## 1.1 SCOPE

WSP Canada Inc. (WSP) has been retained to provide civil engineering consulting services to support the Site Plan Approval application for 210 Clearview Avenue Development located in Ottawa, Ontario. This stormwater management (SWM) report examines the potential water quality and quantity impacts of the proposed development and details SWM measures to be provided to address these impacts in accordance with the City of Ottawa Sewer Design Guidelines (2012) and associated Technical Bulletins, Pre-application consultation meeting minutes, and the City of Ottawa Servicing Study Guidelines for Development Applications (2009). Refer to **Servicing Report – Appendix B** for completed City Servicing Report Checklist.

---

## 1.2 SITE LOCATION

The site of the proposed development is located within the City of Ottawa, within the Kitchissippi Ward, as shown in Figure 1. The site to be developed is approximately 0.54 ha (5,437 m<sup>2</sup>) and is bounded by Clearview Avenue (to the north), 200 Clearview Ave (to the east), Lanark Avenue (to the south), and 281 Clearview Ave (to the west).



**Figure 1: Project Location (Image Source: Google Earth Pro).**

---

## 1.3 OBJECTIVES

The objectives of this SWM plan are noted below:

- Determine the site-specific stormwater management requirements for the proposed development, as indicated by associated Provincial, Municipal, and Conservation Authority regulations and guidelines, and pre-consultation with the City of Ottawa.
- In collaboration with the design team and the Developer, develop a strategy to address the SWM criteria on-site. Complete calculations and analyses necessary to determine the required size of the SWM features and demonstrate compliance with the design criteria.
- Prepare a SWM report documenting the above tasks in a manner suitable for review by the City’s development review department.

---

## 1.4 DESIGN CRITERIA

Based on applicable design guidelines and standards and pre-application consultation with the City (Servicing Report - Appendix B), the SWM design criteria for the development have been summarized below:

- Stormwater runoff from all storm events up to and including the 100-year storm (i.e. major storm) will be captured in a cistern and conveyed to the Clearview Avenue storm sewer system at the 2-year pre-development rate.
- All post-development storm events will need to be released at, or below, the pre-development 2-year storm event flow rate to Clearview Avenue.
- The pre-development peak flow rate for the 2-year storm event shall be determined per existing conditions with a runoff coefficient (C) no greater than 0.50. The runoff coefficients are per the City of Ottawa Sewer Design Guidelines.
- The time of concentration will also be calculated for pre- and post-development conditions, with a minimum time of 10 minutes.
- The City of Ottawa has confirmed that the storm infrastructure along Clearview Avenue has sufficient capacity to receive the 2-year pre-development storm event peak flow rate, see **Servicing Report - Appendix A**.
- Maintain at least 15 cm of vertical clearance between the spill elevation on the street and the ground elevation at the building envelope that is in the proximity of the flow route or ponding area.
- The stormwater will need to meet Level 1, enhanced protection (80% TSS removal) per the Ministry of Environment, Conservation and Parks (MECP), refer to **Servicing Report - Appendix A** for City correspondence.

The calculated weighted runoff coefficients for the affected areas under pre- and post-development conditions are displayed in the Pre-Development Catchment Map (SK1) and the Post-Development Catchment Map (SK2) in **Appendix A**. These weighted runoff coefficients were calculated using the City of Ottawa Design Guideline values found in Table 1.

**Table 1: City of Ottawa Design Guideline Runoff Coefficients.**

LAND USE	RUNOFF COEFFICIENT
Asphalt, Concrete, Roof Areas	0.90
Grassed Area	0.20

---

#### *1.4.1 MINISTRY OF ENVIRONMENT, CONSERVATION AND PARKS (MECP)*

As the site is a non-industrial property, an Environmental Compliance Approval (ECA) is not anticipated to be required by the MECP.



# 2 PRE-DEVELOPMENT CONDITIONS

## 2.1 EXISTING LAND-USE AND DRAINAGE PATTERNS

The evaluated project site of 200 and 210 Clearview Avenue is approximately 1.096 ha with 54% of this area consisting of asphalt, concrete, roof, and other impervious surfaces. The remaining 46% is grassed and other pervious surfaces. The resulting weighted runoff coefficient was found to be 0.54, which represents the entirety of the site area. The existing storm water infrastructure near the site is located along Clearview Avenue to the north of the site and Lanark Avenue to the south of the site. The storm water infrastructure along Clearview Avenue consists of a 375 mm diameter concrete storm sewer, while the infrastructure along Lanark Avenue comprises a 900 mm diameter concrete storm sewer. Both storm sewers discharge to the Ottawa River, approximately 1.5 km away, at the north end of Churchill Avenue and Keyworth Avenue to Pontiac Street through an easement, respectively.

Catchment areas A1 and A2 release to Clearview Avenue, catchment area A3 releases to Ellendale Crescent and catchment area B1 releases to Lanark Avenue. No additional controls will be proposed for catchments areas A2, A3 and B1; however, these catchment areas were included in this review to show that there will be no net increase in flow rates at 200 Clearview Avenue.

Refer to **Appendix A** for the pre-development catchment map.

## 2.2 ALLOWABLE FLOW RATES

As noted in Section —, stormwater runoff from all events up to and including the 100-year storm will be controlled to 2-year pre-development rates. For catchment area A1, it was determined that the pre-development runoff coefficient was greater than 0.50, therefore 0.50 was used. IDF parameters are as per the City of Ottawa Sewer Design Guidelines (2012) and shown below:

$$\text{2-year intensity} = 732.951 / (\text{Time in min} + 6.199)^{0.810}$$

$$\text{5-year intensity} = 998.071 / (\text{Time in min} + 6.053)^{0.814}$$

$$\text{100-year intensity} = 1735.688 / (\text{Time in min} + 6.014)^{0.820}$$

Release rates were calculated using the Modified Rational Method. The results for each catchment area can be seen below in Table 2. Release rates matching the 2-year pre-development flow will only be required for catchment area A1 given the proposed development will only release to Clearview Avenue. Detailed calculations can be found in **Appendix B**.

**Table 2: Pre-Development Peak Flows**

Return Period	Catchment A1 Area Flows (L/s)	Catchment A2 Area Flows (L/s)	Catchment A3 Area Flows (L/s)	Catchment B1 Area Flows (L/s)
2-year	36.6	59.1	6.5	7.9
5-year	49.6	80.2	8.9	10.6
100-year	106.2	171.7	19.0	22.7

# 3 POST-DEVELOPMENT CONDITIONS

The proposed development is a new 25-storey multi-residential apartment building with 2-storey underground parking levels. The development will accommodate 184 residential units, including amenity space. At-grade features also include access laneways, vehicle parking, and concrete sidewalks. The resulting imperviousness of the site was calculated to be 56% of this area with the remaining 44% consisting of grassed and other pervious surfaces. The resulting weighted runoff coefficient was found to be 0.59, which represents the entirety of the site area. Catchment B1 will be reduced given the proposed development is contained within catchment A1. Therefore, the post-development peak flows to Lanark Avenue will be reduced. The post-development catchment map is provided in **Appendix A**.

## 3.1 PROPOSED STORM SYSTEM

The proposed system consists of roof and deck drains that direct water to an internal cistern tank located in the below ground parking lot (P1 level). Along the west site of the property, two catch basins will also connect to the building to convey stormwater runoff to the cistern. From the cistern, the stormwater runoff will be pumped to a gravity sewer and will outlet to the 375 mm diameter municipal storm sewer system along Clearview Avenue. The cistern and pump will be designed by the Mechanical Engineer to pump at a fixed release rate (2-year predevelopment flow) to the 375 mm diameter municipal gravity storm sewer system along Clearview Avenue.

The storm sewer that outlets to Clearview Avenue was sized using the 2-year pre-development flow (design flows) and the Manning’s equation (for hydraulics), based on the following criteria:

- Initial Inlet Time of Concentration = 10 mins.
- Pipe Velocities = 0.80 m/s to 6.0 m/s
- Minimum Pipe Size (Diameter) 250 mm (Sewers) & 200mm (CB Leads)

To meet the criteria noted above, the outlet sewer is proposed to be 250mm at 0.6%. Refer to **Servicing Report – Appendix A** for Civil Drawings and **Appendix B** storm sewer sizing calculation sheet.

A control maintenance hole will be installed at the property line prior to discharging to the municipal sewer. Due to limited space, the control structure will be the proposed oil/grit separator (OGS) structure, refer to Section 3.4 for OGS Unit details.

## 3.2 PEAK FLOW MODELLING

The allowable release rates for catchment areas A2, A3, and B1 are set to their corresponding pre-development peak flows. The conditions of 200 Clearview are not being revised, and the flow rates to any stormwater management facilities (if applicable) will remain unchanged. All post-development peak flows are equal to or less than the allowable release rates, as seen in Table 3.

**Table 3: Allowable Release Rate and Post-Development Peak Flows for A2, A3, and B1.**

Return Period	Catchment A2 Area Flows (L/s)		Catchment A3 Area Flows (L/s)		Catchment B1 Area Flows (L/s)	
	Allowable Release Rates	Post-Development	Allowable Release Rates	Post-Development	Allowable Release Rates	Post-Development
2-year	59.1	51.6	6.5	6.5	7.9	2.4
5-year	80.2	70.0	8.9	8.9	10.6	3.3

100-year	171.7	150.0	19	19	22.7	7.0
----------	-------	-------	----	----	------	-----

### 3.3 QUANTITY CONTROL

The allowable release rate for catchment area A1 (210 Clearview site) is equal to the 2-year pre-development peak flow of 36.6 L/s. This release rate was applied to all return periods in order to size the proposed internal cistern storage to retain additional stormwater while releasing at the allowed rate. These values can be found in Table 4. Refer to **Appendix B** for detailed calculations.

**Table 4: Storage Results for Catchment A1.**

Return Period	Allowable Release Rates (L/s)	Post Development Flow (L/s)	Controlled Post Development Peak Storage Outflow (L/s)	Post Development Storage (m <sup>3</sup> )
2-year	<b>36.6</b>	76.5	36.6	<b>24.0</b>
5-year	<b>36.6</b>	103.8	36.6	<b>40.3</b>
100-year	<b>36.6</b>	222.3	36.6	<b>140.0</b>

### 3.4 QUALITY CONTROL

As mentioned in Section 1.4 Design Criteria, the stormwater will need to meet Level 1, enhanced protection (80% TSS removal) per the Ministry of Environment, Conservation and Parks (MECP) Stormwater Management Planning and Design Manual. This requirement will be achieved through a quality treatment device (OGS unit model EF04) located downstream of the cistern prior to outletting to the Clearview Avenue storm sewer. Refer to **Appendix C** for the oil/grit separator sizing sheets.

### 3.5 DIVERSION OF DRAINAGE CATCHMENT AREAS

A portion of pre-development catchment area B1 will be directed to the Clearview Avenue outlet within catchment A1. This will reduce stormwater flows to the Lanark Avenue storm sewers.

### 3.6 WATERCOURSES, MUNICIPAL DRAINS, AND FLOODPLAINS

Stormwater from the proposed development will not be directly discharged to a watercourse. As such, no significant negative impacts are anticipated to downstream receiving watercourses due to proposed quantity and quality control measures.

The storm sewers on Clearview Avenue and Lanark Avenue discharge to the Ottawa River, approximately 1.5km away, at the north end of Churchill Avenue and Keyworth Avenue to Pontiac Street through an easement. No significant negative impacts are anticipated to downstream receiving watercourses due to proposed quantity and quality control measures.

There are no municipal drains on the site or associated with the drainage from the site.

There are no designated floodplains on the site of this development.

---

### 3.7 SETBACKS FROM SIGNIFICANT FEATURES

There are no private sewage disposal systems, watercourses, and/or hazard lands in the vicinity of the subject site. As such, there are no associated set-backs requirements.

---

### 3.8 FILL CONSTRAINT

There are no known fill constraints applicable to this site related to any floodplain. No fill constraints related to soil conditions are anticipated, as confirmed in the geotechnical report.

# 4 SEDIMENT AND EROSION CONTROL

---

## 4.1 GENERAL

During construction, existing storm sewer systems can be exposed to sediment loadings. A number of construction techniques designed to reduce unnecessary construction sediment loadings will be used, including:

- Filter cloths, which will remain on open surface structures such as maintenance holes and catch basins until these structures are commissioned and put into use;
- Installation of silt fence, where applicable, around the perimeter of the proposed work area; and,
- The installation of straw bale barriers within existing drainage features surrounding the site;

During construction of the services, any trench dewatering using pumps will be fitted with a “filter sock”. Thus, any pumped groundwater will be filtered prior to release to the existing surface runoff. The contractor will inspect and maintain the “filter sock” as needed including sediment removal and disposal.

All catch basins, and to a lesser degree, maintenance holes, convey surface water to sewers. Consequently, until the surrounding surface has been completed, these structures will be covered to prevent sediment from entering the minor storm sewer system. These measures will stay in place and be maintained during construction and build-out until it is appropriate to remove them.

During construction of any development both imported and native soils are placed in stockpiles. Mitigative measures and proper management to prevent these materials entering the sewer system are needed. During construction of the deeper water mains and sewers, imported granular bedding materials are temporarily stockpiled on site. These materials are however quickly used up and generally placed before any catch basins are installed. Refer to the Erosion and Sediment Control Plan (drawing C02) provided in **Servicing Report - Appendix A**.

# 5 CONCLUSIONS

WSP has completed this stormwater management analysis, calculations, and reporting in support of the Site Plan Application for the proposed development at 210 Clearview Avenue. Stormwater management requirements for the site have been determined and on-site quantity control infrastructure has been sized. A total storage volume of 140 m<sup>3</sup> will be provided by an internal cistern to restrict flow to the 2-year pre-development flow rate to release to the Clearview Avenue outlet to meet the City of Ottawa SWM criteria.

# **APPENDIX A – CATCHMENT FIGURES**





CATCHMENT CHARACTERISTICS			
	IMPERVIOUS @ C-FACTOR BELOW 0.90	PERVIOUS @ C-FACTOR BELOW 0.20	
CATCHMENT ID	IMPERVIOUS (ha)	PERVIOUS (ha)	TOTAL AREAS (ha)
A1	0.225	0.117	0.342
A2	0.288	0.175	0.463
A3	0.020	0.062	0.083
B1	0.010	0.216	0.226
TOTAL	0.543	0.570	1.113

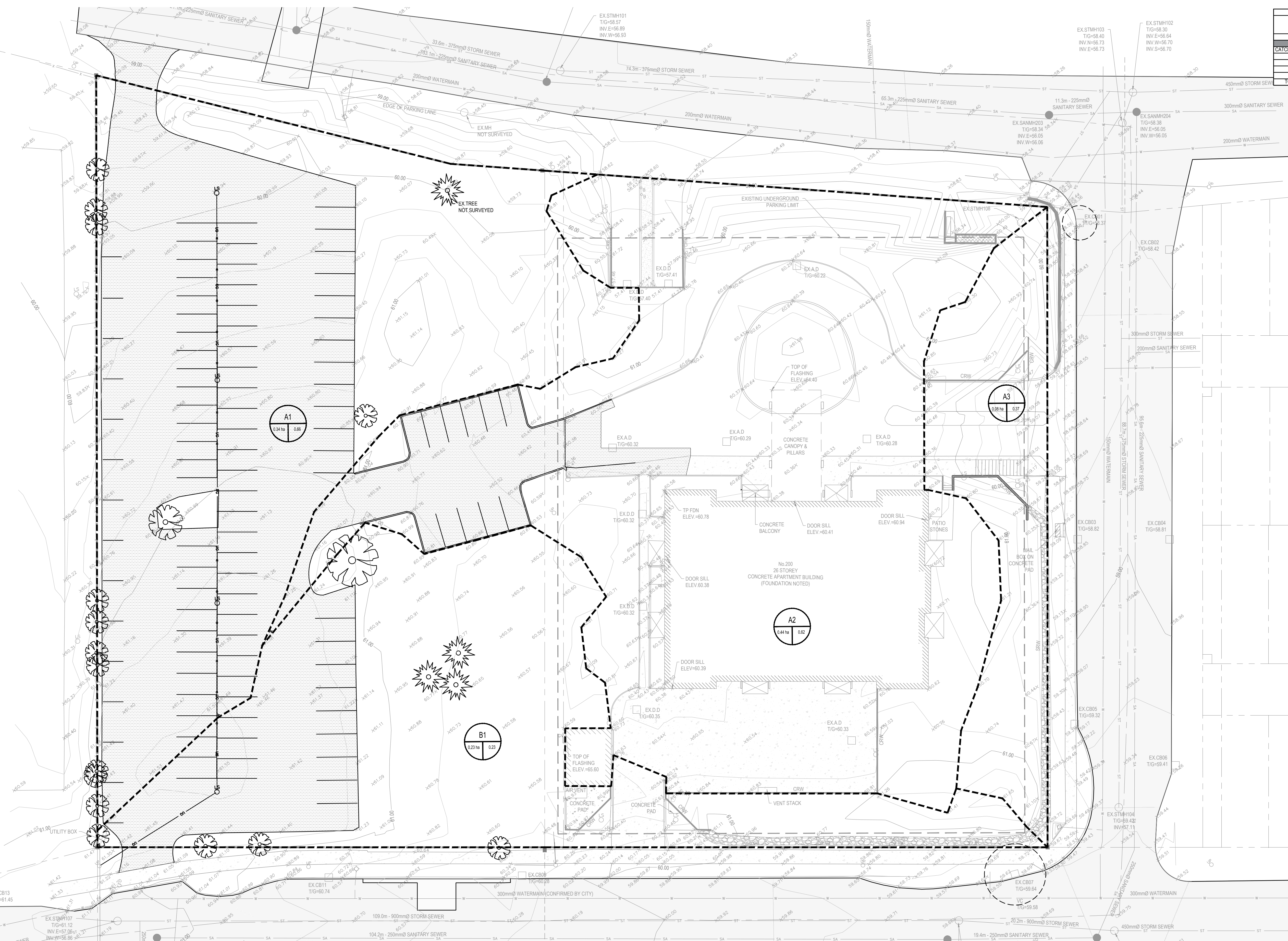

C:\wsp\proj\2024\09\24\210 Clearview Avenue\Drawings\01 - CIVIL - Pre-Development Catchment Map.dwg  
 PLOTTED: 2024-09-24 2:40 PM  
 FILE: m:\2024\210 Clearview Avenue\Drawings\01 - CIVIL - Pre-Development Catchment Map.dwg

REV	DATE	DESCRIPTION	BY
0	2024-09-24	ISSUED FOR SITE PLAN CONTROL - DRAFT	ST



DISCLAIMER: THIS DRAWING AND DESIGN IS COPYRIGHT PROTECTED WHICH SHALL NOT BE USED, REPRODUCED OR REVISED WITHOUT WRITTEN PERMISSION BY WSP. THE CONTRACTOR SHALL CHECK AND VERIFY ALL DIMENSIONS AND UTILITY LOCATIONS AND REPORT ALL ERRORS AND OMISSIONS PRIOR TO COMMENCING WORK.

ORIGINAL SCALE: 1:250  
 DESIGNED BY: M. ST. MARSEILLE  
 DRAWN BY: G. HOOGWERF  
 CHECKED BY: S. TAYLOR  
 DATE: SEPTEMBER 2024  
 IF THIS BAR IS NOT 25mm LONG, ADJUST YOUR PLOTTING SCALE.  
 25mm  
 DISCIPLINE: CIVIL

  
 WSP CANADA INC.  
 1224 GARDINERS ROAD, SUITE 201  
 KINGSTON, ONTARIO  
 CANADA K7P 0G2  
 PHONE: 613-634-7373  
 WWW.WSP.COM  
 PROJECT NUMBER: 221-08957-00

CLIENT:   
 CLIENT REF. #

TITLE: PRE DEVELOPMENT CATCHMENT MAP  
 PROJECT: 210 CLEARVIEW AVENUE  
 DRAWING NUMBER: SK1  
 REV: 0





CATCHMENT ID	CATCHMENT CHARACTERISTICS		TOTAL AREA (ha)	WEIGHTED C-FACTOR
	IMPERVIOUS @ C-FACTOR BELOW 0.80	PERVIOUS @ C-FACTOR BELOW 0.20		
A1	0.345	0.241	0.586	0.61
A2	0.235	0.148	0.384	0.63
A3	0.020	0.062	0.083	0.37
B1	0.011	0.032	0.043	0.38
<b>TOTAL</b>	<b>0.611</b>	<b>0.483</b>	<b>1.094</b>	<b>0.59</b>

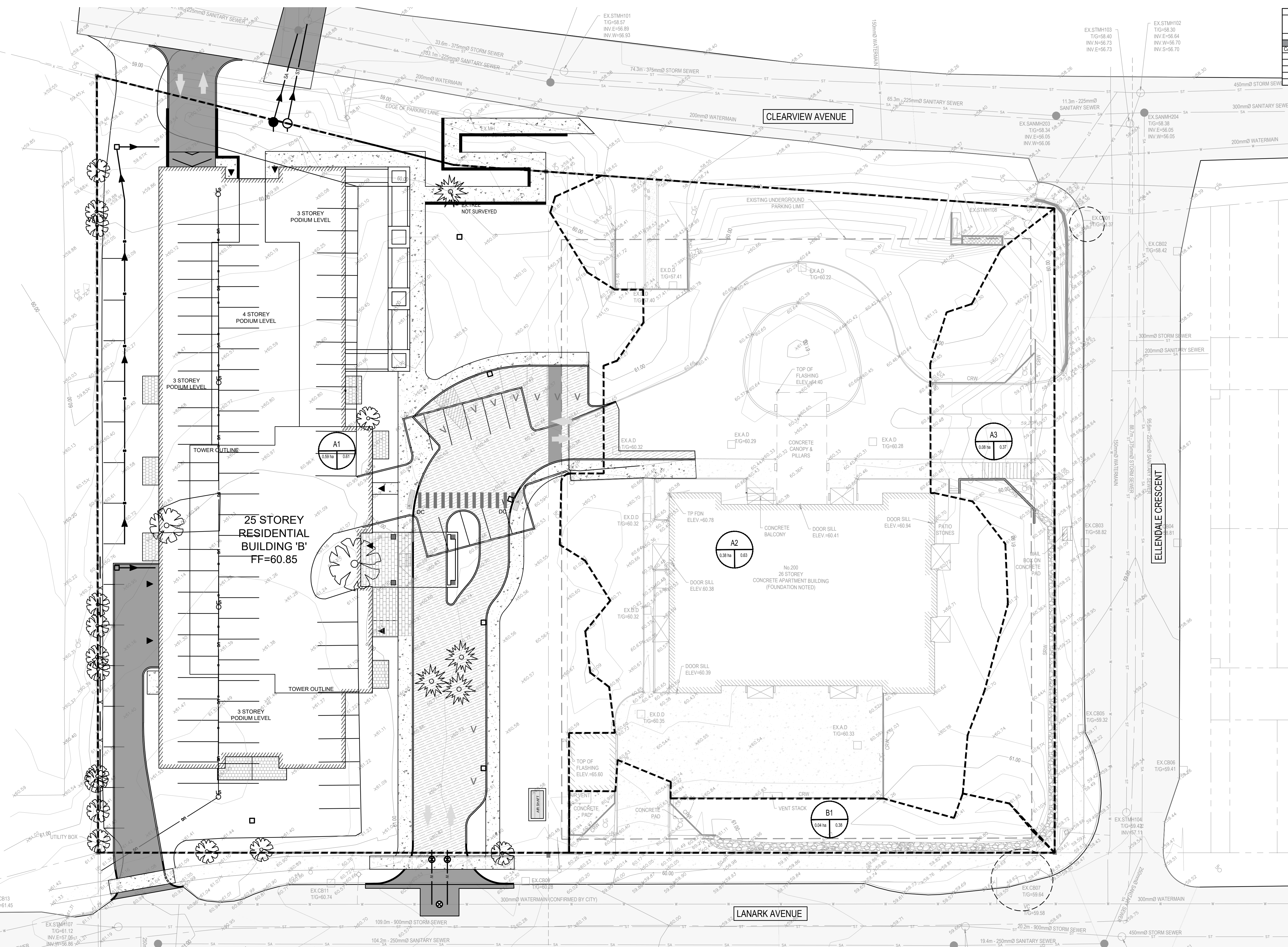

C:\Users\kjohnson\OneDrive\Documents\2024-09-24\210 Clearview Avenue\210 Clearview Avenue.dwg  
 PLOTTED: 2024-09-24 10:03 AM  
 FILE: m:\2022\210-210 Clearview Avenue\210 Clearview Avenue.dwg

REVISION	DATE	DESCRIPTION	BY
0	2024-09-24	ISSUED FOR SITE PLAN CONTROL	ST



DISCLAIMER: THIS DRAWING AND DESIGN IS COPYRIGHT PROTECTED WHICH SHALL NOT BE USED, REPRODUCED OR REVISED WITHOUT WRITTEN PERMISSION BY WSP. THE CONTRACTOR SHALL CHECK AND VERIFY ALL DIMENSIONS AND UTILITY LOCATIONS AND REPORT ALL ERRORS AND OMISSIONS PRIOR TO COMMENCING WORK.

ORIGINAL SCALE: 1:250  
 DESIGNED BY: M. ST. MARSEILLE  
 DRAWN BY: G. HOOGWERF  
 CHECKED BY: S. TAYLOR  
 DATE: SEPTEMBER 2024  
 IF THIS BAR IS NOT 25mm LONG, ADJUST YOUR PLOTTING SCALE.  
 25mm  
 DISCIPLINE: CIVIL

WSP CANADA INC.  
 1224 GARDINERS ROAD, SUITE 201  
 KINGSTON, ONTARIO  
 CANADA K7P 0G2  
 PHONE: 613-634-7373  
 WWW.WSP.COM  
 PROJECT NUMBER: 221-08957-00

CLIENT:   
 CLIENT REF. #

TITLE: POST DEVELOPMENT CATCHMENT MAP  
 PROJECT: 210 CLEARVIEW AVENUE  
 DRAWING NUMBER: SK2  
 REV: 0

# **APPENDIX B – STORMWATER MANAGEMENT CALCULATIONS**

**210 CLEARVIEW AVENUE REDEVELOPMENT**

**PRE-DEVELOPMENT**

<b>AREA</b>	<b>AREA</b>	<b>RUNOFF</b>	
<b>No.</b>	<b>(m<sup>2</sup>)</b>	<b>COEFFICIENT</b>	<b>LAND USE</b>
	2246	0.90	Asphalt, Concrete
	0	0.90	Roof Areas
	1177	0.20	Grassed Area
<b>A1</b>	<b>3424</b>	<b>0.66</b>	
	1858	0.90	Asphalt, Concrete
	829	0.90	Roof Areas
	1746	0.20	Grassed Area
<b>A2</b>	<b>4433</b>	<b>0.62</b>	
	202	0.90	Asphalt, Concrete
	0	0.90	Roof Areas
	623	0.20	Grassed Area
<b>A3</b>	<b>825</b>	<b>0.37</b>	
	109	0.90	Asphalt, Concrete
	0	0.90	Roof Areas
	2166	0.20	Grassed Area
<b>B1</b>	<b>2275</b>	<b>0.23</b>	

**POST-DEVELOPMENT**

<b>AREA</b>	<b>AREA</b>	<b>RUNOFF</b>	
<b>No.</b>	<b>(m<sup>2</sup>)</b>	<b>COEFFICIENT</b>	<b>LAND USE</b>
	1496	0.90	Asphalt, Concrete
	1947	0.90	Roof Areas
	2418	0.20	Grassed Area
<b>A1</b>	<b>5861</b>	<b>0.61</b>	
	1527	0.90	Asphalt, Concrete
	829	0.90	Roof Areas
	1484	0.20	Grassed Area
<b>A2</b>	<b>3840</b>	<b>0.63</b>	
	202	0.90	Asphalt, Concrete
	0	0.90	Roof Areas
	623	0.20	Grassed Area
<b>A3</b>	<b>825</b>	<b>0.37</b>	
	109	0.90	Asphalt, Concrete
	0	0.90	Roof Areas
	323	0.20	Grassed Area
<b>B1</b>	<b>432</b>	<b>0.38</b>	

**210 CLEARVIEW AVENUE REDEVELOPMENT  
OUTLET 1 (CLEARVIEW/ELLENDALE)**

**PRE-DEVELOPMENT**

AREA No.	AREA (ha)	RUNOFF COEFFICIENT		TIME OF CONCENTRATION Tc (min)*	RAINFALL INTENSITY I (mm/hr)			PRE-DEVELOPMENT PEAK FLOW Q (L/s)		
		2/5 year	100 year		2 year	5 year	100 year	2 year	5 year	100 year
		A1	0.34		0.50	0.63	10	76.8	104.2	178.6
A2	0.44	0.62	0.78	10	76.8	104.2	178.6	59.1	80.2	171.7
A3	0.08	0.37	0.46	10	76.8	104.2	178.6	6.5	8.9	19.0
<b>Total =</b>	<b>0.87</b>	<b>0.55</b>	<b>0.69</b>		<b>Total Pre-Development Flow: Q =</b>			<b>102.2</b>	<b>138.6</b>	<b>296.9</b>

<b>ALLOWABLE POST-DEVELOPMENT FLOW FOR 1:2 YEAR STORM</b>	
Total Pre-Development Flows (A1)	36.6
Total Post-Development Flows (A1)	76.5
Total Uncontrolled Post-Development Flow	0.0
Maximum Allowable Release From Proposed Site (A1)	<b>36.6</b>

**POST-DEVELOPMENT**

AREA No.	AREA (ha)	RUNOFF COEFFICIENT		TIME OF CONCENTRATION Tc (min)*	RAINFALL INTENSITY I (mm/hr)			POST-DEVELOPMENT PEAK FLOW Q (L/s)		
		2/5 year	100 year		2 year	5 year	100 year	2 year	5 year	100 year
		A1	0.59		0.61	0.76	10	76.8	104.2	178.6
A2	0.38	0.63	0.79	10	76.8	104.2	178.6	51.6	70.0	150.0
A3	0.08	0.37	0.46	10	76.8	104.2	178.6	6.5	8.9	19.0
<b>Total =</b>	<b>1.05</b>	<b>0.60</b>	<b>0.75</b>		<b>Total Post-Development Flow: Q =</b>			<b>134.6</b>	<b>182.6</b>	<b>391.2</b>

<b>ALLOWABLE POST-DEVELOPMENT FLOW FOR 1:5 YEAR STORM</b>	
Total Pre-Development Flows (A1)	49.6
Total Post-Development Flows (A1)	103.8
Total Uncontrolled Post-Development Flow	0.0
Maximum Allowable Release From Proposed Site (A1)	<b>36.6</b>

<b>ALLOWABLE POST-DEVELOPMENT FLOW FOR 1:100 YEAR STORM</b>	
Total Pre-Development Flows (A1)	106.2
Total Post-Development Flows (A1)	222.3
Total Uncontrolled Post-Development Flow	0.0
Maximum Allowable Release From Proposed Site (A1)	<b>36.6</b>

**FORMULAS:**

Weighted runoff coefficient ; c =  $\frac{A_1c_1 + A_2c_2...}{A_1 + A_2...}$

Time of Concentration ; Tc (min) =  
Bransby Williams Formula  
(where c is greater than 0.40)  $\frac{0.057 \times L}{(Sw^{0.2} \times A^{0.1})}$   
L: Length of Watershed (m)  
Sw: Watershed Slope (%)  
A: Watershed Area (ha)

\*Minimum time of concentration = 10 min City of Ottawa Sewer Design Guidelines (2012)

Airport Formula  
(where c is less than 0.40)  $\frac{3.26 \times (1.1 - c) \times L^{0.5}}{Sw^{0.33}}$   
c: Weighted Runoff Coefficient  
L: Length of Watershed (m)  
Sw: Watershed Slope (%)

Rainfall Intensity ; i (mm/hr) =  $\frac{A}{(Tc + C)B}$   
2-yr:  $732.951/(Tc + 6.199)^{0.810}$   
5-yr:  $998.071/(Tc + 6.053)^{0.814}$   
100-yr:  $1735.688/(Tc + 6.014)^{0.820}$

Peak Flow ; Q (l/s) = (2.78) x (ciA)  
c: Weighted Runoff Coefficient  
i: Rainfall Intensity (mm/hr)  
A: Drainage Area (hectares)

**210 CLEARVIEW AVENUE REDEVELOPMENT  
OUTLET 2 (LANARK AVENUE)**

**PRE-DEVELOPMENT**

AREA No.	AREA (ha)	RUNOFF COEFFICIENT		TIME OF CONCENTRATION Tc (min)*	RAINFALL INTENSITY I (mm/hr)			PRE-DEVELOPMENT PEAK FLOW Q (L/s)		
		2/5 year	100 year		2 year	5 year	100 year	2 year	5 year	100 year
B1	0.23	0.23	0.29	19	53.3	72.0	123.0	7.9	10.6	22.7
<b>Total =</b>	<b>0.23</b>	<b>0.23</b>	<b>0.29</b>		<b>Total Pre-Development Flow: Q =</b>			<b>7.9</b>	<b>10.6</b>	<b>22.7</b>

<b>ALLOWABLE POST-DEVELOPMENT FLOW FOR 1:2 YEAR STORM</b>	
Total Pre-Development Flows	7.9
Total Post-Development Flows	2.4
Total Uncontrolled Post-Development Flow	0.0
Maximum Allowable Release From Area	<b>7.9</b>

<b>ALLOWABLE POST-DEVELOPMENT FLOW FOR 1:5 YEAR STORM</b>	
Total Pre-Development Flows	10.6
Total Post-Development Flows	3.3
Total Uncontrolled Post-Development Flow	0.0
Maximum Allowable Release From Area	<b>10.6</b>

**POST-DEVELOPMENT**

AREA No.	AREA (ha)	RUNOFF COEFFICIENT		TIME OF CONCENTRATION Tc (min)*	RAINFALL INTENSITY I (mm/hr)			POST-DEVELOPMENT PEAK FLOW Q (L/s)		
		2/5 year	100 year		2 year	5 year	100 year	2 year	5 year	100 year
B1	0.04	0.38	0.47	19	53.3	72.0	123.0	2.4	3.3	7.0
<b>Total =</b>	<b>0.04</b>	<b>0.38</b>	<b>0.47</b>		<b>Total Post-Development Flow: Q =</b>			<b>2.4</b>	<b>3.3</b>	<b>7.0</b>

<b>ALLOWABLE POST-DEVELOPMENT FLOW FOR 1:100 YEAR STORM</b>	
Total Pre-Development Flows	22.7
Total Post-Development Flows	7.0
Total Uncontrolled Post-Development Flow	0.0
Maximum Allowable Release From Area	<b>10.6</b>

**FORMULAS:**

Weighted runoff coefficient ; c =  $\frac{A_1c_1 + A_2c_2...}{A_1 + A_2...}$

Time of Concentration ; Tc (min) =  
Bransby Williams Formula  
(where c is greater than 0.40)  $\frac{0.057 \times L}{(Sw^{0.2} \times A^{0.1})}$   
L: Length of Watershed (m)  
Sw: Watershed Slope (%)  
A: Watershed Area (ha)

\*Minimum time of concentration = 10 min City of Ottawa Sewer Design Guidelines (2012)

Airport Formula  
(where c is less than 0.40)  $\frac{3.26 \times (1.1 - c) \times L^{0.5}}{Sw^{0.33}}$   
c: Weighted Runoff Coefficient  
L: Length of Watershed (m)  
Sw: Watershed Slope (%)

Rainfall Intensity ; i (mm/hr) =  $\frac{A}{(Tc + C)B}$   
2-yr: 732.951/(Tc + 6.199)<sup>0.810</sup>  
5-yr: 998.071/(Tc + 6.053)<sup>0.814</sup>  
100-yr: 1735.688/(Tc + 6.014)<sup>0.820</sup>  
A, B, C Values from City of Ottawa Sewer Design Guidelines

Peak Flow ; Q (l/s) = (2.78) x (ciA)  
c: Weighted Runoff Coefficient  
i: Rainfall Intensity (mm/hr)  
A: Drainage Area (hectares)

**210 CLEARVIEW AVENUE REDEVELOPMENT**  
**STORMWATER MANAGEMENT VOLUME CALCULATIONS**  
**2 YEAR STORM EVENT**  
**CLEARVIEW AVENUE (A1)**

**PRE-DEVELOPMENT CONDITIONS**

**Area (A) = 0.34 ha**  
**Average Runoff Coefficient (C) = 0.50**  
  
**Release Rate (Q<sub>2</sub>) = 36.6 L/s**

**POST-DEVELOPMENT CONDITIONS (2 YEAR)**

**Drainage Area A (A) = 0.59 ha**  
**Average Runoff Coefficient (C) = 0.61**  
**A 732.951**  
**B 0.810**  
**C 6.199**  
  
**Intensity (I) =  $A/(Tc+C)^B$**   
**Time Interval = 10 mins**

T <sub>c</sub>	Post-Development					
	i <sub>(2)</sub>	Peak Flow (L/s)	Release Rate (L/s)	Storage Rate (L/s)	V <sub>required</sub> (m <sup>3</sup> )	
0	167.22	166.5	36.6	130.0	0.0	
10	76.81	76.5	36.6	<b>39.9</b>	24.0	<b>V<sub>2</sub></b>
20	52.03	51.8	36.6	<b>15.3</b>	18.3	
30	40.04	39.9	36.6	<b>3.3</b>	6.0	
40	32.86	32.7	36.6	<b>-3.8</b>	-9.2	
50	28.04	27.9	36.6	<b>-8.6</b>	-25.9	
60	24.56	24.5	36.6	<b>-12.1</b>	-43.5	
70	21.91	21.8	36.6	<b>-14.7</b>	-61.9	
80	19.83	19.7	36.6	<b>-16.8</b>	-80.7	
90	18.14	18.1	36.6	<b>-18.5</b>	-99.8	
100	16.75	16.7	36.6	<b>-19.9</b>	-119.2	
110	15.57	15.5	36.6	<b>-21.0</b>	-138.9	
120	14.56	14.5	36.6	<b>-22.0</b>	-158.8	
130	13.69	13.6	36.6	<b>-22.9</b>	-178.8	
140	12.93	12.9	36.6	<b>-23.7</b>	-198.9	
150	12.25	12.2	36.6	<b>-24.4</b>	-219.2	

24.0      **MAXIMUM**

**Notes**

- 1) Peak flow is equal to  $2.78 \times C \times I \times A$
- 2) Intensity,  $I = A/(Tc+C)^B$
- 3) Release Rate = Allowable Release Rate (Pre-Development)
- 4) Storage Rate = Peak Flow - Release Rate
- 5) Storage = Time x Storage Rate
- 6) Maximum Storage = Max Storage Over Time

**210 CLEARVIEW AVENUE REDEVELOPMENT**  
**STORMWATER MANAGEMENT VOLUME CALCULATIONS**  
**5 YEAR STORM EVENT**  
**CLEARVIEW AVENUE (A1)**

**PRE-DEVELOPMENT CONDITIONS**

**Area (A) = 0.34 ha**  
**Average Runoff Coefficient (C) = 0.50**  
  
**Release Rate (Q<sub>2</sub>) = 36.6 L/s**

**POST-DEVELOPMENT CONDITIONS (5 YEAR)**

**Drainage Area A (A) = 0.59 ha**  
**Average Runoff Coefficient (C) = 0.61**  
**A 998.071**  
**B 0.814**  
**C 6.053**  
**Intensity (I) = A/(Tc+C)<sup>B</sup>**  
**Time Interval = 10 mins**

T <sub>c</sub>	Post-Development					
	i <sub>(2)</sub>	Peak Flow (L/s)	Release Rate (L/s)	Storage Rate (L/s)	V <sub>required</sub> (m <sup>3</sup> )	
0	230.48	229.5	36.6	193.0	0.0	
10	104.19	103.8	36.6	<b>67.2</b>	40.3	<b>V<sub>5</sub></b>
20	70.25	70.0	36.6	<b>33.4</b>	40.1	
30	53.93	53.7	36.6	<b>17.2</b>	30.9	
40	44.18	44.0	36.6	<b>7.4</b>	17.9	
50	37.65	37.5	36.6	<b>0.9</b>	2.8	
60	32.94	32.8	36.6	<b>-3.7</b>	-13.5	
70	29.37	29.2	36.6	<b>-7.3</b>	-30.7	
80	26.56	26.5	36.6	<b>-10.1</b>	-48.5	
90	24.29	24.2	36.6	<b>-12.4</b>	-66.8	
100	22.41	22.3	36.6	<b>-14.2</b>	-85.4	
110	20.82	20.7	36.6	<b>-15.8</b>	-104.4	
120	19.47	19.4	36.6	<b>-17.2</b>	-123.6	
130	18.29	18.2	36.6	<b>-18.3</b>	-143.0	
140	17.27	17.2	36.6	<b>-19.4</b>	-162.6	
150	16.36	16.3	36.6	<b>-20.3</b>	-182.3	

40.3      **MAXIMUM**

**Notes**

- 1) Peak flow is equal to 2.78 x C x I x A
- 2) Intensity, I = A/(Tc+C)<sup>B</sup>
- 3) Release Rate = Allowable Release Rate (Pre-Development)
- 4) Storage Rate = Peak Flow - Release Rate
- 5) Storage = Time x Storage Rate
- 6) Maximum Storage = Max Storage Over Time

**210 CLEARVIEW AVENUE REDEVELOPMENT**  
**STORMWATER MANAGEMENT VOLUME CALCULATIONS**  
**100 YEAR STORM EVENT**  
**CLEARVIEW AVENUE (A1)**

**PRE-DEVELOPMENT CONDITIONS**

**Area (A) = 0.34 ha**  
**Average Runoff Coefficient (C) = 0.50**  
  
**Release Rate (Q<sub>2</sub>) = 36.6 L/s**

**POST-DEVELOPMENT CONDITIONS (100 YEAR)**

**Drainage Area A (A) = 0.59 ha**  
**Average Runoff Coefficient (C) = 0.76**  
**A 1735.688**  
**B 0.820**  
**C 6.014**  
**Intensity (I) = A/(Tc+C)<sup>B</sup>**  
**Time Interval = 10 mins**

T <sub>c</sub>	Post-Development					
	i <sub>(100)</sub>	Peak Flow (L/s)	Release Rate (L/s)	Storage Rate (L/s)	V <sub>required</sub> (m <sup>3</sup> )	
0	398.62	496.2	36.6	459.6	0.0	
10	178.56	222.3	36.6	<b>185.7</b>	111.4	
20	119.95	149.3	36.6	<b>112.8</b>	135.3	
30	91.87	114.4	36.6	<b>77.8</b>	140.0	<b>V<sub>100</sub></b>
40	75.15	93.5	36.6	<b>57.0</b>	136.8	
50	63.95	79.6	36.6	<b>43.1</b>	129.2	
60	55.89	69.6	36.6	<b>33.0</b>	118.9	
70	49.79	62.0	36.6	<b>25.4</b>	106.8	
80	44.99	56.0	36.6	<b>19.5</b>	93.4	
90	41.11	51.2	36.6	<b>14.6</b>	79.0	
100	37.90	47.2	36.6	<b>10.6</b>	63.8	
110	35.20	43.8	36.6	<b>7.3</b>	48.0	
120	32.89	40.9	36.6	<b>4.4</b>	31.7	
130	30.90	38.5	36.6	<b>1.9</b>	14.9	
140	29.15	36.3	36.6	<b>-0.3</b>	-2.2	
150	27.61	34.4	36.6	<b>-2.2</b>	-19.6	

140.0      **MAXIMUM**

**Notes**

- 1) Peak flow is equal to 2.78 x C x I x A
- 2) Intensity, I = A/(Tc+C)<sup>B</sup>
- 3) Release Rate = Allowable Release Rate (Pre-Development)
- 4) Storage Rate = Peak Flow - Release Rate
- 5) Storage = Time x Storage Rate
- 6) Maximum Storage = Max Storage Over Time



## STORM SEWER CAPACITY CALCULATIONS - 210 Clearview

DATE: August 28, 2024

CALCULATED BY: Marina St. Marseille, EIT

PROJECT NO. 221-08957-00

CHECKED BY: Scott Taylor, P.Eng.

DRAINAGE AREA			RUNOFF DATA			PIPE DATA				
FROM No.	TO No.	AREA DESCRIPTION	AREA (ha)	RUNOFF COEFFICIENT, C	PEAK RUNOFF, Q (L/s)	SIZE (mm)	SLOPE (%)	CAPACITY (L/sec)	Q/Q <sub>full</sub>	VELOCITY (m/sec)
CISTERN	CLEARVIEW AVENUE	A1	0.59	0.32	36.6	250	0.60%	46.1	79%	0.94

**Notes and Constant Values:**

Manning's n = 0.013 City of Ottawa Design Guidelines Table 6.3 (October 2012)

The peak runoff was taken as the allowable release rate to Clearview Avenue (2-yr pre-development flow)

# **APPENDIX C – QUALITY TREATMENT DEVICE**



## Stormceptor® EF Sizing Report

### Imbrium® Systems

#### ESTIMATED NET ANNUAL SEDIMENT (TSS) LOAD REDUCTION

08/26/2024

Province:	Ontario
City:	Ottawa
Nearest Rainfall Station:	OTTAWA CDA RCS
Climate Station Id:	6105978
Years of Rainfall Data:	20

Project Name:	210 Clearview
Project Number:	65524
Designer Name:	Marina St-Marseille
Designer Company:	WSP Canada
Designer Email:	marina.stmarseille@wsp.com
Designer Phone:	613-856-0341
EOR Name:	
EOR Company:	
EOR Email:	
EOR Phone:	

Site Name:

Drainage Area (ha): **0.59**

Runoff Coefficient 'c': **0.61**

Particle Size Distribution: **Fine**

Target TSS Removal (%): **80.0**

Required Water Quality Runoff Volume Capture (%):	90.00
Estimated Water Quality Flow Rate (L/s):	11.62
Oil / Fuel Spill Risk Site?	Yes
Upstream Flow Control?	Yes
Upstream Orifice Control Flow Rate to Stormceptor (L/s):	3.60
Peak Conveyance (maximum) Flow Rate (L/s):	
Influent TSS Concentration (mg/L):	200
Estimated Average Annual Sediment Load (kg/yr):	348
Estimated Average Annual Sediment Volume (L/yr):	283

Net Annual Sediment (TSS) Load Reduction Sizing Summary	
Stormceptor Model	TSS Removal Provided (%)
<b>EFO4</b>	<b>91</b>
EFO6	99
EFO8	100
EFO10	100
EFO12	100

**Recommended Stormceptor EFO Model: EFO4**

**Estimated Net Annual Sediment (TSS) Load Reduction (%): 91**

**Water Quality Runoff Volume Capture (%): > 90**



## THIRD-PARTY TESTING AND VERIFICATION

► **Stormceptor® EF and Stormceptor® EFO** are the latest evolutions in the Stormceptor® oil-grit separator (OGS) technology series, and are designed to remove a wide variety of pollutants from stormwater and snowmelt runoff. These technologies have been third-party tested in accordance with the Canadian ETV **Procedure for Laboratory Testing of Oil-Grit Separators** and performance has been third-party verified in accordance with the **ISO 14034 Environmental Technology Verification (ETV)** protocol.

## PERFORMANCE

► **Stormceptor® EF and EFO** remove stormwater pollutants through gravity separation and floatation, and feature a patent-pending design that generates positive removal of total suspended solids (TSS) throughout each storm event, including high-intensity storms. Captured pollutants include sediment, free oils, and sediment-bound pollutants such as nutrients, heavy metals, and petroleum hydrocarbons. Stormceptor is sized to remove a high level of TSS from the frequent rainfall events that contribute the vast majority of annual runoff volume and pollutant load. The technology incorporates an internal bypass to convey excessive stormwater flows from high-intensity storms through the device without resuspension and washout (scour) of previously captured pollutants. Proper routine maintenance ensures high pollutant removal performance and protection of downstream waterways.

## PARTICLE SIZE DISTRIBUTION (PSD)

► The **Canadian ETV PSD** shown in the table below was used, or in part, for this sizing. This is the identical PSD that is referenced in the Canadian ETV **Procedure for Laboratory Testing of Oil-Grit Separators** for both sediment removal testing and scour testing. The Canadian ETV PSD contains a wide range of particle sizes in the sand and silt fractions, and is considered reasonably representative of the particle size fractions found in typical urban stormwater runoff.

Particle Size (µm)	Percent Less Than	Particle Size Fraction (µm)	Percent
1000	100	500-1000	5
500	95	250-500	5
250	90	150-250	15
150	75	100-150	15
100	60	75-100	10
75	50	50-75	5
50	45	20-50	10
20	35	8-20	15
8	20	5-8	10
5	10	2-5	5
2	5	<2	5

## Stormceptor® EF Sizing Report

### Upstream Flow Controlled Results

Rainfall Intensity (mm / hr)	Percent Rainfall Volume (%)	Cumulative Rainfall Volume (%)	Flow Rate (L/s)	Flow Rate (L/min)	Surface Loading Rate (L/min/m²)	Removal Efficiency (%)	Incremental Removal (%)	Cumulative Removal (%)
0.50	8.6	8.6	0.50	30.0	25.0	100	8.6	8.6
1.00	20.3	29.0	1.00	60.0	50.0	100	20.3	29.0
2.00	16.2	45.2	2.00	120.0	100.0	96	15.6	44.5
3.00	12.0	57.2	3.00	180.0	150.0	89	10.7	55.3
4.00	42.8	100.0	4.00	240.0	200.0	83	35.6	90.8
5.00	0.0	100.0	4.00	240.0	200.0	83	0.0	90.8
6.00	0.0	100.0	4.00	240.0	200.0	83	0.0	90.8
7.00	0.0	100.0	4.00	240.0	200.0	83	0.0	90.8
8.00	0.0	100.0	4.00	240.0	200.0	83	0.0	90.8
9.00	0.0	100.0	4.00	240.0	200.0	83	0.0	90.8
10.00	0.0	100.0	4.00	240.0	200.0	83	0.0	90.8
11.00	0.0	100.0	4.00	240.0	200.0	83	0.0	90.8
12.00	0.0	100.0	4.00	240.0	200.0	83	0.0	90.8
13.00	0.0	100.0	4.00	240.0	200.0	83	0.0	90.8
14.00	0.0	100.0	4.00	240.0	200.0	83	0.0	90.8
15.00	0.0	100.0	4.00	240.0	200.0	83	0.0	90.8
16.00	0.0	100.0	4.00	240.0	200.0	83	0.0	90.8
17.00	0.0	100.0	4.00	240.0	200.0	83	0.0	90.8
18.00	0.0	100.0	4.00	240.0	200.0	83	0.0	90.8
19.00	0.0	100.0	4.00	240.0	200.0	83	0.0	90.8
20.00	0.0	100.0	4.00	240.0	200.0	83	0.0	90.8
21.00	0.0	100.0	4.00	240.0	200.0	83	0.0	90.8
22.00	0.0	100.0	4.00	240.0	200.0	83	0.0	90.8
23.00	0.0	100.0	4.00	240.0	200.0	83	0.0	90.8
24.00	0.0	100.0	4.00	240.0	200.0	83	0.0	90.8
25.00	0.0	100.0	4.00	240.0	200.0	83	0.0	90.8
30.00	0.0	100.0	4.00	240.0	200.0	83	0.0	90.8
35.00	0.0	100.0	4.00	240.0	200.0	83	0.0	90.8
40.00	0.0	100.0	4.00	240.0	200.0	83	0.0	90.8
45.00	0.0	100.0	4.00	240.0	200.0	83	0.0	90.8
<b>Estimated Net Annual Sediment (TSS) Load Reduction =</b>								<b>91 %</b>

Climate Station ID: 6105978 Years of Rainfall Data: 20

## Stormceptor® EF Sizing Report

### RAINFALL DATA FROM OTTAWA CDA RCS RAINFALL STATION

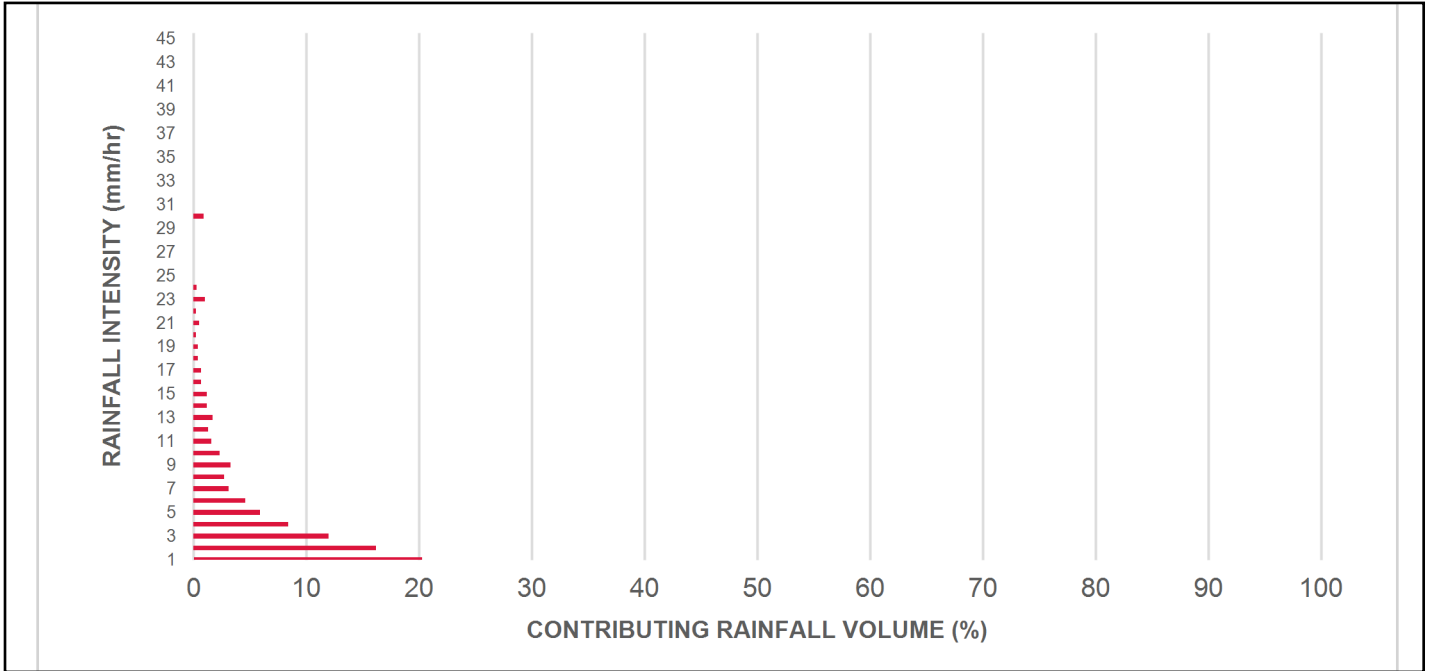

### INCREMENTAL AND CUMULATIVE TSS REMOVAL FOR THE RECOMMENDED STORMCEPTOR® MODEL

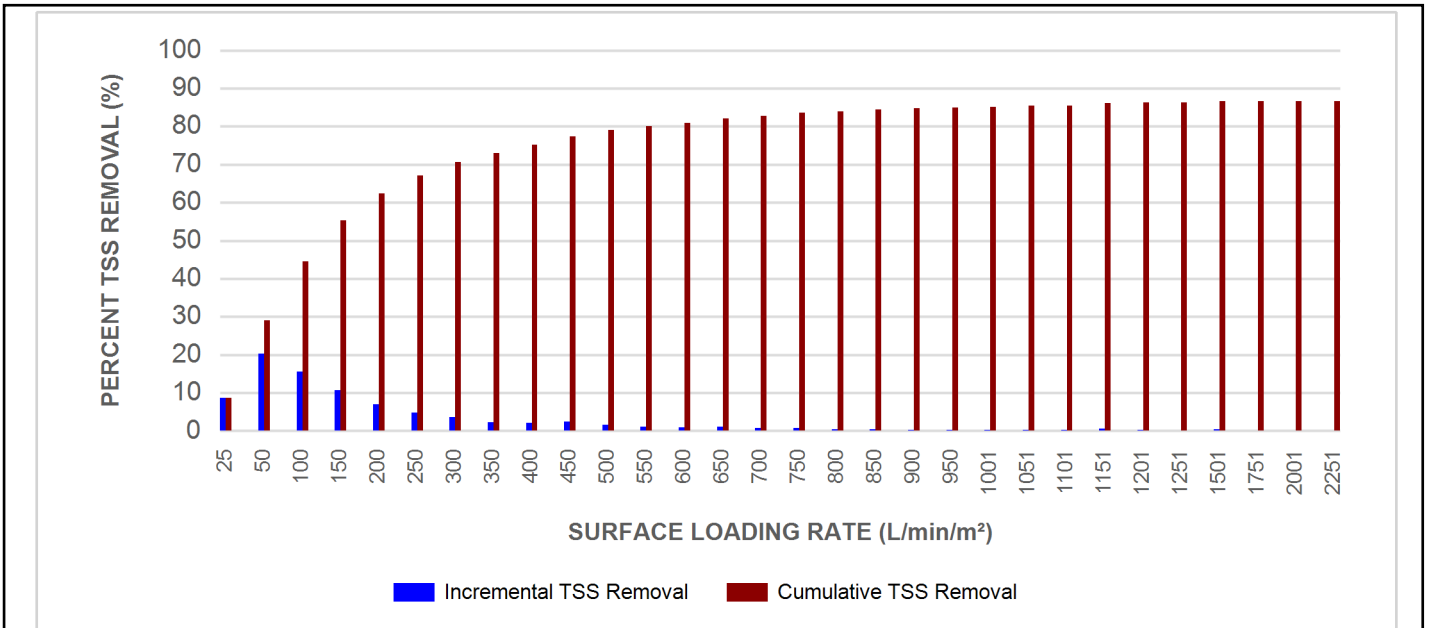

## Stormceptor® EF Sizing Report

### Maximum Pipe Diameter / Peak Conveyance

Stormceptor EF / EFO	Model Diameter		Min Angle Inlet / Outlet Pipes	Max Inlet Pipe Diameter		Max Outlet Pipe Diameter		Peak Conveyance Flow Rate	
	(m)	(ft)		(mm)	(in)	(mm)	(in)	(L/s)	(cfs)
EF4 / EFO4	1.2	4	90	609	24	609	24	425	15
EF6 / EFO6	1.8	6	90	914	36	914	36	990	35
EF8 / EFO8	2.4	8	90	1219	48	1219	48	1700	60
EF10 / EFO10	3.0	10	90	1828	72	1828	72	2830	100
EF12 / EFO12	3.6	12	90	1828	72	1828	72	2830	100

### SCOUR PREVENTION AND ONLINE CONFIGURATION

► Stormceptor® EF and EFO feature an internal bypass and superior scour prevention technology that have been demonstrated in third-party testing according to the scour testing provisions of the Canadian ETV **Procedure for Laboratory Testing of Oil-Grit Separators**, and the exceptional scour test performance has been third-party verified in accordance with the ISO 14034 ETV protocol. As a result, Stormceptor EF and EFO are approved for online installation, eliminating the need for costly additional bypass structures, piping, and installation expense.

### DESIGN FLEXIBILITY

► Stormceptor® EF and EFO offers design flexibility in one simplified platform, accepting stormwater flow from a single inlet pipe or multiple inlet pipes, and/or surface runoff through an inlet grate. The device can also serve as a junction structure, accommodate a 90-degree inlet-to-outlet bend angle, and can be modified to ensure performance in submerged conditions.

### OIL CAPTURE AND RETENTION

► While Stormceptor® EF will capture and retain oil from dry weather spills and low intensity runoff, Stormceptor® EFO has demonstrated superior oil capture and greater than 99% oil retention in third-party testing according to the light liquid re-entrainment testing provisions of the Canadian ETV **Procedure for Laboratory Testing of Oil-Grit Separators**. Stormceptor EFO is recommended for sites where oil capture and retention is a requirement.

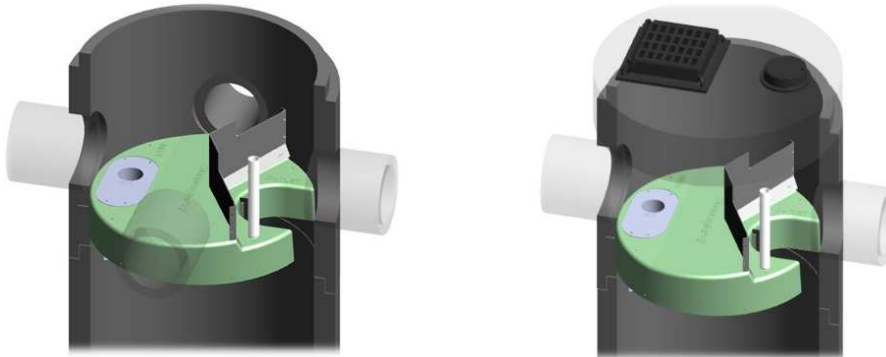

## Stormceptor® EF Sizing Report

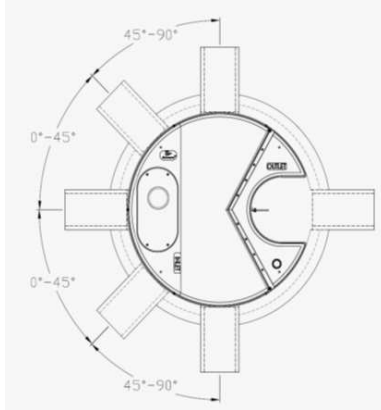

### INLET-TO-OUTLET DROP

Elevation differential between inlet and outlet pipe inverts is dictated by the angle at which the inlet pipe(s) enters the unit.

0° - 45° : The inlet pipe is 1-inch (25mm) higher than the outlet pipe.

45° - 90° : The inlet pipe is 2-inches (50mm) higher than the outlet pipe.

### HEAD LOSS

The head loss through Stormceptor EF is similar to that of a 60-degree bend structure. The applicable K value for calculating minor losses through the unit is 1.1. For submerged conditions the applicable K value is 3.0.

### Pollutant Capacity

Stormceptor EF / EFO	Model Diameter		Depth (Outlet Pipe Invert to Sump Floor)		Oil Volume		Recommended Sediment Maintenance Depth *		Maximum Sediment Volume *		Maximum Sediment Mass **	
	(m)	(ft)	(m)	(ft)	(L)	(Gal)	(mm)	(in)	(L)	(ft³)	(kg)	(lb)
EF4 / EFO4	1.2	4	1.52	5.0	265	70	203	8	1190	42	1904	5250
EF6 / EFO6	1.8	6	1.93	6.3	610	160	305	12	3470	123	5552	15375
EF8 / EFO8	2.4	8	2.59	8.5	1070	280	610	24	8780	310	14048	38750
EF10 / EFO10	3.0	10	3.25	10.7	1670	440	610	24	17790	628	28464	78500
EF12 / EFO12	3.6	12	3.89	12.8	2475	655	610	24	31220	1103	49952	137875

\*Increased sump depth may be added to increase sediment storage capacity

\*\* Average density of wet packed sediment in sump = 1.6 kg/L (100 lb/ft³ )

Feature	Benefit	Feature Appeals To
Patent-pending enhanced flow treatment and scour prevention technology	Superior, verified third-party performance	Regulator, Specifying & Design Engineer
Third-party verified light liquid capture and retention for EFO version	Proven performance for fuel/oil hotspot locations	Regulator, Specifying & Design Engineer, Site Owner
Functions as bend, junction or inlet structure	Design flexibility	Specifying & Design Engineer
Minimal drop between inlet and outlet	Site installation ease	Contractor
Large diameter outlet riser for inspection and maintenance	Easy maintenance access from grade	Maintenance Contractor & Site Owner

### STANDARD STORMCEPTOR EF/EFO DRAWINGS

For standard details, please visit <http://www.imbriumsystems.com/stormwater-treatment-solutions/stormceptor-ef>

### STANDARD STORMCEPTOR EF/EFO SPECIFICATION

For specifications, please visit <http://www.imbriumsystems.com/stormwater-treatment-solutions/stormceptor-ef>



## STANDARD PERFORMANCE SPECIFICATION FOR “OIL GRIT SEPARATOR” (OGS) STORMWATER QUALITY TREATMENT DEVICE

### PART 1 – GENERAL

#### 1.1 WORK INCLUDED

This section specifies requirements for selecting, sizing, and designing an underground Oil Grit Separator (OGS) device for stormwater quality treatment, with third-party testing results and a Statement of Verification in accordance with ISO 14034 Environmental Management – Environmental Technology Verification (ETV).

#### 1.2 REFERENCE STANDARDS & PROCEDURES

ISO 14034:2016 Environmental management – Environmental technology verification (ETV)

Canadian Environmental Technology Verification (ETV) Program’s **Procedure for Laboratory Testing of Oil-Grit Separators**

#### 1.3 SUBMITTALS

1.3.1 All submittals, including sizing reports & shop drawings, shall be submitted upon request with each order to the contractor then forwarded to the Engineer of Record for review and acceptance. Shop drawings shall detail all OGS components, elevations, and sequence of construction.

1.3.2 Alternative devices shall have features identical to or greater than the specified device, including: treatment chamber diameter, treatment chamber wet volume, sediment storage volume, and oil storage volume.

1.3.3 Unless directed otherwise by the Engineer of Record, OGS stormwater quality treatment product substitutions or alternatives submitted within ten days prior to project bid shall not be accepted. All alternatives or substitutions submitted shall be signed and sealed by a local registered Professional Engineer, based on the exact same criteria detailed in Section 3, in entirety, subject to review and approval by the Engineer of Record.

### PART 2 – PRODUCTS

#### 2.1 OGS POLLUTANT STORAGE

The OGS device shall include a sump for sediment storage, and a protected volume for the capture and storage of petroleum hydrocarbons and buoyant gross pollutants. The minimum sediment & petroleum hydrocarbon storage capacity shall be as follows:

2.1.1	4 ft (1219 mm) Diameter OGS Units:	1.19 m <sup>3</sup> sediment / 265 L oil
	6 ft (1829 mm) Diameter OGS Units:	3.48 m <sup>3</sup> sediment / 609 L oil
	8 ft (2438 mm) Diameter OGS Units:	8.78 m <sup>3</sup> sediment / 1,071 L oil
	10 ft (3048 mm) Diameter OGS Units:	17.78 m <sup>3</sup> sediment / 1,673 L oil
	12 ft (3657 mm) Diameter OGS Units:	31.23 m <sup>3</sup> sediment / 2,476 L oil

### PART 3 – PERFORMANCE & DESIGN

#### 3.1 GENERAL

The OGS stormwater quality treatment device shall be verified in accordance with ISO 14034:2016 Environmental management – Environmental technology verification (ETV). The OGS stormwater quality treatment device shall

## Stormceptor® EF Sizing Report

remove oil, sediment and gross pollutants from stormwater runoff during frequent wet weather events, and retain these pollutants during less frequent high flow wet weather events below the insert within the OGS for later removal during maintenance. The Manufacturer shall have at least ten (10) years of local experience, history and success in engineering design, manufacturing and production and supply of OGS stormwater quality treatment device systems, acceptable to the Engineer of Record.

### 3.2 SIZING METHODOLOGY

The OGS device shall be engineered, designed and sized to provide stormwater quality treatment based on treating a minimum of 90 percent of the average annual runoff volume and a minimum removal of an annual average 60% of the sediment (TSS) load based on the Particle Size Distribution (PSD) specified in the sizing report for the specified device. Sizing of the OGS shall be determined by use of a minimum ten (10) years of local historical rainfall data provided by Environment Canada. Sizing shall also be determined by use of the sediment removal performance data derived from the ISO 14034 ETV third-party verified laboratory testing data from testing conducted in accordance with the Canadian ETV protocol Procedure for Laboratory Testing of Oil-Grit Separators, as follows:

3.2.1 Sediment removal efficiency for a given surface loading rate and its associated flow rate shall be based on sediment removal efficiency demonstrated at the seven (7) tested surface loading rates specified in the protocol, ranging 40 L/min/m<sup>2</sup> to 1400 L/min/m<sup>2</sup>, and as stated in the ISO 14034 ETV Verification Statement for the OGS device.

3.2.2 Sediment removal efficiency for surface loading rates between 40 L/min/m<sup>2</sup> and 1400 L/min/m<sup>2</sup> shall be based on linear interpolation of data between consecutive tested surface loading rates.

3.2.3 Sediment removal efficiency for surface loading rates less than the lowest tested surface loading rate of 40 L/min/m<sup>2</sup> shall be assumed to be identical to the sediment removal efficiency at 40 L/min/m<sup>2</sup>. No extrapolation shall be allowed that results in a sediment removal efficiency that is greater than that demonstrated at 40 L/min/m<sup>2</sup>.

3.2.4 Sediment removal efficiency for surface loading rates greater than the highest tested surface loading rate of 1400 L/min/m<sup>2</sup> shall assume zero sediment removal for the portion of flow that exceeds 1400 L/min/m<sup>2</sup>, and shall be calculated using a simple proportioning formula, with 1400 L/min/m<sup>2</sup> in the numerator and the higher surface loading rate in the denominator, and multiplying the resulting fraction times the sediment removal efficiency at 1400 L/min/m<sup>2</sup>.

The OGS device shall also have sufficient annual sediment storage capacity as specified and calculated in Section 2.1.

### 3.3 CANADIAN ETV or ISO 14034 ETV VERIFICATION OF SCOUR TESTING

The OGS device shall have Canadian ETV or ISO 14034 ETV Verification of third-party scour testing conducted in accordance with the Canadian ETV Program's **Procedure for Laboratory Testing of Oil-Grit Separators**.

3.3.1 To be acceptable for on-line installation, the OGS device must demonstrate an average scour test effluent concentration less than 10 mg/L at each surface loading rate tested, up to and including 2600 L/min/m<sup>2</sup>.

### 3.4 LIGHT LIQUID RE-ENTRAINMENT SIMULATION TESTING

The OGS device shall have Canadian ETV or ISO 14034 ETV Verification of completed third-party Light Liquid Re-entrainment Simulation Testing in accordance with the Canadian ETV **Program's Procedure for Laboratory Testing of Oil-Grit Separators**, with results reported within the Canadian ETV or ISO 14034 ETV verification. This re-entrainment testing is conducted with the device pre-loaded with low density polyethylene (LDPE) plastic beads as a surrogate for light liquids such as oil and fuel. Testing is conducted on the same OGS unit tested for sediment removal to

## Stormceptor® EF Sizing Report

assess whether light liquids captured after a spill are effectively retained at high flow rates.

3.4.1 For an OGS device to be an acceptable stormwater treatment device on a site where vehicular traffic occurs and the potential for an oil or fuel spill exists, the OGS device must have reported verified performance results of greater than 99% cumulative retention of LDPE plastic beads for the five specified surface loading rates (ranging 200 L/min/m<sup>2</sup> to 2600 L/min/m<sup>2</sup>) in accordance with the Light Liquid Re-entrainment Simulation Testing within the Canadian ETV Program's **Procedure for Laboratory Testing of Oil-Grit Separators**. However, an OGS device shall not be allowed if the Light Liquid Re-entrainment Simulation Testing was performed with screening components within the OGS device that are effective at retaining the LDPE plastic beads, but would not be expected to retain light liquids such as oil and fuel.