

Engineering

Land/Site
Development

Municipal
Infrastructure

Environmental/
Water Resources

Traffic/
Transportation

Recreational

Planning

Land/Site
Development

Planning Application
Management

Municipal Planning

Urban Design

Expert Witness
(LPAT)

Wireless Industry

Landscape Architecture

Streetscapes &
Public Amenities

Open Space, Parks &
Recreation

Community &
Residential

Commercial &
Institutional

Environmental
Restoration



NOKIA OTTAWA INNOVATION CAMPUS 570 & 520 March Road

Development Servicing Study and Stormwater Management Report

**NOKIA OTTAWA INNOVATION CAMPUS
570 & 520 MARCH ROAD**

**DEVELOPMENT SERVICING STUDY AND
STORMWATER MANAGEMENT REPORT**

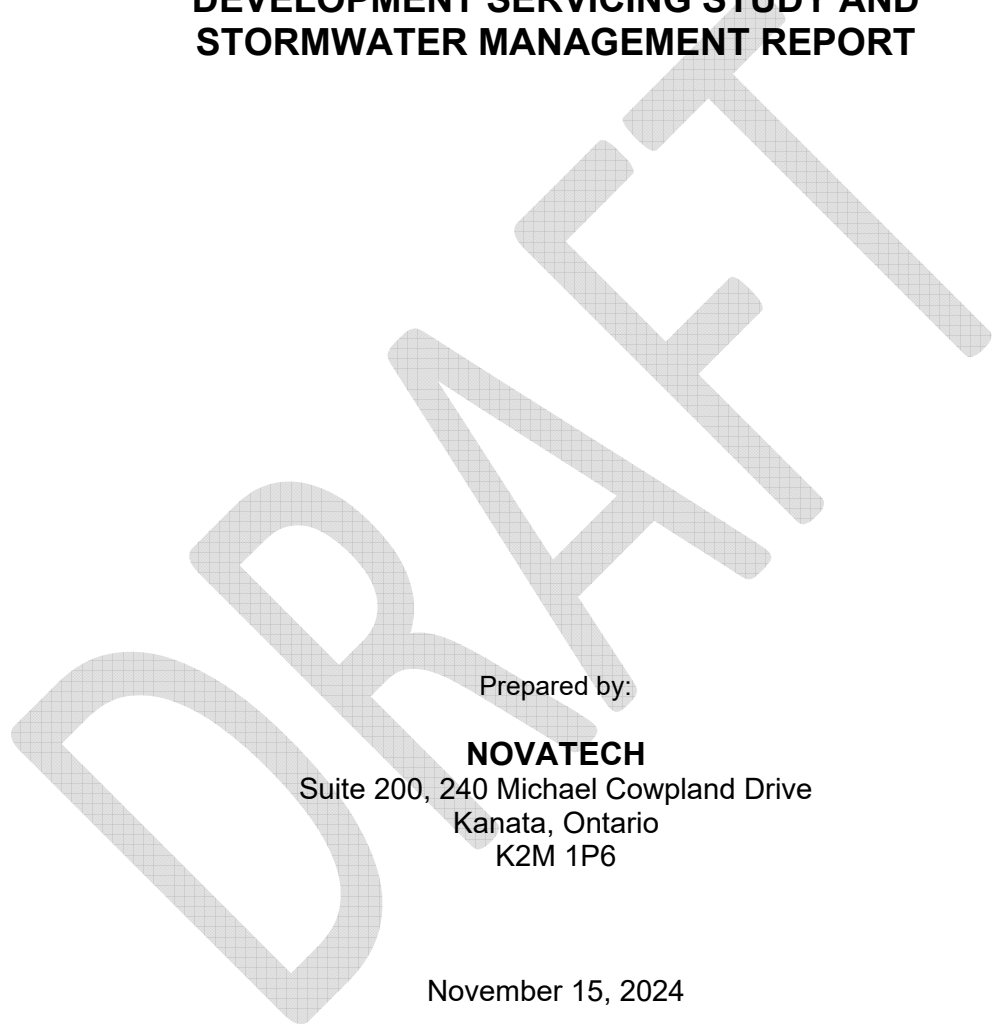

Prepared by:

NOVATECH

Suite 200, 240 Michael Cowpland Drive
Kanata, Ontario
K2M 1P6

November 15, 2024

Ref: R-2023-082
Novatech File No. 123043

November 15, 2024

Nokia Ottawa Innovation Campus
600 March Road
Ottawa, ON
K2K 2T6

Attention: Margaret Wolodarski, Program Manager

**Re: Development Servicing Study and Stormwater Management Report
Nokia Ottawa Innovation Campus
570 & 520 March Road, Ottawa, ON
Novatech File No.: 123043**

Enclosed is a copy of the 'Development Servicing Study and Stormwater Management Report' prepared for the proposed Nokia Ottawa Innovation Campus development located at 570 March Road and what is being referred to as the Retained Lands located at 520 March Road. This report addresses the approach to site servicing, grading, and stormwater management, and is being submitted in support of a Site Plan Control application.

Please contact the undersigned, should you have any questions or require additional information.

NOVATECH



François Thauvette, P. Eng.
Senior Project Manager

cc: Jean-Miguel Roy (City of Ottawa)
Elaine Guenette (S+A)
Barry Hand (Gensler)

TABLE OF CONTENTS

1.0	INTRODUCTION	1
1.1	Location and Site Description	1
1.2	Pre-Consultation Information	1
1.3	Proposed Development	2
1.4	Reference Material	2
2.0	SITE SERVICING	3
2.1	Sanitary Sewage	3
2.1.1	Post-Development Sanitary Flows	4
2.2	Water for Domestic Use and Fire Protection	6
2.2.1	Water Demands and Watermain Analysis	6
2.3	Storm Drainage and Stormwater Management	10
2.3.1	Pre-Development Conditions and Allowable Release Rate	10
2.3.2	Stormwater Management Criteria and Objectives	11
2.3.3	Post-Development Conditions	12
2.3.4	Post-Development Flows to North Outlet Sewer	13
2.3.4.1	Area A-0: Uncontrolled Runoff	13
2.3.4.2	Area A-1 – Controlled Flow from Lifestyle Street – Upper End	13
2.3.4.3	Area A-2 – Controlled Flow from Lifestyle Street – Lower End	13
2.3.4.4	Area A-3 – Controlled Flow from Retail West Roof	14
2.3.4.5	Area A-4 – Controlled Flow from Retail East Roof	15
2.3.4.6	Area A-5 – Controlled Flow from Office Tower Roof	15
2.3.4.7	Area A-6 – Controlled Flow from Social Café and Amenity Roof	17
2.3.4.8	Summary of Post- Development Flows to North Storm Outlet	17
2.3.5	Post-Development Flows to South Outlet Sewer	18
2.3.5.1	Area B-0 – Uncontrolled Direct Runoff	18
2.3.5.2	Area B-1 – Controlled Flow from R&D Lab Building	18
2.3.5.3	Area B-2 – Controlled Flow from Plaza and Entrance Dropoff	19
2.3.5.4	Area B-3 – Controlled Flow from Parking Structure and Driveway	19
2.3.5.5	Area B-4 – Controlled Flow from South Access Route	20
2.3.5.6	Area C-0 – Uncontrolled Direct Runoff from Access Route	21
2.3.5.7	Area C-1 – Controlled Flow from the Retained Lands	21
2.3.5.8	Area C-2 – Controlled Flow from the Retained Lands ROW	21
2.3.5.9	Summary of Post- Development Flows to South Stormwater Outlet	22

2.3.6	Stormwater Quality Control.....	22
3.0	SITE GRADING	23
4.0	GEOTECHNICAL INVESTIGATIONS	23
5.0	EROSION AND SEDIMENT CONTROL	23
6.0	CONCLUSION	24

LIST OF FIGURES

Figure 1: Aerial view of the subject site

Figure 2: Sanitary Sewer Drainage Plan

LIST OF APPENDICES

Appendix A: Project Correspondence

Appendix B: Development Servicing Study Checklist

Appendix C: Sanitary Sewage Calculations, Sanitary Sewer Design Sheet

Appendix D: Water Demands, FUS Calculations, **Watermain Boundary Conditions, Schematic of the Hydraulic Model and Modelling Results**

Appendix E: IDF Curves, SWM Calculations, Storm Sewer Design Sheets

Appendix F: Inlet Control Device (ICD) Information

Appendix G: Control Flow Roof Drain Information

Appendix H: Underground Stormwater Storage Chamber Information

Appendix I: KRP Stormwater Drainage Brief Excerpts

Appendix J: Engineering Drawings

LIST OF PLANS

C-100 - General Plan of Services

C-200 - Grading and Erosion & Sediment Control Plan

C-300 - Pre-Development Stormwater Management Plan

C-301 - Post-Development Stormwater Management Plan

C-400 - Sanitary Drainage Area Plan

C-500 - Storm Drainage Area Plan - North Outlet

C-501 - Storm Drainage Area Plan - South Outlet

C-600 - Plan and Profile – Legget Drive (P1) – **Not yet included (pending WM design)**

C-601 - Plan and Profile – Legget Drive (P2)

PREVIOUSLY APPROVED PLANS

98066-STM - Storm Drainage Area Plan

98066-SAN - Sanitary Drainage Area Plan

1.0 INTRODUCTION

Nokia has recently severed their 10.45 ha property into three parcels; the 600 March Road property to the north including the existing office tower and adjacent parking lots (5.18 ha), and the existing surface parking lots to the south, which will be re-developed as the new Nokia Ottawa Innovation Campus (4.49 ha) at 570 March Road as well as what is being referred to as the Retained Lands (0.78ha) at 520 March Road, which will be developed as a future phase. As part of the proposed re-development, Nokia has retained Novatech to complete the site servicing, grading, and stormwater management design for the new Nokia campus. This report is being submitted in support of a Site Plan Control application for the recently severed portion of the previously larger property.

1.1 Location and Site Description

The subject site consists of the recently severed portions of the Nokia property located at 570 & 520 March Road within the Kanata Research Park (KRP). The area to be redeveloped currently consists of the main surface parking lots for Nokia employees. The severed portions of the original property cover an approximate area of 5.270 ha (post road widening), including the new Nokia Ottawa Innovation Campus (4.49 ha) and Retained Lands (0.78ha) described above. The subject site is generally surrounded by other commercial properties. The legal description of the Nokia site is designated as Part 5 and Part 7, while the Retained Lands consists of Part 8 on Registered Plan 4R-35453.

Figure 1: Aerial view of the subject site

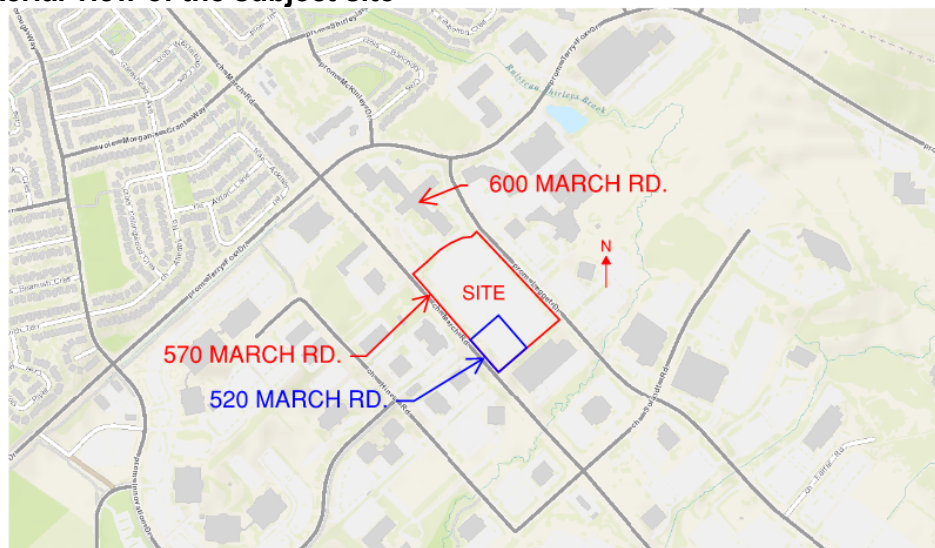

1.2 Pre-Consultation Information

An initial pre-consultation meeting was held with the City of Ottawa on February 8, 2023, at which time the client was advised of the general submission requirements. Subsequent meetings were held with City of Ottawa staff to further discuss the project and the approach to site servicing, drainage, and stormwater management. Based on a review of **O. Reg. 525/98: Approval Exemptions**, a Ministry of the Environment, Conservation and Parks (MECP) Environmental Compliance Approval (ECA) for on-site stormwater management will be required for the proposed development as multiple properties are being serviced by shared sewer systems. An ECA will also be required for the extension of the sanitary sewer in Legget Drive. Refer to **Appendix A** for a summary of the correspondence related to the proposed development.

1.3 Proposed Development

The proposed development will consist of the new Nokia Ottawa Innovation Campus, as outlined in RED, as well as the Retained Lands, outlined in BLUE, on **Figure 1**. The new Nokia campus will consist of several buildings, including an 8-storey office tower and adjacent 1-storey commercial buildings at the north end of the property, while a 5-storey R&D Lab is being proposed along Legget Drive. A central 2-storey Common Area (Social Café) will link these buildings with the 3-storey open-air parking structure, while also providing access to the central courtyard (outdoor amenity area). The Retained Lands are located in the southwest corner of the site and consist of a separate property parcel (520 March Road) to be developed in the future. The remainder of the property will consist of access roads and a large exterior work yard, which will house electrical equipment, battery banks and generators. The proposed development will include two private roadways between March Road and Legget Drive: the Lifestyle Street along the north end of the property to provide access to the office tower and commercial spaces, as well as a service road at the south end of the property to provide access to the Retained Lands and the 'back' of the Nokia Campus. Visitor parking will be provided off March Road, on the west side of the office tower, adjacent to the central courtyard. Shipping and receiving will be provided off Legget Drive, both at-grade near the southwest corner of the Lab building and/or via the underground truck dock at the north end of the Lab building.

The proposed Nokia Campus and Retained Lands will be serviced by the municipal sanitary and storm sewers in Legget Drive, including the construction of new private on-site sewers, as well as an extension of the municipal sanitary sewer within Legget Drive. A new private looped watermain network running along the Lifestyle Street, the west property line and the south service road will be required to provide necessary water to the proposed development.

1.4 Reference Material

The following design guidelines have been used to establish the servicing and stormwater management requirements for the proposed development:

- Ottawa Sewer Design Guidelines (2012) and Technical Bulletins (2010-present)
- Ottawa Design Guidelines for Water Distribution (2010) & Tech. Bulletins (2010-present)
- Ministry of the Environment Design Guidelines for Sewage Works (2008)
- Ministry of the Environment Stormwater Management Planning and Design Manual (2003)
- Ministry of the Environment Design Guidelines for Drinking Water Systems (2008)
- Fire Underwriters Survey (FUS) Water Supply for Public Fire protection

The following reports and studies were reviewed and/or prepared as part of the design process:

1. The "Shirley's Brook and Watts Creek Subwatershed Study" prepared by Dillon Consulting in September 1999.
2. The "Stormwater Management Plan, Kanata Research Park" prepared by Novatech Engineering Consultants Ltd., revised in April 2000.
3. The "Sanitary and Storm Trunk Sewer Design Brief - Kanata Research Park Lands" prepared by Novatech, dated November 12, 2014.
4. The "Assessment of Adequacy of Public Services Report," prepared by CIMA+, dated July 28, 2022.
5. The Geotechnical Investigation and Hydrogeological Assessment Report (No.: PG12606873-RPT-1), prepared by GHD on March 6, 2024.

6. The Reliance Letter for Geotechnical Investigation and Hydrogeological Assessment (Ref No.: 12646241), prepared by GHD on September 5, 2024.
7. The “Sanitary and Storm Trunk Sewer Design Brief – Nokia Ottawa Innovation Campus” prepared by Novatech, dated November 15, 2024.

2.0 SITE SERVICING

The objective of the site servicing design is to provide proper sewage outlets, a suitable domestic water supply, and to ensure that appropriate fire protection is provided for the proposed development. The servicing criteria, the expected sewage flows, and the water demands are to conform to the requirements of the City of Ottawa municipal design guidelines for sewer and water distribution systems. Refer to the enclosed **General Plan of Services** (C-100) and to the subsequent sections of the report for further details.

The City of Ottawa Servicing Study Guidelines for Development Applications requires that a Development Servicing Study Checklist be included in the report to confirm that each applicable item is deemed complete and ready for review by City of Ottawa Infrastructure Approvals. A completed checklist is enclosed in **Appendix B** of the report.

2.1 Sanitary Sewage

The proposed development will be serviced by extending a new 250mm dia. municipal sanitary sewer north along Legget Drive, as well as by extending private on-site sanitary sewers and building services. A private sewer is being proposed along the Lifestyle Street at the north end of the property to service the office tower and commercial/retail buildings (shown in BLUE); while another private sanitary sewer is required at the south end to service the parking garage and Retained Lands parcel (shown in ORANGE). The R&D Lab building (shown in YELLOW) will be serviced directly from the municipal sanitary sewer in Legget Drive. As the proposed use of the buildings will consist of office space, commercial retail, and lab uses (electrical/microelectronic works), no campus building will release industrial effluents. All proposed sanitary service laterals will be equipped with a backflow preventer. Refer to **Figure 2** for details of the on-site sanitary sewer drainage plan.

All sanitary site flows will be directed to the 250mm dia. sanitary sewer routed through the KRP lands. This sewer currently outlets into the 750mm dia. March Trunk Sewer on the Marshes Golf Course. As indicated on the previously approved Sanitary Drainage Area Plan (98066-SAN) and described in the ‘Sanitary and Storm Trunk Sewer Design Brief – Kanata Research Park Lands’³, prepared as part of the Sanmina development (located at 500 March Road), sanitary flows from the subject site were always intended to be directed into this municipal sanitary sewer system. An easement is already in place for the sanitary sewers located on the KRP lands.

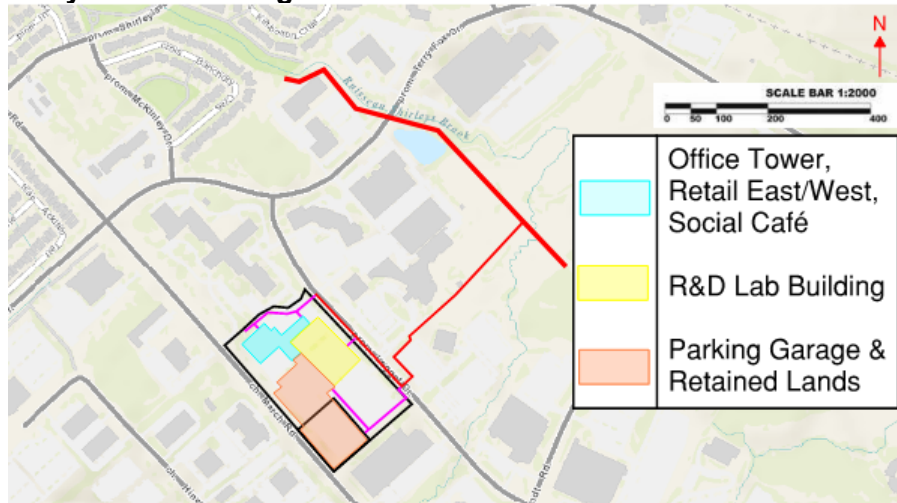
Figure 2: Sanitary Sewer Drainage Plan

The 'Sanitary and Storm Trunk Sewer Design Brief – Nokia Ottawa Innovation Campus'⁷ has been prepared as part of the proposed development to include anticipated sewage flows from the new Nokia campus and Retained Lands. An amendment to the existing Joint Use and Maintenance Agreement (JUMA) will also be required to account for these newly anticipated sanitary sewage flows. The Updated Sanitary and Storm Trunk Sewer Design Brief⁷ also identifies the excess capacity available within the sanitary sewer system should it be required for the 'future' mixed-use lands to the north (600 March Road), once the existing Nokia Office building is demolished.

2.1.1 Post-Development Sanitary Flows

The City of Ottawa design criteria were used to calculate the theoretical sanitary flows for the proposed development. The following design criteria were taken from the City of Ottawa Sewer Design Guidelines and/or from subsequent Technical Bulletins:

Nokia Campus and Retained Lands - Commercial and/or Residential Uses

- Design Population (Employees): 700 office, 600 lab, and Gym/Café/Restaurant users
- Average Daily Sanitary Flows: 75 L/person/day (Office and Lab staff)
- Average Daily Sanitary Flows: 40 L/user/day (Gym + Showers)
- Average Daily Sanitary Flows: 125 L/seat/day (Café/Restaurant, Quick Service)
- Commercial Peaking Factor = 1.5
- Infiltration Allowance: 0.33 L/s/ha (ISTB-2018-01)

Table 1 identifies the theoretical sanitary flows for the proposed development based on the above design criteria and breaks it down per sanitary connection point to the municipal sanitary sewer system in Legget Drive.

Table 1: Theoretical Post-Development Sanitary Flows

Building ID	Use	Staff / Seats / Area	Average Flow (L/s)	Peaking Factor**	Peak Flow (L/s) ***
Sewage Flows to Legget Sanitary Sewer via Sewer in Lifestyle Street					
Office Tower	Office	700 staff	0.61	1.5	0.91
Retail East	Gym + Showers	200 users*	0.19		0.28
Retail West	Café/Restaurant	50 seats*	0.22		0.33
Social Café	Quick Service	50 seats*	0.22		0.33
Infiltration (ha)	-	0.743 ha.	-	-	0.25
Sub-Total	-	-	1.24	-	2.10
Sewage Flows Directly to Legget Sanitary Sewer					
Lab	Lab	600 staff	0.52	1.5	0.78
Infiltration (ha)	-	0.735 ha.	-	-	0.24
Sub-Total	-	-	0.52	-	1.02
Sewage Flows to Legget Sanitary Sewer via Sewer in South Access Road					
Parking Garage	Parking	-	-	-	-
Infiltration (ha)	-	0.953 ha.	-	-	0.31
Sub-Total Parking Garage	-	-	-	-	0.31
Retained Lands	Potential Future Office	500 staff	0.43	1.5	0.65
Infiltration (ha)	-	0.777 ha.	-	-	0.26
Sub-Total Retained Lands	-	-	0.43	-	0.91
Sub-Total	-	-	0.43	-	1.22
Total	-	-	2.19	-	4.34

*Total of 200 Gym users assumed 2 x per day and 50 Café/Quick Service seats assumed to be used 3 x per day.

**A peaking factor of 1.5 is appropriate for the intended use and is consistent with the previous design of the KRP sanitary trunk sewer system.

***Represents rounded values.

New 250mm dia. sanitary sewers are being proposed both along Legget Drive and along Lifestyle Street to match the size of the municipal sanitary sewer in Legget Drive and to maximize the conveyance capacity of the system. The sanitary sewer system (both private and public) will have more than sufficient capacity to service the proposed development, as demonstrated in the attached sanitary sewer design sheet, and will potentially provide excess capacity for future mixed-use lands to the north (once the existing Nokia Office building is demolished). The potential excess capacity for future mixed-use lands to the north cannot exceed the overall capacity of the downstream sewer system on KRP Lands. At the client's request, a new 250mm dia. sanitary sewer is also being proposed along the south service road to provide flexibility for the future development of the Retained Lands parcel. This sewer will have sufficient capacity to service the proposed parking garage and future development on the Retained Lands.

This sanitary servicing approach is generally consistent with the approach outlined in the 'Assessment of Adequacy of Public Services Report'⁴. Refer to **Appendix C** for detailed sanitary

sewage calculations and the sanitary sewer design sheet. Also refer to the 'Sanitary and Storm Trunk Sewer Design Brief – Nokia Ottawa Innovation Campus'⁷ for further details.

2.2 Water for Domestic Use and Fire Protection

The subject site is located within the City of Ottawa 2W watermain pressure zone. The proposed development will be serviced by extending a new private watermain onto the site. Due to the size of the development, a looped watermain network will be required to provide adequate water for domestic use and firefighting purposes. Based on the layout of the Nokia buildings and Retained Lands parcel, a new watermain network will be extended from Legget Drive west along Lifestyle Street, south along the west property line, through the Retained Lands and out to Legget Drive along the south service road (all within an easement). Typically, the City of Ottawa will not allow new connections to 610mm dia. feeder mains, however in this instance there are no other nearby local watermains fronting the property. As a result, two (2) new connections are being proposed to the 610mm dia. feeder main within Legget Drive. The proposed watermain configuration will ensure the proposed development has a looped system with feeds on either side of the isolation valve in Legget Drive. Shut-off valves will be provided at the property line, as well as along the private watermain and building service connections. The water meters will be located inside the respective buildings with remote water meters installed on the exterior face of the buildings. The proposed Nokia buildings, excluding the open-air parking garage, and (future) Retained Lands building will be fully sprinklered with their respective fire department (siamese) connections located within 45m of a nearby fire hydrant.

This water servicing approach is generally consistent with the approach outlined in the 'Assessment of Adequacy of Public Services Report'⁴.

2.2.1 Water Demands and Watermain Analysis

The theoretical water demands for the proposed development are based on the design criteria from the City of Ottawa Water Distribution Guidelines and/or from subsequent Technical Bulletins. The Fire Underwriters Survey (FUS) method was used to calculate the fire flow requirements based on building information (i.e., building materials, occupancy hazards, etc.) provided by the architect. The water demands are calculated based on the following criteria:

Nokia Campus and Retained Lands - Commercial and/or Residential Use

- Design Population (Employees): 700 office, 600 lab, and Gym/Café/Restaurant users
- Average Daily Water Demands: 75 L/person/day (Office and Lab staff)
- Average Daily Water Demands: 40 L/user/day (Gym + Showers)
- Average Daily Water Demands: 125 L/seat/day (Café/Restaurant, Quick Service)
- Maximum Day Demand Peaking Factor = 1.5 x Avg. Day Demand (City Water Table 4.2)
- Peak Hour Demand Peaking Factor = 1.8 x Max. Day Demand (City Water Table 4.2)

Table 2 identifies the theoretical domestic water demands and fire flow requirements for the development based on the above design criteria.

Table 2: Theoretical Water Demand and FUS Fire Flows for Proposed Development

Building ID	Use	Staff / Seats / Area	Avg. Day Demand (L/s)	Max. Day Demand (L/s)	Peak Hour Demand (L/s)**	FUS Fire Flow (L/s) ***
Water Supplied by (Looped) Watermain in Lifestyle Street						
Office Tower	Office	700 staff	0.61	0.91	1.64	117
Retail East	Gym + Showers	200 users*	0.19	0.28	0.50	50
Retail West	Café/Restaurant	50 seats*	0.22	0.33	0.59	100
Social Café & Amenity	Quick Service Retail	50 seats*	0.22	0.33	0.59	117
Sub-Total	-	-	1.24	1.85	3.32	-
Water Supplied by (Looped) Watermain in Lifestyle Street						
Lab	Lab	600 staff	0.52	0.78	1.41	233
Sub-Total	-	600 staff	0.52	0.78	1.41	233
Water Supplied by (Looped) Watermain in South Service Road						
Parking Garage	Parking	-	-	-	-	333
Retained Lands	Office (assumed)	500	0.43	0.65	1.17	200
Sub-Total	-	-	0.43	0.43	1.17	-
Total	-	-	2.18	3.27	5.89	-

*Total of 200 Gym users assumed 2 x per day and 50 Café/Quick Service seats assumed to be used 3 x per day.

A peaking factor of **1.5 x Max Day is appropriate for the intended use and is consistent with the previous design of the KRP sanitary trunk sewer system.

***FUS Fire Flow for Social Café is combined with the Office Tower FUS Fire Flow.

Preliminary domestic water demands, and fire flow requirements were provided to the City of Ottawa to obtain municipal watermain boundary conditions. **Table 2.1** summarizes preliminary hydraulic analysis results based on municipal watermain boundary conditions provided by the City of Ottawa. ****CITY OF OTTAWA DID NOT PROVIDE WATERMAIN BOUNDARY CONDITIONS DUE TO THEIR CONCERN WITH THE PROPOSED LOOPED WATERMAIN CONFIGURATION INCLUDING 2 NEW CONNECTIONS TO THE 610mm DIA. FEEDERMAIN IN LEGGET DRIVE****

Table 2.1: Hydraulic Boundary Conditions Provided by the City

Municipal Watermain Boundary Condition	Boundary Condition	Normal Operating Pressure Range (psi)	Anticipated WM Pressure (psi)*
Connection #1 - 610mm dia. WM in Legget Drive Right-of-Way (at North end of subject site)			
Minimum HGL (Peak Hour Demand)	___ m	40 psi (min.)	~ ___ psi
Maximum HGL (Max Day Demand)	___ m	50 - 70 psi	~ ___ psi
HGL (Max Day + 117 L/s Fire Flow)	___ m	20 psi (min.)	~ ___ psi

HGL (Max Day + 200 L/s Fire Flow)	___ m	20 psi (min.)	~ ___ psi
HGL (Max Day + 233 L/s Fire Flow)	___ m	20 psi (min.)	~ ___ psi
HGL (Max Day + 333 L/s Fire Flow)	___ m	20 psi (min.)	~ ___ psi
Connection #2 - 610mm dia. WM in Legget Drive Right-of-Way (at South end of subject site)			
Minimum HGL (Peak Hour Demand)	___ m	40 psi (min.)	~ ___ psi
Maximum HGL (Max Day Demand)	___ m	50 - 70 psi	~ ___ psi
HGL (Max Day + 117 L/s Fire Flow)	___ m	20 psi (min.)	~ ___ psi
HGL (Max Day + 200 L/s Fire Flow)	___ m	20 psi (min.)	~ ___ psi
HGL (Max Day + 233 L/s Fire Flow)	___ m	20 psi (min.)	~ ___ psi
HGL (Max Day + 333 L/s Fire Flow)	___ m	20 psi (min.)	~ ___ psi

*Based on approximate roadway elevations of 79.5m and 79.4m in Legget Drive at service connection locations 1 (north end) and 2 (south end). Design pressure = (HGL – watermain elevation) x 1.42197 PSI/m.

A multi-hydrant approach to firefighting will be required to supply the fire flow calculated above. There are several Class AA (blue bonnet) hydrants within 150m of the proposed development, including both municipal hydrants along Legget Drive and private hydrants fed off the proposed private looped watermain. Based on the City of Ottawa Technical Bulletin ISTB-2018-02, Class AA (blue bonnet) hydrants within 75m of the site have a maximum capacity 95 L/s while hydrants between 75m and 150m of the site have a maximum capacity 63 L/s (at a pressure of 20 PSI). The combined maximum flow from the nearby hydrants will provide the Max Day + Fire Flow requirement of the proposed development. **Table 2.2** summarizes the total theoretical combined fire flow available from the nearby fire hydrants (municipal and private) and compares it to the fire flow demands based on FUS calculations.

Table 2.2: Theoretical Fire Protection Summary Table

Building	Fire Flow Demand (L/s)	Fire Hydrant(s) within 75m (~ 95 L/s each)	Fire Hydrant(s) within 150m (~ 63 L/s each)	Theoretical Combined Available Fire Flow (L/s)
Water Supplied by Hydrants in Lifestyle St., Legget Dr., March Rd., and/or Visitor Parking				
Office Tower + Social Cafe	117	4	1	>117
Retail East	50	2	2	>50
Retail West	100	3	1	>100
Water Supplied by Hydrants in Legget Drive and/or South Service Road				
Lab	233	3	2	>233
Water Supplied by Hydrants along March Rd., Visitor Parking and/or South Service Road				
Parking Garage	333	4	3	>333
Retained Lands	200	5	1	>200

The following design criteria were taken from Section 4.2.2 – ‘Watermain Pressure and Demand Objectives’ of the City of Ottawa Design Guidelines for Water Distribution:

- Normal operating pressures are to range between 345 kPa (50 psi) and 483 kPa (70 psi) under Max Day demands.
- Minimum system pressures are to be 276 kPa (40 psi) under Peak Hour demands.
- Minimum system pressures are to be 140 kPa (20 psi) under Max Day + Fire Flow demands.

The hydraulic model EPANET was used to analyzing the performance of the proposed watermain configuration for three (3) theoretical conditions:

- Peak Hour Demand
- Maximum HGL
- Maximum Day + Fire Flow Demand

A schematic representation of the hydraulic network depicts the node and pipe numbers used in the model. The model is based on hydraulic boundary conditions provided by the City of Ottawa. ****CITY OF OTTAWA DID NOT PROVIDE WATERMAIN BOUNDARY CONDITIONS DUE TO THEIR CONCERN WITH THE PROPOSED LOOPED WATERMAIN CONFIGURATION INCLUDING 2 NEW CONNECTIONS TO THE 610mm DIA. FEEDERMAIN IN LEGGET DRIVE****

Tables 2.3, 2.4 and 2.5 summarize the hydraulic model results. **The values demonstrate that fire flow conditions for the buildings can be met. Refer to Appendix D for City of Ottawa boundary conditions, the hydraulic modeling schematic and modeling results.**

Table 2.3: Peak Hour Demand

Operating Condition	Minimum System Pressure	Maximum System Pressure
Peak Hour demands of XX L/s at Nokia Bldg & XX L/s at Future Development of Retained Lands	Minimum system pressure of __ kPa (__ psi) is available at Node __ ()	Maximum system pressure of __ kPa (__ psi) is available at Node __ ()

Table 2.4: Maximum HGL

Operating Condition	Minimum System Pressure	Maximum System Pressure
Max Day demands of XX L/s at Nokia Bldg & XX L/s at Future Development of Retained Lands	Minimum system pressure of __ kPa (__ psi) is available at Node __ ()	Maximum system pressure of __ kPa (__ psi) is available at Node __ ()

Table 2.5: Maximum Day + Fire Flow Demand

Operating Condition	Minimum System Pressure	Maximum System Pressure
Max Day Demands: XX L/s at Nokia Bldg & XX L/s at Future Development of Retained Lands Fire Flow Demand: 95 L/s at ____, 95 L/s at ____ and 95L/s at _____.	Minimum system pressure of __ kPa (__ psi) is available at Node __ (__)	Maximum system pressure of __ kPa (__ psi) is available at Node __ (__)
Max Day Demands: XX L/s at Nokia Bldg & XX L/s at Future Development of Retained Lands Fire Flow Demand: 95 L/s at ____, 95 L/s at ____ and 95L/s at _____.	Minimum system pressure of __ kPa (__ psi) is available at Node __ (__)	Maximum system pressure of __ kPa (__ psi) is available at Node __ (__)
Max Day Demands: XX L/s at Nokia Bldg & XX L/s at Future Development of Retained Lands Fire Flow Demand: 95 L/s at ____, 95 L/s at ____ and 95L/s at _____.	Minimum system pressure of __ kPa (__ psi) is available at Node __ (__)	Maximum system pressure of __ kPa (__ psi) is available at Node __ (__)
Max Day Demands: XX L/s at Nokia Bldg & XX L/s at Future Development of Retained Lands Fire Flow Demand: 95 L/s at ____, 95 L/s at ____, 95 L/s at ____ and 95L/s at _____.	Minimum system pressure of __ kPa (__ psi) is available at Node __ (__)	Maximum system pressure of __ kPa (__ psi) is available at Node __ (__)

The model indicates that the municipal and private watermain network will provide adequate water and system pressures under the specified 'Max Day + Fire Flow' and 'Peak Hour' conditions. Booster pump(s) are anticipated to be required to provide adequate water pressure to the upper floors of the office tower and Lab building. However, pressure reducing valves may be required as system pressures will exceed 80 psi during certain conditions.

Refer to **Appendix D** for detailed calculations and correspondence from the City of Ottawa.

2.3 Storm Drainage and Stormwater Management

On-site stormwater management will be required for the proposed development to meet the requirements of the City of Ottawa. The stormwater strategy for this development will be consistent with previously approved KRP SWM reports.

2.3.1 Pre-Development Conditions and Allowable Release Rate

Under current conditions, stormwater runoff from the subject site is currently being discharged into two (2) separate storm sewer systems. Both sewer systems discharge into the existing

stormwater management (SWM) Facility No. 1, located behind the Brookstreet Hotel on KRP lands. To maintain consistency with approved designs, the previous SMP KRP Reports were reviewed to determine existing stormwater management criteria including allowable release rates for the subject site. As indicated on the previously approved Storm Drainage Area Plan (98066-STM), stormwater runoff from the subject site (i.e., existing surface parking lots) flows into the two (2) distinct storm outlets as follows:

- The northern portion of the existing parking lot (Area “PRE-A”) currently flows into the northern storm sewer system located on the KRP lands directly across Legget Drive to the east. The maximum allowable release rate from this portion of the subject site into this sewer system is 63.8 L/s.
- The southern portion of the existing parking lot (Area “PRE-B1”) currently flows into the southern storm sewer system located on the KRP lands via the municipal storm sewer in Legget Drive. Most of the runoff from the undeveloped strip along the south property line (Area “PRE-B2”) currently sheet-drains uncontrolled into the Legget Drive municipal Right-of-Way or directly onto the adjacent Sanmina property (500 March Road) before flowing into the southern storm sewer system. The maximum allowable release rate from this portion of the subject site is 235.1 L/s (152 L/s + 83.1 L/s).

Refer to the enclosed Pre-Development Stormwater Management Plan (C-300) for sub-catchment areas, **Appendix I** for excerpts from the previously approved ‘Stormwater Management Plan, Kanata Research Park’², and to **Appendix J** for a copy of the previously approved Storm Drainage Area Plan (98066-STM).

2.3.2 Stormwater Management Criteria and Objectives

The stormwater management (SWM) criteria have been provided during pre-consultation meetings with the City of Ottawa. The SWM criteria and design objectives are as follows:

- Provide a dual drainage system (i.e., minor, and major system flows).
- Maintain consistency with the previously approved Kanata Research Park - Stormwater Management Plans and Reports, by providing the follows stormwater quantity and quality control measures:
 - Control post-development flows into the northern storm sewer system located on the KRP lands to a maximum allowable release rate of 63.8 L/s.
 - Control post-development flows into the southern storm sewer system located on the KRP lands to a maximum allowable release rate of 235.1 L/s.
 - Store and control post-development on-site runoff in excess of the allowable release rates specified above, prior to releasing flows into the downstream storm sewer systems. Provide on-site stormwater quantity control measures for storms up to and including the 100-year design event.
 - Provide on-site stormwater quality control equivalent to an “Enhanced” Level of Protection (i.e., minimum 80% TSS removal and 90% of annual runoff treated) via a “treatment train”, combining raingardens, bioswales, and mechanical separators, prior to releasing flows from the site. The proposed on-site treatment train measures are in addition to the water quality treatment provided by the downstream stormwater management facility located on KRP Lands to the east.
 - Water temperature target mitigation measures as described in the previously approved Shirleys Brook Subwatershed report¹.

- Ensure that no surface ponding will occur on the paved surfaces (parking lots and drive aisles) during the 2-year storm event.
- Provide guidelines to ensure that site preparation and construction is in accordance with the current Best Management Practices for Erosion and Sediment Control.

2.3.3 Post-Development Conditions

Under post-development conditions, the proposed development, including the Nokia Campus and Retained Land, will be serviced by extending new on-site storm sewer systems. Flows will be attenuated on-site prior to being directed to the existing stormwater management (SWM) Facility No. 1 on KRP lands, via the sewer systems on the north and south sides of the Brookstreet Hotel.

To mitigate the stormwater related impacts due to the increase in imperviousness of the site, stormwater runoff will be attenuated using control flow drains on certain building roofs, using inlet control devices (ICD) within the on-site storm sewer system, and the internal SWM cistern of the R&D Lab building. Flows will be controlled for storms up to and including the 100-year design event. All proposed storm service laterals will be equipped with backflow prevention devices to protect the buildings from any potential sewer back-ups. Due to the existing grades, runoff from a small portion of the site will drain uncontrolled off site.

On-site stormwater quality control will be achieved using a “treatment train”, with flows being treated by a combination of rain gardens, bioswales, and oil and grit separator (OGS) units installed at the site’s north and south stormwater outlets. Additional off-site stormwater quality treatment will be provided by the existing downstream stormwater management facility, as outlined in the previously approved ‘Stormwater Management Plan, Kanata Research Park’². This design is generally consistent with the MVCA’s quality control recommendations, as outlined in the approved ‘Assessment of Adequacy of Public Services Report’⁴.

Stormwater runoff from the visitor parking area and central courtyard will be directed to nearby bioswales, thus eliminating the potential for stormwater management on the surface of large, paved parking lots prone to increase water temperatures. Furthermore, most of the on-site stormwater management (storage) will be provided within underground SWM storage chambers within an internal SWM cistern, or on light coloured (white) building roofs, thus providing thermal mitigation measures to meet water temperature targets. This design is consistent with the MVCA’s recommendations to implement thermal mitigation measures in the overall SWM design, as outlined in the MVCA’s Shirley’s Brook 2016 Summary Report.

The two storm sewer outlets have limited conveyance capacity (maximum allowable release rate). As a result, drainage from the subject site will have to be split based on the relative size of the sub-catchment areas, the imperviousness of these areas, and potential on-site storage. In general, stormwater runoff from Lifestyle Street, Office Tower, Retail East/West building roofs will be directed to the northern storm sewer system located on KRP lands, while runoff from the remainder of the Nokia site, including the R&D Lab, parking garage, work yard, south service road, and Retained Lands will be directed to the southern storm sewer system on KRP lands. As indicated above, the stormwater management design for the proposed development will include on-site water quantity control prior to releasing flows from the site. Refer to the enclosed Post-Development Stormwater Management Plan (C-301) for sub-catchment areas and to **Appendix E** for detailed stormwater calculations and the storm sewer design sheets. Also refer to the ‘Sanitary and Storm Trunk Sewer Design Brief – Nokia Ottawa Innovation Campus’⁷ for further details.

2.3.4 Post-Development Flows to North Outlet Sewer

To maintain consistency with the previously approved ‘Stormwater Management Plan, Kanata Research Park Report’², post-development stormwater flows from sub-catchment Areas A-0 to A-6 will be controlled to a maximum release rate of 63.8 L/s, prior to being released into northern storm sewer system located on the KRP lands.

2.3.4.1 Area A-0: Uncontrolled Runoff

The uncontrolled post-development flows from sub-catchment area A-0a, which sheet drain to the adjacent Nokia property (600 March Road), were calculated using the Rational Method to be approximately 1.7 L/s during the 2-year design event, 2.3 L/s during the 5-year design event and 5.0 L/s during the 100-year design event.

The uncontrolled post-development flows from sub-catchment area A-0b, which sheet drain directly to Legget Drive, were calculated using the Rational Method to be approximately 0.3 L/s during the 2-year design event, 0.4 L/s during the 5-year design event and 1.0 L/s during the 100-year design event. Refer to the Post-Development Stormwater Management Plan (C-301) and **Appendix E** for detailed SWM calculations.

2.3.4.2 Area A-1 – Controlled Flow from Lifestyle Street – Upper End

The post-development flow from this sub-catchment area will be attenuated by an ICD installed in the outlet pipe of STMMH 102. Stormwater runoff from this sub-catchment area will be temporarily stored in underground stormwater storage chambers, within the storm sewer system, and potentially on the surface prior to being discharged into the downstream storm sewer system.

Table 3.1 summarizes the post-development design flow from this sub-catchment area as well as the ICD specifications, the anticipated ponding elevations, storage volumes required and storage volume provided for the 2-year, 5-year and 100-year design events.

Table 3.1: Stormwater Flows, ICD & Storage

Design Event	Controlled Site Flows from Area A-1					
	ICD Type	Peak Flow	Ponding Depth/Elev.	~Average Flow (50% Qpeak)	Storage Vol. Required*	Max Storage Provided
2-Year	Tempest Vortex LMF Model 100 ICD	5.9 L/s	0.00 m (80.47 m)	3.0 L/s	20.6 m ³	65.5 m ³
5-Year		6.6 L/s	0.00 m (80.65 m)	3.3 L/s	27.9 m ³	
100-Year		8.5 L/s	0.00 m (81.30 m)	4.3 L/s	63.7 m ³	

*Storage volumes are based on the 50% Qpeak flow rates, which generally represents the average flow.

Refer to **Appendix E** for detailed SWM calculations and to **Appendix F** for ICD information.

2.3.4.3 Area A-2 – Controlled Flow from Lifestyle Street – Lower End

The post-development flow from this sub-catchment area will be attenuated by an ICD installed in the outlet pipe of CBMH 251. Stormwater runoff from this sub-catchment area will be temporarily stored in underground stormwater storage chambers, within the storm sewer system, and potentially on the surface prior to being discharged into the downstream storm sewer system.

Table 3.2 summarizes the post-development design flow from this sub-catchment area as well as the ICD specifications, the anticipated ponding elevations, storage volumes required and storage volume provided for the 2-year, 5-year and 100-year design events.

Table 3.2: Stormwater Flows, ICD & Storage

Design Event	Controlled Site Flows from Area A-2					
	ICD Type	Peak Flow	Ponding Depth/Elev.	~Average Flow (50% Qpeak)	Storage Vol. Required*	Max Storage Provided
2-Year	Tempest HF Type B ICD	15.5 L/s	0.00 m (78.50 m)	7.8 L/s	37.6 m ³	123.8 m ³
5-Year		18.2 L/s	0.00 m (78.66 m)	9.1 L/s	53.7 m ³	
100-Year		26.0 L/s	0.00 m (79.28 m)	13.0 L/s	117.8 m ³	

*Storage volumes are based on the 50% Qpeak flow rates, which generally represents the average flow.

Refer to **Appendix E** for detailed SWM calculations and to **Appendix F** for ICD information.

2.3.4.4 Area A-3 – Controlled Flow from Retail West Roof

The post-development flow from this sub-catchment area will be attenuated using Watts adjustable 'Accutrol' control flow roof drains (model number RD-100-A-ADJ) prior to being directed to the downstream storm sewer via the proposed building service.

Table 3.3 summarizes the post-development design flows from this sub-catchment area as well as the type of roof drains, the maximum anticipated ponding depths, storage volumes required and storage volumes provided for the 2-year, 5-year and 100-year design events.

Table 3.3 - Controlled Flow Roof Drains

Roof Drain ID & Drainage Area (ha)	Number of Roof Drains	Watts Roof Drain Model ID (Weir Opening)	Controlled Flow per Drain (L/s)			Approximate Ponding Depth Above Drains (m)			Storage Volume Required (m ³)			Max. Storage Available (m ³)
			2 Yr	5 Yr	100 Yr	2 Yr	5 Yr	100 Yr	2 Yr	5 Yr	100 Yr	
A3-RD 1	1	RD-100-A-ADJ (Fully Exposed)	0.9 5	1.26	1.89	0.08	0.10	0.15	7.5	10.1	20.6	21.2
A3-RD 2	1	RD-100-A-ADJ (Fully Exposed)	0.9 5	1.26	1.89	0.08	0.10	0.15	7.5	10.1	20.6	20.8
Total Roof (0.098 ha)	2	-	1.9*	2.5*	3.8*	-	-	-	14.9*	20.1*	41.2*	42.0*

*Table represents rounded values

Refer to **Appendix E** for detailed SWM calculations and **Appendix G** for the control flow roof drain information.

2.3.4.5 Area A-4 – Controlled Flow from Retail East Roof

The post-development flow from this sub-catchment area will be attenuated using Watts adjustable ‘Accutrol’ control flow roof drains (model number RD-100-A-ADJ) prior to being directed to the downstream storm sewer via the proposed building service.

Table 3.4 summarizes the post-development design flows from this sub-catchment area as well as the type of roof drains, the maximum anticipated ponding depths, storage volumes required and storage volumes provided for the 2-year, 5-year and 100-year design events.

Table 3.4: Controlled Flow Roof Drains

Roof Drain ID & Drainage Area (ha)	No. of Roof Drains	Watts Roof Drain Model ID (Weir Opening)	Controlled Flow per Drain (L/s)			Approximate Ponding Depth Above Drains (m)			Storage Volume Required (m ³)			Max. Storage Available (m ³)
			2 Yr	5 Yr	100 Yr	2 Yr	5 Yr	100 Yr	2 Yr	5 Yr	100 Yr	
A4-RD 1	1	RD-100-A-ADJ (Fully Exposed)	0.95	1.26	1.89	0.08	0.10	0.15	5.0	6.1	14.1	14.5
A4-RD 2	1	RD-100-A-ADJ (Fully Exposed)	0.95	1.26	1.89	0.08	0.10	0.15	5.2	7.1	14.6	15.4
Total Roof (0.075 ha)	2	-	1.9*	2.5*	3.8*	-	-	-	10.2*	13.9*	28.7*	29.9*

*Table represents rounded values

Refer to **Appendix E** for detailed SWM calculations and **Appendix G** for the control flow roof drain information.

2.3.4.6 Area A-5 – Controlled Flow from Office Tower Roof

The post-development flow from this sub-catchment area will be attenuated using Watts adjustable ‘Accutrol’ control flow roof drains (model number RD-100-A-ADJ) prior to being directed to the downstream storm sewer via the proposed building service.

Table 3.5 summarizes the post-development design flows from this sub-catchment area as well as the type of roof drains, the maximum anticipated ponding depths, storage volumes required and storage volumes provided for the 2-year, 5-year and 100-year design events.

Table 3.5: Controlled Flow Roof Drains

Roof Drain ID & Drainage Area (ha)	No. of Roof Drains	Watts Roof Drain Model ID (Weir Opening)	Controlled Flow per Drain (L/s)			Approximate Ponding Depth Above Drains (m)			Storage Volume Required (m ³)			Max. Storage Available (m ³)
			2 Yr	5 Yr	100 Yr	2 Yr	5 Yr	100 Yr	2 Yr	5 Yr	100 Yr	
A5-RD 1	1	RD-100-A-ADJ (Closed)	0.32	0.32	0.32	0.08	0.10	0.15	1.2	1.8	4.3	5.1
A5-RD 2	1	RD-100-A-ADJ (Closed)	0.32	0.32	0.32	0.08	0.10	0.15	1.9	2.9	6.6	7.1
A5-RD 3	1	RD-100-A-ADJ (Closed)	0.32	0.32	0.32	0.08	0.10	0.15	0.7	1.1	2.6	2.9

Roof Drain ID & Drainage Area (ha)	No. of Roof Drains	Watts Roof Drain Model ID (Weir Opening)	Controlled Flow per Drain (L/s)			Approximate Ponding Depth Above Drains (m)			Storage Volume Required (m ³)			Max. Storage Available (m ³)
			2 Yr	5 Yr	100 Yr	2 Yr	5 Yr	100 Yr	2 Yr	5 Yr	100 Yr	
A5-RD 4	1	RD-100-A-ADJ (Closed)	0.32	0.32	0.32	0.08	0.10	0.15	0.6	1.0	2.4	2.8
A5-RD 5	1	RD-100-A-ADJ (Closed)	0.32	0.32	0.32	0.08	0.10	0.15	0.8	1.3	3.1	3.3
A5-RD 6	1	RD-100-A-ADJ (Closed)	0.32	0.32	0.32	0.08	0.10	0.15	0.2	0.4	1.1	1.5
A5-RD 7	1	RD-100-A-ADJ (Closed)	0.32	0.32	0.32	0.08	0.10	0.15	1.5	2.3	5.3	5.7
A5-RD 8	1	RD-100-A-ADJ (Closed)	0.32	0.32	0.32	0.08	0.10	0.15	1.6	2.4	5.6	5.8
A5-RD 9	1	RD-100-A-ADJ (Closed)	0.32	0.32	0.32	0.08	0.10	0.15	1.3	2.0	4.8	5.0
A5-RD 10	1	RD-100-A-ADJ (Closed)	0.32	0.32	0.32	0.08	0.10	0.15	1.4	2.1	5.0	5.0
A5-RD 11	1	RD-100-A-ADJ (1/4 Exposed)	0.71	0.79	0.95	0.08	0.10	0.15	2.3	3.4	7.8	8.7
A5-RD 12	1	RD-100-A-ADJ (1/4 Exposed)	0.71	0.79	0.95	0.08	0.10	0.15	3.2	4.7	10.5	10.9
A5-RD 13	1	RD-100-A-ADJ (1/4 Exposed)	0.71	0.79	0.95	0.08	0.10	0.15	2.2	3.3	7.4	8.4
A5-RD 14	1	RD-100-A-ADJ (1/4 Exposed)	0.71	0.79	0.95	0.08	0.10	0.15	3.0	4.4	9.9	11.1
A5-RD 15	1	RD-100-A-ADJ (1/4 Exposed)	0.71	0.79	0.95	0.08	0.10	0.15	2.2	3.3	7.5	8.4
A5-RD 16	1	RD-100-A-ADJ (1/4 Exposed)	0.71	0.79	0.95	0.08	0.10	0.15	3.0	4.4	9.9	11.1
A5-RD 17	1	RD-100-A-ADJ (1/4 Exposed)	0.71	0.79	0.95	0.08	0.10	0.15	3.7	5.4	12.0	12.1
A5-RD 18	1	RD-100-A-ADJ (1/2 Exposed)	0.79	0.95	1.26	0.08	0.10	0.15	4.8	6.8	14.5	15.1
Total Roof (0.288 ha)	18	-	9.0*	9.7*	11.1*	-	-	-	35.8*	53.0*	120.6*	130.0*

*Table represents rounded values

Refer to **Appendix E** for detailed SWM calculations and **Appendix G** for the control flow roof drain information.

2.3.4.7 Area A-6 – Controlled Flow from Social Café and Amenity Roof

The post-development flow from this sub-catchment area will be attenuated using Watts adjustable ‘Accutrol’ control flow roof drains (model number RD-100-A-ADJ) prior to being directed to the downstream storm sewer via the proposed building service.

Table 3.6 summarizes the post-development design flows from this sub-catchment area as well as the type of roof drains, the maximum anticipated ponding depths, storage volumes required and storage volumes provided for the 2-year, 5-year and 100-year design events.

Table 3.6: Controlled Flow Roof Drains

Roof Drain ID & Drainage Area (ha)	No. of Roof Drains	Watts Roof Drain Model ID (Weir Opening)	Controlled Flow per Drain (L/s)			Approximate Ponding Depth Above Drains (m)			Storage Volume Required (m ³)			Max. Storage Available (m ³)
			2 Yr	5 Yr	100 Yr	2 Yr	5 Yr	100 Yr	2 Yr	5 Yr	100 Yr	
A6-RD 1	1	RD-100-A-ADJ (Closed)	0.32	0.32	0.32	0.08	0.10	0.15	1.3	2.0	4.8	8.6
A6-RD 2	1	RD-100-A-ADJ (1/4 Exposed)	0.71	0.79	0.95	0.08	0.10	0.15	4.1	5.9	13.0	16.6
A6-RD 3	1	RD-100-A-ADJ (Closed)	0.32	0.32	0.32	0.08	0.10	0.15	0.7	1.2	2.9	3.8
A6-RD 4	1	RD-100-A-ADJ (Closed)	0.32	0.32	0.32	0.08	0.10	0.15	0.7	1.1	2.8	3.8
A6-RD 5	1	RD-100-A-ADJ (Closed)	0.32	0.32	0.32	0.08	0.10	0.15	0.5	0.8	1.9	2.2
A6-RD 6	1	RD-100-A-ADJ (Closed)	0.32	0.32	0.32	0.08	0.10	0.15	0.4	0.7	1.9	2.2
A6-RD 7	1	RD-100-A-ADJ (1/4 Exposed)	0.71	0.79	0.95	0.08	0.10	0.15	2.7	4.0	9.0	9.2
A6-RD 8	1	RD-100-A-ADJ (1/4 Exposed)	0.71	0.79	0.95	0.08	0.10	0.15	2.7	3.9	8.9	9.3
Total Roof (0.117 ha)	8	-	3.7*	4.0*	4.5*	-	-	-	13.2*	19.6*	45.1*	55.7*

*Table represents rounded values

Refer to **Appendix E** for detailed SWM calculations and **Appendix G** for the control flow roof drain information.

2.3.4.8 Summary of Post- Development Flows to North Storm Outlet

As indicated in **Tables 3.1 to 3.6**, the respective sub-catchment areas will provide sufficient storage for the 2-year, 5-year and 100-year design events, whether underground, on the surface, or on the building roofs. The site has also been designed to ensure that no stormwater will pond on the paved surfaces during the 2-year storm event. Furthermore, the site grading design will ensure that surface ponding depths will not touch the building envelope or lowest building openings during the 100-year+20% stress test.

Table 3.7 compares the post-development site flows from the proposed development to the maximum allowable release rate for the 2-year, 5-year, and the 100-year design events.

Table 3.7: Stormwater Flow Comparison Table

Design Event	Pre-Development Conditions	Drainage Areas A-0 to A-6							
		Post-Development Conditions							
	Max Release Rate (L/s)	A-0 Flow (L/s)	A-1 Flow (L/s)	A-2 Flow (L/s)	A-3 Flow (L/s)	A-4 Flow (L/s)	A-5 Flow (L/s)	A-6 Flow (L/s)	Total Flow (L/s)
2-Yr	63.8	2.0	5.9	15.5	1.9	1.9	9.0	3.7	39.9
5-Yr		2.8	6.6	18.2	2.5	2.5	9.7	4.0	46.3
100-Yr		5.9	8.5	26.0	3.8	3.8	11.1	4.5	63.5

As indicated in the table above, the 2-year, 5-year and 100-year post-development flows will be less than the maximum allowable release rate for this portion of the site. Refer to **Appendix E** for detailed SWM calculations.

2.3.5 Post-Development Flows to South Outlet Sewer

To maintain consistency with the previously approved 'Stormwater Management Plan, Kanata Research Park Report'², post-development stormwater flows from sub-catchment Areas B-0 to B4 (570 March Road) and C-0 to C-2 (520 March Road) will be controlled to a maximum release rate of 235.1 L/s, prior to being released into southern storm sewer system located on the KRP lands.

2.3.5.1 Area B-0 – Uncontrolled Direct Runoff

The uncontrolled post-development flows from sub-catchment area B-0a, which sheet drain to Legget Drive, were calculated using the Rational Method to be approximately 2.0 L/s during the 2-year design event, 2.7 L/s during the 5-year design event and 5.7 L/s during the 100-year design event.

The uncontrolled post-development flows from sub-catchment area B-0b, which sheet drain to the adjacent Sanmina property (500 March Road), per existing conditions and to prevent impacts on the mature trees along the common property line, were calculated using the Rational Method to be approximately 3.7 L/s during the 2-year design event, 5.1 L/s during the 5-year design event and 10.6 L/s during the 100-year design event. Refer to the Post-Development Stormwater Management Plan (C-301) and **Appendix E** for detailed SWM calculations.

2.3.5.2 Area B-1 – Controlled Flow from R&D Lab Building

The post-development flow from this sub-catchment area will be captured by the Lab Building and Loading Dock roof drains and directed to an internal SWM storage tank. Stormwater collected within the internal SWM cistern will be controlled prior to being discharged into the existing 525mm dia. storm sewer in Legget Drive, via the storm service lateral. The post-development flows will be attenuated by an ICD installed in the outlet pipe of CBMH 266, which will also act as the emergency overflow from the tank to the surface outside the building. The internal plumbing is to be pressure rated piping specified by the mechanical engineer.

Table 3.8 summarizes the post-development design flow from this sub-catchment area as well as the ICD specifications, the anticipated ponding elevations, storage volumes required and storage volume provided for the 2-year, 5-year and 100-year design events.

Table 3.8: Stormwater Flows, ICD & Storage

Design Event	Controlled Site Flows from Area B-1					
	ICD Type	Peak Flow	Ponding Depth/Elev.	~Average Flow (50% Qpeak)	Storage Vol. Required*	Max Storage Provided
2-Year	Tempest HF Type C ICD	21.9 L/s	0.00 m (78.25 m)	11.0 L/s	137.1 m ³	~400 m ³
5-Year		27.2 L/s	0.00 m (78.38 m)	13.6 L/s	188.4 m ³	
100-Year		41.0 L/s	0.00 m (78.86 m)	20.5 L/s	380.0 m ³	

*Storage volumes are based on the 50% Qpeak flow rates, which generally represents the average flow.

Refer to **Appendix E** for detailed SWM calculations and to **Appendix F** for ICD information.

2.3.5.3 Area B-2 – Controlled Flow from Plaza and Entrance Dropoff

The post-development flow from this sub-catchment area will be attenuated by an ICD installed in the outlet pipe of CBMH 260. Stormwater runoff from this sub-catchment area will be temporarily stored in underground stormwater storage chambers, within the storm sewer system, and within the landscaped bioswales prior to being discharged into the downstream storm sewer system.

Table 3.9 summarizes the post-development design flow from this sub-catchment area as well as the ICD specifications, the anticipated ponding elevations, storage volumes required and storage volume provided for the 2-year, 5-year and 100-year design events.

Table 3.9: Stormwater Flows, ICD & Underground and Surface Storage

Design Event	Controlled Site Flows from Area B-2					
	ICD Type	Peak Flow	Ponding Depth/Elev.	~Average Flow (50% Qpeak)	Storage Vol. Required*	Max Storage Provided
2-Year	Tempest HF Type D ICD	31.9 L/s	0.00 m (79.81 m)	16.0 L/s	48.3 m ³	164.1 m ³
5-Year		35.8 L/s	0.00 m (80.00 m)	17.9 L/s	71.2 m ³	
100-Year		48.0 L/s	0.00 m (80.73 m)	24.0 L/s	159.1 m ³	

*Storage volumes are based on the 50% Qpeak flow rates, which generally represents the average flow.

Refer to **Appendix E** for detailed SWM calculations and to **Appendix F** for ICD information.

2.3.5.4 Area B-3 – Controlled Flow from Parking Structure and Driveway

The post-development flow from this sub-catchment area will be attenuated by an ICD installed in the outlet pipe of STMMH 110. Stormwater runoff from this sub-catchment area will be temporarily stored in underground stormwater storage chambers, within the storm sewer system, and potentially on the surface prior to being discharged into the downstream storm sewer system.

Table 3.10 summarizes the post-development design flow from this sub-catchment area as well as the ICD specifications, the anticipated ponding elevations, storage volumes required and storage volume provided for the 2-year, 5-year and 100-year design events.

Table 3.10: Stormwater Flows, ICD & Underground and Surface Storage

Design Event	Controlled Site Flows from Area B-3					
	ICD Type	Peak Flow	Ponding Depth/Elev.	~Average Flow (50% Qpeak)	Storage Vol. Required*	Max Storage Provided
2-Year	Tempest HF Type C ICD	23.7 L/s	0.00 m (78.64 m)	11.9 L/s	222.2 m ³	608.1 m ³
5-Year		29.8 L/s	0.00 m (78.79 m)	14.9 L/s	303.3 m ³	
100-Year		46.0 L/s	0.0 m (79.36 m)	23.0 L/s	603.6 m ³	

*Storage volumes are based on the 50% Qpeak flow rates, which generally represents the average flow.

Refer to **Appendix E** for detailed SWM calculations and to **Appendix F** for ICD information.

2.3.5.5 Area B-4 – Controlled Flow from South Access Route

The post-development flow from this sub-catchment area will be attenuated by an ICD installed in the outlet pipe of STMMH 116. Stormwater runoff from this sub-catchment area will be temporarily stored in underground stormwater storage chambers, within the storm sewer system, and potentially on the surface prior to being discharged into the downstream storm sewer system.

Table 3.11 summarizes the post-development design flow from this sub-catchment area as well as the ICD specifications, the anticipated ponding elevations, storage volumes required and storage volume provided for the 2-year, 5-year and 100-year design events.

Table 3.11: Stormwater Flows, ICD & Underground and Surface Storage

Design Event	Controlled Site Flows from Area B-4					
	ICD Type	Peak Flow	Ponding Depth/Elev.	~Average Flow (50% Qpeak)	Storage Vol. Required*	Max Storage Provided
2-Year	Tempest HF Type C ICD	23.9 L/s	0.00 m (78.11 m)	12.0 L/s	118.9 m ³	341.8 m ³
5-Year		28.8 L/s	0.00 m (78.26 m)	14.4 L/s	165.5 m ³	
100-Year		43.0 L/s	0.00 m (78.84 m)	21.5 L/s	336.3 m ³	

*Storage volumes are based on the 50% Qpeak flow rates, which generally represents the average flow.

Refer to **Appendix E** for detailed SWM calculations and to **Appendix F** for ICD information.

2.3.5.6 Area C-0 – Uncontrolled Direct Runoff from Access Route

The uncontrolled post-development flow from sub-catchment area C-0, which sheet drains to the adjacent Sanmina property (500 March Road) per existing conditions and to prevent impacts on the mature trees along the common property line, were calculated using the Rational Method to be approximately 2.7 L/s during the 2-year design event, 3.7 L/s during the 5-year design event and 9.5 L/s during the 100-year design event. Refer to the Post-Development Stormwater Management Plan (C-301) and **Appendix E** for detailed SWM calculations.

2.3.5.7 Area C-1 – Controlled Flow from the Retained Lands

The post-development flows from this sub-catchment area will be attenuated by an ICD installed in the outlet pipe of CB 208 and temporarily stored on the surface, prior to being discharged into the downstream storm sewer system, until the property is developed.

Table 3.12 summarizes the temporary post-development design flow from this sub-catchment area as well as the ICD specifications, the anticipated ponding elevations, storage volumes required and storage volume provided for the 2-year, 5-year and 100-year design events.

Table 3.12: Stormwater Flows, ICD & Internal SWM Storage

Design Event	Controlled Site Flows from Area C-1					
	ICD Type	Peak Flow	Ponding Depth/Elev.	~Average Flow (50% Qpeak)	Storage Vol. Required*	Max Storage Provided
2-Year	Tempest HF Type B ICD	26.1 L/s	0.17 m (80.17 m)	13.1 L/s	8.6 m ³	65.5 m ³
5-Year		26.5 L/s	0.21 m (80.21 m)	13.3 L/s	15.0 m ³	
100-Year		27.0 L/s	0.30 m (80.30 m)	13.5 L/s	49.6 m ³	

*Storage volumes are based on the 50% Qpeak flow rates, which generally represents the average flow.

Refer to **Appendix E** for detailed SWM calculations and **Appendix F** for ICD information.

2.3.5.8 Area C-2 – Controlled Flow from the Retained Lands ROW

The post-development flow from this sub-catchment area will be attenuated by an ICD installed in the outlet pipe of CBMH 261. Stormwater runoff from this sub-catchment area will be temporarily stored in underground stormwater storage chambers, within the storm sewer system, and potentially on the surface prior to being discharged into the downstream storm sewer system.

Table 3.13 summarizes the post-development design flow from this sub-catchment area as well as the ICD specifications, the anticipated ponding elevations, storage volumes required and storage volume provided for the 2-year, 5-year and 100-year design events.

Table 3.13: Stormwater Flows, ICD & Internal SWM Storage

Design Event	Controlled Site Flows from Area C-2					
	ICD Type	Peak Flow	Ponding Depth/Elev.	~Average Flow (50% Qpeak)	Storage Vol. Required*	Max Storage Provided
2-Year	Tempest Vortex LMF Model 100 ICD	1.6 L/s	0.00 m (78.62 m)	0.8 L/s	14.0 m ³	41.6 m ³
5-Year		2.0 L/s	0.00 m (78.76 m)	1.0 L/s	19.1 m ³	
100-Year		3.0 L/s	0.00 m (79.30 m)	1.5 L/s	38.4 m ³	

*Storage volumes are based on the 50% Qpeak flow rates, which generally represents the average flow.

Refer to **Appendix E** for detailed SWM calculations and to **Appendix F** for ICD information.

2.3.5.9 Summary of Post- Development Flows to South Stormwater Outlet

As indicated in **Tables 3.8 to 3.13**, the respective sub-catchment areas will provide sufficient storage for the 2-year, 5-year and 100-year design events, whether underground or on the grassed surface of the Retained Lands. The site has also been designed to ensure that no stormwater will pond on the paved surfaces during the 2-year storm event. Furthermore, the site grading design will ensure that surface ponding depths will not touch the building envelope or lowest building openings during the 100-year+20% stress test.

Table 3.14 compares the post-development site flows from the proposed development to the maximum allowable release rate for the 2-year, 5-year, and the 100-year design events.

Table 3.14: Stormwater Flow Comparison Table

Design Event	Pre-Dev. Conditions	Drainage Areas B and C								
		Post-Development Conditions								
	Max Release Rate (L/s)	B-0 Flow (L/s)	B-1 Flow (L/s)	B-2 Flow (L/s)	B-3 Flow (L/s)	B-4 Flow (L/s)	C-0 Flow (L/s)	C-1 Flow (L/s)	C-2 Flow (L/s)	Total Flow (L/s)
2-Yr	235.1 L/s	5.7	21.9	31.9	23.7	23.9	2.7	26.1	1.6	137.6
5-Yr		7.8	27.2	35.8	29.8	28.8	3.7	26.5	2.0	161.5
100-Yr		16.3	41.0	48.0	46.0	43.0	9.5	27.0	3.0	233.8

As indicated in the table above, the 2-year, 5-year and 100-year post-development flows will be less than the maximum allowable release rate for this portion of the site. Refer to **Appendix E** for detailed SWM calculations.

2.3.6 Stormwater Quality Control

Typically, stormwater quality control measures are required for drive aisles and paved parking areas. Building roofs and landscaped areas are generally considered clean for the purposes of water quality and aquatic habitat protection. The building roofs and landscaped areas comprise approximately 86% of the total site area. Nevertheless, on-site stormwater quality control will be provided based on recommendations from the MVCA.

On-site stormwater quality control will be achieved using a “treatment train”, with flows being treated by a combination of rain gardens in landscaped areas, bioswales in the front entrance and courtyard, and oil and grit separator (OGS) units installed at the site’s north and south stormwater outlets. Flows entering the municipal storm sewer system from the R&D Lab building will not require on-site stormwater quality control, as runoff from buildings roofs are deemed clean from a water quality perspective. Additional stormwater quality treatment will be provided by the existing downstream SWM Facility located on adjacent KRP lands, as outlined in the previously approved ‘Stormwater Management Plan, Kanata Research Park’². This design is consistent with the MVCA’s quality control recommendations, as outlined in the approved ‘Assessment of Adequacy of Public Services Report’⁴.

Most of the on-site parking will be provided within the 3-storey parking structure and stormwater runoff from the upper level of the parking garage and other paved areas, including the driveways, south service road and Lifestyle Street will be stored within underground SWM storage chambers. Stormwater runoff from the visitor parking area and central courtyard will be directed to nearby bioswales, thus eliminating the potential for stormwater management on the surface of paved parking lots prone to increase water temperatures. Furthermore, runoff from the R&D Lab roof will be directed to an internal SWM cistern. As a result, many thermal mitigation measures will be implemented into the overall SWM design per the recommendations outlined in the MVCA’s Shirley’s Brook 2016 Summary Report.

3.0 SITE GRADING

The existing site generally slopes in a northeastern direction from March Road down to Legget Drive. Under post-development conditions, the proposed Lifestyle Street ROW will slope down along the northwest property line from 82.63m at March Road to 79.81m at Legget Drive. The proposed service road at the south end of the subject site will drop from approximately 81.20m at March Road to 79.45m at Legget Drive. The finished floor elevations (FFE) of the proposed buildings have been set based on the existing topography and elevation of the internal roadways and will range from 82.50m (Office Tower, Parking Structure, Central Link and Courtyard), 82.25m (Retail West), 82.00m (R&D Lab Building) and 81.65m (Retail East). The major overland flow route is shown on the enclosed Grading and ESC Plan (C-200).

4.0 GEOTECHNICAL INVESTIGATIONS

The Geotechnical Investigation and Hydrogeological Assessment Report (No.: PG12606873-RPT-1), dated March 6, 2024, and associated Reliance Letter, dated September 5, 2024, have been prepared by GHD for the proposed development. Several water-tight measures have been implemented in the servicing design per recommendations from this report, including water-tight pipe joints, water-tight manhole frame and covers, non-woven geotextile around underground SWM tanks, and pipeline buoyancy mitigation measures where required. Refer to the Geotechnical Report⁵ and to the Reliance Letter⁶ for subsurface conditions, construction recommendations and geotechnical inspection requirements.

5.0 EROSION AND SEDIMENT CONTROL

To mitigate erosion and to prevent sediment from entering the storm sewer system, temporary erosion and sediment control measures will be implemented on-site during construction in accordance with the Best Management Practices for Erosion and Sediment Control. This includes the following temporary measures:

- Filter bags / catch basin inserts (sediment sacks) will be placed under the grates of nearby catchbasins and manholes and will remain in place until vegetation has been established and construction is completed.
- Silt fencing will be placed per OPSS 577 and OPSD 219.110 along the surrounding construction limits.
- Mud mats will be installed at the site entrances.
- Street sweeping and cleaning will be performed, as required, to suppress dust and to provide safe and clean roadways adjacent to the construction site.
- On-site dewatering is to be directed to a sediment trap and/or gravel splash pad and discharged safely to an approved outlet as directed by the engineer.
- Any stockpiled material will be properly managed to prevent those materials from entering the sewer system and/or the downstream ditch or watercourse.

The temporary erosion and sediment control measures will be implemented prior to construction and will remain in place during all phases of construction. Regular inspection and maintenance of the erosion control measures will be undertaken.

6.0 CONCLUSION

This report has been prepared in support of a Site Plan Control application for the proposed Nokia Ottawa Innovation Campus located at 570 and Retained Lands parcel located at 520 March Road. The conclusions are as follows:

- Sanitary flows from the buildings will be directed to the private sanitary sewers and/or directly to the municipal sanitary sewer in Legget Drive. This will be facilitated by extending the 250mm dia. sanitary sewer along Legget Drive and installing new private 250mm dia. sanitary sewers in the proposed Lifestyle Street and south service road.
- Water servicing for domestic use and fire protection will be provided by a new private looped watermain network. The looped watermain will be fed off the existing 610mm dia. feeder main in Legget Drive. **Adequate water supply and system pressures will exist throughout the watermain network under the specified 'Max Day + Fire Flow' and 'Peak Hour' conditions.**
- The proposed Nokia buildings, excluding the open-air parking garage, will be fully sprinklered. For the purpose of the watermain network analysis, it is assumed that the future building on the Retained Lands parcel will also be fully sprinklered.
- The proposed stormwater design control measures will reduce peak flows into the storm sewer system.
 - Post-development flow from sub-catchment areas A-1 and A-2 will be controlled by inlet control devices (ICD) installed within the on-site storm sewer system, while flows from the building roofs area A-3 to A-6 will be attenuated by control flow roof drains.
 - Post-development flow from sub-catchment area B-1 will be directed to an internal SWM tank and controlled prior to being discharged into the 525mm dia. municipal storm sewer in Legget Drive, via the building service.
 - Post-development flow from sub-catchment areas B-1 to B-4 and C-1 to C-2 will be controlled by ICDs installed within the on-site storm sewer system.

- The total post-development flow from the northern portion of the subject site will be approximately 39.9 L/s during the 2-year design event, 46.3 L/s during the 5-year event and 63.5 L/s during the 100-year event, all less than the maximum allowable release rate of 63.8 L/s.
- The total post-development flow from the southern portion of the subject site will be approximately 137.6 L/s during the 2-year design event, 161.5 L/s during the 5-year event and 233.8 L/s during the 100-year event, all less than the maximum allowable release rate of 235.1 L/s. All post-development flows are also significantly reduced when compared to current uncontrolled conditions.
- Regular inspection and maintenance of the storm sewer system, including the inlet control devices, control flow roof drains and internal SWM cistern is recommended to ensure that the storm drainage system is clean and operational.
- Erosion and sediment controls are to be provided during construction.

It is recommended that the proposed site servicing and stormwater management design be approved for implementation.

NOVATECH

Prepared by:

François Thauvette, P. Eng.
Senior Project Manager

APPENDIX A
Project Correspondence

Pre-Application Consultation Site Plan Control

570 March Road

Meeting Date: 2023.02.08

Owner: Nokia Canada Inc.
Applicant: Peter Henley, First Gulf

Ward: 4 – Kanata North
Councillor: Cathy Curry

Proposal Summary: To permit the development of the new Nokia Canada corporate headquarters and office.

Attendees: Internal

Krishon Walker, Planner II, Economic Development Services
Nader Kadri, Planner II, Public Realm and Urban Design
Max Walker, Sr. Project Manager, Transportation Planning
Mike Giampa, Sr. Transportation Project Manager, Planning Services
Adwoa Achireko, Planner (*coop*), Planning Services
Samuel Farkas, Planner (*coop*), Planning Services

External

Peter Henley, Development Manager, First Gulf
Peter Nikolakakos, EVP, Development & Planning, First Gulf
Andrew Srgo, Director, Development at First Gulf Corporation
Aaron Clodd, Director, Development Management, Colliers

Meeting Notes

Planning Comments (Provided by Krishon Walker)

- The site is located within the City's Suburban Transect as outlined on Schedule A – Transect Policy Areas of the Official Plan, is designated Kanata North Economic District on Schedule B5 – Suburban (West) Transect of the Official Plan (the Plan) and is along the March Road Mainstreet Corridor. The Kanata North Economic District is one of two Special Economic Districts identified in the Plan and is intended to support the City's economic development and growth.
- The site is currently zoned as Mixed-Use Centre Zone, Urban Exception 2816, Holding Provision (MC[2816]-h) and is currently subject to a Zoning By-law Amendment application which is scheduled to be considered by the Planning and Housing Committee on February 27, 2023, and City Council on March 8, 2023. Please ensure that your proposal complies with all applicable provisions under the Zoning By-law.
- Given that the proposed site redevelopment is a significant development initiative that support the City's Economic Development Strategy and city building priorities and has identified by the as a High Economic Impact Project (HEIP). As such, it will be managed by the Economic Development Services team.
- Please ensure that Site Plan clearly show:
 - Title, location and date of the project. The title and location referenced on plans and studies should be consistent.

- The name and address of the owner and applicant, architect(s), designer(s), engineer(s) and surveyor(s) with their full address including Postal Code and telephone number.
- Legend (including bar scale and written ratio scale in metric, and any graphic symbols used) on the plan.
- North arrow (orientated to the top of the page).
- Area of site, and bearings and lengths of all property lines.
- Clear delineation of limit of site development and existing features within 5 metres of limit. This includes the retained parcel along March Road as a driveway is proposed to run across that site.
- Location of buildings, site features and landscape elements on adjacent land and in the public right-of ways.
- Existing features to be retained, removed or relocated.
- Areas labelled by function or type (landscape areas, parking areas, access points, etc.).
- Proposed fire route and fire route sign locations.
- Dimensions of all proposed buildings, roads, radii of turns, overhead clearances, parking areas with defined parking spaces, steps, terraces, fences, walks, aisles and private approaches (driveways).
- Dimensions required for zoning compliance.
- Gross floor area of all buildings.
- Location of snow storage. Storage shall not interfere with approved grading and drainage patterns or servicing. If snow is to be removed from the site, then please make a note of that on the Site Plan and include where the snow will be placed in the interim. Temporary snow storage areas should not conflict with utility box, landscaping, required parking, and site circulation.
- Waste management and recycling enclosure location and design details
- Pedestrian walking areas and surface treatment/materials
- Please ensure that Landscape Plan clearly show:
 - Title, location and date of the project. The title and location referenced on plans and studies should be consistent.
 - The name and address of the owner and applicant, architect(s), designer(s), engineer(s) and surveyor(s) with their full address including Postal Code and telephone number.
 - Legend (including bar scale and written ratio scale in metric, and any graphic symbols used) on the plan.
 - North arrow (orientated to the top of the page).
 - Existing plant material to be retained, removed or relocated on site and within the road allowance:
 - In a table, include species type, size and condition of all existing plant material.
 - Describe and/or illustrate the conservation methods during and after construction.
 - Proposed vegetation – trees, shrubs, ground covers to be planted on site and within the road allowance:
 - In a table, list each species including its common and botanical names, size, total quantity, and its condition or special requirements (example - bare root, 4" pot, 2-year old stock etc.).
 - Location of existing and proposed site features including, electrical transformer boxes, utility pedestals, light standards, overhead wires, or below grade services, mail boxes, bus stops, snow storage areas, waste management and recycling enclosure, or other features that may impact on the location of landscape elements.
 - Location, materials, dimensions and design details of existing and proposed landscape elements such as retaining walls, railings, site furniture, decorative and acoustical fencing, gateways features, signs, etc.

- Location of buildings, site features and landscaping on adjacent land and in the public right-of ways.
 - Note and/or dimension any offsets from site features and landscape elements required for technical reasons or zoning compliance.
 - Turf areas noting seed, sod or other treatments.
 - Pedestrian walking areas and surface treatment/materials.
- As you are proposing to have a driveway across the retained parcel along March Road, you will need to establish an easement across the site. Please consider reorienting that driveway so that it does not run across the entire frontage of that site, limiting access via March Road.

Feel free to contact Krishon Walker at Krishon.Walker@ottawa.ca for follow-up questions.

Urban Design Comments (Provided by Nader Kadri)

General Comment

- The site is with a Design Priority Area. You are encouraged visit to the UDRP even though a visit to the UDRP is not required for properties within the Kanata North Economic District.
- A Design Brief required. Please refer to the attached Terms of Reference.

Public Realm

- Treatment of the building along proposed “lifestyle street” appropriate. Would like additional details on how the lifestyle street, including cross sections and paver treatment patterns.
- Per the criteria in OP, there needs to be more consideration to how the development interacts with the existing public streets. As proposed, the development turns it back on March Road and Legget Drive. Recommend at-grade retail or non-residential uses (amenity for office users). For areas where this is not possible, consider green walls and murals. See examples below:

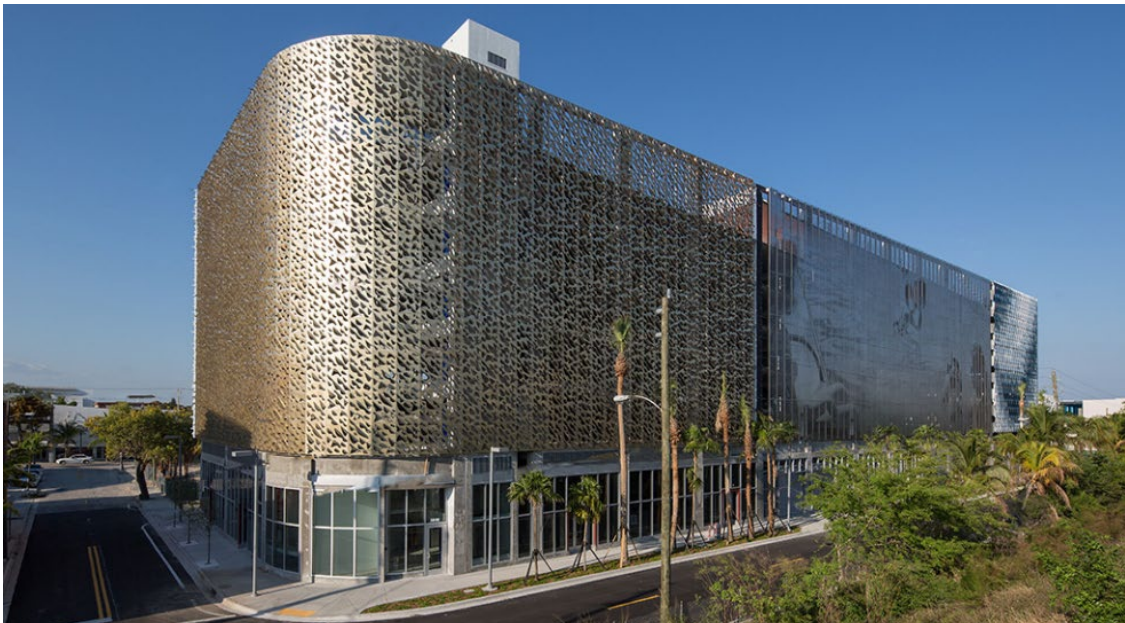

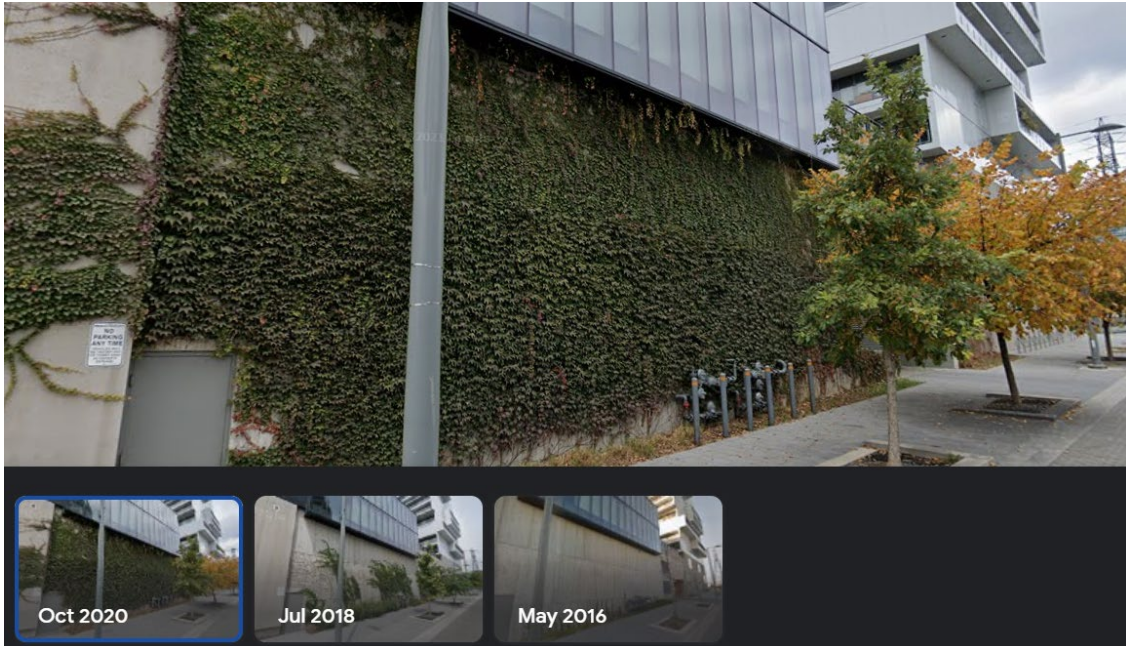

- Public realm treatment needed – please refer to criteria in the OP for March Road and Legget Drive.
 - Sidewalk details needed – please go beyond the 2 metre minimum.
 - The March Road connection is especially important in the context of the Phase 2 commercial parcel.
 - Recommend heavy planting between the building and the sidewalk in addition to the double alley of trees contemplated through the OPA.
- Per the OP, surface parking in and around the pick-up drop off area along March Road needs to be removed. This area should be treated like a woonerf.
- Details on the equipment yard, and its relationship to Legget Drive are needed.

Public Realm

- Appreciate the three dimensionality of the façades.
- Please detail sustainability strategy as part of your formal submission.
- Explore the potential for additional green roofs.

Feel free to contact Nader Kadri at Nader.Kadri@ottawa.ca for follow-up questions.

Transportation Comments (Provided by Mike Giampa)

- An updated TIA is required.

Feel free to contact Mike Giampa at Mike.Giampa@ottawa.ca for follow-up questions.

Transportation Planning Comments (Provided by Max Walker)

- By over-providing parking spaces and a full-access intersection along March Road, we continue to encourage vehicular usage and maintain the existing transportation equilibrium rather than supporting the City's investment in transit, i.e. the March Rd BRT. By increasing the friction and cost of driving at the source, i.e. reduced parking spaces and convenience of vehicular use, we are working toward achieving a balance between modes of transportation and providing an incentive to reduce the total travel time of journeys, help create a city of proximity, reduce the equity gap and minimize the ecological footprint of transportation.

- We look forward to reviewing an updated TIA to better understand the site's mobility patterns. For the area within 600m of transit stations, it is suggested that they proceed with typical TOD modal shares(15% Auto; 5% Auto Passenger, 65 %Transit, 15% Other).
- To support the shift towards sustainable transportation modes and build healthy communities, we must also provide positive incentives to encourage the adoption of a car-free lifestyle. This could mean breaking up the superblocks on both sides of the street through an active transportation connection and ensuring the continuity of the 'lifestyle street'.

Feel free to contact Max Walker at Max.Walker@ottawa.ca for follow-up questions.

Application Submission Information

Application Type: **Complex – Manager’s Approval**

Site plan control application approval timelines vary based on the development complexity, scale, the quality of the submission and public consultation process if applicable. The legislated timeline under the Planning Act is 60 days. For more information on standard processing timelines, please visit: <https://ottawa.ca/en/city-hall/planning-and-development/information-developers/development-application-review-process/development-application-submission/development-application-forms#site-plan-control>

Prior to submitting a formal application, it is recommended that you pre-consult with the Ward Councillor, Cathy Curry.

For information on application fees, please visit: <https://ottawa.ca/en/city-hall/planning-and-development/information-developers/development-application-review-process/development-application-submission/fees-and-funding-programs/development-application-fees>

To request City of Ottawa plan(s) or report information please contact the City of Ottawa Information Centre: InformationCentre@ottawa.ca or (613) 580-2424 ext. 44455

Application Submission Requirements

For information on the preparation of Studies and Plans and the City’s requirements, please visit: <https://ottawa.ca/en/city-hall/planning-and-development/information-developers/development-application-review-process/development-application-submission/guide-preparing-studies-and-plans>

Please provide electronic copies (PDF) of all plans and studies required. Hard copies are not required at this time.

Note that many of the plans and studies collected with this application must be signed, sealed and dated by a qualified engineer, architect, surveyor, planner or designated specialist.

Francois Thauvette

From: Andrew Sgro <asgro@firstgulf.com>
Sent: Tuesday, November 7, 2023 11:45 AM
To: Francois Thauvette
Cc: Peter Henley; Peter Nikolakakos
Subject: Nokia - Updated Municipal Pre-Con Comments

Francois – see below for the updated comments from the City:

Apologies, there seemed to be some confusion between sites.

The watermain pre-consultation notes should have been in keeping with the February 2, 2022 Notes, and the following would apply to water:

- a) A new local watermain will be required on Legget Drive. Connection to the 610mm diameter transmission watermain will not be permitted. A water boundary condition request is needed for any new water connection to the City main.
- b) Existing watermain connections may be considered for interim phasing. Further comments to be provided at the Site Plan Control stage.
- c) As per Section 4.4.7.2 of the Ottawa Design Guidelines – Water Distribution, a DMA (District Metering Area) chamber will be required for private developments serviced by a connection 150mm or larger.
- d) Water Boundary condition requests must include the location of the service and the expected loads required by the proposed development.

Sanitary should have read:

Sanitary Infrastructure:

- a) A new local sanitary sewer will be required on Legget Drive. The 750 mm sanitary sewer on Legget Drive, south of Solandt Road, should have capacity to accommodate this redevelopment. Additional information on sewer capacity will be available once the Wastewater Master Plan is complete (anticipated June 2022).
- b) Existing sanitary connections may be considered for interim phasing. Further comments to be provided at the Site Plan Control stage.
- c) The City would not accept a development of this scale to outlet to the private sanitary sewer that currently exists east of Legget Drive, through the Kanata Research Park lands.

Stormwater Management Criteria:

For the subject site, is to be based on the following: a) Please refer to following background reports: Planning, Infrastructure and Economic Development Department Services de la planification, de l'infrastructure et du développement économique a. Shirley's Brook and Watts Creek Subwatershed Study, prepared by Dillon Consulting Ltd., 1999 b. Kanata Research Park, Storm Water Management Report, prepared by Novatech, dated June 1987 c. Stormwater Management Plan, Kanata Research Park, City of Kanata, prepared by Novatech, dated April 2000 d. Kanata Research Park Subdivision Design Brief, prepared by Novatech, dated August 2000 The stormwater management criteria shall be in

accordance with the minor and major system storm allocations presented in the above mentioned reports.

b) If the capacity of the receiving storm sewer is in question, over-controlling may be required, in which case all runoff must be controlled to the 2-year predevelopment level, and all flow depth must be controlled on-site. In such a case the pre-development condition will be determined using the smaller of a runoff coefficient of 0.5 or the actual existing site runoff coefficient.

c) Quality control to be provided as specified by the MVCA. d) Review of the existing legal agreements related to the private SWM pond outlet located to the east on KRP lands will be reviewed at the Site Plan Control stage.

Sorry for the confusion, the notes provided had been miss-filed.

Thanks,

Eric Surprenant, CET

Sr, Project Manager, Infrastructure Projects, West

Planning, Real Estate & Economic Development

613 580-2424 ext.: 27794

FIRST GULF

Andrew Sgro

Director Development

T: 416.773.7140 **C:** 437.223.6027

351 King Street East, 13th Floor

Toronto, ON, Canada M5A 0L6

Please do not feel obliged to reply to this email outside of your normal working hours.

APPENDIX B
Development Servicing Study Checklist

Servicing study guidelines for development applications

4. Development Servicing Study Checklist

The following section describes the checklist of the required content of servicing studies. It is expected that the proponent will address each one of the following items for the study to be deemed complete and ready for review by City of Ottawa Infrastructure Approvals staff.

The level of required detail in the Servicing Study will increase depending on the type of application. For example, for Official Plan amendments and re-zoning applications, the main issues will be to determine the capacity requirements for the proposed change in land use and confirm this against the existing capacity constraint, and to define the solutions, phasing of works and the financing of works to address the capacity constraint. For subdivisions and site plans, the above will be required with additional detailed information supporting the servicing within the development boundary.

4.1 General Content

- Executive Summary (for larger reports only).
- Date and revision number of the report.
- Location map and plan showing municipal address, boundary, and layout of proposed development.
- Plan showing the site and location of all existing services.
- Development statistics, land use, density, adherence to zoning and official plan, and reference to applicable subwatershed and watershed plans that provide context to which individual developments must adhere.
- Summary of Pre-consultation Meetings with City and other approval agencies.
- Reference and confirm conformance to higher level studies and reports (Master Servicing Studies, Environmental Assessments, Community Design Plans), or in the case where it is not in conformance, the proponent must provide justification and develop a defensible design criteria.
- Statement of objectives and servicing criteria.
- Identification of existing and proposed infrastructure available in the immediate area.
- Identification of Environmentally Significant Areas, watercourses and Municipal Drains potentially impacted by the proposed development (Reference can be made to the Natural Heritage Studies, if available).
- Concept level master grading plan to confirm existing and proposed grades in the development. This is required to confirm the feasibility of proposed stormwater management and drainage, soil removal and fill constraints, and potential impacts to neighbouring properties. This is also required to confirm that the proposed grading will not impede existing major system flow paths.
- Identification of potential impacts of proposed piped services on private services (such as wells and septic fields on adjacent lands) and mitigation required to address potential impacts.
- Proposed phasing of the development, if applicable.

- Reference to geotechnical studies and recommendations concerning servicing.

- All preliminary and formal site plan submissions should have the following information:
 - Metric scale

 - North arrow (including construction North)

 - Key plan

 - Name and contact information of applicant and property owner

 - Property limits including bearings and dimensions

 - Existing and proposed structures and parking areas

 - Easements, road widening and rights-of-way

 - Adjacent street names

4.2 Development Servicing Report: Water

- Confirm consistency with Master Servicing Study, if available
- Availability of public infrastructure to service proposed development
- Identification of system constraints
- Identify boundary conditions
- Confirmation of adequate domestic supply and pressure
- Confirmation of adequate fire flow protection and confirmation that fire flow is calculated as per the Fire Underwriter's Survey. Output should show available fire flow at locations throughout the development.
- Provide a check of high pressures. If pressure is found to be high, an assessment is required to confirm the application of pressure reducing valves.
- Definition of phasing constraints. Hydraulic modeling is required to confirm servicing for all defined phases of the project including the ultimate design
- Address reliability requirements such as appropriate location of shut-off valves
- Check on the necessity of a pressure zone boundary modification.
- Reference to water supply analysis to show that major infrastructure is capable of delivering sufficient water for the proposed land use. This includes data that shows that the expected demands under average day, peak hour and fire flow conditions provide water within the required pressure range

- Description of the proposed water distribution network, including locations of proposed connections to the existing system, provisions for necessary looping, and appurtenances (valves, pressure reducing valves, valve chambers, and fire hydrants) including special metering provisions.
- Description of off-site required feeder mains, booster pumping stations, and other water infrastructure that will be ultimately required to service proposed development, including financing, interim facilities, and timing of implementation.
- Confirmation that water demands are calculated based on the City of Ottawa Design Guidelines.
- Provision of a model schematic showing the boundary conditions locations, streets, parcels, and building locations for reference.

4.3 Development Servicing Report: Wastewater

- Summary of proposed design criteria (Note: Wet-weather flow criteria should not deviate from the City of Ottawa Sewer Design Guidelines. Monitored flow data from relatively new infrastructure cannot be used to justify capacity requirements for proposed infrastructure).
- Confirm consistency with Master Servicing Study and/or justifications for deviations.
- Consideration of local conditions that may contribute to extraneous flows that are higher than the recommended flows in the guidelines. This includes groundwater and soil conditions, and age and condition of sewers.
- Description of existing sanitary sewer available for discharge of wastewater from proposed development.
- Verify available capacity in downstream sanitary sewer and/or identification of upgrades necessary to service the proposed development. (Reference can be made to previously completed Master Servicing Study if applicable)
- Calculations related to dry-weather and wet-weather flow rates from the development in standard MOE sanitary sewer design table (Appendix 'C') format.
- Description of proposed sewer network including sewers, pumping stations, and forcemains.
- Discussion of previously identified environmental constraints and impact on servicing (environmental constraints are related to limitations imposed on the development in order to preserve the physical condition of watercourses, vegetation, soil cover, as well as protecting against water quantity and quality).
- Pumping stations: impacts of proposed development on existing pumping stations or requirements for new pumping station to service development.
- Forcemain capacity in terms of operational redundancy, surge pressure and maximum flow velocity.
- Identification and implementation of the emergency overflow from sanitary pumping stations in relation to the hydraulic grade line to protect against basement flooding.
- Special considerations such as contamination, corrosive environment etc.

4.4 Development Servicing Report: Stormwater Checklist

- Description of drainage outlets and downstream constraints including legality of outlets (i.e. municipal drain, right-of-way, watercourse, or private property)
- Analysis of available capacity in existing public infrastructure.
- A drawing showing the subject lands, its surroundings, the receiving watercourse, existing drainage patterns, and proposed drainage pattern.
- Water quantity control objective (e.g. controlling post-development peak flows to pre-development level for storm events ranging from the 2 or 5 year event (dependent on the receiving sewer design) to 100 year return period); if other objectives are being applied, a rationale must be included with reference to hydrologic analyses of the potentially affected subwatersheds, taking into account long-term cumulative effects.
- Water Quality control objective (basic, normal or enhanced level of protection based on the sensitivities of the receiving watercourse) and storage requirements.
- Description of the stormwater management concept with facility locations and descriptions with references and supporting information.
- Set-back from private sewage disposal systems.
- Watercourse and hazard lands setbacks.
- Record of pre-consultation with the Ontario Ministry of Environment and the Conservation Authority that has jurisdiction on the affected watershed.
- Confirm consistency with sub-watershed and Master Servicing Study, if applicable study exists.
- Storage requirements (complete with calculations) and conveyance capacity for minor events (1:5 year return period) and major events (1:100 year return period).
- Identification of watercourses within the proposed development and how watercourses will be protected, or, if necessary, altered by the proposed development with applicable approvals.
- Calculate pre and post development peak flow rates including a description of existing site conditions and proposed impervious areas and drainage catchments in comparison to existing conditions.
- Any proposed diversion of drainage catchment areas from one outlet to another.
- Proposed minor and major systems including locations and sizes of stormwater trunk sewers, and stormwater management facilities.
- If quantity control is not proposed, demonstration that downstream system has adequate capacity for the post-development flows up to and including the 100 year return period storm event.
- Identification of potential impacts to receiving watercourses
- Identification of municipal drains and related approval requirements.
- Descriptions of how the conveyance and storage capacity will be achieved for the development.
- 100 year flood levels and major flow routing to protect proposed development from flooding for establishing minimum building elevations (MBE) and overall grading.

- Inclusion of hydraulic analysis including hydraulic grade line elevations.
- Description of approach to erosion and sediment control during construction for the protection of receiving watercourse or drainage corridors.
- Identification of floodplains – proponent to obtain relevant floodplain information from the appropriate Conservation Authority. The proponent may be required to delineate floodplain elevations to the satisfaction of the Conservation Authority if such information is not available or if information does not match current conditions.
- Identification of fill constraints related to floodplain and geotechnical investigation.

4.5 Approval and Permit Requirements: Checklist

The Servicing Study shall provide a list of applicable permits and regulatory approvals necessary for the proposed development as well as the relevant issues affecting each approval. The approval and permitting shall include but not be limited to the following:

- Conservation Authority as the designated approval agency for modification of floodplain, potential impact on fish habitat, proposed works in or adjacent to a watercourse, cut/fill permits and Approval under Lakes and Rivers Improvement Act. The Conservation Authority is not the approval authority for the Lakes and Rivers Improvement Act. Where there are Conservation Authority regulations in place, approval under the Lakes and Rivers Improvement Act is not required, except in cases of dams as defined in the Act.
- Application for Certificate of Approval (CofA) under the Ontario Water Resources Act.
- Changes to Municipal Drains.
- Other permits (National Capital Commission, Parks Canada, Public Works and Government Services Canada, Ministry of Transportation etc.)

4.6 Conclusion Checklist

- Clearly stated conclusions and recommendations
- Comments received from review agencies including the City of Ottawa and information on how the comments were addressed. Final sign-off from the responsible reviewing agency.
- All draft and final reports shall be signed and stamped by a professional Engineer registered in Ontario

APPENDIX C

Sanitary Sewage Calculations, Sanitary Sewer Design Sheet

570 & 520 March Road - Nokia Innovation Campus
Summary
SANITARY SEWAGE ANALYSIS

Nokia Campus Peak Sanitary Flow		
8-Storey Office Tower	1.01	L/s
1-Storey Retail West	0.37	L/s
Upper Lifestyle Street + Plaza	0.19	L/s
Subtotal - Retail West Outlet	1.57	L/s
1-Storey Retail East	0.30	L/s
2-Storey Social Café	0.41	L/s
Lower Lifestyle Street	0.06	L/s
Subtotal - Retail East Outlet	0.77	L/s
5-Storey R&D Lab Building	1.06	L/s
Subtotal - R&D Lab Outlet	1.06	L/s
3-Storey Parking Garage	0.31	L/s
Access Road + Workyard	0.40	L/s
Subtotal - Parking Garage Outlet	0.71	L/s
Future Development	0.91	L/s
Subtotal - Retained Lands Outlet	0.91	L/s
Right-of-Ways	0.65	L/s
Subtotal - Other Site Infiltration	0.65	L/s
Total Peak Sanitary Flow	5.67	L/s

570 March Road - Nokia Innovation Campus
8-Storey Office Tower
SANITARY SEWAGE ANALYSIS

Nokia Campus - Office Tower		
Office Design Population	700	
Average Daily Sanitary Flows	75	L/person/day
Peaking Factor	1.50	
Peak Office Flows	0.91	L/s
Extraneous Flow		
Area	0.285	ha
Infiltration Allowance	0.33	L/s/ha
Peak Extraneous Flows	0.09	L/s
Total Peak Sanitary Flow	1.01	L/s

570 March Road - Nokia Innovation Campus
1-Storey Retail West
SANITARY SEWAGE ANALYSIS

Nokia Campus - Retail West Commercial		
Quick Service Design Population	50	seats (used 3x/day)
Average Daily Sanitary Flows	125	L/seat/day
Peaking Factor	1.5	
Peak Commercial Flows	0.33	L/s
Extraneous Flow		
Area	0.135	ha
Infiltration Allowance	0.33	L/s/ha
Peak Extraneous Flows	0.04	L/s
Total Peak Sanitary Flow	0.37	L/s

570 March Road - Nokia Innovation Campus
1-Storey Retail East
SANITARY SEWAGE ANALYSIS

Nokia Campus - Retail East Commercial		
Gym Design Population	200	Users (2x day)
Average Daily Sanitary Flows	40	L/user/day
Peaking Factor	1.5	
Peak Commercial Flows	0.28	L/s
Extraneous Flow		
Area	0.073	ha
Infiltration Allowance	0.33	L/s/ha
Peak Extraneous Flows	0.02	L/s
Total Peak Sanitary Flow	0.30	L/s

570 March Road - Nokia Innovation Campus
2-Storey Social Café
SANITARY SEWAGE ANALYSIS

Nokia Campus - Social Café		
Quick Service Design Population	50	seats (used 3x/day)
Average Daily Sanitary Flows	125	L/seat/day
Peaking Factor	1.5	
Peak Commercial Flows	0.33	L/s
Extraneous Flow		
Area	0.250	ha
Infiltration Allowance	0.33	L/s/ha
Peak Extraneous Flows	0.08	L/s
Total Peak Sanitary Flow	0.41	L/s

570 March Road - Nokia Innovation Campus
5-Storey R&D Lab Building
SANITARY SEWAGE ANALYSIS

R&D Lab Building		
Design Population	600	
Average Daily Sanitary Flows	75	L/person/day
Peaking Factor	1.50	
Peak Office Flows	0.78	L/s
Extraneous Flow		
Area	0.832	ha
Infiltration Allowance	0.33	L/s/ha
Peak Extraneous Flows	0.27	L/s
Total Peak Sanitary Flow	1.06	L/s

570 March Road - Nokia Innovation Campus
3-Storey Parking Garage
SANITARY SEWAGE ANALYSIS

Extraneous Flow		
Area	0.953	ha
Infiltration Allowance	0.33	L/s/ha
Peak Extraneous Flows	0.31	L/s
Total Peak Sanitary Flow	0.31	L/s

570 March Road - Nokia Innovation Campus
Right-of-Ways
SANITARY SEWAGE ANALYSIS

Upper Lifestyle Street + Plaza		
Area	0.590	ha
Infiltration Allowance	0.33	L/s/ha
Peak Extraneous Flows	0.19	L/s
Lower Lifestyle Street		
Area	0.184	ha
Infiltration Allowance	0.33	L/s/ha
Peak Extraneous Flows	0.06	L/s
Access Road + Workyard		
Area	1.199	ha
Infiltration Allowance	0.33	L/s/ha
Peak Extraneous Flows	0.40	L/s
Total Peak Sanitary Flow	0.65	L/s

**520 March Road - Retained Lands
Future Development
SANITARY SEWAGE ANALYSIS**

Retained Lands - Potential Future Office		
Office Design Population	500	
Average Daily Sanitary Flows	75	L/person/day
Peaking Factor	1.50	
Peak Office Flows	0.65	L/s
Extraneous Flow		
Area	0.777	ha
Infiltration Allowance	0.33	L/s/ha
Peak Extraneous Flows	0.26	L/s
Total Peak Sanitary Flow	0.91	L/s

SANITARY TRUNK SEWER Sanitary Sewer Design Sheet

PROJECT : 123043
 DESIGNED BY: KD
 CHECKED BY: FST
 DATE: 11/14/2024



LOCATION			INDIVIDUAL		CUMULATIVE		PEAK FLOWS				PROPOSED SEWER					
AREA	FROM MH	TO MH	FLOW RATE (L/s)	Infiltration Area (ha)	FLOW RATE (L/s)	Infiltration Area (ha)	PEAK FACTOR M	PEAK FLOW Q (p) (L/s)	PEAK EXTRAN.FLOW Q(i) (L/s)	PEAK DESIGN FLOW Q (d) (L/s)	LENGTH (m)	PIPE SIZE (mm)	TYPE OF PIPE	GRADE %	CAPACITY (L/s)	FULL FLOW VELOCITY (m/s)
Lifestyle Street	SAN MH 1	SAN MH 2	0.00	0.00	0.00	0.00	1.5	0.00	0.00	0.00	21.7	250	PVC	0.35	36.70	0.72
Office Tower + Retail West Upper Lifestyle Street + Plaza	NOKIA-1	SAN MH 2	0.83	0.42	0.83	1.01	1.5	1.24	0.33	1.57	9.9	200	PVC	1.00	34.22	1.06
			0.00	0.59												
Lifestyle Street	SAN MH 2	SAN MH 3	0.00	0.00	0.83	1.01	1.5	1.24	0.33	1.57	15.0	250	PVC	0.35	36.70	0.72
	SAN MH 3	SAN MH 4	0.00	0.00	0.83	1.01	1.5	1.24	0.33	1.57	37.6	250	PVC	0.35	36.70	0.72
	SAN MH 4	SAN MH 5	0.00	0.00	0.83	1.01	1.5	1.24	0.33	1.57	18.5	250	PVC	0.35	36.70	0.72
Social Café + Retail East Lower Lifestyle Street	NOKIA-2	SAN MH 5	0.40	0.32	0.40	0.51	1.5	0.60	0.17	0.77	12.6	200	PVC	1.00	34.22	1.06
			0.00	0.19												
Lifestyle Street	SAN MH 5	SAN MH 5a	0.00	0.00	1.23	1.52	1.5	1.84	0.50	2.34	37.2	250	PVC	0.35	36.70	0.72
	SAN MH 5a	SAN MH 6	0.00	0.00	1.23	1.52	1.5	1.84	0.50	2.34	13.8	250	PVC	0.35	36.70	0.72
Legget-1	SAN MH 6	EX SAN MH A	0.00	0.34	1.23	1.86	1.5	1.84	0.61	2.46	113.2	250	PVC	0.35	36.70	0.72
R&D Lab	NOKIA-3	SAN MH 12	0.52	0.83	0.52	0.83	1.5	0.78	0.27	1.06	1.2	200	PVC	1.00	34.22	1.06
	SAN MH 12	EX SAN MH A	0.00	0.83	0.52	0.83	1.5	0.78	0.27	1.06	13.8	200	PVC	1.00	34.22	1.06
Legget-2 Legget-3	EX SAN MH A	EX SAN MH B	0.00	0.15	1.75	2.85	1.5	2.62	0.94	3.56	60.2	250	PVC	0.30	33.98	0.67
	EX SAN MH B	EX SAN MH C	0.00	0.17	1.75	3.02	1.5	2.62	1.00	3.62	68.0	250	PVC	0.29	33.41	0.66
Parking Garage Access Road + Workyard Access Road	NOKIA-4	SAN MH 7	0.00	0.95	0.00	2.15	1.5	0.00	0.71	0.71	3.9	200	PVC	2.00	54.10	1.67
0.00			1.20													
Retained Lands Access Road	RET LANDS	SAN MH 8	0.43	0.78	0.43	0.78	1.5	0.65	0.26	0.91	5.4	200	PVC	1.00	45.91	1.42
	Access Road	SAN MH 8	0.00	0.00	0.43	0.78	1.5	0.65	0.26	0.91	20.4	200	PVC	1.00	45.91	1.42
South Access Road	SAN MH 9	SAN MH 10	0.00	0.00	0.43	2.93	1.5	0.65	0.97	1.62	52.8	250	PVC	1.00	51.91	1.02
	SAN MH 10	SAN MH 11	0.00	0.00	0.43	2.93	1.5	0.65	0.97	1.62	27.8	250	PVC	0.35	36.70	0.72
	SAN MH 11	EX SAN MH C	0.00	0.00	0.43	2.93	1.5	0.65	0.97	1.62	16.1	250	PVC	0.35	36.70	0.72
Sanmina (500 March Road) Legget-4	EX SAN MH	EX SAN MH D	0.35	2.20	0.35	2.20	5.7	2.00	0.72	2.72	25.4	250	PVC	0.50	43.87	0.87
	EX SAN MH D	EX SAN MH C	0.00	0.17	0.35	2.37	5.7	2.00	0.78	2.78	55.1	250	PVC	0.33	35.64	0.70
Legget Drive	EX SAN MH C	EX SAN MH E	0.00	0.00	2.53	8.31	1.5	3.80	2.74	6.54	26.7	250	PVC	0.34	36.17	0.71
KRP Site	EX SAN MH E	EX SAN MH F	0.00	0.00	2.53	8.31	1.5	3.80	2.74	6.54	50.4	250	PVC	0.50	43.87	0.87
	EX SAN MH F	EX SAN MH G	0.00	0.00	2.53	8.31	1.5	3.80	2.74	6.54	44.0	250	PVC	0.50	43.87	0.87
	EX SAN MH G	EX SAN MH H	0.00	0.00	2.53	8.31	1.5	3.80	2.74	6.54	9.1	250	PVC	1.00	62.04	1.22
KRP Site (Tower C)	TOWER C	EX SAN MH H	0.65	1.24	0.65	1.24	3.5	2.29	0.41	2.70	114.3	250	PVC	0.40	39.24	0.77
KRP Site	EX SAN MH H	EX SAN MH I	0.00	0.00	3.18	9.55	1.5	4.77	3.15	7.93	9.5	250	PVC	1.00	62.04	1.22
	EX SAN MH I	EX SAN MH J	0.00	0.00	3.18	9.55	1.5	4.77	3.15	7.93	48.1	250	PVC	0.67	50.78	1.00
KRP Site (Tower D)	TOWER D	EX SAN MH J	0.96	3.37	0.96	3.37	1.5	1.44	1.11	2.55	34.0	200	PVC	1.30	39.01	1.20
KRP Site	EX SAN MH J	EX SAN MH K	0.00	0.00	4.14	12.92	1.5	6.22	4.26	10.48	61.9	250	PVC	0.35	36.70	0.72
KRP Site (Brookstreet Hotel)	HOTEL	EX SAN MH K	2.21	4.38	2.21	4.38	1.0 - 3.8	6.80	1.45	8.25	22.0	200	PVC	0.90	32.46	1.00
KRP Site	EX SAN MH K	EX SAN MH L	0.00	0.00	6.35	17.30	1.5	9.53	5.71	15.24	21.0	250	PVC	0.38	38.24	0.75
KRP Site (Parking Structure)	PARKING	FUTURE SAN MH 3	0.00	1.07	0.00	1.07	1.5	0.00	0.35	0.35	13.7	250	PVC	0.40	39.24	0.77
Proposed Brookstreet Apts.	FUTURE APTS.	FUTURE SANMH 1	1.80	0.39	1.80	0.39	1.0-3.4	5.39	0.13	5.52	6.1	250	PVC	2.00	87.74	1.73
KRP Site	FUTURE SANMH 1	FUTURE SANMH 2	0.00	0.00	1.80	0.39	1.0-3.4	5.39	0.13	5.52	24.0	250	PVC	0.50	43.87	0.87
	FUTURE SANMH 2	FUTURE SANMH 3	0.00	0.00	1.80	0.39	1.0-3.4	5.39	0.13	5.52	35.9	250	PVC	0.50	43.87	0.87
KRP Site	FUTURE SANMH 3	EX SAN MH L	0.00	0.00	1.80	1.46	1.0-3.4	5.39	0.48	5.87	77.4	250	PVC	0.40	39.24	0.77
KRP Site	EX SAN MH L	EX SAN MH M	0.00	0.00	8.15	18.76	1.5	12.23	6.19	18.42	88.9	250	PVC	0.38	38.24	0.75
KRP Site	EX SAN MH M	EX. 750 TRUNK	0.00	0.00	8.15	18.76	1.5	12.23	6.19	18.42	100.1	250	PVC	0.52	44.74	0.88

- Notes:
- $Q(d) = Q(p) + Q(i)$, where
 $Q(d)$ = Design Flow (L/sec)
 $Q(p)$ = Population Flow (L/sec)
 $Q(i)$ = Extraneous Flow (L/sec)
 - $Q(i) = 0.33 \text{ L/sec/ha}$
 - Daily Sanitary Flows from Residential Development = 280L/person/day (Section 4, Ottawa Sewer Design Guidelines)
 - Daily Sanitary Flows from Office Towers = 75 L/person/day (Appendix 4-A, Ottawa Sewer Design Guidelines)
 - Residential Peaking Factor: Harmon Equation (Maximum Peaking Factor = 3.8)
 - Commercial Peaking Factor = 1.5 (Figure 4.3 Ottawa Sewer Design Guidelines)
 - Sanmina (500 March Road) Peaking Factor = 5.7 (Appendix 4-B Ottawa Sewer Design Guidelines)
 - Refer to Sanitary Drainage Area Plan (C400) for details of drainage areas and sanitary manhole number designation.
 - Refer to the 'Sanitary and Storm Sewer Design Brief - Kanata Research Park Lands' for a breakdown of Daily Sewage Flow components and applicable peaking factors from the KRP lands.

- Sanitary sewer flows from Nokia and Retained Lands properties to Legget sanitary sewer.
- Extension of sanitary sewer in Legget Drive.
- Sanitary drainage area design based on future residential redevelopment.
- Sanitary sewer segment with least available excess capacity.

APPENDIX D

Water Demands, FUS Calculations, Watermain Boundary Conditions, Schematic of the Hydraulic Model and Modelling Results

570 & 520 March Road - Nokia Campus

Summary

WATER ANALYSIS

DOMESTIC WATER DEMANDS

Commercial, Office, Retail and Other Uses	Average Day Demand (L/s)	Maximum Day Demand (L/s)	Peak Hour Demand (L/s)
Office Tower	0.61	0.91	1.64
East Retail Building (Gym with Showers)	0.19	0.28	0.50
West Retail Building (Quick Food Service)	0.22	0.33	0.59
Social Café & Link (Quick Service Retail)	0.22	0.33	0.59
R&D Lab Building	0.52	0.78	1.41
Open Air Parking Garage	0.00	0.00	0.00
520 March (Future Development)	0.43	0.65	1.17
Total	2.18	3.27	5.89

570 March Road - Nokia Campus
8-Storey Office Tower
WATER ANALYSIS

DOMESTIC WATER DEMANDS

Office Use	Post-Development	
Office Tower	700	Staff
Average Day Demand (75 L/staff/day)	0.61	L/s
Maximum Day Demand (1.5 x avg. day)	0.91	L/s
Peak Hour Demand (1.8 x max. day)	1.64	L/s
Total Average Day Demand	0.61	L/s
Total Maximum Day Demand	0.91	L/s
Total Peak Hour Demand	1.64	L/s

570 March Road - Nokia Campus
1-Storey Retail East
WATER ANALYSIS

DOMESTIC WATER DEMANDS

Commercial Use	Post-Development	
East Retail Building (Gym with Showers)	200	Users (2x per day)
Average Day Demand (40 L/User/day)	0.19	L/s
Maximum Day Demand (1.5 x avg. day)	0.28	L/s
Peak Hour Demand (1.8 x max. day)	0.50	L/s
Total Average Day Demand	0.19	L/s
Total Maximum Day Demand	0.28	L/s
Total Peak Hour Demand	0.50	L/s

570 March Road - Nokia Campus
1-Storey Retail West
WATER ANALYSIS

DOMESTIC WATER DEMANDS

Commercial Use	Post-Development	
West Retail Building (Quick Food Service)	50	Seats (3x per day)
Average Day Demand (125 L/seat/day)	0.22	L/s
Maximum Day Demand (1.5 x avg. day)	0.33	L/s
Peak Hour Demand (1.8 x max. day)	0.59	L/s
Total Average Day Demand	0.22	L/s
Total Maximum Day Demand	0.33	L/s
Total Peak Hour Demand	0.59	L/s

570 March Road - Nokia Campus
2-Storey Social Café/Link
WATER ANALYSIS

DOMESTIC WATER DEMANDS

Commercial and Other Uses	Post-Development	
Social Café & Link (Quick Service Retail)	50	Seats (3x per day)
Average Day Demand (125 L/seat/day)	0.22	L/s
Maximum Day Demand (1.5 x avg. day)	0.33	L/s
Peak Hour Demand (1.8 x max. day)	0.59	L/s
Total Average Day Demand	0.22	L/s
Total Maximum Day Demand	0.33	L/s
Total Peak Hour Demand	0.59	L/s

570 March Road - Nokia Campus
5-Storey R&D Lab Building
WATER ANALYSIS

DOMESTIC WATER DEMANDS

Office and Other Uses	Post-Development	
R&D Lab Building	600	Employees
Average Day Demand (75 L/employee/day)	0.52	L/s
Maximum Day Demand (1.5 x avg. day)	0.78	L/s
Peak Hour Demand (1.8 x max. day)	1.41	L/s
Total Average Day Demand	0.52	L/s
Total Maximum Day Demand	0.78	L/s
Total Peak Hour Demand	1.41	L/s

570 March Road - Nokia Campus 3-Storey Open Air Parking Garage WATER ANALYSIS

DOMESTIC WATER DEMANDS

Parking Garage for Office and Commercial Uses	Post-Development	
Open Air Parking Garage	900	people
Average Day Demand (0 L/User/day)	0.00	L/s
Maximum Day Demand (1.5 x avg. day)	0.00	L/s
Peak Hour Demand (1.8 x max. day)	0.00	L/s
Total Average Day Demand	0.00	L/s
Total Maximum Day Demand	0.00	L/s
Total Peak Hour Demand	0.00	L/s

**520 March Road - Retained Lands
8-Storey Office Tower (Future Development)
WATER ANALYSIS**

DOMESTIC WATER DEMANDS

Office Use	Post-Development	
Office Tower (Future Development)	500	Staff
Average Day Demand (75 L/staff/day)	0.43	L/s
Maximum Day Demand (1.5 x avg. day)	0.65	L/s
Peak Hour Demand (1.8 x max. day)	1.17	L/s
Total Average Day Demand	0.43	L/s
Total Maximum Day Demand	0.65	L/s
Total Peak Hour Demand	1.17	L/s

FUS - Fire Flow Calculations



Engineers, Planners & Landscape Architects

Novatech Project #: 123043
 Project Name: 570 & 520 March Road
 Date: 8/19/2024
 Input By: K. D'sa
 Reviewed By: F. Thauvette

Legend: Input by User
 No Input Required

Reference: Fire Underwriter's Survey Guideline (2020)
 Formula Method

Building Description: 8-Storey Office Building and Social Café
 Type II - Non-combustible construction

Step		Choose		Value Used	Total Fire Flow (L/min)			
Base Fire Flow								
1	Construction Material	Coefficient related to type of construction C	Type V - Wood frame	1.5	0.8			
			Type IV - Mass Timber	Varies				
			Type III - Ordinary construction	1				
			Type II - Non-combustible construction	Yes 0.8				
			Type I - Fire resistive construction (2 hrs)	0.6				
2	Floor Area	A	Podium Level Footprint (m ²)	5348	8,022			
			Total Floors/Storeys (Podium)	3				
			Tower Footprint (m ²)	2910				
			Total Floors/Storeys (Tower)	5				
			Protected Openings (1 hr)	Yes				
			A, Total Effective Floor Area (m ²)					
	F	Base fire flow without reductions				16,000		
	$F = 220 C (A)^{0.5}$							
Reductions or Surcharges								
3	Occupancy hazard reduction or surcharge	(1)	FUS Table 3		Reduction/Surcharge	13,600		
			Non-combustible				-25%	
			Limited combustible	Yes			-15%	
			Combustible				0%	
			Free burning				15%	
Rapid burning		25%						
4	Sprinkler Reduction	(2)	FUS Table 4		Reduction	-6,800		
			Adequately Designed System (NFPA 13)	Yes			-30%	-30%
			Standard Water Supply	Yes			-10%	-10%
			Fully Supervised System	Yes			-10%	-10%
			Cumulative Sub-Total				-50%	
Area of Sprinklered Coverage (m²)	30594	100%						
Cumulative Total		-50%						
5	Exposure Surcharge per	(3)	FUS Table 5		Surcharge	0		
			North Side	2Hr Firewall			0%	
			East Side	2Hr Firewall			0%	
			South Side	2Hr Firewall			0%	
			West Side	>30m			0%	
Cumulative Total		0%						
Results								
6	(1) + (2) + (3)	Total Required Fire Flow, rounded to nearest 1000L/min		L/min	7,000			
		(2,000 L/min < Fire Flow < 45,000 L/min)		or	L/s	117		
				or	USGPM	1,849		

FUS - Fire Flow Calculations



Engineers, Planners & Landscape Architects

Novatech Project #: 123043
 Project Name: 570 & 520 March Road
 Date: 8/19/2024
 Input By: K. D'sa
 Reviewed By: François Thauvette

Legend: Input by User
 No Input Required

Reference: Fire Underwriter's Survey Guideline (2020)
 Formula Method

Building Description: 1-Storey Retail East Building
 Type II - Non-combustible construction

Step		Choose		Value Used	Total Fire Flow (L/min)
Base Fire Flow					
1	Construction Material		Multiplier		0.8
	Coefficient related to type of construction C	Type V - Wood frame		1.5	
		Type IV - Mass Timber		Varies	
		Type III - Ordinary construction		1	
		Type II - Non-combustible construction	Yes	0.8	
Type I - Fire resistive construction (2 hrs)			0.6		
2	Floor Area				5,000
	A	Building Footprint (m ²)	740		
		Number of Floors/Storeys	1		
		Protected Openings (1 hr) if C<1.0			
		Area of structure considered (m ²)		740	
F	Base fire flow without reductions				
		F = 220 C (A)^{0.5}			
Reductions or Surcharges					
3	Occupancy hazard reduction or surcharge		FUS Table 3	Reduction/Surcharge	5,000
	(1)	Non-combustible		-25%	
		Limited combustible		-15%	
		Combustible	Yes	0%	
		Free burning		15%	
Rapid burning			25%		
4	Sprinkler Reduction		FUS Table 4	Reduction	-2,500
	(2)	Adequately Designed System (NFPA 13)	Yes	-30%	
		Standard Water Supply	Yes	-10%	
		Fully Supervised System	Yes	-10%	
		Cumulative Sub-Total			
Area of Sprinklered Coverage (m²)		740	100%		
		Cumulative Total		-50%	
5	Exposure Surcharge		FUS Table 5	Surcharge	500
	(3)	North Side	20.1 - 30 m	10%	
		East Side	>30m	0%	
		South Side	2Hr Firewall	0%	
		West Side	2Hr Firewall	0%	
		Cumulative Total		10%	
Results					
6	(1) + (2) + (3)	Total Required Fire Flow, rounded to nearest 1000L/min		L/min	3,000
		(2,000 L/min < Fire Flow < 45,000 L/min)		or	50
				or	793

FUS - Fire Flow Calculations



Engineers, Planners & Landscape Architects

Novatech Project #: 123043
 Project Name: 570 & 520 March Road
 Date: 8/19/2024
 Input By: K. D'sa
 Reviewed By: François Thauvette

Legend: Input by User
 No Input Required

Reference: Fire Underwriter's Survey Guideline (2020)
 Formula Method

Building Description: 1-Storey Retail West Building
 Type II - Non-combustible construction

Step		Choose		Value Used	Total Fire Flow (L/min)	
Base Fire Flow						
1	Construction Material C Coefficient related to type of construction	Type V - Wood frame		1.5	0.8	
		Type IV - Mass Timber		Varies		
		Type III - Ordinary construction		1		
		Type II - Non-combustible construction	Yes	0.8		
		Type I - Fire resistive construction (2 hrs)		0.6		
2	Floor Area A Number of Floors/Storeys	Building Footprint (m ²)	1430		1,430	
		Number of Floors/Storeys	1			
		Protected Openings (1 hr) if C<1.0				
		Area of structure considered (m ²)				
	F Base fire flow without reductions				7,000	
Reductions or Surcharges						
3	(1) Occupancy hazard reduction or surcharge	FUS Table 3		Reduction/Surcharge	0%	
		Non-combustible		-25%		
		Limited combustible		-15%		
		Combustible	Yes	0%		
		Free burning		15%		
Rapid burning		25%				
4	(2) Sprinkler Reduction	FUS Table 4		Reduction	-3,500	
		Adequately Designed System (NFPA 13)	Yes	-30%		
		Standard Water Supply	Yes	-10%		
		Fully Supervised System	Yes	-10%		
		Cumulative Sub-Total		-50%		
Area of Sprinklered Coverage (m ²)	1,430	100%				
Cumulative Total		-50%				
5	(3) Exposure Surcharge	FUS Table 5		Surcharge	2,100	
		North Side	20.1 - 30 m	10%		
		East Side	3.1 - 10 m	20%		
		South Side	2Hr Firewall	0%		
		West Side	>30m	0%		
Cumulative Total		30%				
Results						
6	(1) + (2) + (3)	Total Required Fire Flow, rounded to nearest 1000L/min		L/min	6,000	
		(2,000 L/min < Fire Flow < 45,000 L/min)		or	L/s	100
				or	USGPM	1,585

FUS - Fire Flow Calculations



Engineers, Planners & Landscape Architects

Novatech Project #: 123043
 Project Name: 570 & 520 March Road
 Date: 8/19/2024
 Input By: K. D'sa
 Reviewed By: François Thauvette

Legend: Input by User
 No Input Required

Reference: Fire Underwriter's Survey Guideline (2020)
 Formula Method

Building Description: 5-Storey R&D Lab Building
 Type II - Non-combustible construction

Step		Choose		Value Used	Total Fire Flow (L/min)
Base Fire Flow					
1	Construction Material		Multiplier		0.8
	Coefficient related to type of construction C	Type V - Wood frame		1.5	
		Type IV - Mass Timber		Varies	
		Type III - Ordinary construction		1	
		Type II - Non-combustible construction	Yes	0.8	
Type I - Fire resistive construction (2 hrs)			0.6		
2	Floor Area				28,000
	A	Building Footprint (m ²)	7345		
		Number of Floors/Storeys	5		
		Protected Openings (1 hr) if C<1.0			
		Area of structure considered (m ²)		25,708	
F	Base fire flow without reductions				
	F = 220 C (A)^{0.5}				
Reductions or Surcharges					
3	Occupancy hazard reduction or surcharge		FUS Table 3	Reduction/Surcharge	28,000
	(1)	Non-combustible		-25%	
		Limited combustible		-15%	
		Combustible	Yes	0%	
		Free burning		15%	
Rapid burning			25%		
4	Sprinkler Reduction		FUS Table 4	Reduction	-14,000
	(2)	Adequately Designed System (NFPA 13)	Yes	-30%	
		Standard Water Supply	Yes	-10%	
		Fully Supervised System	Yes	-10%	
		Cumulative Sub-Total			
Area of Sprinklered Coverage (m²)	36,725	100%			
Cumulative Total			-50%		
5	Exposure Surcharge		FUS Table 5	Surcharge	0
	(3)	North Side	2Hr Firewall	0%	
		East Side	>30m	0%	
		South Side	>30m	0%	
		West Side	2Hr Firewall	0%	
Cumulative Total			0%		
Results					
6	(1) + (2) + (3)	Total Required Fire Flow, rounded to nearest 1000L/min		L/min	14,000
		(2,000 L/min < Fire Flow < 45,000 L/min)		or	233
				or	3,699

FUS - Fire Flow Calculations



Engineers, Planners & Landscape Architects

Novatech Project #: 123043
 Project Name: 570 & 520 March Road
 Date: 10/18/2024
 Input By: K. D'sa
 Reviewed By: François Thauvette

Legend: Input by User
 No Input Required

Reference: Fire Underwriter's Survey Guideline (2020)
 Formula Method

Building Description: 3-Storey Open Air Parking Garage
 Type II - Non-combustible construction

Step			Choose		Value Used	Total Fire Flow (L/min)
Base Fire Flow						
1	Construction Material			Multiplier		
	Coefficient related to type of construction C	Type V - Wood frame		1.5	0.8	
		Type IV - Mass Timber		Varies		
		Type III - Ordinary construction		1		
		Type II - Non-combustible construction	Yes	0.8		
Type I - Fire resistive construction (2 hrs)			0.6			
2	Floor Area					
	A	Building Footprint (m ²)	9450		9,450	
		Number of Floors/Storeys	1			
		Protected Openings (1 hr) if C<1.0				
		Area of structure considered (m ²)				
F	Base fire flow without reductions				17,000	
	F = 220 C (A)^{0.5}					
Reductions or Surcharges						
3	Occupancy hazard reduction or surcharge		FUS Table 3	Reduction/Surcharge		17,000
	(1)	Non-combustible		-25%	0%	
		Limited combustible		-15%		
		Combustible	Yes	0%		
		Free burning		15%		
Rapid burning			25%			
4	Sprinkler Reduction		FUS Table 4	Reduction		0
	(2)	Adequately Designed System (NFPA 13)		-30%		
		Standard Water Supply		-10%		
		Fully Supervised System		-10%		
		Cumulative Sub-Total		0%		
Area of Sprinklered Coverage (m²)			0%			
		Cumulative Total	0%			
5	Exposure Surcharge		FUS Table 6	Surcharge		1,360
	(3)	North Side	2Hr Firewall		0%	
		East Side	2Hr Firewall		0%	
		South Side	10.1 - 20 m		8%	
		West Side	>30m		0%	
		Cumulative Total	8%			
Results						
6	(1) + (2) + (3)	Total Required Fire Flow, rounded to nearest 1000L/min			L/min	18,000
		(2,000 L/min < Fire Flow < 45,000 L/min)		or	L/s	300
				or	USGPM	4,756

FUS - Fire Flow Calculations



Engineers, Planners & Landscape Architects

Novatech Project #: 123043
 Project Name: 570 & 520 March Road
 Date: 10/18/2024
 Input By: K. D'sa
 Reviewed By: François Thauvette

Legend: Input by User
 No Input Required

Reference: Fire Underwriter's Survey Guideline (2020)
 Formula Method

Building Description: Retained Lands: 8-Storey Office Building (Future Development)
 Type II - Non-combustible construction

Step		Choose		Value Used	Total Fire Flow (L/min)
Base Fire Flow					
1	Construction Material		Multiplier		0.8
	Coefficient related to type of construction C	Type V - Wood frame		1.5	
		Type IV - Mass Timber		Varies	
		Type III - Ordinary construction		1	
		Type II - Non-combustible construction	Yes	0.8	
Type I - Fire resistive construction (2 hrs)			0.6		
2	Floor Area				19,000
	A	Building Footprint (m ²)	2350		
		Number of Floors/Storeys	8		
		Protected Openings (1 hr) if C<1.0			
		Area of structure considered (m ²)		11,750	
F	Base fire flow without reductions				
	$F = 220 C (A)^{0.5}$				
Reductions or Surcharges					
3	Occupancy hazard reduction or surcharge		FUS Table 3	Reduction/Surcharge	16,150
	(1)	Non-combustible		-25%	
		Limited combustible	Yes	-15%	
		Combustible		0%	
		Free burning		15%	
Rapid burning			25%		
4	Sprinkler Reduction		FUS Table 4	Reduction	-6,460
	(2)	Adequately Designed System (NFPA 13)	Yes	-30%	
		Standard Water Supply	Yes	-10%	
		Fully Supervised System		-10%	
		Cumulative Sub-Total			
	Area of Sprinklered Coverage (m²)	18,800	100%		
	Cumulative Total		-40%		
5	Exposure Surcharge		FUS Table 6	Surcharge	1,292
	(3)	North Side	10.1 - 20 m	8%	
		East Side	>30m	0%	
		South Side	>30m	0%	
		West Side	>30m	0%	
	Cumulative Total		8%		
Results					
6	(1) + (2) + (3)	Total Required Fire Flow, rounded to nearest 1000L/min		L/min	11,000
		(2,000 L/min < Fire Flow < 45,000 L/min)		or	183
				or	2,906

FIRE HYDRANT SKETCH AND WATERMAIN INFRASTRUCTURE

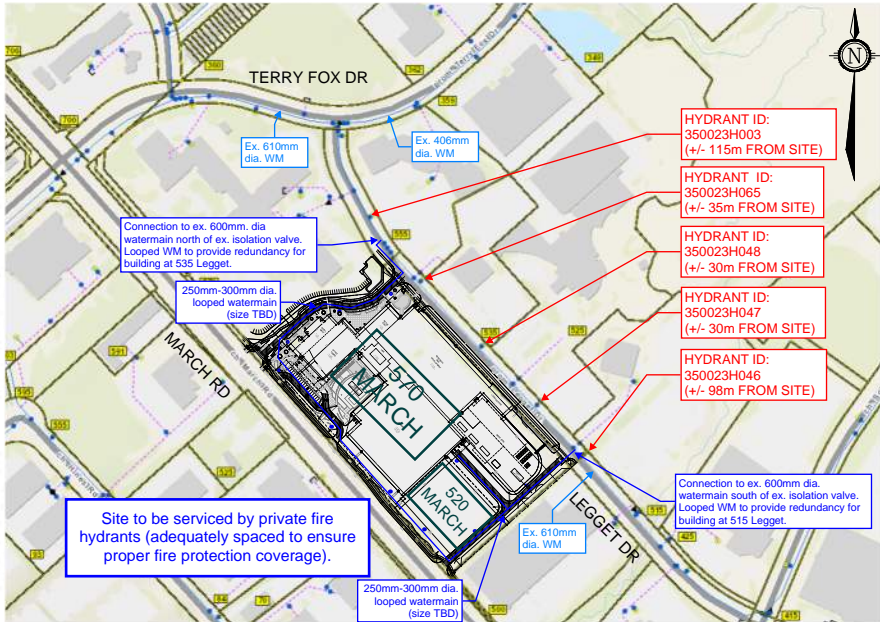

Kynan Dsa

From: Roy, Jean-Miguel <Jean-Miguel.Roy@ottawa.ca>
Sent: Monday, August 26, 2024 11:32 AM
To: Francois Thauvette
Cc: Kynan Dsa; Walker, Krishon; Brault, Ryan
Subject: RE: 570 and 520 March Road - Nokia - Request for Municipal WM boundary conditions (123043)

Hi Francois,

As discussed over the phone this morning, the City will not allow the new Nokia Innovation Campus located at 570 March Road to connect to the existing 600mm dia. backbone watermain located on Legget Drive. This watermain is a 610mm concrete pressure pipe (C-301) that is periodically isolated by the City for structural inspections. The City does not want to bring additional connections to the backbone watermain – directly or indirectly.

The City's position on this is that a local watermain will need to be built on Legget Drive by the developer(s) from Terry Fox Drive to Solandt Road in order to service this site. It is our understanding that this discussion has been initiated with the developer at 535 Legget Drive already. We can provide contact information from this development if needed.

Please let us know if you have any questions or concerns and we can schedule a meeting.

Best Regards,

Jean-Miguel Roy

Project Manager, Infrastructure Approvals
Planning, Real Estate and Economic Development Department
Services de la planification, Direction générale de la planification, de l'immobilier et du développement économique
110 Laurier Avenue West | 110 avenue Laurier Ouest
City of Ottawa | Ville d'Ottawa
613.580.2424 x 27566

From: Kynan Dsa <k.dsa@novatech-eng.com>
Sent: August 21, 2024 10:07 AM
To: Roy, Jean-Miguel <Jean-Miguel.Roy@ottawa.ca>
Cc: Francois Thauvette <f.thauvette@novatech-eng.com>
Subject: 570 and 520 March Road - Nokia - Request for Municipal WM boundary conditions (123043)

CAUTION: This email originated from an External Sender. Please do not click links or open attachments unless you recognize the source.

ATTENTION : Ce courriel provient d'un expéditeur externe. Ne cliquez sur aucun lien et n'ouvrez pas de pièce jointe, excepté si vous connaissez l'expéditeur.

Hi Jean-Miguel,

The purpose of this email is to request municipal watermain boundary conditions to complete a hydraulic network analysis to support the proposed development of the new Nokia Innovation Campus located at 570 March Road (southern portion of the recently severed larger Nokia property). The proposed service would provide water services to the Nokia campus (570 March Road), future

development on the severed parcel at 520 March Road , and redundancy for the buildings at 515 and 535 Legget Drive. Please refer to the attached sketch that identifies the existing water infrastructure along Legget Drive, as well as the proposed looped watermain network and hydrants. The sketch also identifies the two (2) proposed connection locations along Legget Drive. The northern segment of the waterloop proposes a standard connection to the existing 600mm dia. watermain north of the existing isolation valve. The southern segment of the waterloop proposes a standard connection to the existing 600mm dia. watermain south of the existing isolation valve. This watermain configuration will allow the proposed development to have a looped system that can adequately service the proposed development on the subject lands. The size of the private watermain and spacing of the on-site hydrants will be based on the fire flow requirements (calculated per FUS guidelines) and modeling results. The total anticipated water demands for the proposed development are as follows:

- Average Day Demand = 2.18 L/s
- Maximum Day Demand = 3.27 L/s
- Peak Hour Demand = 5.89 L/s
- Maximum Fire Flow Demand Range = 50-333 L/s

See attached calculation sheets for details.

Please review and let me know if you require any additional information.

Thanks,

Kynan D'sa, B.A.Sc. (Engineering) (He/Him)

NOVATECH

Engineers, Planners & Landscape Architects

240 Michael Cowpland Drive, Suite 200, Ottawa, ON, K2M 1P6

Tel: 613.254.9643 Ext. 276 | Cell: 705.821.2278

The information contained in this email message is confidential and is for exclusive use of the addressee.

This e-mail originates from the City of Ottawa e-mail system. Any distribution, use or copying of this e-mail or the information it contains by other than the intended recipient(s) is unauthorized. Thank you.

Le présent courriel a été expédié par le système de courriels de la Ville d'Ottawa. Toute distribution, utilisation ou reproduction du courriel ou des renseignements qui s'y trouvent par une personne autre que son destinataire prévu est interdite. Je vous remercie de votre collaboration.

150 King Street West
Suite 1400
Toronto ON, M5H 1J9
Canada

Tel +1 416.601.3890

Gensler

October 23, 2023

To:

Krishon Walker, MCIP, RPP, PMP
Planner II | Urbaniste II
Economic Development Services | Services de développement économique
Strategic Initiatives Department | Direction générale des initiatives stratégiques
City of Ottawa | Ville d'Ottawa
T. 613-580-2424 ext. | poste 24161

Please find this letter as a formal confirmation that the drawings pertaining to the Site Plan Control Application # PC2024-0383 for 570 March Road, Kanata Ottawa meet the required parameters resulting in a reduction in fire flow. The development, comprised of a R&D Engineering Hub on March Road and an R&D Lab on Legget Drive and retail spaces along a new pedestrian-friendly lifestyle street to the north is constructed to ensure:

- The development is fully sprinklered, fully supervised, and designed as per NFPA 13,
- All structural elements have a minimum 2-hour fire rating,
- The development will be comprised of noncombustible materials as per the Ontario Building Code,
- The construction coefficient will equal 0.8 for Type II Noncombustible Construction

Should you have any questions, please do not hesitate to contact me at any time.

Sincerely,



Danny Pressacco, OAA
Technical Director, Senior Associate, Architect

+1 (416) 601.3890 Main
+1 (416) 660.3423 Mobile

Gensler

150 King Street W
Suite 1400
Toronto, ON
M5H 1J9
Canada

APPENDIX E

IDF Curves, SWM Calculations, Storm Sewer Design Sheets

APPENDIX 5-A

OTTAWA INTENSITY DURATION FREQUENCY (IDF) CURVE

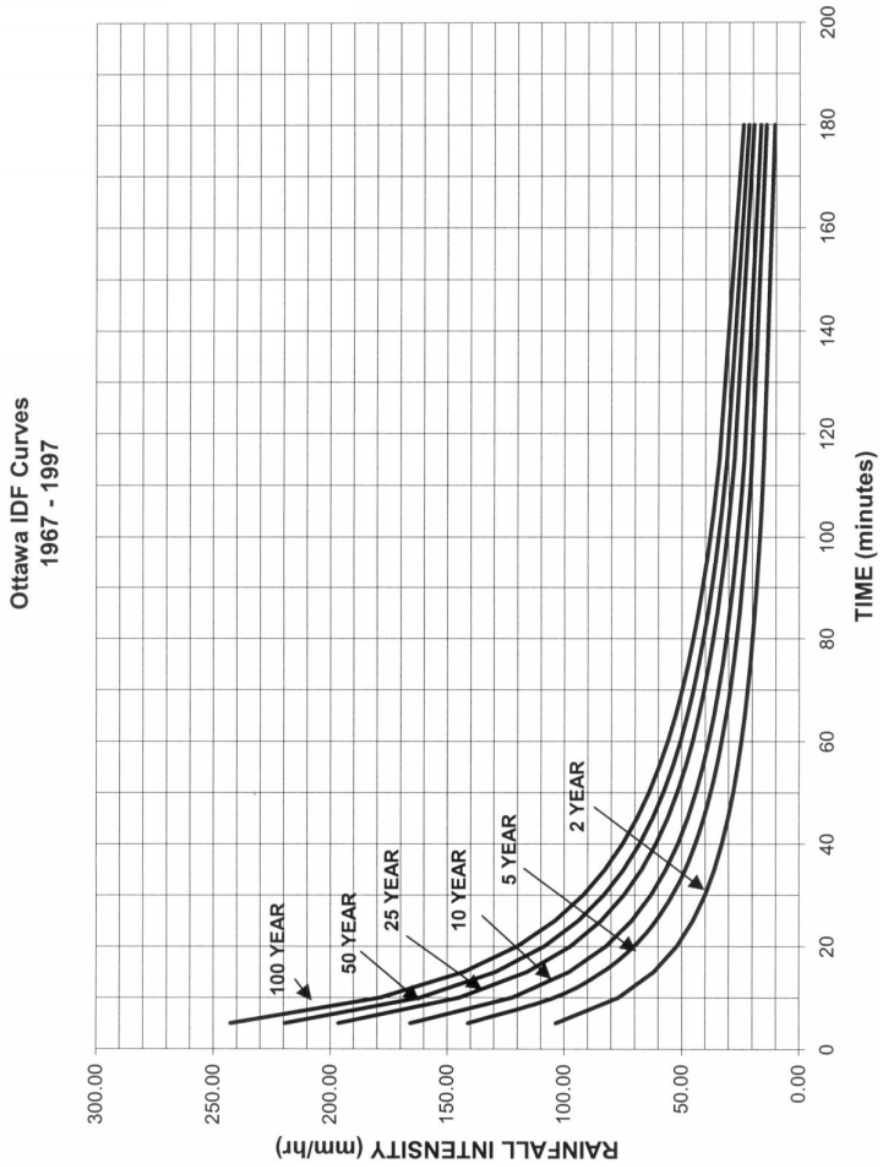

Proposed Nokia Ottawa Innovation Campus 570 and 520 March Road

Pre - Development Stormwater Flows		
Description	Area (ha)	Allowable Flows*
Allowable through ex. 375mm STM	1.772	63.8
Allowable through ex. 575mm STM	3.497	235.1

*allowables from KRP SWM report

Post - Development Stormwater Flows (Controlled to a maximum release rate of 63.8 L/s)																	
Area	Description	Area (ha)	A _{imp} (ha) C=0.9	A _{planter} (ha) C=0.6	A _{perv} (ha) C=0.2	C _s	C ₁₀₀	Uncontrolled Flow (L/s)			Controlled Flow (L/s)			Storage Required (m ³)			Storage Provided (m ³)
								2-year	5-year	100-year	2-year	5-year	100-year	2-year	5-year	100-year	
A-0a	Direct Runoff (Lifestyle Street)	0.039	0.000	0.000	0.039	0.20	0.25	1.7	2.3	5.0	-	-	-	-	-	-	-
A-0b	Direct Runoff (Legget Drive)	0.008	0.000	0.000	0.008	0.20	0.25	0.3	0.4	1.0	-	-	-	-	-	-	-
A-1	Controlled Flow - ICD (Lifestyle Street - Upper Side)	0.141	0.138	0.004	0.000	0.89	0.99	-	-	-	5.9	6.6	8.5	20.6	29.7	63.7	65.5
A-2	Controlled Flow - ICD (Lifestyle Street - Lower Side)	0.296	0.276	0.009	0.011	0.86	0.96	-	-	-	15.5	18.2	26.0	37.6	53.7	117.8	123.8
A-3	Retail West Roof	0.098	0.098	0.000	0.000	0.90	1.00	-	-	-	1.9	2.5	3.8	14.9	20.1	41.2	42.0
A-4	Retail East Roof	0.075	0.075	0.000	0.000	0.90	1.00	-	-	-	1.9	2.5	3.8	10.2	13.9	28.7	29.9
A-5	Office Tower Roof	0.288	0.288	0.000	0.000	0.90	1.00	-	-	-	9.0	9.7	11.1	35.8	53.0	120.6	130.0
A-6	Common Area and Amenity Roof	0.117	0.117	0.000	0.000	0.90	1.00	-	-	-	3.7	4.0	4.5	13.2	19.6	45.1	55.7
Totals :		1.061	-	-	-	-	-	2.0	2.8	5.9	37.9	43.5	57.6	132.4	190.0	417.1	-

Total On-Site Stormwater Flows	39.9	46.2	63.5
---------------------------------------	-------------	-------------	-------------

T_c = 10mins

Post - Development Stormwater Flows (Controlled to a maximum release rate of 235.1 L/s)																	
Area	Description	Area (ha)	A _{imp} (ha) C=0.9	A _{planter} (ha) C=0.6	A _{perv} (ha) C=0.2	C _s	C ₁₀₀	Uncontrolled Flow (L/s)			Controlled Flow (L/s)			Storage Required (m ³)			Storage Provided (m ³)
								2-year	5-year	100-year	2-year	5-year	100-year	2-year	5-year	100-year	
B-0a	Direct Runoff (Legget Drive)	0.038	0.003	0.000	0.036	0.25	0.30	2.0	2.7	5.7	-	-	-	-	-	-	-
B-0b	Direct Runoff (Access Route)	0.071	0.000	0.000	0.071	0.20	0.25	3.7	5.1	10.6	-	-	-	-	-	-	-
B-1	Controlled Flow - SWM Tank & ICD (R&D Lab)	0.795	0.795	0.000	0.000	0.90	1.00	-	-	-	21.9	27.2	41.0	137.1	188.4	380.0	406.7
B-2	Controlled Flow - ICD (Plaza & Entrance Dropoff)	0.584	0.367	0.024	0.193	0.66	0.74	-	-	-	31.9	35.8	48.0	48.3	71.2	159.1	164.1
B-3	Controlled Flow - ICD (Parking Structure)	1.187	1.162	0.000	0.025	0.89	0.98	-	-	-	23.7	29.8	46.0	222.2	303.3	603.6	608.1
B-4	Controlled Flow - ICD (Access Route)	0.752	0.726	0.000	0.025	0.88	0.97	-	-	-	23.9	28.8	43.0	118.9	165.5	336.3	341.8
C-0	Direct Runoff (Retained Lands)	0.064	0.000	0.000	0.064	0.20	0.25	2.7	3.7	9.5	-	-	-	-	-	-	-
C-1	Controlled Flow - ICD (Retained Lands)	0.642	0.000	0.000	0.642	0.20	0.25	-	-	-	26.1	26.5	27.0	8.6	15.0	49.6	65.5
C-2	Controlled Flow - ICD (Retained Lands - ROW)	0.075	0.075	0.000	0.000	0.90	1.00	-	-	-	1.6	2.0	3.0	14.0	19.1	38.4	41.6
Totals :		4.208	-	-	-	-	-	8.5	11.5	25.7	129.1	150.1	208.0	549.1	762.6	1566.9	-

Total On-Site Stormwater Flows	137.6	161.5	233.7
---------------------------------------	--------------	--------------	--------------

T_c = 10mins

Proposed Nokia Ottawa Innovation Campus Novatech Project No. 123043 Uncontrolled Runoff - 1:2 YEAR EVENT AREA A-0a Un-Controlled Runoff - 600 March Road				
OTTAWA IDF CURVE				
Area = 0.039 ha		Qallow = 1.7 L/s		
C = 0.20		Vol(max) = 0.0 m3		
Time (min)	Intensity (mm/hr)	Q (L/s)	Qnet (L/s)	Vol (m3)
5	103.57	2.31	0.60	0.18
10	76.81	1.71	0.00	0.00
15	61.77	1.38	-0.33	-0.30
20	52.03	1.16	-0.55	-0.66
25	45.17	1.01	-0.70	-1.06
30	40.04	0.89	-0.82	-1.47
35	36.06	0.80	-0.91	-1.91
40	32.86	0.73	-0.98	-2.35
45	30.24	0.67	-1.04	-2.80
50	28.04	0.62	-1.09	-3.26
55	26.17	0.58	-1.13	-3.72
60	24.56	0.55	-1.16	-4.19
65	23.15	0.52	-1.19	-4.66
70	21.91	0.49	-1.22	-5.13
75	20.81	0.46	-1.25	-5.61
90	18.14	0.40	-1.31	-7.05
105	16.13	0.36	-1.35	-8.51
120	14.56	0.32	-1.39	-9.98
135	13.30	0.30	-1.41	-11.45
150	12.25	0.27	-1.44	-12.94

Proposed Nokia Ottawa Innovation Campus Novatech Project No. 123043 Uncontrolled Runoff - 1:5 YEAR EVENT AREA A-0a Un-Controlled Runoff - 600 March Road				
OTTAWA IDF CURVE				
Area = 0.039 ha		Qallow = 2.3 L/s		
C = 0.20		Vol(max) = 0.0 m3		
Time (min)	Intensity (mm/hr)	Q (L/s)	Qnet (L/s)	Vol (m3)
5	141.18	3.14	0.82	0.25
10	104.19	2.32	0.00	0.00
15	83.56	1.86	-0.46	-0.41
20	70.25	1.56	-0.76	-0.91
25	60.90	1.36	-0.96	-1.45
30	53.93	1.20	-1.12	-2.01
35	48.52	1.08	-1.24	-2.60
40	44.18	0.98	-1.34	-3.21
45	40.63	0.90	-1.42	-3.82
50	37.65	0.84	-1.48	-4.44
55	35.12	0.78	-1.54	-5.07
60	32.94	0.73	-1.59	-5.71
65	31.04	0.69	-1.63	-6.35
70	29.37	0.65	-1.67	-7.00
75	27.89	0.62	-1.70	-7.65
90	24.29	0.54	-1.78	-9.61
105	21.58	0.48	-1.84	-11.59
120	19.47	0.43	-1.89	-13.58
135	17.76	0.40	-1.92	-15.59
150	16.36	0.36	-1.96	-17.60

Proposed Nokia Ottawa Innovation Campus Novatech Project No. 123043 Uncontrolled Runoff - 1:100 YEAR EVENT AREA A-0a Un-Controlled Runoff - 600 March Road				
OTTAWA IDF CURVE				
Area = 0.039 ha		Qallow = 5.0 L/s		
C = 0.25		Vol(max) = 0.0 m3		
Time (min)	Intensity (mm/hr)	Q (L/s)	Qnet (L/s)	Vol (m3)
5	242.70	6.74	1.78	0.53
10	178.56	4.96	0.00	0.00
15	142.89	3.97	-0.99	-0.89
20	119.95	3.33	-1.63	-1.95
25	103.85	2.88	-2.07	-3.11
30	91.87	2.55	-2.41	-4.33
35	82.58	2.29	-2.66	-5.59
40	75.15	2.09	-2.87	-6.89
45	69.05	1.92	-3.04	-8.21
50	63.95	1.77	-3.18	-9.54
55	59.62	1.65	-3.30	-10.89
60	55.89	1.55	-3.40	-12.25
65	52.65	1.46	-3.49	-13.63
70	49.79	1.38	-3.57	-15.01
75	47.26	1.31	-3.64	-16.40
90	41.11	1.14	-3.81	-20.60
105	36.50	1.01	-3.94	-24.84
120	32.89	0.91	-4.04	-29.10
135	30.00	0.83	-4.12	-33.39
150	27.61	0.77	-4.19	-37.70

Proposed Nokia Ottawa Innovation Campus Novatech Project No. 123043 Uncontrolled Runoff - 1:100 YR + 20% IDF Increase AREA A-0a Un-Controlled Runoff - 600 March Road				
OTTAWA IDF CURVE				
Area = 0.039 ha		Qallow = 5.9 L/s		
C = 0.25		Vol(max) = 0.0 m3		
Time (min)	Intensity (mm/hr)	Q (L/s)	Qnet (L/s)	Vol (m3)
5	291.24	8.08	2.14	0.64
10	214.27	5.95	0.00	0.00
15	171.47	4.76	-1.19	-1.07
20	143.94	3.99	-1.95	-2.34
25	124.62	3.46	-2.49	-3.73
30	110.24	3.06	-2.89	-5.20
35	99.09	2.75	-3.20	-6.71
40	90.17	2.50	-3.44	-8.26
45	82.86	2.30	-3.65	-9.85
50	76.74	2.13	-3.82	-11.45
55	71.55	1.99	-3.96	-13.07
60	67.07	1.86	-4.08	-14.71
65	63.18	1.75	-4.19	-16.35
70	59.75	1.66	-4.29	-18.01
75	56.71	1.57	-4.37	-19.68
90	49.33	1.37	-4.58	-24.72
105	43.80	1.22	-4.73	-29.80
120	39.47	1.10	-4.85	-34.92
135	36.00	1.00	-4.95	-40.07
150	33.13	0.92	-5.03	-45.24

Proposed Nokia Ottawa Innovation Campus
Novatech Project No. 123043
Uncontrolled Runoff - 1:2 YEAR EVENT
AREA A-0b Un-Controlled Runoff - Legget Drive

OTTAWA IDF CURVE
 Area = 0.008 ha Qallow = 0.3 L/s
 C = 0.20 Vol(max) = 0.0 m3

Time (min)	Intensity (mm/hr)	Q (L/s)	Qnet (L/s)	Vol (m3)
5	103.57	0.44	0.11	0.03
10	76.81	0.33	0.00	0.00
15	61.77	0.26	-0.06	-0.06
20	52.03	0.22	-0.11	-0.13
25	45.17	0.19	-0.14	-0.20
30	40.04	0.17	-0.16	-0.28
35	36.06	0.15	-0.17	-0.37
40	32.86	0.14	-0.19	-0.45
45	30.24	0.13	-0.20	-0.54
50	28.04	0.12	-0.21	-0.63
55	26.17	0.11	-0.22	-0.72
60	24.56	0.11	-0.22	-0.81
65	23.15	0.10	-0.23	-0.90
70	21.91	0.09	-0.24	-0.99
75	20.81	0.09	-0.24	-1.08
90	18.14	0.08	-0.25	-1.36
105	16.13	0.07	-0.26	-1.64
120	14.56	0.06	-0.27	-1.92
135	13.30	0.06	-0.27	-2.20
150	12.25	0.05	-0.28	-2.49

Proposed Nokia Ottawa Innovation Campus
Novatech Project No. 123043
Uncontrolled Runoff - 1:5 YEAR EVENT
AREA A-0b Un-Controlled Runoff - Legget Drive

OTTAWA IDF CURVE
 Area = 0.008 ha Qallow = 0.4 L/s
 C = 0.20 Vol(max) = 0.0 m3

Time (min)	Intensity (mm/hr)	Q (L/s)	Qnet (L/s)	Vol (m3)
5	141.18	0.60	0.16	0.05
10	104.19	0.45	0.00	0.00
15	83.56	0.36	-0.09	-0.08
20	70.25	0.30	-0.15	-0.17
25	60.90	0.26	-0.19	-0.28
30	53.93	0.23	-0.22	-0.39
35	48.52	0.21	-0.24	-0.50
40	44.18	0.19	-0.26	-0.62
45	40.63	0.17	-0.27	-0.73
50	37.65	0.16	-0.28	-0.85
55	35.12	0.15	-0.30	-0.98
60	32.94	0.14	-0.31	-1.10
65	31.04	0.13	-0.31	-1.22
70	29.37	0.13	-0.32	-1.35
75	27.89	0.12	-0.33	-1.47
90	24.29	0.10	-0.34	-1.85
105	21.58	0.09	-0.35	-2.23
120	19.47	0.08	-0.36	-2.61
135	17.76	0.08	-0.37	-3.00
150	16.36	0.07	-0.38	-3.38

Proposed Nokia Ottawa Innovation Campus
Novatech Project No. 123043
Uncontrolled Runoff - 1:100 YEAR EVENT
AREA A-0b Un-Controlled Runoff - Legget Drive

OTTAWA IDF CURVE
 Area = 0.008 ha Qallow = 1.0 L/s
 C = 0.25 Vol(max) = 0.0 m3

Time (min)	Intensity (mm/hr)	Q (L/s)	Qnet (L/s)	Vol (m3)
5	242.70	1.32	0.35	0.10
10	178.56	0.97	0.00	0.00
15	142.89	0.78	-0.19	-0.17
20	119.95	0.65	-0.32	-0.38
25	103.85	0.57	-0.41	-0.61
30	91.87	0.50	-0.47	-0.85
35	82.58	0.45	-0.52	-1.10
40	75.15	0.41	-0.56	-1.35
45	69.05	0.38	-0.60	-1.61
50	63.95	0.35	-0.62	-1.87
55	59.62	0.32	-0.65	-2.14
60	55.89	0.30	-0.67	-2.41
65	52.65	0.29	-0.69	-2.67
70	49.79	0.27	-0.70	-2.95
75	47.26	0.26	-0.72	-3.22
90	41.11	0.22	-0.75	-4.04
105	36.50	0.20	-0.77	-4.87
120	32.89	0.18	-0.79	-5.71
135	30.00	0.16	-0.81	-6.55
150	27.61	0.15	-0.82	-7.40

Proposed Nokia Ottawa Innovation Campus
Novatech Project No. 123043
Uncontrolled Runoff - 1:100 YR + 20% IDF Increase
AREA A-0b Un-Controlled Runoff - Legget Drive

OTTAWA IDF CURVE
 Area = 0.008 ha Qallow = 1.2 L/s
 C = 0.25 Vol(max) = 0.0 m3

Time (min)	Intensity (mm/hr)	Q (L/s)	Qnet (L/s)	Vol (m3)
5	291.24	1.59	0.42	0.13
10	214.27	1.17	0.00	0.00
15	171.47	0.93	-0.23	-0.21
20	143.94	0.78	-0.38	-0.46
25	124.62	0.68	-0.49	-0.73
30	110.24	0.60	-0.57	-1.02
35	99.09	0.54	-0.63	-1.32
40	90.17	0.49	-0.68	-1.62
45	82.86	0.45	-0.72	-1.93
50	76.74	0.42	-0.75	-2.25
55	71.55	0.39	-0.78	-2.57
60	67.07	0.37	-0.80	-2.89
65	63.18	0.34	-0.82	-3.21
70	59.75	0.33	-0.84	-3.53
75	56.71	0.31	-0.86	-3.86
90	49.33	0.27	-0.90	-4.85
105	43.80	0.24	-0.93	-5.85
120	39.47	0.21	-0.95	-6.85
135	36.00	0.20	-0.97	-7.86
150	33.13	0.18	-0.99	-8.88

Proposed Nokia Development Storage Calculations Using Average
Novatech Project No. 123043 Release Rate Equal to 50% of the Qpeak
REQUIRED STORAGE - 1:2 YEAR EVENT

AREA A-1 Controlled Site Flows (Lifestyle Street - Upper Side)

OTTAWA IDF CURVE Qpeak = 5.9 L/s
 Area = 0.141 ha Qavg = 3.0 L/s
 C = 0.89 Vol(max) = 20.6 m3
 (Vol calculated for Qallow-avg)

Time (min)	Tributary Ar (mm/hr)	Q (L/s)	Qnet (L/s)	Vol (m3)
5	103.57	36.26	33.31	9.99
10	76.81	26.89	23.94	14.36
15	61.77	21.62	18.67	16.81
20	52.03	18.22	15.27	18.32
25	45.17	15.81	12.86	19.29
30	40.04	14.02	11.07	19.92
35	36.06	12.62	9.67	20.32
40	32.86	11.51	8.56	20.53
45	30.24	10.59	7.64	20.62
50	28.04	9.82	6.87	20.60
55	26.17	9.16	6.21	20.50
60	24.56	8.60	5.65	20.33
65	23.15	8.11	5.16	20.11
70	21.91	7.67	4.72	19.83
75	20.81	7.29	4.34	19.52
90	18.14	6.35	3.40	18.37
105	16.13	5.65	2.70	17.00
120	14.56	5.10	2.15	15.47
135	13.30	4.65	1.70	13.81
150	12.25	4.29	1.34	12.05

Proposed Nokia Development Storage Calculations Using Average
Novatech Project No. 123043 Release Rate Equal to 50% of the Qpeak
REQUIRED STORAGE - 1:5 YEAR EVENT

AREA A-1 Controlled Site Flows (Lifestyle Street - Upper Side)

OTTAWA IDF CURVE Qpeak = 6.6 L/s
 Area = 0.141 ha Qavg = 3.3 L/s
 C = 0.89 Vol(max) = 29.7 m3
 (Vol calculated for Qallow-avg)

Time (min)	Intensity (mm/hr)	Q (L/s)	Qnet (L/s)	Vol (m3)
5	141.18	49.43	46.13	13.84
10	104.19	36.48	33.18	19.91
15	83.56	29.25	25.95	23.36
20	70.25	24.60	21.30	25.55
25	60.90	21.32	18.02	27.03
30	53.93	18.88	15.58	28.04
35	48.52	16.99	13.69	28.74
40	44.18	15.47	12.17	29.21
45	40.63	14.22	10.92	29.50
50	37.65	13.18	9.88	29.65
55	35.12	12.30	9.00	29.69
60	32.94	11.53	8.23	29.64
65	31.04	10.87	7.57	29.52
70	29.37	10.28	6.98	29.33
75	27.89	9.76	6.46	29.09
90	24.29	8.50	5.20	28.10
105	21.58	7.56	4.26	26.81
120	19.47	6.82	3.52	25.31
135	17.76	6.22	2.92	23.65
150	16.36	5.73	2.43	21.86

Proposed Nokia Development Storage Calculations Using Average
Novatech Project No. 123043 Release Rate Equal to 50% of the Qpeak
REQUIRED STORAGE - 1:100 YEAR EVENT

AREA A-1 Controlled Site Flows (Lifestyle Street - Upper Side)

OTTAWA IDF CURVE Qpeak = 8.5 L/s
 Area = 0.141 ha Qavg = 4.3 L/s
 C = 0.99 Vol(max) = 63.7 m3
 (Vol calculated for Qallow-avg)

Time (min)	Intensity (mm/hr)	Q (L/s)	Qnet (L/s)	Vol (m3)
5	242.70	94.49	90.24	27.07
10	178.56	69.52	65.27	39.16
15	142.89	55.63	51.38	46.25
20	119.95	46.70	42.45	50.94
25	103.85	40.43	36.18	54.27
30	91.87	35.77	31.52	56.73
35	82.58	32.15	27.90	58.59
40	75.15	29.26	25.01	60.02
45	69.05	26.88	22.63	61.11
50	63.95	24.90	20.65	61.95
55	59.62	23.21	18.96	62.58
60	55.89	21.76	17.51	63.04
65	52.65	20.50	16.25	63.36
70	49.79	19.38	15.13	63.57
75	47.26	18.40	14.15	63.67
90	41.11	16.01	11.76	63.48
105	36.50	14.21	9.96	62.75
120	32.89	12.81	8.56	61.61
135	30.00	11.68	7.43	60.17
150	27.61	10.75	6.50	58.50

Proposed Nokia Development Storage Calculations Using Average
Novatech Project No. 123043 Release Rate Equal to 50% of the Qpeak
REQUIRED STORAGE - 1:100 YR + 20% IDF Increase

AREA A-1 Controlled Site Flows (Lifestyle Street - Upper Side)

OTTAWA IDF CURVE Qpeak = 8.5 L/s
 Area = 0.141 ha Qavg = 4.3 L/s
 C = 0.99 Vol(max) = 80.8 m3
 (Vol calculated for Qallow-avg)

Time (min)	Intensity (mm/hr)	Q (L/s)	Qnet (L/s)	Vol (m3)
5	291.24	113.39	109.14	32.74
10	214.27	83.42	79.17	47.50
15	171.47	66.76	62.51	56.26
20	143.94	56.04	51.79	62.15
25	124.62	48.52	44.27	66.40
30	110.24	42.92	38.67	69.61
35	99.09	38.58	34.33	72.09
40	90.17	35.11	30.86	74.06
45	82.86	32.26	28.01	75.63
50	76.74	29.88	25.63	76.89
55	71.55	27.86	23.61	77.90
60	67.07	26.11	21.86	78.71
65	63.18	24.60	20.35	79.35
70	59.75	23.26	19.01	79.85
75	56.71	22.08	17.83	80.23
90	49.33	19.21	14.96	80.77
105	43.80	17.05	12.80	80.65
120	39.47	15.37	11.12	80.05
135	36.00	14.01	9.76	79.09
150	33.13	12.90	8.65	77.85

Structures	Size (mm)	Area (m ²)	T/G	Inv IN	Inv OUT
UG STORAGE	1144	49.52	82.51		80.17
STMMH 101	1200	1.13	82.24	80.14	80.12
STMMH 102	1200	1.13	82.05	79.54	79.49

PI = 3.141592654
 PIPE I.D. = 304.8 PVC
U/G Storage Pipe Volume
 End Area 0.073 (m²)
 Total Length 61.2 (m)
 Pipe Volume 4.5 (m³)

Area A-1: Storage Table					Underground Storage	Surface Storage						Total Storage		
Elevation (m)	System Depth (m)	UG STORAGE Volume (m ³)	STMMH 101 Volume (m ³)	STMMH 102 Volume (m ³)	Combined Volume (m ³)	UG STORAGE		STMMH 101		STMMH 102		Ponding Volume (m ³)	Total Volume (m ³)	Design Head
						Area (m ²)	Volume (m ³)	Area (m ²)	Volume (m ³)	Area (m ²)	Volume (m ³)			
79.49	0.00	0.00	0.00	0.00	4.46	-	-	-	-	-	-	-	0	-
80.47	0.30	14.86	0.40	1.11	20.83	-	-	-	-	-	-	-	20.8	0.83
80.65	0.48	23.77	0.60	1.31	30.15	-	-	-	-	-	-	-	30.1	1.01
81.30	1.13	55.96	1.33	2.05	63.81	-	-	-	-	-	-	-	63.8	1.66
81.31	1.14	55.96	1.35	2.06	63.83	-	-	-	-	-	-	-	63.8	1.67
82.05	1.88	55.96	2.18	2.90	65.50	0.0	0.0	0.0	0.0	0.0	0.0	0.0	65.5	2.41
82.10						0.00	0.00	0.00	0.00	0.00	0.00	0.0	65.5	2.46
82.15						0.00	0.00	0.00	0.00	0.00	0.00	0.0	65.5	2.51
82.20						0.00	0.00	0.00	0.00	0.00	0.00	0.0	65.5	2.56

Tempest Vortex LMF Model 100 ICD	
1:100 Yr	
Flow (L/s) = 8.5	Head (m) = 1.66
Elevation (m) = 81.30	Outlet Pipe Dia.(mm) = 304
Volume (m3) = 63.7	
1:5 Yr	
Flow (L/s) = 6.6	Head (m) = 1.01
Elevation (m) = 80.65	Outlet Pipe Dia.(mm) = 304
Volume (m3) = 29.7	
1:2 Yr	
Flow (L/s) = 5.9	Head (m) = 0.83
Elevation (m) = 80.47	Outlet Pipe Dia.(mm) = 304
Volume (m3) = 20.6	

Orifice Size - 1:100 yr Flow Check		
$Q=0.62 \times A \times (2gh)^{0.5}$		
	1:100 yr	Flow Check
Q (m ³ /s) =	0.0085	0.0084
g (m/s ²) =	9.81	9.81
h (m) =	1.66	1.66
A (m ²) =	0.002403729	0.00238
D (m) =	0.05532199	0.05500
D (mm) =	55	55.0

1:5 yr Flow Check	
	1:5 yr
Q (m ³ /s) =	0.0066
g (m/s ²) =	9.81
h (m) =	1.01
A (m ²) =	0.00238
D (m) =	0.055
D (mm) =	55

1:2 yr Flow Check	
	1:2 yr
Q (m ³ /s) =	0.0059
g (m/s ²) =	9.81
h (m) =	0.83
A (m ²) =	0.00238
D (m) =	0.055
D (mm) =	55

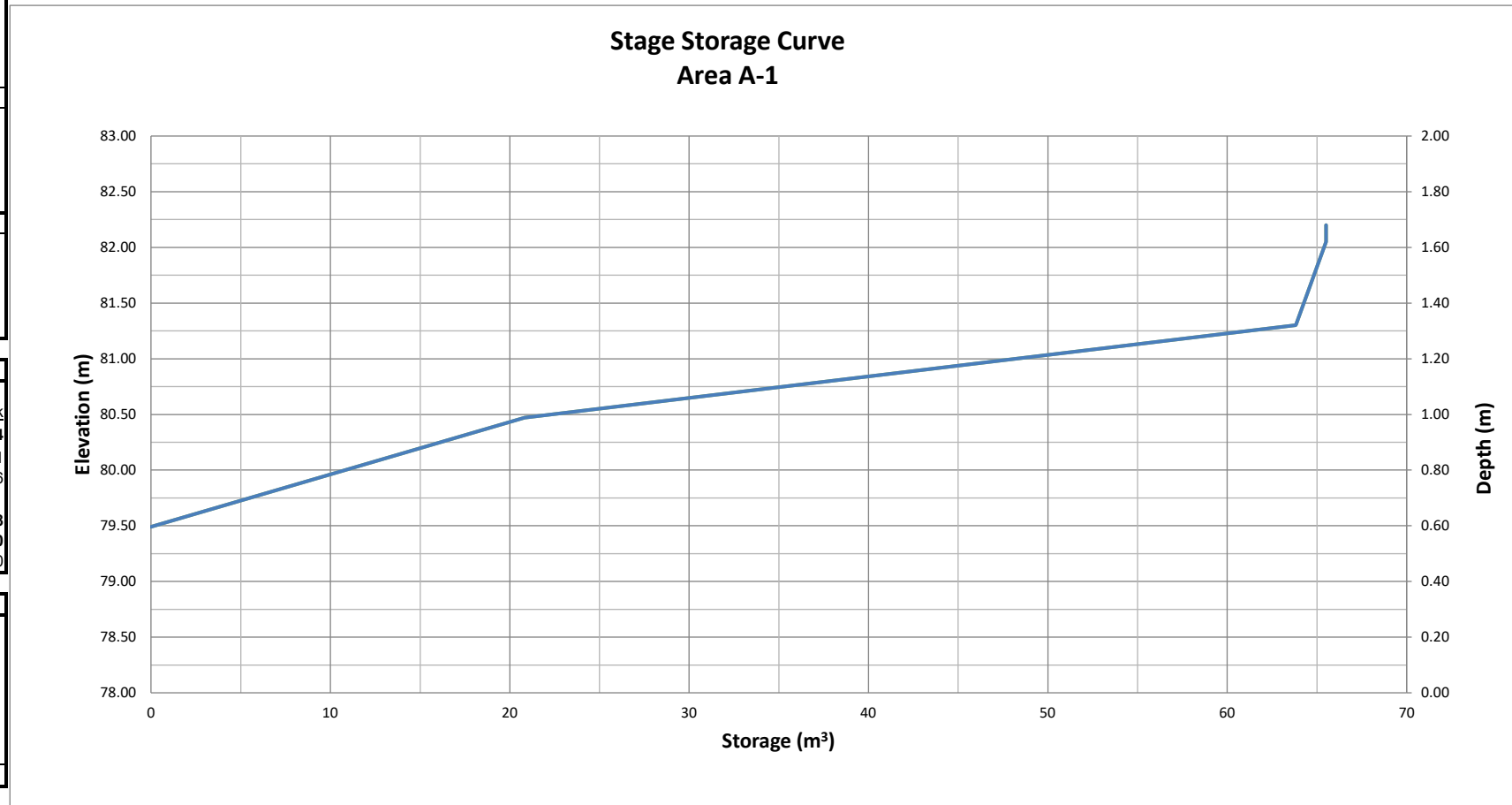

Proposed Nokia Development Storage Calculations Using Average
Novatech Project No. 123043 Release Rate Equal to 50% of the Qpeak
REQUIRED STORAGE - 1:2 YEAR EVENT

AREA A-2 Controlled Site Flows (Lifestyle Street - Lower Side)

OTTAWA IDF CURVE Qpeak = 15.5 L/s
 Area = 0.296 ha Qavg = 7.8 L/s
 C = 0.86 Vol(max) = 37.6 m3
 (Vol calculated for Qallow-avg)

Time (min)	Tributary Ar (mm/hr)	Q (L/s)	Qnet (L/s)	Vol (m3)
5	103.57	73.73	65.98	19.79
10	76.81	54.68	46.93	28.16
15	61.77	43.97	36.22	32.60
20	52.03	37.04	29.29	35.15
25	45.17	32.15	24.40	36.61
30	40.04	28.51	20.76	37.36
35	36.06	25.67	17.92	37.63
40	32.86	23.40	15.65	37.55
45	30.24	21.53	13.78	37.20
50	28.04	19.96	12.21	36.64
55	26.17	18.63	10.88	35.91
60	24.56	17.48	9.73	35.04
65	23.15	16.48	8.73	34.05
70	21.91	15.60	7.85	32.97
75	20.81	14.82	7.07	31.80
90	18.14	12.92	5.17	27.89
105	16.13	11.49	3.74	23.53
120	14.56	10.37	2.62	18.84
135	13.30	9.46	1.71	13.89
150	12.25	8.72	0.97	8.75

Proposed Nokia Development Storage Calculations Using Average
Novatech Project No. 123043 Release Rate Equal to 50% of the Qpeak
REQUIRED STORAGE - 1:5 YEAR EVENT

AREA A-2 Controlled Site Flows (Lifestyle Street - Lower Side)

OTTAWA IDF CURVE Qpeak = 18.2 L/s
 Area = 0.296 ha Qavg = 9.1 L/s
 C = 0.86 Vol(max) = 53.7 m3
 (Vol calculated for Qallow-avg)

Time (min)	Intensity (mm/hr)	Q (L/s)	Qnet (L/s)	Vol (m3)
5	141.18	100.50	91.40	27.42
10	104.19	74.17	65.07	39.04
15	83.56	59.48	50.38	45.34
20	70.25	50.01	40.91	49.09
25	60.90	43.35	34.25	51.38
30	53.93	38.39	29.29	52.72
35	48.52	34.54	25.44	53.42
40	44.18	31.45	22.35	53.65
45	40.63	28.92	19.82	53.52
50	37.65	26.80	17.70	53.11
55	35.12	25.00	15.90	52.48
60	32.94	23.45	14.35	51.67
65	31.04	22.10	13.00	50.70
70	29.37	20.91	11.81	49.60
75	27.89	19.85	10.75	48.39
90	24.29	17.29	8.19	44.23
105	21.58	15.36	6.26	39.46
120	19.47	13.86	4.76	34.26
135	17.76	12.65	3.55	28.73
150	16.36	11.65	2.55	22.93

Proposed Nokia Development Storage Calculations Using Average
Novatech Project No. 123043 Release Rate Equal to 50% of the Qpeak
REQUIRED STORAGE - 1:100 YEAR EVENT

AREA A-2 Controlled Site Flows (Lifestyle Street - Lower Side)

OTTAWA IDF CURVE Qpeak = 26.0 L/s
 Area = 0.296 ha Qavg = 13.0 L/s
 C = 0.99 Vol(max) = 117.8 m3
 (Vol calculated for Qallow-avg)

Time (min)	Intensity (mm/hr)	Q (L/s)	Qnet (L/s)	Vol (m3)
5	242.70	198.24	185.24	55.57
10	178.56	145.84	132.84	79.71
15	142.89	116.71	103.71	93.34
20	119.95	97.97	84.97	101.97
25	103.85	84.82	71.82	107.73
30	91.87	75.04	62.04	111.67
35	82.58	67.45	54.45	114.34
40	75.15	61.38	48.38	116.11
45	69.05	56.40	43.40	117.18
50	63.95	52.24	39.24	117.71
55	59.62	48.70	35.70	117.81
60	55.89	45.65	32.65	117.55
65	52.65	43.00	30.00	117.00
70	49.79	40.67	27.67	116.20
75	47.26	38.60	25.60	115.19
90	41.11	33.58	20.58	111.13
105	36.50	29.81	16.81	105.91
120	32.89	26.87	13.87	99.85
135	30.00	24.50	11.50	93.16
150	27.61	22.55	9.55	85.97

Proposed Nokia Development Storage Calculations Using Average
Novatech Project No. 123043 Release Rate Equal to 50% of the Qpeak
REQUIRED STORAGE - 1:100 YR + 20% IDF Increase

AREA A-2 Controlled Site Flows (Lifestyle Street - Lower Side)

OTTAWA IDF CURVE Qpeak = 26.0 L/s
 Area = 0.296 ha Qavg = 13.0 L/s
 C = 0.99 Vol(max) = 150.5 m3
 (Vol calculated for Qallow-avg)

Time (min)	Intensity (mm/hr)	Q (L/s)	Qnet (L/s)	Vol (m3)
5	291.24	237.88	224.88	67.47
10	214.27	175.01	162.01	97.21
15	171.47	140.06	127.06	114.35
20	143.94	117.57	104.57	125.48
25	124.62	101.78	88.78	133.18
30	110.24	90.04	77.04	138.68
35	99.09	80.94	67.94	142.67
40	90.17	73.65	60.65	145.57
45	82.86	67.68	54.68	147.63
50	76.74	62.68	49.68	149.05
55	71.55	58.44	45.44	149.95
60	67.07	54.78	41.78	150.42
65	63.18	51.60	38.60	150.54
70	59.75	48.80	35.80	150.36
75	56.71	46.32	33.32	149.93
90	49.33	40.29	27.29	147.39
105	43.80	35.77	22.77	143.47
120	39.47	32.24	19.24	138.54
135	36.00	29.40	16.40	132.85
150	33.13	27.06	14.06	126.56

Structures	Size (mm)	Area (m ²)	T/G	Inv IN	Inv OUT
UG STORAGE	1144	101.46	79.84		78.16
CBMH 249	1200	1.13	79.80	78.15	78.10
CBMH 250	1200	1.13	79.54	78.05	78.04
CBMH 251	1200	1.13	79.54	78.02	77.92

PI = 3.141592654
 PIPE I.D.= 304.8 PVC
 U/G Storage Pipe Volume
 End Area 0.073 (m²)
 Total Length 21.5 (m)
 Pipe Volume 1.6 (m³)

Area A-2: Storage Table						Underground Storage	Surface Storage								Total Storage		Design Head
Elevation (m)	System Depth (m)	UG STORAGE Volume (m ³)	CBMH 249 Volume (m ³)	CBMH 250 Volume (m ³)	CBMH 251 Volume (m ³)	Combined Volume (m ³)	UG STORAGE		CBMH 249		CBMH 250		CBMH 251		Ponding Volume (m ³)	Total Volume (m ³)	
							Area (m ²)	Volume (m ³)	Area (m ²)	Volume (m ³)	Area (m ²)	Volume (m ³)	Area (m ²)	Volume (m ³)			
77.92	0.00	0.00	0.00	0.00	0.00	1.57	-	-	-	-	-	-	-	-	-	0	-
78.50	0.34	34.50	0.45	0.52	0.66	37.04	-	-	-	-	-	-	-	-	-	37.0	0.43
78.66	0.50	50.73	0.63	0.70	0.84	53.63	-	-	-	-	-	-	-	-	-	53.6	0.59
79.28	1.12	113.64	1.33	1.40	1.54	117.94	-	-	-	-	-	-	-	-	-	117.9	1.21
79.30	1.14	115.66	1.36	1.43	1.56	120.02	-	-	-	-	-	-	-	-	-	120.0	1.23
79.54	1.38	115.66	1.63	1.70	1.83	120.56	0.0	0.00	0.00	0.00	0.00	0.00	0.00	0.00	0.0	120.6	1.47
79.59							0.00	0.00	0.00	0.00	15.59	0.39	15.69	0.39	0.4	120.9	1.52
79.64							0.00	0.00	0.00	0.00	29.27	1.51	29.27	0.00	1.5	122.1	1.57
79.69							0.00	0.00	0.00	0.00	39.37	3.23	39.37	0.00	3.2	123.8	1.62

Tempest HF Type B ICD	
1:100 Yr	
Flow (L/s) = 26.0	Head (m) = 1.21
Elevation (m) = 79.28	Outlet Pipe Dia.(mm) = 304.8
Volume (m3) = 117.8	
1:5 Yr	
Flow (L/s) = 18.2	Head (m) = 0.59
Elevation (m) = 78.66	Outlet Pipe Dia.(mm) = 304.8
Volume (m3) = 53.7	
1:2 Yr	
Flow (L/s) = 15.5	Head (m) = 0.43
Elevation (m) = 78.50	Outlet Pipe Dia.(mm) = 304.8
Volume (m3) = 37.6	

Orifice Size - 1:100 yr Flow Check		
$Q=0.62xAx(2gh)^{0.5}$		
	1:100 yr	Flow Check
Q (m ³ /s) =	0.0260	0.0261
g (m/s ²) =	9.81	9.81
h (m) =	1.21	1.21
A (m ²) =	0.008615304	0.00866
D (m) =	0.104734644	0.10500
D (mm) =	105	105.0

1:5 yr Flow Check	
	1:5 yr
Q (m ³ /s) =	0.0182
g (m/s ²) =	9.81
h (m) =	0.59
A (m ²) =	0.00866
D (m) =	0.105
D (mm) =	105

1:2 yr Flow Check	
	1:2 yr
Q (m ³ /s) =	0.0155
g (m/s ²) =	9.81
h (m) =	0.43
A (m ²) =	0.00866
D (m) =	0.105
D (mm) =	105

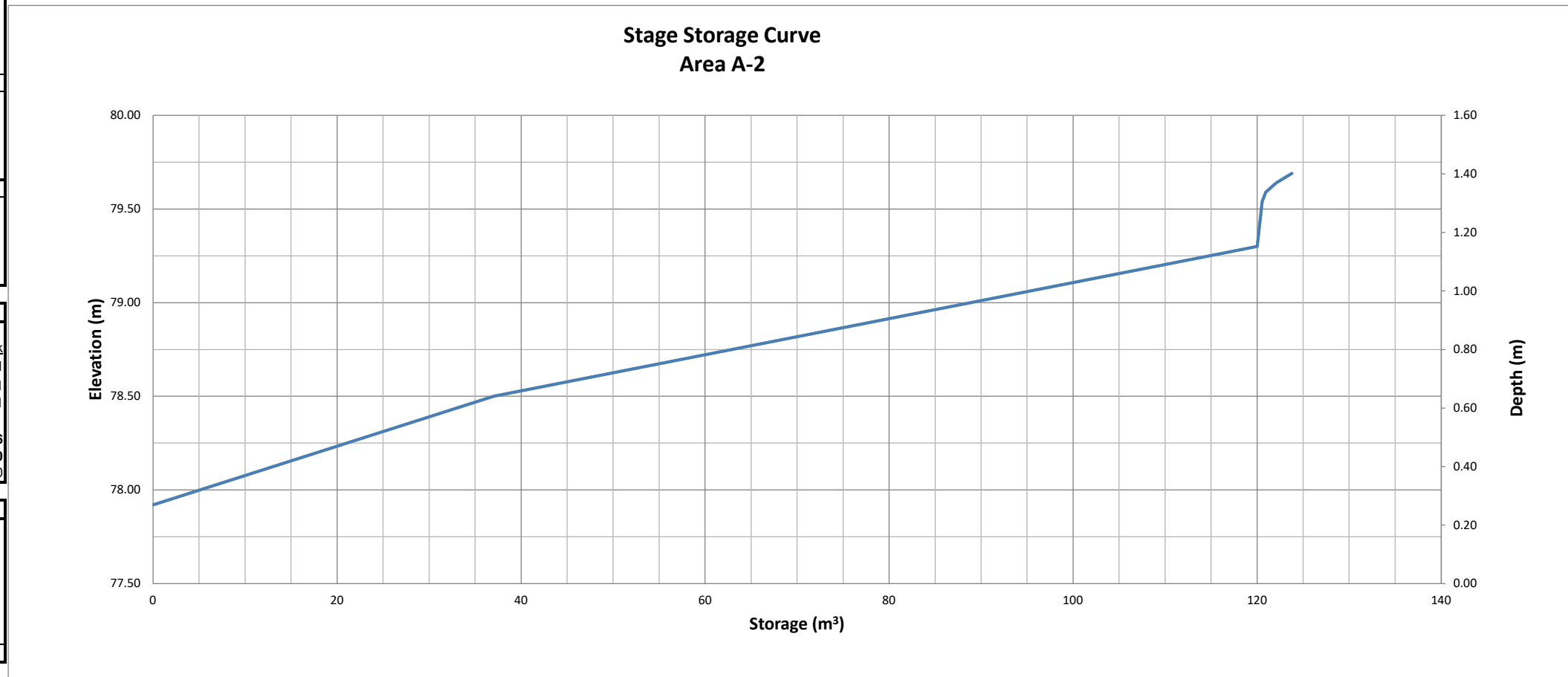

Proposed Nokia Ottawa Innovation Campus					
Novatech Project No. 123043					
REQUIRED STORAGE - 1:2 YEAR EVENT					
AREA A-3			Controlled Roof Drain #1		
OTTAWA IDF CURVE					
Area =	0.049	ha	Qallow =	0.95	L/s
C =	0.90		Vol(max) =	7.5	m3
Time (min)	Intensity (mm/hr)	Q (L/s)	Qnet (L/s)	Vol (m3)	
5	103.57	12.70	11.75	3.52	
10	76.81	9.42	8.47	5.08	
15	61.77	7.57	6.62	5.96	
20	52.03	6.38	5.43	6.51	
25	45.17	5.54	4.59	6.88	
30	40.04	4.91	3.96	7.13	
35	36.06	4.42	3.47	7.29	
40	32.86	4.03	3.08	7.39	
45	30.24	3.71	2.76	7.44	
50	28.04	3.44	2.49	7.46	
55	26.17	3.21	2.26	7.45	
60	24.56	3.01	2.06	7.42	
65	23.15	2.84	1.89	7.36	
70	21.91	2.69	1.74	7.29	
75	20.81	2.55	1.60	7.21	
90	18.14	2.22	1.27	6.88	
105	16.13	1.98	1.03	6.48	
120	14.56	1.79	0.84	6.01	

Proposed Nokia Ottawa Innovation Campus					
Novatech Project No. 123043					
REQUIRED STORAGE - 1:5 YEAR EVENT					
AREA A-3			Controlled Roof Drain #1		
OTTAWA IDF CURVE					
Area =	0.049	ha	Qallow =	1.26	L/s
C =	0.90		Vol(max) =	10.1	m3
Time (min)	Intensity (mm/hr)	Q (L/s)	Qnet (L/s)	Vol (m3)	
5	141.18	17.31	16.05	4.81	
10	104.19	12.77	11.51	6.91	
15	83.56	10.24	8.98	8.09	
20	70.25	8.61	7.35	8.82	
25	60.90	7.47	6.21	9.31	
30	53.93	6.61	5.35	9.63	
35	48.52	5.95	4.69	9.85	
40	44.18	5.42	4.16	9.98	
45	40.63	4.98	3.72	10.05	
50	37.65	4.62	3.36	10.07	
55	35.12	4.31	3.05	10.05	
60	32.94	4.04	2.78	10.00	
65	31.04	3.81	2.55	9.93	
70	29.37	3.60	2.34	9.83	
75	27.89	3.42	2.16	9.72	
90	24.29	2.98	1.72	9.28	
105	21.58	2.65	1.39	8.73	
120	19.47	2.39	1.13	8.11	

Watts Accutrol Flow Control Roof Drains: RD-100-A-ADJ set to fully exposed					
Design Event	Flow/Drain (L/s)	Total Flow (L/s)	Ponding (cm)	Storage (m ³)	
				Required	Provided
1:2 Year	0.95	0.95	8	7.5	
1:5 Year	1.26	1.26	10	10.1	21.2
1:100 Year	1.89	1.89	15	20.6	

Roof Drain Storage Table for Area RD 1		
Elevation	Area RD 1	Total Volume
m	m ²	m ³
0.00	0	0
0.05	52.8	1.3
0.10	177.9	7.1
0.15	384.8	21.2

Proposed Nokia Ottawa Innovation Campus					
Novatech Project No. 123043					
REQUIRED STORAGE - 1:100 YEAR EVENT					
AREA A-3			Controlled Roof Drain #1		
OTTAWA IDF CURVE					
Area =	0.049	ha	Qallow =	1.89	L/s
C =	1.00		Vol(max) =	20.6	m3
Time (min)	Intensity (mm/hr)	Q (L/s)	Qnet (L/s)	Vol (m3)	
5	242.70	33.06	31.17	9.35	
10	178.56	24.32	22.43	13.46	
15	142.89	19.47	17.58	15.82	
20	119.95	16.34	14.45	17.34	
25	103.85	14.15	12.26	18.38	
30	91.87	12.51	10.62	19.12	
35	82.58	11.25	9.36	19.65	
40	75.15	10.24	8.35	20.03	
45	69.05	9.41	7.52	20.29	
50	63.95	8.71	6.82	20.47	
55	59.62	8.12	6.23	20.57	
60	55.89	7.61	5.72	20.61	
80	44.99	6.13	4.24	20.35	
100	37.90	5.16	3.27	19.64	
120	32.89	4.48	2.59	18.65	
140	29.15	3.97	2.08	17.48	
160	26.24	3.57	1.68	16.17	
180	23.90	3.26	1.37	14.75	

Proposed Nokia Ottawa Innovation Campus					
Novatech Project No. 123043					
REQUIRED STORAGE - 1:100 YEAR + 20%					
AREA A-3			Controlled Roof Drain #1		
OTTAWA IDF CURVE					
Area =	0.049	ha	Qallow =	1.89	L/s
C =	1.00		Vol(max) =	26.3	m3
Time (min)	Intensity (mm/hr)	Q (L/s)	Qnet (L/s)	Vol (m3)	
5	291.24	39.67	37.78	11.34	
10	214.27	29.19	27.30	16.38	
15	171.47	23.36	21.47	19.32	
20	143.94	19.61	17.72	21.26	
25	124.62	16.98	15.09	22.63	
30	110.24	15.02	13.13	23.63	
35	99.09	13.50	11.61	24.38	
40	90.17	12.28	10.39	24.94	
45	82.86	11.29	9.40	25.37	
50	76.74	10.45	8.56	25.69	
55	71.55	9.75	7.86	25.93	
60	67.07	9.14	7.25	26.09	
65	63.18	8.61	6.72	26.19	
70	59.75	8.14	6.25	26.25	
75	56.71	7.72	5.83	26.26	
90	49.33	6.72	4.83	26.08	
105	43.80	5.97	4.08	25.68	
120	39.47	5.38	3.49	25.11	

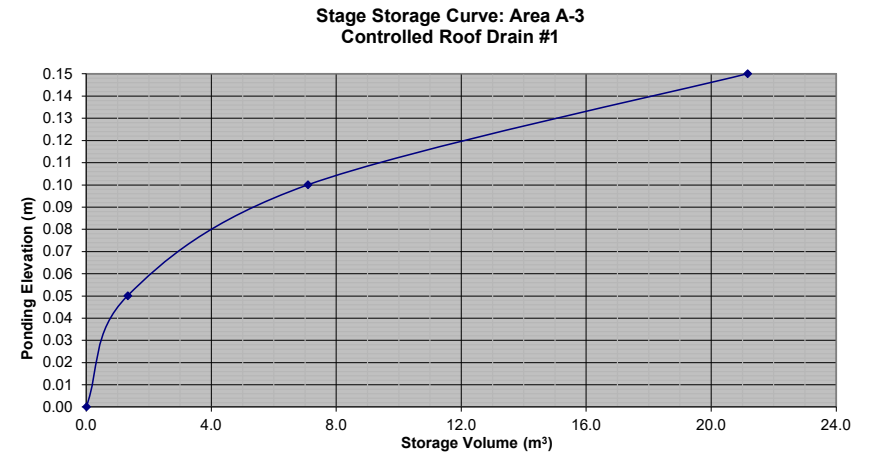

Proposed Nokia Ottawa Innovation Campus					
Novatech Project No. 123043					
REQUIRED STORAGE - 1:2 YEAR EVENT					
AREA A-3		Controlled Roof Drain #2			
OTTAWA IDF CURVE					
Area =	0.049	ha	Qallow =	0.95	L/s
C =	0.90		Vol(max) =	7.5	m3
Time (min)	Intensity (mm/hr)	Q (L/s)	Qnet (L/s)	Vol (m3)	
5	103.57	12.70	11.75	3.52	
10	76.81	9.42	8.47	5.08	
15	61.77	7.57	6.62	5.96	
20	52.03	6.38	5.43	6.51	
25	45.17	5.54	4.59	6.88	
30	40.04	4.91	3.96	7.13	
35	36.06	4.42	3.47	7.29	
40	32.86	4.03	3.08	7.39	
45	30.24	3.71	2.76	7.44	
50	28.04	3.44	2.49	7.46	
55	26.17	3.21	2.26	7.45	
60	24.56	3.01	2.06	7.42	
65	23.15	2.84	1.89	7.36	
70	21.91	2.69	1.74	7.29	
75	20.81	2.55	1.60	7.21	
90	18.14	2.22	1.27	6.88	
105	16.13	1.98	1.03	6.48	
120	14.56	1.79	0.84	6.01	

Proposed Nokia Ottawa Innovation Campus					
Novatech Project No. 123043					
REQUIRED STORAGE - 1:5 YEAR EVENT					
AREA A-3		Controlled Roof Drain #2			
OTTAWA IDF CURVE					
Area =	0.049	ha	Qallow =	1.26	L/s
C =	0.90		Vol(max) =	10.1	m3
Time (min)	Intensity (mm/hr)	Q (L/s)	Qnet (L/s)	Vol (m3)	
5	141.18	17.31	16.05	4.81	
10	104.19	12.77	11.51	6.91	
15	83.56	10.24	8.98	8.09	
20	70.25	8.61	7.35	8.82	
25	60.90	7.47	6.21	9.31	
30	53.93	6.61	5.35	9.63	
35	48.52	5.95	4.69	9.85	
40	44.18	5.42	4.16	9.98	
45	40.63	4.98	3.72	10.05	
50	37.65	4.62	3.36	10.07	
55	35.12	4.31	3.05	10.05	
60	32.94	4.04	2.78	10.00	
65	31.04	3.81	2.55	9.93	
70	29.37	3.60	2.34	9.83	
75	27.89	3.42	2.16	9.72	
90	24.29	2.98	1.72	9.28	
105	21.58	2.65	1.39	8.73	
120	19.47	2.39	1.13	8.11	

Watts Accutrol Flow Control Roof Drains: RD-100-A-ADJ set to fully exposed					
Design Event	Flow/Drain (L/s)	Total Flow (L/s)	Ponding (cm)	Storage (m ³)	
				Required	Provided
1:2 Year	0.95	0.95	8	7.5	
1:5 Year	1.26	1.26	10	10.1	20.8
1:100 Year	1.89	1.89	15	20.6	

Roof Drain Storage Table for Area RD 2		
Elevation	Area RD 1	Total Volume
m	m ²	m ³
0.00	0	0
0.05	52.8	1.3
0.10	174.1	7.0
0.15	378.7	20.8

Proposed Nokia Ottawa Innovation Campus					
Novatech Project No. 123043					
REQUIRED STORAGE - 1:100 YEAR EVENT					
AREA A-3		Controlled Roof Drain #2			
OTTAWA IDF CURVE					
Area =	0.049	ha	Qallow =	1.89	L/s
C =	1.00		Vol(max) =	20.6	m3
Time (min)	Intensity (mm/hr)	Q (L/s)	Qnet (L/s)	Vol (m3)	
5	242.70	33.06	31.17	9.35	
10	178.56	24.32	22.43	13.46	
15	142.89	19.47	17.58	15.82	
20	119.95	16.34	14.45	17.34	
25	103.85	14.15	12.26	18.38	
30	91.87	12.51	10.62	19.12	
35	82.58	11.25	9.36	19.65	
40	75.15	10.24	8.35	20.03	
45	69.05	9.41	7.52	20.29	
50	63.95	8.71	6.82	20.47	
55	59.62	8.12	6.23	20.57	
60	55.89	7.61	5.72	20.61	
80	44.99	6.13	4.24	20.35	
100	37.90	5.16	3.27	19.64	
120	32.89	4.48	2.59	18.65	
140	29.15	3.97	2.08	17.48	
160	26.24	3.57	1.68	16.17	
180	23.90	3.26	1.37	14.75	

Proposed Nokia Ottawa Innovation Campus					
Novatech Project No. 123043					
REQUIRED STORAGE - 1:100 YEAR + 20%					
AREA A-3		Controlled Roof Drain #2			
OTTAWA IDF CURVE					
Area =	0.049	ha	Qallow =	1.89	L/s
C =	1.00		Vol(max) =	26.3	m3
Time (min)	Intensity (mm/hr)	Q (L/s)	Qnet (L/s)	Vol (m3)	
5	291.24	39.67	37.78	11.34	
10	214.27	29.19	27.30	16.38	
15	171.47	23.36	21.47	19.32	
20	143.94	19.61	17.72	21.26	
25	124.62	16.98	15.09	22.63	
30	110.24	15.02	13.13	23.63	
35	99.09	13.50	11.61	24.38	
40	90.17	12.28	10.39	24.94	
45	82.86	11.29	9.40	25.37	
50	76.74	10.45	8.56	25.69	
55	71.55	9.75	7.86	25.93	
60	67.07	9.14	7.25	26.09	
65	63.18	8.61	6.72	26.19	
70	59.75	8.14	6.25	26.25	
75	56.71	7.72	5.83	26.26	
90	49.33	6.72	4.83	26.08	
105	43.80	5.97	4.08	25.68	
120	39.47	5.38	3.49	25.11	

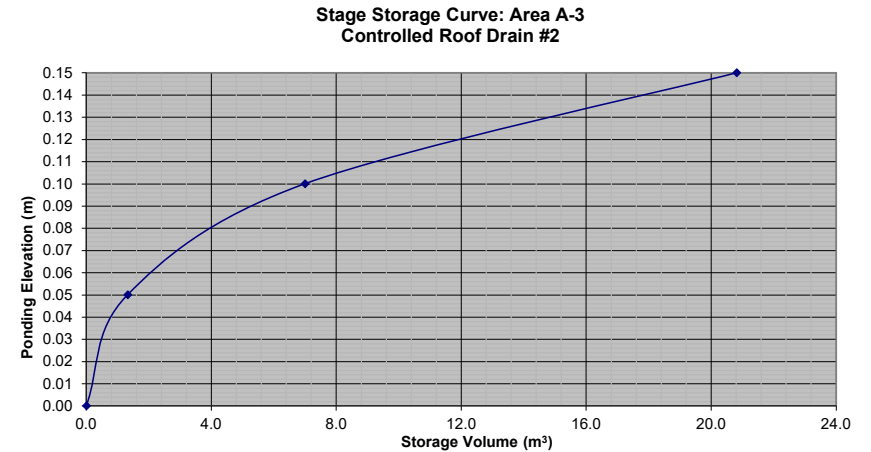

Proposed Nokia Ottawa Innovation Campus					
Novatech Project No. 123043					
REQUIRED STORAGE - 1:2 YEAR EVENT					
AREA A-4		Controlled Roof Drain #1			
OTTAWA IDF CURVE					
Area =	0.037	ha	Qallow =	0.95	L/s
C =	0.90		Vol(max) =	5.0	m3
Time (min)	Intensity (mm/hr)	Q (L/s)	Qnet (L/s)	Vol (m3)	
5	103.57	9.59	8.64	2.59	
10	76.81	7.11	6.16	3.70	
15	61.77	5.72	4.77	4.29	
20	52.03	4.82	3.87	4.64	
25	45.17	4.18	3.23	4.85	
30	40.04	3.71	2.76	4.96	
35	36.06	3.34	2.39	5.02	
40	32.86	3.04	2.09	5.02	
45	30.24	2.80	1.85	4.99	
50	28.04	2.60	1.65	4.94	
55	26.17	2.42	1.47	4.86	
60	24.56	2.27	1.32	4.76	
65	23.15	2.14	1.19	4.65	
70	21.91	2.03	1.08	4.53	
75	20.81	1.93	0.98	4.40	
90	18.14	1.68	0.73	3.94	
105	16.13	1.49	0.54	3.42	
120	14.56	1.35	0.40	2.87	

Proposed Nokia Ottawa Innovation Campus					
Novatech Project No. 123043					
REQUIRED STORAGE - 1:5 YEAR EVENT					
AREA A-4		Controlled Roof Drain #1			
OTTAWA IDF CURVE					
Area =	0.037	ha	Qallow =	1.26	L/s
C =	0.90		Vol(max) =	6.8	m3
Time (min)	Intensity (mm/hr)	Q (L/s)	Qnet (L/s)	Vol (m3)	
5	141.18	13.07	11.81	3.54	
10	104.19	9.65	8.39	5.03	
15	83.56	7.74	6.48	5.83	
20	70.25	6.50	5.24	6.29	
25	60.90	5.64	4.38	6.57	
30	53.93	4.99	3.73	6.72	
35	48.52	4.49	3.23	6.79	
40	44.18	4.09	2.83	6.79	
45	40.63	3.76	2.50	6.75	
50	37.65	3.49	2.23	6.68	
55	35.12	3.25	1.99	6.57	
60	32.94	3.05	1.79	6.44	
65	31.04	2.87	1.61	6.29	
70	29.37	2.72	1.46	6.13	
75	27.89	2.58	1.32	5.95	
90	24.29	2.25	0.99	5.34	
105	21.58	2.00	0.74	4.65	
120	19.47	1.80	0.54	3.90	

Watts Accutrol Flow Control Roof Drains: RD-100-A-ADJ set to fully exposed					
Design Event	Flow/Drain (L/s)	Total Flow (L/s)	Ponding (cm)	Storage (m ³)	
				Required	Provided
1:2 Year	0.95	0.95	8	5.0	
1:5 Year	1.26	1.26	10	6.8	14.5
1:100 Year	1.89	1.89	15	14.1	

Roof Drain Storage Table for Area RD 1		
Elevation	Area RD 1	Total Volume
m	m ²	m ³
0.00	0	0
0.05	30.6	0.8
0.10	122.3	4.6
0.15	274.1	14.5

Stage Storage Curve: Area A-4
 Controlled Roof Drain #1

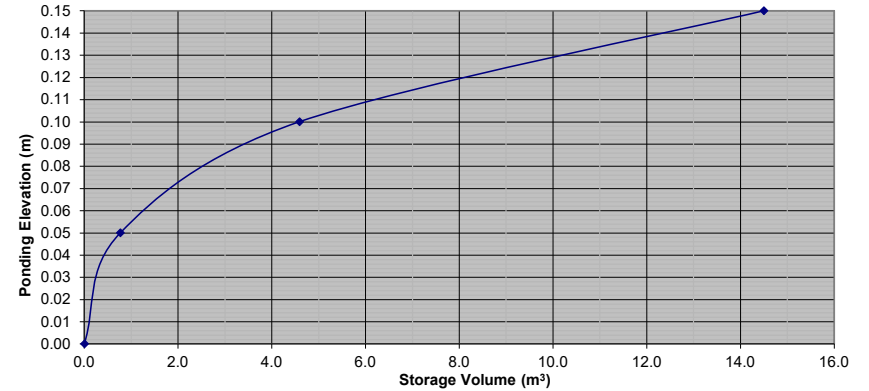

Proposed Nokia Ottawa Innovation Campus					
Novatech Project No. 123043					
REQUIRED STORAGE - 1:100 YEAR EVENT					
AREA A-4		Controlled Roof Drain #1			
OTTAWA IDF CURVE					
Area =	0.037	ha	Qallow =	1.89	L/s
C =	1.00		Vol(max) =	14.1	m3
Time (min)	Intensity (mm/hr)	Q (L/s)	Qnet (L/s)	Vol (m3)	
5	242.70	24.96	23.07	6.92	
10	178.56	18.37	16.48	9.89	
15	142.89	14.70	12.81	11.53	
20	119.95	12.34	10.45	12.54	
25	103.85	10.68	8.79	13.19	
30	91.87	9.45	7.56	13.61	
35	82.58	8.49	6.60	13.87	
40	75.15	7.73	5.84	14.01	
45	69.05	7.10	5.21	14.07	
50	63.95	6.58	4.69	14.06	
55	59.62	6.13	4.24	14.00	
60	55.89	5.75	3.86	13.89	
80	44.99	4.63	2.74	13.14	
100	37.90	3.90	2.01	12.05	
120	32.89	3.38	1.49	10.75	
140	29.15	3.00	1.11	9.31	
160	26.24	2.70	0.81	7.77	
180	23.90	2.46	0.57	6.14	

Proposed Nokia Ottawa Innovation Campus					
Novatech Project No. 123043					
REQUIRED STORAGE - 1:100 YEAR + 20%					
AREA A-4		Controlled Roof Drain #1			
OTTAWA IDF CURVE					
Area =	0.037	ha	Qallow =	1.89	L/s
C =	1.00		Vol(max) =	18.0	m3
Time (min)	Intensity (mm/hr)	Q (L/s)	Qnet (L/s)	Vol (m3)	
5	291.24	29.96	28.07	8.42	
10	214.27	22.04	20.15	12.09	
15	171.47	17.64	15.75	14.17	
20	143.94	14.81	12.92	15.50	
25	124.62	12.82	10.93	16.39	
30	110.24	11.34	9.45	17.01	
35	99.09	10.19	8.30	17.44	
40	90.17	9.28	7.39	17.72	
45	82.86	8.52	6.63	17.91	
50	76.74	7.89	6.00	18.01	
55	71.55	7.36	5.47	18.05	
60	67.07	6.90	5.01	18.03	
65	63.18	6.50	4.61	17.97	
70	59.75	6.15	4.26	17.87	
75	56.71	5.83	3.94	17.74	
90	49.33	5.07	3.18	17.20	
105	43.80	4.50	2.61	16.47	
120	39.47	4.06	2.17	15.63	

Proposed Nokia Ottawa Innovation Campus					
Novatech Project No. 123043					
REQUIRED STORAGE - 1:2 YEAR EVENT					
AREA A-4		Controlled Roof Drain #2			
OTTAWA IDF CURVE					
Area =	0.038	ha	Qallow =	0.95	L/s
C =	0.90		Vol(max) =	5.2	m ³
Time (min)	Intensity (mm/hr)	Q (L/s)	Qnet (L/s)	Vol (m ³)	
5	103.57	9.85	8.90	2.67	
10	76.81	7.30	6.35	3.81	
15	61.77	5.87	4.92	4.43	
20	52.03	4.95	4.00	4.80	
25	45.17	4.29	3.34	5.02	
30	40.04	3.81	2.86	5.14	
35	36.06	3.43	2.48	5.20	
40	32.86	3.12	2.17	5.22	
45	30.24	2.88	1.93	5.20	
50	28.04	2.67	1.72	5.15	
55	26.17	2.49	1.54	5.08	
60	24.56	2.33	1.38	4.99	
65	23.15	2.20	1.25	4.88	
70	21.91	2.08	1.13	4.76	
75	20.81	1.98	1.03	4.63	
90	18.14	1.72	0.77	4.18	
105	16.13	1.53	0.58	3.68	
120	14.56	1.38	0.43	3.13	

Proposed Nokia Ottawa Innovation Campus					
Novatech Project No. 123043					
REQUIRED STORAGE - 1:5 YEAR EVENT					
AREA A-4		Controlled Roof Drain #2			
OTTAWA IDF CURVE					
Area =	0.038	ha	Qallow =	1.26	L/s
C =	0.90		Vol(max) =	7.1	m ³
Time (min)	Intensity (mm/hr)	Q (L/s)	Qnet (L/s)	Vol (m ³)	
5	141.18	13.42	12.16	3.65	
10	104.19	9.91	8.65	5.19	
15	83.56	7.94	6.68	6.02	
20	70.25	6.68	5.42	6.50	
25	60.90	5.79	4.53	6.79	
30	53.93	5.13	3.87	6.96	
35	48.52	4.61	3.35	7.04	
40	44.18	4.20	2.94	7.06	
45	40.63	3.86	2.60	7.03	
50	37.65	3.58	2.32	6.96	
55	35.12	3.34	2.08	6.86	
60	32.94	3.13	1.87	6.74	
65	31.04	2.95	1.69	6.60	
70	29.37	2.79	1.53	6.44	
75	27.89	2.65	1.39	6.26	
90	24.29	2.31	1.05	5.67	
105	21.58	2.05	0.79	4.99	
120	19.47	1.85	0.59	4.25	

Watts Accutrol Flow Control Roof Drains: RD-100-A-ADJ set to fully exposed					
Design Event	Flow/Drain (L/s)	Total Flow (L/s)	Storage (m ³)		
			Ponding (cm)	Required	Provided
1:2 Year	0.95	0.95	8	5.2	
1:5 Year	1.26	1.26	10	7.1	15.4
1:100 Year	1.89	1.89	15	14.6	

Roof Drain Storage Table for Area RD 2		
Elevation	Area RD 1	Total Volume
m	m ²	m ³
0.00	0	0
0.05	32.5	0.8
0.10	129.3	4.9
0.15	292.5	15.4

Proposed Nokia Ottawa Innovation Campus					
Novatech Project No. 123043					
REQUIRED STORAGE - 1:100 YEAR EVENT					
AREA A-4		Controlled Roof Drain #2			
OTTAWA IDF CURVE					
Area =	0.038	ha	Qallow =	1.89	L/s
C =	1.00		Vol(max) =	14.6	m ³
Time (min)	Intensity (mm/hr)	Q (L/s)	Qnet (L/s)	Vol (m ³)	
5	242.70	25.64	23.75	7.12	
10	178.56	18.86	16.97	10.18	
15	142.89	15.10	13.21	11.88	
20	119.95	12.67	10.78	12.94	
25	103.85	10.97	9.08	13.62	
30	91.87	9.70	7.81	14.07	
35	82.58	8.72	6.83	14.35	
40	75.15	7.94	6.05	14.52	
45	69.05	7.29	5.40	14.59	
50	63.95	6.76	4.87	14.60	
55	59.62	6.30	4.41	14.55	
60	55.89	5.90	4.01	14.45	
80	44.99	4.75	2.86	13.74	
100	37.90	4.00	2.11	12.68	
120	32.89	3.48	1.59	11.41	
140	29.15	3.08	1.19	9.99	
160	26.24	2.77	0.88	8.47	
180	23.90	2.53	0.64	6.86	

Proposed Nokia Ottawa Innovation Campus					
Novatech Project No. 123043					
REQUIRED STORAGE - 1:100 YEAR + 20%					
AREA A-4		Controlled Roof Drain #2			
OTTAWA IDF CURVE					
Area =	0.038	ha	Qallow =	1.89	L/s
C =	1.00		Vol(max) =	18.7	m ³
Time (min)	Intensity (mm/hr)	Q (L/s)	Qnet (L/s)	Vol (m ³)	
5	291.24	30.77	28.88	8.66	
10	214.27	22.64	20.75	12.45	
15	171.47	18.11	16.22	14.60	
20	143.94	15.21	13.32	15.98	
25	124.62	13.16	11.27	16.91	
30	110.24	11.65	9.76	17.56	
35	99.09	10.47	8.58	18.01	
40	90.17	9.53	7.64	18.33	
45	82.86	8.75	6.86	18.53	
50	76.74	8.11	6.22	18.65	
55	71.55	7.56	5.67	18.71	
60	67.07	7.09	5.20	18.70	
65	63.18	6.67	4.78	18.66	
70	59.75	6.31	4.42	18.57	
75	56.71	5.99	4.10	18.45	
90	49.33	5.21	3.32	17.94	
105	43.80	4.63	2.74	17.24	
120	39.47	4.17	2.28	16.42	

Stage Storage Curve: Area A-4
 Controlled Roof Drain #2

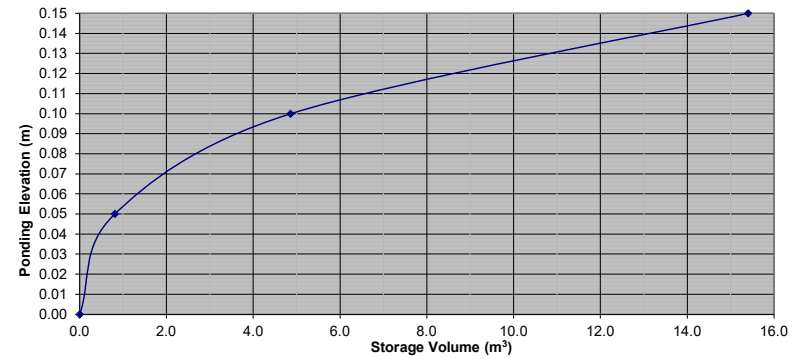

Proposed Nokia Ottawa Innovation Campus					
Novatech Project No. 123043					
REQUIRED STORAGE - 1:2 YEAR EVENT					
AREA A-5 Controlled Roof Drain #1					
OTTAWA IDF CURVE					
Area =	0.010	ha	Qallow =	0.32	L/s
C =	0.90		Vol(max) =	1.2	m3
Time (min)	Intensity (mm/hr)	Q (L/s)	Qnet (L/s)	Vol (m3)	
5	103.57	2.54	2.22	0.67	
10	76.81	1.88	1.56	0.94	
15	61.77	1.51	1.19	1.08	
20	52.03	1.28	0.96	1.15	
25	45.17	1.11	0.79	1.18	
30	40.04	0.98	0.66	1.19	
35	36.06	0.88	0.56	1.18	
40	32.86	0.81	0.49	1.17	
45	30.24	0.74	0.42	1.14	
50	28.04	0.69	0.37	1.10	
55	26.17	0.64	0.32	1.06	
60	24.56	0.60	0.28	1.02	
65	23.15	0.57	0.25	0.97	
70	21.91	0.54	0.22	0.91	
75	20.81	0.51	0.19	0.86	
90	18.14	0.44	0.12	0.67	
105	16.13	0.40	0.08	0.48	
120	14.56	0.36	0.04	0.27	

Proposed Nokia Ottawa Innovation Campus					
Novatech Project No. 123043					
REQUIRED STORAGE - 1:5 YEAR EVENT					
AREA A-5 Controlled Roof Drain #1					
OTTAWA IDF CURVE					
Area =	0.010	ha	Qallow =	0.32	L/s
C =	0.90		Vol(max) =	1.8	m3
Time (min)	Intensity (mm/hr)	Q (L/s)	Qnet (L/s)	Vol (m3)	
5	141.18	3.46	3.14	0.94	
10	104.19	2.55	2.23	1.34	
15	83.56	2.05	1.73	1.56	
20	70.25	1.72	1.40	1.68	
25	60.90	1.49	1.17	1.76	
30	53.93	1.32	1.00	1.80	
35	48.52	1.19	0.87	1.83	
40	44.18	1.08	0.76	1.83	
45	40.63	1.00	0.68	1.83	
50	37.65	0.92	0.60	1.81	
55	35.12	0.86	0.54	1.79	
60	32.94	0.81	0.49	1.76	
65	31.04	0.76	0.44	1.72	
70	29.37	0.72	0.40	1.68	
75	27.89	0.68	0.36	1.64	
90	24.29	0.60	0.28	1.49	
105	21.58	0.53	0.21	1.32	
120	19.47	0.48	0.16	1.13	

Watts Accutrol Flow Control Roof Drains: RD-100-A-ADJ set to closed					
Design Event	Flow/Drain (L/s)	Total Flow (L/s)	Ponding (cm)	Required Storage (m ³)	Provided
1:2 Year	0.32	0.32	8	1.2	
1:5 Year	0.32	0.32	10	1.8	5.1
1:100 Year	0.32	0.32	15	4.3	

Roof Drain Storage Table for Area RD 1		
Elevation	Area RD 1	Total Volume
m	m ²	m ³
0.00	0	0
0.05	10.8	0.3
0.10	43.3	1.6
0.15	97.6	5.1

Proposed Nokia Ottawa Innovation Campus					
Novatech Project No. 123043					
REQUIRED STORAGE - 1:100 YEAR EVENT					
AREA A-5 Controlled Roof Drain #1					
OTTAWA IDF CURVE					
Area =	0.010	ha	Qallow =	0.32	L/s
C =	1.00		Vol(max) =	4.3	m3
Time (min)	Intensity (mm/hr)	Q (L/s)	Qnet (L/s)	Vol (m3)	
5	242.70	6.61	6.29	1.89	
10	178.56	4.86	4.54	2.73	
15	142.89	3.89	3.57	3.22	
20	119.95	3.27	2.95	3.54	
25	103.85	2.83	2.51	3.76	
30	91.87	2.50	2.18	3.93	
35	82.58	2.25	1.93	4.05	
40	75.15	2.05	1.73	4.15	
45	69.05	1.88	1.56	4.22	
50	63.95	1.74	1.42	4.27	
55	59.62	1.62	1.30	4.30	
60	55.89	1.52	1.20	4.33	
80	44.99	1.23	0.91	4.35	
100	37.90	1.03	0.71	4.28	
120	32.89	0.90	0.58	4.15	
140	29.15	0.79	0.47	3.98	
160	26.24	0.71	0.39	3.79	
180	23.90	0.65	0.33	3.58	

Proposed Nokia Ottawa Innovation Campus					
Novatech Project No. 123043					
REQUIRED STORAGE - 1:100 YEAR + 20%					
AREA A-5 Controlled Roof Drain #1					
OTTAWA IDF CURVE					
Area =	0.010	ha	Qallow =	0.32	L/s
C =	1.00		Vol(max) =	5.5	m3
Time (min)	Intensity (mm/hr)	Q (L/s)	Qnet (L/s)	Vol (m3)	
5	291.24	7.93	7.61	2.28	
10	214.27	5.84	5.52	3.31	
15	171.47	4.67	4.35	3.92	
20	143.94	3.92	3.60	4.32	
25	124.62	3.40	3.08	4.61	
30	110.24	3.00	2.68	4.83	
35	99.09	2.70	2.38	5.00	
40	90.17	2.46	2.14	5.13	
45	82.86	2.26	1.94	5.23	
50	76.74	2.09	1.77	5.31	
55	71.55	1.95	1.63	5.38	
60	67.07	1.83	1.51	5.43	
65	63.18	1.72	1.40	5.46	
70	59.75	1.63	1.31	5.49	
75	56.71	1.54	1.22	5.51	
90	49.33	1.34	1.02	5.53	
105	43.80	1.19	0.87	5.50	
120	39.47	1.08	0.76	5.44	

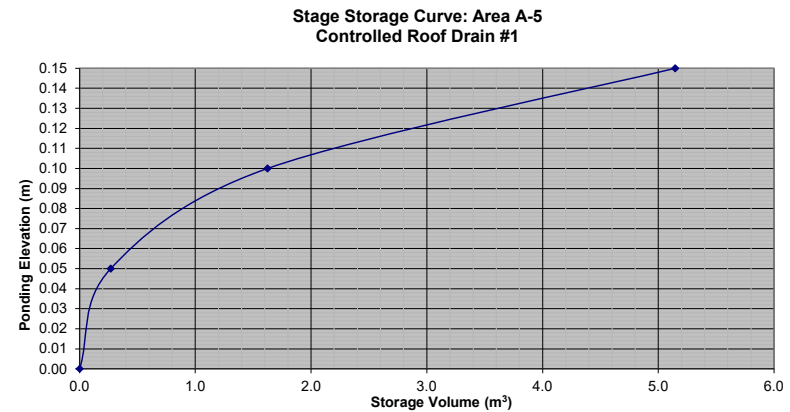

Proposed Nokia Ottawa Innovation Campus					
Novatech Project No. 123043					
REQUIRED STORAGE - 1:2 YEAR EVENT					
AREA A-5			Controlled Roof Drain #2		
OTTAWA IDF CURVE					
Area =	0.014	ha	Qallow =	0.32	L/s
C =	0.90		Vol(max) =	1.9	m3
Time (min)	Intensity (mm/hr)	Q (L/s)	Qnet (L/s)	Vol (m3)	
5	103.57	3.50	3.18	0.95	
10	76.81	2.59	2.27	1.36	
15	61.77	2.09	1.77	1.59	
20	52.03	1.76	1.44	1.72	
25	45.17	1.53	1.21	1.81	
30	40.04	1.35	1.03	1.86	
35	36.06	1.22	0.90	1.89	
40	32.86	1.11	0.79	1.90	
45	30.24	1.02	0.70	1.89	
50	28.04	0.95	0.63	1.88	
55	26.17	0.88	0.56	1.86	
60	24.56	0.83	0.51	1.83	
65	23.15	0.78	0.46	1.80	
70	21.91	0.74	0.42	1.76	
75	20.81	0.70	0.38	1.72	
90	18.14	0.61	0.29	1.58	
105	16.13	0.54	0.22	1.42	
120	14.56	0.49	0.17	1.24	

Proposed Nokia Ottawa Innovation Campus					
Novatech Project No. 123043					
REQUIRED STORAGE - 1:5 YEAR EVENT					
AREA A-5			Controlled Roof Drain #2		
OTTAWA IDF CURVE					
Area =	0.014	ha	Qallow =	0.32	L/s
C =	0.90		Vol(max) =	2.9	m3
Time (min)	Intensity (mm/hr)	Q (L/s)	Qnet (L/s)	Vol (m3)	
5	141.18	4.77	4.45	1.33	
10	104.19	3.52	3.20	1.92	
15	83.56	2.82	2.50	2.25	
20	70.25	2.37	2.05	2.46	
25	60.90	2.06	1.74	2.61	
30	53.93	1.82	1.50	2.70	
35	48.52	1.64	1.32	2.77	
40	44.18	1.49	1.17	2.81	
45	40.63	1.37	1.05	2.84	
50	37.65	1.27	0.95	2.86	
55	35.12	1.19	0.87	2.86	
60	32.94	1.11	0.79	2.85	
65	31.04	1.05	0.73	2.84	
70	29.37	0.99	0.67	2.82	
75	27.89	0.94	0.62	2.80	
90	24.29	0.82	0.50	2.70	
105	21.58	0.73	0.41	2.58	
120	19.47	0.66	0.34	2.43	

Watts Accutrol Flow Control Roof Drains: RD-100-A-ADJ set to closed					
Design Event	Flow/Drain (L/s)	Total Flow (L/s)	Ponding (cm)	Storage (m ³) Required	Storage (m ³) Provided
1:2 Year	0.32	0.32	8	1.9	
1:5 Year	0.32	0.32	10	2.9	7.1
1:100 Year	0.32	0.32	15	6.6	

Roof Drain Storage Table for Area RD 2		
Elevation	Area RD 1	Total Volume
m	m ²	m ³
0.00	0	0
0.05	14.8	0.4
0.10	59.1	2.2
0.15	136.1	7.1

Stage Storage Curve: Area A-5
 Controlled Roof Drain #2

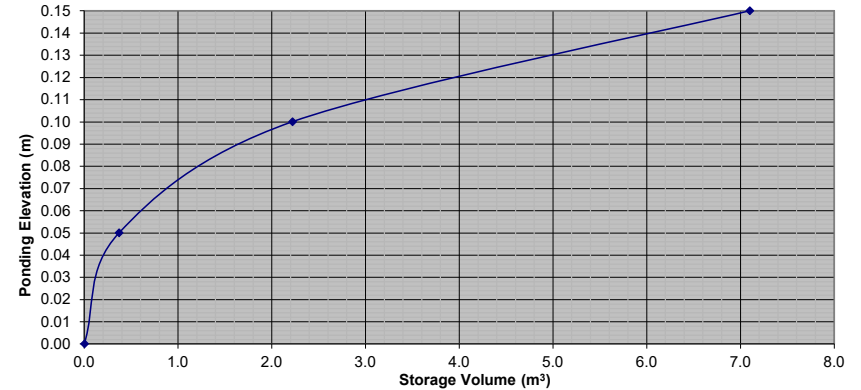

Proposed Nokia Ottawa Innovation Campus					
Novatech Project No. 123043					
REQUIRED STORAGE - 1:100 YEAR EVENT					
AREA A-5			Controlled Roof Drain #2		
OTTAWA IDF CURVE					
Area =	0.014	ha	Qallow =	0.32	L/s
C =	1.00		Vol(max) =	6.6	m3
Time (min)	Intensity (mm/hr)	Q (L/s)	Qnet (L/s)	Vol (m3)	
5	242.70	9.11	8.79	2.64	
10	178.56	6.70	6.38	3.83	
15	142.89	5.36	5.04	4.54	
20	119.95	4.50	4.18	5.02	
25	103.85	3.90	3.58	5.37	
30	91.87	3.45	3.13	5.63	
35	82.58	3.10	2.78	5.84	
40	75.15	2.82	2.50	6.00	
45	69.05	2.59	2.27	6.13	
50	63.95	2.40	2.08	6.24	
55	59.62	2.24	1.92	6.33	
60	55.89	2.10	1.78	6.40	
80	44.99	1.69	1.37	6.57	
100	37.90	1.42	1.10	6.62	
120	32.89	1.23	0.91	6.58	
140	29.15	1.09	0.77	6.50	
160	26.24	0.98	0.66	6.38	
180	23.90	0.90	0.58	6.23	

Proposed Nokia Ottawa Innovation Campus					
Novatech Project No. 123043					
REQUIRED STORAGE - 1:100 YEAR + 20%					
AREA A-5			Controlled Roof Drain #2		
OTTAWA IDF CURVE					
Area =	0.014	ha	Qallow =	0.32	L/s
C =	1.00		Vol(max) =	8.4	m3
Time (min)	Intensity (mm/hr)	Q (L/s)	Qnet (L/s)	Vol (m3)	
5	291.24	10.93	10.61	3.18	
10	214.27	8.04	7.72	4.63	
15	171.47	6.44	6.12	5.50	
20	143.94	5.40	5.08	6.10	
25	124.62	4.68	4.36	6.54	
30	110.24	4.14	3.82	6.87	
35	99.09	3.72	3.40	7.14	
40	90.17	3.38	3.06	7.35	
45	82.86	3.11	2.79	7.53	
50	76.74	2.88	2.56	7.68	
55	71.55	2.69	2.37	7.81	
60	67.07	2.52	2.20	7.91	
65	63.18	2.37	2.05	8.00	
70	59.75	2.24	1.92	8.07	
75	56.71	2.13	1.81	8.14	
90	49.33	1.85	1.53	8.27	
105	43.80	1.64	1.32	8.34	
120	39.47	1.48	1.16	8.36	

Proposed Nokia Ottawa Innovation Campus					
Novatech Project No. 123043					
REQUIRED STORAGE - 1:2 YEAR EVENT					
AREA A-5		Controlled Roof Drain #3			
OTTAWA IDF CURVE					
Area =	0.007	ha	Qallow =	0.32	L/s
C =	0.90		Vol(max) =	0.7	m3
Time (min)	Intensity (mm/hr)	Q (L/s)	Qnet (L/s)	Vol (m3)	
5	103.57	1.74	1.42	0.42	
10	76.81	1.29	0.97	0.58	
15	61.77	1.04	0.72	0.64	
20	52.03	0.87	0.55	0.66	
25	45.17	0.76	0.44	0.66	
30	40.04	0.67	0.35	0.63	
35	36.06	0.60	0.28	0.60	
40	32.86	0.55	0.23	0.55	
45	30.24	0.51	0.19	0.50	
50	28.04	0.47	0.15	0.45	
55	26.17	0.44	0.12	0.39	
60	24.56	0.41	0.09	0.33	
65	23.15	0.39	0.07	0.27	
70	21.91	0.37	0.05	0.20	
75	20.81	0.35	0.03	0.13	
90	18.14	0.30	-0.02	-0.09	
105	16.13	0.27	-0.05	-0.31	
120	14.56	0.24	-0.08	-0.55	

Proposed Nokia Ottawa Innovation Campus					
Novatech Project No. 123043					
REQUIRED STORAGE - 1:5 YEAR EVENT					
AREA A-5		Controlled Roof Drain #3			
OTTAWA IDF CURVE					
Area =	0.007	ha	Qallow =	0.32	L/s
C =	0.90		Vol(max) =	1.1	m3
Time (min)	Intensity (mm/hr)	Q (L/s)	Qnet (L/s)	Vol (m3)	
5	141.18	2.37	2.05	0.61	
10	104.19	1.75	1.43	0.86	
15	83.56	1.40	1.08	0.97	
20	70.25	1.18	0.86	1.03	
25	60.90	1.02	0.70	1.05	
30	53.93	0.90	0.58	1.05	
35	48.52	0.81	0.49	1.04	
40	44.18	0.74	0.42	1.01	
45	40.63	0.68	0.36	0.97	
50	37.65	0.63	0.31	0.93	
55	35.12	0.59	0.27	0.89	
60	32.94	0.55	0.23	0.84	
65	31.04	0.52	0.20	0.78	
70	29.37	0.49	0.17	0.72	
75	27.89	0.47	0.15	0.66	
90	24.29	0.41	0.09	0.47	
105	21.58	0.36	0.04	0.26	
120	19.47	0.33	0.01	0.05	

Watts Accutrol Flow Control Roof Drains: RD-100-A-ADJ set to closed					
Design Event	Flow/Drain (L/s)	Total Flow (L/s)	Ponding (cm)	Storage (m ³) Required	Storage (m ³) Provided
1:2 Year	0.32	0.32	8	0.7	
1:5 Year	0.32	0.32	10	1.1	2.9
1:100 Year	0.32	0.32	15	2.6	

Roof Drain Storage Table for Area RD 3		
Elevation	Area RD 1	Total Volume
m	m ²	m ³
0.00	0	0
0.05	5.1	0.1
0.10	20.2	0.8
0.15	66.7	2.9

Stage Storage Curve: Area A-5
 Controlled Roof Drain #3

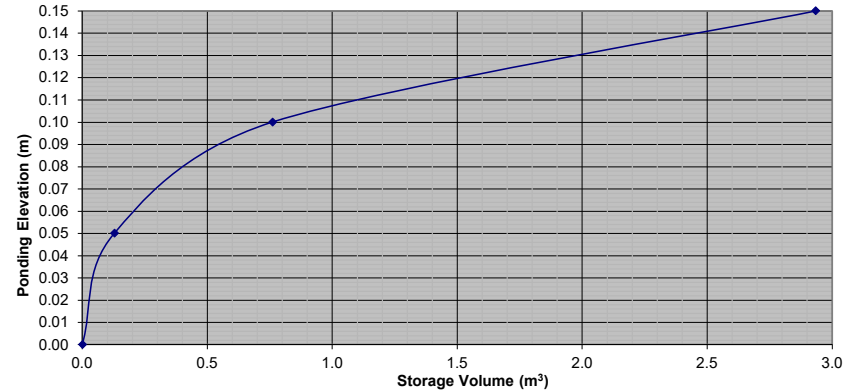

Proposed Nokia Ottawa Innovation Campus					
Novatech Project No. 123043					
REQUIRED STORAGE - 1:100 YEAR EVENT					
AREA A-5		Controlled Roof Drain #3			
OTTAWA IDF CURVE					
Area =	0.007	ha	Qallow =	0.32	L/s
C =	1.00		Vol(max) =	2.6	m3
Time (min)	Intensity (mm/hr)	Q (L/s)	Qnet (L/s)	Vol (m3)	
5	242.70	4.52	4.20	1.26	
10	178.56	3.33	3.01	1.80	
15	142.89	2.66	2.34	2.11	
20	119.95	2.23	1.91	2.30	
25	103.85	1.93	1.61	2.42	
30	91.87	1.71	1.39	2.50	
35	82.58	1.54	1.22	2.56	
40	75.15	1.40	1.08	2.59	
45	69.05	1.29	0.97	2.61	
50	63.95	1.19	0.87	2.61	
55	59.62	1.11	0.79	2.61	
60	55.89	1.04	0.72	2.60	
80	44.99	0.84	0.52	2.49	
100	37.90	0.71	0.39	2.32	
120	32.89	0.61	0.29	2.11	
140	29.15	0.54	0.22	1.87	
160	26.24	0.49	0.17	1.62	
180	23.90	0.45	0.13	1.35	

Proposed Nokia Ottawa Innovation Campus					
Novatech Project No. 123043					
REQUIRED STORAGE - 1:100 YEAR + 20%					
AREA A-5		Controlled Roof Drain #3			
OTTAWA IDF CURVE					
Area =	0.007	ha	Qallow =	0.32	L/s
C =	1.00		Vol(max) =	3.3	m3
Time (min)	Intensity (mm/hr)	Q (L/s)	Qnet (L/s)	Vol (m3)	
5	291.24	5.42	5.10	1.53	
10	214.27	3.99	3.67	2.20	
15	171.47	3.19	2.87	2.59	
20	143.94	2.68	2.36	2.83	
25	124.62	2.32	2.00	3.00	
30	110.24	2.05	1.73	3.12	
35	99.09	1.85	1.53	3.20	
40	90.17	1.68	1.36	3.26	
45	82.86	1.54	1.22	3.30	
50	76.74	1.43	1.11	3.33	
55	71.55	1.33	1.01	3.34	
60	67.07	1.25	0.93	3.35	
65	63.18	1.18	0.86	3.34	
70	59.75	1.11	0.79	3.33	
75	56.71	1.06	0.74	3.31	
90	49.33	0.92	0.60	3.23	
105	43.80	0.82	0.50	3.12	
120	39.47	0.74	0.42	2.99	

Proposed Nokia Ottawa Innovation Campus					
Novatech Project No. 123043					
REQUIRED STORAGE - 1:2 YEAR EVENT					
AREA A-5		Controlled Roof Drain #4			
OTTAWA IDF CURVE					
Area =	0.006	ha	Qallow =	0.32	L/s
C =	0.90		Vol(max) =	0.6	m3
Time (min)	Intensity (mm/hr)	Q (L/s)	Qnet (L/s)	Vol (m3)	
5	103.57	1.65	1.33	0.40	
10	76.81	1.22	0.90	0.54	
15	61.77	0.98	0.66	0.60	
20	52.03	0.83	0.51	0.61	
25	45.17	0.72	0.40	0.60	
30	40.04	0.64	0.32	0.57	
35	36.06	0.57	0.25	0.53	
40	32.86	0.52	0.20	0.49	
45	30.24	0.48	0.16	0.43	
50	28.04	0.45	0.13	0.38	
55	26.17	0.42	0.10	0.32	
60	24.56	0.39	0.07	0.25	
65	23.15	0.37	0.05	0.19	
70	21.91	0.35	0.03	0.12	
75	20.81	0.33	0.01	0.05	
90	18.14	0.29	-0.03	-0.17	
105	16.13	0.26	-0.06	-0.40	
120	14.56	0.23	-0.09	-0.64	

Proposed Nokia Ottawa Innovation Campus					
Novatech Project No. 123043					
REQUIRED STORAGE - 1:5 YEAR EVENT					
AREA A-5		Controlled Roof Drain #4			
OTTAWA IDF CURVE					
Area =	0.006	ha	Qallow =	0.32	L/s
C =	0.90		Vol(max) =	1.0	m3
Time (min)	Intensity (mm/hr)	Q (L/s)	Qnet (L/s)	Vol (m3)	
5	141.18	2.24	1.92	0.58	
10	104.19	1.66	1.34	0.80	
15	83.56	1.33	1.01	0.91	
20	70.25	1.12	0.80	0.96	
25	60.90	0.97	0.65	0.97	
30	53.93	0.86	0.54	0.97	
35	48.52	0.77	0.45	0.95	
40	44.18	0.70	0.38	0.92	
45	40.63	0.65	0.33	0.88	
50	37.65	0.60	0.28	0.83	
55	35.12	0.56	0.24	0.79	
60	32.94	0.52	0.20	0.73	
65	31.04	0.49	0.17	0.68	
70	29.37	0.47	0.15	0.62	
75	27.89	0.44	0.12	0.55	
90	24.29	0.39	0.07	0.36	
105	21.58	0.34	0.02	0.14	
120	19.47	0.31	-0.01	-0.08	

Watts Accutrol Flow Control Roof Drains: RD-100-A-ADJ set to closed					
Design Event	Flow/Drain (L/s)	Total Flow (L/s)	Ponding (cm)	Storage Required (m ³)	Storage Provided (m ³)
1:2 Year	0.32	0.32	8	0.6	
1:5 Year	0.32	0.32	10	1.0	2.8
1:100 Year	0.32	0.32	15	2.4	

Roof Drain Storage Table for Area RD 4		
Elevation	Area RD 1	Total Volume
m	m ²	m ³
0.00	0	0
0.05	4.7	0.1
0.10	18.7	0.7
0.15	63.5	2.8

Stage Storage Curve: Area A-5
 Controlled Roof Drain #4

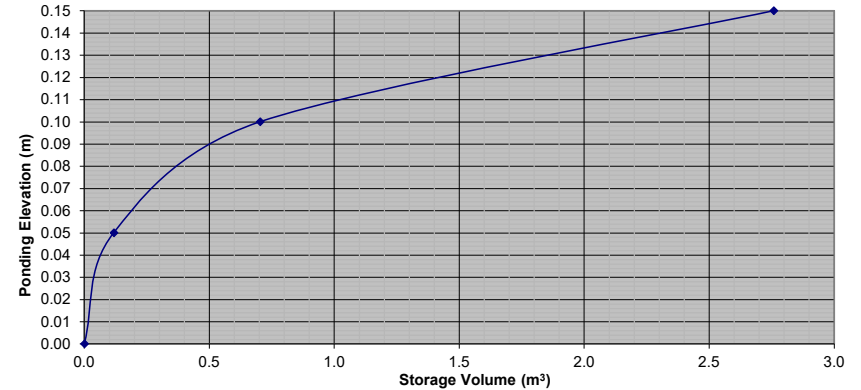

Proposed Nokia Ottawa Innovation Campus					
Novatech Project No. 123043					
REQUIRED STORAGE - 1:100 YEAR EVENT					
AREA A-5		Controlled Roof Drain #4			
OTTAWA IDF CURVE					
Area =	0.006	ha	Qallow =	0.32	L/s
C =	1.00		Vol(max) =	2.4	m3
Time (min)	Intensity (mm/hr)	Q (L/s)	Qnet (L/s)	Vol (m3)	
5	242.70	4.28	3.96	1.19	
10	178.56	3.15	2.83	1.70	
15	142.89	2.52	2.20	1.98	
20	119.95	2.12	1.80	2.16	
25	103.85	1.83	1.51	2.27	
30	91.87	1.62	1.30	2.34	
35	82.58	1.46	1.14	2.39	
40	75.15	1.33	1.01	2.42	
45	69.05	1.22	0.90	2.43	
50	63.95	1.13	0.81	2.43	
55	59.62	1.05	0.73	2.42	
60	55.89	0.99	0.67	2.40	
80	44.99	0.79	0.47	2.28	
100	37.90	0.67	0.35	2.09	
120	32.89	0.58	0.26	1.88	
140	29.15	0.51	0.19	1.63	
160	26.24	0.46	0.14	1.37	
180	23.90	0.42	0.10	1.10	

Proposed Nokia Ottawa Innovation Campus					
Novatech Project No. 123043					
REQUIRED STORAGE - 1:100 YEAR + 20%					
AREA A-5		Controlled Roof Drain #4			
OTTAWA IDF CURVE					
Area =	0.006	ha	Qallow =	0.32	L/s
C =	1.00		Vol(max) =	3.1	m3
Time (min)	Intensity (mm/hr)	Q (L/s)	Qnet (L/s)	Vol (m3)	
5	291.24	5.14	4.82	1.45	
10	214.27	3.78	3.46	2.08	
15	171.47	3.03	2.71	2.44	
20	143.94	2.54	2.22	2.67	
25	124.62	2.20	1.88	2.82	
30	110.24	1.95	1.63	2.93	
35	99.09	1.75	1.43	3.00	
40	90.17	1.59	1.27	3.05	
45	82.86	1.46	1.14	3.09	
50	76.74	1.35	1.03	3.10	
55	71.55	1.26	0.94	3.11	
60	67.07	1.18	0.86	3.11	
65	63.18	1.12	0.80	3.10	
70	59.75	1.05	0.73	3.09	
75	56.71	1.00	0.68	3.06	
90	49.33	0.87	0.55	2.97	
105	43.80	0.77	0.45	2.85	
120	39.47	0.70	0.38	2.71	

Proposed Nokia Ottawa Innovation Campus					
Novatech Project No. 123043					
REQUIRED STORAGE - 1:2 YEAR EVENT					
AREA A-5		Controlled Roof Drain #5			
OTTAWA IDF CURVE					
Area =	0.008	ha	Qallow =	0.32	L/s
C =	0.90		Vol(max) =	0.8	m3
Time (min)	Intensity (mm/hr)	Q (L/s)	Qnet (L/s)	Vol (m3)	
5	103.57	1.97	1.65	0.49	
10	76.81	1.46	1.14	0.68	
15	61.77	1.17	0.85	0.77	
20	52.03	0.99	0.67	0.80	
25	45.17	0.86	0.54	0.81	
30	40.04	0.76	0.44	0.79	
35	36.06	0.69	0.37	0.77	
40	32.86	0.62	0.30	0.73	
45	30.24	0.58	0.26	0.69	
50	28.04	0.53	0.21	0.64	
55	26.17	0.50	0.18	0.59	
60	24.56	0.47	0.15	0.53	
65	23.15	0.44	0.12	0.47	
70	21.91	0.42	0.10	0.41	
75	20.81	0.40	0.08	0.34	
90	18.14	0.34	0.02	0.13	
105	16.13	0.31	-0.01	-0.08	
120	14.56	0.28	-0.04	-0.31	

Proposed Nokia Ottawa Innovation Campus					
Novatech Project No. 123043					
REQUIRED STORAGE - 1:5 YEAR EVENT					
AREA A-5		Controlled Roof Drain #5			
OTTAWA IDF CURVE					
Area =	0.008	ha	Qallow =	0.32	L/s
C =	0.90		Vol(max) =	1.3	m3
Time (min)	Intensity (mm/hr)	Q (L/s)	Qnet (L/s)	Vol (m3)	
5	141.18	2.68	2.36	0.71	
10	104.19	1.98	1.66	1.00	
15	83.56	1.59	1.27	1.14	
20	70.25	1.34	1.02	1.22	
25	60.90	1.16	0.84	1.26	
30	53.93	1.03	0.71	1.27	
35	48.52	0.92	0.60	1.27	
40	44.18	0.84	0.52	1.25	
45	40.63	0.77	0.45	1.22	
50	37.65	0.72	0.40	1.19	
55	35.12	0.67	0.35	1.15	
60	32.94	0.63	0.31	1.10	
65	31.04	0.59	0.27	1.05	
70	29.37	0.56	0.24	1.00	
75	27.89	0.53	0.21	0.95	
90	24.29	0.46	0.14	0.77	
105	21.58	0.41	0.09	0.57	
120	19.47	0.37	0.05	0.36	

Watts Accutrol Flow Control Roof Drains: RD-100-A-ADJ set to closed					
Design Event	Flow/Drain (L/s)	Total Flow (L/s)	Ponding (cm)	Storage (m ³) Required	Storage (m ³) Provided
1:2 Year	0.32	0.32	8	0.8	
1:5 Year	0.32	0.32	10	1.3	3.3
1:100 Year	0.32	0.32	15	3.1	

Roof Drain Storage Table for Area RD 5		
Elevation	Area RD 1	Total Volume
m	m ²	m ³
0.00	0	0
0.05	5.8	0.1
0.10	23.1	0.9
0.15	76.1	3.3

Stage Storage Curve: Area A-5
 Controlled Roof Drain #5

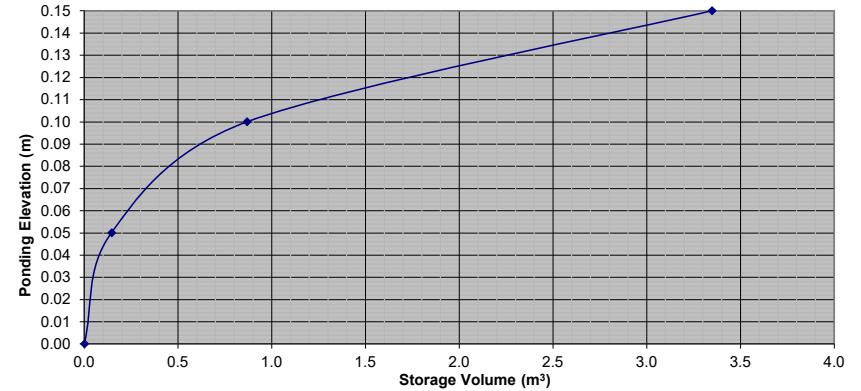

Proposed Nokia Ottawa Innovation Campus					
Novatech Project No. 123043					
REQUIRED STORAGE - 1:100 YEAR EVENT					
AREA A-5		Controlled Roof Drain #5			
OTTAWA IDF CURVE					
Area =	0.008	ha	Qallow =	0.32	L/s
C =	1.00		Vol(max) =	3.1	m3
Time (min)	Intensity (mm/hr)	Q (L/s)	Qnet (L/s)	Vol (m3)	
5	242.70	5.13	4.81	1.44	
10	178.56	3.77	3.45	2.07	
15	142.89	3.02	2.70	2.43	
20	119.95	2.53	2.21	2.66	
25	103.85	2.19	1.87	2.81	
30	91.87	1.94	1.62	2.92	
35	82.58	1.74	1.42	2.99	
40	75.15	1.59	1.27	3.04	
45	69.05	1.46	1.14	3.08	
50	63.95	1.35	1.03	3.09	
55	59.62	1.26	0.94	3.10	
60	55.89	1.18	0.86	3.10	
80	44.99	0.95	0.63	3.03	
100	37.90	0.80	0.48	2.88	
120	32.89	0.70	0.38	2.70	
140	29.15	0.62	0.30	2.49	
160	26.24	0.55	0.23	2.25	
180	23.90	0.51	0.19	2.00	

Proposed Nokia Ottawa Innovation Campus					
Novatech Project No. 123043					
REQUIRED STORAGE - 1:100 YEAR + 20%					
AREA A-5		Controlled Roof Drain #5			
OTTAWA IDF CURVE					
Area =	0.008	ha	Qallow =	0.32	L/s
C =	1.00		Vol(max) =	4.0	m3
Time (min)	Intensity (mm/hr)	Q (L/s)	Qnet (L/s)	Vol (m3)	
5	291.24	6.15	5.83	1.75	
10	214.27	4.53	4.21	2.52	
15	171.47	3.62	3.30	2.97	
20	143.94	3.04	2.72	3.27	
25	124.62	2.63	2.31	3.47	
30	110.24	2.33	2.01	3.62	
35	99.09	2.09	1.77	3.72	
40	90.17	1.91	1.59	3.80	
45	82.86	1.75	1.43	3.86	
50	76.74	1.62	1.30	3.90	
55	71.55	1.51	1.19	3.93	
60	67.07	1.42	1.10	3.95	
65	63.18	1.33	1.01	3.96	
70	59.75	1.26	0.94	3.96	
75	56.71	1.20	0.88	3.95	
90	49.33	1.04	0.72	3.90	
105	43.80	0.93	0.61	3.81	
120	39.47	0.83	0.51	3.70	

Proposed Nokia Ottawa Innovation Campus					
Novatech Project No. 123043					
REQUIRED STORAGE - 1:2 YEAR EVENT					
AREA A-5		Controlled Roof Drain #6			
OTTAWA IDF CURVE					
Area =	0.004	ha	Qallow =	0.32	L/s
C =	0.90		Vol(max) =	0.2	m3
Time (min)	Intensity (mm/hr)	Q (L/s)	Qnet (L/s)	Vol (m3)	
5	103.57	0.93	0.61	0.18	
10	76.81	0.69	0.37	0.22	
15	61.77	0.56	0.24	0.21	
20	52.03	0.47	0.15	0.18	
25	45.17	0.41	0.09	0.13	
30	40.04	0.36	0.04	0.07	
35	36.06	0.32	0.00	0.01	
40	32.86	0.30	-0.02	-0.06	
45	30.24	0.27	-0.05	-0.13	
50	28.04	0.25	-0.07	-0.20	
55	26.17	0.24	-0.08	-0.28	
60	24.56	0.22	-0.10	-0.36	
65	23.15	0.21	-0.11	-0.43	
70	21.91	0.20	-0.12	-0.52	
75	20.81	0.19	-0.13	-0.60	
90	18.14	0.16	-0.16	-0.85	
105	16.13	0.15	-0.17	-1.10	
120	14.56	0.13	-0.19	-1.36	

Proposed Nokia Ottawa Innovation Campus					
Novatech Project No. 123043					
REQUIRED STORAGE - 1:5 YEAR EVENT					
AREA A-5		Controlled Roof Drain #6			
OTTAWA IDF CURVE					
Area =	0.004	ha	Qallow =	0.32	L/s
C =	0.90		Vol(max) =	0.4	m3
Time (min)	Intensity (mm/hr)	Q (L/s)	Qnet (L/s)	Vol (m3)	
5	141.18	1.27	0.95	0.29	
10	104.19	0.94	0.62	0.37	
15	83.56	0.75	0.43	0.39	
20	70.25	0.63	0.31	0.38	
25	60.90	0.55	0.23	0.34	
30	53.93	0.49	0.17	0.30	
35	48.52	0.44	0.12	0.25	
40	44.18	0.40	0.08	0.19	
45	40.63	0.37	0.05	0.12	
50	37.65	0.34	0.02	0.06	
55	35.12	0.32	0.00	-0.01	
60	32.94	0.30	-0.02	-0.08	
65	31.04	0.28	-0.04	-0.16	
70	29.37	0.26	-0.06	-0.23	
75	27.89	0.25	-0.07	-0.31	
90	24.29	0.22	-0.10	-0.55	
105	21.58	0.19	-0.13	-0.79	
120	19.47	0.18	-0.14	-1.04	

Watts Accutrol Flow Control Roof Drains: RD-100-A-ADJ set to closed					
Design Event	Flow/Drain (L/s)	Total Flow (L/s)	Ponding (cm)	Storage (m ³) Required	Storage (m ³) Provided
1:2 Year	0.32	0.32	8	0.2	
1:5 Year	0.32	0.32	10	0.4	1.5
1:100 Year	0.32	0.32	15	1.1	

Roof Drain Storage Table for Area RD 6		
Elevation	Area RD 1	Total Volume
m	m ²	m ³
0.00	0	0
0.05	2.2	0.1
0.10	10.1	0.4
0.15	36.4	1.5

Stage Storage Curve: Area A-5
 Controlled Roof Drain #6

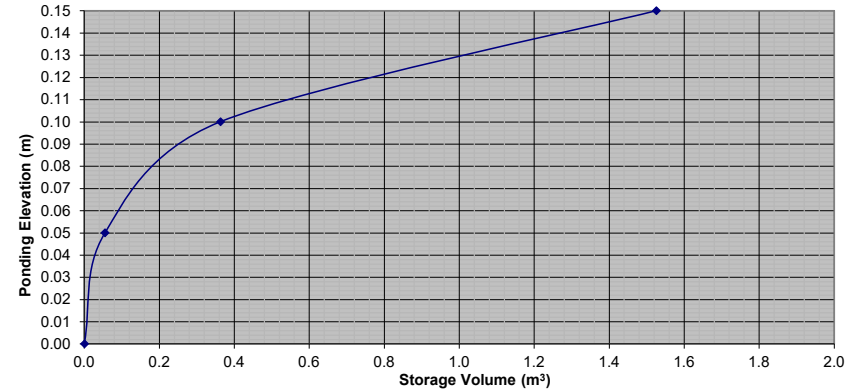

Proposed Nokia Ottawa Innovation Campus					
Novatech Project No. 123043					
REQUIRED STORAGE - 1:100 YEAR EVENT					
AREA A-5		Controlled Roof Drain #6			
OTTAWA IDF CURVE					
Area =	0.004	ha	Qallow =	0.32	L/s
C =	1.00		Vol(max) =	1.1	m3
Time (min)	Intensity (mm/hr)	Q (L/s)	Qnet (L/s)	Vol (m3)	
5	242.70	2.43	2.11	0.63	
10	178.56	1.79	1.47	0.88	
15	142.89	1.43	1.11	1.00	
20	119.95	1.20	0.88	1.06	
25	103.85	1.04	0.72	1.08	
30	91.87	0.92	0.60	1.08	
35	82.58	0.83	0.51	1.06	
40	75.15	0.75	0.43	1.04	
45	69.05	0.69	0.37	1.00	
50	63.95	0.64	0.32	0.96	
55	59.62	0.60	0.28	0.91	
60	55.89	0.56	0.24	0.86	
80	44.99	0.45	0.13	0.63	
100	37.90	0.38	0.06	0.36	
120	32.89	0.33	0.01	0.07	
140	29.15	0.29	-0.03	-0.24	
160	26.24	0.26	-0.06	-0.55	
180	23.90	0.24	-0.08	-0.87	

Proposed Nokia Ottawa Innovation Campus					
Novatech Project No. 123043					
REQUIRED STORAGE - 1:100 YEAR + 20%					
AREA A-5		Controlled Roof Drain #6			
OTTAWA IDF CURVE					
Area =	0.004	ha	Qallow =	0.32	L/s
C =	1.00		Vol(max) =	1.4	m3
Time (min)	Intensity (mm/hr)	Q (L/s)	Qnet (L/s)	Vol (m3)	
5	291.24	2.91	2.59	0.78	
10	214.27	2.14	1.82	1.09	
15	171.47	1.72	1.40	1.26	
20	143.94	1.44	1.12	1.34	
25	124.62	1.25	0.93	1.39	
30	110.24	1.10	0.78	1.41	
35	99.09	0.99	0.67	1.41	
40	90.17	0.90	0.58	1.40	
45	82.86	0.83	0.51	1.38	
50	76.74	0.77	0.45	1.34	
55	71.55	0.72	0.40	1.31	
60	67.07	0.67	0.35	1.26	
65	63.18	0.63	0.31	1.22	
70	59.75	0.60	0.28	1.17	
75	56.71	0.57	0.25	1.11	
90	49.33	0.49	0.17	0.94	
105	43.80	0.44	0.12	0.75	
120	39.47	0.40	0.08	0.54	

Proposed Nokia Ottawa Innovation Campus					
Novatech Project No. 123043					
REQUIRED STORAGE - 1:2 YEAR EVENT					
AREA A-5		Controlled Roof Drain #7			
OTTAWA IDF CURVE					
Area =	0.012	ha	Qallow =	0.32	L/s
C =	0.90		Vol(max) =	1.5	m3
Time (min)	Intensity (mm/hr)	Q (L/s)	Qnet (L/s)	Vol (m3)	
5	103.57	3.01	2.69	0.81	
10	76.81	2.23	1.91	1.15	
15	61.77	1.79	1.47	1.33	
20	52.03	1.51	1.19	1.43	
25	45.17	1.31	0.99	1.49	
30	40.04	1.16	0.84	1.52	
35	36.06	1.05	0.73	1.53	
40	32.86	0.95	0.63	1.52	
45	30.24	0.88	0.56	1.51	
50	28.04	0.81	0.49	1.48	
55	26.17	0.76	0.44	1.45	
60	24.56	0.71	0.39	1.41	
65	23.15	0.67	0.35	1.37	
70	21.91	0.64	0.32	1.33	
75	20.81	0.60	0.28	1.28	
90	18.14	0.53	0.21	1.12	
105	16.13	0.47	0.15	0.93	
120	14.56	0.42	0.10	0.74	

Proposed Nokia Ottawa Innovation Campus					
Novatech Project No. 123043					
REQUIRED STORAGE - 1:5 YEAR EVENT					
AREA A-5		Controlled Roof Drain #7			
OTTAWA IDF CURVE					
Area =	0.012	ha	Qallow =	0.32	L/s
C =	0.90		Vol(max) =	2.3	m3
Time (min)	Intensity (mm/hr)	Q (L/s)	Qnet (L/s)	Vol (m3)	
5	141.18	4.10	3.78	1.13	
10	104.19	3.02	2.70	1.62	
15	83.56	2.43	2.11	1.89	
20	70.25	2.04	1.72	2.06	
25	60.90	1.77	1.45	2.17	
30	53.93	1.57	1.25	2.24	
35	48.52	1.41	1.09	2.29	
40	44.18	1.28	0.96	2.31	
45	40.63	1.18	0.86	2.32	
50	37.65	1.09	0.77	2.32	
55	35.12	1.02	0.70	2.31	
60	32.94	0.96	0.64	2.29	
65	31.04	0.90	0.58	2.27	
70	29.37	0.85	0.53	2.24	
75	27.89	0.81	0.49	2.20	
90	24.29	0.70	0.38	2.08	
105	21.58	0.63	0.31	1.93	
120	19.47	0.57	0.25	1.76	

Watts Accutrol Flow Control Roof Drains: RD-100-A-ADJ set to closed					
Design Event	Flow/Drain (L/s)	Total Flow (L/s)	Ponding (cm)	Storage Required (m ³)	Storage Provided (m ³)
1:2 Year	0.32	0.32	8	1.5	
1:5 Year	0.32	0.32	10	2.3	5.7
1:100 Year	0.32	0.32	15	5.4	

Roof Drain Storage Table for Area RD 7		
Elevation	Area RD 1	Total Volume
m	m ²	m ³
0.00	0	0
0.05	11.9	0.3
0.10	47.7	1.8
0.15	108.6	5.7

Stage Storage Curve: Area A-5
 Controlled Roof Drain #7

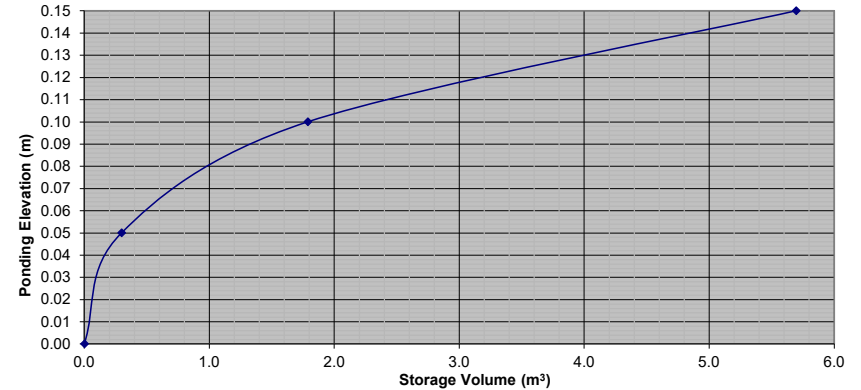

Proposed Nokia Ottawa Innovation Campus					
Novatech Project No. 123043					
REQUIRED STORAGE - 1:100 YEAR EVENT					
AREA A-5		Controlled Roof Drain #7			
OTTAWA IDF CURVE					
Area =	0.012	ha	Qallow =	0.32	L/s
C =	1.00		Vol(max) =	5.4	m3
Time (min)	Intensity (mm/hr)	Q (L/s)	Qnet (L/s)	Vol (m3)	
5	242.70	7.83	7.51	2.25	
10	178.56	5.76	5.44	3.26	
15	142.89	4.61	4.29	3.86	
20	119.95	3.87	3.55	4.26	
25	103.85	3.35	3.03	4.54	
30	91.87	2.96	2.64	4.76	
35	82.58	2.66	2.34	4.92	
40	75.15	2.42	2.10	5.05	
45	69.05	2.23	1.91	5.15	
50	63.95	2.06	1.74	5.23	
55	59.62	1.92	1.60	5.29	
60	55.89	1.80	1.48	5.34	
80	44.99	1.45	1.13	5.43	
100	37.90	1.22	0.90	5.41	
120	32.89	1.06	0.74	5.33	
140	29.15	0.94	0.62	5.21	
160	26.24	0.85	0.53	5.05	
180	23.90	0.77	0.45	4.87	

Proposed Nokia Ottawa Innovation Campus					
Novatech Project No. 123043					
REQUIRED STORAGE - 1:100 YEAR + 20%					
AREA A-5		Controlled Roof Drain #7			
OTTAWA IDF CURVE					
Area =	0.012	ha	Qallow =	0.32	L/s
C =	1.00		Vol(max) =	6.9	m3
Time (min)	Intensity (mm/hr)	Q (L/s)	Qnet (L/s)	Vol (m3)	
5	291.24	9.39	9.07	2.72	
10	214.27	6.91	6.59	3.95	
15	171.47	5.53	5.21	4.69	
20	143.94	4.64	4.32	5.19	
25	124.62	4.02	3.70	5.55	
30	110.24	3.56	3.24	5.82	
35	99.09	3.20	2.88	6.04	
40	90.17	2.91	2.59	6.21	
45	82.86	2.67	2.35	6.35	
50	76.74	2.47	2.15	6.46	
55	71.55	2.31	1.99	6.56	
60	67.07	2.16	1.84	6.63	
65	63.18	2.04	1.72	6.70	
70	59.75	1.93	1.61	6.75	
75	56.71	1.83	1.51	6.79	
90	49.33	1.59	1.27	6.86	
105	43.80	1.41	1.09	6.88	
120	39.47	1.27	0.95	6.86	

Proposed Nokia Ottawa Innovation Campus					
Novatech Project No. 123043					
REQUIRED STORAGE - 1:2 YEAR EVENT					
AREA A-5		Controlled Roof Drain #8			
OTTAWA IDF CURVE					
Area =	0.012	ha	Qallow =	0.32	L/s
C =	0.90		Vol(max) =	1.6	m3
Time (min)	Intensity (mm/hr)	Q (L/s)	Qnet (L/s)	Vol (m3)	
5	103.57	3.08	2.76	0.83	
10	76.81	2.29	1.97	1.18	
15	61.77	1.84	1.52	1.37	
20	52.03	1.55	1.23	1.48	
25	45.17	1.34	1.02	1.54	
30	40.04	1.19	0.87	1.57	
35	36.06	1.07	0.75	1.58	
40	32.86	0.98	0.66	1.58	
45	30.24	0.90	0.58	1.57	
50	28.04	0.83	0.51	1.54	
55	26.17	0.78	0.46	1.52	
60	24.56	0.73	0.41	1.48	
65	23.15	0.69	0.37	1.44	
70	21.91	0.65	0.33	1.40	
75	20.81	0.62	0.30	1.35	
90	18.14	0.54	0.22	1.19	
105	16.13	0.48	0.16	1.01	
120	14.56	0.43	0.11	0.82	

Proposed Nokia Ottawa Innovation Campus					
Novatech Project No. 123043					
REQUIRED STORAGE - 1:5 YEAR EVENT					
AREA A-5		Controlled Roof Drain #8			
OTTAWA IDF CURVE					
Area =	0.012	ha	Qallow =	0.32	L/s
C =	0.90		Vol(max) =	2.4	m3
Time (min)	Intensity (mm/hr)	Q (L/s)	Qnet (L/s)	Vol (m3)	
5	141.18	4.20	3.88	1.17	
10	104.19	3.10	2.78	1.67	
15	83.56	2.49	2.17	1.95	
20	70.25	2.09	1.77	2.13	
25	60.90	1.81	1.49	2.24	
30	53.93	1.61	1.29	2.31	
35	48.52	1.44	1.12	2.36	
40	44.18	1.32	1.00	2.39	
45	40.63	1.21	0.89	2.40	
50	37.65	1.12	0.80	2.40	
55	35.12	1.05	0.73	2.39	
60	32.94	0.98	0.66	2.38	
65	31.04	0.92	0.60	2.36	
70	29.37	0.87	0.55	2.33	
75	27.89	0.83	0.51	2.30	
90	24.29	0.72	0.40	2.18	
105	21.58	0.64	0.32	2.03	
120	19.47	0.58	0.26	1.87	

Watts Accutrol Flow Control Roof Drains: RD-100-A-ADJ set to closed					
Design Event	Flow/Drain (L/s)	Total Flow (L/s)	Ponding (cm)	Storage Required (m ³)	Storage Provided (m ³)
1:2 Year	0.32	0.32	8	1.6	
1:5 Year	0.32	0.32	10	2.4	5.8
1:100 Year	0.32	0.32	15	5.6	

Roof Drain Storage Table for Area RD 8		
Elevation	Area RD 1	Total Volume
m	m ²	m ³
0.00	0	0
0.05	11.9	0.3
0.10	47.7	1.8
0.15	111.1	5.8

Stage Storage Curve: Area A-5
 Controlled Roof Drain #8

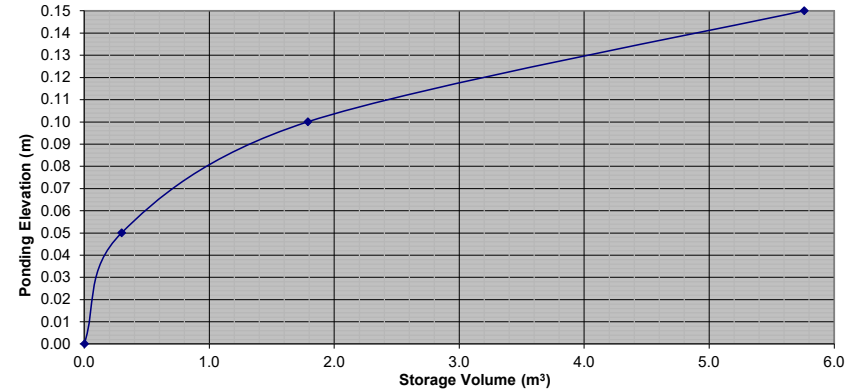

Proposed Nokia Ottawa Innovation Campus					
Novatech Project No. 123043					
REQUIRED STORAGE - 1:100 YEAR EVENT					
AREA A-5		Controlled Roof Drain #8			
OTTAWA IDF CURVE					
Area =	0.012	ha	Qallow =	0.32	L/s
C =	1.00		Vol(max) =	5.6	m3
Time (min)	Intensity (mm/hr)	Q (L/s)	Qnet (L/s)	Vol (m3)	
5	242.70	8.03	7.71	2.31	
10	178.56	5.91	5.59	3.35	
15	142.89	4.73	4.41	3.97	
20	119.95	3.97	3.65	4.38	
25	103.85	3.44	3.12	4.67	
30	91.87	3.04	2.72	4.89	
35	82.58	2.73	2.41	5.06	
40	75.15	2.49	2.17	5.20	
45	69.05	2.28	1.96	5.30	
50	63.95	2.12	1.80	5.39	
55	59.62	1.97	1.65	5.45	
60	55.89	1.85	1.53	5.50	
80	44.99	1.49	1.17	5.61	
100	37.90	1.25	0.93	5.60	
120	32.89	1.09	0.77	5.53	
140	29.15	0.96	0.64	5.41	
160	26.24	0.87	0.55	5.26	
180	23.90	0.79	0.47	5.08	

Proposed Nokia Ottawa Innovation Campus					
Novatech Project No. 123043					
REQUIRED STORAGE - 1:100 YEAR + 20%					
AREA A-5		Controlled Roof Drain #8			
OTTAWA IDF CURVE					
Area =	0.012	ha	Qallow =	0.32	L/s
C =	1.00		Vol(max) =	7.1	m3
Time (min)	Intensity (mm/hr)	Q (L/s)	Qnet (L/s)	Vol (m3)	
5	291.24	9.63	9.31	2.79	
10	214.27	7.09	6.77	4.06	
15	171.47	5.67	5.35	4.82	
20	143.94	4.76	4.44	5.33	
25	124.62	4.12	3.80	5.70	
30	110.24	3.65	3.33	5.99	
35	99.09	3.28	2.96	6.21	
40	90.17	2.98	2.66	6.39	
45	82.86	2.74	2.42	6.54	
50	76.74	2.54	2.22	6.66	
55	71.55	2.37	2.05	6.75	
60	67.07	2.22	1.90	6.84	
65	63.18	2.09	1.77	6.90	
70	59.75	1.98	1.66	6.96	
75	56.71	1.88	1.56	7.00	
90	49.33	1.63	1.31	7.09	
105	43.80	1.45	1.13	7.11	
120	39.47	1.31	0.99	7.10	

Proposed Nokia Ottawa Innovation Campus					
Novatech Project No. 123043					
REQUIRED STORAGE - 1:2 YEAR EVENT					
AREA A-5		Controlled Roof Drain #9			
OTTAWA IDF CURVE					
Area =	0.011	ha	Qallow =	0.32	L/s
C =	0.90		Vol(max) =	1.3	m3
Time (min)	Intensity (mm/hr)	Q (L/s)	Qnet (L/s)	Vol (m3)	
5	103.57	2.72	2.40	0.72	
10	76.81	2.02	1.70	1.02	
15	61.77	1.62	1.30	1.17	
20	52.03	1.37	1.05	1.26	
25	45.17	1.19	0.87	1.30	
30	40.04	1.05	0.73	1.32	
35	36.06	0.95	0.63	1.32	
40	32.86	0.86	0.54	1.30	
45	30.24	0.79	0.47	1.28	
50	28.04	0.74	0.42	1.25	
55	26.17	0.69	0.37	1.21	
60	24.56	0.65	0.33	1.17	
65	23.15	0.61	0.29	1.12	
70	21.91	0.58	0.26	1.07	
75	20.81	0.55	0.23	1.02	
90	18.14	0.48	0.16	0.85	
105	16.13	0.42	0.10	0.65	
120	14.56	0.38	0.06	0.45	

Proposed Nokia Ottawa Innovation Campus					
Novatech Project No. 123043					
REQUIRED STORAGE - 1:5 YEAR EVENT					
AREA A-5		Controlled Roof Drain #9			
OTTAWA IDF CURVE					
Area =	0.011	ha	Qallow =	0.32	L/s
C =	0.90		Vol(max) =	2.0	m3
Time (min)	Intensity (mm/hr)	Q (L/s)	Qnet (L/s)	Vol (m3)	
5	141.18	3.71	3.39	1.02	
10	104.19	2.74	2.42	1.45	
15	83.56	2.20	1.88	1.69	
20	70.25	1.85	1.53	1.83	
25	60.90	1.60	1.28	1.92	
30	53.93	1.42	1.10	1.97	
35	48.52	1.27	0.95	2.00	
40	44.18	1.16	0.84	2.02	
45	40.63	1.07	0.75	2.02	
50	37.65	0.99	0.67	2.01	
55	35.12	0.92	0.60	1.99	
60	32.94	0.87	0.55	1.96	
65	31.04	0.82	0.50	1.93	
70	29.37	0.77	0.45	1.90	
75	27.89	0.73	0.41	1.86	
90	24.29	0.64	0.32	1.72	
105	21.58	0.57	0.25	1.56	
120	19.47	0.51	0.19	1.38	

Watts Accutrol Flow Control Roof Drains: RD-100-A-ADJ set to closed					
Design Event	Flow/Drain (L/s)	Total Flow (L/s)	Ponding (cm)	Storage Required (m ³)	Storage Provided (m ³)
1:2 Year	0.32	0.32	8	1.3	
1:5 Year	0.32	0.32	10	2.0	5.0
1:100 Year	0.32	0.32	14	4.8	

Roof Drain Storage Table for Area RD 9		
Elevation	Area RD 1	Total Volume
m	m ²	m ³
0.00	0	0
0.05	9.9	0.2
0.10	42.2	1.6
0.15	95.1	5.0

Stage Storage Curve: Area A-5
 Controlled Roof Drain #9

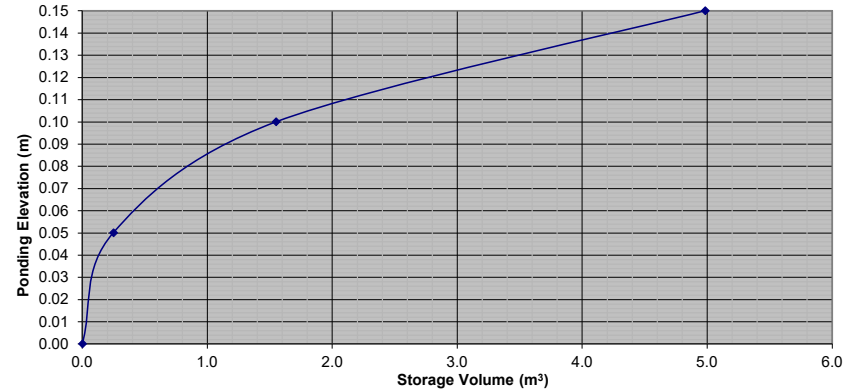

Proposed Nokia Ottawa Innovation Campus					
Novatech Project No. 123043					
REQUIRED STORAGE - 1:100 YEAR EVENT					
AREA A-5		Controlled Roof Drain #9			
OTTAWA IDF CURVE					
Area =	0.011	ha	Qallow =	0.32	L/s
C =	1.00		Vol(max) =	4.8	m3
Time (min)	Intensity (mm/hr)	Q (L/s)	Qnet (L/s)	Vol (m3)	
5	242.70	7.08	6.76	2.03	
10	178.56	5.21	4.89	2.94	
15	142.89	4.17	3.85	3.47	
20	119.95	3.50	3.18	3.82	
25	103.85	3.03	2.71	4.07	
30	91.87	2.68	2.36	4.25	
35	82.58	2.41	2.09	4.39	
40	75.15	2.19	1.87	4.50	
45	69.05	2.02	1.70	4.58	
50	63.95	1.87	1.55	4.64	
55	59.62	1.74	1.42	4.69	
60	55.89	1.63	1.31	4.72	
80	44.99	1.31	0.99	4.77	
100	37.90	1.11	0.79	4.72	
120	32.89	0.96	0.64	4.61	
140	29.15	0.85	0.53	4.46	
160	26.24	0.77	0.45	4.28	
180	23.90	0.70	0.38	4.08	

Proposed Nokia Ottawa Innovation Campus					
Novatech Project No. 123043					
REQUIRED STORAGE - 1:100 YEAR + 20%					
AREA A-5		Controlled Roof Drain #9			
OTTAWA IDF CURVE					
Area =	0.011	ha	Qallow =	0.32	L/s
C =	1.00		Vol(max) =	6.0	m3
Time (min)	Intensity (mm/hr)	Q (L/s)	Qnet (L/s)	Vol (m3)	
5	291.24	8.50	8.18	2.45	
10	214.27	6.25	5.93	3.56	
15	171.47	5.01	4.69	4.22	
20	143.94	4.20	3.88	4.66	
25	124.62	3.64	3.32	4.98	
30	110.24	3.22	2.90	5.22	
35	99.09	2.89	2.57	5.40	
40	90.17	2.63	2.31	5.55	
45	82.86	2.42	2.10	5.67	
50	76.74	2.24	1.92	5.76	
55	71.55	2.09	1.77	5.84	
60	67.07	1.96	1.64	5.90	
65	63.18	1.84	1.52	5.94	
70	59.75	1.74	1.42	5.98	
75	56.71	1.66	1.34	6.01	
90	49.33	1.44	1.12	6.05	
105	43.80	1.28	0.96	6.04	
120	39.47	1.15	0.83	5.99	

Proposed Nokia Ottawa Innovation Campus					
Novatech Project No. 123043					
REQUIRED STORAGE - 1:2 YEAR EVENT					
AREA A-5 Controlled Roof Drain #10					
OTTAWA IDF CURVE					
Area =	0.011	ha	Qallow =	0.32	L/s
C =	0.90		Vol(max) =	1.4	m ³
Time (min)	Intensity (mm/hr)	Q (L/s)	Qnet (L/s)	Vol (m ³)	
5	103.57	2.82	2.50	0.75	
10	76.81	2.09	1.77	1.06	
15	61.77	1.68	1.36	1.23	
20	52.03	1.42	1.10	1.32	
25	45.17	1.23	0.91	1.37	
30	40.04	1.09	0.77	1.39	
35	36.06	0.98	0.66	1.39	
40	32.86	0.90	0.58	1.38	
45	30.24	0.82	0.50	1.36	
50	28.04	0.76	0.44	1.33	
55	26.17	0.71	0.39	1.30	
60	24.56	0.67	0.35	1.26	
65	23.15	0.63	0.31	1.21	
70	21.91	0.60	0.28	1.17	
75	20.81	0.57	0.25	1.11	
90	18.14	0.49	0.17	0.94	
105	16.13	0.44	0.12	0.76	
120	14.56	0.40	0.08	0.56	

Proposed Nokia Ottawa Innovation Campus					
Novatech Project No. 123043					
REQUIRED STORAGE - 1:5 YEAR EVENT					
AREA A-5 Controlled Roof Drain #10					
OTTAWA IDF CURVE					
Area =	0.011	ha	Qallow =	0.32	L/s
C =	0.90		Vol(max) =	2.1	m ³
Time (min)	Intensity (mm/hr)	Q (L/s)	Qnet (L/s)	Vol (m ³)	
5	141.18	3.85	3.53	1.06	
10	104.19	2.84	2.52	1.51	
15	83.56	2.28	1.96	1.76	
20	70.25	1.92	1.60	1.92	
25	60.90	1.66	1.34	2.01	
30	53.93	1.47	1.15	2.07	
35	48.52	1.32	1.00	2.11	
40	44.18	1.20	0.88	2.12	
45	40.63	1.11	0.79	2.13	
50	37.65	1.03	0.71	2.12	
55	35.12	0.96	0.64	2.10	
60	32.94	0.90	0.58	2.08	
65	31.04	0.85	0.53	2.05	
70	29.37	0.80	0.48	2.02	
75	27.89	0.76	0.44	1.98	
90	24.29	0.66	0.34	1.85	
105	21.58	0.59	0.27	1.69	
120	19.47	0.53	0.21	1.52	

Watts Accutrol Flow Control Roof Drains: RD-100-A-ADJ set to closed					
Design Event	Flow/Drain (L/s)	Total Flow (L/s)	Ponding (cm)	Storage (m ³)	
				Required	Provided
1:2 Year	0.32	0.32	8	1.4	
1:5 Year	0.32	0.32	10	2.1	5.0
1:100 Year	0.32	0.32	14	5.0	

Roof Drain Storage Table for Area RD 10		
Elevation	Area RD 1	Total Volume
m	m ²	m ³
0.00	0	0
0.05	9.9	0.2
0.10	42.2	1.6
0.15	95.1	5.0

Proposed Nokia Ottawa Innovation Campus					
Novatech Project No. 123043					
REQUIRED STORAGE - 1:100 YEAR EVENT					
AREA A-5 Controlled Roof Drain #10					
OTTAWA IDF CURVE					
Area =	0.011	ha	Qallow =	0.32	L/s
C =	1.00		Vol(max) =	5.0	m ³
Time (min)	Intensity (mm/hr)	Q (L/s)	Qnet (L/s)	Vol (m ³)	
5	242.70	7.35	7.03	2.11	
10	178.56	5.41	5.09	3.05	
15	142.89	4.33	4.01	3.61	
20	119.95	3.63	3.31	3.98	
25	103.85	3.15	2.83	4.24	
30	91.87	2.78	2.46	4.43	
35	82.58	2.50	2.18	4.58	
40	75.15	2.28	1.96	4.70	
45	69.05	2.09	1.77	4.79	
50	63.95	1.94	1.62	4.85	
55	59.62	1.81	1.49	4.91	
60	55.89	1.69	1.37	4.95	
80	44.99	1.36	1.04	5.01	
100	37.90	1.15	0.83	4.97	
120	32.89	1.00	0.68	4.87	
140	29.15	0.88	0.56	4.73	
160	26.24	0.80	0.48	4.56	
180	23.90	0.72	0.40	4.37	

Proposed Nokia Ottawa Innovation Campus					
Novatech Project No. 123043					
REQUIRED STORAGE - 1:100 YEAR + 20%					
AREA A-5 Controlled Roof Drain #10					
OTTAWA IDF CURVE					
Area =	0.011	ha	Qallow =	0.32	L/s
C =	1.00		Vol(max) =	6.3	m ³
Time (min)	Intensity (mm/hr)	Q (L/s)	Qnet (L/s)	Vol (m ³)	
5	291.24	8.83	8.51	2.55	
10	214.27	6.49	6.17	3.70	
15	171.47	5.20	4.88	4.39	
20	143.94	4.36	4.04	4.85	
25	124.62	3.78	3.46	5.18	
30	110.24	3.34	3.02	5.44	
35	99.09	3.00	2.68	5.63	
40	90.17	2.73	2.41	5.79	
45	82.86	2.51	2.19	5.92	
50	76.74	2.33	2.01	6.02	
55	71.55	2.17	1.85	6.10	
60	67.07	2.03	1.71	6.16	
65	63.18	1.91	1.59	6.22	
70	59.75	1.81	1.49	6.26	
75	56.71	1.72	1.40	6.29	
90	49.33	1.49	1.17	6.34	
105	43.80	1.33	1.01	6.34	
120	39.47	1.20	0.88	6.31	

Stage Storage Curve: Area A-5
 Controlled Roof Drain #10

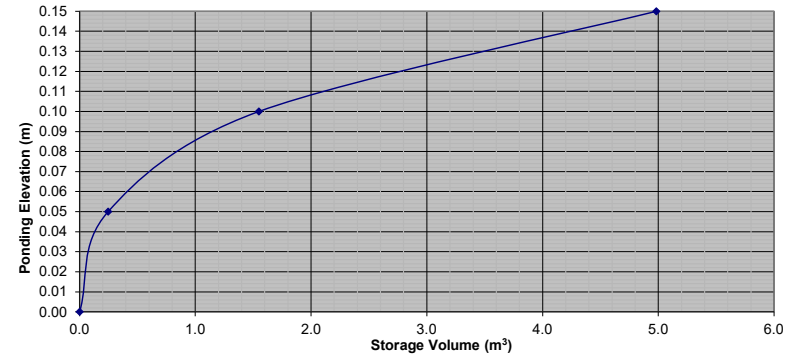

Proposed Nokia Ottawa Innovation Campus					
Novatech Project No. 123043					
REQUIRED STORAGE - 1:2 YEAR EVENT					
AREA A-5		Controlled Roof Drain #11			
OTTAWA IDF CURVE					
Area =	0.020	ha	Qallow =	0.71	L/s
C =	0.90		Vol(max) =	2.3	m3
Time (min)	Intensity (mm/hr)	Q (L/s)	Qnet (L/s)	Vol (m3)	
5	103.57	5.16	4.45	1.33	
10	76.81	3.82	3.11	1.87	
15	61.77	3.08	2.37	2.13	
20	52.03	2.59	1.88	2.26	
25	45.17	2.25	1.54	2.31	
30	40.04	1.99	1.28	2.31	
35	36.06	1.80	1.09	2.28	
40	32.86	1.64	0.93	2.22	
45	30.24	1.51	0.80	2.15	
50	28.04	1.40	0.69	2.06	
55	26.17	1.30	0.59	1.96	
60	24.56	1.22	0.51	1.85	
65	23.15	1.15	0.44	1.73	
70	21.91	1.09	0.38	1.60	
75	20.81	1.04	0.33	1.47	
90	18.14	0.90	0.19	1.04	
105	16.13	0.80	0.09	0.59	
120	14.56	0.73	0.02	0.11	

Proposed Nokia Ottawa Innovation Campus					
Novatech Project No. 123043					
REQUIRED STORAGE - 1:5 YEAR EVENT					
AREA A-5		Controlled Roof Drain #11			
OTTAWA IDF CURVE					
Area =	0.020	ha	Qallow =	0.79	L/s
C =	0.90		Vol(max) =	3.4	m3
Time (min)	Intensity (mm/hr)	Q (L/s)	Qnet (L/s)	Vol (m3)	
5	141.18	7.03	6.24	1.87	
10	104.19	5.19	4.40	2.64	
15	83.56	4.16	3.37	3.03	
20	70.25	3.50	2.71	3.25	
25	60.90	3.03	2.24	3.36	
30	53.93	2.69	1.90	3.41	
35	48.52	2.42	1.63	3.41	
40	44.18	2.20	1.41	3.38	
45	40.63	2.02	1.23	3.33	
50	37.65	1.87	1.08	3.25	
55	35.12	1.75	0.96	3.16	
60	32.94	1.64	0.85	3.06	
65	31.04	1.55	0.76	2.95	
70	29.37	1.46	0.67	2.82	
75	27.89	1.39	0.60	2.69	
90	24.29	1.21	0.42	2.26	
105	21.58	1.07	0.28	1.79	
120	19.47	0.97	0.18	1.29	

Watts Accutrol Flow Control Roof Drains: RD-100-A-ADJ set to 1/4 open					
Design Event	Flow/Drain (L/s)	Total Flow (L/s)	Ponding (cm)	Storage (m ³)	
				Required	Provided
1:2 Year	0.71	0.71	8	2.3	
1:5 Year	0.79	0.79	10	3.4	8.7
1:100 Year	0.95	0.95	15	7.8	

Roof Drain Storage Table for Area RD 11		
Elevation	Area RD 1	Total Volume
m	m ²	m ³
0.00	0	0
0.05	16.5	0.4
0.10	73.5	2.7
0.15	166.3	8.7

Stage Storage Curve: Area A-5
 Controlled Roof Drain #11

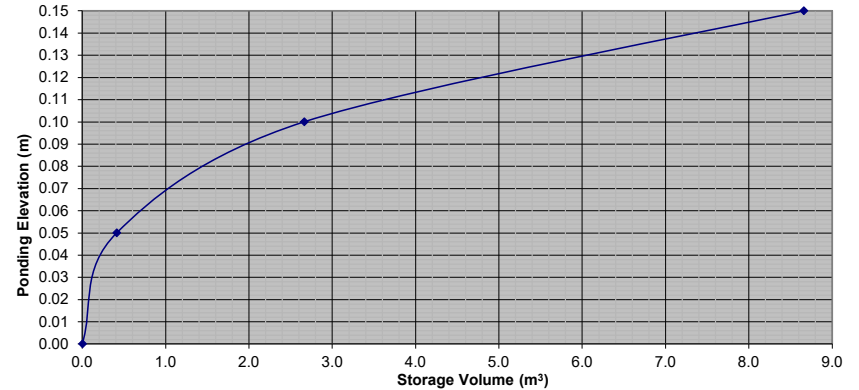

Proposed Nokia Ottawa Innovation Campus					
Novatech Project No. 123043					
REQUIRED STORAGE - 1:100 YEAR EVENT					
AREA A-5		Controlled Roof Drain #11			
OTTAWA IDF CURVE					
Area =	0.020	ha	Qallow =	0.95	L/s
C =	1.00		Vol(max) =	7.8	m3
Time (min)	Intensity (mm/hr)	Q (L/s)	Qnet (L/s)	Vol (m3)	
5	242.70	13.43	12.48	3.74	
10	178.56	9.88	8.93	5.36	
15	142.89	7.91	6.96	6.26	
20	119.95	6.64	5.69	6.82	
25	103.85	5.75	4.80	7.19	
30	91.87	5.08	4.13	7.44	
35	82.58	4.57	3.62	7.60	
40	75.15	4.16	3.21	7.70	
45	69.05	3.82	2.87	7.75	
50	63.95	3.54	2.59	7.76	
55	59.62	3.30	2.35	7.75	
60	55.89	3.09	2.14	7.71	
80	44.99	2.49	1.54	7.39	
100	37.90	2.10	1.15	6.88	
120	32.89	1.82	0.87	6.26	
140	29.15	1.61	0.66	5.57	
160	26.24	1.45	0.50	4.82	
180	23.90	1.32	0.37	4.02	

Proposed Nokia Ottawa Innovation Campus					
Novatech Project No. 123043					
REQUIRED STORAGE - 1:100 YEAR + 20%					
AREA A-5		Controlled Roof Drain #11			
OTTAWA IDF CURVE					
Area =	0.020	ha	Qallow =	0.95	L/s
C =	1.00		Vol(max) =	9.9	m3
Time (min)	Intensity (mm/hr)	Q (L/s)	Qnet (L/s)	Vol (m3)	
5	291.24	16.11	15.16	4.55	
10	214.27	11.85	10.90	6.54	
15	171.47	9.49	8.54	7.68	
20	143.94	7.96	7.01	8.42	
25	124.62	6.89	5.94	8.92	
30	110.24	6.10	5.15	9.27	
35	99.09	5.48	4.53	9.52	
40	90.17	4.99	4.04	9.69	
45	82.86	4.58	3.63	9.81	
50	76.74	4.25	3.30	9.89	
55	71.55	3.96	3.01	9.93	
60	67.07	3.71	2.76	9.94	
65	63.18	3.50	2.55	9.93	
70	59.75	3.31	2.36	9.89	
75	56.71	3.14	2.19	9.84	
90	49.33	2.73	1.78	9.61	
105	43.80	2.42	1.47	9.28	
120	39.47	2.18	1.23	8.88	

Proposed Nokia Ottawa Innovation Campus					
Novatech Project No. 123043					
REQUIRED STORAGE - 1:2 YEAR EVENT					
AREA A-5 Controlled Roof Drain #12					
OTTAWA IDF CURVE					
Area =	0.025	ha	Qallow =	0.71	L/s
C =	0.90		Vol(max) =	3.2	m3
Time (min)	Intensity (mm/hr)	Q (L/s)	Qnet (L/s)	Vol (m3)	
5	103.57	6.45	5.74	1.72	
10	76.81	4.78	4.07	2.44	
15	61.77	3.85	3.14	2.82	
20	52.03	3.24	2.53	3.04	
25	45.17	2.81	2.10	3.16	
30	40.04	2.49	1.78	3.21	
35	36.06	2.25	1.54	3.23	
40	32.86	2.05	1.34	3.21	
45	30.24	1.88	1.17	3.17	
50	28.04	1.75	1.04	3.11	
55	26.17	1.63	0.92	3.04	
60	24.56	1.53	0.82	2.95	
65	23.15	1.44	0.73	2.86	
70	21.91	1.37	0.66	2.75	
75	20.81	1.30	0.59	2.64	
90	18.14	1.13	0.42	2.27	
105	16.13	1.01	0.30	1.86	
120	14.56	0.91	0.20	1.42	

Proposed Nokia Ottawa Innovation Campus					
Novatech Project No. 123043					
REQUIRED STORAGE - 1:5 YEAR EVENT					
AREA A-5 Controlled Roof Drain #12					
OTTAWA IDF CURVE					
Area =	0.025	ha	Qallow =	0.79	L/s
C =	0.90		Vol(max) =	4.7	m3
Time (min)	Intensity (mm/hr)	Q (L/s)	Qnet (L/s)	Vol (m3)	
5	141.18	8.80	8.01	2.40	
10	104.19	6.49	5.70	3.42	
15	83.56	5.21	4.42	3.97	
20	70.25	4.38	3.59	4.30	
25	60.90	3.79	3.00	4.51	
30	53.93	3.36	2.57	4.63	
35	48.52	3.02	2.23	4.69	
40	44.18	2.75	1.96	4.71	
45	40.63	2.53	1.74	4.70	
50	37.65	2.35	1.56	4.67	
55	35.12	2.19	1.40	4.61	
60	32.94	2.05	1.26	4.54	
65	31.04	1.93	1.14	4.46	
70	29.37	1.83	1.04	4.37	
75	27.89	1.74	0.95	4.26	
90	24.29	1.51	0.72	3.91	
105	21.58	1.34	0.55	3.49	
120	19.47	1.21	0.42	3.04	

Watts Accutrol Flow Control Roof Drains: RD-100-A-ADJ set to 1/4 open					
Design Event	Flow/Drain (L/s)	Total Flow (L/s)	Ponding (cm)	Required Storage (m ³)	Provided
1:2 Year	0.71	0.71	8	3.2	
1:5 Year	0.79	0.79	10	4.7	10.9
1:100 Year	0.95	0.95	15	10.5	

Roof Drain Storage Table for Area RD 12		
Elevation	Area RD 1	Total Volume
m	m ²	m ³
0.00	0	0
0.05	20.3	0.5
0.10	93.4	3.4
0.15	207.4	10.9

Proposed Nokia Ottawa Innovation Campus					
Novatech Project No. 123043					
REQUIRED STORAGE - 1:100 YEAR EVENT					
AREA A-5 Controlled Roof Drain #12					
OTTAWA IDF CURVE					
Area =	0.025	ha	Qallow =	0.95	L/s
C =	1.00		Vol(max) =	10.5	m3
Time (min)	Intensity (mm/hr)	Q (L/s)	Qnet (L/s)	Vol (m3)	
5	242.70	16.80	15.85	4.76	
10	178.56	12.36	11.41	6.85	
15	142.89	9.89	8.94	8.05	
20	119.95	8.30	7.35	8.82	
25	103.85	7.19	6.24	9.36	
30	91.87	6.36	5.41	9.74	
35	82.58	5.72	4.77	10.01	
40	75.15	5.20	4.25	10.20	
45	69.05	4.78	3.83	10.34	
50	63.95	4.43	3.48	10.43	
55	59.62	4.13	3.18	10.49	
60	55.89	3.87	2.92	10.51	
80	44.99	3.11	2.16	10.39	
100	37.90	2.62	1.67	10.04	
120	32.89	2.28	1.33	9.55	
140	29.15	2.02	1.07	8.97	
160	26.24	1.82	0.87	8.32	
180	23.90	1.65	0.70	7.61	

Proposed Nokia Ottawa Innovation Campus					
Novatech Project No. 123043					
REQUIRED STORAGE - 1:100 YEAR + 20%					
AREA A-5 Controlled Roof Drain #12					
OTTAWA IDF CURVE					
Area =	0.025	ha	Qallow =	0.95	L/s
C =	1.00		Vol(max) =	13.4	m3
Time (min)	Intensity (mm/hr)	Q (L/s)	Qnet (L/s)	Vol (m3)	
5	291.24	20.16	19.21	5.76	
10	214.27	14.83	13.88	8.33	
15	171.47	11.87	10.92	9.83	
20	143.94	9.96	9.01	10.82	
25	124.62	8.63	7.68	11.51	
30	110.24	7.63	6.68	12.03	
35	99.09	6.86	5.91	12.41	
40	90.17	6.24	5.29	12.70	
45	82.86	5.74	4.79	12.92	
50	76.74	5.31	4.36	13.09	
55	71.55	4.95	4.00	13.21	
60	67.07	4.64	3.69	13.29	
65	63.18	4.37	3.42	13.35	
70	59.75	4.14	3.19	13.38	
75	56.71	3.93	2.98	13.39	
90	49.33	3.41	2.46	13.31	
105	43.80	3.03	2.08	13.11	
120	39.47	2.73	1.78	12.83	

Stage Storage Curve: Area A-5
 Controlled Roof Drain #12

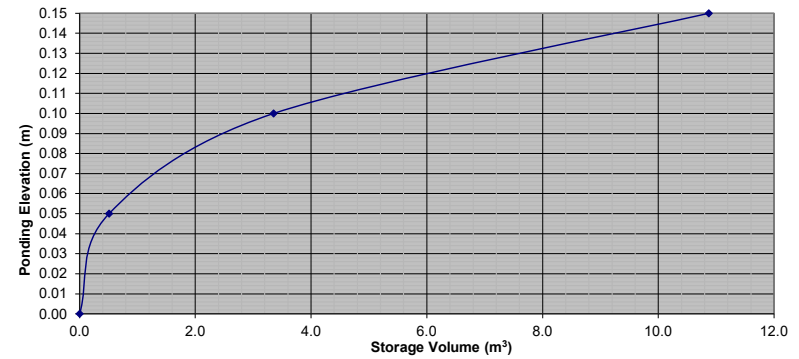

Proposed Nokia Ottawa Innovation Campus					
Novatech Project No. 123043					
REQUIRED STORAGE - 1:2 YEAR EVENT					
AREA A-5 Controlled Roof Drain #13					
OTTAWA IDF CURVE					
Area =	0.019	ha	Qallow =	0.71	L/s
C =	0.90		Vol(max) =	2.2	m3
Time (min)	Intensity (mm/hr)	Q (L/s)	Qnet (L/s)	Vol (m3)	
5	103.57	5.00	4.29	1.29	
10	76.81	3.71	3.00	1.80	
15	61.77	2.98	2.27	2.05	
20	52.03	2.51	1.80	2.16	
25	45.17	2.18	1.47	2.21	
30	40.04	1.93	1.22	2.20	
35	36.06	1.74	1.03	2.17	
40	32.86	1.59	0.88	2.10	
45	30.24	1.46	0.75	2.03	
50	28.04	1.35	0.64	1.93	
55	26.17	1.26	0.55	1.83	
60	24.56	1.19	0.48	1.71	
65	23.15	1.12	0.41	1.59	
70	21.91	1.06	0.35	1.46	
75	20.81	1.01	0.30	1.33	
90	18.14	0.88	0.17	0.90	
105	16.13	0.78	0.07	0.44	
120	14.56	0.70	-0.01	-0.05	

Proposed Nokia Ottawa Innovation Campus					
Novatech Project No. 123043					
REQUIRED STORAGE - 1:5 YEAR EVENT					
AREA A-5 Controlled Roof Drain #13					
OTTAWA IDF CURVE					
Area =	0.019	ha	Qallow =	0.79	L/s
C =	0.90		Vol(max) =	3.3	m3
Time (min)	Intensity (mm/hr)	Q (L/s)	Qnet (L/s)	Vol (m3)	
5	141.18	6.82	6.03	1.81	
10	104.19	5.03	4.24	2.54	
15	83.56	4.03	3.24	2.92	
20	70.25	3.39	2.60	3.12	
25	60.90	2.94	2.15	3.23	
30	53.93	2.60	1.81	3.27	
35	48.52	2.34	1.55	3.26	
40	44.18	2.13	1.34	3.22	
45	40.63	1.96	1.17	3.16	
50	37.65	1.82	1.03	3.08	
55	35.12	1.70	0.91	2.99	
60	32.94	1.59	0.80	2.88	
65	31.04	1.50	0.71	2.77	
70	29.37	1.42	0.63	2.64	
75	27.89	1.35	0.56	2.51	
90	24.29	1.17	0.38	2.07	
105	21.58	1.04	0.25	1.59	
120	19.47	0.94	0.15	1.08	

Watts Accutrol Flow Control Roof Drains: RD-100-A-ADJ set to 1/4 open					
Design Event	Flow/Drain (L/s)	Total Flow (L/s)	Ponding (cm)	Required Storage (m ³)	Provided
1:2 Year	0.71	0.71	8	2.2	
1:5 Year	0.79	0.79	10	3.3	8.4
1:100 Year	0.95	0.95	15	7.4	

Roof Drain Storage Table for Area RD 13		
Elevation	Area RD 1	Total Volume
m	m ²	m ³
0.00	0	0
0.05	15.9	0.4
0.10	71.9	2.6
0.15	161.7	8.4

Proposed Nokia Ottawa Innovation Campus					
Novatech Project No. 123043					
REQUIRED STORAGE - 1:100 YEAR EVENT					
AREA A-5 Controlled Roof Drain #13					
OTTAWA IDF CURVE					
Area =	0.019	ha	Qallow =	0.95	L/s
C =	1.00		Vol(max) =	7.4	m3
Time (min)	Intensity (mm/hr)	Q (L/s)	Qnet (L/s)	Vol (m3)	
5	242.70	13.02	12.07	3.62	
10	178.56	9.58	8.63	5.18	
15	142.89	7.67	6.72	6.05	
20	119.95	6.44	5.49	6.58	
25	103.85	5.57	4.62	6.93	
30	91.87	4.93	3.98	7.16	
35	82.58	4.43	3.48	7.31	
40	75.15	4.03	3.08	7.40	
45	69.05	3.70	2.75	7.44	
50	63.95	3.43	2.48	7.44	
55	59.62	3.20	2.25	7.42	
60	55.89	3.00	2.05	7.38	
80	44.99	2.41	1.46	7.03	
100	37.90	2.03	1.08	6.50	
120	32.89	1.76	0.81	5.87	
140	29.15	1.56	0.61	5.16	
160	26.24	1.41	0.46	4.40	
180	23.90	1.28	0.33	3.59	

Proposed Nokia Ottawa Innovation Campus					
Novatech Project No. 123043					
REQUIRED STORAGE - 1:100 YEAR + 20%					
AREA A-5 Controlled Roof Drain #13					
OTTAWA IDF CURVE					
Area =	0.019	ha	Qallow =	0.95	L/s
C =	1.00		Vol(max) =	9.5	m3
Time (min)	Intensity (mm/hr)	Q (L/s)	Qnet (L/s)	Vol (m3)	
5	291.24	15.63	14.68	4.40	
10	214.27	11.50	10.55	6.33	
15	171.47	9.20	8.25	7.43	
20	143.94	7.72	6.77	8.13	
25	124.62	6.69	5.74	8.60	
30	110.24	5.91	4.96	8.94	
35	99.09	5.32	4.37	9.17	
40	90.17	4.84	3.89	9.33	
45	82.86	4.45	3.50	9.44	
50	76.74	4.12	3.17	9.50	
55	71.55	3.84	2.89	9.53	
60	67.07	3.60	2.65	9.54	
65	63.18	3.39	2.44	9.51	
70	59.75	3.21	2.26	9.47	
75	56.71	3.04	2.09	9.42	
90	49.33	2.65	1.70	9.16	
105	43.80	2.35	1.40	8.82	
120	39.47	2.12	1.17	8.41	

Stage Storage Curve: Area A-5
 Controlled Roof Drain #13

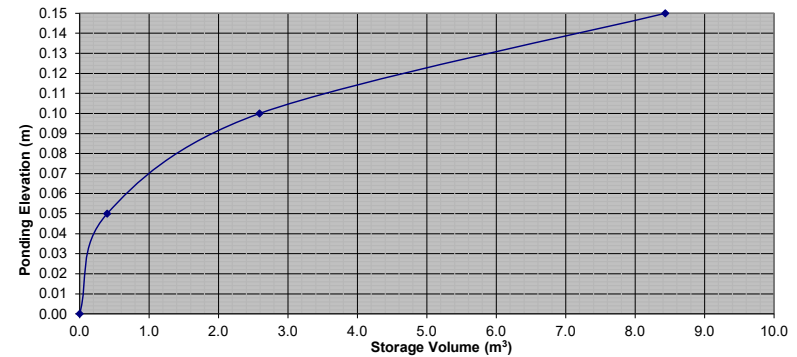

Proposed Nokia Ottawa Innovation Campus					
Novatech Project No. 123043					
REQUIRED STORAGE - 1:2 YEAR EVENT					
AREA A-5		Controlled Roof Drain #14			
OTTAWA IDF CURVE					
Area =	0.024	ha	Qallow =	0.71	L/s
C =	0.90		Vol(max) =	3.0	m3
Time (min)	Intensity (mm/hr)	Q (L/s)	Qnet (L/s)	Vol (m3)	
5	103.57	6.19	5.48	1.65	
10	76.81	4.59	3.88	2.33	
15	61.77	3.69	2.98	2.69	
20	52.03	3.11	2.40	2.88	
25	45.17	2.70	1.99	2.99	
30	40.04	2.39	1.68	3.03	
35	36.06	2.16	1.45	3.04	
40	32.86	1.97	1.26	3.01	
45	30.24	1.81	1.10	2.97	
50	28.04	1.68	0.97	2.90	
55	26.17	1.56	0.85	2.82	
60	24.56	1.47	0.76	2.73	
65	23.15	1.38	0.67	2.63	
70	21.91	1.31	0.60	2.52	
75	20.81	1.24	0.53	2.41	
90	18.14	1.08	0.37	2.02	
105	16.13	0.96	0.25	1.60	
120	14.56	0.87	0.16	1.16	

Proposed Nokia Ottawa Innovation Campus					
Novatech Project No. 123043					
REQUIRED STORAGE - 1:5 YEAR EVENT					
AREA A-5		Controlled Roof Drain #14			
OTTAWA IDF CURVE					
Area =	0.024	ha	Qallow =	0.79	L/s
C =	0.90		Vol(max) =	4.4	m3
Time (min)	Intensity (mm/hr)	Q (L/s)	Qnet (L/s)	Vol (m3)	
5	141.18	8.44	7.65	2.30	
10	104.19	6.23	5.44	3.26	
15	83.56	5.00	4.21	3.79	
20	70.25	4.20	3.41	4.09	
25	60.90	3.64	2.85	4.28	
30	53.93	3.22	2.43	4.38	
35	48.52	2.90	2.11	4.43	
40	44.18	2.64	1.85	4.45	
45	40.63	2.43	1.64	4.43	
50	37.65	2.25	1.46	4.38	
55	35.12	2.10	1.31	4.32	
60	32.94	1.97	1.18	4.25	
65	31.04	1.86	1.07	4.16	
70	29.37	1.76	0.97	4.06	
75	27.89	1.67	0.88	3.95	
90	24.29	1.45	0.66	3.58	
105	21.58	1.29	0.50	3.15	
120	19.47	1.16	0.37	2.69	

Watts Accutrol Flow Control Roof Drains: RD-100-A-ADJ set to 1/4 open					
Design Event	Flow/Drain (L/s)	Total Flow (L/s)	Ponding (cm)	Storage (m ³)	
				Required	Provided
1:2 Year	0.71	0.71	8	3.0	
1:5 Year	0.79	0.79	10	4.4	11.1
1:100 Year	0.95	0.95	15	9.9	

Roof Drain Storage Table for Area RD 14		
Elevation	Area RD 1	Total Volume
m	m ²	m ³
0.00	0	0
0.05	23.3	0.6
0.10	93.4	3.5
0.15	210.3	11.1

Stage Storage Curve: Area A-5
 Controlled Roof Drain #14

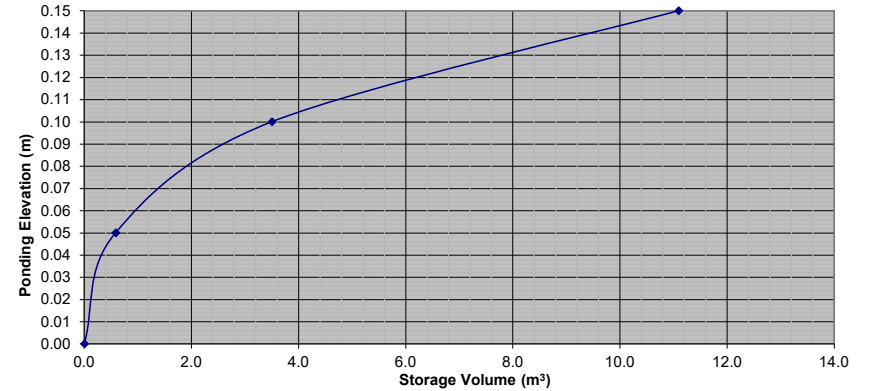

Proposed Nokia Ottawa Innovation Campus					
Novatech Project No. 123043					
REQUIRED STORAGE - 1:100 YEAR EVENT					
AREA A-5		Controlled Roof Drain #14			
OTTAWA IDF CURVE					
Area =	0.024	ha	Qallow =	0.95	L/s
C =	1.00		Vol(max) =	9.9	m3
Time (min)	Intensity (mm/hr)	Q (L/s)	Qnet (L/s)	Vol (m3)	
5	242.70	16.13	15.18	4.55	
10	178.56	11.86	10.91	6.55	
15	142.89	9.49	8.54	7.69	
20	119.95	7.97	7.02	8.42	
25	103.85	6.90	5.95	8.92	
30	91.87	6.10	5.15	9.28	
35	82.58	5.49	4.54	9.53	
40	75.15	4.99	4.04	9.70	
45	69.05	4.59	3.64	9.82	
50	63.95	4.25	3.30	9.90	
55	59.62	3.96	3.01	9.94	
60	55.89	3.71	2.76	9.95	
80	44.99	2.99	2.04	9.79	
100	37.90	2.52	1.57	9.41	
120	32.89	2.19	1.24	8.90	
140	29.15	1.94	0.99	8.29	
160	26.24	1.74	0.79	7.62	
180	23.90	1.59	0.64	6.89	

Proposed Nokia Ottawa Innovation Campus					
Novatech Project No. 123043					
REQUIRED STORAGE - 1:100 YEAR + 20%					
AREA A-5		Controlled Roof Drain #14			
OTTAWA IDF CURVE					
Area =	0.024	ha	Qallow =	0.95	L/s
C =	1.00		Vol(max) =	12.7	m3
Time (min)	Intensity (mm/hr)	Q (L/s)	Qnet (L/s)	Vol (m3)	
5	291.24	19.35	18.40	5.52	
10	214.27	14.24	13.29	7.97	
15	171.47	11.39	10.44	9.40	
20	143.94	9.56	8.61	10.34	
25	124.62	8.28	7.33	10.99	
30	110.24	7.32	6.37	11.47	
35	99.09	6.58	5.63	11.83	
40	90.17	5.99	5.04	12.10	
45	82.86	5.51	4.56	12.30	
50	76.74	5.10	4.15	12.45	
55	71.55	4.75	3.80	12.55	
60	67.07	4.46	3.51	12.62	
65	63.18	4.20	3.25	12.67	
70	59.75	3.97	3.02	12.68	
75	56.71	3.77	2.82	12.68	
90	49.33	3.28	2.33	12.57	
105	43.80	2.91	1.96	12.35	
120	39.47	2.62	1.67	12.04	

Proposed Nokia Ottawa Innovation Campus					
Novatech Project No. 123043					
REQUIRED STORAGE - 1:2 YEAR EVENT					
AREA A-5		Controlled Roof Drain #15			
OTTAWA IDF CURVE					
Area =	0.019	ha	Qallow =	0.71	L/s
C =	0.90		Vol(max) =	2.2	m3
Time (min)	Intensity (mm/hr)	Q (L/s)	Qnet (L/s)	Vol (m3)	
5	103.57	5.03	4.32	1.30	
10	76.81	3.73	3.02	1.81	
15	61.77	3.00	2.29	2.06	
20	52.03	2.53	1.82	2.18	
25	45.17	2.19	1.48	2.22	
30	40.04	1.94	1.23	2.22	
35	36.06	1.75	1.04	2.18	
40	32.86	1.60	0.89	2.12	
45	30.24	1.47	0.76	2.05	
50	28.04	1.36	0.65	1.95	
55	26.17	1.27	0.56	1.85	
60	24.56	1.19	0.48	1.74	
65	23.15	1.12	0.41	1.61	
70	21.91	1.06	0.35	1.49	
75	20.81	1.01	0.30	1.35	
90	18.14	0.88	0.17	0.92	
105	16.13	0.78	0.07	0.46	
120	14.56	0.71	0.00	-0.02	

Proposed Nokia Ottawa Innovation Campus					
Novatech Project No. 123043					
REQUIRED STORAGE - 1:5 YEAR EVENT					
AREA A-5		Controlled Roof Drain #15			
OTTAWA IDF CURVE					
Area =	0.019	ha	Qallow =	0.79	L/s
C =	0.90		Vol(max) =	3.3	m3
Time (min)	Intensity (mm/hr)	Q (L/s)	Qnet (L/s)	Vol (m3)	
5	141.18	6.85	6.06	1.82	
10	104.19	5.06	4.27	2.56	
15	83.56	4.06	3.27	2.94	
20	70.25	3.41	2.62	3.14	
25	60.90	2.96	2.17	3.25	
30	53.93	2.62	1.83	3.29	
35	48.52	2.35	1.56	3.29	
40	44.18	2.14	1.35	3.25	
45	40.63	1.97	1.18	3.19	
50	37.65	1.83	1.04	3.11	
55	35.12	1.70	0.91	3.02	
60	32.94	1.60	0.81	2.91	
65	31.04	1.51	0.72	2.80	
70	29.37	1.43	0.64	2.67	
75	27.89	1.35	0.56	2.54	
90	24.29	1.18	0.39	2.10	
105	21.58	1.05	0.26	1.62	
120	19.47	0.94	0.15	1.12	

Watts Accutrol Flow Control Roof Drains: RD-100-A-ADJ set to 1/4 open				
Design Event	Flow/Drain (L/s)	Total Flow (L/s)	Storage (m ³)	
			Ponding (cm)	Required / Provided
1:2 Year	0.71	0.71	8	2.2
1:5 Year	0.79	0.79	10	3.3
1:100 Year	0.95	0.95	15	7.5

Roof Drain Storage Table for Area RD 15		
Elevation	Area RD 1	Total Volume
m	m ²	m ³
0.00	0	0
0.05	15.9	0.4
0.10	71.9	2.6
0.15	161.7	8.4

Stage Storage Curve: Area A-5
Controlled Roof Drain #15

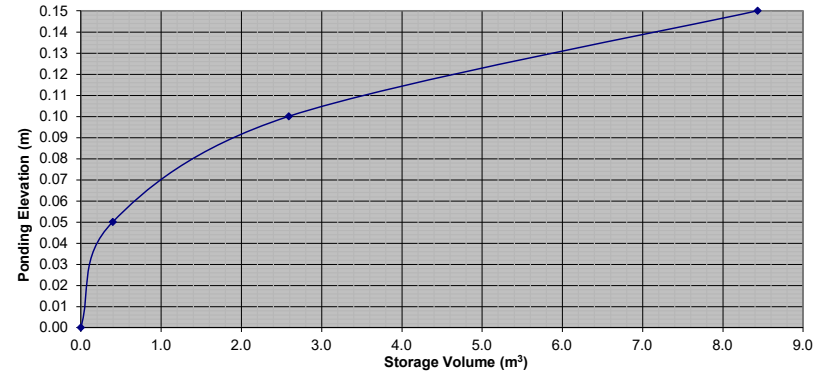

Proposed Nokia Ottawa Innovation Campus					
Novatech Project No. 123043					
REQUIRED STORAGE - 1:100 YEAR EVENT					
AREA A-5		Controlled Roof Drain #15			
OTTAWA IDF CURVE					
Area =	0.019	ha	Qallow =	0.95	L/s
C =	1.00		Vol(max) =	7.5	m3
Time (min)	Intensity (mm/hr)	Q (L/s)	Qnet (L/s)	Vol (m3)	
5	242.70	13.09	12.14	3.64	
10	178.56	9.63	8.68	5.21	
15	142.89	7.71	6.76	6.08	
20	119.95	6.47	5.52	6.62	
25	103.85	5.60	4.65	6.98	
30	91.87	4.95	4.00	7.21	
35	82.58	4.45	3.50	7.36	
40	75.15	4.05	3.10	7.45	
45	69.05	3.72	2.77	7.49	
50	63.95	3.45	2.50	7.50	
55	59.62	3.22	2.27	7.48	
60	55.89	3.01	2.06	7.43	
80	44.99	2.43	1.48	7.09	
100	37.90	2.04	1.09	6.57	
120	32.89	1.77	0.82	5.93	
140	29.15	1.57	0.62	5.23	
160	26.24	1.42	0.47	4.47	
180	23.90	1.29	0.34	3.66	

Proposed Nokia Ottawa Innovation Campus					
Novatech Project No. 123043					
REQUIRED STORAGE - 1:100 YEAR + 20%					
AREA A-5		Controlled Roof Drain #15			
OTTAWA IDF CURVE					
Area =	0.019	ha	Qallow =	0.95	L/s
C =	1.00		Vol(max) =	9.6	m3
Time (min)	Intensity (mm/hr)	Q (L/s)	Qnet (L/s)	Vol (m3)	
5	291.24	15.71	14.76	4.43	
10	214.27	11.56	10.61	6.36	
15	171.47	9.25	8.30	7.47	
20	143.94	7.76	6.81	8.18	
25	124.62	6.72	5.77	8.66	
30	110.24	5.95	5.00	8.99	
35	99.09	5.34	4.39	9.23	
40	90.17	4.86	3.91	9.39	
45	82.86	4.47	3.52	9.50	
50	76.74	4.14	3.19	9.57	
55	71.55	3.86	2.91	9.60	
60	67.07	3.62	2.67	9.60	
65	63.18	3.41	2.46	9.58	
70	59.75	3.22	2.27	9.54	
75	56.71	3.06	2.11	9.49	
90	49.33	2.66	1.71	9.24	
105	43.80	2.36	1.41	8.90	
120	39.47	2.13	1.18	8.49	

Proposed Nokia Ottawa Innovation Campus					
Novatech Project No. 123043					
REQUIRED STORAGE - 1:2 YEAR EVENT					
AREA A-5		Controlled Roof Drain #16			
OTTAWA IDF CURVE					
Area =	0.024	ha	Qallow =	0.71	L/s
C =	0.90		Vol(max) =	3.0	m3
Time (min)	Intensity (mm/hr)	Q (L/s)	Qnet (L/s)	Vol (m3)	
5	103.57	6.17	5.46	1.64	
10	76.81	4.57	3.86	2.32	
15	61.77	3.68	2.97	2.67	
20	52.03	3.10	2.39	2.87	
25	45.17	2.69	1.98	2.97	
30	40.04	2.38	1.67	3.01	
35	36.06	2.15	1.44	3.02	
40	32.86	1.96	1.25	2.99	
45	30.24	1.80	1.09	2.94	
50	28.04	1.67	0.96	2.88	
55	26.17	1.56	0.85	2.80	
60	24.56	1.46	0.75	2.71	
65	23.15	1.38	0.67	2.61	
70	21.91	1.30	0.59	2.50	
75	20.81	1.24	0.53	2.38	
90	18.14	1.08	0.37	2.00	
105	16.13	0.96	0.25	1.58	
120	14.56	0.87	0.16	1.13	

Proposed Nokia Ottawa Innovation Campus					
Novatech Project No. 123043					
REQUIRED STORAGE - 1:5 YEAR EVENT					
AREA A-5		Controlled Roof Drain #16			
OTTAWA IDF CURVE					
Area =	0.024	ha	Qallow =	0.79	L/s
C =	0.90		Vol(max) =	4.4	m3
Time (min)	Intensity (mm/hr)	Q (L/s)	Qnet (L/s)	Vol (m3)	
5	141.18	8.41	7.62	2.29	
10	104.19	6.20	5.41	3.25	
15	83.56	4.98	4.19	3.77	
20	70.25	4.18	3.39	4.07	
25	60.90	3.63	2.84	4.25	
30	53.93	3.21	2.42	4.36	
35	48.52	2.89	2.10	4.41	
40	44.18	2.63	1.84	4.42	
45	40.63	2.42	1.63	4.40	
50	37.65	2.24	1.45	4.36	
55	35.12	2.09	1.30	4.29	
60	32.94	1.96	1.17	4.22	
65	31.04	1.85	1.06	4.13	
70	29.37	1.75	0.96	4.03	
75	27.89	1.66	0.87	3.92	
90	24.29	1.45	0.66	3.54	
105	21.58	1.29	0.50	3.12	
120	19.47	1.16	0.37	2.66	

Watts Accutrol Flow Control Roof Drains: RD-100-A-ADJ set to 1/4 open					
Design Event	Flow/Drain (L/s)	Total Flow (L/s)	Ponding (cm)	Storage (m ³)	
				Required	Provided
1:2 Year	0.71	0.71	8	3.0	
1:5 Year	0.79	0.79	10	4.4	11.1
1:100 Year	0.95	0.95	15	9.9	

Roof Drain Storage Table for Area RD 16		
Elevation	Area RD 1	Total Volume
m	m ²	m ³
0.00	0	0
0.05	23.3	0.6
0.10	93.4	3.5
0.15	210.3	11.1

Proposed Nokia Ottawa Innovation Campus					
Novatech Project No. 123043					
REQUIRED STORAGE - 1:100 YEAR EVENT					
AREA A-5		Controlled Roof Drain #16			
OTTAWA IDF CURVE					
Area =	0.024	ha	Qallow =	0.95	L/s
C =	1.00		Vol(max) =	9.9	m3
Time (min)	Intensity (mm/hr)	Q (L/s)	Qnet (L/s)	Vol (m3)	
5	242.70	16.06	15.11	4.53	
10	178.56	11.81	10.86	6.52	
15	142.89	9.45	8.50	7.65	
20	119.95	7.94	6.99	8.38	
25	103.85	6.87	5.92	8.88	
30	91.87	6.08	5.13	9.23	
35	82.58	5.46	4.51	9.48	
40	75.15	4.97	4.02	9.65	
45	69.05	4.57	3.62	9.77	
50	63.95	4.23	3.28	9.84	
55	59.62	3.94	2.99	9.88	
60	55.89	3.70	2.75	9.89	
80	44.99	2.98	2.03	9.73	
100	37.90	2.51	1.56	9.35	
120	32.89	2.18	1.23	8.83	
140	29.15	1.93	0.98	8.22	
160	26.24	1.74	0.79	7.55	
180	23.90	1.58	0.63	6.82	

Proposed Nokia Ottawa Innovation Campus					
Novatech Project No. 123043					
REQUIRED STORAGE - 1:100 YEAR + 20%					
AREA A-5		Controlled Roof Drain #16			
OTTAWA IDF CURVE					
Area =	0.024	ha	Qallow =	0.95	L/s
C =	1.00		Vol(max) =	12.6	m3
Time (min)	Intensity (mm/hr)	Q (L/s)	Qnet (L/s)	Vol (m3)	
5	291.24	19.27	18.32	5.50	
10	214.27	14.18	13.23	7.94	
15	171.47	11.35	10.40	9.36	
20	143.94	9.52	8.57	10.29	
25	124.62	8.25	7.30	10.94	
30	110.24	7.29	6.34	11.42	
35	99.09	6.56	5.61	11.77	
40	90.17	5.97	5.02	12.04	
45	82.86	5.48	4.53	12.24	
50	76.74	5.08	4.13	12.38	
55	71.55	4.73	3.78	12.49	
60	67.07	4.44	3.49	12.56	
65	63.18	4.18	3.23	12.60	
70	59.75	3.95	3.00	12.61	
75	56.71	3.75	2.80	12.61	
90	49.33	3.26	2.31	12.50	
105	43.80	2.90	1.95	12.27	
120	39.47	2.61	1.66	11.96	

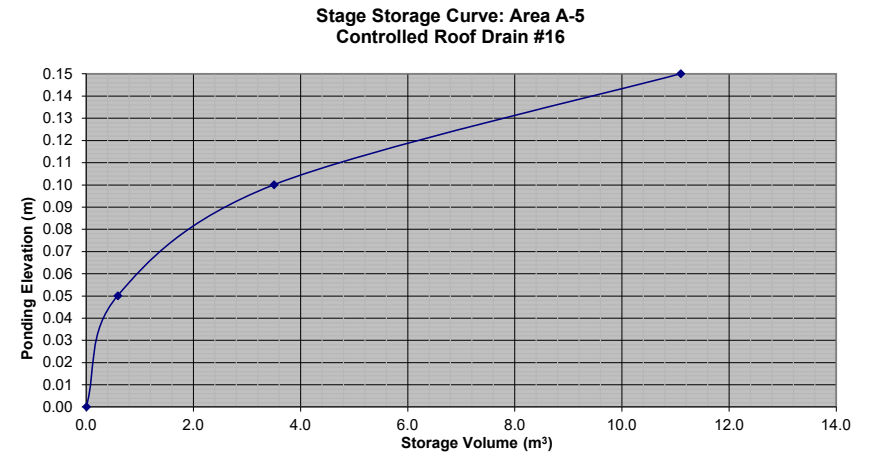

Proposed Nokia Ottawa Innovation Campus					
Novatech Project No. 123043					
REQUIRED STORAGE - 1:2 YEAR EVENT					
AREA A-5 Controlled Roof Drain #17					
OTTAWA IDF CURVE					
Area =	0.028	ha	Qallow =	0.71	L/s
C =	0.90		Vol(max) =	3.7	m ³
Time (min)	Intensity (mm/hr)	Q (L/s)	Qnet (L/s)	Vol (m ³)	
5	103.57	7.15	6.44	1.93	
10	76.81	5.30	4.59	2.76	
15	61.77	4.27	3.56	3.20	
20	52.03	3.59	2.88	3.46	
25	45.17	3.12	2.41	3.61	
30	40.04	2.77	2.06	3.70	
35	36.06	2.49	1.78	3.74	
40	32.86	2.27	1.56	3.74	
45	30.24	2.09	1.38	3.72	
50	28.04	1.94	1.23	3.68	
55	26.17	1.81	1.10	3.62	
60	24.56	1.70	0.99	3.55	
65	23.15	1.60	0.89	3.47	
70	21.91	1.51	0.80	3.37	
75	20.81	1.44	0.73	3.27	
90	18.14	1.25	0.54	2.93	
105	16.13	1.11	0.40	2.55	
120	14.56	1.01	0.30	2.13	

Proposed Nokia Ottawa Innovation Campus					
Novatech Project No. 123043					
REQUIRED STORAGE - 1:5 YEAR EVENT					
AREA A-5 Controlled Roof Drain #17					
OTTAWA IDF CURVE					
Area =	0.028	ha	Qallow =	0.79	L/s
C =	0.90		Vol(max) =	5.4	m ³
Time (min)	Intensity (mm/hr)	Q (L/s)	Qnet (L/s)	Vol (m ³)	
5	141.18	9.75	8.96	2.69	
10	104.19	7.20	6.41	3.84	
15	83.56	5.77	4.98	4.48	
20	70.25	4.85	4.06	4.87	
25	60.90	4.21	3.42	5.12	
30	53.93	3.72	2.93	5.28	
35	48.52	3.35	2.56	5.38	
40	44.18	3.05	2.26	5.43	
45	40.63	2.81	2.02	5.44	
50	37.65	2.60	1.81	5.43	
55	35.12	2.43	1.64	5.40	
60	32.94	2.27	1.48	5.35	
65	31.04	2.14	1.35	5.28	
70	29.37	2.03	1.24	5.20	
75	27.89	1.93	1.14	5.11	
90	24.29	1.68	0.89	4.79	
105	21.58	1.49	0.70	4.41	
120	19.47	1.34	0.55	3.99	

Watts Accutrol Flow Control Roof Drains: RD-100-A-ADJ set to 1/4 open					
Design Event	Flow/Drain (L/s)	Total Flow (L/s)	Storage (m ³)		
			Ponding (cm)	Required	Provided
1:2 Year	0.71	0.71	8	3.7	
1:5 Year	0.79	0.79	10	5.4	12.1
1:100 Year	0.95	0.95	15	12.0	

Roof Drain Storage Table for Area RD 17		
Elevation	Area RD 1	Total Volume
m	m ²	m ³
0.00	0	0
0.05	23.1	0.6
0.10	102.9	3.7
0.15	231.5	12.1

Proposed Nokia Ottawa Innovation Campus					
Novatech Project No. 123043					
REQUIRED STORAGE - 1:100 YEAR EVENT					
AREA A-5 Controlled Roof Drain #17					
OTTAWA IDF CURVE					
Area =	0.028	ha	Qallow =	0.95	L/s
C =	1.00		Vol(max) =	12.0	m ³
Time (min)	Intensity (mm/hr)	Q (L/s)	Qnet (L/s)	Vol (m ³)	
5	242.70	18.62	17.67	5.30	
10	178.56	13.70	12.75	7.65	
15	142.89	10.96	10.01	9.01	
20	119.95	9.20	8.25	9.90	
25	103.85	7.97	7.02	10.53	
30	91.87	7.05	6.10	10.98	
35	82.58	6.34	5.39	11.31	
40	75.15	5.77	4.82	11.56	
45	69.05	5.30	4.35	11.74	
50	63.95	4.91	3.96	11.87	
55	59.62	4.57	3.62	11.96	
60	55.89	4.29	3.34	12.02	
80	44.99	3.45	2.50	12.01	
100	37.90	2.91	1.96	11.75	
120	32.89	2.52	1.57	11.33	
140	29.15	2.24	1.29	10.81	
160	26.24	2.01	1.06	10.21	
180	23.90	1.83	0.88	9.55	

Proposed Nokia Ottawa Innovation Campus					
Novatech Project No. 123043					
REQUIRED STORAGE - 1:100 YEAR + 20%					
AREA A-5 Controlled Roof Drain #17					
OTTAWA IDF CURVE					
Area =	0.028	ha	Qallow =	0.95	L/s
C =	1.00		Vol(max) =	15.3	m ³
Time (min)	Intensity (mm/hr)	Q (L/s)	Qnet (L/s)	Vol (m ³)	
5	291.24	22.35	21.40	6.42	
10	214.27	16.44	15.49	9.29	
15	171.47	13.16	12.21	10.99	
20	143.94	11.04	10.09	12.11	
25	124.62	9.56	8.61	12.92	
30	110.24	8.46	7.51	13.52	
35	99.09	7.60	6.65	13.97	
40	90.17	6.92	5.97	14.33	
45	82.86	6.36	5.41	14.60	
50	76.74	5.89	4.94	14.82	
55	71.55	5.49	4.54	14.98	
60	67.07	5.15	4.20	15.11	
65	63.18	4.85	3.90	15.20	
70	59.75	4.58	3.63	15.26	
75	56.71	4.35	3.40	15.30	
90	49.33	3.79	2.84	15.31	
105	43.80	3.36	2.41	15.19	
120	39.47	3.03	2.08	14.97	

Stage Storage Curve: Area A-5
 Controlled Roof Drain #17

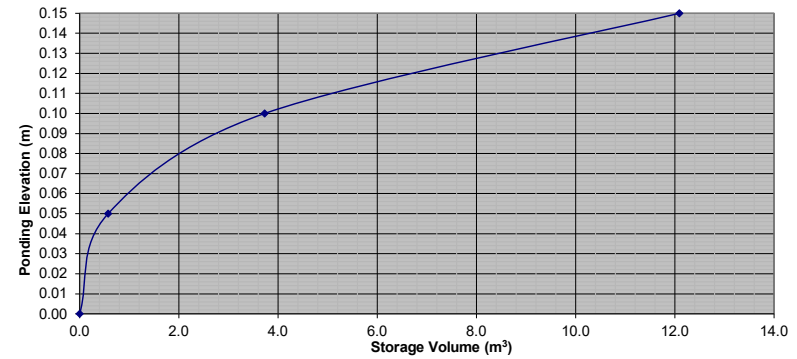

Proposed Nokia Ottawa Innovation Campus					
Novatech Project No. 123043					
REQUIRED STORAGE - 1:2 YEAR EVENT					
AREA A-5 Controlled Roof Drain #18					
OTTAWA IDF CURVE					
Area =	0.034	ha	Qallow =	0.79	L/s
C =	0.90		Vol(max) =	4.8	m3
Time (min)	Intensity (mm/hr)	Q (L/s)	Qnet (L/s)	Vol (m3)	
5	103.57	8.84	8.05	2.41	
10	76.81	6.55	5.76	3.46	
15	61.77	5.27	4.48	4.03	
20	52.03	4.44	3.65	4.38	
25	45.17	3.85	3.06	4.60	
30	40.04	3.42	2.63	4.73	
35	36.06	3.08	2.29	4.80	
40	32.86	2.80	2.01	4.83	
45	30.24	2.58	1.79	4.83	
50	28.04	2.39	1.60	4.81	
55	26.17	2.23	1.44	4.76	
60	24.56	2.10	1.31	4.70	
65	23.15	1.98	1.19	4.62	
70	21.91	1.87	1.08	4.53	
75	20.81	1.78	0.99	4.44	
90	18.14	1.55	0.76	4.09	
105	16.13	1.38	0.59	3.69	
120	14.56	1.24	0.45	3.26	

Proposed Nokia Ottawa Innovation Campus					
Novatech Project No. 123043					
REQUIRED STORAGE - 1:5 YEAR EVENT					
AREA A-5 Controlled Roof Drain #18					
OTTAWA IDF CURVE					
Area =	0.034	ha	Qallow =	0.95	L/s
C =	0.90		Vol(max) =	6.8	m3
Time (min)	Intensity (mm/hr)	Q (L/s)	Qnet (L/s)	Vol (m3)	
5	141.18	12.05	11.10	3.33	
10	104.19	8.89	7.94	4.76	
15	83.56	7.13	6.18	5.56	
20	70.25	5.99	5.04	6.05	
25	60.90	5.20	4.25	6.37	
30	53.93	4.60	3.65	6.57	
35	48.52	4.14	3.19	6.70	
40	44.18	3.77	2.82	6.77	
45	40.63	3.47	2.52	6.79	
50	37.65	3.21	2.26	6.79	
55	35.12	3.00	2.05	6.75	
60	32.94	2.81	1.86	6.70	
65	31.04	2.65	1.70	6.62	
70	29.37	2.51	1.56	6.54	
75	27.89	2.38	1.43	6.43	
90	24.29	2.07	1.12	6.06	
105	21.58	1.84	0.89	5.62	
120	19.47	1.66	0.71	5.12	

Watts Accutrol Flow Control Roof Drains: RD-100-A-ADJ set to 1/2 open					
Design Event	Flow/Drain (L/s)	Total Flow (L/s)	Ponding (cm)	Required Storage (m ³)	Provided
1:2 Year	0.79	0.79	8	4.8	
1:5 Year	0.95	0.95	10	6.8	15.1
1:100 Year	1.26	1.26	15	14.5	

Roof Drain Storage Table for Area RD 18		
Elevation	Area RD 1	Total Volume
m	m ²	m ³
0.00	0	0
0.05	28.4	0.7
0.10	128.4	4.6
0.15	289.2	15.1

Proposed Nokia Ottawa Innovation Campus					
Novatech Project No. 123043					
REQUIRED STORAGE - 1:100 YEAR EVENT					
AREA A-5 Controlled Roof Drain #18					
OTTAWA IDF CURVE					
Area =	0.034	ha	Qallow =	1.26	L/s
C =	1.00		Vol(max) =	14.5	m3
Time (min)	Intensity (mm/hr)	Q (L/s)	Qnet (L/s)	Vol (m3)	
5	242.70	23.01	21.75	6.52	
10	178.56	16.93	15.67	9.40	
15	142.89	13.55	12.29	11.06	
20	119.95	11.37	10.11	12.13	
25	103.85	9.84	8.58	12.88	
30	91.87	8.71	7.45	13.41	
35	82.58	7.83	6.57	13.79	
40	75.15	7.12	5.86	14.07	
45	69.05	6.55	5.29	14.27	
50	63.95	6.06	4.80	14.41	
55	59.62	5.65	4.39	14.49	
60	55.89	5.30	4.04	14.54	
80	44.99	4.27	3.01	14.42	
100	37.90	3.59	2.33	14.00	
120	32.89	3.12	1.86	13.38	
140	29.15	2.76	1.50	12.63	
160	26.24	2.49	1.23	11.78	
180	23.90	2.27	1.01	10.86	

Proposed Nokia Ottawa Innovation Campus					
Novatech Project No. 123043					
REQUIRED STORAGE - 1:100 YEAR + 20%					
AREA A-5 Controlled Roof Drain #18					
OTTAWA IDF CURVE					
Area =	0.034	ha	Qallow =	1.26	L/s
C =	1.00		Vol(max) =	18.5	m3
Time (min)	Intensity (mm/hr)	Q (L/s)	Qnet (L/s)	Vol (m3)	
5	291.24	27.61	26.35	7.90	
10	214.27	20.31	19.05	11.43	
15	171.47	16.26	15.00	13.50	
20	143.94	13.65	12.39	14.86	
25	124.62	11.81	10.55	15.83	
30	110.24	10.45	9.19	16.54	
35	99.09	9.39	8.13	17.08	
40	90.17	8.55	7.29	17.49	
45	82.86	7.86	6.60	17.81	
50	76.74	7.28	6.02	18.05	
55	71.55	6.78	5.52	18.22	
60	67.07	6.36	5.10	18.35	
65	63.18	5.99	4.73	18.44	
70	59.75	5.66	4.40	18.50	
75	56.71	5.38	4.12	18.52	
90	49.33	4.68	3.42	18.45	
105	43.80	4.15	2.89	18.22	
120	39.47	3.74	2.48	17.87	

Stage Storage Curve: Area A-5
 Controlled Roof Drain #18

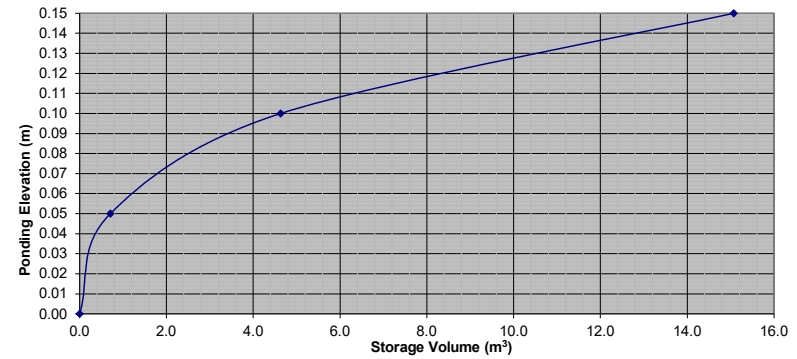

Proposed Nokia Ottawa Innovation Campus					
Novatech Project No. 123043					
REQUIRED STORAGE - 1:2 YEAR EVENT					
AREA A-6 Controlled Roof Drain #1					
OTTAWA IDF CURVE					
Area =	0.011	ha	Qallow =	0.32	L/s
C =	0.90		Vol(max) =	1.3	m3
Time (min)	Intensity (mm/hr)	Q (L/s)	Qnet (L/s)	Vol (m3)	
5	103.57	2.72	2.40	0.72	
10	76.81	2.02	1.70	1.02	
15	61.77	1.62	1.30	1.17	
20	52.03	1.37	1.05	1.26	
25	45.17	1.19	0.87	1.30	
30	40.04	1.05	0.73	1.32	
35	36.06	0.95	0.63	1.32	
40	32.86	0.86	0.54	1.30	
45	30.24	0.79	0.47	1.28	
50	28.04	0.74	0.42	1.25	
55	26.17	0.69	0.37	1.21	
60	24.56	0.65	0.33	1.17	
65	23.15	0.61	0.29	1.12	
70	21.91	0.58	0.26	1.07	
75	20.81	0.55	0.23	1.02	
90	18.14	0.48	0.16	0.85	
105	16.13	0.42	0.10	0.65	
120	14.56	0.38	0.06	0.45	

Proposed Nokia Ottawa Innovation Campus					
Novatech Project No. 123043					
REQUIRED STORAGE - 1:5 YEAR EVENT					
AREA A-6 Controlled Roof Drain #1					
OTTAWA IDF CURVE					
Area =	0.011	ha	Qallow =	0.32	L/s
C =	0.90		Vol(max) =	2.0	m3
Time (min)	Intensity (mm/hr)	Q (L/s)	Qnet (L/s)	Vol (m3)	
5	141.18	3.71	3.39	1.02	
10	104.19	2.74	2.42	1.45	
15	83.56	2.20	1.88	1.69	
20	70.25	1.85	1.53	1.83	
25	60.90	1.60	1.28	1.92	
30	53.93	1.42	1.10	1.97	
35	48.52	1.27	0.95	2.00	
40	44.18	1.16	0.84	2.02	
45	40.63	1.07	0.75	2.02	
50	37.65	0.99	0.67	2.01	
55	35.12	0.92	0.60	1.99	
60	32.94	0.87	0.55	1.96	
65	31.04	0.82	0.50	1.93	
70	29.37	0.77	0.45	1.90	
75	27.89	0.73	0.41	1.86	
90	24.29	0.64	0.32	1.72	
105	21.58	0.57	0.25	1.56	
120	19.47	0.51	0.19	1.38	

Watts Accutrol Flow Control Roof Drains: RD-100-A-ADJ set to closed					
Design Event	Flow/Drain (L/s)	Total Flow (L/s)	Ponding (cm)	Required Storage (m ³)	Provided
1:2 Year	0.32	0.32	8	1.3	
1:5 Year	0.32	0.32	10	2.0	8.6
1:100 Year	0.32	0.32	15	4.8	

Roof Drain Storage Table for Area RD 1		
Elevation	Area RD 1	Total Volume
m	m ²	m ³
0.00	0	0
0.05	18.1	0.5
0.10	72.2	2.7
0.15	163.3	8.6

Proposed Nokia Ottawa Innovation Campus					
Novatech Project No. 123043					
REQUIRED STORAGE - 1:100 YEAR EVENT					
AREA A-6 Controlled Roof Drain #1					
OTTAWA IDF CURVE					
Area =	0.011	ha	Qallow =	0.32	L/s
C =	1.00		Vol(max) =	4.8	m3
Time (min)	Intensity (mm/hr)	Q (L/s)	Qnet (L/s)	Vol (m3)	
5	242.70	7.08	6.76	2.03	
10	178.56	5.21	4.89	2.94	
15	142.89	4.17	3.85	3.47	
20	119.95	3.50	3.18	3.82	
25	103.85	3.03	2.71	4.07	
30	91.87	2.68	2.36	4.25	
35	82.58	2.41	2.09	4.39	
40	75.15	2.19	1.87	4.50	
45	69.05	2.02	1.70	4.58	
50	63.95	1.87	1.55	4.64	
55	59.62	1.74	1.42	4.69	
60	55.89	1.63	1.31	4.72	
80	44.99	1.31	0.99	4.77	
100	37.90	1.11	0.79	4.72	
120	32.89	0.96	0.64	4.61	
140	29.15	0.85	0.53	4.46	
160	26.24	0.77	0.45	4.28	
180	23.90	0.70	0.38	4.08	

Proposed Nokia Ottawa Innovation Campus					
Novatech Project No. 123043					
REQUIRED STORAGE - 1:100 YEAR + 20%					
AREA A-6 Controlled Roof Drain #1					
OTTAWA IDF CURVE					
Area =	0.011	ha	Qallow =	0.32	L/s
C =	1.00		Vol(max) =	6.0	m3
Time (min)	Intensity (mm/hr)	Q (L/s)	Qnet (L/s)	Vol (m3)	
5	291.24	8.50	8.18	2.45	
10	214.27	6.25	5.93	3.56	
15	171.47	5.01	4.69	4.22	
20	143.94	4.20	3.88	4.66	
25	124.62	3.64	3.32	4.98	
30	110.24	3.22	2.90	5.22	
35	99.09	2.89	2.57	5.40	
40	90.17	2.63	2.31	5.55	
45	82.86	2.42	2.10	5.67	
50	76.74	2.24	1.92	5.76	
55	71.55	2.09	1.77	5.84	
60	67.07	1.96	1.64	5.90	
65	63.18	1.84	1.52	5.94	
70	59.75	1.74	1.42	5.98	
75	56.71	1.66	1.34	6.01	
90	49.33	1.44	1.12	6.05	
105	43.80	1.28	0.96	6.04	
120	39.47	1.15	0.83	5.99	

Stage Storage Curve: Area A-6
 Controlled Roof Drain #1

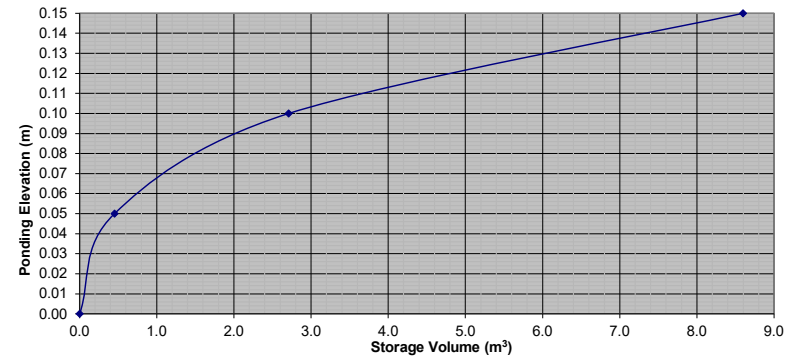

Proposed Nokia Ottawa Innovation Campus					
Novatech Project No. 123043					
REQUIRED STORAGE - 1:2 YEAR EVENT					
AREA A-6 Controlled Roof Drain #2					
OTTAWA IDF CURVE					
Area =	0.029	ha	Qallow =	0.71	L/s
C =	0.90		Vol(max) =	4.1	m3
Time (min)	Intensity (mm/hr)	Q (L/s)	Qnet (L/s)	Vol (m3)	
5	103.57	7.59	6.88	2.06	
10	76.81	5.63	4.92	2.95	
15	61.77	4.53	3.82	3.44	
20	52.03	3.81	3.10	3.73	
25	45.17	3.31	2.60	3.90	
30	40.04	2.94	2.23	4.01	
35	36.06	2.64	1.93	4.06	
40	32.86	2.41	1.70	4.08	
45	30.24	2.22	1.51	4.07	
50	28.04	2.06	1.35	4.04	
55	26.17	1.92	1.21	3.99	
60	24.56	1.80	1.09	3.93	
65	23.15	1.70	0.99	3.85	
70	21.91	1.61	0.90	3.76	
75	20.81	1.53	0.82	3.67	
90	18.14	1.33	0.62	3.35	
105	16.13	1.18	0.47	2.98	
120	14.56	1.07	0.36	2.57	

Proposed Nokia Ottawa Innovation Campus					
Novatech Project No. 123043					
REQUIRED STORAGE - 1:5 YEAR EVENT					
AREA A-6 Controlled Roof Drain #2					
OTTAWA IDF CURVE					
Area =	0.029	ha	Qallow =	0.79	L/s
C =	0.90		Vol(max) =	5.9	m3
Time (min)	Intensity (mm/hr)	Q (L/s)	Qnet (L/s)	Vol (m3)	
5	141.18	10.35	9.56	2.87	
10	104.19	7.64	6.85	4.11	
15	83.56	6.13	5.34	4.80	
20	70.25	5.15	4.36	5.23	
25	60.90	4.46	3.67	5.51	
30	53.93	3.95	3.16	5.69	
35	48.52	3.56	2.77	5.81	
40	44.18	3.24	2.45	5.88	
45	40.63	2.98	2.19	5.91	
50	37.65	2.76	1.97	5.91	
55	35.12	2.57	1.78	5.89	
60	32.94	2.42	1.63	5.85	
65	31.04	2.28	1.49	5.79	
70	29.37	2.15	1.36	5.73	
75	27.89	2.04	1.25	5.65	
90	24.29	1.78	0.99	5.35	
105	21.58	1.58	0.79	4.99	
120	19.47	1.43	0.64	4.59	

Watts Accutrol Flow Control Roof Drains: RD-100-A-ADJ set to 1/4 open					
Design Event	Flow/Drain (L/s)	Total Flow (L/s)	Ponding (cm)	Required Storage (m ³)	Provided
1:2 Year	0.71	0.71	8	4.1	
1:5 Year	0.79	0.79	10	5.9	16.6
1:100 Year	0.95	0.95	15	13.0	

Roof Drain Storage Table for Area RD 2		
Elevation	Area RD 1	Total Volume
m	m ²	m ³
0.00	0	0
0.05	35.1	0.9
0.10	143.3	5.3
0.15	307.8	16.6

Proposed Nokia Ottawa Innovation Campus					
Novatech Project No. 123043					
REQUIRED STORAGE - 1:100 YEAR EVENT					
AREA A-6 Controlled Roof Drain #2					
OTTAWA IDF CURVE					
Area =	0.029	ha	Qallow =	0.95	L/s
C =	1.00		Vol(max) =	13.0	m3
Time (min)	Intensity (mm/hr)	Q (L/s)	Qnet (L/s)	Vol (m3)	
5	242.70	19.77	18.82	5.65	
10	178.56	14.54	13.59	8.16	
15	142.89	11.64	10.69	9.62	
20	119.95	9.77	8.82	10.58	
25	103.85	8.46	7.51	11.26	
30	91.87	7.48	6.53	11.76	
35	82.58	6.73	5.78	12.13	
40	75.15	6.12	5.17	12.41	
45	69.05	5.62	4.67	12.62	
50	63.95	5.21	4.26	12.78	
55	59.62	4.86	3.91	12.89	
60	55.89	4.55	3.60	12.97	
80	44.99	3.66	2.71	13.03	
100	37.90	3.09	2.14	12.82	
120	32.89	2.68	1.73	12.45	
140	29.15	2.37	1.42	11.97	
160	26.24	2.14	1.19	11.40	
180	23.90	1.95	1.00	10.77	

Proposed Nokia Ottawa Innovation Campus					
Novatech Project No. 123043					
REQUIRED STORAGE - 1:100 YEAR + 20%					
AREA A-6 Controlled Roof Drain #2					
OTTAWA IDF CURVE					
Area =	0.029	ha	Qallow =	0.95	L/s
C =	1.00		Vol(max) =	16.6	m3
Time (min)	Intensity (mm/hr)	Q (L/s)	Qnet (L/s)	Vol (m3)	
5	291.24	23.72	22.77	6.83	
10	214.27	17.45	16.50	9.90	
15	171.47	13.97	13.02	11.72	
20	143.94	11.72	10.77	12.93	
25	124.62	10.15	9.20	13.80	
30	110.24	8.98	8.03	14.45	
35	99.09	8.07	7.12	14.96	
40	90.17	7.35	6.40	15.35	
45	82.86	6.75	5.80	15.66	
50	76.74	6.25	5.30	15.90	
55	71.55	5.83	4.88	16.10	
60	67.07	5.46	4.51	16.25	
65	63.18	5.15	4.20	16.36	
70	59.75	4.87	3.92	16.45	
75	56.71	4.62	3.67	16.51	
90	49.33	4.02	3.07	16.57	
105	43.80	3.57	2.62	16.49	
120	39.47	3.22	2.27	16.31	

Stage Storage Curve: Area A-6
 Controlled Roof Drain #2

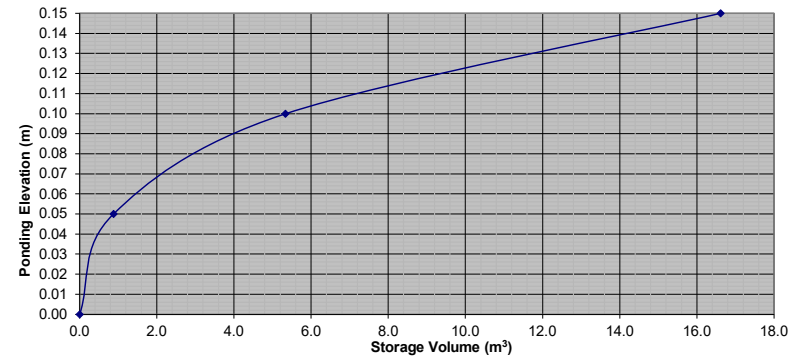

Proposed Nokia Ottawa Innovation Campus					
Novatech Project No. 123043					
REQUIRED STORAGE - 1:2 YEAR EVENT					
AREA A-6 Controlled Roof Drain #3					
OTTAWA IDF CURVE					
Area =	0.007	ha	Qallow =	0.32	L/s
C =	0.90		Vol(max) =	0.7	m ³
Time (min)	Intensity (mm/hr)	Q (L/s)	Qnet (L/s)	Vol (m ³)	
5	103.57	1.87	1.55	0.46	
10	76.81	1.38	1.06	0.64	
15	61.77	1.11	0.79	0.71	
20	52.03	0.94	0.62	0.74	
25	45.17	0.81	0.49	0.74	
30	40.04	0.72	0.40	0.72	
35	36.06	0.65	0.33	0.69	
40	32.86	0.59	0.27	0.65	
45	30.24	0.54	0.22	0.61	
50	28.04	0.51	0.19	0.56	
55	26.17	0.47	0.15	0.50	
60	24.56	0.44	0.12	0.44	
65	23.15	0.42	0.10	0.38	
70	21.91	0.39	0.07	0.31	
75	20.81	0.37	0.05	0.25	
90	18.14	0.33	0.01	0.04	
105	16.13	0.29	-0.03	-0.18	
120	14.56	0.26	-0.06	-0.42	

Proposed Nokia Ottawa Innovation Campus					
Novatech Project No. 123043					
REQUIRED STORAGE - 1:5 YEAR EVENT					
AREA A-6 Controlled Roof Drain #3					
OTTAWA IDF CURVE					
Area =	0.007	ha	Qallow =	0.32	L/s
C =	0.90		Vol(max) =	1.2	m ³
Time (min)	Intensity (mm/hr)	Q (L/s)	Qnet (L/s)	Vol (m ³)	
5	141.18	2.54	2.22	0.67	
10	104.19	1.88	1.56	0.93	
15	83.56	1.51	1.19	1.07	
20	70.25	1.27	0.95	1.13	
25	60.90	1.10	0.78	1.17	
30	53.93	0.97	0.65	1.17	
35	48.52	0.87	0.55	1.16	
40	44.18	0.80	0.48	1.14	
45	40.63	0.73	0.41	1.11	
50	37.65	0.68	0.36	1.07	
55	35.12	0.63	0.31	1.03	
60	32.94	0.59	0.27	0.98	
65	31.04	0.56	0.24	0.93	
70	29.37	0.53	0.21	0.88	
75	27.89	0.50	0.18	0.82	
90	24.29	0.44	0.12	0.63	
105	21.58	0.39	0.07	0.43	
120	19.47	0.35	0.03	0.22	

Watts Accutrol Flow Control Roof Drains: RD-100-A-ADJ set to closed					
Design Event	Flow/Drain (L/s)	Total Flow (L/s)	Ponding (cm)	Storage (m ³)	
				Required	Provided
1:2 Year	0.32	0.32	8	0.7	
1:5 Year	0.32	0.32	10	1.2	3.8
1:100 Year	0.32	0.32	15	2.9	

Roof Drain Storage Table for Area RD 3		
Elevation	Area RD 1	Total Volume
m	m ²	m ³
0.00	0	0
0.05	7.9	0.2
0.10	32.1	1.2
0.15	71.8	3.8

Proposed Nokia Ottawa Innovation Campus					
Novatech Project No. 123043					
REQUIRED STORAGE - 1:100 YEAR EVENT					
AREA A-6 Controlled Roof Drain #3					
OTTAWA IDF CURVE					
Area =	0.007	ha	Qallow =	0.32	L/s
C =	1.00		Vol(max) =	2.9	m ³
Time (min)	Intensity (mm/hr)	Q (L/s)	Qnet (L/s)	Vol (m ³)	
5	242.70	4.86	4.54	1.36	
10	178.56	3.57	3.25	1.95	
15	142.89	2.86	2.54	2.29	
20	119.95	2.40	2.08	2.50	
25	103.85	2.08	1.76	2.64	
30	91.87	1.84	1.52	2.73	
35	82.58	1.65	1.33	2.80	
40	75.15	1.50	1.18	2.84	
45	69.05	1.38	1.06	2.87	
50	63.95	1.28	0.96	2.88	
55	59.62	1.19	0.87	2.88	
60	55.89	1.12	0.80	2.88	
80	44.99	0.90	0.58	2.79	
100	37.90	0.76	0.44	2.63	
120	32.89	0.66	0.34	2.44	
140	29.15	0.58	0.26	2.21	
160	26.24	0.53	0.21	1.97	
180	23.90	0.48	0.16	1.71	

Proposed Nokia Ottawa Innovation Campus					
Novatech Project No. 123043					
REQUIRED STORAGE - 1:100 YEAR + 20%					
AREA A-6 Controlled Roof Drain #3					
OTTAWA IDF CURVE					
Area =	0.007	ha	Qallow =	0.32	L/s
C =	1.00		Vol(max) =	3.7	m ³
Time (min)	Intensity (mm/hr)	Q (L/s)	Qnet (L/s)	Vol (m ³)	
5	291.24	5.83	5.51	1.65	
10	214.27	4.29	3.97	2.38	
15	171.47	3.43	3.11	2.80	
20	143.94	2.88	2.56	3.07	
25	124.62	2.49	2.17	3.26	
30	110.24	2.21	1.89	3.40	
35	99.09	1.98	1.66	3.49	
40	90.17	1.80	1.48	3.56	
45	82.86	1.66	1.34	3.61	
50	76.74	1.54	1.22	3.65	
55	71.55	1.43	1.11	3.67	
60	67.07	1.34	1.02	3.68	
65	63.18	1.26	0.94	3.68	
70	59.75	1.20	0.88	3.68	
75	56.71	1.14	0.82	3.67	
90	49.33	0.99	0.67	3.60	
105	43.80	0.88	0.56	3.51	
120	39.47	0.79	0.47	3.38	

Stage Storage Curve: Area A-6
 Controlled Roof Drain #3

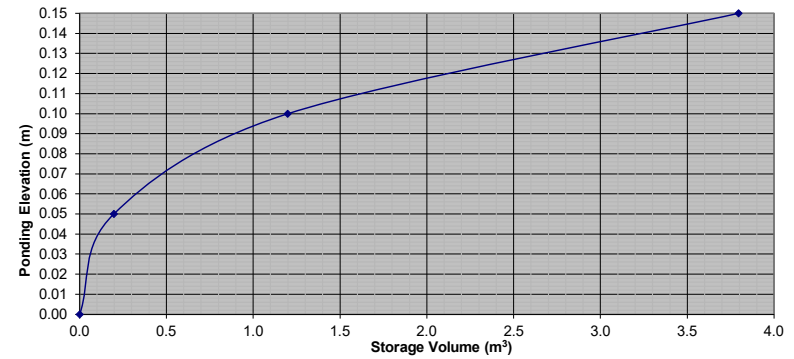

Proposed Nokia Ottawa Innovation Campus					
Novatech Project No. 123043					
REQUIRED STORAGE - 1:2 YEAR EVENT					
AREA A-6 Controlled Roof Drain #4					
OTTAWA IDF CURVE					
Area =	0.007	ha	Qallow =	0.32	L/s
C =	0.90		Vol(max) =	0.7	m3
Time (min)	Intensity (mm/hr)	Q (L/s)	Qnet (L/s)	Vol (m3)	
5	103.57	1.81	1.49	0.45	
10	76.81	1.35	1.03	0.62	
15	61.77	1.08	0.76	0.69	
20	52.03	0.91	0.59	0.71	
25	45.17	0.79	0.47	0.71	
30	40.04	0.70	0.38	0.69	
35	36.06	0.63	0.31	0.65	
40	32.86	0.58	0.26	0.61	
45	30.24	0.53	0.21	0.57	
50	28.04	0.49	0.17	0.51	
55	26.17	0.46	0.14	0.46	
60	24.56	0.43	0.11	0.40	
65	23.15	0.41	0.09	0.33	
70	21.91	0.38	0.06	0.27	
75	20.81	0.36	0.04	0.20	
90	18.14	0.32	0.00	-0.01	
105	16.13	0.28	-0.04	-0.24	
120	14.56	0.26	-0.06	-0.47	

Proposed Nokia Ottawa Innovation Campus					
Novatech Project No. 123043					
REQUIRED STORAGE - 1:5 YEAR EVENT					
AREA A-6 Controlled Roof Drain #4					
OTTAWA IDF CURVE					
Area =	0.007	ha	Qallow =	0.32	L/s
C =	0.90		Vol(max) =	1.1	m3
Time (min)	Intensity (mm/hr)	Q (L/s)	Qnet (L/s)	Vol (m3)	
5	141.18	2.47	2.15	0.65	
10	104.19	1.82	1.50	0.90	
15	83.56	1.46	1.14	1.03	
20	70.25	1.23	0.91	1.09	
25	60.90	1.07	0.75	1.12	
30	53.93	0.94	0.62	1.12	
35	48.52	0.85	0.53	1.11	
40	44.18	0.77	0.45	1.09	
45	40.63	0.71	0.39	1.06	
50	37.65	0.66	0.34	1.02	
55	35.12	0.62	0.30	0.97	
60	32.94	0.58	0.26	0.93	
65	31.04	0.54	0.22	0.87	
70	29.37	0.51	0.19	0.82	
75	27.89	0.49	0.17	0.76	
90	24.29	0.43	0.11	0.57	
105	21.58	0.38	0.06	0.37	
120	19.47	0.34	0.02	0.15	

Watts Accutrol Flow Control Roof Drains: RD-100-A-ADJ set to closed					
Design Event	Flow/Drain (L/s)	Total Flow (L/s)	Ponding (cm)	Storage (m ³)	
				Required	Provided
1:2 Year	0.32	0.32	8	0.7	
1:5 Year	0.32	0.32	10	1.1	3.8
1:100 Year	0.32	0.32	15	2.8	

Roof Drain Storage Table for Area RD 4		
Elevation	Area RD 1	Total Volume
m	m ²	m ³
0.00	0	0
0.05	7.9	0.2
0.10	32.1	1.2
0.15	71.8	3.8

Proposed Nokia Ottawa Innovation Campus					
Novatech Project No. 123043					
REQUIRED STORAGE - 1:100 YEAR EVENT					
AREA A-6 Controlled Roof Drain #4					
OTTAWA IDF CURVE					
Area =	0.007	ha	Qallow =	0.32	L/s
C =	1.00		Vol(max) =	2.8	m3
Time (min)	Intensity (mm/hr)	Q (L/s)	Qnet (L/s)	Vol (m3)	
5	242.70	4.72	4.40	1.32	
10	178.56	3.47	3.15	1.89	
15	142.89	2.78	2.46	2.21	
20	119.95	2.33	2.01	2.42	
25	103.85	2.02	1.70	2.55	
30	91.87	1.79	1.47	2.64	
35	82.58	1.61	1.29	2.70	
40	75.15	1.46	1.14	2.74	
45	69.05	1.34	1.02	2.76	
50	63.95	1.24	0.92	2.77	
55	59.62	1.16	0.84	2.77	
60	55.89	1.09	0.77	2.76	
80	44.99	0.88	0.56	2.67	
100	37.90	0.74	0.42	2.51	
120	32.89	0.64	0.32	2.30	
140	29.15	0.57	0.25	2.08	
160	26.24	0.51	0.19	1.83	
180	23.90	0.47	0.15	1.57	

Proposed Nokia Ottawa Innovation Campus					
Novatech Project No. 123043					
REQUIRED STORAGE - 1:100 YEAR + 20%					
AREA A-6 Controlled Roof Drain #4					
OTTAWA IDF CURVE					
Area =	0.007	ha	Qallow =	0.32	L/s
C =	1.00		Vol(max) =	3.5	m3
Time (min)	Intensity (mm/hr)	Q (L/s)	Qnet (L/s)	Vol (m3)	
5	291.24	5.67	5.35	1.60	
10	214.27	4.17	3.85	2.31	
15	171.47	3.34	3.02	2.72	
20	143.94	2.80	2.48	2.98	
25	124.62	2.43	2.11	3.16	
30	110.24	2.15	1.83	3.29	
35	99.09	1.93	1.61	3.38	
40	90.17	1.75	1.43	3.44	
45	82.86	1.61	1.29	3.49	
50	76.74	1.49	1.17	3.52	
55	71.55	1.39	1.07	3.54	
60	67.07	1.31	0.99	3.55	
65	63.18	1.23	0.91	3.55	
70	59.75	1.16	0.84	3.54	
75	56.71	1.10	0.78	3.53	
90	49.33	0.96	0.64	3.46	
105	43.80	0.85	0.53	3.35	
120	39.47	0.77	0.45	3.23	

Stage Storage Curve: Area A-6
 Controlled Roof Drain #4

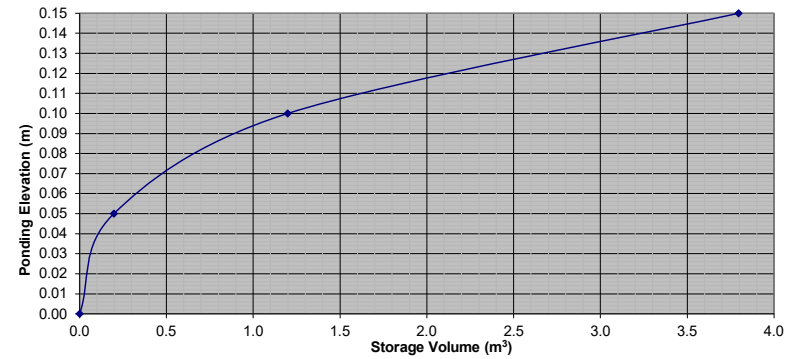

Proposed Nokia Ottawa Innovation Campus Novatech Project No. 123043 REQUIRED STORAGE - 1:2 YEAR EVENT AREA A-6 Controlled Roof Drain #5					
OTTAWA IDF CURVE					
Area =	0.005	ha	Qallow =	0.32	L/s
C =	0.90		Vol(max) =	0.5	m3
Time (min)	Intensity (mm/hr)	Q (L/s)	Qnet (L/s)	Vol (m3)	
5	103.57	1.40	1.08	0.32	
10	76.81	1.04	0.72	0.43	
15	61.77	0.83	0.51	0.46	
20	52.03	0.70	0.38	0.46	
25	45.17	0.61	0.29	0.44	
30	40.04	0.54	0.22	0.40	
35	36.06	0.49	0.17	0.35	
40	32.86	0.44	0.12	0.30	
45	30.24	0.41	0.09	0.24	
50	28.04	0.38	0.06	0.18	
55	26.17	0.35	0.03	0.11	
60	24.56	0.33	0.01	0.04	
65	23.15	0.31	-0.01	-0.03	
70	21.91	0.30	-0.02	-0.10	
75	20.81	0.28	-0.04	-0.17	
90	18.14	0.25	-0.07	-0.40	
105	16.13	0.22	-0.10	-0.64	
120	14.56	0.20	-0.12	-0.89	

Proposed Nokia Ottawa Innovation Campus Novatech Project No. 123043 REQUIRED STORAGE - 1:5 YEAR EVENT AREA A-6 Controlled Roof Drain #5					
OTTAWA IDF CURVE					
Area =	0.005	ha	Qallow =	0.32	L/s
C =	0.90		Vol(max) =	0.8	m3
Time (min)	Intensity (mm/hr)	Q (L/s)	Qnet (L/s)	Vol (m3)	
5	141.18	1.91	1.59	0.48	
10	104.19	1.41	1.09	0.65	
15	83.56	1.13	0.81	0.73	
20	70.25	0.95	0.63	0.75	
25	60.90	0.82	0.50	0.75	
30	53.93	0.73	0.41	0.74	
35	48.52	0.66	0.34	0.70	
40	44.18	0.60	0.28	0.66	
45	40.63	0.55	0.23	0.62	
50	37.65	0.51	0.19	0.57	
55	35.12	0.47	0.15	0.51	
60	32.94	0.45	0.13	0.45	
65	31.04	0.42	0.10	0.39	
70	29.37	0.40	0.08	0.32	
75	27.89	0.38	0.06	0.26	
90	24.29	0.33	0.01	0.04	
105	21.58	0.29	-0.03	-0.18	
120	19.47	0.26	-0.06	-0.41	

Watts Accutrol Flow Control Roof Drains: RD-100-A-ADJ set to closed					
Design Event	Flow/Drain (L/s)	Total Flow (L/s)	Ponding (cm)	Required Storage (m ³)	Provided
1:2 Year	0.32	0.32	8	0.5	
1:5 Year	0.32	0.32	10	0.8	2.2
1:100 Year	0.32	0.32	15	1.9	

Roof Drain Storage Table for Area RD 5		
Elevation	Area RD 1	Total Volume
m	m ²	m ³
0.00	0	0
0.05	4.6	0.1
0.10	18.5	0.7
0.15	41.7	2.2

Proposed Nokia Ottawa Innovation Campus Novatech Project No. 123043 REQUIRED STORAGE - 1:100 YEAR EVENT AREA A-6 Controlled Roof Drain #5					
OTTAWA IDF CURVE					
Area =	0.005	ha	Qallow =	0.32	L/s
C =	1.00		Vol(max) =	1.9	m3
Time (min)	Intensity (mm/hr)	Q (L/s)	Qnet (L/s)	Vol (m3)	
5	242.70	3.64	3.32	1.00	
10	178.56	2.68	2.36	1.42	
15	142.89	2.15	1.83	1.64	
20	119.95	1.80	1.48	1.78	
25	103.85	1.56	1.24	1.86	
30	91.87	1.38	1.06	1.91	
35	82.58	1.24	0.92	1.93	
40	75.15	1.13	0.81	1.94	
45	69.05	1.04	0.72	1.93	
50	63.95	0.96	0.64	1.92	
55	59.62	0.90	0.58	1.90	
60	55.89	0.84	0.52	1.87	
80	44.99	0.68	0.36	1.71	
100	37.90	0.57	0.25	1.49	
120	32.89	0.49	0.17	1.25	
140	29.15	0.44	0.12	0.99	
160	26.24	0.39	0.07	0.71	
180	23.90	0.36	0.04	0.42	

Proposed Nokia Ottawa Innovation Campus Novatech Project No. 123043 REQUIRED STORAGE - 1:100 YEAR + 20% AREA A-6 Controlled Roof Drain #5					
OTTAWA IDF CURVE					
Area =	0.005	ha	Qallow =	0.32	L/s
C =	1.00		Vol(max) =	2.5	m3
Time (min)	Intensity (mm/hr)	Q (L/s)	Qnet (L/s)	Vol (m3)	
5	291.24	4.37	4.05	1.22	
10	214.27	3.22	2.90	1.74	
15	171.47	2.57	2.25	2.03	
20	143.94	2.16	1.84	2.21	
25	124.62	1.87	1.55	2.33	
30	110.24	1.65	1.33	2.40	
35	99.09	1.49	1.17	2.45	
40	90.17	1.35	1.03	2.48	
45	82.86	1.24	0.92	2.49	
50	76.74	1.15	0.83	2.50	
55	71.55	1.07	0.75	2.49	
60	67.07	1.01	0.69	2.47	
65	63.18	0.95	0.63	2.45	
70	59.75	0.90	0.58	2.42	
75	56.71	0.85	0.53	2.39	
90	49.33	0.74	0.42	2.27	
105	43.80	0.66	0.34	2.13	
120	39.47	0.59	0.27	1.96	

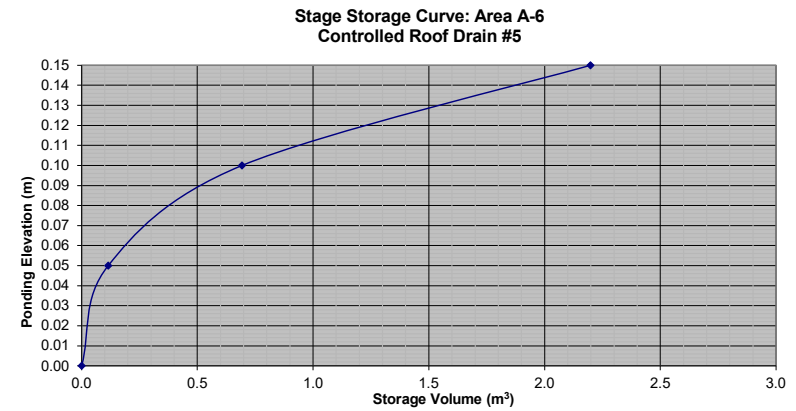

Proposed Nokia Ottawa Innovation Campus					
Novatech Project No. 123043					
REQUIRED STORAGE - 1:2 YEAR EVENT					
AREA A-6		Controlled Roof Drain #6			
OTTAWA IDF CURVE					
Area =	0.005	ha	Qallow =	0.32	L/s
C =	0.90		Vol(max) =	0.4	m ³
Time (min)	Intensity (mm/hr)	Q (L/s)	Qnet (L/s)	Vol (m ³)	
5	103.57	1.37	1.05	0.32	
10	76.81	1.02	0.70	0.42	
15	61.77	0.82	0.50	0.45	
20	52.03	0.69	0.37	0.44	
25	45.17	0.60	0.28	0.42	
30	40.04	0.53	0.21	0.38	
35	36.06	0.48	0.16	0.33	
40	32.86	0.44	0.12	0.28	
45	30.24	0.40	0.08	0.22	
50	28.04	0.37	0.05	0.16	
55	26.17	0.35	0.03	0.09	
60	24.56	0.33	0.01	0.02	
65	23.15	0.31	-0.01	-0.05	
70	21.91	0.29	-0.03	-0.12	
75	20.81	0.28	-0.04	-0.20	
90	18.14	0.24	-0.08	-0.43	
105	16.13	0.21	-0.11	-0.67	
120	14.56	0.19	-0.13	-0.91	

Proposed Nokia Ottawa Innovation Campus					
Novatech Project No. 123043					
REQUIRED STORAGE - 1:5 YEAR EVENT					
AREA A-6		Controlled Roof Drain #6			
OTTAWA IDF CURVE					
Area =	0.005	ha	Qallow =	0.32	L/s
C =	0.90		Vol(max) =	0.7	m ³
Time (min)	Intensity (mm/hr)	Q (L/s)	Qnet (L/s)	Vol (m ³)	
5	141.18	1.87	1.55	0.47	
10	104.19	1.38	1.06	0.64	
15	83.56	1.11	0.79	0.71	
20	70.25	0.93	0.61	0.73	
25	60.90	0.81	0.49	0.73	
30	53.93	0.72	0.40	0.71	
35	48.52	0.64	0.32	0.68	
40	44.18	0.59	0.27	0.64	
45	40.63	0.54	0.22	0.59	
50	37.65	0.50	0.18	0.54	
55	35.12	0.47	0.15	0.48	
60	32.94	0.44	0.12	0.42	
65	31.04	0.41	0.09	0.36	
70	29.37	0.39	0.07	0.29	
75	27.89	0.37	0.05	0.22	
90	24.29	0.32	0.00	0.01	
105	21.58	0.29	-0.03	-0.21	
120	19.47	0.26	-0.06	-0.45	

Watts Accutrol Flow Control Roof Drains: RD-100-A-ADJ set to closed					
Design Event	Flow/Drain (L/s)	Total Flow (L/s)	Ponding (cm)	Required Storage (m ³)	Provided
1:2 Year	0.32	0.32	8	0.4	
1:5 Year	0.32	0.32	10	0.7	2.2
1:100 Year	0.32	0.32	15	1.9	

Roof Drain Storage Table for Area RD 6		
Elevation	Area RD 1	Total Volume
m	m ²	m ³
0.00	0	0
0.05	4.6	0.1
0.10	18.5	0.7
0.15	41.7	2.2

Proposed Nokia Ottawa Innovation Campus					
Novatech Project No. 123043					
REQUIRED STORAGE - 1:100 YEAR EVENT					
AREA A-6		Controlled Roof Drain #6			
OTTAWA IDF CURVE					
Area =	0.005	ha	Qallow =	0.32	L/s
C =	1.00		Vol(max) =	1.9	m ³
Time (min)	Intensity (mm/hr)	Q (L/s)	Qnet (L/s)	Vol (m ³)	
5	242.70	3.58	3.26	0.98	
10	178.56	2.63	2.31	1.39	
15	142.89	2.11	1.79	1.61	
20	119.95	1.77	1.45	1.74	
25	103.85	1.53	1.21	1.82	
30	91.87	1.35	1.03	1.86	
35	82.58	1.22	0.90	1.88	
40	75.15	1.11	0.79	1.89	
45	69.05	1.02	0.70	1.88	
50	63.95	0.94	0.62	1.87	
55	59.62	0.88	0.56	1.84	
60	55.89	0.82	0.50	1.81	
80	44.99	0.66	0.34	1.65	
100	37.90	0.56	0.24	1.43	
120	32.89	0.48	0.16	1.19	
140	29.15	0.43	0.11	0.92	
160	26.24	0.39	0.07	0.64	
180	23.90	0.35	0.03	0.35	

Proposed Nokia Ottawa Innovation Campus					
Novatech Project No. 123043					
REQUIRED STORAGE - 1:100 YEAR + 20%					
AREA A-6		Controlled Roof Drain #6			
OTTAWA IDF CURVE					
Area =	0.005	ha	Qallow =	0.32	L/s
C =	1.00		Vol(max) =	2.4	m ³
Time (min)	Intensity (mm/hr)	Q (L/s)	Qnet (L/s)	Vol (m ³)	
5	291.24	4.29	3.97	1.19	
10	214.27	3.16	2.84	1.70	
15	171.47	2.53	2.21	1.99	
20	143.94	2.12	1.80	2.16	
25	124.62	1.84	1.52	2.27	
30	110.24	1.62	1.30	2.35	
35	99.09	1.46	1.14	2.39	
40	90.17	1.33	1.01	2.42	
45	82.86	1.22	0.90	2.43	
50	76.74	1.13	0.81	2.43	
55	71.55	1.05	0.73	2.42	
60	67.07	0.99	0.67	2.41	
65	63.18	0.93	0.61	2.38	
70	59.75	0.88	0.56	2.35	
75	56.71	0.84	0.52	2.32	
90	49.33	0.73	0.41	2.20	
105	43.80	0.65	0.33	2.05	
120	39.47	0.58	0.26	1.88	

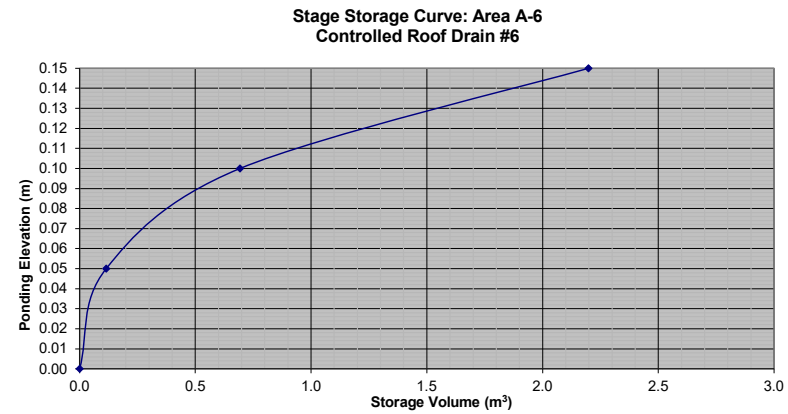

Proposed Nokia Ottawa Innovation Campus					
Novatech Project No. 123043					
REQUIRED STORAGE - 1:2 YEAR EVENT					
AREA A-6 Controlled Roof Drain #7					
OTTAWA IDF CURVE					
Area =	0.022	ha	Qallow =	0.71	L/s
C =	0.90		Vol(max) =	2.7	m ³
Time (min)	Intensity (mm/hr)	Q (L/s)	Qnet (L/s)	Vol (m ³)	
5	103.57	5.73	5.02	1.51	
10	76.81	4.25	3.54	2.12	
15	61.77	3.42	2.71	2.43	
20	52.03	2.88	2.17	2.60	
25	45.17	2.50	1.79	2.68	
30	40.04	2.21	1.50	2.71	
35	36.06	1.99	1.28	2.70	
40	32.86	1.82	1.11	2.66	
45	30.24	1.67	0.96	2.60	
50	28.04	1.55	0.84	2.52	
55	26.17	1.45	0.74	2.43	
60	24.56	1.36	0.65	2.33	
65	23.15	1.28	0.57	2.22	
70	21.91	1.21	0.50	2.11	
75	20.81	1.15	0.44	1.98	
90	18.14	1.00	0.29	1.58	
105	16.13	0.89	0.18	1.15	
120	14.56	0.81	0.10	0.69	

Proposed Nokia Ottawa Innovation Campus					
Novatech Project No. 123043					
REQUIRED STORAGE - 1:5 YEAR EVENT					
AREA A-6 Controlled Roof Drain #7					
OTTAWA IDF CURVE					
Area =	0.022	ha	Qallow =	0.79	L/s
C =	0.90		Vol(max) =	4.0	m ³
Time (min)	Intensity (mm/hr)	Q (L/s)	Qnet (L/s)	Vol (m ³)	
5	141.18	7.81	7.02	2.10	
10	104.19	5.76	4.97	2.98	
15	83.56	4.62	3.83	3.45	
20	70.25	3.88	3.09	3.71	
25	60.90	3.37	2.58	3.87	
30	53.93	2.98	2.19	3.95	
35	48.52	2.68	1.89	3.97	
40	44.18	2.44	1.65	3.97	
45	40.63	2.25	1.46	3.93	
50	37.65	2.08	1.29	3.88	
55	35.12	1.94	1.15	3.80	
60	32.94	1.82	1.03	3.71	
65	31.04	1.72	0.93	3.61	
70	29.37	1.62	0.83	3.50	
75	27.89	1.54	0.75	3.38	
90	24.29	1.34	0.55	2.99	
105	21.58	1.19	0.40	2.54	
120	19.47	1.08	0.29	2.06	

Watts Accutrol Flow Control Roof Drains: RD-100-A-ADJ set to 1/4 open					
Design Event	Flow/Drain (L/s)	Total Flow (L/s)	Storage (m ³)		
			Ponding (cm)	Required	Provided
1:2 Year	0.71	0.71	8	2.7	
1:5 Year	0.79	0.79	10	4.0	9.2
1:100 Year	0.95	0.95	15	9.0	

Roof Drain Storage Table for Area RD 7		
Elevation	Area RD 1	Total Volume
m	m ²	m ³
0.00	0	0
0.05	18.6	0.5
0.10	79.1	2.9
0.15	174.2	9.2

Proposed Nokia Ottawa Innovation Campus					
Novatech Project No. 123043					
REQUIRED STORAGE - 1:100 YEAR EVENT					
AREA A-6 Controlled Roof Drain #7					
OTTAWA IDF CURVE					
Area =	0.022	ha	Qallow =	0.95	L/s
C =	1.00		Vol(max) =	9.0	m ³
Time (min)	Intensity (mm/hr)	Q (L/s)	Qnet (L/s)	Vol (m ³)	
5	242.70	14.91	13.96	4.19	
10	178.56	10.97	10.02	6.01	
15	142.89	8.78	7.83	7.05	
20	119.95	7.37	6.42	7.70	
25	103.85	6.38	5.43	8.15	
30	91.87	5.64	4.69	8.45	
35	82.58	5.07	4.12	8.66	
40	75.15	4.62	3.67	8.80	
45	69.05	4.24	3.29	8.89	
50	63.95	3.93	2.98	8.94	
55	59.62	3.66	2.71	8.95	
60	55.89	3.43	2.48	8.94	
80	44.99	2.76	1.81	8.71	
100	37.90	2.33	1.38	8.27	
120	32.89	2.02	1.07	7.71	
140	29.15	1.79	0.84	7.06	
160	26.24	1.61	0.66	6.36	
180	23.90	1.47	0.52	5.60	

Proposed Nokia Ottawa Innovation Campus					
Novatech Project No. 123043					
REQUIRED STORAGE - 1:100 YEAR + 20%					
AREA A-6 Controlled Roof Drain #7					
OTTAWA IDF CURVE					
Area =	0.022	ha	Qallow =	0.95	L/s
C =	1.00		Vol(max) =	11.4	m ³
Time (min)	Intensity (mm/hr)	Q (L/s)	Qnet (L/s)	Vol (m ³)	
5	291.24	17.89	16.94	5.08	
10	214.27	13.16	12.21	7.33	
15	171.47	10.53	9.58	8.63	
20	143.94	8.84	7.89	9.47	
25	124.62	7.66	6.71	10.06	
30	110.24	6.77	5.82	10.48	
35	99.09	6.09	5.14	10.79	
40	90.17	5.54	4.59	11.02	
45	82.86	5.09	4.14	11.18	
50	76.74	4.72	3.77	11.30	
55	71.55	4.40	3.45	11.37	
60	67.07	4.12	3.17	11.42	
65	63.18	3.88	2.93	11.43	
70	59.75	3.67	2.72	11.43	
75	56.71	3.48	2.53	11.40	
90	49.33	3.03	2.08	11.24	
105	43.80	2.69	1.74	10.97	
120	39.47	2.43	1.48	10.62	

Stage Storage Curve: Area A-6
 Controlled Roof Drain #7

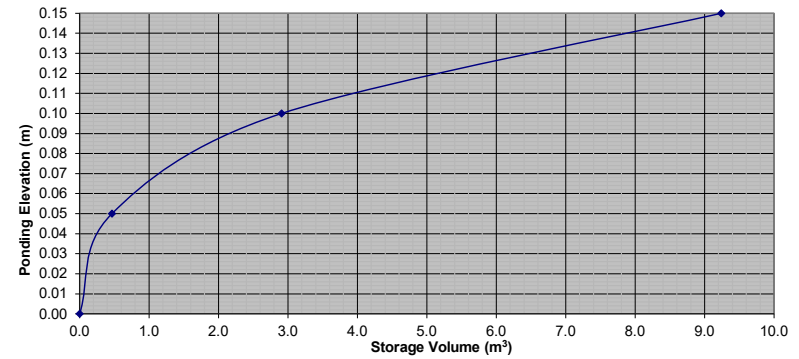

Proposed Nokia Ottawa Innovation Campus					
Novatech Project No. 123043					
REQUIRED STORAGE - 1:2 YEAR EVENT					
AREA A-6 Controlled Roof Drain #8					
OTTAWA IDF CURVE					
Area =	0.022	ha	Qallow =	0.71	L/s
C =	0.90		Vol(max) =	2.7	m ³
Time (min)	Intensity (mm/hr)	Q (L/s)	Qnet (L/s)	Vol (m ³)	
5	103.57	5.70	4.99	1.50	
10	76.81	4.23	3.52	2.11	
15	61.77	3.40	2.69	2.42	
20	52.03	2.86	2.15	2.58	
25	45.17	2.49	1.78	2.66	
30	40.04	2.20	1.49	2.69	
35	36.06	1.98	1.27	2.68	
40	32.86	1.81	1.10	2.64	
45	30.24	1.66	0.95	2.58	
50	28.04	1.54	0.83	2.50	
55	26.17	1.44	0.73	2.41	
60	24.56	1.35	0.64	2.31	
65	23.15	1.27	0.56	2.20	
70	21.91	1.21	0.50	2.08	
75	20.81	1.15	0.44	1.96	
90	18.14	1.00	0.29	1.56	
105	16.13	0.89	0.18	1.12	
120	14.56	0.80	0.09	0.66	

Proposed Nokia Ottawa Innovation Campus					
Novatech Project No. 123043					
REQUIRED STORAGE - 1:5 YEAR EVENT					
AREA A-6 Controlled Roof Drain #8					
OTTAWA IDF CURVE					
Area =	0.022	ha	Qallow =	0.79	L/s
C =	0.90		Vol(max) =	3.9	m ³
Time (min)	Intensity (mm/hr)	Q (L/s)	Qnet (L/s)	Vol (m ³)	
5	141.18	7.77	6.98	2.09	
10	104.19	5.74	4.95	2.97	
15	83.56	4.60	3.81	3.43	
20	70.25	3.87	3.08	3.69	
25	60.90	3.35	2.56	3.84	
30	53.93	2.97	2.18	3.92	
35	48.52	2.67	1.88	3.95	
40	44.18	2.43	1.64	3.94	
45	40.63	2.24	1.45	3.91	
50	37.65	2.07	1.28	3.85	
55	35.12	1.93	1.14	3.77	
60	32.94	1.81	1.02	3.68	
65	31.04	1.71	0.92	3.58	
70	29.37	1.62	0.83	3.47	
75	27.89	1.54	0.75	3.35	
90	24.29	1.34	0.55	2.95	
105	21.58	1.19	0.40	2.51	
120	19.47	1.07	0.28	2.03	

Watts Accutrol Flow Control Roof Drains: RD-100-A-ADJ set to 1/4 open					
Design Event	Flow/Drain (L/s)	Total Flow (L/s)	Ponding (cm)	Required Storage (m ³)	Provided
1:2 Year	0.71	0.71	8	2.7	
1:5 Year	0.79	0.79	10	3.9	9.3
1:100 Year	0.95	0.95	15	8.9	

Roof Drain Storage Table for Area RD 8		
Elevation	Area RD 1	Total Volume
m	m ²	m ³
0.00	0	0
0.05	18.7	0.5
0.10	79.3	2.9
0.15	176.1	9.3

Proposed Nokia Ottawa Innovation Campus					
Novatech Project No. 123043					
REQUIRED STORAGE - 1:100 YEAR EVENT					
AREA A-6 Controlled Roof Drain #8					
OTTAWA IDF CURVE					
Area =	0.022	ha	Qallow =	0.95	L/s
C =	1.00		Vol(max) =	8.9	m ³
Time (min)	Intensity (mm/hr)	Q (L/s)	Qnet (L/s)	Vol (m ³)	
5	242.70	14.84	13.89	4.17	
10	178.56	10.92	9.97	5.98	
15	142.89	8.74	7.79	7.01	
20	119.95	7.34	6.39	7.66	
25	103.85	6.35	5.40	8.10	
30	91.87	5.62	4.67	8.40	
35	82.58	5.05	4.10	8.61	
40	75.15	4.60	3.65	8.75	
45	69.05	4.22	3.27	8.84	
50	63.95	3.91	2.96	8.88	
55	59.62	3.65	2.70	8.90	
60	55.89	3.42	2.47	8.89	
80	44.99	2.75	1.80	8.65	
100	37.90	2.32	1.37	8.21	
120	32.89	2.01	1.06	7.65	
140	29.15	1.78	0.83	7.00	
160	26.24	1.60	0.65	6.29	
180	23.90	1.46	0.51	5.53	

Proposed Nokia Ottawa Innovation Campus					
Novatech Project No. 123043					
REQUIRED STORAGE - 1:100 YEAR + 20%					
AREA A-6 Controlled Roof Drain #8					
OTTAWA IDF CURVE					
Area =	0.022	ha	Qallow =	0.95	L/s
C =	1.00		Vol(max) =	11.4	m ³
Time (min)	Intensity (mm/hr)	Q (L/s)	Qnet (L/s)	Vol (m ³)	
5	291.24	17.81	16.86	5.06	
10	214.27	13.10	12.15	7.29	
15	171.47	10.49	9.54	8.58	
20	143.94	8.80	7.85	9.42	
25	124.62	7.62	6.67	10.01	
30	110.24	6.74	5.79	10.43	
35	99.09	6.06	5.11	10.73	
40	90.17	5.52	4.57	10.96	
45	82.86	5.07	4.12	11.12	
50	76.74	4.69	3.74	11.23	
55	71.55	4.38	3.43	11.31	
60	67.07	4.10	3.15	11.35	
65	63.18	3.86	2.91	11.36	
70	59.75	3.65	2.70	11.36	
75	56.71	3.47	2.52	11.33	
90	49.33	3.02	2.07	11.16	
105	43.80	2.68	1.73	10.89	
120	39.47	2.41	1.46	10.54	

Stage Storage Curve: Area A-6
 Controlled Roof Drain #8

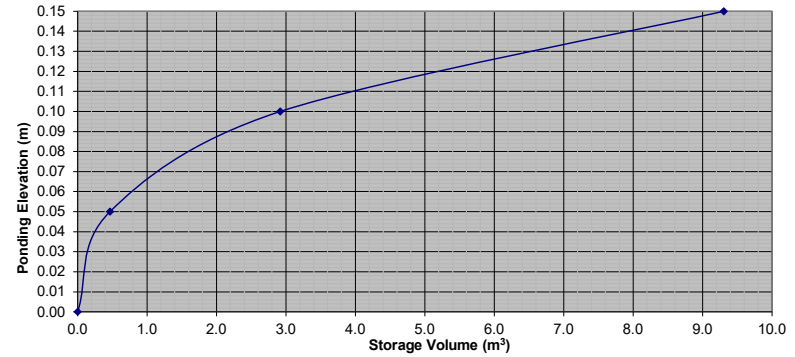

Proposed Nokia Ottawa Innovation Campus					
Novatech Project No. 123043					
Uncontrolled Runoff - 1:2 YEAR EVENT					
AREA B-0a Un-Controlled Runoff - Legget Drive					
OTTAWA IDF CURVE					
Area = 0.038 ha		Qallow = 2.0 L/s			
C = 0.25		Vol(max) = 0.0 m3			
Time (min)	Intensity (mm/hr)	Q (L/s)	Qnet (L/s)	Vol (m3)	
5	103.57	2.72	0.70	0.21	
10	76.81	2.02	0.00	0.00	
15	61.77	1.62	-0.39	-0.36	
20	52.03	1.37	-0.65	-0.78	
25	45.17	1.19	-0.83	-1.25	
30	40.04	1.05	-0.96	-1.74	
35	36.06	0.95	-1.07	-2.25	
40	32.86	0.86	-1.15	-2.77	
45	30.24	0.79	-1.22	-3.30	
50	28.04	0.74	-1.28	-3.84	
55	26.17	0.69	-1.33	-4.39	
60	24.56	0.64	-1.37	-4.94	
65	23.15	0.61	-1.41	-5.49	
70	21.91	0.58	-1.44	-6.05	
75	20.81	0.55	-1.47	-6.61	
90	18.14	0.48	-1.54	-8.31	
105	16.13	0.42	-1.59	-10.03	
120	14.56	0.38	-1.63	-11.76	
135	13.30	0.35	-1.67	-13.50	
150	12.25	0.32	-1.69	-15.25	

Proposed Nokia Ottawa Innovation Campus					
Novatech Project No. 123043					
Uncontrolled Runoff - 1:5 YEAR EVENT					
AREA B-0a Un-Controlled Runoff - Legget Drive					
OTTAWA IDF CURVE					
Area = 0.038 ha		Qallow = 2.7 L/s			
C = 0.25		Vol(max) = 0.0 m3			
Time (min)	Intensity (mm/hr)	Q (L/s)	Qnet (L/s)	Vol (m3)	
5	141.18	3.71	0.97	0.29	
10	104.19	2.73	0.00	0.00	
15	83.56	2.19	-0.54	-0.49	
20	70.25	1.84	-0.89	-1.07	
25	60.90	1.60	-1.14	-1.70	
30	53.93	1.42	-1.32	-2.37	
35	48.52	1.27	-1.46	-3.07	
40	44.18	1.16	-1.58	-3.78	
45	40.63	1.07	-1.67	-4.50	
50	37.65	0.99	-1.75	-5.24	
55	35.12	0.92	-1.81	-5.98	
60	32.94	0.86	-1.87	-6.73	
65	31.04	0.81	-1.92	-7.49	
70	29.37	0.77	-1.96	-8.25	
75	27.89	0.73	-2.00	-9.01	
90	24.29	0.64	-2.10	-11.33	
105	21.58	0.57	-2.17	-13.66	
120	19.47	0.51	-2.22	-16.01	
135	17.76	0.47	-2.27	-18.37	
150	16.36	0.43	-2.31	-20.75	

Proposed Nokia Ottawa Innovation Campus					
Novatech Project No. 123043					
Uncontrolled Runoff - 1:100 YEAR EVENT					
AREA B-0a Un-Controlled Runoff - Legget Drive					
OTTAWA IDF CURVE					
Area = 0.038 ha		Qallow = 5.7 L/s			
C = 0.30		Vol(max) = 0.0 m3			
Time (min)	Intensity (mm/hr)	Q (L/s)	Qnet (L/s)	Vol (m3)	
5	242.70	7.75	2.05	0.61	
10	178.56	5.70	0.00	0.00	
15	142.89	4.56	-1.14	-1.03	
20	119.95	3.83	-1.87	-2.25	
25	103.85	3.32	-2.39	-3.58	
30	91.87	2.93	-2.77	-4.98	
35	82.58	2.64	-3.07	-6.44	
40	75.15	2.40	-3.30	-7.93	
45	69.05	2.21	-3.50	-9.44	
50	63.95	2.04	-3.66	-10.98	
55	59.62	1.90	-3.80	-12.54	
60	55.89	1.79	-3.92	-14.10	
65	52.65	1.68	-4.02	-15.68	
70	49.79	1.59	-4.11	-17.27	
75	47.26	1.51	-4.19	-18.87	
90	41.11	1.31	-4.39	-23.71	
105	36.50	1.17	-4.54	-28.59	
120	32.89	1.05	-4.65	-33.50	
135	30.00	0.96	-4.75	-38.43	
150	27.61	0.88	-4.82	-43.39	

Proposed Nokia Ottawa Innovation Campus					
Novatech Project No. 123043					
Uncontrolled Runoff - 1:100 YR + 20% IDF Increase					
AREA B-0a Un-Controlled Runoff - Legget Drive					
OTTAWA IDF CURVE					
Area = 0.038 ha		Qallow = 6.8 L/s			
C = 0.30		Vol(max) = 0.0 m3			
Time (min)	Intensity (mm/hr)	Q (L/s)	Qnet (L/s)	Vol (m3)	
5	291.24	9.30	2.46	0.74	
10	214.27	6.84	0.00	0.00	
15	171.47	5.48	-1.37	-1.23	
20	143.94	4.60	-2.25	-2.70	
25	124.62	3.98	-2.86	-4.30	
30	110.24	3.52	-3.32	-5.98	
35	99.09	3.17	-3.68	-7.73	
40	90.17	2.88	-3.96	-9.51	
45	82.86	2.65	-4.20	-11.33	
50	76.74	2.45	-4.39	-13.18	
55	71.55	2.29	-4.56	-15.04	
60	67.07	2.14	-4.70	-16.93	
65	63.18	2.02	-4.83	-18.82	
70	59.75	1.91	-4.94	-20.73	
75	56.71	1.81	-5.03	-22.65	
90	49.33	1.58	-5.27	-28.45	
105	43.80	1.40	-5.44	-34.30	
120	39.47	1.26	-5.58	-40.20	
135	36.00	1.15	-5.69	-46.12	
150	33.13	1.06	-5.79	-52.07	

Proposed Nokia Ottawa Innovation Campus Novatech Project No. 123043 Uncontrolled Runoff - 1:2 YEAR EVENT AREA B-0b Un-Controlled Runoff - Access Route					
OTTAWA IDF CURVE					
Area = 0.071 ha		Qallow = 3.7 L/s			
C = 0.25		Vol(max) = 0.0 m3			
Time (min)	Intensity (mm/hr)	Q (L/s)	Qnet (L/s)	Vol (m3)	
5	103.57	5.03	1.30	0.39	
10	76.81	3.73	0.00	0.00	
15	61.77	3.00	-0.73	-0.66	
20	52.03	2.53	-1.20	-1.44	
25	45.17	2.19	-1.54	-2.31	
30	40.04	1.95	-1.79	-3.21	
35	36.06	1.75	-1.98	-4.16	
40	32.86	1.60	-2.13	-5.12	
45	30.24	1.47	-2.26	-6.11	
50	28.04	1.36	-2.37	-7.11	
55	26.17	1.27	-2.46	-8.12	
60	24.56	1.19	-2.54	-9.14	
65	23.15	1.12	-2.61	-10.16	
70	21.91	1.06	-2.67	-11.20	
75	20.81	1.01	-2.72	-12.24	
90	18.14	0.88	-2.85	-15.39	
105	16.13	0.78	-2.95	-18.57	
120	14.56	0.71	-3.02	-21.77	
135	13.30	0.65	-3.08	-24.99	
150	12.25	0.60	-3.14	-28.22	

Proposed Nokia Ottawa Innovation Campus Novatech Project No. 123043 Uncontrolled Runoff - 1:5 YEAR EVENT AREA B-0b Un-Controlled Runoff - Access Route					
OTTAWA IDF CURVE					
Area = 0.071 ha		Qallow = 5.1 L/s			
C = 0.25		Vol(max) = 0.0 m3			
Time (min)	Intensity (mm/hr)	Q (L/s)	Qnet (L/s)	Vol (m3)	
5	141.18	6.86	1.80	0.54	
10	104.19	5.06	0.00	0.00	
15	83.56	4.06	-1.00	-0.90	
20	70.25	3.41	-1.65	-1.98	
25	60.90	2.96	-2.10	-3.15	
30	53.93	2.62	-2.44	-4.39	
35	48.52	2.36	-2.70	-5.68	
40	44.18	2.15	-2.91	-7.00	
45	40.63	1.97	-3.09	-8.34	
50	37.65	1.83	-3.23	-9.70	
55	35.12	1.71	-3.35	-11.07	
60	32.94	1.60	-3.46	-12.46	
65	31.04	1.51	-3.55	-13.86	
70	29.37	1.43	-3.63	-15.26	
75	27.89	1.35	-3.71	-16.68	
90	24.29	1.18	-3.88	-20.96	
105	21.58	1.05	-4.01	-25.28	
120	19.47	0.95	-4.12	-29.63	
135	17.76	0.86	-4.20	-34.00	
150	16.36	0.79	-4.27	-38.40	

Proposed Nokia Ottawa Innovation Campus Novatech Project No. 123043 Uncontrolled Runoff - 1:100 YEAR EVENT AREA B-0b Un-Controlled Runoff - Access Route					
OTTAWA IDF CURVE					
Area = 0.071 ha		Qallow = 10.6 L/s			
C = 0.30		Vol(max) = 0.0 m3			
Time (min)	Intensity (mm/hr)	Q (L/s)	Qnet (L/s)	Vol (m3)	
5	242.70	14.35	3.79	1.14	
10	178.56	10.55	0.00	0.00	
15	142.89	8.45	-2.11	-1.90	
20	119.95	7.09	-3.46	-4.16	
25	103.85	6.14	-4.42	-6.62	
30	91.87	5.43	-5.12	-9.22	
35	82.58	4.88	-5.67	-11.91	
40	75.15	4.44	-6.11	-14.67	
45	69.05	4.08	-6.47	-17.48	
50	63.95	3.78	-6.77	-20.32	
55	59.62	3.52	-7.03	-23.20	
60	55.89	3.30	-7.25	-26.10	
65	52.65	3.11	-7.44	-29.03	
70	49.79	2.94	-7.61	-31.97	
75	47.26	2.79	-7.76	-34.93	
90	41.11	2.43	-8.12	-43.87	
105	36.50	2.16	-8.40	-52.90	
120	32.89	1.94	-8.61	-61.99	
135	30.00	1.77	-8.78	-71.13	
150	27.61	1.63	-8.92	-80.30	

Proposed Nokia Ottawa Innovation Campus Novatech Project No. 123043 Uncontrolled Runoff - 1:100 YR + 20% IDF Increase AREA B-0b Un-Controlled Runoff - Access Route					
OTTAWA IDF CURVE					
Area = 0.071 ha		Qallow = 12.7 L/s			
C = 0.30		Vol(max) = 0.0 m3			
Time (min)	Intensity (mm/hr)	Q (L/s)	Qnet (L/s)	Vol (m3)	
5	291.24	17.22	4.55	1.36	
10	214.27	12.67	0.00	0.00	
15	171.47	10.14	-2.53	-2.28	
20	143.94	8.51	-4.16	-4.99	
25	124.62	7.37	-5.30	-7.95	
30	110.24	6.52	-6.15	-11.07	
35	99.09	5.86	-6.81	-14.30	
40	90.17	5.33	-7.34	-17.60	
45	82.86	4.90	-7.77	-20.97	
50	76.74	4.54	-8.13	-24.39	
55	71.55	4.23	-8.44	-27.84	
60	67.07	3.96	-8.70	-31.32	
65	63.18	3.73	-8.93	-34.83	
70	59.75	3.53	-9.13	-38.36	
75	56.71	3.35	-9.31	-41.91	
90	49.33	2.92	-9.75	-52.65	
105	43.80	2.59	-10.08	-63.48	
120	39.47	2.33	-10.33	-74.39	
135	36.00	2.13	-10.54	-85.36	
150	33.13	1.96	-10.71	-96.36	

Proposed Nokia Development Storage Calculations Using Average
Novatech Project No. 123043 Release Rate Equal to 50% of the Qpeak
REQUIRED STORAGE - 1:2 YEAR EVENT

AREA B-1 Controlled Site Flows (R&D Lab Internal SWM Tank)

OTTAWA IDF CURVE Qpeak = 21.9 L/s
 Area = 0.795 ha Qavg = 11.0 L/s
 C = 0.90 Vol(max) = 137.1 m3
 (Vol calculated for Qallow-avg)

Time (min)	Tributary Ar (mm/hr)	Q (L/s)	Qnet (L/s)	Vol (m3)
5	103.57	206.02	195.07	58.52
10	76.81	152.78	141.83	85.10
15	61.77	122.86	111.91	100.72
20	52.03	103.50	92.55	111.06
25	45.17	89.84	78.89	118.34
30	40.04	79.65	68.70	123.66
35	36.06	71.73	60.78	127.63
40	32.86	65.37	54.42	130.61
45	30.24	60.15	49.20	132.84
50	28.04	55.78	44.83	134.48
55	26.17	52.06	41.11	135.65
60	24.56	48.85	37.90	136.44
65	23.15	46.05	35.10	136.89
70	21.91	43.59	32.64	137.08
75	20.81	41.40	30.45	137.03
90	18.14	36.09	25.14	135.75
105	16.13	32.09	21.14	133.20
120	14.56	28.97	18.02	129.71
135	13.30	26.45	15.50	125.53
150	12.25	24.37	13.42	120.78

Proposed Nokia Development Storage Calculations Using Average
Novatech Project No. 123043 Release Rate Equal to 50% of the Qpeak
REQUIRED STORAGE - 1:5 YEAR EVENT

AREA B-1 Controlled Site Flows (R&D Lab Internal SWM Tank)

OTTAWA IDF CURVE Qpeak = 27.2 L/s
 Area = 0.795 ha Qavg = 13.6 L/s
 C = 0.90 Vol(max) = 188.4 m3
 (Vol calculated for Qallow-avg)

Time (min)	Intensity (mm/hr)	Q (L/s)	Qnet (L/s)	Vol (m3)
5	141.18	280.83	267.23	80.17
10	104.19	207.26	193.66	116.19
15	83.56	166.21	152.61	137.35
20	70.25	139.74	126.14	151.37
25	60.90	121.13	107.53	161.30
30	53.93	107.27	93.67	168.61
35	48.52	96.51	82.91	174.11
40	44.18	87.89	74.29	178.29
45	40.63	80.82	67.22	181.48
50	37.65	74.90	61.30	183.89
55	35.12	69.87	56.27	185.68
60	32.94	65.53	51.93	186.95
65	31.04	61.75	48.15	187.79
70	29.37	58.43	44.83	188.27
75	27.89	55.47	41.87	188.43
90	24.29	48.31	34.71	187.45
105	21.58	42.93	29.33	184.78
120	19.47	38.72	25.12	180.89
135	17.76	35.34	21.74	176.07
150	16.36	32.55	18.95	170.52

Proposed Nokia Development Storage Calculations Using Average
Novatech Project No. 123043 Release Rate Equal to 50% of the Qpeak
REQUIRED STORAGE - 1:100 YEAR EVENT

AREA B-1 Controlled Site Flows (R&D Lab Internal SWM Tank)

OTTAWA IDF CURVE Qpeak = 41.0 L/s
 Area = 0.795 ha Qavg = 20.5 L/s
 C = 1.00 Vol(max) = 380.0 m3
 (Vol calculated for Qallow-avg)

Time (min)	Intensity (mm/hr)	Q (L/s)	Qnet (L/s)	Vol (m3)
5	242.70	536.42	515.92	154.77
10	178.56	394.65	374.15	224.49
15	142.89	315.82	295.32	265.79
20	119.95	265.11	244.61	293.53
25	103.85	229.52	209.02	313.53
30	91.87	203.04	182.54	328.58
35	82.58	182.51	162.01	340.23
40	75.15	166.08	145.58	349.40
45	69.05	152.61	132.11	356.71
50	63.95	141.35	120.85	362.55
55	59.62	131.78	111.28	367.22
60	55.89	123.54	103.04	370.93
65	52.65	116.36	95.86	373.84
70	49.79	110.04	89.54	376.08
75	47.26	104.44	83.94	377.74
90	41.11	90.86	70.36	379.96
105	36.50	80.67	60.17	379.04
120	32.89	72.70	52.20	375.86
135	30.00	66.30	45.80	370.97
150	27.61	61.02	40.52	364.72

Proposed Nokia Development Storage Calculations Using Average
Novatech Project No. 123043 Release Rate Equal to 50% of the Qpeak
REQUIRED STORAGE - 1:100 YR + 20% IDF Increase

AREA B-1 Controlled Site Flows (R&D Lab Internal SWM Tank)

OTTAWA IDF CURVE Qpeak = 41.0 L/s
 Area = 0.795 ha Qavg = 20.5 L/s
 C = 1.00 Vol(max) = 480.7 m3
 (Vol calculated for Qallow-avg)

Time (min)	Intensity (mm/hr)	Q (L/s)	Qnet (L/s)	Vol (m3)
5	291.24	643.70	623.20	186.96
10	214.27	473.57	453.07	271.84
15	171.47	378.98	358.48	322.64
20	143.94	318.13	297.63	357.16
25	124.62	275.42	254.92	382.38
30	110.24	243.65	223.15	401.68
35	99.09	219.01	198.51	416.88
40	90.17	199.30	178.80	429.12
45	82.86	183.14	162.64	439.12
50	76.74	169.62	149.12	447.36
55	71.55	158.13	137.63	454.19
60	67.07	148.24	127.74	459.88
65	63.18	139.63	119.13	464.60
70	59.75	132.05	111.55	468.52
75	56.71	125.33	104.83	471.74
90	49.33	109.03	88.53	478.09
105	43.80	96.80	76.30	480.68
120	39.47	87.24	66.74	480.56
135	36.00	79.56	59.06	478.37
150	33.13	73.23	52.73	474.56

Structures	Size (mm)	Area (m ²)	T/G	Inv IN	Inv OUT
SWM TANK	1000	400.00	79.80		77.90
CBMH 266	1200	1.13	79.78	77.89	77.86
-	-	-	-	-	-

PI = 3.141592654
 PIPE I.D. = 457.2 PVC
U/G Storage Pipe Volume
 End Area 0.164 (m²)
 Total Length 1.0 (m)
 Pipe Volume 0.2 (m³)

Area B-1: Storage Table					Underground Storage	Surface Storage						Total Storage		
Elevation (m)	System Depth (m)	SWM TANK Volume (m ³)	CBMH 266 Volume (m ³)	-	Combined Volume (m ³)	SWM TANK		CBMH 266		-		Ponding Volume (m ³)	Total Volume (m ³)	Design Head
						Area (m ²)	Volume (m ³)	Area (m ²)	Volume (m ³)	Area (m ²)	Volume (m ³)			
77.86	0.00	0.00	0.00	-	0.16	-	-	-	-	-	-	-	0	-
78.25	0.35	140.00	0.44	-	140.61	-	-	-	-	-	-	-	140.6	0.24
78.38	0.48	192.00	0.59	-	192.75	-	-	-	-	-	-	-	192.8	0.37
78.86	0.96	384.00	1.13	-	385.30	-	-	-	-	-	-	-	385.3	0.85
78.91	1.01	404.00	1.19	-	405.35	-	-	-	-	-	-	-	405.4	0.90
80.08	2.18	404.00	2.51	-	406.67	0.0	0.0	0.0	0.0	0.0	0.0	0.0	406.7	2.07
80.13						0.00	0.00	0.00	0.00	0.00	0.00	0.0	406.7	2.12
80.18						0.00	0.00	0.00	0.00	0.00	0.00	0.0	406.7	2.17
80.23						0.00	0.00	0.00	0.00	0.00	0.00	0.0	406.7	2.22

Tempest HF Type C ICD	
1:100 Yr	
Flow (L/s) = 41.0	Head (m) = 0.85
Elevation (m) = 78.86	Outlet Pipe Dia.(mm) = 301
Volume (m3) = 380.0	
1:5 Yr	
Flow (L/s) = 27.2	Head (m) = 0.37
Elevation (m) = 78.38	Outlet Pipe Dia.(mm) = 301
Volume (m3) = 188.4	
1:2 Yr	
Flow (L/s) = 21.9	Head (m) = 0.24
Elevation (m) = 78.25	Outlet Pipe Dia.(mm) = 301
Volume (m3) = 137.1	

Orifice Size - 1:100 yr Flow Check		
$Q=0.62 \times A \times (2gh)^{0.5}$		
	1:100 yr	Flow Check
Q (m ³ /s) =	0.0410	0.0412
g (m/s ²) =	9.81	9.81
h (m) =	0.85	0.85
A (m ²) =	0.016197984	0.01629
D (m) =	0.143610286	0.14400
D (mm) =	144	144.0

1:5 yr Flow Check	
	1:5 yr
Q (m ³ /s) =	0.0272
g (m/s ²) =	9.81
h (m) =	0.37
A (m ²) =	0.01629
D (m) =	0.144
D (mm) =	144

1:2 yr Flow Check	
	1:2 yr
Q (m ³ /s) =	0.0219
g (m/s ²) =	9.81
h (m) =	0.24
A (m ²) =	0.01629
D (m) =	0.144
D (mm) =	144

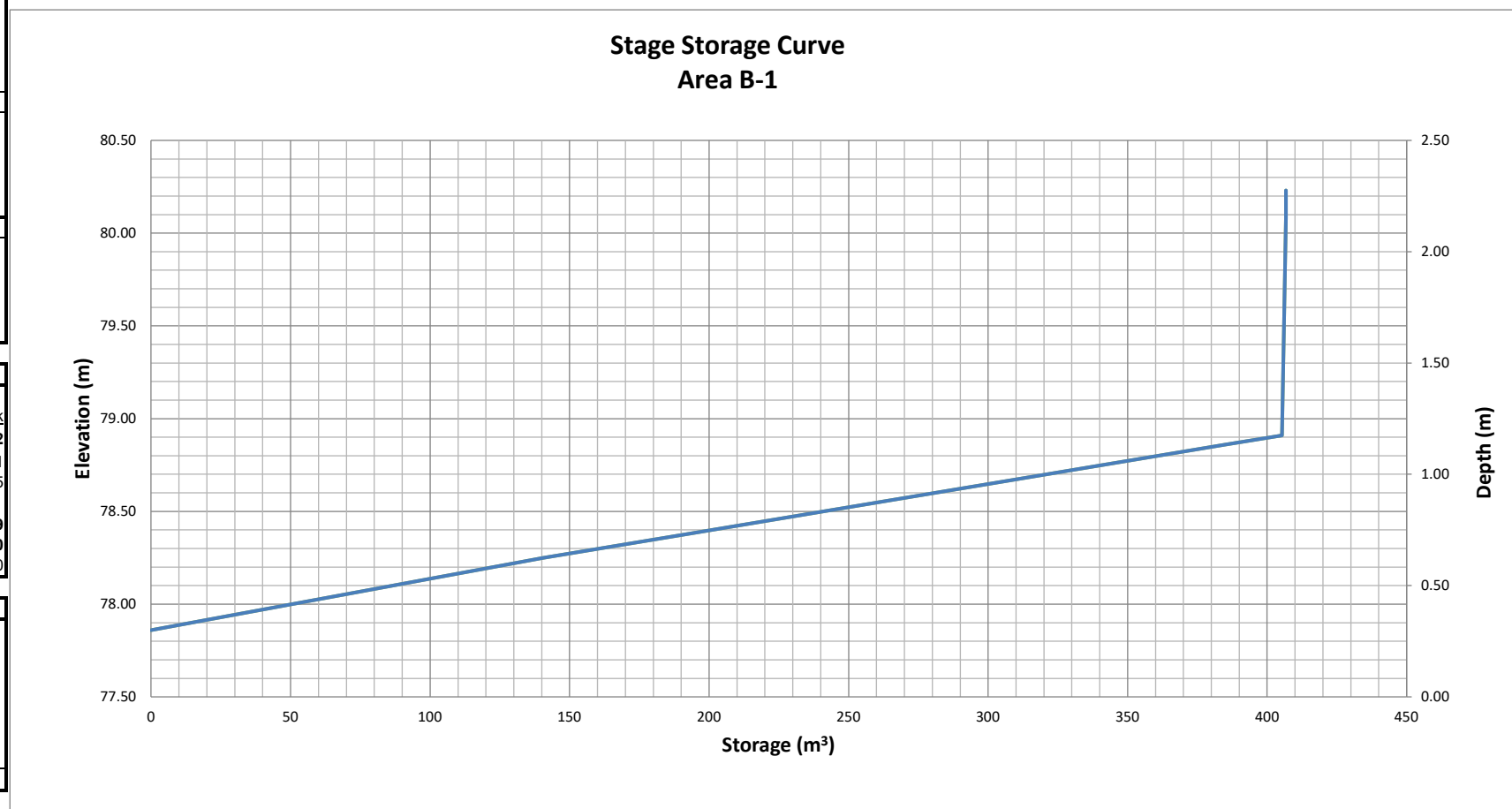

Proposed Nokia Development Storage Calculations Using Average
Novatech Project No. 123043 Release Rate Equal to 50% of the Qpeak
REQUIRED STORAGE - 1:2 YEAR EVENT

AREA B-2 Controlled Site Flows (Plaza & Entrance Dropoff)

OTTAWA IDF CURVE Qpeak = 31.9 L/s
 Area = 0.584 ha Qavg = 16.0 L/s
 C = 0.66 Vol(max) = 48.3 m3
 (Vol calculated for Qallow-avg)

Time (min)	Tributary Ar (mm/hr)	Q (L/s)	Qnet (L/s)	Vol (m3)
5	103.57	110.36	94.41	28.32
10	76.81	81.84	65.89	39.53
15	61.77	65.82	49.87	44.88
20	52.03	55.44	39.49	47.39
25	45.17	48.13	32.18	48.27
30	40.04	42.67	26.72	48.09
35	36.06	38.42	22.47	47.19
40	32.86	35.02	19.07	45.77
45	30.24	32.22	16.27	43.93
50	28.04	29.88	13.93	41.79
55	26.17	27.89	11.94	39.39
60	24.56	26.17	10.22	36.78
65	23.15	24.67	8.72	34.00
70	21.91	23.35	7.40	31.08
75	20.81	22.18	6.23	28.02
90	18.14	19.33	3.38	18.26
105	16.13	17.19	1.24	7.82
120	14.56	15.52	-0.43	-3.12
135	13.30	14.17	-1.78	-14.44
150	12.25	13.05	-2.90	-26.06

Proposed Nokia Development Storage Calculations Using Average
Novatech Project No. 123043 Release Rate Equal to 50% of the Qpeak
REQUIRED STORAGE - 1:5 YEAR EVENT

AREA B-2 Controlled Site Flows (Plaza & Entrance Dropoff)

OTTAWA IDF CURVE Qpeak = 35.8 L/s
 Area = 0.584 ha Qavg = 17.9 L/s
 C = 0.66 Vol(max) = 71.2 m3
 (Vol calculated for Qallow-avg)

Time (min)	Intensity (mm/hr)	Q (L/s)	Qnet (L/s)	Vol (m3)
5	141.18	150.43	132.53	39.76
10	104.19	111.02	93.12	55.87
15	83.56	89.04	71.14	64.02
20	70.25	74.86	56.96	68.35
25	60.90	64.89	46.99	70.48
30	53.93	57.46	39.56	71.21
35	48.52	51.70	33.80	70.98
40	44.18	47.08	29.18	70.03
45	40.63	43.29	25.39	68.56
50	37.65	40.12	22.22	66.67
55	35.12	37.43	19.53	64.44
60	32.94	35.10	17.20	61.93
65	31.04	33.08	15.18	59.20
70	29.37	31.30	13.40	56.27
75	27.89	29.72	11.82	53.18
90	24.29	25.88	7.98	43.10
105	21.58	23.00	5.10	32.11
120	19.47	20.74	2.84	20.48
135	17.76	18.93	1.03	8.34
150	16.36	17.43	-0.47	-4.19

Proposed Nokia Development Storage Calculations Using Average
Novatech Project No. 123043 Release Rate Equal to 50% of the Qpeak
REQUIRED STORAGE - 1:100 YEAR EVENT

AREA B-2 Controlled Site Flows (Plaza & Entrance Dropoff)

OTTAWA IDF CURVE Qpeak = 48.0 L/s
 Area = 0.584 ha Qavg = 24.0 L/s
 C = 0.74 Vol(max) = 159.1 m3
 (Vol calculated for Qallow-avg)

Time (min)	Intensity (mm/hr)	Q (L/s)	Qnet (L/s)	Vol (m3)
5	242.70	291.51	267.51	80.25
10	178.56	214.47	190.47	114.28
15	142.89	171.63	147.63	132.87
20	119.95	144.07	120.07	144.09
25	103.85	124.73	100.73	151.10
30	91.87	110.34	86.34	155.42
35	82.58	99.19	75.19	157.89
40	75.15	90.26	66.26	159.02
45	69.05	82.94	58.94	159.13
50	63.95	76.82	52.82	158.45
55	59.62	71.61	47.61	157.13
60	55.89	67.14	43.14	155.29
65	52.65	63.23	39.23	153.01
70	49.79	59.80	35.80	150.37
75	47.26	56.76	32.76	147.41
90	41.11	49.38	25.38	137.04
105	36.50	43.84	19.84	124.97
120	32.89	39.51	15.51	111.67
135	30.00	36.03	12.03	97.44
150	27.61	33.16	9.16	82.47

Proposed Nokia Development Storage Calculations Using Average
Novatech Project No. 123043 Release Rate Equal to 50% of the Qpeak
REQUIRED STORAGE - 1:100 YR + 20% IDF Increase

AREA B-2 Controlled Site Flows (Plaza & Entrance Dropoff)

OTTAWA IDF CURVE Qpeak = 48.0 L/s
 Area = 0.584 ha Qavg = 24.0 L/s
 C = 0.74 Vol(max) = 204.5 m3
 (Vol calculated for Qallow-avg)

Time (min)	Intensity (mm/hr)	Q (L/s)	Qnet (L/s)	Vol (m3)
5	291.24	349.82	325.82	97.74
10	214.27	257.36	233.36	140.02
15	171.47	205.96	181.96	163.76
20	143.94	172.89	148.89	178.67
25	124.62	149.68	125.68	188.52
30	110.24	132.41	108.41	195.14
35	99.09	119.02	95.02	199.55
40	90.17	108.31	84.31	202.34
45	82.86	99.52	75.52	203.92
50	76.74	92.18	68.18	204.54
55	71.55	85.94	61.94	204.39
60	67.07	80.56	56.56	203.62
65	63.18	75.88	51.88	202.34
70	59.75	71.76	47.76	200.60
75	56.71	68.11	44.11	198.50
90	49.33	59.25	35.25	190.37
105	43.80	52.60	28.60	180.21
120	39.47	47.41	23.41	168.57
135	36.00	43.24	19.24	155.81
150	33.13	39.80	15.80	142.16

Structures	Size (mm)	Area (m ²)	T/G	Inv IN	Inv OUT
UG STORAGE	1144	112.10	82.10		79.58
CMBH 254-259	1200	7.92	82.04	79.54	79.14
CBMH 260	1200	1.13	81.15	78.93	78.90

PI = 3.141592654
 PIPE I.D. = 304.2 PVC
U/G Storage Pipe Volume
 End Area 0.073 (m²)
 Total Length 230.7 (m)
 Pipe Volume 16.8 (m³)

Area B-2: Storage Table					Underground Storage	Surface Storage						Total Storage		
Elevation (m)	System Depth (m)	UG STORAGE Volume (m ³)	CMBH 254-259 Volume (m ³)	CBMH 260 Volume (m ³)	Combined Volume (m ³)	UG STORAGE		CMBH 254-259		CBMH 260		Ponding Volume (m ³)	Total Volume (m ³)	Design Head
						Area (m ²)	Volume (m ³)	Area (m ²)	Volume (m ³)	Area (m ²)	Volume (m ³)			
78.90	0.00	0.00	0.00	0.00	16.77	-	-	-	-	-	-	-	0	-
79.81	0.23	25.78	5.30	1.03	48.88	-	-	-	-	-	-	-	48.9	0.72
80.00	0.42	47.08	6.81	1.24	71.90	-	-	-	-	-	-	-	71.9	0.91
80.72	1.14	127.80	12.51	2.06	159.13	-	-	-	-	-	-	-	159.1	1.63
80.73	1.15	128.92	12.59	2.07	160.34	-	-	-	-	-	-	-	160.3	1.64
81.15	1.57	128.92	15.91	2.54	164.14	0.0	0.0	0.0	0.0	0.0	0.0	0.0	164.1	2.06
81.20						0.00	0.00	0.00	0.00	0.00	0.00	0.0	164.1	2.11
81.25						0.00	0.00	0.00	0.00	0.00	0.00	0.0	164.1	2.16
81.30						0.00	0.00	0.00	0.00	0.00	0.00	0.0	164.1	2.21

Tempest HF Type D ICD	
1:100 Yr	
Flow (L/s) = 48.0	Head (m) = 1.64
Elevation (m) = 80.73	Outlet Pipe Dia.(mm) = 382
Volume (m3) = 159.1	
1:5 Yr	
Flow (L/s) = 35.8	Head (m) = 0.91
Elevation (m) = 80.00	Outlet Pipe Dia.(mm) = 382
Volume (m3) = 71.2	
1:2 Yr	
Flow (L/s) = 31.9	Head (m) = 0.72
Elevation (m) = 79.81	Outlet Pipe Dia.(mm) = 382
Volume (m3) = 48.3	

Orifice Size - 1:100 yr Flow Check		
$Q=0.62 \times A \times (2gh)^{0.5}$		
	1:100 yr	Flow Check
Q (m ³ /s) =	0.0480	0.0481
g (m/s ²) =	9.81	9.81
h (m) =	1.64	1.64
A (m ²) =	0.013652449	0.01368
D (m) =	0.131843992	0.13200
D (mm) =	132	132.0

1:5 yr Flow Check	
	1:5 yr
Q (m ³ /s) =	0.0358
g (m/s ²) =	9.81
h (m) =	0.91
A (m ²) =	0.01368
D (m) =	0.132
D (mm) =	132

1:2 yr Flow Check	
	1:2 yr
Q (m ³ /s) =	0.0319
g (m/s ²) =	9.81
h (m) =	0.72
A (m ²) =	0.01368
D (m) =	0.132
D (mm) =	132

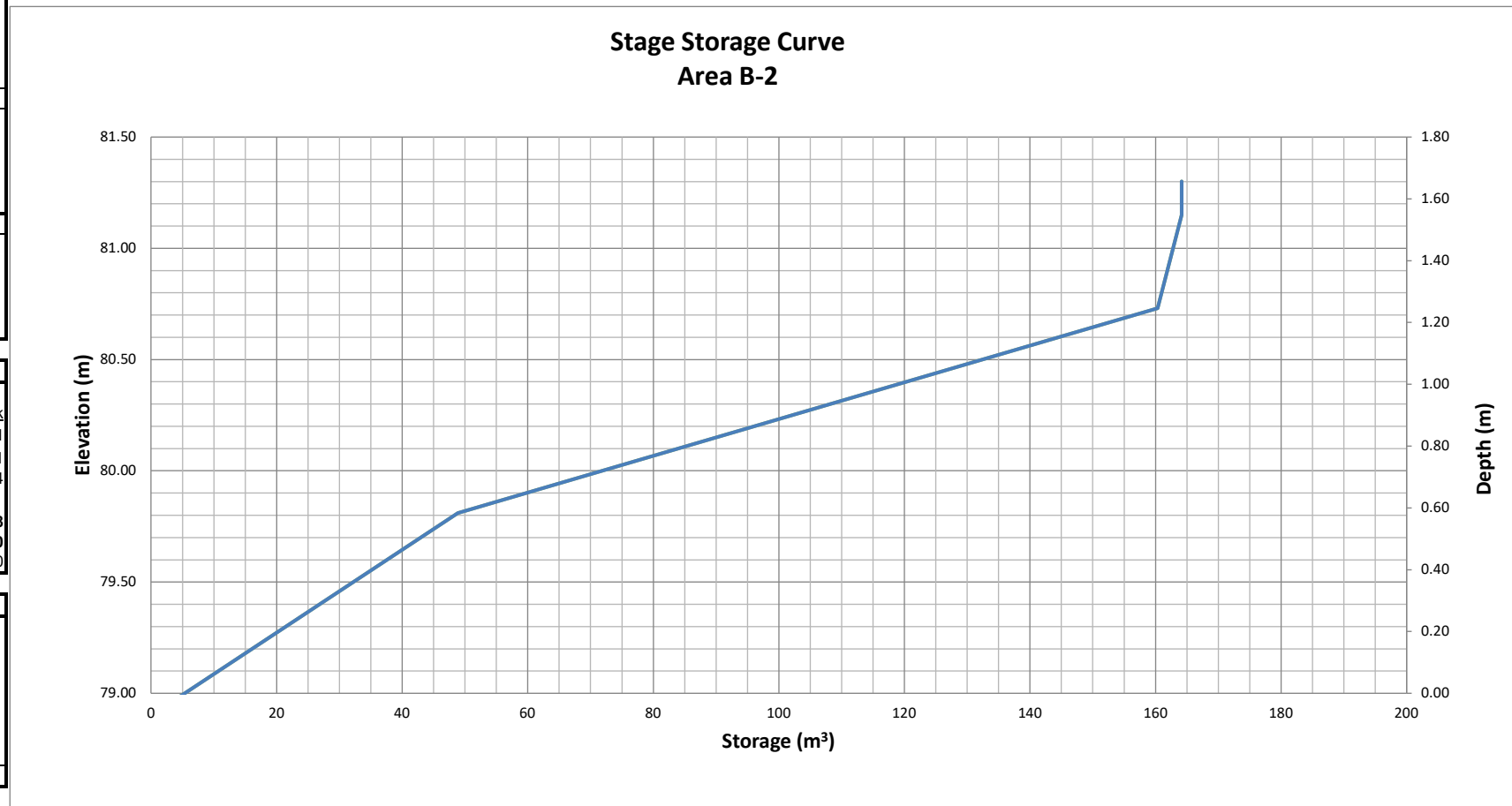

Proposed Nokia Development		Storage Calculations Using Average		
Novatech Project No. 123043		Release Rate Equal to 50% of the Qpeak		
REQUIRED STORAGE - 1:2 YEAR EVENT				
AREA B-3 Controlled Site Flows (Parking Structure)				
OTTAWA IDF CURVE		Qpeak =	23.7	L/s
Area =	1.187 ha	Qavg =	11.9	L/s
C =	0.89	Vol(max) =	222.2	m3
(Vol calculated for Qallow-avg)				
Time (min)	Tributary Ar (mm/hr)	Q (L/s)	Qnet (L/s)	Vol (m3)
5	103.57	302.53	290.68	87.21
10	76.81	224.35	212.50	127.50
15	61.77	180.42	168.57	151.72
20	52.03	151.98	140.13	168.16
25	45.17	131.93	120.08	180.13
30	40.04	116.97	105.12	189.21
35	36.06	105.33	93.48	196.31
40	32.86	96.00	84.15	201.95
45	30.24	88.33	76.48	206.50
50	28.04	81.91	70.06	210.18
55	26.17	76.44	64.59	213.16
60	24.56	71.73	59.88	215.58
65	23.15	67.62	55.77	217.52
70	21.91	64.01	52.16	219.06
75	20.81	60.80	48.95	220.26
90	18.14	53.00	41.15	222.19
105	16.13	47.13	35.28	222.24
120	14.56	42.54	30.69	220.94
135	13.30	38.84	26.99	218.60
150	12.25	35.79	23.94	215.44

Proposed Nokia Development		Storage Calculations Using Average		
Novatech Project No. 123043		Release Rate Equal to 50% of the Qpeak		
REQUIRED STORAGE - 1:5 YEAR EVENT				
AREA B-3 Controlled Site Flows (Parking Structure)				
OTTAWA IDF CURVE		Qpeak =	29.8	L/s
Area =	1.187 ha	Qavg =	14.9	L/s
C =	0.89	Vol(max) =	303.3	m3
(Vol calculated for Qallow-avg)				
Time (min)	Intensity (mm/hr)	Q (L/s)	Qnet (L/s)	Vol (m3)
5	141.18	412.39	397.49	119.25
10	104.19	304.35	289.45	173.67
15	83.56	244.07	229.17	206.26
20	70.25	205.21	190.31	228.37
25	60.90	177.88	162.98	244.47
30	53.93	157.52	142.62	256.72
35	48.52	141.72	126.82	266.32
40	44.18	129.06	114.16	273.99
45	40.63	118.68	103.78	280.20
50	37.65	109.99	95.09	285.26
55	35.12	102.60	87.70	289.40
60	32.94	96.23	81.33	292.78
65	31.04	90.68	75.78	295.54
70	29.37	85.80	70.90	297.76
75	27.89	81.46	66.56	299.53
90	24.29	70.95	56.05	302.65
105	21.58	63.04	48.14	303.30
120	19.47	56.87	41.97	302.15
135	17.76	51.89	36.99	299.63
150	16.36	47.79	32.89	296.05

Proposed Nokia Development		Storage Calculations Using Average		
Novatech Project No. 123043		Release Rate Equal to 50% of the Qpeak		
REQUIRED STORAGE - 1:100 YEAR EVENT				
AREA B-3 Controlled Site Flows (Parking Structure)				
OTTAWA IDF CURVE		Qpeak =	46.0	L/s
Area =	1.187 ha	Qavg =	23.0	L/s
C =	0.98	Vol(max) =	603.6	m3
(Vol calculated for Qallow-avg)				
Time (min)	Intensity (mm/hr)	Q (L/s)	Qnet (L/s)	Vol (m3)
5	242.70	788.18	765.18	229.56
10	178.56	579.87	556.87	334.12
15	142.89	464.05	441.05	396.95
20	119.95	389.54	366.54	439.85
25	103.85	337.24	314.24	471.37
30	91.87	298.34	275.34	495.62
35	82.58	268.17	245.17	514.87
40	75.15	244.04	221.04	530.48
45	69.05	224.24	201.24	543.35
50	63.95	207.69	184.69	554.08
55	59.62	193.63	170.63	563.08
60	55.89	181.52	158.52	570.67
65	52.65	170.97	147.97	577.08
70	49.79	161.69	138.69	582.51
75	47.26	153.46	130.46	587.08
90	41.11	133.51	110.51	596.74
105	36.50	118.53	95.53	601.81
120	32.89	106.83	83.83	603.55
135	30.00	97.42	74.42	602.76
150	27.61	89.67	66.67	599.99
165	25.61	83.16	60.16	595.63

Proposed Nokia Development		Storage Calculations Using Average		
Novatech Project No. 123043		Release Rate Equal to 50% of the Qpeak		
REQUIRED STORAGE - 1:100 YR + 20% IDF Increase				
AREA B-3 Controlled Site Flows (Parking Structure)				
OTTAWA IDF CURVE		Qpeak =	46.0	L/s
Area =	1.187 ha	Qavg =	23.0	L/s
C =	0.98	Vol(max) =	761.4	m3
(Vol calculated for Qallow-avg)				
Time (min)	Intensity (mm/hr)	Q (L/s)	Qnet (L/s)	Vol (m3)
5	291.24	945.82	922.82	276.85
10	214.27	695.85	672.85	403.71
15	171.47	556.86	533.86	480.47
20	143.94	467.45	444.45	533.34
25	124.62	404.69	381.69	572.54
30	110.24	358.01	335.01	603.02
35	99.09	321.81	298.81	627.50
40	90.17	292.84	269.84	647.62
45	82.86	269.09	246.09	664.44
50	76.74	249.23	226.23	678.69
55	71.55	232.35	209.35	690.87
60	67.07	217.82	194.82	701.36
65	63.18	205.16	182.16	710.44
70	59.75	194.03	171.03	718.33
75	56.71	184.16	161.16	725.20
90	49.33	160.21	137.21	740.93
105	43.80	142.23	119.23	751.15
120	39.47	128.19	105.19	757.38
135	36.00	116.90	93.90	760.58
150	33.13	107.60	84.60	761.39

Structures	Size (mm)	Area (m ²)	T/G	Inv IN	Inv OUT
UG STORAGE	1144	526.11	80.37		78.22
CB 209-210	1200	2.26	80.10		78.33
STMMH 110	1200	1.13	80.22	78.21	78.19

PI = 3.141592654
 PIPE I.D.= 381 PVC
U/G Storage Pipe Volume
 End Area 0.114 (m²)
 Total Length 18.8 (m)
 Pipe Volume 2.1 (m³)

Area B-3: Storage Table					Underground Storage	Surface Storage						Total Storage		
Elevation (m)	System Depth (m)	UG STORAGE Volume (m ³)	CB 209-210 Volume (m ³)	STMMH 110 Volume (m ³)	Combined Volume (m ³)	UG STORAGE		CB 209-210		STMMH 110		Ponding Volume (m ³)	Total Volume (m ³)	Design Head
						Area (m ²)	Volume (m ³)	Area (m ²)	Volume (m ³)	Area (m ²)	Volume (m ³)			
78.19	0.00	0.00	0.00	0.00	2.14	-	-	-	-	-	-	-	0	-
78.64	0.42	220.97	0.70	0.51	224.32	-	-	-	-	-	-	-	224.3	0.12
78.79	0.57	299.88	1.04	0.68	303.75	-	-	-	-	-	-	-	303.7	0.27
79.36	1.14	599.77	2.33	1.32	605.56	-	-	-	-	-	-	-	605.6	0.84
79.73	1.51	599.77	3.17	1.74	606.82	-	-	-	-	-	-	-	606.8	1.21
80.10	1.88	599.77	4.00	2.16	608.07	0.0	0.00	0.00	0.00	0.00	0.00	0.0	608.1	1.58
80.15						0.00	0.00	0.00	0.00	0.00	0.00	0.0	608.1	1.63
80.20						0.00	0.00	0.00	0.00	0.00	0.00	0.0	608.1	1.68
80.25						0.00	0.00	0.00	0.00	0.00	0.00	0.0	608.1	1.73

Tempest HF Type C ICD	
1:100 Yr	
Flow (L/s) = 46.0	Head (m) = 0.98
Elevation (m) = 79.36	Outlet Pipe Dia.(mm) = 381
Volume (m3) = 603.6	
1:5 Yr	
Flow (L/s) = 29.8	Head (m) = 0.41
Elevation (m) = 78.79	Outlet Pipe Dia.(mm) = 381
Volume (m3) = 303.3	
1:2 Yr	
Flow (L/s) = 23.7	Head (m) = 0.26
Elevation (m) = 78.64	Outlet Pipe Dia.(mm) = 381
Volume (m3) = 222.2	

Orifice Size - 1:100 yr Flow Check		
Q=0.62xAx(2gh) ^{0.5}		
	1:100 yr	Flow Check
Q (m ³ /s) =	0.0460	0.0461
g (m/s ²) =	9.81	9.81
h (m) =	0.98	0.98
A (m ²) =	0.016924444	0.01697
D (m) =	0.14679534	0.14700
D (mm) =	147	147.0

1:5 yr Flow Check	
	1:5 yr
Q (m ³ /s) =	0.0298
g (m/s ²) =	9.81
h (m) =	0.41
A (m ²) =	0.01697
D (m) =	0.147
D (mm) =	147

1:2 yr Flow Check	
	1:2 yr
Q (m ³ /s) =	0.0237
g (m/s ²) =	9.81
h (m) =	0.26
A (m ²) =	0.01697
D (m) =	0.147
D (mm) =	147

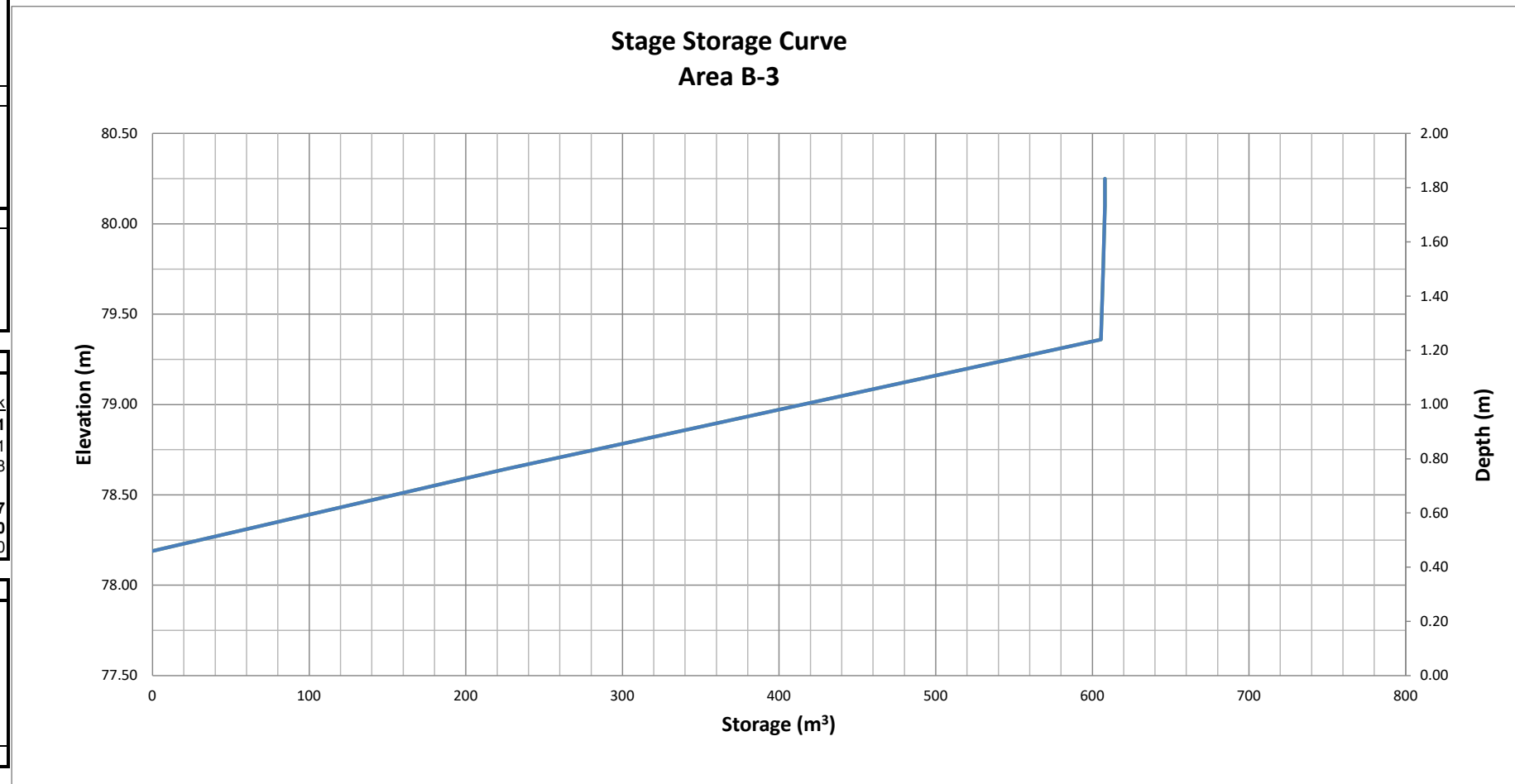

Proposed Nokia Development Storage Calculations Using Average
Novatech Project No. 123043 Release Rate Equal to 50% of the Qpeak
REQUIRED STORAGE - 1:2 YEAR EVENT

AREA B-4 Controlled Site Flows (Access Route)

OTTAWA IDF CURVE Qpeak = 23.9 L/s
 Area = 0.752 ha Qavg = 12.0 L/s
 C = 0.88 Vol(max) = 118.9 m3
 (Vol calculated for Qallow-avg)

Time (min)	Tributary Ar (mm/hr)	Q (L/s)	Qnet (L/s)	Vol (m3)
5	103.57	189.66	177.71	53.31
10	76.81	140.64	128.69	77.22
15	61.77	113.11	101.16	91.04
20	52.03	95.28	83.33	100.00
25	45.17	82.71	70.76	106.14
30	40.04	73.33	61.38	110.48
35	36.06	66.03	54.08	113.57
40	32.86	60.18	48.23	115.75
45	30.24	55.37	43.42	117.25
50	28.04	51.35	39.40	118.20
55	26.17	47.92	35.97	118.71
60	24.56	44.97	33.02	118.87
65	23.15	42.39	30.44	118.73
70	21.91	40.13	28.18	118.34
75	20.81	38.11	26.16	117.73
90	18.14	33.22	21.27	114.87
105	16.13	29.54	17.59	110.84
120	14.56	26.67	14.72	105.95
135	13.30	24.35	12.40	100.42
150	12.25	22.44	10.49	94.37

Proposed Nokia Development Storage Calculations Using Average
Novatech Project No. 123043 Release Rate Equal to 50% of the Qpeak
REQUIRED STORAGE - 1:5 YEAR EVENT

AREA B-4 Controlled Site Flows (Access Route)

OTTAWA IDF CURVE Qpeak = 28.8 L/s
 Area = 0.752 ha Qavg = 14.4 L/s
 C = 0.88 Vol(max) = 165.5 m3
 (Vol calculated for Qallow-avg)

Time (min)	Intensity (mm/hr)	Q (L/s)	Qnet (L/s)	Vol (m3)
5	141.18	258.52	244.12	73.24
10	104.19	190.80	176.40	105.84
15	83.56	153.01	138.61	124.75
20	70.25	128.64	114.24	137.09
25	60.90	111.51	97.11	145.67
30	53.93	98.75	84.35	151.83
35	48.52	88.84	74.44	156.33
40	44.18	80.91	66.51	159.62
45	40.63	74.40	60.00	162.00
50	37.65	68.95	54.55	163.65
55	35.12	64.32	49.92	164.73
60	32.94	60.33	45.93	165.33
65	31.04	56.85	42.45	165.54
70	29.37	53.79	39.39	165.42
75	27.89	51.07	36.67	165.01
90	24.29	44.48	30.08	162.41
105	21.58	39.52	25.12	158.27
120	19.47	35.65	21.25	152.99
135	17.76	32.53	18.13	146.86
150	16.36	29.96	15.56	140.06

Proposed Nokia Development Storage Calculations Using Average
Novatech Project No. 123043 Release Rate Equal to 50% of the Qpeak
REQUIRED STORAGE - 1:100 YEAR EVENT

AREA B-4 Controlled Site Flows (Access Route)

OTTAWA IDF CURVE Qpeak = 43.0 L/s
 Area = 0.752 ha Qavg = 21.5 L/s
 C = 0.97 Vol(max) = 336.3 m3
 (Vol calculated for Qallow-avg)

Time (min)	Intensity (mm/hr)	Q (L/s)	Qnet (L/s)	Vol (m3)
5	242.70	494.30	472.80	141.84
10	178.56	363.66	342.16	205.29
15	142.89	291.02	269.52	242.57
20	119.95	244.29	222.79	267.35
25	103.85	211.50	190.00	285.00
30	91.87	187.10	165.60	298.08
35	82.58	168.18	146.68	308.03
40	75.15	153.04	131.54	315.70
45	69.05	140.63	119.13	321.65
50	63.95	130.25	108.75	326.25
55	59.62	121.43	99.93	329.77
60	55.89	113.84	92.34	332.41
65	52.65	107.22	85.72	334.31
70	49.79	101.40	79.90	335.59
75	47.26	96.24	74.74	336.34
90	41.11	83.73	62.23	336.03
105	36.50	74.33	52.83	332.84
120	32.89	66.99	45.49	327.56
135	30.00	61.09	39.59	320.70
150	27.61	56.23	34.73	312.59

Proposed Nokia Development Storage Calculations Using Average
Novatech Project No. 123043 Release Rate Equal to 50% of the Qpeak
REQUIRED STORAGE - 1:100 YR + 20% IDF Increase

AREA B-4 Controlled Site Flows (Access Route)

OTTAWA IDF CURVE Qpeak = 43.0 L/s
 Area = 0.752 ha Qavg = 21.5 L/s
 C = 0.97 Vol(max) = 426.5 m3
 (Vol calculated for Qallow-avg)

Time (min)	Intensity (mm/hr)	Q (L/s)	Qnet (L/s)	Vol (m3)
5	291.24	593.16	571.66	171.50
10	214.27	436.39	414.89	248.93
15	171.47	349.23	327.73	294.95
20	143.94	293.15	271.65	325.98
25	124.62	253.80	232.30	348.45
30	110.24	224.52	203.02	365.44
35	99.09	201.82	180.32	378.67
40	90.17	183.65	162.15	389.16
45	82.86	168.76	147.26	397.59
50	76.74	156.30	134.80	404.40
55	71.55	145.72	124.22	409.92
60	67.07	136.60	115.10	414.37
65	63.18	128.67	107.17	417.95
70	59.75	121.68	100.18	420.77
75	56.71	115.49	93.99	422.96
90	49.33	100.47	78.97	426.45
105	43.80	89.20	67.70	426.50
120	39.47	80.39	58.89	424.03
135	36.00	73.31	51.81	419.67
150	33.13	67.48	45.98	413.81

Structures	Size (mm)	Area (m ²)	T/G	Inv IN	Inv OUT
UG STORAGE	1144	295.73	80.07		77.71
STMMH 115	1200	1.13	79.95	77.70	77.67
STMMH 116	1200	1.13	79.89	77.64	77.59

PI = 3.141592654
 PIPE I.D. = 381 Concrete Pipe)
U/G Storage Pipe Volume
 End Area 0.114 (m²)
 Total Length 37.6 (m)
 Pipe Volume 4.3 (m³)

Area B-4: Storage Table					Underground Storage	Surface Storage						Total Storage		
Elevation (m)	System Depth (m)	UG STORAGE Volume (m ³)	STMMH 115 Volume (m ³)	STMMH 116 Volume (m ³)	Combined Volume (m ³)	UG STORAGE		STMMH 115		STMMH 116		Ponding Volume (m ³)	Total Volume (m ³)	Design Head
						Area (m ²)	Volume (m ³)	Area (m ²)	Volume (m ³)	Area (m ²)	Volume (m ³)			
77.59	0.00	0.00	0.00	0.00	4.29	-	-	-	-	-	-	-	0	-
78.11	0.40	118.29	0.50	0.59	123.66	-	-	-	-	-	-	-	123.7	0.33
78.26	0.55	162.65	0.67	0.76	168.36	-	-	-	-	-	-	-	168.4	0.48
78.84	1.13	334.17	1.32	1.41	341.20	-	-	-	-	-	-	-	341.2	1.06
78.85	1.14	334.17	1.33	1.43	341.22	-	-	-	-	-	-	-	341.2	1.07
79.10	1.39	334.17	1.62	1.71	341.78	0.0	0.00	0.00	0.00	0.00	0.00	0.0	341.8	1.32
79.15						0.00	0.00	0.00	0.00	0.00	0.00	0.0	341.8	1.37
79.20						0.00	0.00	0.00	0.00	0.00	0.00	0.0	341.8	1.42
79.25						0.00	0.00	0.00	0.00	0.00	0.00	0.0	341.8	1.47

Tempest HF Type C ICD	
1:100 Yr	
Flow (L/s) = 43.0	Head (m) = 1.06
Elevation (m) = 78.84	Outlet Pipe Dia.(mm) = 382
Volume (m3) = 336.3	
1:5 Yr	
Flow (L/s) = 28.8	Head (m) = 0.48
Elevation (m) = 78.26	Outlet Pipe Dia.(mm) = 382
Volume (m3) = 165.5	
1:2 Yr	
Flow (L/s) = 23.9	Head (m) = 0.33
Elevation (m) = 78.11	Outlet Pipe Dia.(mm) = 382
Volume (m3) = 118.9	

Orifice Size - 1:100 yr Flow Check		
Q=0.62xAx(2gh) ^{0.5}		
	1:100 yr	Flow Check
Q (m ³ /s) =	0.0430	0.0429
g (m/s ²) =	9.81	9.81
h (m) =	1.06	1.06
A (m ²) =	0.015215257	0.01517
D (m) =	0.139185727	0.13900
D (mm) =	139	139.0

1:5 yr Flow Check	
	1:5 yr
Q (m ³ /s) =	0.0288
g (m/s ²) =	9.81
h (m) =	0.48
A (m ²) =	0.01517
D (m) =	0.139
D (mm) =	139

1:2 yr Flow Check	
	1:2 yr
Q (m ³ /s) =	0.0239
g (m/s ²) =	9.81
h (m) =	0.33
A (m ²) =	0.01517
D (m) =	0.139
D (mm) =	139

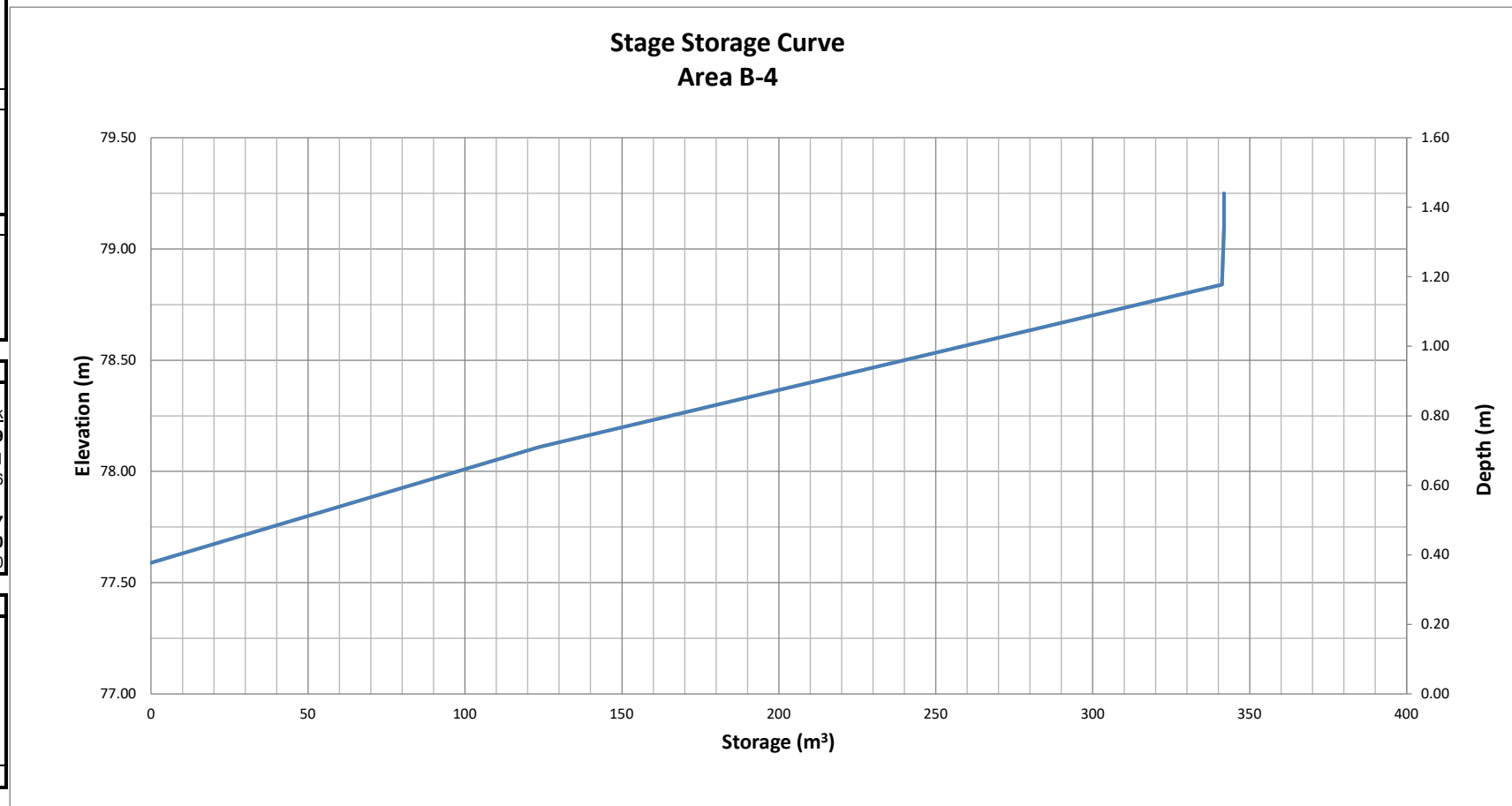

Proposed Nokia Ottawa Innovation Campus					
Novatech Project No. 123043					
Uncontrolled Runoff - 1:2 YEAR EVENT					
AREA C-0 Un-Controlled Runoff - Retained Lands					
OTTAWA IDF CURVE					
Area =		0.064	ha	Qallow =	2.7 L/s
C =		0.20		Vol(max) =	0.0 m3
Time (min)	Intensity (mm/hr)	Q (L/s)	Qnet (L/s)	Vol (m3)	
5	103.57	3.68	0.95	0.28	
10	76.81	2.73	0.00	0.00	
15	61.77	2.19	-0.53	-0.48	
20	52.03	1.85	-0.88	-1.06	
25	45.17	1.60	-1.12	-1.68	
30	40.04	1.42	-1.30	-2.35	
35	36.06	1.28	-1.45	-3.04	
40	32.86	1.17	-1.56	-3.74	
45	30.24	1.07	-1.65	-4.46	
50	28.04	1.00	-1.73	-5.19	
55	26.17	0.93	-1.80	-5.93	
60	24.56	0.87	-1.85	-6.68	
65	23.15	0.82	-1.90	-7.43	
70	21.91	0.78	-1.95	-8.18	
75	20.81	0.74	-1.99	-8.94	
90	18.14	0.64	-2.08	-11.24	
105	16.13	0.57	-2.15	-13.57	
120	14.56	0.52	-2.21	-15.91	
135	13.30	0.47	-2.25	-18.26	
150	12.25	0.43	-2.29	-20.62	

Proposed Nokia Ottawa Innovation Campus					
Novatech Project No. 123043					
Uncontrolled Runoff - 1:5 YEAR EVENT					
AREA C-0 Un-Controlled Runoff - Retained Lands					
OTTAWA IDF CURVE					
Area =		0.064	ha	Qallow =	3.7 L/s
C =		0.20		Vol(max) =	0.0 m3
Time (min)	Intensity (mm/hr)	Q (L/s)	Qnet (L/s)	Vol (m3)	
5	141.18	5.01	1.31	0.39	
10	104.19	3.70	0.00	0.00	
15	83.56	2.97	-0.73	-0.66	
20	70.25	2.49	-1.20	-1.45	
25	60.90	2.16	-1.54	-2.30	
30	53.93	1.91	-1.78	-3.21	
35	48.52	1.72	-1.98	-4.15	
40	44.18	1.57	-2.13	-5.11	
45	40.63	1.44	-2.26	-6.09	
50	37.65	1.34	-2.36	-7.08	
55	35.12	1.25	-2.45	-8.09	
60	32.94	1.17	-2.53	-9.10	
65	31.04	1.10	-2.60	-10.12	
70	29.37	1.04	-2.66	-11.15	
75	27.89	0.99	-2.71	-12.19	
90	24.29	0.86	-2.84	-15.31	
105	21.58	0.77	-2.93	-18.47	
120	19.47	0.69	-3.01	-21.65	
135	17.76	0.63	-3.07	-24.85	
150	16.36	0.58	-3.12	-28.05	

Proposed Nokia Ottawa Innovation Campus					
Novatech Project No. 123043					
Uncontrolled Runoff - 1:100 YEAR EVENT					
AREA C-0 Un-Controlled Runoff - Retained Lands					
OTTAWA IDF CURVE					
Area =		0.064	ha	Qallow =	9.5 L/s
C =		0.30		Vol(max) =	0.0 m3
Time (min)	Intensity (mm/hr)	Q (L/s)	Qnet (L/s)	Vol (m3)	
5	242.70	12.89	3.41	1.02	
10	178.56	9.49	0.00	0.00	
15	142.89	7.59	-1.89	-1.71	
20	119.95	6.37	-3.11	-3.74	
25	103.85	5.52	-3.97	-5.95	
30	91.87	4.88	-4.61	-8.29	
35	82.58	4.39	-5.10	-10.71	
40	75.15	3.99	-5.49	-13.18	
45	69.05	3.67	-5.82	-15.71	
50	63.95	3.40	-6.09	-18.26	
55	59.62	3.17	-6.32	-20.85	
60	55.89	2.97	-6.52	-23.46	
65	52.65	2.80	-6.69	-26.09	
70	49.79	2.65	-6.84	-28.73	
75	47.26	2.51	-6.98	-31.39	
90	41.11	2.18	-7.30	-39.43	
105	36.50	1.94	-7.55	-47.55	
120	32.89	1.75	-7.74	-55.72	
135	30.00	1.59	-7.89	-63.93	
150	27.61	1.47	-8.02	-72.17	

Proposed Nokia Ottawa Innovation Campus					
Novatech Project No. 123043					
Uncontrolled Runoff - 1:100 YR + 20% IDF Increase					
AREA C-0 Un-Controlled Runoff - Retained Lands					
OTTAWA IDF CURVE					
Area =		0.064	ha	Qallow =	11.4 L/s
C =		0.30		Vol(max) =	0.0 m3
Time (min)	Intensity (mm/hr)	Q (L/s)	Qnet (L/s)	Vol (m3)	
5	291.24	15.47	4.09	1.23	
10	214.27	11.38	0.00	0.00	
15	171.47	9.11	-2.27	-2.05	
20	143.94	7.65	-3.74	-4.48	
25	124.62	6.62	-4.76	-7.14	
30	110.24	5.86	-5.53	-9.95	
35	99.09	5.26	-6.12	-12.85	
40	90.17	4.79	-6.59	-15.82	
45	82.86	4.40	-6.98	-18.85	
50	76.74	4.08	-7.31	-21.92	
55	71.55	3.80	-7.58	-25.02	
60	67.07	3.56	-7.82	-28.15	
65	63.18	3.36	-8.03	-31.30	
70	59.75	3.17	-8.21	-34.48	
75	56.71	3.01	-8.37	-37.67	
90	49.33	2.62	-8.76	-47.32	
105	43.80	2.33	-9.06	-57.05	
120	39.47	2.10	-9.29	-66.86	
135	36.00	1.91	-9.47	-76.71	
150	33.13	1.76	-9.62	-86.60	

Proposed Nokia Development Storage Calculations Using Average
Novatech Project No. 123043 Release Rate Equal to 50% of the Qpeak
REQUIRED STORAGE - 1:2 YEAR EVENT

AREA C-1 Controlled Site Flows (Retained Lands)

OTTAWA IDF CURVE Qpeak = 26.1 L/s
 Area = 0.642 ha Qavg = 13.1 L/s
 C = 0.20 Vol(max) = 8.6 m3
 (Vol calculated for Qallow-avg)

Time (min)	Tributary Ar (mm/hr)	Q (L/s)	Qnet (L/s)	Vol (m3)
5	103.57	37.03	23.98	7.19
10	76.81	27.46	14.41	8.65
15	61.77	22.08	9.03	8.13
20	52.03	18.60	5.55	6.66
25	45.17	16.15	3.10	4.65
30	40.04	14.32	1.27	2.28
35	36.06	12.89	-0.16	-0.33
40	32.86	11.75	-1.30	-3.12
45	30.24	10.81	-2.24	-6.05
50	28.04	10.03	-3.02	-9.07
55	26.17	9.36	-3.69	-12.19
60	24.56	8.78	-4.27	-15.37
65	23.15	8.28	-4.77	-18.62
70	21.91	7.83	-5.22	-21.91
75	20.81	7.44	-5.61	-25.24
90	18.14	6.49	-6.56	-35.44
105	16.13	5.77	-7.28	-45.88
120	14.56	5.21	-7.84	-56.48
135	13.30	4.75	-8.30	-67.20
150	12.25	4.38	-8.67	-78.03

Proposed Nokia Development Storage Calculations Using Average
Novatech Project No. 123043 Release Rate Equal to 50% of the Qpeak
REQUIRED STORAGE - 1:5 YEAR EVENT

AREA C-1 Controlled Site Flows (Retained Lands)

OTTAWA IDF CURVE Qpeak = 26.5 L/s
 Area = 0.642 ha Qavg = 13.3 L/s
 C = 0.20 Vol(max) = 15.0 m3
 (Vol calculated for Qallow-avg)

Time (min)	Intensity (mm/hr)	Q (L/s)	Qnet (L/s)	Vol (m3)
5	141.18	50.47	37.22	11.17
10	104.19	37.25	24.00	14.40
15	83.56	29.87	16.62	14.96
20	70.25	25.12	11.87	14.24
25	60.90	21.77	8.52	12.78
30	53.93	19.28	6.03	10.85
35	48.52	17.35	4.10	8.60
40	44.18	15.80	2.55	6.11
45	40.63	14.53	1.28	3.44
50	37.65	13.46	0.21	0.63
55	35.12	12.56	-0.69	-2.29
60	32.94	11.78	-1.47	-5.30
65	31.04	11.10	-2.15	-8.39
70	29.37	10.50	-2.75	-11.55
75	27.89	9.97	-3.28	-14.76
90	24.29	8.68	-4.57	-24.66
105	21.58	7.72	-5.53	-34.86
120	19.47	6.96	-6.29	-45.29
135	17.76	6.35	-6.90	-55.88
150	16.36	5.85	-7.40	-66.60

Proposed Nokia Development Storage Calculations Using Average
Novatech Project No. 123043 Release Rate Equal to 50% of the Qpeak
REQUIRED STORAGE - 1:100 YEAR EVENT

AREA C-1 Controlled Site Flows (Retained Lands)

OTTAWA IDF CURVE Qpeak = 27.0 L/s
 Area = 0.642 ha Qavg = 13.5 L/s
 C = 0.25 Vol(max) = 49.6 m3
 (Vol calculated for Qallow-avg)

Time (min)	Intensity (mm/hr)	Q (L/s)	Qnet (L/s)	Vol (m3)
5	242.70	108.44	94.94	28.48
10	178.56	79.78	66.28	39.77
15	142.89	63.85	50.35	45.31
20	119.95	53.60	40.10	48.11
25	103.85	46.40	32.90	49.35
30	91.87	41.05	27.55	49.59
35	82.58	36.90	23.40	49.13
40	75.15	33.58	20.08	48.18
45	69.05	30.85	17.35	46.85
50	63.95	28.58	15.08	45.23
55	59.62	26.64	13.14	43.36
60	55.89	24.97	11.47	41.31
65	52.65	23.52	10.02	39.09
70	49.79	22.25	8.75	36.74
75	47.26	21.11	7.61	34.27
90	41.11	18.37	4.87	26.29
105	36.50	16.31	2.81	17.69
120	32.89	14.70	1.20	8.63
135	30.00	13.40	-0.10	-0.79
150	27.61	12.34	-1.16	-10.47

Proposed Nokia Development Storage Calculations Using Average
Novatech Project No. 123043 Release Rate Equal to 50% of the Qpeak
REQUIRED STORAGE - 1:100 YR + 20% IDF Increase

AREA C-1 Controlled Site Flows (Retained Lands)

OTTAWA IDF CURVE Qpeak = 27.0 L/s
 Area = 0.642 ha Qavg = 13.5 L/s
 C = 0.25 Vol(max) = 64.6 m3
 (Vol calculated for Qallow-avg)

Time (min)	Intensity (mm/hr)	Q (L/s)	Qnet (L/s)	Vol (m3)
5	291.24	130.13	116.63	34.99
10	214.27	95.74	82.24	49.34
15	171.47	76.62	63.12	56.81
20	143.94	64.31	50.81	60.98
25	124.62	55.68	42.18	63.27
30	110.24	49.26	35.76	64.36
35	99.09	44.28	30.78	64.63
40	90.17	40.29	26.79	64.30
45	82.86	37.02	23.52	63.51
50	76.74	34.29	20.79	62.37
55	71.55	31.97	18.47	60.95
60	67.07	29.97	16.47	59.29
65	63.18	28.23	14.73	57.44
70	59.75	26.70	13.20	55.42
75	56.71	25.34	11.84	53.27
90	49.33	22.04	8.54	46.13
105	43.80	19.57	6.07	38.24
120	39.47	17.64	4.14	29.79
135	36.00	16.08	2.58	20.93
150	33.13	14.80	1.30	11.74

Structures	Size (mm)	Area (m ²)	T/G	Inv IN	Inv OUT
CB 208	1200	1.13	80.00	-	78.37
-	-	-	-	-	-
-	-	-	-	-	-

PI = 3.141592654
 PIPE I.D.= 301 PVC
 U/G Storage Pipe Volume
 End Area 0.071 (m²)
 Total Length 0.0 (m)
 Pipe Volume 0.0 (m³)

Area C-1: Storage Table					Underground Storage	Surface Storage						Total Storage		
Elevation (m)	System Depth (m)	CB 208 Volume (m ³)	Volume (m ³)	Volume (m ³)	Combined Volume (m ³)	CB 208						Ponding Volume (m ³)	Total Volume (m ³)	Design Head
						Area (m ²)	Volume (m ³)	Area (m ²)	Volume (m ³)	Area (m ²)	Volume (m ³)			
78.37	0.00	0.00	-	-	0.00	-	-	-	-	-	-	-	0	-
78.67	0.30	0.34	-	-	0.34	-	-	-	-	-	-	-	0.3	0.15
78.97	0.60	0.68	-	-	0.68	-	-	-	-	-	-	-	0.7	0.45
79.27	0.90	1.02	-	-	1.02	-	-	-	-	-	-	-	1.0	0.75
79.57	1.20	1.36	-	-	1.36	-	-	-	-	-	-	-	1.4	1.05
80.00	1.63	1.84	-	-	1.84	0.0	0.00	-	-	-	-	0.0	1.8	1.48
80.17						103.80	8.82	-	-	-	-	8.8	10.7	1.65
80.22						198.60	16.38	-	-	-	-	16.4	18.2	1.70
80.30						640.32	49.94	-	-	-	-	49.9	51.8	1.78
80.32						731.67	63.66	-	-	-	-	63.7	65.5	1.80

Tempest HF Type B ICD

1:100 Yr
 Flow (L/s) = 27.0
 Head (m) = 1.78
 Elevation (m) = **80.30**
 Outlet Pipe Dia.(mm) = 301
 Volume (m3) = 49.6

1:5 Yr
 Flow (L/s) = 26.5
 Head (m) = 1.70
 Elevation (m) = **80.22**
 Outlet Pipe Dia.(mm) = 301
 Volume (m3) = 15.0

1:2 Yr
 Flow (L/s) = 26.1
 Head (m) = 1.65
 Elevation (m) = **80.17**
 Outlet Pipe Dia.(mm) = 301
 Volume (m3) = 8.6

Orifice Size - 1:100 yr Flow Check
 $Q=0.62xAx(2gh)^{0.5}$

	1:100 yr	Flow Check
Q (m ³ /s) =	0.0270	0.0271
g (m/s ²) =	9.81	9.81
h (m) =	1.78	1.78
A (m ²) =	0.007370103	0.00739
D (m) =	0.096870568	0.09700
D (mm) =	97	97.0

1:5 yr Flow Check

	1:5 yr
Q (m ³ /s) =	0.0265
g (m/s ²) =	9.81
h (m) =	1.70
A (m ²) =	0.00739
D (m) =	0.097
D (mm) =	97

1:2 yr Flow Check

	1:2 yr
Q (m ³ /s) =	0.0261
g (m/s ²) =	9.81
h (m) =	1.65
A (m ²) =	0.00739
D (m) =	0.097
D (mm) =	97

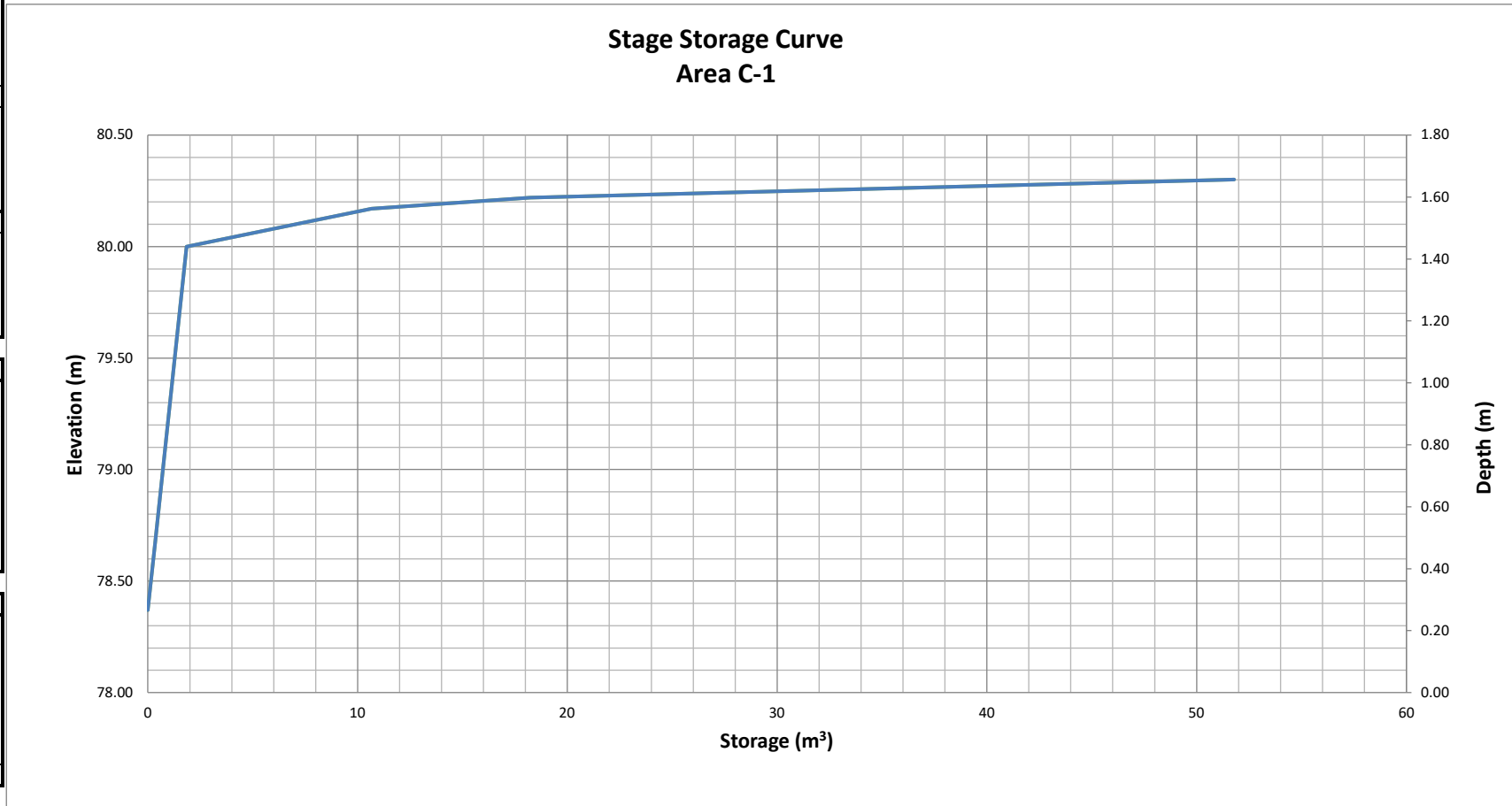

Proposed Nokia Development Storage Calculations Using Average
Novatech Project No. 123043 Release Rate Equal to 50% of the Qpeak
REQUIRED STORAGE - 1:2 YEAR EVENT

AREA C-2 Controlled Site Flows (Retained Lands - ROW)

OTTAWA IDF CURVE Qpeak = 1.6 L/s
 Area = 0.075 ha Qavg = 0.8 L/s
 C = 0.90 Vol(max) = 14.0 m3
 (Vol calculated for Qallow-avg)

Time (min)	Tributary Ar (mm/hr)	Q (L/s)	Qnet (L/s)	Vol (m3)
5	103.57	19.35	18.55	5.57
10	76.81	14.35	13.55	8.13
15	61.77	11.54	10.74	9.67
20	52.03	9.72	8.92	10.71
25	45.17	8.44	7.64	11.46
30	40.04	7.48	6.68	12.03
35	36.06	6.74	5.94	12.47
40	32.86	6.14	5.34	12.82
45	30.24	5.65	4.85	13.10
50	28.04	5.24	4.44	13.32
55	26.17	4.89	4.09	13.50
60	24.56	4.59	3.79	13.64
65	23.15	4.33	3.53	13.75
70	21.91	4.09	3.29	13.84
75	20.81	3.89	3.09	13.90
90	18.14	3.39	2.59	13.99
105	16.13	3.01	2.21	13.95
120	14.56	2.72	1.92	13.83
135	13.30	2.48	1.68	13.64
150	12.25	2.29	1.49	13.41

Proposed Nokia Development Storage Calculations Using Average
Novatech Project No. 123043 Release Rate Equal to 50% of the Qpeak
REQUIRED STORAGE - 1:5 YEAR EVENT

AREA C-2 Controlled Site Flows (Retained Lands - ROW)

OTTAWA IDF CURVE Qpeak = 2.0 L/s
 Area = 0.075 ha Qavg = 1.0 L/s
 C = 0.90 Vol(max) = 19.1 m3
 (Vol calculated for Qallow-avg)

Time (min)	Intensity (mm/hr)	Q (L/s)	Qnet (L/s)	Vol (m3)
5	141.18	26.38	25.38	7.61
10	104.19	19.47	18.47	11.08
15	83.56	15.61	14.61	13.15
20	70.25	13.13	12.13	14.55
25	60.90	11.38	10.38	15.57
30	53.93	10.08	9.08	16.34
35	48.52	9.07	8.07	16.94
40	44.18	8.26	7.26	17.42
45	40.63	7.59	6.59	17.80
50	37.65	7.04	6.04	18.11
55	35.12	6.56	5.56	18.36
60	32.94	6.16	5.16	18.56
65	31.04	5.80	4.80	18.72
70	29.37	5.49	4.49	18.85
75	27.89	5.21	4.21	18.95
90	24.29	4.54	3.54	19.11
105	21.58	4.03	3.03	19.11
120	19.47	3.64	2.64	18.99
135	17.76	3.32	2.32	18.79
150	16.36	3.06	2.06	18.52

Proposed Nokia Development Storage Calculations Using Average
Novatech Project No. 123043 Release Rate Equal to 50% of the Qpeak
REQUIRED STORAGE - 1:100 YEAR EVENT

AREA C-2 Controlled Site Flows (Retained Lands - ROW)

OTTAWA IDF CURVE Qpeak = 3.0 L/s
 Area = 0.075 ha Qavg = 1.5 L/s
 C = 1.00 Vol(max) = 38.4 m3
 (Vol calculated for Qallow-avg)

Time (min)	Intensity (mm/hr)	Q (L/s)	Qnet (L/s)	Vol (m3)
5	242.70	50.39	48.89	14.67
10	178.56	37.07	35.57	21.34
15	142.89	29.67	28.17	25.35
20	119.95	24.91	23.41	28.09
25	103.85	21.56	20.06	30.09
30	91.87	19.07	17.57	31.63
35	82.58	17.15	15.65	32.86
40	75.15	15.60	14.10	33.85
45	69.05	14.34	12.84	34.66
50	63.95	13.28	11.78	35.34
55	59.62	12.38	10.88	35.90
60	55.89	11.61	10.11	36.38
65	52.65	10.93	9.43	36.78
70	49.79	10.34	8.84	37.12
75	47.26	9.81	8.31	37.40
90	41.11	8.54	7.04	37.99
105	36.50	7.58	6.08	38.29
120	32.89	6.83	5.33	38.38
135	30.00	6.23	4.73	38.30
150	27.61	5.73	4.23	38.10

Proposed Nokia Development Storage Calculations Using Average
Novatech Project No. 123043 Release Rate Equal to 50% of the Qpeak
REQUIRED STORAGE - 1:100 YR + 20% IDF Increase

AREA C-2 Controlled Site Flows (Retained Lands - ROW)

OTTAWA IDF CURVE Qpeak = 3.0 L/s
 Area = 0.075 ha Qavg = 1.5 L/s
 C = 1.00 Vol(max) = 48.4 m3
 (Vol calculated for Qallow-avg)

Time (min)	Intensity (mm/hr)	Q (L/s)	Qnet (L/s)	Vol (m3)
5	291.24	60.47	58.97	17.69
10	214.27	44.49	42.99	25.79
15	171.47	35.60	34.10	30.69
20	143.94	29.89	28.39	34.06
25	124.62	25.87	24.37	36.56
30	110.24	22.89	21.39	38.50
35	99.09	20.58	19.08	40.06
40	90.17	18.72	17.22	41.34
45	82.86	17.20	15.70	42.40
50	76.74	15.93	14.43	43.30
55	71.55	14.86	13.36	44.07
60	67.07	13.93	12.43	44.74
65	63.18	13.12	11.62	45.31
70	59.75	12.41	10.91	45.80
75	56.71	11.77	10.27	46.23
90	49.33	10.24	8.74	47.21
105	43.80	9.09	7.59	47.84
120	39.47	8.20	6.70	48.21
135	36.00	7.47	5.97	48.39
150	33.13	6.88	5.38	48.41

Structures	Size (mm)	Area (m ²)	T/G	Inv IN	Inv OUT
UG STORAGE	1144	33.70	80.20		78.24
CBMH 261	1200	1.13	80.10	78.22	78.19
-	-	-	-	-	-

PI = 3.141592654
 PIPE I.D. = 304.8 PVC
U/G Storage Pipe Volume
 End Area 0.073 (m²)
 Total Length 5.0 (m)
 Pipe Volume 0.4 (m³)

Area C-2: Storage Table					Underground Storage	Surface Storage						Total Storage		
Elevation (m)	System Depth (m)	UG STORAGE Volume (m ³)	CBMH 261 Volume (m ³)	- Volume (m ³)	Combined Volume (m ³)	UG STORAGE		CBMH 261		-		Ponding Volume (m ³)	Total Volume (m ³)	Design Head
						Area (m ²)	Volume (m ³)	Area (m ²)	Volume (m ³)	Area (m ²)	Volume (m ³)			
78.19	0.00	0.00	0.00	0.00	0.36	-	-	-	-	-	-	-	0	-
78.62	0.38	12.81	0.49	0.49	14.14	-	-	-	-	-	-	-	14.1	0.28
78.76	0.52	17.53	0.64	0.64	19.18	-	-	-	-	-	-	-	19.2	0.42
79.30	1.06	35.72	1.26	1.26	38.60	-	-	-	-	-	-	-	38.6	0.96
79.38	1.14	35.72	1.35	1.35	38.78	-	-	-	-	-	-	-	38.8	1.04
80.10	1.86	35.72	2.16	2.16	40.41	0.0	0.00	0.00	0.00	-	-	0.0	40.4	1.76
80.15						0.00	0.00	3.61	0.09	-	-	0.1	40.5	1.81
80.20						0.00	0.00	10.31	0.44	-	-	0.4	40.8	1.86
80.25						0.00	0.00	19.55	1.18	-	-	1.2	41.6	1.91

Tempest Vortex LMF Model 100 ICD	
1:100 Yr	
Flow (L/s) = 3.0	Head (m) = 0.96
Elevation (m) = 79.30	Outlet Pipe Dia.(mm) = 304.8
Volume (m3) = 38.4	
1:5 Yr	
Flow (L/s) = 2.0	Head (m) = 0.42
Elevation (m) = 78.76	Outlet Pipe Dia.(mm) = 304.8
Volume (m3) = 19.1	
1:2 Yr	
Flow (L/s) = 1.6	Head (m) = 0.28
Elevation (m) = 78.62	Outlet Pipe Dia.(mm) = 304.8
Volume (m3) = 14.0	

Orifice Size - 1:100 yr Flow Check		
$Q=0.62 \times A \times (2gh)^{0.5}$		
	1:100 yr	Flow Check
Q (m ³ /s) =	0.0030	0.0030
g (m/s ²) =	9.81	9.81
h (m) =	0.96	0.96
A (m ²) =	0.001116318	0.00113
D (m) =	0.037700669	0.03800
D (mm) =	38	38.0

1:5 yr Flow Check	
	1:5 yr
Q (m ³ /s) =	0.0020
g (m/s ²) =	9.81
h (m) =	0.42
A (m ²) =	0.00113
D (m) =	0.038
D (mm) =	38

1:2 yr Flow Check	
	1:2 yr
Q (m ³ /s) =	0.0016
g (m/s ²) =	9.81
h (m) =	0.28
A (m ²) =	0.00113
D (m) =	0.038
D (mm) =	38

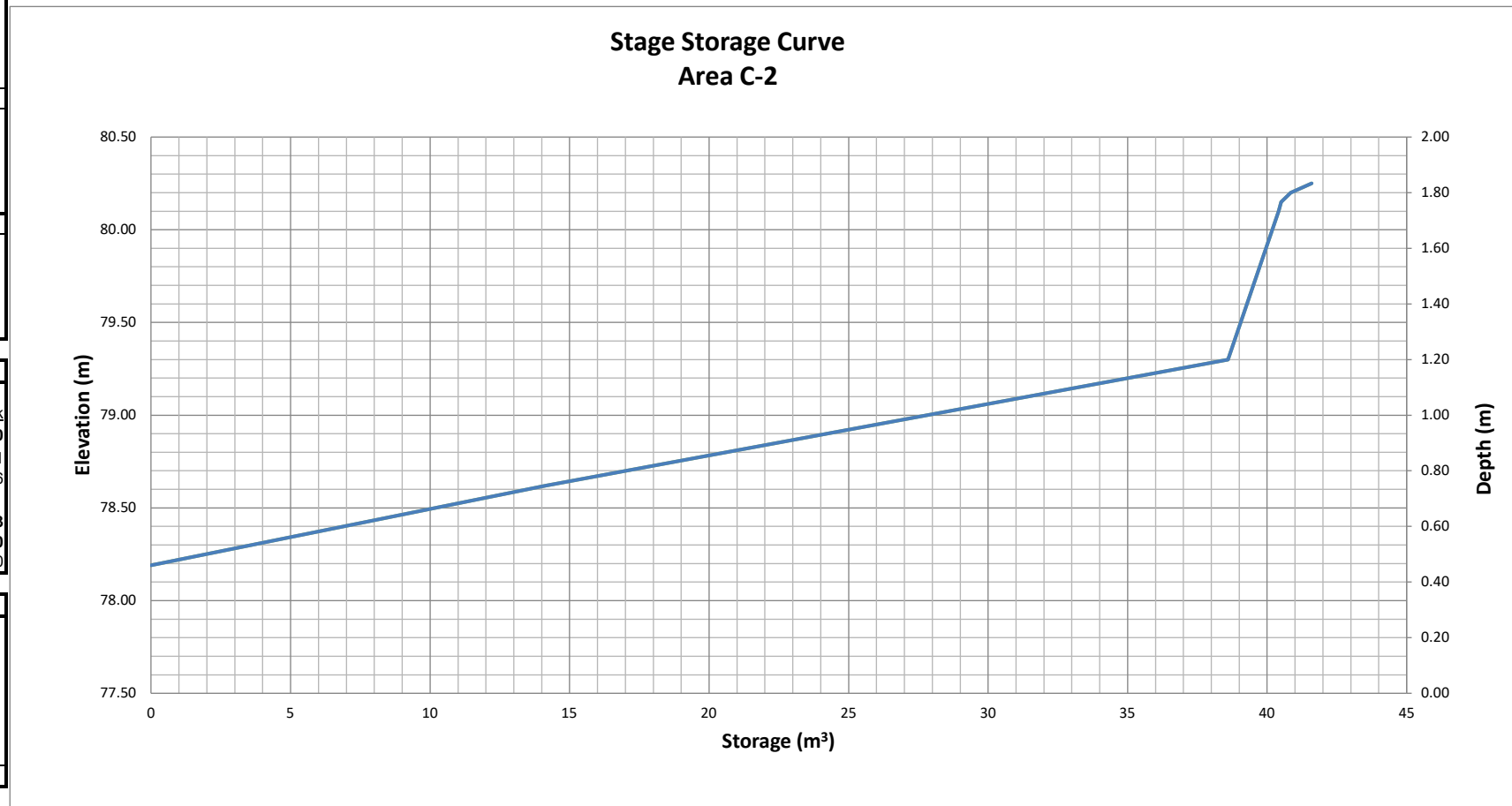

STORM SEWER DESIGN SHEET



Novatech Project #: 123043
 Project Name: Nokia Ottawa Innovation Campus
 Date: 11/14/2024
 Input By: KD
 Reviewed By: FST
 Drawing Reference: C500

520 & 570 March Road - Nokia Ottawa Innovation Campus
Northern Outlet through KRP Lands
1:5 Year Storm Event

Legend: Design Input by User
 As-Built Input by User
 Cumulative Cell
 Calculated Design Cell Output
 Calculated Uncontrolled Peak Flow Cell Output
 Design Input Restricted Peak Flow Cell
 Reference: City of Ottawa - Sewer Design Guidelines (2012 and TBs)
 MOE - Design Guidelines for Sewage Works (2008)

Storm Design Event = 5 Year

Location				Flow								Design Capacity								
Location	Area ID	From MH	To MH	Area A (ha.)	Runoff Coefficient C	Indivi. 2.78 AC	Accum. 2.78 AC	Time of Conc. Tc (min.)	Rain Intensity I (mm/hr)	Total Uncontrolled Peak Flow Q (L/s)	Total Restricted Peak Flow (L/s)	Pipe Length (m)	Pipe Size (mm) and Material	Pipe ID Actual (m)	Roughness n	Design Grade So (%)	Proposed Sewer Pipe Sizing / Design			
																	Capacity Qfull (L/s)	Full Flow Velocity (m/s)	Time of Flow (min.)	Q / Qfull
Lifestyle Street	A-1	STMMH 101	STMMH 102	0.14	0.89	0.35	0.35	10.00	104.19	36.3		58.0	300 PVC	0.3048	0.013	1.00	100.9	1.38	0.70	36.0%
Lifestyle Street	A-1	STMMH 102	STMMH 103	0.00	-	0.00	0.00	10.70	100.64	Flows controlled by ICD	8.5	37.4	300 PVC	0.3048	0.013	2.00	142.7	1.96	0.32	6.0%
570 March Road	A-3, A-5	Retail West/Office	STMMH 103	0.39	0.90	0.97	0.97	10.00	104.19	Controlled by 20 RDs	14.9	25.8	375 PVC	0.381	0.013	2.00	258.7	2.27	0.19	5.8%
Lifestyle Street	A-1, A-3, A-5	STMMH 103	STMMH 104	0.00	-	0.00	0.00	11.02	99.11		23.4	20.0	375 PVC	0.381	0.013	2.00	258.7	2.27	0.15	9.0%
570 March Road	A-4, A-6	Retail East/Link	STMMH 104	0.19	0.90	0.48	0.48	10.00	104.19	Controlled by 10 RDs	8.3	14.3	300 PVC	0.3048	0.013	1.00	100.9	1.38	0.17	8.2%
Lifestyle Street	A-1, A3-A6	STMMH 104	STMMH 105	0.00	-	0.00	0.00	11.16	98.42		31.7	27.3	375 PVC	0.381	0.013	2.00	258.7	2.27	0.20	12.3%
Lifestyle Street	A-2	CBMH 249	CBMH 250	0.05	0.86	0.12	0.12	10.00	104.19		12.1	13.2	300 PVC	0.3048	0.013	0.35	59.7	0.82	0.27	20.3%
Lifestyle Street	A-2	CBMH 250	CBMH 251	0.17	0.86	0.40	0.52	10.27	102.79		53.4	6.3	300 PVC	0.3048	0.013	0.35	59.7	0.82	0.13	89.4%
Lifestyle Street	A-2	CBMH 251	STMMH 105	0.08	0.86	0.18	0.70	10.40	102.14	Flows controlled by ICD	26.0	3.2	300 PVC	0.3048	0.013	2.00	142.7	1.96	0.03	18.2%
Lifestyle Street	A1-A6	STMMH 105	OGS UNIT 1	0.00	-	0.00	0.00	11.37	97.49		57.7	8.1	375 PVC	0.381	0.013	0.35	108.2	0.95	0.14	53.3%
Legget Drive	A1-A6	OGS UNIT 1	EX CBMH "A"	0.00	-	0.00	0.00	11.51	96.85		57.7	70.1	375 PVC	0.381	0.013	0.40	115.7	1.01	1.15	49.9%
555 Legget Drive (KRP)	A1-A6, E-3	EX CBMH "A"	EX CBMH "B"	0.33	0.74	0.68	0.68	12.66	91.97		62.4	46.0	375 PVC	0.381	0.013	1.62	232.8	2.04	0.38	51.6%
555 Legget Drive (KRP)	E-1, E-2	EX CBMH	EX CBMH "B"	0.63	0.85	1.49	1.49	10.00	104.19		155.1	59.7	375 PVC	0.381	0.013	0.60	141.7	1.24	0.80	109.5%
535 Legget Drive (KRP)	A1-A6, E1-E4	EX CBMH "B"	EX CBMH "C"	0.22	0.76	0.46	2.63	13.03	90.50		238.2	34.9	450 PVC	0.4572	0.013	0.67	243.5	1.48	0.39	121.5%
535 Legget Drive (KRP)	E-5	Building	EX CBMH "C"	0.11	0.90	0.28	0.28	10.00	104.19		28.7	28.0	300 PVC	0.3048	0.013	0.50	71.3	0.98	0.48	40.2%
535 Legget Drive (KRP)	A1-A6, E1-E6	EX CBMH "C"	EX STMMH "D"	0.09	0.90	0.23	3.13	13.43	89.01		278.8	37.2	450 PVC	0.4572	0.013	2.40	460.8	2.81	0.22	73.0%
359 Terry Fox Drive (KRP)	E-7, E-8, E-9	EX CBMH	EX STMMH "D"	0.31	0.74	0.64	0.64	10.00	104.19		66.6	52.5	250 PVC	0.254	0.013	0.43	40.7	0.80	1.09	163.6%
535 Legget Drive (KRP)	A1-A6, E1-E9	EX STMMH "D"	EX CBMH "E"	0.35	0.75	0.73	4.50	13.65	88.20		397.0	24.0	450 PVC	0.4572	0.013	2.66	485.1	2.95	0.14	93.7%
525 Legget Drive (KRP)	A1-A6, E1-E11	EX CBMH "E"	EX CBMH "F"	0.19	0.90	0.48	4.98	13.78	87.71		436.5	65.0	900 CONC	0.9144	0.013	0.46	1280.9	1.95	0.56	38.6%
359 Terry Fox Drive (KRP)	E-12, E-13	EX CBMH	EX CBMH "F"	0.27	0.90	0.68	0.68	10.00	104.19		70.4	16.6	250 PVC	0.254	0.013	1.00	62.0	1.22	0.23	113.5%
525 Legget Drive (KRP)	A1-A6, E1-E14	EX CBMH "F"	EX CBMH "G"	0.10	0.90	0.25	5.90	14.34	85.76		506.2	24.4	900 CONC	0.9144	0.013	0.57	1425.9	2.17	0.19	39.5%
525 Legget Drive (KRP)	A1-A6, E1-E15	EX CBMH "G"	FUT STMMH "H"	0.03	0.68	0.06	5.96	14.53	85.12		507.3	7.4	900 CONC	0.9144	0.013	0.36	1133.2	1.73	0.07	49.9%

STORM SEWER DESIGN SHEET



Location				Flow								Design Capacity								
Location	Area ID	From MH	To MH	Area A (ha.)	Runoff Coefficient C	Indivi. 2.78 AC	Accum. 2.78 AC	Time of Conc. Tc (min.)	Rain Intensity I (mm/hr)	Total Uncontrolled Peak Flow Q (L/s)	Total Restricted Peak Flow (L/s)	Pipe Length (m)	Pipe Size (mm) and Material	Pipe ID Actual (m)	Roughness n	Design Grade So (%)	Capacity Qfull (L/s)	Full Flow Velocity (m/s)	Time of Flow (min.)	Q / Qfull
525 Legget Drive (KRP)	E-17	Building	EX CBMH	0.17	0.90	0.43	0.43	10.00	104.19	44.3		3.3	250 PVC	0.254	0.013	1.00	62.0	1.22	0.04	71.4%
525 Legget Drive (KRP)	E-16, E-17	EX CBMH	FUT STMMH 1	0.13	0.90	0.33	0.75	10.04	103.96	78.0		32.7	375 PVC	0.381	0.013	2.23	273.1	2.40	0.23	28.6%
525 Legget Drive (KRP)	E-16, E-17	FUT STMMH 1	FUT CBMH 1	0.00	-	0.00	0.75	10.27	102.78	77.1		7.9	375 PVC	0.381	0.013	0.50	129.3	1.13	0.12	59.6%
525 Legget Drive (KRP)	E-16, E-17, F-4	FUT CBMH 1	FUT STMMH 2	0.02	0.90	0.05	0.80	10.39	102.18	81.8		28.9	375 PVC	0.381	0.013	0.50	129.3	1.13	0.42	63.3%
525 Legget Drive (KRP)	E-16, E-17, F-4	FUT STMMH 2	FUT CBMH 2	0.00	-	0.00	0.80	10.81	100.09	80.1		6.0	375 PVC	0.381	0.013	0.50	129.3	1.13	0.09	62.0%
525 Legget Drive (KRP)	E-16, E-17, F-4, F-5	FUT CBMH 2	FUT STMMH 3	0.02	0.90	0.05	0.85	10.90	99.66	84.8		9.8	450 PVC	0.4572	0.013	0.25	148.7	0.91	0.18	57.0%
525 Legget Drive (KRP)	E-18	Building	FUT STMMH 3	0.54	0.90	1.35	1.35	10.00	104.19	140.8		4.2	300 PVC	0.3048	0.013	0.50	71.3	0.98	0.07	197.3%
525 Legget Drive (KRP)	E-16, E-17, E-18, F-4, F-5	FUT STMMH 3	FUT STMMH 4	0.00	-	0.00	2.20	11.08	98.81	217.6		9.7	525 PVC	0.5334	0.013	0.20	200.6	0.90	0.18	108.4%
525 Legget Drive (KRP)	F-1, F-2, F-3	CAP	FUT STMMH 4	0.16	0.90	0.40	0.40	10.00	104.19	41.7		3.0	450 PVC	0.4572	0.013	1.00	297.4	1.81	0.03	14.0%
525 Legget Drive (KRP)	E-16, E-17, E-18, F1-5	FUT STMMH 4	FUT STMMH "H"	0.00	-	0.00	2.60	11.26	97.97	254.9		46.8	525 PVC	0.5334	0.013	0.20	200.6	0.90	0.87	127.1%
525 Legget Drive (KRP)	A1-A6, E1-E18, F1-F6	FUT STMMH "H"	FUT STMMH "I"	0.02	0.90	0.05	8.61	14.60	84.88	730.9	57.7	35.9	975 CONC	0.9906	0.013	0.24	1145.4	1.49	0.40	68.9%
525 Legget Drive (KRP)	A1-A6, E1-E18, F1-F8	FUT STMMH "I"	FUT STMMH "J"	0.18	0.90	0.45	9.06	15.00	83.56	757.2	57.7	22.1	975 CONC	0.9906	0.013	0.24	1145.4	1.49	0.25	71.1%
525 Legget Drive (KRP)	A1-A6, E1-E18, F1-F8	FUT STMMH "J"	FUT STMMH "K"	0.00	-	0.00	9.06	15.25	82.77	757.2	57.7	24.7	975 CONC	0.9906	0.013	0.24	1145.4	1.49	0.28	71.1%
525 Legget Drive (KRP)	A1-A6, E1-E18, F1-F8	FUT STMMH "K"	SWM POND	0.00	-	0.00	9.06	15.52	81.90	757.2	57.7	7.7	975 CONC	0.9906	0.013	0.24	1145.4	1.49	0.09	71.1%
Totals				4.88								922.1								

Demand Equation / Parameters

1. Q = 2.78 ACI

Definitions

- Q = Peak flow in litres per second (L/s)
- A = Area in hectares (ha)
- C = Weighted runoff coefficient (increased by 25% for 100-year)
- I = Rainfall intensity in millimeters per hour (mm/hr)

Rainfall intensity is based on City of Ottawa IDF data presented in the City of Ottawa - Sewer Design Guidelines

Notes

- 1) Refer to the Novatech Report "Development Servicing Study and Stormwater Management Report - Nokia Ottawa Innovation Campus" (R-2023-082) for on-site storm drainage and stormwater details.
- 2) Refer to the Novatech Report "Sanitary and Storm Trunk Sewer Design Brief - Nokia Ottawa Innovation Campus" (R-2024-130) for off-site storm drainage and stormwater details.
- 3) Refer to Novatech Drawings C100 and C500 for the storm structure designations, storm pipe details and control structure tables.
- 4) Refer to Novatech Drawing C501 and associated storm sewer design sheet for STM drainage areas that contribute to southern STM Sewer on KRP Lands.
- 5) Stormwater flows from drainage areas A-0a and A-0b do not enter the storm sewer in Lifestyle Street, hence are not tributary to the northern STM Sewer on KRP Lands and have therefore been excluded from this design sheet.

Capacity Equation

$$Q_{full} = 1000 \cdot (1/n) \cdot A_p \cdot R^{2/3} \cdot S_o^{0.5}$$

Definitions

- Q full = Capacity (L/s)
- n = Manning coefficient of roughness (0.013)
- A_p = Pipe flow area (m²)
- R = Hydraulic Radius of wetted area (dia./4 for full pipes)
- S_o = Pipe slope/gradient

STORM SEWER DESIGN SHEET



520 & 570 March Road - Nokia Ottawa Innovation Campus
Southern Outlet through KRP Lands
1:5 Year Storm Event

Novatech Project #: 123043

Project Name: Nokia Ottawa Innovation Campus

Date: 11/15/2024

Input By: KD

Reviewed By: FST

Drawing Reference: C501

Storm Design Event = 5 Year

Legend:

- Design Input by User
- As-Built Input by User
- Cumulative Cell
- Calculated Design Cell Output
- Calculated Uncontrolled Peak Flow Cell Output
- Design Input Restricted Peak Flow Cell

Reference: City of Ottawa - Sewer Design Guidelines (2012 and TBs)
 MOE - Design Guidelines for Sewage Works (2008)

Location				Flow								Design Capacity								
												Proposed Sewer Pipe Sizing / Design								
Location	Area ID	From MH	To MH	Area A (ha.)	Runoff Coefficient C	Indivi. 2.78 AC	Accum. 2.78 AC	Time of Conc. Tc (min.)	Rain Intensity I (mm/hr)	Total Uncontrolled Peak Flow Q (L/s)	Total Restricted Peak Flow (L/s)	Pipe Length (m)	Pipe Size (mm) and Material	Pipe ID Actual (m)	Roughness n	Design Grade So (%)	Capacity Qfull (L/s)	Full Flow Velocity (m/s)	Time of Flow (min.)	Q / Qfull
Legget Drive	B-1	Lab Building	CBMH 266	0.80	0.90	1.99	1.99	10.00	104.19	207.2		1.0	450 PVC	0.4572	0.013	1.00	297.4	1.81	0.01	69.7%
Legget Drive	B-1	CBMH 266	STMMH 118	0.00	0.90	0.00	0.00	10.01	104.14	Flows controlled by ICD	43.0	2.7	300 PVC	0.3048	0.013	0.35	59.7	0.82	0.06	72.0%
Legget Drive	B-1	STMMH 118	EX STMMH L1	0.00	0.90	0.00	0.00	10.06	103.85		43.0	10.3	525 CONC	0.5334	0.013	0.18	190.3	0.85	0.20	22.6%
Legget Drive	B-0a, B-1, L-1	EX STMMH L1	EX STMMH L2	0.39	0.52	0.56	0.56	10.27	102.81		43.0	65.6	525 CONC	0.5334	0.013	0.20	200.6	0.90	1.22	50.3%
Legget Drive	B-0a, B1, L1-2	EX STMMH L2	EX STMMH L3	0.21	0.55	0.32	0.88	11.48	96.96		43.0	72.4	525 CONC	0.5334	0.013	0.17	185.0	0.83	1.46	69.6%
570 March Road	B-2	CB 201	CBMH 252	0.01	0.66	0.02	0.02	10.00	104.19		2.3	10.5	250 PVC	0.254	0.013	0.35	36.7	0.72	0.24	6.3%
570 March Road	B-2	CBMH 252	SWM TANK	0.04	0.66	0.08	0.10	10.24	102.93		10.2	8.7	250 PVC	0.254	0.013	0.35	36.7	0.72	0.20	27.7%
570 March Road	B-2	SWM TANK	CBMH 254	0.00	-	0.00	0.10	10.44	101.92		10.2	11.3	300 PVC	0.3048	0.013	0.35	59.7	0.82	0.23	17.0%
570 March Road	B-2	CB 207	CBMH 253	0.08	0.66	0.14	0.14	10.00	104.19		14.8	14.3	300 PVC	0.3048	0.013	0.35	59.7	0.82	0.29	24.7%
570 March Road	B-2	CBMH 253	CBMH 254	0.10	0.66	0.18	0.32	10.29	102.68		33.4	5.7	300 PVC	0.3048	0.013	0.35	59.7	0.82	0.12	55.9%
570 March Road	B-2	CBMH 254	CBMH 257	0.01	0.66	0.02	0.44	10.67	100.77		45.9	14.2	300 PVC	0.3048	0.013	0.35	59.7	0.82	0.29	76.9%
570 March Road	B-2	CB 206	CBMH 255	0.03	0.66	0.06	0.06	10.00	104.19		6.5	7.0	300 PVC	0.3048	0.013	0.35	59.7	0.82	0.14	10.9%
570 March Road	B-2	CBMH 255	CBMH 256	0.04	0.66	0.07	0.13	10.14	103.45		13.6	21.7	300 PVC	0.3048	0.013	0.35	59.7	0.82	0.44	22.8%
570 March Road	B-2	LD 1	CBMH 256	0.04	0.66	0.08	0.08	10.00	104.19		7.8	9.7	250 PVC	0.254	0.013	0.35	36.7	0.72	0.22	21.4%
570 March Road	B-2	CBMH 256	CBMH 257	0.04	0.66	0.08	0.28	10.58	101.20		21.2	22.1	300 PVC	0.3048	0.013	0.35	59.7	0.82	0.45	35.6%
570 March Road	B-2	CBMH 257	CBMH 258	0.07	0.66	0.13	0.86	10.96	99.38		80.5	28.2	375 PVC	0.381	0.013	0.35	108.2	0.95	0.50	74.4%
570 March Road	B-2	CBMH 258	CBMH 259	0.05	0.66	0.10	0.96	11.46	97.08		89.7	16.8	375 PVC	0.381	0.013	0.35	108.2	0.95	0.30	82.9%
570 March Road	B-2	CBMH 259	CBMH 260	0.01	0.66	0.02	0.97	11.75	95.77		91.3	60.5	375 PVC	0.381	0.013	0.35	108.2	0.95	1.06	84.4%
570 March Road	B-2	CBMH 260	STMMH 107	0.09	0.66	0.17	1.14	12.81	91.36	Flows controlled by ICD	48.0	7.3	375 PVC	0.381	0.013	0.35	108.2	0.95	0.13	44.4%
570 & 520 March Road	B-2	STMMH 107	STMMH 108	0.00	-	0.00	1.14	12.94	90.85		48.0	97.9	375 PVC	0.381	0.013	0.35	108.2	0.95	1.72	44.4%
Access Route	B-2	STMMH 108	STMMH 109	0.00	-	0.00	1.14	14.66	84.67		48.0	65.6	375 PVC	0.381	0.013	0.35	108.2	0.95	1.15	44.4%
520 March Road	C-1	CB 208	STMMH 109	0.64	0.20	0.36	0.36	10.00	104.19	Flows controlled by ICD	28.0	10.7	300 PVC	0.3048	0.013	0.35	59.7	0.82	0.22	46.9%
Access Route	B-2, C-1	STMMH 109	STMMH 111	0.00	-	0.00	1.50	15.81	81.02		76.0	23.0	450 PVC	0.4572	0.013	0.35	176.0	1.07	0.36	43.2%
570 March Road	B-3	Parking Garage	SWM TANK	1.00	0.90	2.51	2.51	10.00	104.19		261.7	1.6	375 PVC	0.381	0.013	1.00	365.8	1.60	0.02	71.5%
570 March Road	B-3	SWM TANK	STMMH 110	0.00	-	0.00	2.51	10.02	104.11		261.7	3.8	375 PVC	0.381	0.013	0.35	108.2	0.95	0.07	241.8%
570 March Road	B-3	STMMH 110	STMMH 111	0.19	0.86	0.44	2.95	10.08	103.75	Flows controlled by ICD	45.0	24.5	375 PVC	0.381	0.013	0.35	108.2	0.95	0.43	41.6%
Access Route	B2-B3, C-1	STMMH 111	STMMH 112	0.00	-	0.00	0.00	16.17	79.96		121.0	5.5	450 PVC	0.4572	0.013	0.35	176.0	1.07	0.09	68.8%
Access Route	C-2	CBMH 261	STMMH 112	0.08	0.90	0.19	0.19	10.00	104.19	Flows controlled by ICD	6.0	22.3	300 PVC	0.3048	0.013	0.35	59.7	0.82	0.45	10.1%
Access Route	B2-B3, C1-C2	STMMH 112	STMMH 113	0.00	-	0.00	0.19	16.26	79.71		127.0	58.3	450 PVC	0.4572	0.013	0.35	176.0	1.07	0.91	72.2%
Access Route	B2-B3, C1-C2	STMMH 113	STMMH 114	0.00	-	0.00	0.19	17.16	77.16		127.0	25.3	450 PVC	0.4572	0.013	0.35	176.0	1.07	0.39	72.2%
Access Route	B2-B3, C1-C2	STMMH 114	OGS UNIT 2	0.00	-	0.00	0.19	17.56	76.12		127.0	11.3	450 PVC	0.4572	0.013	0.35	176.0	1.07	0.18	72.2%

STORM SEWER DESIGN SHEET



Location				Flow								Design Capacity								
Location	Area ID	From MH	To MH	Area A (ha.)	Runoff Coefficient C	Indivi. 2.78 AC	Accum. 2.78 AC	Time of Conc. Tc (min.)	Rain Intensity I (mm/hr)	Total Uncontrolled Peak Flow Q (L/s)	Total Restricted Peak Flow (L/s)	Proposed Sewer Pipe Sizing / Design								
												Pipe Length (m)	Pipe Size (mm) and Material	Pipe ID Actual (m)	Roughness n	Design Grade So (%)	Capacity Qfull (L/s)	Full Flow Velocity (m/s)	Time of Flow (min.)	Q / Qfull
Access Route	B-4	CB 211	CBMH 262	0.24	0.88	0.60	0.60	10.00	104.19	62.1		25.7	375 PVC	0.381	0.013	0.35	108.2	0.95	0.45	57.4%
Access Route	B-4	CBMH 262	CBMH 263	0.25	0.88	0.62	1.21	10.45	101.87	124.8		10.4	450 PVC	0.4572	0.013	0.35	176.0	1.07	0.16	70.9%
Access Route	B-4	CBMH 263	STMMH 116	0.18	0.88	0.45	1.66	10.61	101.06	169.9		12.9	450 PVC	0.4572	0.013	0.45	199.5	1.22	0.18	85.2%
Access Route	B-4	STMMH 115	STMMH 116	0.08	0.88	0.19	0.19	10.00	104.19	19.6		8.4	375 PVC	0.381	0.013	0.35	108.2	0.95	0.15	18.1%
Access Route	B-4	STMMH 116	OGS UNIT 2	0.00	-	0.00	1.85	10.79	100.20	Flows controlled by ICD	38.0	12.6	375 PVC	0.381	0.013	0.35	108.2	0.95	0.22	35.1%
Access Route/Legget Drive	B2-B4, C1-C2	OGS UNIT 2	EX. STMMH L3	0.00	-	0.00	2.03	17.73	75.66		165.0	12.9	450 PVC	0.4572	0.013	0.35	176.0	1.07	0.20	93.8%
Legget Drive	B-0b, C-0, S-1	EX. STMMH L4	EX. STMMH L3	2.14	0.72	4.25	4.25	14.30	85.89	Flows controlled by ICD	167.7	18.3	600 CONC	0.6096	0.013	0.33	368.0	1.26	0.24	45.6%
Legget Drive	B0-4, C0-4, L1-2, S-1	EX. STMMH L3	EX. STMMH "A"	0.00	-	0.00	0.00	17.93	75.14	85.8	375.7	30.0	825 CONC	0.8382	0.013	0.50	1058.9	1.92	0.26	43.6%
525 Legget Drive (KRP)	B0-4, C0-4, L1-2, S-1	EX. STMMH "A"	EX. STMMH "B"	0.00	-	0.00	0.00	18.19	74.48	85.8	375.7	50.1	825 CONC	0.8382	0.013	0.50	1058.9	1.92	0.44	43.6%
525 Legget Drive (KRP)	B0-4, C0-4, L1-2, S-1	EX. STMMH "B"	EX. STMMH "C"	0.00	-	0.00	0.00	18.63	73.41	85.8	375.7	46.8	825 CONC	0.8382	0.013	0.50	1058.9	1.92	0.41	43.6%
525 Legget Drive (KRP)	B0-4, C0-4, L1-2, S-1	EX. STMMH "C"	EX. STMMH "D"	0.00	-	0.00	0.00	19.03	72.44	85.8	375.7	12.8	825 CONC	0.8382	0.013	1.00	1497.5	2.71	0.08	30.8%
525 Legget Drive (KRP)	TC1-TC5	EX. CBMH	EX. STMMH "D"	1.31	0.82	2.99	2.99	10.00	104.19	311.9		53.9	600 PVC	0.7096	0.013	0.17	396.0	1.00	0.90	78.8%
525 Legget Drive (KRP)	B0-4, C0-4, L1-2, S-1, TC1-5	EX. STMMH "D"	EX. STMMH "E"	0.00	-	0.00	2.99	19.11	72.26	397.7	375.7	15.3	900 CONC	0.9144	0.013	0.27	981.3	1.49	0.17	78.8%
525 Legget Drive (KRP)	TD-1	EX. CBMH	EX. STMMH "E"	0.84	0.75	1.75	1.75	10.00	104.19	182.5		49.0	300 PVC	0.3048	0.013	1.60	127.6	1.75	0.47	143.0%
525 Legget Drive (KRP)	B0-4, C0-4, L1-2, S1, TC1-5, TD-1	EX. STMMH "E"	EX. STMMH "F"	0.00	-	0.00	4.75	19.28	71.86	341.0	375.7	37.5	900 CONC	0.9144	0.013	0.20	844.6	1.29	0.49	84.9%
515 Legget Drive (KRP)	TD-2	Building	EX. STMMH "F"	0.14	0.90	0.35	0.35	10.00	104.19	36.5		38.0	200 PVC	0.2032	0.013	0.30	18.7	0.58	1.10	194.7%
525 Legget Drive (KRP)	H-1	Hotel	EX. STMMH "F"	0.72	0.85	1.70	1.70	10.00	104.19	177.3		15.5	200 PVC	0.2032	0.013	0.71	28.8	0.89	0.29	614.9%
525 Legget Drive (KRP)	B0-4, C0-4, L1-2, S1, TC1-5, TD1-2	EX. STMMH "F"	EX. STMMH "G"	0.00	-	0.00	6.80	19.77	70.76	480.9	375.7	64.8	900 CONC	0.9144	0.013	0.48	1308.4	1.99	0.54	65.5%
515 Legget Drive (KRP)	TD-3, TD-4	EX. CBMH	EX. STMMH "G"	2.84	0.75	5.92	5.92	10.00	104.19	617.0		79.0	450 CONC	0.4572	0.013	0.50	210.3	1.28	1.03	293.4%
525 Legget Drive (KRP)	B0-4, C0-4, L1-2, S1, TC1-5, TD1-4, H-1	EX. STMMH "G"	EX. STMMH "H"	0.00	-	0.00	12.72	20.31	69.57	884.9	375.7	22.5	975 CONC	0.9906	0.013	1.20	2561.1	3.32	0.11	49.2%
525 Legget Drive (KRP)	B0-4, C0-4, L1-2, S1, TC1-5, TD1-4, H-1	EX. STMMH "H"	EX. STMMH "I"	0.00	-	0.00	12.72	20.42	69.33	884.9	375.7	46.8	1050 CONC	1.0668	0.013	0.24	1395.6	1.56	0.50	90.3%
525 Legget Drive (KRP)	B0-4, C0-4, L1-2, S1, TC1-5, TD1-4, H-1	EX. STMMH "I"	SWM POND	0.00	-	0.00	12.72	20.92	68.29	884.9	375.7	42.9	1050 CONC	1.0668	0.013	0.44	1889.7	2.11	0.34	66.7%
Totals				11.87								1444.9								

Demand Equation / Parameters

1. Q = 2.78 ACI

Definitions

- Q = Peak flow in litres per second (L/s)
- A = Area in hectares (ha)
- C = Weighted runoff coefficient (increased by 25% for 100-year)
- I = Rainfall intensity in millimeters per hour (mm/hr)

Rainfall intensity is based on City of Ottawa IDF data presented in the City of Ottawa - Sewer Design Guidelines

Notes

- 1) Refer to the Novatech Report "Development Servicing Study and Stormwater Management Report - Nokia Ottawa Innovation Campus" (R-2023-082) for on-site storm drainage and stormwater details.
- 2) Refer to the Novatech Report "Sanitary and Storm Trunk Sewer Design Brief - Nokia Ottawa Innovation Campus" (R-2024-130) for off-site storm drainage and stormwater details.
- 3) Refer to Novatech Drawings C100 and C501 for the storm structure designations, storm pipe details and control structure tables.
- 4) Refer to Novatech Drawing C500 and associated storm sewer design sheet for STM drainage areas that contribute to the northern STM Sewer on KRP Lands.

Capacity Equation

$$Q_{full} = 1000 \cdot (1/n) \cdot A_p \cdot R^{2/3} \cdot So^{0.5}$$

Definitions

- Q full = Capacity (L/s)
- n = Manning coefficient of roughness (0.013)
- A_p = Pipe flow area (m²)
- R = Hydraulic Radius of wetted area (dia./4 for full pipes)
- So = Pipe slope/gradient

2024-10-25

City of Ottawa
110 Laurier Avenue West
Ottawa, ON
K1P 1J1

Attention: City Building Official

**RE: 570 MARCH ROAD – NOKIA OTTAWA CAMPUS
S+A PROJECT # 20508.013
FLOW CONTROL ROOF DRAINAGE DECLARATION**

Dear City Building Official:

This letter is to confirm that areas of the Nokia campus roof will be designed with both Conventionally drained roof areas and flow controlled roof areas, per the SWM report provided by Novatech.

Where flow control drains are used, we will coordinate the design to meet the following conditions:

- a) the maximum drain down time does not exceed 24h,
- b) one or more scuppers are installed so that the maximum depth of water on the roof cannot exceed 150mm,
- c) drains are located not more than 15m from the edge of roof and not more than 30m from adjacent drains, and
- d) there is at least one drain for each 900 sq.m

Yours truly,

SMITH + ANDERSEN



Elaine Guenette, P.Eng.
Principal



20508.013 Flow Control Drainage.docx

APPENDIX F

Inlet Control Device (ICD) Information

IPEX Tempest™ Inlet Control Devices

Municipal Technical Manual Series

Vol. I, 2nd Edition

© 2012 by IPEX. All rights reserved. No part of this book may be used or reproduced in any manner whatsoever without prior written permission. For information contact: IPEX, Marketing, 2441 Royal Windsor Drive, Mississauga, Ontario, Canada, L5J 4C7.

The information contained here within is based on current information and product design at the time of publication and is subject to change without notification. IPEX does not guarantee or warranty the accuracy, suitability for particular applications, or results to be obtained therefrom.

PRODUCT TECHNICAL SPECIFICATION

General

Inlet control devices (ICD's) are designed to provide flow control at a specified rate for a given water head level and also provide odour and floatable control. All ICD's will be IPEX Tempest or approved equal.

All devices shall be removable from a universal mounting plate. An operator from street level using only a T-bar with a hook will be able to retrieve the device while leaving the universal mounting plate secured to the catch basin wall face. The removal of the TEMPEST devices listed above must not require any unbolting or special manipulation or any special tools.

High Flow (HF) Sump devices will consist of a removable threaded cap which can be accessible from street level with out entry into the catchbasin (CB). The removal of the threaded cap shall not require any special tools other than the operator's hand.

ICD's shall have no moving parts.

Materials

ICD's are to be manufactured from Polyvinyl Chloride (PVC) or Polyurethane material, designed to be durable enough to withstand multiple freeze-thaw cycles and exposure to harsh elements.

The inner ring seal will be manufactured using a Buna or Nitrile material with hardness between Duro 50 and Duro 70.

The wall seal is to be comprised of a 3/8" thick Neoprene Closed Cell Sponge gasket which is attached to the back of the wall plate.

All hardware will be made from 304 stainless steel.

Dimensioning

The Low Medium Flow (LMF), High Flow (HF) and the High Flow (HF) Sump shall allow for a minimum outlet pipe diameter of 200mm with a 600mm deep Catch Basin sump.

Installation

Contractor shall be responsible for securing, supporting and connecting the ICD's to the existing influent pipe and catchbasin/manhole structure as specified and designed by the Engineer.

PRODUCT INFORMATION: TEMPEST HF & MHF ICD

Product Description

Our HF, HF Sump and MHF ICD's are designed to accommodate catch basins or manholes with sewer outlet pipes 6" in diameter or larger. Any storm sewer larger than 12" may require custom modification. However, IPEX can custom build a TEMPEST device to accommodate virtually any storm sewer size.

Available in 5 preset flow curves, these ICDs have the ability to provide constant flow rates: 9lps (143 gpm) and greater

Product Function

TEMPEST HF (High Flow): designed to manage moderate to higher flows 15 L/s (240 gpm) or greater and prevent the propagation of odour and floatables. With this device, the cross-sectional area of the device is larger than the orifice diameter and has been designed to limit head losses. The HF ICD can also be ordered without flow control when only odour and floatable control is required.



TEMPEST HF (High Flow) Sump: The height of a sewer outlet pipe in a catch basin is not always conveniently located. At times it may be located very close to the catch basin floor, not providing enough sump for one of the other TEMPEST ICDs with universal back plate to be installed. In these applications, the HF Sump is offered. The HF Sump offers the same features and benefits as the HF ICD; however, is designed to raise the outlet in a square or round catch basin structure. When installed, the HF sump is fixed in place and not easily removed. Any required service to the device is performed through a clean-out located in the top of the device which can be often accessed from ground level.

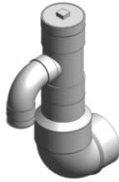

TEMPEST MHF (Medium to High Flow):

The MHF plate or plug is designed to control flow rates 9 L/s (143 gpm) or greater. It is not designed to prevent the propagation of odour and floatables.



Product Construction

The HF, HF Sump and MHF ICDs are built to be light weight at a maximum weight of 6.8 Kg (14.6 lbs).

Product Applications

The HF and MHF ICD's are available to accommodate both square and round applications:

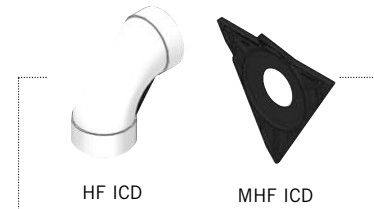

Square Application

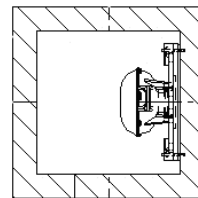

Round Application

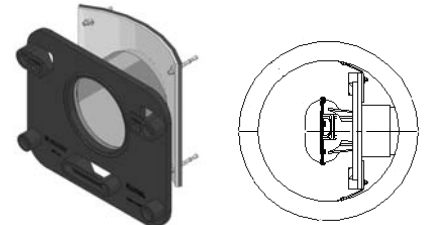
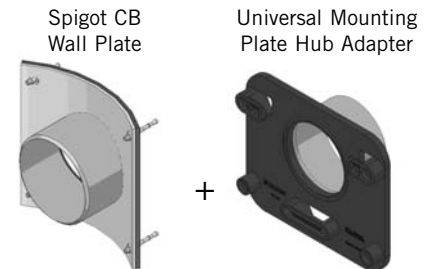

The HF Sump is available to accommodate low to no sump applications in both square and round catch basins:

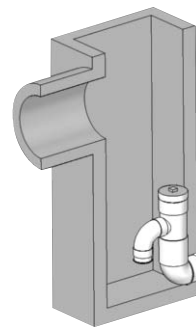

Square Catch Basin

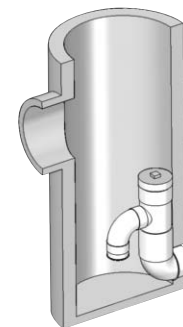

Round Catch Basin

Chart 3: HF & MHF Preset Flow Curves

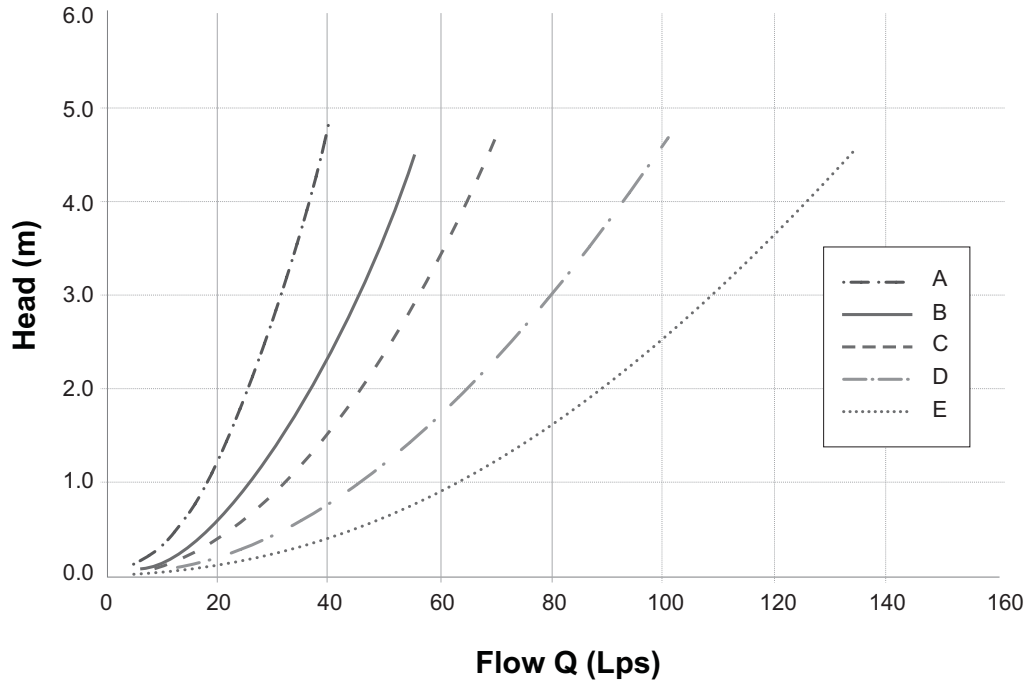

TEMPEST
 HF & MHF ICD

PRODUCT INSTALLATION

Instructions to assemble a TEMPEST HF or MHF ICD into a Square Catch Basin:

1. Materials and tooling verification:
 - Tooling: impact drill, 3/8" concrete bit, torque wrench for 9/16" nut, hand hammer, level, and marker.
 - Material: (4) concrete anchor 3/8 x 3-1/2, (4) washers, (4) nuts, universal mounting plate, ICD device
2. Use the mounting wall plate to locate and mark the hole (4) pattern on the catch basin wall. You should use a level to ensure that the plate is at the horizontal.
3. Use an impact drill with a 3/8" concrete bit to make the four holes at a minimum of 1-1/2" depth up to 2-1/2". Clean the concrete dust from the holes.
4. Install the anchors (4) in the holes by using a hammer. Thread the nuts on the top of the anchors to protect the threads when you hit the anchors with the hammer. Remove the nuts from the ends of the anchors.
5. Install the universal wall mounting plate on the anchors and screw the 4 nuts in place with a maximum torque of 40 N.m (30 lbf-ft). There should be no gap between the wall mounting plate and the catch basin wall.
6. From the ground above using a reach bar, lower the device by hooking the end of the reach bar to the handle of the ICD device. Align the triangular plate portion into the mounting wall plate. Push down the device to be sure it has centered in to the universal wall mounting plate and has created a seal.



WARNING

- Verify that the outlet pipe doesn't protrude into the catch basin. If it does, cut down the pipe flush to the catch basin wall.
- Call your IPEX representative for more information or if you have any questions about our products.

Instructions to assemble a TEMPEST HF or MHF ICD into a Round Catch Basin:

STEPS:

1. Materials and tooling verification.
 - Tooling: impact drill, 3/8" concrete bit, torque wrench for 9/16" nut, hand hammer, level and marker.
 - Material: (4) concrete anchor 3/8 x 3-1/2, (4) washers and (4) nuts, spigot CB wall plate, universal mounting plate hub adaptor, ICD device.
2. Use the round catch basin spigot adaptor to locate and mark the hole (4) pattern on the catch basin wall. You should use a level to ensure that the plate is at the horizontal.
3. Use an impact drill with a 3/8" concrete bit to make the four holes at a depth between 1-1/2" to 2-1/2". Clean the concrete dust from the holes.
4. Install the anchors (4) in the holes by using a hammer. Thread the nuts on the top of the anchors to protect the threads when you hit the anchors with the hammer. Remove the nuts from the ends of the anchors.
5. Install the spigot CB wall plate on the anchors and screw the 4 nuts in place with a maximum torque of 40 N.m (30 lbf-ft). There should be no gap between the spigot CB wall plate and the catch basin wall.
6. Put solvent cement on the hub of the universal mounting plate, hub adaptor and the spigot of the CB wall plate, then slide the hub over the spigot. Make sure the universal mounting plate is at the horizontal and its hub is completely inserted onto the spigot. Normally, the corners of the hub adaptor should touch the catch basin wall.
7. From ground above using a reach bar, lower the device by hooking the end of the reach bar to the handle of the ICD device. Align the triangular plate portion into the mounting wall plate. Push down the device to be sure it has centered in to the wall mounting plate and has created a seal.



WARNING

- Verify that the outlet pipe doesn't protrude into the catch basin. If it does, cut down the pipe flush to the catch basin wall.
- The solvent cement which is used in this installation is to be approved for PVC.
- The solvent cement should not be used below 0°C (32°F) or in a high humidity environment. Refer to the IPEX solvent cement guide to confirm the required curing time or visit the IPEX Online Solvent Cement Training Course available at www.ipexinc.com.
- Call your IPEX representative for more information or if you have any questions about our products.

Instructions to assemble a TEMPEST HF Sump into a Square or Round Catch Basin:

STEPS:

1. Materials and tooling verification:
 - Tooling: impact drill, 3/8" concrete bit, torque wrench for 9/16" nut, hand hammer, level, mastic tape and metal strapping
 - Material: (2) concrete anchor 3/8 x 3-1/2, (2) washers, (2) nuts, HF Sump pieces (2).
2. Apply solvent cement to the spigot end of the top half of the sump. Apply solvent cement to the hub of the bottom half of the sump. Insert the spigot of the top half of the sump into the hub of the bottom half of the sump.
3. Install the 8" spigot of the device into the outlet pipe. Use the mastic tape to seal the device spigot into the outlet pipe. You should use a level to be sure that the fitting is standing at the vertical.
4. Use an impact drill with a 3/8" concrete bit to make a series of 2 holes along each side of the body throat. The depth of the hole should be between 1-1/2" to 2-1/2". Clean the concrete dust from the 2 holes.
5. Install the anchors (2) in the holes by using a hammer. Put the nuts on the top of the anchors to protect the threads when you hit the anchors. Remove the nuts from the ends of the anchors.
6. Cut the metal strapping to length and connect each end of the strapping to the anchors. Screw the nuts in place with a maximum torque of 40 N.m (30 lbf-ft). The device should be completely flush with the catch basin wall.



WARNING

- Verify that the outlet pipe doesn't protrude into the catch basin. If it does, cut down the pipe flush to the catch basin wall.
- The solvent cement which is used in this installation is to be approved for PVC.
- The solvent cement should not be used below 0°C (32°F) or in a high humidity environment. Refer to the IPEX solvent cement guide to confirm the required curing time or visit the IPEX Online Solvent Cement Training Course available at www.ipexinc.com.
- Call your IPEX representative for more information or if you have any questions about our products.

PRODUCT TECHNICAL SPECIFICATION

General

Inlet control devices (ICD's) are designed to provide flow control at a specified rate for a given water head level and also provide odour and floatable control where specified. All ICD's will be IPEX Tempest or approved equal.

All devices shall be removable from a universal mounting plate. An operator from street level using only a T-bar with a hook shall be able to retrieve the device while leaving the universal mounting plate secured to the catch basin wall face. The removal of the TEMPEST devices listed above shall not require any unbolting or special manipulation or any special tools.

High Flow (HF) Sump devices shall consist of a removable threaded cap which can be accessible from street level with out entry into the catchbasin (CB). The removal of the threaded cap shall not require any special tools other than the operator's hand.

ICD's shall have no moving parts.

Materials

ICD's are to be manufactured from Polyvinyl Chloride (PVC) or Polyurethane material, designed to be durable enough to withstand multiple freeze-thaw cycles and exposure to harsh elements.

The inner ring seal will be manufactured using a Buna or Nitrile material with hardness between Duro 50 and Duro 70.

The wall seal is to be comprised of a 3/8" thick Neoprene Closed Cell Sponge gasket which is attached to the back of the wall plate.

All hardware will be made from 304 stainless steel.

Dimensioning

The Low Medium Flow (LMF), High Flow (HF) and the High Flow (HF) Sump shall allow for a minimum outlet pipe diameter of 200mm with a 600mm deep Catch Basin sump.

Installation

Contractor shall be responsible for securing, supporting and connecting the ICD's to the existing influent pipe and catchbasin/manhole structure as specified and designed by the Engineer.

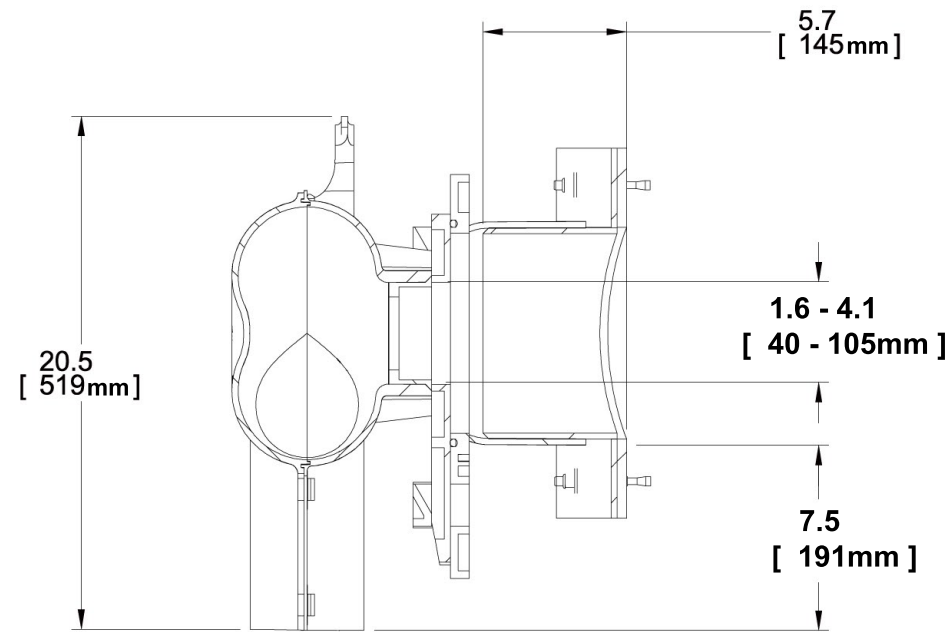
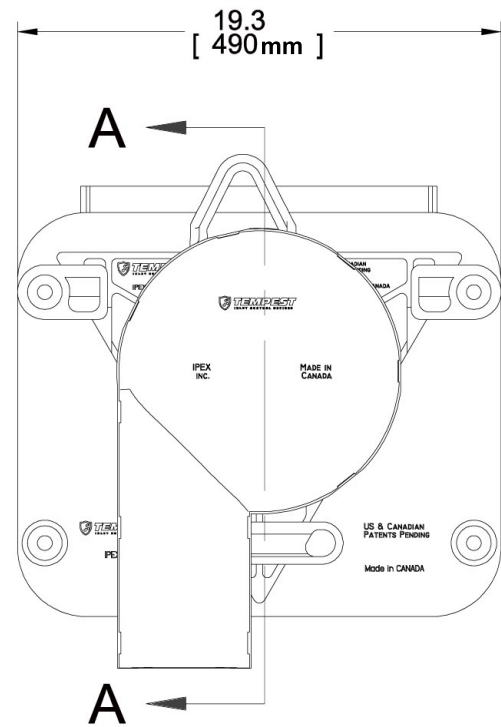
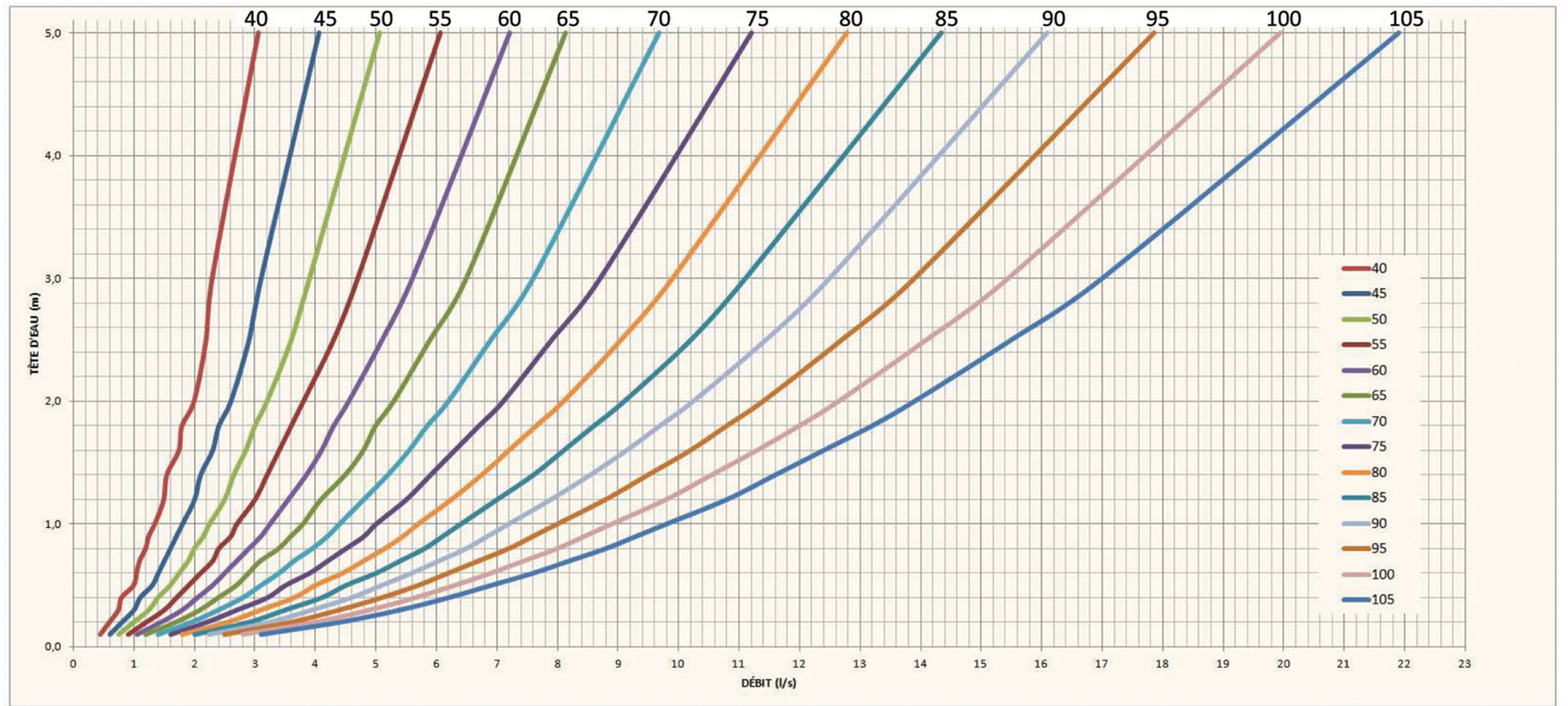
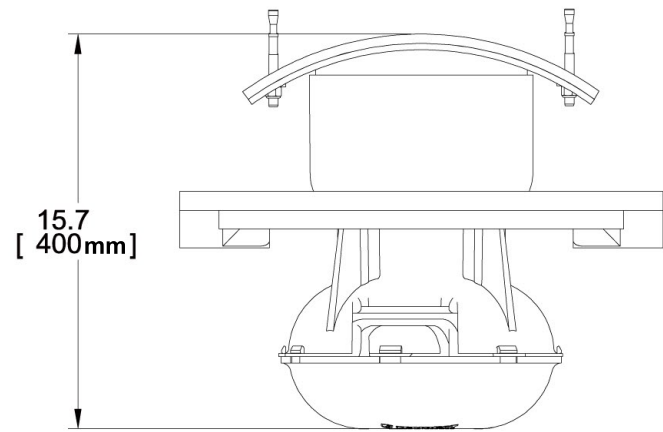

SECTION A-A

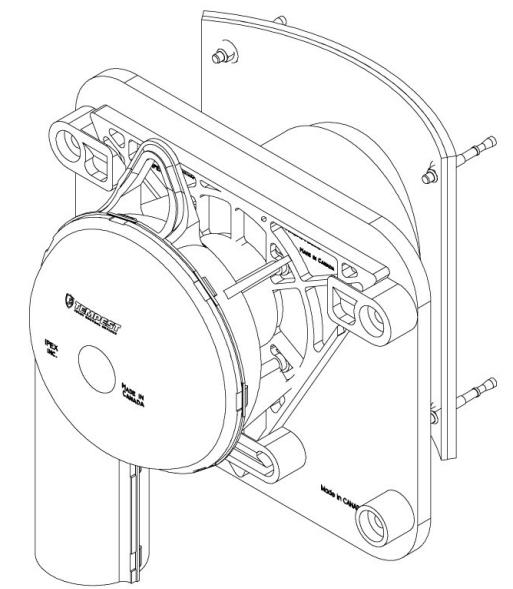

APPENDIX G

Control Flow Roof Drain Information



Adjustable Accutrol Weir

Tag: _____

Adjustable Flow Control for Roof Drains

ADJUSTABLE ACCUTROL (for Large Sump Roof Drains only)

For more flexibility in controlling flow with heads deeper than 2", Watts Drainage offers the Adjustable Accutrol. The Adjustable Accutrol Weir is designed with a single parabolic opening that can be covered to restrict flow above 2" of head to less than 5 gpm per inch, up to 6" of head. To adjust the flow rate for depths over 2" of head, set the slot in the adjustable upper cone according to the flow rate required. Refer to Table 1 below.
 Note: Flow rates are directly proportional to the amount of weir opening that is exposed.

EXAMPLE:

For example, if the adjustable upper cone is set to cover 1/2 of the weir opening, flow rates above 2" of head will be restricted to 2-1/2 gpm per inch of head.

Therefore, at 3" of head, the flow rate through the Accutrol Weir that has 1/2 the slot exposed will be:
 [5 gpm (per inch of head) x 2 inches of head] + 2-1/2 gpm (for the third inch of head) = 12-1/2 gpm.

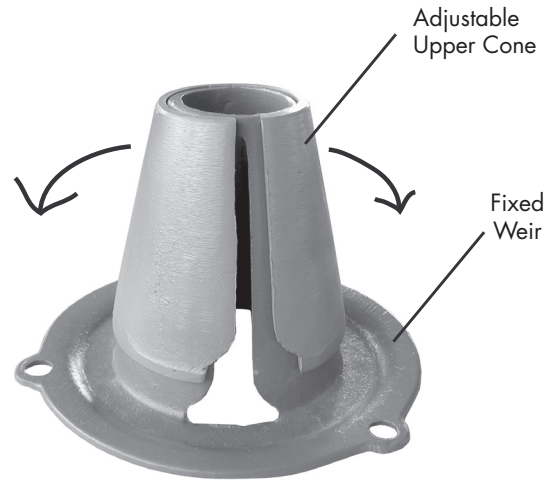
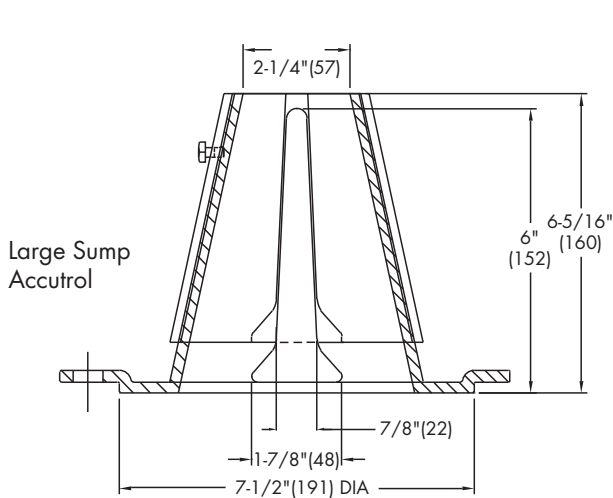

1/2 Weir Opening Exposed Shown Above

TABLE 1. Adjustable Accutrol Flow Rate Settings

Weir Opening Exposed	1"	2"	3"	4"	5"	6"
	Flow Rate (gallons per minute)					
Fully Exposed	5	10	15	20	25	30
3/4	5	10	13.75	17.5	21.25	25
1/2	5	10	12.5	15	17.5	20
1/4	5	10	11.25	12.5	13.75	15
Closed	5	5	5	5	5	5

Job Name _____
 Job Location _____
 Engineer _____

Contractor _____
 Contractor's P.O. No. _____
 Representative _____

Watts product specifications in U.S. customary units and metric are approximate and are provided for reference only. For precise measurements, please contact Watts Technical Service. Watts reserves the right to change or modify product design, construction, specifications, or materials without prior notice and without incurring any obligation to make such changes and modifications on Watts products previously or subsequently sold.

USA: Tel: (800) 338-2581 • Fax: (828) 248-3929 • Watts.com
 Canada: Tel: (905) 332-4090 • Fax: (905) 332-7068 • Watts.ca
 Latin America: Tel: (52) 81-1001-8600 • Fax: (52) 81-8000-7091 • Watts.com



APPENDIX H

Underground Stormwater Storage Chamber Information

StormTech[®] MC-3500 Chamber

Designed to meet the most stringent industry performance standards for superior structural integrity while providing designers with a cost-effective method to save valuable land and protect water resources. The StormTech system is designed primarily to be used under parking lots, thus maximizing land usage for private (commercial) and public applications. StormTech chambers can also be used in conjunction with Green Infrastructure, thus enhancing the performance and extending the service life of these practices.

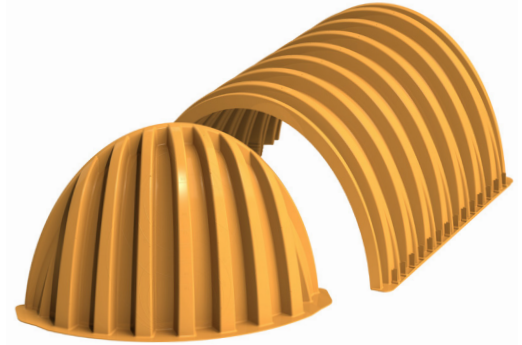

Nominal Chamber Specifications (not to scale)

Size (L x W x H)
 90" x 77" x 45"
 2286 mm x 1956 mm x 1143 mm

Chamber Storage
 109.9 ft³ (3.11 m³)

Min. Installed Storage*
 175.0 ft³ (4.96 m³)

Weight
 134 lbs (60.8 kg)

Shipping
 15 chambers/pallet
 7 end caps/pallet
 7 pallets/truck

*Assumes a minimum of 12" (300 mm) of stone above, 9" (230 mm) of stone below chambers, 6" (150 mm) of stone between chambers/ end caps and 40% stone porosity.

Nominal End Cap Specifications (not to scale)

Size (L x W x H)
 26.5" x 71" x 45.1"
 673 mm x 1803 mm x 1145 mm

End Cap Storage
 14.9 ft³ (0.42 m³)

Min. Installed Storage*
 45.1 ft³ (1.28 m³)

Weight
 49 lbs (22.2 kg)

*Assumes a minimum of 12" (300 mm) of stone above, 9" (230 mm) of stone below, 6" (150 mm) of stone perimeter, 6" (150 mm) of stone between chambers/ end caps and 40% stone porosity.

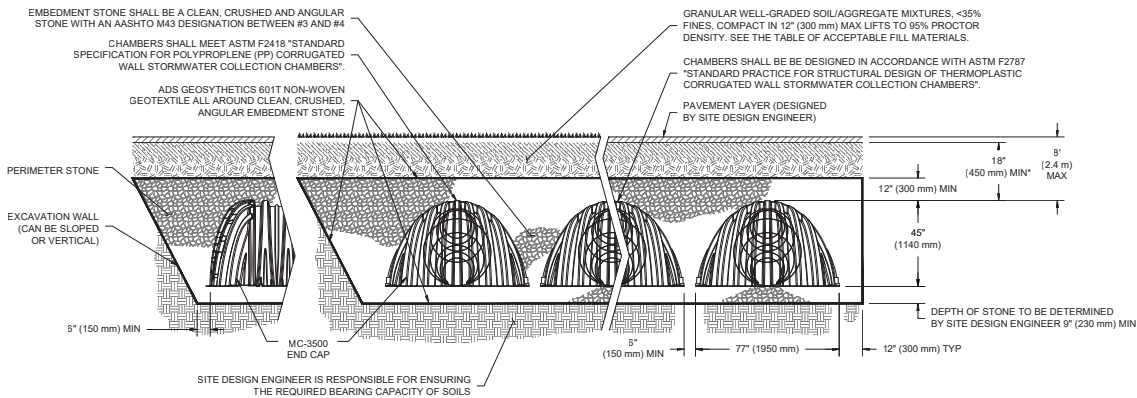
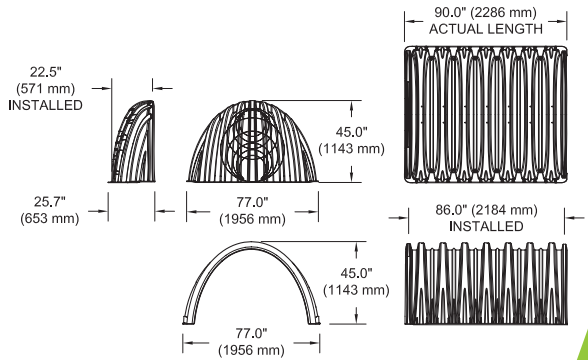

*MINIMUM COVER TO BOTTOM OF FLEXIBLE PAVEMENT. FOR UNPAVED INSTALLATIONS WHERE RUTTING FROM VEHICLES MAY OCCUR, INCREASE COVER TO 24" (600 mm).

StormTech MC-3500 Specifications

Storage Volume Per Chamber

	Bare Chamber Storage ft ³ (m ³)	Chamber and Stone Foundation Depth in. (mm)			
		9 in (230 mm)	12 in (300 mm)	15 in (375 mm)	18 in (450 mm)
Chamber	109.9 (3.11)	175.0 (4.96)	179.9 (5.09)	184.9 (5.24)	189.9 (5.38)
End Cap	14.9 (0.42)	45.1 (1.28)	46.6 (1.32)	48.3 (1.37)	49.9 (1.41)

Note: Assumes 6" (150 mm) row spacing, 40% stone porosity, 12" (300 mm) stone above and includes the bare chamber/end cap volume.

Amount of Stone Per Chamber

English Tons (yds ³)	Stone Foundation Depth			
	9 in	12 in	15 in	18 in
Chamber	8.5 (6.0)	9.1 (6.5)	9.7 (6.9)	10.4 (7.4)
End Cap	3.9 (2.8)	4.1 (2.9)	4.3 (3.1)	4.5 (3.2)
Metric Kilograms (m ³)	230 mm	300 mm	375 mm	450 mm
Chamber	7711 (4.6)	8255 (5.0)	8800 (5.3)	9435 (5.7)
End Cap	3538 (2.1)	3719 (2.2)	3901 (2.4)	4082 (2.5)

Note: Assumes 12" (300 mm) of stone above and 6" (150 mm) row spacing and 6" (150 mm) of perimeter stone in front of end caps.

Volume Excavation Per Chamber yd³ (m³)

	Stone Foundation Depth			
	9 in (230 mm)	12 in (300 mm)	15 in (375mm)	18 in (450 mm)
Chamber	11.9 (9.1)	12.4 (9.5)	12.8 (9.8)	13.3 (10.2)
End Cap	4.0 (3.1)	4.1 (3.3)	4.3 (3.3)	4.4 (3.4)

Note: Assumes 6" (150 mm) of separation between chamber rows and 24" (600 mm) of cover. The volume of excavation will vary as depth of cover increases.

ADS StormTech products, manufactured in accordance with ASTM F2418 or ASTM F2922, comply with all requirements in the Build America, Buy America (BABA) Act.

Working on a project?

Visit us at adspipe.com/stormtech and utilize the Design Tool



APPENDIX I

KRP Stormwater Drainage Brief Excerpts

**KANATA RESEARCH PARK
STORMWATER DRAINAGE
BRIEF**

Prepared for:
CITY OF KANATA

Prepared by:
NOVATECH ENGINEERING CONSULTANTS LTD.

December 11, 2000

Development sites in Area 1 that drain to Pond 1 include:

- Towers A, B, C, and Link between B and C
- The Hotel, Tower D and Tower D – Hotel Link
- Alcatel parking lot and future development area, both southwest of Leggett Drive
- By additional quality treatment, the 1.25 ha parking area adjacent to the Swansea Development

3.1 Tower A, B, C, And Link between B and C

As stated above, Towers ‘A’, ‘B’, ‘C’ and Link are located in Drainage Area 1 and SWM Pond 1 provides quantity and quality control for this development.

The storm sewer system that services these developments also services an Alcatel parking area and one future development area, both southwest of Leggett Drive.

As shown on the attached drawing, the overland flow route for the parking areas servicing Towers A and B has been intercepted by the link between Towers B and C. It is now intended to pipe the 100 year flows under the link via a 600 mm storm pipe (replacing the proposed 450 mm pipe). Summarized below are the storm sewer calculations that show the anticipated 100 year flows along with system capacity.

Tower A, B, C and Link - Major Flow Conditions							
From	To	Peak 100yr Flow(L/s)	Pipe Ø mm	Grade	Capacity	Q Q _{max}	Comments
Alcatel Parking	CBMH 5	63.8	375	0.55	135.7	47	Flow from Alcatel controlled to 63.8
CBMH 5	CBMH A	213.3	375	1.64	235	91	
CBMH A	CBMH B	210.0	600	0.3	350.8	60	
CB3	CBMH 4	104.0	300	0.5	71.33	146	No surcharging above T/G
CBMH 4	CBMH B	214.5	375	0.5	129.3	167	No surcharging above T/G
CBMH B	STMH A	425.1	600	1.0	640.6	66	New 600mm pipe under link
Tower B	STMH A	38.0	300	0.5	71.3	54	
STMH A	STMH 10	463.1	450	2.9	506.2	92	

As shown in the table above, very little pipe surcharging will occur and ponding in the parking area is not anticipated. As part of designing the link and adjacent parking area, the 600mm inlet will be graded to take all major system drainage from this area.

For CB3 above, ponding level is contingent on full flow control of the Alcatel parking lot to 62.8 L/s. A site inspection carried out December 8, 2000, by NECL staff verified that four of the six ICD devices were in place, however the ICD was missing on the last CBMH upstream of Leggett Drive. This lot is designed to cascade to this last catchbasin, so design quantity control, as identified in the SWM report for this site, has not been provided. Without this ICD, ponding of 0.32 m will occur at CBMH5 during the 100 year event.

SANITARY AND STORM TRUNK SEWER DESIGN BRIEF
KANATA RESEARCH PARK LANDS

Prepared By:

NOVATECH

Suite 200, 240 Michael Cowpland Drive
Ottawa, Ontario
K2M 1P6

August 8, 2014

Revised September 25, 2014

Issued to MOE November 12, 2014

Novatech File: 114060

Ref: R-2014-114

management facility (SWMF) No. 1 located on the KRP lands. This SWM pond was designed to accommodate flow from the drainage areas shown on the Storm Drainage Area Plan (98066-STM). An MOE Certificate of Approval (MOE C of A No. 8125-4MTJ36) was obtained for the SWMF. Refer to **Appendix A** for a copy of the MOE C of A.

Storm Sewer Design Sheets have been provided in **Appendix C** for the on-site storm sewer system and the trunk storm sewer system from Legget Drive to the existing Stormwater Management Facility No.1. The following list of sewers identifies the storm sewer reaches for which a new MOE ECA is required. Refer to the enclosed Storm Drainage Area Plan (114060-STM, C201) for details.

- From New STM MH 4 to New STM MH 3
- From New STM MH 3 to New STM MH 2
- From New STM MH 2 to New STM MH 1
- From New STM MH 1 to New STM MH 1A
- From New STM MH 1A to EX. STM MH 2
- From EX. STM MH 2 to EX. STM MH 3
- From EX. STM MH 3 to EX. STM MH D
- From EX. STM MH D to EX. STM MH 6
- From EX. STM MH 6 to EX. STM MH 4
- From EX. STM MH 4 to EX. SWMF No. 1

3.1 Storm Design Flows

Storm flows shown in the Storm Sewer Design Sheet were determined as described in the following section of the report. The properties on the west side of Legget Drive, including the subject site (500 March Road), require on-site detention as the developed sites exceed the allowable runoff coefficient of 0.75.

3.1.1 ***Newbridge Parking Lot***

Stormwater runoff from the paved parking lot is currently being controlled by an inlet control device (ICD) installed in the outlet pipe of CBMH 4 to a maximum release rate of 152 L/s prior to being directed into the existing storm sewer in Legget Drive. Refer to **Appendix D** for details regarding this previously constructed site.

3.1.2 ***Vacant Land (Future Parking south of Newbridge Parking Lot)***

Should the vacant land between the Newbridge Parking and the subject site (500 March Road) be developed in the future, flows will have to be controlled to a maximum release rate of 83.1 L/s prior to being discharged into the storm sewer in Legget Drive. Refer to **Appendix E** for detailed calculations.

3.1.3 ***Sites on the East side of Legget Drive***

The tributary flows from areas on the east side of Legget Drive were designed with actual runoff coefficients and did not require on-site detention. Data for these areas is provided in the enclosed Storm Sewer Design Sheets. Refer to **Appendix C** for details.

APPENDIX J
Engineering Drawings

LEGEND	
SAN MH 1	PROPOSED SANITARY MANHOLE AND SEWER
CBMH 250	PROPOSED CATCH-BASIN MANHOLE
STMMH 100	PROPOSED STORM MANHOLE AND SEWER
CB 200	PROPOSED CATCH-BASIN
LD 1	PROPOSED LANDSCAPE DRAIN
HYD	PROPOSED HYDRANT AND VALVE
VA	PROPOSED VALVE BOX
VC	PROPOSED VALVE CHAMBER
RED	PROPOSED REDUCER
SC	PROPOSED SIMASESE CONNECTION
DC	PROPOSED BARRIER CURB (PER S1C.1)
CC	PROPOSED DEPRESSED CURB (PER S1C.1)
CCJ	PROPOSED CURB CUT
ICD	PROPOSED INLET CONTROL DEVICE
FPE	PROPOSED FINISHED FLOOR ELEVATION
USF	PROPOSED UNDERSEAL OF FOOTING ELEVATION

- GENERAL NOTES:**
- COORDINATE AND SCHEDULE ALL WORK WITH OTHER TRADES AND CONTRACTORS.
 - DETERMINE THE EXACT LOCATION, SIZE, MATERIAL AND ELEVATION OF ALL EXISTING UTILITIES PRIOR TO COMMENCING CONSTRUCTION. PROTECT AND ASSUME RESPONSIBILITY FOR ALL EXISTING UTILITIES WHETHER OR NOT SHOWN ON THIS DRAWING.
 - OBTAIN ALL NECESSARY PERMITS AND APPROVALS FROM THE CITY OF OTTAWA BEFORE COMMENCING CONSTRUCTION.
 - BEFORE COMMENCING CONSTRUCTION OBTAIN AND PROVIDE PROOF OF COMPREHENSIVE ALL RISK AND OPERATIONAL LIABILITY INSURANCE FOR \$5,000,000.00. INSURANCE POLICY TO NAME OWNERS, ENGINEERS AND ARCHITECTS AS CO-INSURED.
 - RESTORE ALL DISTURBED AREAS ON-SITE AND OFF-SITE, INCLUDING TRENCHES AND SURFACES ON PUBLIC ROAD ALLOWANCES TO EXISTING CURBS OR BETTER TO THE SATISFACTION OF THE CITY OF OTTAWA AND ENGINEER.
 - REMOVE FROM SITE ALL EXCESS EXCAVATED MATERIAL, ORGANIC MATERIAL AND DEBRIS UNLESS OTHERWISE INSTRUCTED BY ENGINEER. EXCAVATE AND REMOVE FROM SITE ANY CONTAMINATED MATERIAL. ALL CONTAMINATED MATERIAL SHALL BE DISPOSED OF AT A LICENSED LANDFILL FACILITY.
 - ALL ELEVATIONS ARE GEODETIC.
 - REFER TO GEOTECHNICAL REPORT (No. P0300873) PART 1, DATED MARCH 1, 2024 AND RELIANCE LETTER DATED SEPTEMBER 5, 2024, PREPARED BY GHD, FOR SUBSURFACE CONDITIONS, CONSTRUCTION RECOMMENDATIONS AND GEOTECHNICAL INSPECTION REQUIREMENTS. THE GEOTECHNICAL CONSULTANT IS TO REVIEW ON-SITE CONDITIONS AFTER EXCAVATION PRIOR TO PLACEMENT OF THE GRANULAR MATERIAL.
 - REFER TO ARCHITECTS AND LANDSCAPE ARCHITECTS DRAWINGS FOR BUILDING AND HARD SURFACE AREAS AND DIMENSIONS.
 - REFER TO DEVELOPMENT SERVICES STUDY AND STORMWATER MANAGEMENT REPORT (P.020245) PREPARED BY NOVATECH ENGINEERING CONSULTANTS LTD.
 - SAW CUT AND KEY GRIND ASPHALT AT ALL ROAD CUTS AND ASPHALT TIE IN POINTS AS PER CITY OF OTTAWA STANDARDS (R10).
 - PROVIDE LINE/PARKING PAINTING.

- WATERMAIN NOTES:**
- SUPPLY AND CONSTRUCT ALL WATERMANS AND APPURTENANCES IN ACCORDANCE WITH THE CITY OF OTTAWA STANDARDS AND SPECIFICATIONS - ALL CURRENT VERSIONS AND AS AMENDED:
 - ITEM: WATERMAIN (300mm)
 - ITEM: SANITARY MANHOLE (1200mm)
 - ITEM: VALVE CHAMBER
 - ITEM: VALVE
 - ITEM: HYDRANT INSTALLATION
 - ITEM: THERMAL INSULATION IN SHALLOW TRENCHES
 - ITEM: INSULATION ADJACENT TO OPEN STRUCTURES
 - ITEM: VALVE BOX ASSEMBLY
 - ITEM: WATERMAIN CROSSING BELOW SEWER
 - ITEM: WATERMAIN CROSSING ABOVE SEWER
 - SPECIFICATIONS:
 - ITEM: WATERMAIN
 - ITEM: SANITARY MANHOLE
 - ITEM: VALVE CHAMBER
 - ITEM: VALVE
 - ITEM: HYDRANT INSTALLATION
 - ITEM: THERMAL INSULATION IN SHALLOW TRENCHES
 - ITEM: INSULATION ADJACENT TO OPEN STRUCTURES
 - ITEM: VALVE BOX ASSEMBLY
 - ITEM: WATERMAIN CROSSING BELOW SEWER
 - ITEM: WATERMAIN CROSSING ABOVE SEWER
 - WATERMAIN SHALL BE MINIMUM 24" DEPTH BELOW GRADE, UNLESS OTHERWISE INDICATED.
 - PROVIDE MINIMUM 0.5% CLEARANCE BETWEEN OUTSIDE OF PIPES AT ALL CROSSINGS, UNLESS OTHERWISE INDICATED.
 - WATER SERVICE TO BE CONSTRUCTED TO WITHIN 1.0m OF FOUNDATION WALL AND CAPPED.

- SEWER NOTES:**
- SUPPLY AND CONSTRUCT ALL SEWERS AND APPURTENANCES IN ACCORDANCE WITH THE MOST CURRENT CITY OF OTTAWA STANDARDS AND SPECIFICATIONS - ALL CURRENT VERSIONS AND AS AMENDED:
 - ITEM: STORM/SANITARY MANHOLE (1200mm)
 - ITEM: SANITARY MANHOLE FRAME AND COVER
 - ITEM: STORM/SANITARY MANHOLE FRAME AND COVER
 - ITEM: WATER TIGHT MH FRAME AND COVER
 - ITEM: LANDSCAPE DRAIN (ELBOW, COVER & PIPE)
 - ITEM: SEWER TRENCH
 - ITEM: SHALLOW SEWER
 - ITEM: STORM SEWER
 - ITEM: SANITARY SEWER
 - ITEM: CATCH-BASIN LEAD
 - ITEM: CATCH-BASIN LEAD
 - SPECIFICATIONS:
 - ITEM: STORM/SANITARY MANHOLE (1200mm)
 - ITEM: SANITARY MANHOLE FRAME AND COVER
 - ITEM: STORM/SANITARY MANHOLE FRAME AND COVER
 - ITEM: WATER TIGHT MH FRAME AND COVER
 - ITEM: LANDSCAPE DRAIN (ELBOW, COVER & PIPE)
 - ITEM: SEWER TRENCH
 - ITEM: SHALLOW SEWER
 - ITEM: STORM SEWER
 - ITEM: SANITARY SEWER
 - ITEM: CATCH-BASIN LEAD
 - ITEM: CATCH-BASIN LEAD
 - ALL STORM AND SANITARY SERVICE LATERALS SHALL BE EQUIPPED WITH BACKFLOW PREVENTION DEVICES AS PER THE CITY OF OTTAWA STANDARDS DETAILS S14 AND S14.1 OR S14.2.
 - INSULATE ALL PIPES (SANITARY) THAT HAVE LESS THAN 1.8m COVER WITH HI-40 INSULATION PER CITY OF OTTAWA STANDARD DETAIL S33. PROVIDE 100mm CLEARANCE BETWEEN PIPES AND INSULATION.
 - SEWERS ARE TO BE CONSTRUCTED TO 1.0m FROM FACE OF BUILDING AT A MINIMUM SLOPE OF 1.0%.
 - PIPE BEDDING, COVER AND BACKFILL ARE TO BE COMPACTED TO AT LEAST 90% OF THE STANDARD PROCTOR MAXIMUM DRY DENSITY. THE USE OF CLEAR CRUSHED STONE AS A BEDDING LAYER SHALL NOT BE PERMITTED.
 - FLEXIBLE CONNECTIONS ARE REQUIRED FOR CONNECTING PIPES TO MANHOLES (FOR EXAMPLE KORN-SEAL, POSITIVE SEAL AND DURASEAL). THE CONCRETE GRADE FOR THE PIPE CAN BE ELIMINATED.
 - THE OWNER SHALL REQUIRE THAT THE SITE SERVING CONTRACTOR FIELD TESTS FOR QUALITY CONTROL OF ALL SANITARY SEWERS. LEAKAGE TESTING SHALL BE COMPLETED IN ACCORDANCE WITH OPES 410.07.16, 410.07.16.8 AND 410.07.24. DYE TESTING IS TO BE COMPLETED ON ALL SANITARY SEWERS TO CONFIRM PROPER CONNECTION TO THE SANITARY SEWER MAIN. THE FIELD TESTS SHALL BE REPORTED IN THE PRESENCE OF A CERTIFIED PROFESSIONAL ENGINEER WHO SHALL SUBMIT A CERTIFIED COPY OF THE TEST RESULTS.
 - ALL STORM MANHOLES AND CATCH-BASIN MANHOLES ARE TO HAVE 300mm SLUMPS UNLESS OTHERWISE INDICATED. ALL CATCH-BASINS ARE TO HAVE 600mm SLUMPS.
 - ALL CATCH-BASINS, MANHOLES AND/OR CATCH-BASIN MANHOLES THAT ARE TO HAVE ICDS INSTALLED WITHIN THEM ARE TO HAVE 600mm SLUMPS.
 - ALL WEIRING TIE CONNECTIONS TO BE MADE TO THE PROPOSED STORM SEWER SYSTEM DOWNSTREAM OF ANY INLET CONTROL DEVICES.
 - CONTRACTOR TO TELEVIEW (CCTV) ALL PROPOSED SEWERS, 200mm OR GREATER PRIOR TO BASE COURSE ASPHALT. UPON COMPLETION OF CONTRACT, THE CONTRACTOR IS RESPONSIBLE TO FLUSH AND CLEAN ALL SEWERS & APPURTENANCES.
 - CONTRACTOR TO PROVIDE THE CONSULTANT WITH A GENERAL PLAN OF SERVICES INDICATING ALL SERVING AS-BUILT INFORMATION SHOWN ON THIS PLAN AS BUILT. INFORMATION MUST INCLUDE: PIPE MATERIAL, SIZES, LENGTHS, SLOPES, INVERT AND TIE ELEVATIONS, STRUCTURE LOCATIONS, VALVE AND HYDRANT LOCATIONS, TIE/ELEVATIONS AND ANY ADJUSTMENT CHANGES, ETC.

PROPOSED WATERMAIN TABLE

Station	FIG. ELEVATION	TOP OF WATERMAIN	DESCRIPTION
0+00.00	79.46	77.99	300mm WM TIE CONNECTION TO EX. 600mm WM
0+00.04	79.62	78.44	45° VERTICAL BEND
0+07.17	79.72	78.52	45° VERTICAL BEND
0+05.00	79.78	78.57	45° VERTICAL BEND
0+05.45	79.63	77.31	45° VERTICAL BEND
0+00.70	80.53	78.86	BULK WATER METER IN R4 CHAMBER AT PROPERTY LINE
0+02.01	81.05	78.80	150mm HYDRANT TEE
0+100.78	81.17	79.17	22.5° VERTICAL BEND
0+115.96	81.89	79.55	150mm HYDRANT TEE
0+120.29	81.96	79.59	22.5° VERTICAL BEND
0+153.37	81.98	79.59	22.5° VERTICAL BEND
0+157.40	82.07	79.63	200mm WATER SERVICE TEE
0+158.58	82.17	79.62	VALVE AND VALVE CHAMBER
0+159.75	82.31	79.91	22.5° VERTICAL BEND
0+160.28	82.33	79.88	200mm WATER SERVICE TEE
0+162.40	82.40	79.99	300mm x 250mm REDUCER
0+225.37	82.11	79.71	45° VERTICAL BEND

Station	FIG. ELEVATION	TOP OF WATERMAIN	DESCRIPTION
0+230.04	82.11	79.71	150mm HYDRANT TEE
0+235.53	82.19	79.78	45° VERTICAL BEND
0+309.65	81.93	79.66	150mm HYDRANT TEE
0+326.60	81.93	79.53	45° VERTICAL BEND
0+332.36	81.72	79.32	45° VERTICAL BEND
0+355.68	81.84	79.44	VALVE AND VALVE BOX
0+375.77	81.86	79.46	150mm HYDRANT TEE
0+422.92	81.13	78.73	11.25° VERTICAL BEND
0+428.35	81.91	79.79	11.25° VERTICAL BEND
0+434.66	81.06	78.68	150mm HYDRANT TEE
0+521.12	80.31	77.91	150mm HYDRANT TEE
0+528.86	80.23	77.83	45° VERTICAL BEND
0+528.97	80.14	77.74	45° VERTICAL BEND
0+588.06	80.04	77.64	200mm WATER SERVICE TEE
0+603.40	79.91	76.51	150mm HYDRANT TEE
0+621.40	79.85	76.45	150mm HYDRANT TEE
0+626.40	79.75	76.35	VALVE & VALVE BOX
0+658.40	79.55	76.15	150mm HYDRANT TEE
0+702.40	79.45	76.05	BULK WATER METER IN R4 CHAMBER AT PROPERTY LINE
0+718.40	79.41	76.01	250mm WM TIE CONNECTION TO EX. 600mm WM

CRITICAL SEWER PIPE CROSSING TABLE

CROSSING	LOWER PIPE	HIGHER PIPE	CLEARANCE SURFACE ELEVATION
1	250mm SAN T/P=77.71	300mm STM INV=78.02	+0.25m 79.58 m
2	250mm SAN T/P=77.71	300mm STM INV=79.29	+0.49m 80.50 m
3	250mm SAN T/P=77.41	375mm STM INV=79.73	+0.75m 81.30 m
4	250mm SAN T/P=76.01	300mm STM INV=79.78	+1.77m 81.94 m
5	250mm SAN T/P=77.07	300mm STM INV=81.03	+0.46m 80.13 m
6	250mm SAN T/P=77.01	375mm STM INV=78.10	+0.49m 80.19 m
7	250mm SAN T/P=76.72	375mm STM INV=77.48	+0.55m 79.65 m
8	250mm SAN T/P=76.72	300mm STM INV=77.35	+0.55m 79.92 m
9	250mm SAN T/P=77.02	300mm STM INV=77.47	+0.27m 79.44 m

- BENCHMARK NOTES:**
- IT IS THE RESPONSIBILITY OF THE USER OF THIS INFORMATION TO VERIFY THAT THE JOB BENCHMARK HAS NOT BEEN ALTERED OR DISTURBED AND THAT ITS RELATIVE ELEVATION AND DESCRIPTION AGREES WITH THE INFORMATION SHOWN ON THE DRAWING.
 - BENCHMARKS WERE PROVIDED ON THE TOPOGRAPHIC PLAN OF SURVEY OF BLOCK 6 AND PART OF BLOCK 1, REGISTERED PLAN 4M-442 AND PART OF LOTS 8 AND 9 CONVESSION 4. GEOGRAPHIC TOWNSHIP OF MARCH, CITY OF OTTAWA, SURVEYED BY ANNS, OUSLOVIAN AND VOLBERG LTD. SIGNED AND DATED FEBRUARY 26, 2002.
 - BENCHMARKS WERE PROVIDED ON THE TOPOGRAPHIC PLAN OF SURVEY OF BLOCK 6 AND PART OF BLOCK 1, REGISTERED PLAN 4M-442 AND PART OF LOTS 8 AND 9 CONVESSION 4. GEOGRAPHIC TOWNSHIP OF MARCH, CITY OF OTTAWA, SURVEYED BY ANNS, OUSLOVIAN AND VOLBERG LTD. SIGNED AND DATED FEBRUARY 26, 2002.

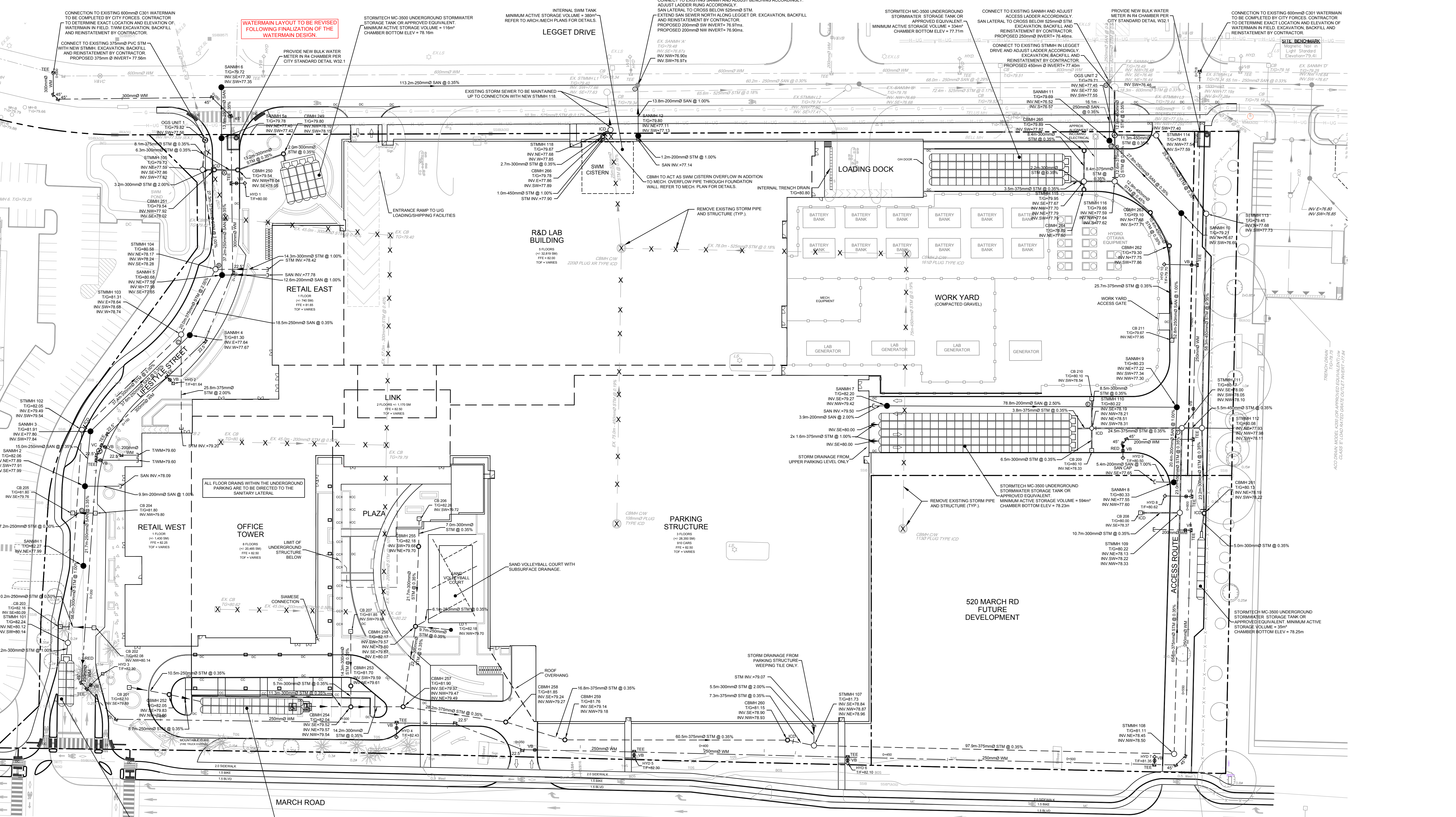

REFER TO ROADWAY MODIFICATIONS PLANS (RMA - BY OTHERS) FOR PROPOSED RMA WORKS WITHIN THE MARCH ROAD RIGHT-OF-WAY AND THE NEW SITE ACCESS ENTRIES.

STORMTECH MC-3500 UNDERGROUND STORMWATER STORAGE TANK MINIMUM ACTIVE STORAGE VOLUME = 50m³ CHAMBER BOTTOM ELEV = 80.17m

STORMTECH MC-3500 UNDERGROUND STORMWATER STORAGE TANK MINIMUM ACTIVE STORAGE VOLUME = 120m³ CHAMBER BOTTOM ELEV = 79.95m

STORMTECH MC-3500 UNDERGROUND STORMWATER STORAGE TANK MINIMUM ACTIVE STORAGE VOLUME = 30m³ CHAMBER BOTTOM ELEV = 78.25m

NOKIA Ottawa Campus
 570 March Rd, Kanata/Ottawa ON K2K 2T6

Gensler
 5505 Greenville Ave Dallas TX 75206
 Tel 214.273.1500

Supervisor: Arvin D'Silva
 Planner: Victoria Liu
 Civil Engineering: Gensler
 Architectural Site Planning: Gensler
 Mechanical Engineering: Gensler
 Structural Engineering: Gensler
 Electrical Engineering: Gensler
 Sanitary and Industrial: Gensler
 Geotechnical Engineering: Gensler

Date	Description
SEP 12/24	ISSUED FOR SITE PLAN CONTROL APPROVAL
NOV 15/24	REVISED PER CITY COMMENTS

NOVATECH
 Engineers, Planners & Landscape Architects
 Suite 200, 140 Michael Cowan Drive
 Ottawa, Ontario, Canada K2M 1R6
 Telephone: (613) 254-9642
 Facsimile: (613) 254-5867
 Website: www.novatech-eng.com



NOT FOR CONSTRUCTION

Project Name: **Nokia Ottawa Campus**
 Project Number: **027.7946.000**
 Description: **GENERAL PLAN OF SERVICES**

Scale: _____

C100
 City Project no. P-2023-0229
 © 2021 Gensler

LEGEND

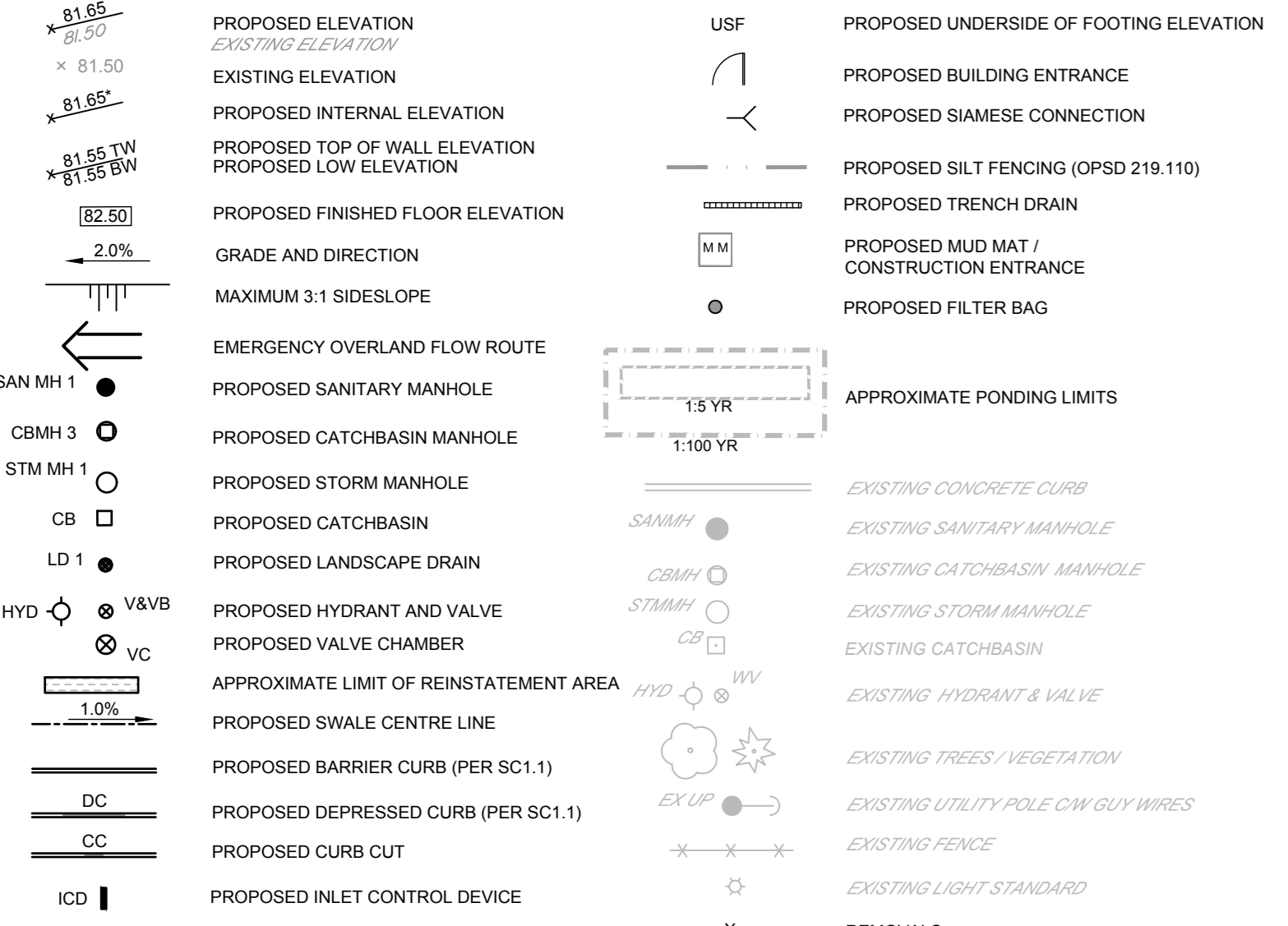

GENERAL NOTES

- 1. COORDINATE AND SCHEDULE ALL WORK WITH OTHER TRADES AND CONTRACTORS.
2. DETERMINE THE EXACT LOCATION, SIZE, MATERIAL, AND ELEVATION OF ALL EXISTING UTILITIES PRIOR TO COMMENCING CONSTRUCTION...

GRADING NOTES

- 1. ALL TOPSOIL, ORGANIC OR DELETERIOUS MATERIAL MUST BE ENTIRELY REMOVED FROM BENEATH THE PROPOSED PAVED AREAS AS DIRECTED BY THE SITE ENGINEER OR GEOTECHNICAL ENGINEER.
2. EXPOSED SUBGRADE IN PROPOSED PAVED AREAS SHOULD BE PROOF ROLLED WITH A LARGE STEEL DRUM ROLLER AND INSPECTED BY THE GEOTECHNICAL ENGINEER PRIOR TO THE PLACEMENT OF GRANULARS...

EROSION AND SEDIMENT CONTROL NOTES

- 1. THE CONTRACTOR SHALL IMPLEMENT BEST MANAGEMENT PRACTICES TO PROVIDE FOR PROTECTION OF THE AREA DRAINAGE SYSTEM AND THE RECEIVING WATERCOURSE DURING CONSTRUCTION ACTIVITIES.
2. ALL EROSION AND SEDIMENT CONTROLS ARE TO BE INSTALLED TO THE SATISFACTION OF THE ENGINEER AND THE CITY OF OTTAWA. THEY ARE TO BE APPROPRIATE TO THE SITE CONDITIONS PRIOR TO UNDERTAKING ANY SITE ALTERATION INCLUDING GRADING, REMOVAL OF VEGETATION, ETC. AND DURING ALL PHASES OF SITE PREPARATION AND CONSTRUCTION...

BENCHMARK NOTES

- 1. ELEVATIONS SHOWN ARE GEODETIC AND ARE REFERRED TO THE CDVD82 GEODETIC DATUM.
2. IT IS THE RESPONSIBILITY OF THE USER OF THIS INFORMATION TO VERIFY THAT THE JOB BENCHMARK HAS NOT BEEN ALTERED OR DISTURBED AND THAT ITS RELATIVE ELEVATION AND DESCRIPTION AGREES WITH THE INFORMATION ON THIS DRAWING.

LEGGT DRIVE REINSTATEMENT

- 1. RESTORE ALL DISTURBED R.O.W. AREAS TO EXISTING CONDITIONS OR BETTER TO THE SATISFACTION OF MUNICIPAL AUTHORITIES. ASPHALT TO MEET PG 56-34 TRAFFIC LEVEL B STANDARDS FOR MINOR COLLECTOR ROADS AS PER CITY SPECIFICATION F-3106.
2. REINSTATE ALL DISTURBED ROADWAY AREAS AND SAW CUTS BY REGRADING ASPHALT AT ALL ROAD CUTS / ASPHALT TIE IN POINTS AS PER CITY OF OTTAWA STANDARD R10.

PAVEMENT STRUCTURES

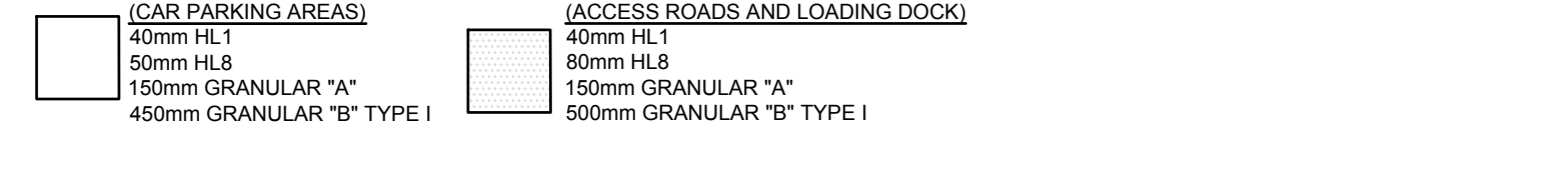
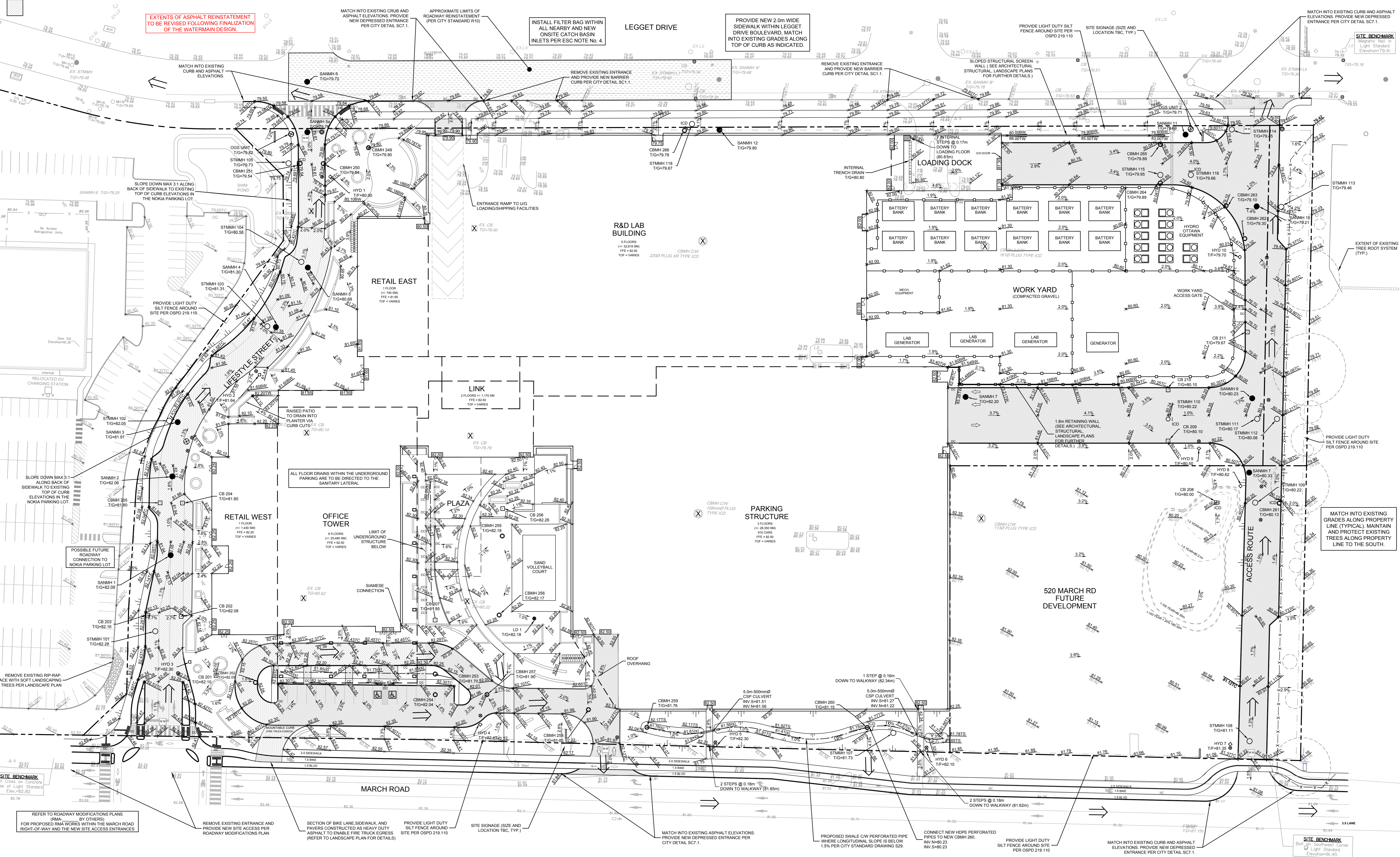

Table with 4 columns: ESC Measure, Symbol, Description, and Responsibility. Lists various erosion and sediment control measures like silt fences, sediment basins, etc.



NOKIA Ottawa Campus
570 March Rd, Kanata Ottawa ON K2K 2T6

Gensler

5005 Greenville Ave Dallas TX 75206
Tel 214.273.1500
Project Manager: Vikraman Liso
Civil Engineering: Novatech
Architectural Site Planning: Novatech
Civil Engineering: Novatech
Mechanical Engineering: Novatech

Table with 2 columns: Date and Description. Shows approval dates for site plan control approval and revised comments.

NOVATECH
Engineers, Planners & Landscape Architects
Suite 200, 140 Michael Cowpland Drive
Ottawa, Ontario, Canada K2M 1P6

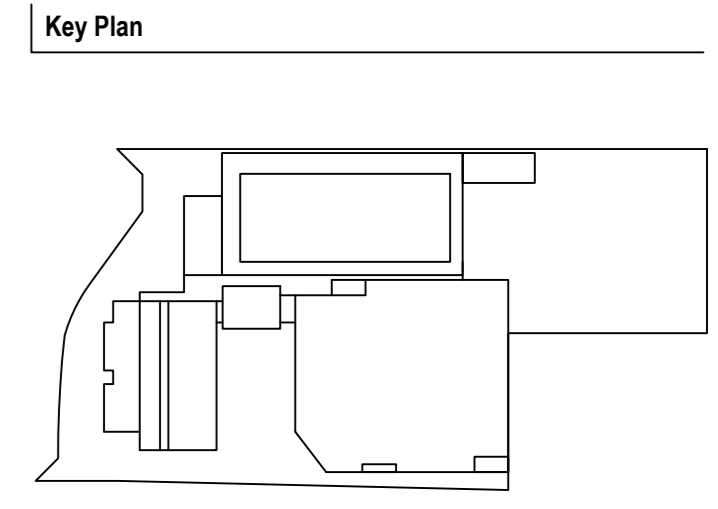

NOT FOR CONSTRUCTION

Project Name: Nokia Ottawa Campus
Project Number: 027.7946.000
Description: GRADING AND EROSION AND SEDIMENT CONTROL PLAN
Scale: 1:400

C200
© 2021 Gensler

LEGEND

- DRAINAGE AREA LIMITS
- PRE-DEVELOPMENT AREA ID
- PRE-DEVELOPMENT DRAINAGE AREA (PA)
- 1.5 YEAR WEIGHTED RUNOFF COEFFICIENT
- EXISTING CONCRETE CURB
- EXISTING VALVE & VALVE BOX
- EXISTING SERVICE POST
- EXISTING HYDRANT
- EXISTING CATCHBASIN
- EXISTING CATCHBASIN
- EXISTING UTILITY POLE
- EXISTING UTILITY POLE
- EXISTING UTILITY POLE
- EXISTING UTILITY POLE
- EXISTING DRAINAGE DIRECTION ARROWS
- EXISTING OVERLAND FLOW

GENERAL NOTES:

- COORDINATE AND SCHEDULE ALL WORK WITH OTHER TRADES AND CONTRACTORS.
- DETERMINE THE EXACT LOCATION, SIZE, MATERIAL AND ELEVATION OF ALL EXISTING UTILITIES PRIOR TO COMMENCING CONSTRUCTION. PROTECT AND ASSUME RESPONSIBILITY FOR ALL EXISTING UTILITIES WHETHER OR NOT SHOWN ON THIS DRAWING.
- OBTAIN ALL NECESSARY PERMITS AND APPROVALS FROM THE CITY OF OTTAWA BEFORE COMMENCING CONSTRUCTION.
- BEFORE COMMENCING CONSTRUCTION OBTAIN AND PROVIDE PROOF OF COMPREHENSIVE, ALL RISK OPERATIONAL LIABILITY INSURANCE FOR \$5,000,000.00. INSURANCE POLICY TO NAME OWNERS, ENGINEERS AND ARCHITECTS AS CO-INSURED.
- COMPLETE ALL WORKS IN ACCORDANCE WITH THE MOST CURRENT CITY OF OTTAWA STANDARDS AND SPECIFICATIONS USING THE CURRENT GUIDELINES, BYLAWS AND STANDARDS INCLUDING MATERIALS OF CONSTRUCTION, DIMENSION AND ALL RELEVANT REFERENCES TO OPIS, CPSS & HWMA GUIDELINES - ALL CURRENT VERSIONS AND AS AMENDED.
- RESTORE ALL DISTURBED AREAS ON-SITE AND OFF-SITE, INCLUDING TRENCHES AND SURFACES ON PUBLIC ROAD ALLOWANCES TO EXISTING CONDITIONS OR BETTER TO THE SATISFACTION OF THE CITY OF OTTAWA AND ENGINEER.
- REMOVE FROM SITE ALL EXCESS EXCAVATED MATERIAL, ORGANIC MATERIAL AND DEBRIS UNLESS OTHERWISE INSTRUCTED BY ENGINEER. EXCAVATE AND REMOVE FROM SITE ANY CONTAMINATED MATERIAL. ALL CONTAMINATED MATERIAL SHALL BE DISPOSED OF AT A LICENSED LANDFILL FACILITY.
- ALL ELEVATIONS ARE GEODETIC.
- REFER TO GEOTECHNICAL REPORT NO: P10386873-RPT-1, DATED MARCH 6, 2024 AND RELIANCE LETTER (DATED SEPTEMBER 5, 2024), PREPARED BY GHQ, FOR SUBSURFACE CONDITIONS, CONSTRUCTION RECOMMENDATIONS, AND GEOTECHNICAL INSPECTION REQUIREMENTS. THE GEOTECHNICAL CONSULTANT IS TO REVIEW ON-SITE CONDITIONS AFTER EXCAVATION PRIOR TO PLACEMENT OF THE GRANULAR MATERIAL.
- REFER TO ARCHITECT'S AND LANDSCAPE ARCHITECT'S DRAWINGS FOR BUILDING AND HARDSURFACE AREAS AND DIMENSIONS.
- REFER TO THE DEVELOPMENT SERVICES STUDY AND STORMWATER MANAGEMENT REPORT (R-2023-082) PREPARED BY NOVATECH.
- SAW CUT AND KEY GRIND ASPHALT AT ALL ROAD CUTS AND ASPHALT TIE IN POINTS AS PER CITY OF OTTAWA STANDARDS (R10).
- PROVIDE LINE PARKING PAINTING.

BENCHMARK NOTES:

- ELEVATIONS SHOWN ARE GEODETIC AND ARE REFERRED TO THE CGVD28 GEODETIC DATUM.
- IT IS THE RESPONSIBILITY OF THE USER OF THIS INFORMATION TO VERIFY THAT THE JOB BENCHMARK HAS NOT BEEN ALTERED OR DISTURBED AND THAT ITS RELATIVE ELEVATION AND DESCRIPTION AGREES WITH THE INFORMATION SHOWN ON THIS DRAWING.
- BENCHMARKS WERE PROVIDED ON THE TOPOGRAPHIC PLAN OF SURVEY OF BLOCK 6 AND PART OF BLOCK 1 REGISTERED PLAN 8M-62 AND PART OF LOTS 1 AND 2 CONCESSION 4, GEOGRAPHIC TOWNSHIP OF MARCH, CITY OF OTTAWA, SURVEYED BY ANNE, O'SULLIVAN AND VOLEBEK LTD, SIGNED AND DATED FEBRUARY 20, 2022.

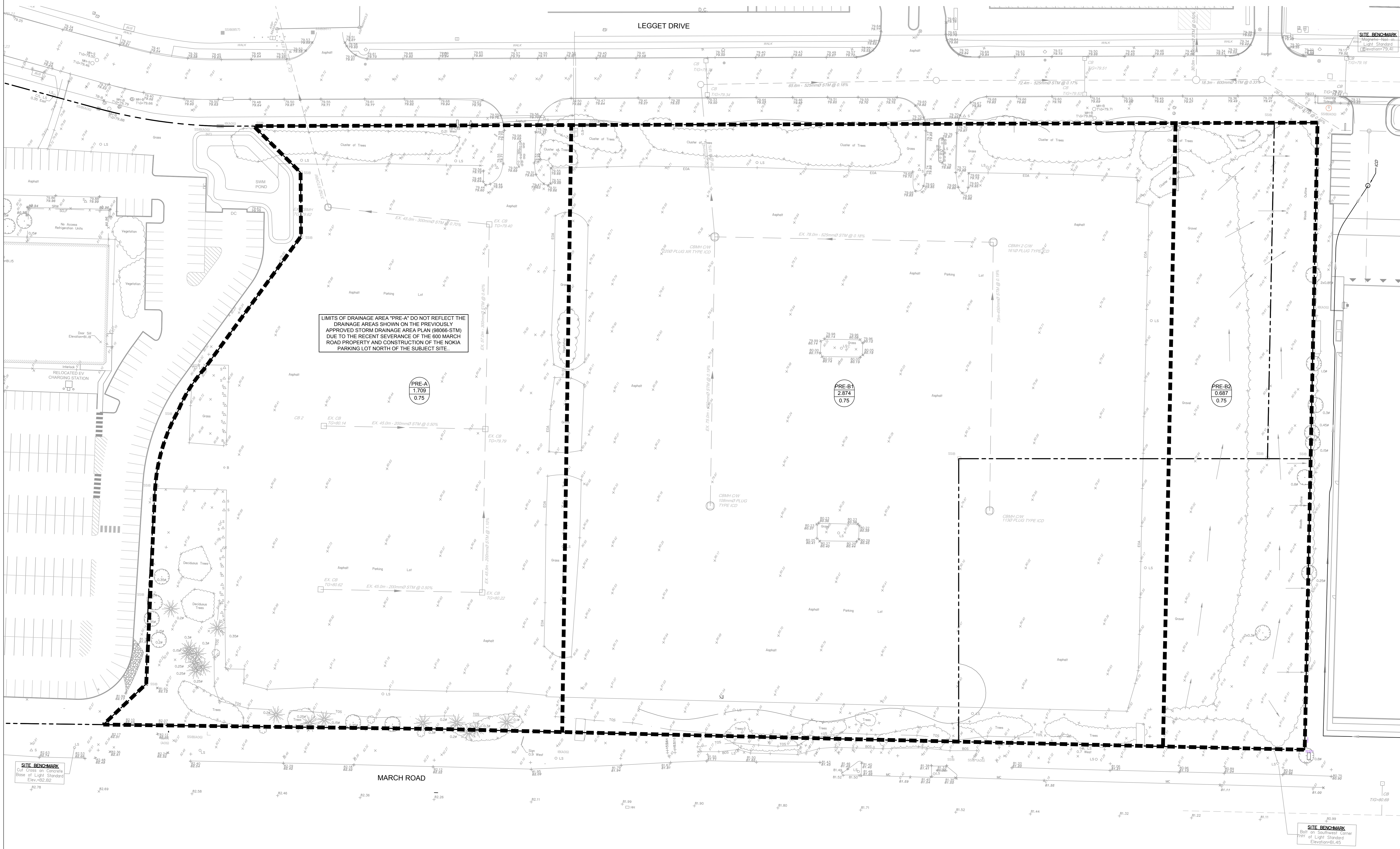

NOKIA Ottawa Campus
 570 March Rd, Kanata Ottawa ON K2K 2T6

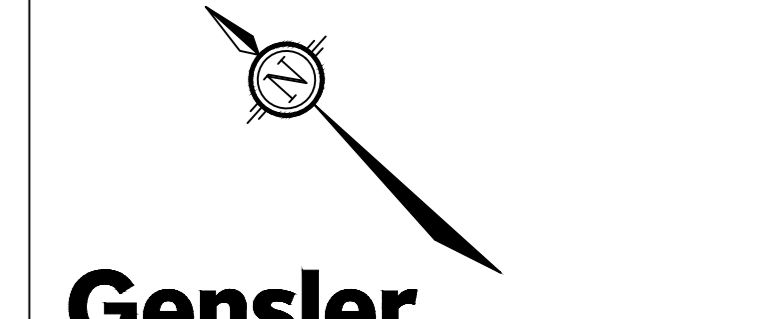

Gensler
 5005 Greenville Ave, Dallas TX 75206
 Tel: 214.273.1500
 Surveyor: Anne O'Sullivan, Volobek Ltd
 Planning Consultant: O. Waters@gensler.com
 Civil Engineering: M. Waters@gensler.com
 Novatech: F. Hueston@novatech-eng.com
 Architectural Site Planning: Gensler: Barry.Hughes@gensler.com
 Mechanical Engineering: Smith and Anderson: Andre.douglas@smithandanderson.com
 Mechanical Engineering Study: Smith and Anderson: Elaine.guerrero@smithandanderson.com
 Geotechnical Engineering: GHQ: Karl.robertson@ghq.com
 Landscape Planning: GHQ: Gensler@gensler.com
 Structural Engineering: AAS: jstewart@aas.ca
 Noise Report: Gensler: jstewart@aas.ca
 Gradient/Travel: J. Foster@gradstair.com
 Transportation Planners: Starlec: Argo.feron@starlec.com

Date	Description
NOV 15/24	ISSUED FOR SITE PLAN CONTROL APPROVAL

NOVATECH
 Engineers, Planners & Landscape Architects
 Suite 200, 240 Michael Compton Drive
 Ottawa, Ontario, Canada K2M 1P6
 Telephone: (613) 254-9643
 Facsimile: (613) 254-9887
 Website: www.novatech-eng.com

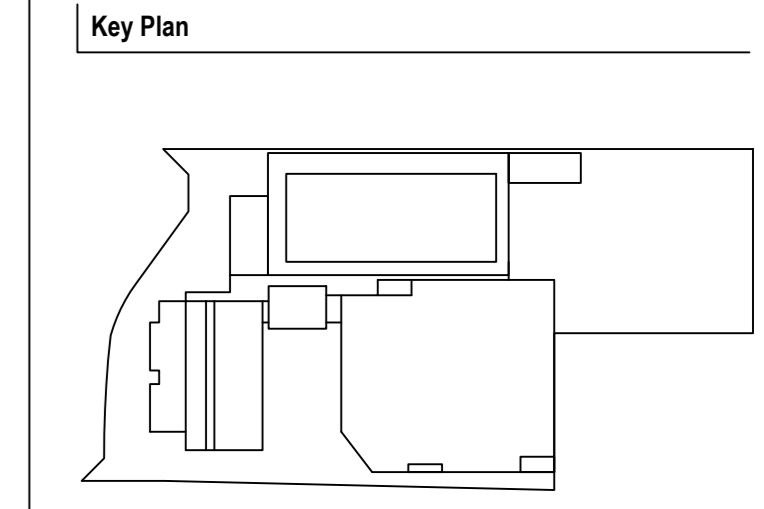

Seal / Signature

NOT FOR CONSTRUCTION

Project Name
Nokia Ottawa Campus

Project Number
027.7946.000

Description
PRE-DEVELOPMENT STORM DRAINAGE PLAN

Scale
 1 : 400

C300

LEGEND

	PROPOSED BARRIER CURB
	PROPOSED DEPRESSED CURB
	PROPOSED CURB CUT
	DRAINAGE AREA LIMITS
	POST-DEVELOPMENT AREA ID
	POST-DEVELOPMENT DRAINAGE AREA (A)
	1.5 YEAR WEIGHTED RUNOFF COEFFICIENT
	PROPOSED STORM MANHOLE
	PROPOSED CATCHBASIN MANHOLE
	PROPOSED CATCHBASIN
	CONTROLLED FLOW ROOF DRAIN
	PROPOSED LANDSCAPE DRAIN
	PROPOSED STORM SEWER AND FLOW DIRECTION
	PROPOSED INLET CONTROL DEVICE
	EMERGENCY OVERLAND FLOW ROUTE
	PROPOSED TRENCH DRAIN

- GENERAL NOTES:**
- COORDINATE AND SCHEDULE ALL WORK WITH OTHER TRADES AND CONTRACTORS.
 - DETERMINE THE EXACT LOCATION, SIZE, MATERIAL AND ELEVATION OF ALL EXISTING UTILITIES PRIOR TO COMMENCING CONSTRUCTION. PROTECT AND ASSUME RESPONSIBILITY FOR ALL EXISTING UTILITIES WHETHER OR NOT SHOWN ON THIS DRAWING.
 - OBTAIN ALL NECESSARY PERMITS AND APPROVALS FROM THE CITY OF OTTAWA BEFORE COMMENCING CONSTRUCTION.
 - BEFORE COMMENCING CONSTRUCTION OBTAIN AND PROVIDE PROOF OF COMPREHENSIVE, ALL RISK AND OPERATIONAL LIABILITY INSURANCE FOR \$1,000,000.00. INSURANCE POLICY TO NAME OWNERS, ENGINEERS AND ARCHITECTS AS CO-INSURED.
 - COMPLETE ALL WORKS IN ACCORDANCE WITH THE MOST CURRENT CITY OF OTTAWA STANDARDS AND SPECIFICATIONS USING THE CURRENT GUIDELINES, BYLAWS AND STANDARDS INCLUDING MATERIALS OF CONSTRUCTION, DIMENSION AND ALL RELEVANT REFERENCES TO OPSIS, OPSD, AWWA GUIDELINES - ALL CURRENT VERSIONS AND 'AS AMENDED'.
 - RESTORE ALL DISTURBED AREAS ON-SITE AND OFF-SITE, INCLUDING TRENCHES AND SURFACES ON PUBLIC ROAD ALLOWANCES TO EXISTING CONDITIONS OR BETTER TO THE SATISFACTION OF THE CITY OF OTTAWA AND ENGINEER.
 - REMOVE FROM SITE ALL EXCESS EXCAVATED MATERIAL, ORGANIC MATERIAL AND DEBRIS UNLESS OTHERWISE INSTRUCTED BY ENGINEER. EXCAVATE AND REMOVE FROM SITE ANY CONTAMINATED MATERIAL. ALL CONTAMINATED MATERIAL SHALL BE DISPOSED OF AT A LICENSED LANDFILL FACILITY.
 - ALL ELEVATIONS ARE GEODETIC.
 - REFER TO GEOTECHNICAL REPORT (NO. PG-2008873-RPT-1, DATED MARCH 6, 2024) AND RELIANCE LETTER (DATED SEPTEMBER 5, 2024), PREPARED BY GHD, FOR SUBSURFACE CONDITIONS, CONSTRUCTION RECOMMENDATIONS AND GEOTECHNICAL INSPECTION REQUIREMENTS. THE GEOTECHNICAL CONSULTANT IS TO REVIEW ON-SITE CONDITIONS AFTER EXCAVATION PRIOR TO PLACEMENT OF THE GRANULAR MATERIAL.
 - REFER TO ARCHITECT'S AND LANDSCAPE ARCHITECT'S DRAWINGS FOR BUILDING AND HARDSURFACE AREAS AND DIMENSIONS.
 - REFER TO THE DEVELOPMENT SERVICES STUDY AND STORMWATER MANAGEMENT REPORT (R-2023-062) PREPARED BY NOVATECH.
 - SAW CUT AND KEY GRIND ASPHALT AT ALL ROAD CUTS AND ASPHALT TIE IN POINTS AS PER CITY OF OTTAWA STANDARDS (S-101).
 - PROVIDE LINE PARKING PAINTING.

- BENCHMARK NOTES:**
- ELEVATIONS SHOWN ARE GEODETIC AND ARE REFERRED TO THE COV028 GEODETIC DATUM.
 - IT IS THE RESPONSIBILITY OF THE USER OF THIS INFORMATION TO VERIFY THAT THE JOB BENCHMARK HAS NOT BEEN ALTERED OR DISTURBED AND THAT ITS RELATIVE ELEVATION AND DESCRIPTION AGREES WITH THE INFORMATION SHOWN ON THIS DRAWING.
 - BENCHMARKS WERE PROVIDED ON THE TOPOGRAPHIC PLAN OF SURVEY OF BLOCK AND PART OF BLOCK 1 REGISTERED PLAN 40442 AND PART OF LOTS 8 AND 9 AND CONVESSION 4, GEOGRAPHIC TOWNSHIP OF MARCH, CITY OF OTTAWA, SURVEYED BY ANNIS, O'SULLIVAN AND VOLEBEK LTD.

INLET CONTROL DEVICE DATA TABLE: AREA A-1									
DESIGN EVENT	ICD TYPE (PLUG TYPE)	OUTLET STRUCTURE	DIAMETER OF OUTLET PIPE (mm)	PEAK DESIGN FLOW (L/s)	DESIGN HEAD (m)	WATER ELEVATION (m)	VOLUME (m³)	AVAILABLE STORAGE	
T3 1YR	PEX TEMPEST HP TYPE 8	STMMH 102	300mm P/C	27.5	0.28	78.20	18.4	-400 m³	
T3 1YR	PEX TEMPEST HP TYPE 8	STMMH 102	300mm P/C	27.5	0.28	78.20	18.4	-400 m³	

ROOF DRAIN TABLE									
AREA ID	BUILDING	ROOF DRAIN (MATERIALS)	ROOF DRAIN OPENING SETTING	2 YEAR RELEASE RATE	APPROX 2 YR PONDING DEPTH	5 YEAR RELEASE RATE	APPROX 5 YEAR PONDING DEPTH	100 YEAR RELEASE RATE	APPROX 100 YR PONDING DEPTH
A-3	RETAIL WEST	RD 1 (RD-100-A-ADJ)	CLOSED	0.95 L/s	8 cm	1.26 L/s	10 cm	1.89 L/s	15 cm
		RD 2 (RD-100-A-ADJ)	FULLY EXPOSED	0.95 L/s	8 cm	1.26 L/s	10 cm	1.89 L/s	15 cm
		RD 3 (RD-100-A-ADJ)	FULLY EXPOSED	0.95 L/s	8 cm	1.26 L/s	10 cm	1.89 L/s	15 cm
		RD 4 (RD-100-A-ADJ)	FULLY EXPOSED	0.95 L/s	8 cm	1.26 L/s	10 cm	1.89 L/s	15 cm
A-5	OFFICE TOWER	RD 5 (RD-100-A-ADJ)	CLOSED	0.95 L/s	8 cm	1.26 L/s	10 cm	1.89 L/s	15 cm
		RD 6 (RD-100-A-ADJ)	CLOSED	0.95 L/s	8 cm	1.26 L/s	10 cm	1.89 L/s	15 cm
		RD 7 (RD-100-A-ADJ)	CLOSED	0.95 L/s	8 cm	1.26 L/s	10 cm	1.89 L/s	15 cm
		RD 8 (RD-100-A-ADJ)	CLOSED	0.95 L/s	8 cm	1.26 L/s	10 cm </tr		

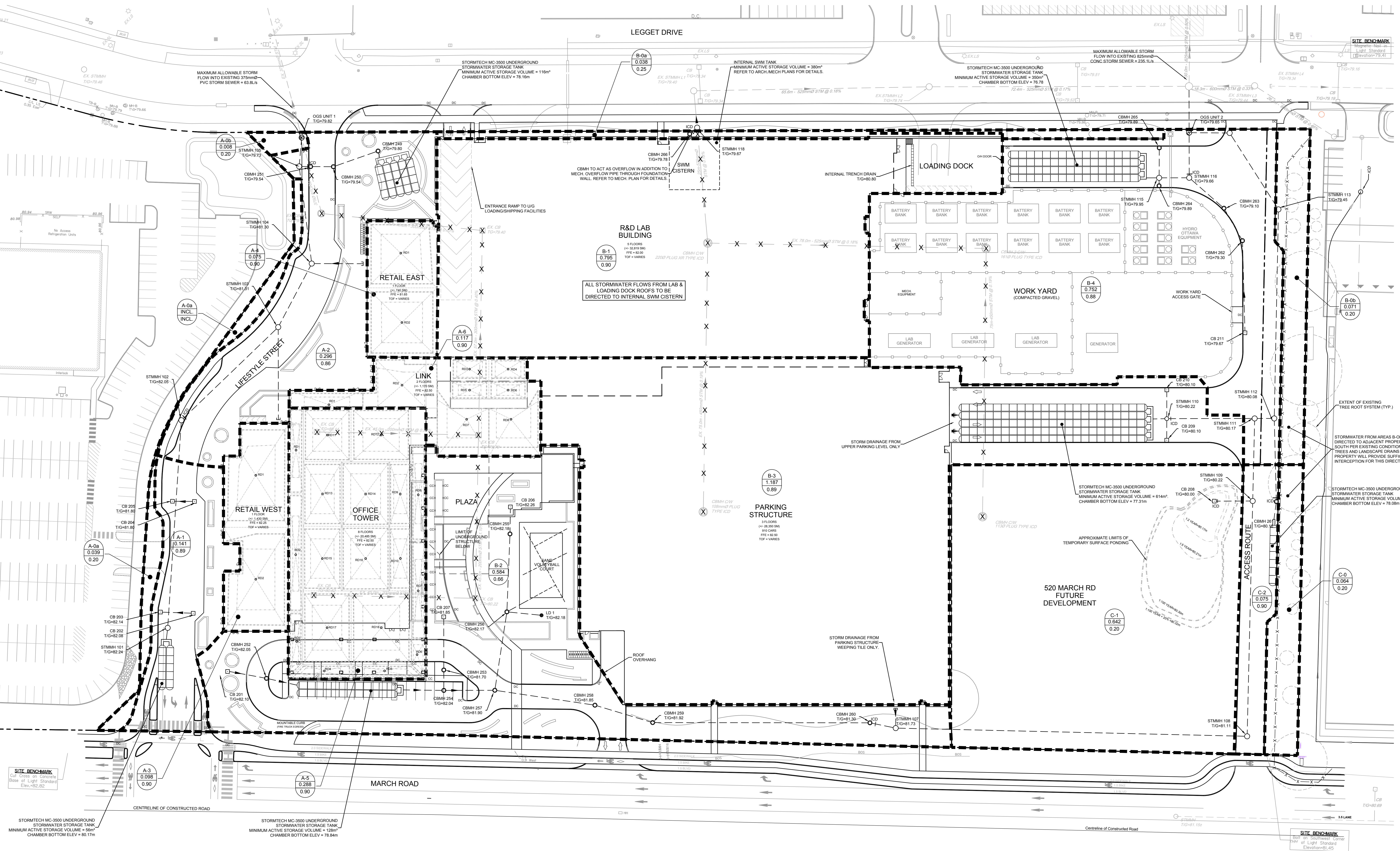

NOKIA Ottawa Campus
570 March Rd, Kanata/Ottawa ON K2K 2T6

GenSLER
5505 Greenville Ave Dallas TX 75206
Tel 214.273.1500

5005 Greenville Ave
Dallas TX 75206
Tel 214.273.1500

Project: 214-273-1500
City: Dallas, TX
Country: USA
Website: www.gensler.com

Date	Description
SEP 12/24	ISSUED FOR SITE PLAN CONTROL APPROVAL
NOV 15/24	REVISED PER CITY COMMENTS

NOVATECH
Engineers, Planners & Landscape Architects
Suite 200, 140 Michael Cowpland Drive
Ottawa, Ontario, Canada K2M 1R6
Telephone: (613) 254-9642
Facsimile: (613) 254-5667
Website: www.novatech.com

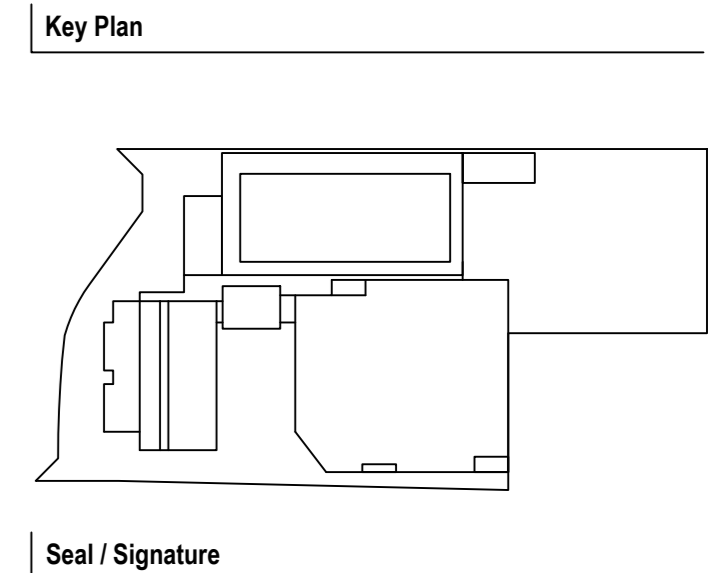

NOT FOR CONSTRUCTION

Project Name
Nokia Ottawa Campus

Project Number
027.7946.000

Description
POST-DEVELOPMENT STORMWATER MANAGEMENT PLAN

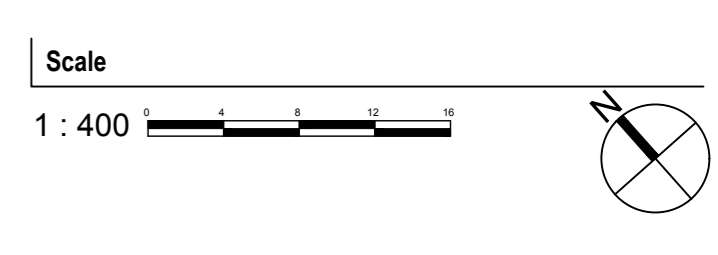

City Project no. P-C2023-0229



5005 Greenville Ave Dallas TX 75206 Tel: 214.273.1500
 Surveyor: Arnie O'Sullivan, Victoria Ltd
 Planning Consultant: Novatech
 Civil Engineering: Novatech
 Architectural Site Planning: Novatech
 Geotechnical Engineering: Smith and Anderson
 Mechanical Engineering: Smith and Anderson
 Structural Engineering: Smith and Anderson
 Landscape Planning: Gensler
 Civil: Gensler
 Noise Report: Gensler
 Transportation Planners: Gensler
 Starline: Argento

Date	Description
NOV 15/24	ISSUED FOR SITE PLAN CONTROL APPROVAL

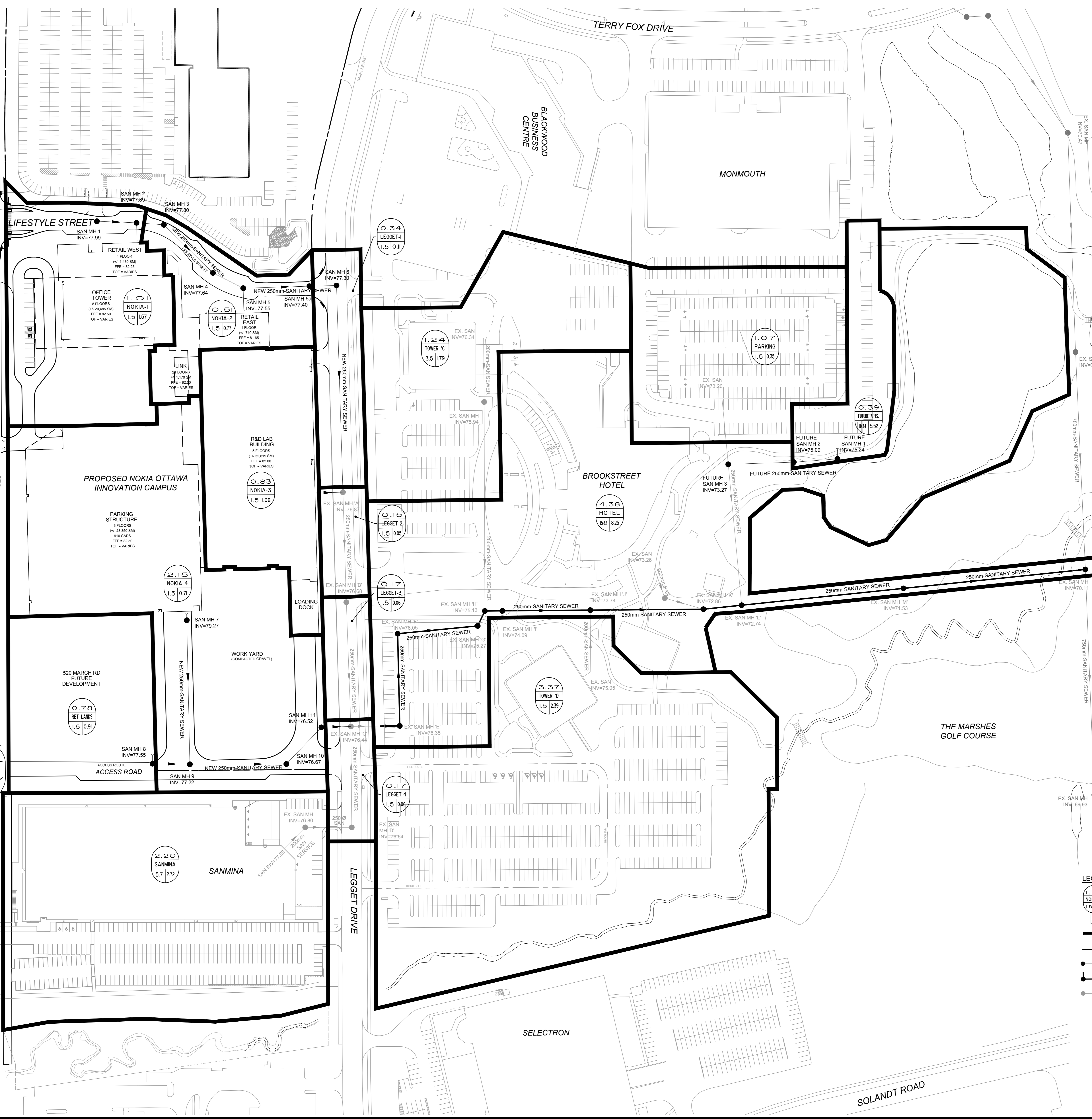

LEGEND

- AREA IN HECTARES
- AREA IDENTIFIER
- PEAK FLOW RATE (L/S) incl. Extraneous Flows
*Refer to Sanitary and Storm Sewer Design Brief for detailed calculations of flow rates for each development
- PEAKING FACTOR
- SANITARY DRAINAGE AREA BOUNDARY
- DIRECTION OF FLOW
- PROPOSED TRIBUTARY SANITARY SEWER AND MH
- EXISTING SANITARY SEWER AND MH ON KRP LANDS
- EXISTING TRIBUTARY SANITARY SEWER AND MH

NOVATECH
 Engineers, Planners & Landscape Architects
 Suite 200, 240 Michael Coopers Drive
 Ottawa, Ontario, Canada K2M 1P6
 Telephone: (613) 254-9643
 Facsimile: (613) 254-5827
 Website: www.novatech-eng.com

Key Plan

Seal / Signature

NOT FOR CONSTRUCTION

Project Name
Nokia Ottawa Campus

Project Number
027.7946.000

Description
SANITARY DRAINAGE AREA PLAN

Scale
1 : 750

C400

City Project no: PC2023-0229

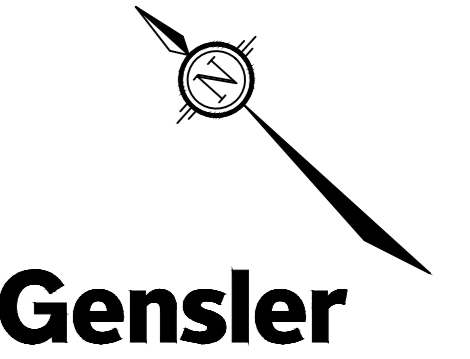

5005 Greenville Ave
Dallas TX 75206
Tel: 214.273.1500
Surveor: Anita O'Sullivan, Victoria Ltd
Planning Consultant
Novatech: C.Waters@novatech-eng.com
Architectural Site Planning: Novatech: F.Pascoe@novatech-eng.com
Civil Engineering: Gensler: Barry.Sha@gensler.com
Mechanical Engineering: Smith and Anderson: Andre.douac@smithandanderson.com
Mechanical Engineering: Smith and Anderson: Elaine.guerrero@smithandanderson.com
Geotechnical Engineering: GSD: Karl.roberts@gtd.com
Landscape Planning: Gensler: Gensler@ca.ca
Structural Engineering: ASB: Jannan@asb.ca
Noise Report: Graham Wood: Joshua.Hosler@gradentier.com
Transportation Planners: Starlec: Argo.veron@starlec.com

Date	Description
NOV 15/24	ISSUED FOR SITE PLAN CONTROL APPROVAL

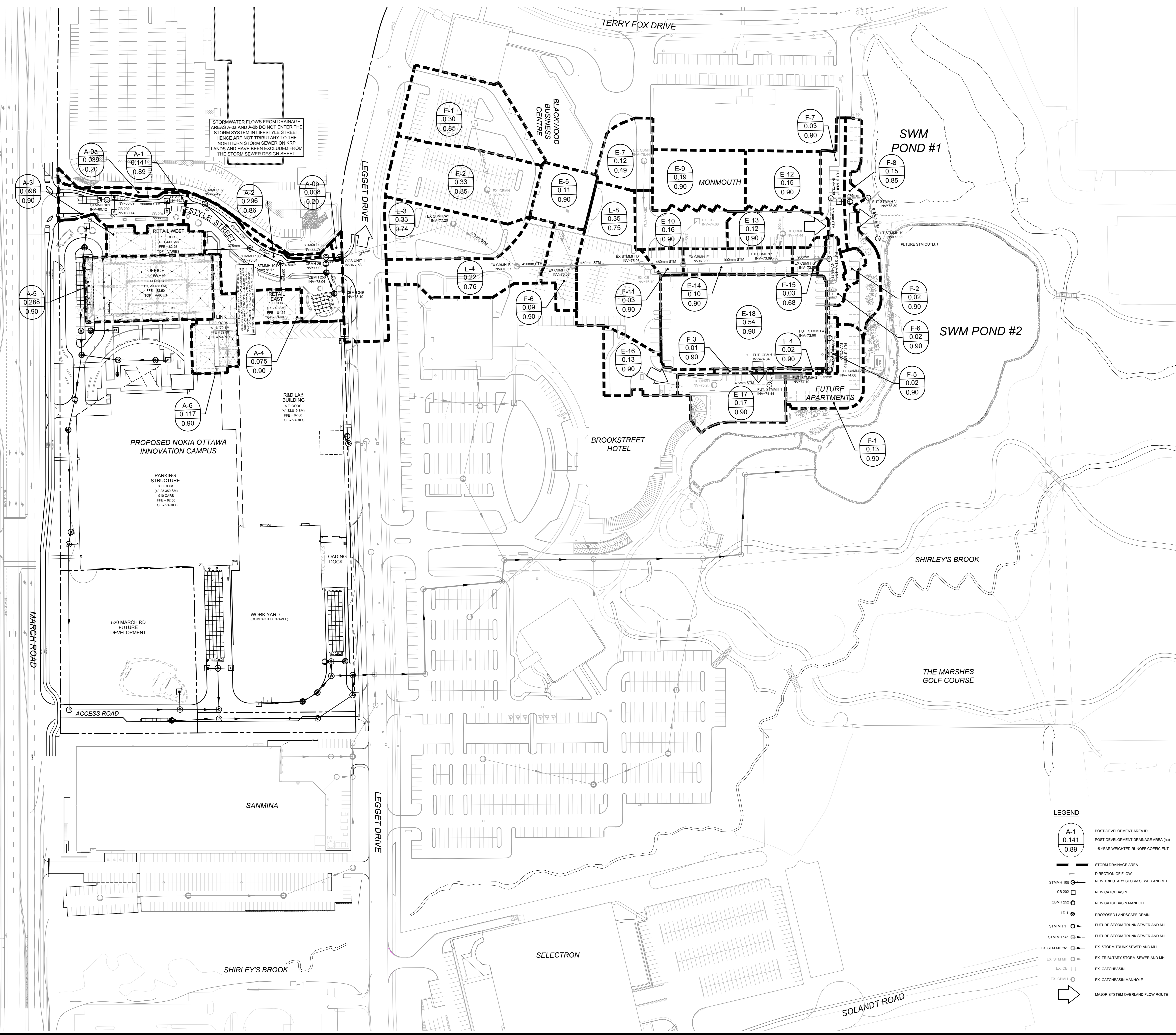

STORMWATER FLOWS FROM DRAINAGE AREAS A-0a AND A-0b DO NOT ENTER THE STORM SYSTEM IN LIFESTYLE STREET. HENCE ARE NOT TRIBUTARY TO THE NORTHERN STORM SEWER ON KRP LANDS AND HAVE BEEN EXCLUDED FROM THE STORM SEWER DESIGN SHEET.

RETAIL WEST
3 FLOORS
(+/- 20,485 SM)
FFE = 82.25
TOP = VARIES

OFFICE TOWER
8 FLOORS
(+/- 40,970 SM)
FFE = 82.25
TOP = VARIES

LINK
12 FLOORS
(+/- 4,170 SM)
FFE = 82.25
TOP = VARIES

RETAIL EAST
1 FLOOR
(+/- 140 SM)
FFE = 81.95
TOP = VARIES

R&D LAB BUILDING
5 FLOORS
(+/- 26,819 SM)
FFE = 82.00
TOP = VARIES

PARKING STRUCTURE
3 FLOORS
(+/- 28,350 SM)
910 CARS
FFE = 82.00
TOP = VARIES

LEGEND

	POST-DEVELOPMENT AREA ID POST-DEVELOPMENT DRAINAGE AREA (m ²) 15 YEAR WEIGHTED RUNOFF COEFFICIENT
	STORM DRAINAGE AREA
	DIRECTION OF FLOW
	NEW TRIBUTARY STORM SEWER AND MH
	NEW CATCHBASIN
	NEW CATCHBASIN MANHOLE
	PROPOSED LANDSCAPE DRAIN
	FUTURE STORM TRUNK SEWER AND MH
	FUTURE STORM TRUNK SEWER AND MH
	EX. STORM TRUNK SEWER AND MH
	EX. TRIBUTARY STORM SEWER AND MH
	EX. CATCHBASIN
	EX. CATCHBASIN MANHOLE
	MAJOR SYSTEM OVERLAND FLOW ROUTE

NOVATECH
Engineers, Planners & Landscape Architects
Suite 200, 240 Mitchell Comp Lane Drive
Ottawa, Ontario, Canada K2M 1P6
Telephone: (613) 254-5623
Facsimile: (613) 254-5627
Website: www.novatech-eng.com

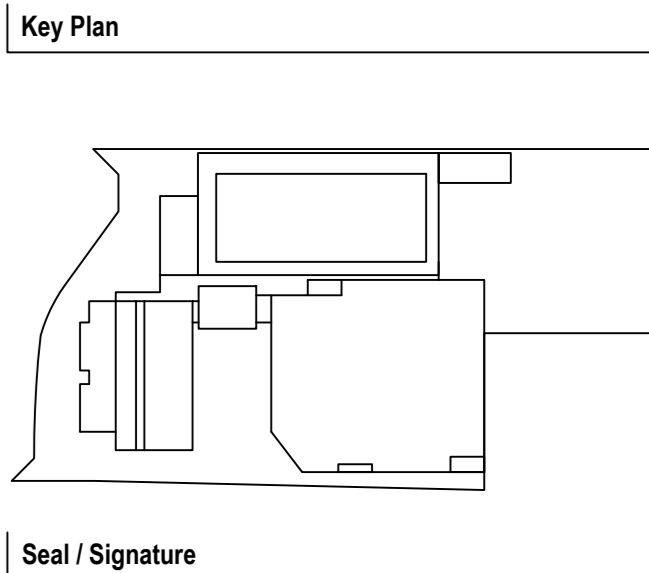

NOT FOR CONSTRUCTION

Project Name
Nokia Ottawa Campus

Project Number
027.7946.000

Description
STORM DRAINAGE AREA PLAN - NORTH OUTLET

Scale
1 : 750

C500

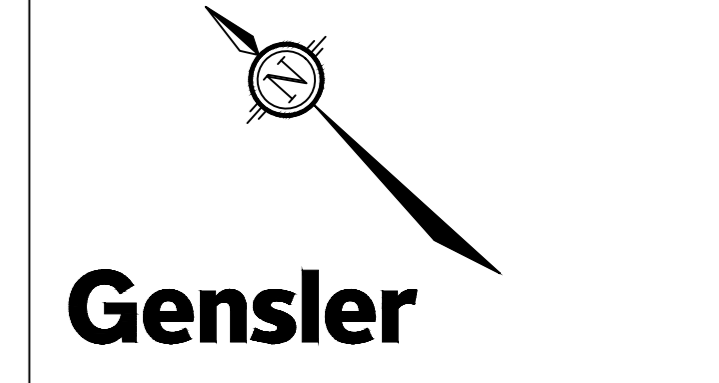

5005 Greenville Ave
Dallas TX 75206
Tel 214.273.1500

Surveyor
Avinia, D'Silva, Vukobrah Ltd
Planning Consultant
Novatech
Civil Engineering
Novatech
Architectural Site Planning
Gensler
Mechanical Engineering
Smith and Anderson
Mechanical Engineering Study
Smith and Anderson
Geotechnical Engineering
GSI
Landscape Planning
GSI
Structural Engineering
A&S
Noise Report
Graham Hill
Transportation Planners
Starrac
Starrac

Date	Description
NOV 15/24	ISSUED FOR SITE PLAN CONTROL APPROVAL

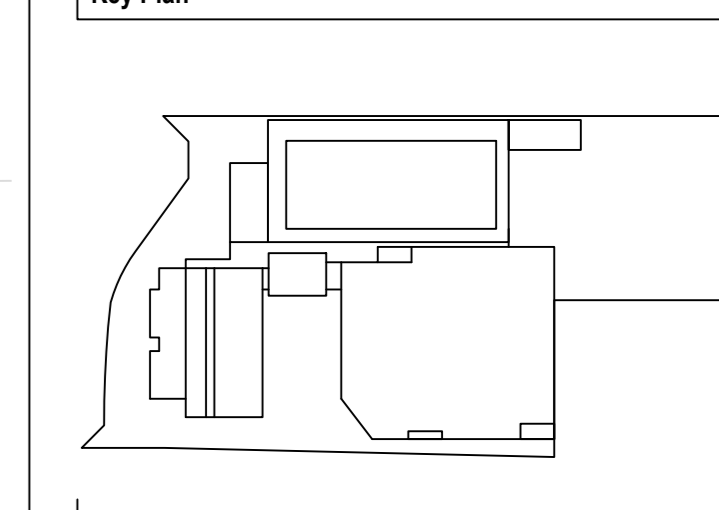
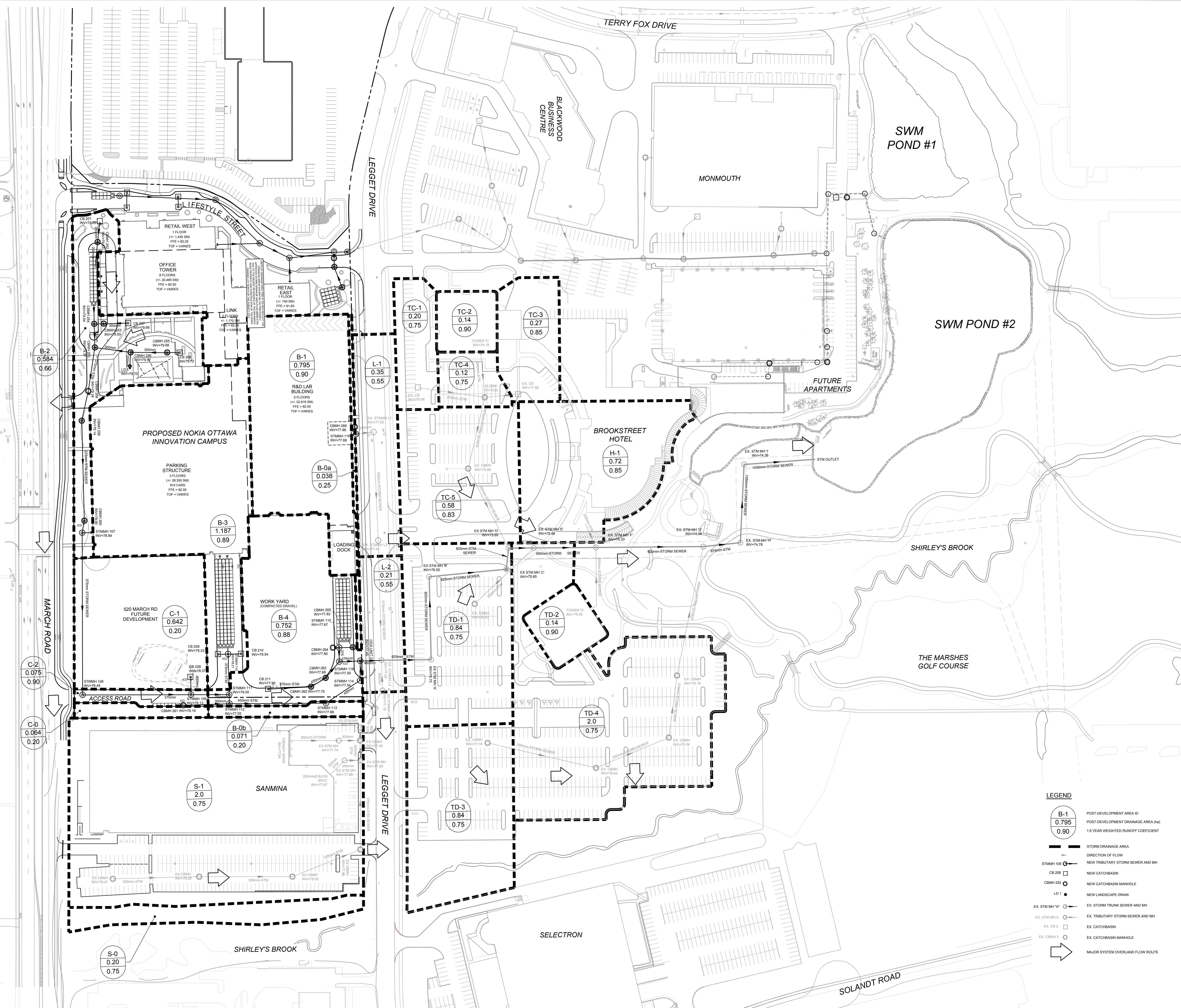

Seal / Signature

NOT FOR CONSTRUCTION

Project Name
Nokia Ottawa Campus

Project Number
027.7946.000

Description
STORM DRAINAGE AREA PLAN - SOUTH OUTLET

Scale
1 : 750

C501

LEGEND

- POST-DEVELOPMENT AREA ID
0.795
0.90
15 YEAR WEIGHTED RUNOFF COEFFICIENT
- STORM DRAINAGE AREA
- DIRECTION OF FLOW
- NEW TRIBUTARY STORM SEWER AND MH
- NEW CATCHBASIN
- NEW CATCHBASIN MANHOLE
- NEW LANDSCAPE DRAIN
- EX. STORM TRUNK SEWER AND MH
- EX. TRIBUTARY STORM SEWER AND MH
- EX. CATCHBASIN
- EX. CATCHBASIN MANHOLE
- MAJOR SYSTEM OVERLAND FLOW ROUTE

LEGEND

SAN MH 1	PROPOSED SANITARY MANHOLE AND SEWER	PROPOSED BUILDING ENTRANCE
CBMH 250	PROPOSED CATCHBASIN MANHOLE	EXISTING CONCRETE CURB
STMMH 100	PROPOSED STORM MANHOLE AND SEWER	EXISTING SANITARY MANHOLE
CS 200	PROPOSED CATCHBASIN	EXISTING CATCHBASIN MANHOLE
LD 1	PROPOSED LANDSCAPE DRAIN	EXISTING STORM MANHOLE
	THERMAL INSULATION FOR SHALLOW SEWERS	EXISTING CATCHBASIN
HYD	PROPOSED HYDRANT AND VALVE	EXISTING HYDRANT & VALVE
V&V	PROPOSED VALVE BOX	EXISTING TREES / VEGETATION
VC	PROPOSED VALVE CHAMBER	EXISTING UTILITY POLE / CM / GUY / MANS
RED	PROPOSED REDUCER	EXISTING FENCE
	PROPOSED BARRIER CURB (PER SC1-1)	EXISTING LIGHT STANDARD
DC	PROPOSED DEPRESSED CURB (PER SC1-1)	REMOVALS
CC	PROPOSED CURB CUT	
ICD	PROPOSED INLET CONTROL DEVICE	FULL ASPHALT OVERLAY PER CITY STANDARD R10

BENCHMARK NOTES:

- ELEVATIONS SHOWN ARE GEODETIC AND ARE REFERRED TO THE CGVD28 GEODETIC DATUM.
- IT IS THE RESPONSIBILITY OF THE USER OF THIS INFORMATION TO VERIFY THAT THE JOB BENCHMARK HAS NOT BEEN ALTERED OR DISTURBED AND THAT ITS RELATIVE ELEVATION AND DESCRIPTION AGREES WITH THE INFORMATION SHOWN ON THIS DRAWING.
- BENCHMARKS WERE PROVIDED ON THE TOPOGRAPHIC PLAN OF SURVEY OF BLOCK 6 AND PART OF BLOCK 1 REGISTERED PLAN 484-42 AND PART OF LOTS 8 AND 9 CONVEYANCE 4 GEOGRAPHIC TOWNSHIP OF MARCH, CITY OF OTTAWA, SURVEYED BY ANNIS, O'SULLIVAN AND VOLEBERK LTD, SIGNED AND DATED FEBRUARY 20, 2022.

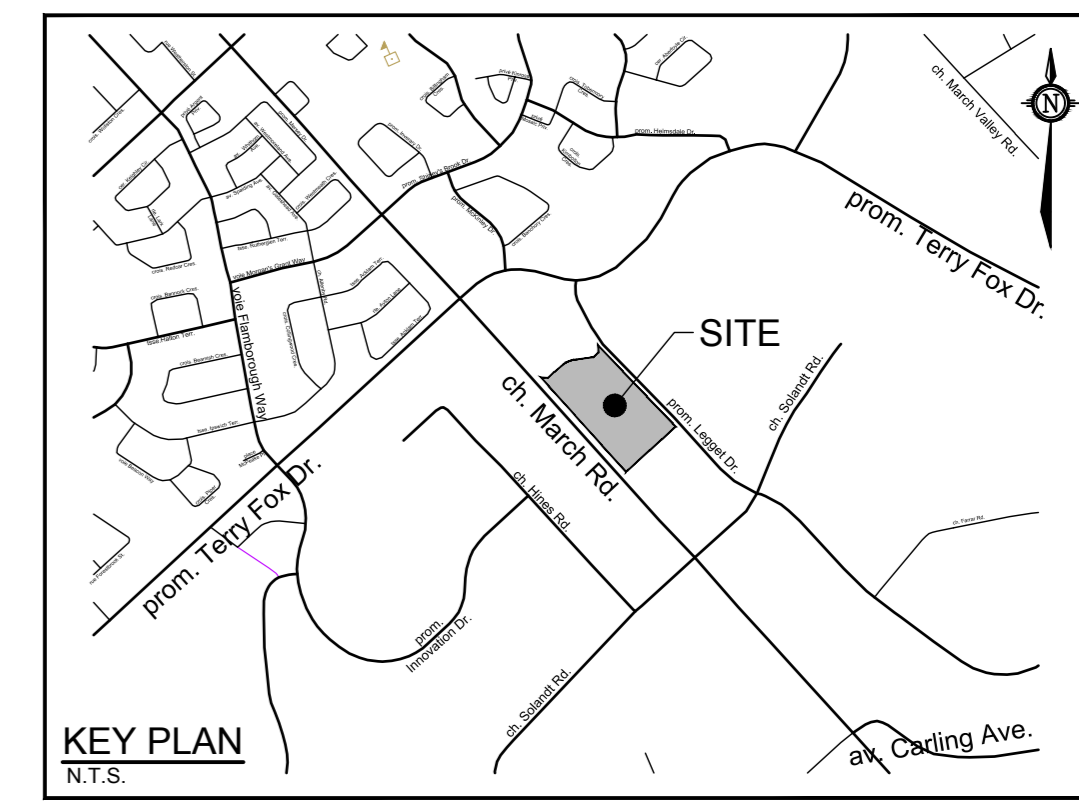

NOKIA Ottawa Campus
 570 March Rd, Kanata Ottawa ON K2K 2T6

Gensler

5005 Greenville Ave
 Dallas TX 75206
 Tel 214.273.1500

Surveyor: Annis, O'Sullivan, Voleberk Ltd
 Planning Consultant: Novatech
 Civil Engineering: Novatech
 Architectural Site Planning: Novatech
 Geotechnical Engineering: Gensler
 Mechanical Engineering: Smith and Anderson
 Structural Engineering: Gensler
 Landscape Planning: Gensler
 Noise Report: Gensler
 Transportation Planners: Starlec

Date	Description
NOV 15/24	ISSUED FOR SITE PLAN CONTROL APPROVAL

WATERMAIN LAYOUT AND EXTENTS OF ASPHALT REINSTATEMENT TO BE REVISED FOLLOWING FINALIZATION OF THE WATERMAIN DESIGN.

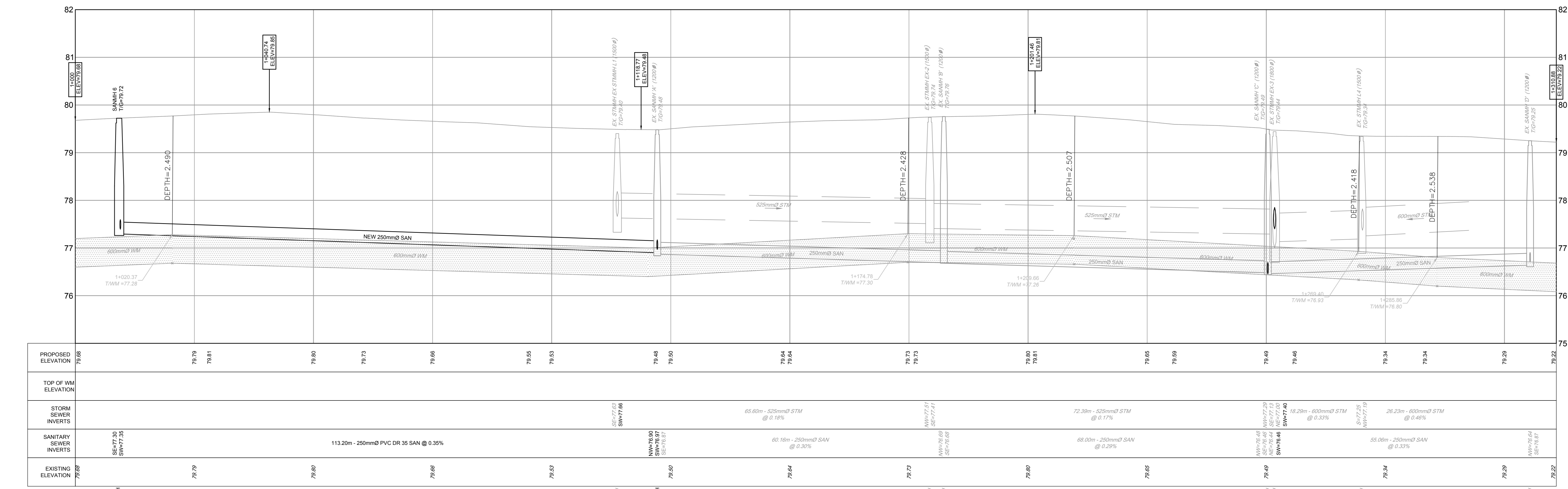
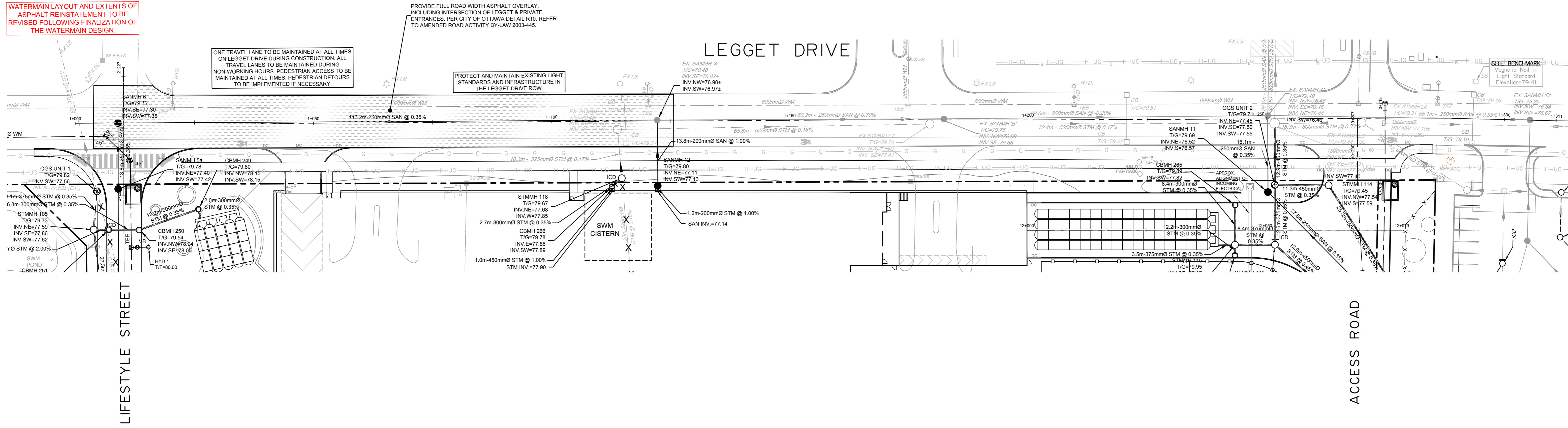

CHAINAGE	PROPOSED ELEVATION	TOP OF WM ELEVATION	STORM SEWER INVERTS	SANITARY SEWER INVERTS	EXISTING ELEVATION
1+000	79.88				79.88
1+008.95 SANMH		79.79		86.72.00 SAN+77.35	79.79
1+025	79.81				79.81
1+050	79.80			113.20m - 200mm PVC DR 35 SAN @ 0.35%	79.80
1+075	79.73				79.73
1+100	79.66				79.66
1+125	79.55				79.55
1+150	79.53				79.53
1+177.77 STMMH		79.45		65.00m - 250mm SAN @ 0.29%	79.45
1+202.17 SANMH		79.50			79.50
1+225	79.64			65.00m - 250mm SAN @ 0.30%	79.64
1+250	79.54				79.54
1+277.27 STMMH		79.73		72.30m - 525mm STM @ 0.17%	79.73
1+300	79.80				79.80
1+325	79.85			65.00m - 250mm SAN @ 0.29%	79.85
1+350	79.59				79.59
1+377.27 STMMH		79.49		18.20m - 600mm STM @ 0.33%	79.49
1+400	79.46				79.46
1+425	79.34			26.20m - 600mm STM @ 0.46%	79.34
1+450	79.34			55.00m - 250mm SAN @ 0.33%	79.34
1+500	79.29				79.29
1+518.88	79.22				79.22

NOVATECH
 Engineers, Planners & Landscape Architects
 Suite 200, 140 Michael Cowpland Drive
 Ottawa, Ontario, Canada K2M 1R6
 Telephone: (613) 254-9643
 Facsimile: (613) 254-5667
 Website: www.novatech-eng.com

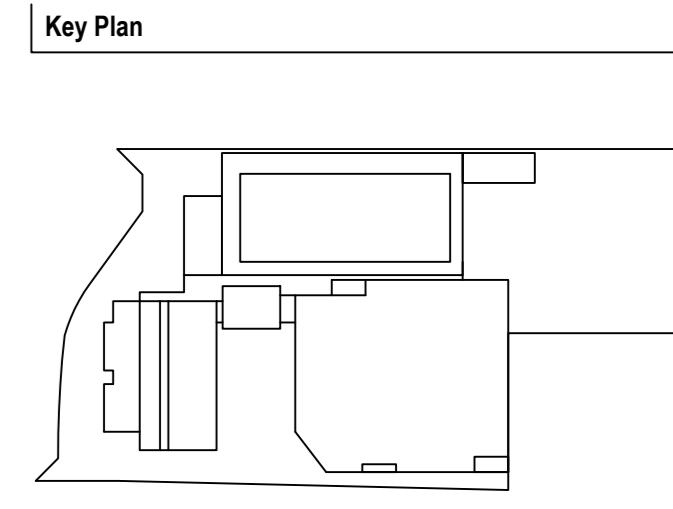

Seal / Signature

NOT FOR CONSTRUCTION

Project Name
Nokia Ottawa Campus

Project Number
027.7946.000

Description
**PLAN AND PROFILE
 LEGGET DRIVE
 STATION 1+000 TO 1+310**

Scale
 HORIZONTAL: 1:400
 VERTICAL: 1:40

C601

REFER TO DRAWING C-100 FOR ADDITIONAL NOTES

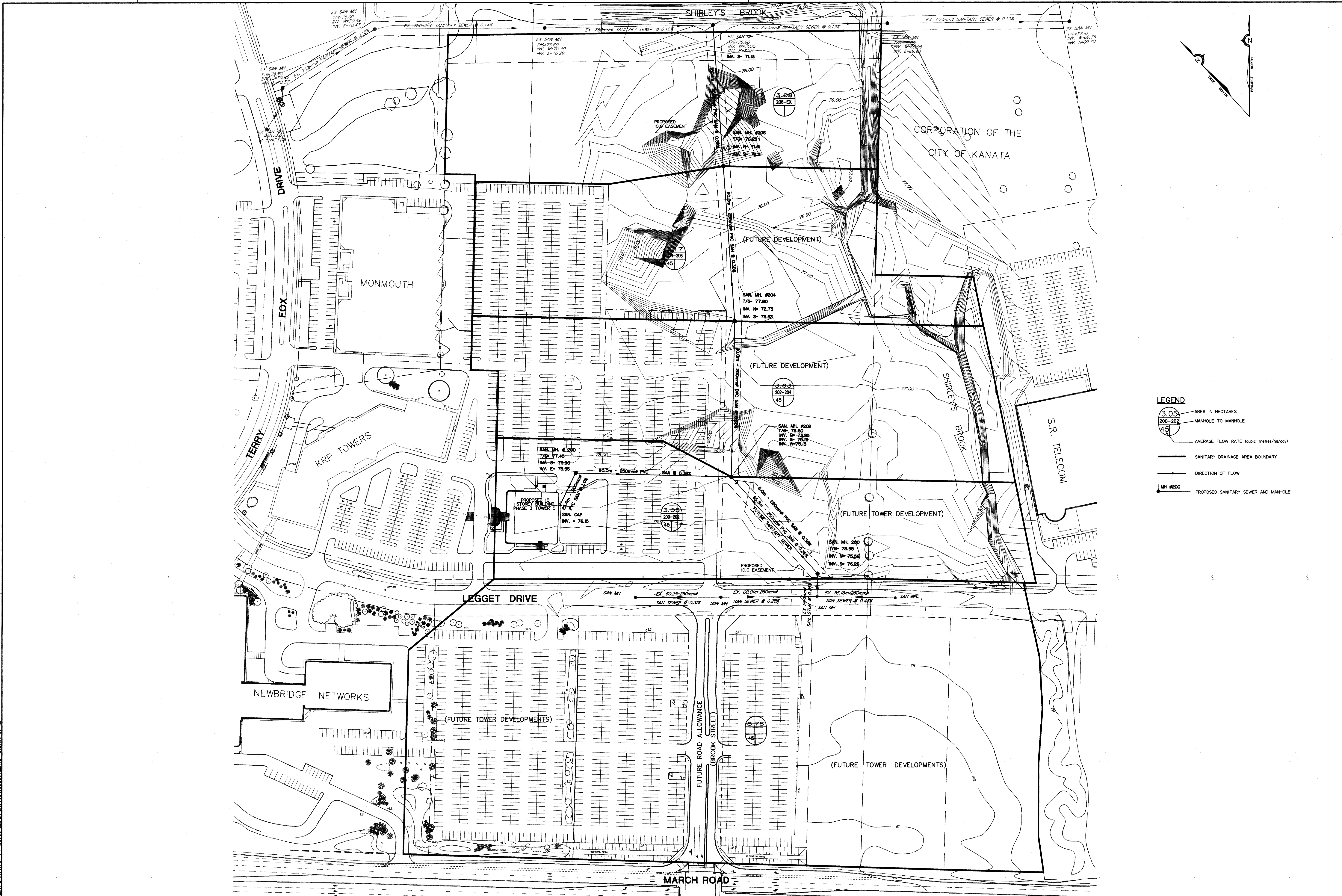

- LEGEND**
- 3.05
200-202
4.9 AREA IN HECTARES
 - 200-202
4.9 MANHOLE TO MANHOLE
 - $\frac{3.05}{4.9}$ AVERAGE FLOW RATE (cubic metres/hr/day)
 - SANITARY DRAINAGE AREA BOUNDARY
 - DIRECTION OF FLOW
 - MH #200 PROPOSED SANITARY SEWER AND MANHOLE

NOTE:
THE POSITION OF ALL POLE LINES, CONDUITS, WATERMANS,
SEWERS AND OTHER UNDERGROUND AND OVERGROUND
UTILITIES AND STRUCTURES IS NOT NECESSARILY
SHOWN ON THE CONTRACT DRAWINGS, AND WHERE
SHOWN, THE ACCURACY OF THE POSITION OF SUCH
UTILITIES AND STRUCTURES IS NOT GUARANTEED.
BEFORE STARTING WORK, DETERMINE THE EXACT
LOCATION OF ALL SUCH UTILITIES AND STRUCTURES
AND ASSUME ALL LIABILITY FOR DAMAGE TO THEM.

KANATA RESEARCH PARK
 Kanata Research Park
 555 Legget Drive, Suite 100, Kanata, Ontario, Canada, K2L 2Z2
 (613) 591-8984

No.	REVISION	DATE	BY
1	ISSUED FOR COMMENTS	DEC. 11/98	GSH

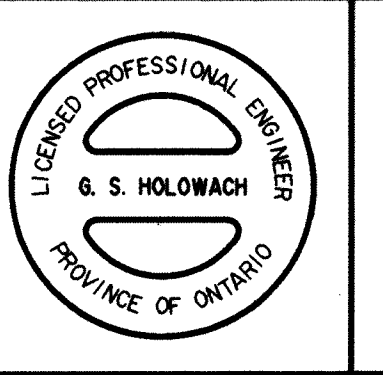
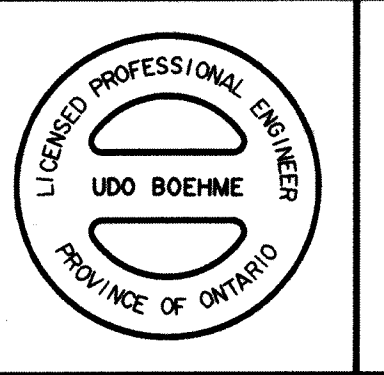

NOVATECH
 CONSULTING ENGINEERS & PLANNERS
 Suite 17, 77 Auriga Drive
 Nepean, Ontario
 K2E 7Z1
 Telephone (613) 727-1658
 Facsimile (613) 727-6972

DESIGN	SCALE
CHECKED UB	1:1000
DRAWN DU	
CHECKED GSH	
APPROVED UB	

CITY OF KANATA
**KANATA RESEARCH PARK
 TOWER 'C' PROJECT**
SANITARY DRAINAGE AREA PLAN

PROJECT NO. 98066
 DATE SEPTEMBER 1998
 DRAWING NO. 98066-SAN

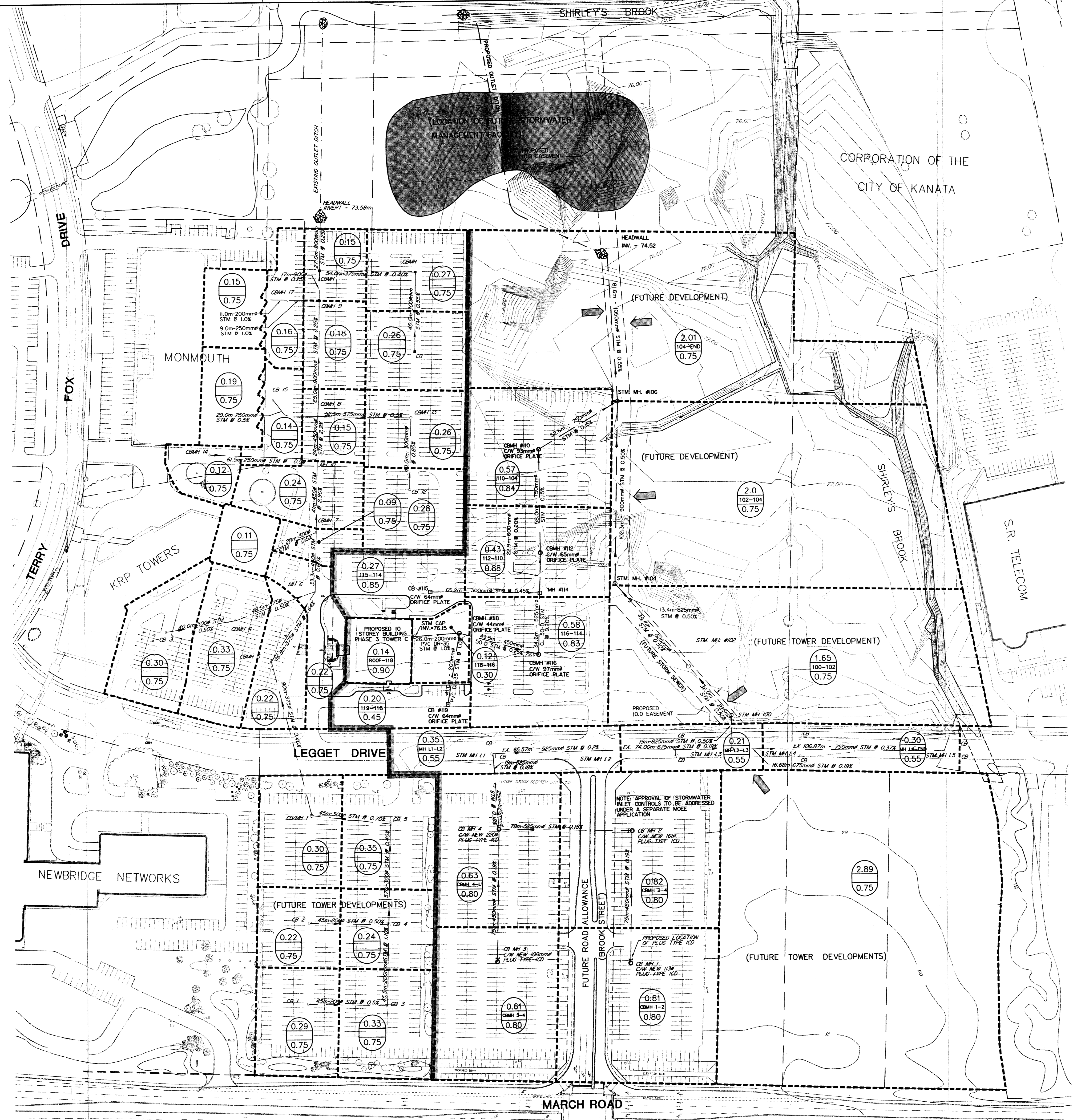
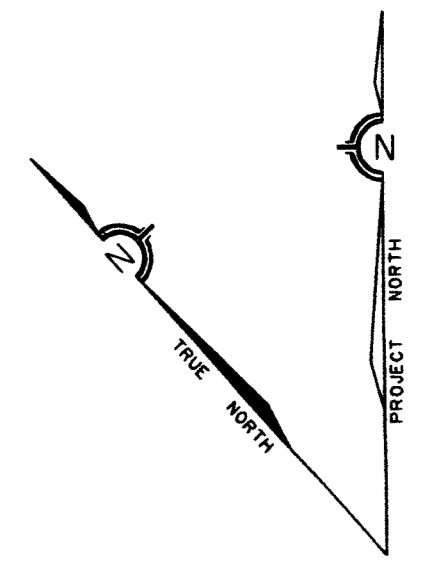

- LEGEND**
- 2.02 (circled) DRAINAGE AREA (hectares)
 - 100-102 (circled) MANHOLE TO MANHOLE
 - 0.6 (circled) RUN-OFF COEFFICIENT
 - STORM DRAINAGE AREA
 - STORM DRAINAGE AREA BOUNDARY
 - MH #100 EXISTING STORM SEWER AND MANHOLE
 - CBM# #116 EXISTING CATCHBASIN MANHOLE
 - CB #119 EXISTING CATCHBASIN
 - DIRECTION OF FLOW
 - ← MINOR STORM SYSTEM FLOW ROUTING (UNDEVELOPED AREAS)

- NOTE:**
1. RUNOFF COEFFICIENTS FOR TOWER 'C' PHASE 3 DEVELOPMENT ARE AS OUTLINED IN "KANATA RESEARCH PARK - TOWER 'C' STORMWATER MANAGEMENT REPORT" (NECL, Dec 1998)
 2. APPROVAL OF STORMWATER INLET CONTROLS FOR THE EXISTING NEWBRIDGE PARKING LOT (PLUG TYPE ICD'S) TO BE ADDRESSED UNDER A SEPARATE MOEE APPLICATION.

NOTE:
THE POSITION OF ALL POLE LINES, CONDUITS, WATERMANS, SEWERS AND OTHER UNDERGROUND AND OVERGROUND UTILITIES AND STRUCTURES IS NOT NECESSARILY SHOWN ON THE CONTRACT DRAWINGS, AND WHERE SHOWN, THE ACCURACY OF THE POSITION OF SUCH UTILITIES AND STRUCTURES IS NOT GUARANTEED. BEFORE STARTING WORK, DETERMINE THE EXACT LOCATION OF ALL SUCH UTILITIES AND STRUCTURES AND ASSUME ALL LIABILITY FOR DAMAGE TO THEM.

KANATA RESEARCH PARK
 Kanata Research Park
 555 Legget Drive, Suite 300, Kanata, Ontario, Canada, K1R 3T3
 416-811-1114

No.	REVISION	DATE	BY
2	REVISED STORM SEWER PER R.M.O.C. COMMENTS	APR. 15/99	GSH
1	ISSUED FOR COMMENTS	DEC. 11/98	GSH

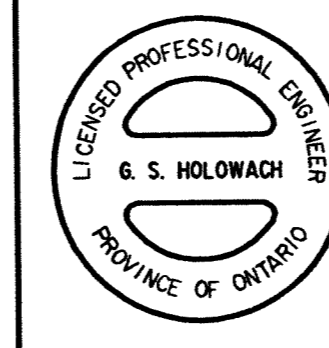

Novatech
 CONSULTING ENGINEERS & PLANNERS
 Suite 17, 77 Auriga Drive
 Nepean, Ontario
 K2E 7Z7
 Telephone: (613) 727-1658
 Facsimile: (613) 727-6972

DESIGN	SCALE
GSH	1:1000
CHECKED: UB	
DRAWN: DU	
CHECKED: GSH	
APPROVED: UB	

CITY OF KANATA
**KANATA RESEARCH PARK
 TOWER 'C' PROJECT**
STORM DRAINAGE AREA PLAN

PROJECT No.	DATE	DRAWING No.
98066	SEPTEMBER 1998	98066-STM

PL 15, 1999 - E-4815 - DWG Name: JANDOVAK - R - P-UBS06A-DESIGN-2APR99-1806655-TM-DWG Updated By: ZAM
 P:\proj\design\12\ap99\9806655-TM-DWG.Layout: 8/10/2007 3:00:36 PM, smithswe, Xerox EQ.pcl, B1, 11