



# **Earl of March Secondary School (OCDSB)**

**Transportation Impact Assessment Report**

**Final**

**November 2024**



## **TIA Plan Reports**

On 14 June 2017, the Council of the City of Ottawa adopted new Transportation Impact Assessment (TIA) Guidelines. In adopting the guidelines, Council established a requirement for those preparing and delivering transportation impact assessments and reports to sign a letter of certification.

Individuals submitting TIA reports will be responsible for all aspects of development-related transportation assessment and reporting, and undertaking such work, in accordance and compliance with the City of Ottawa's Official Plan, the Transportation Master Plan and the Transportation Impact Assessment (2017) Guidelines.

By submitting the attached TIA report (and any associated documents) and signing this document, the individual acknowledges that s/he meets the four criteria listed below.

### **CERTIFICATION**

1. I have reviewed and have a sound understanding of the objectives, needs and requirements of the City of Ottawa's Official Plan, Transportation Master Plan and the Transportation Impact Assessment (2017) Guidelines;
2. I have a sound knowledge of industry standard practice with respect to the preparation of transportation impact assessment reports, including multi modal level of service review;
3. I have substantial experience (more than 5 years) in undertaking and delivering transportation impact studies (analysis, reporting and geometric design) with strong background knowledge in transportation planning, engineering or traffic operations; and
4. I am either a licensed<sup>1</sup> or registered<sup>2</sup> professional in good standing, whose field of expertise [check  appropriate field(s)] is either transportation engineering  or transportation planning .

**1,2 License of registration body that oversees the profession is required to have a code of conduct and ethics guidelines that will ensure appropriate conduct and representation for transportation planning and/or transportation engineering works.**

City Of Ottawa  
Infrastructure Services and Community  
Sustainability  
Planning and Growth Management  
110 Laurier Avenue West, 4th fl.  
Ottawa, ON K1P 1J1  
Tel. : 613-580-2424  
Fax: 613-560-6006

Ville d'Ottawa  
Services d'infrastructure et Viabilité des  
collectivités  
Urbanisme et Gestion de la croissance  
110, avenue Laurier Ouest  
Ottawa (Ontario) K1P 1J1  
Tél. : 613-580-2424  
Télécopieur: 613-560-6006

Dated at Ottawa this 13 day of November, 2024.  
(City)

Name: Jake Berube  
(Please Print)

Professional Title: Transportation Engineer

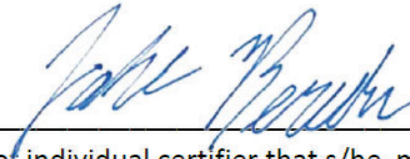
  
\_\_\_\_\_  
Signature of individual certifier that s/he meets the above criteria

<b>Office Contact Information (Please Print)</b>
Address: 1223 Michael Street North, Suite 100
City / Postal Code: Ottawa, Ontario, K1J 7T2
Telephone / Extension: 613-738-4160
E-Mail Address: jake.berube@parsons.com



Earl of March Secondary School (OCDSB)

# Transportation Impact Assessment Report

prepared for:

Edward J Cuhaci and Associates Architects Inc.  
171 Slater St, Suite 100  
Ottawa, ON  
K1P 5H7

prepared by:



1223 Michael Street North  
Suite 100  
Ottawa, ON K1J 7T2

November 13, 2024

479060-01000

---

## DOCUMENT CONTROL PAGE

<b>CLIENT:</b>	Edward J Cuhaci and Associates Architects Inc.
<b>PROJECT NAME:</b>	Earl of March Secondary School (OCDSB)
<b>REPORT TITLE:</b>	TIA Step 4 – Final Report
<b>PARSONS PROJECT NO:</b>	479060 - 01000
<b>VERSION:</b>	Site Plan Application (SPA)
<b>DIGITAL MASTER:</b>	<a href="https://parsons365can.sharepoint.com/sites/OttawaHub/Projects/Projects/479060 - OCDSB Earl of March (Cuhaci)/4. 01000 - WBS NAME/Documents/Step 4 - Final TIA/Earl of March School - Step 4 Final TIA.docx">https://parsons365can.sharepoint.com/sites/OttawaHub/Projects/Projects/479060 - OCDSB Earl of March (Cuhaci)/4. 01000 - WBS NAME/Documents/Step 4 - Final TIA/Earl of March School - Step 4 Final TIA.docx</a>
<b>ORIGINATOR</b>	Juan Lavin, P.Eng.
<b>AUTHORIZATION:</b>	Jake Berube, P.Eng.
<b>CIRCULATION LIST:</b>	Josianne Gervais, P.Eng.
<b>HISTORY:</b>	<ul style="list-style-type: none"><li>• TIA Step 1 Screening Form – April 12, 2024</li><li>• TIA Step 2 Scoping &amp; Forecasting Report – May 28, 2024</li><li>• TIA Step 3 Strategy Report – August 14, 2024</li><li>• TIA Step 4 Final Report – November 13, 2024</li></ul>

# TABLE OF CONTENTS

## EXECUTIVE SUMMARY

1.0	SCREENING FORM .....	3
2.0	SCOPING REPORT .....	3
2.1.	EXISTING AND PLANNED CONDITIONS .....	3
2.1.1.	PROPOSED DEVELOPMENT.....	3
2.1.2.	EXISTING CONDITIONS.....	5
2.1.3.	PLANNED CONDITIONS .....	12
2.2.	STUDY AREA AND TIME PERIODS.....	14
2.3.	EXEMPTION REVIEW .....	14
3.0	FORECASTING .....	15
3.1.	DEVELOPMENT GENERATED TRAVEL DEMAND .....	15
3.1.1.	TRIP GENERATION AND MODE SHARES.....	15
3.1.2.	TRIP DISTRIBUTION AND ASSIGNMENT .....	17
3.2.	BACKGROUND NETWORK TRAFFIC.....	19
3.2.1.	TRANSPORTATION NETWORK PLANS.....	19
3.2.2.	BACKGROUND GROWTH AND OTHER AREA DEVELOPMENTS .....	19
3.2.3.	FUTURE BACKGROUND VOLUMES .....	20
3.3.	DEMAND RATIONALIZATION .....	20
4.0	ANALYSIS .....	20
4.1.	DEVELOPMENT DESIGN .....	20
4.1.1.	DESIGN FOR SUSTAINABLE MODES.....	20
4.1.2.	CIRCULATION AND ACCESS.....	23
4.1.3.	NEW STREETS NETWORK .....	26
4.2.	PARKING .....	26
4.3.	BOUNDARY STREET DESIGN.....	26
4.4.	ACCESS INTERSECTION DESIGN .....	28
4.4.1.	LOCATION AND DESIGN OF ACCESS .....	28
4.5.	TRANSPORTATION DEMAND MANAGEMENT.....	30
4.5.1.	CONTEXT FOR TDM .....	30
4.5.2.	TDM PROGRAM .....	31
4.5.3.	NEED AND OPPORTUNITY .....	31
4.6.	NEIGHBOURHOOD TRAFFIC MANAGEMENT .....	31
4.7.	TRANSIT .....	31
4.7.1.	ROUTE CAPACITY.....	31
4.7.2.	TRANSIT PRIORITY.....	32
4.8.	REVIEW OF NETWORK CONCEPT .....	32
4.9.	INTERSECTION DESIGN.....	32
5.0	FINDINGS, CONCLUSIONS AND RECOMMENDATIONS.....	32

## LIST OF FIGURES

FIGURE 1:	LOCAL CONTEXT .....	3
FIGURE 2:	PROPOSED SITE PLAN (NOVEMBER 2024) .....	4

FIGURE 3: ADJACENT DRIVEWAYS WITHIN 200M OF SITE ACCESS .....	7
FIGURE 4: 2023 TMP CROSSTOWN BIKEWAY NETWORK .....	8
FIGURE 5: AREA TRANSIT NETWORK.....	9
FIGURE 6: BUS STOP LOCATIONS.....	9
FIGURE 7: EXISTING PEAK HOUR VEHICLE TRAFFIC VOLUMES .....	10
FIGURE 8: EXISTING PEDESTRIAN AND CYCLISTS PEAK HOUR VOLUMES .....	10
FIGURE 9: RECORDED LEFT-TURNING MOVEMENT COLLISION DIRECTIONS AT TERON/CAMPEAU .....	12
FIGURE 10: PRELIMINARY ALIGNMENT POSSIBLE MARCH/EAGLESON LRT STATION .....	12
FIGURE 11: OFFICIAL PLAN – ULTIMATE TRANSIT NETWORK .....	13
FIGURE 12: PROPOSED STUDY AREA AND INTERSECTIONS .....	14
FIGURE 13: SITE GENERATED VEHICLE TRAFFIC PERCENT DISTRIBUTION.....	18
FIGURE 14: NET NEW SITE-GENERATED TRAFFIC .....	19
FIGURE 15: FUTURE BACKGROUND TRAFFIC VOLUMES (2030) .....	20
FIGURE 16: EXISTING AND FUTURE ACTIVE TRANSPORTATION FACILITIES EXTERNAL TO THE SITE .....	21
FIGURE 17: FUTURE AND EXISTING ACTIVE TRANSPORTATION FACILITIES INTERNAL TO THE SITE .....	22
FIGURE 18: BUSES QUEUEING INTERNAL TO SITE DURING AFTERNOON PEAK HOUR .....	23
FIGURE 19: OBSERVED BUS CIRCULATION – EARL OF MARCH .....	24
FIGURE 20: BUS LAYBY LOCATIONS AND PROPOSED BUS CIRCULATION .....	25
FIGURE 21: ARTICULATED BUS TURNING IN AND OUT OF THE SITE .....	29
FIGURE 22: THE PARKWAY ACCESS – LANE ARRANGEMENTS AND GEOMETRY .....	30

## LIST OF TABLES

TABLE 1: EXEMPTIONS REVIEW SUMMARY.....	14
TABLE 2: EXISTING VEHICLE TRIPS OBSERVED FROM COUNTS.....	16
TABLE 3: EXISTING PEOPLE TRIP GENERATION BY MODE SHARE BASED ON FIRST PRINCIPLES .....	16
TABLE 4: NET NEW VEHICLE TRIPS WITH FUTURE EXPANSION.....	16
TABLE 5: NET NEW PERSON TRIPS WITH FUTURE EXPANSION.....	17
TABLE 6: HISTORIC TRAFFIC GROWTH – CAMPEAU/TERON.....	19
TABLE 7: REQUIRED VEHICLE AND BICYCLE PARKING SPACES .....	26
TABLE 8: MMLoS - BOUNDARY ROAD ANALYSIS.....	27

## LIST OF APPENDICES

APPENDIX A: TIA SCREENING FORM
APPENDIX B: TRANSIT ROUTE MAPS
APPENDIX C: EXISTING PEAK HOUR VOLUMES
APPENDIX D: HISTORIC COLLISION DATA
APPENDIX E: HISTORIC TRAFFIC GROWTH
APPENDIX F: TRUCK TURNING TEMPLATES
APPENDIX G: MMLoS: ROAD SEGMENTS
APPENDIX H: TDM CHECKLIST

# TIA FINAL REPORT

Parsons has been retained by Edward J Cuhaci and Associates Architects Inc. to prepare a TIA in support of a Site Plan Control Application for a proposed extension of the existing Earl of March Secondary School, part of the Ottawa Carleton District School Board (OCDSB). The school is located at the municipal address of 4 The Parkway. This document follows the TIA process as outlined in the City of Ottawa Transportation Impact Assessment (TIA) Guidelines (2017). The following report represents Step 4 – Final Report.

## 1.0 SCREENING FORM

The Screening Form confirmed the need for a TIA Report based on the Trip Generation Trigger only as the development is anticipated to generate more than 60 person trips during peak hours. None of the other triggers were met. The Screening Form and Site Plan have been provided in **Appendix A**.

## 2.0 SCOPING REPORT

### 2.1. Existing and Planned Conditions

#### 2.1.1. Proposed Development

The proposed development is bound by Teron Rd to the east and fronts Campeau Dr to the south, Beaverbrook Public Library and Beaverbrook Park to the west and The Parkway to the north as illustrated in **Figure 1**. The site is currently occupied by the Earl of March Secondary School (OCDSB) which has an attendance of approximately 2,300 students and 150 teachers/administrative/support personnel<sup>1</sup>. The proposed development which currently has 36 temporary portables plans to add a new fixed building extension comprising of 25 new classrooms within a 2-storey addition (3,150 m<sup>2</sup>), maintain 12 existing portables, relocate 12 other portables, and permanently remove 12 other portables, for a net increase of 13 classroom spaces. The future student attendance is forecasted at approximately 2,400 students. The site is currently zoned I1A (institutional).

The school addition proposes additional parking to meet demands, adjustments to the internal bus laybys and a new sidewalk connecting The Parkway to the new front door of the school extension. The site access locations will remain as existing, however minor refinements to the internal roadways are proposed as means of traffic calming, including bulb-outs. The proposed development is anticipated to be constructed in a single phase assumed by 2025. The site plan has been illustrated in **Figure 2**.

Figure 1: Local Context



<sup>1</sup> [https://earlofmarchss.ocdsb.ca/our\\_school](https://earlofmarchss.ocdsb.ca/our_school)



Figure 2: Proposed Site Plan (November 2024)

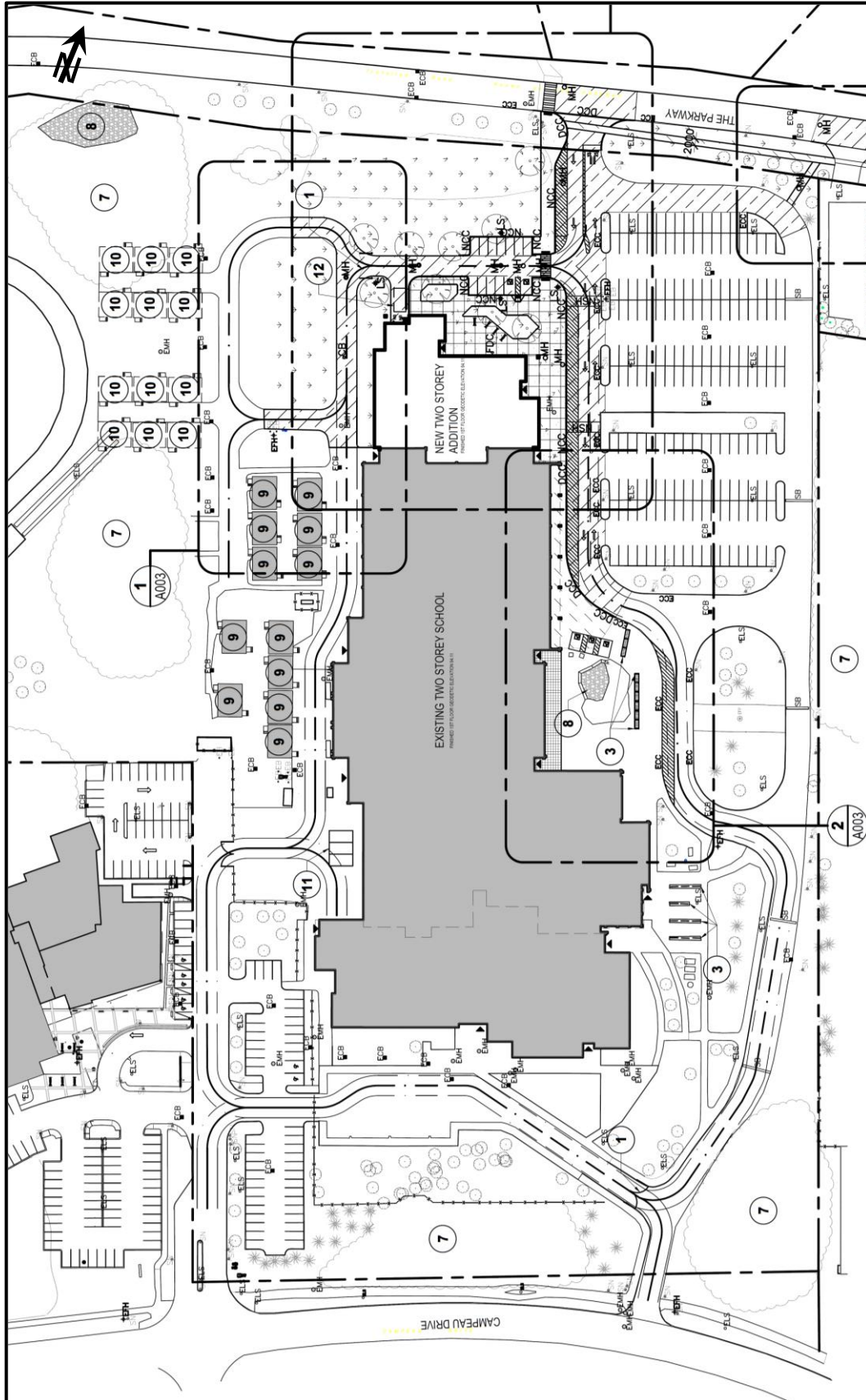

## 2.1.2. Existing Conditions

### Area Road Network

A description for each road within the study area included in the TIA has been provided below.

**Campeau Dr** is an east-west arterial road that extends from the Highway 417 interchange with March Rd in the east to approximately 230m west of Upper Canada St in the west. Within the study area, the roadway typically operates as a two-way two-lane undivided urban cross-section with long auxiliary left-turn storage lanes and a posted speed limit of 60 km/h. The protected to be right-of-way (ROW) is 40m. The existing ROW appears to vary along the site frontage but generally exceeds 40m according to GeoOttawa property parcels. The school extension does not plan to change the curb-to-curb or ROW along Campeau Dr.

**Teron Rd** is a north-south major collector road that extends from Carling Ave in the north to Campeau Dr in the south where it continues as Colchester Square. Within the study area, the roadway typically operates as a two-way two-lane undivided urban cross-section with a posted speed limit of 50 km/h.

**The Parkway** is an east-west collector road that extends from Teron Rd in the east (continues as Penfield Dr) to Leacock Dr in the west. Within the study area, the roadway typically operates as a two-way two-lane undivided urban cross-section with a posted speed limit of 40 km/h. The ROW to be protected for The Parkway is 26m, which appears to be consistent with GeoOttawa. The minor works proposed on the site access would not affect the ROW to be protected.

### Existing Study Area Intersections

#### Parkway Access/The Parkway

The Parkway Access intersection is a three-legged unsignalized intersection with a STOP-control on the northbound approach. All approaches consist of a single all-movement lane. Crosswalks are provided on the eastbound and northbound approaches only. All movements are permitted at this intersection.



#### Teron/The Parkway

The Teron/Parkway intersection is a four-legged signalized intersection. The southbound, eastbound and northbound approaches consist of a left-turn lane and a shared through-right lane. The westbound approach consists of a single all movement lane. Crosswalks are provided on all approaches except the southbound. All movements are permitted at this intersection.



### Teron/Campeau

The Teron/Campeau intersection is a four-legged signalized intersection. The southbound, and westbound approaches consist of a left-turn lane, a channelized right-turn lane and a through lane. The northbound approach consists of a right-turn lane and a shared through-left lane. The eastbound approach consists of a left-turn lane and a shared through-right lane. Crosswalks are provided on all approaches. All movements are permitted at this intersection.



### Campeau Access/Campeau

The Campeau Access intersection is a three-legged unsignalized intersection with a STOP-control on the southbound approach. The southbound approach functions as an exit only from the school with inbound traffic prohibited. The eastbound approach consists of a through lane only and the westbound approach has the origins of a left-turn (downstream intersection) and a through lane. A crosswalk is provided on the southbound approach only.



### Hawkstone/Campeau

The Hawkstone/Campeau intersection is a four-legged signalized intersection. The westbound, eastbound and northbound approaches consist of a left-turn lane and a shared through-right lane. The southbound approach consists of a single wide all movement lane. Crosswalks are provided on all approaches. All movements are permitted at this intersection.



### Existing Driveways to Adjacent Developments

Only driveways along The Parkway and Campeau Dr were considered as the site only fronts those two streets, as shown in **Figure 3**. Excluding the existing and maintained future Parkway Access, three other driveways were identified on The Parkway, all belonging to the residential building located at 2 The Parkway. The accesses are located approximately 65m, 95m, and 125m east of the Parkway Access. Along Campeau Dr, only a single driveway access was identified for the recreational facilities at the Beaverbrook Park, approximately 235m west of the Hawkstone/Campeau intersection, excluding the existing and maintained future Campeau Access.

Figure 3: Adjacent Driveways within 200m of Site Access



### **Existing Area Traffic Management Measures**

Existing area traffic management measures within the study area include school sign ahead and stop for pedestrians signs at the Parkway Access.

### **Existing Pedestrian/Cycling Network**

Sidewalks are provided on both sides of Hawkstone Gate south of Campeau Dr. A 3m wide multi-use pathway is provided on the north side of Campeau Dr and also on the north side of The Parkway west of the Parkway Access. East of the Parkway Access, a substandard and degraded pathway is provided on the south side of The Parkway. Teron Rd provides 2m asphalt pathways on each side of the road. Pathways are provided internal to the site from Campeau Dr to the front entrance and no active transportation facilities are provided from The Parkway to the school. On-road bike lanes are also available on Campeau Dr, originating approximately 100m west of Hawkstone Gate, and on Teron Rd.

The Crosstown Bikeway Network (March 1, 2023)<sup>2</sup> from the new Transportation Master Plan classifies Campeau Dr as crosstown bikeways as shown in **Figure 4**. Within the previous City of Ottawa's 2013 Cycling Plan, Campeau Dr is identified as a spine route, while the MUP on Campeau Dr and The Parkway are identified as major pathways.

<sup>2</sup> [Crosstown Bikeway Network, March 1, 2023](#)

Figure 4: 2023 TMP Crosstown Bikeway Network

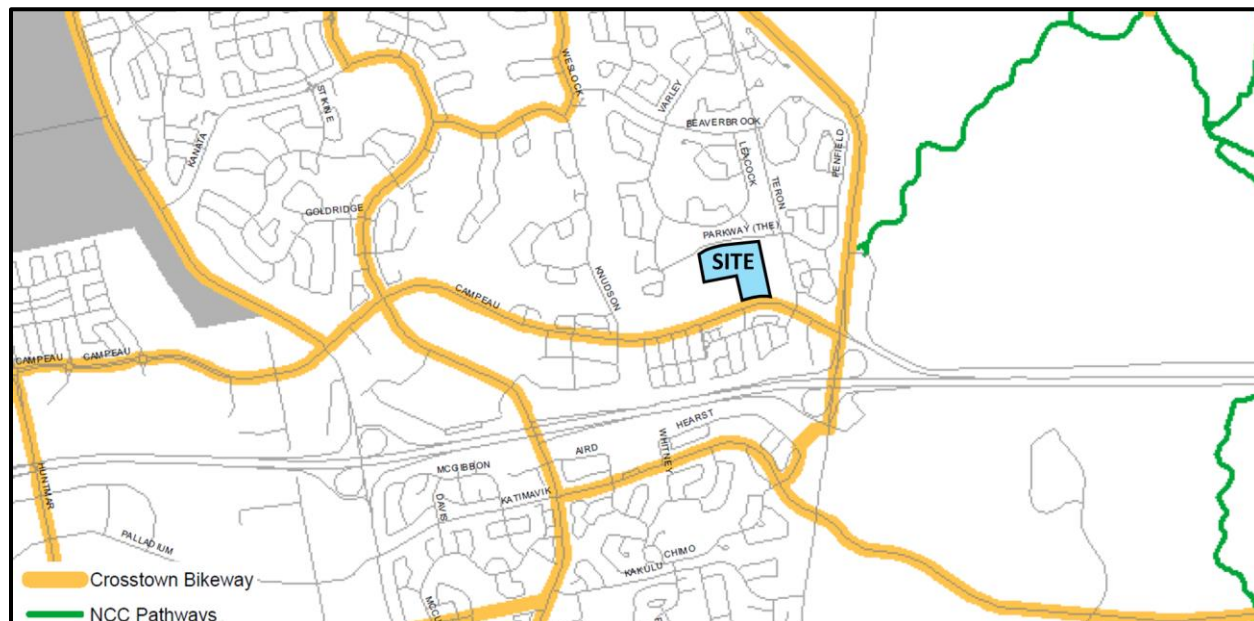

### Transit Network

The site is located along two well serviced transit corridors, including Teron Rd and Campeau Dr. The following description of OC Transpo routes within the study area are as follow:

- **Routes with a transit stop located internal to the site:** includes local routes #161 and #168, as well as school route #664. Although these routes operate 7 days a week (except on weekend evenings) and at an average headway of 30 minutes, they only serve the site during AM and PM peak hours internal to the site to provide improved student access during school hours. These bus routes do not serve the site during days and hours outside of the school morning and afternoon start and finish bells. Destinations include Terry Fox, Kanata Centrum, Kanata South Business Park, Eagleson, Fernbank, etc.
- **Route #62 (Tunney's Pasture <-> Terry Fox, Stittsville):** identified by OC Transpo as a "Rapid Route", this route operates all day, 7 days a week in all time periods. This route provides connectivity to the Confederation LRT Line at Tunney's Pasture, connectivity to Bayshore Shopping Center, Canadian Tire Center and other destinations within Kanata and Stittsville. The nearest bus stop to the site is located along Campeau Dr, located approximately 65m west from the Campeau Access.
- **Route #63 (Tunney's Pasture <-> Briarbrook via Innovation):** identified by OC Transpo as a "Rapid Route", this route operates all day, 7 days a week in all time periods. This route provides connectivity to the Confederation LRT Line at Tunney's Pasture, connectivity to Bayshore Shopping Center and other destinations within Kanata. The nearest bus stop to the site is located along Teron Rd, located approximately 175m east from the Parkway Access.
- **Additional routes with stops located on Campeau Dr (65m west of site):** includes local routes #161, #164, connexion routes #265, #268 and school route #688. Some major destinations and corridors include along Eagleson, Bayshore, and connection to LRT at Tunney's Pasture.
- **Additional routes with stops located on Teron Rd (175m east of site):** includes local routes #64, #110, #166, #168, and school routes #660 and #661. Some major destinations and corridors include along Fallowfield, Terry Fox, and Stittsville.

The transit network for the study area is illustrated in **Figure 5** with **Figure 6** illustrating the bus stop locations near to the site. Maps of active transit routes are included in **Appendix B**.

Figure 5: Area Transit Network

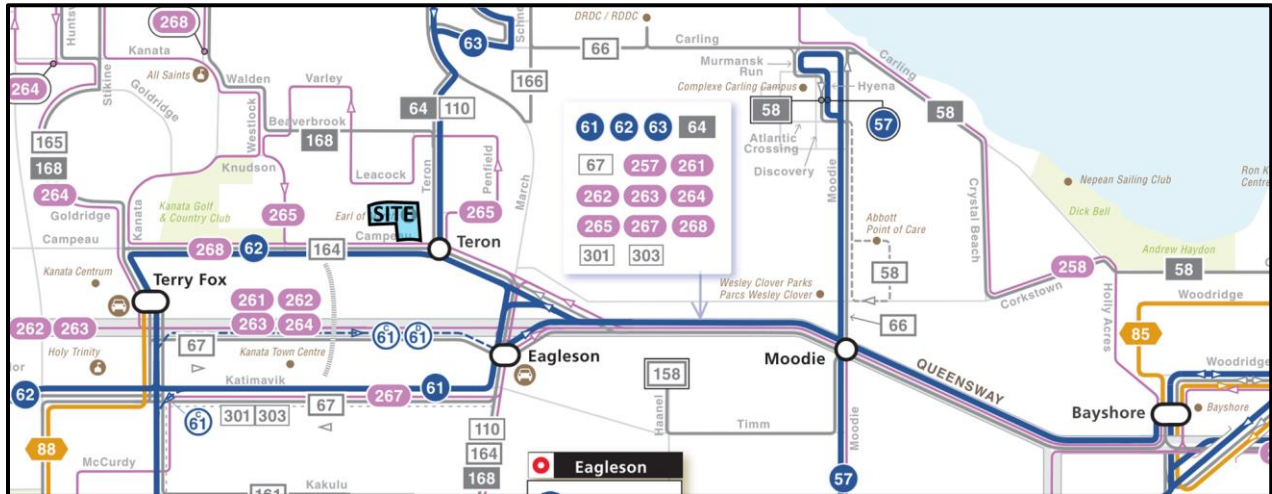

Figure 6: Bus Stop Locations



**Peak Hour Travel Demands**

Traffic count data was obtained from the City of Ottawa and performed by Parsons. The traffic volumes at study area intersections are illustrated in **Figure 7**, with raw traffic count data provided in **Appendix C**. Existing active transportations volumes have been provided in **Figure 8**. Note that school classes start at 8:40 AM and finish at 2:50 – 3:00 PM. The AM commuter peak hour is generally within the same timeframe that students and staff arrive to school by, but the PM commuter peak hour is generally understood to occur later than the peak departure timeframe for the school. For this reason, the 3:00-4:00 PM counts will be used for the PM peak hour.

Figure 7: Existing Peak Hour Vehicle Traffic Volumes

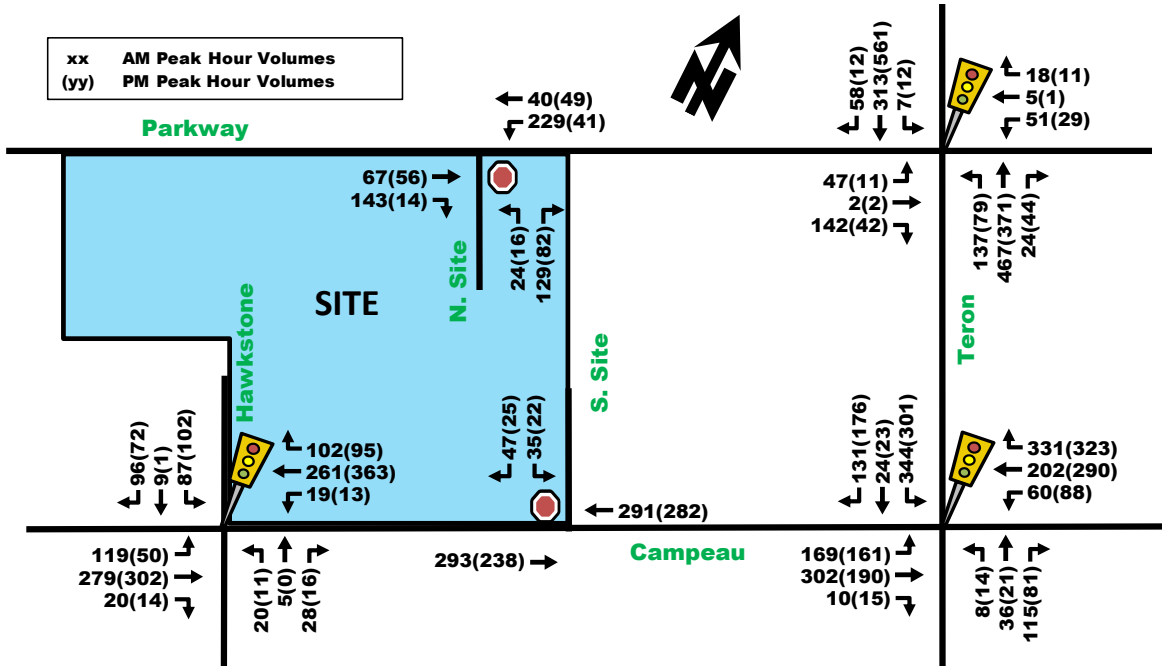
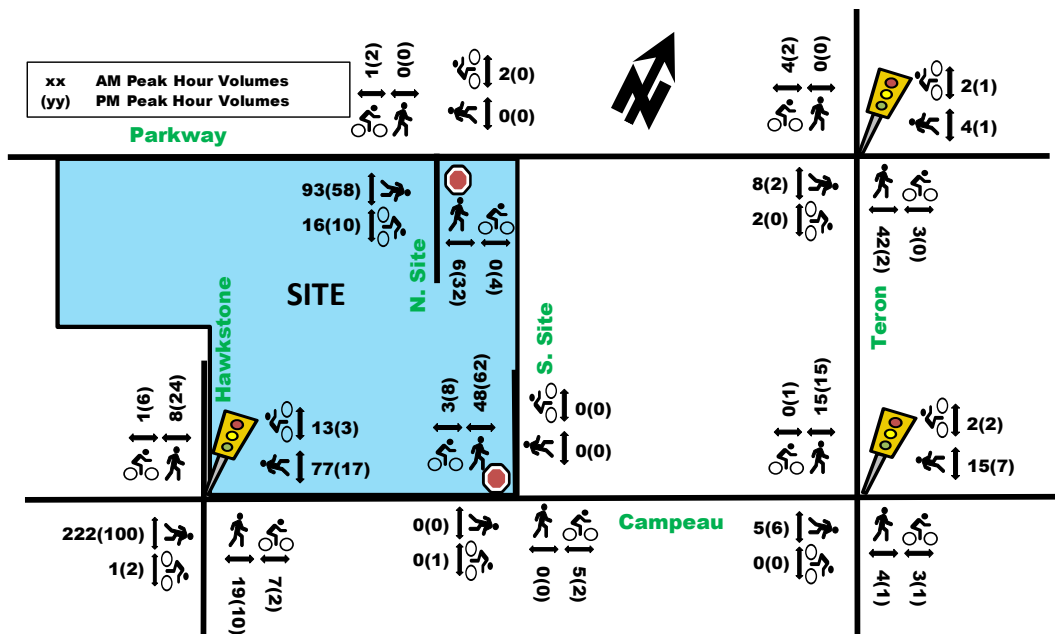

Figure 8: Existing Pedestrian and Cyclists Peak Hour Volumes



Note: some counts were performed in winter and may reflect lower than average AT users.

**Existing Road Safety Conditions**

A five-year collision history data (2018-2022, inclusive) was obtained from the City of Ottawa Open Data for the study area intersections, as well as road segments within the study area. Detailed collision analysis has been provided in **Appendix D**.

Upon analyzing the collision data, the total number of collisions observed within the study area was determined to be 40 collisions within the past five-years. About a third of the collisions (26 or 65%) resulted in property

damage only and 14 or 35% in non-fatal injury. There were no fatal collisions recorded within the study area. The type of impacts that were reported include: 20 (50%) turning movement, 14 (35%) rear end, 3 (8%) single vehicle other, 2 (5%) angle, and 1 (3%) other.

Within the study area, the quantity of collisions, collisions per million entering vehicles (MEV) and/or distance of mid-block at each location has occurred at a rate of:

- Parkway Access: 1, MEV 0.27
- Teron/Parkway: 8, MEV 0.36
- Campeau/Teron: 26, MEV 0.75
- Campeau Access: None recorded
- Hawkstone/Campeau: 3, MEV 0.27
- Mid-block on Parkway: None recorded (675m)
- Mid-block on Teron: 1 (425m)
- Mid-block on Campeau: 1 (525m)
- Collisions with Pedestrians: 2 (5%)
- Collisions with Cyclists: 1 (3%)

In general, the study area shows a lower-than-average frequency of collision compared other intersections and road segments within the City of Ottawa. Most intersections and road segments showed less than 6 collisions within the latest 5 years collision history, making collision patterns difficult to identify.

The Teron/Parkway intersection showed 1 collision involving a pedestrian causing minimal injury. The remaining active transportation collisions occurred at Hawkstone/Campeau, involving 1 pedestrian and 1 cyclist, representing 2 of 3 recorded incidents at this location. It is noteworthy that active transportation crossings are high at this intersection given the adjacent land uses, including a public library, parks and Earl of March School. The collisions involving pedestrians both resulted from vehicles turning, with the Teron/Parkway involving a left-turn and the Hawkstone/Campeau involving a right-turn. In both cases, the weather was clear during daylight, meaning that the road conditions did not play a role in the cause of the collision. The City of Ottawa could investigate improving active transportation user priority with measures such as leading pedestrian/cyclist intervals, protected intersection timings and no right on red right turns.

The higher frequency of registered collision counts at Teron/Campeau is expected at this location given the intersection of a major collector to arterial road and higher volumes associated with those routes. The majority of collision types at this intersection based on 2018-2022 open source data includes turning movement (62%). A further analysis was conducted using more detailed collision data requested from the City of Ottawa (2017-2021), where 31 total collisions were recorded, with 18 of them categorized as turning movement related (58%). All of these collisions involved a left-turning maneuver for vehicle 1 and a going ahead movement for vehicle 2. **Figure 9** illustrates the direction of vehicle travel at Teron/Campeau which resulted in turning movement collision types. A reoccurring pattern involving eastbound left-turns colliding with westbound through vehicles was observed, with 14 recorded collisions of this type. It is possible that the quantity of eastbound left-turns (permissive movement) and westbound through volumes plus the posted operating speed of 60km/h causes an environment where left-turners miss-judge the available gap time for their left-turning movement and opposing vehicle headed their direction. One option which could reduce this type of collisions at this location could include the implementation of a protected only eastbound left-turn movement, at the cost of increased delays and reduced intersection performance but improved safety.



Figure 9: Recorded Left-Turning Movement Collision Directions at Teron/Campeau

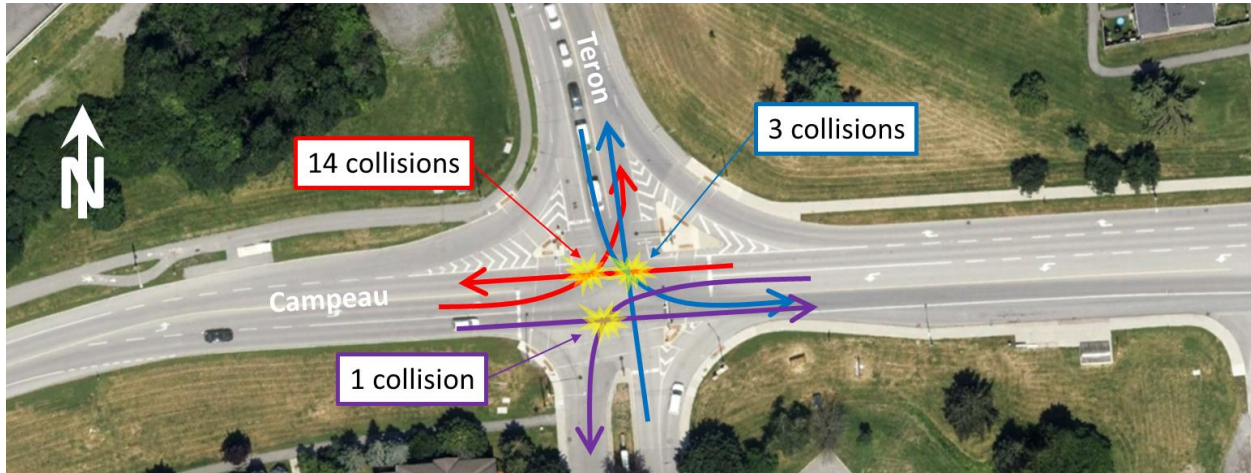

**2.1.3. Planned Conditions**

**Future Transportation Network Changes**

**Transportation Master Plan (TMP – 2013)**

Within the 2031 Network Concept (Map 10), Campeau Dr is identified as a widened arterial from March Rd to Didsbury Dr, however no concept plan for the widening was found. The City of Ottawa’s Construction and Infrastructure Projects website outlines Campeau Dr from March Rd to Kanata Dr as planned target start 1-2 years for “new roads”.

**Ottawa LRT Stage 2 & 3 (Stage 2 Began Construction 2019)**

Stage 2 of the City of Ottawa LRT system is currently under construction. Stage 2 is composed of three extensions – south, east and west – totaling 44 km of new rail and 24 new LRT stations. The westernmost station is located at Moodie Station, approximately 4kms east of the site.

The Stage 3 LRT Extension is not current funded. This extension would include expansion further south to Barrhaven Center and further west to Hazeldean Station, with a proposed LRT Station at March/Eagleson located approximately 600m walk from the southern edge of the site. A preliminary alignment of the possible future station has been illustrated in **Figure 10** and the general proposed Stage 3 LRT corridor illustrated in **Figure 11**.

Figure 10: Preliminary Alignment Possible March/Eagleson LRT Station

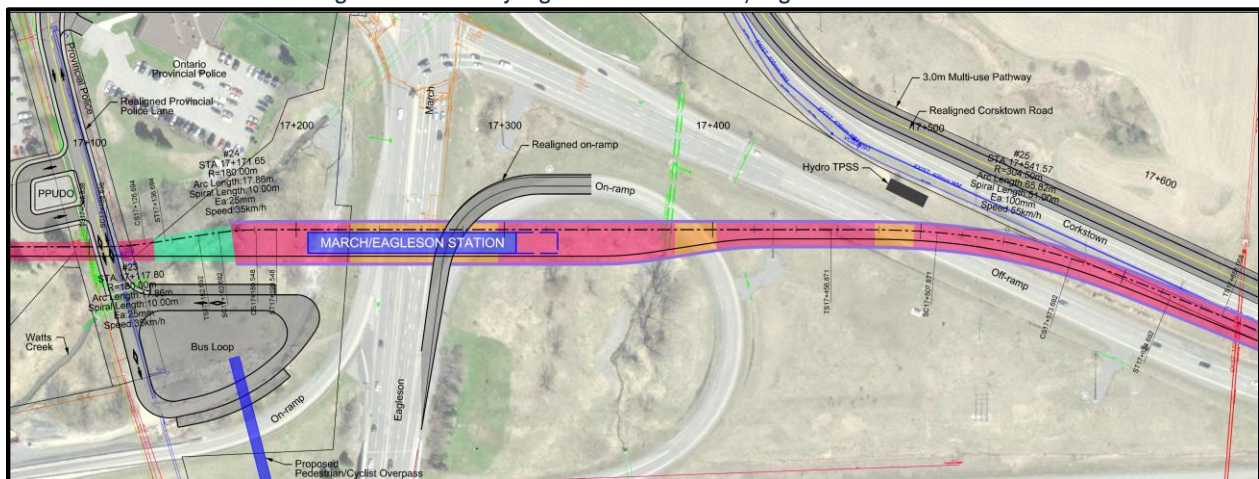

### Official Plan (2021)

In addition to the LRT Stage 3 Extension, the Official Plan proposes a transit priority corridor on March Rd, with future Corkstown/March Station located approximately 600m walk to the northern edge of the site. **Figure 11** illustrates the ultimate transit network which includes both the LRT Stage 3 extension and the March Rd BRT.

Figure 11: Official Plan – Ultimate Transit Network

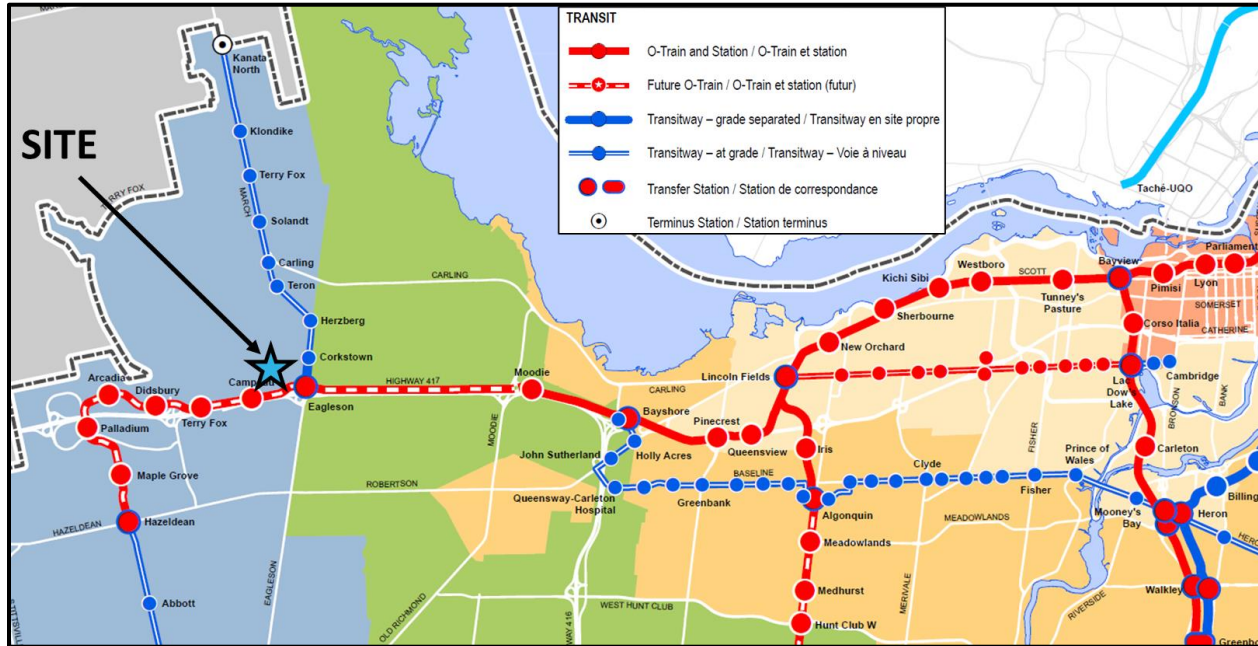

### Transportation Master Plan (2023 & On-Going)

An update to the 2013 Transportation Master Plan (TMP) is currently ongoing. Details such as policy and active transportation project list have been released, but a detailed network map such as the “affordable network” has not been released yet. The complete TMP update is forecasted for 2025. As shown previously on **Figure 4** Campeau Dr belongs to the Crosstown Bikeway Network based on the 2023 TM. There are no projects highlighted within the active transportation project list within the study area, however missing cycling links west of the study area on Campeau Dr and Kanata Ave are proposed to be completed, while a signage and pavement marking plan is proposed on Beaverbrook Rd to formalize bike lanes. A new sidewalk or pathway is proposed on Penfield Dr between Banting Cr and Petrie Ln.

### Other Proposed Planned Conditions

According to the City of Ottawa public engage website<sup>3</sup>, Varley Dr, Leacock Dr and Teron Rd which are located north and east of the site have new sidewalks proposed which would improve network connectivity for those walking to the school site.

### Other Area Developments

There are no active proposed developments within a 500m radius of the site. Slightly beyond 1km radius, there’s a proposal for a new hotel located at 1305 Maritime Way consisting of 102 rooms. A rezoning permit for a townhouse at 251 Penfield Dr was also found, but neither application has an associated transportation impact study and both are anticipated to produce negligible transportation impacts to the study area given their size and distance from the proposed site.

<sup>3</sup> <https://ottawa.ca/en/city-hall/public-engagement/public-engagement-project-search/varley-drive-leacock-drive-and-teron-road-sidewalks#>

## 2.2. Study Area and Time Periods

For the purposes of this report, the proposed development is assumed to be fully constructed by 2025. The full buildout scenario and five-years after development buildout would be 2025 and 2030. The future horizon years include weekday morning and afternoon peak hour traffic volumes. Proposed study area intersections are listed below and illustrated in **Figure 12**.

- Teron/Campeau
- Hawkstone/Campeau
- Campeau Access
- Teron/Parkway
- Parkway Access

Figure 12: Proposed Study Area and Intersections



## 2.3. Exemption Review

The following modules/elements of the TIA process provided in **Table 1** are recommended to be exempt in the subsequent steps of the TIA process, based on the City’s TIA guidelines and the subject site:

Table 1: Exemptions Review Summary

Module	Element	Exemption Consideration
4.1 Development Design	4.1.3 New Street Network	Only required for plans of subdivision
4.6 Neighborhood Traffic Calming	All	Development is not anticipated to meet criteria 3, 4 and 5.
4.8 Network Concept	All	Only required for ZBLA applications.
4.9 Intersection Design	All	The development is forecasted to generate less than 75 new vehicle trips.

## 3.0 FORECASTING

### 3.1. Development Generated Travel Demand

#### 3.1.1. Trip Generation and Mode Shares

Given that the proposed development is an extension of an existing site with the same land use, then a more accurate trip generation that can be prepared for future trip generation gathers data from the existing site and expands it to a future proportional growth. This methodology therefore retains existing commuting habits specific to this site.

#### **Trip Generation Rates**

The trip generation rates for this development have been derived using first principles based on traffic count data on a typical school day (April 22, 2024), with a focus on trips entering and leaving the site.

The school currently has two public accesses, a Parkway Access to The Parkway and a Campeau Access egress to Campeau Dr. Note that a fire route does exist around the western edge of the site connecting to the Beaverbrook Public Library, but the access appears to be gated and it is understood that it is not used by anyone. The following observations were made based on the data provided from the traffic counts:

- AM peak hour was determined to be 8:00-9:00, with approximately 90% of all trips arriving within this single peak hour.
- PM peak hour was determined to be 15:00-16:00, with approximately 45% of all trips departing within this single peak hour.
- Outbound trips in the AM peak hour were understood to be parent “drop-off/pick-up” trips.
- Inbound trips in the PM peak hour were understood to be parent “drop-off/pick-up” trips.
- The net difference in inbound and outbound trips during the AM hours were understood to be vehicles that arrived and parked on site, considered “primary trips”.

Based on these observations, the following assumptions were made:

- The existing population of the school consists of 2,300 students and 150 staff/support team. A 10% absentee per day has been assumed.
- The quantity of people trips generated for the AM peak hour was derived by reducing the school population by the absentee rate and multiplying that number by 90% to account for arrivals within the busiest peak hour.
  - It is understood that a large portion of staff tend to drive and stay for more than an hour after the dismissal bell. Some students also stay after hours for extra-curricular activities, sports, tutor courses, etc. While some students drive, it is estimated that the majority of primary vehicle trips originate from staff. Therefore, the 45% of vehicle trips departing the school during the PM peak hour is expected to be lower than the proportion of all people trips leaving the school.
  - Given that non-vehicle mode share data is challenging to capture accurately (i.e. predominantly students), the PM total people trip was calibrated based on ITE Trip Generation Manual (ITE land use 525 – high school) to represent approximately 62% of AM people trips.

**Table 3** summarizes the estimated existing trip generation for the school based on traffic counts conducted during a typical school day. Note that the values extrapolated were compared to ITE Trip Generation Manual 11<sup>th</sup> Edition for a High School land use for consistency and was found to have similar arrival and departure magnitudes for a school of a similar size. It was noted that the Earl of March PM peak hour was much more dispersed during the afternoon hours than the heaviest morning arrival hour.

Table 2: Existing Vehicle Trips Observed from Counts

Travel Mode	Equivalent Mode Share	AM Peak (Person Trips/hr) 08:00-09:00			Equivalent Mode Share	PM Peak (Person Trips/hr) 15:00-16:00		
		In	Out	Total		In	Out	Total
Vehicle Trips	19%	372	235	607	11%	55	145	200
<i>Primary Driver Trip</i>	7%	137	0	137	7%	0	90	90
<i>Vehicle Drop-Off/Pick-Up</i>	12%	235	235	470	4%	55	55	110
Total Person Trips <sup>1</sup>	100%			1,985	100%			1,230
1. The total person trips during the peak hour were estimated using existing student + staff population with a 10% absentee reduction for the AM and 90% arrival within the peak hour. The PM reflects 62% of AM people trips as per ITE Trip Generation Guide.								

Table 3: Existing People Trip Generation by Mode Share Based on First Principles

Travel Mode	Equivalent Mode Share	AM Peak (Person Trips/hr) 08:00-09:00			Equivalent Mode Share	PM Peak (Person Trips/hr) 15:00-16:00		
		In	Out <sup>2</sup>	Total		In <sup>2</sup>	Out	Total
Auto Driver (Primary)	7%	137	0	137	7%	0	90	90
Auto Passenger <sup>1</sup>	20%	391	0	391	9%	0	108	108
<i>From Primary Driver Trip</i>	2%	38	0	38	2%	0	25	25
<i>From Vehicle Drop-Off/Pick-Up</i>	18%	353	0	353	7%	0	83	83
Non-Auto Trips <sup>3</sup>	73%	1,457	0	1,457	84%	0	1,032	1,032
Total Person Trips	100%	1,985	0	1,985	100%	0	1,230	1,220
1. A factor of 1.28 was used for primary driver trips to account for typical North American occupancy rate based on ITE (i.e. 0.28 of primary driver trips are passengers carpooling). A factor of 1.5 was used for vehicle drop-off/pick-up to account for multi-passenger trips for families with more than one child (note that all drop-offs/pick-up assume at least 1 passenger being dropped off, so a rate of 1.5 was multiplied).								
2. Parents not staying on site (drop-off/pick-up) were not considered for people trips to the school.								
3. Based on rough estimates, approximately 55-65% of trips are transit/school bus, 2% cycling and 15-20% walking.								

The proposed development which currently has 36 temporary portables plans to add a new fixed building extension comprising of 25 new classrooms within a 2-storey addition (3,150 m<sup>2</sup>), maintain 12 existing portables, relocate 12 portables, and permanently remove 12 portables, for a net increase of 13 classroom spaces. Although it is forecasted that the student population will only rise from existing 2,300 students to approximately 2,400 students for the foreseeable future, a potential of up to 200 more students from existing (i.e. 2,500 students total) was considered as a worst-case scenario. Based on current student to staff ratios and estimates provided by OCDSB, an additional 15 staff are likely to be added to support the growing student population. **Table 4** and **Table 5** below uses the same assumptions as performed for existing conditions and mode shares derived from **Table 2** and **Table 3**, based on an additional 215 new total person trips (plus 10% absentee, 90% of all AM trips captured in single AM hour, 62% of person trips in PM compared to AM, etc).

Table 4: Net New Vehicle Trips with Future Expansion

Travel Mode	Equivalent Mode Share	AM Peak (Person Trips/hr) 08:00-09:00			Equivalent Mode Share	PM Peak (Person Trips/hr) 15:00-16:00		
		In	Out	Total		In	Out	Total
Vehicle Trips	19%	33	21	54	11%	4	12	16
<i>Primary Driver Trip</i>	7%	12	0	12	7%	0	8	8
<i>Vehicle Drop-Off/Pick-Up</i>	12%	21	21	42	4%	4	4	8
Total Person Trips <sup>1</sup>	100%			174	100%			108
1. The total person trips during the peak hour were estimated using the estimated net new student + staff population with a 10% absentee reduction for the AM and 90% arrival within the peak hour. The PM reflects 62% of AM people trips as per ITE Trip Generation Guide.								

Table 5: Net New Person Trips with Future Expansion

Travel Mode	Equivalent Mode Share	AM Peak (Person Trips/hr) 08:00-09:00			Equivalent Mode Share	PM Peak (Person Trips/hr) 15:00-16:00		
		In	Out <sup>2</sup>	Total		In <sup>2</sup>	Out	Total
Auto Driver (Primary)	7%	12	0	12	7%	0	8	8
Auto Passenger <sup>1</sup>	20%	34	0	34	9%	0	9	9
From Primary Driver Trip	2%	3	0	3	2%	0	2	2
From Vehicle Drop-Off/Pick-Up	18%	31	0	31	7%	0	7	7
Non-Auto Trips <sup>3</sup>	73%	128	0	128	84%	0	91	91
Total Person Trips	100%	174	0	174	100%	0	108	108
<ol style="list-style-type: none"> <li>1. A factor of 1.28 was used for primary driver trips to account for typical North American occupancy rate based on ITE (i.e. 0.28 of primary driver trips are passengers carpooling). A factor of 1.5 was used for vehicle drop-off/pick-up to account for multi-passenger trips for families with more than one child (note that all drop-offs/pick-up assume at least 1 passenger being dropped off, so a rate of 1.5 was multiplied).</li> <li>2. Parents not staying on site (drop-off/pick-up) were not considered for people trips to the school.</li> <li>3. Based on rough estimates, approximately 55-65% of trips are transit/school bus, 2% cycling and 15-20% walking.</li> </ol>								

As shown above in **Table 4** and **Table 5** the proposed school extension is anticipated to generate 175 to 110 additional person trips, 50 to 15 two-way vehicle trips and approximately 130 to 90 non-auto trips during the AM and PM peak hours respectively.

### 3.1.2. Trip Distribution and Assignment

Based on the location of adjacent arterial roadways, existing vehicle movements and boundary map for Earl of March Secondary School (bound by Huntmar Rd, Terry Fox, Herzberg Rd/Eagleson and Hazeldean), the distribution of site-generated traffic volumes was estimated as shown in **Figure 13**.

Figure 13: Site Generated Vehicle Traffic Percent Distribution



The anticipated 'new' auto trips for the proposed development from **Table 4** were then assigned to the road network with the distribution shown above in **Figure 14**, for the total net site-generated traffic.

Figure 14: Net New Site-Generated Traffic

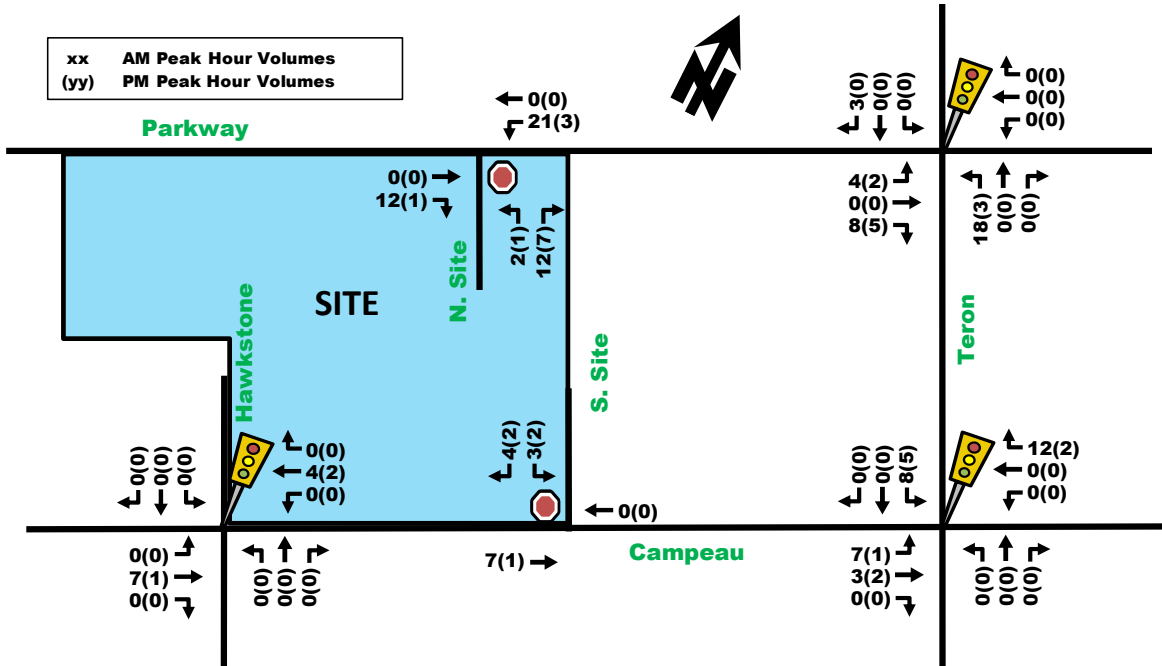

### 3.2. Background Network Traffic

#### 3.2.1. Transportation Network Plans

Refer to Section 2.1.3: Planned Conditions.

#### 3.2.2. Background Growth and Other Area Developments

Historic traffic counts at the intersection of Campeau/Teron were used to generate an annual growth rate for the study area. Counts from 2008, 2010 and 2024 were used. Table 6 below summarizes the observed growth rates for each approach for the AM, PM and 8h count history, with detailed counts provided in Appendix E.

Table 6: Historic Traffic Growth – Campeau/Teron

Time Period	Percent Annual Change				
	North Leg	South Leg	East Leg	West Leg	Overall
8 hrs	0.05%	0.96%	0.15%	-0.19%	<b>0.08%</b>
AM Peak	1.41%	5.27%	1.29%	1.54%	<b>1.68%</b>
PM Peak	-0.62%	1.32%	-0.66%	-0.89%	<b>-0.57%</b>

As shown in the table above, the overall 8h count shows negligible growth, while the AM peak hour shows a positive growth in the magnitude of 1% to 1.5% for the east, west and north legs (note that the south leg is an isolated development without room for future expansion unless intensified). The PM peak hour however shows a general negative growth rate ranging from -0.5% to -1%.

The neighbourhoods surrounding the school are generally mature and not expected to grow much over time, however areas much north of this development are ripe for future development, likelier to use larger arterials to move around such as March Rd and Terry Fox Dr. For the purpose of a more conservative analysis, a future growth rate of 1% annual during the AM peak hour will be used and 0% for the PM peak hour along arterial and major collector roads.



### 3.2.3. Future Background Volumes

As described in Section 2.1.3, there were no other area developments found within the vicinity of the site, but a 1% annual AM peak hour growth rate and 0% PM growth rate was deemed appropriate. The resultant background volumes have been provided in Figure 15.

Figure 15: Future Background Traffic Volumes (2030)

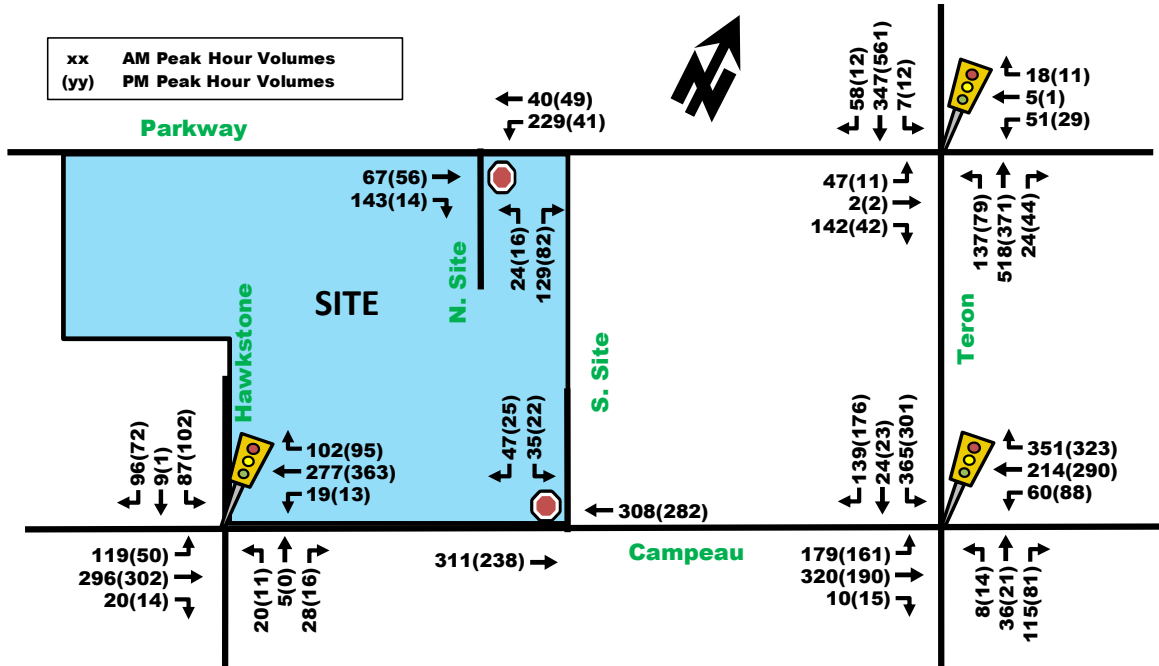

### 3.3. Demand Rationalization

This section is exempt as less than 75 vehicle trips are anticipated (refer to Section 3.1).

## 4.0 ANALYSIS

### 4.1. Development Design

#### 4.1.1. Design for Sustainable Modes

##### Pedestrian/Cycling Routes and Facilities

The site is generally well connected to the greater network for active transportation facilities. There are various multi-use pathways (MUPs) which are at least 3m wide or greater, including along the site frontage on Campeau Dr and on the north side of The Parkway connecting to The Parkway Access. There are also other pathways which are less than 3m wide (thus not considered MUPs) and a sidewalk network connecting to the site as shown in Figure 16.

As part of The Parkway access site modifications, such as the water and sewer hook-ups, the existing pathway connection to The Parkway Access' southeast quadrant would be impacted. The pathway will be reinstated as a 2.0m wide contemporary pathway. This reinstated pathway will then cross The Parkway Access following SC7.1 specifications with a depressed curb across the access, no TWSIs and a continuous asphalt surface.

Figure 16: Existing and Future Active Transportation Facilities External to the Site



Once within the site, the proposal would provide a new active transportation connectivity from the MUP north of The Parkway and the reinstated pathway facility east of the Parkway Access directly to the front entrance of the school. The internal active transportation facilities from The Parkway are proposed at least 4.3m wide, with the intention to provide a direct line of path from the MUP to the front entrance while also providing space for a landing pad for those being dropped off or picked up by public transportation. The first bus layby has been proposed with an open exit (missing a bulbout curb on departure) to improve bus circulation, fit an articulated bus and make the buses stack up closer to the curb. A “No Stopping” sign and road paint has been recommended for the last 5m approaching the new drive-aisle headed to the fire lane to prevent buses from blocking sight lines of the north-south crosswalk (refer to orange hatch in **Figure 17**). A large courtyard is proposed on the north side of the extension which will add four new exterior bike racks.

Approaching from the south (Campeau Dr), the existing active transportation facilities will be maintained which includes a plethora of pathways intertwined by planters and landscaping. The internal active transportation facilities and location for bike parking racks have been illustrated in **Figure 17**. Some areas between the portables have not been illustrated as pedestrian facilities, though it’s noteworthy that the fire lane is paved and does not allow through traffic, making it a good candidate for pedestrian activity. It is standard that the surface between portables would be paved and winter maintained.

Figure 17: Future and Existing Active Transportation Facilities Internal to the Site

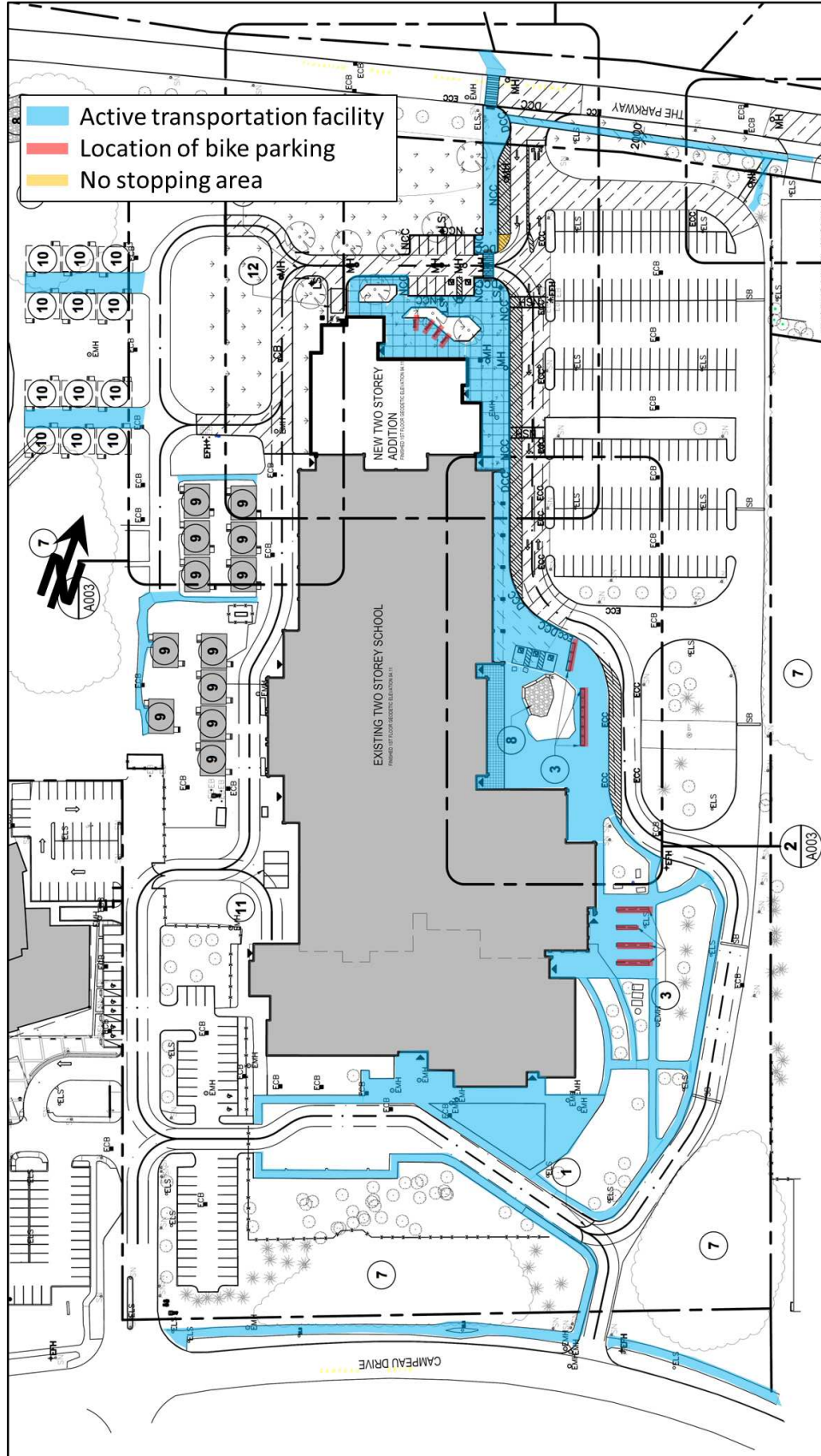

### **Location of Transit Facilities**

While transit stops exist on Teron Rd and Campeau Rd, both within 500m walk or less to the school front doors, it was observed during an on-site inspection on June 21, 2024, that the majority of students arrive or depart the site using the 600 series OC Transpo “Special School Routes” or bus route #161 and #168 which operate internal to the site during bell hours. These buses pick-up and drop-off students adjacent to the front door of the school, minimizing walking distances.

### **Parent Pick-Up/Drop-Off**

Parent pick-up and drop-off was observed to occur mainly near the north-east quadrant of the site, with various parents parking temporarily to let children in/out of their vehicle. Due to the high transit usage and quantity of buses required to serve the students, plus the limited space available to accommodate all buses, it is recommended that parent pick-up/drop-off continue to occur as existing conditions, away from the bus laybys.

#### **4.1.2. Circulation and Access**

A site observation was undertaken to review existing internal site traffic patterns during school start and end times. Overall, it was observed that most of the activity in the morning and afternoon site peak hour occurred in the 10-20 minutes leading up to the starting bell and 10-20 minutes after the dismissal bell, with very little activity outside of that time period. Within that time period, 11 buses were observed, comprising of 7 articulated OC Transpo buses, 3 short OC Transpo buses and 1 traditional yellow school bus. OC Transpo bus routes were generally duplicated, with one bus actively loading until it becomes full, while the other waits until the loading bus is full to start its loading process. This allowed the full bus to depart from the site and a new bus take its place to continue loading students. At no time were all 11 buses present at the site during a single moment. **Figure 18** shows buses queueing waiting for the dismissal bell.

Figure 18: Buses Queueing Internal to Site During Afternoon Peak Hour



Additionally, it was noted that all buses entered performing a westbound left-turn into the site from The Parkway, with all articulated buses and 1 short bus leaving the site using the outside perimeter of the parking lot travelling northbound and exiting back on to The Parkway performing a U-turn like maneuver as shown in **Figure 19**. Note that while it is generally preferred that buses approach an intersection at a 90-degree angle, the 180-degree turn was deemed acceptable given that the egress is stop controlled requiring bus drivers to stop and inspect their surroundings before proceeding. This method also keeps buses along the periphery of the parking lot, reducing conflict with pedestrians headed to/from their vehicles/parent pick-up/drop-off internal to the site.

Figure 19: Observed Bus Circulation – Earl of March

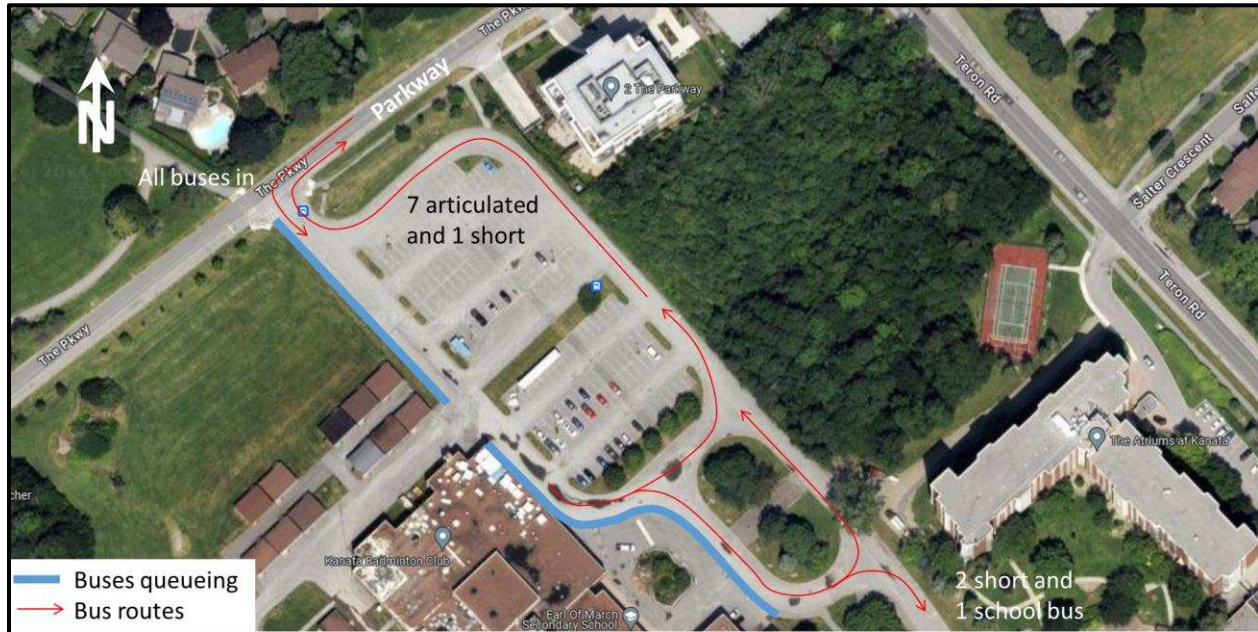

The proposed bus loading bays have been designed to accommodate a mixture of bus types. Based on the amount of loading bay space provided, up to 7 articulated buses may be parked on active loading bays at a single point in time without obstructing travel lanes. The latest site plan from November 6, 2024 proposes an additional 4 layby spaces for buses waiting for an opening at the active loading bays, located along the perimeter of the small circulating island as shown in **Figure 20**. As a bus becomes full, it can exit the site for a new bus to replace its spot. During the morning hours, buses will arrive, alight their passengers and depart from the site, leaving space for new buses to arrive and use the loading bays. In the afternoon hours, the new site circulation allows for 7 active loading buses and 4 buses to wait for an active loading bay to open up.

The existing circulating island is proposed as one-way bus-only travel in counterclockwise direction for three quarters of the circle, with the north segment proposed as clockwise direction only. The bus loading bays are proposed at 3.5m wide. Adjacent to the loading bays, a 3.5m southbound travel lane is proposed which would be used by buses travelling to complete their loop, while the northbound travel lane is proposed at 3.0m wide and is intended to be used by private vehicles only (not a proposed bus travel lane).

The loading bay and fire route proposed on the west side of the school have been checked and verified to accommodate the appropriate design vehicles. Turning templates have been provided in **Appendix F**. The loop around the portable units is proposed as a fire route only access and will be gate controlled to dissuade regular vehicles from using the loop.

Speed humps have been proposed at two locations to encourage traffic calming and reduced speeds near the bus loading bays, vehicle parking and the front entrance of the school.

Figure 20: Bus Layby Locations and Proposed Bus Circulation

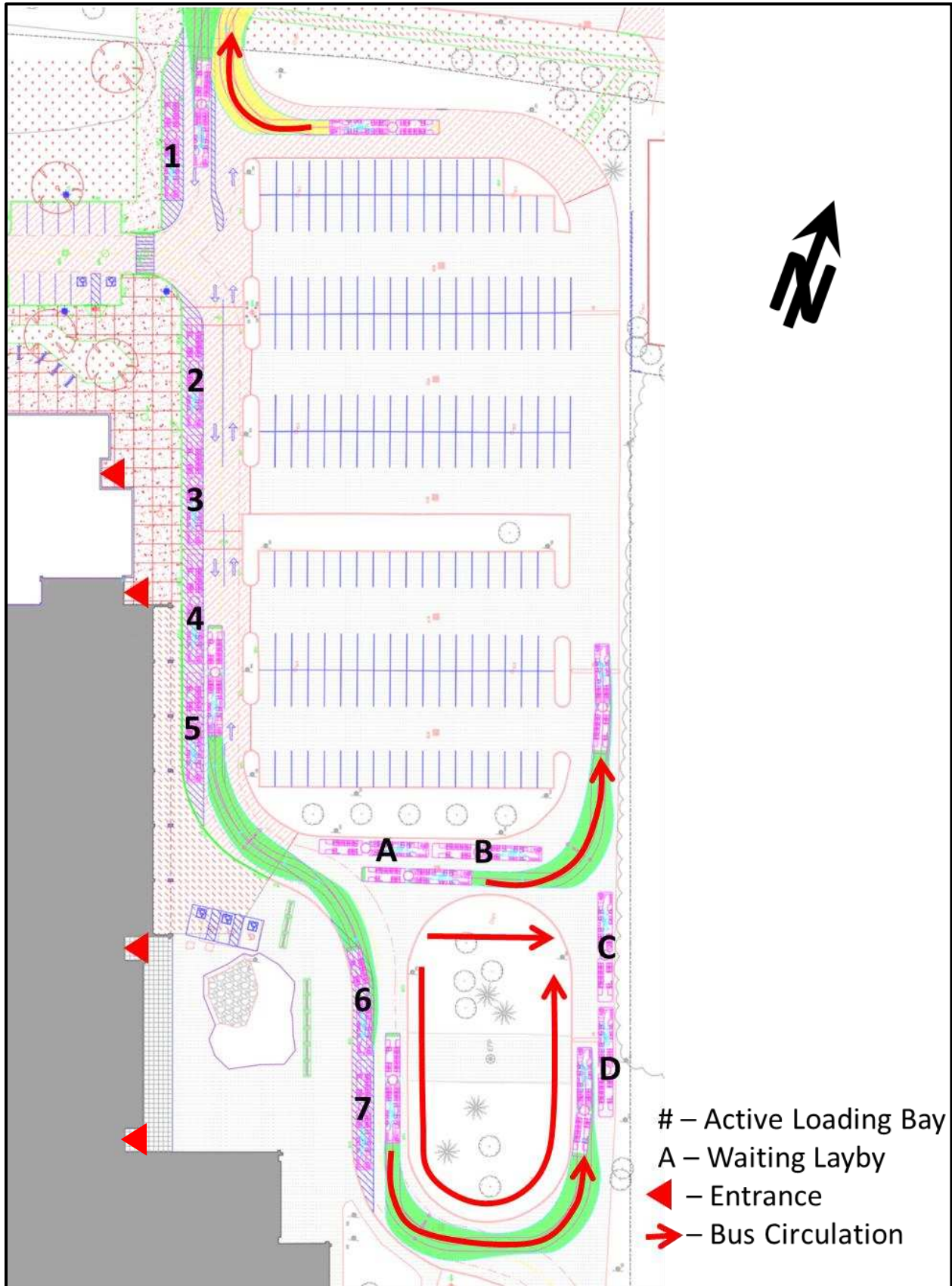

### 4.1.3. New Streets Network

Exempt, only required for Plans of Subdivision.

## 4.2. Parking

The following parking analysis reflects the minimum number of parking rates and spaces required based on the City of Ottawa Zoning By-Law for developments located in Area C on Schedule 1A. **Table 7** summarizes the minimum vehicle and bicycle parking rates from Part 4, Parking, Queueing and Loading Provisions parking by-law, referenced from Tables 101, 102, and 111A.

Table 7: Required Vehicle and Bicycle Parking Spaces

Land Use	Number of Classrooms	Vehicle Parking Rates	Vehicle Spaces		Bicycles		
		Base Rate	Min Required Spaces	Proposed Spaces	Base Rate	Min Required	Proposed Spaces
Secondary School (N80)	99	2/Class	198	242	1 per 100m <sup>2</sup>	163 <sup>1</sup>	213
Elementary School (N81)	24	1.5/Class	36				
<b>Total</b>			<b>234</b>				

<sup>1</sup> - total site GFA proposed at 16,243 squared meters.

As shown above in **Table 7**, the site is providing slightly above minimum required vehicle parking and exceeding minimum bike parking requirements by approximately 30%. Bike parking is proposed outdoors in bike parking racks.

There are a total of 7 accessible spaces on site. Three existing accessible parking stalls are located in front of the main doors. Two other existing accessible stalls are located in the lot accessible from Campeau Drive. The new parking lot fronting the proposed extension would provide an additional two accessible spaces.

### 4.3. Boundary Street Design

Multi-Modal Level of Service (MMLOS) analysis was conducted for the site frontages, The Parkway and Campeau Dr, based on the City of Ottawa's MMLOS Analysis Guidelines. Note that a revised MMLOS is currently being developed, however it has not been adopted yet by the City of Ottawa at the time this report was prepared.

Campeau Dr is an arterial road that consists of the following features within the study area:

- Generally, 3-vehicle travel lanes fronting the site.
- A 3.0m wide MUP on north side of road and 1.8 to 2m wide pathway on south side of road, both separated by more than 2m wide boulevard.
- More than 3,000 average daily curb lane traffic.
- Classified as a spine bike route and cross-town bikeway.
- Transit routes operate on segment, not part of transit priority corridor.
- Not a truck route.
- Posted speed limit of 60km/h.
- Approximately 3.25m wide lane at narrowest pinch point.

The Parkway is a collector road that consists of the following features within the study area:

- 2-vehicle travel lanes.
- 3m MUP with more than 2m boulevard on northwest side of Parkway Access, no facilities on southwest side. No facilities on northeast side of Parkway Access, existing 1.2m wide pathway on southeast side which is proposed to be reinstated as a 2m pathway with more than 2m boulevard.
- More than 3,000 average daily curb lane traffic.
- Not a spine bike route.

- Transit routes operate on segment, not part of transit priority corridor.
- Not a truck route.
- Posted speed limit of 40km/h.
- Approximately 3.5m wide lane.

The multi-modal level of service analysis for adjacent site roadways is summarized in **Table 8**, with detailed analysis provided in **Appendix G**. The table also identifies the target LOS, based on the land-use designation and road classification of the development site and the boundary streets. The land-use designation used for this development is “within 300m of a school”. The road classifications of each of the boundary streets were noted in the descriptions of features above.

Table 8: MMLoS - Boundary Road Analysis

Road Segment	Multi-Modal Level of Service							
	Pedestrian		Bicycle		Transit		Truck	
	PLoS	Target	BLoS	Target	TLoS	Target	TkLoS	Target
Campeau – North Side (existing/future)	D	A	A	A	D	N/A	D	E
Campeau – South Side (existing/future)	E	A	A	A	D	N/A	D	E
Parkway – N, W of access (existing/future)	B	A	A	D	D	N/A	-	N/A
Parkway – S, E of access (existing only)	F	A	D	D	D	N/A	-	N/A
Parkway – Remainder (existing/future)	F	A	D	D	D	N/A	-	N/A
Parkway – S, E of access (Future only)	B	A	D	D	D	N/A	-	N/A
1. Locations referenced for The Parkway are relative to the Parkway Access. 2. Where a bi-directional MUP is provided, both sides of the road will be considered as having that one facility (mobility east-west provided on single side).								

### Pedestrian

- Neither future nor existing PLoS targets were met given the posted operating speeds. Reducing speeds to 30km/h and providing at least 2m sidewalks/pathways with 2m separation from motor vehicles would result in the desired PLoS of ‘A’, however speeds of 30km/h are inappropriate for arterial roads such as Campeau Dr. Although The Parkway is a collector road, its main function is serving the local community and does not provide significant connectivity to the global network. An opportunity to reduce the posted speed to 30km/h during school hours could be appropriate, but it would not improve PLoS for the south side west of access or north side east of access as there are no sidewalk facilities proposed in that area.

### Bicycle

- The BLoS targets were met at all locations for existing and future conditions.

### Transit

- There are no TLoS targets since none of the segments belong to a higher order transit priority corridor.

### Truck

- There are no truck TkLoS targets on The Parkway. Campeau Dr generally has travel lanes greater than 3.7m wide, but at the tightest pinch points, was measured at 3.3m which meets the desired target.



## 4.4. Access Intersection Design

---

Note, former sections 4.4.2 (Access Control) and 4.4.3 (Access Design) have been moved to Section 4.9.1 and 4.9.2 as per the revised TIA Guidelines, June 2023.

### 4.4.1. Location and Design of Access

#### Vehicle Access and Circulation

The site currently has two accesses which will remain in their current location, with no new accesses proposed. The Campeau Dr access is currently an outbound access from the site only. No changes are proposed to the existing Campeau Access.

The client proposes narrowing the Parkway Access from existing 12.5m wide to 10.0m wide to provide traffic calming, shorten the pedestrian crossing distance and prioritize active transportation. Based on a review of turning movements, the 10.0m wide access was found to be required to facilitate articulated bus travel to and from The Parkway. In order to accommodate the existing bus turning manouvers, a wide 4.7m receiving lane and a 4.7m departure lane with a 0.6m centerline painted gore has been proposed.

The bus turning movements at the Parkway Access using this proposed layout have been illustrated in **Figure 21** with higher quality detailed turning movements provided in **Appendix F. Figure 22** illustrates the proposed lane arrangements and geometry for The Parkway Access. It should be noted that minor overlap may occur on The Parkway if an exiting bus is confronted with an inbound bus. The overlap does not occur internal to the site, which allows a safe location for the outbound bus to wait and yield for the inbound bus to enter the site. Increasing the radii or the access width would resolve this conflict but would have a negative effect on active transportation. The proposed design is based on a balanced approach between smooth circulation and priority to active transportation modes. Lastly, it should be noted that the software used to simulate these turns is generally considered more conservative than real-life operations, and an overlap may not actually happen in real life.

Figure 21: Articulated Bus Turning In and Out of the Site

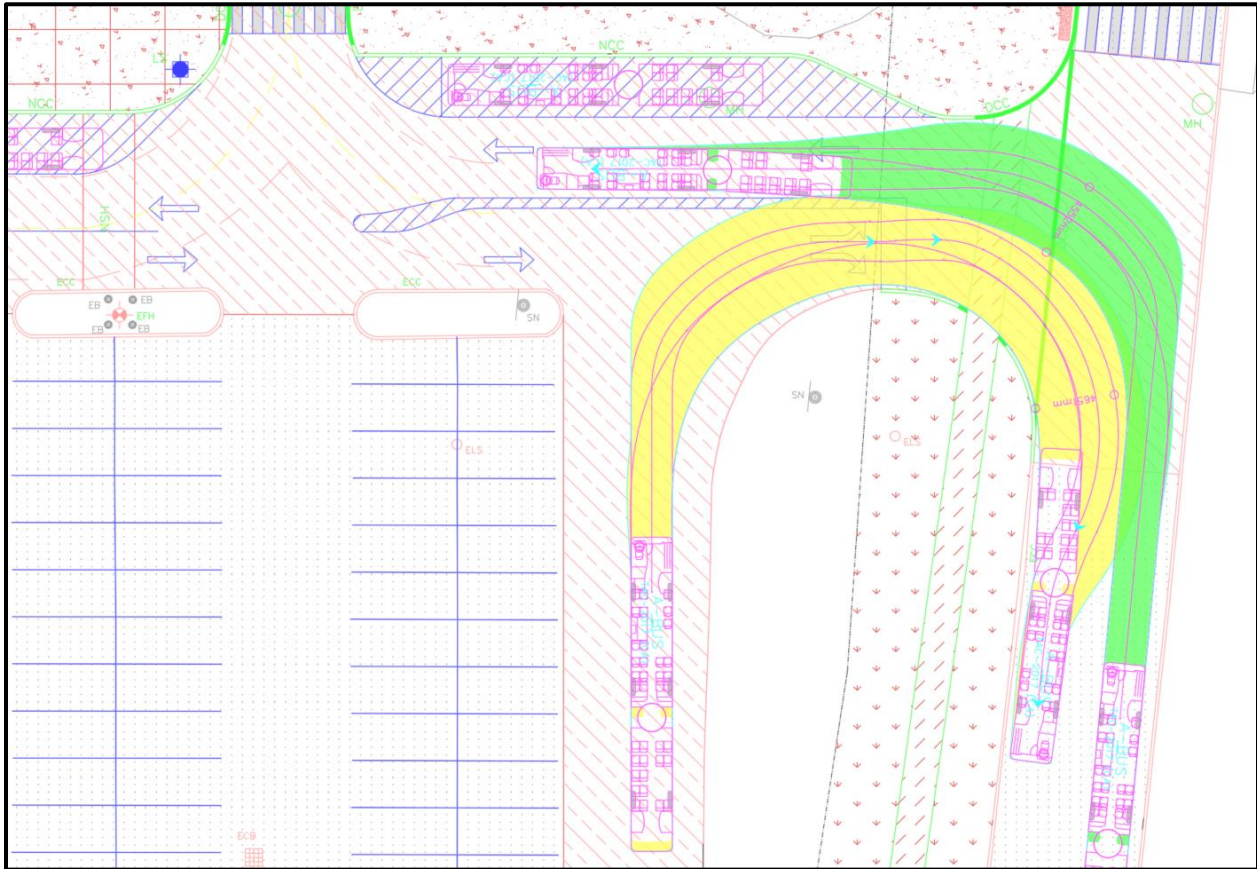

*Note that non-articulated buses require a smaller footprint to perform their turning manoeuvres.*

### Throat Length

The Transportation Association of Canada (TAC) Geometric Design Guide for Canadian Roads, Chapter 8 (Access) provides guidelines for clear throat length. Clear throat lengths are only recommended for arterial and collector roads. There is no specific guidance for schools, however a basic risk assessment of potential internal blockage which would cause spillback on to The Parkway was considered. In general, all land uses suggest between 8m up to 40m clear throat lengths for developments accessed from a collector road. The distance from The Parkway Access to the first major conflict, considered the T-split headed to additional parking and fire route to the west, is located approximately 35m, providing sufficient separation from The Parkway Access and considered low risk. Note that the clear throat length is sensitive to inbound vehicles only, and the first bus layby was not considered as buses will skip it if occupied by another bus, or would enter it unimpeded if the bay is open, reducing the chances of creating a back-up near the access entrance. The proposed design has storage space for at least 2 vehicles before spilling on to The Parkway. Should a longer queue form, it is expected to be of short duration and only for a short period of time twice a day (before the start of school bell and after the dismissal bell). Based on historic counts, The Parkway has less than 2,000 vehicles per day which would see minimal impacts should the rare queue spill beyond the site access.

Figure 22 illustrates lane arrangements and clear throat length at The Parkway Access.

Figure 22: The Parkway Access – Lane Arrangements and Geometry

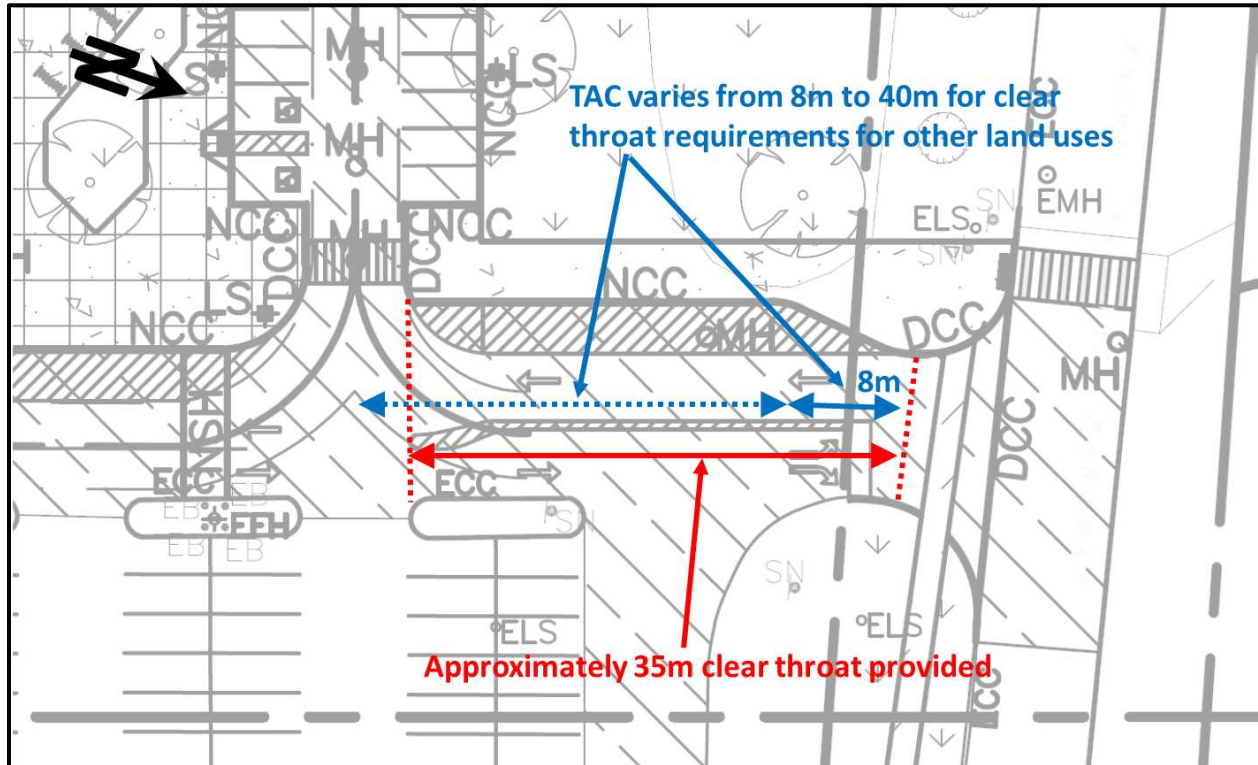

### Private Approach By-law

Additionally, the Private Approach By-Law requirements for the City of Ottawa were reviewed, with the following observations:

- The site has two frontages (approximately 185m and 400m long) which permits having at least two two-way private approach per frontage.
- As required by part m section ii, the minimum distance between the proposed access and the nearest adjacent intersecting street line is 45m for accesses on major collector or arterial roads. The nearest adjacent intersecting street to the Campeau Access is Hawkestone Gate which is located approximately 130m away and thus meets the requirements.
- The distance between the proposed accesses and the adjacent property lines meets the required 3m separation.
- The private approach on The Parkway exceeds 9m in width which is not in compliance with Section 25(c), but it was deemed acceptable given the bus turning requirements.
- The grade of the private approach is to not exceed 2% within the private property for a distance of 9.0m to the curb line. No major grades are proposed within the site.

The access designs are in conformance with the City of Ottawa Private Approach By-law 2003-447. The accesses are to be constructed as per City of Ottawa Standard Detail SC7.1.

## 4.5. Transportation Demand Management

### 4.5.1. Context for TDM

Based on the type of development, it is assumed that most trips generated by the proposed site will be students and staff entering the site in the AM peak hour and existing the proposed site in the PM peak hour to return home. Sections 3.1.1 and 3.1.2 describe how many trips are anticipated per travel mode.

#### 4.5.2. TDM Program

The TDM infrastructure checklist and TDM Measures are attached as **Appendix H**.

##### TDM Supportive Development Design and Infrastructure Checklist (Non-Residential):

- Ten (10) out of the ten (10) “required” measures have been satisfied.
- At least eleven (11) of sixteen (16) “basic” measures related to walking, cycling, transit and parking have been satisfied or are not applicable.
- Four (4) of the of the eleven (11) candidate “better” measures are also proposed or are non-applicable.

##### TDM Measures Checklist (Non-Residential):

- Six (6) out of ten (10) “basic” measures related to walking, cycling, transit, parking and TDM marketing have been satisfied or are not applicable. Two (2) of those, which have been designated by an asterisk (\*), are considered by the TDM Measures to be some of the most dependably effective tools to encourage sustainable travel modes. This includes:
  - Display walking and cycling information at major entrances.
  - Display transit information at major entrances.
  - Provide links to OC Transpo information.
  - \*Designate an internal coordinator or contract with external coordinator
  - \* Provide multi-modal travel information package to new staff.
- Eight (8) out of twenty-six (26) “better” measures related to walking, cycling, transit, parking and TDM marketing have been satisfied. Of note, this includes:
  - Students receive fully subsidized transit passes.

#### 4.5.3. Need and Opportunity

Given the concentrated arrival and departure times before and after the school bell, the site is a great candidate for transit-oriented transportation. The school board (OCDSB) provides public transit passes to all students, which provides a large incentive for students to travel to and from the school for free. The site is well accessible via active transportation facilities and is a recommended mode of transportation for those who live near the school or along the existing facilities. The site proposes additional bike parking racks for those who wish to bike and proposes traffic calming measures such as speed humps and a reduced access width to promote safety for active users.

#### 4.6. Neighbourhood Traffic Management

---

This section is exempt as it does not meet all criteria outlined in the June 14, 2023 TIA Guideline revision and is therefore exempt.

#### 4.7. Transit

---

##### 4.7.1. Route Capacity

A site inspection was performed in June 2024 to understand bus circulation and general existing bus operations. As summarized previously in **Section 4.1.2** and **4.4**, it was observed that buses normally enter the site in the morning, alight passengers and depart from the site. During the afternoon class dismissal period, some buses arrive a few minutes early and queue within the layby areas. Once classes finish, the first bus on the row for each bus route is loaded first, and once full, they depart and make room for newly arriving buses. During the observation, 11 buses was sufficient to meet the transit demands. As the school expands, OC Transpo may be required to provide additional buses to satisfy growing transit demands, but is anticipated to be likely up to one extra bus based on trip generation and potential other buses not filling up entirely. The proposed development extension can accommodate up to 7 articulated buses within the layby lanes, without blocking any travel lanes. As those buses fill up, new ones can take their place. Should more than 7 buses

arrive on site at a given time, the excess newly arrived buses can wait at 4 additional waiting laybys proposed around the small circulating island. While waiting, other buses can circulate around them as they exit, and once a new spot becomes available, these waiting buses can circulate around the school perimeter and enter an unoccupied active loading layby.

Based on the trip generation **Table 5**, at most 90-to-130 new non-auto person trips are anticipated to be generated during the AM and PM peak hour respectively. Of these trips, only a portion of them is expected to take transit, while others may walk or bike. Based on OC Transpo's bus fleet, it is anticipated that a single articulated bus could accommodate the added student population; however, it may be possible that the existing buses could absorb the increased student population if they are not currently operating at capacity.

#### **4.7.2. Transit Priority**

Based on the TIA Guidelines Update, June 2023, this section is exempt as less than 75 vehicle trips are forecasted.

### **4.8. Review of Network Concept**

---

Based on the TIA Guidelines Update, June 2023, this section is exempt as less than 200 new person trips above existing zoning are forecasted.

### **4.9. Intersection Design**

---

This section is exempt as the development is forecasted to generate less than 75 auto trips and therefore does not trigger the need for this section as outlined in the June 14, 2023 TIA Guideline revision.

## **5.0 FINDINGS, CONCLUSIONS AND RECOMMENDATIONS**

Based on the results summarized herein the following findings and recommendations are provided:

### **Existing Conditions**

- OCDSB school board is proposing an extension to the Earl of March Secondary School in Kanata which has a current population around 2,300 students.
- The site is served by predominantly OC Transpo buses which drop-off and pick-up students adjacent to the front door of the school. Site observations confirmed approximately 10-15 buses operate within the site during bell hours.
- The site is well served by pedestrian and cycling infrastructure near the site.

### **Proposed Development**

- The new extension plans to replace approximately 12 temporary portable structures with a fixed building extension comprising of 25 new classrooms within a 2-storey addition (3,150 m<sup>2</sup>). As part of the school extension, 12 existing portables will be relocated west of the extension.
- A custom trip generation and custom mode shares were developed based on first principles, using the known student and staff population and vehicle counts captured during the peak hours of the school. Using these assumptions, it was forecasted approximately 10 'new' two-way vehicle trips, 35 to 10 'new' two-way passenger trips (including parent pick-up/drop-off), and 130 to 90 'new' two-way active transportation trips including transit, walking and cycling.
- The site meets the parking bylaw requirements, providing slightly above minimum required vehicle parking and exceeding minimum bike parking requirements by approximately 30%.
- The site will maintain its two existing accesses:
  - The Campeau Access will remain as is, operating as an egress from the site only.
  - The Parkway Access is proposed to be re-configured with a narrowing (12.5m to 10m wide) and improvements according to SC7.1. The narrowing intends to serve as a traffic calming method, to

shorten the pedestrian crossing distance and prioritize active transportation. Bus turning movements were reviewed and no concerns were identified.

- Bus circulation was reviewed based on site observations. The current route loop that OC Transpo was observed to be using was considered acceptable for this site. The future extension proposes an improved layby bay for buses which can fit up to 7 articulated buses (or a variation of different bus sizes and types).
  - In the morning, buses arrive, offload students and depart the site once empty, allowing room for newly arrived buses to offload students near the front door.
  - In the afternoon, buses will have space to layby while students load. Once a bus is full, they can depart the site and provide room for a new bus to begin loading. If the layby bays become fully occupied by queueing buses, then additional space is available on 4 reserved waiting bays along the small circulating island which is proposed for buses only and with a one-way traffic only circulation.
- The site provides notable TDM measures and infrastructure for a school. Specifically, the site provides all students with OC Transpo passes to encourage them arriving by bus.

### **Future Conditions**

- Other area developments were acknowledged within this report.
- The MMLoS road segment analysis showed that none of PLOS targets were met. Reducing speeds to 30km/h and providing at least 2m sidewalks/pathways with 2m separation from motor vehicles would result in the desired PLOS of 'A'. The BLOS targets were met at all locations. There are no transit or truck target level of service since the adjacent roads are not part of transit priority routes or truck routes. Campeau Dr meets the truck level of service.
- The MMLoS intersection (for signalized intersections only) analysis showed that PLOS targets were not met given the number of lanes required to cross. BLOS targets were only met at Teron/Parkway. Intersections involving Campeau Dr have a higher target rate given the crosstown bikeway designation and would require cycling infrastructure through the intersections to meet the desired targets. There are no transit or truck target level of service since they adjacent roads are not part of transit priority routes or truck routes.
- Given the low number of vehicle trips forecasted (less than 75), no major impacts to the study area network are anticipated. Future conditions are forecasted to operate similarly to today.
- New and improved active transportation connections to The Parkway are proposed which would lead to the new front entrance of the school. Traffic calming measures as well as a narrower vehicle access is proposed to prioritize active users.

Based on the preceding report, the proposed school extension for Earl of March Secondary School is recommended from a transportation perspective.

Prepared By:



Juan Lavin, P. Eng.  
Transportation Engineer

Reviewed By:



Jake Berube, P.Eng. RSP<sub>1</sub>  
Transportation Engineer

# Appendix A:

TIA Screening Form

City of Ottawa 2017 TIA Guidelines (2023 Revisions)

Date 2024.04.12

Earl of March Secondary School

**TIA Screening Form**

Project Addition

Project Number 910537-10013

Results of Screening	Yes/No
Development Satisfies the Trip Generation Trigger	Yes
Development Satisfies the Location Trigger	No
Development Satisfies the Safety Trigger	No

Module 1.1 - Description of Proposed Development	
Municipal Address	4 The Pkwy, Kanata, ON K2K 1Y4
Description of location	Located north of Hwy 417 and Campeau Drive, east of fTeron Road and south of The Parkway.
Land Use	Secondary School
Development Size	New Addition: +3,185sq.m. (25 new classrooms) No proposed changes to accesses
Number of Accesses and Locations	Existing: Two-Way Access to The Parkway. Shared access via the north leg of Campeau/Hawkstone Gate. One-way egress to Campeau Drive. Partial access to
Development Phasing	Single Phase
Buildout Year	2027 (Estimated)
Sketch Plan / Site Plan	See Attached

Module 1.2 - Trip Generation Trigger		
Land Use Type	High School	
Development Size	625	Students
Trip Generation Trigger Met?	Yes	

Module 1.3 - Location Triggers	
Development Proposes a new driveway to a boundary street that is designated as part of the City's Transit Priority, Rapid Transit, or Spine Bicycle Networks (See Sheet 3)	No
Development is in a Design Priority Area (DPA) or Transit-oriented Development (TOD) zone. (See Sheet 3)	No
Location Trigger Met?	No

Module 1.4 - Safety Triggers		
Posted Speed Limit on any boundary road	<80	km/h
Horizontal / Vertical Curvature on a boundary street limits sight lines at a proposed driveway	No	
A proposed driveway is within the area of influence of an adjacent traffic signal or roundabout (i.e. within 300 m of intersection in rural conditions, or within 150 m of intersection in urban/ suburban conditions) or within auxiliary lanes of an intersection;	No	
A proposed driveway makes use of an existing median break that serves an existing site	No	
There is a documented history of traffic operations or safety concerns on the boundary streets within 500 m of the development	No	
The development includes a drive-thru facility	No	
Safety Trigger Met?	No	



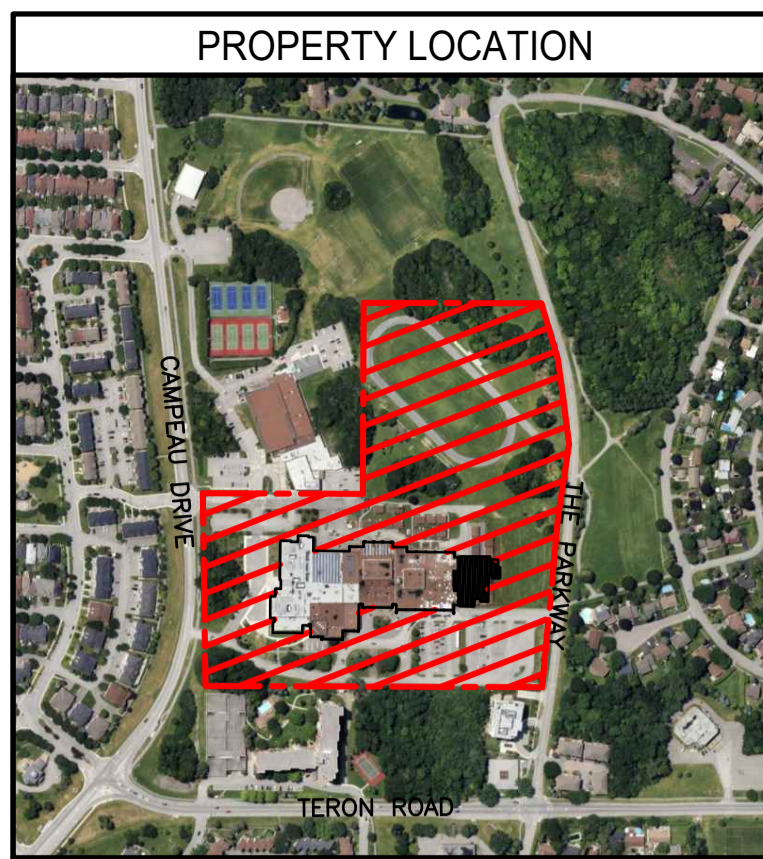

**LEGAL DESCRIPTION OF PROPERTY**  
 PART OF LOT 3  
 CONCESSION 3  
 GEOGRAPHIC TOWNSHIP OF MARCH  
 CITY OF OTTAWA

**SITE DATA**

LOT AREA	97419 M SQ
EXISTING BUILDING AREA	13070 M SQ
ADDITION BUILDING AREA	1579 M SQ
TOTAL BUILDING AREA	14649 M SQ
LOT COVERAGE	15%

**PARKING CALCULATIONS**

MINIMUM PARKING REQUIREMENTS:  
 SECONDARY SCHOOL: 2 SPACES PER CLASSROOM  
 ELEMENTARY SCHOOL: 1.5 SPACES PER CLASSROOM

REQUIRED USE	No. CLASSES	SPACES PER CLASS	SPACES REQ'D
EXISTING HIGH SCHOOL	50	2.0 / CLASS	100
EXISTING ELEMENTARY	24	1.5 / CLASS	36
EXISTING PORTABLES	12	2.0 / CLASS	24
NEW SCHOOL ADDITION	25	2.0 / CLASS	50
FUTURE PORTABLES	12	2.0 / CLASS	24
<b>TOTAL REQUIRED PARKING SPACES</b>			<b>234</b>
TOTAL REQUIRED PARKING SPACES FOR THE PHYSICALLY DISABLED			7

**PROVIDED**

EXISTING REGULAR	227
EXISTING BARRIER FREE	5
NEW REGULAR @ 5.2mD X 2.6mW	11
NEW BARRIER FREE @ 5.2mD X 3.66mW	2
<b>TOTAL SPACES PROVIDED</b>	<b>245</b>

**BICYCLE PARKING CALCULATIONS**

RATIO	1 PER 100m <sup>2</sup> OF GROSS FLOOR AREA
EXISTING BUILDING GROSS FL. AREA	13430.0 M SQ
NEW ADDITION GROSS FL. AREA	1973.0 M SQ
PORTABLE GROSS FL. AREA	840.0 M SQ
FUTURE GROSS FL. AREA	840.0 M SQ
TOTAL GROSS FLOOR AREA	17083.0 M SQ
TOTAL REQUIRED PARKING	171 PARKING SPOTS
NEW BICYCLE PARKING	36 PARKING SPOTS
EXISTING BICYCLE PARKING	180 PARKING SPOTS
TOTAL PROVIDED PARKING	216 PARKING SPOTS

**CITY OF OTTAWA ZONING**

REQUIRED	PROVIDED
MINOR INSTITUTIONAL ZONE: I1A	
LOT AREA	MIN. 400m <sup>2</sup> 97,419 SQ M
LOT WIDTH	MIN. 15.0m 374.3 M
BUILDING HEIGHT	MAX. 15.0m 9.5 M
FRONT YARD SETBACK	MIN. 7.5 M 51.5 M
REAR YARD SETBACK	MIN. 7.5 M 64.7 M
SIDE YARD SETBACK	MIN. 7.5 M 36.5 M
LANDSCAPE @ PARKING	MIN. 15% 20%

**GENERAL NOTES**

- FOR SCHOOL SITE GRADING INFORMATION REFER TO SITE GRADING DRAWING AS PREPARED BY CIVIL ENGINEER.
- FOR SOIL INVESTIGATION REPORT REFER TO GEOTECHNICAL REPORT.
- ALL WORK OUTSIDE PROPERTY LINE TO BE CONSTRUCTED TO LOCAL MUNICIPALITY CONSTRUCTION STANDARDS.
- RE-SOD ALL LANDSCAPING AREAS DISTURBED BY NEW CONSTRUCTION.
- FOR SCHOOL SITE SERVICES REFER TO SITE SERVICE DRAWING PREPARED BY CIVIL ENGINEER.
- CONTRACTOR TO VERIFY ALL DIMENSIONS ON SITE AND REPORT ANY ERRORS TO THE ARCHITECT.
- CONTRACTOR TO CO-ORDINATE WITH ALL DRAWINGS.
- FOR LANDSCAPING DESIGN REFER TO LANDSCAPING PLAN PREPARED BY LANDSCAPE ARCHITECT.
- COORDINATE AND OBTAIN REQUIRED PERMITS FROM OTTAWA-MACDONALD CARTIER INTERNATIONAL AIRPORT AZR IN CONNECTION WITH THE ERECTION OF CONSTRUCTION EQUIPMENT SUCH AS BUT NOT LIMITED TO CONSTRUCTION CRANES.
- NEW PARKING STALL SIZE: 2600mm x 5200mm
- SLOPES OF CONCRETE/PAVING AT DEPRESSED CURBS SHALL NOT EXCEED 5%
- FOR SITE SURVEY INFORMATION, SEE TOPOGRAPHIC SURVEY DRAWING PREPARED BY FARLEY, SMITH & DENIS SURVEYING LTD.

**DRAWING LEGEND**

- BARRIER FREE PARKING
- BUILDING ENTRANCE/EXIT
- EXISTING BUILDING
- EXISTING INTERLOCK PAVERS
- EXISTING ASPHALT PAVING
- EXISTING CONCRETE WALKWAY
- NEW SOD AND TOPSOIL (REFER ALSO TO LANDSCAPE PLAN)
- NEW CONCRETE WALKWAY WITH CONTROL JOINTS
- NEW TYPE 1 ASPHALT - HEAVY DUTY (REFER TO SPEC.)
- NEW TYPE 2 ASPHALT - MEDIUM DUTY (REFER TO SPEC.)
- EXISTING SPEED BUMPS TO REMAIN
- EXISTING SIGN
- EXISTING BOLLARD
- EXISTING CONCRETE CURB TO REMAIN
- EXISTING DEPRESSED CONCRETE CURBS
- EXISTING FIRE HYDRANT
- NEW SPEED HUMPS
- NEW PAINTED PEDESTRIAN CROSSING
- NEW 'FIRE ROUTE' SIGN
- NEW 'NO ENTRY BUS ONLY' SIGN
- NEW BOLLARD
- NEW CONCRETE CURB
- NEW DEPRESSED CONCRETE CURB
- NEW BICYCLE RACK
- EXISTING FLAG POLE
- EXISTING CATCH BASIN
- EXISTING UTILITY POLE
- EXISTING LIGHT STANDARD
- NEW PARKING LOT LIGHT STANDARD (REFER TO ELECTRICAL)
- EXISTING GOAL POST
- EXISTING MAN HOLE
- NEW MAN HOLE. REFER TO CIVIL
- NEW CATCH BASIN. REFER TO CIVIL
- EXISTING FENCE
- PROPERTY LOT LINE
- PROPERTY SETBACK LINES
- FIRE ROUTE
- EXISTING TREE TO REMAIN, REFER TO LANDSCAPE DOCUMENTS
- EXISTING PORTABLE CLASSROOM
- FUTURE PORTABLE CLASSROOM
- NEW TREES - SEE LANDSCAPE DRAWINGS.

**DRAWING NOTES**

- NEW GATE. REFER TO A004
- EXISTING GATE.
- EXISTING BICYCLE RACK.
- NEW BICYCLE RACK.
- EXISTING CHAINLINK FENCE.
- EXISTING SPORTS FIELD AND RUNNING TRACK.
- EXISTING WOODED AREA.
- EXISTING ROCKY OUTCROP.
- EXISTING PORTABLE CLASSROOM.
- FUTURE PORTABLE CLASSROOM.
- EXISTING LOADING SPACES.
- NEW LOADING SPACES.
- TACTILE WALKING SURFACE INDICATOR

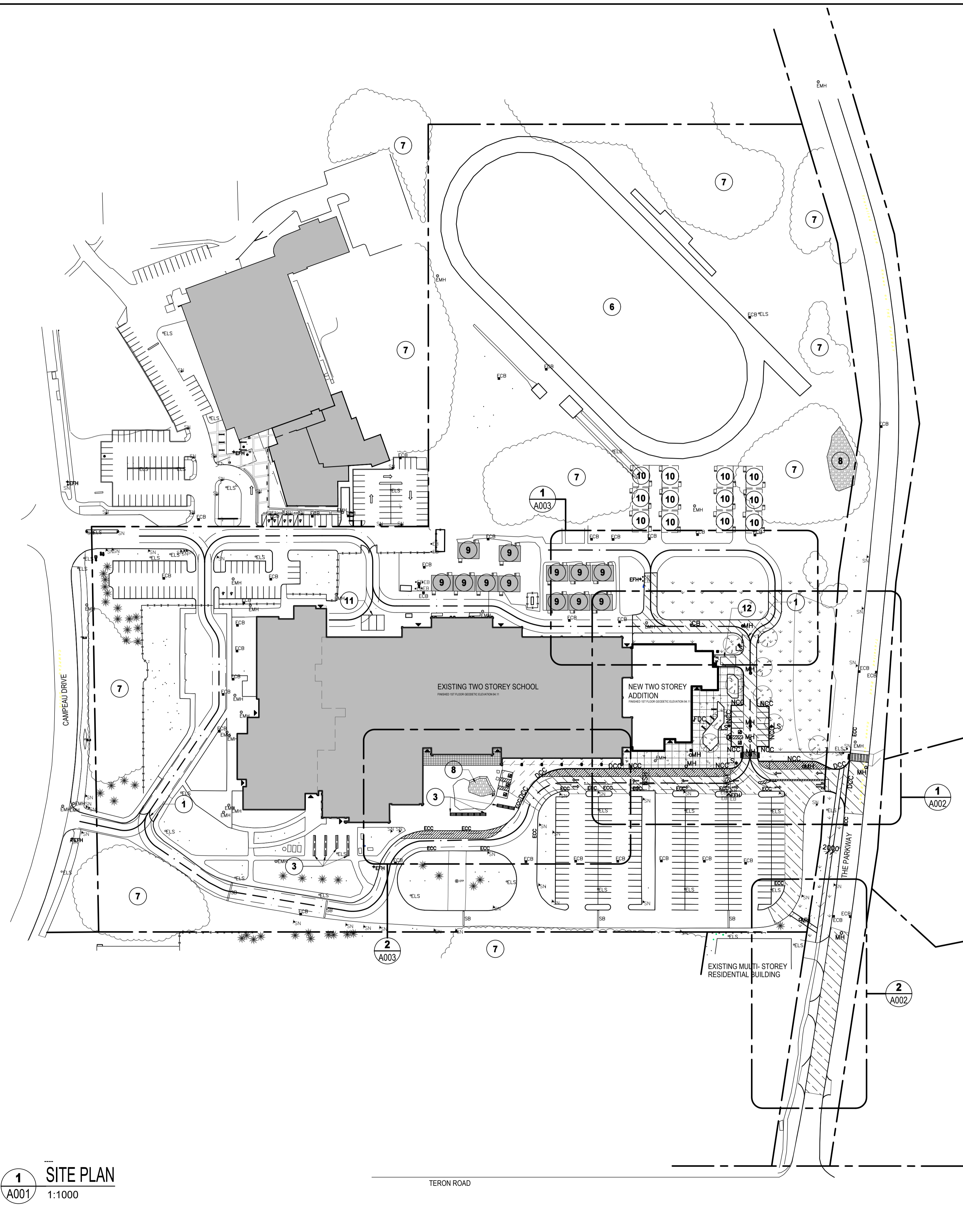

**1 SITE PLAN**  
 A001 1:1000

OTTAWA-CARLETON DISTRICT SCHOOL BOARD

ISSUE NO.	REV. NO.	DATE	ISSUE
1	0	2022/07/24	ISSUED FOR PHASE 2 SITE PLAN CONTROL

LES IDÉES, CONCEPTS, DISPOSITIONS ET PLANS MONTRÉS OU REPRÉSENTÉS PAR CE DESSIN APPARTIENNENT À EDWARD J. CUHACI AND ASSOCIATES ARCHITECTS INC. ET ONT ÉTÉ CRÉÉS, DÉVELOPPÉS POUR ÊTRE UTILISÉS DANS LE CADRE DU PRÉSENT PROJET. ILS NE DOIVENT PAS ÊTRE UTILISÉS À D'AUTRES FINS NI COMMUNIQUÉS À QUI QUE CE SOIT SANS LA PERMISSION ÉCRITE DE EDWARD J. CUHACI AND ASSOCIATES ARCHITECTS INC.

L'ARCHITECTE DÉCLINE TOUTE RESPONSABILITÉ DÉCOULANT DE PROBLÈMES FAISANT SUITE AU NON RESPECT DES PLANS ET DEVIS OU DE L'INTENTION DU CONCEPT QU'ILS TRANSMETTENT, OU DE TOUS PROBLÈMES POUVANT RÉSULTER DU DÉFAUT DE TIERS D'OBTENIR OU DE SUIVRE LES INSTRUCTIONS DE L'ARCHITECTE RELATIVEMENT AUX ERREURS, OMISSIONS, INCOHÉRENCES, AMBIGÜITÉS OU CONTRADICTIONS ALLEGUES.

L'ENTREPRENEUR DOIT VÉRIFIER TOUTES LES DIMENSIONS SUR PLACE ET INFORMER L'ARCHITECTE DE TOUT ÉCART AVANT LE DÉBUT DES TRAVAUX. NE PAS MESURER LES DESSINS À L'ÉCHELLE.

ALL IDEAS, DESIGNS, ARRANGEMENTS, AND PLANS INDICATED OR REPRESENTED BY THIS DRAWING ARE OWNED BY AND THE PROPERTY OF EDWARD J. CUHACI AND ASSOCIATES INC. AND WERE CREATED, EVOLVED, AND DEVELOPED FOR USE ON AND IN CONNECTION WITH THE SPECIFIED PROJECT. NONE OF THE IDEAS, DESIGNS, ARRANGEMENTS OR PLANS SHALL BE USED BY OR DISCLOSED TO ANY PERSON, FIRM, OR CORPORATION FOR ANY PURPOSE WHATSOEVER WITHOUT THE WRITTEN PERMISSION OF EDWARD J. CUHACI AND ASSOCIATES INC.

THE ARCHITECT WAIVES ANY AND ALL RESPONSIBILITY AND LIABILITY FOR PROBLEMS WHICH ARISE FROM FAILURE TO FOLLOW THESE PLANS, SPECIFICATIONS, AND THE DESIGN INTENT THEY CONVEY, OR FOR PROBLEMS WHICH ARISE FROM OTHERS' FAILURE TO OBTAIN AND/OR FOLLOW THE ARCHITECT'S GUIDANCE WITH RESPECT TO ANY ERRORS, OMISSIONS, INCONSISTENCIES, AMBIGUITIES OR CONFLICTS WHICH ARE ALLEGED.

CONTRACTOR TO VERIFY ALL DIMENSIONS AND NOTIFY THE ARCHITECT OF ANY DISCREPANCIES BEFORE WORK COMMENCES. DO NOT SCALE DRAWINGS

TRUE NORTH

PLAN NORTH

**EDWARD J CUHACI & ASSOCIATES ARCHITECTS Inc.**  
 171 Stater St, Suite 100, Ottawa, Ontario, K1P 5H7  
 Fax: (613) 236-1944 Telephone: (613) 236-7135 E-mail: info@cuhaci.com

PROJECT/TITRE DU PROJET  
**EARL OF MARCH SECONDARY SCHOOL ADDITION 2024**  
 4 THE PARKWAY  
 KANATA, ON, K2K 1Y4

OTTAWA-CARLETON DISTRICT SCHOOL BOARD  
 133 GREENBANK RD, OTTAWA

DRAWING/TITRE DU DESSIN  
**SITE PLAN**

SCALE	PROJ. No.	ISSUE No.	REV. No.
ECHELLE 1:1000	2411	1	0

DRAWN BY	DRAWING/DESSIN
AL/SL	DRAWING/DESSIN

CHECKED BY	DATE
XF	2024

**A001**

ACAD FILE/FICHER: 2411-A001.DWG

1	0	2024/07/24	ISSUED FOR PHASE 2 SITE PLAN CONTROL
ISSUE NO.	REV. NO.	DATE	ISSUE

LES IDÉES, CONCEPTS, DISPOSITIONS ET PLANS MONTRÉS OU REPRÉSENTÉS PAR CE DESSIN APPARTIENNENT À EDWARD J. CUHACI AND ASSOCIATES ARCHITECTS INC. ET ONT ÉTÉ CRÉÉS, ET DÉVELOPPÉS POUR ÊTRE UTILISÉS DANS LE CADRE DU PRÉSENT PROJET. ILS NE DOIVENT PAS ÊTRE UTILISÉS À D'AUTRES FINS NI COMMUNIQUÉS À QUI QUE CE SOIT SANS LA PERMISSION ÉCRITE DE EDWARD J. CUHACI AND ASSOCIATES ARCHITECTS INC.

L'ARCHITECTE DÉCLINE TOUTE RESPONSABILITÉ DÉCOULANT DE PROBLÈMES FAISANT SUITE AU NON RESPECT DES PLANS ET DEVIS OU DE L'INTENTION DU CONCEPT QU'ILS TRANSMETTENT, OU DE TOUS PROBLÈMES POUVANT RÉSULTER DU DÉFAUT DE TIERS D'OBTENIR OU DE SUIVRE LES INSTRUCTIONS DE L'ARCHITECTE RELATIVEMENT AUX ERREURS, OMISSIONS, INCOHÉRENCES, AMBIGÜITÉS OU CONTRADICTIONS ALLÉGUÉS.

L'ENTREPRENEUR DOIT VÉRIFIER TOUTES LES DIMENSIONS SUR PLACE ET INFORMER L'ARCHITECTE DE TOUT ÉCART AVANT LE DÉBUT DES TRAVAUX. NE PAS MESURER LES DESSINS À L'ÉCHELLE.

ALL IDEAS, DESIGNS, ARRANGEMENTS, AND PLANS INDICATED OR REPRESENTED BY THIS DRAWING ARE OWNED BY AND THE PROPERTY OF EDWARD J. CUHACI AND ASSOCIATES INC. AND WERE CREATED, EVOLVED, AND DEVELOPED FOR USE ON AND IN CONNECTION WITH THE SPECIFIED PROJECT. NONE OF THE IDEAS, DESIGNS, ARRANGEMENTS OR PLANS SHALL BE USED BY OR DISCLOSED TO ANY PERSON, FIRM, OR CORPORATION FOR ANY PURPOSE WHATSOEVER WITHOUT THE WRITTEN PERMISSION OF EDWARD J. CUHACI AND ASSOCIATES INC.

THE ARCHITECT WAIVES ANY AND ALL RESPONSIBILITY AND LIABILITY FOR PROBLEMS WHICH ARISE FROM FAILURE TO FOLLOW THESE PLANS, SPECIFICATIONS, AND THE DESIGN INTENT THEY CONVEY, OR FOR PROBLEMS WHICH ARISE FROM OTHERS' FAILURE TO OBTAIN AND/OR FOLLOW THE ARCHITECT'S GUIDANCE WITH RESPECT TO ANY ERRORS, OMISSIONS, INCONSISTENCIES, AMBIGUITIES OR CONFLICTS WHICH ARE ALLEGED.

CONTRACTOR TO VERIFY ALL DIMENSIONS AND NOTIFY THE ARCHITECT OF ANY DISCREPANCIES BEFORE WORK COMMENCES. DO NOT SCALE DRAWINGS

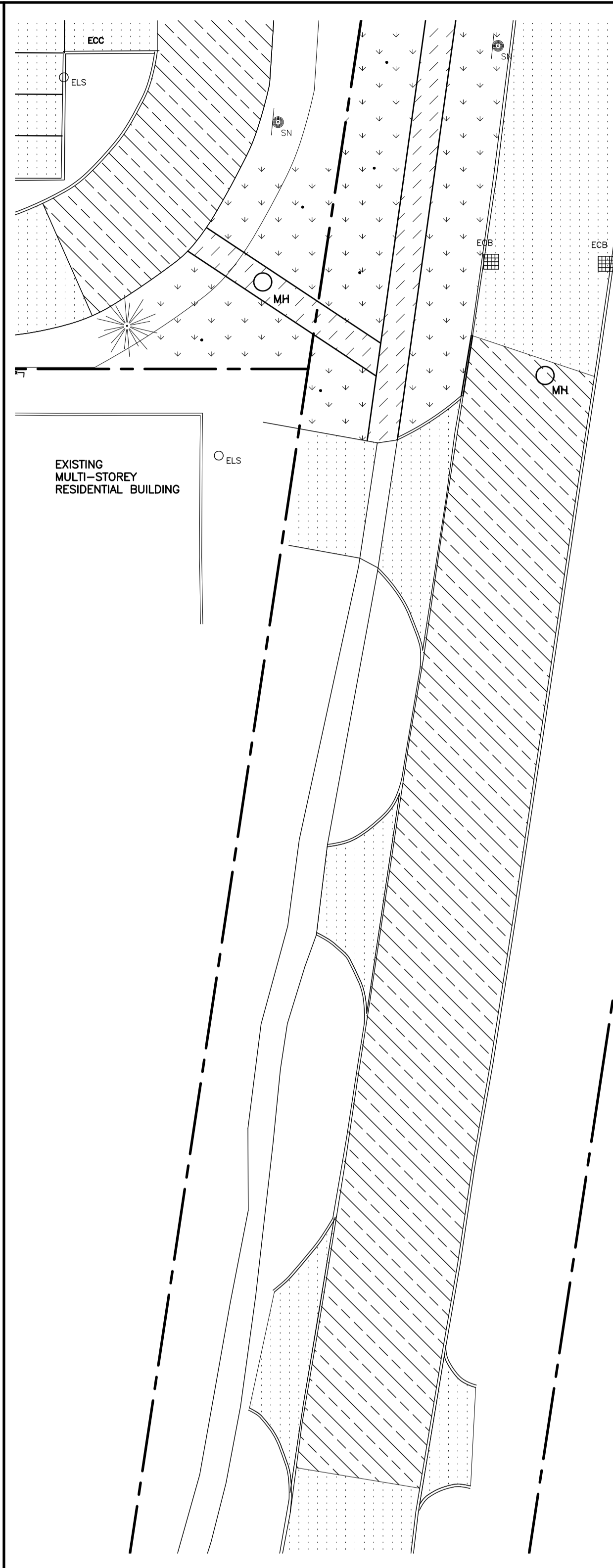
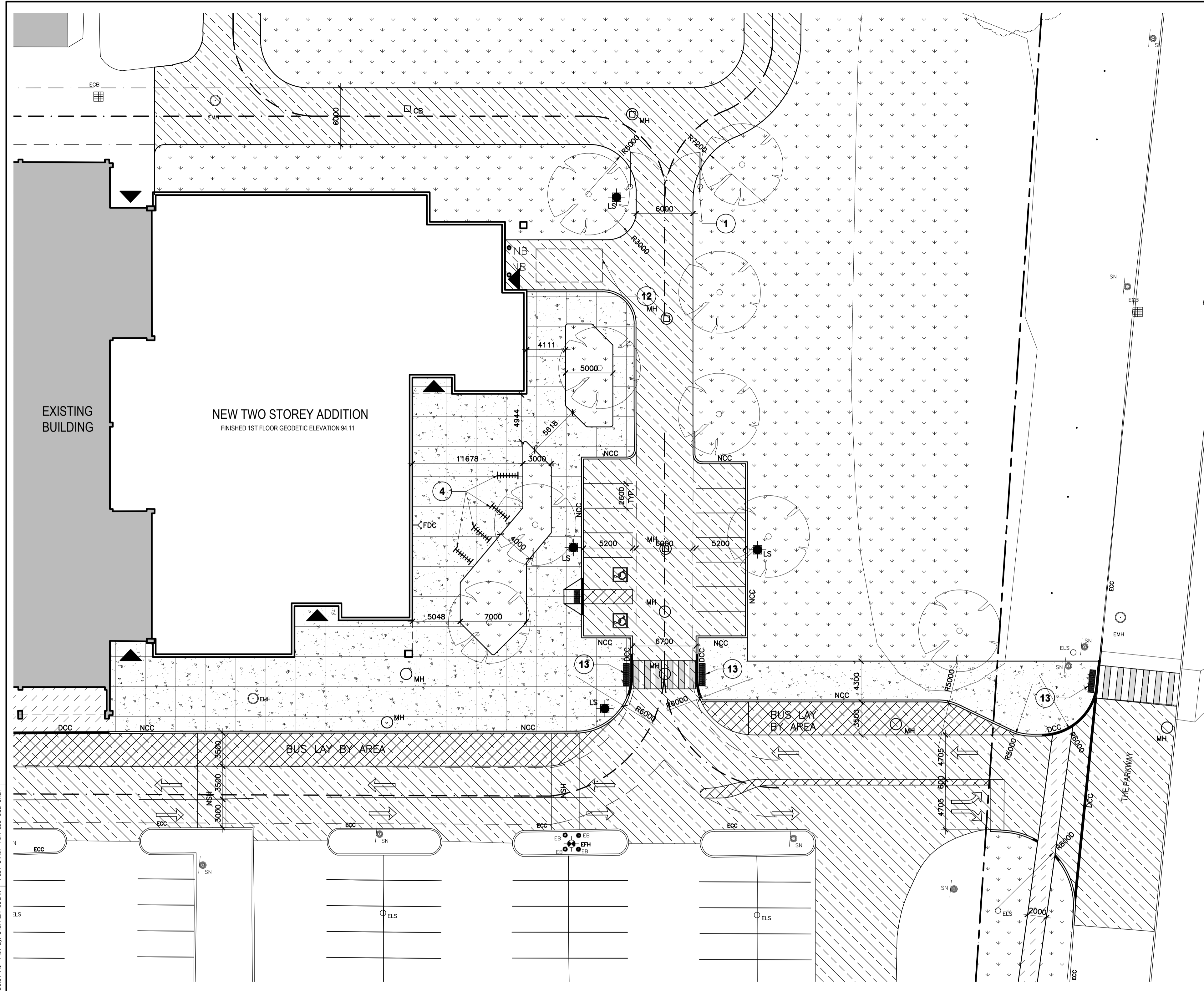
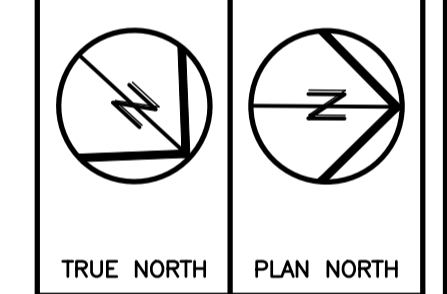

**1 PARTIAL SITE PLAN - NEW WORK**  
A002 1:250

**2 ASPHALT AND PATHWAY REINSTATEMENT**  
A002 1:250

**DRAWING LEGEND**

<ul style="list-style-type: none"> <li> BARRIER FREE PARKING</li> <li> BUILDING ENTRANCE/EXIT</li> <li> EXISTING BUILDING</li> <li> EXISTING INTERLOCK PAVERS</li> <li> EXISTING ASPHALT PAVING</li> <li> EXISTING CONCRETE WALKWAY</li> <li> NEW SOD AND TOPSOIL (REFER ALSO TO LANDSCAPE PLAN)</li> <li> NEW CONCRETE WALKWAY WITH CONTROL JOINTS</li> <li> NEW TYPE 1 ASPHALT - HEAVY DUTY (REFER TO SPEC.)</li> <li> NEW TYPE 2 ASPHALT - MEDIUM DUTY (REFER TO SPEC.)</li> </ul>	<ul style="list-style-type: none"> <li> EXISTING SPEED BUMPS TO REMAIN</li> <li> EXISTING SIGN</li> <li> EXISTING BOLLARD</li> <li> EXISTING CONCRETE CURB TO REMAIN</li> <li> EXISTING DEPRESSED CONCRETE CURB</li> <li> EXISTING FIRE HYDRANT</li> <li> NEW SPEED HUMPS</li> <li> NEW PAINTED PEDESTRIAN CROSSING</li> <li> NEW 'FIRE ROUTE' SIGN</li> <li> NEW 'NO ENTRY BUS ONLY' SIGN</li> <li> NEW BOLLARD</li> <li> NEW CONCRETE CURB</li> <li> NEW DEPRESSED CONCRETE CURB</li> <li> NEW BICYCLE RACK</li> </ul>	<ul style="list-style-type: none"> <li> EXISTING FLAG POLE</li> <li> EXISTING CATCH BASIN</li> <li> EXISTING UTILITY POLE</li> <li> EXISTING LIGHT STANDARD</li> <li> NEW PARKING LOT LIGHT STANDARD (REFER TO ELECTRICAL)</li> <li> EXISTING GOAL POST</li> <li> EXISTING MAN HOLE</li> <li> NEW MAN HOLE. REFER TO CIVIL</li> <li> NEW CATCH BASIN. REFER TO CIVIL</li> <li> EXISTING FENCE</li> <li> PROPERTY LOT LINE</li> <li> PROPERTY SETBACK LINES</li> <li> FIRE ROUTE</li> <li> EXISTING TREE TO REMAIN, REFER TO LANDSCAPE</li> </ul>	<ul style="list-style-type: none"> <li> EXISTING PORTABLE CLASSROOM</li> <li> FUTURE PORTABLE CLASSROOM</li> <li> NEW TREES - SEE LANDSCAPE DRAWINGS.</li> </ul>
---	--	--	--

**DRAWING NOTES**

- 1 NEW GATE. REFER TO A004
- 2 EXISTING GATE.
- 3 EXISTING BICYCLE RACK.
- 4 NEW BICYCLE RACK.
- 5 EXISTING CHAINLINK FENCE.
- 6 EXISTING SPORTS FIELD AND RUNNING TRACK.
- 7 EXISTING WOODED AREA.
- 8 EXISTING ROCKY OUTCROP.
- 9 EXISTING PORTABLE CLASSROOM.
- 10 FUTURE PORTABLE CLASSROOM.
- 11 EXISTING LOADING SPACES.
- 12 NEW LOADING SPACES.
- 13 TACTILE WALKING SURFACE INDICATOR

**EDWARD J CUHACI & ASSOCIATES ARCHITECTS Inc.**  
171 Slater St, Suite 100, Ottawa, Ontario, K1P 5H7  
Fax: (613) 236-1944 Telephone: (613) 236-7135 E-mail: info@cuhaci.com

PROJECT TITLE/TITRE DU PROJET  
**EARL OF MARCH SECONDARY SCHOOL ADDITION 2024**  
4 THE PARKWAY  
KANATA, ON, K2K 1Y4

OTTAWA-CARLETON DISTRICT SCHOOL BOARD  
133 GREENBANK RD, OTTAWA

DRAWING TITLE/TITRE DU DESSIN  
**PARTIAL SITE PLAN**

SCALE ECHELLE	1:250	PROJ. No	2411	ISSUE No	1	REV. No	0
DRAWN BY DESSINE PAR	AL/SL	DRAWING/DESSIN					<b>A002</b>
CHECKED BY VÉRIFIÉ PAR	XF	ACAD FILE/FICHER: 2411-A002.DWG					
DATE	2024						

DRAWING LEGEND

- BARRIER FREE PARKING
- BUILDING ENTRANCE/EXIT
- EXISTING BUILDING
- EXISTING INTERLOCK PAVERS
- EXISTING ASPHALT PAVING
- EXISTING CONCRETE WALKWAY
- NEW SOD AND TOPSOIL (REFER ALSO TO LANDSCAPE PLAN)
- NEW CONCRETE WALKWAY WITH CONTROL JOINTS
- NEW TYPE 1 ASPHALT - HEAVY DUTY (REFER TO SPEC.)
- NEW TYPE 2 ASPHALT - MEDIUM DUTY (REFER TO SPEC.)

- EXISTING SPEED BUMPS TO REMAIN
- EXISTING SIGN
- EXISTING BOLLARD
- EXISTING CONCRETE CURB TO REMAIN
- EXISTING DEPRESSED CONCRETE CURB
- EXISTING FIRE HYDRANT
- NEW SPEED HUMPS
- NEW PAINTED PEDESTRIAN CROSSING
- NEW 'FIRE ROUTE' SIGN
- NEW 'NO ENTRY BUS ONLY' SIGN
- NEW BOLLARD
- NEW CONCRETE CURB
- NEW DEPRESSED CONCRETE CURB
- NEW BICYCLE RACK
- EXISTING FLAG POLE
- EXISTING CATCH BASIN
- EXISTING UTILITY POLE
- EXISTING LIGHT STANDARD
- NEW PARKING LOT LIGHT STANDARD (REFER TO ELECTRICAL)
- EXISTING GOAL POST
- EXISTING MAN HOLE
- NEW MAN HOLE. REFER TO CIVIL
- NEW CATCH BASIN. REFER TO CIVIL
- EXISTING FENCE
- PROPERTY LOT LINE
- PROPERTY SETBACK LINES
- FIRE ROUTE

- EXISTING TREE TO REMAIN, REFER TO LANDSCAPE DOCUMENTS
- EXISTING PORTABLE CLASSROOM
- FUTURE PORTABLE CLASSROOM
- NEW TREES - SEE LANDSCAPE DRAWINGS.

DRAWING NOTES

- 1 NEW GATE. REFER TO A004
- 2 EXISTING GATE.
- 3 EXISTING BICYCLE RACK.
- 4 NEW BICYCLE RACK.
- 5 EXISTING CHAINLINK FENCE.
- 6 EXISTING SPORTS FIELD AND RUNNING TRACK.
- 7 EXISTING WOODED AREA.
- 8 EXISTING ROCKY OUTCROP.
- 9 EXISTING PORTABLE CLASSROOM.
- 10 FUTURE PORTABLE CLASSROOM.
- 11 EXISTING LOADING SPACES.
- 12 NEW LOADING SPACES.
- 13 TRAFFIC WALKING SURFACE INDICATOR

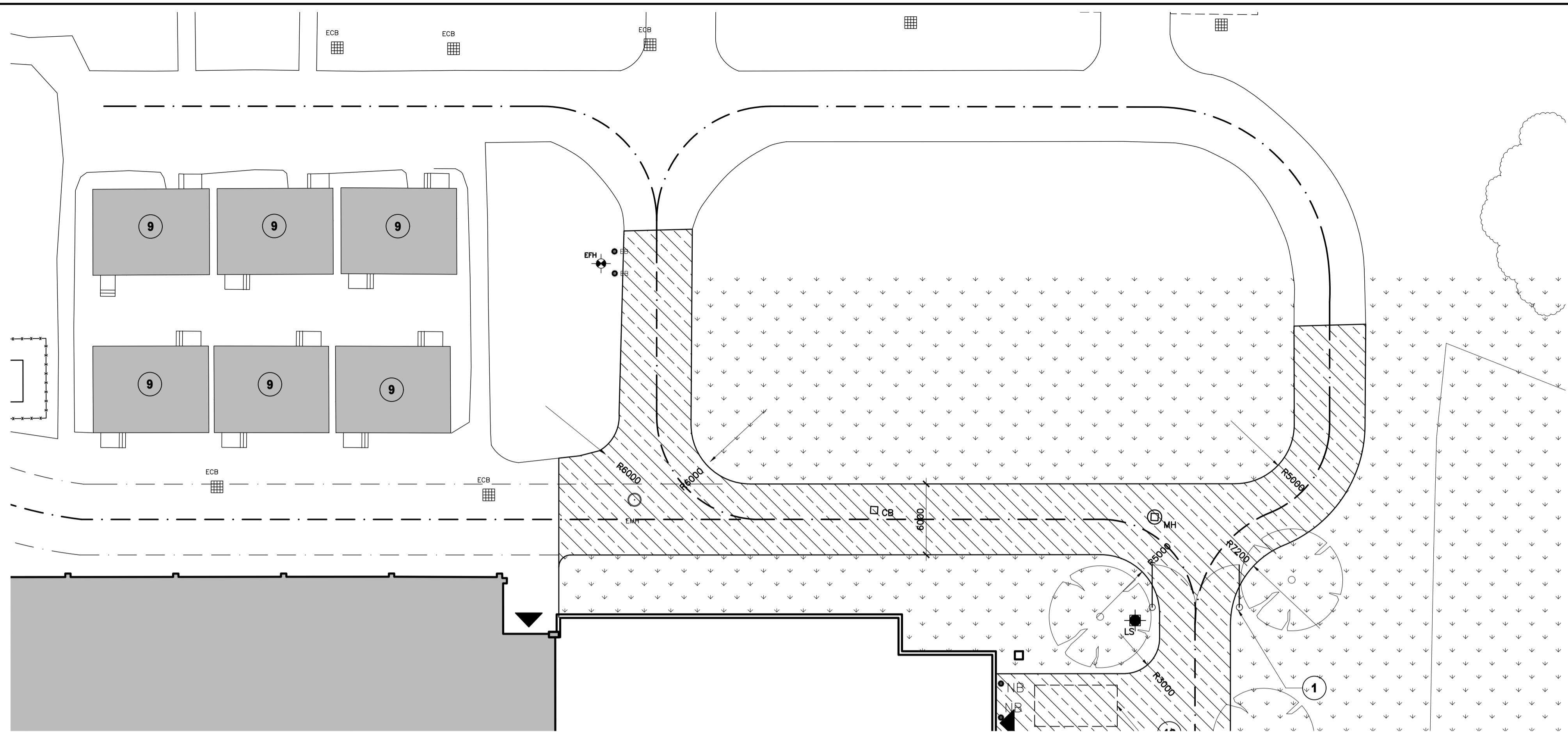

1 PARTIAL SITE PLAN @ PORTABLES  
A003 1:250

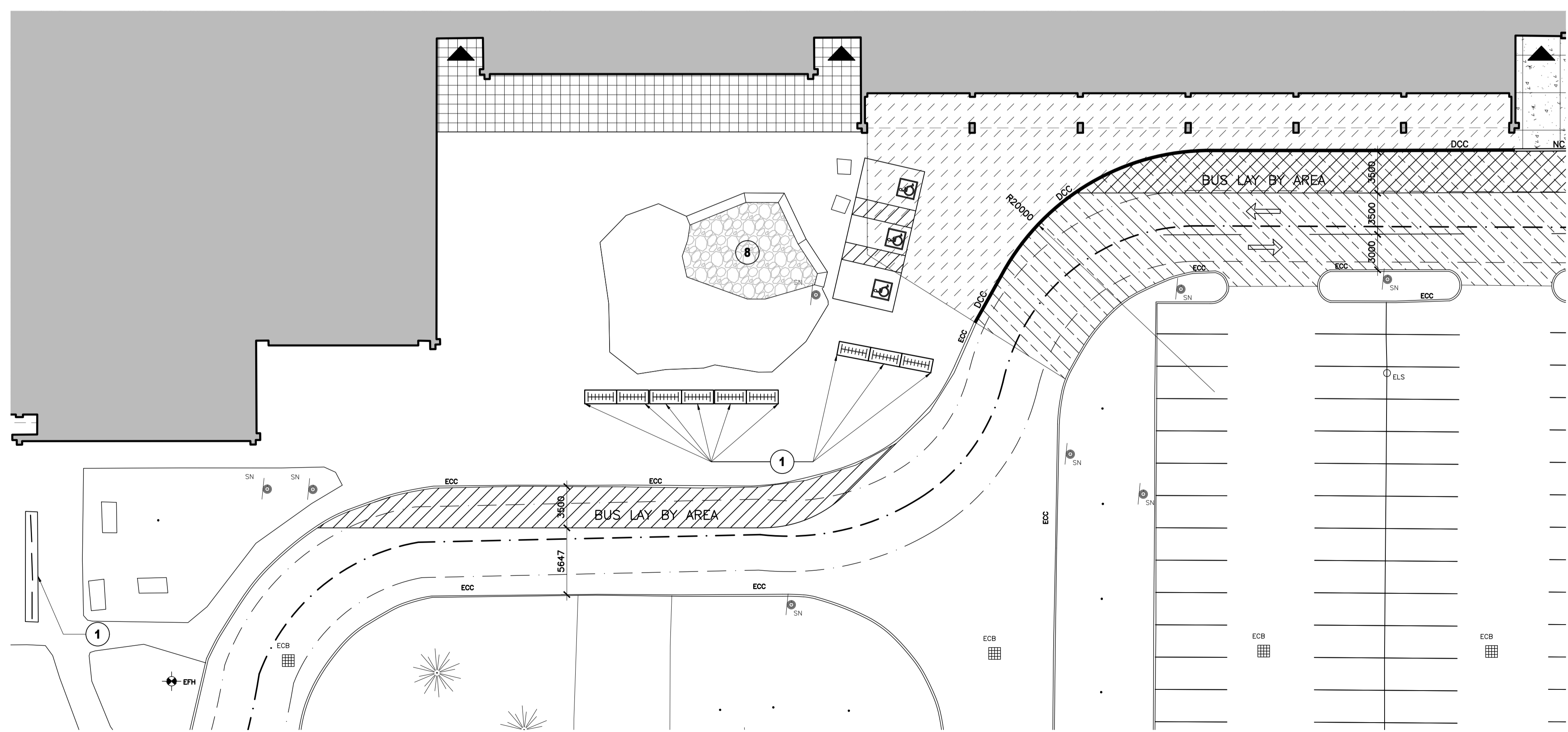

2 PARTIAL SITE PLAN @ NEW BUS LAYBY  
A003 1:250



OTTAWA-CARLETON DISTRICT SCHOOL BOARD

ISSUE NO.	REV. NO.	DATE	ISSUE
1	0	2024/07/24	ISSUED FOR PHASE 2 SITE PLAN CONTROL

LES IDÉES, CONCEPTS, DISPOSITIONS ET PLANS MONTRÉS OU REPRÉSENTÉS PAR CE DESSIN APPARTIENNENT À EDWARD J. CUHACI AND ASSOCIATES ARCHITECTS INC. ET ONT ÉTÉ CRÉÉS, DÉVELOPPÉS POUR ÊTRE UTILISÉS DANS LE CADRE DU PRÉSENT PROJET. ILS NE DOIVENT PAS ÊTRE UTILISÉS À D'AUTRES FINS NI COMMUNIQUÉS À QUI QUE CE SOIT SANS LA PERMISSION ÉCRITE DE EDWARD J. CUHACI AND ASSOCIATES ARCHITECTS INC.

L'ARCHITECTE DÉCLINE TOUTE RESPONSABILITÉ DÉCOULANT DE PROBLÈMES FAISANT SUITE AU NON RESPECT DES PLANS ET DEVIS OU DE L'INTENTION DU CONCEPT QU'ILS TRANSMETTENT, OU DE TOUS PROBLÈMES POUVANT RÉSULTER DU DÉFAUT DE TIERS D'OBTENIR OU DE SUIVRE LES INSTRUCTIONS DE L'ARCHITECTE RELATIVEMENT AUX ERREURS, OMISSIONS, INCOHÉRENCES, AMBIGÜITÉS OU CONTRADICTIONS ALLEGUES.

L'ENTREPRENEUR DOIT VÉRIFIER TOUTES LES DIMENSIONS SUR PLACE ET INFORMER L'ARCHITECTE DE TOUT ÉCART AVANT LE DÉBUT DES TRAVAUX. NE PAS MESURER LES DESSINS À L'ÉCHELLE.

ALL IDEAS, DESIGNS, ARRANGEMENTS, AND PLANS INDICATED OR REPRESENTED BY THIS DRAWING ARE OWNED BY AND THE PROPERTY OF EDWARD J. CUHACI AND ASSOCIATES INC. AND WERE CREATED, EVOLVED, AND DEVELOPED FOR USE ON AND IN CONNECTION WITH THE SPECIFIED PROJECT. NONE OF THE IDEAS, DESIGNS, ARRANGEMENTS OR PLANS SHALL BE USED BY OR DISCLOSED TO ANY PERSON, FIRM, OR CORPORATION FOR ANY PURPOSE WHATSOEVER WITHOUT THE WRITTEN PERMISSION OF EDWARD J. CUHACI AND ASSOCIATES INC.

THE ARCHITECT WAIVES ANY AND ALL RESPONSIBILITY AND LIABILITY FOR PROBLEMS WHICH ARISE FROM FAILURE TO FOLLOW THESE PLANS, SPECIFICATIONS, AND THE DESIGN INTENT THEY CONVEY, OR FOR PROBLEMS WHICH ARISE FROM OTHERS' FAILURE TO OBTAIN AND/OR FOLLOW THE ARCHITECT'S GUIDANCE WITH RESPECT TO ANY ERRORS, OMISSIONS, INCONSISTENCIES, AMBIGUITIES OR CONFLICTS WHICH ARE ALLEGED.

CONTRACTOR TO VERIFY ALL DIMENSIONS AND NOTIFY THE ARCHITECT OF ANY DISCREPANCIES BEFORE WORK COMMENCES. DO NOT SCALE DRAWINGS

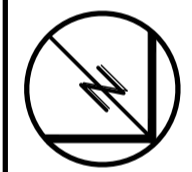

TRUE NORTH

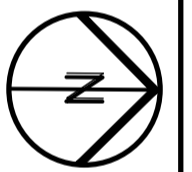

PLAN NORTH

**EDWARD J CUHACI & ASSOCIATES ARCHITECTS Inc.**  
171 Slater St, Suite 100, Ottawa, Ontario, K1P 5H7  
Fax: (613) 236-1944 Telephone: (613) 236-7135 E-mail: info@cuhaci.com

PROJECT TITLE/TITRE DU PROJET  
**EARL OF MARCH SECONDARY SCHOOL ADDITION 2024**  
4 THE PARKWAY  
KANATA, ON, K2K 1Y4

OTTAWA-CARLETON DISTRICT SCHOOL BOARD  
133 GREENBANK RD, OTTAWA





DRAWING TITLE/TITRE DU DESSIN  
**PARTIAL SITE PLAN**

SCALE	PROJ. No	ISSUE No	REV. No
ECHELLE	1:250	2411	1 0
DRAWN BY	AL/SL	DRAWING/DESSIN	
CHECKED BY	XF	<b>A003</b>	
DATE	2024	ACAD FILE/FICHER: 2411-A003.DWG	

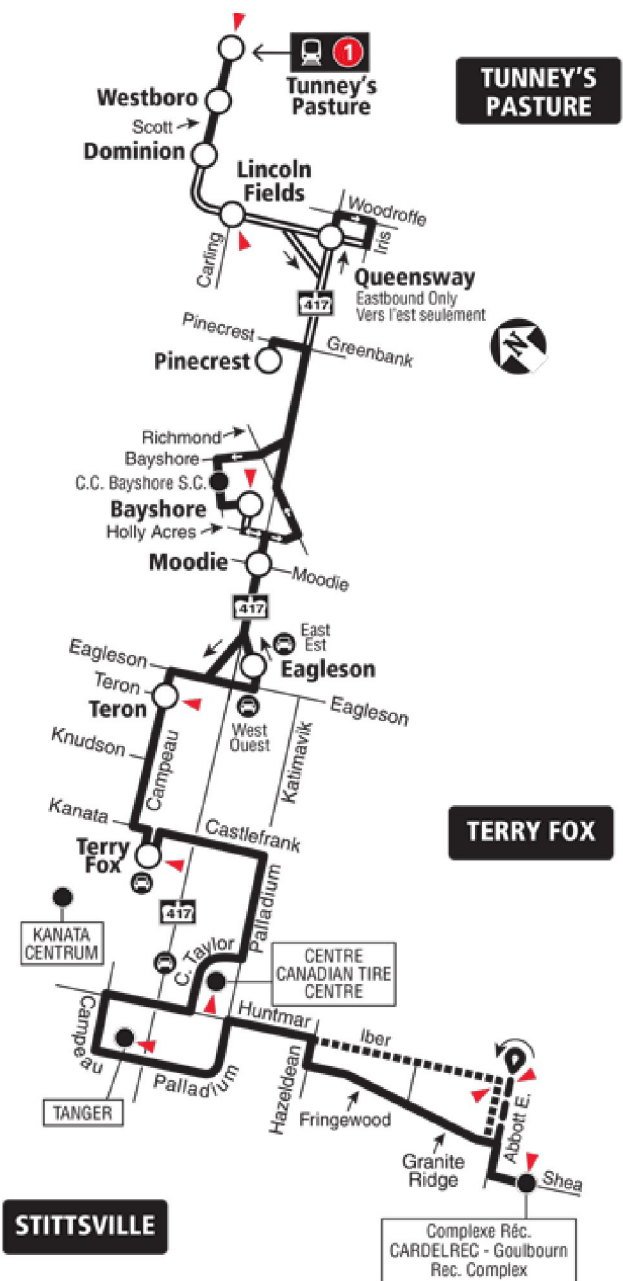
# Appendix B:





Transit Route Maps

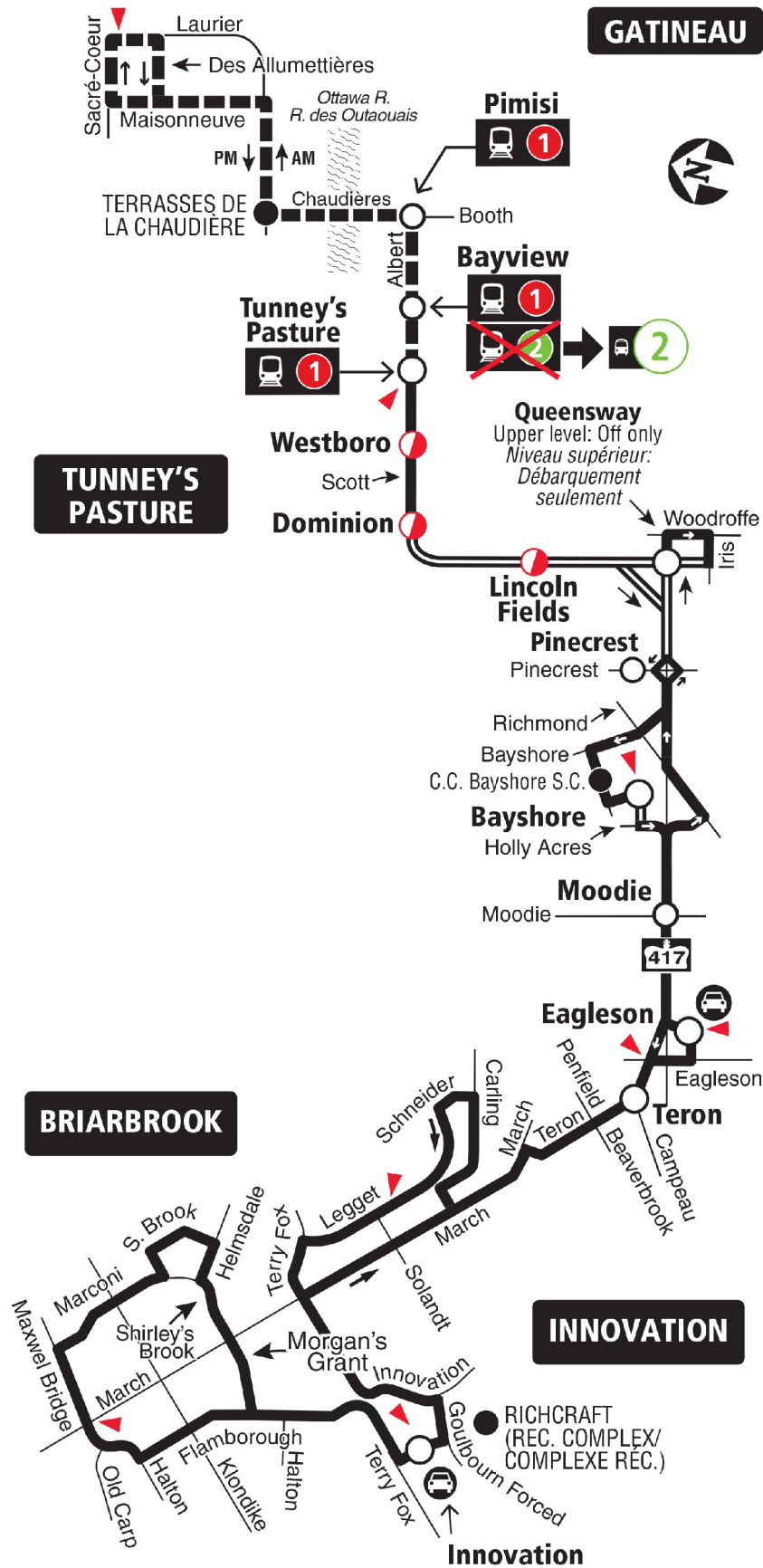

-  Transitway & Station
-  Weekday southbound trips before noon and weekday northbound trips between noon and 8 p.m. travel via Iber and Abbott E.  
Trajets en semaine vers le sud en avant midi et trajets en semaine vers le nord entre midi et 20 h via Iber et Abbott E.
-  Saturday and Sunday / Samedi et dimanche
-  Park & Ride / Parc-o-bus
-  Timepoint / Heures de passage

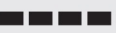
2022.12



-  Transitway & Station
-  Peak Periods Only / Périodes de pointe seulement
-  Eastbound: AM Off only - Westbound: Full Service  
Vers l'est AM: Débarquement seulement  
Vers l'ouest: Service complet
-  Park & Ride / Parc-o-bus
-  Timepoint / Heures de passage

2022.06

**TUNNEY'S PASTURE**

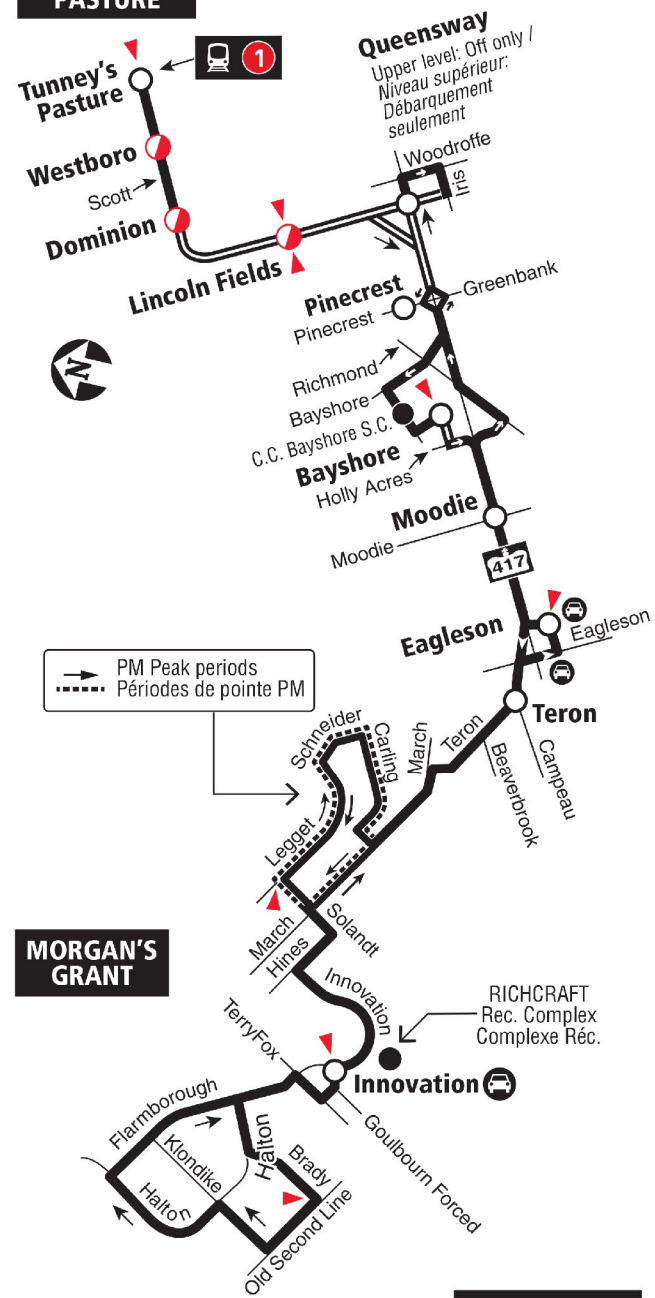

**INNOVATION**



- Transitway & Station
- Eastbound: AM Off only - Westbound: Full Service  
Vers l'est AM: Débarquement seulement  
Vers l'ouest: Service complet
- Park & Ride / Parc-o-bus
- Timepoint / Heures de passage

2022.06

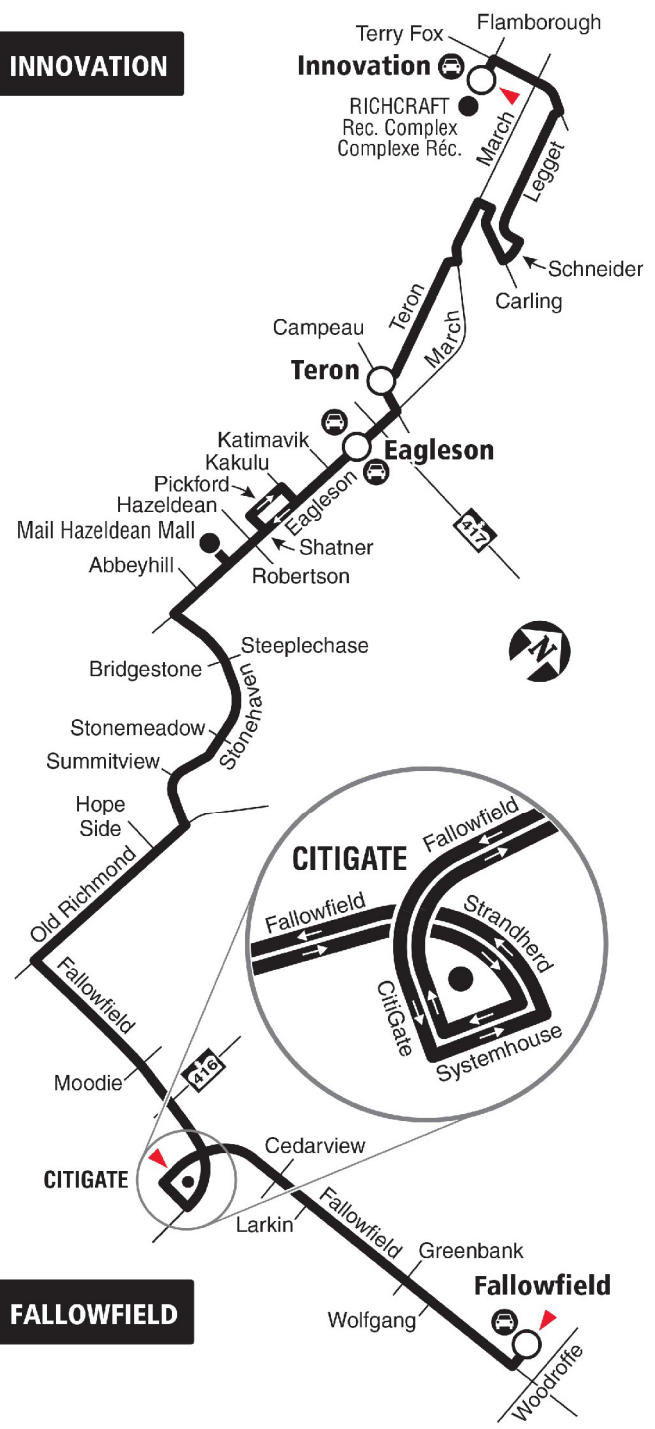
**INNOVATION**



**FALLOWFIELD**

	Stations
	Park & Ride / Parc-o-bus
	Timepoint / Heures de passage



**TERRY FOX**

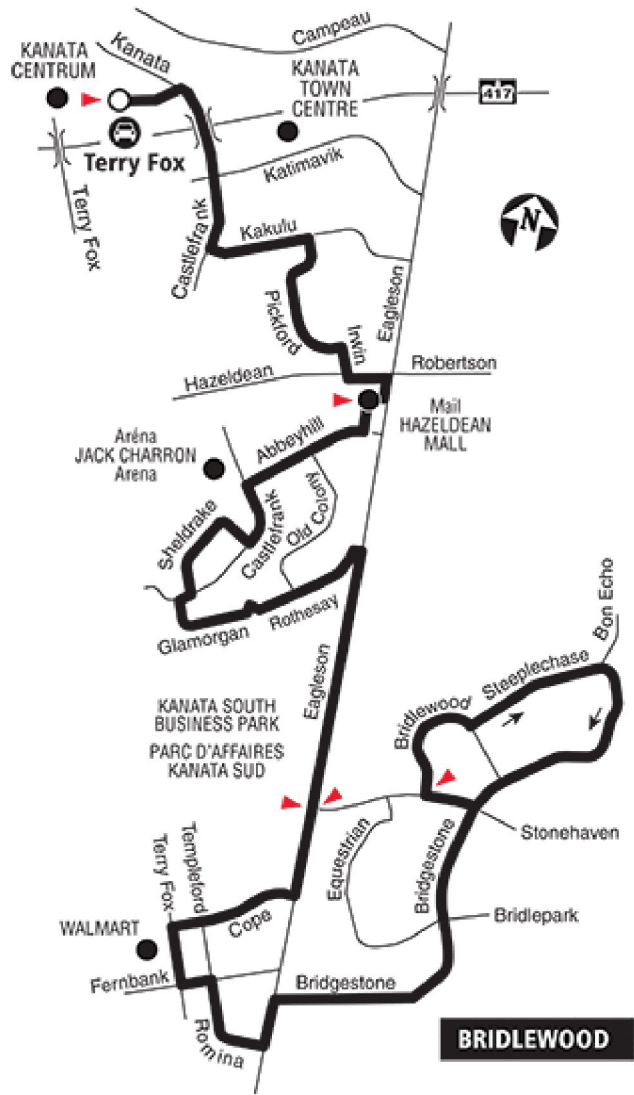

**BRIDLEWOOD**

- Station
- 🚌 Park & Ride / Parc-o-bus
- ▲ Timepoint / Heures de passage

**AM**  
↑  
**TERRY FOX**

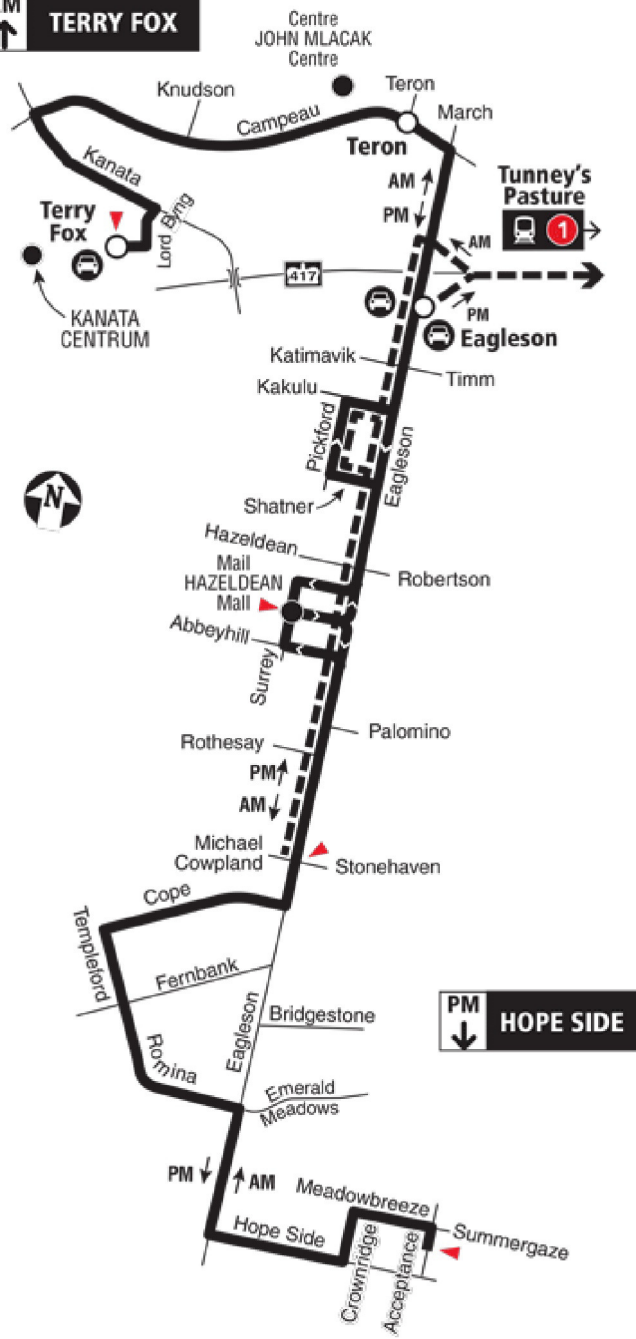

- Transitway Station / Station du Transitway
- ■ ■ ■ Peak Periods Only / Périodes de pointe seulement  
Some trips to / from Tunney's Pasture  
Quelques trajets de / vers Tunney's Pasture
- 🚌 Park & Ride / Parc-o-bus
- ▲ Timepoint / Heures de passage

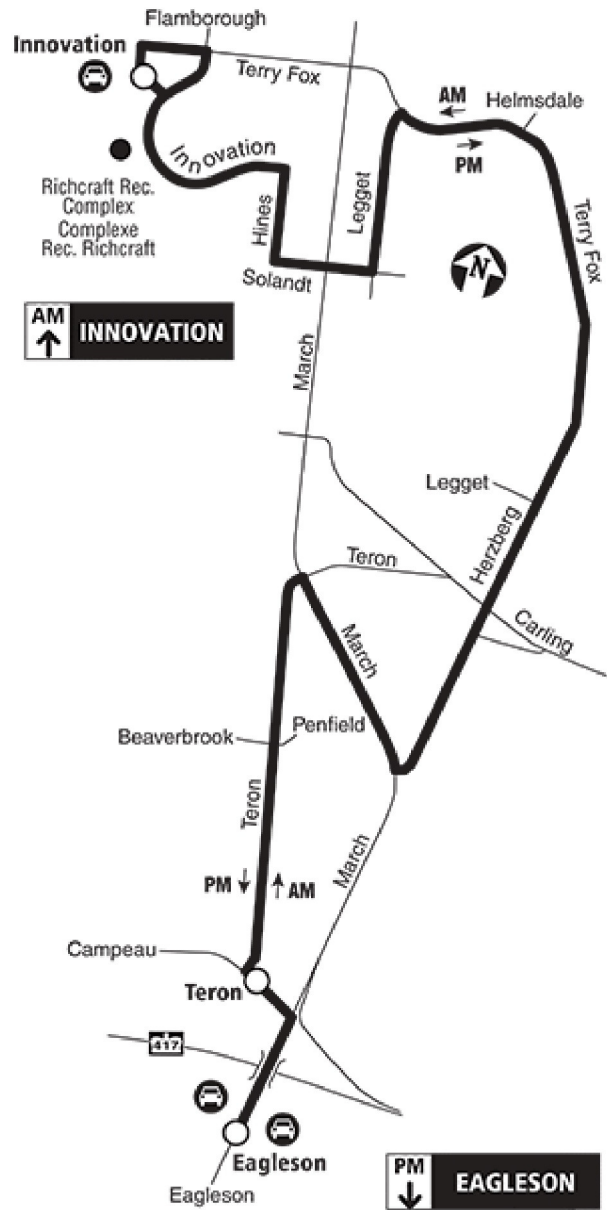

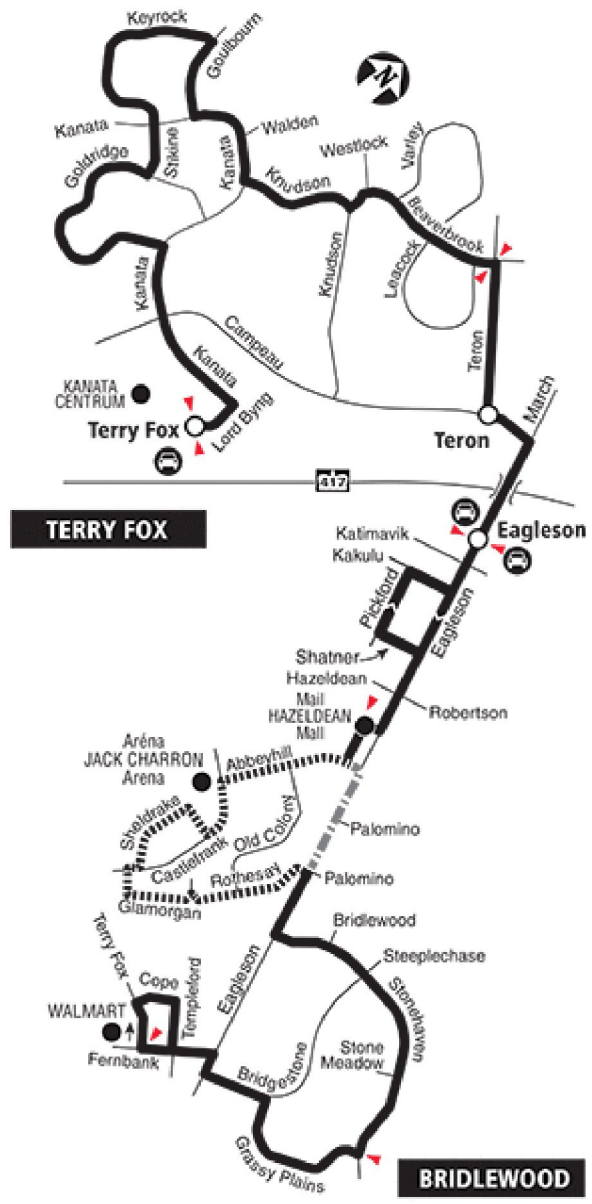

**TERRY FOX**

**BRIDLEWOOD**

- Transitway Station / Station du Transitway
- ⋯ Saturday and Sunday only  
Samedi et dimanche seulement
- ⋮ No weekend service  
Aucun service la fin de semaine
- 🚗 Park & Ride / Parc-o-bus
- ▲ Timepoint / Heures de passage

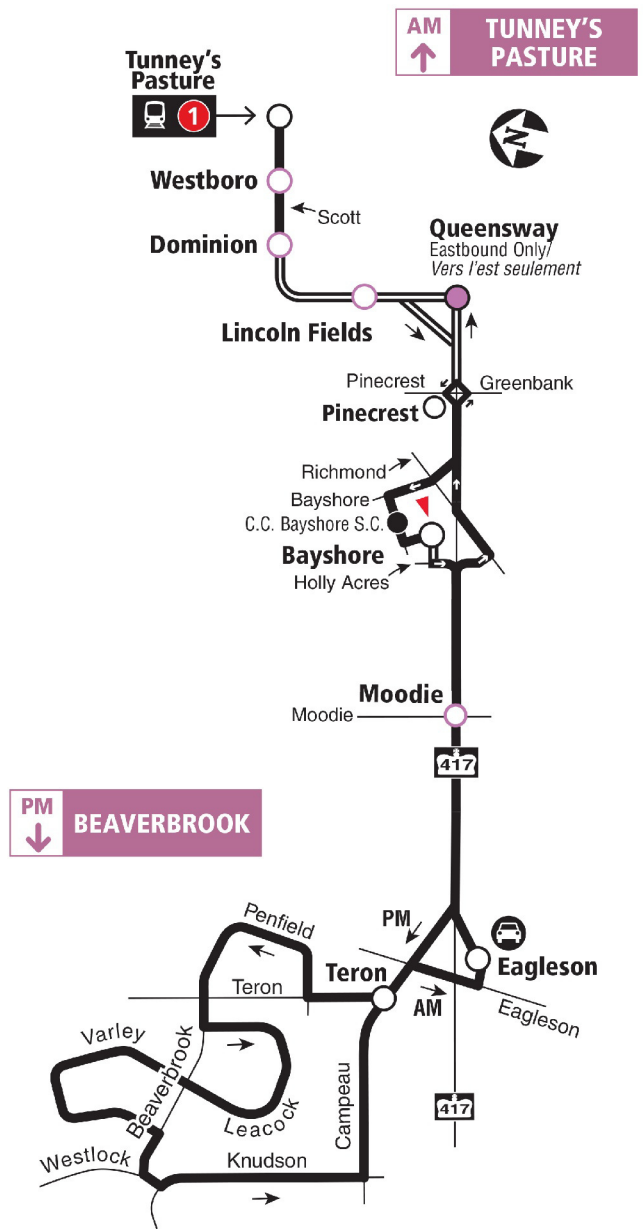

2022.06

- Transitway & Station
- Limited stops: Off only in AM / No stop in PM  
Arrêts limités : débarquement en AM seul. / aucun arrêt en PM
- AM: Off only - PM: Full Service  
AM : débarquement seul. - PM : service complet
- Park & Ride / Parc-o-bus

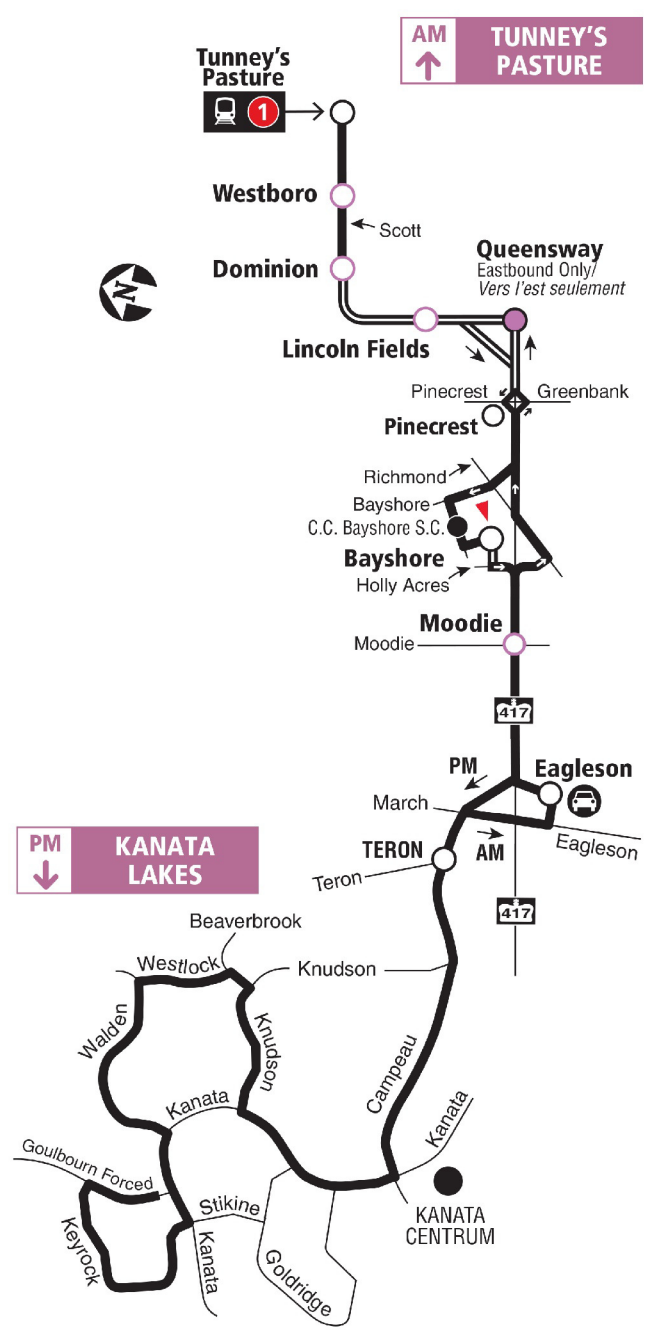

- 2022.06
- Transitway & Station
  - Limited stops: Off only in AM / No stop in PM  
Arrêts limités : débarquement en AM seul. / aucun arrêt en PM
  - AM: Off only - PM: Full Service  
AM : débarquement seul. - PM : service complet
  - Park & Ride / Parc-o-bus

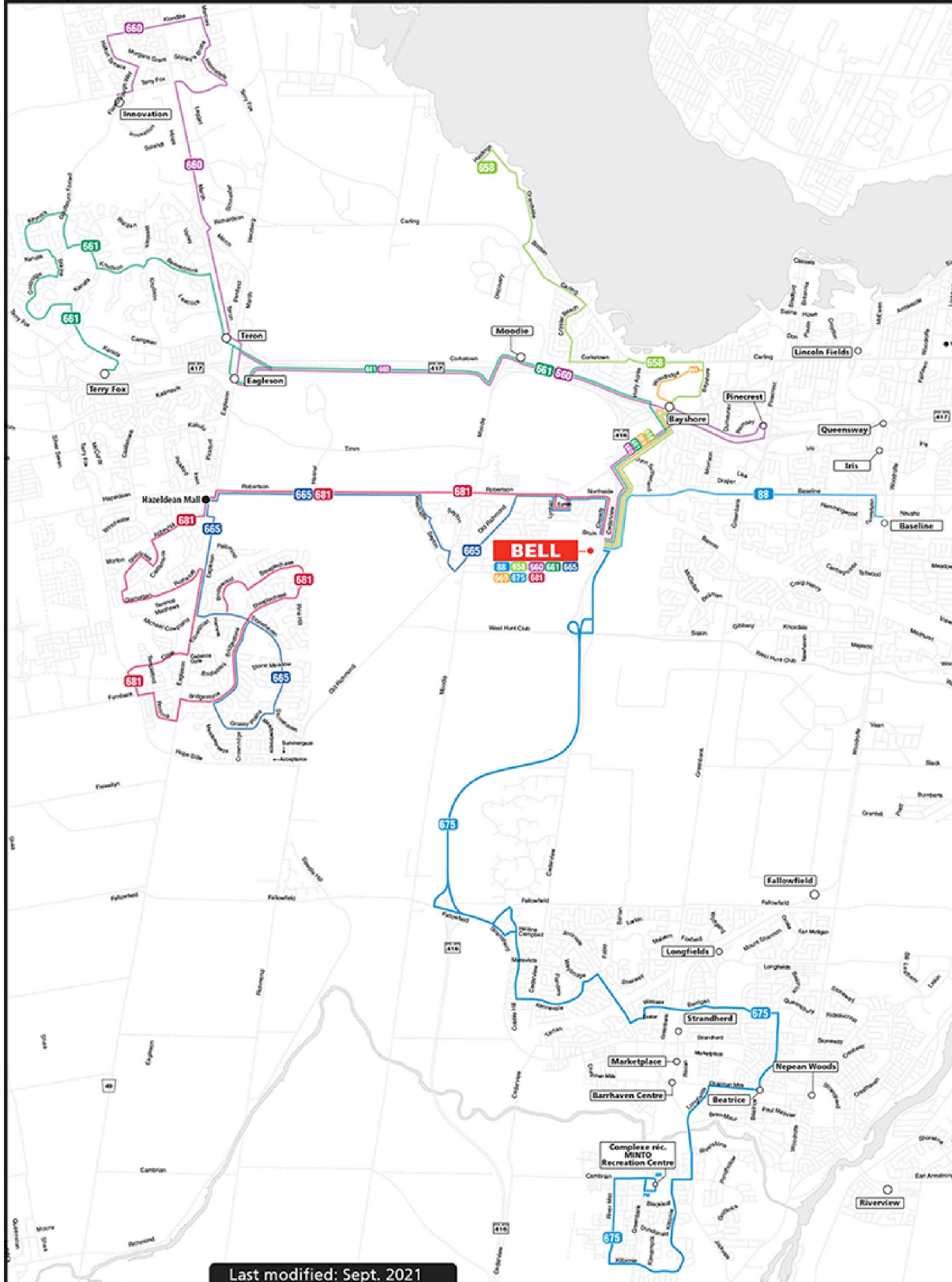

Last modified: Sept. 2021

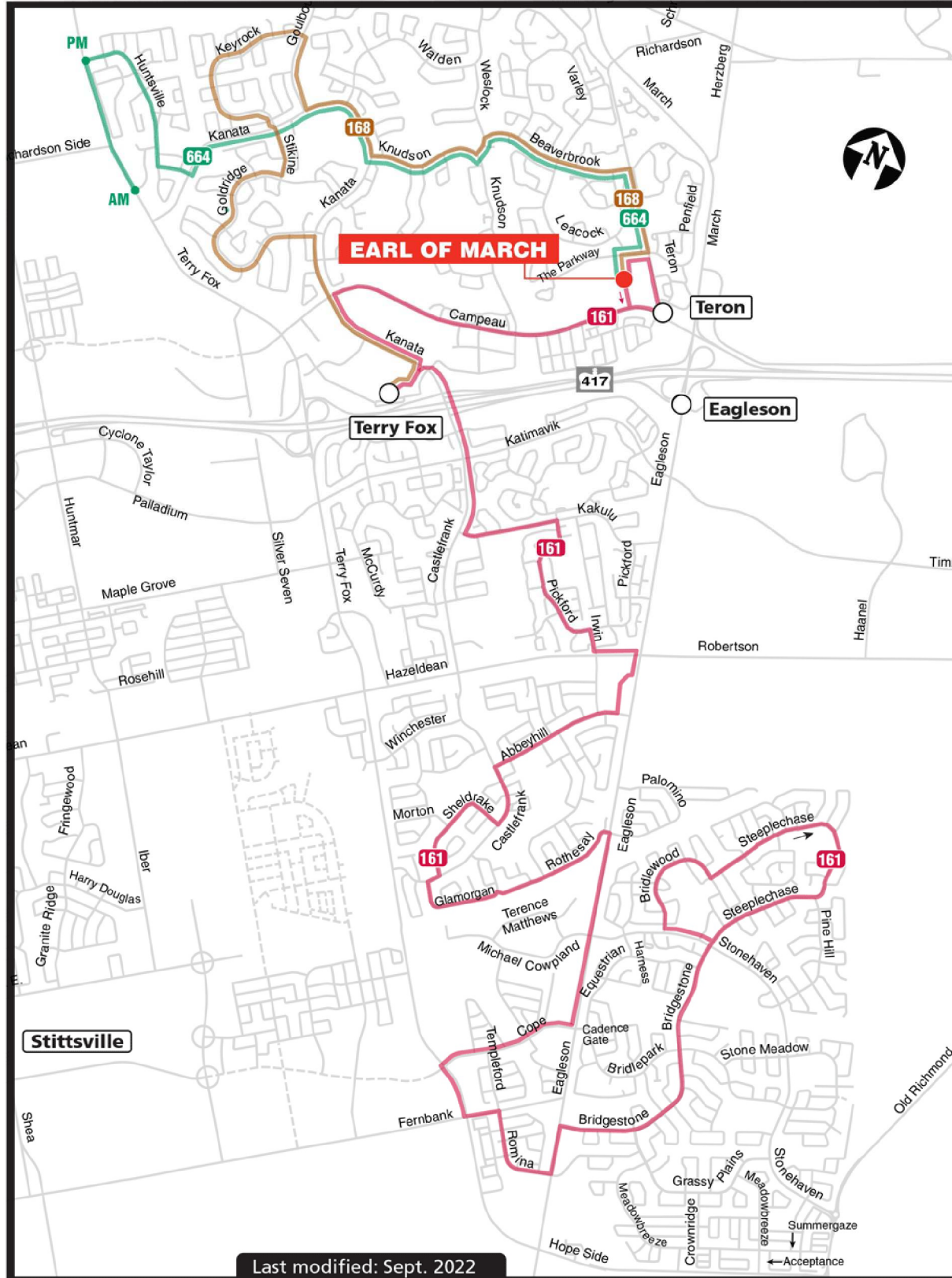



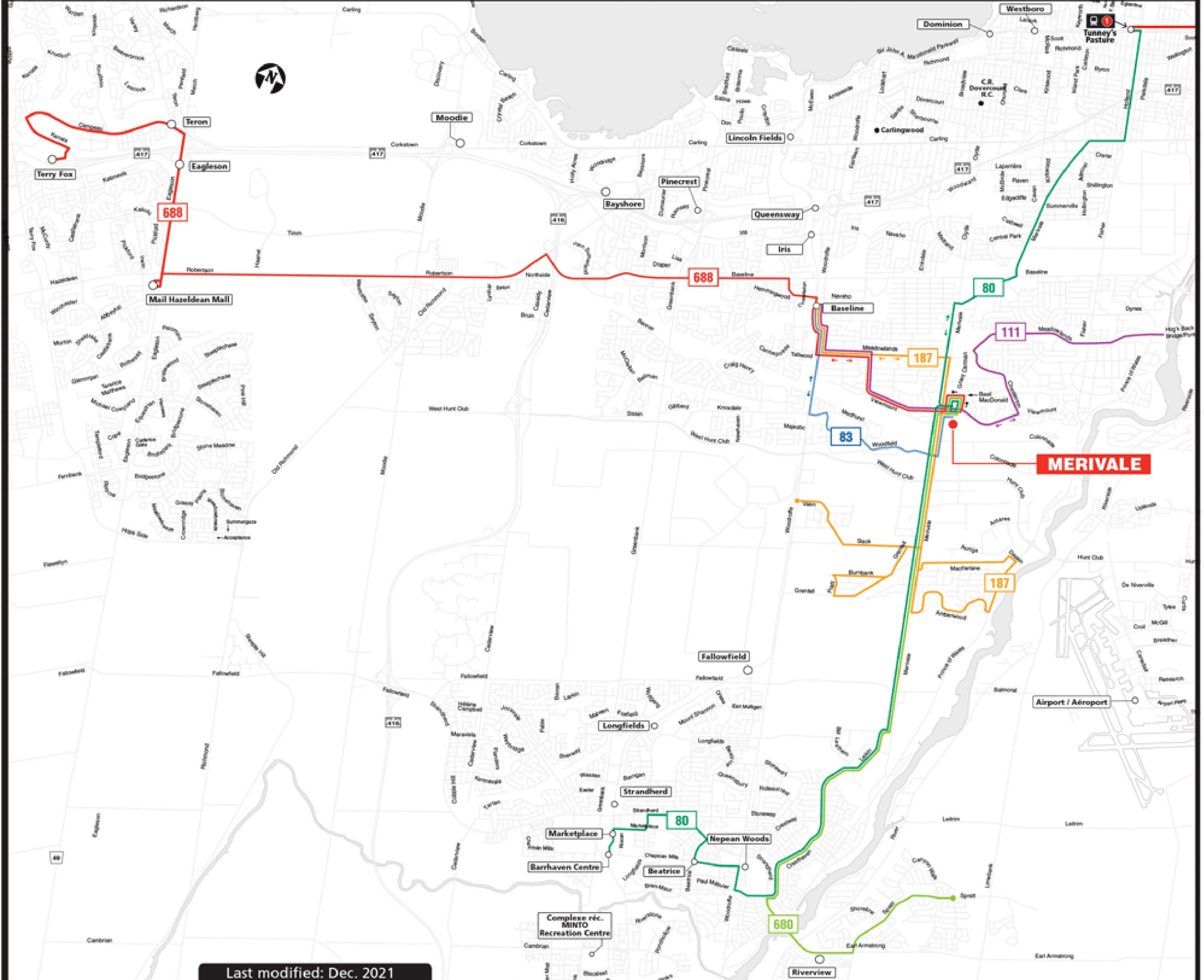

# **Appendix C:**

**Existing Peak Hour Volumes**



# Turning Movement Count Summary, AM and PM Peak Hour Flow Diagrams All Vehicles Except Bicycles



## Campeau Drive & Earl of March Sec. School Exit Kanata, ON

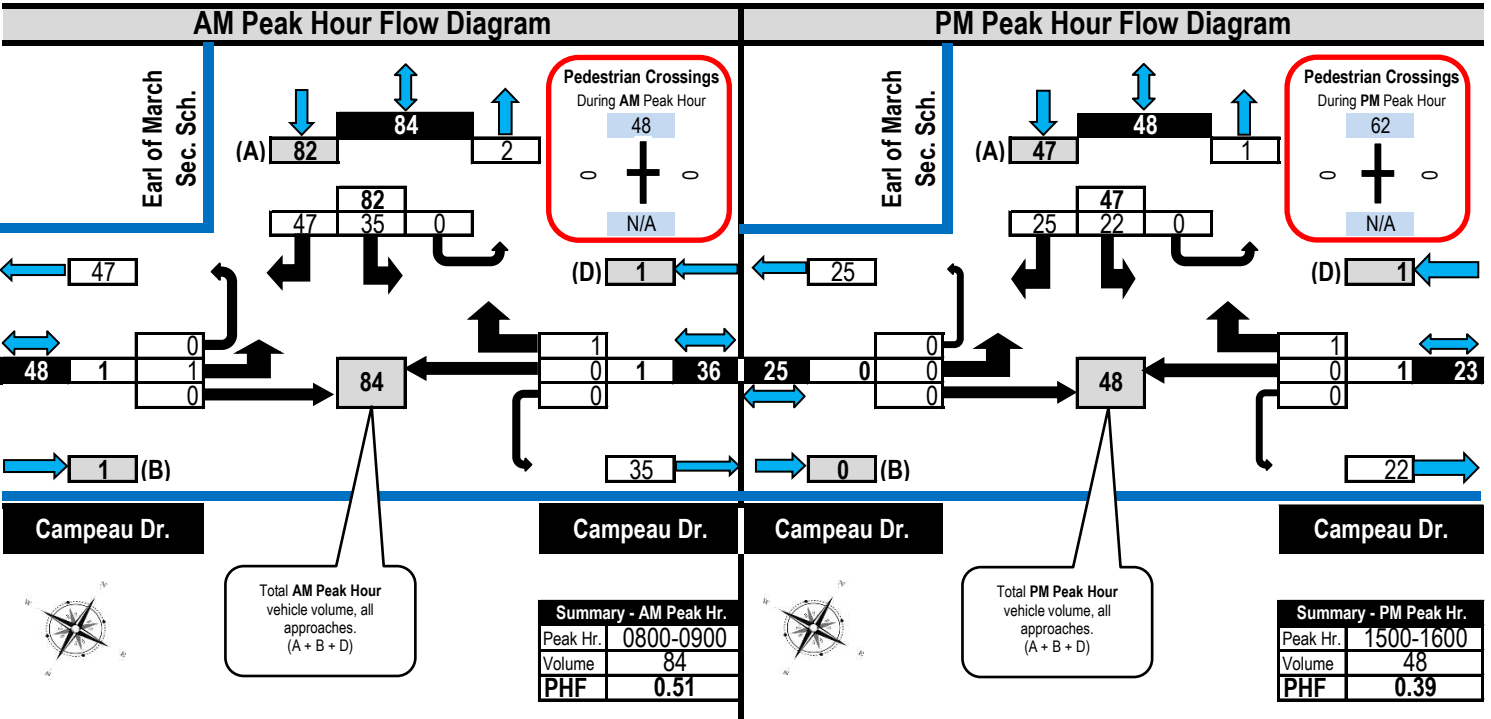
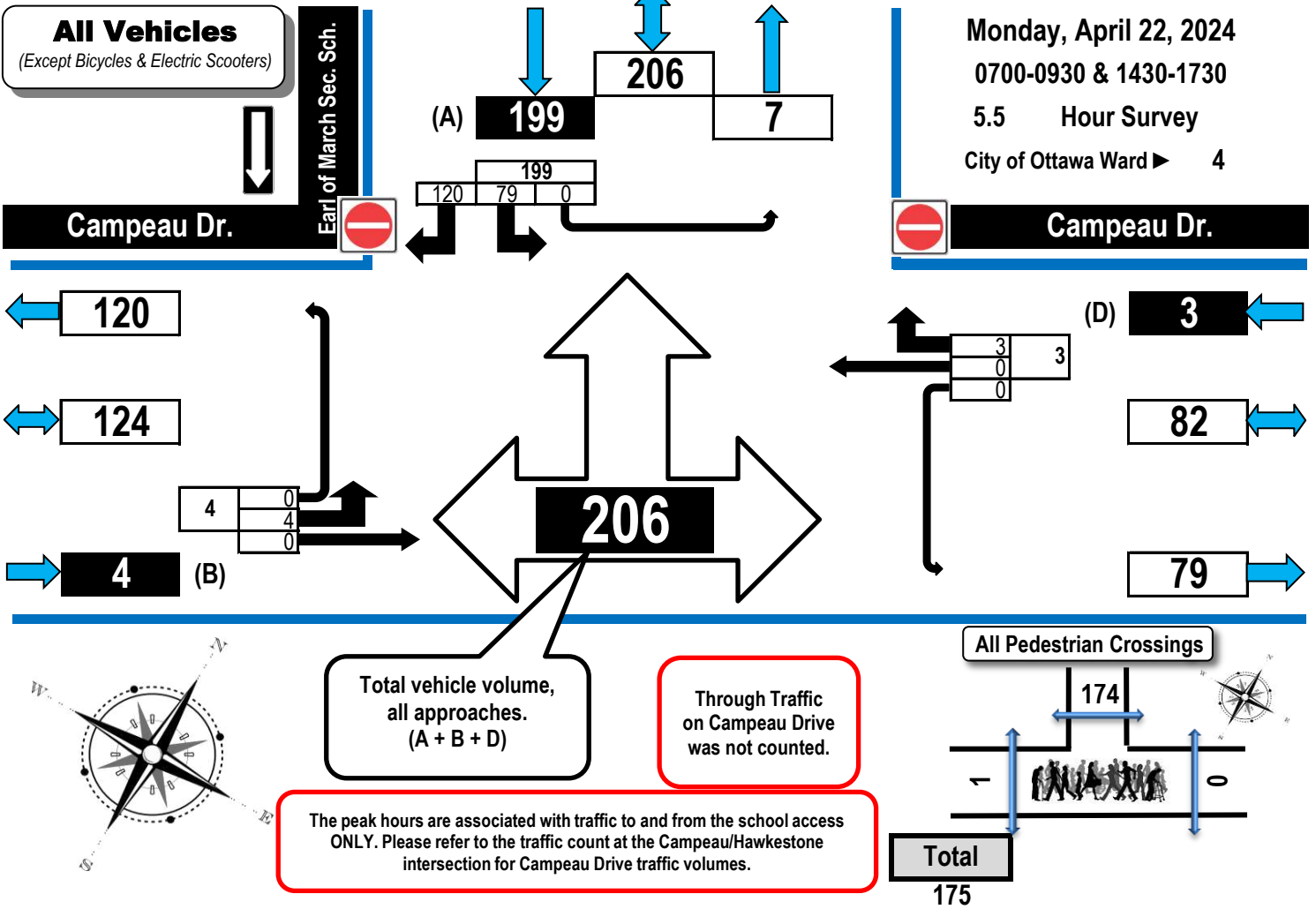



# Turning Movement Count Heavy Vehicle Summary (FHWA Class 4-13) Flow Diagram



## Campeau Drive & Earl of March Sec. School Exit Kanata, ON

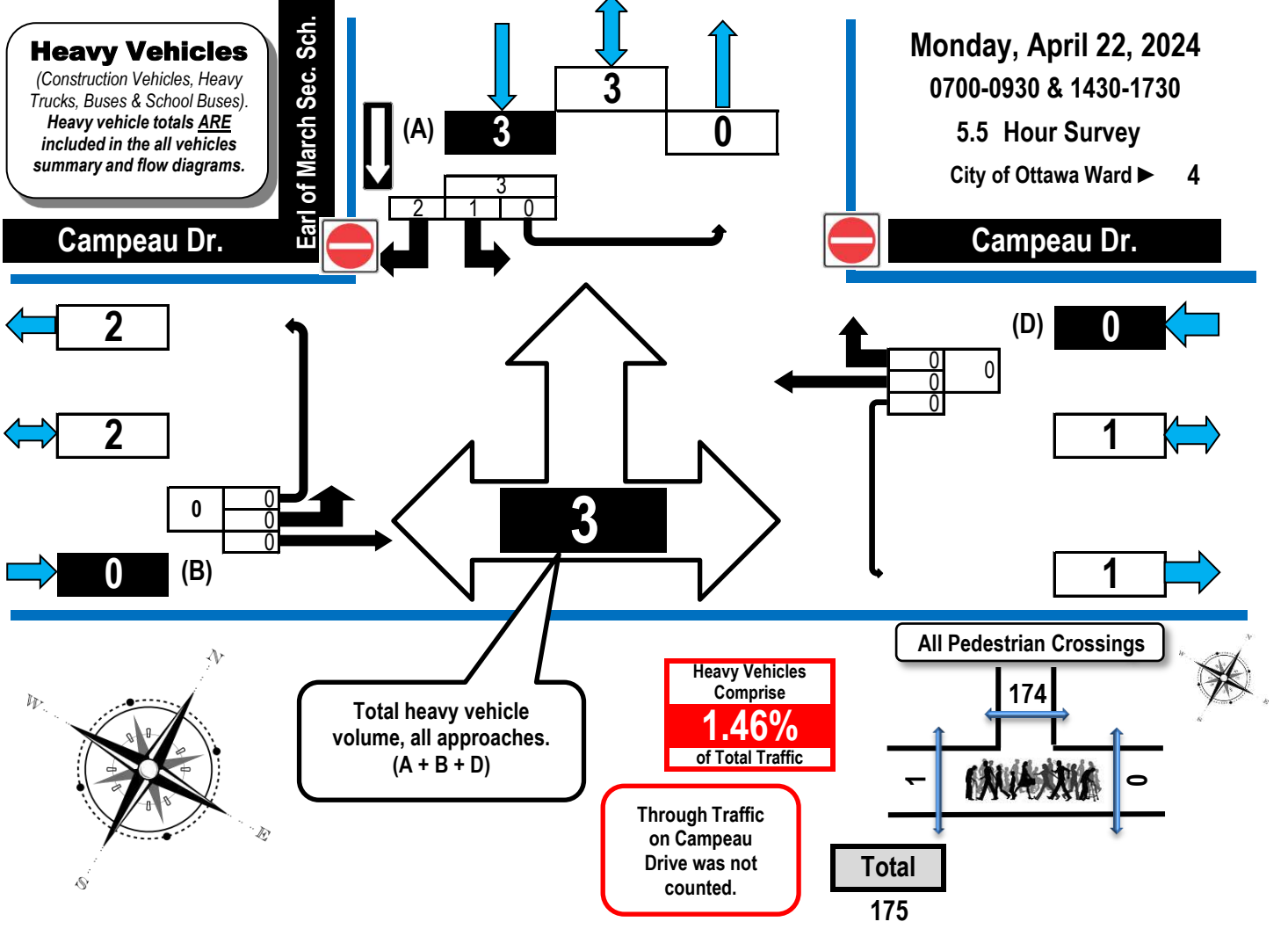

Campeau Dr.	Campeau Dr.	N/A	Earl of March Sec. Sch.
Eastbound	Westbound	Northbound	Southbound

Time Period	LT	ST	RT	UT	EB Tot	LT	ST	RT	UT	WB Tot	LT	ST	RT	UT	NB Tot	LT	ST	RT	UT	SB Tot	GR Tot
0700-0800	0	0		0	0		0	0	0	0						0		0	0	0	0
0800-0900	0	0		0	0		0	0	0	0						1		1	0	2	2
0900-0930	0	0		0	0		0	0	0	0						0		0	0	0	0
1430-1500	0	0		0	0		0	0	0	0						0		0	0	0	0
1500-1600	0	0		0	0		0	0	0	0						0		1	0	1	1
1600-1700	0	0		0	0		0	0	0	0						0		0	0	0	0
1700-1730	0	0		0	0		0	0	0	0						0		0	0	0	0
<b>Totals</b>	<b>0</b>	<b>0</b>		<b>0</b>	<b>0</b>		<b>0</b>	<b>0</b>	<b>0</b>	<b>0</b>						<b>1</b>		<b>2</b>	<b>0</b>	<b>3</b>	<b>3</b>



# Turning Movement Count All Buses Summary (FHWA Class 4 ONLY) Flow Diagram



## Campeau Drive & Earl of March Sec. School Exit Kanata, ON

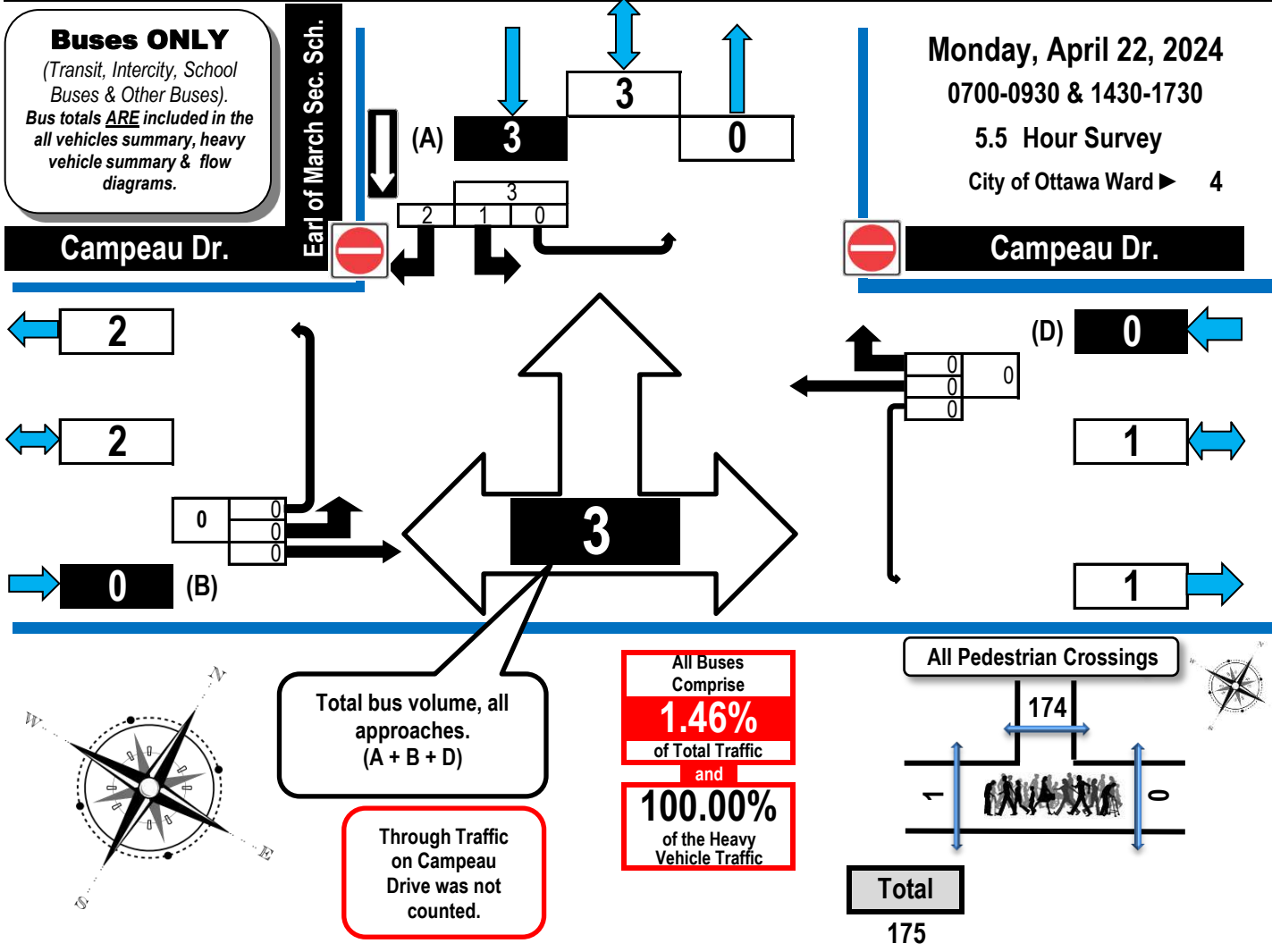

Time Period	Campeau Dr. Eastbound					Campeau Dr. Westbound					N/A Northbound					Earl of March Sec. Sch. Southbound					GR Tot
	LT	ST	RT	UT	EB Tot	LT	ST	RT	UT	WB Tot	LT	ST	RT	UT	NB Tot	LT	ST	RT	UT	SB Tot	
0700-0800	0	0		0	0		0	0	0	0						0		0	0	0	0
0800-0900	0	0		0	0		0	0	0	0						1		1	0	2	2
0900-0930	0	0		0	0		0	0	0	0						0		0	0	0	0
1430-1500	0	0		0	0		0	0	0	0						0		0	0	0	0
1500-1600	0	0		0	0		0	0	0	0						0		1	0	1	1
1600-1700	0	0		0	0		0	0	0	0						0		0	0	0	0
1700-1730	0	0		0	0		0	0	0	0						0		0	0	0	0
<b>Totals</b>	<b>0</b>	<b>0</b>		<b>0</b>	<b>0</b>		<b>0</b>	<b>0</b>	<b>0</b>	<b>0</b>						<b>1</b>		<b>2</b>	<b>0</b>	<b>3</b>	<b>3</b>



# Turning Movement Count Bicycle Summary Flow Diagram



## Campeau Drive & Earl of March Sec. School Exit Kanata, ON

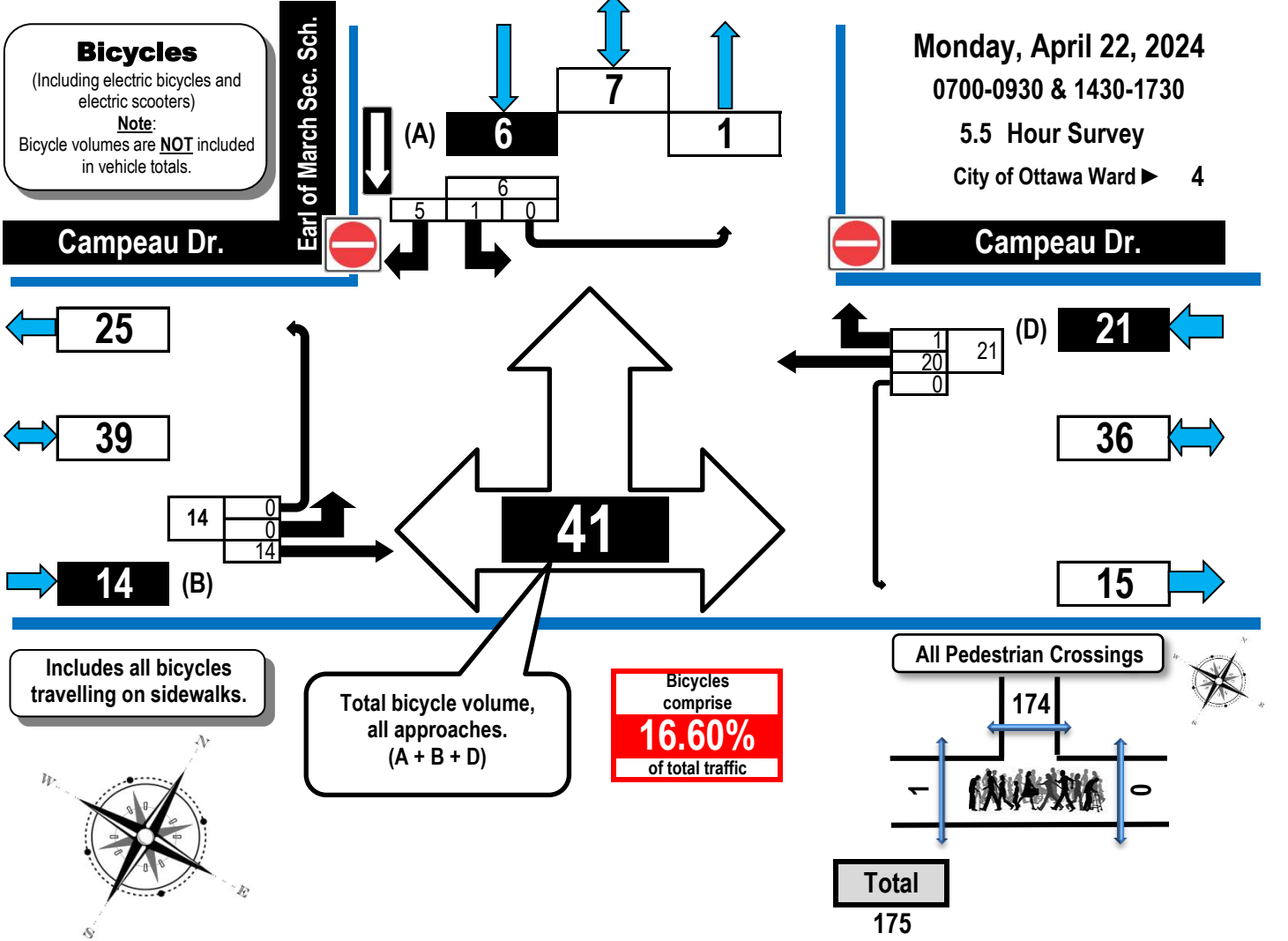

Time Period	Campeau Dr. Eastbound					Campeau Dr. Westbound					N/A Northbound					Earl of March Sec. Sch. Southbound					GR Tot
	LT	ST	RT	UT	EB Tot	LT	ST	RT	UT	WB Tot	LT	ST	RT	UT	NB Tot	LT	ST	RT	UT	SB Tot	
0700-0800	0	5		0	5		2	1	0	3						0		0	0	0	8
0800-0900	0	3		0	3		4	0	0	4						0		0	0	0	7
0900-0930	0	0		0	0		1	0	0	1						0		0	0	0	1
1430-1500	0	0		0	0		0	0	0	0						0		2	0	2	2
1500-1600	0	1		0	1		1	0	0	1						0		1	0	1	3
1600-1700	0	3		0	3		4	0	0	4						0		2	0	2	9
1700-1730	0	2		0	2		8	0	0	8						1		0	0	1	11
<b>Totals</b>	<b>0</b>	<b>14</b>		<b>0</b>	<b>14</b>		<b>20</b>	<b>1</b>	<b>0</b>	<b>21</b>						<b>1</b>		<b>5</b>	<b>0</b>	<b>6</b>	<b>41</b>



# Turning Movement Count Pedestrian Crossings Summary and Flow Diagram



## Campeau Drive & Earl of March Sec. School Exit Kanata, ON

### Pedestrian Crossings

**Monday, April 22, 2024**

0700-0930 & 1430-1730

5.5 Hour Survey

City of Ottawa Ward ► 4

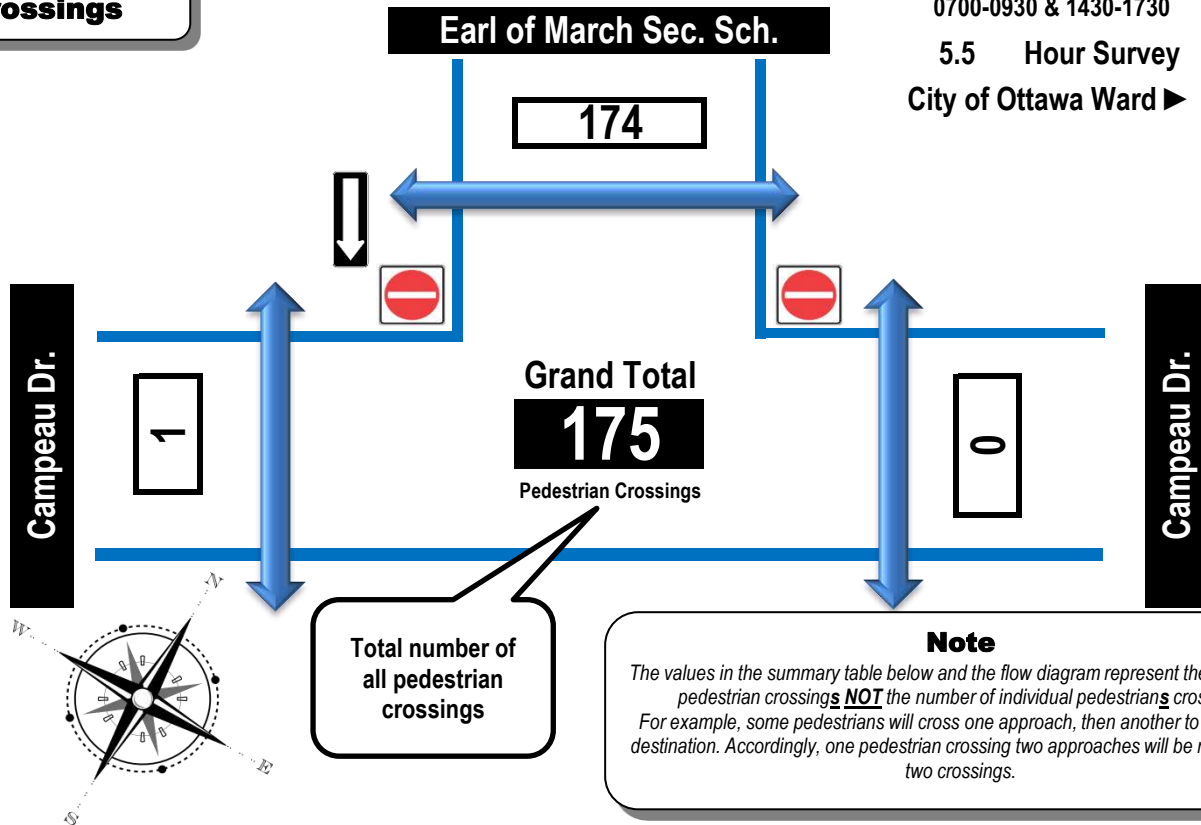

Time Period	West Side Crossing Campeau Dr.	East Side Crossing Campeau Dr.	Street Total	South Side Crossing N/A	North Side Crossing Earl of March Sec. Sch.	Street Total	Grand Total
0700-0800	0	0	0		5	5	5
0800-0900	0	0	0		48	48	48
0900-0930	0	0	0		6	6	6
1430-1500	0	0	0		38	38	38
1500-1600	0	0	0		62	62	62
1600-1700	1	0	1		14	14	15
1700-1730	0	0	0		1	1	1
<b>Totals</b>	<b>1</b>	<b>0</b>	<b>1</b>		<b>174</b>	<b>174</b>	<b>175</b>

**Comments:**

OC Transpo buses and school buses comprise 100% of the heavy vehicle traffic exiting Earl of March Secondary School. Only vehicles exiting the school property are recorded here. Please refer to the traffic count at the intersection of Campeau Drive/Hawkstone Gate intersection for vehicle volumes on Campeau Drive. All bicycle movements and all pedestrian crossings were counted.



# Turning Movement Count

## Summary Report Including AM, OFF Peak and PM Peak Hours Including PHF

All Vehicles Except Bicycles



### Campeau Drive & Earl of March Sec. School Exit Kanata, ON

**Survey Date:** Monday, April 22, 2024      **Start Time:** 0700      **AADT Factor:** 1.0  
**Weather AM:** Sunny -2° C      **Survey Duration:** 5.5 Hrs.      **Survey Hours:** 0700-0930 & 1430-1730  
**Weather PM:** Sunny 8° C      **Surveyor(s):** J. Mousseau

Time Period	Campeau Dr. Eastbound					Campeau Dr. Westbound					N/A Northbound					Earl of March Sec. Sch. Southbound					Street Total	Grand Total	
	LT	ST	RT	UT	E/B Tot	LT	ST	RT	UT	W/B Tot	LT	ST	RT	UT	N/B Tot	LT	ST	RT	UT	S/B Tot			
	0700-0800	2	0	0	0	2	0	0	1	0	1	3	0	0	0	0	0	3	0	1			0
0800-0900	1	0	0	0	1	0	0	1	0	1	2	0	0	0	0	0	35	0	47	0	82	82	84
0900-0930	1	0	0	0	1	0	0	0	0	0	1	0	0	0	0	2	0	3	0	5	5	6	
1430-1500	0	0	0	0	0	0	0	0	0	0	0	0	0	0	0	6	0	21	0	27	27	27	
1500-1600	0	0	0	0	0	0	0	1	0	1	1	0	0	0	0	22	0	25	0	47	47	48	
1600-1700	0	0	0	0	0	0	0	0	0	0	0	0	0	0	0	9	0	15	0	24	24	24	
1700-1730	0	0	0	0	0	0	0	0	0	0	0	0	0	0	0	2	0	8	0	10	10	10	
<b>Totals</b>	<b>4</b>	<b>0</b>	<b>0</b>	<b>0</b>	<b>4</b>	<b>0</b>	<b>0</b>	<b>3</b>	<b>0</b>	<b>3</b>	<b>7</b>	<b>0</b>	<b>0</b>	<b>0</b>	<b>0</b>	<b>79</b>	<b>0</b>	<b>120</b>	<b>0</b>	<b>199</b>	<b>199</b>	<b>206</b>	

**Equivalent 12 & 24-hour Vehicle Volumes Including the Annual Average Daily Traffic (AADT) Factor**  
**Applicable to the Day and Month of the Turning Movement Count**

Average daily 12-hour vehicle volumes. These volumes are calculated by multiplying the 12-hour totals by the AADT factor of: 1.0

AADT 12 Hr	N/A	N/A	N/A	N/A	N/A	N/A	N/A	N/A	N/A	N/A	N/A	N/A	N/A	N/A	N/A	N/A	N/A	N/A	N/A	N/A	N/A	N/A	N/A
------------	-----	-----	-----	-----	-----	-----	-----	-----	-----	-----	-----	-----	-----	-----	-----	-----	-----	-----	-----	-----	-----	-----	-----

24-Hour AADT. These volumes are calculated by multiplying the average daily 12-hour vehicle volumes by the 12 → 24 expansion factor of 1.31

AADT 24 Hr	N/A	N/A	N/A	N/A	N/A	N/A	N/A	N/A	N/A	N/A	N/A	N/A	N/A	N/A	N/A	N/A	N/A	N/A	N/A	N/A	N/A	N/A	N/A
------------	-----	-----	-----	-----	-----	-----	-----	-----	-----	-----	-----	-----	-----	-----	-----	-----	-----	-----	-----	-----	-----	-----	-----

**AADT and Expansion Factors provided by the City of Ottawa**

<b>AM Peak Hour Factor → 0.51</b>											<b>Highest Hourly Vehicle Volume between 0700h &amp; 1000h</b>												
AM Peak Hr	LT	ST	RT	UT	Total	LT	ST	RT	UT	Total	Str. Tot.	LT	ST	RT	UT	Total	LT	ST	RT	UT	Total	Str. Tot.	Gr. Tot.
0800-0900	1	0	0	0	1	0	0	1	0	1	2	0	0	0	0	0	35	0	47	0	82	82	84
<b>OFF Peak Hour Factor → N/A</b>											<b>Highest Hourly Vehicle Volume Between 1000h &amp; 1500h</b>												
OFF Peak Hr	LT	ST	RT	UT	Total	LT	ST	RT	UT	Total	Str. Tot.	LT	ST	RT	UT	Total	LT	ST	RT	UT	Total	Str. Tot.	Gr. Tot.
N/A	N/A	N/A	N/A	N/A	N/A	N/A	N/A	N/A	N/A	N/A	N/A	N/A	N/A	N/A	N/A	N/A	N/A	N/A	N/A	N/A	N/A	N/A	N/A
<b>PM Peak Hour Factor → 0.39</b>											<b>Highest Hourly Vehicle Volume Between 1500h &amp; 1900h</b>												
PM Peak Hr	LT	ST	RT	UT	Total	LT	ST	RT	UT	Total	Str. Tot.	LT	ST	RT	UT	Total	LT	ST	RT	UT	Total	Str. Tot.	Gr. Tot.
1500-1600	0	0	0	0	0	0	0	1	0	1	1	0	0	0	0	0	22	0	25	0	47	47	48

**Comments:**

OC Transpo buses and school buses comprise 100% of the heavy vehicle traffic exiting Earl of March Secondary School. Only vehicles exiting the school property are recorded here. Please refer to the traffic count at the intersection of Campeau Drive/Hawkstone Gate intersection for vehicle volumes on Campeau Drive. All bicycle movements and all pedestrian crossings were counted.

**Notes:**

1. Includes all vehicle types except bicycles and electric scooters.
2. When expansion and AADT factors are applied, the results will differ slightly due to rounding.





# Turning Movement Count

## Summary Report Including AM, OFF Peak and PM Peak Hours Including PHF

All Vehicles Except Bicycles



### Campeau Drive & Hawkstone Gate/Earl of March Sec. School Kanata, ON

**Survey Date:** Monday, April 22, 2024      **Start Time:** 0700      **AADT Factor:** 1.0  
**Weather AM:** Sunny -2° C      **Survey Duration:** 5.5 Hrs.      **Survey Hours:** 0700-0930 & 1430-1730  
**Weather PM:** Sunny 8° C      **Surveyor(s):** J. Mousseau & S. Merrett

Time Period	Campeau Dr. Eastbound					Campeau Dr. Westbound					Hawkstone Gate Northbound					Earl of March Sec. Sch. Southbound					Street Total	Grand Total	
	LT	ST	RT	UT	E/B Tot	LT	ST	RT	UT	W/B Tot	LT	ST	RT	UT	N/B Tot	LT	ST	RT	UT	S/B Tot			
	0700-0800	12	210	1	0	223	2	119	19	0	140	363	1	1	7	0	9	11	0	6			0
0800-0900	119	279	20	0	418	19	261	102	0	382	800	20	5	28	0	53	87	9	96	0	192	245	1045
0900-0930	12	105	2	0	119	2	130	26	0	158	277	4	0	4	0	8	11	0	8	0	19	27	304
1430-1500	38	132	7	0	177	11	175	35	0	221	398	4	1	5	0	10	33	0	24	0	57	67	465
1500-1600	50	302	14	0	366	13	363	95	0	471	837	11	0	16	0	27	102	1	72	0	175	202	1039
1600-1700	55	280	12	0	347	15	399	74	0	488	835	9	2	3	0	14	56	1	62	0	119	133	968
1700-1730	23	131	5	0	159	5	211	55	0	271	430	2	0	2	0	4	38	1	20	0	59	63	493
<b>Totals</b>	<b>309</b>	<b>1439</b>	<b>61</b>	<b>0</b>	<b>1809</b>	<b>67</b>	<b>1658</b>	<b>406</b>	<b>0</b>	<b>2131</b>	<b>3940</b>	<b>51</b>	<b>9</b>	<b>65</b>	<b>0</b>	<b>125</b>	<b>338</b>	<b>12</b>	<b>288</b>	<b>0</b>	<b>638</b>	<b>763</b>	<b>4703</b>

**Equivalent 12 & 24-hour Vehicle Volumes Including the Annual Average Daily Traffic (AADT) Factor**  
**Applicable to the Day and Month of the Turning Movement Count**

Average daily 12-hour vehicle volumes. These volumes are calculated by multiplying the 12-hour totals by the AADT factor of: 1.0

AADT 12 Hr	N/A	N/A	N/A	N/A	N/A	N/A	N/A	N/A	N/A	N/A	N/A	N/A	N/A	N/A	N/A	N/A	N/A	N/A	N/A	N/A	N/A	N/A	N/A
------------	-----	-----	-----	-----	-----	-----	-----	-----	-----	-----	-----	-----	-----	-----	-----	-----	-----	-----	-----	-----	-----	-----	-----

24-Hour AADT. These volumes are calculated by multiplying the average daily 12-hour vehicle volumes by the 12 → 24 expansion factor of 1.31

AADT 24 Hr	N/A	N/A	N/A	N/A	N/A	N/A	N/A	N/A	N/A	N/A	N/A	N/A	N/A	N/A	N/A	N/A	N/A	N/A	N/A	N/A	N/A	N/A	N/A
------------	-----	-----	-----	-----	-----	-----	-----	-----	-----	-----	-----	-----	-----	-----	-----	-----	-----	-----	-----	-----	-----	-----	-----

**AADT and Expansion Factors provided by the City of Ottawa**

<b>AM Peak Hour Factor → 0.73</b>											<b>Highest Hourly Vehicle Volume between 0700h &amp; 1000h</b>												
<b>AM Peak Hr</b>	LT	ST	RT	UT	Total	LT	ST	RT	UT	Total	Str. Tot.	LT	ST	RT	UT	Total	LT	ST	RT	UT	Total	Str. Tot.	Gr. Tot.
0800-0900	119	279	20	0	418	19	261	102	0	382	800	20	5	28	0	53	87	9	96	0	192	245	1045
<b>OFF Peak Hour Factor → N/A</b>											<b>Highest Hourly Vehicle Volume Between 1000h &amp; 1500h</b>												
<b>OFF Peak Hr</b>	LT	ST	RT	UT	Total	LT	ST	RT	UT	Total	Str. Tot.	LT	ST	RT	UT	Total	LT	ST	RT	UT	Total	Str. Tot.	Gr. Tot.
N/A	N/A	N/A	N/A	N/A	N/A	N/A	N/A	N/A	N/A	N/A	N/A	N/A	N/A	N/A	N/A	N/A	N/A	N/A	N/A	N/A	N/A	N/A	N/A
<b>PM Peak Hour Factor → 0.77</b>											<b>Highest Hourly Vehicle Volume Between 1500h &amp; 1900h</b>												
<b>PM Peak Hr</b>	LT	ST	RT	UT	Total	LT	ST	RT	UT	Total	Str. Tot.	LT	ST	RT	UT	Total	LT	ST	RT	UT	Total	Str. Tot.	Gr. Tot.
1500-1600	50	302	14	0	366	13	363	95	0	471	837	11	0	16	0	27	102	1	72	0	175	202	1039

**Comments:**

OC Transpo buses, Para Transpo buses and school buses comprise 61.48% of the heavy vehicle traffic.

**Notes:**

1. Includes all vehicle types except bicycles and electric scooters.
2. When expansion and AADT factors are applied, the results will differ slightly due to rounding.



# Turning Movement Count Summary, AM and PM Peak Hour Flow Diagrams All Vehicles Except Bicycles



**Campeau Drive & Hawkstone Gate/Earl of March Sec. School**

**Kanata, ON**

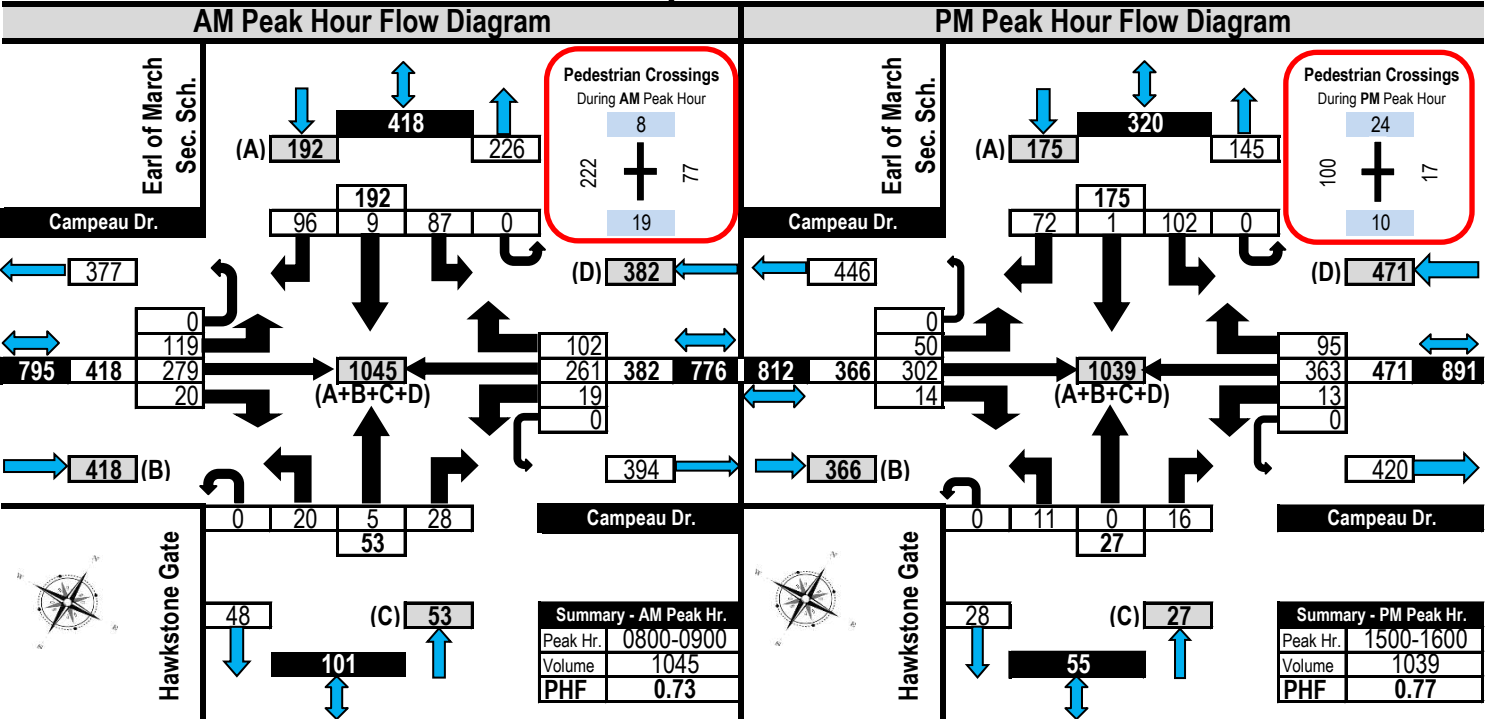
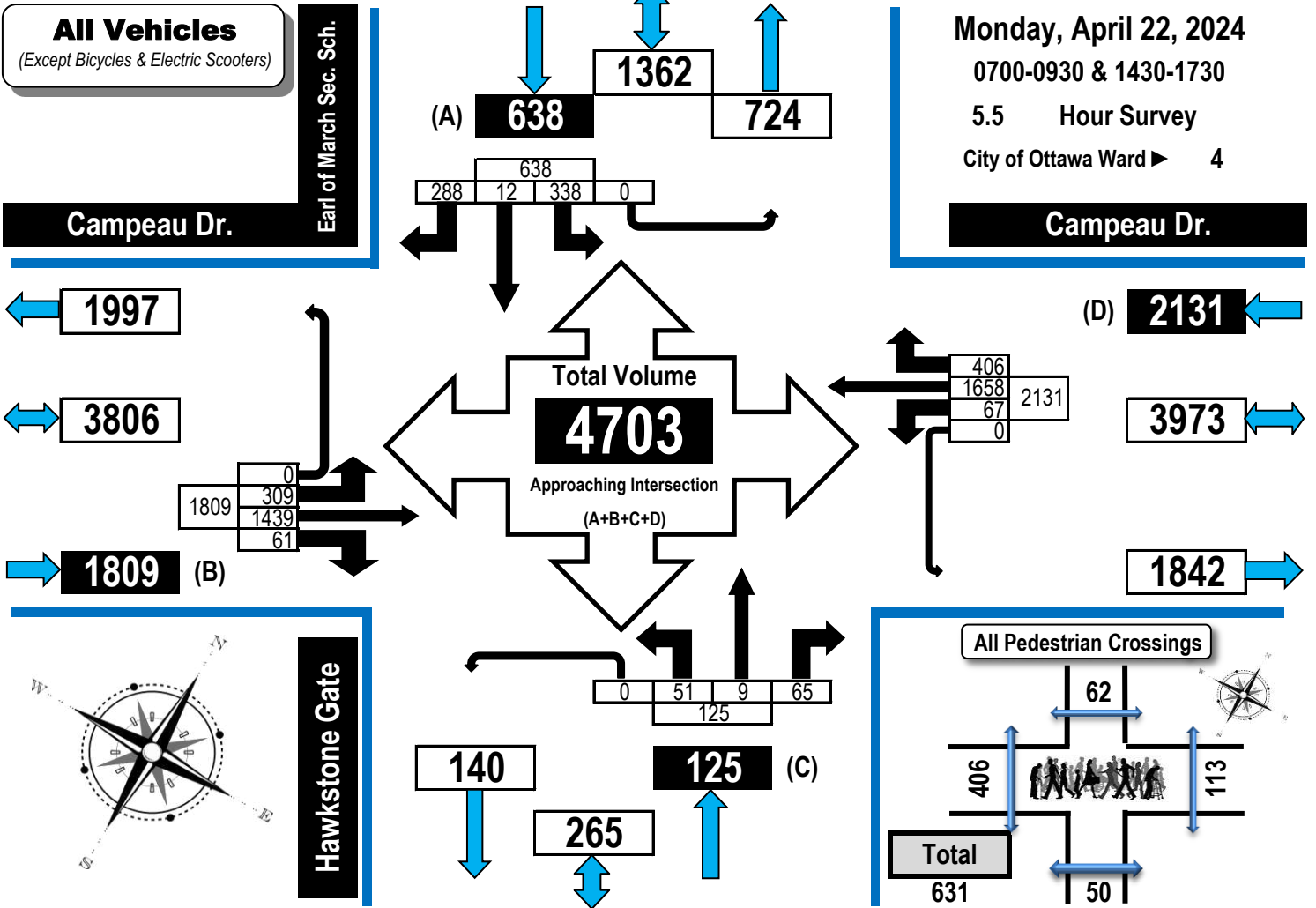



# Turning Movement Count Heavy Vehicle Summary (FHWA Class 4-13) Flow Diagram



## Campeau Drive & Hawkstone Gate/Earl of March Sec. School Kanata, ON

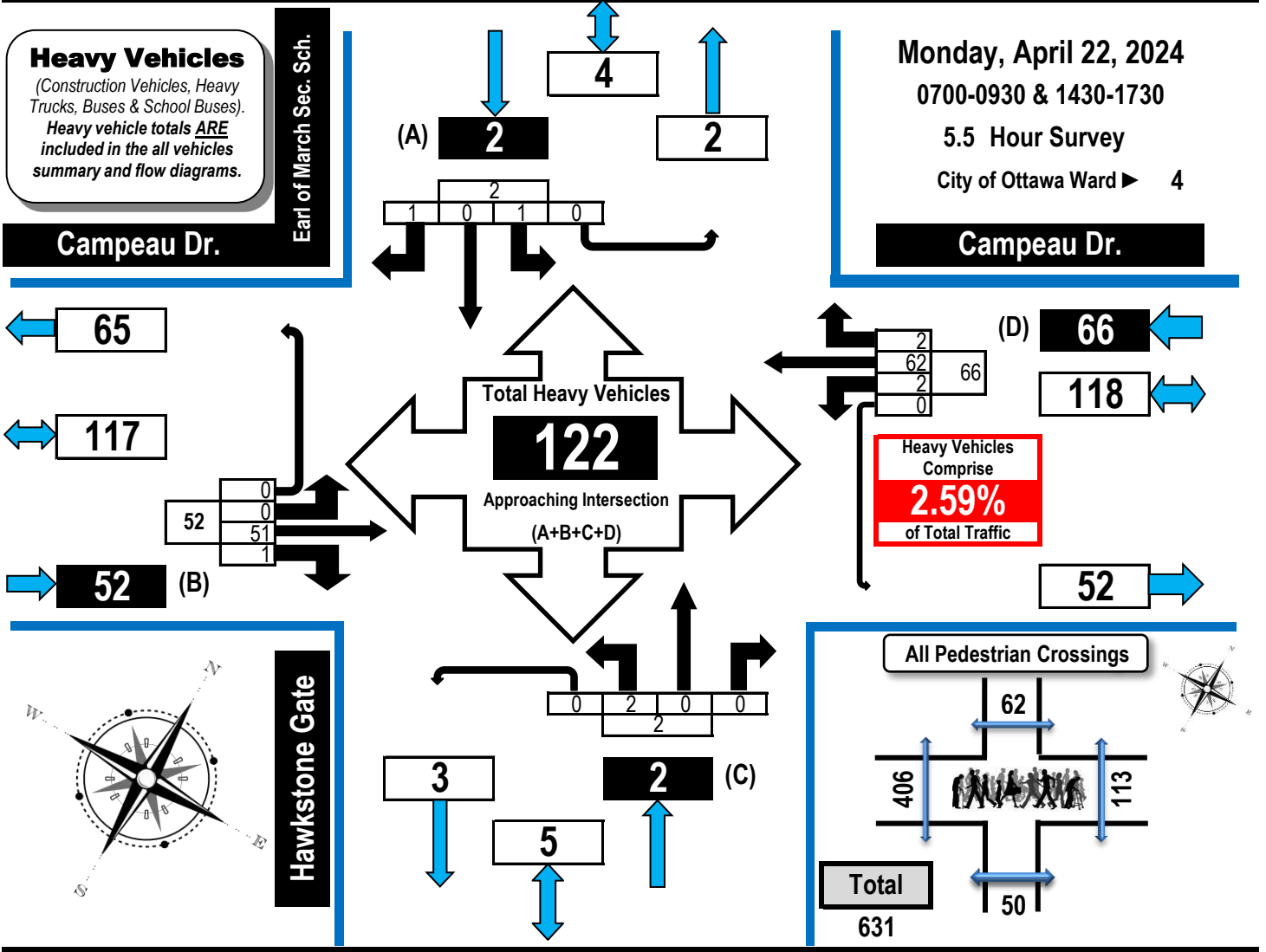

Time Period	Campeau Dr. Eastbound					Campeau Dr. Westbound					Hawkstone Gate Northbound					Earl of March Sec. Sch. Southbound					GR Tot
	LT	ST	RT	UT	EB Tot	LT	ST	RT	UT	WB Tot	LT	ST	RT	UT	NB Tot	LT	ST	RT	UT	SB Tot	
0700-0800	0	8	0	0	8	0	8	0	0	8	0	0	0	0	0	0	0	0	0	0	16
0800-0900	0	14	1	0	15	1	14	1	0	16	0	0	0	0	0	0	0	0	0	0	31
0900-0930	0	2	0	0	2	0	9	0	0	9	0	0	0	0	0	0	0	0	0	0	11
1430-1500	0	2	0	0	2	0	2	0	0	2	1	0	0	0	1	1	0	0	0	1	6
1500-1600	0	14	0	0	14	0	18	0	0	18	0	0	0	0	0	0	0	0	0	0	32
1600-1700	0	7	0	0	7	1	9	1	0	11	1	0	0	0	1	0	0	1	0	1	20
1700-1730	0	4	0	0	4	0	2	0	0	2	0	0	0	0	0	0	0	0	0	0	6
<b>Totals</b>	<b>0</b>	<b>51</b>	<b>1</b>	<b>0</b>	<b>52</b>	<b>2</b>	<b>62</b>	<b>2</b>	<b>0</b>	<b>66</b>	<b>2</b>	<b>0</b>	<b>0</b>	<b>0</b>	<b>2</b>	<b>1</b>	<b>0</b>	<b>1</b>	<b>0</b>	<b>2</b>	<b>122</b>



# Turning Movement Count All Buses Summary (FHWA Class 4 ONLY) Flow Diagram



## Campeau Drive & Hawkstone Gate/Earl of March Sec. School Kanata, ON

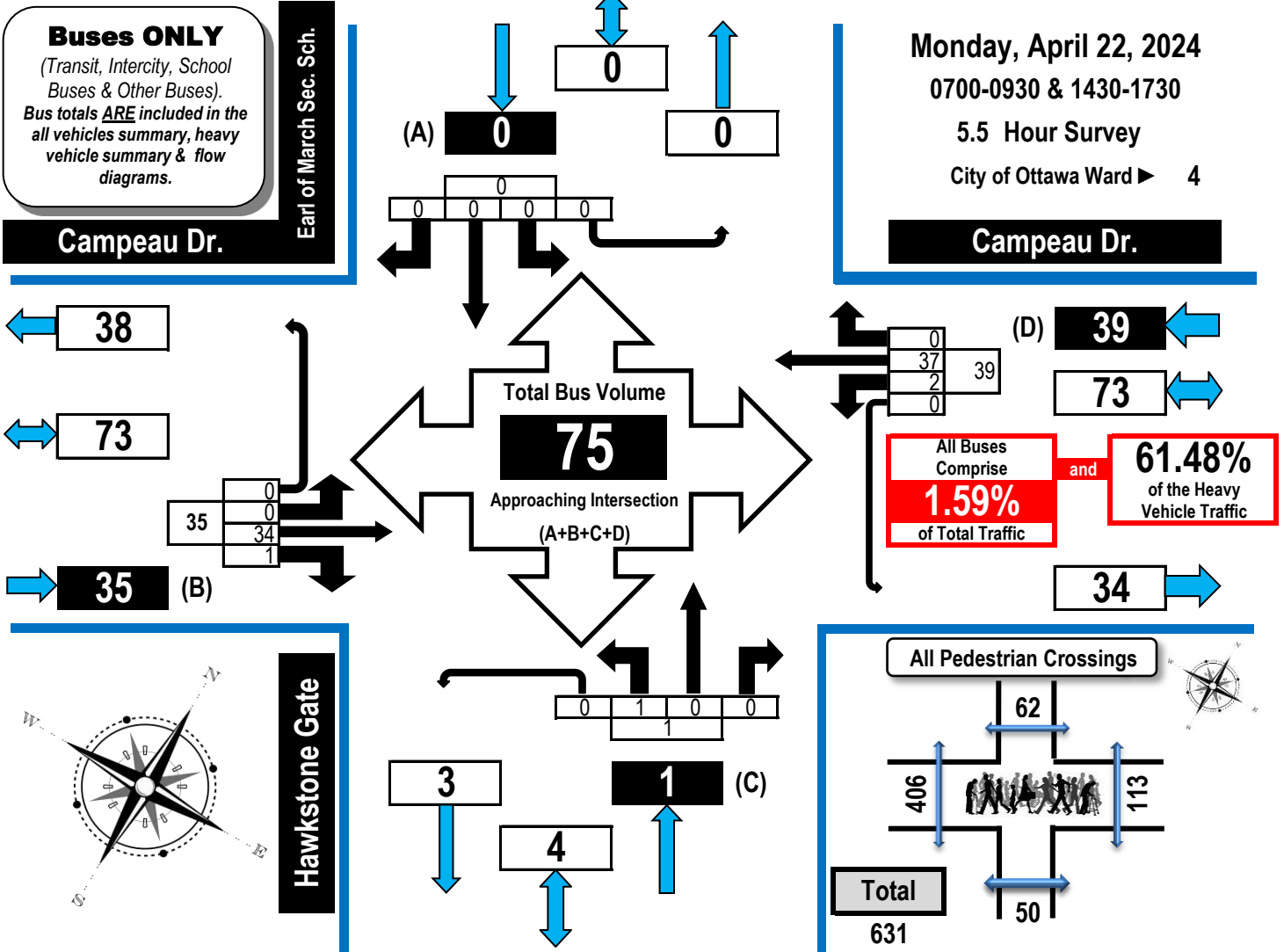

Time Period	Campeau Dr. Eastbound					Campeau Dr. Westbound					Hawkstone Gate Northbound					Earl of March Sec. Sch. Southbound					GR Tot
	LT	ST	RT	UT	EB Tot	LT	ST	RT	UT	WB Tot	LT	ST	RT	UT	NB Tot	LT	ST	RT	UT	SB Tot	
0700-0800	0	5	0	0	5	0	4	0	0	4	0	0	0	0	0	0	0	0	0	0	9
0800-0900	0	10	1	0	11	1	9	0	0	10	0	0	0	0	0	0	0	0	0	0	21
0900-0930	0	1	0	0	1	0	3	0	0	3	0	0	0	0	0	0	0	0	0	0	4
1430-1500	0	2	0	0	2	0	1	0	0	1	0	0	0	0	0	0	0	0	0	0	3
1500-1600	0	7	0	0	7	0	13	0	0	13	0	0	0	0	0	0	0	0	0	0	20
1600-1700	0	6	0	0	6	1	5	0	0	6	1	0	0	0	1	0	0	0	0	0	13
1700-1730	0	3	0	0	3	0	2	0	0	2	0	0	0	0	0	0	0	0	0	0	5
<b>Totals</b>	<b>0</b>	<b>34</b>	<b>1</b>	<b>0</b>	<b>35</b>	<b>2</b>	<b>37</b>	<b>0</b>	<b>0</b>	<b>39</b>	<b>1</b>	<b>0</b>	<b>0</b>	<b>0</b>	<b>1</b>	<b>0</b>	<b>0</b>	<b>0</b>	<b>0</b>	<b>0</b>	<b>75</b>



# Turning Movement Count Bicycle Summary Flow Diagram



## Campeau Drive & Hawkstone Gate/Earl of March Sec. School Kanata, ON

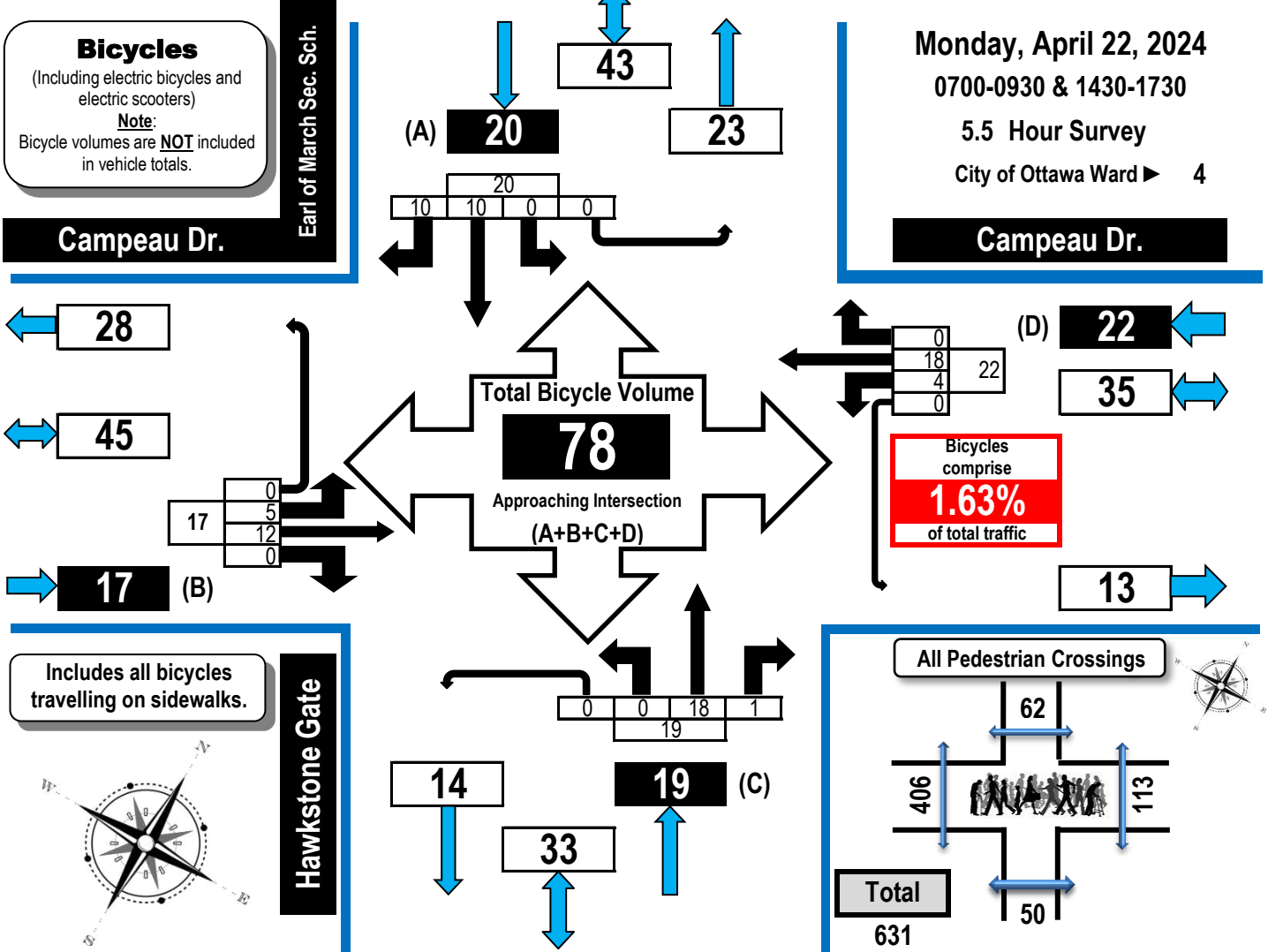

Campeau Dr. Eastbound	Campeau Dr. Westbound	Hawkstone Gate Northbound	Earl of March Sec. Sch. Southbound
--------------------------	--------------------------	------------------------------	---------------------------------------

Time Period	Campeau Dr. Eastbound					Campeau Dr. Westbound					Hawkstone Gate Northbound					Earl of March Sec. Sch. Southbound					GR Tot
	LT	ST	RT	UT	EB Tot	LT	ST	RT	UT	WB Tot	LT	ST	RT	UT	NB Tot	LT	ST	RT	UT	SB Tot	
0700-0800	0	5	0	0	5	0	2	0	0	2	0	2	0	0	2	0	1	0	0	1	10
0800-0900	4	3	0	0	7	0	1	0	0	1	0	12	1	0	13	0	1	0	0	1	22
0900-0930	1	0	0	0	1	0	1	0	0	1	0	0	0	0	0	0	0	0	0	0	2
1430-1500	0	0	0	0	0	1	1	0	0	2	0	1	0	0	1	0	3	3	0	6	9
1500-1600	0	1	0	0	1	0	2	0	0	2	0	0	0	0	0	0	4	6	0	10	13
1600-1700	0	2	0	0	2	1	5	0	0	6	0	3	0	0	3	0	1	1	0	2	13
1700-1730	0	1	0	0	1	2	6	0	0	8	0	0	0	0	0	0	0	0	0	0	9
<b>Totals</b>	<b>5</b>	<b>12</b>	<b>0</b>	<b>0</b>	<b>17</b>	<b>4</b>	<b>18</b>	<b>0</b>	<b>0</b>	<b>22</b>	<b>0</b>	<b>18</b>	<b>1</b>	<b>0</b>	<b>19</b>	<b>0</b>	<b>10</b>	<b>10</b>	<b>0</b>	<b>20</b>	<b>78</b>



# Turning Movement Count Pedestrian Crossings Summary and Flow Diagram



**Campeau Drive & Hawkstone Gate/Earl of March Sec. School** **Kanata, ON**

**Pedestrian Crossings**

**Monday, April 22, 2024**

0700-0930 & 1430-1730

5.5 Hour Survey

City of Ottawa Ward ► 4

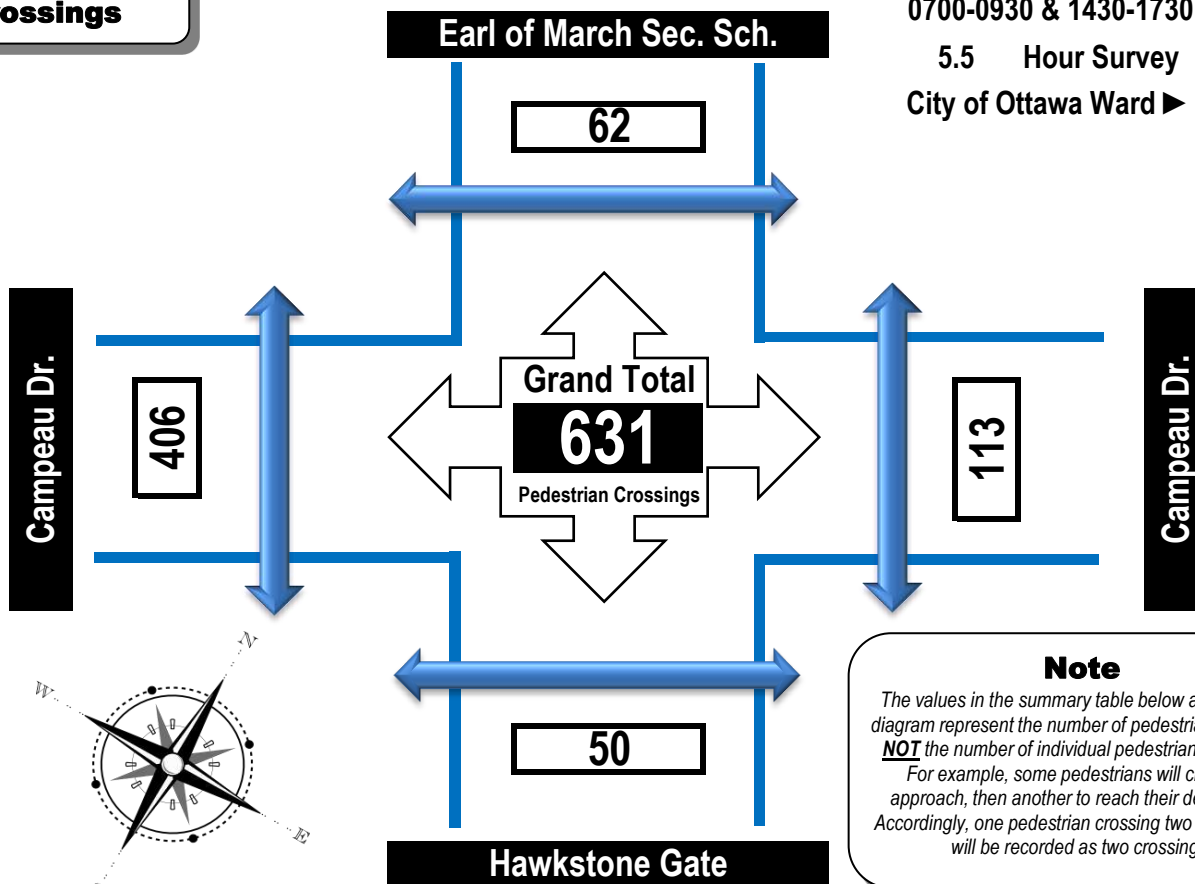

**Note**  
The values in the summary table below and the flow diagram represent the number of pedestrian crossings NOT the number of individual pedestrians crossing. For example, some pedestrians will cross one approach, then another to reach their destination. Accordingly, one pedestrian crossing two approaches will be recorded as two crossings.

Time Period	West Side Crossing Campeau Dr.	East Side Crossing Campeau Dr.	Street Total	South Side Crossing Hawkstone Gate	North Side Crossing Earl of March Sec. Sch.	Street Total	Grand Total
0700-0800	12	0	12	3	5	8	20
0800-0900	222	77	299	19	8	27	326
0900-0930	3	1	4	0	8	8	12
1430-1500	45	9	54	5	1	6	60
1500-1600	100	17	117	10	24	34	151
1600-1700	20	7	27	8	13	21	48
1700-1730	4	2	6	5	3	8	14
<b>Totals</b>	<b>406</b>	<b>113</b>	<b>519</b>	<b>50</b>	<b>62</b>	<b>112</b>	<b>631</b>

**Comments:**

OC Transpo buses, Para Transpo buses and school buses comprise 61.48% of the heavy vehicle traffic.

## Turning Movement Count - Study Results

### CAMPEAU DR @ TERON RD/COLCHESTER SQ

**Survey Date:** Tuesday, February 13, 2024

**WO No:** 41688

**Start Time:** 07:00

**Device:** Miovision

### AM Period Peak Hour Diagram

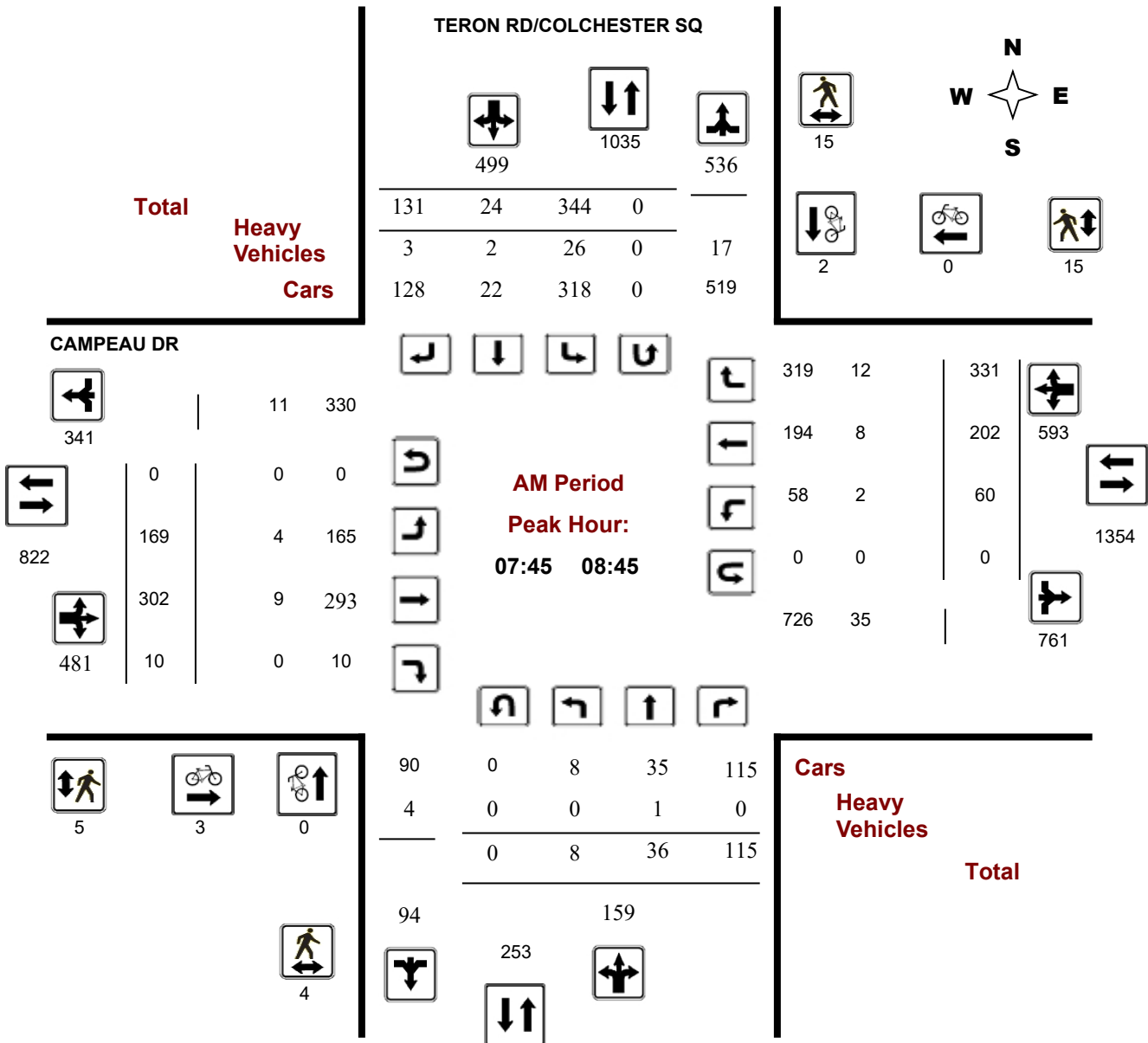

## Turning Movement Count - Study Results

### CAMPEAU DR @ TERON RD/COLCHESTER SQ

**Survey Date:** Tuesday, February 13, 2024

**WO No:** 41688

**Start Time:** 07:00

**Device:** Miovision

### PM Period Peak Hour Diagram

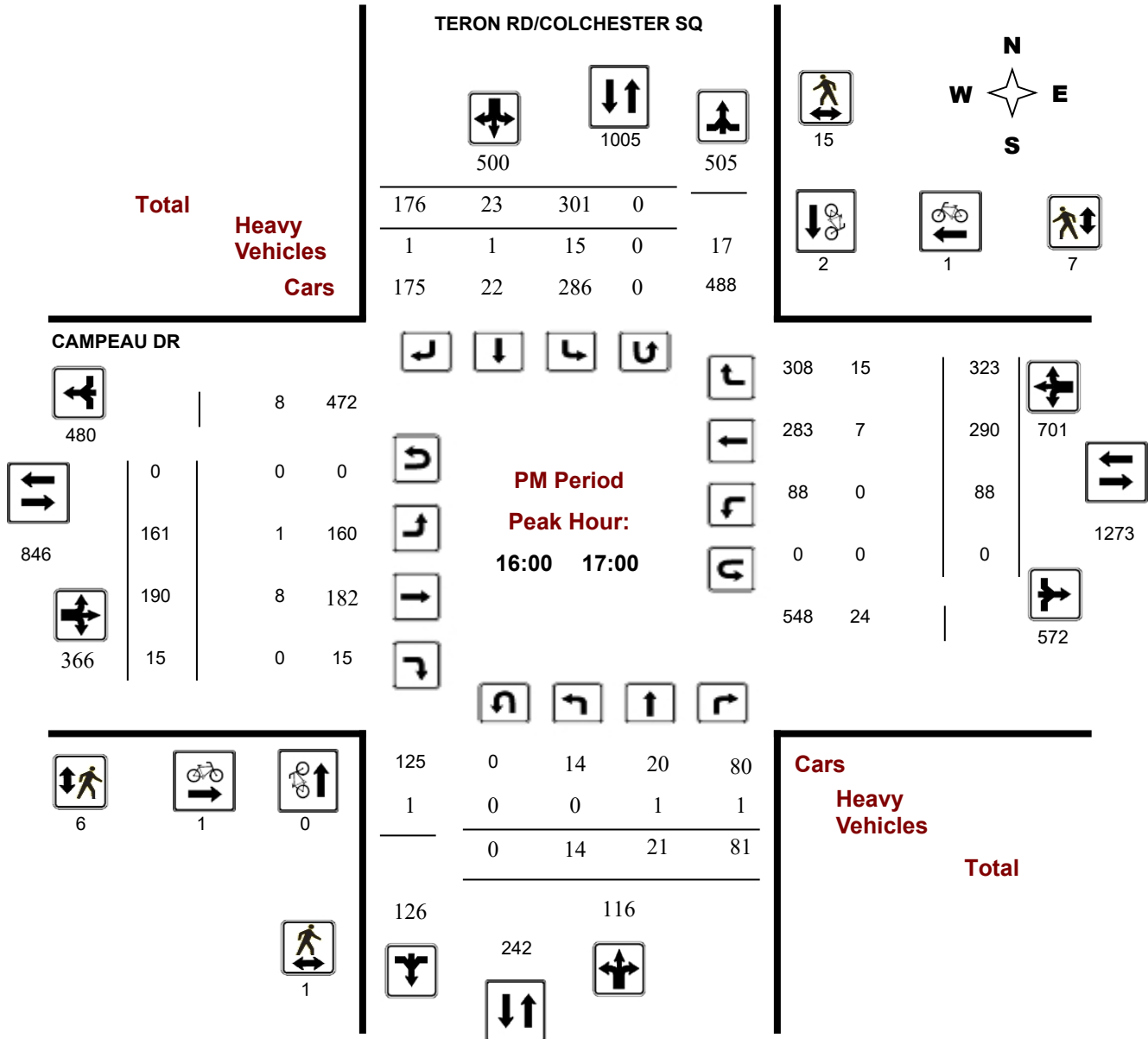





# Turning Movement Count

## Summary Report Including AM, OFF Peak and PM Peak Hours Including PHF

All Vehicles Except Bicycles



### Earl of March Secondary School and The Parkway Kanata, ON

**Survey Date:** Monday, April 22, 2024      **Start Time:** 0700      **AADT Factor:** 1.0  
**Weather AM:** Sunny -2° C      **Survey Duration:** 5.5 Hrs.      **Survey Hours:** 0700-0930 & 1430-1730  
**Weather PM:** Sunny 8° C      **Surveyor(s):** J. Mousseau

Time Period	The Parkway Eastbound					The Parkway Westbound					Earl of March Sec. Sch. Northbound					Pathway Southbound					Street Total	Grand Total	
	LT	ST	RT	UT	E/B Tot	LT	ST	RT	UT	W/B Tot	LT	ST	RT	UT	N/B Tot	LT	ST	RT	UT	S/B Tot			
	0700-0800	0	46	2	0	48	28	65	0	0	93	141	0	0	5	0	5	0	0	0			0
0800-0900	0	67	143	0	210	229	40	0	0	269	479	24	0	129	0	153	0	0	0	0	0	153	632
0900-0930	0	24	3	0	27	8	19	0	0	27	54	2	0	5	0	7	0	0	0	0	0	7	61
1430-1500	0	41	20	0	61	54	17	0	0	71	132	16	0	48	0	64	0	0	0	0	0	64	196
1500-1600	0	56	14	0	70	41	49	0	0	90	160	16	0	82	0	98	0	0	0	0	0	98	258
1600-1700	0	62	8	1	71	19	71	0	0	90	161	13	0	25	0	38	0	0	0	0	0	38	199
1700-1730	0	24	2	0	26	4	30	0	0	34	60	1	0	3	0	4	0	0	0	0	0	4	64
<b>Totals</b>	<b>0</b>	<b>320</b>	<b>192</b>	<b>1</b>	<b>513</b>	<b>383</b>	<b>291</b>	<b>0</b>	<b>0</b>	<b>674</b>	<b>1187</b>	<b>72</b>	<b>0</b>	<b>297</b>	<b>0</b>	<b>369</b>	<b>0</b>	<b>0</b>	<b>0</b>	<b>0</b>	<b>0</b>	<b>369</b>	<b>1556</b>

**Equivalent 12 & 24-hour Vehicle Volumes Including the Annual Average Daily Traffic (AADT) Factor**  
**Applicable to the Day and Month of the Turning Movement Count**

Average daily 12-hour vehicle volumes. These volumes are calculated by multiplying the 12-hour totals by the AADT factor of: 1.0

AADT 12 Hr	N/A	N/A	N/A	N/A	N/A	N/A	N/A	N/A	N/A	N/A	N/A	N/A	N/A	N/A	N/A	N/A	N/A	N/A	N/A	N/A	N/A	N/A	N/A
------------	-----	-----	-----	-----	-----	-----	-----	-----	-----	-----	-----	-----	-----	-----	-----	-----	-----	-----	-----	-----	-----	-----	-----

24-Hour AADT. These volumes are calculated by multiplying the average daily 12-hour vehicle volumes by the 12 → 24 expansion factor of 1.31

AADT 24 Hr	N/A	N/A	N/A	N/A	N/A	N/A	N/A	N/A	N/A	N/A	N/A	N/A	N/A	N/A	N/A	N/A	N/A	N/A	N/A	N/A	N/A	N/A	N/A
------------	-----	-----	-----	-----	-----	-----	-----	-----	-----	-----	-----	-----	-----	-----	-----	-----	-----	-----	-----	-----	-----	-----	-----

**AADT and Expansion Factors provided by the City of Ottawa**

<b>AM Peak Hour Factor → 0.67</b>											<b>Highest Hourly Vehicle Volume between 0700h &amp; 1000h</b>												
<b>AM Peak Hr</b>	LT	ST	RT	UT	Total	LT	ST	RT	UT	Total	Str. Tot.	LT	ST	RT	UT	Total	LT	ST	RT	UT	Total	Str. Tot.	Gr. Tot.
0745-0845	0	83	134	0	217	227	57	0	0	284	501	22	0	120	0	142	0	0	0	0	0	142	643
<b>OFF Peak Hour Factor → N/A</b>											<b>Highest Hourly Vehicle Volume Between 1000h &amp; 1500h</b>												
<b>OFF Peak Hr</b>	LT	ST	RT	UT	Total	LT	ST	RT	UT	Total	Str. Tot.	LT	ST	RT	UT	Total	LT	ST	RT	UT	Total	Str. Tot.	Gr. Tot.
N/A	N/A	N/A	N/A	N/A	N/A	N/A	N/A	N/A	N/A	N/A	N/A	N/A	N/A	N/A	N/A	N/A	N/A	N/A	N/A	N/A	N/A	N/A	N/A
<b>PM Peak Hour Factor → 0.48</b>											<b>Highest Hourly Vehicle Volume Between 1500h &amp; 1900h</b>												
<b>PM Peak Hr</b>	LT	ST	RT	UT	Total	LT	ST	RT	UT	Total	Str. Tot.	LT	ST	RT	UT	Total	LT	ST	RT	UT	Total	Str. Tot.	Gr. Tot.
1500-1600	0	56	14	0	70	41	49	0	0	90	160	16	0	82	0	98	0	0	0	0	0	98	258

**Comments:**

OC Transpo buses and school buses comprise 92.73% of the heavy vehicle traffic. The southbound approach consists solely of a bicycle/pedestrian pathway.

**Notes:**

1. Includes all vehicle types except bicycles and electric scooters.
2. When expansion and AADT factors are applied, the results will differ slightly due to rounding.



# Turning Movement Count Summary, AM and PM Peak Hour Flow Diagrams All Vehicles Except Bicycles



## Earl of March Secondary School and The Parkway Kanata, ON

**All Vehicles**  
(Except Bicycles & Electric Scooters)

**Monday, April 22, 2024**  
0700-0930 & 1430-1730  
5.5 Hour Survey  
City of Ottawa Ward 4

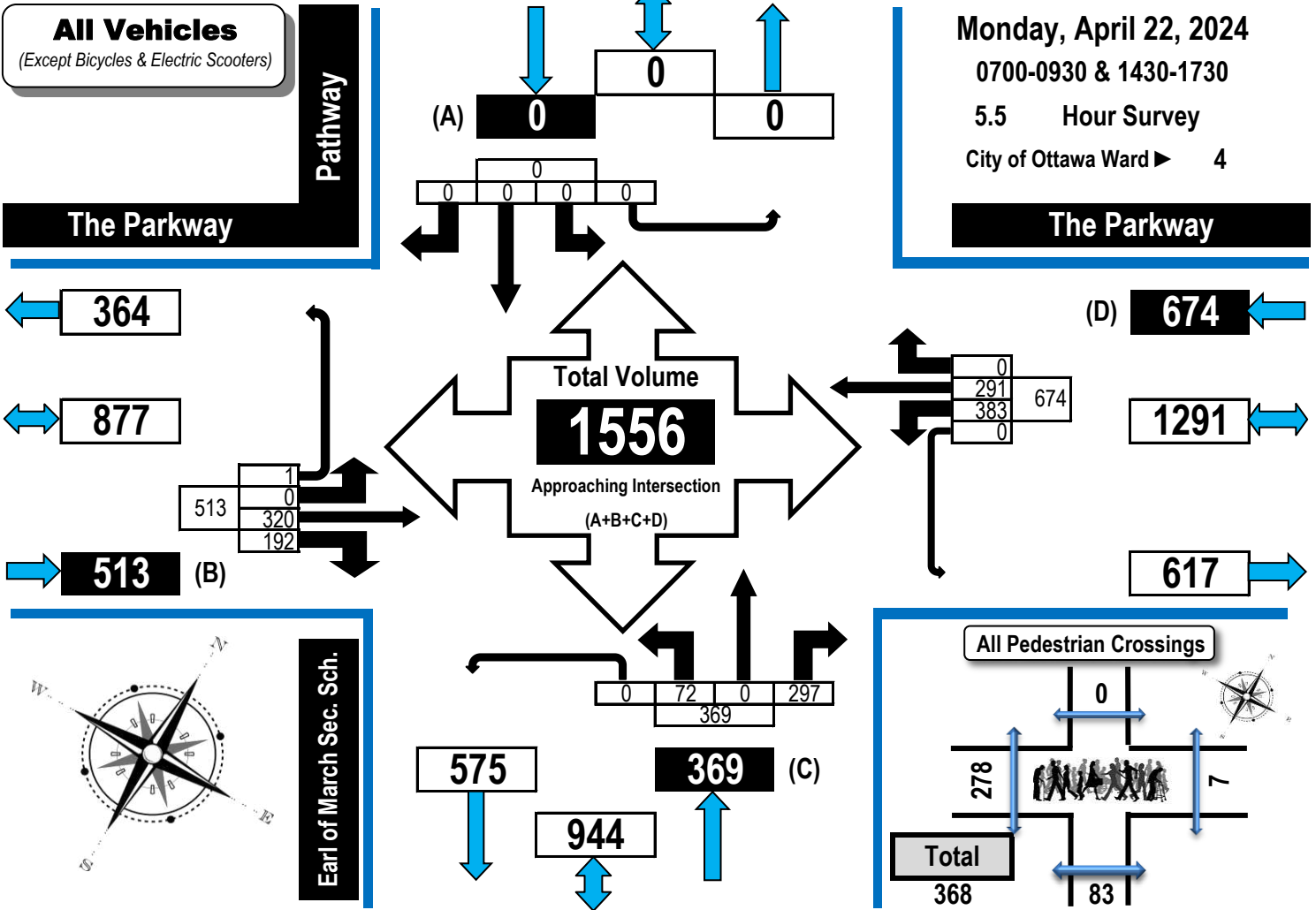

### AM Peak Hour Flow Diagram

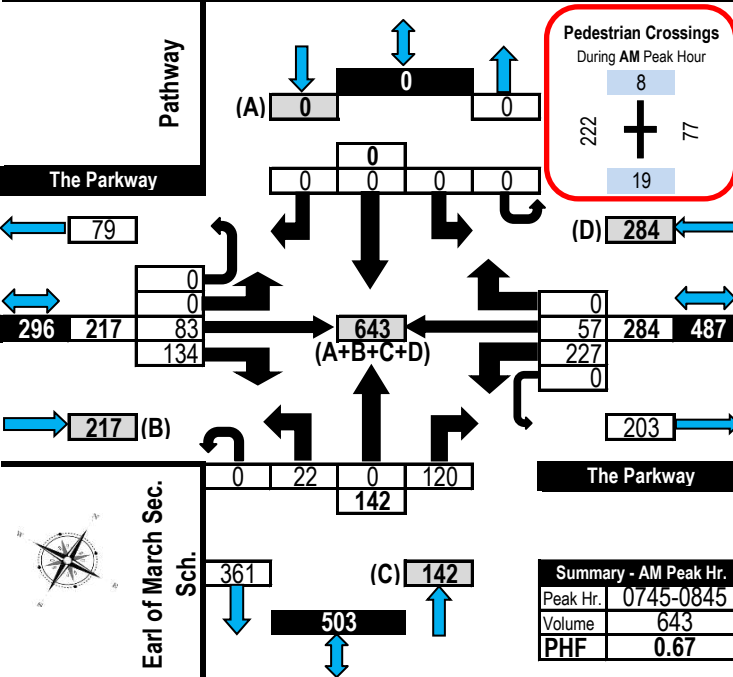

### PM Peak Hour Flow Diagram

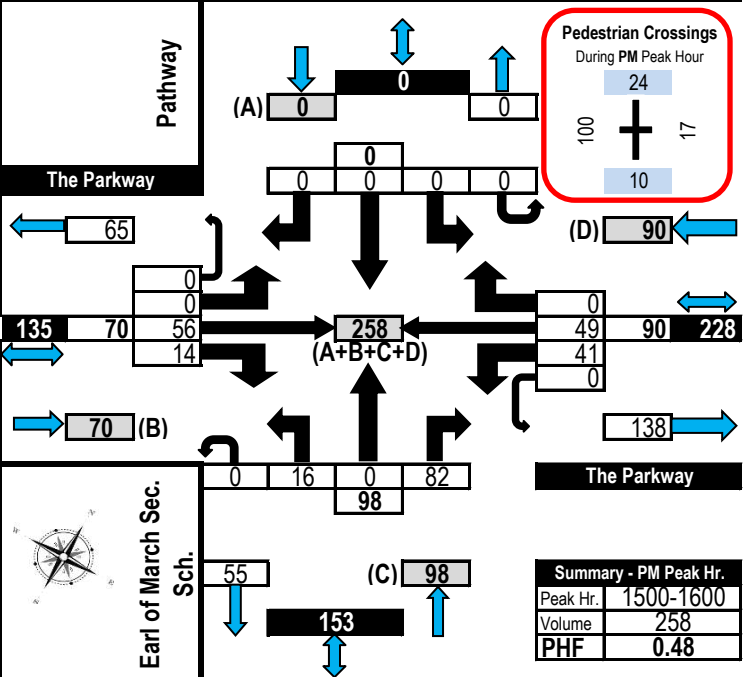



# Turning Movement Count Heavy Vehicle Summary (FHWA Class 4-13) Flow Diagram



## Earl of March Secondary School and The Parkway Kanata, ON

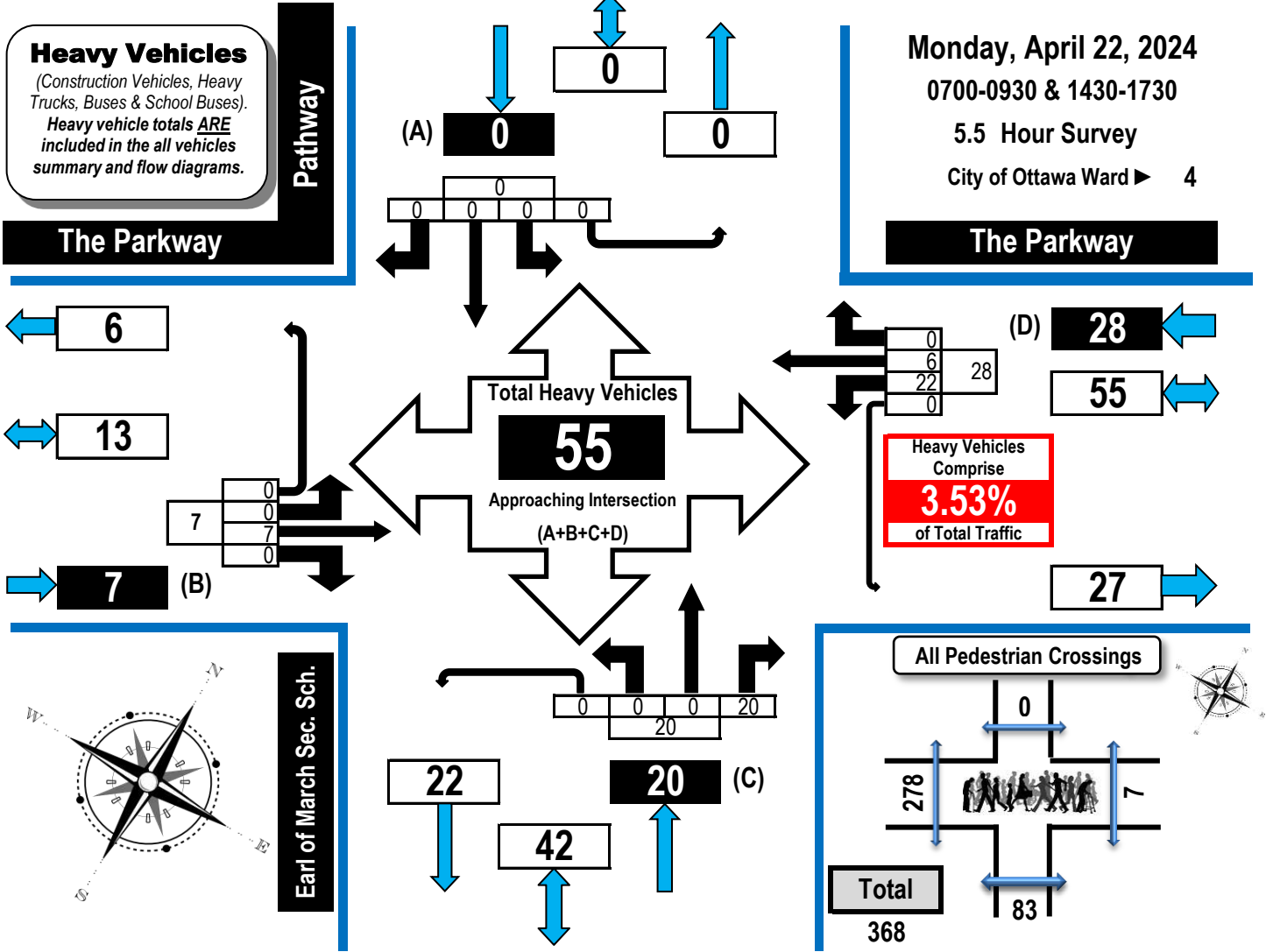

The Parkway Eastbound					The Parkway Westbound					Earl of March Sec. Sch. Northbound					Pathway Southbound					
LT	ST	RT	UT	EB Tot	LT	ST	RT	UT	WB Tot	LT	ST	RT	UT	NB Tot	LT	ST	RT	UT	SB Tot	GR Tot

Time Period	LT	ST	RT	UT	EB Tot	LT	ST	RT	UT	WB Tot	LT	ST	RT	UT	NB Tot	LT	ST	RT	UT	SB Tot	GR Tot
0700-0800	0	2	0	0	2	0	2	0	0	2	0	0	0	0	0	0	0	0	0	0	4
0800-0900	0	2	0	0	2	11	1	0	0	12	0	0	10	0	10	0	0	0	0	0	24
0900-0930	0	1	0	0	1	0	0	0	0	0	0	0	0	0	0	0	0	0	0	0	1
1430-1500	0	1	0	0	1	7	0	0	0	7	0	0	0	0	0	0	0	0	0	0	8
1500-1600	0	0	0	0	0	4	0	0	0	4	0	0	10	0	10	0	0	0	0	0	14
1600-1700	0	1	0	0	1	0	3	0	0	3	0	0	0	0	0	0	0	0	0	0	4
1700-1730	0	0	0	0	0	0	0	0	0	0	0	0	0	0	0	0	0	0	0	0	0
<b>Totals</b>	<b>0</b>	<b>7</b>	<b>0</b>	<b>0</b>	<b>7</b>	<b>22</b>	<b>6</b>	<b>0</b>	<b>0</b>	<b>28</b>	<b>0</b>	<b>0</b>	<b>20</b>	<b>0</b>	<b>20</b>	<b>0</b>	<b>0</b>	<b>0</b>	<b>0</b>	<b>0</b>	<b>55</b>



# Turning Movement Count All Buses Summary (FHWA Class 4 ONLY) Flow Diagram



## Earl of March Secondary School and The Parkway Kanata, ON

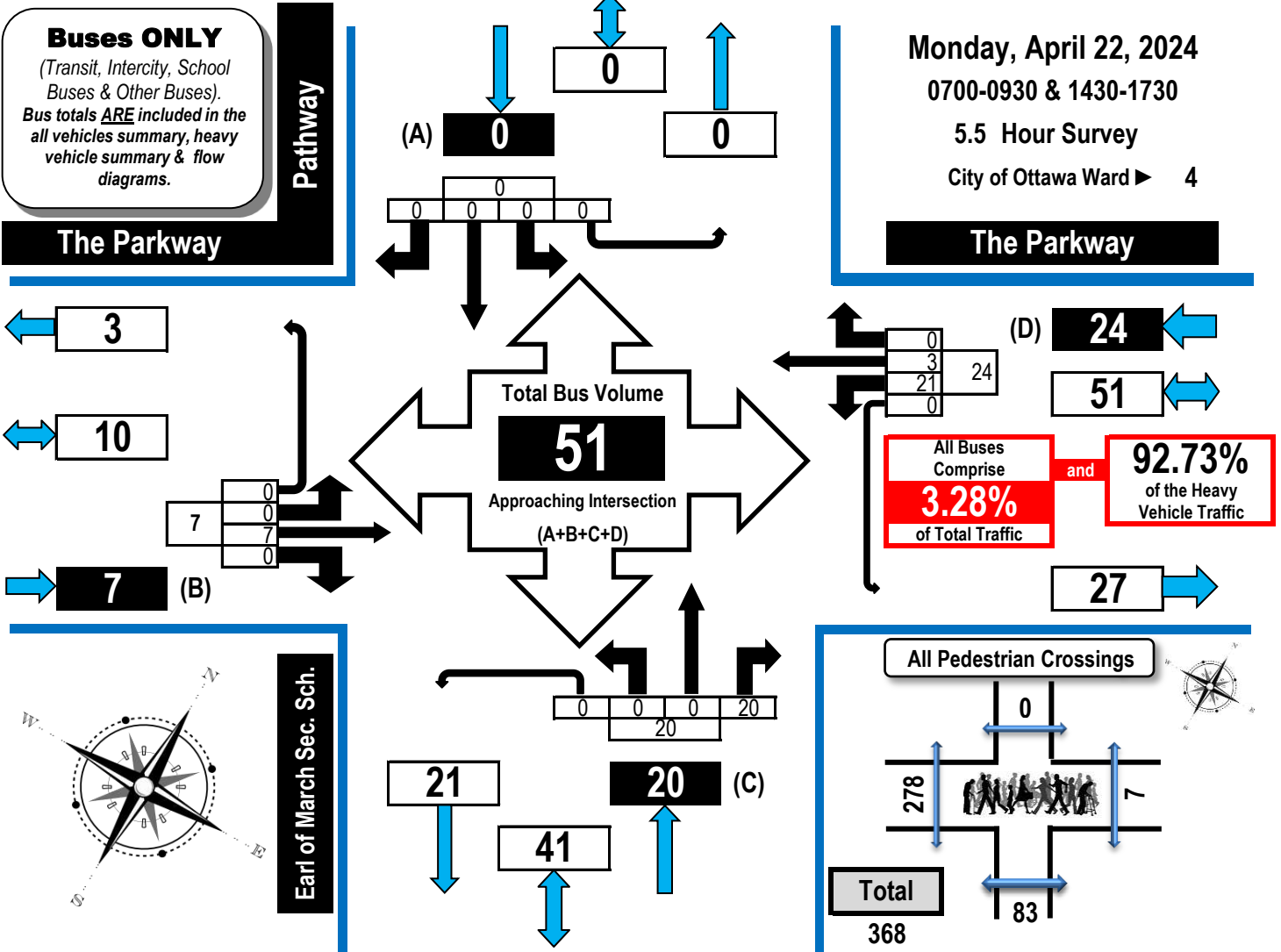

Time Period	The Parkway Eastbound					The Parkway Westbound					Earl of March Sec. Sch. Northbound					Pathway Southbound					GR Tot
	LT	ST	RT	UT	EB Tot	LT	ST	RT	UT	WB Tot	LT	ST	RT	UT	NB Tot	LT	ST	RT	UT	SB Tot	
0700-0800	0	2	0	0	2	0	1	0	0	1	0	0	0	0	0	0	0	0	0	0	3
0800-0900	0	2	0	0	2	10	0	0	0	10	0	0	10	0	10	0	0	0	0	0	22
0900-0930	0	1	0	0	1	0	0	0	0	0	0	0	0	0	0	0	0	0	0	0	1
1430-1500	0	1	0	0	1	7	0	0	0	7	0	0	0	0	0	0	0	0	0	0	8
1500-1600	0	0	0	0	0	4	0	0	0	4	0	0	10	0	10	0	0	0	0	0	14
1600-1700	0	1	0	0	1	0	2	0	0	2	0	0	0	0	0	0	0	0	0	0	3
1700-1730	0	0	0	0	0	0	0	0	0	0	0	0	0	0	0	0	0	0	0	0	0
<b>Totals</b>	<b>0</b>	<b>7</b>	<b>0</b>	<b>0</b>	<b>7</b>	<b>21</b>	<b>3</b>	<b>0</b>	<b>0</b>	<b>24</b>	<b>0</b>	<b>0</b>	<b>20</b>	<b>0</b>	<b>20</b>	<b>0</b>	<b>0</b>	<b>0</b>	<b>0</b>	<b>0</b>	<b>51</b>



# Turning Movement Count Bicycle Summary Flow Diagram



## Earl of March Secondary School and The Parkway Kanata, ON

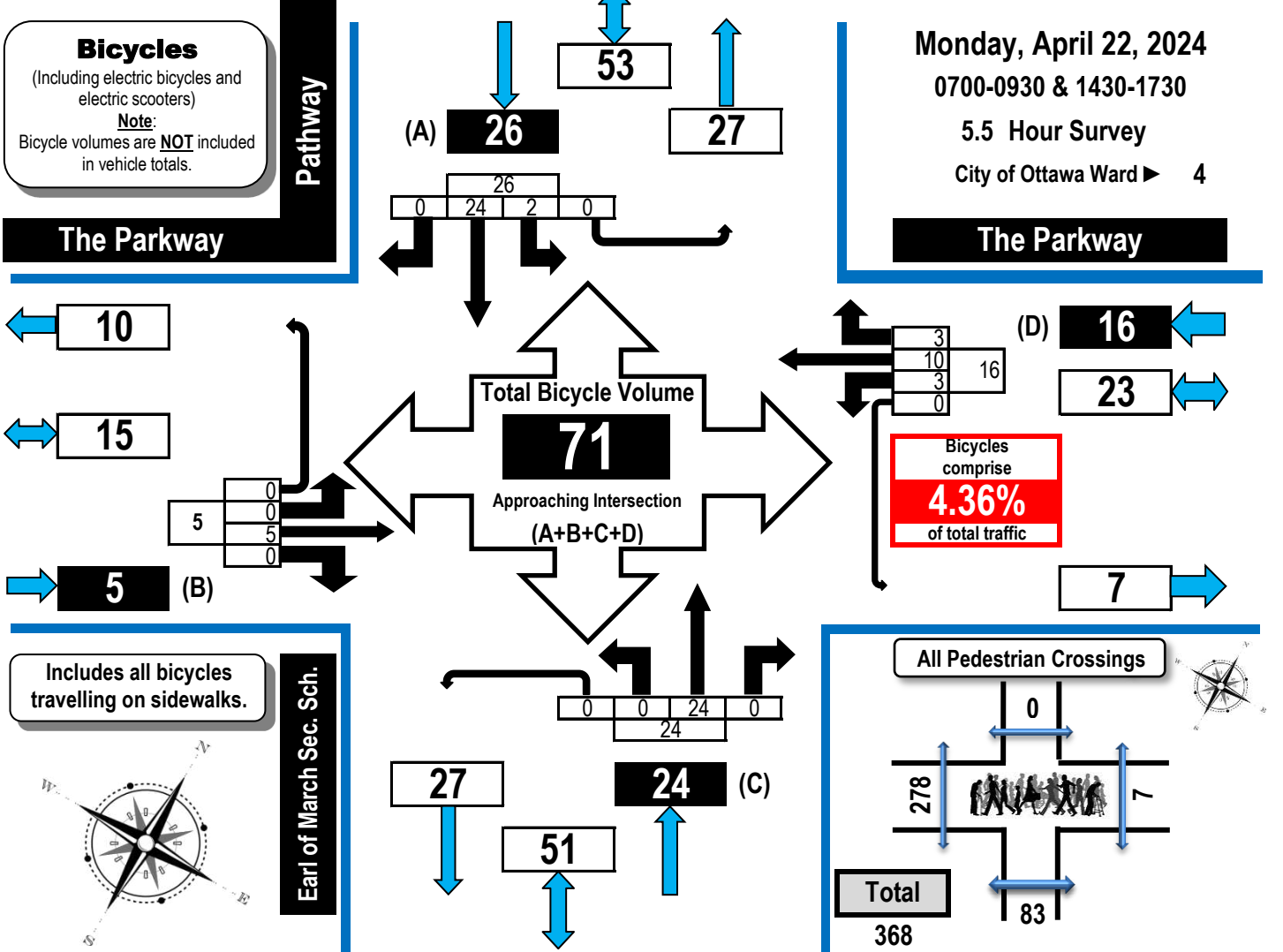

The Parkway Eastbound					The Parkway Westbound					Earl of March Sec. Sch. Northbound					Pathway Southbound					
LT	ST	RT	UT	EB Tot	LT	ST	RT	UT	WB Tot	LT	ST	RT	UT	NB Tot	LT	ST	RT	UT	SB Tot	GR Tot

Time Period	LT	ST	RT	UT	EB Tot	LT	ST	RT	UT	WB Tot	LT	ST	RT	UT	NB Tot	LT	ST	RT	UT	SB Tot	GR Tot
0700-0800	0	0	0	0	0	0	0	1	0	1	0	2	0	0	2	0	2	0	0	2	5
0800-0900	0	0	0	0	0	1	0	0	0	1	0	2	0	0	2	0	16	0	0	16	19
0900-0930	0	0	0	0	0	1	0	0	0	1	0	0	0	0	0	0	2	0	0	2	3
1430-1500	0	0	0	0	0	0	3	0	0	3	0	4	0	0	4	1	2	0	0	3	10
1500-1600	0	4	0	0	4	0	2	0	0	2	0	10	0	0	10	0	0	0	0	0	16
1600-1700	0	0	0	0	0	0	5	2	0	7	0	6	0	0	6	1	2	0	0	3	16
1700-1730	0	1	0	0	1	1	0	0	0	1	0	0	0	0	0	0	0	0	0	0	2
<b>Totals</b>	<b>0</b>	<b>5</b>	<b>0</b>	<b>0</b>	<b>5</b>	<b>3</b>	<b>10</b>	<b>3</b>	<b>0</b>	<b>16</b>	<b>0</b>	<b>24</b>	<b>0</b>	<b>0</b>	<b>24</b>	<b>2</b>	<b>24</b>	<b>0</b>	<b>0</b>	<b>26</b>	<b>71</b>



# Turning Movement Count Pedestrian Crossings Summary and Flow Diagram



**Earl of March Secondary School and The Parkway**

**Kanata, ON**

**Pedestrian Crossings**

**Monday, April 22, 2024**

0700-0930 & 1430-1730

5.5 Hour Survey

City of Ottawa Ward ► 4

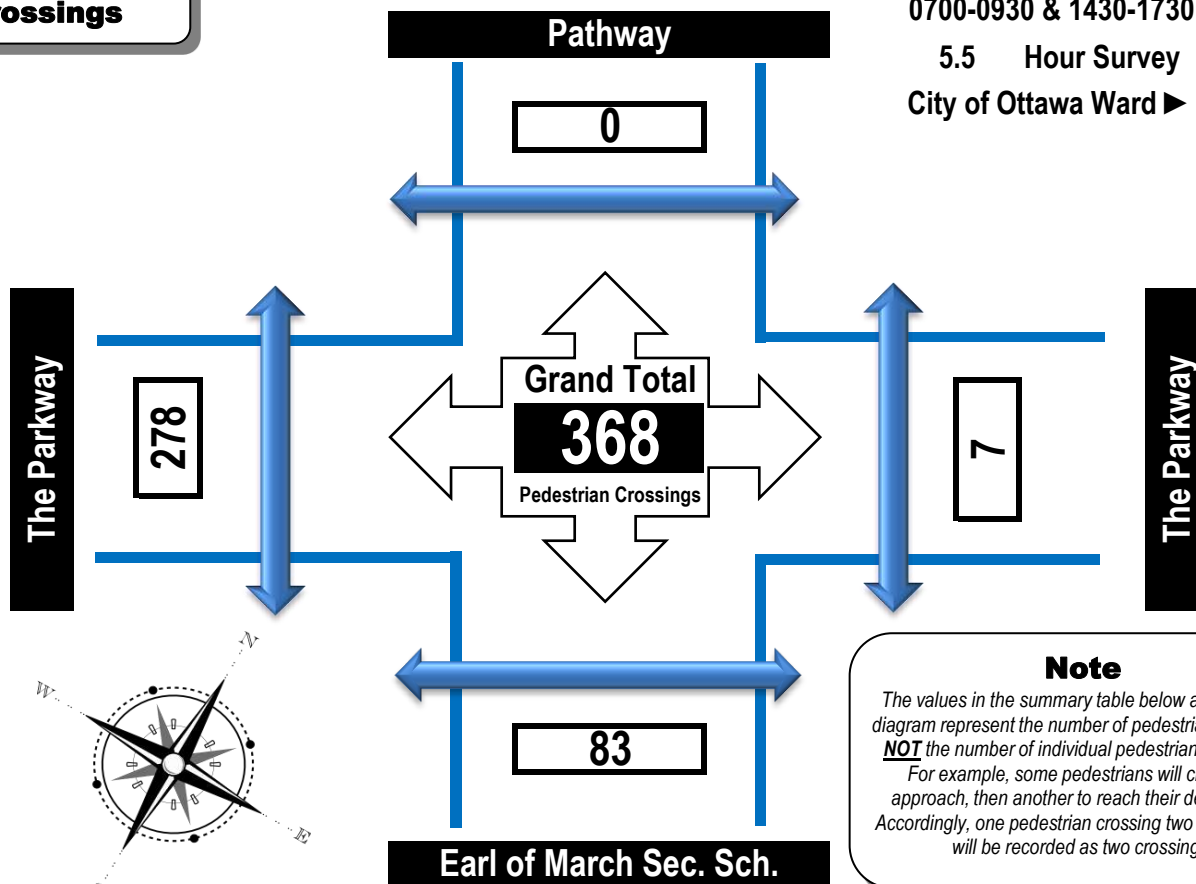

**Note**  
The values in the summary table below and the flow diagram represent the number of pedestrian crossings NOT the number of individual pedestrians crossing. For example, some pedestrians will cross one approach, then another to reach their destination. Accordingly, one pedestrian crossing two approaches will be recorded as two crossings.

Time Period	West Side Crossing	East Side Crossing	Street Total	South Side Crossing	North Side Crossing	Street Total	Grand Total
	The Parkway	The Parkway		Earl of March Sec. Sch.	Pathway		
0700-0800	14	4	18	13	0	13	31
0800-0900	93	0	93	6	0	6	99
0900-0930	8	0	8	4	0	4	12
1430-1500	64	0	64	12	0	12	76
1500-1600	58	0	58	32	0	32	90
1600-1700	28	3	31	8	0	8	39
1700-1730	13	0	13	8	0	8	21
<b>Totals</b>	<b>278</b>	<b>7</b>	<b>285</b>	<b>83</b>	<b>0</b>	<b>83</b>	<b>368</b>

**Comments:**

OC Transpo buses and school buses comprise 92.73% of the heavy vehicle traffic. The southbound approach consists solely of a bicycle/pedestrian pathway.

## Turning Movement Count - Study Results

### TERON RD @ PARKWAY (THE)/PENFIELD DR S

**Survey Date:** Wednesday, May 01, 2019

**WO No:** 38614

**Start Time:** 07:00

**Device:** Miovision

### AM Period Peak Hour Diagram

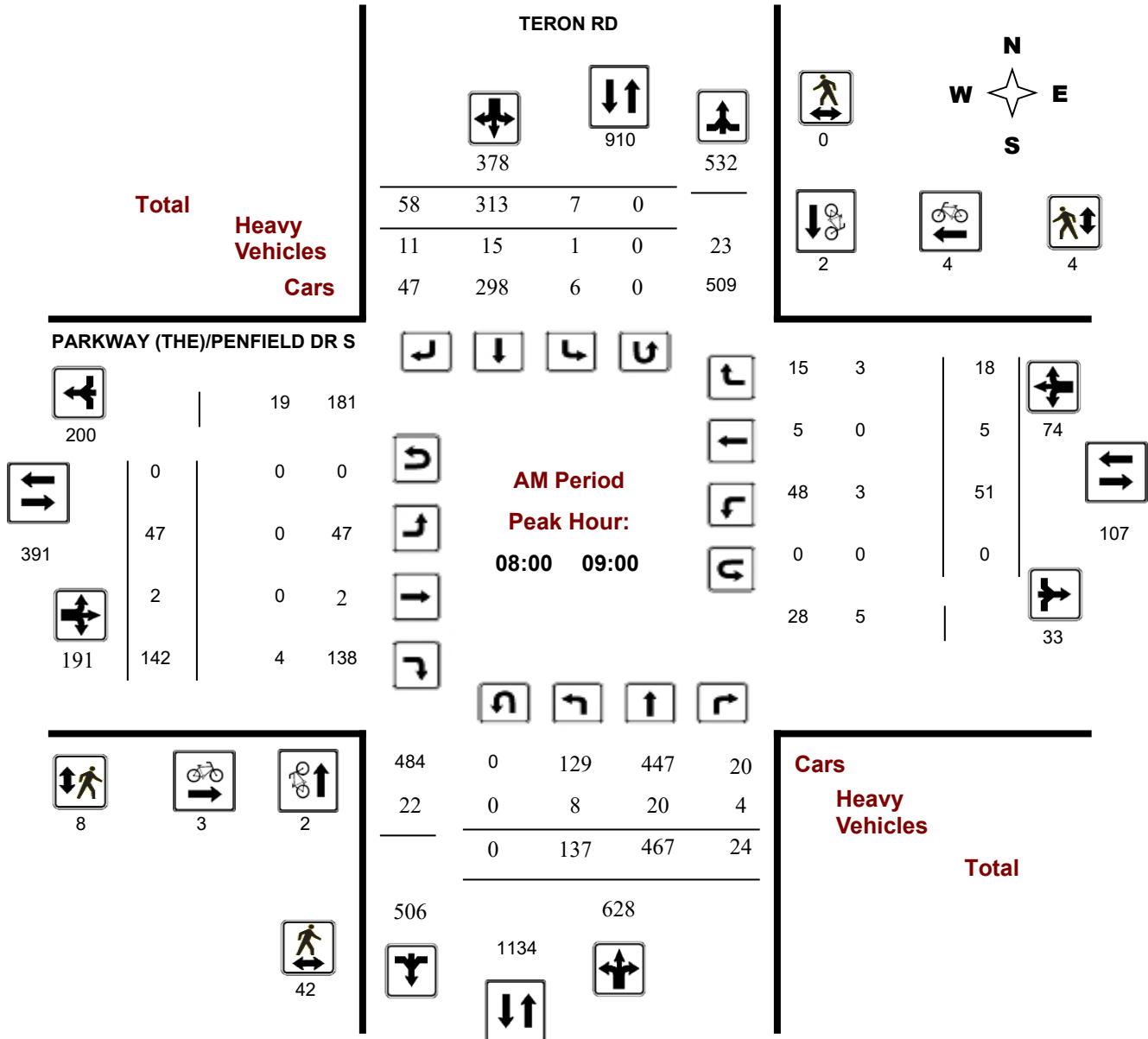

## Turning Movement Count - Study Results

### TERON RD @ PARKWAY (THE)/PENFIELD DR S

**Survey Date:** Wednesday, May 01, 2019

**WO No:**

38614

**Start Time:** 07:00

**Device:**

Miovision

### PM Period Peak Hour Diagram

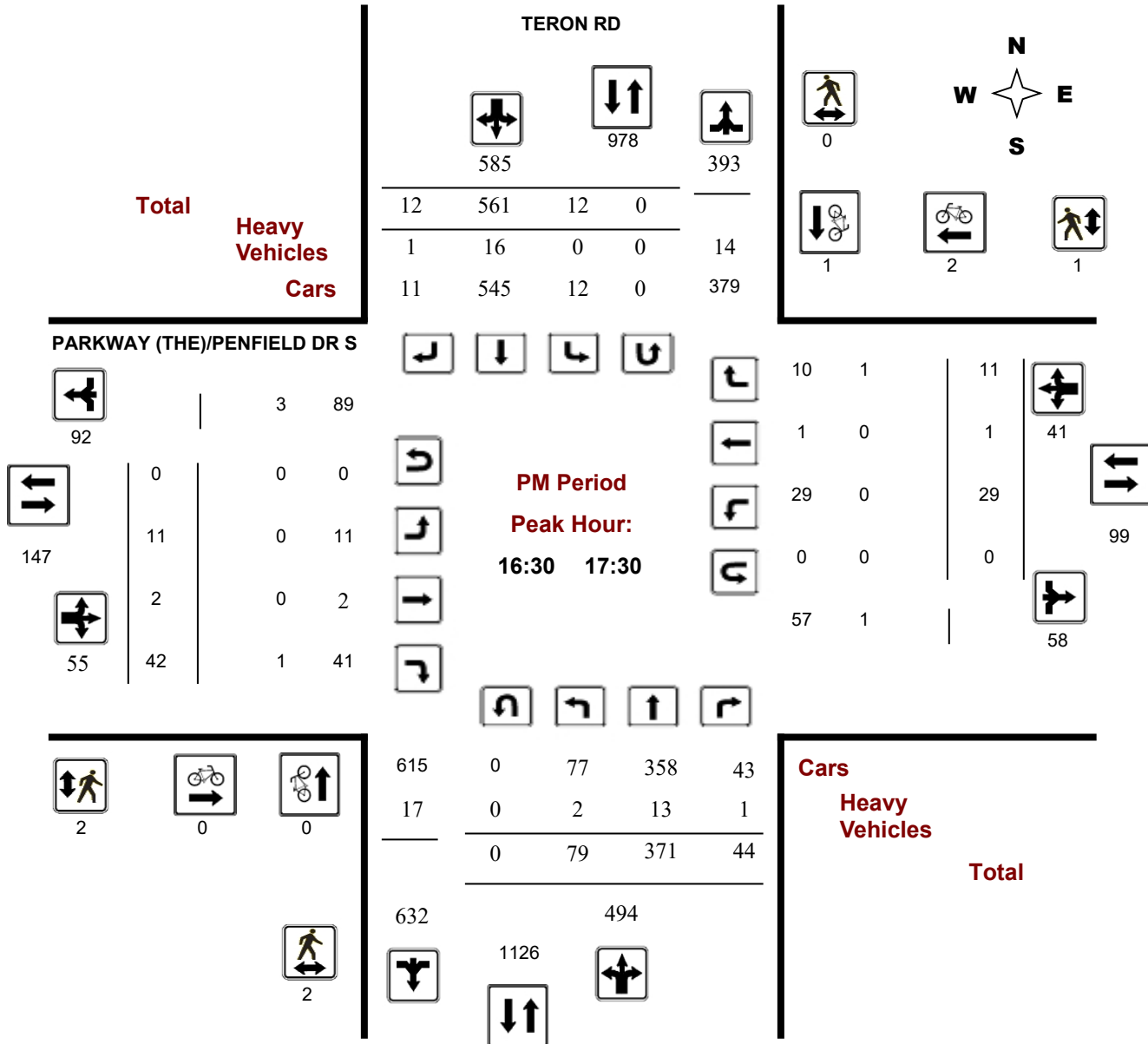



# Appendix D:

Historic Collision Data

**Total Area**

Classification of Accident	Rear End	Turning Movement	Sideswipe	Angle	Approaching	SMV other	SMV unattended vehicle	Other	Total
P.D. only	12	11	0	1	0	1	0	1	26
Non-fatal injury	2	9	0	1	0	2	0	0	14
Non-reportable	0	0	0	0	0	0	0	0	0
<b>Total</b>	<b>14</b>	<b>20</b>	<b>0</b>	<b>2</b>	<b>0</b>	<b>3</b>	<b>0</b>	<b>1</b>	<b>40</b>
	#2 or 35%	#1 or 50%	#6 or 0%	#4 or 5%	#6 or 0%	#3 or 8%	#6 or 0%	#5 or 3%	

65%  
35%  
0%  
100%

**THE PARKWAY/156 W OF TERON RD**

Years	Total # Collisions	24 Hr AADT Veh Volume	Days	Collisions/MEV
2018-2022	1	2,038	1825	<b>0.27</b>

Peds	Cyclists
0	0

Classification of Accident	Rear End	Turning Movement	Sideswipe	Angle	Approaching	SMV other	SMV unattended vehicle	Other	Total
P.D. only	0	1	0	0	0	0	0	0	1
Non-fatal injury	0	0	0	0	0	0	0	0	0
Non-reportable	0	0	0	0	0	0	0	0	0
<b>Total</b>	<b>0</b>	<b>1</b>	<b>0</b>	<b>0</b>	<b>0</b>	<b>0</b>	<b>0</b>	<b>0</b>	<b>1</b>
	0%	100%	0%	0%	0%	0%	0%	0%	

100%  
0%  
0%  
100%

**TERON RD/PARKWAY**

Years	Total # Collisions	24 Hr AADT Veh Volume	Days	Collisions/MEV
2018-2022	8	12,102	1825	<b>0.36</b>

Peds	Cyclists
1	0

Classification of Accident	Rear End	Turning Movement	Sideswipe	Angle	Approaching	SMV other	SMV unattended vehicle	Other	Total
P.D. only	4	1	0	1	0	0	0	0	6
Non-fatal injury	0	0	0	1	0	1	0	0	2
Non-reportable	0	0	0	0	0	0	0	0	0
<b>Total</b>	<b>4</b>	<b>1</b>	<b>0</b>	<b>2</b>	<b>0</b>	<b>1</b>	<b>0</b>	<b>0</b>	<b>8</b>
	50%	13%	0%	25%	0%	13%	0%	0%	

75%  
25%  
0%  
100%

**CAMPEAU DR/TERON RD/COLCHESTER SQ**

Years	Total # Collisions	24 Hr AADT Veh Volume	Days	Collisions/MEV
2018-2022	26	19,078	1825	<b>0.75</b>

Peds	Cyclists
0	0

Classification of Accident	Rear End	Turning Movement	Sideswipe	Angle	Approaching	SMV other	SMV unattended vehicle	Other	Total
P.D. only	7	8	0	0	0	1	0	1	17
Non-fatal injury	1	8	0	0	0	0	0	0	9
Non-reportable	0	0	0	0	0	0	0	0	0
<b>Total</b>	<b>8</b>	<b>16</b>	<b>0</b>	<b>0</b>	<b>0</b>	<b>1</b>	<b>0</b>	<b>1</b>	<b>26</b>
	31%	62%	0%	0%	0%	4%	0%	4%	

65%  
35%  
0%  
100%

**CAMPEAU DR/HAWKSTONE GT**

Years	Total # Collisions	24 Hr AADT Veh Volume	Days	Collisions/MEV
2018-2022	3	6,160	1825	<b>0.27</b>

Peds	Cyclists
1	1

Classification of Accident	Rear End	Turning Movement	Sideswipe	Angle	Approaching	SMV other	SMV unattended vehicle	Other	Total
P.D. only	1	0	0	0	0	0	0	0	1
Non-fatal injury	0	1	0	0	0	1	0	0	2
Non-reportable	0	0	0	0	0	0	0	0	0
<b>Total</b>	<b>1</b>	<b>1</b>	<b>0</b>	<b>0</b>	<b>0</b>	<b>1</b>	<b>0</b>	<b>0</b>	<b>3</b>
	33%	33%	0%	0%	0%	33%	0%	0%	

33%  
67%  
0%  
100%

**ROAD SEGMENTS**

**TERON RD, SALTER CRES to CAMPEAU DR**

Years	Total # Collisions	24 Hr AADT Veh Volume	Days	Collisions/MEV
2018-2022	1	n/a	1825	<b>n/a</b>

Peds	Cyclists
0	0

Classification of Accident	Rear End	Turning Movement	Sideswipe	Angle	Approaching	SMV other	SMV unattended vehicle	Other	Total
P.D. only	0	1	0	0	0	0	0	0	1
Non-fatal injury	0	0	0	0	0	0	0	0	0
Non-reportable	0	0	0	0	0	0	0	0	0
<b>Total</b>	<b>0</b>	<b>1</b>	<b>0</b>	<b>0</b>	<b>0</b>	<b>0</b>	<b>0</b>	<b>0</b>	<b>1</b>
	0%	100%	0%	0%	0%	0%	0%	0%	

100%  
0%  
0%  
100%

**CAMPEAU DR, HAWKSTONE GT to TERON RD/COLCHESTER SQ**

Years	Total # Collisions	24 Hr AADT Veh Volume	Days	Collisions/MEV
2018-2022	1	n/a	1825	<b>n/a</b>

Peds	Cyclists
0	0

Classification of Accident	Rear End	Turning Movement	Sideswipe	Angle	Approaching	SMV other	SMV unattended vehicle	Other	Total
P.D. only	0	0	0	0	0	0	0	0	0
Non-fatal injury	1	0	0	0	0	0	0	0	1
Non-reportable	0	0	0	0	0	0	0	0	0
<b>Total</b>	<b>1</b>	<b>0</b>	<b>0</b>	<b>0</b>	<b>0</b>	<b>0</b>	<b>0</b>	<b>0</b>	<b>1</b>
	100%	0%	0%	0%	0%	0%	0%	0%	

0%  
100%  
0%  
100%

# Appendix E:

Historic Traffic Growth

**Campeau/Teron**  
**8 hrs**

Year	Date	North Leg		South Leg		East Leg		West Leg		Total
		SB	NB	NB	SB	WB	EB	EB	WB	
2008	Wed Aug 6	2744	2369	394	568	3346	3662	2405	2269	17757
2010	Tues Aug 17	4052	3501	656	656	4432	4715	3437	3705	25154
2024	Tues Feb 13	3147	2991	683	593	3928	4121	2719	2772	20954

Year	Counts				% Change			
	NB	SB	NB+SB	INT	NB	SB	NB+SB	INT
2008	2369	2744	5113	17757				
2010	3501	4052	7553	25154	47.8%	47.7%	47.7%	41.7%
2024	2991	3147	6138	20954	-14.6%	-22.3%	-18.7%	-16.7%

Regression Estimate 2008 2887 3362 6249  
 Regression Estimate 2024 3065 3235 6300  
**Average Annual Change 0.37% -0.24% 0.05%**

Year	Counts				% Change			
	EB	WB	EB+WB	INT	EB	WB	EB+WB	INT
2008	2405	2269	4674	17757				
2010	3437	3705	7142	25154	42.9%	63.3%	52.8%	41.7%
2024	2719	2772	5491	20954	-20.9%	-25.2%	-23.1%	-16.7%

Regression Estimate 2008 2893 2944 5836  
 Regression Estimate 2024 2789 2868 5657  
**Average Annual Change -0.23% -0.16% -0.19%**

Year	Counts				% Change			
	EB	WB	EB+WB	INT	EB	WB	EB+WB	INT
2008	3662	3346	7008	17757				
2010	4715	4432	9147	25154	28.8%	32.5%	30.5%	41.7%
2024	4121	3928	8049	20954	-12.6%	-11.4%	-12.0%	-16.7%

Regression Estimate 2008 4151 3844 7995  
 Regression Estimate 2024 4191 3999 8190  
**Average Annual Change 0.06% 0.25% 0.15%**

Year	Counts				% Change			
	NB	SB	NB+SB	INT	NB	SB	NB+SB	INT
2008	394	568	962	17757				
2010	656	656	1312	25154	66.5%	15.5%	36.4%	41.7%
2024	683	593	1276	20954	4.1%	-9.6%	-2.7%	-16.7%

Regression Estimate 2008 505 610 1115  
 Regression Estimate 2024 699 599 1298  
**Average Annual Change 2.05% -0.11% 0.96%**

**Campeau/Teron  
AM Peak**

Year	Date	North Leg		South Leg		East Leg		West Leg		Total
		SB	NB	NB	SB	WB	EB	EB	WB	
2008	Wed Aug 6	447	319	43	45	334	714	430	176	2508
2010	Tues Aug 17	539	400	114	45	413	799	449	271	3030
2024	Tues Feb 13	499	536	159	94	593	761	481	341	3464

Year	Counts				% Change			
	NB	SB	NB+SB	INT	NB	SB	NB+SB	INT
2008	319	447	766	2508				
2010	400	539	939	3030	25.4%	20.6%	22.6%	20.8%
2024	536	499	1035	3464	34.0%	-7.4%	10.2%	14.3%

Regression Estimate 2008 345 489 834  
 Regression Estimate 2024 540 505 1045  
**Average Annual Change 2.83% 0.20% 1.41%**

Year	Counts				% Change			
	EB	WB	EB+WB	INT	EB	WB	EB+WB	INT
2008	430	176	606	2508				
2010	449	271	720	3030	4.4%	54.0%	18.8%	20.8%
2024	481	341	822	3464	7.1%	25.8%	14.2%	14.3%

Regression Estimate 2008 436 213 649  
 Regression Estimate 2024 482 346 828  
**Average Annual Change 0.62% 3.10% 1.54%**

Year	Counts				% Change			
	EB	WB	EB+WB	INT	EB	WB	EB+WB	INT
2008	714	334	1048	2508				
2010	799	413	1212	3030	11.9%	23.7%	15.6%	20.8%
2024	761	593	1354	3464	-4.8%	43.6%	11.7%	14.3%

Regression Estimate 2008 753 357 1110  
 Regression Estimate 2024 767 596 1363  
**Average Annual Change 0.11% 3.26% 1.29%**

Year	Counts				% Change			
	NB	SB	NB+SB	INT	NB	SB	NB+SB	INT
2008	43	45	88	2508				
2010	114	45	159	3030	165.1%	0.0%	80.7%	20.8%
2024	159	94	253	3464	39.5%	108.9%	59.1%	14.3%

Regression Estimate 2008 71 42 113  
 Regression Estimate 2024 163 94 257  
**Average Annual Change 5.35% 5.14% 5.27%**

**Campeau/Teron  
PM Peak**

Year	Date	North Leg		South Leg		East Leg		West Leg		Total
		SB	NB	NB	SB	WB	EB	EB	WB	
2008	Wed Aug 6	489	472	40	138	795	509	296	501	3240
2010	Tues Aug 17	682	645	86	142	940	630	475	766	4366
2024	Tues Feb 13	500	505	116	126	701	572	366	480	3366

Year	Counts				% Change			
	NB	SB	NB+SB	INT	NB	SB	NB+SB	INT
2008	472	489	961	3240				
2010	645	682	1327	4366	36.7%	39.5%	38.1%	34.8%
2024	505	500	1005	3366	-21.7%	-26.7%	-24.3%	-22.9%

Regression Estimate 2008 555 583 1138  
 Regression Estimate 2024 517 513 1030  
**Average Annual Change -0.44% -0.79% -0.62%**

Year	Counts				% Change			
	EB	WB	EB+WB	INT	EB	WB	EB+WB	INT
2008	296	501	797	3240				
2010	475	766	1241	4366	60.5%	52.9%	55.7%	34.8%
2024	366	480	846	3366	-22.9%	-37.3%	-31.8%	-22.9%

Regression Estimate 2008 380 632 1012  
 Regression Estimate 2024 378 499 877  
**Average Annual Change -0.03% -1.47% -0.89%**

Year	Counts				% Change			
	EB	WB	EB+WB	INT	EB	WB	EB+WB	INT
2008	509	795	1304	3240				
2010	630	940	1570	4366	23.8%	18.2%	20.4%	34.8%
2024	572	701	1273	3366	-9.2%	-25.4%	-18.9%	-22.9%

Regression Estimate 2008 565 872 1437  
 Regression Estimate 2024 580 712 1292  
**Average Annual Change 0.17% -1.26% -0.66%**

Year	Counts				% Change			
	NB	SB	NB+SB	INT	NB	SB	NB+SB	INT
2008	40	138	178	3240				
2010	86	142	228	4366	115.0%	2.9%	28.1%	34.8%
2024	116	126	242	3366	34.9%	-11.3%	6.1%	-22.9%

Regression Estimate 2008 58 141 199  
 Regression Estimate 2024 119 126 245  
**Average Annual Change 4.58% -0.67% 1.32%**

# Appendix F:

Truck Turning Templates

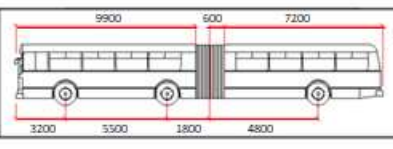

A-Bus Not to Scale  
Width : 2600 mm  
Track : 2600 mm  
Lock to Lock Time : 6.0  
Steering Angle : 40.2

Drawing Description	Site Circulation		
Client	Earl of March Secondary	Date	2024-11-13
Figure Number	1	Project Number	479060
Project Description			

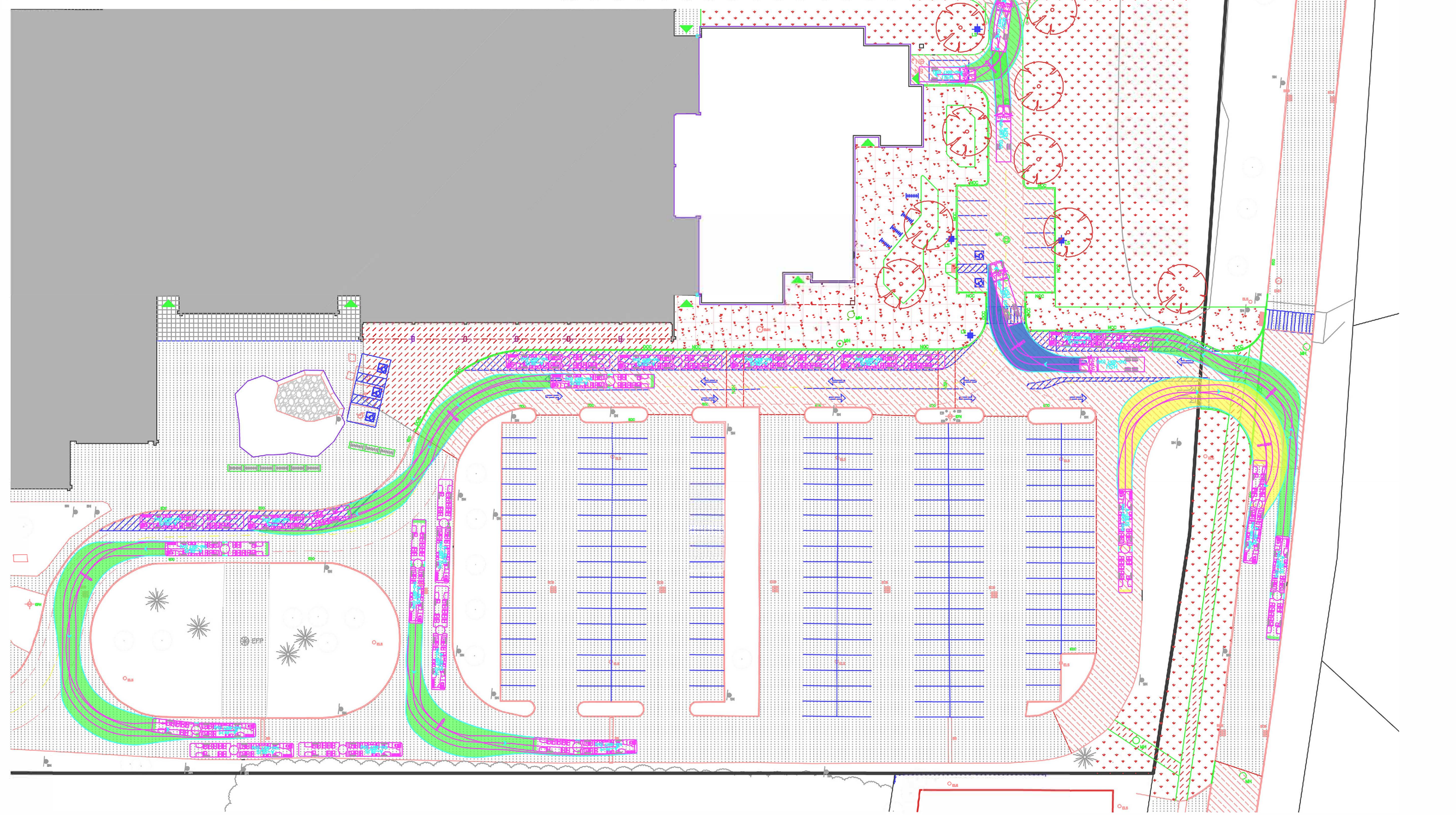



# Appendix G:

MMLOS: Road Segments

### Multi-Modal Level of Service - Segments Form

Consultant	Parsons
Scenario	Earl of March School
Comments	

Project	479060
Date	12-Jul-24

SEGMENTS	Street A	Campeau	Campeau	Parkway	Parkway	Parkway	Parkway	Section	Section	Section
		North	South	NW	SE Existing	Remainder	SE Future	7	8	9
Pedestrian	Sidewalk Width	≥ 2 m	1.8 m	≥ 2 m	< 1.5 m	no sidewalk	≥ 2 m		≥ 2 m	
	Boulevard Width	> 2 m	> 2 m	> 2 m	n/a	n/a	> 2 m		> 2 m	
	Avg Daily Curb Lane Traffic Volume	> 3000	> 3000	> 3000	> 3000	> 3000	> 3000		> 3000	
	Operating Speed	> 60 km/h	> 60 km/h	> 30 to 50 km/h	> 30 to 50 km/h	> 30 to 50 km/h	> 30 to 50 km/h		≤ 30 km/h	
	On-Street Parking	no	no	no	no	no	no		no	
	<b>Exposure to Traffic PLoS</b>	<b>D</b>	<b>E</b>	<b>B</b>	<b>F</b>	<b>F</b>	<b>B</b>	-	<b>A</b>	-
	Effective Sidewalk Width									
Pedestrian Volume										
<b>Crowding PLoS</b>	-	-	-	-	-	-	-	-	-	
<b>Level of Service</b>	-	-	-	-	-	-	-	-	-	
Bicycle	Type of Cycling Facility	Physically Separated	Physically Separated	Physically Separated	Mixed Traffic	Mixed Traffic	Mixed Traffic			
	Number of Travel Lanes				2-3 lanes total	2-3 lanes total	2-3 lanes total			
	Operating Speed				>40 to <50 km/h	>40 to <50 km/h	>40 to <50 km/h			
	<b># of Lanes &amp; Operating Speed LoS</b>	-	-	-	<b>D</b>	<b>D</b>	<b>D</b>	-	-	-
	Bike Lane (+ Parking Lane) Width									
	<b>Bike Lane Width LoS</b>	-	-	-	-	-	-	-	-	-
	Bike Lane Blockages									
	<b>Blockage LoS</b>	-	-	-	-	-	-	-	-	-
	Median Refuge Width (no median = < 1.8 m)				< 1.8 m refuge	< 1.8 m refuge	< 1.8 m refuge			
	No. of Lanes at Unsignalized Crossing				≤ 3 lanes	≤ 3 lanes	≤ 3 lanes			
Sidestreet Operating Speed				≤ 40 km/h	≤ 40 km/h	≤ 40 km/h				
<b>Unsignalized Crossing - Lowest LoS</b>	<b>A</b>	<b>A</b>	<b>A</b>	<b>A</b>	<b>A</b>	<b>A</b>	-	-	-	
<b>Level of Service</b>	<b>A</b>	<b>A</b>	<b>A</b>	<b>D</b>	<b>D</b>	<b>D</b>	-	-	-	
Transit	Facility Type	Mixed Traffic	Mixed Traffic	Mixed Traffic	Mixed Traffic	Mixed Traffic	Mixed Traffic			
	Friction or Ratio Transit:Posted Speed	Vt/Vp ≥ 0.8	Vt/Vp ≥ 0.8	Vt/Vp ≥ 0.8	Vt/Vp ≥ 0.8	Vt/Vp ≥ 0.8	Vt/Vp ≥ 0.8			
	<b>Level of Service</b>	<b>D</b>	<b>D</b>	<b>D</b>	<b>D</b>	<b>D</b>	<b>D</b>	-	-	-
Truck	Truck Lane Width	≤ 3.3 m	≤ 3.3 m	≤ 3.5 m	≤ 3.5 m	≤ 3.5 m	≤ 3.5 m			
	Travel Lanes per Direction	1	1	1	1	1	1			
	<b>Level of Service</b>	<b>D</b>	<b>D</b>	<b>C</b>	<b>C</b>	<b>C</b>	<b>C</b>	-	-	-

# Appendix H:

TDM Checklist

**TDM-Supportive Development Design and Infrastructure Checklist:**  
*Non-Residential Developments (office, institutional, retail or industrial)*

<b>Legend</b>	
<b>REQUIRED</b>	The Official Plan or Zoning By-law provides related guidance that must be followed
<b>BASIC</b>	The measure is generally feasible and effective, and in most cases would benefit the development and its users
<b>BETTER</b>	The measure could maximize support for users of sustainable modes, and optimize development performance

TDM-supportive design & infrastructure measures: <i>Non-residential developments</i>		Check if completed & add descriptions, explanations or plan/drawing references
<b>1. WALKING &amp; CYCLING: ROUTES</b>		
<b>1.1 Building location &amp; access points</b>		
BASIC	1.1.1 Locate building close to the street, and do not locate parking areas between the street and building entrances	<input checked="" type="checkbox"/> direct pathways from road to entrance proposed.
BASIC	1.1.2 Locate building entrances in order to minimize walking distances to sidewalks and transit stops/stations	<input checked="" type="checkbox"/> transit operates internal to site, adjacent to front door.
BASIC	1.1.3 Locate building doors and windows to ensure visibility of pedestrians from the building, for their security and comfort	<input checked="" type="checkbox"/> modern design with windows.
<b>1.2 Facilities for walking &amp; cycling</b>		
REQUIRED	1.2.1 Provide convenient, direct access to stations or major stops along rapid transit routes within 600 metres; minimize walking distances from buildings to rapid transit; provide pedestrian-friendly, weather-protected (where possible) environment between rapid transit accesses and building entrances; ensure quality linkages from sidewalks through building entrances to integrated stops/stations <i>(see Official Plan policy 4.3.3)</i>	<input checked="" type="checkbox"/> transit operates internal to site, adjacent to front door.
REQUIRED	1.2.2 Provide safe, direct and attractive pedestrian access from public sidewalks to building entrances through such measures as: reducing distances between public sidewalks and major building entrances; providing walkways from public streets to major building entrances; within a site, providing walkways along the front of adjoining buildings, between adjacent buildings, and connecting areas where people may congregate, such as courtyards and transit stops; and providing weather protection through canopies, colonnades, and other design elements wherever possible <i>(see Official Plan policy 4.3.12)</i>	<input checked="" type="checkbox"/> direct pathways from road to entrance proposed.

TDM-supportive design & infrastructure measures: <i>Non-residential developments</i>		Check if completed & add descriptions, explanations or plan/drawing references
REQUIRED	1.2.3 Provide sidewalks of smooth, well-drained walking surfaces of contrasting materials or treatments to differentiate pedestrian areas from vehicle areas, and provide marked pedestrian crosswalks at intersection sidewalks ( <i>see Official Plan policy 4.3.10</i> )	<input checked="" type="checkbox"/> sidewalks to be designed to code.
REQUIRED	1.2.4 Make sidewalks and open space areas easily accessible through features such as gradual grade transition, depressed curbs at street corners and convenient access to extra-wide parking spaces and ramps ( <i>see Official Plan policy 4.3.10</i> )	<input checked="" type="checkbox"/> Provided.
REQUIRED	1.2.5 Include adequately spaced inter-block/street cycling and pedestrian connections to facilitate travel by active transportation. Provide links to the existing or planned network of public sidewalks, multi-use pathways and on-road cycle routes. Where public sidewalks and multi-use pathways intersect with roads, consider providing traffic control devices to give priority to cyclists and pedestrians ( <i>see Official Plan policy 4.3.11</i> )	<input checked="" type="checkbox"/> Wide sidewalk connecting to MUP on The Parkway.
BASIC	1.2.6 Provide safe, direct and attractive walking routes from building entrances to nearby transit stops	<input checked="" type="checkbox"/> transit operates internal to site, adjacent to front door.
BASIC	1.2.7 Ensure that walking routes to transit stops are secure, visible, lighted, shaded and wind-protected wherever possible	<input checked="" type="checkbox"/> transit operates internal to site, adjacent to front door.
BASIC	1.2.8 Design roads used for access or circulation by cyclists using a target operating speed of no more than 30 km/h, or provide a separated cycling facility	<input checked="" type="checkbox"/> internal roads designed for low operating speeds.
<b>1.3 Amenities for walking &amp; cycling</b>		
BASIC	1.3.1 Provide lighting, landscaping and benches along walking and cycling routes between building entrances and streets, sidewalks and trails	<input checked="" type="checkbox"/> lighting provided.
BASIC	1.3.2 Provide wayfinding signage for site access (where required, e.g. when multiple buildings or entrances exist) and egress (where warranted, such as when directions to reach transit stops/stations, trails or other common destinations are not obvious)	<input type="checkbox"/>

TDM-supportive design & infrastructure measures: <i>Non-residential developments</i>		Check if completed & add descriptions, explanations or plan/drawing references
<b>2. WALKING &amp; CYCLING: END-OF-TRIP FACILITIES</b>		
<b>2.1 Bicycle parking</b>		
REQUIRED	2.1.1 Provide bicycle parking in highly visible and lighted areas, sheltered from the weather wherever possible (see <i>Official Plan policy 4.3.6</i> )	<input checked="" type="checkbox"/> Bicycle parking provided.
REQUIRED	2.1.2 Provide the number of bicycle parking spaces specified for various land uses in different parts of Ottawa; provide convenient access to main entrances or well-used areas (see <i>Zoning By-law Section 111</i> )	<input checked="" type="checkbox"/> Bicycle parking exceeds minimums.
REQUIRED	2.1.3 Ensure that bicycle parking spaces and access aisles meet minimum dimensions; that no more than 50% of spaces are vertical spaces; and that parking racks are securely anchored (see <i>Zoning By-law Section 111</i> )	<input checked="" type="checkbox"/> Bicycle parking to meet requirements.
BASIC	2.1.4 Provide bicycle parking spaces equivalent to the expected number of commuter cyclists (assuming the cycling mode share target is met), plus the expected peak number of customer/visitor cyclists	<input checked="" type="checkbox"/> Bicycle parking exceeds minimums.
BETTER	2.1.5 Provide bicycle parking spaces equivalent to the expected number of commuter and customer/visitor cyclists, plus an additional buffer (e.g. 25 percent extra) to encourage other cyclists and ensure adequate capacity in peak cycling season	<input checked="" type="checkbox"/> Bicycle parking exceeds minimums.
<b>2.2 Secure bicycle parking</b>		
REQUIRED	2.2.1 Where more than 50 bicycle parking spaces are provided for a single office building, locate at least 25% of spaces within a building/structure, a secure area (e.g. supervised parking lot or enclosure) or bicycle lockers (see <i>Zoning By-law Section 111</i> )	<input checked="" type="checkbox"/> Bicycle parking to meet requirements.
BETTER	2.2.2 Provide secure bicycle parking spaces equivalent to the expected number of commuter cyclists (assuming the cycling mode share target is met)	<input checked="" type="checkbox"/> Bicycle parking exceeds minimums.
<b>2.3 Shower &amp; change facilities</b>		
BASIC	2.3.1 Provide shower and change facilities for the use of active commuters	<input checked="" type="checkbox"/> Shower facilities exist on site.
BETTER	2.3.2 In addition to shower and change facilities, provide dedicated lockers, grooming stations, drying racks and laundry facilities for the use of active commuters	<input checked="" type="checkbox"/> Change facilities and lockers exist on site.
<b>2.4 Bicycle repair station</b>		
BETTER	2.4.1 Provide a permanent bike repair station, with commonly used tools and an air pump, adjacent to the main bicycle parking area (or secure bicycle parking area, if provided)	<input type="checkbox"/>

TDM-supportive design & infrastructure measures: <i>Non-residential developments</i>		Check if completed & add descriptions, explanations or plan/drawing references
<b>3. TRANSIT</b>		
<b>3.1 Customer amenities</b>		
BASIC	3.1.1 Provide shelters, lighting and benches at any on-site transit stops	<input checked="" type="checkbox"/> lighting provided. Operating hours generally within daytime.
BASIC	3.1.2 Where the site abuts an off-site transit stop and insufficient space exists for a transit shelter in the public right-of-way, protect land for a shelter and/or install a shelter	<input type="checkbox"/> Not applicable.
BETTER	3.1.3 Provide a secure and comfortable interior waiting area by integrating any on-site transit stops into the building	<input checked="" type="checkbox"/> Buses arrive prior to bell (no waiting anticipated)
<b>4. RIDESHARING</b>		
<b>4.1 Pick-up &amp; drop-off facilities</b>		
BASIC	4.1.1 Provide a designated area for carpool drivers (plus taxis and ride-hailing services) to drop off or pick up passengers without using fire lanes or other no-stopping zones	<input type="checkbox"/>
<b>4.2 Carpool parking</b>		
BASIC	4.2.1 Provide signed parking spaces for carpools in a priority location close to a major building entrance, sufficient in number to accommodate the mode share target for carpools	<input type="checkbox"/>
BETTER	4.2.2 At large developments, provide spaces for carpools in a separate, access-controlled parking area to simplify enforcement	<input type="checkbox"/>
<b>5. CARSHARING &amp; BIKESHARING</b>		
<b>5.1 Carshare parking spaces</b>		
BETTER	5.1.1 Provide carshare parking spaces in permitted non-residential zones, occupying either required or provided parking spaces ( <i>see Zoning By-law Section 94</i> )	<input type="checkbox"/>
<b>5.2 Bikeshare station location</b>		
BETTER	5.2.1 Provide a designated bikeshare station area near a major building entrance, preferably lighted and sheltered with a direct walkway connection	<input type="checkbox"/>

TDM-supportive design & infrastructure measures: <i>Non-residential developments</i>		Check if completed & add descriptions, explanations or plan/drawing references
<b>6. PARKING</b>		
<b>6.1 Number of parking spaces</b>		
<b>REQUIRED</b>	6.1.1 Do not provide more parking than permitted by zoning, nor less than required by zoning, unless a variance is being applied for	<input checked="" type="checkbox"/> Parking meets requirements.
<b>BASIC</b>	6.1.2 Provide parking for long-term and short-term users that is consistent with mode share targets, considering the potential for visitors to use off-site public parking	<input type="checkbox"/>
<b>BASIC</b>	6.1.3 Where a site features more than one use, provide shared parking and reduce the cumulative number of parking spaces accordingly ( <i>see Zoning By-law Section 104</i> )	<input type="checkbox"/>
<b>BETTER</b>	6.1.4 Reduce the minimum number of parking spaces required by zoning by one space for each 13 square metres of gross floor area provided as shower rooms, change rooms, locker rooms and other facilities for cyclists in conjunction with bicycle parking ( <i>see Zoning By-law Section 111</i> )	<input type="checkbox"/>
<b>6.2 Separate long-term &amp; short-term parking areas</b>		
<b>BETTER</b>	6.2.1 Separate short-term and long-term parking areas using signage or physical barriers, to permit access controls and simplify enforcement (i.e. to discourage employees from parking in visitor spaces, and vice versa)	<input type="checkbox"/>
<b>7. OTHER</b>		
<b>7.1 On-site amenities to minimize off-site trips</b>		
<b>BETTER</b>	7.1.1 Provide on-site amenities to minimize mid-day or mid-commute errands	<input type="checkbox"/>



**TDM Measures Checklist:**

*Non-Residential Developments (office, institutional, retail or industrial)*

<b>Legend</b>	
<b>BASIC</b>	The measure is generally feasible and effective, and in most cases would benefit the development and its users
<b>BETTER</b>	The measure could maximize support for users of sustainable modes, and optimize development performance
<b>*</b>	The measure is one of the most dependably effective tools to encourage the use of sustainable modes

<b>TDM measures: <i>Non-residential developments</i></b>		<b>Check if proposed &amp; add descriptions</b>
<b>1. TDM PROGRAM MANAGEMENT</b>		
<b>1.1 Program coordinator</b>		
<b>BASIC</b>	<b>*</b> 1.1.1 Designate an internal coordinator, or contract with an external coordinator	<input checked="" type="checkbox"/>
<b>1.2 Travel surveys</b>		
<b>BETTER</b>	1.2.1 Conduct periodic surveys to identify travel-related behaviours, attitudes, challenges and solutions, and to track progress	<input type="checkbox"/>
<b>2. WALKING AND CYCLING</b>		
<b>2.1 Information on walking/cycling routes &amp; destinations</b>		
<b>BASIC</b>	2.1.1 Display local area maps with walking/cycling access routes and key destinations at major entrances	<input checked="" type="checkbox"/>
<b>2.2 Bicycle skills training</b>		
<i>Commuter travel</i>		
<b>BETTER</b>	<b>*</b> 2.2.1 Offer on-site cycling courses for commuters, or subsidize off-site courses	<input type="checkbox"/>
<b>2.3 Valet bike parking</b>		
<i>Visitor travel</i>		
<b>BETTER</b>	2.3.1 Offer secure valet bike parking during public events when demand exceeds fixed supply (e.g. for festivals, concerts, games)	<input type="checkbox"/> Not applicable

TDM measures: <i>Non-residential developments</i>		Check if proposed & add descriptions
<b>3. TRANSIT</b>		
<b>3.1 Transit information</b>		
BASIC	3.1.1 Display relevant transit schedules and route maps at entrances	<input checked="" type="checkbox"/>
BASIC	3.1.2 Provide online links to OC Transpo and STO information	<input checked="" type="checkbox"/> <a href="http://www.ottawaschoolbus.ca">www.ottawaschoolbus.ca</a> <a href="http://www.octranspo.com/en/alerts/">www.octranspo.com/en/alerts/</a> .
BETTER	3.1.3 Provide real-time arrival information display at entrances	<input type="checkbox"/> Not applicable.
<b>3.2 Transit fare incentives</b>		
<i>Commuter travel</i>		
BETTER	3.2.1 Offer preloaded PRESTO cards to encourage commuters to use transit	<input checked="" type="checkbox"/> Students receive Presto Cards for the school year.
BETTER *	3.2.2 Subsidize or reimburse monthly transit pass purchases by employees	<input type="checkbox"/>
<i>Visitor travel</i>		
BETTER	3.2.3 Arrange inclusion of same-day transit fare in price of tickets (e.g. for festivals, concerts, games)	<input type="checkbox"/> Not applicable.
<b>3.3 Enhanced public transit service</b>		
<i>Commuter travel</i>		
BETTER	3.3.1 Contract with OC Transpo to provide enhanced transit services (e.g. for shift changes, weekends)	<input type="checkbox"/>
<i>Visitor travel</i>		
BETTER	3.3.2 Contract with OC Transpo to provide enhanced transit services (e.g. for festivals, concerts, games)	<input type="checkbox"/> Not applicable.
<b>3.4 Private transit service</b>		
<i>Commuter travel</i>		
BETTER	3.4.1 Provide shuttle service when OC Transpo cannot offer sufficient quality or capacity to serve demand (e.g. for shift changes, weekends)	<input type="checkbox"/> Not applicable.
<i>Visitor travel</i>		
BETTER	3.4.2 Provide shuttle service when OC Transpo cannot offer sufficient quality or capacity to serve demand (e.g. for festivals, concerts, games)	<input type="checkbox"/> Not applicable.

TDM measures: <i>Non-residential developments</i>		Check if proposed & add descriptions
<b>4. RIDESHARING</b>		
<b>4.1 Ridematching service</b>		
<i>Commuter travel</i>		
BASIC	4.1.1 Provide a dedicated ridematching portal at OttawaRideMatch.com	<input type="checkbox"/> Service suspended since COVID-19
<b>4.2 Carpool parking price incentives</b>		
<i>Commuter travel</i>		
BETTER	4.2.1 Provide discounts on parking costs for registered carpools	<input type="checkbox"/>
<b>4.3 Vanpool service</b>		
<i>Commuter travel</i>		
BETTER	4.3.1 Provide a vanpooling service for long-distance commuters	<input type="checkbox"/>
<b>5. CARSHARING &amp; BIKESHARING</b>		
<b>5.1 Bikeshare stations &amp; memberships</b>		
BETTER	5.1.1 Contract with provider to install on-site bikeshare station for use by commuters and visitors	<input type="checkbox"/> Safety issues, not possible
<i>Commuter travel</i>		
BETTER	5.1.2 Provide employees with bikeshare memberships for local business travel	<input type="checkbox"/>
<b>5.2 Carshare vehicles &amp; memberships</b>		
<i>Commuter travel</i>		
BETTER	5.2.1 Contract with provider to install on-site carshare vehicles and promote their use by tenants	<input type="checkbox"/>
BETTER	5.2.2 Provide employees with carshare memberships for local business travel	<input type="checkbox"/>
<b>6. PARKING</b>		
<b>6.1 Priced parking</b>		
<i>Commuter travel</i>		
BASIC	6.1.1 Charge for long-term parking (daily, weekly, monthly)	<input type="checkbox"/> Safety issues, not possible
BASIC	6.1.2 Unbundle parking cost from lease rates at multi-tenant sites	<input type="checkbox"/>
<i>Visitor travel</i>		
BETTER	6.1.3 Charge for short-term parking (hourly)	<input type="checkbox"/>

TDM measures: <i>Non-residential developments</i>		Check if proposed & add descriptions
<b>7. TDM MARKETING &amp; COMMUNICATIONS</b>		
<b>7.1 Multimodal travel information</b>		
<i>Commuter travel</i>		
BASIC	* 7.1.1 Provide a multimodal travel option information package to new/relocating employees and students	<input checked="" type="checkbox"/> OCDSB HR
<i>Visitor travel</i>		
BETTER	* 7.1.2 Include multimodal travel option information in invitations or advertising that attract visitors or customers (e.g. for festivals, concerts, games)	<input type="checkbox"/>
<b>7.2 Personalized trip planning</b>		
<i>Commuter travel</i>		
BETTER	* 7.2.1 Offer personalized trip planning to new/relocating employees	<input type="checkbox"/>
<b>7.3 Promotions</b>		
<i>Commuter travel</i>		
BETTER	7.3.1 Deliver promotions and incentives to maintain awareness, build understanding, and encourage trial of sustainable modes	<input type="checkbox"/>
<b>8. OTHER INCENTIVES &amp; AMENITIES</b>		
<b>8.1 Emergency ride home</b>		
<i>Commuter travel</i>		
BETTER	* 8.1.1 Provide emergency ride home service to non-driving commuters	<input type="checkbox"/>
<b>8.2 Alternative work arrangements</b>		
<i>Commuter travel</i>		
BASIC	* 8.2.1 Encourage flexible work hours	<input type="checkbox"/> Not applicable.
BETTER	8.2.2 Encourage compressed workweeks	<input type="checkbox"/> Not applicable.
BETTER	* 8.2.3 Encourage telework	<input type="checkbox"/> Not applicable.
<b>8.3 Local business travel options</b>		
<i>Commuter travel</i>		
BASIC	* 8.3.1 Provide local business travel options that minimize the need for employees to bring a personal car to work	<input type="checkbox"/>
<b>8.4 Commuter incentives</b>		
<i>Commuter travel</i>		
BETTER	8.4.1 Offer employees a taxable, mode-neutral commuting allowance	<input type="checkbox"/>
<b>8.5 On-site amenities</b>		
<i>Commuter travel</i>		
BETTER	8.5.1 Provide on-site amenities/services to minimize mid-day or mid-commute errands	<input type="checkbox"/>

