

West Capital Airpark City of Ottawa, Ontario

Phase 1B-2 Residential –
SBS[®] Sanitary Collection Design Brief

Prepared for City of Ottawa

February 2024

**West Capital Airpark
City of Ottawa, Ontario**

**SBS® Sanitary Collection System
Phase 1B-2 - Residential**

Design Brief

Prepared for City of Ottawa

February 2024

Brief Prepared By:

Clearford Water System Inc.
Suite 300, 1545 Carling Ave.
Ottawa, Ontario
K1Z 8P9

Tel – (613) 599-6474
Fax – (613) 599-7478

TABLE OF CONTENTS

1.0	INTRODUCTION.....	2
2.0	SITE DESCRIPTION.....	2
2.1	General Site Information.....	2
2.2	Existing and Proposed Development.....	2
3.0	SANITARY COLLECTION SYSTEM.....	3
3.1	Existing Residential Phase 1A Servicing.....	3
3.2	Proposed Residential Phase 2A Servicing.....	3
3.2.1	Design Parameters.....	4
3.2.2	Interceptor Tanks.....	5
3.2.3	Sanitary SBS® Mains, Laterals and SAPs.....	6
3.3	Capacity Review of Existing SBS® System.....	6
3.3.1	Existing Gravity Sewer Mains.....	6
3.3.2	Existing Inverted Siphon.....	7
3.4	Installation of SBS® System.....	7
3.4.1	Interceptor Tanks.....	7
3.4.2	Sanitary SBS® Mains, Laterals and SAPs.....	7
3.4.3	CCTV Camera Inspection and Pressure Testing.....	8
3.5	Operation and Maintenance.....	8
3.5.1	Interceptor Tanks.....	8
3.5.2	Sanitary SBS® Mains, Laterals and SAPs.....	8
4.0	SUMMARY.....	8

APPENDICES

- Appendix A: Plan View and Schematic of Proposed SBS® Collection System
- Appendix B: Ontario MECC – Environmental Compliance Approval
- Appendix C: Ontario MOE – NETE Certificate
- Appendix D: Interceptor Tank Details
- Appendix E: SBS® Sanitary Sewer Design Sheet
- Appendix F: System Access Points and Collection System Details

1.0 INTRODUCTION

Clearford Water Systems Inc. has been retained to complete the detailed design of a Small Bore Sewer (SBS®) sanitary collection system for residential Phase 1B-2 of the West Capital Airpark (WCA) development in Ottawa, Ontario.

The sanitary SBS® system is a small diameter gravity sewer (SDGS) system with variable gradient (refer to Section 5.15.4 of the MOE Design Guidelines for Sewage Works, 2008). Residential Phase 1 sanitary SBS® servicing has been approved under Environmental Compliance Approval No. 0961-A9UHS8 (Appendix B). Under this approval, the downstream sanitary sewer mains of Phase 1 would allow new connections of future phases to be served within the approved treatment system capacity.

This Design Brief has been prepared for the sanitary servicing of the proposed Phase 1B-2 development. Wastewater generation based on the build-out of previously approved residential Phases has been used for the review of the hydraulic capacity of the proposed sanitary system. Descriptions are provided for the design parameters, installation, operation and maintenance of the proposed Phase 1B-2 sanitary collection system.

2.0 SITE DESCRIPTION

2.1 General Site Information

The WCA is a private residential development and business park located on a 400-acre property in the west end of the City of Ottawa. This site is bounded by agricultural land to the northwest, Diamondview Road on the southwest, Thomas Argue Road on the northeast, and aggregate pits to the southeast. One small creek crosses the site from south to north. The residential development site lies south of the existing airport facilities; the business park development is to the northeast of the existing facilities and adjacent to Carp Road.

2.2 Existing and Proposed Development

The development of WCA Phase 1 includes 212 residential lots and one City Park staged into three (3) construction phases: existing Phases 1A and 1B-1 and proposed Phase 1B-2. The sanitary sewer servicing for Phase 1A has been installed for 77 single family houses and the City Park. Phase 1B-1 has been registered for servicing 28 single family houses, while the proposed Phase 1B-2 is planned for 77 single family houses and 30 townhouse units.

The existing Phase 2A was approved under the Transfer of Review Program (TORP) delegated to the City in 2020. The sanitary sewer servicing for Phase 2A has been installed for 82 single family houses and 48 townhouse units.

The total of existing Phase 1A, 1B-1, 2A, and proposed phase 1B-2 residential development will include 342 residential lots and 2 equivalent residential units contributed from the City Park of Phase 1A.

Although the original Phase 1 sanitary SBS® collection system has been approved under Environmental Compliance Approval No. 0961-A9UHS8 (Appendix B) for Phase 1A and 1B only, the downstream sewer mains are sized with a total capacity to accommodate wastewater

generation up to 329 residential lots and some common sites up to 15 equivalent residential units (ERUs) which equal to the total of existing Phase 1A, 1B-1, 2A, and proposed phase 1B-2 residential development. A summary of the residential and ERU counts is provided in Table 3.2

3.0 SANITARY COLLECTION SYSTEM

Refer to Appendix A for a plan view and schematic of the sanitary sewer collection system for the existing and proposed residential development in Phase 1A, Phase 1B (1B-1 and 1B-2) and Phase 2A.

3.1 Existing Residential Phase 1A, 1B-1 and 2A Servicing

The existing sanitary SBS® collection system for WCA residential development is classified as a small diameter variable gradient sewer system (refer to “An Introduction to Communal Sewage Systems,” MOE, ISBN 0-7778-6933-0). The system is comprised of at-source clarification with the liquid effluent transported by gravity through small diameter service laterals and sanitary mains (75-200 mm diameter) to an effluent pumping station to lift effluent to the wastewater treatment facility.

Interceptor tanks of 4,000 L working volume are located on each residential lot that will be owned, operated and maintained by a condominium corporation. The interceptor tanks provide at-source separation of sewage waste solids, fats, oils and greases (FOGs), and allow for storage and digestion of the accumulated sludge. Additionally, the clarification process reduces peak flows through attenuation in the system and provides pre-treatment of the domestic wastewater through reduction of the biological oxygen demand (BOD) and total suspended solids (TSS).

An inverted siphon has been constructed to transport effluent from the west to east side of Carp Creek on Wingover Pvt. The siphon consists of two parallel 100 mm diameter pipelines that eliminate the need for an additional pumping station within the residential development.

The small diameter sanitary laterals and mains constructed from high-density polyethylene (HDPE) provide a watertight collection system using pipe fusion/welding technologies and the elimination of maintenance hole requirements. System cleanouts, called system access points (SAPs), are installed to allow for monitoring, maintenance and periodic flushing of the system. All components of the existing SBS® collection system in WCA residential development have been tested after installation to ensure a watertight system.

3.2 Proposed Residential Phase 1B-2 Servicing

The proposed residential Phase 1B-2 adjoins Phase 1B-1 located east of Carp Creek and will be comprised of a mixture of 107 single family homes and townhomes. Sanitary servicing for the proposed development is designed based on the previously approved ECA for implementing a sanitary SBS® gravity collection system. Each residential home will have an individual interceptor tank located at front yard of the property. Raw sewage from homes will be connected to the inlet pipe of interceptor tanks, where settleable solids in the sewage will be captured in the tank after a minimum of 48 hours retention time. The liquid tank effluent will drain through service laterals to the SBS® mains in the road rights-of-way.

Two (2) sanitary collection areas have been proposed for the new development. In Phase 1B-2, twenty-eight (28) single-family houses will connect to the existing 100mm SBS® main from Phase 1B-1 on Chandelle Pvt. Service laterals for these twenty-eight (28) residential homes will be established through installed tee connections which are currently plugged and will be extended into the properties. Due to a crossing conflict with a proposed storm sewer, the existing 100mm SBS® main of Phase 1B-1 will be cut off at the location prior to the road crossing (approximate chainage 9+996). Subsequently, it will be diverted to a new SBS main on the proposed Chandelle Pvt. extension. The existing 100mm SBS® main beyond this point will be capped and abandoned.

The remaining seventy-nine (79) residential units will be serviced by new SBS® mains on proposed Chandelle Pvt. extension and Street Three, with a minimum burial depth of 2.2m below the edge of road elevations. The proposed Phase 1B-2 sanitary flows will connect to an existing sanitary cap located at approximate Chainage 401+053 in Phase 1B-1. Following the connection cap, these sanitary flows will be directed through the existing 150mm SBS® main adjacent to the Stormwater Management East Pond. The existing 150mm SBS® main then feeds to the downstream 200mm SBS® main of Phase 1A on Wingover Pvt. which terminates at the existing sanitary sewer manhole at the intersection of Wingover Pvt. and Thomas Argue Rd.

At the termination point of the collection system, the sanitary sewer from existing and proposed residential phases will be entering by gravity the existing effluent pumping station and lifted to the above-grade wastewater treatment plant for further treatment. The pumping station and WWTP design for WCA residential development is provided by others under separate cover. The treated final effluent is discharged via pipe outfall to an onsite dry ditch approximately 30 m from the treatment facility.

3.2.1 Design Parameters

The assumptions and design parameters used for sizing and hydraulic design of the proposed Phase 1B-2 SBS® collection system are presented in Table 3.1.

Table 3.1: Summary of Residential Phase 1B-2 SBS® Design Parameters

Parameter	Design Value	Reference
Residential ADF Generation ^a	290 L/cap/day	MOE typical 225-450 L/cap/day
Housing Density	3.4 capita/single home	City of Ottawa Standards
	2.7 capita/townhome	City of Ottawa Standards
Equivalent Residential Unit (ERU) ^b	986 L/single home/day	Single family home
Peaking Factor ^c	2.0	MOE NETE Certificate
Inflow/Infiltration ^c	0 L/cap/day	MOE NETE Certificate
Sanitary SBS® Lateral Diameter	75 mm	MOE Sewage Works 2008
Sanitary SBS® Main Diameter ^c	75 mm – 150 mm	MOE NETE Certificate
Manning's Roughness for HDPE DR17	0.013	MOE Sewage Works 2008
Minimum Cleansing Velocity	0.15m/s	MOE NETE Certificate
Minimum Slope	0.15%	MOE NETE Certificate
Cleanout Max. Spacing	90 m	MOE NETE Certificate
Minimum Burial Depth for Mains	2.20 m	Frost protection purpose
Minimum Burial Depth for Interceptors	0.30 m	Manufacturer's guide
Interceptor Min. Hydraulic Retention Time	2 days	OBC Section 8.2.2.3.

Notes:

- ^a Refer to approved “Phase 1 Residential – SBS® Sanitary Collection Design Brief”, April 2015.
^b Based on single home density of 3.4 capita/home
^c Refer to Appendix C: *Ontario MOE – NETE Certificate* has an approved peaking factor of 2 and I/I=0, which was used in this sewer design

The sewage generation rates for existing and proposed residential phases are summarized by development type in Table 3.2.

Table 3.2: Wastewater Generation in Each Phase

Phases	Property	ERU Connections	Population (capita)	Design Average Flow, Q _A (L/d)	Peak Flow (L/s)
Existing Phase 1A	Single homes	77	261.8	75,922	1.76
	City Park	2	-	2,000	0.05
Existing Phase 2A	Single homes	82	278.8	80,852	1.87
	Townhomes	48	129.6	37,584	0.87
Existing & Proposed Phase 1B	Existing single homes	28	95.2	27,608	0.64
	Proposed single homes	77	261.8	75,922	1.76
	Proposed Townhomes	30	81.0	23,490	0.54
Existing & Proposed Total		344	1,108.2	323,378	7.49

3.2.2 Interceptor Tanks

The interceptor tanks are designed to perform at-source solids separation, clarification, solids retention and primary treatment. The sizing of interceptor tanks has been determined based on the occupancy, flow generation rates and the required minimum of 48 hours hydraulic retention time specified in Table 3.1. The calculated hydraulic retention time of interceptor tanks in residential Phase 1B-2 are provided in Table 3.3.

Table 3.3: Hydraulic Retention Time of Interceptor Tanks

Property	Tank Working Capacity (L)	Occupancy Density (capita/home)	Design Average Flow Q _A (L/day)	HRT (days)
Single home	4,000	3.4	986	4.1
Town home	4,000	2.7	783	5.1

The volume of sludge production is expected to vary significantly from home to home based on the actual occupancy density and habits of individual residents. Collection and storage of solids occurs year-round, with the contents of the tanks to be pumped out and disposed off-site by a licensed hauler.

The estimated raw sewage and SBS® effluent wastewater characteristics are presented in Table 3.4.

Table 3.4: Interceptor Tank Wastewater Characteristics

Parameter	Raw Sewage Average Concentration ^a	SBS® Effluent Average Concentration ^a
Biochemical Oxygen Demand (BOD ₅)	170 mg/L	120 mg/L
Total Suspended Solids (TSS)	200 mg/L	80 mg/L
Total Kjeldahl Nitrogen (TKN)	62.9 mg/L	62.9 mg/L
Total Ammonia Nitrogen (TAN)	53.5 mg/L	53.5 mg/L
Total Phosphorus (TP)	10 mg/L	10 mg/L

^a Refer to information supplied by Golder Associates, "Report on Wastewater Treatment System Carp Airport", January 2015.

3.2.3 Sanitary SBS® Mains, Laterals and SAPs

The sanitary SBS® laterals from the interceptor tank outlet to the sanitary SBS® main will be 75 mm diameter sewer, while the sanitary SBS® mains in residential Phase 1B-2 will range from 75 mm to 150 mm diameter. Each segment of pipe was analyzed using the Manning's Equation and a peaking factor of two, to account for the attenuation of peak flow that occurs in the interceptor tanks. Each sanitary main was designed to carry the peak flow with a half-full pipe condition as an additional safety factor.

Refer to Appendix E for the complete hydraulic design calculations for the collection system. The Design Sheet has been updated to include the as-built information from existing phases and the design flows for the proposed development.

System access points (SAPs) are designed to allow for routine maintenance, monitoring and periodic flushing. SAPs will be installed at the start of each pipe run and throughout the sewer main network with a maximum separation distance of 90 metres.

Venting of the SBS® pipe network is critical to maintaining flow in the system and eliminating the potential for "air lock" conditions. Venting is passively achieved through headspace in the laterals, interceptor tanks, and plumbing vent stacks for each residential connection; additionally, air breather caps will be installed on SAPs for increased venting of the system.

3.3 Capacity Review of Existing SBS® System

The hydraulic conveyance capacity and peak flow velocity in the existing SBS® mains were assessed based on the theoretical design criteria presented in Table 3.1 and 3.2 and the as-built data of existing sanitary sewer mains.

3.3.1 Existing Gravity Sewer Mains

The capacities of existing gravity SBS® mains, specifically installed downstream of the proposed development on Chandelle Pvt. and Wingover Pvt. and along the Stormwater Management East Pond, were analysed for conveyance of the total peak design flow with a maximum design ratio (Q_p/Q_f) of 50% under available hydraulic slopes resulting from sanitary sewer as-builts.

Design calculations included in Appendix E show that the existing SBS® mains have sufficient capacity to accommodate the total peak design flow from all existing and proposed phases. Additionally, the cleansing velocity in all pipe segments is maintained at or above the minimum 0.15 m/s. It is noted that these calculations are based on the design assumptions which may be different than actual flows discharging into the system.

3.3.2 Existing Inverted Siphon

The inverted siphon is upstream of the proposed development, so the hydraulic capacity of inverted siphon will not be impacted by the proposed development.

3.4 Installation of SBS® System

3.4.1 Interceptor Tanks

Refer to Appendix D for interceptor tank details. The proposed interceptor tanks are injection-molded polypropylene tanks. These structurally reinforced plastic tanks are lightweight and durable for easy assembly and handling. Tanks are designed to withstand typical stresses associated with installation by heavy equipment and burial. The tank is constructed with a main body in two (2) pieces with inlet and outlet access hatches and adjustable plastic risers. Alternative tank material with equal or better properties is acceptable upon Clearford's review.

Installation requires excavation, including any rock removal, preparation of the bedding material, placement of the tank, backfilling and compaction, connection of inlet and outlet plumbing, and installation of access hatches.

Rubber gasket seals are set into the inlet and outlet pipe positions providing watertight pipe connections. Access hatches are provided at inlet location to allow for inspection, maintenance, and sludge pumping. Modular plastic riser ring components are stacked such that the risers extend to grade level for access.

Installation requirements for the interceptor tanks are summarized below.

1. Interceptor tank locations selected based on the following considerations:
 - a) Minimize length of pipe for the sewer lateral from building to interceptor tank.
 - b) Allow equipment access for excavation and interceptor tank placement.
 - c) Minimize length of sanitary lateral and provide unobstructed connection to the sanitary main.
 - d) Interceptor tank elevation allows for minimum 2% slope for the sewage drainage from building to interceptor tank inlet.
 - e) Outlet of interceptor tank allows for minimum 0.5% slope for the SBS® lateral from interceptor tank outlet to the sanitary main.
2. Placement of interceptor – Backfilling and Compaction.
 - a) Backfilling and compaction shall follow the manufacturer's instruction.
 - b) Backfilling shall along sidewalls in 300 mm lifts.
 - c) Compaction shall meet 95% standard proctor density (S.P.D).
 - d) Property grading shall be sloped away from interceptor tank to avoid surface runoff entering.

3.4.2 Sanitary SBS® Mains, Laterals and SAPs

SBS® laterals, mains and SAPs will be constructed from HDPE DR17 pipe, and all connections are made through butt fusion or electro-fusion couplings, creating a permanent weld of equal or greater strength than the pipe itself.

The sewer mains will be constructed within the road right-of-way with minimum cover of 2.20 metres from the edge of the road to crown of the sewer. Sanitary laterals will be constructed to provide the most direct connection to the sewer main. Thermal insulation of pipe

sections with less than 2.2m burial depth will be provided as per city of Ottawa Standard Details W21 and W22 for frost protection.

SAPs will be housed in a cast iron enclosure complete with cover to protect the internal HDPE riser. The risers will be fitted with HDPE friction caps with breather holes to ensure system venting and prevent infiltration and debris from entering. Refer to Appendix F for SAP and collection system details.

3.4.3 CCTV Camera Inspection and Pressure Testing

Sewer main flushing should occur initially upon installation, followed by CCTV camera inspection. All components of the SBS® collection system will be tested in accordance with OPSS 409, 410 and 441 to ensure a watertight system. Low pressure air testing will be performed in accordance with OPSS 410.07.15.04.03, with no pressure drop. Sewer pipe segments where minimum 0.5m of clear vertical distance cannot be maintained in field to cross above watermains shall be pressure tested in accordance with Division 441 of the OPSS at a pressure of 350 kPa, with no leakage.

3.5 Operation and Maintenance

Maintenance requirements for the SBS® system are minimal, consisting of routine annual inspection and monitoring, as well as particular maintenance requirements for system components outlined in the following subsections. An operations and maintenance manual will be developed to document as-built information and to provide greater detail with respect to standard operations and maintenance requirements.

3.5.1 Interceptor Tanks

Sludge removal from residential interceptor tanks is typically required every 5 to 10 years, depending on the occupancy for each home. Access hatches on the interceptor tanks allow for routine inspection, pumping, and other maintenance activities. Sludge removal will be performed by a licensed septage hauler and disposed at an approved facility.

3.5.2 Sanitary SBS® Mains, Laterals and SAPs

Typical cleaning intervals for cleaning sewer mains and laterals range from 7 to 10 years. SAPs provide access to the collection system for inspection and cleaning. System flushing or pressure washing is performed using potable water delivered through fire hoses or through equipment from a commercial sewer maintenance company.

4.0 SUMMARY

The SBS® collection system has been designed for the proposed Phase 1B-2 development of 107 residential units. The proposed Phase 1B-2 SBS® collection system components are summarized as follows:

Residential Interceptor Tanks

- A total of 107 tanks with a minimum working capacity of 4,000 L each will be installed for each residential unit.
- Tanks will be installed at a minimum 1.5 m setback from buildings and a minimum 300 mm soil cover on top with access hatches to grade level.
- Tanks will provide a minimum hydraulic retention time of 2 days.

SBS® Collection System

- A total of approximately 850 m of SBS® laterals, all 75 mm diameter HDPE DR17 pipe at minimum 0.5% slope, will connect interceptor tanks to the sewer mains.
- An approximately 700 m of new SBS® mains in addition to existing SBS® mains ranging from 75-200 mm diameter HDPE DR17 will convey wastewater of the proposed development by gravity at minimum 0.15% slope to the downstream treatment plant.
- A total of 9 SAPs will be installed in proposed Phase 1B-2 with a maximum separation distance of 90 m.
- HDPE fusion/welding technologies to be used for all connections.

Operation and Maintenance Recommendations

- Routine monitoring of interceptor tanks and SBS® sewer collection system.
- Pump-out sludge from tanks when sludge level reaches 65% of liquid level, approximately every 5-10 years.
- Routine inspection of inverted siphon structure and flushing or pressure washing at intervals of 7-10 years.
- SBS® system flushing or pressure washing at intervals of 7-10 years.
- Partial CCTV inspection after 5-10 years of operation to develop maintenance program based on observed conditions.

Prepared By:



Yuxin Wang, EIT
Project Manager

Reviewed By:



Wilf Stefan, P.Eng.
COO

Appendix A: Plan View and Schematic of
Proposed SBS[®] Collection System

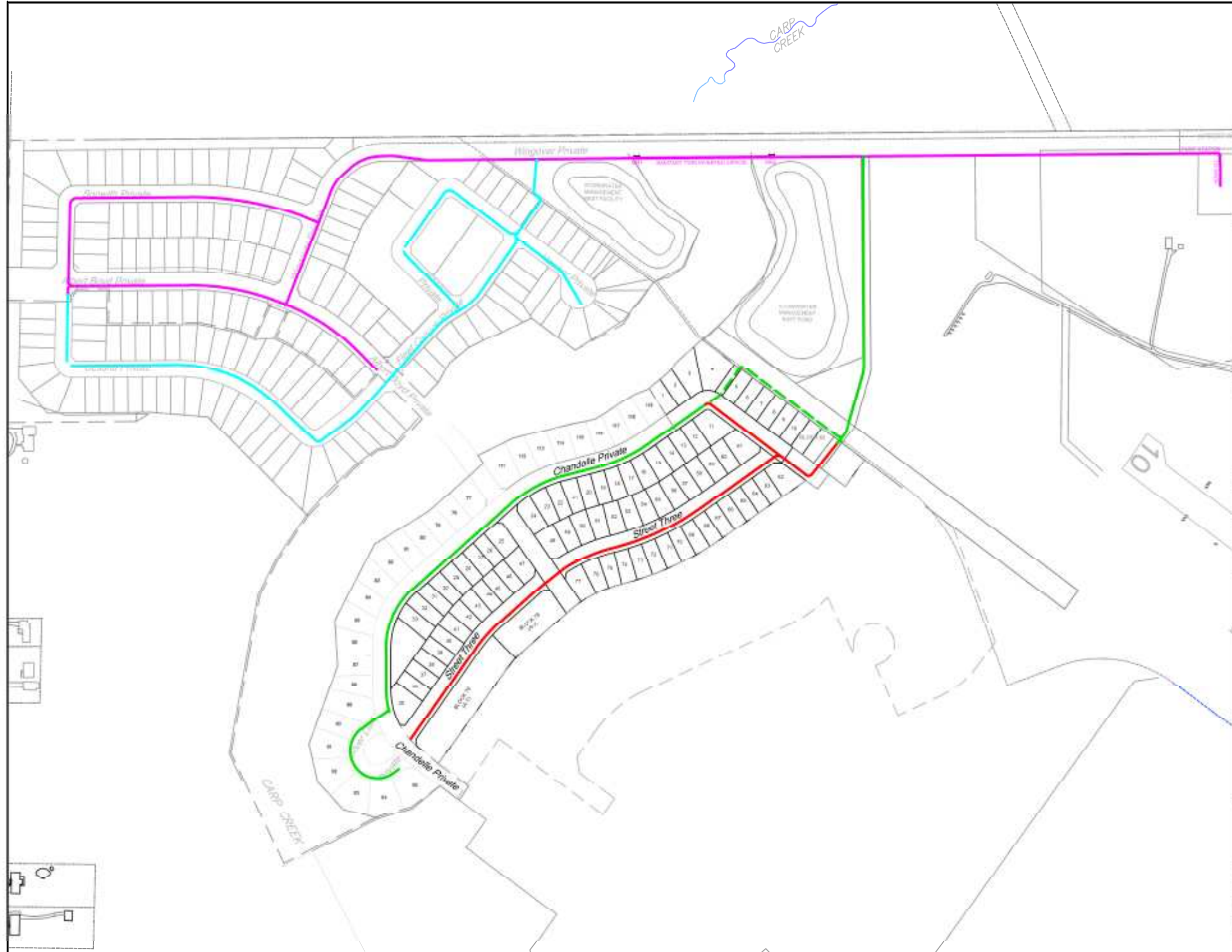

NOTES

LEGEND

- EXISTING PHASE 1A SBS™ MAIN
- EXISTING PHASE 2A SBS™ MAIN
- EXISTING PHASE 1B-1 SBS™ MAIN
- - - EXISTING PHASE 1B-1 SBS™ MAIN TO BE CUT OFF AND ABANDONED
- PROPOSED PHASE 1B-2 SBS™ MAIN

NOTES (IF ANY) SHOULD BE LISTED

NO	REVISIONS	DATE	INITIAL
01	ISSUED FOR REVIEW	JAN 2023	PR
02	ISSUED FOR CHANGES	JAN 2024	YW



1545 Claring Ave, Suite 300
 Ottawa, Ontario, K1Z 6P9
 Tel: (613) 588-6474 Fax: (613) 588-7478
 www.clearford.com

CLIENT
WEST CAPITAL DEVELOPMENTS
 CITY OF OTTAWA

DRAWING TITLE
**PLAN VIEW AND SCHEMATIC OF
 EXISTING & PROPOSED SBS™
 SANITARY SEWER SERVICING**

PROJECT NO: 0001	DATE: 23-01-2024	CONTRACT NO:
DESIGNED BY: YW		
DRAWN BY: YW		
CHECKED BY: JH		APPENDIX A
SCALE: AFD		

FILE PATH: P:\P\0001

Appendix B: Ontario MECC – ENVIRONMENTAL COMPLIANCE
APPROVAL

Content Copy Of Original



Ministry of the Environment and Climate Change
Ministère de l'Environnement et de l'Action en matière de changement
climatique

ENVIRONMENTAL COMPLIANCE APPROVAL

NUMBER 0961-A9UHS8
Issue Date: February 10, 2017

1514947 Ontario Inc.
1500 Thomas Argue Rd
Carp, Ontario
K0A 1L0

Site Location: Carp Airport Subdivision
1500 Thomas Argue Road
City of Ottawa
K0A 1L0

You have applied under section 20.2 of Part II.1 of the Environmental Protection Act, R.S.O. 1990, c. E. 19 (Environmental Protection Act) for approval of:

construction of private sewage treatment facilities for the collection, transmission, treatment and discharge of treated effluent to a dry ditch (which discharges to Carp Creek eventually to Carp River), designed at a Rated Capacity of 372,000 Litres per day and a maximum daily flow of 744,000 Litres per day, together with stormwater management facilities to serve the Phase I and Phase 2 residential development and business park at the West Capital Airpark located at the Carp Airport, in the City of Ottawa, consisting of the following:

Septic Tanks

- installation of clarifier tanks, each having a minimum volume of 4,000 L capacity complete with inlet and outlet hatches, hydraulic mixer and flow attenuator located on each residential lot and the communal hangar site, 9,000 L capacity for the wastewater treatment system/City park location, and a 45,000 L capacity tank for the community center site, discharging to the sanitary collection system, identified below;

Sewage Collection System

- a small diameter gravity sewer system (Small Bore Sewer (SBS) by Clearford Water Systems or equivalent), approximately 3,690 m in total length of collection mains with diameters ranging from 75 mm to 200 mm on the following streets:
 - Albert Boyd Private, 400 m;
 - Silver Dart Private 10 m;
 - Sopwith Private 360 m;
 - Wingover Private 985 m;
 - Easements 550 m;
 - Chandelle Private 670 m;
 - Tailslide Private 415 m;
 - TaxiwayE 300 m,

all complete with SAP type cleanouts;

- an inverted syphon, consisting of two (2) 100 mm diameter pipes, approximately 145 m in length , and one (1) 250 mm diameter sanitary sewer, approximately 30.7 m in length from the Wastewater Treatment Plant (described below), all discharging to the sanitary lift station, described below.
- one (1) 200mm diameter sanitary sewer, approximately 16.7m in length from the pump building, discharging to the equalization tanks located at the Wastewater Treatment Plan (described below);

Sanitary Lift Station

- a sanitary lift station, to convey sewage flows to the equalization tanks located at the wastewater treatment plant, and consisting of:
 - one (1) wet well with a minimum operating volume of approximately 1,840 L;
 - two (2) submersible pumps (one standby), each pump rated at 7.66 L/s at 6 m TDH, complete with a high liquid level alarm, and discharging via a 75 mm diameter forcemain to a 200 mm diameter sanitary sewer, approximately 21.6 m in length, discharging to the equalization tanks at the Wastewater Treatment Plant (described below);
 - one (1) covered control panel.

Wastewater Treatment Plant

A modular package type wastewater treatment system rated at an average daily flow of 186 m³/day for Phase 1 of the development and an additional average daily flow of 186 m³ /day for Phase 2 of the development (progressing to average daily flow of 910 m³/day at full build-out in Phase 5 in future), consisting of the following:

Phase 1

- an equalization tank system (multiple tanks) with a volume of 103 m³ for Phase 1 of the development (309 m³ at full build-out in Phase 5 in future), complete with an ultrasonic level transmitter to control pump operation and back-up high level alarm float switch.
- two rotary lobe blowers for aeration of the equalization tank system, as required.
- two variable speed pumps (one duty and one standby) to transfer wastewater through the screening system.
- two rotary brush screens (one duty and one standby) with 2 mm openings, each with a capacity of approximately 983 L/min, equipped with water level sensor and two feed forwards pumps (one duty and one standby).
- an aerobic tank with a storage volume of approximately 41 m³, equipped with two rotary lobe blowers (one duty and one standby) for fine bubble aeration, complete with dissolved oxygen and pH transmitters, and chemical metering pumps to feed sodium hydroxide for pH adjustment (as needed) and alum to promote flocculation of suspended solids (as needed).
- a tank level transmitter and high level float alarm switch in aerobic tank as well as two centrifugal submersible feed pumps (one duty and one standby) rated at 12 L/s at 4.6 m TDH to pump wastewater to the membrane bioreactor.
- a membrane reactor system consisting of one membrane tank (approximate volume of 11.4 m³) and two flat sheet membrane modules (newterra MB3-2 MicroClear) equipped with two permeate extraction pumps (one duty and one standby), complete with an overflow return line to the aerobic tank.
- two blowers (one duty and one standby) within the membrane reactor system for scouring of the membrane modules.
- a sludge holding tank having an approximate volume of 7 m³ complete with a sludge dewatering system with mixing tank for polymer addition and dewatering press equipped with water return line to

the equalization tank, with dried sludge stored in an outdoor bin.

- an effluent flow meter prior to effluent discharge to an onsite dry ditch via a 200mm diameter sanitary sewer, approximately 31.7m in length.

Phase 2

- a second equalization tank with a volume of 103 m³ for Phase 2 of the development.
- an aerobic tank with a storage volume of approximately 41 m³, equipped with two rotary lobe blowers (one duty and one standby) for fine bubble aeration, complete with dissolved oxygen and pH transmitters, and chemical metering pumps to feed sodium hydroxide for pH adjustment (as needed) and alum to promote flocculation of suspended solids (as needed).
- a tank level transmitter and high level float alarm switch in aerobic tank as well as two centrifugal submersible feed pumps (one duty and one standby) rated at 12 L/s at 4.6 m TDH to pump wastewater to the membrane bioreactor.
- a membrane reactor system consisting of one membrane tank (approximate volume of 11.4 m³) and two flat sheet membrane modules (newterra MB3-2 MicroClear) equipped with two permeate extraction pumps (one duty and one standby), complete with an overflow return line to the aerobic tank.
- two blowers (one duty and one standby) within the membrane reactor system for scouring of the membrane modules.

Stormwater Management Facilities

Construction of stormwater management works related to the construction of the Wastewater Treatment and Water Storage Facility at the West Capital Airpark located at the Carp Airport, in the City of Ottawa, to provide on-site stormwater quality protection and erosion control and to attenuate post-development peak flows to pre-development release rates for all storm events up to and including the 100-year storm event for a catchment area of 0.489 hectares of industrial area, discharging to the roadside ditch along Wingover Private and ultimately discharging to Carp Creek, consisting of the following:

- enhanced grassed swales, located along the east, south and west property boundaries (180m total) designed to convey runoff from storms up to and including the 100-year return period, with a trapezoidal cross-section, bottom slope of approximately 0.50%, bottom width of 0.75 metres, and 3:1 side slopes, discharging to two ditch inlet catch basins (DICB A and B);

- stormwater management facility (catchment area 0.489 hectares): Two (2) dry swales (WSW and ESW), located along the east, south and west property boundaries, each having a total storage volume of 27.90 m³ and 27.14 m³ respectively at a depth of 0.30 m, with side slopes of 3H:1V (maximum) and a bottom slope of approximately 0.5%, complete with two inlet control structures (DICB A and DICB B), receiving inflow from enhanced grassed swales; two multi-staged outlet control structures, Tempest 115mm orifice (installed in outlet pipe of DICB A) controlling flows to 17.9 L/s and a Tempest 90mm orifice (installed in the outlet pipe of DICB B) controlling flows to 11.1 L/s during the 100-year event, connecting to a riprap lined swale, discharging to the Wingover Private roadside ditch and ultimately discharging to Carp Creek;

- including erosion/ sedimentation control measures during construction and all other controls and appurtenances essential for the proper operation of the aforementioned Works,

all other controls, electrical equipment, instrumentation, piping, pumps, valves and appurtenances essential for the proper operation of the aforementioned sewage works;

all in accordance with the submitted supporting documents listed in **Schedule B**.

Appendix C: Ontario MOE – NETE Certificate

CERTIFICATE

OF TECHNOLOGY ASSESSMENT

Clearford Small Bore Sewer™ System

The Ontario Ministry of the Environment has reviewed the Clearford Small Bore Sewer™ System (SBS™). Based on a review of the data and the information submitted in support of the technology (see Notable Aspects and Appendix) the ministry concurs that the system, if applied according to design criteria subject to site specific considerations, can be a viable sewage collection and pre-treatment system suitable for application under Ontario conditions in accordance with MOE Design Guidelines for Sewage Works, 2008.

Municipal applications of this technology in Ontario have already received site specific approval and historical performance data has shown agreement with the recommended general design criteria. Installation and operation of the SBS™ system requires individual Municipal or Provincial approval on a site specific basis, as applicable.

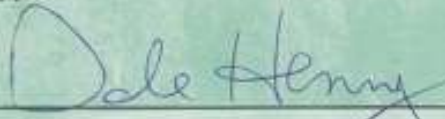

Dale Henry, Director

Standards Development Branch
Ontario Ministry of the Environment
(July 2009)

New Environmental Technology Evaluation Program

Promoting the development and application of new environmental technologies



Clearford Small Bore Sewer™ System

Notable Aspects of the Technology:

- √ The Clearford Small Bore Sewer™ (SBS™) system is distinctly different from the traditional gravity sewers and has the following recommended key design criteria:
 - √ Average daily flowrate of 200 to 225 litres per capita per day [L/(c·d)].
 - √ Minimum design cleansing velocity of 0.15 m/s.
 - √ Minimum nominal pipe diameter of 75 mm.
 - √ Design zero infiltration flow.
 - √ Design peaking factor of 2.
- √ The SBS™ system utilizes an on-site SBS™ Clarifier which provides solids separation, solids storage and associated anaerobic digestion treatment. The effluent from the SBS™ Clarifier flows by gravity to the small diameter gravity sewers (SDGS) pipe network. The SDGS convey effluent from an interceptor tank or SBS™ Clarifier, to pumping station(s) or sewage treatment facility. These SDGS systems convey only clarified effluent (significant lower solids) and thus require smaller diameter pipes and reduced slopes (or can follow the surface contour of the land) reducing the amount of excavation and construction costs.
- √ The SBS™ Clarifier consists of a vacuum tested two-chamber tank, with adjustable access for clean-out. The primary compartment comprises 80% of the total Clarifier tank volume which provides for increased solids storage and digestion. Clarifier tanks are installed to service each household, block of homes or commercial establishments. The recommended pump-out maintenance cycle is up to 10 years for an average density household. At this pump-out frequency there is approximately a 50% reduction in sludge volume due to anaerobic digestion. Proper disposal of collected septage from SBS™ Clarifiers must be performed by licensed septage haulers, with local authorities enforcing powers for hygiene control.
- √ The SBS™ Clarifier is vented in two directions: the receiving compartment vents back through the house/building plumbing stack and the discharge end vents forward through the collection system by a combination of building stacks, earth (subsurface) venting and through installed air vents within the pipe network.
- √ The SBS™ collection system consists of fused-joint high density polyethylene (HDPE) piping for its collection mains, laterals and clean-out access points. Ventilation on-site and throughout the collection system at critical junctures is required to enable flow with a minimum gradient. The SBS™ collection system is not alignment sensitive but requires that the overall net gradient is positive if a minimum slope of 0.15% is met. The SBS™ collection system has a recommended flushing cycle every 7 to 10 years through the use of strategically designed clean-outs/flush points, called

system access points (SAP), which follows the Clarifier pump-out schedule. The SBS™ collection system, with the use of HDPE materials, permits the utilization of trenchless technology for installing mains and laterals. Air release vents are required at or slightly downstream of summits in sewer profiles. Since all sanitary sewers generate some odours at various points in the system, the pipe network of the SBS™ collection system that conveys Clarifier effluent has odour control installed at all access points where necessary. Generally, odour control is effectively managed by the use of subsurface venting, well designed drop inlets and other control measures.

- √ The SBS™ collection system uses fused-joint high density polyethylene (HDPE) pipes in accordance with manufacturers' recommendations and installation specifications. Pipes must be buried deep enough to prevent damage from anticipated earth and vehicle loading and below the frost line to prevent freezing.
- √ The general design criteria for the Small Bore Sewer™ system include:
 - 1) Per capita average daily sewage flow range of 200 to 225 L/(c·d), plus zero infiltration allowance, with the use of fused-joint HDPE collection system and the use of water-tight, vacuum tested SBS™ Clarifier with sealed inlet and outlet components.
 - 2) A minimum cleansing velocity of 0.15 m/s is recommended.
 - 3) Whenever possible, it is desirable to use actual flow data for design purposes, however in the absence

of flow data a peak hour design factor of 2 is recommended.

- 4) Each segment of sewer is analysed by the Hazen-Williams or Manning equations to determine if the pipe is adequately sized and sloped to conduct the peak design flow.
- 5) Typical municipal SBS™ Clarifier effluent characteristics for BOD₅, TSS, TKN and TP are 120, 40, 30 and 6 mg/L, respectively, based on typical removal rates. There is no record of the SBS™ system clogging.
- 6) The SBS™ collection system pipes must be buried deep enough to prevent damage from anticipated earth and vehicle loading and below the frost line to prevent freezing.
- 7) The SBS™ collection system is comprised of the following components: the HDPE pipe, which has a 90 year design-life, is connected via thermal fusion methodologies to the concrete Clarifier tank, which has a 35+ year design-life. All components are corrosion resistant. Discharges to gravity sewer interceptors or treatment facilities will typically be made through drop inlets below the liquid level to minimize odours.
- 8) Mainline clean-outs are generally spaced up to 250 metres apart. Unlike maintenance holes, clean-outs are not required at every change in alignment or elevation. Clean-outs are sealed and do not

allow for inflow, unlike maintenance holes.

- 9) Primary clarification is not generally required to treat Clarifier tank liquid effluent and direct discharge to secondary treatment systems is generally appropriate. All currently available treatment systems, such as sand filters, aerobic treatment system, and membrane based treatment systems, are generally effective in downstream treatment of SBS™ effluent; treatment technology selection is generally subject to site specific discharge parameters' consideration. Generally odour control at the headwork of a sewage treatment plant should receive attention.
- √ Many SDGS systems using similar principles of design to the Small Bore Sewer™ system have been installed in Australia and the United States since the 1960s and 1970s respectively. The SBS™ system provides improvements to the traditional SDGS systems by the use of horizontal drilling installation techniques, improved materials and advancements in quality control measures.
- √ The Small Bore Sewer™ system has been approved for construction in Ontario, in the Township of Cramahe in 2003, in the Village of Wardsville in 2000 and in Field Township in 1989; subsequent systems have been installed in Alberta, British Columbia and Ontario. The construction of the sewage works was approved by the MOE Environmental Assessment and Approvals Branch (EAAB) under the Ontario Water Resources Act (OWRA).
- In the Village of Wardsville (part of the Municipality of Southwest Middlesex)**
- √ The approved Small Bore Sewer™ system serves 151 single family homes, a golf course, nursing home and other municipal establishments with on-site SBS™ Clarifiers ranging in size from 3600 to 45,000 litres.
- √ The collection system consists of about 4,500 metres of 75 mm diameter HDPE pipes and larger diameter pipes. Performance data from 2001 to 2005 on the Small Bore Sewer™ system provides confirmation that the most stringent recommended general design criteria have been met.
- √ Field examination of 29 residential two-chamber septic tanks with 3600 L volume, serving 2.0 adults per site on average, had been in operation for approximately 7 years without septage removal and the following has been reported:
- 1) An average 1st chamber sludge plus scum volume of 110 L/yr.
 - 2) An average 2nd chamber sludge plus scum volume of 14 L/yr.
 - 3) Average pump out period for the first chamber based on 30% sludge tank volume is 10 ± 7 years.
 - 4) The average chemical concentrations of the sludge in the 1st chamber were calculated and reported to be:
TS = 49 ± 18 g/L;
BOD₅ = 5760 ± 4000 mg/L;
TKN = 1025 ± 73 mg/L; and,
pH = 6.7 ± 0.3 .
- √ Based on a 6 month monitoring program from February to August 2008 of the Wardsville Pumping Station, the following sewage generation rates were reported:

- 1) Average daily flow of 157 L/c/d (weekdays) with a 1.8 peaking factor.
 - 2) Average daily flow of 142 L/c/d (weekends) with a 1.8 peaking factor.
 - 3) These sewage generation rates reflect the use of fused HDPE pipes and the lack of manholes and lateral connections which reduce infiltration and inflow (I/I)
- √ Reduced I/I and resulting lower sewage generation rates, as reported, may eliminate bypass occurrences or reduce downstream wastewater treatment plant upgrades or expansions.

In the Township of Field

- √ The approved Small Bore Sewer™ system was installed in the Township of Field in 1989 to serve 35 single family homes and other municipal establishments with on-site SBS™ Clarifiers of 2,700 to 4,600 litres, serving a total of 117 equivalent population. An average design value of 225 L/(c·d) with a peaking factor of 2 was used and a minimum HDPE pipe size of 75 mm diameter was adopted. Three pumping stations were required and each used 50 mm diameter HDPE forcemains.
- √ At the Field installation the frost penetration was investigated and a minimum design depth of 1.1 metre for pipe burial was adopted with provision for 50 mm jacket insulation and heat tracing in well travelled bare road sections. Shallower and narrower pipe trenches were used as compared to conventional sanitary sewers.
- √ The actual per capita sewage flows once infiltration/inflow sources had been eliminated ranged from 90 to 130

L/(c·d). Some odour issues developed and were resolved by the proper use of drop inlets, soil odour filters and a cover at the sewage treatment plant.

- √ Performance and evaluation reports in 1993 and 1995 on the performance of the Small Bore Sewer™ system in the Township of Field indicated that the recommended General Design Criteria were met during the evaluation period.
- √ Both Field and Wardsville used extended aeration treatment plants without primary clarification to treat the SBS™ effluent.
- √ Operation at new sites requires a Certificate of Approval (C of A) under the Ontario Water Resources Act (OWRA). However, the C of A is not required under Section 53(6)(b) of the OWRA when the SBS™ system is used on private property and connects to a municipal sewer.

APPENDIX

Documents reviewed:

1. PowerPoint presentation dated May 2006.
2. "Clearford Industries Inc. Wastewater Systems Division", PCL National Partner, promotional brochure.
3. Letter from EAAB on Certificate of Approval No. 3-0013-96-PE dated July 22, 1996, signed by Mirek Tybinkowski.
4. Certificate of Approval for The Corporation of the Village of Wardsville, No. 4608-4FNLG6 dated January 24, 2000.

5. Cover of MOE publication entitled, "An Introduction to Communal Sewage Systems" with reference to "grade sewers".
6. A 46 page design report entitled, "TAG Technical Note No. 14, The Design of Small Bore Sewer Systems" by R. Ottis and D. D. Mars, Technical Advisory Group (TAG).
7. National Small Flows Clearinghouse, Pipeline, Fall 1996, Vol. 7, No. 4.
8. Article from "The Ontario Technologist", Trenchless Technology: Working Underground Without Going Underground by Bill Garibaldi, CET, September/October, 1997.
9. National Small Flows Clearinghouse, Pipeline, Fall 2000, Vol. 11, No. 4.
10. Small Flows Quarterly, Spring 2001, Vol. 2, No. 2.
11. "Decentralized Systems Technology Fact Sheet, Small Diameter Gravity Sewers", by the U.S. EPA Agency, Office of Water, Washington D.C., EPA 832-F-00-38, September, 2000.
12. Technical paper entitled, "A comparison of sewer reticulation system design standards gravity, vacuum and small bore sewers", by C. J. Little, first presented at the 2004 Water Institute of South Africa (WISA) Biennial Conference, Cape Town, South Africa, 2-6 May 2004.
13. Two page summary on the Township of Field, Small Diameter Effluent Sewers full scale installation of 35 residences, a recreational facility and a municipal garage.
14. Eight page summary report entitled, "Small Diameter Effluent Sewers, Summary Report, Experiences at Township of Field", by C. W. Brink, P. Eng., Engineering Resources, 1995.
15. Eighteen page report entitled, "Monitoring and Evaluation Report, Small Bore Sewers, Village of Field, Ontario", prepared for the MOE and CETEC North Committee, MOE project No. 3-0515, by R. W. Connelly Associates Inc., Consulting Engineers and Planners, Carp, Ontario, May 2003.
16. Article in Municipal World, June 2004 by Jim Williams entitled, "Small bore sewer solution preserves development opportunities for Cramahe Township".
17. Letter from C. W. Brink of OCWA dated June 24, 1994 identifying the cost benefits of SBS, need to control infiltration and integration of STP with collection system, based on Twp of Field experience located near North Bay, Ontario.
18. Two letters of endorsement of the SBSTM from the Village of Wardsville related to significant cost savings. The letters were from the village Reeve and Project Coordinator.
19. Three letters endorsing the SBSTM system by GE-Zenon, Seprotech and Waterloo Biofilter. These groups provide sewage treatment systems

Appendix D: Interceptor Tank Details

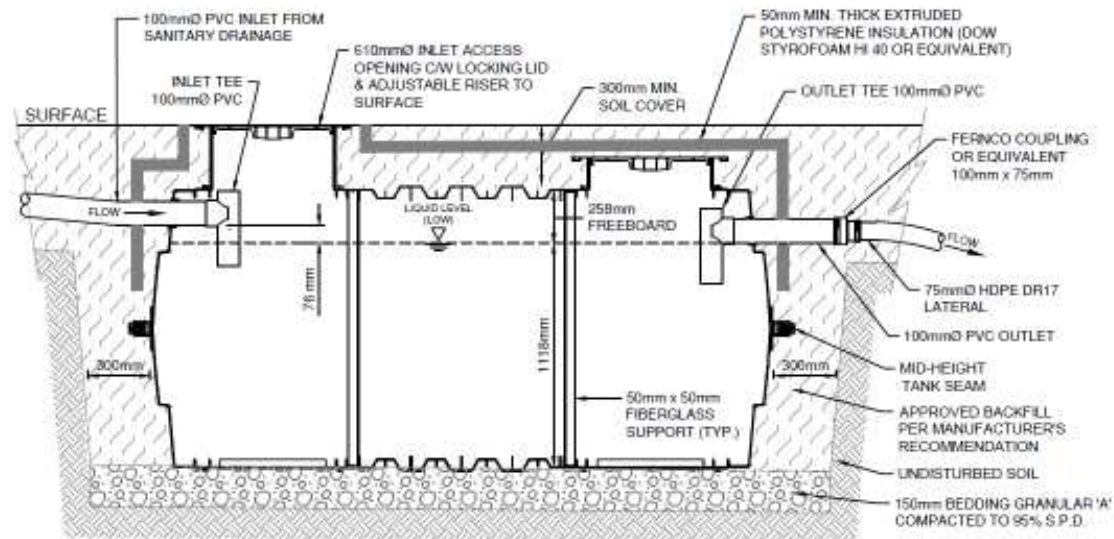

SECTION A-A WITH EXCAVATION DETAIL

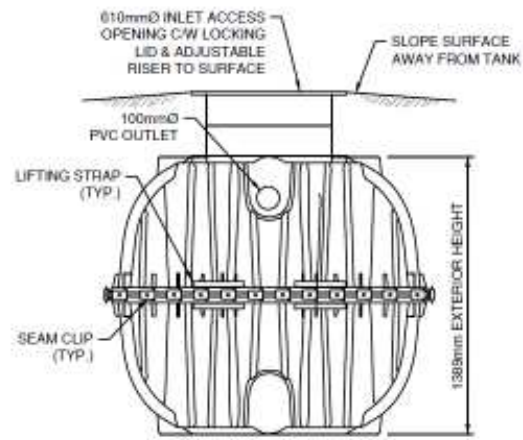

END VIEW

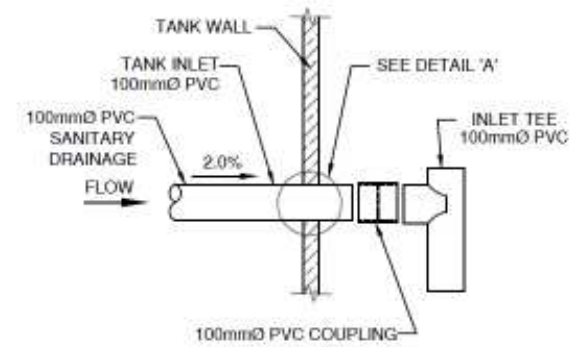

CLEARFORD INTERCEPTOR TANK INLET DETAIL
N.T.S.

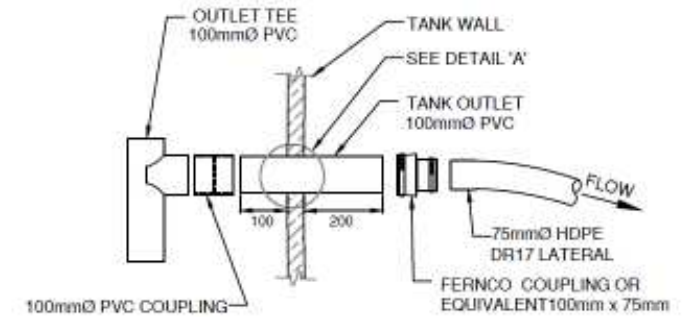

CLEARFORD INTERCEPTOR TANK OUTLET DETAIL
N.T.S.

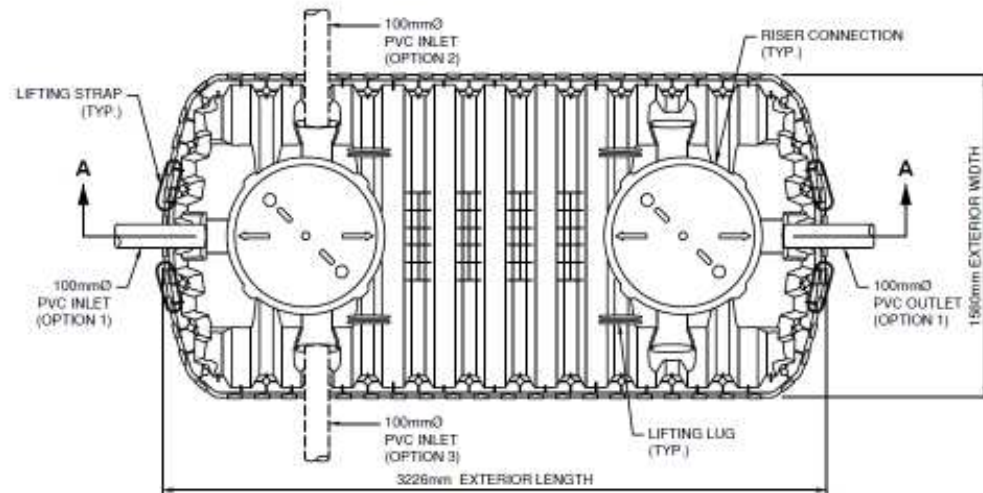

TOP VIEW

CLEARFORD INTERCEPTOR TANK DETAIL (TYP.)
N.T.S.

NOTES:

1. ALL DIMENSIONS ARE IN MILLIMETRES UNLESS OTHERWISE NOTED.
2. PVC PIPES AND FITTINGS TO BE SDR 35 PER CSA B182.1.
3. ALL PVC PARTS TO BE GLUED TOGETHER WITH APPROPRIATE SOLVENT CEMENT AND PRIMER.
4. CONTRACTOR SHALL TO PROVIDE SHOP DRAWINGS OF PVC COMPONENTS AND COUPLINGS.

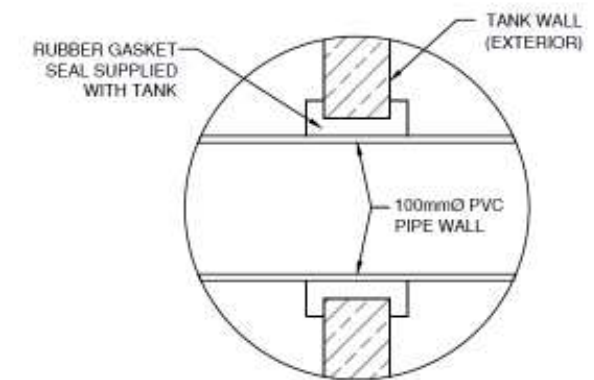

DETAIL 'A' - RUBBER GASKET PIPE SEAL
N.T.S.

NOTES

LEGEND

NO.	REVISIONS	DATE	INITIAL	NOT VALID UNTIL SIGNED AND DATED
1	ISSUED FOR APPROVAL	03/07/2010	WS	

PROJECT NO.	9001
DATE:	29/11/2010
DESIGNED BY:	YM
DRAWN BY:	YM
CHECKED BY:	MS
SCALE:	N.T.S.

CONTRACT NO.	
DRAWING NO.	APPENDIX C

CLIENT
WEST CAPITAL DEVELOPMENT
CITY OF OTTAWA

DRAWING TITLE
CLEARFORD INTERCEPTOR TANK DETAILS

CLEARFORD
WATER SYSTEMS INC.

515 Legget Drive, Suite 108
Ottawa, Ontario, K2K 3G4
Tel: (613) 599-6474 Fax: (613) 599-7478
Toll free: (866) 231-1104
www.clearford.com

Appendix E: SBS[®] Sanitary Sewer Design Sheet

06001-West Capital Airpark (Carp Airpark) Residential Development: Clearford SBS® Sanitary Sewer Design Sheet

Phase	Seg. #	Location						Cumulative			Sewer Parameters						Flow Design				Comments/Areas																	
		1		2		3		4		5		6		7		8		9		10		11		12		13		14		15		16		17		18		
		Location	From (Label)	From Chainage	From Proposed Grade	To (Label)	To Chainage	To Proposed Grade	Residential Connections	Equivalent Connections	Cumulative Equivalent Connections	Equivalent Cumulative Pop.	Design Flow, Qp [L/s]	Pipe Length [m]	U/S Invert [m]	D/S Invert [m]	Proposed Sewer Slope [%]	Pipe Size [mm]	Pipe Capacity Qf [L/s]	Capacity Ratio Qp/Qf		Velocity Ratio Vp/Vf	Full Flow Velocity [m/s]	Peak Design Velocity [m/s]														
EXISTING PHASE 1A	1	Sopwith Pvt	SAP 2-A	2+	79.55	117.53	WYE	1+	87.60	117.09	9	9	30.60	0.205	90.00	115.49	115.03	0.51%	75	1.715	0.12	0.54	0.39	0.21	Start of run													
	2	Alberta Body Pvt	WYE	1+	87.60	117.09	SAP 1-A	1+	100.00	116.98	0	17.00	57.80	0.388	12.40	115.03	114.93	0.81%	75	2.154	0.18	0.63	0.49	0.31	Add seg. #88 (Phase 2A)													
	3	Alberta Body Pvt	SAP 1-A	1+	100.00	116.98	EXPANDER	1+	150.00	116.52	2	19.00	64.60	0.434	50.00	114.93	114.44	0.95%	75	2.333	0.19	0.63	0.53	0.33														
	4	Alberta Body Pvt	EXPANDER	1+	150.00	116.52		1+	269.04	116.15	15	34.00	115.60	0.776	119.04	114.44	114.04	0.33%	100	2.983	0.26	0.71	0.38	0.27														
	5	Alberta Body Pvt		1+	269.04	116.15	WYE	1+	324.94	116.27	5	39.00	132.60	0.890	55.90	114.04	113.74	0.54%	100	3.802	0.23	0.68	0.48	0.33	Junction													
	6	Alberta Body Pvt	SAP 1-D	1+	448.60	116.23		1+	417.05	116.06	2	2.00	6.80	0.046	31.55	114.22	114.09	0.42%	100	3.353	0.01	0.25	0.43	0.11	Start of run													
	7	Alberta Body Pvt		1+	417.05	116.06	WYE	1+	324.94	116.27	9	11.00	37.40	0.251	92.11	114.09	113.74	0.38%	100	3.184	0.08	0.48	0.41	0.19														
	8	Sopwith Pvt	SAP 2-B	2+	90.00	117.60		2+	333.18	115.95	24	24	81.60	0.548	243.18	115.36	113.67	0.69%	75	1.999	0.27	0.72	0.45	0.33	Start of run													
	9	Sopwith Pvt		2+	333.18	115.95	WYE	2+	365.79	115.75	1	25	85.00	0.571	32.61	113.67	113.44	0.71%	75	2.014	0.28	0.73	0.46	0.33														
	10	Wingover Pvt	SAP 7-A	6+	-14.20	116.30	WYE	6+	-3.30	116.30	0	0.00	0.00	0.000	10.90	113.87	113.73	1.28%	150	17.260	0.00	0.00	0.98	0.00	Start of run													
	11	Wingover Pvt	WYE	6+	-3.30	116.30		6+	10.00	116.30	0	51.00	173.40	1.164	13.30	113.73	113.57	1.20%	150	16.704	0.07	0.46	0.95	0.43	Add seg. #5,#7 & #89 (Phase 2A)													
	12	Wingover Pvt		6+	10.00	116.30	WYE	6+	89.63	115.91	3	54.00	183.60	1.233	79.63	113.57	113.39	0.23%	150	7.241	0.17	0.62	0.41	0.26														
	13	Wingover Pvt	WYE	6+	89.63	115.91		6+	139.48	115.46	5	84.00	285.60	1.917	49.85	113.39	113.09	0.60%	150	11.814	0.16	0.61	0.67	0.41	Add seg. #9													
	14	Wingover Pvt		6+	139.48	115.46		6+	171.36	115.30	2	86.00	292.40	1.963	31.88	113.09	112.95	0.44%	150	10.092	0.19	0.64	0.57	0.37														
	15	Wingover Pvt		6+	171.36	115.30		6+	230.98	115.00	0	86.00	292.40	1.963	59.62	112.95	112.87	0.14%	200	12.175	0.16	0.61	0.39	0.24														
	16	Wingover Pvt		6+	230.98	115.00		6+	233.15	114.99	0	86.00	292.40	1.963	2.17	112.87	112.60	12.44%	200	115.692	0.02	0.25	3.68	0.93														
	17	Wingover Pvt		6+	233.15	114.99	WYE	6+	368.59	114.32	0	86.00	292.40	1.963	135.44	112.60	111.92	0.50%	200	23.240	0.08	0.49	0.74	0.36														
	18	Wingover Pvt	WYE	6+	368.59	114.32		6+	400.00	114.16	0	207.00	703.80	4.725	31.41	111.92	111.76	0.51%	200	23.409	0.20	0.65	0.75	0.49	Add seg. #100 (Phase 2A)													
	19	Wingover Pvt		6+	400.00	114.16	MH 1	6+	475.00	114.00	0	207.00	703.80	4.725	75.00	111.76	111.57	0.25%	200	16.508	0.29	0.73	0.53	0.38	Invert Siphon Inlet													
	20	Wingover Pvt	MH 1	6+	475.00	114.00	MH 2	6+	620.01	113.21	0	207.00	703.80	4.725	145.01	111.57	110.78	0.54%	100	7.625	0.62	0.92	0.49	0.45	Invert Siphon parallel line													
	21	Wingover Pvt	MH 2	6+	620.01	113.21		6+	715.96	112.93	0	207.00	703.80	4.725	95.95	110.78	110.25	0.55%	200	24.376	0.19	0.64	0.78	0.50	Inverted Siphon Outlet													
	22	Wingover Pvt		6+	715.96	112.93	WYE	6+	720.00	112.91	0	207.00	703.80	4.725	4.04	110.25	110.10	3.71%	200	63.199	0.07	0.48	2.01	0.97														
	23	Wingover Pvt	WYE	6+	720.00	112.91		6+	949.92	111.40	0	2.03	346.03	1339.00	8.989	229.92	110.10	109.00	0.48%	200	22.686	0.40	0.80	0.72	0.58	Add seg.#86(Phase 1B)												
	24	Wingover Pvt		6+	949.92	111.40	PS1	7+	136.36	111.90	0	346.03	1339.00	8.989	186.44	109.00	108.44	0.30%	200	17.975	0.50	0.87	0.57	0.50														
EXISTING PHASE 1B-1	25	Chandelle Pvt	CAP	8+	118.94	118.10	SAP 8-A	8+	120.53	118.07	0	0	0.00	0.000	1.59	115.80	115.79	0.57%	75	1.805	0.00	0.00	0.41	0.00	Start of run													
	26	Chandelle Pvt	SAP 8-A	8+	120.53	118.07		8+	118.46	118.16	0	0	0.00	0.000	2.07	115.79	115.79	0.19%	75	1.054	0.00	0.00	0.24	0.00														
	27	Chandelle Pvt		8+	118.46	118.16		8+	101.80	118.08	1	1	3.40	0.023	16.66	115.79	115.71	0.43%	75	1.577	0.01	0.25	0.36	0.09														
	28	Chandelle Pvt		8+	101.80	118.08		8+	87.00	118.06	1	2	6.80	0.046	14.80	115.71	115.64	0.53%	75	1.752	0.03	0.33	0.40	0.13														
	29	Chandelle Pvt		8+	87.00	118.06		8+	71.60	117.98	1	3	10.20	0.068	15.40	115.64	115.56	0.51%	75	1.718	0.04	0.37	0.39	0.14														
	30	Chandelle Pvt		8+	71.60	117.98		8+	59.40	117.92	1	4	13.60	0.091	12.20	115.56	115.52	0.27%	75	1.247	0.07	0.48	0.28	0.14														
	31	Chandelle Pvt		8+	59.40	117.92		8+	43.50	117.84	0	5	17.00	0.114	15.90	115.52	115.51	0.10%	75	0.761	0.15	0.59	0.17	0.10														
	32	Chandelle Pvt		8+	43.50	117.84		8+	36.20	117.81	1	6	20.40	0.137	7.30	115.51	115.50	0.12%	75	0.842	0.16	0.61	0.19	0.12														
	33	Chandelle Pvt		8+	36.20	117.81		8+	20.30	117.73	0	6	20.40	0.137	15.90	115.50	115.43	0.43%	75	1.569	0.09	0.49	0.36	0.17														
	34	Chandelle Pvt		8+	20.30	117.73	WYE	8+	4.15	117.76	0	6	20.40	0.137	16.15	115.43	115.42	0.04%	75	0.462	0.30	0.73	0.10	0.08	To chainage 9+													
	35	Chandelle Pvt	CAP	9+	463.89	117.81	SAP 9-C	9+	465.00	117.81	0	0	0.00	0.000	1.12	115.44	115.44	0.54%	75	1.759	0.00	0.00	0.40	0.00	For Future Connections													
	36	Chandelle Pvt	SAP 9-C	9+	465.00	117.78	WYE	9+	467.70	117.76	0	0	0.00	0.000	2.70	115.44	115.42	0.52%	75	1.727	0.00	0.00	0.39	0.00	Start of run (Phase 1B)													
	37	Chandelle Pvt	WYE	9+	467.70	117.76		9+	471.66	117.77	1	7	23.80	0.160	3.96	115.42	115.354	1.77%	75	3.189	0.05	0.43	0.72	0.31	Add seg. #34													
	38	Chandelle Pvt		9+	471.66	117.77		9+	490.96	117.65	0	7	23.80	0.160	19.30	115.35	115.30	0.28%	75	1.280	0.12	0.56	0.29	0.16														
	39	Chandelle Pvt		9+	490.96	117.65		9+	515.79	117.52	1	8	27.20	0.183	24.83	115.30	115.17	0.50%	75	1.702	0.11	0.52	0.39	0.20														
	40	Chandelle Pvt		9+	515.79	117.52		9+	534.14	117.43	1	9	30.60	0.205	18.35	115.17	115.09	0.46%	75	1.623	0.13	0.56	0.37	0.21														
	41	Chandelle Pvt		9+	534.14	117.43	SAP 9-D	9+	547.53	117.37	1	10	34.00	0.228	13.39	115.09	115.04	0.37%	75	1.451	0.16	0.60	0.33	0.20														
	42	Chandelle Pvt	SAP 9-D	9+	547.53	117.37		9+	556.70	117.32	0	10	34.00	0.228	9.17	115.04	114.98	0.71%	75	2.019	0.11	0.54	0.46	0.25														

06001-West Capital Airpark (Carp Airpark) Residential Development: Clearford SBS® Sanitary Sewer Design Sheet

Phase	Seg. #	Location							Cumulative					Sewer Parameters				Flow Design				Comments/Areas			
		1	2		3		4	5	6	7	8	9	10	11	12	13	14	15	16	17	18				
		Location	From (Label)	From Chainage	From Proposed Grade	To (Label)	To Chainage	To Proposed Grade	Residential Connections	Equivalent Connections	Cumulative Equivalent Connections	Equivalent Cumulative Pop.	Design Flow, Qp [L/s]	Pipe Length [m]	U/S Invert [m]	D/S Invert [m]	Proposed Sewer Slope [%]	Pipe Size [mm]	Pipe Capacity Qf [L/s]	Capacity Ratio Qp/Qf	Velocity Ratio Vp/Vf	Full Flow Velocity [m/s]	Peak Design Velocity [m/s]		
	45	Chandelle Pvt		9+ 583.07	117.19		9+ 592.38	117.14	1		14	47.60	0.320	9.31	114.83	114.78	0.49%	75	1.686	0.19	0.63	0.38	0.24		
	46	Chandelle Pvt		9+ 592.38	117.14		9+ 599.25	117.11	1		15	51.00	0.342	6.87	114.78	114.74	0.63%	75	1.898	0.18	0.63	0.43	0.27		
	47	Chandelle Pvt		9+ 599.25	117.11		9+ 608.55	117.06	1		16	54.40	0.365	9.30	114.74	114.72	0.20%	75	1.084	0.34	0.76	0.25	0.19		
	48	Chandelle Pvt		9+ 608.55	117.06		9+ 617.48	117.02	1		17	57.80	0.388	8.93	114.72	114.67	0.55%	75	1.777	0.22	0.66	0.40	0.26		
	49	Chandelle Pvt		9+ 617.48	117.02	SAP 9-E	9+ 631.86	116.95	1		18	61.20	0.411	14.38	114.67	114.64	0.19%	75	1.058	0.39	0.79	0.24	0.19		
	50	Chandelle Pvt	SAP 9-E	9+ 631.86	116.95		9+ 669.88	116.76	5		23	78.20	0.525	38.02	114.64	114.48	0.43%	75	1.560	0.33	0.76	0.36	0.27		
	51	Chandelle Pvt		9+ 669.88	116.76	SAP 9-F	9+ 717.36	116.52	4		27	91.80	0.616	47.49	114.48	114.26	0.46%	75	1.621	0.38	0.79	0.37	0.29		
	52	Chandelle Pvt	SAP 9-F	9+ 717.36	116.52		9+ 738.81	116.42	2		29	98.60	0.662	21.45	114.26	114.15	0.51%	75	1.710	0.39	0.79	0.39	0.31		
	53	Chandelle Pvt		9+ 738.81	116.42		9+ 756.38	116.33	2		31	105.40	0.708	17.57	114.15	114.06	0.52%	75	1.726	0.41	0.81	0.39	0.32		
	54	Chandelle Pvt		9+ 756.38	116.33	SAP 9-G	9+ 793.54	116.14	2		33	112.20	0.753	37.16	114.06	113.89	0.45%	75	1.617	0.47	0.84	0.37	0.31		
	55	Chandelle Pvt	SAP 9-G	9+ 793.54	116.14	EXPANDER	9+ 825.00	115.99	4		37	125.80	0.844	31.46	113.89	113.76	0.41%	75	1.542	0.55	0.89	0.35	0.31		
	56	Chandelle Pvt	EXPANDER	9+ 825.00	115.99	SAP 9-H	9+ 867.13	115.78	3		40	136.00	0.913	42.13	113.76	113.50	0.61%	100	4.042	0.23	0.68	0.51	0.35		
	57	Chandelle Pvt	SAP 9-H	9+ 867.13	115.78		9+ 913.34	115.54	5		45	153.00	1.027	46.21	113.50	113.29	0.46%	100	3.515	0.29	0.73	0.45	0.33		
	58	Chandelle Pvt		9+ 913.34	115.54	SAP 9-I	9+ 952.52	115.35	5		50	170.00	1.141	39.18	113.29	113.02	0.68%	100	4.264	0.27	0.71	0.54	0.39		
	59	Chandelle Pvt	SAP 9-I	9+ 952.52	115.35		9+ 977.62	115.41	3		53	180.20	1.210	25.10	113.02	112.95	0.29%	100	2.767	0.44	0.82	0.35	0.29		
	60	Chandelle Pvt		9+ 977.62	115.41	ELBOW	9+ 996.50	115.47	2		55	187.00	1.255	18.88	112.95	112.71	1.23%	100	5.724	0.22	0.66	0.73	0.48	Ex. SBS main to be cut off and capped	
	61	Chandelle Pvt	ELBOW	9+ 996.50	115.47	ELBOW	10+ 4.19	115.53	0		55	187.00	1.255	7.89	112.71	112.67	0.52%	100	3.741	0.34	0.76	0.48	0.36		
	62	Easement	ELBOW	10+ 4.19		SAP 10-A	10+ 10.80	115.64	1		56	190.40	1.278	6.61	112.67	112.63	0.52%	100	3.741	0.34	0.76	0.48	0.36		
	63	Easement	SAP 10-A	10+ 10.80	115.64		10+ 84.19	115.90	6		62	210.80	1.415	73.39	112.63	112.25	0.52%	100	3.741	0.38	0.78	0.48	0.37		
	64	Easement 2	CAP	401+ 50.00	115.29	SAP 401-B	401+ 51.33	115.20	0		137	444.80	2.986	1.33	111.97	111.96	0.62%	150	12.040	0.25	0.69	0.68	0.47	Add seg.#126 (Phase 1B-2)	
	65	Easement 4	SAP 401-B	401+ 51.33	115.20	WYE-W.	401+ 51.33	115.33	0																
	66	Easement 2	WYE-W.	401+ 57.52	115.33		401+ 65.96	115.00	0		137	635.20	4.264	8.44	111.88	111.83	0.63%	150	12.071	0.35	0.77	0.68	0.53		
	67	Easement 2		401+ 65.96	115.00		401+ 79.58	114.68	0		137	635.20	4.264	13.62	111.83	111.72	0.76%	150	13.245	0.32	0.75	0.75	0.56		
	68	Easement 2		401+ 79.58	114.68		401+ 90.10	114.62	0		137	635.20	4.264	10.53	111.72	111.70	0.24%	150	7.422	0.57	0.91	0.42	0.38		
	69	Easement 2		401+ 90.10	114.62	SAP 401-C	401+ 138.07	114.09	0		137	635.20	4.264	38.66	111.70	111.50	0.50%	150	10.816	0.39	0.80	0.61	0.49		
	70	Easement 2	SAP 401-C	401+ 138.07	114.09		401+ 150.50	114.00	0		137	635.20	4.264	12.43	111.50	111.42	0.70%	150	12.742	0.33	0.76	0.72	0.55		
	71	Easement 2		401+ 150.50	114.00		401+ 163.17	113.84	0		137	635.20	4.264	12.68	111.42	111.37	0.35%	150	8.973	0.48	0.85	0.51	0.43		
	72	Easement 2		401+ 163.17	113.84		401+ 172.52	113.69	0		137	635.20	4.264	9.34	111.37	111.31	0.71%	150	12.800	0.33	0.76	0.72	0.55		
	73	Easement 2		401+ 172.52	113.69		401+ 183.48	113.58	0		137	635.20	4.264	10.97	111.31	111.20	0.97%	150	14.973	0.28	0.73	0.85	0.61		
	74	Easement 2		401+ 183.48	113.58		401+ 190.30	113.52	0		137	635.20	4.264	6.82	111.20	111.17	0.51%	150	10.909	0.39	0.80	0.62	0.50		
	75	Easement 2		401+ 190.30	113.52		401+ 198.85	113.46	0		137	635.20	4.264	8.55	111.17	111.09	0.92%	150	14.637	0.29	0.73	0.83	0.60		
	76	Easement 2		401+ 198.85	113.46		401+ 209.92	113.39	0		137	635.20	4.264	11.06	111.09	111.02	0.57%	150	11.493	0.37	0.78	0.65	0.51		
	77	Easement 2		401+ 209.92	113.39	SAP 401-D	401+ 222.96	113.28	0		137	635.20	4.264	13.04	111.02	110.86	1.28%	150	17.235	0.25	0.69	0.98	0.68		
	78	Easement 2	SAP 401-D	401+ 222.96	113.28		401+ 256.44	112.92	0		137	635.20	4.264	33.49	110.86	110.77	0.27%	150	7.939	0.54	0.88	0.45	0.40		
	79	Easement 2		401+ 256.44	112.92		401+ 285.49	112.82	0		137	635.20	4.264	29.05	110.77	110.62	0.49%	150	10.610	0.40	0.81	0.60	0.48		
	80	Easement 2		401+ 285.49	112.82	SAP 401-E	401+ 305.92	112.73	0		137	635.20	4.264	20.43	110.62	110.55	0.38%	150	9.351	0.46	0.83	0.53	0.44		
	81	Easement 2	SAP 401-E	401+ 305.92	112.73		401+ 325.10	112.65	0		137	635.20	4.264	19.18	110.55	110.42	0.68%	150	12.586	0.34	0.76	0.71	0.54		
	82	Easement 2		401+ 325.10	112.65		401+ 343.20	112.58	0		137	635.20	4.264	18.10	110.42	110.31	0.57%	150	11.544	0.37	0.78	0.65	0.51		
	83	Easement 2		401+ 343.20	112.58		401+ 344.24	112.58	0		137	635.20	4.264	1.04	110.31	110.26	4.63%	150	32.765	0.13	0.57	1.85	1.06		
	84	Easement 2		401+ 344.24	112.58		401+ 353.78	112.53	0		137	635.20	4.264	9.54	110.26	110.21	0.60%	150	11.772	0.36	0.78	0.67	0.52		
	85	Easement 2		401+ 353.78	112.53	BEND	401+ 358.59	112.22	0		137	635.20	4.264	4.81	110.21	110.18	0.50%	150	10.754	0.40	0.80	0.61	0.49		
	86	Easement 2	BEND	401+ 358.59	112.22	To Wingover	401+ 381.96	112.72	0		137	635.20	4.264	3.37	110.18	110.17	0.50%	150	10.817	0.39	0.80	0.61	0.49	To Ex. Phase 1A	

EXISTING PAHSE 1B-1 (Cont'd)

NOTES:

n = Manning's coefficient
q = Average daily per capita flow =

I = Unit average extraneous flow (new) =
M = Peak Factor (Harmon) =

$$M = 1 + \frac{14}{4 + \sqrt{P}}$$

Min. pipe cover =
Pop. Single family home =
Pop. Townhouses =

0.013
290.00 L/cap/d

0.00 L/cap/d
2.00 for SBS
where M_{MAX} = 4.5 for historic
M_{MIN} = 2.0 for historic

2.20 m
3.40 cap/unit
2.70 cap/unit

PROJECT:

West Capital Airpark (Carp Airp
Ottawa, Ontario

PROJECT No.:

06001



300-1545 Carling Ave, Ottawa, ON K1Z 8P9
Tel: (613)599-6474, Fax: (613)599-7478
© Copyright Clearford Water Systems Inc., 2019

DESIGNED BY:

Y. Wang

CHECKED BY:

W. G. Stefan

DATE:

Dec 12th, 2022

REVISED:

Jul. 25th, 2023

Feb 13th, 2024

This document has been prepared by and remains the property of Clearford Industries Inc. It is submitted to the specified user solely for its use in conjunction with the project for which it was prepared and is to be held proprietary to Clearford Industries Inc. The user agrees by the acceptance or use of this document to return it to Clearford Industries Inc. upon request, and not to reproduce, copy, lend, transmit or otherwise disclose or dispose of the contents, directly or indirectly, and not to use it for any purpose other than that for which it has been specifically furnished.

06001-West Capital Airpark (Carp Airpark) Residential Development: Clearford SBS® Sanitary Sewer Design Sheet

Phase	Seq. #	Location							Cumulative					Sewer Parameters				Flow Design				Comments/Areas				
		1	2		3		4	5	6	7	8	9	10	11	12	13	14	15	16	17	18					
		Location	From (Label)	From Chainage	From Proposed Grade	To (Label)	To Chainage	To Proposed Grade	Residential Connections	Equivalent Connections	Cumulative Equivalent Connections	Equivalent Cumulative Pop.	Design Flow, Qp (L/s)	Pipe Length (m)	U/S Invert (m)	D/S Invert (m)	Proposed Sewer Slope (%)	Pipe Size, (mm)	Pipe Capacity Qf (L/s)	Capacity Ratio Qp/Qf	Velocity Ratio Vp/Vf	Full Flow Velocity (m/s)	Peak Design Velocity (m/s)			
EXISTING PHASE 2A	87	Silver Dart Pvt	SAP 3-A	3+	85.00	117.72	EX. CAP	3+	14.15	117.12	8		8	27.20	0.183	70.85	115.45	115.09	0.50%	75	1.703	0.11	0.52	0.39	0.20	Start of run (Phase 2A)
	88	Silver Dart Pvt	EX. CAP	3+	14.15	117.12	EX. WYE	1+	87.60	117.09	0		8	27.20	0.183	11.34	115.09	115.03	0.53%	75	1.745	0.10	0.52	0.39	0.21	
	89	Wingover Pvt	EX.SAP 7-A	6+	-14.20	116.30	EX. WYE	6+	-3.30	116.30	1		1	3.40	0.023	10.00	114.03	113.73	2.93%	75	4.104	0.01	0.00	0.93	0.00	
	90	Silver Dart Pvt	SAP 3-B	3+	90.00	117.77	EXPANDER	3+	396.33	116.07	37		37	125.80	0.844	306.33	115.50	113.77	0.56%	75	1.800	0.47	0.84	0.41	0.34	Start of run (Phase 2A)
	91	Silver Dart Pvt	EXPANDER	3+	396.33	116.07		3+	500.00	116.15	5		42	142.80	0.959	103.67	113.77	113.56	0.20%	100	2.310	0.41	0.81	0.29	0.24	
	92	Fleet Canuck Pvt		4+	18.31	116.15	WYE 4-A	4+	115.75	115.51	7		49	166.60	1.118	97.44	113.56	113.08	0.50%	100	3.639	0.31	0.74	0.46	0.34	
	93	Fleet Canuck Pvt	WYE 4-A	4+	115.75	115.51	BEND	4+	207.90	114.93	17		80	254.50	1.708	92.15	113.08	112.62	0.50%	100	3.639	0.47	0.84	0.46	0.39	Add segment #101
	94	Fleet Canuck Pvt	BEND	4+	207.90	114.93	EXPANDER	4+	208.90	114.92	0		80	254.50	1.708	1.00	112.62	112.62	0.50%	100	3.639	0.47	0.84	0.46	0.39	
	95	Fleet Canuck Pvt	EXPANDER	4+	208.90	114.92	WYE 4-B	4+	212.78	114.89	0		80	261.50	1.708	3.88	112.62	112.60	0.50%	150	10.728	0.16	0.60	0.61	0.37	
	96	Fleet Canuck Pvt	WYE 4-B	4+	212.78	114.89		4+	214.32	114.89	0		93	298.70	2.005	1.54	112.60	112.59	0.50%	150	10.728	0.19	0.63	0.61	0.38	Add segment #103
97	Fleet Canuck Pvt		4+	214.32	114.89	BEND	4+	215.22	114.91	0		93	298.70	2.005	0.90	112.59	112.58	1.21%	150	16.748	0.12	0.54	0.95	0.52		
98	Fleet Canuck Pvt	BEND	4+	215.22	114.91	WYE 4-C	4+	217.40	114.98	0		93	298.70	2.005	2.18	112.58	112.55	1.21%	150	16.748	0.12	0.54	0.95	0.52		
99	Fleet Canuck Pvt	WYE 4-C	4+	217.40	114.98	BEND	4+	261.45	114.37	0		121	377.80	2.536	44.05	112.55	112.02	1.21%	150	16.748	0.15	0.60	0.95	0.57	Add segment #102	
100	Off-road to Wingove	BEND	4+	261.45	114.37	EX. WYE	6+	368.59	114.32	0		121	377.80	2.536	50.00	112.02	111.92	0.20%	150	6.811	0.37	0.78	0.39	0.30	To Ex. Phase 1A	
101	Hawker Pvt	SAP 5-B	5+	99.00	115.74	WYE 4-A	5+	4.00	115.56	14		14	37.80	0.254	95.00	113.47	113.10	0.39%	75	1.488	0.17	0.62	0.34	0.21	Start of run	
102	Hawker Pvt	SAP 5-C	5+	102.05	115.73	WYE 4-C	5+	275.91	114.99	28		28	79.10	0.531	173.86	113.46	112.60	0.49%	75	1.679	0.32	0.75	0.38	0.28	Start of run	
103	Hawker Pvt	SAP 5-G	5+	377.85	115.50	WYE 4-B	5+	277.23	115.00	13		13	44.20	0.297	100.62	113.23	112.65	0.57%	75	1.813	0.16	0.61	0.41	0.25	Start of run	
PROPOSED PHASE 1B-2	104	Street Three	SAP 11-A	11+	16.00	117.79	SAP 11-B	11+	103.14	117.28	16		16	46.00	0.309	87.14	115.51	115.00	0.60%	75	1.851	0.17	0.61	0.42	0.26	Start of run
	105	Street Three	SAP 11-B	11+	103.14	117.28		11+	115.34	117.20	4		20	57.50	0.386	12.20	115.00	114.92	0.60%	75	1.851	0.21	0.65	0.42	0.27	
	106	Street Three		11+	115.34	117.20		11+	133.94	117.29	3		23	66.30	0.445	18.60	114.92	114.84	0.47%	75	1.648	0.27	0.72	0.37	0.27	
	107	Street Three		11+	133.94	117.29		11+	176.16	117.38	8		31	90.00	0.604	42.22	114.84	114.64	0.47%	75	1.648	0.37	0.78	0.37	0.29	
	108	Street Three		11+	176.16	117.38	SAP 11-C	11+	184.90	117.30	3		34	98.80	0.663	8.74	114.64	114.59	0.47%	75	1.648	0.40	0.81	0.37	0.30	
	109	Street Three	SAP 11-C	11+	184.90	117.30	EXPANDER	11+	236.22	116.91	9		43	125.20	0.840	51.32	114.59	114.35	0.47%	75	1.648	0.51	0.87	0.37	0.32	
	110	Street Three	EXPANDER	11+	236.22	116.91		11+	264.66	116.88	0		43	125.20	0.840	28.44	114.35	114.27	0.28%	100	2.740	0.31	0.74	0.35	0.26	
	111	Street Three		11+	264.66	116.88	SAP 11-D	11+	270.88	116.91	1		44	128.60	0.863	6.22	114.27	114.25	0.35%	100	3.038	0.28	0.73	0.39	0.28	
	112	Street Three	SAP 11-D	11+	270.88	116.91		11+	302.18	117.07	4		48	142.20	0.955	31.30	114.25	114.14	0.35%	100	3.041	0.31	0.75	0.39	0.29	
	113	Street Three		11+	302.18	117.07		11+	349.44	116.61	5		53	159.20	1.069	47.26	114.14	113.98	0.35%	100	3.040	0.35	0.77	0.39	0.30	
	114	Street Three		11+	349.44	116.61	SAP 11-E	11+	354.88	116.55	0		53	159.20	1.069	5.44	113.98	113.96	0.35%	100	3.037	0.35	0.77	0.39	0.30	
	115	Street Three	SAP 11-E	11+	354.88	116.55	SAP 11-F	11+	428.60	116.53	11		64	196.60	1.320	73.73	113.96	113.70	0.35%	100	3.041	0.43	0.82	0.39	0.32	
	116	Street Three	SAP 11-F	11+	428.60	116.53	SAP 11-G	11+	506.58	116.11	9		73	227.20	1.525	77.98	113.70	113.43	0.35%	100	3.040	0.50	0.87	0.39	0.34	
	117	Street Three	SAP 11-G	11+	506.58	116.11	BEND (VER)	11+	511.59	116.01	0		73	227.20	1.525	5.01	113.43	113.42	0.35%	100	3.044	0.50	0.87	0.39	0.34	
118	Street Three	BEND (VER)	11+	511.59	116.01	BEND (VER)	11+	521.82	116.01	0		73	227.20	1.525	10.23	113.42	112.41	9.85%	100	16.209	0.09	0.51	2.06	1.05		
119	Street Three	BEND (VER)	11+	521.82	116.01	WYE	11+	530.20	115.89	0		73	227.20	1.525	0.36	112.41	112.33	0.73%	100	4.404	0.35	0.76	0.56	0.43	To Street 10+ (Phase 2D)	
120	Easement	BEND	10+	84.19	115.90	EXPANDER	10+	95.74	115.93	0		62	210.80	1.415	11.55	112.25	112.21	0.30%	100	2.825	0.50	0.87	0.36	0.31	Add seg.#63	
121	Easement	EXPANDER	10+	95.74	115.93	WYE	10+	97.74	115.89	0		62	210.80	1.415	2.00	112.21	112.21	0.30%	150	8.328	0.17	0.61	0.47	0.29		
122	Easement	WYE	10+	97.74	115.89	SAP 10-B	10+	100.00	115.88	0		135	438.00	2.940	2.26	112.21	112.20	0.30%	150	8.328	0.35	0.77	0.47	0.37	Add seg.#119	
123	Easement	SAP 10-B	10+	100.00	115.88	BEND	10+	130.27	115.76	2		137	444.80	2.986	30.27	112.20	112.11	0.30%	150	8.328	0.36	0.77	0.47	0.37		
124	Easement	BEND	10+	130.27	115.76	BEND	10+	134.26	115.81	0		137	444.80	2.986	6.03	112.11	112.09	0.30%	150	8.328	0.36	0.77	0.47	0.37	To Street 401+ (Phase 1B)	
125	Easement 2	BEND	401+	6.24	115.81		401+	10.22	115.71	0		137	444.80	2.986	6.03	112.11	112.09	0.30%	150	8.326	0.36	0.77	0.47	0.37		
126	Easement 2		401+	10.22	115.71	EX. CAP	401+	53.86	115.43	0		137	444.80	2.986	43.64	112.09	111.96	0.30%	150	8.328	0.36	0.77	0.47	0.37	To Ex. Phase 1B	

NOTES:

n = Manning's coefficient
q = Average daily per capita flow =

I = Unit average extraneous flow (new) =
M = Peak Factor (Harmon) =

$$M = 1 + \frac{14}{4 + \sqrt{P}}$$

Min. pipe cover =
Pop. Single family home =
Pop. Townhouses =

0.013
290.00 L/cap/d

0.00 L/cap/d
2.00 for SBS
where M_{MAX} = 4.5 for historic
M_{MIN} = 2.0 for historic

2.20 m
3.40 cap/unit
2.70 cap/unit

PROJECT:

West Capital Airpark (Carp Airp
Ottawa, Ontario

PROJECT No.:
06001



300-1545 Carling Ave, Ottawa, ON K1Z 8P9
Tel: (613)599-6474, Fax: (613)599-7478
© Copyright Clearford Water Systems Inc., 2019

DESIGNED BY:

Y.Wang

CHECKED BY:

W.G.Stefan

DATE:

Dec 12th, 2022

REVISED:

Jul. 25th, 2023
Feb 13th, 2024

This document has been prepared by and remains the property of Clearford Industries Inc. It is submitted to the specified user solely for its use in conjunction with the project for which it was prepared and is to be held proprietary to Clearford Industries Inc. The user agrees by the acceptance or use of this document to return it to Clearford Industries Inc. upon request, and not to reproduce, copy, lend, transmit or otherwise disclose or dispose of the contents, directly or indirectly, and not to use it for any purpose other than that for which it has been specifically furnished.

Appendix F: System Access Points and Collection System Details

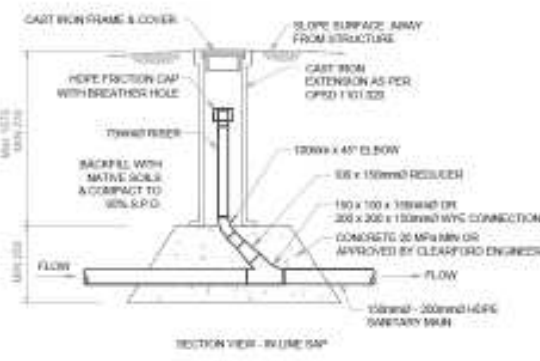
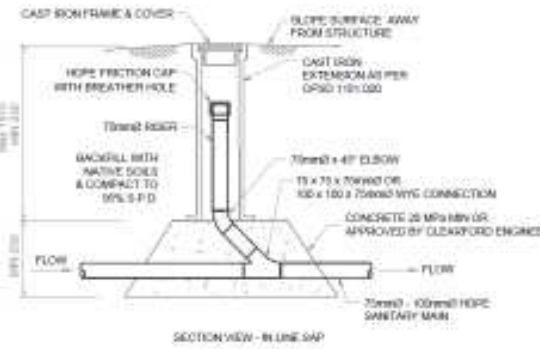
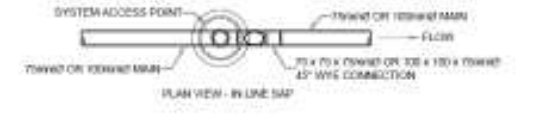
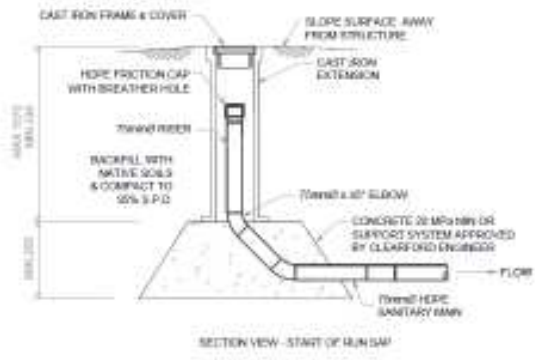
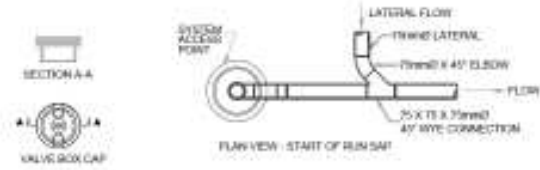

CLEARFORD SYSTEM ACCESS POINT (SAP) DETAILS - LOAD BEARING

NOTES

NO	REVISION	DATE	BY	CHECKED BY	APPROVED BY
1	ISSUED FOR APPROVAL	07/27/18	MS		

DRAWING TITLE	APPENDIX C-1 CLEARFORD SYSTEM ACCESS POINTS
CLIENT	WEST CAPITAL DEVELOPMENTS

CLEARFORD
WATER SYSTEMS INC.

575 Lighthelm Drive, Suite 120
Olathe, Kansas 66061
Tel: 913.880.8172 Fax: 913.880.0178
Toll Free: 1-800-221-1114
www.clearford.com