

1296 & 1400 Old Montreal Road Transportation Impact Assessment

Step 1 Screening Report

Step 2 Scoping Report

Step 3 Forecasting Report

Step 4 Strategy Report (Revision #1)

Prepared for:

Tamarack Corp.
3187 Albion Road South
Ottawa ON K1V 8Y3

Prepared by:



6 Plaza Court
Ottawa, ON K2H 7W1

October 2024

PN: 2019-68

Table of Contents

1	Screening	1
2	Existing and Planned Conditions	1
2.1	Proposed Development.....	1
2.2	Existing Conditions	3
2.2.1	Area Road Network.....	3
2.2.2	Existing Intersections.....	3
2.2.3	Existing Driveways	4
2.2.4	Cycling and Pedestrian Facilities.....	5
2.2.5	Existing Transit.....	7
2.2.6	Existing Area Traffic Management Measures.....	9
2.2.7	Existing Peak Hour Travel Demand.....	9
2.2.8	Collision Analysis.....	10
2.3	Planned Conditions.....	12
2.3.1	Changes to the Area Transportation Network	12
2.3.2	Other Study Area Developments	15
3	Study Area and Time Periods	15
3.1	Study Area	15
3.2	Time Periods	16
3.3	Horizon Years.....	16
4	Exemption Review	16
5	Development-Generated Travel Demand	16
5.1	Mode Shares.....	16
5.2	Trip Generation	17
5.3	Trip Distribution.....	18
5.4	Trip Assignment.....	18
6	Background Network Travel Demands.....	19
6.1	Transportation Network Plans	19
6.2	Background Growth.....	19
6.3	Other Developments	20
7	Demand Rationalization	20
7.1	2027 Future Background Operations	20
7.2	2032 Future Background Operations	22
7.3	Modal Share Sensitivity	23
8	Development Design	24
8.1	Design for Sustainable Modes.....	24
8.2	New Street Networks	24
9	Boundary Street Design.....	25
10	Access Intersections Design	26
10.1	Location and Design of Access.....	26
10.2	Intersection Control.....	26
10.3	Access Intersection Design	26
10.3.1	2027 Future Total Access Intersection Operations	26

10.3.2	2032 Future Total Access Intersection Operations	27
10.3.3	Access Intersection MMLOS.....	28
10.3.4	Recommended Design Elements.....	28
11	Transportation Demand Management	28
11.1	Context for TDM	28
11.2	Need and Opportunity.....	28
11.3	TDM Program	29
12	Neighbourhood Traffic Management.....	29
13	Transit.....	29
13.1	Route Capacity.....	29
13.2	Transit Priority	29
14	Network Concept.....	30
15	Network Intersection Design.....	30
15.1	Network Intersection Control.....	30
15.2	Network Intersection Design.....	30
15.2.1	2027 Future Total Network Intersection Operations.....	30
15.2.2	2032 Future Total Network Intersection Operations.....	31
15.2.3	Network Intersection MMLOS.....	32
15.2.4	Recommended Design Elements.....	32
16	Summary of Improvements Indicated and Modifications Options.....	32
17	Conclusion	35

List of Figures

Figure 1: Area Context Plan	1
Figure 2: Concept Plan.....	2
Figure 3: Existing Driveways	5
Figure 4: Study Area Pedestrian Facilities	6
Figure 5: Study Area Cycling Facilities	6
Figure 6: Existing Pedestrian Volumes	7
Figure 7: Existing Cyclist Volumes	7
Figure 8: Existing Study Area Transit Service.....	8
Figure 9: Existing Study Area Transit Stops	8
Figure 10: Existing Traffic Counts	9
Figure 11: Study Area Collision Records – Representation of 2015-2019.....	11
Figure 12: New Ways to Bus Service Map	13
Figure 13: Pathway System	14
Figure 14: Land Use Plan	14
Figure 15: New Site Generation Auto Volumes.....	19
Figure 16: 2027 & 2032 Traffic Re-Assignment.....	20
Figure 17: 2027 Future Background Volumes	21
Figure 18: 2032 Future Background Volumes	22
Figure 19: Concept Pedestrian and Cycling Network	24
Figure 20: Concept Traffic Calming Plan.....	25

Figure 21: 2027 Future Total Volumes 26
 Figure 22: 2032 Future Total Volumes 27

Table of Tables

Table 1: Intersection Count Date..... 9
 Table 2: Existing Intersection Operations..... 9
 Table 3: Study Area Collision Summary, 2015-2019 10
 Table 4: Summary of Collision Locations, 2015-2019 11
 Table 5: Old Montreal Road between Grand Chene Cour Du Court and Ted Kelly Lane Collision Summary 12
 Table 6: Exemption Review 16
 Table 7: TRANS Trip Generation Manual Recommended Mode Shares – Orleans..... 16
 Table 8: Trip Generation Person Trip Rates by Peak Period..... 17
 Table 9: Total Residential Person Trip Generation by Peak Period..... 17
 Table 10: Residential Trip Generation by Mode..... 17
 Table 11: OD Survey Distribution – Orleans 18
 Table 12: Trip Assignment 18
 Table 13: TRANS Regional Model Projections – Study Area Growth Rates..... 19
 Table 14: 2027 Future Background Intersection Operations 21
 Table 15: 2032 Future Background Intersection Operations 22
 Table 16: Boundary Street MMLOS Analysis 25
 Table 17: 2027 Future Total Access Intersection Operations 27
 Table 18: 2032 Future Total Access Intersection Operations 28
 Table 19: Trip Generation by Transit Mode 29
 Table 20: 2027 Future Total Network Intersection Operations 30
 Table 21: 2032 Future Total Network Intersection Operations 31

List of Appendices

Appendix A – TIA Screening Form and Certification Form
 Appendix B – TIA First Submission Comments
 Appendix C – Turning Movement Count Data
 Appendix D – Synchro and Sidra Intersection Worksheets – Existing Conditions
 Appendix E – Collision Data
 Appendix F – TRANS Model Plots
 Appendix G – Synchro Intersection Worksheets – 2027 Future Background Conditions
 Appendix H – Synchro Intersection Worksheets – 2032 Future Background Conditions
 Appendix I – MMLOS Analysis
 Appendix J – Signal Warrants
 Appendix K – Synchro Intersection Worksheets – 2027 Future Total Conditions
 Appendix L – Synchro Intersection Worksheets – 2032 Future Total Conditions
 Appendix M – TDM Checklist

1 Screening

This study has been prepared according to the City of Ottawa’s 2017 Transportation Impact Assessment (TIA) Guidelines, prior to the June 2023 updates. Accordingly, a Step 1 Screening Form has been prepared and is included as Appendix A, along with the Certification Form for TIA Study PM. As shown in the Screening Form, a TIA is required including the Design Review component and the Network Impact Component. A TIA supporting a zoning and plan of subdivision application was prepared in December of 2021. City comments were provided in June of 2023 the transportation component of which are excerpted in Appendix B, and the TIA has been revised to address these comments for the zoning and plan of subdivision application.

2 Existing and Planned Conditions

2.1 Proposed Development

The proposed development, located at 1296 & 1400 Old Montreal Road, is currently a greenfield property and zoned primarily as Rural Countryside Zone (RU), with areas designated as Arterial Mainstreet Zone (AM), Rural Institutional Zone (RI) and Parks and Open Space Zone (O). The proposed development includes 446 townhome units, and 377 single detached units. The proposed access will be through two new collector roads access on Old Montreal Road and Cox Country Road. The anticipated full build-out and occupancy horizon is 2027 with construction occurring in five phases. The site is located within the Cardinal Creek Village Community Design Plans and intersects the Old Montreal Arterial Mainstreet design priority area. Figure 1 illustrates the Study Area Context. Figure 2 illustrates the proposed concept plan.

Figure 1: Area Context Plan

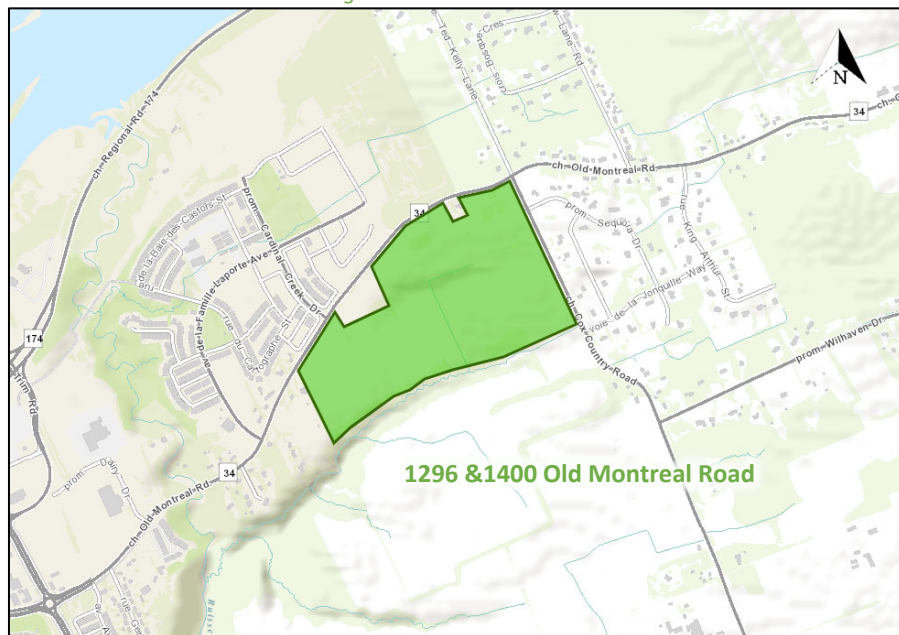

Source: <http://maps.ottawa.ca/geoOttawa/> Accessed: November 11, 2021

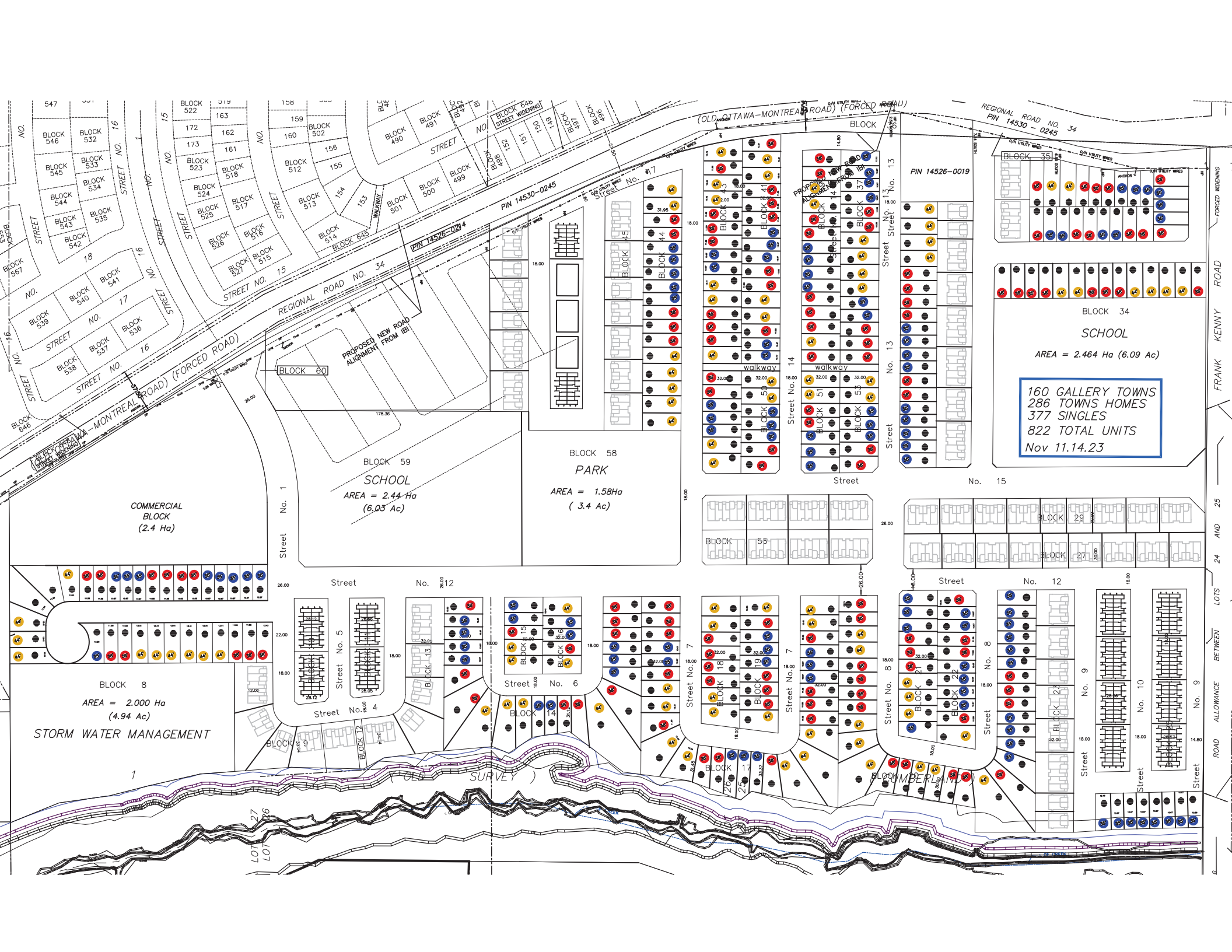

2.2 Existing Conditions

2.2.1 Area Road Network

Old Montreal Road: Old Montreal Road is a City of Ottawa arterial road with paved shoulders. The roadway is two-lane urban cross-section east of Dairy Drive/ Aveia Private and rural cross-section to the west. The posted limit is 60 km/h west of Cardinal Creek Drive and 80 km/h east of Cardinal Creek Drive. The typical City-protected right-of-way is 37.5 metres through the study area, and the right-of-way is widened to 42.5 metres for 65 metres on either side of the Famille-Laporte intersection, including an unequal widening skewed to the south side with 75 metre tapers on the south side between the rights-of-way. Old Montreal Road is a truck route.

St Joseph Boulevard: St Joseph Boulevard is a City of Ottawa arterial road with a four-lane urban cross-section including curbside bike lanes on both sides of the road within the study area. Sidewalks are provided on both sides. The posted limit is 60 km/h and the City-protected right-of-way is 37.5 metres within the study area. St Joseph Boulevard is a truck route.

Trim Road: Trim Road is a City of Ottawa arterial road with a four-lane urban cross-section including curbside bike lanes and Multi-Use Pathways on both sides of the road within the study area. The posted speed limit is 70 km/h posted speed limit and the City-protected right-of-way is 46.0 metre right of way within the study area. Trim Road is a truck route.

Cardinal Creek Drive: Cardinal Creek Drive is a City of Ottawa major collector road with a two-lane cross-section. The posted speed limit is 40 km/h, and the existing right-of-way is 26.0 metres.

Cox Country Road: Cox Country Road is a City of Ottawa collector road with a two-lane cross-section including paved shoulders on both sides of the road and an 80 km/h posted speed limit along the eastern boundary of the site, and the existing right-of-way is 20.0 metres.

Wilhaven Drive: Wilhaven Drive is a City of Ottawa collector road with a two-lane cross-section including paved shoulders. The posted speed limit of 60 km/h, and the existing right-of-way is 20.0 metres.

Famille-Laporte Avenue: Famille-Laporte Avenue is a City of Ottawa collector road with a two-lane cross-section. The unposted speed limit is assumed to be 50 km/h, and the existing right-of-way is 24.0 metres.

Aveia Private: Aveia Private is a City of Ottawa local road with a two-lane cross-section. The unposted speed limit is assumed to be 50 km/h, and the existing right-of-way is 6.0 metres.

Dairy Drive: Dairy Drive is a City of Ottawa local road with a two-lane urban cross-section including paved shoulders and the unposted speed limit is assumed to be 50 km/h. The City-protected right-of-way is 20.0 metres.

Ted Kelly Lane: Ted Kelly Lane is a City of Ottawa local road with a two-lane urban cross-section including paved shoulders and the posted speed limit is 50 km/h. The existing right-of-way is 19.5 metres

2.2.2 Existing Intersections

The existing intersections within one kilometre of the site have been summarized below:

<i>Trim Road & Old Montreal Road/St Joseph Boulevard</i>	The intersection of Trim Road and Old Montreal Road is a four-legged roundabout intersection. Pedestrian crossovers are implemented at all approaches. The northbound and southbound approaches each consist of a shared through/left-turn lane and a shared through/right-turn lane. The eastbound and westbound approaches each consist of
--	--

a shared left-turn/through lane, a through lane, and an auxiliary right-turn bypass lane.

- Aveia Private/Dairy Drive & Old Montreal Road* The intersection of Aveia Private/Dairy Drive and Old Montreal Road is an unsignalized intersection with two-way stop control on Aveia Private/Dairy Drive. The northbound approach consists of an all-movements lane. The southbound, eastbound, and westbound approaches each consist of an auxiliary left-turn lane and a shared through/right-turn lane. Bike lanes are provided on the eastbound and westbound approaches. No turn restrictions are noted.
- Famille-Laporte Avenue & Old Montreal Road* The intersection of Famille-Laporte Avenue & Old Montreal Road is an unsignalized T-intersection with stop-control on Famille-Laporte Avenue. The eastbound approach consists of an auxiliary left-turn lane and through lane, the westbound approach consists of a shared through/right-turn lane, and the southbound approach consists of a shared left-turn/right-turn lane. No turn restrictions are noted.
- Cardinal Creek Drive & Old Montreal Road* The intersection of Cardinal Creek Drive and Old Montreal Road is an unsignalized T-intersection with stop-control on Cardinal Creek Drive. The eastbound approach consists of a shared left-turn/through lane, the westbound approach consists of a shared through/right-turn lane and the southbound approach consists of a shared left-turn/right-turn lane. No turn restrictions are noted.
- Ted Kelly Lane/ Cox Country Road & Old Montreal Road* The intersection of Ted Kelly Lane / Country Road and Old Montreal Road is an unsignalized intersection with two-way stop-control on Cox Country Road. All approaches each consist of an all-movements lane. No turn restrictions are noted.
- Cox Country Road & Wilhaven Drive* The intersection of Cox Country Road and Wilhaven Drive is an unsignalized T-intersection with stop-control on Wilhaven Drive. The westbound approach consists of a shared left-turn/right-turn lane, the northbound approach consists of a shared through/right-turn lane, and the southbound approach consists of a shared left-turn/through lane. No turn restrictions are noted.

2.2.3 Existing Driveways

Within 200 metres of the proposed site accesses, two existing driveways to private residences on Old Montreal Road, there access on Cox Country Road, south of Jonquille Way. Also, one existing farm field access is provided along Old Montreal Road and four existing farm field accesses are provided along Cox Country Road.

None of the driveways would provide access to significant traffic generators and would therefore have no impact on this TIA. Figure 3 illustrates the existing driveways.

Figure 3: Existing Driveways

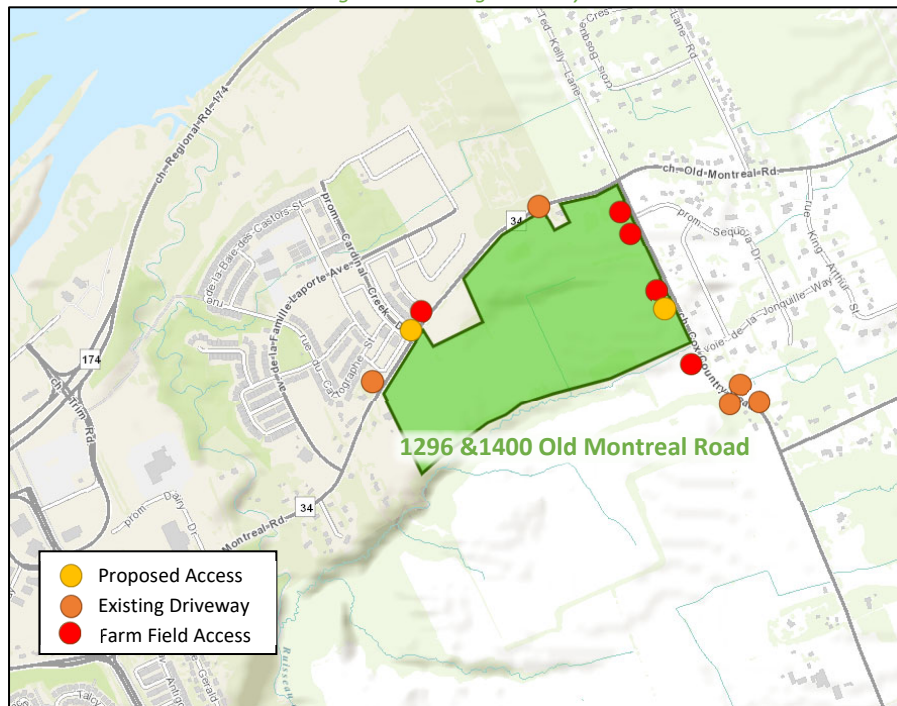

Source: <http://maps.ottawa.ca/geoOttawa/> Accessed: November 11, 2021

2.2.4 Cycling and Pedestrian Facilities

Figure 4 illustrates the pedestrian facilities in the study area and Figure 5 illustrates the cycling facilities.

A sidewalk and multi-use pathway are provided along the north and south sides of Old Montreal Road, respectively, between Trim Road and Aveia Private/Dairy Drive. There are no additional existing pedestrian facilities within the study area.

Cycling facilities include paved shoulders along Cox Country Road and Old Montreal Road between Dairy Drive/Aveia Private and Cox Country Road. A bike lane is provided east of Dairy along Old Montreal Road. Within the 2013 Transportation Master Plan, the Old Montreal Road and Cox Country Road are both designated as spine routes, and Wilhaven Drive is a local route.

Figure 4: Study Area Pedestrian Facilities

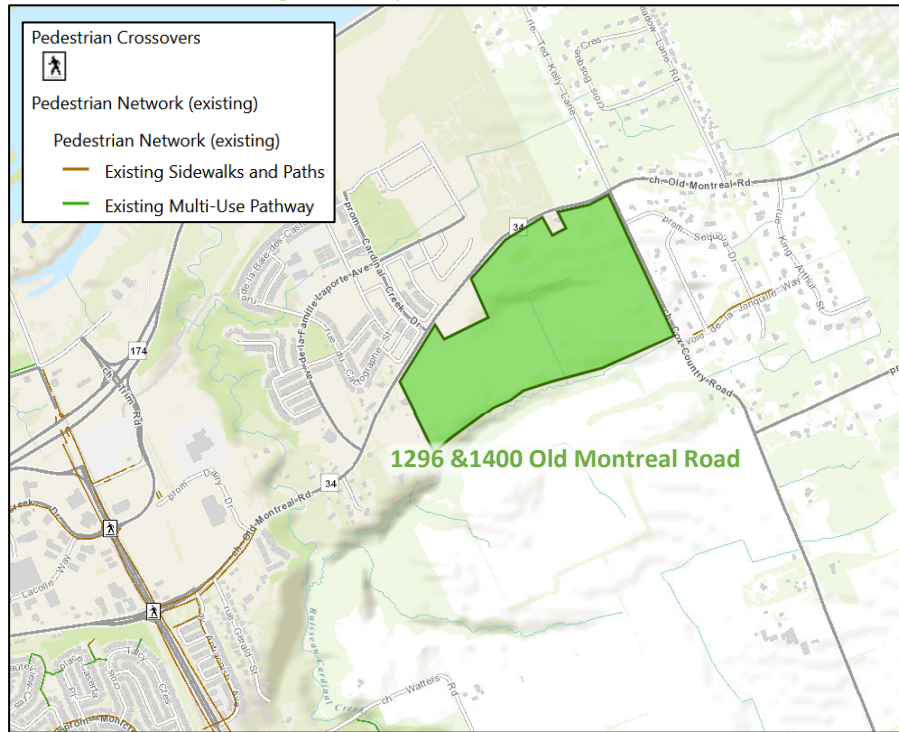

Source: <http://maps.ottawa.ca/geoOttawa/> Accessed: November 11, 2021

Figure 5: Study Area Cycling Facilities

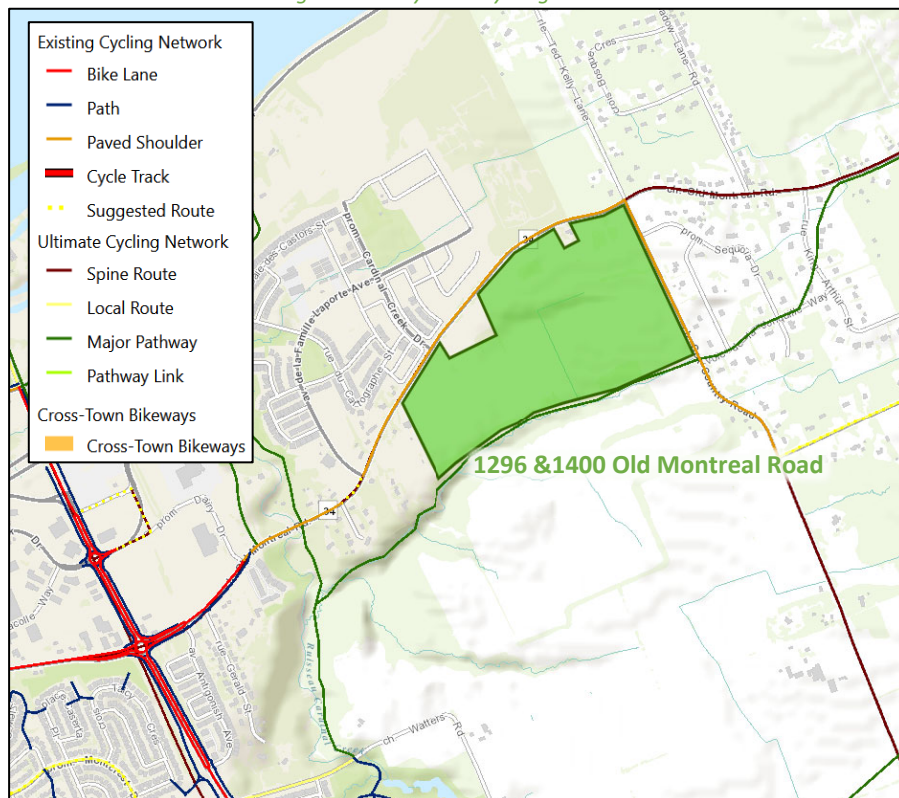

Source: <http://maps.ottawa.ca/geoOttawa/> Accessed: November 11, 2021

Pedestrian and cyclist volumes included in study area intersection counts, presented in Section 2.2.7, have been compiled and are illustrated in Figure 6 and Figure 7 respectively. Only the intersections of Ted Kelly Lane/Cox Country Road at Old Montreal Road, Trim Road at Old Montreal Road/St. Joseph Boulevard, Cox Country Road at Wilhaven Drive, and Aveia Private/Dairy Drive at Old Montreal Road had pedestrian and cyclist volumes available.

Figure 6: Existing Pedestrian Volumes

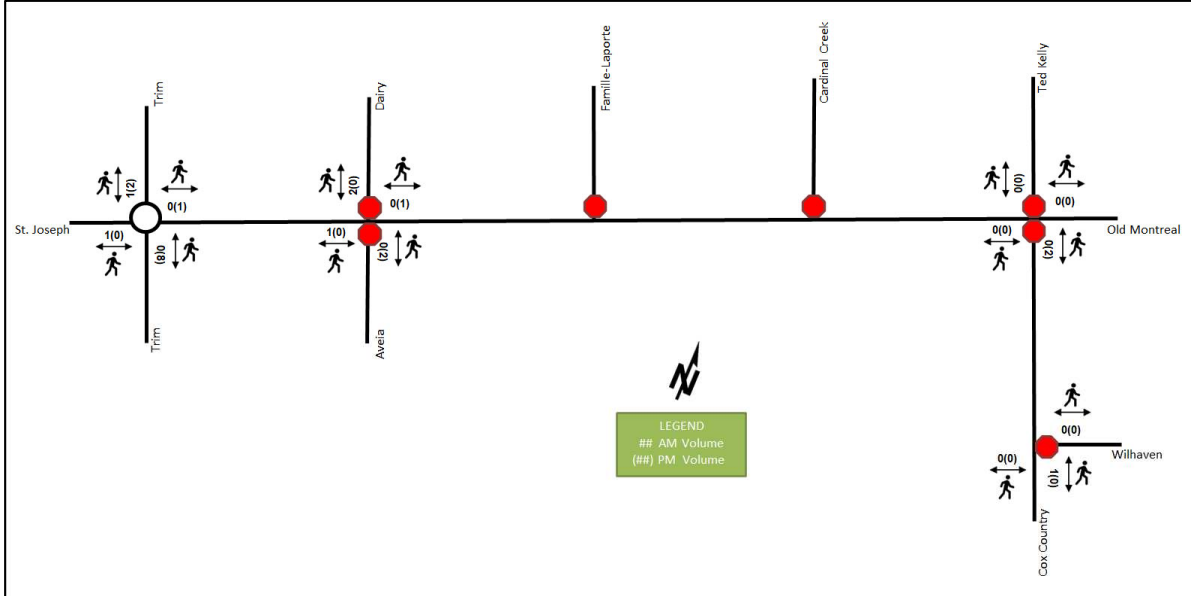
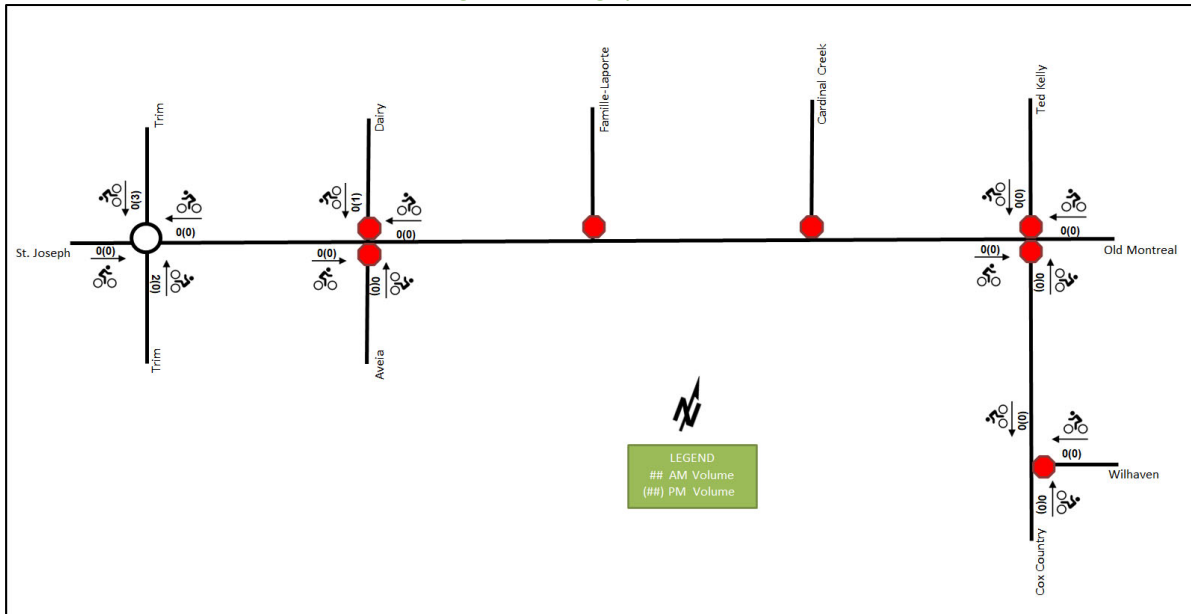

Figure 7: Existing Cyclist Volumes



2.2.5 Existing Transit

Within the study area, route #221 travels along Old Montreal Road and Cox Country Road. The frequency of this route within proximity of the proposed site currently is two AM buses to Blair and two PM return buses.

Figure 8 illustrates the transit system map in the study area and Figure 9 illustrates nearby transit stops.

Figure 8: Existing Study Area Transit Service

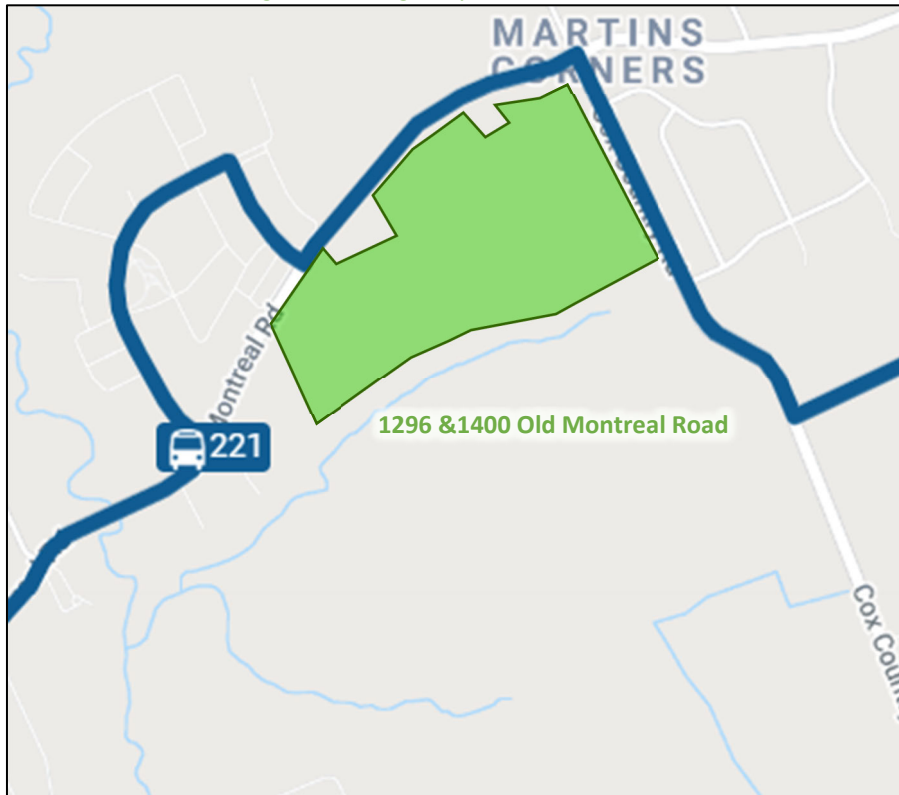

Source: <http://www.octranspo.com/> Accessed: November 11, 2021

Figure 9: Existing Study Area Transit Stops

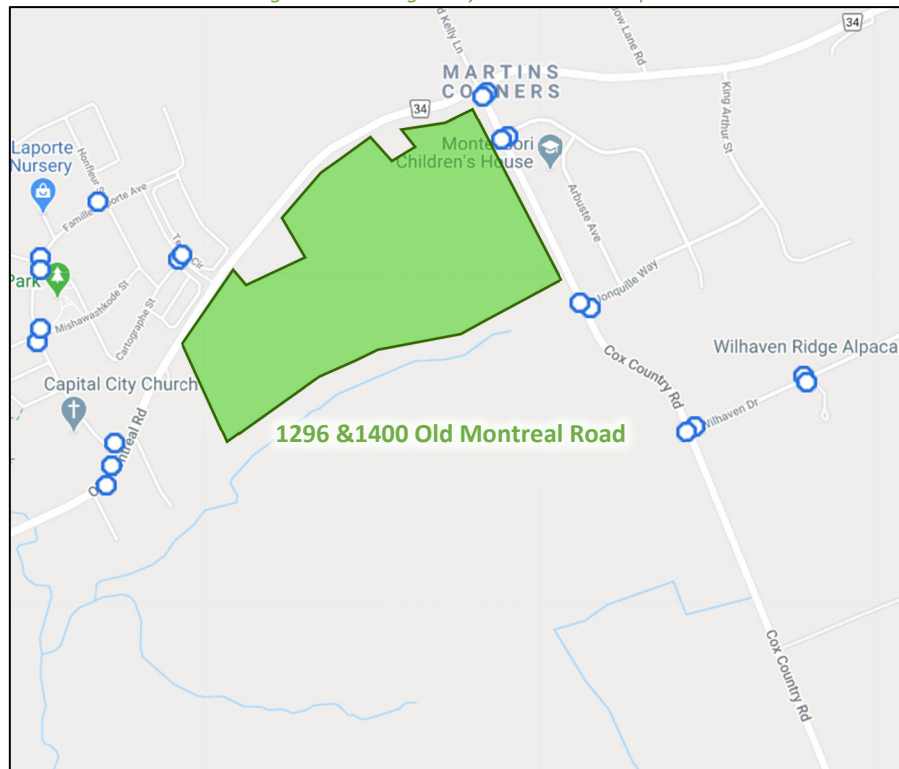

Source: <http://www.octranspo.com/> Accessed: November 11, 2021

2.2.6 Existing Area Traffic Management Measures

There are no existing area traffic management measures within the Study Area.

2.2.7 Existing Peak Hour Travel Demand

Existing turning movement counts were acquired from the City of Ottawa for existing Study Area intersections. Table 1 summarizes the intersection count dates.

Table 1: Intersection Count Date

Intersection	Count Date	Sources
Trim Road & Old Montreal Road/ St. Joseph Boulevard	Wednesday, April 26, 2017	City of Ottawa
Aveia Private/Dairy Drive & Old Montreal Road	Wednesday, December 04, 2019	City of Ottawa
Cardinal Creek Drive & Old Montreal Road	Monday, 11 February 2019	The Traffic Specialist
Ted Kelly Lane/ Cox Country Road & Old Montreal Road	Wednesday, August 28, 2019	City of Ottawa
Cox Country Road & Wilhaven Drive	Wednesday, November 13, 2013	City of Ottawa

Figure 10 illustrates the existing traffic counts and Table 2 summarizes the existing intersection operations. Synchro 11 has been used to model the unsignalized intersections and Sidra 9 to model the study area roundabout. HCM 2010 methodology was used for unsignalized intersection operations and Sidra methodology was used for roundabout intersection operations. Detailed turning movement count data is included in Appendix C and the Synchro and Sidra worksheets are provided in Appendix D.

Figure 10: Existing Traffic Counts

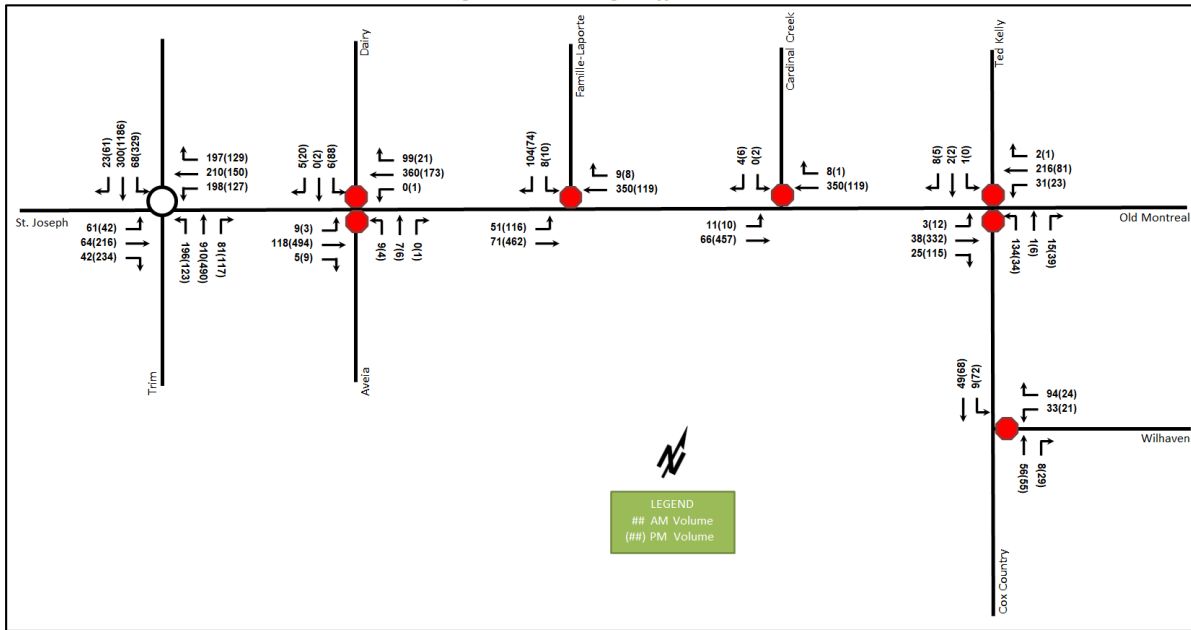

Table 2: Existing Intersection Operations

Intersection	Lane	AM Peak Hour				PM Peak Hour			
		LOS	V/C	Delay	Q (95 th)	LOS	V/C	Delay	Q (95 th)
Trim Road & Old Montreal Road/St. Joseph Boulevard Roundabout	EB	A	0.07	6.9	2.0	A	0.31	8.1	14.6
	WB	A	0.30	8.0	10.2	A	0.15	6.7	4.8
	NB	A	0.50	5.3	19.0	A	0.40	6.4	14.4
	SB	A	0.23	6.8	8.3	B	0.81	10.8	71.1
	Overall	A	0.50	6.3	19.0	A	0.81	8.8	71.1

Intersection	Lane	AM Peak Hour				PM Peak Hour			
		LOS	V/C	Delay	Q (95 th)	LOS	V/C	Delay	Q (95 th)
Aveia Private/Dairy Drive & Old Montreal Road Unsignalized	EBL	A	0.01	8.4	0.0	A	0.00	8.0	0.0
	EBT/R	-	-	-	-	-	-	-	-
	WBL	A	-	0.0	0.0	A	0.00	8.6	0.0
	WBT/R	-	-	-	-	-	-	-	-
	NB	B	0.05	14.8	0.8	C	0.04	16.4	0.8
	SBL	B	0.02	14.8	0.8	C	0.32	22.0	9.8
	SBT/R	B	0.01	11.0	0.0	B	0.03	10.2	0.8
Overall	A	-	0.7	-	-	A	-	2.8	-
Famille-Laporte Avenue & Old Montreal Road Unsignalized	EBL	A	0.05	8.4	1.5	A	0.09	7.8	2.3
	EBT	-	-	-	-	-	-	-	-
	WB	-	-	-	-	-	-	-	-
	SB	B	0.20	12.2	5.3	B	0.13	10.8	3.0
	Overall	A	-	3.0	-	-	A	-	2.3
Cardinal Creek Drive & Old Montreal Road Unsignalized	EB	A	0.01	8.5	0.0	A	0.01	7.6	0.0
	WB	-	-	-	-	-	-	-	-
	SB	B	0.01	12.0	0.0	B	0.01	10.7	0.0
	Overall	A	-	0.3	-	-	A	-	0.3
Ted Kelly Lane/ Cox Country Road & Old Montreal Road Unsignalized	EB	A	0.00	7.7	0.0	A	0.01	7.4	0.0
	WB	A	0.02	7.4	0.8	A	0.02	8.5	0.8
	NB	B	0.28	13.6	9.0	B	0.18	14.2	5.3
	SB	B	0.02	10.2	0.8	B	0.01	10.5	0.0
	Overall	A	-	5.0	-	-	A	-	2.3
Cox Country Road & Wilhaven Drive Unsignalized	WB	A	0.15	9.5	3.8	A	0.06	9.9	1.5
	NB	-	-	-	-	-	-	-	-
	SBL	A	0.01	7.4	0.0	A	0.05	7.5	1.5
	Overall	A	-	5.1	-	-	A	-	3.7

Notes: Saturation flow rate of 1800 veh/h/lane
 Peak Hour Factor = 0.90
 Queue is measured in metres

m = metered queue
 # = volume for the 95th %ile cycle exceeds capacity

During both the AM and PM peak hours, the study area intersection operates well. No capacity issues are noted.

2.2.8 Collision Analysis

Collision data have been acquired from the City of Ottawa open data website (data.ottawa.ca) for five years prior to the commencement of this TIA for the surrounding study area road network. Table 3 summarizes the collisions types and conditions in the study area, Figure 11 illustrates the intersections and segments analyzed, and Table 4 summarizes the total collisions for each of these locations. Collision data are included in Appendix E.

Table 3: Study Area Collision Summary, 2015-2019

		Number	%
Total Collisions		24	100%
Classification	Fatality	0	0%
	Non-Fatal Injury	10	42%
	Property Damage Only	14	58%
Initial Impact Type	Angled	2	8%
	Approaching	5	21%
	Rear end	2	8%
	Sideswipe	1	4%
	SMV Other	13	54%
	Other	1	4%

		Number	%
Total Collisions		24	100%
Road Surface Condition	Dry	13	54%
	Wet	3	13%
	Loose Snow	3	13%
	Slush	1	4%
	Packed Snow	1	4%
	Ice	3	13%
Pedestrian Involved		0	0%
Cyclists Involved		1	4%

Figure 11: Study Area Collision Records – Representation of 2015-2019



Table 4: Summary of Collision Locations, 2015-2019

Intersections / Segments	Number	%
Aveia Priv/ Dairy Dr at Old Montreal Rd	4	17%
Frank Kenny Rd Btwn Jonquille Way and Wilhaven	6	25%
Frank Kenny Rd /Ted Kelly Ln at Old Montreal Rd	2	8%
Old Montreal Rd Btwn Continuation of Old Montreal Rd and Grand-Ch-Ne, CO	1	4%
Old Montreal Rd Btwn Grand-Ch-Ne, Cour Du Crt & Ted Kelly Ln	7	29%
De La Famille-Laporte Ave @ Old Montreal Rd	2	8%
Old Montreal Rd Btwn Gerald Street & Continuation of Old Montreal Rd	1	4%
Antigonish Ave at Old Montreal Rd	1	4%

Within the study area, the segment of Old Montreal Road between Grand Chene Cour Du Court and Ted Kelly Lane is noted to have experienced slightly higher collisions than other intersections. Table 5 summarizes the collision types and conditions for the Old Montreal Road segments between Grand Chene Cour Du Court and Ted Kelly Lane.

Table 5: Old Montreal Road between Grand Chene Cour Du Court and Ted Kelly Lane Collision Summary

		Number	%
Total Collisions		7	100%
Classification	Fatality	0	0%
	Non-Fatal Injury	2	29%
	Property Damage Only	5	71%
Initial Impact Type	Approaching	1	14%
	SMV Other	6	86%
Road Surface Condition	Dry	2	29%
	Wet	1	14%
	Loose Snow	2	29%
	Slush	1	14%
Pedestrian Involved		0	0%
Cyclists Involved		0	0%

The segment of Old Montreal Road between Grand Chene Cour Du Court and Ted Kelly Lane had a total of seven collisions during the 2015-2019 time period, with five involving property damage only and the remaining two having non-fatal injuries. The collision types are most represented by SMV other with six collisions followed by one approaching collision. Weather conditions do not affect collisions at this location.

2.3 Planned Conditions

2.3.1 Changes to the Area Transportation Network

2.3.1.1 Transportation Master Plan 2013

Within the 2013 TMP, the Road Network Concept shows the segment of Old Montreal Road between Trim Road and Cox Country Road as a widened arterial, however, it is not included in the Affordable Network. The Old Montreal Road is planned to be widened beyond the horizons considered within this TIA and include the addition of bus lanes in either direction, sidewalks and cycletracks within a 37.5 metre right-of-way. No environmental assessment or design has been completed for this corridor.

The 2013 TMP also notes a future conceptual bus rapid transit corridor along Old Montreal Road within the Transit Network Concept.

2.3.1.2 Transportation Master Plan – Part 1

The City of Ottawa's Transportation Master Plan – Part 1 recommends active transportation projects up to the year 2046. Paved shoulders are proposed along Old Montreal Road east of Cox Country Road. Trim Road and St-Joseph Boulevard are crosstown bikeways.

2.3.1.3 Transportation Master Plan – Part 2

The City of Ottawa's Transportation Master Plan – Part 2 will recommend road and transit projects up to the year 2046 and is currently in the consultation phase. No recommendations, planned projects, or timing of previously planned projects is currently available as part of this forthcoming document.

2.3.1.4 OC Transpo's New Ways to Bus

Responding to recent ridership trends and anticipating the upcoming completion of the Stage 2 expansion of LRT service within the City, the OC Transpo bus service is planned to be recalibrated to focus on frequency, local service in neighbourhoods, and connections to key destinations. These changes are expected in 2025, and the new service map is illustrated in Figure 12. The development area is noted to be to the east of the extents of this map.

Figure 12: New Ways to Bus Service Map

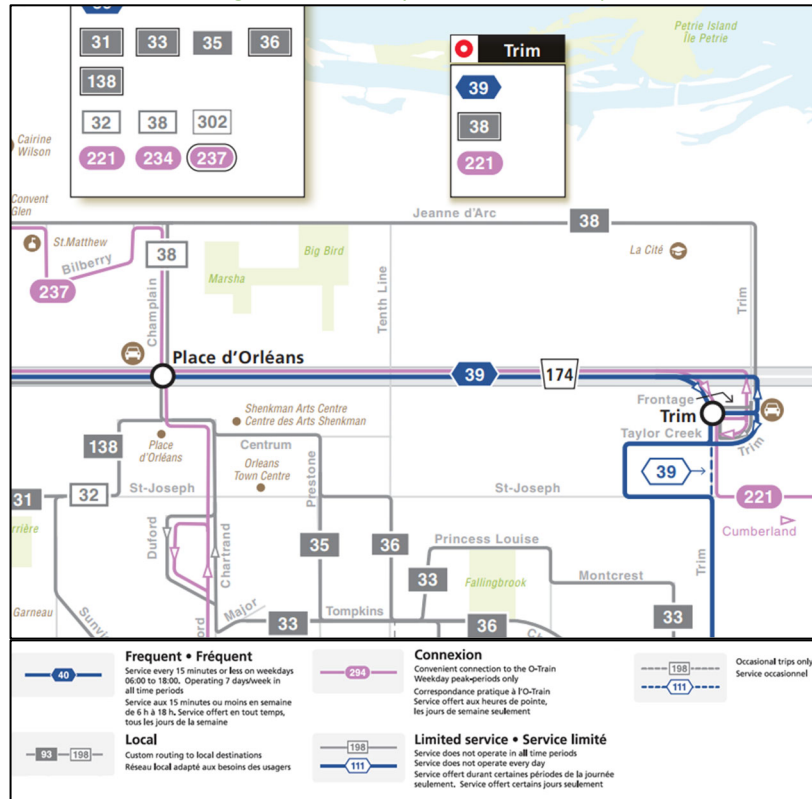

Source: <https://www.octranspo.com/> Accessed: October 22, 2024

2.3.1.5 Stage 2 LRT

The realignment of Trim Road has been completed at OR 174 as part of the Stage 2 LRT O-Train East Extension project. The roadway has been realigned to the east at the previous Dairy Drive Roundabout and Dairy Drive now ends in a cul-de-sac on the south side of Trim Road.

2.3.1.6 Community Design Plan

The Cardinal Creek Village Concept Plan is proposed to include multi-use pathways, cycling facilities and sidewalks that will facilitate pedestrian movement throughout the Cardinal Creek Village Community, and provide connections to adjacent communities. The Cardinal Creek Village Plan is also planned to include major collector roads, minor collector roads, and local roads, which will be consistent with the City of Ottawa Road Corridor Planning and Design Guidelines. Figure 13 illustrates the pathway system, and Figure 14 illustrates the land use plan.

Figure 13: Pathway System



Source: <https://ottawa.ca/en/cardinal-creek-village-concept-plan> Accessed: October 25, 2021

Figure 14: Land Use Plan

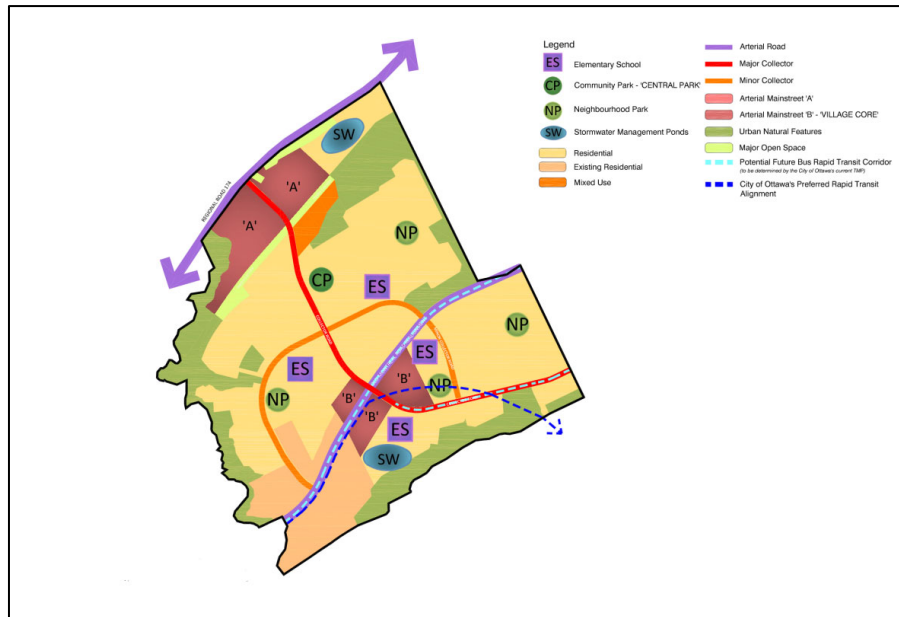

Source: <https://ottawa.ca/en/cardinal-creek-village-concept-plan> Accessed: October 25, 2021

2.3.1.7 Other Changes Within the Study Area

A monitoring exercise is ongoing from the conditions of the Cardinal Creek Village Phase 4 (northwest of Old Montreal Road) development application for the warrant of a (north)eastbound left-turn lane at the intersection of Old Montreal Road at Cardinal Creek Drive. At the time of this report, it is understood that the traffic volumes

meet warrants for this turn lane and that a Roadway Modification Approval is to be pursued. The works associated with this DC project are anticipated to include:

- an eastbound left-turn lane,
- the provision of pavement for the opposing westbound left-turn lane geometry for lane alignment,
- the provision of the pavement for an eastbound right-turn lane supporting the future addition of a south leg to the intersection,
- the widening of the paved shoulder throughout the area of modifications, and
- the signal plant for future signal infrastructure.

2.3.2 Other Study Area Developments

1154, 1172, 1176, 1180, and 1208 Old Montreal Road

The proposed development application includes a plan of subdivision approval and a related zoning by-law amendment application to create and permit the development of 18 blocks and 2 public streets to accommodate a total of 380 residential apartments and 112 low-density units and a park block. The development is forecasted to generate 217 two-way vehicle trips during the AM peak and 270 two-way vehicle trips during the PM peak. (IBI Group, 2021)

1508 Cox Country Road

This application includes a zoning by-law amendment to rezone the subject lands from Agriculture to Rural Countryside. No TIA is available as part of this application.

1730 Wilhaven Drive

The proposed development includes a plan of subdivision application to include a 21 lot rural estate subdivision for the development of single detached dwellings on private services. No TIA is available as part of this application.

1015 Dairy Drive

The proposed development application includes a plan of site plan application to include one building with a gross floor area of 112,000 ft². Phases 1 and 2 are expected to be completed by 2015, and Phases 3 to 7 by 2021. The development is forecasted to generate 67 two-way vehicle trips during the AM peak and 67 two-way vehicle trips during the PM peak. (D. J. Halpenny & Associates Ltd., 2013)

3 Study Area and Time Periods

3.1 Study Area

The study area will include the intersections of:

- Old Montreal Road at:
 - Trim Road Cox
 - Aveia Private/Dairy Drive
 - Famille-Laporte Avenue
 - Cardinal Creek Drive
 - Country Road/Ted Kelly Lane
- Cox Country Road at:
 - Wilhaven Drive

The boundary roads will be Old Montreal Road and Cox Country Road and screenline SL46 is located along the Cox Country Road.

3.2 Time Periods

As the proposed development is composed primarily of residential units the weekday AM and PM peak hours will be examined.

3.3 Horizon Years

The anticipated build-out year is 2027. As a result, the full build-out plus five years horizon year is 2032.

4 Exemption Review

Table 6 summarizes the exemptions for this TIA.

Table 6: Exemption Review

Module	Element	Explanation	Exempt/Required
Design Review Component			
4.1 Development Design	4.1.2 Circulation and Access	Only required for site plans	Exempt
	4.2.3 New Street Networks	Only required for plans of subdivision	Required
4.2 Parking	4.2.1 Parking Supply	Only required for site plans	Exempt
	4.2.2 Spillover Parking	Only required for site plans where parking supply is 15% below unconstrained demand	Exempt
Network Impact Component			
4.5 Transportation Demand Management	All Elements	Not required for site plans expected to have fewer than 60 employees and/or students on location at any given time	Required
4.6 Neighbourhood Traffic Management	4.6.1 Adjacent Neighbourhoods	Only required when the development relies on local or collector streets for access and total volumes exceed ATM capacity thresholds	Required
4.8 Network Concept		Only required when proposed development generates more than 200 person-trips during the peak hour in excess of equivalent volume permitted by established zoning	Required

5 Development-Generated Travel Demand

5.1 Mode Shares

Examining the mode shares recommended in the TRANS Trip Generation Manual (2020) for the subject district, derived from the most recent National Capital Region Origin-Destination survey (OD Survey), the existing average district mode shares by land use for Orleans have been summarized in Table 7.

Table 7: TRANS Trip Generation Manual Recommended Mode Shares – Orleans

Travel Mode	Single-Detached		Multi-Unit (Low-Rise)	
	AM	PM	AM	PM
Auto Driver	48%	54%	47%	51%
Auto Passenger	14%	17%	15%	19%
Transit	27%	22%	29%	24%
Cycling	1%	1%	1%	1%

Travel Mode	Single-Detached		Multi-Unit (Low-Rise)	
	AM	PM	AM	PM
Walking	9%	6%	9%	6%
Total	100%	100%	100%	100%

5.2 Trip Generation

This TIA has been prepared using the vehicle and person trip rates for the residential dwellings using the TRANS Trip Generation Manual (2020). It is noted that a school and a commercial component each of unknown size are proposed within the development lands. No information or timelines are available for these components, and each will be subject to an eventual site plan application. Therefore, no trip generation will be undertaken for these future land uses. Table 8 summarizes the person trip rates for the proposed residential land uses for each peak period.

Table 8: Trip Generation Person Trip Rates by Peak Period

Land Use	Land Use Code	Peak Period	Person Trip Rates
Single-Detached	210 (TRANS)	AM	2.05
		PM	2.48
Multi-Unit (Low-Rise)	220 (TRANS)	AM	1.35
		PM	1.58

Using the above person trip rates, the total person trip generation has been estimated. Table 9 summarizes the total person trip generation for the residential land uses.

Table 9: Total Residential Person Trip Generation by Peak Period

Land Use	Units	AM Peak Period			PM Peak Period		
		In	Out	Total	In	Out	Total
Single-Detached	377	232	541	773	580	355	935
Multi-Unit (Low-Rise)	446	181	421	602	395	310	705

Using the above mode share targets for the person trip rates, the person trips by mode have been projected. Trip generation by peak hour has been forecasted using the prescribed peak period conversion factors presented in the TRANS Trip Generation Manual (2020) for the residential component. Table 10 summarizes the residential trip generation by mode.

Table 10: Residential Trip Generation by Mode

Travel Mode		AM Peak Hour				PM Peak Hour			
		Mode Share	In	Out	Total	Mode Share	In	Out	Total
Single-Detached	Auto Driver	48%	53	125	178	54%	138	84	222
	Auto Passenger	14%	15	36	52	17%	44	26	70
	Transit	27%	35	80	115	22%	60	37	97
	Cycling	1%	1	3	5	1%	3	2	4
	Walking	9%	12	28	41	6%	18	11	29
	Total	100%	116	271	387	100%	255	156	411
Multi-Unit (Low-Rise)	Auto Driver	47%	41	95	136	51%	88	70	158
	Auto Passenger	15%	13	30	43	19%	33	26	59
	Transit	29%	29	67	96	24%	45	35	79
	Cycling	1%	1	2	3	1%	2	1	3
	Walking	9%	9	22	31	6%	12	10	22
	Total	100%	91	211	301	100%	174	136	310

Travel Mode		AM Peak Hour				PM Peak Hour			
		Mode Share	In	Out	Total	Mode Share	In	Out	Total
Total	Auto Driver	-	94	220	314	-	226	154	380
	Auto Passenger	-	28	66	95	-	77	52	129
	Transit	-	64	147	211	-	105	72	176
	Cycling	-	2	5	8	-	5	3	7
	Walking	-	21	50	72	-	30	21	51
	Total	-	207	482	688	-	429	292	721

As shown above, a total of 314 new AM and 380 new PM peak hour two-way vehicle trips are projected as a result of the proposed development.

5.3 Trip Distribution

To understand the travel patterns of the subject development, the OD Survey has been reviewed to determine the travel for the residential component, and these patterns were applied based on the build-out of Orleans. Table 11 below summarizes the distributions.

Table 11: OD Survey Distribution – Orleans

To/From	Residential % of Trips
North	0%
South	15%
East	5%
West	80%
Total	100%

5.4 Trip Assignment

Using the distribution outlined above, turning movement splits, and access to major transportation infrastructure, the trips generated by the site have been assigned to the study area road network. Table 12 summarizes the proportional assignment to the study area roadways, and Figure 15 illustrates the new site generated volumes.

Table 12: Trip Assignment

To/From	Via
North	-
South	10% Cox Country Road (S), 5% Trim Road (S)
East	5% Old Montreal Road (E)
West	10% Old Montreal Road (W). 70% Trim Road (N)
Total	100%

Figure 15: New Site Generation Auto Volumes

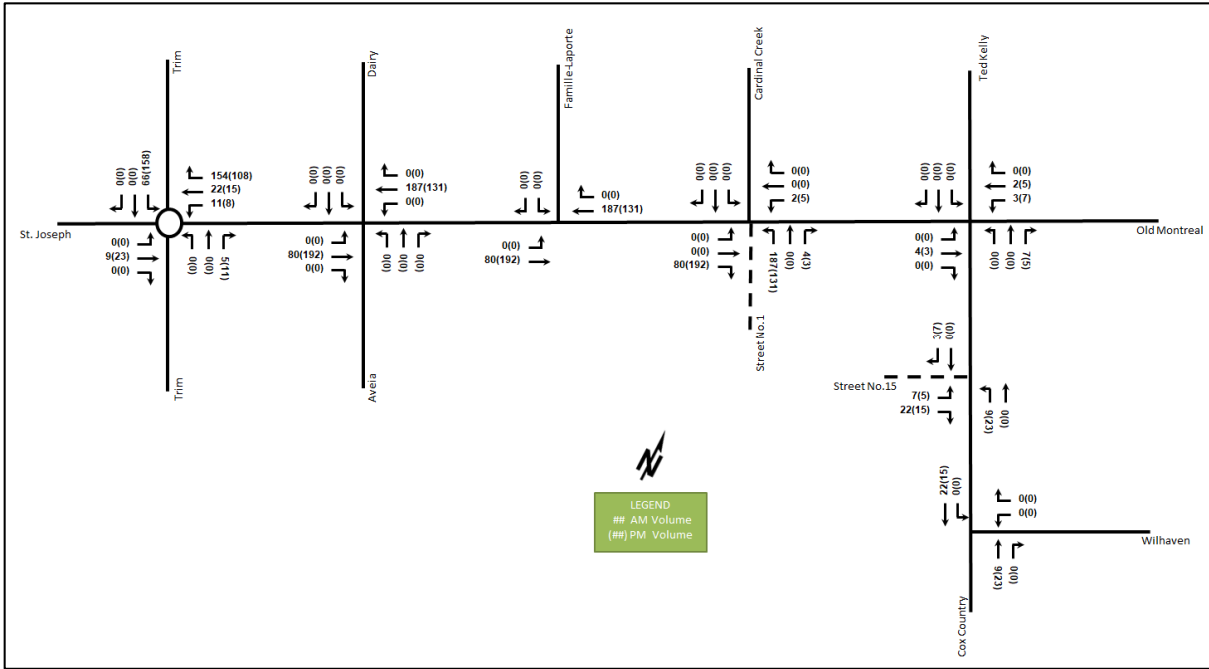

6 Background Network Travel Demands

6.1 Transportation Network Plans

The transportation network plans were discussed in Section 2.3 and have been incorporated into the road network analysis.

6.2 Background Growth

A review of the background projections from the City’s TRANS Regional Model for the 2011 and 2031 horizons was completed to determine the background growth for each of the study area roadways. The TRANS model plots are provided in Appendix F.

In general, the growth rates in the study area derived from the two TRANS model horizons are projected to be negative in the eastbound direction and positive in the northbound, southbound, and westbound directions. When reviewing the existing volumes to the 2031 model horizon, it is noted that growth forecasted in the westbound direction and northbound have been exceeded.

The adjacent area transportation studies have used a 1.8 % traffic growth along Old Montreal Road. Resultantly, growth rates rounded to the nearest 0.25% will be peak-directionally applied to the appropriate roadway’s mainline volumes and the appropriate major turning movements at the intersections. Table 13 summarizes the growth rates applied within the study area.

Table 13: TRANS Regional Model Projections – Study Area Growth Rates

Street	AM Peak Hour		PM Peak Hour	
	Eastbound	Westbound	Eastbound	Westbound
Old Montreal Road	-	2.00%	2.00%	-
St. Joseph Boulevard	-	2.00%	2.00%	-
	Northbound	Southbound	Northbound	Southbound
Trim Road	3.75%	-	-	3.75%

6.3 Other Developments

The background developments explicitly considered in the background conditions (Section 6.2) include:

- 1154, 1172, 1176, 1180, and 1208 Old Montreal Road
- 1015 Dairy Drive

The background volumes and other study area development volumes will be re-distributed in future horizons due to the network changes associated with the Realignment of Trim Road. Table 15 illustrates the 2027 and 2032 total reassigned volumes.

Figure 16: 2027 & 2032 Traffic Re-Assignment

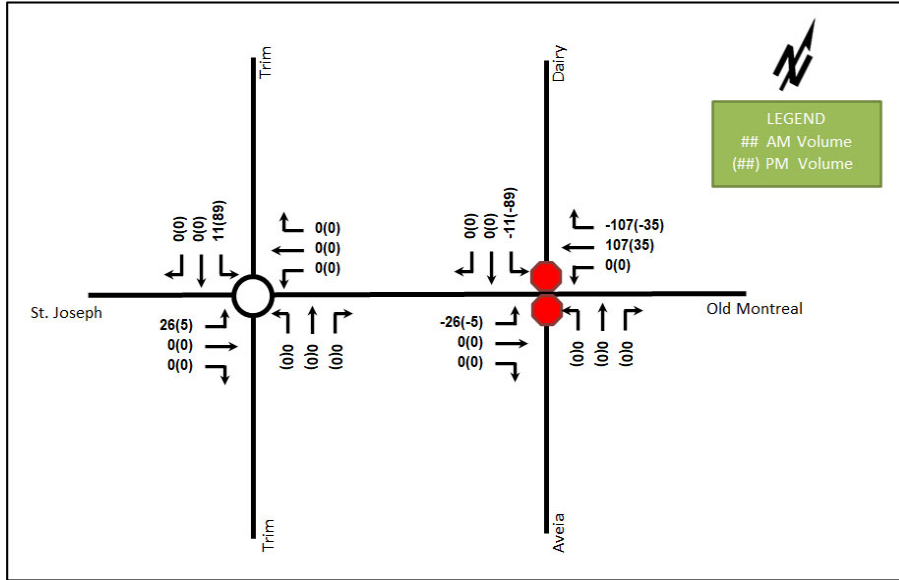

7 Demand Rationalization

7.1 2027 Future Background Operations

Figure 17 illustrates the 2027 background volumes and Table 14 summarizes the 2027 background intersection operations. Synchro 11 has been used to model the unsignalized intersections and Sidra 9 to model the study area roundabout. HCM 2010 methodology was used for unsignalized intersection operations and Sidra methodology was used for roundabout intersection operations. The Synchro and Sidra worksheets for the 2027 future background horizon are provided in Appendix G.

Figure 17: 2027 Future Background Volumes

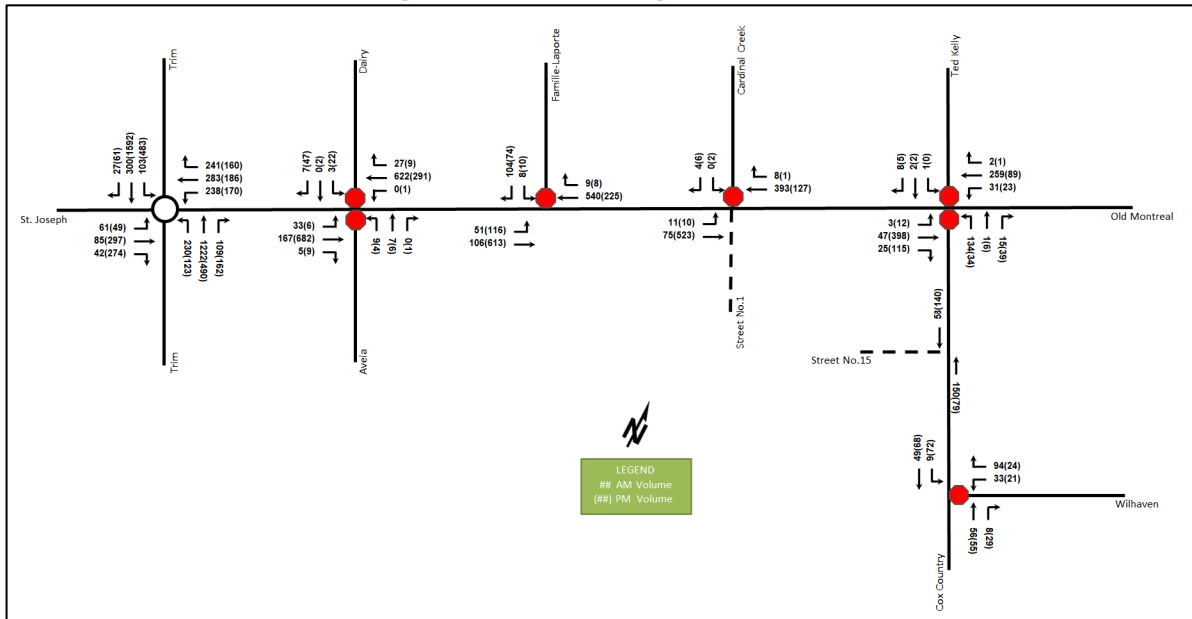

Table 14: 2027 Future Background Intersection Operations

Intersection	Lane	AM Peak Hour				PM Peak Hour			
		LOS	V/C	Delay	Q (95 th)	LOS	V/C	Delay	Q (95 th)
Trim Road & Old Montreal Road/St. Joseph Boulevard Roundabout	EB	A	0.06	6.7	2.0	B	0.46	13.4	26.5
	WB	A	0.37	8.9	14.4	A	0.18	6.8	6.0
	NB	A	0.60	5.5	26.1	A	0.44	7.2	18.1
	SB	A	0.25	7.3	9.0	C	1.01	29.2	217.2
	Overall	A	0.60	6.7	-	B	1.01	19.7	-
Aveia Private/Dairy Drive & Old Montreal Road Unsignalized	EBL	A	0.04	9.0	0.8	A	0.01	8.3	0.0
	EBT/R	-	-	-	-	-	-	-	-
	WBL	A	-	0.0	0.0	A	0.00	9.0	0.0
	WBT/R	-	-	-	-	-	-	-	-
	NB	C	0.06	19.5	1.5	C	0.05	21.1	0.8
	SBL	C	0.01	20.1	0.0	C	0.10	23.6	2.3
	SBT/R	B	0.02	12.7	0.0	B	0.07	10.8	1.5
Overall	A	-	0.9	-	A	-	1.3	-	
Famille-Laporte Avenue & Old Montreal Road Unsignalized	EBL	A	0.05	8.9	1.5	A	0.09	8.0	2.3
	EBT	-	-	-	-	-	-	-	-
	WB	-	-	-	-	-	-	-	-
	SB	B	0.22	14.0	6.0	B	0.14	11.8	3.8
	Overall	A	-	2.5	-	A	-	1.9	-
Cardinal Creek Drive & Old Montreal Road Unsignalized	EB	A	0.01	8.5	0.0	A	0.01	7.6	0.0
	WB	-	-	-	-	-	-	-	-
	SB	B	0.01	12.0	0.0	B	0.01	10.7	0.0
	Overall	A	-	0.3	-	A	-	0.2	-
Ted Kelly Lane/ Cox Country Road & Old Montreal Road Unsignalized	EB	A	0.00	7.8	0.0	A	0.01	7.4	0.0
	WB	A	0.02	7.4	0.8	A	0.02	8.5	0.8
	NB	B	0.26	13.5	7.5	B	0.17	14.2	4.5
	SB	B	0.02	10.3	0.0	B	0.01	10.5	0.0
	Overall	A	-	4.5	-	A	-	2.1	-

Intersection	Lane	AM Peak Hour				PM Peak Hour			
		LOS	V/C	Delay	Q (95 th)	LOS	V/C	Delay	Q (95 th)
Cox Country Road & Wilhaven Drive <i>Unsignalized</i>	WB	A	0.13	9.4	3.8	A	0.06	9.7	1.5
	NB	-	-	-	-	-	-	-	-
	SB	A	0.01	7.4	0.0	A	0.05	7.5	0.8
	Overall	A	-	5.1	-	A	-	3.7	-

Notes: Saturation flow rate of 1800 veh/h/lane
 Peak Hour Factor = 1.00
 Queue is measured in metres
 m = metered queue
 # = volume for the 95th %ile cycle exceeds capacity

During both the AM and PM peak hours at the 2027 future background horizon, the study area intersections operate similarly to the existing conditions.

7.2 2032 Future Background Operations

Figure 18 illustrates the 2032 background volumes and Table 15 summarizes the 2032 background intersection operations. Synchro 11 has been used to model the unsignalized intersections and Sidra 9 to model the study area roundabout. HCM 2010 methodology was used for unsignalized intersection operations and Sidra methodology was used for roundabout intersection operations. The Synchro and Sidra worksheets for the 2032 future background horizon are provided in Appendix H.

Figure 18: 2032 Future Background Volumes

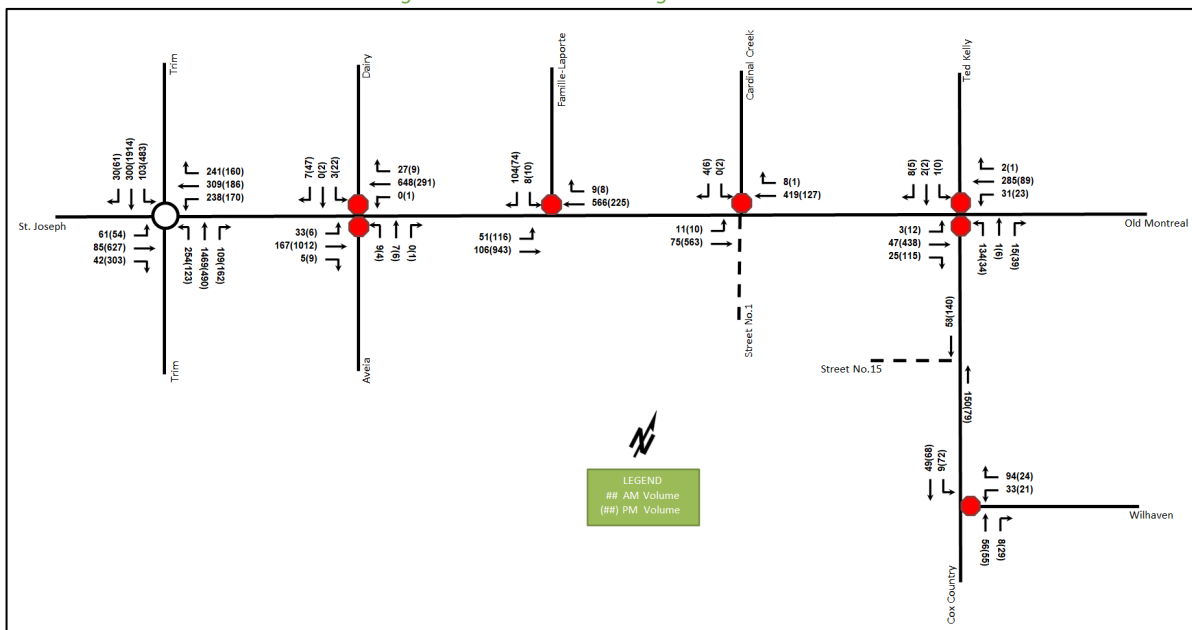

Table 15: 2032 Future Background Intersection Operations

Intersection	Lane	AM Peak Hour				PM Peak Hour			
		LOS	V/C	Delay	Q (95 th)	LOS	V/C	Delay	Q (95 th)
Trim Road & Old Montreal Road/St. Joseph Boulevard <i>Roundabout</i>	EB	A	0.06	6.7	2.0	C	0.86	27.8	76.4
	WB	B	0.46	10.5	19.6	A	0.18	6.8	6.2
	NB	A	0.70	6.0	40.2	A	0.50	8.2	22.0
	SB	A	0.26	7.5	9.6	F	1.16	85.0	521.8
	Overall	A	0.70	7.4	-	E	1.16	52.0	-

Intersection	Lane	AM Peak Hour				PM Peak Hour			
		LOS	V/C	Delay	Q (95 th)	LOS	V/C	Delay	Q (95 th)
Aveia Private/Dairy Drive & Old Montreal Road Unsignalized	EBL	A	0.04	9.1	0.8	A	0.01	8.3	0.0
	EBT/R	-	-	-	-	-	-	-	-
	WBL	A	-	0.0	0.0	B	0.00	10.3	0.0
	WBT/R	-	-	-	-	-	-	-	-
	NB	C	0.06	20.1	1.5	D	0.08	32.3	1.5
	SBL	C	0.01	20.7	0.0	E	0.18	39.5	4.5
	SBT/R	B	0.02	12.9	0.0	B	0.08	11.2	2.3
Overall	A	-	0.9	-	A	-	1.3	-	
Famille-Laporte Avenue & Old Montreal Road Unsignalized	EBL	A	0.05	9.0	1.5	A	0.09	8.0	2.3
	EBT	-	-	-	-	-	-	-	-
	WB	-	-	-	-	-	-	-	-
	SB	B	0.23	14.5	6.8	B	0.16	13.3	4.5
	Overall	A	-	2.5	-	A	-	1.5	-
Cardinal Creek Drive & Old Montreal Road Unsignalized	EB	A	0.01	8.6	0.0	A	0.01	7.6	0.0
	WB	-	-	-	-	-	-	-	-
	SB	B	0.01	12.2	0.0	B	0.01	10.8	0.0
	Overall	A	-	0.3	-	A	-	0.2	-
Ted Kelly Lane/ Cox Country Road & Old Montreal Road Unsignalized	EB	A	0.00	7.8	0.0	A	0.01	7.4	0.0
	WB	A	0.02	7.4	0.8	A	0.02	8.6	0.8
	NB	B	0.27	13.9	8.3	B	0.18	14.9	4.5
	SB	B	0.02	10.5	0.8	B	0.01	10.7	0.0
	Overall	A	-	4.4	-	A	-	2.1	-
Cox Country Road & Wilhaven Drive Unsignalized	WB	A	0.13	9.4	3.8	A	0.06	9.7	1.5
	NB	-	-	-	-	-	-	-	-
	SB	A	0.01	7.4	0.0	A	0.05	7.5	1.5
	Overall	A	-	5.1	-	A	-	3.7	-

Notes: Saturation flow rate of 1800 veh/h/lane
 Peak Hour Factor = 1.00
 Queue is measured in metres

m = metered queue
 # = volume for the 95th %ile cycle exceeds capacity

During both the AM and PM peak hours at the 2032 future background horizon, the study area intersections operate similarly to the 2027 future background horizon with the exception of the Trim Road roundabout. The southbound approached delays will increase from 29.2 seconds to 85.0 seconds and queues will increase from 217.2 metres to 521.8 metres during the PM peak as the result of background growth along Trim Road. As a roundabout intersection, limited opportunity exists to change the intersection configuration and any operational improvements will need to be a result of network volume reductions within Orleans.

7.3 Modal Share Sensitivity

The southbound approach at the Trim Road & Old Montreal Road/St. Joseph Boulevard roundabout is noted to have high delays and extended queueing during the PM peak hour in the 2032 future background conditions as background traffic increases. A modal shift will be required to reduce auto dependency in this area and may be achieved by the Stage 2 LRT opening. The City should monitor the operations as volumes and development increase, in addition to the network changes completed as part of the Trim Road realignment. No adjustments to the trip generation and modal shares are recommended as a result of these conditions.

8 Development Design

8.1 Design for Sustainable Modes

The proposed development is a residential subdivision where each dwelling will include a driveway and garage. Bicycle parking is assumed to be within the individual units. Figure 19 illustrates the minimum recommended pedestrian and recommended cycling concept networks for the community.

Figure 19: Concept Pedestrian and Cycling Network

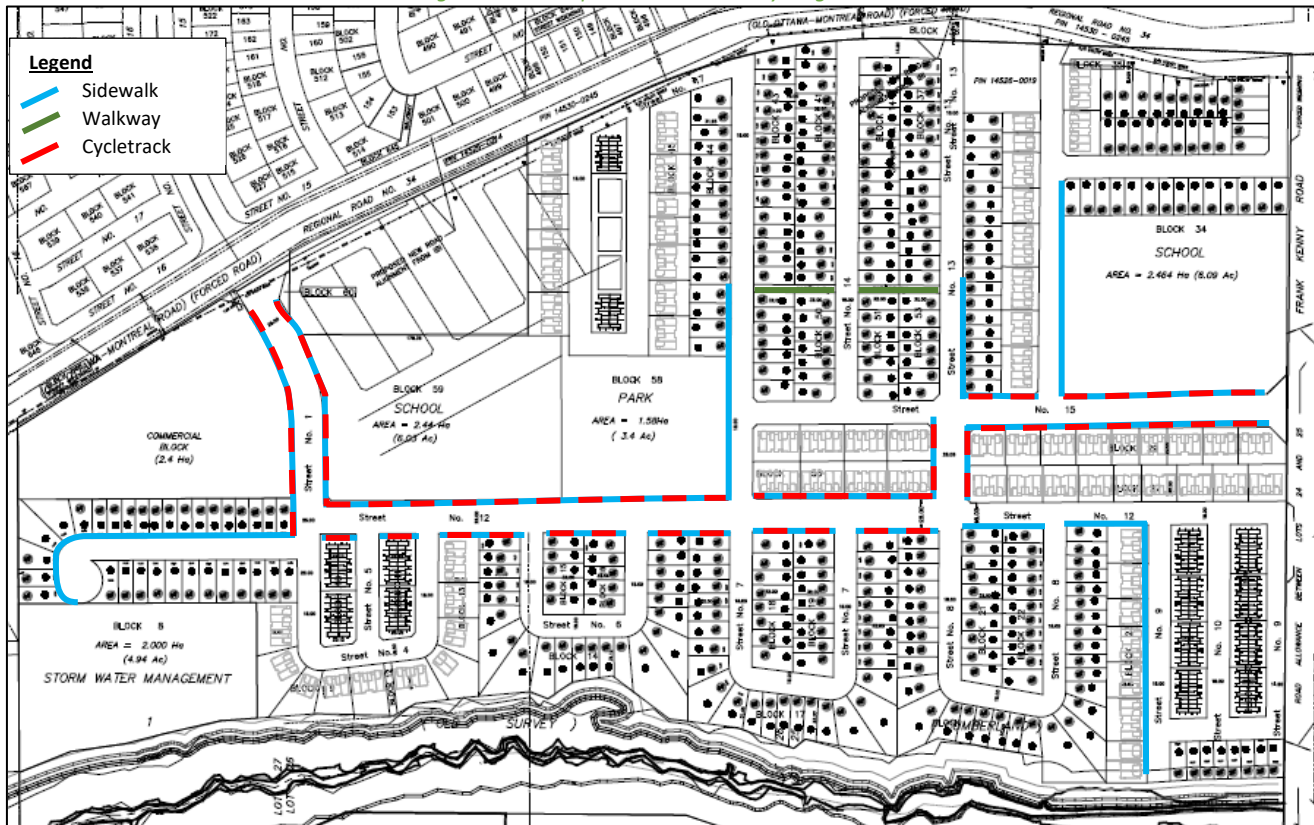

8.2 New Street Networks

The planned street network will include a mix of 14.8-metre window streets, 18.0-metre local roads, with 26.0-metre collector road connections to area road network. The local roads will provide the opportunity for parking on one side of the roadway. The subdivision is considered to be designed for 30 km/h roadways.

To support the pedestrian and cycling connectivity within the subdivision, Figure 20 illustrates the concept traffic calming plan. Traffic calming elements are recommended at the internal intersections, including bulb-outs to narrow each approach to the intersection (e.g. reduced crossing distance). On-street parking is undefined within these concepts. Once the road network pattern and lotting concepts are confirmed, the on-street parking can be outlined in the geometric roadway design. The location of speed humps is subject to minor changes and will need to be refined as part of the detailed engineering submission once the locations of the driveway, stormwater flows, surface ponding, and servicing elements, such as utilities and fire hydrants, have been established.

The internal road intersections are recommended to be stop-controlled on the minor approaches of all intersections.

Figure 20: Concept Traffic Calming Plan

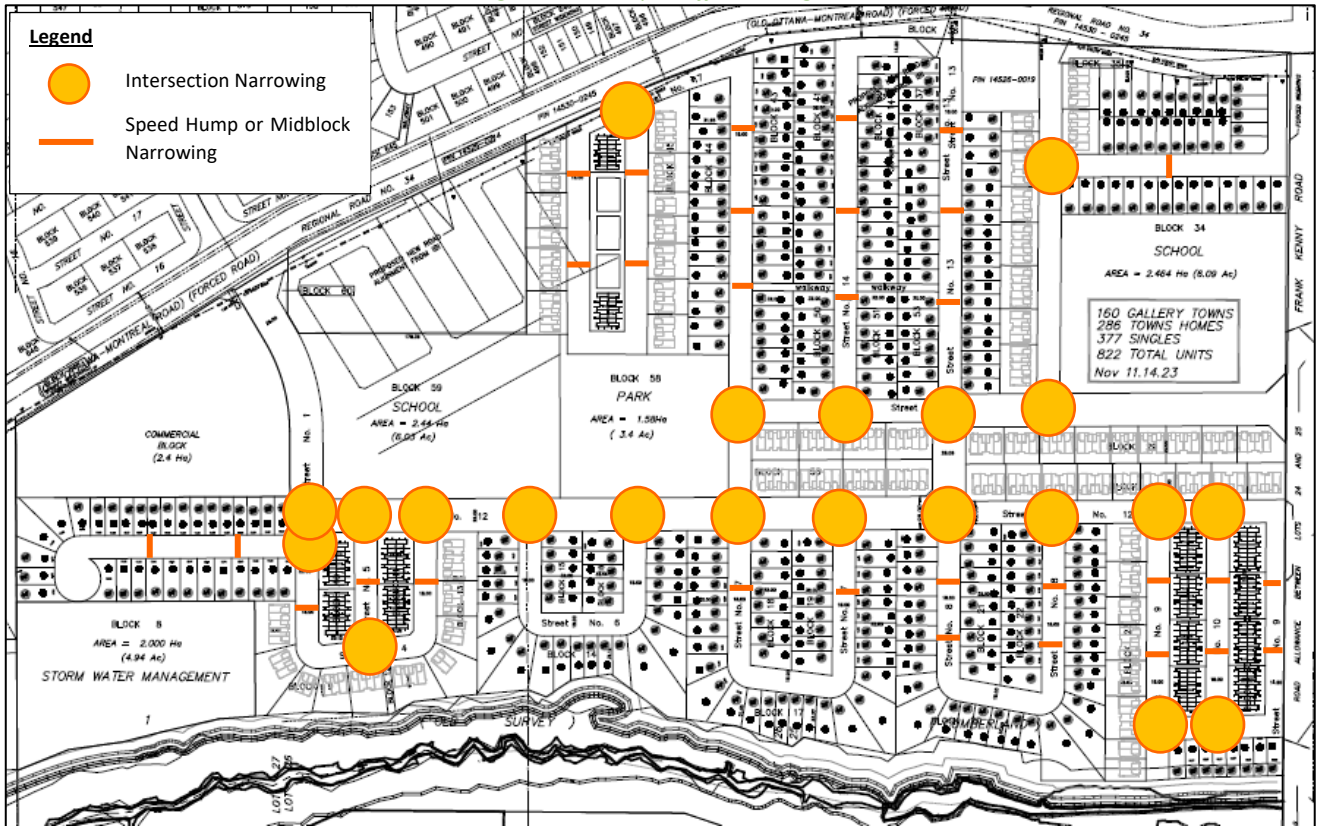

9 Boundary Street Design

Table 16 summarizes the MMLOS analysis for the boundary streets of Old Montreal Road and Cox Country Road. The existing and future conditions for both streets will be the same and are considered in one row. The boundary street analysis is based on the policy area of “Within 300m of a school” in a Developing Community. The MMLOS worksheets have been provided in Appendix I.

Table 16: Boundary Street MMLOS Analysis

Segment	Pedestrian LOS		Bicycle LOS		Transit LOS		Truck LOS	
	PLOS	Target	BLOS	Target	TLOS	Target	TrLOS	Target
Old Montreal Road (Existing)	F	A	F	C	N/A	N/A	B	D
Old Montreal Road (Future Widening)	D	A	A	C	A	A	C	D
Cox Country Road	F	A	F	B	N/A	N/A	N/A	N/A

The pedestrian LOS targets will not meet the area targets along boundary streets. To meet pedestrian LOS targets, all roadways will need 2 metre sidewalks, greater than 2 metres of boulevard space and speed reductions to less than 30 km/h.

The bicycle LOS targets will not be met along segment of Old Montreal Road in existing condition and require bike lanes and operating speeds to be between 50-70 km/h. The targets are expected to be met once Old Montreal Road is widened. The targets will not be met along the segment of Cox Country Road and the operating speed has to be reduced to less or equal to 50 km/h or bike lanes provided with operating speeds between 50-70 km/h to meet these targets.

10 Access Intersections Design

10.1 Location and Design of Access

The residential accesses will connect via new collector roads to Old Montreal Road and to Cox Country Road. As part of the work supporting Phases 5 and 6 of the Cardinal Creek Village north of Old Montreal Road, the eastbound left-turn lane is subject to a monitoring exercise for meeting warrants. The warrants have been met and an eastbound left-turn lane with 50 metres of storage is recommended to be provided at the intersection. Along with this lane, an opposing westbound left-turn lane is recommended to be provided for lane alignment.

Additionally, as noted in Section 10.3.1 and 10.3.2, a high number of eastbound right turns associated with the subject development (192 during a peak hour) are forecast at this intersection, constituting a high proportion of the advancing volumes (approximately 27%). Therefore, an auxiliary eastbound right-turn lane is recommended to be added to the scope of the RMA works pending for this intersection as part of the monitoring program, and this lane has been assumed within future total conditions.

The residential driveways will connect directly to the internal road network. Within the subdivision, no turn lanes are proposed for the internal intersections which will be controlled by minor stop control.

10.2 Intersection Control

The intersection of Cardinal Creek Drive/Street No.1 at Old Montreal Road and Cox Country Road at Street No.15 proposed to remain a minor stop-controlled intersection as they do not warrant signalization. The internal intersections within the subdivision are to be minor stop-controlled. Signal warrants are provided in Appendix J.

10.3 Access Intersection Design

10.3.1 2027 Future Total Access Intersection Operations

The 2027 future total intersection volumes are illustrated in Figure 21 and the access intersection operations are summarized below in Table 17. Synchro 11 has been used to model the unsignalized intersections and HCM 2010 methodology was used for unsignalized intersection operations. The synchro worksheets have been provided in Appendix K.

Figure 21: 2027 Future Total Volumes

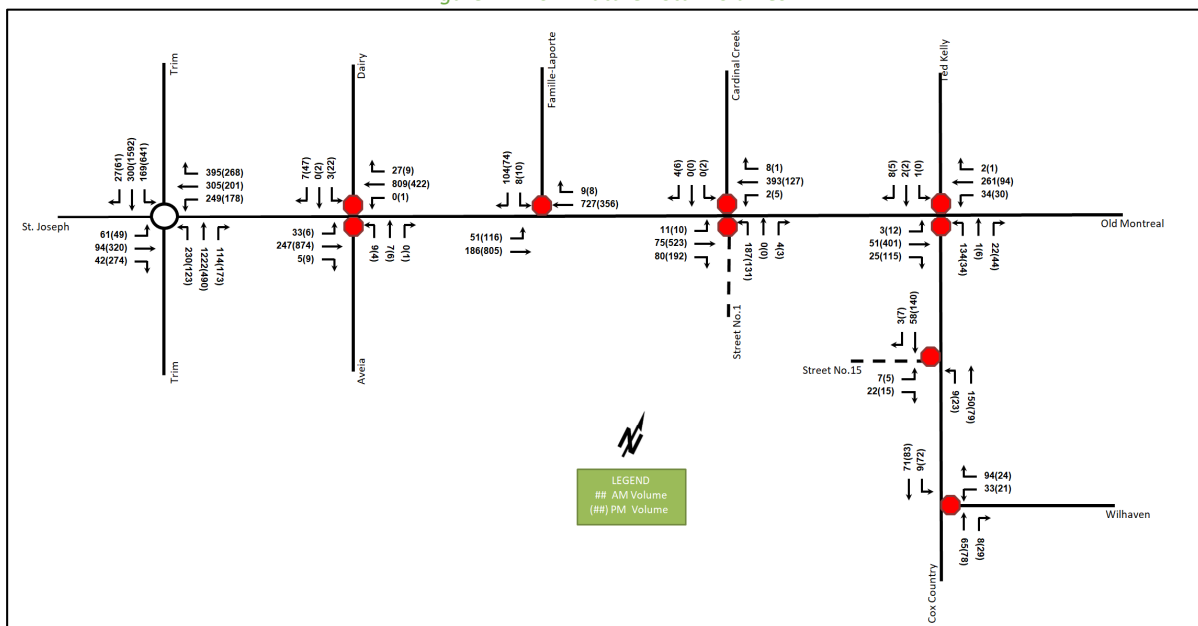

Table 17: 2027 Future Total Access Intersection Operations

Intersection	Lane	AM Peak Hour				PM Peak Hour			
		LOS	V/C	Delay	Q (95 th)	LOS	V/C	Delay	Q (95 th)
Cardinal Creek Drive/ Street No.1 & Old Montreal Road <i>Unsignalized</i>	EBL	A	0.01	8.5	0.0	A	0.01	7.6	0.0
	EBT	-	-	-	-	-	-	-	-
	EBR	-	-	-	-	-	-	-	-
	WBL	A	0.00	7.5	0.0	A	0.01	9.1	0.0
	WBT/R	-	-	-	-	-	-	-	-
	NB	C	0.40	17.5	14.3	C	0.37	20.8	12.8
	SB	B	0.01	12.0	0.0	B	0.02	11.6	0.0
Overall	A	-	4.6	-	A	-	3.0	-	
Cox Country Road & Street No.15 <i>Unsignalized</i>	EB	A	0.03	9.0	0.8	A	0.02	9.4	0.8
	NB	A	0.01	7.3	0.0	A	0.02	7.5	0.0
	SB	-	-	-	-	-	-	-	-
	Overall	A	-	1.3	-	A	-	1.3	-

Notes: Saturation flow rate of 1800 veh/h/lane
 Peak Hour Factor = 1.00
 Queue is measured in metres
 m = metered queue
 # = volume for the 95th %ile cycle exceeds capacity

The 2027 future total access intersections operate satisfactorily.

10.3.2 2032 Future Total Access Intersection Operations

The 2032 future total intersection volumes are illustrated in Figure 22 and the access intersection operations are summarized below in Table 18. Synchro 11 has been used to model the unsignalized intersections and the HCM 2010 methodology was used for unsignalized intersection operations. The synchro worksheets have been provided in Appendix L.

Figure 22: 2032 Future Total Volumes

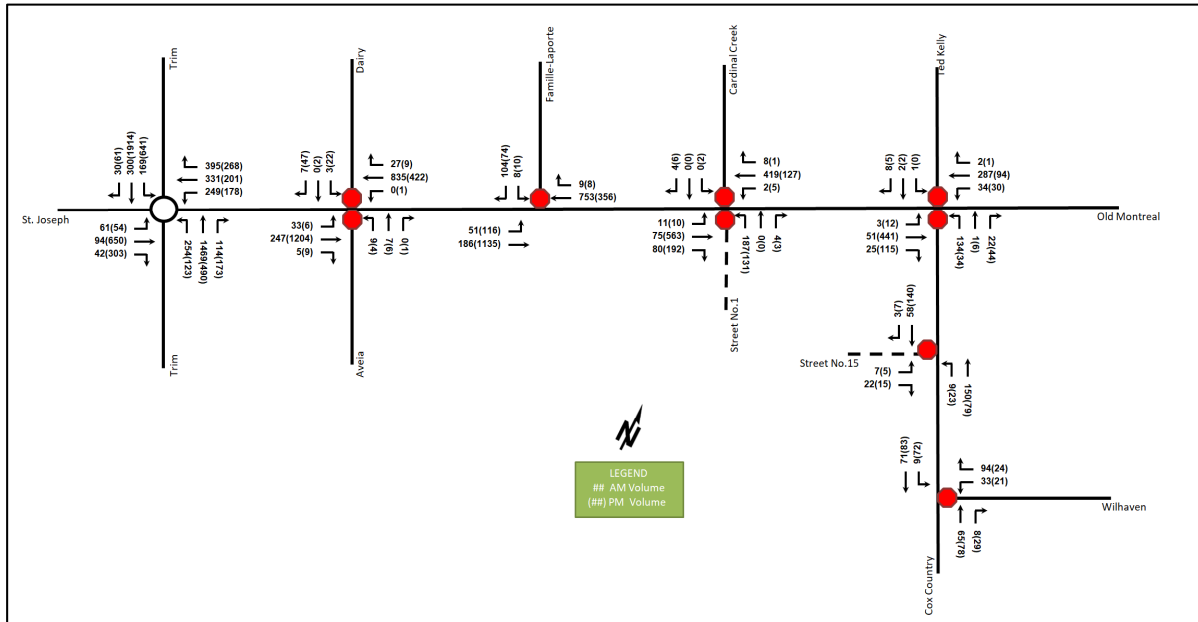

Table 18: 2032 Future Total Access Intersection Operations

Intersection	Lane	AM Peak Hour				PM Peak Hour			
		LOS	V/C	Delay	Q (95 th)	LOS	V/C	Delay	Q (95 th)
Cardinal Creek Drive/ Street No.1 & Old Montreal Road <i>Unsignalized</i>	EBL	A	0.01	8.6	0.0	A	0.01	7.6	0.0
	EBT	-	-	-	-	-	-	-	-
	EBR	-	-	-	-	-	-	-	-
	WBL	A	0.00	7.5	0.0	A	0.01	9.2	0.0
	WBT/R	-	-	-	-	-	-	-	-
	NB	C	0.42	18.3	15.0	C	0.40	22.5	13.5
	SB	B	0.01	12.2	0.0	B	0.02	11.9	0.0
	Overall	A	-	4.6	-	A	-	3.1	-
Cox Country Road & Street No.15 <i>Unsignalized</i>	EB	A	0.03	9.0	0.8	A	0.02	9.4	0.8
	NB	A	0.01	7.3	0.0	A	0.02	7.5	0.0
	SB	-	-	-	-	-	-	-	-
	Overall	A	-	1.3	-	A	-	1.3	-

Notes: Saturation flow rate of 1800 veh/h/lane m = metered queue
 Peak Hour Factor = 1.00 # = volume for the 95th %ile cycle exceeds capacity
 Queue is measured in metres

The 2032 future total access intersections operate satisfactorily.

10.3.3 Access Intersection MMLOS

The access intersections are proposed to as minor stop-controlled intersections, therefore no access intersection MMLOS analysis has been conducted.

10.3.4 Recommended Design Elements

The storage lengths for the auxiliary turn lanes at the intersection of Cardinal Creek Drive/Street No.1 at Old Montreal Road serving the subject community will be based on equation 9.14.1 from the Geometric Design Guide for Canadian Roads (TAC, 2017), assuming 1.5 times the forecasted volumes in line with the TIA Guidelines’ evaluation parameters. Based on these sources, the calculated storage length for the eastbound right-turn lane is 67.2 metres, and the calculated storage for the westbound left-turn lane is 1.75 metres. Ninety-fifth percentile queues on these movements are forecast to be negligible, per the operations in Sections 10.3.1 and 10.3.2. Therefore, the recommended storage lengths at the intersection of Cardinal Creek Drive/Street No.1 at Old Montreal Road are 70 metres for the eastbound right-turn lane, and the minimum 37.5 metres for the westbound left-turn lane.

11 Transportation Demand Management

11.1 Context for TDM

The mode shares used within the TIA represent the unmodified district mode shares. Overall, the modal shares are likely to be achieved and supporting TDM measures should be provided to encourage shifts towards sustainable modes.

The subject site is within the Cardinal Creek Village Community Design Plan area and is not within a design priority area. The total bedroom count within the development is subject to the final unit breakdown and layout selections by purchasers. No age restrictions are noted.

11.2 Need and Opportunity

The subject site has been assumed to rely predominantly on auto travel and those assumptions have been carried through the analysis. The study area intersections are anticipated to have the residual capacity, and as the

unmodified district mode shares have been applied, risks to other network users from failing to meet mode share targets are low.

11.3 TDM Program

The “suite of post occupancy TDM measures” has been summarized in the TDM checklists for the residential land uses. The checklist is provided in Appendix M. The key TDM measures recommended include:

- Inclusion of a 1-year Presto card for first time new townhome purchase, with a set time frame for this offer (e.g. 6-months) from the initial opening of the site
- Contract with OC Transpo to provide early transit services until regular services are warranted by occupancy levels
- Provide a multimodal travel option information package to new residents

12 Neighbourhood Traffic Management

Site traffic is proposed to access the arterial network via Cox Country Road. The TIA Guidelines propose a threshold of 300 vehicles per peak hour for the classification of collector roads, which per City guidance is to be interpreted as two-way volumes.

The existing volumes on Cox Country Road are 210 two-way vehicles in the AM peak hour and 204 two-way vehicles in the PM peak hour. Overall, the site is anticipated to generate approximately 37 and 44 two-way vehicle trips during the AM and PM peak hours, respectively, all of which will access Cox Country Road. These volumes are below the threshold of 2,500 vehicles per day or 300 vehicles during the peak hour, equivalent to 5 cars per minute in both directions total from the TIA guidelines, and thus no further discussion is required.

13 Transit

13.1 Route Capacity

In Section 5.1 the trip generation by mode was estimated, including an estimate of the number of transit trips that will be generated by the proposed development. Table 19 summarizes the transit trip generation.

Table 19: Trip Generation by Transit Mode

Travel Mode	Mode Share	AM Peak Period			PM Peak Period		
		In	Out	Total	In	Out	Total
Transit	Varies	64	147	211	105	72	176

The proposed development is anticipated to generate an additional 211 AM peak hour transit trips and 176 PM peak hour transit trips. Of these trips, 147 outbound AM trips and 105 inbound PM trips are anticipated.

Existing bus service in the area is reflective of the state of build-out of the developing community. It is anticipated that bus service will increase as the ridership base increases in the area. Bus route #221 provides two buses in the peak hour/ direction. Overall, the forecasted new transit trips would result in the need for approximately three to four single capacity buses across each peak hour to service the entire route.

13.2 Transit Priority

No significant impacts are noted to the traffic movements that currently support transit movements in the study area. No transit priority is recommended as part of this study.

14 Network Concept

The subject development is consistent with the intended context set by the Cardinal Creek Village Plan. The background and forecasted site trips do not exceed the anticipated lane capacities on the boundary road network. No changes to the network concept are required to support this project.

15 Network Intersection Design

15.1 Network Intersection Control

No change is recommended for the network intersections.

15.2 Network Intersection Design

15.2.1 2027 Future Total Network Intersection Operations

The 2027 future total network intersection operations are summarized below in Table 20. Synchro 11 has been used to model the unsignalized intersections and Sidra 9 to model the study area roundabout. HCM 2010 methodology was used for unsignalized intersection operations and Sidra methodology was used for roundabout intersection operations. The Synchro and Sidra worksheets for the 2027 future total horizon have been provided in Appendix K.

Table 20: 2027 Future Total Network Intersection Operations

Intersection	Lane	AM Peak Hour				PM Peak Hour			
		LOS	V/C	Delay	Q (95 th)	LOS	V/C	Delay	Q (95 th)
Trim Road & Old Montreal Road/St. Joseph Boulevard Roundabout	EB	A	0.07	6.7	2.3	A	0.46	13.1	26.5
	WB	A	0.41	8.6	16.5	A	0.20	6.5	7.4
	NB	B	0.63	6.2	31.2	A	0.49	8.2	23.0
	SB	A	0.29	8.1	11.0	E	1.10	59.9	375.9
	Overall	A	0.63	7.2	-	D	1.10	35.8	-
Aveia Private/Dairy Drive & Old Montreal Road Unsignalized	EBL	A	0.04	9.7	0.8	A	0.01	8.7	0.0
	EBT/R	-	-	-	-	-	-	-	-
	WBL	A	-	0.0	0.0	A	0.00	9.7	0.0
	WBT/R	-	-	-	-	-	-	-	-
	NB	D	0.09	27.4	2.3	D	0.08	31.9	1.5
	SBL/T	D	0.02	28.5	0.8	E	0.17	38.9	4.5
	SBT/R	B	0.02	14.9	0.8	B	0.09	12.3	2.3
Overall	A	-	0.8	-	A	-	1.4	-	
Famille-Laporte Avenue & Old Montreal Road Unsignalized	EBL	A	0.06	9.6	1.5	A	0.10	8.4	2.3
	EBT	-	-	-	-	-	-	-	-
	WB	-	-	-	-	-	-	-	-
	SB	C	0.29	17.8	9.0	B	0.18	14.4	4.5
	Overall	A	-	2.3	-	A	-	1.6	-
Ted Kelly Lane/ Cox Country Road & Old Montreal Road Unsignalized	EB	A	0.00	7.8	0.0	A	0.01	7.4	0.0
	WB	A	0.02	7.4	0.8	A	0.03	8.5	0.8
	NB	B	0.27	13.6	8.3	B	0.18	14.5	5.3
	SB	B	0.02	10.3	0.0	B	0.01	10.7	0.0
	Overall	A	-	4.7	-	A	-	2.2	-

Intersection	Lane	AM Peak Hour				PM Peak Hour			
		LOS	V/C	Delay	Q (95 th)	LOS	V/C	Delay	Q (95 th)
Cox Country Road & Wilhaven Drive Unsignalized	WB	A	0.14	9.5	3.8	A	0.06	9.9	1.5
	NB	-	-	-	-	-	-	-	-
	SB	A	0.01	7.4	0.0	A	0.05	7.6	1.5
	Overall	A	-	4.5	-	A	-	3.2	-

Notes: Saturation flow rate of 1800 veh/h/lane
Peak Hour Factor = 1.00
Queue is measured in metres

m = metered queue
= volume for the 95th %ile cycle exceeds capacity

During both the AM and PM peak hours at the 2027 future total horizon, the study area intersections operate similarly to the 2027 future background conditions.

15.2.2 2032 Future Total Network Intersection Operations

The 2032 future total network intersection operations are summarized below in Table 21. Synchro 11 has been used to model the unsignalized intersections and Sidra 9 to model the study area roundabout. HCM 2010 methodology was used for unsignalized intersection operations and Sidra methodology was used for roundabout intersection operations. The Synchro and Sidra worksheets for the 2032 future total horizon have been provided in Appendix L.

Table 21: 2032 Future Total Network Intersection Operations

Intersection	Lane	AM Peak Hour				PM Peak Hour			
		LOS	V/C	Delay	Q (95 th)	LOS	V/C	Delay	Q (95 th)
Trim Road & Old Montreal Road/St. Joseph Boulevard Roundabout	EB	A	0.07	6.7	2.3	C	0.87	28.3	80.5
	WB	B	0.51	10.6	23.5	A	0.20	6.5	7.5
	NB	A	0.74	7.0	48.1	A	0.54	9.2	25.5
	SB	A	0.31	8.2	11.9	F	1.25	125.4	731.9
	Overall	A	0.74	6.8	-	F	1.25	72.8	-
Aveia Private/Dairy Drive & Old Montreal Road Unsignalized	EBL	A	0.04	9.8	0.8	A	0.01	8.7	0.0
	EBT/R	-	-	-	-	-	-	-	-
	WBL	A	-	0.0	0.0	B	0.00	11.3	0.0
	WBT/R	-	-	-	-	-	-	-	-
	NB	D	0.09	28.4	2.3	F	0.13	51.7	3.0
	SBL/T	D	0.02	29.7	0.8	F	0.30	74.3	8.3
	SBT/R	C	0.02	15.2	0.8	B	0.10	12.9	2.3
Overall	A	-	0.8	-	A	-	1.6	-	
Famille-Laporte Avenue & Old Montreal Road Unsignalized	EBL	A	0.06	9.7	1.5	A	0.10	8.4	2.3
	EBT	-	-	-	-	-	-	-	-
	WB	-	-	-	-	-	-	-	-
	SB	C	0.30	18.4	9.0	C	0.22	17.3	6.0
	Overall	A	-	2.3	-	A	-	1.4	-
Ted Kelly Lane/ Cox Country Road & Old Montreal Road Unsignalized	EB	A	0.00	7.8	0.0	A	0.01	7.4	0.0
	WB	A	0.02	7.4	0.8	A	0.03	8.7	0.8
	NB	B	0.28	14.1	9.0	C	0.19	15.2	5.3
	SB	B	0.02	10.5	0.8	B	0.01	10.8	0.0
	Overall	A	-	4.6	-	A	-	2.2	-

Intersection	Lane	AM Peak Hour				PM Peak Hour			
		LOS	V/C	Delay	Q (95 th)	LOS	V/C	Delay	Q (95 th)
Cox Country Road & Wilhaven Drive <i>Unsignalized</i>	WB	A	0.14	9.5	3.8	A	0.06	9.9	1.5
	NB	-	-	-	-	-	-	-	-
	SB	A	0.01	7.4	0.0	A	0.05	7.6	1.5
	Overall	A	-	4.5	-	A	-	3.2	-

Notes: Saturation flow rate of 1800 veh/h/lane
Peak Hour Factor = 1.00
Queue is measured in metres

m = metered queue
= volume for the 95th %ile cycle exceeds capacity

The delays and queuing during the PM peak hour at the Trim Road & Old Montreal Road/St. Joseph Boulevard roundabout will increase with the additional site traffic. As a roundabout intersection, limited opportunity exists to change the intersection configuration, and any operational improvements will need to be a result of network volume reductions within Orleans, which are anticipated to be possible with the opening of the LRT line.

The Old Montreal Road and Aveia Private/Dairy Drive intersection on the northbound movement and southbound shared left-turn/through movement may be subject to high delays during the PM peak hour.

15.2.3 Network Intersection MMLOS

No changes to the network intersection control are proposed as part of this study.

15.2.4 Recommended Design Elements

No study area intersection design elements are proposed as part of this study.

16 Summary of Improvements Indicated and Modifications Options

The following summarizes the analysis and results presented in this TIA report:

Proposed Site and Screening

- The proposed site includes 446 townhome units, and 377 single detached units
- Two proposed new collector roads will be access on Old Montreal Road and Cox Country Road
- The anticipated full build-out and occupancy horizon is 2027 with construction occurring in five phases
- The trip generation and safety triggers were met for the TIA Screening

Existing Conditions

- Old Montreal Road, St Joseph Boulevard, Trim Road are arterial roads, Cardinal Creek Drive is a major collector road, and Cox Country Road, Wilhaven Drive, Famille-Laporte Avenue are collector roads in the study area
- A sidewalk and multi-use pathway are provided along the north and south sides of Old Montreal Road, respectively, between Trim Road and Aveia Private/Dairy Drive
- Paved shoulders are provided along Cox Country Road and Old Montreal Road between Dairy Drive/ Aveia Private and Cox Country Road, and a bike lane is provided east of Dairy along Old Montreal Road
- The Old Montreal Road and Cox Country Road are both designated as spine routes, and Wilhaven Drive is a local route within the 2013 TMP
- There are a total of 24 collisions within the study area. The segment of Old Montreal Road between Grand Chene Cour Du Court and Ted Kelly Lane is noted to have experienced higher collisions than other intersections, which has 29% of the collisions within the study area
- During both the AM and PM peak hours, the study area intersection at existing conditions operates well

Planned Conditions

- The RMA works associated with Cardinal Creek Village Phase 4 improvements to the intersection of Old Montreal Road include:
 - an eastbound left-turn lane,
 - the provision of pavement for the opposing westbound left-turn lane geometry for lane alignment,
 - the provision of pavement for an eastbound right-turn lane supporting the future addition of a south leg to the intersection,
 - the widening of the paved shoulder throughout the area of modifications, and
 - the signal plant for future signal infrastructure

Development Generated Travel Demand

- The proposed development is forecasted to produce 688 two-way people trips during the AM peak hour and 721 two-way people trips during the PM peak hour
- Of the forecasted people trips, 314 two-way trips will be vehicle trips during the AM peak hour and 380 two-way trips will be vehicle trips during the PM peak hour
- Of the forecasted trips, 15% are anticipated to travel south, 5% to the east, and 80% to the west

Background Conditions

- The background developments were explicitly included in the background conditions, along with a total background growth of 2% per annum on existing Old Montreal Road and St. Joseph Boulevard mainline volumes, and a total background growth of 3.75% per annum on existing Trim Road mainline volumes
- The Trim Road roundabout will experience high delays during the PM peak in the 2032 background conditions and the remaining study area intersections have no operational issues noted

Development Design

- A driveway and garage will be included in each dwelling
- Bicycle parking is assumed to be within the individual units
- Pedestrian connections, cycletracks, and walkways will be made to the storm water management, park, school, and creek
- The planned street network will include a mix of 14.8-metre window streets, 18.0-metre local roadways, with 26.0-metre collector road connections to area road network
- The subdivision is considered to be designed for 30 km/h roadways
- The conceptual traffic calming elements are recommended at the future internal road intersections including intersection narrowing, bulb-outs, and speed humps

Boundary Street Design

- The boundary streets will not meet pedestrian MMLOS target, significant speed reductions to meet a LOS target of A
- Old Montreal Road and Cox Country Road will not meet bicycle MMLOS targets and require cycling facilities and speed reductions to meet the targets
- Once Old Montreal Road is widened, it is expected to meet the bicycle MMLOS targets

Access Intersections Design

- The residential accesses will connect via two new collector roads each to Old Montreal Road and Cox Country Road
- The site accesses will have stop-control on the minor approach as confirmed by a signal warrant
- As part of the work supporting Phase 4 of the Cardinal Creek Village north of Old Montreal Road, the eastbound left-turn lane is subject to a monitoring exercise for meeting warrants
- An auxiliary eastbound right-turn lane is recommended to be added to the scope of the RMA works pending for the intersection of Cardinal Creek Drive/Street No.1 at Old Montreal Road as part of the monitoring program, and this lane has been assumed within future total conditions
- The recommended storage lengths at the intersection of Cardinal Creek Drive/Street No.1 at Old Montreal Road are 70 metres for the eastbound right-turn lane, and the minimum 37.5 metres for the westbound left-turn lane
- Within the subdivision, no turn lanes are proposed for the internal intersections which will be controlled by minor stop control
- The 2027 and 2032 future total access intersections operate satisfactorily

TDM

- Supportive TDM measures to be included within the proposed development should include:
 - Inclusion of a 1-year Presto card for first time new townhome purchase, with a set time frame for this offer (e.g. 6-months) from the initial opening of the site
 - Contract with OC Transpo to provide early transit services until regular services are warranted by occupancy levels
 - Provide a multimodal travel option information package to new residents

NTM

- The volumes accessing Cox Country Road are below the threshold of 2,500 vehicles per day or 300 vehicles during the peak hour, and thus no further discussion is required

Transit

- 147 outbound AM trips and 105 inbound PM trips are anticipated from the development
- Existing bus service in the area is reflective of the state of build-out of the developing community. It is anticipated that bus service will increase as the ridership base increases in the area
- To meet forecasted transit use, approximately three to four single capacity buses would be required for peak hour service on local routes
- No significant impacts are noted to the traffic movements that currently support transit movements in the study area

Network Concept

- No changes to the network concept are required to support this project

Network Intersection Design

- Generally, the network intersections operating at the future total horizons will operate similarly to the future background conditions

- During PM peak hour, the southbound movement at the roundabout of Trim Road and Old Montreal Road/St. Joseph Boulevard is expected to experience high delays in the 2032 future total horizon, which is similar to the background conditions
- During the PM peak hour, the northbound movement and southbound shared left-turn/through movement at Old Montreal Road and Aveia Private/Dairy Drive intersection is expected to experience high delays in the 2032 future total horizon
- As a roundabout intersection, limited opportunity exists to change the intersection configuration and any operational improvements will need to be a result of network volume reductions within Orleans

17 Conclusion

It is recommended that, from a transportation perspective, the proposed development applications proceed.

Prepared By:



John Kingsley,
Transportation Engineering-Intern

Reviewed By:



Christopher Gordon, P.Eng.
Senior Transportation Engineer

Appendix A

TIA Screening Form and PM Certification Form

City of Ottawa 2017 TIA Guidelines
Step 1 - Screening Form

Date: 16-Nov-21
Project Number: 2019-68
Project Reference: CCV South Phase

1.1 Description of Proposed Development	
Municipal Address	1296 & 1400 Old Montreal Road
Description of Location	Ward 19, southwest corner of the Old Montreal Road and Cox Country Road intersection
Land Use Classification	Rural Countryside (RU), Rural Institutional Zone (RI5), Parks and Open Space Zone (O1), Arterial Mainstreet Zone (AM)
Development Size	168 gallery townhome units, 286 townhome units, and 304 single detached units
Accesses	One access to Old Montreal Road and one access to Cox Country Road
Phase of Development	Five Phases
Buildout Year	2027
TIA Requirement	Full TIA Required

1.2 Trip Generation Trigger		
Land Use Type	Townhomes or apartments	
Development Size	758	Units
Trip Generation Trigger	Yes	

1.3 Location Triggers	
Does the development propose a new driveway to a boundary street that is designated as part of the City's Transit Priority, Rapid Transit or Spine Bicycle Networks?	Yes
Is the development in a Design Priority Area (DPA) or Transit-oriented Development (TOD) zone?	Yes
Location Trigger	Yes

1.4. Safety Triggers	
Are posted speed limits on a boundary street 80 km/hr or greater?	Yes
Are there any horizontal/vertical curvatures on a boundary street limits sight lines at a proposed driveway?	No
Is the proposed driveway within the area of influence of an adjacent traffic signal or roundabout (i.e. within 300 m of intersection in rural conditions, or within 150 m of intersection in urban/ suburban conditions)?	No
Is the proposed driveway within auxiliary lanes of an intersection?	No
Does the proposed driveway make use of an existing median break that serves an existing site?	No
Is there is a documented history of traffic operations or safety concerns on the boundary streets within 500 m of the development?	No
Does the development include a drive-thru facility?	No
Safety Trigger	Yes

Appendix B

TIA First Submission Comments

5. Transportation

Mike Giampa | Senior Engineer, Infrastructure Applications | mike.giampa@ottawa.ca

List of Plan(s) and Drawing(s) Reviewed

Draft Transportation Impact Assessment, prepared by CGH Transportation, dated December 2021

Draft Plan of Subdivision of Part of Lots 25, 26, and 27 Concession 1 (Old Survey), prepared by Annis, O'Sullivan, Vollebakk Ltd., no date

Geometric Road Design Concept Plan, Drawing Number 001, prepared by CGH Transportation, dated December 10, 2021

1. A final, detailed Geometric Road design will be required indicating pavement dimensions, road signage and pavement markings for the subdivision along with curb depressions and TWSIs. No additional vertical/horizontal measures are required but the locations must be finalized to ensure proper spacing and avoid conflicts.
2. As per the City's most recent local road cross sections- 18 metre right ways within the subdivision should have sidewalks on both sides- when feasible.
3. Refer to the *Official Plan* ([Schedule C16 – Road Classification and Rights-of-Way Protection](#)) for the ultimate right of way protection on Old Montreal Road.
4. The shoulder on Old Montreal Road along the site frontage should be widened to a minimum of 1.5 metres to accommodate cyclists and pedestrians. This 1.5 metres minimum paved shoulder also applies to Cox Country, though a higher order cycling facility is strongly recommended for a high-speed collector spine route.
5. Post 2031, it can be assumed that the intersection of Old Montreal Road and Cardinal Creek Drive/Street 1 will be signalized. Prior to the ultimate configuration, an eastbound right-turn lane should be explored as the right turning volume approaches 25% of the total eastbound traffic.

6. Noise

List of Plan(s) Reviewed

Roadway Traffic Noise Feasibility Assessment Cardinal Creek Village South, Report:21-428 – Traffic Noise, prepared by Gradient Wind Engineers and Scientists, dated January 4, 2022

1. Old Montreal Road should be modeled as a 4-lane arterial road as per the Transportation Master Plan's ultimate network concept

Appendix C

Turning Movement Counts



Transportation Services - Traffic Services

Turning Movement Count - Study Results

ST. JOSEPH BLVD/OLD MONTREAL RD @ TRIM RD

Survey Date: Wednesday, April 26, 2017

WO No: 36103

Start Time: 07:00

Device: Miovision

Full Study Diagram

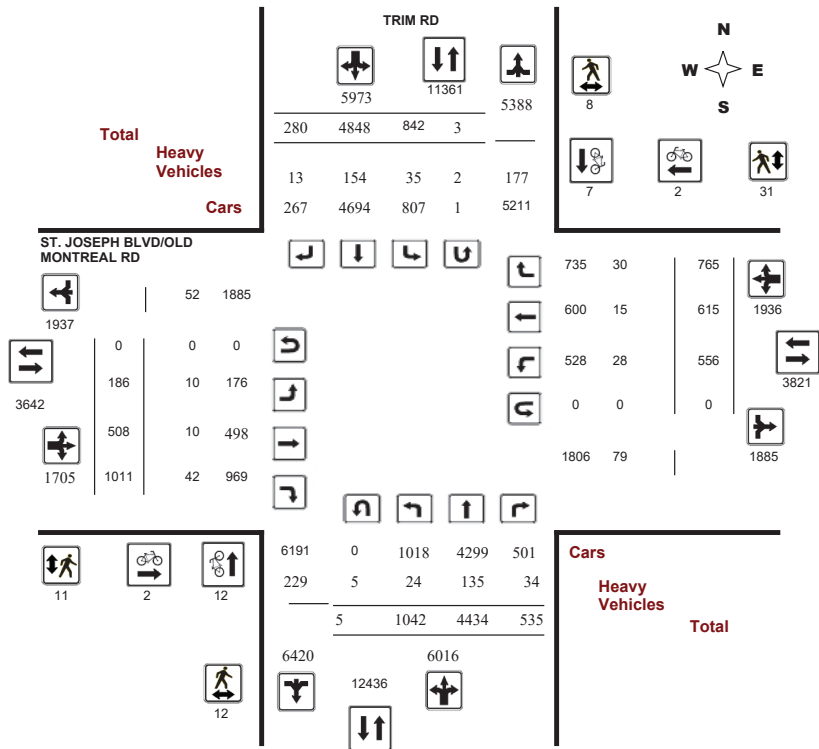

Transportation Services - Traffic Services

Turning Movement Count - Study Results

ST. JOSEPH BLVD/OLD MONTREAL RD @ TRIM RD

Survey Date: Wednesday, April 26, 2017

WO No: 36103

Start Time: 07:00

Device: Miovision

Full Study Peak Hour Diagram

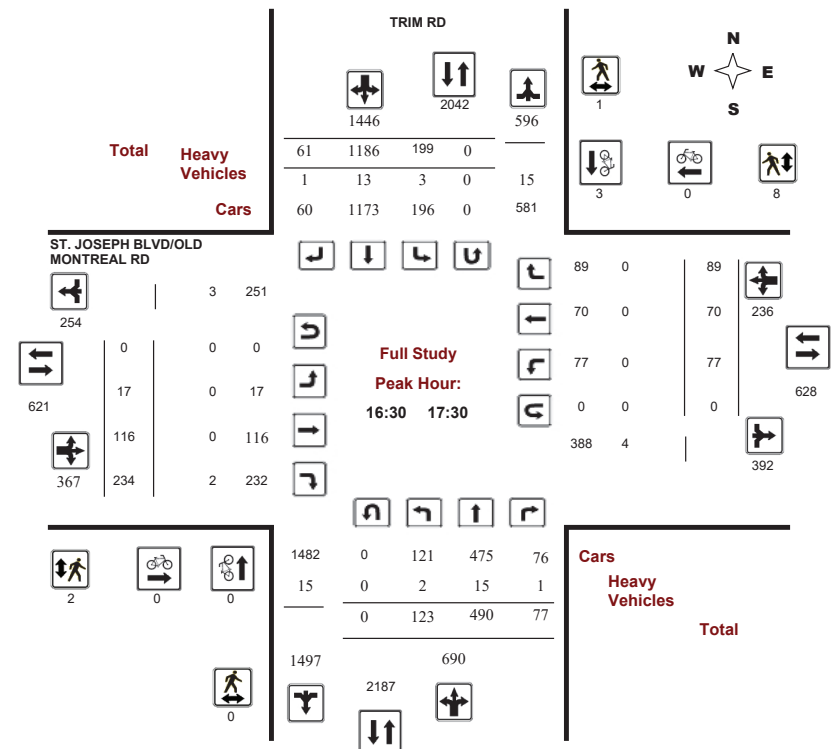



Transportation Services - Traffic Services

Turning Movement Count - Peak Hour Diagram

ST. JOSEPH BLVD/OLD MONTREAL RD @ TRIM RD

Survey Date: Wednesday, April 26, 2017
Start Time: 07:00

WO No: 36103
Device: Miovision

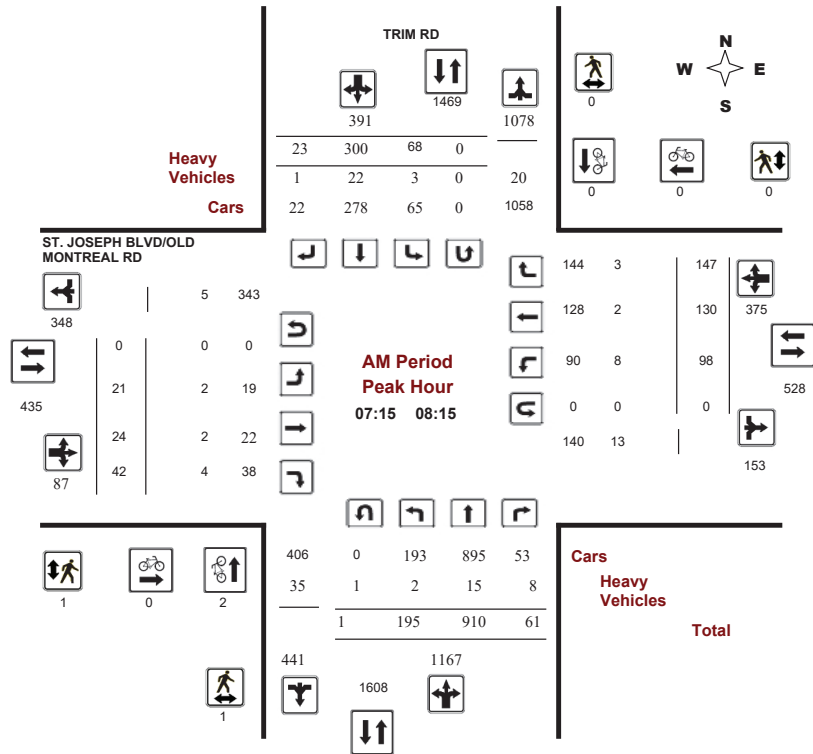

Comments



Transportation Services - Traffic Services

Turning Movement Count - Peak Hour Diagram

ST. JOSEPH BLVD/OLD MONTREAL RD @ TRIM RD

Survey Date: Wednesday, April 26, 2017
Start Time: 07:00

WO No: 36103
Device: Miovision

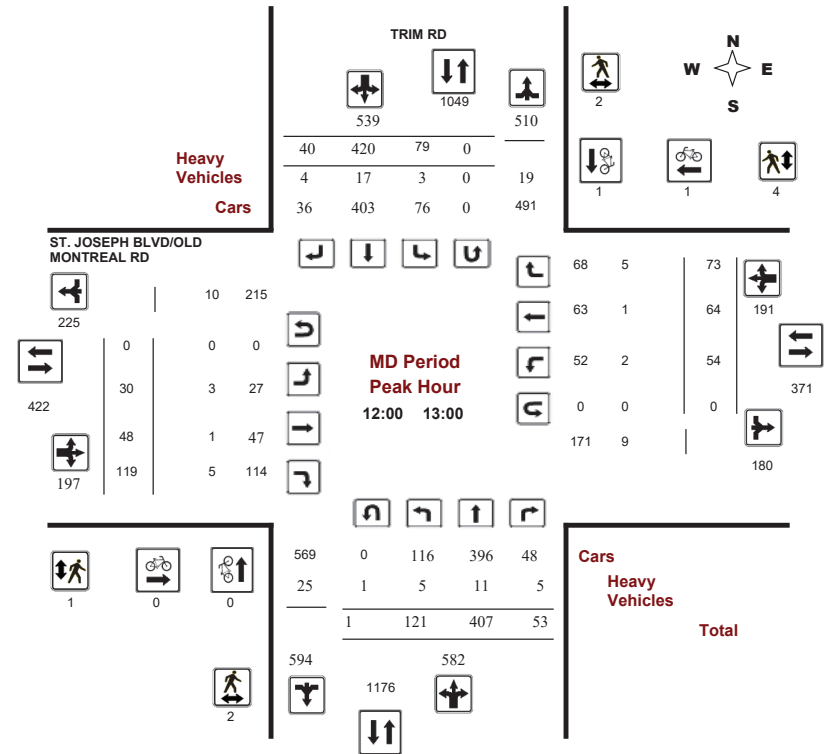

Comments



Transportation Services - Traffic Services

Turning Movement Count - Peak Hour Diagram

ST. JOSEPH BLVD/OLD MONTREAL RD @ TRIM RD

Survey Date: Wednesday, April 26, 2017
Start Time: 07:00

WO No: 36103
Device: Miovision

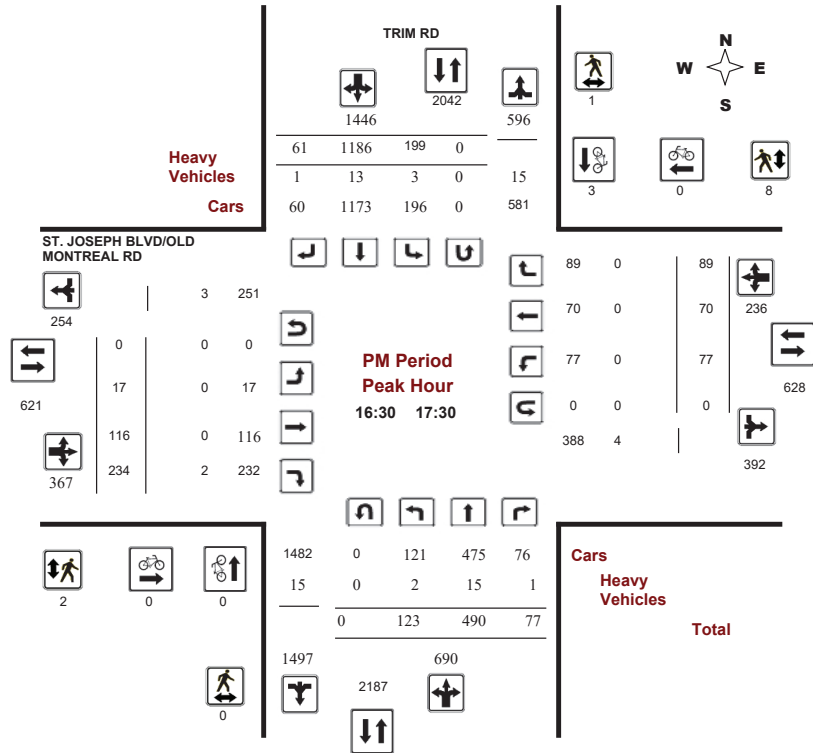

Comments



Transportation Services - Traffic Services

Turning Movement Count - Study Results

ST. JOSEPH BLVD/OLD MONTREAL RD @ TRIM RD

Survey Date: Wednesday, April 26, 2017
Start Time: 07:00

WO No: 36103
Device: Miovision

Full Study Summary (8 HR Standard)

Survey Date: Wednesday, April 26, 2017

Total Observed U-Turns **AADT Factor**

Northbound: 5	Southbound: 3	.90
Eastbound: 0	Westbound: 0	

Period	TRIM RD								ST. JOSEPH BLVD/OLD MONTREAL RD								Grand Total		
	Northbound				Southbound				Eastbound				Westbound						
	LT	ST	RT	TOT	LT	ST	RT	TOT	LT	ST	RT	TOT	LT	ST	RT	TOT			
07:00-08:00	173	923	46	1142	64	292	21	377	1519	28	14	42	84	90	151	158	399	483	2002
08:00-09:00	182	753	70	1005	54	300	33	387	1392	9	41	53	103	81	96	154	331	434	1826
09:00-10:00	125	535	45	705	56	290	28	374	1079	24	29	63	116	58	60	83	201	317	1396
11:30-12:30	115	429	44	588	77	368	33	478	1066	25	55	114	194	54	42	69	165	359	1425
12:30-13:30	112	392	61	565	94	430	41	565	1130	30	47	109	186	51	66	65	182	368	1498
15:00-16:00	93	417	92	602	131	909	34	1074	1676	26	89	163	278	72	69	85	226	504	2180
16:00-17:00	121	447	91	659	203	1098	43	1344	2003	24	117	236	377	81	64	81	226	603	2606
17:00-18:00	121	538	86	745	163	1161	47	1371	2116	20	116	231	367	69	67	70	206	573	2689
Sub Total	1042	4434	535	6011	842	4848	280	5970	11981	186	508	1011	1705	556	615	765	1936	3641	15622
U Turns	5			5	3			3	8	0			0	0			0	0	8
Total	1047	4434	535	6016	845	4848	280	5973	11989	186	508	1011	1705	556	615	765	1936	3641	15630
EQ 12Hr	1455	6163	744	8362	1175	6739	389	8303	16665	259	706	1405	2370	773	855	1063	2691	5061	21726
Note: These values are calculated by multiplying the totals by the appropriate expansion factor.																	1.39		
AVG 12Hr	1310	5547	670	7527	1058	6065	350	7473	15000	233	635	1264	2132	696	770	957	2423	4555	19555
Note: These volumes are calculated by multiplying the Equivalent 12 hr. totals by the AADT factor.																	.90		
AVG 24Hr	1716	7267	878	9861	1386	7945	458	9789	19650	305	832	1656	2793	912	1009	1254	3175	5968	25618
Note: These volumes are calculated by multiplying the Average Daily 12 hr. totals by 12 to 24 expansion factor.																	1.31		
Note: U-Turns provided for approach totals. Refer to 'U-Turn' Report for specific breakdown.																			



Transportation Services - Traffic Services

Turning Movement Count - Study Results

ST. JOSEPH BLVD/OLD MONTREAL RD @ TRIM RD

Survey Date: Wednesday, April 26, 2017

WO No: 36103

Start Time: 07:00

Device: Miovision

Full Study 15 Minute Increments

TRIM RD ST. JOSEPH BLVD/OLD MONTREAL RD

Table with columns for Time Period, Northbound, Southbound, Eastbound, Westbound, and Grand Total. Rows show 15-minute intervals from 07:00 to 18:00.

Note: U-Turns are included in Totals.



Transportation Services - Traffic Services

Turning Movement Count - Study Results

ST. JOSEPH BLVD/OLD MONTREAL RD @ TRIM RD

Survey Date: Wednesday, April 26, 2017

WO No: 36103

Start Time: 07:00

Device: Miovision

Full Study Cyclist Volume

TRIM RD ST. JOSEPH BLVD/OLD MONTREAL RD

Table with columns for Time Period, Northbound, Southbound, Street Total, Eastbound, Westbound, Street Total, and Grand Total. Rows show 15-minute intervals from 07:00 to 18:00.



Transportation Services - Traffic Services

Turning Movement Count - Study Results

ST. JOSEPH BLVD/OLD MONTREAL RD @ TRIM RD

Survey Date: Wednesday, April 26, 2017

WO No: 36103

Start Time: 07:00

Device: Miovision

Full Study Pedestrian Volume

TRIM RD ST. JOSEPH BLVD/OLD MONTREAL RD

Time Period	NB Approach (E or W Crossing)		Total	EB Approach (N or S Crossing)		Total	Grand Total
	SB Approach (E or W Crossing)	WB Approach (N or S Crossing)					
07:00 07:15	0	0	0	0	0	0	0
07:15 07:30	1	0	1	0	0	0	1
07:30 07:45	0	0	0	1	0	1	1
07:45 08:00	0	0	0	0	0	0	0
08:00 08:15	0	0	0	0	0	0	0
08:15 08:30	1	0	1	1	0	1	2
08:30 08:45	0	0	0	0	1	1	1
08:45 09:00	0	0	0	0	1	1	1
09:00 09:15	1	0	1	0	0	0	1
09:15 09:30	0	0	0	0	0	0	0
09:30 09:45	0	0	0	0	2	2	2
09:45 10:00	0	0	0	0	0	0	0
11:30 11:45	0	0	0	0	3	3	3
11:45 12:00	0	0	0	0	1	1	1
12:00 12:15	0	2	2	1	1	2	4
12:15 12:30	1	0	1	0	0	0	1
12:30 12:45	1	0	1	0	1	1	2
12:45 13:00	0	0	0	0	2	2	2
13:00 13:15	0	2	2	0	0	0	2
13:15 13:30	0	1	1	1	0	1	2
15:00 15:15	0	0	0	1	1	2	2
15:15 15:30	1	0	1	0	1	1	2
15:30 15:45	0	0	0	0	2	2	2
15:45 16:00	4	0	4	1	0	1	5
16:00 16:15	0	0	0	1	2	3	3
16:15 16:30	2	1	3	2	3	5	8
16:30 16:45	0	0	0	1	5	6	6
16:45 17:00	0	1	1	1	1	2	3
17:00 17:15	0	0	0	0	1	1	1
17:15 17:30	0	0	0	0	1	1	1
17:30 17:45	0	1	1	0	1	1	2
17:45 18:00	0	0	0	0	1	1	1
Total	12	8	20	11	31	42	62



Transportation Services - Traffic Services

Turning Movement Count - Study Results

ST. JOSEPH BLVD/OLD MONTREAL RD @ TRIM RD

Survey Date: Wednesday, April 26, 2017

WO No: 36103

Start Time: 07:00

Device: Miovision

Full Study Heavy Vehicles

TRIM RD ST. JOSEPH BLVD/OLD MONTREAL RD

Time Period	Northbound				Southbound				Eastbound				Westbound				Grand Total			
	LT		RT		LT		RT		LT		RT		LT		RT					
	N	TOT	N	TOT	S	TOT	S	TOT	E	TOT	E	TOT	W	TOT	W	TOT				
07:00 07:15	1	4	1	6	1	7	0	8	14	0	0	1	1	0	0	1	1	2	16	
07:15 07:30	1	2	5	8	0	4	0	4	12	0	1	1	2	2	0	1	3	5	17	
07:30 07:45	1	5	1	7	2	6	0	8	15	0	1	1	2	4	0	1	5	7	23	
07:45 08:00	0	2	0	2	1	8	1	10	12	1	0	2	3	0	0	1	1	4	16	
08:00 08:15	0	6	2	8	0	4	0	4	12	1	0	0	1	2	2	0	4	5	17	
08:15 08:30	2	3	1	6	2	5	2	9	15	0	0	1	1	3	0	1	4	5	20	
08:30 08:45	1	2	1	4	3	7	1	11	15	0	0	1	1	0	4	1	5	6	21	
08:45 09:00	1	4	2	7	2	5	1	8	15	1	0	2	3	1	1	2	4	7	23	
09:00 09:15	0	8	1	9	1	11	0	12	21	0	0	2	2	3	0	3	6	8	29	
09:15 09:30	1	5	1	7	2	8	1	11	18	2	1	0	3	0	0	1	1	4	22	
09:30 09:45	0	5	2	7	1	4	0	5	12	0	2	2	4	0	1	1	2	6	18	
09:45 10:00	1	4	2	7	0	5	0	5	12	1	1	1	3	2	0	0	2	5	18	
11:30 11:45	0	4	0	4	1	1	0	2	6	0	0	2	2	0	2	2	4	6	12	
11:45 12:00	1	3	0	4	3	1	0	4	8	0	0	1	1	1	1	0	2	3	11	
12:00 12:15	1	4	3	8	0	4	2	6	14	0	0	2	2	1	0	1	2	4	19	
12:15 12:30	1	4	0	5	2	5	2	9	14	0	0	0	1	1	1	1	3	3	17	
12:30 12:45	2	1	2	5	0	1	0	1	6	1	0	3	4	0	0	0	0	4	10	
12:45 13:00	1	2	0	3	1	7	0	8	11	2	1	0	3	0	0	3	3	6	17	
13:00 13:15	0	8	1	9	0	4	1	5	14	0	0	4	4	0	0	0	0	4	19	
13:15 13:30	1	0	1	2	1	4	0	5	7	1	1	0	2	2	0	2	4	6	13	
15:00 15:15	1	5	3	9	2	11	1	14	23	0	0	0	0	1	0	1	2	2	25	
15:15 15:30	1	4	1	6	0	6	0	6	12	0	0	4	4	1	2	4	7	11	23	
15:30 15:45	0	8	1	9	1	2	0	3	12	0	0	2	2	2	0	2	4	6	18	
15:45 16:00	4	6	0	10	3	7	0	10	20	0	0	1	1	0	0	0	0	1	22	
16:00 16:15	0	4	1	5	1	4	0	5	10	0	1	1	2	1	1	1	3	5	15	
16:15 16:30	0	5	0	5	1	6	0	7	12	0	1	4	5	1	0	0	1	6	19	
16:30 16:45	0	4	0	4	0	1	0	1	5	0	0	1	1	0	0	0	0	1	6	
16:45 17:00	0	3	1	4	1	5	1	7	11	0	0	0	0	0	0	0	0	0	11	
17:00 17:15	1	3	0	4	1	2	0	3	7	0	0	1	1	0	0	0	0	1	8	
17:15 17:30	1	5	0	6	1	5	0	6	12	0	0	0	0	0	0	0	0	0	12	
17:30 17:45	0	5	1	6	0	0	0	0	6	0	0	1	1	0	0	0	0	1	7	
17:45 18:00	0	7	0	7	1	4	0	5	12	0	0	1	1	0	0	0	0	1	13	
Total	None	24	135	34	193	35	154	13	202	395	10	10	42	62	28	15	30	73	135	537



Transportation Services - Traffic Services

Turning Movement Count - Study Results

ST. JOSEPH BLVD/OLD MONTREAL RD @ TRIM RD

Survey Date: Wednesday, April 26, 2017

WO No: 36103

Start Time: 07:00

Device: Miovision

Full Study 15 Minute U-Turn Total

Time Period	TRIM RD		ST. JOSEPH BLVD/OLD MONTREAL RD		Total
	Northbound U-Turn Total	Southbound U-Turn Total	Eastbound U-Turn Total	Westbound U-Turn Total	
07:00 - 07:15	0	1	0	0	1
07:15 - 07:30	0	0	0	0	0
07:30 - 07:45	1	0	0	0	1
07:45 - 08:00	0	0	0	0	0
08:00 - 08:15	0	0	0	0	0
08:15 - 08:30	0	0	0	0	0
08:30 - 08:45	0	0	0	0	0
08:45 - 09:00	0	1	0	0	1
09:00 - 09:15	0	0	0	0	0
09:15 - 09:30	0	0	0	0	0
09:30 - 09:45	0	0	0	0	0
09:45 - 10:00	1	0	0	0	1
11:30 - 11:45	0	0	0	0	0
11:45 - 12:00	0	0	0	0	0
12:00 - 12:15	1	0	0	0	1
12:15 - 12:30	0	0	0	0	0
12:30 - 12:45	0	0	0	0	0
12:45 - 13:00	0	0	0	0	0
13:00 - 13:15	0	1	0	0	1
13:15 - 13:30	0	0	0	0	0
15:00 - 15:15	0	0	0	0	0
15:15 - 15:30	0	0	0	0	0
15:30 - 15:45	0	0	0	0	0
15:45 - 16:00	1	0	0	0	1
16:00 - 16:15	0	0	0	0	0
16:15 - 16:30	1	0	0	0	1
16:30 - 16:45	0	0	0	0	0
16:45 - 17:00	0	0	0	0	0
17:00 - 17:15	0	0	0	0	0
17:15 - 17:30	0	0	0	0	0
17:30 - 17:45	0	0	0	0	0
17:45 - 18:00	0	0	0	0	0
Total	5	3	0	0	8



Transportation Services - Traffic Services

Turning Movement Count - Study Results

AVEIA PRIV/DAIRY DR @ OLD MONTREAL RD

Survey Date: Wednesday, December 04, 2019

WO No: 39171

Start Time: 07:00

Device: Miovision

Full Study Diagram

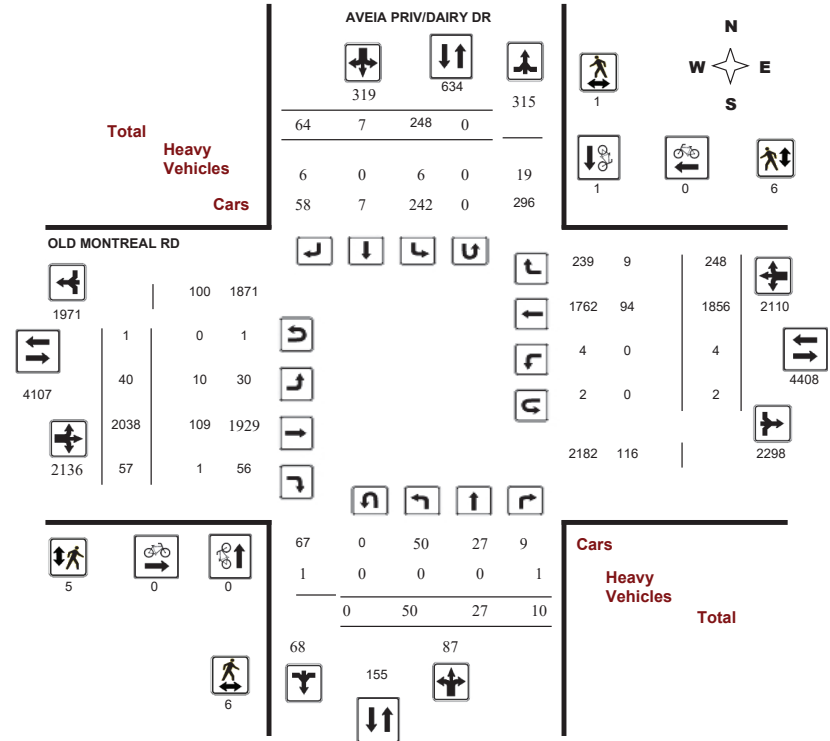



Transportation Services - Traffic Services

Turning Movement Count - Study Results

AVEIA PRIV/DAIRY DR @ OLD MONTREAL RD

Survey Date: Wednesday, December 04, 2019

WO No: 39171

Start Time: 07:00

Device: Miovision

Full Study Peak Hour Diagram

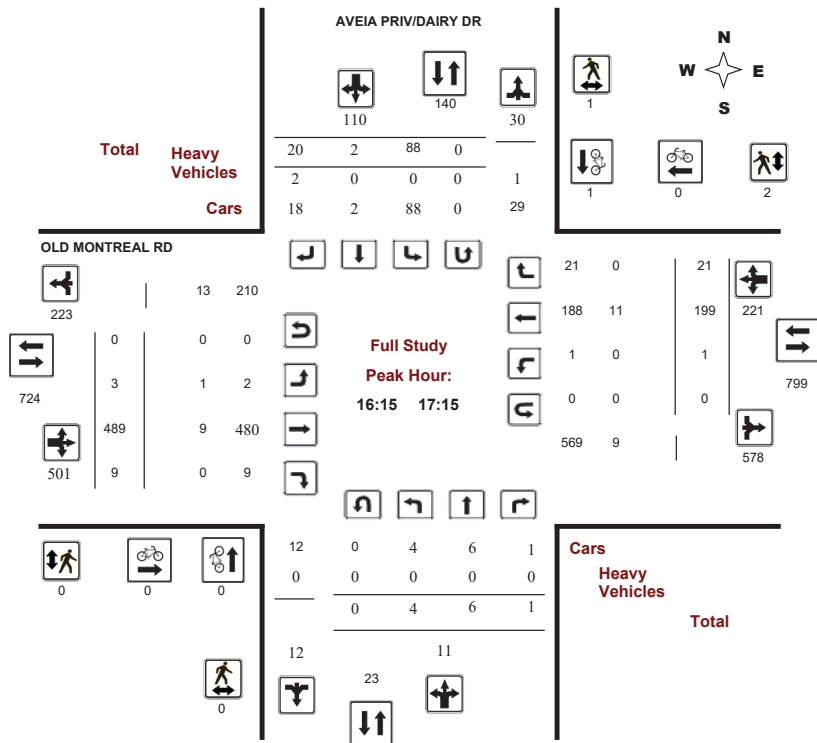

Transportation Services - Traffic Services

Turning Movement Count - Peak Hour Diagram

AVEIA PRIV/DAIRY DR @ OLD MONTREAL RD

Survey Date: Wednesday, December 04, 2019

WO No: 39171

Start Time: 07:00

Device: Miovision

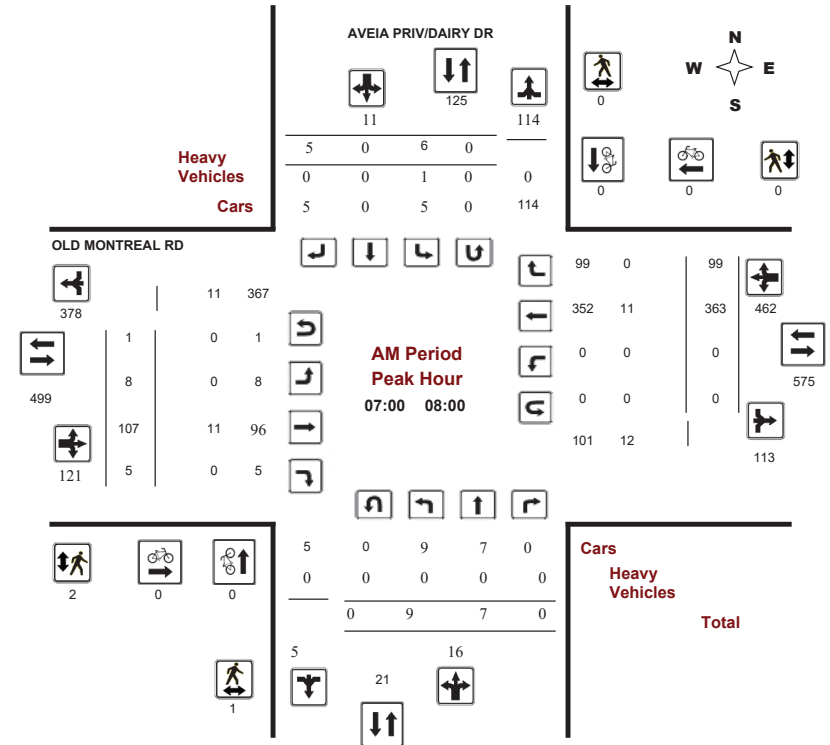

Comments



Transportation Services - Traffic Services

Turning Movement Count - Peak Hour Diagram

AVEIA PRIV/DAIRY DR @ OLD MONTREAL RD

Survey Date: Wednesday, December 04, 2019

Start Time: 07:00

WO No: 39171

Device: Miovision

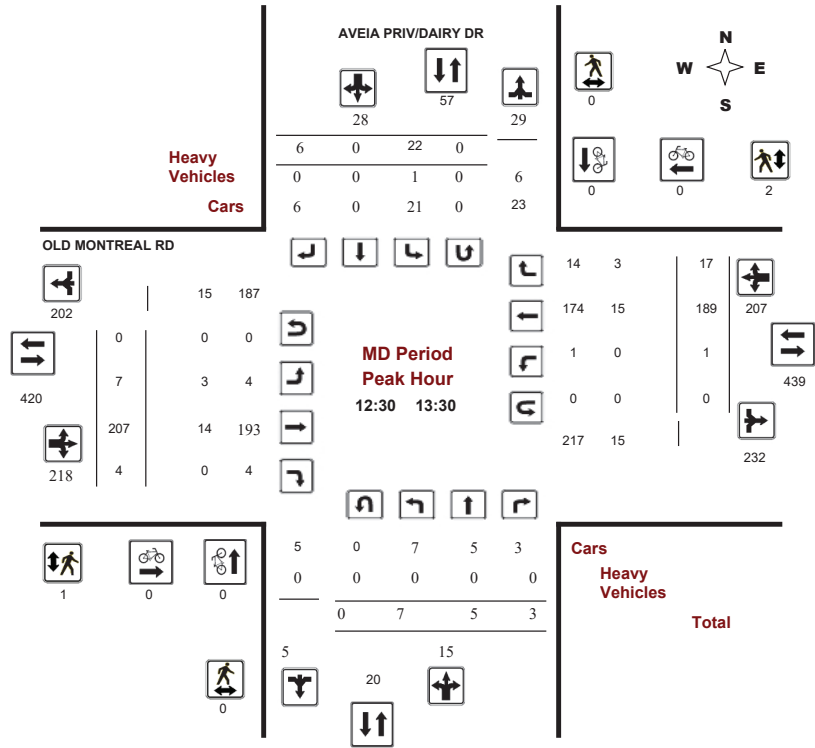

Comments



Transportation Services - Traffic Services

Turning Movement Count - Peak Hour Diagram

AVEIA PRIV/DAIRY DR @ OLD MONTREAL RD

Survey Date: Wednesday, December 04, 2019

Start Time: 07:00

WO No: 39171

Device: Miovision

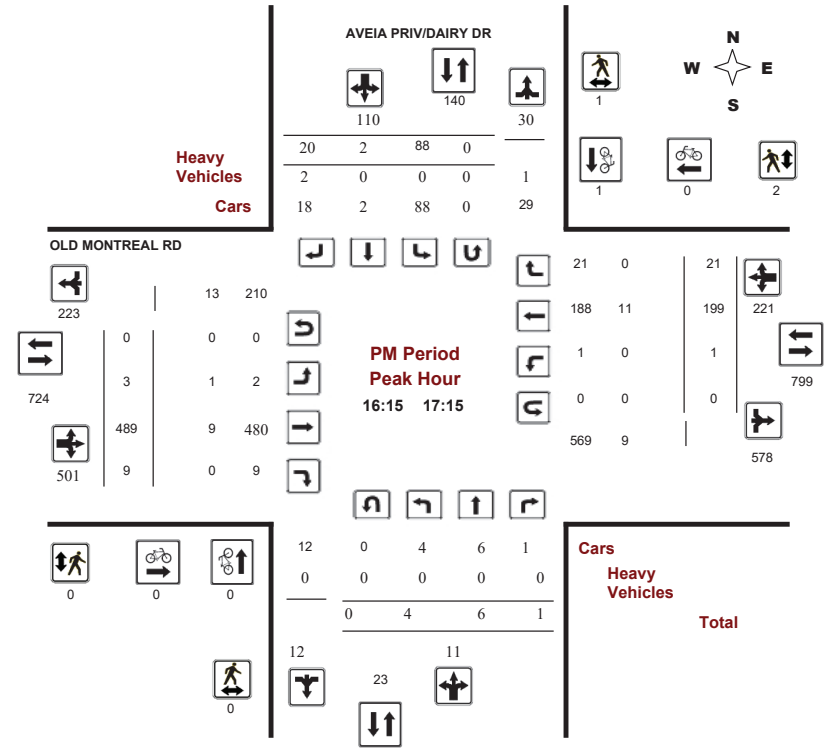

Comments



Transportation Services - Traffic Services

Turning Movement Count - Study Results

AVEIA PRIV/DAIRY DR @ OLD MONTREAL RD

Survey Date: Wednesday, December 04, 2019

WO No: 39171

Start Time: 07:00

Device: Miovision

Full Study Summary (8 HR Standard)

Survey Date: Wednesday, December 04, 2019

Total Observed U-Turns AADT Factor
Northbound: 0 Southbound: 0 Eastbound: 1 Westbound: 2 1.00

Table with columns for Period, Northbound, Southbound, Eastbound, Westbound, and Grand Total. Includes sub-totals for U Turns, EQ 12Hr, and AVG 24Hr.



Transportation Services - Traffic Services

Turning Movement Count - Study Results

AVEIA PRIV/DAIRY DR @ OLD MONTREAL RD

Survey Date: Wednesday, December 04, 2019

WO No: 39171

Start Time: 07:00

Device: Miovision

Full Study 15 Minute Increments

Table with columns for Time Period, Northbound, Southbound, Eastbound, Westbound, and Grand Total. Shows 15-minute increments from 07:00 to 18:00.

Note: U-Turns are included in Totals.



Transportation Services - Traffic Services

Turning Movement Count - Study Results

AVEIA PRIV/DAIRY DR @ OLD MONTREAL RD

Survey Date: Wednesday, December 04, 2019

WO No: 39171

Start Time: 07:00

Device: Miovision

Full Study Cyclist Volume

Time Period	AVEIA PRIV/DAIRY DR			OLD MONTREAL RD			Grand Total
	Northbound	Southbound	Street Total	Eastbound	Westbound	Street Total	
07:00 07:15	0	0	0	0	0	0	0
07:15 07:30	0	0	0	0	0	0	0
07:30 07:45	0	0	0	0	0	0	0
07:45 08:00	0	0	0	0	0	0	0
08:00 08:15	0	0	0	0	0	0	0
08:15 08:30	0	0	0	0	0	0	0
08:30 08:45	0	0	0	0	0	0	0
08:45 09:00	0	0	0	0	0	0	0
09:00 09:15	0	0	0	0	0	0	0
09:15 09:30	0	0	0	0	0	0	0
09:30 09:45	0	0	0	0	0	0	0
09:45 10:00	0	0	0	0	0	0	0
11:30 11:45	0	0	0	0	0	0	0
11:45 12:00	0	0	0	0	0	0	0
12:00 12:15	0	0	0	0	0	0	0
12:15 12:30	0	0	0	0	0	0	0
12:30 12:45	0	0	0	0	0	0	0
12:45 13:00	0	0	0	0	0	0	0
13:00 13:15	0	0	0	0	0	0	0
13:15 13:30	0	0	0	0	0	0	0
15:00 15:15	0	0	0	0	0	0	0
15:15 15:30	0	0	0	0	0	0	0
15:30 15:45	0	0	0	0	0	0	0
15:45 16:00	0	0	0	0	0	0	0
16:00 16:15	0	0	0	0	0	0	0
16:15 16:30	0	0	0	0	0	0	0
16:30 16:45	0	1	1	0	0	0	1
16:45 17:00	0	0	0	0	0	0	0
17:00 17:15	0	0	0	0	0	0	0
17:15 17:30	0	0	0	0	0	0	0
17:30 17:45	0	0	0	0	0	0	0
17:45 18:00	0	0	0	0	0	0	0
Total	0	1	1	0	0	0	1



Transportation Services - Traffic Services

Turning Movement Count - Study Results

AVEIA PRIV/DAIRY DR @ OLD MONTREAL RD

Survey Date: Wednesday, December 04, 2019

WO No: 39171

Start Time: 07:00

Device: Miovision

Full Study Pedestrian Volume

Time Period	AVEIA PRIV/DAIRY DR			OLD MONTREAL RD			Grand Total
	NB Approach (E or W Crossing)	SB Approach (E or W Crossing)	Total	EB Approach (N or S Crossing)	WB Approach (N or S Crossing)	Total	
07:00 07:15	0	0	0	1	0	1	1
07:15 07:30	0	0	0	0	0	0	0
07:30 07:45	1	0	1	1	0	1	2
07:45 08:00	0	0	0	0	0	0	0
08:00 08:15	0	0	0	1	0	1	1
08:15 08:30	0	0	0	0	0	0	0
08:30 08:45	0	0	0	1	0	1	1
08:45 09:00	0	0	0	0	0	0	0
09:00 09:15	0	0	0	0	0	0	0
09:15 09:30	0	0	0	0	0	0	0
09:30 09:45	0	0	0	0	0	0	0
09:45 10:00	0	0	0	0	0	0	0
11:30 11:45	0	0	0	0	0	0	0
11:45 12:00	0	0	0	0	0	0	0
12:00 12:15	1	0	1	0	0	0	1
12:15 12:30	0	0	0	0	0	0	0
12:30 12:45	0	0	0	0	0	0	0
12:45 13:00	0	0	0	0	0	0	0
13:00 13:15	0	0	0	1	2	3	3
13:15 13:30	0	0	0	0	0	0	0
15:00 15:15	1	0	1	0	0	0	1
15:15 15:30	2	0	2	0	1	1	3
15:30 15:45	0	0	0	0	0	0	0
15:45 16:00	0	0	0	1	0	1	1
16:00 16:15	1	0	1	0	0	0	1
16:15 16:30	0	1	1	0	0	0	1
16:30 16:45	0	0	0	0	0	0	0
16:45 17:00	0	0	0	2	0	2	2
17:00 17:15	0	0	0	0	0	0	0
17:15 17:30	0	0	0	0	0	0	0
17:30 17:45	0	0	0	0	0	0	0
17:45 18:00	0	0	0	0	0	0	0
Total	6	1	7	5	6	11	18



Transportation Services - Traffic Services

Turning Movement Count - Study Results

AVEIA PRIV/DAIRY DR @ OLD MONTREAL RD

Survey Date: Wednesday, December 04, 2019

WO No: 39171

Start Time: 07:00

Device: Miovision

Full Study Heavy Vehicles

Table with columns for Time Period, Northbound (LT, ST, RT, N TOT, STR TOT), Southbound (LT, ST, RT, S TOT, STR TOT), Eastbound (LT, ST, RT, E TOT), Westbound (LT, ST, RT, W TOT, STR TOT), and Grand Total. Rows show 15-minute intervals from 07:00 to 18:00.



Transportation Services - Traffic Services

Turning Movement Count - Study Results

AVEIA PRIV/DAIRY DR @ OLD MONTREAL RD

Survey Date: Wednesday, December 04, 2019

WO No: 39171

Start Time: 07:00

Device: Miovision

Full Study 15 Minute U-Turn Total

Table with columns for Time Period, Northbound U-Turn Total, Southbound U-Turn Total, Eastbound U-Turn Total, Westbound U-Turn Total, and Total. Rows show 15-minute intervals from 07:00 to 18:00.



Turning Movement Count Summary, AM and PM Peak Hour Flow Diagrams

Automobiles, Taxis, Light Trucks, Vans, SUVs, Motorcycles, Heavy Trucks, Buses, and School Buses

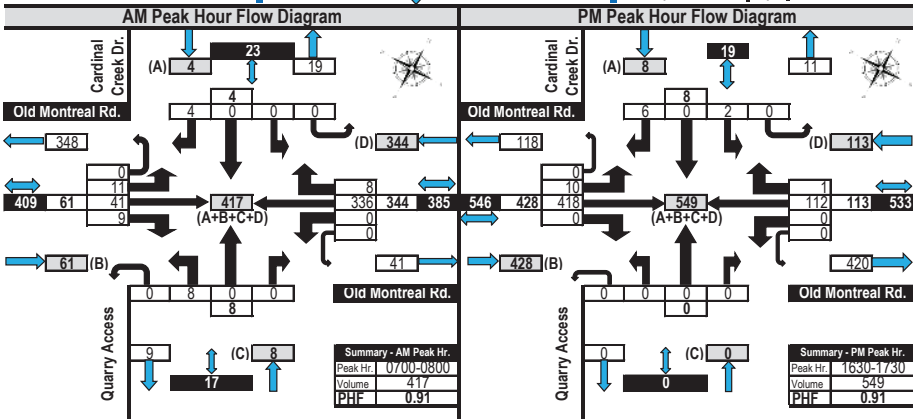
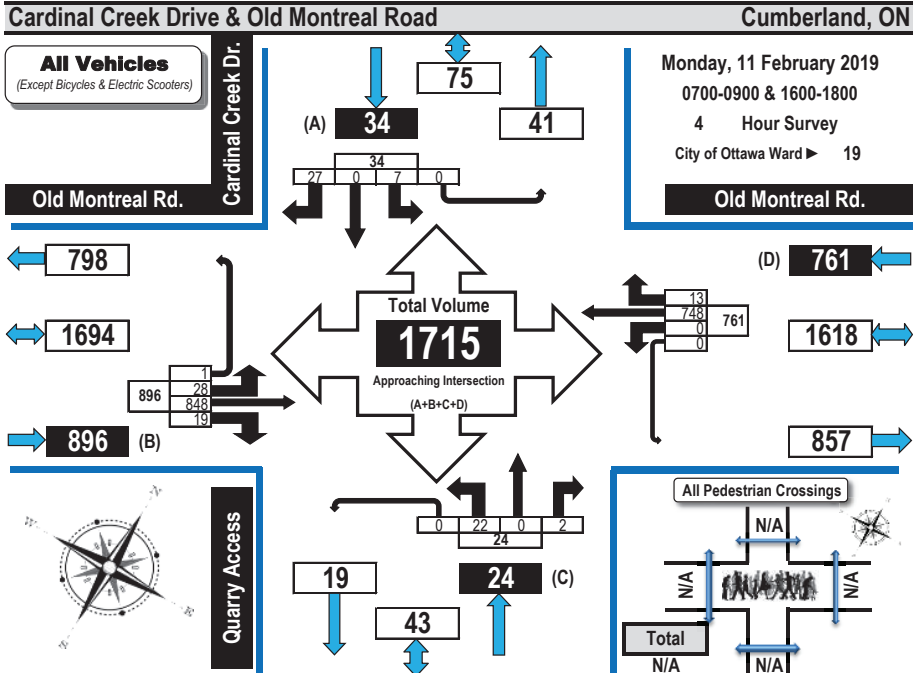

Turning Movement Count Heavy Vehicle Summary Flow Diagram

Heavy Trucks, Buses, and School Buses

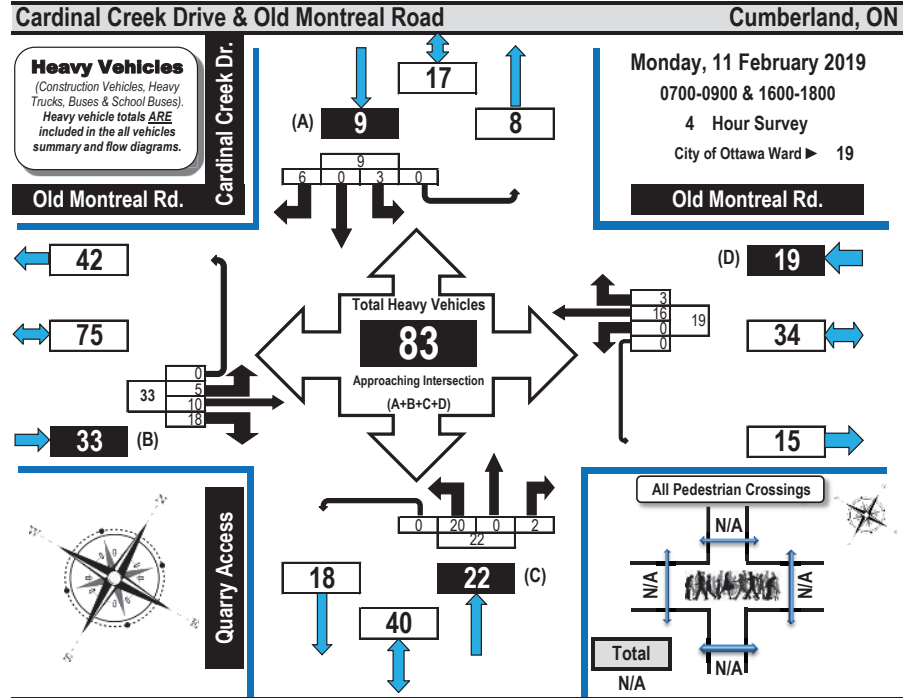

Time Period	Old Montreal Rd. Eastbound					Old Montreal Rd. Westbound					Quarry Access Northbound					Cardinal Creek Dr. Southbound					S. Tot	G. Tot
	LT	ST	RT	UT	S. Tot	LT	ST	RT	UT	S. Tot	LT	ST	RT	UT	S. Tot	LT	ST	RT	UT	S. Tot		
0700-0800	3	0	9	0	12	0	7	2	0	9	8	0	0	0	8	0	0	3	0	3	32	
0800-0900	1	0	9	0	10	0	4	1	0	5	11	0	0	0	11	1	0	2	0	3	29	
1600-1700	0	9	0	0	9	0	4	0	0	4	1	0	2	0	3	1	0	0	0	1	17	
1700-1800	1	1	0	0	2	0	1	0	0	1	0	0	0	0	0	1	0	1	0	2	5	
Totals	5	10	18	0	33	0	16	3	0	19	20	0	2	0	22	3	0	6	0	9	83	

Comments:

The quarry access, northbound, is offset approximately 10-15 m east of Cardinal Creek Drive. There are missing intersection warning signs (Wa-13), checkerboard sign southbound at Old Montreal Road (Wa-8LR) and keep right/object marker signs (Rb-25 & Wa-33L) on the median north of Old Montreal Road. The Cardinal Creek Village development is under construction and not fully occupied.



Turning Movement Count Summary Report AADT and Expansion Factors

Automobiles, Taxis,
Light Trucks, Vans,
SUV's, Motorcycles,
Heavy Trucks, Buses,
and School Buses

Cardinal Creek Drive & Old Montreal Road Cumberland, ON

Survey Date: Monday, 11 February 2019 Start Time: 0700 AADT Factor: 1.0
 Weather AM: Clear & Sunny -15°C Survey Duration: 4 Hrs. Survey Hours: 0700-0900 & 1600-1800
 Weather PM: Clear & Sunny -8°C Surveyor(s): Carmody

Time Period	Old Montreal Rd. Eastbound				Old Montreal Rd. Westbound				Quarry Access Northbound				Cardinal Creek Dr. Southbound				Street Total	Grand Total					
	LT	ST	RT	UT	LT	ST	RT	UT	LT	ST	RT	UT	LT	ST	RT	UT							
0700-0800	11	41	9	0	61	0	336	8	0	344	405	8	0	0	0	8	0	0	4	0	4	12	417
0800-0900	2	46	10	0	58	0	204	1	0	205	263	12	0	0	0	12	3	0	10	0	13	25	288
1600-1700	7	425	0	1	433	0	97	2	0	99	532	2	0	2	0	4	2	0	7	0	9	13	545
1700-1800	8	336	0	0	344	0	111	2	0	113	457	0	0	0	0	0	2	0	6	0	8	8	465
Totals	28	848	19	1	896	0	748	13	0	761	1657	22	0	2	0	24	7	0	27	0	34	58	1715

**Equivalent 12 & 24-hour Vehicle Volumes Including the Annual Average Daily Traffic (AADT) Factor
Applicable to the Day and Month of the Turning Movement Count**

Expansion factors are applied exclusively to standard weekday 8-hour turning movement counts conducted during the hours of 0700h - 1000h, 1130h - 1330h and 1500h - 1800h

Equivalent 12-hour vehicle volumes. These volumes are calculated by multiplying the 8-hour totals by the 8 → 12 expansion factor of 1.39

Equ. 12 Hr	n/a	n/a	n/a	n/a	n/a	n/a	n/a	n/a	n/a	n/a	n/a	n/a	n/a	n/a	n/a	n/a	n/a	n/a	n/a	n/a	n/a	n/a	n/a
------------	-----	-----	-----	-----	-----	-----	-----	-----	-----	-----	-----	-----	-----	-----	-----	-----	-----	-----	-----	-----	-----	-----	-----

Average daily 12-hour vehicle volumes. These volumes are calculated by multiplying the equivalent 12-hour totals by the AADT factor of: 1.0

AADT 12-hr	n/a	n/a	n/a	n/a	n/a	n/a	n/a	n/a	n/a	n/a	n/a	n/a	n/a	n/a	n/a	n/a	n/a	n/a	n/a	n/a	n/a	n/a	n/a
------------	-----	-----	-----	-----	-----	-----	-----	-----	-----	-----	-----	-----	-----	-----	-----	-----	-----	-----	-----	-----	-----	-----	-----

24-Hour AADT. These volumes are calculated by multiplying the average daily 12-hour vehicle volumes by the 12 → 24 expansion factor of 1.31

AADT 24 Hr	n/a	n/a	n/a	n/a	n/a	n/a	n/a	n/a	n/a	n/a	n/a	n/a	n/a	n/a	n/a	n/a	n/a	n/a	n/a	n/a	n/a	n/a	n/a
------------	-----	-----	-----	-----	-----	-----	-----	-----	-----	-----	-----	-----	-----	-----	-----	-----	-----	-----	-----	-----	-----	-----	-----

AADT and expansion factors provided by the City of Ottawa

AM Peak Hour Factor → 0.91													Highest Hourly Vehicle Volume Between 0700h & 0900h												
AM Peak Hr	LT	ST	RT	UT	TOT	LT	ST	RT	UT	TOT	S.TOT	LT	ST	RT	UT	TOT	LT	ST	RT	UT	TOT	S.TOT	G.TOT		
0700-0800	11	41	9	0	61	0	336	8	0	344	405	8	0	0	0	8	0	0	4	0	4	12	417		

PM Peak Hour Factor → 0.91													Highest Hourly Vehicle Volume Between 1600h & 1800h												
PM Peak Hr	LT	ST	RT	UT	TOT	LT	ST	RT	UT	TOT	S.TOT	LT	ST	RT	UT	TOT	LT	ST	RT	UT	TOT	S.TOT	G.TOT		
1630-1730	10	418	0	0	428	0	112	1	0	113	541	0	0	0	0	0	2	0	6	0	8	8	549		

Comments:

The quarry access, northbound, is offset approximately 10 - 15 m east of Cardinal Creek Drive. There are missing intersection warning signs (Wa-13), checkerboard sign southbound at Old Montreal Road (Wa-8LR) and keep right/object marker signs (Rb-25 & Wa-33L) on the median north of Old Montreal Road. The Cardinal Creek Village development is under construction and not fully occupied.

Notes:

1. Includes all vehicle types except bicycles, electric bicycles, and electric scooters.
2. When expansion and AADT factors are applied, the results will differ slightly due to rounding.



Transportation Services - Traffic Services

Turning Movement Count - Study Results

FRANK KENNY RD/TED KELLY LANE @ OLD MONTREAL R

Survey Date: Wednesday, August 28, 2019
Start Time: 07:00

WO No: 38746
Device: Miovision

Full Study Diagram

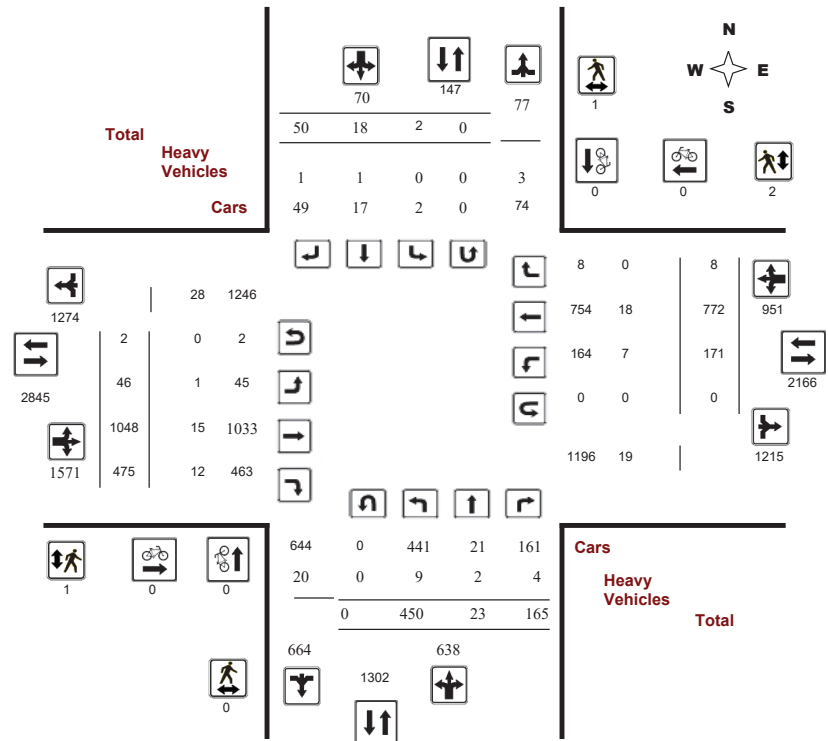



Transportation Services - Traffic Services

Turning Movement Count - Study Results

FRANK KENNY RD/TED KELLY LANE @ OLD MONTREAL R

Survey Date: Wednesday, August 28, 2019

WO No: 38746

Start Time: 07:00

Device: Miovision

Full Study Peak Hour Diagram

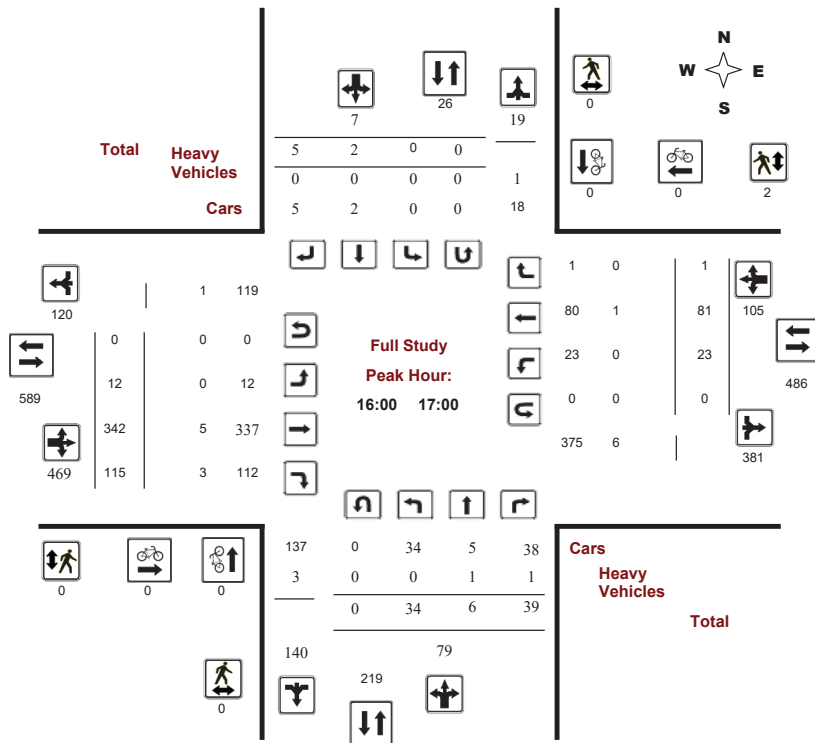

Transportation Services - Traffic Services

Turning Movement Count - Peak Hour Diagram

FRANK KENNY RD/TED KELLY LANE @ OLD MONTREAL R

Survey Date: Wednesday, August 28, 2019

WO No: 38746

Start Time: 07:00

Device: Miovision

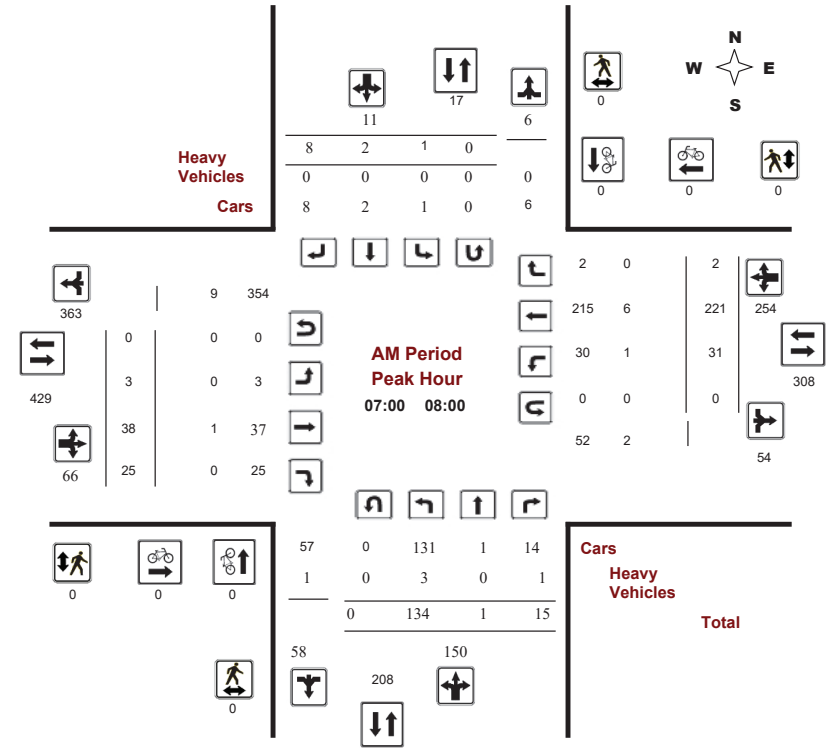

Comments



Transportation Services - Traffic Services

Turning Movement Count - Peak Hour Diagram

FRANK KENNY RD/TED KELLY LANE @ OLD MONTREAL R

Survey Date: Wednesday, August 28, 2019

Start Time: 07:00

WO No: 38746

Device: Miovision

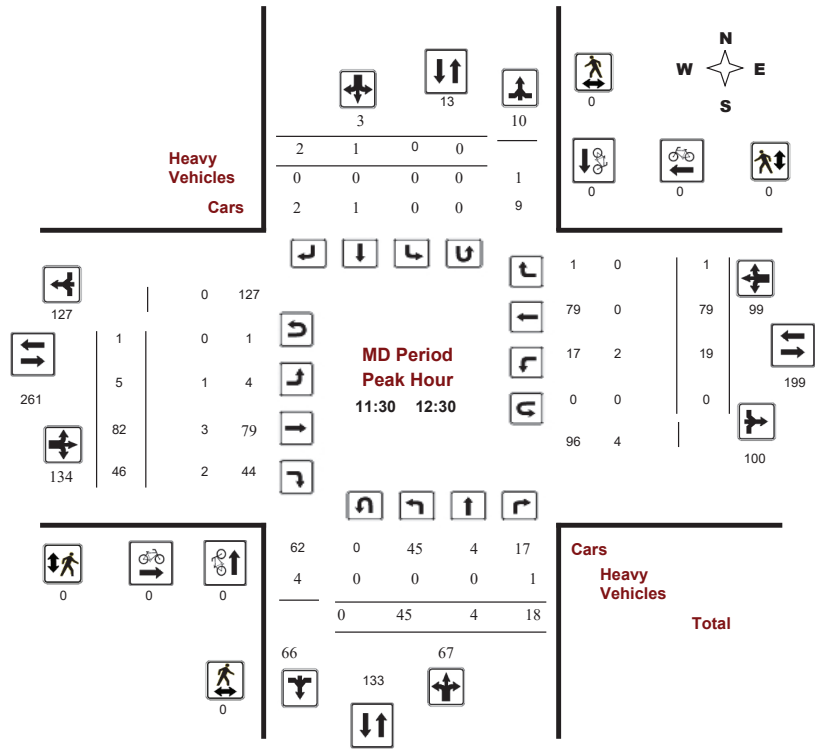

Comments



Transportation Services - Traffic Services

Turning Movement Count - Peak Hour Diagram

FRANK KENNY RD/TED KELLY LANE @ OLD MONTREAL R

Survey Date: Wednesday, August 28, 2019

Start Time: 07:00

WO No: 38746

Device: Miovision

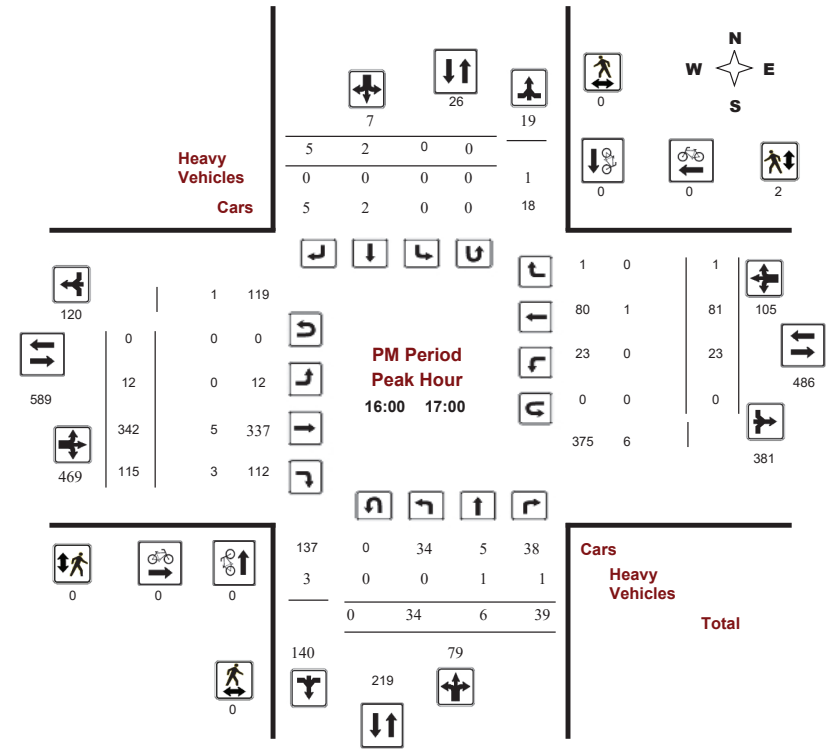

Comments



Transportation Services - Traffic Services

Turning Movement Count - Study Results

FRANK KENNY RD/TED KELLY LANE @ OLD MONTREAL R

Survey Date: Wednesday, August 28, 2019

WO No: 38746

Start Time: 07:00

Device: Miovision

Full Study Summary (8 HR Standard)

Survey Date: Wednesday, August 28, 2019

Total Observed U-Turns

ADT Factor

Northbound: 0 Southbound: 0
Eastbound: 2 Westbound: 0

Table with columns for Period, Northbound (LT, ST, RT, NB TOT), Southbound (LT, ST, RT, SB TOT), Eastbound (LT, ST, RT, EB TOT), Westbound (LT, ST, RT, WB TOT), STR TOT, Grand Total.

Note: These values are calculated by multiplying the totals by the appropriate expansion factor. 1.39

AVG 12Hr 563 29 206 798 3 22 63 88 886 60 1311 594 1965 214 966 10 1190 3155 4041
Note: These volumes are calculated by multiplying the Equivalent 12 hr. totals by the ADT factor. .90

AVG 24Hr 738 38 270 1046 4 29 83 116 1162 79 1717 778 2574 280 1265 13 1558 4132 5294
Note: These volumes are calculated by multiplying the Average Daily 12 hr. totals by 12 to 24 expansion factor. 1.31

Note: U-Turns provided for approach totals. Refer to 'U-Turn' Report for specific breakdown.



Transportation Services - Traffic Services

Turning Movement Count - Study Results

FRANK KENNY RD/TED KELLY LANE @ OLD MONTREAL R

Survey Date: Wednesday, August 28, 2019

WO No: 38746

Start Time: 07:00

Device: Miovision

Full Study 15 Minute Increments

Table with columns for Time Period, Northbound (LT, ST, RT, N TOT), Southbound (LT, ST, RT, S TOT), Eastbound (LT, ST, RT, E TOT), Westbound (LT, ST, RT, W TOT), STR TOT, Grand Total.

Note: U-Turns are included in Totals.



Transportation Services - Traffic Services

Turning Movement Count - Study Results

FRANK KENNY RD/TED KELLY LANE @ OLD MONTREAL R

Survey Date: Wednesday, August 28, 2019

WO No: 38746

Start Time: 07:00

Device: Miovision

Full Study Cyclist Volume

Table with 8 columns: Time Period, Northbound, Southbound, Street Total, Eastbound, Westbound, Street Total, Grand Total. Rows show cyclist volume data for various time intervals from 07:00 to 18:00.



Transportation Services - Traffic Services

Turning Movement Count - Study Results

FRANK KENNY RD/TED KELLY LANE @ OLD MONTREAL R

Survey Date: Wednesday, August 28, 2019

WO No: 38746

Start Time: 07:00

Device: Miovision

Full Study Pedestrian Volume

Table with 8 columns: Time Period, NB Approach (E or W Crossing), SB Approach (E or W Crossing), Total, EB Approach (N or S Crossing), WB Approach (N or S Crossing), Total, Grand Total. Rows show pedestrian volume data for various time intervals from 07:00 to 18:00.



Transportation Services - Traffic Services

Turning Movement Count - Study Results

FRANK KENNY RD/TED KELLY LANE @ OLD MONTREAL R

Survey Date: Wednesday, August 28, 2019

WO No: 38746

Start Time: 07:00

Device: Miovision

Full Study Heavy Vehicles

Table with columns for Time Period, Northbound (LT, ST, RT, N TOT, STR TOT), Southbound (LT, ST, RT, S TOT, STR TOT), Eastbound (LT, ST, RT, E TOT), Westbound (LT, ST, RT, W TOT, STR TOT), and Grand Total. Rows represent 15-minute intervals from 07:00 to 18:00.



Transportation Services - Traffic Services

Turning Movement Count - Study Results

FRANK KENNY RD/TED KELLY LANE @ OLD MONTREAL R

Survey Date: Wednesday, August 28, 2019

WO No: 38746

Start Time: 07:00

Device: Miovision

Full Study 15 Minute U-Turn Total

Table with columns for Time Period, Northbound U-Turn Total, Southbound U-Turn Total, Eastbound U-Turn Total, Westbound U-Turn Total, and Total. Rows represent 15-minute intervals from 07:00 to 18:00.



Transportation Services - Traffic Services

Turning Movement Count - Peak Hour Diagram

FRANK KENNY RD @ WILHAVEN DR

Survey Date: Wednesday, November 13, 2013
Start Time: 07:00

WO No: 924
Device: Miovision

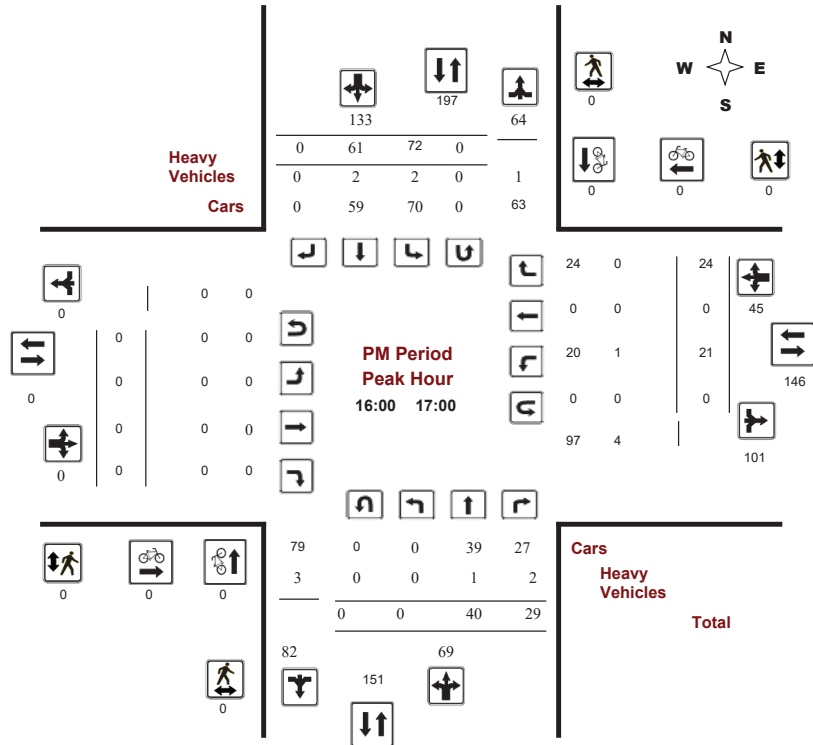

Comments



Transportation Services - Traffic Services

Turning Movement Count - Study Results

FRANK KENNY RD @ WILHAVEN DR

Survey Date: Wednesday, November 13, 2013
Start Time: 07:00

WO No: 924
Device: Miovision

Full Study Summary (8 HR Standard)

Survey Date: Wednesday, November 13, 2013

Total Observed U-Turns
Northbound: 0 Southbound: 0
Eastbound: 0 Westbound: 0

AADT Factor
.90

Period	Northbound				Southbound				Eastbound				Westbound				Grand Total		
	LT	ST	RT	NB TOT	LT	ST	RT	SB TOT	STR TOT	LT	ST	RT	EB TOT	LT	ST	RT		WB TOT	STR TOT
07:00-08:00	0	58	5	63	8	41	0	49	112	0	0	0	0	29	0	104	133	133	245
08:00-09:00	0	51	9	60	15	29	0	44	104	0	0	0	0	28	0	60	88	88	192
09:00-10:00	0	21	8	29	15	25	0	40	69	0	0	0	0	17	0	35	52	52	121
11:30-12:30	0	27	10	37	16	19	0	35	72	0	0	0	0	17	0	21	38	38	110
12:30-13:30	0	27	16	43	23	20	0	43	86	0	0	0	0	16	0	19	35	35	121
15:00-16:00	0	38	21	59	47	37	0	84	143	0	0	0	0	17	0	10	27	27	170
16:00-17:00	0	40	29	69	72	61	0	133	202	0	0	0	0	21	0	24	45	45	247
17:00-18:00	0	31	32	63	59	51	0	110	173	0	0	0	0	16	0	14	30	30	203
Sub Total	0	293	130	423	255	283	0	538	961	0	0	0	0	161	0	287	448	448	1409
U Turns	0	0	0	0	0	0	0	0	0	0	0	0	0	0	0	0	0	0	0
Total	0	293	130	423	255	283	0	538	961	0	0	0	0	161	0	287	448	448	1409
EQ 12Hr	0	407	181	588	354	393	0	747	1335	0	0	0	0	224	0	399	623	623	1958
Note: These values are calculated by multiplying the totals by the appropriate expansion factor.																	1.39		
AVG 12Hr	0	366	163	529	319	354	0	673	1202	0	0	0	0	202	0	359	561	561	1763
Note: These volumes are calculated by multiplying the Equivalent 12 hr. totals by the AADT factor.																	.90		
AVG 24Hr	0	479	214	693	418	464	0	882	1575	0	0	0	0	265	0	470	735	735	2310
Note: These volumes are calculated by multiplying the Average Daily 12 hr. totals by 12 to 24 expansion factor.																	1.31		
Note: U-Turns provided for approach totals. Refer to 'U-Turn' Report for specific breakdown.																			



Transportation Services - Traffic Services

Turning Movement Count - Study Results

FRANK KENNY RD @ WILHAVEN DR

Survey Date: Wednesday, November 13, 2013

WO No: 924

Start Time: 07:00

Device: Miovision

Full Study 15 Minute Increments

Table with columns: Time Period, Northbound (LT, ST, RT, N TOT, STR TOT), Southbound (LT, ST, RT, S TOT, STR TOT), Eastbound (LT, ST, RT, E TOT), Westbound (LT, ST, RT, W TOT, STR TOT), Grand Total. Rows show 15-minute intervals from 07:00 to 17:45.

Note: U-Turns are included in Totals.



Transportation Services - Traffic Services

Turning Movement Count - Study Results

FRANK KENNY RD @ WILHAVEN DR

Survey Date: Wednesday, November 13, 2013

WO No: 924

Start Time: 07:00

Device: Miovision

Full Study Cyclist Volume

Table with columns: Time Period, Northbound, Southbound, Street Total, Eastbound, Westbound, Street Total, Grand Total. Rows show 15-minute intervals from 07:00 to 17:45, with a Total row at the bottom.



Transportation Services - Traffic Services

Turning Movement Count - Study Results

FRANK KENNY RD @ WILHAVEN DR

Survey Date: Wednesday, November 13, 2013

WO No: 924

Start Time: 07:00

Device: Miovision

Full Study Pedestrian Volume

Table with 7 columns: Time Period, NB Approach, SB Approach, Total, EB Approach, WB Approach, Grand Total. Rows show pedestrian volume for various time intervals from 07:00 to 17:45, with a total of 4 pedestrians.



Transportation Services - Traffic Services

Turning Movement Count - Study Results

FRANK KENNY RD @ WILHAVEN DR

Survey Date: Wednesday, November 13, 2013

WO No: 924

Start Time: 07:00

Device: Miovision

Full Study Heavy Vehicles

Table with 18 columns: Time Period, Northbound (LT, ST, RT, N TOT), Southbound (LT, ST, RT, S TOT, STR TOT), Eastbound (LT, ST, RT, E TOT), Westbound (LT, ST, RT, W TOT, STR TOT), Grand Total. Rows show heavy vehicle volume for various time intervals from 07:00 to 17:45, with a total of 61 heavy vehicles.



Transportation Services - Traffic Services

Turning Movement Count - Study Results

FRANK KENNY RD @ WILHAVEN DR

Survey Date: Wednesday, November 13, 2013

WO No: 924

Start Time: 07:00

Device: Miovision

Full Study 15 Minute U-Turn Total

Time Period	Northbound U-Turn Total	Southbound U-Turn Total	Eastbound U-Turn Total	Westbound U-Turn Total	Total
07:00 07:15	0	0	0	0	0
07:15 07:30	0	0	0	0	0
07:30 07:45	0	0	0	0	0
07:45 08:00	0	0	0	0	0
08:00 08:15	0	0	0	0	0
08:15 08:30	0	0	0	0	0
08:30 08:45	0	0	0	0	0
08:45 09:00	0	0	0	0	0
09:00 09:15	0	0	0	0	0
09:15 09:30	0	0	0	0	0
09:30 09:45	0	0	0	0	0
09:45 10:00	0	0	0	0	0
11:30 11:45	0	0	0	0	0
11:45 12:00	0	0	0	0	0
12:00 12:15	0	0	0	0	0
12:15 12:30	0	0	0	0	0
12:30 12:45	0	0	0	0	0
12:45 13:00	0	0	0	0	0
13:00 13:15	0	0	0	0	0
13:15 13:30	0	0	0	0	0
15:00 15:15	0	0	0	0	0
15:15 15:30	0	0	0	0	0
15:30 15:45	0	0	0	0	0
15:45 16:00	0	0	0	0	0
16:00 16:15	0	0	0	0	0
16:15 16:30	0	0	0	0	0
16:30 16:45	0	0	0	0	0
16:45 17:00	0	0	0	0	0
17:00 17:15	0	0	0	0	0
17:15 17:30	0	0	0	0	0
17:30 17:45	0	0	0	0	0
17:45 18:00	0	0	0	0	0
Total	0	0	0	0	0

Appendix D

Synchro Intersection Worksheets – Existing Conditions

MOVEMENT SUMMARY

Site: 101 [Trim-Old Montreal AM Existing (Site Folder: General)]

Output produced by SIDRA INTERSECTION Version: 9.1.3.210

Tamarak CCV South
Site Category: (None)
Roundabout

Vehicle Movement Performance

Mov ID	Turn Class	Demand Flows [Total HV]	Arrival Flows [Total HV]	Deg. Satn	Aver. Delay	Level of Service	95% Back Of Queue [Veh.]	Prop. Que	Eff. Stop Rate	Aver. No. of Cycles	Aver. Speed
		veh/h %	veh/h %	v/c	sec		[Veh. Dist]				km/h
South: Trim											
1	L2 All MCs	218 2.0	218 2.0	0.497	9.9	LOS A	2.7 19.0	0.38	0.50	0.38	52.2
2	T1 All MCs	1011 2.0	1011 2.0	0.497	4.3	LOS A	2.7 19.0	0.39	0.47	0.39	53.6
3	R2 All MCs	90 2.0	90 2.0	0.497	4.6	LOS A	2.6 18.8	0.40	0.44	0.40	53.6
Approach		1319 2.0	1319 2.0	0.497	5.3	LOS A	2.7 19.0	0.39	0.48	0.39	53.3
East: Old Montreal											
4	L2 All MCs	220 2.0	220 2.0	0.297	13.0	LOS B	1.4 10.2	0.72	0.84	0.72	48.6
5	T1 All MCs	233 2.0	233 2.0	0.205	5.9	LOS A	1.1 7.9	0.70	0.58	0.70	52.5
6	R2 All MCs	219 2.0	219 2.0	0.175	5.2	LOS A	0.8 5.9	0.60	0.63	0.60	53.2
Approach		672 2.0	672 2.0	0.297	8.0	LOS A	1.4 10.2	0.68	0.68	0.68	51.3
North: Trim											
7	L2 All MCs	76 2.0	76 2.0	0.234	11.7	LOS B	1.1 8.0	0.61	0.67	0.61	51.0
8	T1 All MCs	333 2.0	333 2.0	0.234	5.7	LOS A	1.2 8.3	0.60	0.60	0.60	52.6
9	R2 All MCs	26 2.0	26 2.0	0.234	5.6	LOS A	1.2 8.3	0.60	0.56	0.60	52.6
Approach		434 2.0	434 2.0	0.234	6.8	LOS A	1.2 8.3	0.60	0.61	0.60	52.3
West: St Joseph											
10	L2 All MCs	68 2.0	68 2.0	0.065	10.8	LOS B	0.3 2.0	0.50	0.71	0.50	49.5
11	T1 All MCs	71 2.0	71 2.0	0.052	4.6	LOS A	0.2 1.7	0.47	0.45	0.47	53.6
12	R2 All MCs	47 20.0	47 20.0	0.037	4.8	LOS A	0.2 1.2	0.44	0.54	0.44	53.4
Approach		186 6.5	186 6.5	0.065	6.9	LOS A	0.3 2.0	0.47	0.57	0.47	51.9
All Vehicles		2611 2.3	2611 2.3	0.497	6.3	LOS A	2.7 19.0	0.50	0.56	0.50	52.5

Site Level of Service (LOS) Method: Delay (SIDRA). Site LOS Method is specified in the Parameter Settings dialog (Options tab).
 Roundabout LOS Method: SIDRA Roundabout LOS.
 Vehicle movement LOS values are based on average delay per movement.
 Intersection and Approach LOS values are based on average delay for all vehicle movements.
 Roundabout Capacity Model: SIDRA Standard.
 Delay Model: SIDRA Standard (Control Delay: Geometric Delay is included).
 Queue Model: SIDRA queue estimation methods are used for Back of Queue and Queue at Start of Gap.
 Gap-Acceptance Capacity Formula: SIDRA Standard (Akçelik M3D).
 HV (%) values are calculated for All Movement Classes of All Heavy Vehicle Model Designation.
 Arrival Flows used in performance calculations are adjusted to include any Initial Queued Demand and Upstream Capacity Constraint effects.

SIDRA INTERSECTION 9.1 | Copyright © 2000-2023 Akcelik and Associates Pty Ltd | sidrasolutions.com
 Organisation: CGH TRANSPORTATION | Licence: NETWORK / FLOATING | Processed: Tuesday, October 22, 2024 11:09:24 AM
 Project: Not Saved

Lanes, Volumes, Timings

1: Trim Rd & St Joseph Blvd/Old Montreal Rd

10/22/2024



Lane Group	EBL	EBT	EBR	WBL	WBT	WBR	NBL	NBT	NBR	SBL	SBT	SBR
Lane Configurations		↕↕	↕		↕↕	↕		↕↕				↕↕
Traffic Volume (vph)	61	64	42	198	210	197	196	910	81	68	300	23
Future Volume (vph)	61	64	42	198	210	197	196	910	81	68	300	23
Satd. Flow (prot)	0	3029	1375	0	3146	1483	0	3232	0	0	3125	0
Fit Permitted		0.976			0.976			0.992			0.991	
Satd. Flow (perm)	0	3029	1375	0	3146	1483	0	3232	0	0	3125	0
Lane Group Flow (vph)	0	139	47	0	453	219	0	1319	0	0	435	0
Sign Control		Yield			Yield			Yield			Yield	

Intersection Summary

Control Type: Roundabout

Intersection Capacity Utilization 76.5% ICU Level of Service D

Analysis Period (min) 15

Intersection												
Int Delay, s/veh	0.7											
Movement	EBL	EBT	EBR	WBL	WBT	WBR	NBL	NBT	NBR	SBL	SBT	SBR
Lane Configurations	↔	↔		↔	↔			↔		↔	↔	
Traffic Vol, veh/h	9	118	5	0	360	99	9	7	0	6	0	5
Future Vol, veh/h	9	118	5	0	360	99	9	7	0	6	0	5
Conflicting Peds, #/hr	0	0	1	1	0	0	2	0	0	0	0	2
Sign Control	Free	Free	Free	Free	Free	Free	Stop	Stop	Stop	Stop	Stop	Stop
RT Channelized	-	-	None	-	-	None	-	-	None	-	-	None
Storage Length	55	-	-	70	-	-	-	-	-	30	-	-
Veh in Median Storage, #	-	0	-	-	0	-	-	0	-	-	0	-
Grade, %	-	0	-	-	0	-	-	0	-	-	0	-
Peak Hour Factor	90	90	90	90	90	90	90	90	90	90	90	90
Heavy Vehicles, %	2	10	2	2	3	2	2	2	2	17	2	2
Mvmt Flow	10	131	6	0	400	110	10	8	0	7	0	6

Major/Minor	Major1	Major2	Minor1	Minor2
Conflicting Flow All	510	0	138	0
Stage 1	-	-	-	-
Stage 2	-	-	-	-
Critical Hdwy	4.12	-	4.12	-
Critical Hdwy Stg 1	-	-	-	-
Critical Hdwy Stg 2	-	-	-	-
Follow-up Hdwy	2.218	-	2.218	-
Pot Cap-1 Maneuver	1055	-	1446	-
Stage 1	-	-	-	-
Stage 2	-	-	-	-
Platoon blocked, %	-	-	-	-
Mov Cap-1 Maneuver	1055	-	1445	-
Mov Cap-2 Maneuver	-	-	-	-
Stage 1	-	-	-	-
Stage 2	-	-	-	-

Approach	EB	WB	NB	SB
HCM Control Delay, s	0.6	0	14.8	13.1
HCM LOS			B	B

Minor Lane/Major Mvmt	NBLn1	EBL	EBT	EBR	WBL	WBT	WBR	SBLn1	SBLn2
Capacity (veh/h)	387	1055	-	-	1445	-	-	375	603
HCM Lane V/C Ratio	0.046	0.009	-	-	-	-	-	0.018	0.009
HCM Control Delay (s)	14.8	8.4	-	-	0	-	-	14.8	11
HCM Lane LOS	B	A	-	-	A	-	-	B	B
HCM 95th %tile Q(veh)	0.1	0	-	-	0	-	-	0.1	0

Intersection						
Int Delay, s/veh	3					
Movement	EBL	EBT	WBT	WBR	SBL	SBR
Lane Configurations	↔	↔	↔		↔	↔
Traffic Vol, veh/h	51	71	350	9	8	104
Future Vol, veh/h	51	71	350	9	8	104
Conflicting Peds, #/hr	0	0	0	0	0	0
Sign Control	Free	Free	Free	Free	Stop	Stop
RT Channelized	-	None	-	None	-	None
Storage Length	155	-	-	-	0	-
Veh in Median Storage, #	-	0	0	-	0	-
Grade, %	-	0	0	-	0	-
Peak Hour Factor	90	90	90	90	90	90
Heavy Vehicles, %	10	13	2	2	2	8
Mvmt Flow	57	79	389	10	9	116

Major/Minor	Major1	Major2	Minor2
Conflicting Flow All	399	0	0
Stage 1	-	-	-
Stage 2	-	-	-
Critical Hdwy	4.2	-	-
Critical Hdwy Stg 1	-	-	-
Critical Hdwy Stg 2	-	-	-
Follow-up Hdwy	2.29	-	-
Pot Cap-1 Maneuver	1118	-	-
Stage 1	-	-	-
Stage 2	-	-	-
Platoon blocked, %	-	-	-
Mov Cap-1 Maneuver	1118	-	-
Mov Cap-2 Maneuver	-	-	-
Stage 1	-	-	-
Stage 2	-	-	-

Approach	EB	WB	SB
HCM Control Delay, s	3.5	0	12.2
HCM LOS			B

Minor Lane/Major Mvmt	EBL	EBT	WBT	WBR	SBLn1
Capacity (veh/h)	1118	-	-	-	623
HCM Lane V/C Ratio	0.051	-	-	-	0.2
HCM Control Delay (s)	8.4	-	-	-	12.2
HCM Lane LOS	A	-	-	-	B
HCM 95th %tile Q(veh)	0.2	-	-	-	0.7

HCM 2010 TWSC
4: Old Montreal Rd & Cardinal Creek Dr

10/22/2024

Intersection						
Int Delay, s/veh	0.3					
Movement	EBL	EBT	WBT	WBR	SBL	SBR
Lane Configurations		↕	↕		↕	
Traffic Vol, veh/h	11	66	350	8	0	4
Future Vol, veh/h	11	66	350	8	0	4
Conflicting Peds, #/hr	0	0	0	0	0	0
Sign Control	Free	Free	Free	Free	Stop	Stop
RT Channelized	-	None	-	None	-	None
Storage Length	-	-	-	-	0	-
Veh in Median Storage, #	-	0	0	-	0	-
Grade, %	-	0	0	-	0	-
Peak Hour Factor	90	90	90	90	90	90
Heavy Vehicles, %	27	2	2	25	2	75
Mvmt Flow	12	73	389	9	0	4

Major/Minor	Major1	Major2	Minor2
Conflicting Flow All	398	0	491
Stage 1	-	-	394
Stage 2	-	-	97
Critical Hdwy	4.37	-	6.42
Critical Hdwy Stg 1	-	-	5.42
Critical Hdwy Stg 2	-	-	5.42
Follow-up Hdwy	2.443	-	3.518
Pot Cap-1 Maneuver	1037	-	537
Stage 1	-	-	681
Stage 2	-	-	927
Platoon blocked, %	-	-	-
Mov Cap-1 Maneuver	1037	-	531
Mov Cap-2 Maneuver	-	-	531
Stage 1	-	-	673
Stage 2	-	-	927

Approach	EB	WB	SB
HCM Control Delay, s	1.2	0	12
HCM LOS			B

Minor Lane/Major Mvmt	EBL	EBT	WBT	WBR	SBLn1
Capacity (veh/h)	1037	-	-	-	522
HCM Lane V/C Ratio	0.012	-	-	-	0.009
HCM Control Delay (s)	8.5	0	-	-	12
HCM Lane LOS	A	A	-	-	B
HCM 95th %tile Q(veh)	0	-	-	-	0

HCM 2010 TWSC
5: Cox Country Rd/Ted Kelly Ln & Old Montreal Rd

10/22/2024

Intersection												
Int Delay, s/veh	5											
Movement	EBL	EBT	EBR	WBL	WBT	WBR	NBL	NBT	NBR	SBL	SBT	SBR
Lane Configurations		↕		↕	↕		↕	↕		↕	↕	
Traffic Vol, veh/h	3	38	25	31	216	2	134	1	15	1	2	8
Future Vol, veh/h	3	38	25	31	216	2	134	1	15	1	2	8
Conflicting Peds, #/hr	0	0	0	0	0	0	0	0	0	0	0	0
Sign Control	Free	Free	Free	Free	Free	Free	Stop	Stop	Stop	Stop	Stop	Stop
RT Channelized	-	-	None	-	-	None	-	-	None	-	-	None
Storage Length	-	-	-	-	-	-	-	-	-	-	-	-
Veh in Median Storage, #	-	0	-	-	0	-	-	0	-	-	0	-
Grade, %	-	0	-	-	0	-	-	0	-	-	0	-
Peak Hour Factor	90	90	90	90	90	90	90	90	90	90	90	90
Heavy Vehicles, %	2	3	2	3	3	2	2	2	7	2	2	2
Mvmt Flow	3	42	28	34	240	2	149	1	17	1	2	9

Major/Minor	Major1	Major2	Minor1	Minor2
Conflicting Flow All	242	0	70	377
Stage 1	-	-	-	62
Stage 2	-	-	-	315
Critical Hdwy	4.12	-	4.13	7.12
Critical Hdwy Stg 1	-	-	-	6.12
Critical Hdwy Stg 2	-	-	-	6.12
Follow-up Hdwy	2.218	-	2.227	3.518
Pot Cap-1 Maneuver	1324	-	1524	580
Stage 1	-	-	-	949
Stage 2	-	-	-	696
Platoon blocked, %	-	-	-	-
Mov Cap-1 Maneuver	1324	-	1524	560
Mov Cap-2 Maneuver	-	-	-	560
Stage 1	-	-	-	947
Stage 2	-	-	-	668

Approach	EB	WB	NB	SB
HCM Control Delay, s	0.4	0.9	13.6	10.2
HCM LOS			B	B

Minor Lane/Major Mvmt	NBLn1	EBL	EBT	EBR	WBL	WBT	WBR	SBLn1
Capacity (veh/h)	586	1324	-	-	1524	-	-	706
HCM Lane V/C Ratio	0.284	0.003	-	-	0.023	-	-	0.017
HCM Control Delay (s)	13.6	7.7	0	-	7.4	0	-	10.2
HCM Lane LOS	B	A	A	-	A	A	-	B
HCM 95th %tile Q(veh)	1.2	0	-	-	0.1	-	-	0.1

Intersection						
Int Delay, s/veh	5.1					
Movement	WBL	WBR	NBT	NBR	SBL	SBT
Lane Configurations	↔		↔			↔
Traffic Vol, veh/h	33	94	56	8	9	49
Future Vol, veh/h	33	94	56	8	9	49
Conflicting Peds, #/hr	0	0	0	0	0	0
Sign Control	Stop	Stop	Free	Free	Free	Free
RT Channelized	-	None	-	None	-	None
Storage Length	0	-	-	-	-	-
Veh in Median Storage, #	0	-	0	-	-	0
Grade, %	0	-	0	-	-	0
Peak Hour Factor	90	90	90	90	90	90
Heavy Vehicles, %	6	5	3	2	2	11
Mvmt Flow	37	104	62	9	10	54

Major/Minor	Minor1	Major1	Major2
Conflicting Flow All	141	67	0
Stage 1	67	-	-
Stage 2	74	-	-
Critical Hdwy	6.46	6.25	-
Critical Hdwy Stg 1	5.46	-	-
Critical Hdwy Stg 2	5.46	-	-
Follow-up Hdwy	3.554	3.345	-
Pot Cap-1 Maneuver	843	988	-
Stage 1	946	-	-
Stage 2	939	-	-
Platoon blocked, %	-	-	-
Mov Cap-1 Maneuver	837	988	-
Mov Cap-2 Maneuver	837	-	-
Stage 1	946	-	-
Stage 2	932	-	-

Approach	WB	NB	SB
HCM Control Delay, s	9.5	0	1.1
HCM LOS	A		

Minor Lane/Major Mvmt	NBT	NBRWBLn1	SBL	SBT
Capacity (veh/h)	-	-	944	1529
HCM Lane V/C Ratio	-	-	0.149	0.007
HCM Control Delay (s)	-	-	9.5	7.4
HCM Lane LOS	-	-	A	A
HCM 95th %tile Q(veh)	-	-	0.5	0

MOVEMENT SUMMARY

Site: 101 [Trim-Old Montreal PM Existing (Site Folder: General)]

Output produced by SIDRA INTERSECTION Version: 9.1.3.210

Tamarak CCV South
Site Category: (None)
Roundabout

Vehicle Movement Performance													
Mov ID	Turn	Mov Class	Demand Flows [Total HV]	Arrival Flows [Total HV]	Deg. Satn	Aver. Delay	Level of Service	95% Back Of Queue [Veh.]	Prop. Que	Eff. Stop Rate	Aver. No. of Cycles	Aver. Speed	
			veh/h %	veh/h %	v/c	sec		Dist m				km/h	
South: Trim													
1	L2	All MCs	137 2.0	137 2.0	0.399	10.9	LOS B	2.0	14.4	0.59	0.60	0.59	51.4
2	T1	All MCs	544 2.0	544 2.0	0.399	5.4	LOS A	2.0	14.4	0.59	0.60	0.60	52.7
3	R2	All MCs	130 2.0	130 2.0	0.399	5.9	LOS A	2.0	14.0	0.60	0.60	0.61	52.7
Approach			811 2.0	811 2.0	0.399	6.4	LOS A	2.0	14.4	0.59	0.60	0.60	52.4
East: Old Montreal													
4	L2	All MCs	141 2.0	141 2.0	0.148	11.1	LOS B	0.7	4.8	0.58	0.73	0.58	49.2
5	T1	All MCs	167 2.0	167 2.0	0.130	4.9	LOS A	0.6	4.6	0.55	0.48	0.55	53.2
6	R2	All MCs	143 2.0	143 2.0	0.105	4.6	LOS A	0.5	3.5	0.48	0.55	0.48	53.7
Approach			451 2.0	451 2.0	0.148	6.7	LOS A	0.7	4.8	0.54	0.58	0.54	52.0
North: Trim													
7	L2	All MCs	366 2.0	366 2.0	0.807	15.9	LOS B	9.9	70.4	0.87	0.92	1.20	48.6
8	T1	All MCs	1318 2.0	1318 2.0	0.807	9.4	LOS A	10.1	71.7	0.85	0.88	1.15	51.0
9	R2	All MCs	68 2.0	68 2.0	0.807	9.1	LOS A	10.1	71.7	0.84	0.86	1.12	51.4
Approach			1751 2.0	1751 2.0	0.807	10.8	LOS B	10.1	71.7	0.85	0.89	1.16	50.5
West: St Joseph													
10	L2	All MCs	47 2.0	47 2.0	0.246	14.5	LOS B	1.3	9.3	0.86	0.88	0.86	49.5
11	T1	All MCs	240 2.0	240 2.0	0.246	8.2	LOS A	1.7	11.9	0.91	0.81	0.91	51.1
12	R2	All MCs	260 2.0	260 2.0	0.309	6.8	LOS A	2.1	14.6	0.88	0.79	0.88	52.3
Approach			547 2.0	547 2.0	0.309	8.1	LOS A	2.1	14.6	0.89	0.81	0.89	51.5
All Vehicles			3560 2.0	3560 2.0	0.807	8.8	LOS A	10.1	71.7	0.76	0.77	0.91	51.2

Site Level of Service (LOS) Method: Delay (SIDRA). Site LOS Method is specified in the Parameter Settings dialog (Options tab).
 Roundabout LOS Method: SIDRA Roundabout LOS.
 Vehicle movement LOS values are based on average delay per movement.
 Intersection and Approach LOS values are based on average delay for all vehicle movements.
 Roundabout Capacity Model: SIDRA Standard.
 Delay Model: SIDRA Standard (Control Delay: Geometric Delay is included).
 Queue Model: SIDRA queue estimation methods are used for Back of Queue and Queue at Start of Gap.
 Gap-Acceptance Capacity Formula: SIDRA Standard (Akgelik M3D).
 HV (%) values are calculated for All Movement Classes of All Heavy Vehicle Model Designation.
 Arrival Flows used in performance calculations are adjusted to include any Initial Queued Demand and Upstream Capacity Constraint effects.

Lanes, Volumes, Timings

1: Trim Rd & St Joseph Blvd/Old Montreal Rd

10/22/2024



Lane Group	EBL	EBT	EBR	WBL	WBT	WBR	NBL	NBT	NBR	SBL	SBT	SBR
Lane Configurations		↕↕	↕		↕↕	↕		↕↕			↕↕	
Traffic Volume (vph)	42	216	234	127	150	129	123	490	117	329	1186	61
Future Volume (vph)	42	216	234	127	150	129	123	490	117	329	1186	61
Satd. Flow (prot)	0	3289	1483	0	3243	1483	0	3189	0	0	3263	0
Fit Permitted		0.992			0.978			0.992			0.990	
Satd. Flow (perm)	0	3289	1483	0	3243	1483	0	3189	0	0	3263	0
Lane Group Flow (vph)	0	287	260	0	308	143	0	811	0	0	1752	0
Sign Control		Yield			Yield			Yield			Yield	

Intersection Summary	
Control Type:	Roundabout
Intersection Capacity Utilization	98.3%
ICU Level of Service F	
Analysis Period (min)	15

HCM 2010 TWSC

2: Aveia Private/Dairy Dr & Old Montreal Rd

10/22/2024

Intersection												
Int Delay, s/veh	2.8											
Movement	EBL	EBT	EBR	WBL	WBT	WBR	NBL	NBT	NBR	SBL	SBT	SBR
Lane Configurations	↕	↕		↕	↕			↕↕		↕	↕	
Traffic Vol, veh/h	3	494	9	1	173	21	4	6	1	88	2	20
Future Vol, veh/h	3	494	9	1	173	21	4	6	1	88	2	20
Conflicting Peds, #/hr	1	0	0	0	0	1	0	0	2	2	0	0
Sign Control	Free	Free	Free	Free	Free	Free	Stop	Stop	Stop	Stop	Stop	Stop
RT Channelized	-	-	None	-	-	None	-	-	None	-	-	None
Storage Length	55	-	-	70	-	-	-	-	-	30	-	-
Veh in Median Storage, #	-	0	-	-	0	-	-	0	-	0	-	-
Grade, %	-	0	-	-	0	-	-	0	-	-	0	-
Peak Hour Factor	90	90	90	90	90	90	90	90	90	90	90	90
Heavy Vehicles, %	33	2	2	2	6	2	2	2	2	2	2	10
Mvmt Flow	3	549	10	1	192	23	4	7	1	98	2	22

Major/Minor	Major1	Major2	Minor1	Minor2
Conflicting Flow All	216	0	559	0
Stage 1	-	-	-	-
Stage 2	-	-	-	-
Critical Hdwy	4.43	-	4.12	-
Critical Hdwy Stg 1	-	-	-	-
Critical Hdwy Stg 2	-	-	-	-
Follow-up Hdwy	2.497	-	2.218	-
Pot Cap-1 Maneuver	1190	-	1012	-
Stage 1	-	-	-	-
Stage 2	-	-	-	-
Platoon blocked, %	-	-	-	-
Mov Cap-1 Maneuver	1189	-	1012	-
Mov Cap-2 Maneuver	-	-	-	-
Stage 1	-	-	-	-
Stage 2	-	-	-	-

Approach	EB	WB	NB	SB
HCM Control Delay, s	0	0	16.4	19.6
HCM LOS			C	C

Minor Lane/Major Mvmt	NBLn1	EBL	EBT	EBR	WBL	WBT	WBR	SBLn1	SBLn2
Capacity (veh/h)	328	1189	-	-	1012	-	-	309	718
HCM Lane V/C Ratio	0.037	0.003	-	-	0.001	-	-	0.316	0.034
HCM Control Delay (s)	16.4	8	-	-	8.6	-	-	22	10.2
HCM Lane LOS	C	A	-	-	A	-	-	C	B
HCM 95th %tile Q(veh)	0.1	0	-	-	0	-	-	1.3	0.1

HCM 2010 TWSC
3: Old Montreal Rd & Famille-Laporte Ave

10/22/2024

Intersection						
Int Delay, s/veh	2.3					
Movement	EBL	EBT	WBT	WBR	SBL	SBR
Lane Configurations	↖	↑	↗		↖	↗
Traffic Vol, veh/h	116	462	119	8	10	74
Future Vol, veh/h	116	462	119	8	10	74
Conflicting Peds, #/hr	0	0	0	0	0	0
Sign Control	Free	Free	Free	Free	Stop	Stop
RT Channelized	-	None	-	None	-	None
Storage Length	155	-	-	-	0	-
Veh in Median Storage, #	-	0	0	-	0	-
Grade, %	-	0	0	-	0	-
Peak Hour Factor	90	90	90	90	90	90
Heavy Vehicles, %	4	2	2	2	2	3
Mvmt Flow	129	513	132	9	11	82

Major/Minor	Major1	Major2	Minor2		
Conflicting Flow All	141	0	0	908	137
Stage 1	-	-	-	137	-
Stage 2	-	-	-	771	-
Critical Hdwy	4.14	-	-	6.42	6.23
Critical Hdwy Stg 1	-	-	-	5.42	-
Critical Hdwy Stg 2	-	-	-	5.42	-
Follow-up Hdwy	2.236	-	-	3.518	3.327
Pot Cap-1 Maneuver	1430	-	-	306	909
Stage 1	-	-	-	890	-
Stage 2	-	-	-	456	-
Platoon blocked, %	-	-	-	-	-
Mov Cap-1 Maneuver	1430	-	-	278	909
Mov Cap-2 Maneuver	-	-	-	278	-
Stage 1	-	-	-	810	-
Stage 2	-	-	-	456	-

Approach	EB	WB	SB
HCM Control Delay, s	1.6	0	10.8
HCM LOS			B

Minor Lane/Major Mvmt	EBL	EBT	WBT	WBR	SBLn1
Capacity (veh/h)	1430	-	-	-	716
HCM Lane V/C Ratio	0.09	-	-	-	0.13
HCM Control Delay (s)	7.8	-	-	-	10.8
HCM Lane LOS	A	-	-	-	B
HCM 95th %tile Q(veh)	0.3	-	-	-	0.4

HCM 2010 TWSC
4: Old Montreal Rd & Cardinal Creek Dr

10/22/2024

Intersection						
Int Delay, s/veh	0.3					
Movement	EBL	EBT	WBT	WBR	SBL	SBR
Lane Configurations		↖	↗		↖	↗
Traffic Vol, veh/h	10	457	119	1	2	6
Future Vol, veh/h	10	457	119	1	2	6
Conflicting Peds, #/hr	0	0	0	0	0	0
Sign Control	Free	Free	Free	Free	Stop	Stop
RT Channelized	-	None	-	None	-	None
Storage Length	-	-	-	-	0	-
Veh in Median Storage, #	-	0	0	-	0	-
Grade, %	-	0	0	-	0	-
Peak Hour Factor	90	90	90	90	90	90
Heavy Vehicles, %	10	2	2	2	50	17
Mvmt Flow	11	508	132	1	2	7

Major/Minor	Major1	Major2	Minor2		
Conflicting Flow All	133	0	0	663	133
Stage 1	-	-	-	133	-
Stage 2	-	-	-	530	-
Critical Hdwy	4.2	-	-	6.9	6.37
Critical Hdwy Stg 1	-	-	-	5.9	-
Critical Hdwy Stg 2	-	-	-	5.9	-
Follow-up Hdwy	2.29	-	-	3.95	3.453
Pot Cap-1 Maneuver	1404	-	-	360	878
Stage 1	-	-	-	788	-
Stage 2	-	-	-	504	-
Platoon blocked, %	-	-	-	-	-
Mov Cap-1 Maneuver	1404	-	-	356	878
Mov Cap-2 Maneuver	-	-	-	356	-
Stage 1	-	-	-	779	-
Stage 2	-	-	-	504	-

Approach	EB	WB	SB
HCM Control Delay, s	0.2	0	10.7
HCM LOS			B

Minor Lane/Major Mvmt	EBL	EBT	WBT	WBR	SBLn1
Capacity (veh/h)	1404	-	-	-	642
HCM Lane V/C Ratio	0.008	-	-	-	0.014
HCM Control Delay (s)	7.6	0	-	-	10.7
HCM Lane LOS	A	A	-	-	B
HCM 95th %tile Q(veh)	0	-	-	-	0

Intersection												
Int Delay, s/veh	2.3											
Movement	EBL	EBT	EBR	WBL	WBT	WBR	NBL	NBT	NBR	SBL	SBT	SBR
Lane Configurations	↔			↔			↔			↔		
Traffic Vol, veh/h	12	332	115	23	81	1	34	6	39	0	2	5
Future Vol, veh/h	12	332	115	23	81	1	34	6	39	0	2	5
Conflicting Peds, #/hr	0	0	0	0	0	0	0	0	2	0	0	0
Sign Control	Free	Free	Free	Free	Free	Free	Stop	Stop	Stop	Stop	Stop	Stop
RT Channelized	-	-	None	-	-	None	-	-	None	-	-	None
Storage Length	-	-	-	-	-	-	-	-	-	-	-	-
Veh in Median Storage, #	-	0	-	-	0	-	-	0	-	-	0	-
Grade, %	-	0	-	-	0	-	-	0	-	-	0	-
Peak Hour Factor	90	90	90	90	90	90	90	90	90	90	90	90
Heavy Vehicles, %	2	2	3	2	2	2	2	17	3	2	2	2
Mvmt Flow	13	369	128	26	90	1	38	7	43	0	2	6

Major/Minor	Major1		Major2		Minor1		Minor2					
Conflicting Flow All	91	0	0	497	0	0	606	602	435	629	666	91
Stage 1	-	-	-	-	-	-	459	459	-	143	143	-
Stage 2	-	-	-	-	-	-	147	143	-	486	523	-
Critical Hdwy	4.12	-	-	4.12	-	-	7.12	6.67	6.23	7.12	6.52	6.22
Critical Hdwy Stg 1	-	-	-	-	-	-	6.12	5.67	-	6.12	5.52	-
Critical Hdwy Stg 2	-	-	-	-	-	-	6.12	5.67	-	6.12	5.52	-
Follow-up Hdwy	2,218	-	-	2,218	-	-	3,518	4,153	3,327	3,518	4,018	3,318
Pot Cap-1 Maneuver	1504	-	-	1067	-	-	409	394	619	395	380	967
Stage 1	-	-	-	-	-	-	582	542	-	860	779	-
Stage 2	-	-	-	-	-	-	856	751	-	563	530	-
Platoon blocked, %	-	-	-	-	-	-	-	-	-	-	-	-
Mov Cap-1 Maneuver	1504	-	-	1067	-	-	393	379	618	352	366	967
Mov Cap-2 Maneuver	-	-	-	-	-	-	393	379	-	352	366	-
Stage 1	-	-	-	-	-	-	575	535	-	850	759	-
Stage 2	-	-	-	-	-	-	827	731	-	510	524	-

Approach	EB	WB	NB	SB
HCM Control Delay, s	0.2	1.9	14.2	10.5
HCM LOS			B	B

Minor Lane/Major Mvmt	NBLn1	EBL	EBT	EBR	WBL	WBT	WBR	SBLn1
Capacity (veh/h)	477	1504	-	-	1067	-	-	658
HCM Lane V/C Ratio	0.184	0.009	-	-	0.024	-	-	0.012
HCM Control Delay (s)	14.2	7.4	0	-	8.5	0	-	10.5
HCM Lane LOS	B	A	A	-	A	A	-	B
HCM 95th %tile Q(veh)	0.7	0	-	-	0.1	-	-	0

Intersection						
Int Delay, s/veh	3.7					
Movement	WBL	WBR	NBT	NBR	SBL	SBT
Lane Configurations	↔		↔		↔	
Traffic Vol, veh/h	21	24	55	29	72	68
Future Vol, veh/h	21	24	55	29	72	68
Conflicting Peds, #/hr	0	0	0	0	0	0
Sign Control	Stop	Stop	Free	Free	Free	Free
RT Channelized	-	None	-	None	-	None
Storage Length	0	-	-	-	-	-
Veh in Median Storage, #	0	-	0	-	-	0
Grade, %	0	-	0	-	-	0
Peak Hour Factor	90	90	90	90	90	90
Heavy Vehicles, %	5	2	3	7	3	3
Mvmt Flow	23	27	61	32	80	76

Major/Minor	Minor1	Major1	Major2			
Conflicting Flow All	313	77	0	0	93	0
Stage 1	77	-	-	-	-	-
Stage 2	236	-	-	-	-	-
Critical Hdwy	6.45	6.22	-	-	4.13	-
Critical Hdwy Stg 1	5.45	-	-	-	-	-
Critical Hdwy Stg 2	5.45	-	-	-	-	-
Follow-up Hdwy	3,545	3,318	-	-	2,227	-
Pot Cap-1 Maneuver	674	984	-	-	1495	-
Stage 1	938	-	-	-	-	-
Stage 2	796	-	-	-	-	-
Platoon blocked, %	-	-	-	-	-	-
Mov Cap-1 Maneuver	636	984	-	-	1495	-
Mov Cap-2 Maneuver	636	-	-	-	-	-
Stage 1	938	-	-	-	-	-
Stage 2	751	-	-	-	-	-

Approach	WB	NB	SB
HCM Control Delay, s	9.9	0	3.9
HCM LOS	A		

Minor Lane/Major Mvmt	NBT	NBR	WBLn1	SBL	SBT
Capacity (veh/h)	-	-	784	1495	-
HCM Lane V/C Ratio	-	-	0.064	0.054	-
HCM Control Delay (s)	-	-	9.9	7.5	0
HCM Lane LOS	-	-	A	A	A
HCM 95th %tile Q(veh)	-	-	0.2	0.2	-

Appendix E

Collision Data

Accident Date	Accident Year	Accident Time	Location	Environment Condition	Light	Traffic Control	Traffic Control Condition	Classification Of Accident	Initial Impact Type	Road Surface Condition
7/11/2015	2015	12:11	AVEIA PRIV/DAIRY DR @ OLD MONTREAL RD	01 - Clear	01 - Daylight	0		02 - Non-fatal injury	07 - SMV other	01 - Dry
6/15/2018	2018	18:47	AVEIA PRIV/DAIRY DR @ OLD MONTREAL RD (0014909)	01 - Clear	01 - Daylight	02 - Stop sign		02 - Non-fatal injury	02 - Angle	01 - Dry
11/22/2019	2019	17:02	AVEIA PRIV/DAIRY DR @ OLD MONTREAL RD (0014909)	01 - Clear	07 - Dark	02 - Stop sign		03 - P.D. only	02 - Angle	01 - Dry
11/26/2019	2019	16:35	AVEIA PRIV/DAIRY DR @ OLD MONTREAL RD (0014909)	01 - Clear	05 - Dusk	01 - Traffic signal		03 - P.D. only	02 - Angle	01 - Dry
7/5/2015	2015	14:58	FRANK KENNY RD btwn JONQUILLE WAY & WILHAVEN DR	01 - Clear	01 - Daylight	10 - No control		02 - Non-fatal injury	01 - Approaching	01 - Dry
6/2/2016	2016	13:58	FRANK KENNY RD btwn JONQUILLE WAY & WILHAVEN DR	01 - Clear	01 - Daylight	10 - No control		02 - Non-fatal injury	07 - SMV other	02 - Wet
7/6/2017	2017	15:58	FRANK KENNY RD btwn JONQUILLE WAY & WILHAVEN DR	01 - Clear	01 - Daylight	10 - No control		02 - Non-fatal injury	07 - SMV other	01 - Dry
11/30/2017	2017	16:43	FRANK KENNY RD btwn JONQUILLE WAY & WILHAVEN DR	02 - Rain	05 - Dusk	10 - No control		02 - Non-fatal injury	07 - SMV other	05 - Ice
1/16/2019	2019	17:00	FRANK KENNY RD btwn JONQUILLE WAY & WILHAVEN DR (__32A5C)	01 - Clear	05 - Dusk	10 - No control		03 - P.D. only	07 - SMV other	06 - Ice
12/21/2019	2019	0:00	FRANK KENNY RD btwn JONQUILLE WAY & WILHAVEN DR (__32A5C)	01 - Clear	00 - Unknown	10 - No control		03 - P.D. only	07 - SMV other	06 - Ice
2/21/2019	2019	14:09	FRANK KENNY RD/TED KELLY LANE @ OLD MONTREAL R (0003616)	01 - Clear	01 - Daylight	02 - Stop sign		02 - Non-fatal injury	02 - Angle	02 - Wet
7/18/2019	2019	6:11	FRANK KENNY RD/TED KELLY LANE @ OLD MONTREAL R (0003616)	01 - Clear	01 - Daylight	02 - Stop sign		02 - Non-fatal injury	07 - SMV other	01 - Dry
3/3/2015	2015	9:34	OLD MONTREAL RD btwn Continuation of OLD MONTREAL RD & GRAND-CH-NE, CO	01 - Clear	01 - Daylight	10 - No control		03 - P.D. only	03 - Rear end	01 - Dry
1/15/2015	2015	22:52	OLD MONTREAL RD btwn GRAND-CH-NE, COUR DU CRT & TED KELLY LANE	03 - Snow	07 - Dark	10 - No control		03 - P.D. only	07 - SMV other	05 - Packed snow
8/12/2015	2015	18:27	OLD MONTREAL RD btwn GRAND-CH-NE, COUR DU CRT & TED KELLY LANE	01 - Clear	01 - Daylight	10 - No control		03 - P.D. only	07 - SMV other	01 - Dry
12/3/2017	2017	0:52	OLD MONTREAL RD btwn GRAND-CH-NE, COUR DU CRT & TED KELLY LANE	03 - Snow	07 - Dark	10 - No control		03 - P.D. only	07 - SMV other	02 - Wet
5/22/2018	2018	18:00	OLD MONTREAL RD btwn GRAND-CH-NE, COUR DU CRT & TED KELLY LANE (__32A24E)	01 - Clear	01 - Daylight	10 - No control		02 - Non-fatal injury	07 - SMV other	01 - Dry
11/27/2018	2018	7:59	OLD MONTREAL RD btwn GRAND-CH-NE, COUR DU CRT & TED KELLY LANE (__32A24E)	03 - Snow	01 - Daylight	10 - No control		03 - P.D. only	01 - Approaching	04 - Slush
12/8/2018	2018	19:00	OLD MONTREAL RD btwn GRAND-CH-NE, COUR DU CRT & TED KELLY LANE (__32A24E)	03 - Snow	07 - Dark	10 - No control		03 - P.D. only	07 - SMV other	03 - Loose snow
3/30/2019	2019	12:34	OLD MONTREAL RD btwn GRAND-CH-NE, COUR DU CRT & TED KELLY LANE (__32A24E)	04 - Freezing Rain	01 - Daylight	10 - No control		02 - Non-fatal injury	07 - SMV other	03 - Loose snow
12/23/2017	2017	15:33	ANTIGONISH AVE @ OLD MONTREAL RD	03 - Snow	01 - Daylight	02 - Stop sign		03 - P.D. only	02 - Angle	03 - Loose snow
10/6/2017	2017	6:25	OLD MONTREAL RD btwn GERALD ST & Continuation of OLD MONTREAL RD	01 - Clear	03 - Dawn	10 - No control		03 - P.D. only	04 - Sideswipe	01 - Dry
6/16/2019	2019	10:30	DE LA FAMILLE-LAPORTE AVE @ OLD MONTREAL RD (0017105)	01 - Clear	01 - Daylight	02 - Stop sign		03 - P.D. only	99 - Other	01 - Dry
11/19/2019	2019	9:00	DE LA FAMILLE-LAPORTE AVE @ OLD MONTREAL RD (0017105)	01 - Clear	01 - Daylight	02 - Stop sign		03 - P.D. only	03 - Rear end	01 - Dry

Appendix F

TRANS Model Plots

TRANS Regional Model

Version 2.15 - Assigned June 16, 2020

AM Peak Hour Total Traffic Volume

Old Montreal/Cardinal Creek Area Growth

2011 Model - Basecase

N/A

User Initials: TIMW
Plot Prepared: August 10, 2020
EMME Scenario: 21711



Legend

AM Peak Hour Total Traffic Volume

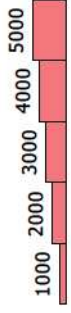

Distance (m)



N



The TRANS model is continuously refined & maintained, and all information is provided in good faith. However, model outputs are provided "as is", and no warranty or guarantee is provided as to the accuracy, reliability or reasonableness of the results. In using this data, you agree to accept any and all risks arising from any incorrect, incomplete, or misleading information.

Recipients are required to use caution and professional judgement in using and interpreting model outputs. In particular, caution should be used when focusing on a geographically limited area (such as a single road or intersection), as the model is primarily designed to simulate regional-scale phenomena and has been calibrated at a regional level.

As general good practice, it is recommended that the user confirm the network coding within the area of interest, and compare base year forecasts against traffic count data to assess the extent to which the model may be over- or under-estimating the travel demand.

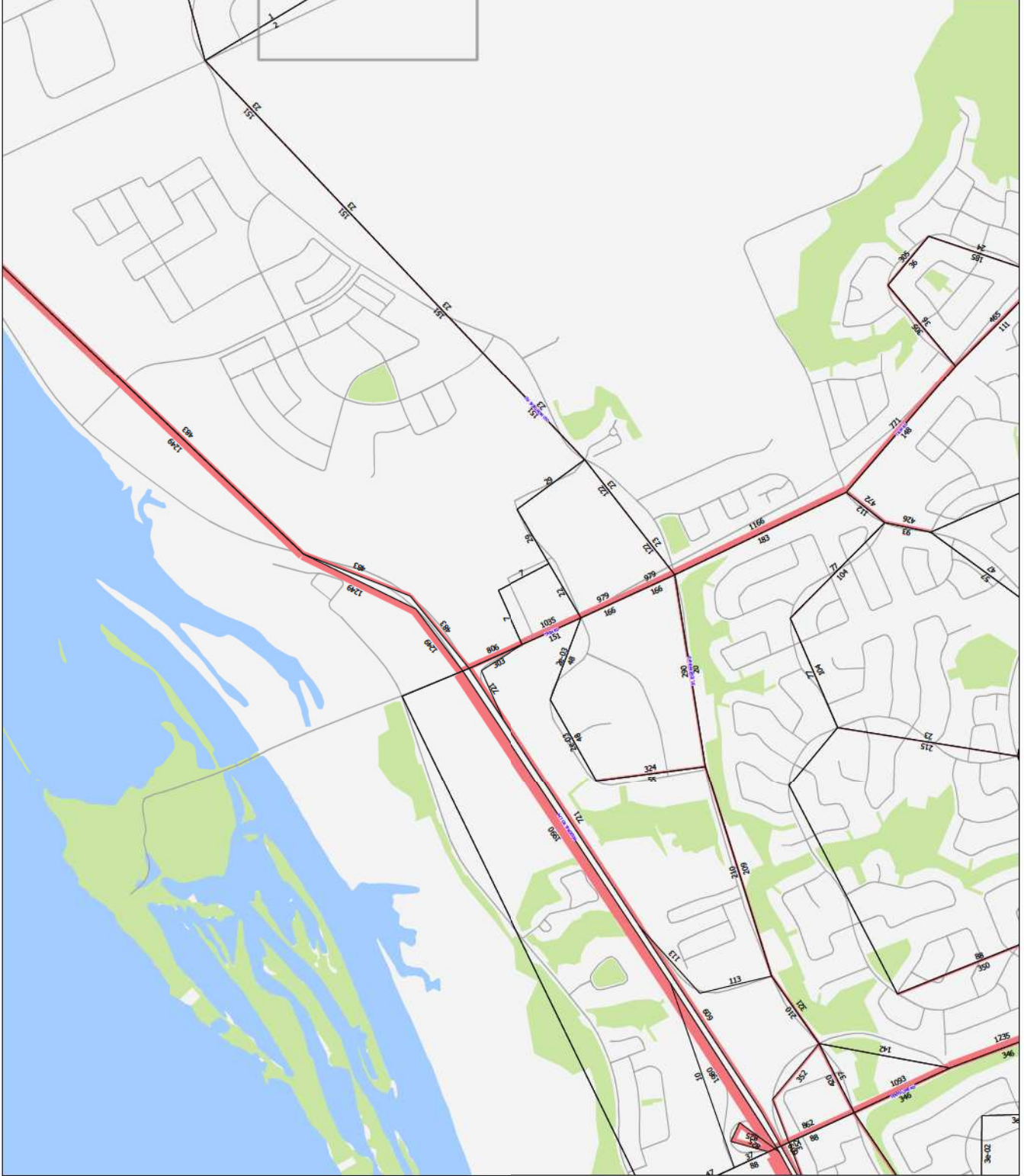

TRANS Regional Model

Version 2.15 - Assigned June 16, 2020

AM Peak Hour Total Traffic Volume Wellington Street Area Growth

2031 Model - Basecase

N/A

User Initials: TIMW
Plot Prepared: August 10, 2020
EMME Scenario: 21711



Legend

AM Peak Hour Total Traffic Volume

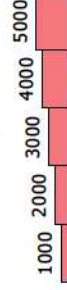

The TRANS model is continuously refined & maintained, and all information is provided in good faith. However, model outputs are provided "as is", and no warranty or guarantee is provided as to the accuracy, reliability or reasonableness of the results. In using this data, you agree to accept any and all risks arising from any incorrect, incomplete, or misleading information.

Recipients are required to use caution and professional judgement in using and interpreting model outputs. In particular, caution should be used when focusing on a geographically limited area (such as a single road or intersection), as the model is primarily designed to simulate regional-scale phenomena and has been calibrated at a regional level.

As general good practice, it is recommended that the user confirm the network coding within the area of interest, and compare base year forecasts against traffic count data to assess the extent to which the model may be over- or under-estimating the travel demand.

Appendix G

Synchro Intersection Worksheets – 2027 Future Background Conditions

MOVEMENT SUMMARY

Site: 101 [Trim-Old Montreal AM FB2027 (Site Folder: General)]

Output produced by SIDRA INTERSECTION Version: 9.1.3.210

Tamarak CCV South
Site Category: (None)
Roundabout

Vehicle Movement Performance													
Mov ID	Turn Class	Demand Flows [Total HV]	Arrival Flows [Total HV]	Deg. Satn	Aver. Delay	Level of Service	95% Back Of Queue [Veh.]	Prop. Que	Eff. Stop Rate	Aver. No. of Cycles	Aver. Speed		
		veh/h %	veh/h %	v/c	sec		[Veh.] [Dist]				km/h		
South: Trim													
1	L2	All MCs	230 2.0 230 2.0	0.599	10.2	LOS B	3.6 25.7	0.46	0.52	0.46	52.0		
2	T1	All MCs	1222 2.0 1222 2.0	0.599	4.6	LOS A	3.7 26.1	0.47	0.50	0.47	53.3		
3	R2	All MCs	109 2.0 109 2.0	0.599	5.0	LOS A	3.7 26.1	0.48	0.49	0.49	53.2		
Approach			1561 2.0 1561 2.0	0.599	5.5	LOS A	3.7 26.1	0.47	0.50	0.47	53.1		
East: Old Montreal													
4	L2	All MCs	238 2.0 238 2.0	0.373	14.6	LOS B	2.0 14.4	0.80	0.90	0.88	47.7		
5	T1	All MCs	283 2.0 283 2.0	0.285	6.8	LOS A	1.7 12.3	0.80	0.67	0.80	52.0		
6	R2	All MCs	241 2.0 241 2.0	0.210	5.6	LOS A	1.1 7.8	0.69	0.68	0.69	52.9		
Approach			762 2.0 762 2.0	0.373	8.9	LOS A	2.0 14.4	0.76	0.75	0.79	50.8		
North: Trim													
7	L2	All MCs	103 2.0 103 2.0	0.246	12.0	LOS B	1.2 8.5	0.65	0.71	0.65	50.4		
8	T1	All MCs	300 2.0 300 2.0	0.246	5.9	LOS A	1.3 9.0	0.64	0.62	0.64	52.4		
9	R2	All MCs	27 2.0 27 2.0	0.246	5.8	LOS A	1.3 9.0	0.64	0.57	0.64	52.5		
Approach			430 2.0 430 2.0	0.246	7.3	LOS A	1.3 9.0	0.64	0.64	0.64	51.9		
West: St Joseph													
10	L2	All MCs	61 2.0 61 2.0	0.061	10.8	LOS B	0.3 1.8	0.50	0.70	0.50	49.5		
11	T1	All MCs	85 2.0 85 2.0	0.061	4.6	LOS A	0.3 2.0	0.49	0.46	0.49	53.5		
12	R2	All MCs	42 20.0 42 20.0	0.033	4.8	LOS A	0.1 1.1	0.43	0.53	0.43	53.4		
Approach			188 6.0 188 6.0	0.061	6.7	LOS A	0.3 2.0	0.48	0.56	0.48	52.1		
All Vehicles			2941 2.3 2941 2.3	0.599	6.7	LOS A	3.7 26.1	0.57	0.59	0.58	52.2		

Site Level of Service (LOS) Method: Delay (SIDRA). Site LOS Method is specified in the Parameter Settings dialog (Options tab).
 Roundabout LOS Method: SIDRA Roundabout LOS.
 Vehicle movement LOS values are based on average delay per movement.
 Intersection and Approach LOS values are based on average delay for all vehicle movements.
 Roundabout Capacity Model: SIDRA Standard.
 Delay Model: SIDRA Standard (Control Delay: Geometric Delay is included).
 Queue Model: SIDRA queue estimation methods are used for Back of Queue and Queue at Start of Gap.
 Gap-Acceptance Capacity Formula: SIDRA Standard (Akçelik M3D).
 HV (%) values are calculated for All Movement Classes of All Heavy Vehicle Model Designation.
 Arrival Flows used in performance calculations are adjusted to include any Initial Queued Demand and Upstream Capacity Constraint effects.

SIDRA INTERSECTION 9.1 | Copyright © 2000-2023 Akcelik and Associates Pty Ltd | sidrasolutions.com
 Organisation: CGH TRANSPORTATION | Licence: NETWORK / FLOATING | Processed: Tuesday, October 22, 2024 11:09:25 AM
 Project: Not Saved

Lanes, Volumes, Timings

1: Trim Rd & St Joseph Blvd/Old Montreal Rd

10/22/2024



Lane Group	EBL	EBT	EBR	WBL	WBT	WBR	NBL	NBT	NBR	SBL	SBT	SBR
Lane Configurations		↕↕	↕		↕↕	↕		↕↕			↕↕	
Traffic Volume (vph)	61	85	42	238	283	241	230	1222	109	103	300	27
Future Volume (vph)	61	85	42	238	283	241	230	1222	109	103	300	27
Satd. Flow (prot)	0	3045	1375	0	3158	1483	0	3235	0	0	3121	0
Fit Permitted		0.980			0.978			0.993			0.988	
Satd. Flow (perm)	0	3045	1375	0	3158	1483	0	3235	0	0	3121	0
Lane Group Flow (vph)	0	146	42	0	521	241	0	1561	0	0	430	0
Sign Control		Yield			Yield			Yield			Yield	

Intersection Summary	
Control Type:	Roundabout
Intersection Capacity Utilization	92.8%
ICU Level of Service	F
Analysis Period (min)	15

HCM 2010 TWSC
2: Aveia Private/Dairy Dr & Old Montreal Rd

10/22/2024

Intersection												
Int Delay, s/veh	0.9											
Movement	EBL	EBT	EBR	WBL	WBT	WBR	NBL	NBT	NBR	SBL	SBT	SBR
Lane Configurations	↔	↔		↔	↔			↔		↔	↔	
Traffic Vol, veh/h	33	167	5	0	622	27	9	7	0	3	0	7
Future Vol, veh/h	33	167	5	0	622	27	9	7	0	3	0	7
Conflicting Peds, #/hr	0	0	1	1	0	0	2	0	0	0	0	2
Sign Control	Free	Free	Free	Free	Free	Free	Stop	Stop	Stop	Stop	Stop	Stop
RT Channelized	-	-	None	-	-	None	-	-	None	-	-	None
Storage Length	55	-	-	70	-	-	-	-	-	30	-	-
Veh in Median Storage, #	-	0	-	-	0	-	-	0	-	-	0	-
Grade, %	-	0	-	-	0	-	-	0	-	-	0	-
Peak Hour Factor	100	100	100	100	100	100	100	100	100	100	100	100
Heavy Vehicles, %	2	10	2	2	3	2	2	2	2	17	2	2
Mvmt Flow	33	167	5	0	622	27	9	7	0	3	0	7

Major/Minor	Major1	Major2	Minor1	Minor2
Conflicting Flow All	649	0	0	173
Stage 1	-	-	-	-
Stage 2	-	-	-	-
Critical Hdwy	4.12	-	-	4.12
Critical Hdwy Stg 1	-	-	-	-
Critical Hdwy Stg 2	-	-	-	-
Follow-up Hdwy	2.218	-	-	2.218
Pot Cap-1 Maneuver	937	-	-	1404
Stage 1	-	-	-	-
Stage 2	-	-	-	-
Platoon blocked, %	-	-	-	-
Mov Cap-1 Maneuver	937	-	-	1403
Mov Cap-2 Maneuver	-	-	-	-
Stage 1	-	-	-	-
Stage 2	-	-	-	-

Approach	EB	WB	NB	SB
HCM Control Delay, s	1.4	0	19.5	14.9
HCM LOS			C	B

Minor Lane/Major Mvmt	NBLn1	EBL	EBT	EBR	WBL	WBT	WBR	SBLn1	SBLn2
Capacity (veh/h)	264	937	-	-	1403	-	-	242	476
HCM Lane V/C Ratio	0.061	0.035	-	-	-	-	-	0.012	0.015
HCM Control Delay (s)	19.5	9	-	-	0	-	-	20.1	12.7
HCM Lane LOS	C	A	-	-	A	-	-	C	B
HCM 95th %tile Q(veh)	0.2	0.1	-	-	0	-	-	0	0

HCM 2010 TWSC
3: Old Montreal Rd & Famille-Laporte Ave

10/22/2024

Intersection									
Int Delay, s/veh	2.5								
Movement	EBL	EBT	WBT	WBR	SBL	SBR			
Lane Configurations	↔	↔	↔		↔	↔			
Traffic Vol, veh/h	51	106	540	9	8	104			
Future Vol, veh/h	51	106	540	9	8	104			
Conflicting Peds, #/hr	0	0	0	0	0	0			
Sign Control	Free	Free	Free	Free	Stop	Stop			
RT Channelized	-	None	-	None	-	None			
Storage Length	155	-	-	-	0	-			
Veh in Median Storage, #	-	0	0	-	0	-			
Grade, %	-	0	0	-	0	-			
Peak Hour Factor	100	100	100	100	100	100			
Heavy Vehicles, %	10	13	2	2	2	8			
Mvmt Flow	51	106	540	9	8	104			

Major/Minor	Major1	Major2	Minor2
Conflicting Flow All	549	0	0
Stage 1	-	-	-
Stage 2	-	-	-
Critical Hdwy	4.2	-	-
Critical Hdwy Stg 1	-	-	-
Critical Hdwy Stg 2	-	-	-
Follow-up Hdwy	2.29	-	-
Pot Cap-1 Maneuver	982	-	-
Stage 1	-	-	-
Stage 2	-	-	-
Platoon blocked, %	-	-	-
Mov Cap-1 Maneuver	982	-	-
Mov Cap-2 Maneuver	-	-	-
Stage 1	-	-	-
Stage 2	-	-	-

Approach	EB	WB	SB
HCM Control Delay, s	2.9	0	14
HCM LOS			B

Minor Lane/Major Mvmt	EBL	EBT	WBT	WBR	SBLn1
Capacity (veh/h)	982	-	-	-	510
HCM Lane V/C Ratio	0.052	-	-	-	0.22
HCM Control Delay (s)	8.9	-	-	-	14
HCM Lane LOS	A	-	-	-	B
HCM 95th %tile Q(veh)	0.2	-	-	-	0.8

HCM 2010 TWSC
4: Old Montreal Rd & Cardinal Creek Dr

10/22/2024

Intersection						
Int Delay, s/veh	0.3					
Movement	EBL	EBT	WBT	WBR	SBL	SBR
Lane Configurations		↕	↕		↕	↕
Traffic Vol, veh/h	11	75	393	8	0	4
Future Vol, veh/h	11	75	393	8	0	4
Conflicting Peds, #/hr	0	0	0	0	0	0
Sign Control	Free	Free	Free	Free	Stop	Stop
RT Channelized	-	None	-	None	-	None
Storage Length	-	-	-	-	0	-
Veh in Median Storage, #	-	0	0	-	0	-
Grade, %	-	0	0	-	0	-
Peak Hour Factor	100	100	100	100	100	100
Heavy Vehicles, %	27	2	2	25	2	75
Mvmt Flow	11	75	393	8	0	4

Major/Minor	Major1	Major2	Minor2
Conflicting Flow All	401	0	494
Stage 1	-	-	397
Stage 2	-	-	97
Critical Hdwy	4.37	-	6.42
Critical Hdwy Stg 1	-	-	5.42
Critical Hdwy Stg 2	-	-	5.42
Follow-up Hdwy	2.443	-	3.518
Pot Cap-1 Maneuver	1034	-	535
Stage 1	-	-	679
Stage 2	-	-	927
Platoon blocked, %	-	-	-
Mov Cap-1 Maneuver	1034	-	529
Mov Cap-2 Maneuver	-	-	529
Stage 1	-	-	672
Stage 2	-	-	927

Approach	EB	WB	SB
HCM Control Delay, s	1.1	0	12
HCM LOS			B

Minor Lane/Major Mvmt	EBL	EBT	WBT	WBR	SBLn1
Capacity (veh/h)	1034	-	-	-	520
HCM Lane V/C Ratio	0.011	-	-	-	0.008
HCM Control Delay (s)	8.5	0	-	-	12
HCM Lane LOS	A	A	-	-	B
HCM 95th %tile Q(veh)	0	-	-	-	0

HCM 2010 TWSC
5: Cox Country Rd/Ted Kelly Ln & Old Montreal Rd

10/22/2024

Intersection												
Int Delay, s/veh	4.5											
Movement	EBL	EBT	EBR	WBL	WBT	WBR	NBL	NBT	NBR	SBL	SBT	SBR
Lane Configurations		↕			↕			↕			↕	
Traffic Vol, veh/h	3	47	25	31	259	2	134	1	15	1	2	8
Future Vol, veh/h	3	47	25	31	259	2	134	1	15	1	2	8
Conflicting Peds, #/hr	0	0	0	0	0	0	0	0	0	0	0	0
Sign Control	Free	Free	Free	Free	Free	Free	Stop	Stop	Stop	Stop	Stop	Stop
RT Channelized	-	-	None	-	-	None	-	-	None	-	-	None
Storage Length	-	-	-	-	-	-	-	-	-	-	-	-
Veh in Median Storage, #	-	0	-	-	0	-	-	0	-	-	0	-
Grade, %	-	0	-	-	0	-	-	0	-	-	0	-
Peak Hour Factor	100	100	100	100	100	100	100	100	100	100	100	100
Heavy Vehicles, %	2	3	2	3	3	2	2	2	7	2	2	2
Mvmt Flow	3	47	25	31	259	2	134	1	15	1	2	8

Major/Minor	Major1	Major2	Minor1	Minor2
Conflicting Flow All	261	0	72	393
Stage 1	-	-	-	66
Stage 2	-	-	-	327
Critical Hdwy	4.12	-	4.13	7.12
Critical Hdwy Stg 1	-	-	-	6.12
Critical Hdwy Stg 2	-	-	-	6.12
Follow-up Hdwy	2.218	-	2.227	3.518
Pot Cap-1 Maneuver	1303	-	1522	566
Stage 1	-	-	-	945
Stage 2	-	-	-	686
Platoon blocked, %	-	-	-	-
Mov Cap-1 Maneuver	1303	-	1522	547
Mov Cap-2 Maneuver	-	-	-	547
Stage 1	-	-	-	943
Stage 2	-	-	-	661

Approach	EB	WB	NB	SB
HCM Control Delay, s	0.3	0.8	13.5	10.3
HCM LOS			B	B

Minor Lane/Major Mvmt	NBLn1	EBL	EBT	EBR	WBL	WBT	WBR	SBLn1
Capacity (veh/h)	573	1303	-	-	1522	-	-	691
HCM Lane V/C Ratio	0.262	0.002	-	-	0.02	-	-	0.016
HCM Control Delay (s)	13.5	7.8	0	-	7.4	0	-	10.3
HCM Lane LOS	B	A	A	-	A	A	-	B
HCM 95th %tile Q(veh)	1	0	-	-	0.1	-	-	0

Intersection						
Int Delay, s/veh	5.1					
Movement	WBL	WBR	NBT	NBR	SBL	SBT
Lane Configurations	↔		↔			↔
Traffic Vol, veh/h	33	94	56	8	9	49
Future Vol, veh/h	33	94	56	8	9	49
Conflicting Peds, #/hr	0	0	0	0	1	0
Sign Control	Stop	Stop	Free	Free	Free	Free
RT Channelized	-	None	-	None	-	None
Storage Length	0	-	-	-	-	-
Veh in Median Storage, #	0	-	0	-	-	0
Grade, %	0	-	0	-	-	0
Peak Hour Factor	100	100	100	100	100	100
Heavy Vehicles, %	6	5	3	2	2	11
Mvmt Flow	33	94	56	8	9	49

Major/Minor	Minor1	Major1	Major2
Conflicting Flow All	128	61	0
Stage 1	61	-	-
Stage 2	67	-	-
Critical Hdwy	6.46	6.25	-
Critical Hdwy Stg 1	5.46	-	-
Critical Hdwy Stg 2	5.46	-	-
Follow-up Hdwy	3,554	3,345	-
Pot Cap-1 Maneuver	857	996	-
Stage 1	952	-	-
Stage 2	946	-	-
Platoon blocked, %	-	-	-
Mov Cap-1 Maneuver	851	995	-
Mov Cap-2 Maneuver	851	-	-
Stage 1	951	-	-
Stage 2	940	-	-

Approach	WB	NB	SB
HCM Control Delay, s	9.4	0	1.1
HCM LOS	A		

Minor Lane/Major Mvmt	NBT	NBRWBLn1	SBL	SBT
Capacity (veh/h)	-	-	953	1536
HCM Lane V/C Ratio	-	-	0.133	0.006
HCM Control Delay (s)	-	-	9.4	7.4
HCM Lane LOS	-	-	A	A
HCM 95th %tile Q(veh)	-	-	0.5	0

MOVEMENT SUMMARY

Site: 101 [Trim-Old Montreal PM FB2027 (Site Folder: General)]

Output produced by SIDRA INTERSECTION Version: 9.1.3.210

Tamarak CCV South
Site Category: (None)
Roundabout

Vehicle Movement Performance													
Mov ID	Turn	Mov Class	Demand Flows [Total HV]	Arrival Flows [Total HV]	Deg. Satn	Aver. Delay	Level of Service	95% Back Of Queue [Veh.]	Prop. Que	Eff. Stop Rate	Aver. No. of Cycles	Aver. Speed	
			veh/h %	veh/h %	v/c	sec		Dist m				km/h	
South: Trim													
1	L2	All MCs	123 2.0	123 2.0	0.435	11.7	LOS B	2.5	18.1	0.70	0.67	0.74	50.9
2	T1	All MCs	490 2.0	490 2.0	0.435	6.2	LOS A	2.5	18.1	0.70	0.69	0.75	52.2
3	R2	All MCs	162 2.0	162 2.0	0.435	6.8	LOS A	2.4	17.1	0.70	0.71	0.76	52.3
Approach			775 2.0	775 2.0	0.435	7.2	LOS A	2.5	18.1	0.70	0.69	0.75	52.0
East: Old Montreal													
4	L2	All MCs	170 2.0	170 2.0	0.175	11.1	LOS B	0.8	6.0	0.58	0.72	0.58	49.2
5	T1	All MCs	186 2.0	186 2.0	0.144	4.8	LOS A	0.7	5.3	0.56	0.47	0.56	53.2
6	R2	All MCs	160 2.0	160 2.0	0.117	4.6	LOS A	0.6	4.0	0.49	0.55	0.49	53.7
Approach			516 2.0	516 2.0	0.175	6.8	LOS A	0.8	6.0	0.54	0.58	0.54	51.9
North: Trim													
7	L2	All MCs	483 2.0	483 2.0	1.007	35.0	LOS D	28.4	202.5	1.00	1.67	2.60	39.0
8	T1	All MCs	1592 2.0	1592 2.0	1.007	27.6	LOS C	30.5	217.2	1.00	1.67	2.55	41.0
9	R2	All MCs	61 2.0	61 2.0	1.007	26.8	LOS C	30.5	217.2	1.00	1.67	2.52	41.4
Approach			2136 2.0	2136 2.0	1.007	29.2	LOS C	30.5	217.2	1.00	1.67	2.56	40.5
West: St Joseph													
10	L2	All MCs	49 2.0	49 2.0	0.431	20.9	LOS C	2.6	18.4	0.94	0.98	1.08	46.0
11	T1	All MCs	297 2.0	297 2.0	0.431	14.0	LOS B	3.5	24.9	0.98	0.95	1.10	48.2
12	R2	All MCs	274 2.0	274 2.0	0.457	11.1	LOS B	3.7	26.5	1.00	0.91	1.12	49.8
Approach			620 2.0	620 2.0	0.457	13.3	LOS B	3.7	26.5	0.99	0.94	1.11	48.7
All Vehicles			4047 2.0	4047 2.0	1.007	19.7	LOS B	30.5	217.2	0.88	1.23	1.73	44.8

Site Level of Service (LOS) Method: Delay (SIDRA). Site LOS Method is specified in the Parameter Settings dialog (Options tab).
 Roundabout LOS Method: SIDRA Roundabout LOS.
 Vehicle movement LOS values are based on average delay per movement.
 Intersection and Approach LOS values are based on average delay for all vehicle movements.
 Roundabout Capacity Model: SIDRA Standard.
 Delay Model: SIDRA Standard (Control Delay: Geometric Delay is included).
 Queue Model: SIDRA queue estimation methods are used for Back of Queue and Queue at Start of Gap.
 Gap-Acceptance Capacity Formula: SIDRA Standard (Akgelik M3D).
 HV (%) values are calculated for All Movement Classes of All Heavy Vehicle Model Designation.
 Arrival Flows used in performance calculations are adjusted to include any Initial Queued Demand and Upstream Capacity Constraint effects.

Lanes, Volumes, Timings

1: Trim Rd & St Joseph Blvd/Old Montreal Rd

10/22/2024

Lane Group	EBL	EBT	EBR	WBL	WBT	WBR	NBL	NBT	NBR	SBL	SBT	SBR
Lane Configurations		↕↕	↕		↕↕	↕		↕↕			↕↕	
Traffic Volume (vph)	49	297	274	170	186	160	123	490	162	483	1592	61
Future Volume (vph)	49	297	274	170	186	160	123	490	162	483	1592	61
Satd. Flow (prot)	0	3292	1483	0	3239	1483	0	3168	0	0	3266	0
Fit Permitted		0.993			0.977			0.992			0.989	
Satd. Flow (perm)	0	3292	1483	0	3239	1483	0	3168	0	0	3266	0
Lane Group Flow (vph)	0	346	274	0	356	160	0	775	0	0	2136	0
Sign Control		Yield			Yield			Yield			Yield	

Intersection Summary

Control Type: Roundabout	
Intersection Capacity Utilization 121.1%	ICU Level of Service H
Analysis Period (min) 15	

HCM 2010 TWSC

2: Aveia Private/Dairy Dr & Old Montreal Rd

10/22/2024

Intersection

Int Delay, s/veh	1.3											
Movement	EBL	EBT	EBR	WBL	WBT	WBR	NBL	NBT	NBR	SBL	SBT	SBR
Lane Configurations	↕	↕		↕	↕			↕		↕	↕	
Traffic Vol, veh/h	6	682	9	1	291	9	4	6	1	22	2	47
Future Vol, veh/h	6	682	9	1	291	9	4	6	1	22	2	47
Conflicting Peds, #/hr	1	0	0	0	0	1	0	0	2	2	0	0
Sign Control	Free	Free	Free	Free	Free	Free	Stop	Stop	Stop	Stop	Stop	Stop
RT Channelized	-	-	None	-	-	None	-	-	None	-	-	None
Storage Length	55	-	-	70	-	-	-	-	-	30	-	-
Veh in Median Storage, #	-	0	-	-	0	-	-	0	-	-	0	-
Grade, %	-	0	-	-	0	-	-	0	-	-	0	-
Peak Hour Factor	100	100	100	100	100	100	100	100	100	100	100	100
Heavy Vehicles, %	33	2	2	2	6	2	2	2	2	2	2	10
Mvmt Flow	6	682	9	1	291	9	4	6	1	22	2	47

Major/Minor	Major1	Major2	Minor1	Minor2
Conflicting Flow All	301	0	691	0
Stage 1	-	-	-	-
Stage 2	-	-	-	-
Critical Hdwy	4.43	-	4.12	-
Critical Hdwy Stg 1	-	-	-	-
Critical Hdwy Stg 2	-	-	-	-
Follow-up Hdwy	2.497	-	2.218	-
Pot Cap-1 Maneuver	1103	-	904	-
Stage 1	-	-	-	-
Stage 2	-	-	-	-
Platoon blocked, %	-	-	-	-
Mov Cap-1 Maneuver	1102	-	904	-
Mov Cap-2 Maneuver	-	-	-	-
Stage 1	-	-	-	-
Stage 2	-	-	-	-

Approach	EB	WB	NB	SB
HCM Control Delay, s	0.1	0	21.3	14.8
HCM LOS			C	B

Minor Lane/Major Mvmt	NBLn1	EBL	EBT	EBR	WBL	WBT	WBR	SBLn1	SBLn2
Capacity (veh/h)	232	1102	-	-	904	-	-	215	668
HCM Lane V/C Ratio	0.047	0.005	-	-	0.001	-	-	0.102	0.073
HCM Control Delay (s)	21.3	8.3	-	-	9	-	-	23.6	10.8
HCM Lane LOS	C	A	-	-	A	-	-	C	B
HCM 95th %tile Q(veh)	0.1	0	-	-	0	-	-	0.3	0.2

Intersection						
Int Delay, s/veh	1.9					
Movement	EBL	EBT	WBT	WBR	SBL	SBR
Lane Configurations	↖	↑	↗		↖	↗
Traffic Vol, veh/h	116	613	225	8	10	74
Future Vol, veh/h	116	613	225	8	10	74
Conflicting Peds, #/hr	0	0	0	0	0	0
Sign Control	Free	Free	Free	Free	Stop	Stop
RT Channelized	-	None	-	None	-	None
Storage Length	155	-	-	-	0	-
Veh in Median Storage, #	-	0	0	-	0	-
Grade, %	-	0	0	-	0	-
Peak Hour Factor	100	100	100	100	100	100
Heavy Vehicles, %	4	2	2	2	2	3
Mvmt Flow	116	613	225	8	10	74

Major/Minor	Major1	Major2	Minor2		
Conflicting Flow All	233	0	0	1074	229
Stage 1	-	-	-	229	-
Stage 2	-	-	-	845	-
Critical Hdwy	4.14	-	-	6.42	6.23
Critical Hdwy Stg 1	-	-	-	5.42	-
Critical Hdwy Stg 2	-	-	-	5.42	-
Follow-up Hdwy	2.236	-	-	3.518	3.327
Pot Cap-1 Maneuver	1323	-	-	243	808
Stage 1	-	-	-	809	-
Stage 2	-	-	-	421	-
Platoon blocked, %	-	-	-	-	-
Mov Cap-1 Maneuver	1323	-	-	222	808
Mov Cap-2 Maneuver	-	-	-	222	-
Stage 1	-	-	-	738	-
Stage 2	-	-	-	421	-

Approach	EB	WB	SB
HCM Control Delay, s	1.3	0	11.8
HCM LOS			B

Minor Lane/Major Mvmt	EBL	EBT	WBT	WBR	SBLn1
Capacity (veh/h)	1323	-	-	-	615
HCM Lane V/C Ratio	0.088	-	-	-	0.137
HCM Control Delay (s)	8	-	-	-	11.8
HCM Lane LOS	A	-	-	-	B
HCM 95th %tile Q(veh)	0.3	-	-	-	0.5

Intersection						
Int Delay, s/veh	0.2					
Movement	EBL	EBT	WBT	WBR	SBL	SBR
Lane Configurations		↖	↗		↖	↗
Traffic Vol, veh/h	10	523	127	1	2	6
Future Vol, veh/h	10	523	127	1	2	6
Conflicting Peds, #/hr	0	0	0	0	0	0
Sign Control	Free	Free	Free	Free	Stop	Stop
RT Channelized	-	None	-	None	-	None
Storage Length	-	-	-	-	0	-
Veh in Median Storage, #	-	0	0	-	0	-
Grade, %	-	0	0	-	0	-
Peak Hour Factor	100	100	100	100	100	100
Heavy Vehicles, %	10	2	2	2	50	17
Mvmt Flow	10	523	127	1	2	6

Major/Minor	Major1	Major2	Minor2		
Conflicting Flow All	128	0	0	671	128
Stage 1	-	-	-	128	-
Stage 2	-	-	-	543	-
Critical Hdwy	4.2	-	-	6.9	6.37
Critical Hdwy Stg 1	-	-	-	5.9	-
Critical Hdwy Stg 2	-	-	-	5.9	-
Follow-up Hdwy	2.29	-	-	3.95	3.453
Pot Cap-1 Maneuver	1410	-	-	356	883
Stage 1	-	-	-	792	-
Stage 2	-	-	-	497	-
Platoon blocked, %	-	-	-	-	-
Mov Cap-1 Maneuver	1410	-	-	352	883
Mov Cap-2 Maneuver	-	-	-	352	-
Stage 1	-	-	-	784	-
Stage 2	-	-	-	497	-

Approach	EB	WB	SB
HCM Control Delay, s	0.1	0	10.7
HCM LOS			B

Minor Lane/Major Mvmt	EBL	EBT	WBT	WBR	SBLn1
Capacity (veh/h)	1410	-	-	-	641
HCM Lane V/C Ratio	0.007	-	-	-	0.012
HCM Control Delay (s)	7.6	0	-	-	10.7
HCM Lane LOS	A	A	-	-	B
HCM 95th %tile Q(veh)	0	-	-	-	0

Intersection												
Int Delay, s/veh	2.1											
Movement	EBL	EBT	EBR	WBL	WBT	WBR	NBL	NBT	NBR	SBL	SBT	SBR
Lane Configurations	↕			↕			↕			↕		
Traffic Vol, veh/h	12	398	115	23	89	1	34	6	39	0	2	5
Future Vol, veh/h	12	398	115	23	89	1	34	6	39	0	2	5
Conflicting Peds, #/hr	0	0	0	0	0	0	0	0	2	0	0	0
Sign Control	Free	Free	Free	Free	Free	Free	Stop	Stop	Stop	Stop	Stop	Stop
RT Channelized	-	-	None	-	-	None	-	-	None	-	-	None
Storage Length	-	-	-	-	-	-	-	-	-	-	-	-
Veh in Median Storage, #	-	0	-	-	0	-	-	0	-	-	0	-
Grade, %	-	0	-	-	0	-	-	0	-	-	0	-
Peak Hour Factor	100	100	100	100	100	100	100	100	100	100	100	100
Heavy Vehicles, %	2	2	3	2	2	2	2	17	3	2	2	2
Mvmt Flow	12	398	115	23	89	1	34	6	39	0	2	5

Major/Minor	Major1			Major2			Minor1			Minor2		
Conflicting Flow All	90	0	0	513	0	0	619	616	458	640	673	90
Stage 1	-	-	-	-	-	-	480	480	-	136	136	-
Stage 2	-	-	-	-	-	-	139	136	-	504	537	-
Critical Hdwy	4.12	-	-	4.12	-	-	7.12	6.67	6.23	7.12	6.52	6.22
Critical Hdwy Stg 1	-	-	-	-	-	-	6.12	5.67	-	6.12	5.52	-
Critical Hdwy Stg 2	-	-	-	-	-	-	6.12	5.67	-	6.12	5.52	-
Follow-up Hdwy	2.218	-	-	2.218	-	-	3.518	4.153	3.327	3.518	4.018	3.318
Pot Cap-1 Maneuver	1505	-	-	1052	-	-	401	387	601	388	377	968
Stage 1	-	-	-	-	-	-	567	530	-	867	784	-
Stage 2	-	-	-	-	-	-	864	756	-	550	523	-
Platoon blocked, %	-	-	-	-	-	-	-	-	-	-	-	-
Mov Cap-1 Maneuver	1505	-	-	1052	-	-	387	374	600	348	364	968
Mov Cap-2 Maneuver	-	-	-	-	-	-	387	374	-	348	364	-
Stage 1	-	-	-	-	-	-	561	524	-	857	766	-
Stage 2	-	-	-	-	-	-	838	739	-	502	517	-

Approach	EB	WB	NB	SB
HCM Control Delay, s	0.2	1.7	14.2	10.5
HCM LOS			B	B

Minor Lane/Major Mvmt	NBLn1	EBL	EBT	EBR	WBL	WBT	WBR	SBLn1
Capacity (veh/h)	468	1505	-	-	1052	-	-	657
HCM Lane V/C Ratio	0.169	0.008	-	-	0.022	-	-	0.011
HCM Control Delay (s)	14.2	7.4	0	-	8.5	0	-	10.5
HCM Lane LOS	B	A	A	-	A	A	-	B
HCM 95th %tile Q(veh)	0.6	0	-	-	0.1	-	-	0

Intersection						
Int Delay, s/veh	3.7					
Movement	WBL	WBR	NBT	NBR	SBL	SBT
Lane Configurations	↕		↕		↕	↕
Traffic Vol, veh/h	21	24	55	29	72	68
Future Vol, veh/h	21	24	55	29	72	68
Conflicting Peds, #/hr	0	0	0	0	0	0
Sign Control	Stop	Stop	Free	Free	Free	Free
RT Channelized	-	None	-	None	-	None
Storage Length	0	-	-	-	-	-
Veh in Median Storage, #	0	-	0	-	-	0
Grade, %	0	-	0	-	-	0
Peak Hour Factor	100	100	100	100	100	100
Heavy Vehicles, %	5	2	3	7	3	3
Mvmt Flow	21	24	55	29	72	68

Major/Minor	Minor1	Major1	Major2			
Conflicting Flow All	282	70	0	0	84	0
Stage 1	70	-	-	-	-	-
Stage 2	212	-	-	-	-	-
Critical Hdwy	6.45	6.22	-	-	4.13	-
Critical Hdwy Stg 1	5.45	-	-	-	-	-
Critical Hdwy Stg 2	5.45	-	-	-	-	-
Follow-up Hdwy	3.545	3.318	-	-	2.227	-
Pot Cap-1 Maneuver	702	993	-	-	1506	-
Stage 1	945	-	-	-	-	-
Stage 2	816	-	-	-	-	-
Platoon blocked, %	-	-	-	-	-	-
Mov Cap-1 Maneuver	667	993	-	-	1506	-
Mov Cap-2 Maneuver	667	-	-	-	-	-
Stage 1	945	-	-	-	-	-
Stage 2	775	-	-	-	-	-

Approach	WB	NB	SB
HCM Control Delay, s	9.7	0	3.9
HCM LOS	A		

Minor Lane/Major Mvmt	NBT	NBR	WBLn1	SBL	SBT
Capacity (veh/h)	-	-	809	1506	-
HCM Lane V/C Ratio	-	-	0.056	0.048	-
HCM Control Delay (s)	-	-	9.7	7.5	0
HCM Lane LOS	-	-	A	A	A
HCM 95th %tile Q(veh)	-	-	0.2	0.2	-

Appendix H

Synchro Intersection Worksheets – 2032 Future Background Conditions

MOVEMENT SUMMARY

Site: 101 [Trim-Old Montreal AM FB2032 (Site Folder: General)]

Output produced by SIDRA INTERSECTION Version: 9.1.3.210

Tamarak CCV South
Site Category: (None)
Roundabout

Vehicle Movement Performance															
Mov ID	Turn Class	Mov Class	Demand Flows		Arrival Flows		Deg. Satn	Aver. Delay	Level of Service	95% Back Of Queue		Prop. Que	Eff. Stop Rate	Aver. No. of Cycles	Aver. Speed
			[Total HV]	%	[Total HV]	%				[Veh.]	[Dist]				
			veh/h	%	veh/h	%	v/c	sec			veh	m	Rate	Cycles	km/h
South: Trim															
1	L2	All MCs	254	2.0	254	2.0	0.704	10.7	LOS B	5.6	39.5	0.54	0.57	0.57	51.7
2	T1	All MCs	1469	2.0	1469	2.0	0.704	5.3	LOS A	5.7	40.2	0.55	0.57	0.59	52.9
3	R2	All MCs	109	2.0	109	2.0	0.704	5.6	LOS A	5.7	40.2	0.57	0.56	0.61	52.7
Approach			1832	2.0	1832	2.0	0.704	6.0	LOS A	5.7	40.2	0.55	0.57	0.59	52.7
East: Old Montreal															
4	L2	All MCs	238	2.0	238	2.0	0.457	17.4	LOS B	2.8	19.6	0.87	0.98	1.06	46.1
5	T1	All MCs	309	2.0	309	2.0	0.380	8.6	LOS A	2.7	19.1	0.92	0.83	0.97	51.4
6	R2	All MCs	241	2.0	241	2.0	0.243	6.2	LOS A	1.4	10.0	0.78	0.75	0.78	52.6
Approach			788	2.0	788	2.0	0.457	10.5	LOS B	2.8	19.6	0.86	0.85	0.94	50.0
North: Trim															
7	L2	All MCs	103	2.0	103	2.0	0.260	12.1	LOS B	1.3	9.1	0.67	0.73	0.67	50.3
8	T1	All MCs	300	2.0	300	2.0	0.260	6.0	LOS A	1.4	9.7	0.67	0.63	0.67	52.2
9	R2	All MCs	30	2.0	30	2.0	0.260	5.9	LOS A	1.4	9.7	0.67	0.59	0.67	52.3
Approach			433	2.0	433	2.0	0.260	7.5	LOS A	1.4	9.7	0.67	0.65	0.67	51.8
West: St Joseph															
10	L2	All MCs	61	2.0	61	2.0	0.062	10.8	LOS B	0.3	1.9	0.51	0.70	0.51	49.5
11	T1	All MCs	85	2.0	85	2.0	0.062	4.6	LOS A	0.3	2.0	0.49	0.46	0.49	53.4
12	R2	All MCs	42	20.0	42	20.0	0.033	4.8	LOS A	0.1	1.1	0.44	0.53	0.44	53.4
Approach			188	6.0	188	6.0	0.062	6.7	LOS A	0.3	2.0	0.48	0.56	0.48	52.1
All Vehicles			3241	2.2	3241	2.2	0.704	7.4	LOS A	5.7	40.2	0.64	0.65	0.68	51.9

Site Level of Service (LOS) Method: Delay (SIDRA). Site LOS Method is specified in the Parameter Settings dialog (Options tab).
 Roundabout LOS Method: SIDRA Roundabout LOS.
 Vehicle movement LOS values are based on average delay per movement.
 Intersection and Approach LOS values are based on average delay for all vehicle movements.
 Roundabout Capacity Model: SIDRA Standard.
 Delay Model: SIDRA Standard (Control Delay: Geometric Delay is included).
 Queue Model: SIDRA queue estimation methods are used for Back of Queue and Queue at Start of Gap.
 Gap-Acceptance Capacity Formula: SIDRA Standard (Akçelik M3D).
 HV (%) values are calculated for All Movement Classes of All Heavy Vehicle Model Designation.
 Arrival Flows used in performance calculations are adjusted to include any Initial Queued Demand and Upstream Capacity Constraint effects.

SIDRA INTERSECTION 9.1 | Copyright © 2000-2023 Akcelik and Associates Pty Ltd | sidrasolutions.com
 Organisation: CGH TRANSPORTATION | Licence: NETWORK / FLOATING | Processed: Tuesday, October 22, 2024 11:09:27 AM
 Project: Not Saved

Lanes, Volumes, Timings

1: Trim Rd & St Joseph Blvd/Old Montreal Rd

10/22/2024



Lane Group	EBL	EBT	EBR	WBL	WBT	WBR	NBL	NBT	NBR	SBL	SBT	SBR
Lane Configurations		↕↕	↕		↕↕	↕		↕↕			↕↕	
Traffic Volume (vph)	61	85	42	238	309	241	254	1469	109	103	300	30
Future Volume (vph)	61	85	42	238	309	241	254	1469	109	103	300	30
Satd. Flow (prot)	0	3045	1375	0	3165	1483	0	3242	0	0	3118	0
Fit Permitted		0.980			0.979			0.993			0.988	
Satd. Flow (perm)	0	3045	1375	0	3165	1483	0	3242	0	0	3118	0
Lane Group Flow (vph)	0	146	42	0	547	241	0	1832	0	0	433	0
Sign Control		Yield			Yield			Yield			Yield	

Intersection Summary	
Control Type:	Roundabout
Intersection Capacity Utilization	101.5%
ICU Level of Service	G
Analysis Period (min)	15

HCM 2010 TWSC
2: Aveia Private/Dairy Dr & Old Montreal Rd

10/22/2024

Intersection												
Int Delay, s/veh	0.9											
Movement	EBL	EBT	EBR	WBL	WBT	WBR	NBL	NBT	NBR	SBL	SBT	SBR
Lane Configurations	↔	↔		↔	↔			↔		↔	↔	
Traffic Vol, veh/h	33	167	5	0	648	27	9	7	0	3	0	7
Future Vol, veh/h	33	167	5	0	648	27	9	7	0	3	0	7
Conflicting Peds, #/hr	0	0	1	1	0	0	2	0	0	0	0	2
Sign Control	Free	Free	Free	Free	Free	Free	Stop	Stop	Stop	Stop	Stop	Stop
RT Channelized	-	-	None	-	-	None	-	-	None	-	-	None
Storage Length	55	-	-	70	-	-	-	-	-	30	-	-
Veh in Median Storage, #	-	0	-	-	0	-	-	0	-	-	0	-
Grade, %	-	0	-	-	0	-	-	0	-	-	0	-
Peak Hour Factor	100	100	100	100	100	100	100	100	100	100	100	100
Heavy Vehicles, %	2	10	2	2	3	2	2	2	2	17	2	2
Mvmt Flow	33	167	5	0	648	27	9	7	0	3	0	7

Major/Minor	Major1	Major2	Minor1	Minor2
Conflicting Flow All	675	0	173	0
Stage 1	-	-	-	-
Stage 2	-	-	-	-
Critical Hdwy	4.12	-	4.12	-
Critical Hdwy Stg 1	-	-	-	-
Critical Hdwy Stg 2	-	-	-	-
Follow-up Hdwy	2.218	-	2.218	-
Pot Cap-1 Maneuver	916	-	1404	-
Stage 1	-	-	-	-
Stage 2	-	-	-	-
Platoon blocked, %	-	-	-	-
Mov Cap-1 Maneuver	916	-	1403	-
Mov Cap-2 Maneuver	-	-	-	-
Stage 1	-	-	-	-
Stage 2	-	-	-	-

Approach	EB	WB	NB	SB
HCM Control Delay, s	1.5	0	20.1	15.2
HCM LOS			C	C

Minor Lane/Major Mvmt	NBLn1	EBL	EBT	EBR	WBL	WBT	WBR	SBLn1	SBLn2
Capacity (veh/h)	254	916	-	-	1403	-	-	233	460
HCM Lane V/C Ratio	0.063	0.036	-	-	-	-	-	0.013	0.015
HCM Control Delay (s)	20.1	9.1	-	-	0	-	-	20.7	12.9
HCM Lane LOS	C	A	-	-	A	-	-	C	B
HCM 95th %tile Q(veh)	0.2	0.1	-	-	0	-	-	0	0

HCM 2010 TWSC
3: Old Montreal Rd & Famille-Laporte Ave

10/22/2024

Intersection						
Int Delay, s/veh	2.5					
Movement	EBL	EBT	WBT	WBR	SBL	SBR
Lane Configurations	↔	↔	↔		↔	↔
Traffic Vol, veh/h	51	106	566	9	8	104
Future Vol, veh/h	51	106	566	9	8	104
Conflicting Peds, #/hr	0	0	0	0	0	0
Sign Control	Free	Free	Free	Free	Stop	Stop
RT Channelized	-	None	-	None	-	None
Storage Length	155	-	-	-	0	-
Veh in Median Storage, #	-	0	0	-	0	-
Grade, %	-	0	0	-	0	-
Peak Hour Factor	100	100	100	100	100	100
Heavy Vehicles, %	10	13	2	2	2	8
Mvmt Flow	51	106	566	9	8	104

Major/Minor	Major1	Major2	Minor2
Conflicting Flow All	575	0	0
Stage 1	-	-	-
Stage 2	-	-	-
Critical Hdwy	4.2	-	-
Critical Hdwy Stg 1	-	-	-
Critical Hdwy Stg 2	-	-	-
Follow-up Hdwy	2.29	-	-
Pot Cap-1 Maneuver	960	-	-
Stage 1	-	-	-
Stage 2	-	-	-
Platoon blocked, %	-	-	-
Mov Cap-1 Maneuver	960	-	-
Mov Cap-2 Maneuver	-	-	-
Stage 1	-	-	-
Stage 2	-	-	-

Approach	EB	WB	SB
HCM Control Delay, s	2.9	0	14.5
HCM LOS			B

Minor Lane/Major Mvmt	EBL	EBT	WBT	WBR	SBLn1
Capacity (veh/h)	960	-	-	-	492
HCM Lane V/C Ratio	0.053	-	-	-	0.228
HCM Control Delay (s)	9	-	-	-	14.5
HCM Lane LOS	A	-	-	-	B
HCM 95th %tile Q(veh)	0.2	-	-	-	0.9

HCM 2010 TWSC
4: Old Montreal Rd & Cardinal Creek Dr

10/22/2024

Intersection						
Int Delay, s/veh	0.3					
Movement	EBL	EBT	WBT	WBR	SBL	SBR
Lane Configurations		↕	↕		↕	
Traffic Vol, veh/h	11	75	419	8	0	4
Future Vol, veh/h	11	75	419	8	0	4
Conflicting Peds, #/hr	0	0	0	0	0	0
Sign Control	Free	Free	Free	Free	Stop	Stop
RT Channelized	-	None	-	None	-	None
Storage Length	-	-	-	-	0	-
Veh in Median Storage, #	-	0	0	-	0	-
Grade, %	-	0	0	-	0	-
Peak Hour Factor	100	100	100	100	100	100
Heavy Vehicles, %	27	2	2	25	2	75
Mvmt Flow	11	75	419	8	0	4

Major/Minor	Major1	Major2	Minor2
Conflicting Flow All	427	0	520
Stage 1	-	-	423
Stage 2	-	-	97
Critical Hdwy	4.37	-	6.42
Critical Hdwy Stg 1	-	-	5.42
Critical Hdwy Stg 2	-	-	5.42
Follow-up Hdwy	2.443	-	3.975
Pot Cap-1 Maneuver	1011	-	516
Stage 1	-	-	661
Stage 2	-	-	927
Platoon blocked, %	-	-	-
Mov Cap-1 Maneuver	1011	-	510
Mov Cap-2 Maneuver	-	-	510
Stage 1	-	-	654
Stage 2	-	-	927

Approach	EB	WB	SB
HCM Control Delay, s	1.1	0	12.2
HCM LOS			B

Minor Lane/Major Mvmt	EBL	EBT	WBT	WBR	SBLn1
Capacity (veh/h)	1011	-	-	-	501
HCM Lane V/C Ratio	0.011	-	-	-	0.008
HCM Control Delay (s)	8.6	0	-	-	12.2
HCM Lane LOS	A	A	-	-	B
HCM 95th %tile Q(veh)	0	-	-	-	0

HCM 2010 TWSC
5: Cox Country Rd/Ted Kelly Ln & Old Montreal Rd

10/22/2024

Intersection												
Int Delay, s/veh	4.4											
Movement	EBL	EBT	EBR	WBL	WBT	WBR	NBL	NBT	NBR	SBL	SBT	SBR
Lane Configurations		↕			↕			↕			↕	
Traffic Vol, veh/h	3	47	25	31	285	2	134	1	15	1	2	8
Future Vol, veh/h	3	47	25	31	285	2	134	1	15	1	2	8
Conflicting Peds, #/hr	0	0	0	0	0	0	0	0	0	0	0	0
Sign Control	Free	Free	Free	Free	Free	Free	Stop	Stop	Stop	Stop	Stop	Stop
RT Channelized	-	-	None	-	-	None	-	-	None	-	-	None
Storage Length	-	-	-	-	-	-	-	-	-	-	-	-
Veh in Median Storage, #	-	0	-	-	0	-	-	0	-	-	0	-
Grade, %	-	0	-	-	0	-	-	0	-	-	0	-
Peak Hour Factor	100	100	100	100	100	100	100	100	100	100	100	100
Heavy Vehicles, %	2	3	2	3	3	2	2	2	7	2	2	2
Mvmt Flow	3	47	25	31	285	2	134	1	15	1	2	8

Major/Minor	Major1	Major2	Minor1	Minor2
Conflicting Flow All	287	0	72	419
Stage 1	-	-	-	66
Stage 2	-	-	-	353
Critical Hdwy	4.12	-	4.13	7.12
Critical Hdwy Stg 1	-	-	-	6.12
Critical Hdwy Stg 2	-	-	-	6.12
Follow-up Hdwy	2.218	-	2.227	4.018
Pot Cap-1 Maneuver	1275	-	1522	544
Stage 1	-	-	-	945
Stage 2	-	-	-	664
Platoon blocked, %	-	-	-	-
Mov Cap-1 Maneuver	1275	-	1522	526
Mov Cap-2 Maneuver	-	-	-	526
Stage 1	-	-	-	943
Stage 2	-	-	-	639

Approach	EB	WB	NB	SB
HCM Control Delay, s	0.3	0.7	13.9	10.5
HCM LOS			B	B

Minor Lane/Major Mvmt	NBLn1	EBL	EBT	EBR	WBL	WBT	WBR	SBLn1
Capacity (veh/h)	552	1275	-	-	1522	-	-	667
HCM Lane V/C Ratio	0.272	0.002	-	-	0.02	-	-	0.016
HCM Control Delay (s)	13.9	7.8	0	-	7.4	0	-	10.5
HCM Lane LOS	B	A	A	-	A	A	-	B
HCM 95th %tile Q(veh)	1.1	0	-	-	0.1	-	-	0.1

Intersection						
Int Delay, s/veh	5.1					
Movement	WBL	WBR	NBT	NBR	SBL	SBT
Lane Configurations	↔		↔			↔
Traffic Vol, veh/h	33	94	56	8	9	49
Future Vol, veh/h	33	94	56	8	9	49
Conflicting Peds, #/hr	0	0	0	0	1	0
Sign Control	Stop	Stop	Free	Free	Free	Free
RT Channelized	-	None	-	None	-	None
Storage Length	0	-	-	-	-	-
Veh in Median Storage, #	0	-	0	-	-	0
Grade, %	0	-	0	-	-	0
Peak Hour Factor	100	100	100	100	100	100
Heavy Vehicles, %	6	5	3	2	2	11
Mvmt Flow	33	94	56	8	9	49

Major/Minor	Minor1	Major1	Major2
Conflicting Flow All	128	61	0
Stage 1	61	-	-
Stage 2	67	-	-
Critical Hdwy	6.46	6.25	-
Critical Hdwy Stg 1	5.46	-	-
Critical Hdwy Stg 2	5.46	-	-
Follow-up Hdwy	3,554	3,345	-
Pot Cap-1 Maneuver	857	996	-
Stage 1	952	-	-
Stage 2	946	-	-
Platoon blocked, %	-	-	-
Mov Cap-1 Maneuver	851	995	-
Mov Cap-2 Maneuver	851	-	-
Stage 1	951	-	-
Stage 2	940	-	-

Approach	WB	NB	SB
HCM Control Delay, s	9.4	0	1.1
HCM LOS	A		

Minor Lane/Major Mvmt	NBT	NBRWBLn1	SBL	SBT
Capacity (veh/h)	-	-	953	1536
HCM Lane V/C Ratio	-	-	0.133	0.006
HCM Control Delay (s)	-	-	9.4	7.4
HCM Lane LOS	-	-	A	A
HCM 95th %tile Q(veh)	-	-	0.5	0

MOVEMENT SUMMARY

Site: 101 [Trim-Old Montreal PM FB2032 (Site Folder: General)]

Output produced by SIDRA INTERSECTION Version: 9.1.3.210

Tamarak CCV South
Site Category: (None)
Roundabout

Vehicle Movement Performance													
Mov ID	Turn	Mov Class	Demand Flows [Total HV]	Arrival Flows [Total HV]	Deg. Satn	Aver. Delay	Level of Service	95% Back Of Queue [Veh.]	Prop. Que	Eff. Stop Rate	Aver. No. of Cycles	Aver. Speed	
			veh/h %	veh/h %	v/c	sec		Dist m				km/h	
South: Trim													
1	L2	All MCs	123 2.0	123 2.0	0.499	12.5	LOS B	3.1	22.0	0.77	0.77	0.89	50.5
2	T1	All MCs	490 2.0	490 2.0	0.499	7.2	LOS A	3.1	22.0	0.77	0.79	0.89	51.7
3	R2	All MCs	162 2.0	162 2.0	0.499	7.9	LOS A	2.8	20.2	0.77	0.83	0.90	51.9
Approach			775 2.0	775 2.0	0.499	8.2	LOS A	3.1	22.0	0.77	0.80	0.89	51.5
East: Old Montreal													
4	L2	All MCs	170 2.0	170 2.0	0.178	11.1	LOS B	0.9	6.2	0.59	0.73	0.59	49.2
5	T1	All MCs	186 2.0	186 2.0	0.147	4.8	LOS A	0.8	5.6	0.57	0.48	0.57	53.1
6	R2	All MCs	160 2.0	160 2.0	0.119	4.6	LOS A	0.6	4.2	0.50	0.55	0.50	53.6
Approach			516 2.0	516 2.0	0.178	6.8	LOS A	0.9	6.2	0.56	0.58	0.56	51.8
North: Trim													
7	L2	All MCs	483 2.0	483 2.0	1.160	90.5	LOS F	64.5	459.4	1.00	2.89	5.49	24.9
8	T1	All MCs	1914 2.0	1914 2.0	1.160	83.7	LOS F	73.3	521.8	1.00	3.00	5.59	25.5
9	R2	All MCs	61 2.0	61 2.0	1.160	83.2	LOS F	73.3	521.8	1.00	3.05	5.64	25.6
Approach			2458 2.0	2458 2.0	1.160	85.0	LOS F	73.3	521.8	1.00	2.98	5.57	25.4
West: St Joseph													
10	L2	All MCs	54 2.0	54 2.0	0.858	39.4	LOS D	7.3	52.0	1.00	1.24	1.81	37.8
11	T1	All MCs	627 2.0	627 2.0	0.858	33.9	LOS C	10.7	76.4	1.00	1.29	1.90	38.5
12	R2	All MCs	303 2.0	303 2.0	0.529	12.9	LOS B	4.5	32.0	1.00	0.96	1.20	48.6
Approach			984 2.0	984 2.0	0.858	27.8	LOS C	10.7	76.4	1.00	1.19	1.68	41.0
All Vehicles			4733 2.0	4733 2.0	1.160	52.0	LOS E	73.3	521.8	0.91	1.99	3.45	32.4

Site Level of Service (LOS) Method: Delay (SIDRA). Site LOS Method is specified in the Parameter Settings dialog (Options tab).
 Roundabout LOS Method: SIDRA Roundabout LOS.
 Vehicle movement LOS values are based on average delay per movement.
 Intersection and Approach LOS values are based on average delay for all vehicle movements.
 Roundabout Capacity Model: SIDRA Standard.
 Delay Model: SIDRA Standard (Control Delay: Geometric Delay is included).
 Queue Model: SIDRA queue estimation methods are used for Back of Queue and Queue at Start of Gap.
 Gap-Acceptance Capacity Formula: SIDRA Standard (Akgelik M3D).
 HV (%) values are calculated for All Movement Classes of All Heavy Vehicle Model Designation.
 Arrival Flows used in performance calculations are adjusted to include any Initial Queued Demand and Upstream Capacity Constraint effects.

Lanes, Volumes, Timings

1: Trim Rd & St Joseph Blvd/Old Montreal Rd

10/22/2024

Lane Group	EBL	EBT	EBR	WBL	WBT	WBR	NBL	NBT	NBR	SBL	SBT	SBR
Lane Configurations		↕↕	↕		↕↕	↕		↕↕			↕↕	
Traffic Volume (vph)	54	627	303	170	186	160	123	490	162	483	1914	61
Future Volume (vph)	54	627	303	170	186	160	123	490	162	483	1914	61
Satd. Flow (prot)	0	3302	1483	0	3239	1483	0	3168	0	0	3269	0
Fit Permitted		0.996			0.977			0.992			0.990	
Satd. Flow (perm)	0	3302	1483	0	3239	1483	0	3168	0	0	3269	0
Lane Group Flow (vph)	0	681	303	0	356	160	0	775	0	0	2458	0
Sign Control		Yield			Yield			Yield			Yield	

Intersection Summary

Control Type: Roundabout	
Intersection Capacity Utilization 140.3%	ICU Level of Service H
Analysis Period (min) 15	

HCM 2010 TWSC

2: Aveia Private/Dairy Dr & Old Montreal Rd

10/22/2024

Intersection

Int Delay, s/veh	1.3											
Movement	EBL	EBT	EBR	WBL	WBT	WBR	NBL	NBT	NBR	SBL	SBT	SBR
Lane Configurations	↕	↕		↕	↕			↕		↕	↕	
Traffic Vol, veh/h	6	1012	9	1	291	9	4	6	1	22	2	47
Future Vol, veh/h	6	1012	9	1	291	9	4	6	1	22	2	47
Conflicting Peds, #/hr	1	0	0	0	0	1	0	0	2	2	0	0
Sign Control	Free	Free	Free	Free	Free	Free	Stop	Stop	Stop	Stop	Stop	Stop
RT Channelized	-	-	None	-	-	None	-	-	None	-	-	None
Storage Length	55	-	-	70	-	-	-	-	-	30	-	-
Veh in Median Storage, #	-	0	-	-	0	-	-	0	-	-	0	-
Grade, %	-	0	-	-	0	-	-	0	-	-	0	-
Peak Hour Factor	100	100	100	100	100	100	100	100	100	100	100	100
Heavy Vehicles, %	33	2	2	2	6	2	2	2	2	2	2	10
Mvmt Flow	6	1012	9	1	291	9	4	6	1	22	2	47

Major/Minor	Major1	Major2	Minor1	Minor2
Conflicting Flow All	301	0	1021	0
Stage 1	-	-	-	-
Stage 2	-	-	-	-
Critical Hdwy	4.43	-	4.12	-
Critical Hdwy Stg 1	-	-	-	-
Critical Hdwy Stg 2	-	-	-	-
Follow-up Hdwy	2.497	-	2.218	-
Pot Cap-1 Maneuver	1103	-	680	-
Stage 1	-	-	-	-
Stage 2	-	-	-	-
Platoon blocked, %	-	-	-	-
Mov Cap-1 Maneuver	1102	-	680	-
Mov Cap-2 Maneuver	-	-	-	-
Stage 1	-	-	-	-
Stage 2	-	-	-	-

Approach	EB	WB	NB	SB
HCM Control Delay, s	0	0	32.3	20
HCM LOS			D	C

Minor Lane/Major Mvmt	NBLn1	EBL	EBT	EBR	WBL	WBT	WBR	SBLn1	SBLn2
Capacity (veh/h)	143	1102	-	-	680	-	-	126	628
HCM Lane V/C Ratio	0.077	0.005	-	-	0.001	-	-	0.175	0.078
HCM Control Delay (s)	32.3	8.3	-	-	10.3	-	-	39.5	11.2
HCM Lane LOS	D	A	-	-	B	-	-	E	B
HCM 95th %tile Q(veh)	0.2	0	-	-	0	-	-	0.6	0.3

HCM 2010 TWSC
3: Old Montreal Rd & Famille-Laporte Ave

10/22/2024

Intersection						
Int Delay, s/veh	1.5					
Movement	EBL	EBT	WBT	WBR	SBL	SBR
Lane Configurations	↔	↑	↔		↔	↔
Traffic Vol, veh/h	116	943	225	8	10	74
Future Vol, veh/h	116	943	225	8	10	74
Conflicting Peds, #/hr	0	0	0	0	0	0
Sign Control	Free	Free	Free	Free	Stop	Stop
RT Channelized	-	None	-	None	-	None
Storage Length	155	-	-	-	0	-
Veh in Median Storage, #	-	0	0	-	0	-
Grade, %	-	0	0	-	0	-
Peak Hour Factor	100	100	100	100	100	100
Heavy Vehicles, %	4	2	2	2	2	3
Mvmt Flow	116	943	225	8	10	74

Major/Minor	Major1	Major2	Minor2		
Conflicting Flow All	233	0	0	1404	229
Stage 1	-	-	-	229	-
Stage 2	-	-	-	1175	-
Critical Hdwy	4.14	-	-	6.42	6.23
Critical Hdwy Stg 1	-	-	-	5.42	-
Critical Hdwy Stg 2	-	-	-	5.42	-
Follow-up Hdwy	2.236	-	-	3.518	3.327
Pot Cap-1 Maneuver	1323	-	-	154	808
Stage 1	-	-	-	809	-
Stage 2	-	-	-	293	-
Platoon blocked, %	-	-	-	-	-
Mov Cap-1 Maneuver	1323	-	-	140	808
Mov Cap-2 Maneuver	-	-	-	140	-
Stage 1	-	-	-	738	-
Stage 2	-	-	-	293	-

Approach	EB	WB	SB
HCM Control Delay, s	0.9	0	13.3
HCM LOS			B

Minor Lane/Major Mvmt	EBL	EBT	WBT	WBR	SBLn1
Capacity (veh/h)	1323	-	-	-	515
HCM Lane V/C Ratio	0.088	-	-	-	0.163
HCM Control Delay (s)	8	-	-	-	13.3
HCM Lane LOS	A	-	-	-	B
HCM 95th %tile Q(veh)	0.3	-	-	-	0.6

HCM 2010 TWSC
4: Old Montreal Rd & Cardinal Creek Dr

10/22/2024

Intersection						
Int Delay, s/veh	0.2					
Movement	EBL	EBT	WBT	WBR	SBL	SBR
Lane Configurations		↔	↔		↔	↔
Traffic Vol, veh/h	10	563	127	1	2	6
Future Vol, veh/h	10	563	127	1	2	6
Conflicting Peds, #/hr	0	0	0	0	0	0
Sign Control	Free	Free	Free	Free	Stop	Stop
RT Channelized	-	None	-	None	-	None
Storage Length	-	-	-	-	0	-
Veh in Median Storage, #	-	0	0	-	0	-
Grade, %	-	0	0	-	0	-
Peak Hour Factor	100	100	100	100	100	100
Heavy Vehicles, %	10	2	2	2	50	17
Mvmt Flow	10	563	127	1	2	6

Major/Minor	Major1	Major2	Minor2		
Conflicting Flow All	128	0	0	711	128
Stage 1	-	-	-	128	-
Stage 2	-	-	-	583	-
Critical Hdwy	4.2	-	-	6.9	6.37
Critical Hdwy Stg 1	-	-	-	5.9	-
Critical Hdwy Stg 2	-	-	-	5.9	-
Follow-up Hdwy	2.29	-	-	3.95	3.453
Pot Cap-1 Maneuver	1410	-	-	336	883
Stage 1	-	-	-	792	-
Stage 2	-	-	-	475	-
Platoon blocked, %	-	-	-	-	-
Mov Cap-1 Maneuver	1410	-	-	333	883
Mov Cap-2 Maneuver	-	-	-	333	-
Stage 1	-	-	-	784	-
Stage 2	-	-	-	475	-

Approach	EB	WB	SB
HCM Control Delay, s	0.1	0	10.8
HCM LOS			B

Minor Lane/Major Mvmt	EBL	EBT	WBT	WBR	SBLn1
Capacity (veh/h)	1410	-	-	-	625
HCM Lane V/C Ratio	0.007	-	-	-	0.013
HCM Control Delay (s)	7.6	0	-	-	10.8
HCM Lane LOS	A	A	-	-	B
HCM 95th %tile Q(veh)	0	-	-	-	0

Intersection												
Int Delay, s/veh	2.1											
Movement	EBL	EBT	EBR	WBL	WBT	WBR	NBL	NBT	NBR	SBL	SBT	SBR
Lane Configurations	↕			↕			↕			↕		
Traffic Vol, veh/h	12	438	115	23	89	1	34	6	39	0	2	5
Future Vol, veh/h	12	438	115	23	89	1	34	6	39	0	2	5
Conflicting Peds, #/hr	0	0	0	0	0	0	0	0	2	0	0	0
Sign Control	Free	Free	Free	Free	Free	Free	Stop	Stop	Stop	Stop	Stop	Stop
RT Channelized	-	-	None	-	-	None	-	-	None	-	-	None
Storage Length	-	-	-	-	-	-	-	-	-	-	-	-
Veh in Median Storage, #	-	0	-	-	0	-	-	0	-	-	0	-
Grade, %	-	0	-	-	0	-	-	0	-	-	0	-
Peak Hour Factor	100	100	100	100	100	100	100	100	100	100	100	100
Heavy Vehicles, %	2	2	3	2	2	2	2	17	3	2	2	2
Mvmt Flow	12	438	115	23	89	1	34	6	39	0	2	5

Major/Minor	Major1			Major2			Minor1			Minor2		
Conflicting Flow All	90	0	0	553	0	0	659	656	498	680	713	90
Stage 1	-	-	-	-	-	-	520	520	-	136	136	-
Stage 2	-	-	-	-	-	-	139	136	-	544	577	-
Critical Hdwy	4.12	-	-	4.12	-	-	7.12	6.67	6.23	7.12	6.52	6.22
Critical Hdwy Stg 1	-	-	-	-	-	-	6.12	5.67	-	6.12	5.52	-
Critical Hdwy Stg 2	-	-	-	-	-	-	6.12	5.67	-	6.12	5.52	-
Follow-up Hdwy	2.218	-	-	2.218	-	-	3.518	4.153	3.327	3.518	4.018	3.318
Pot Cap-1 Maneuver	1505	-	-	1017	-	-	377	367	570	365	357	968
Stage 1	-	-	-	-	-	-	539	508	-	867	784	-
Stage 2	-	-	-	-	-	-	864	756	-	523	502	-
Platoon blocked, %	-	-	-	-	-	-	-	-	-	-	-	-
Mov Cap-1 Maneuver	1505	-	-	1017	-	-	363	354	569	326	344	968
Mov Cap-2 Maneuver	-	-	-	-	-	-	363	354	-	326	344	-
Stage 1	-	-	-	-	-	-	533	502	-	857	765	-
Stage 2	-	-	-	-	-	-	837	738	-	475	496	-

Approach	EB	WB	NB	SB
HCM Control Delay, s	0.2	1.8	14.9	10.7
HCM LOS			B	B

Minor Lane/Major Mvmt	NBLn1	EBL	EBT	EBR	WBL	WBT	WBR	SBLn1
Capacity (veh/h)	441	1505	-	-	1017	-	-	638
HCM Lane V/C Ratio	0.179	0.008	-	-	0.023	-	-	0.011
HCM Control Delay (s)	14.9	7.4	0	-	8.6	0	-	10.7
HCM Lane LOS	B	A	A	-	A	A	-	B
HCM 95th %tile Q(veh)	0.6	0	-	-	0.1	-	-	0

Intersection						
Int Delay, s/veh	3.7					
Movement	WBL	WBR	NBT	NBR	SBL	SBT
Lane Configurations	↕		↕		↕	↕
Traffic Vol, veh/h	21	24	55	29	72	68
Future Vol, veh/h	21	24	55	29	72	68
Conflicting Peds, #/hr	0	0	0	0	0	0
Sign Control	Stop	Stop	Free	Free	Free	Free
RT Channelized	-	None	-	None	-	None
Storage Length	0	-	-	-	-	-
Veh in Median Storage, #	0	-	0	-	-	0
Grade, %	0	-	0	-	-	0
Peak Hour Factor	100	100	100	100	100	100
Heavy Vehicles, %	5	2	3	7	3	3
Mvmt Flow	21	24	55	29	72	68

Major/Minor	Minor1	Major1	Major2			
Conflicting Flow All	282	70	0	0	84	0
Stage 1	70	-	-	-	-	-
Stage 2	212	-	-	-	-	-
Critical Hdwy	6.45	6.22	-	-	4.13	-
Critical Hdwy Stg 1	5.45	-	-	-	-	-
Critical Hdwy Stg 2	5.45	-	-	-	-	-
Follow-up Hdwy	3.545	3.318	-	-	2.227	-
Pot Cap-1 Maneuver	702	993	-	-	1506	-
Stage 1	945	-	-	-	-	-
Stage 2	816	-	-	-	-	-
Platoon blocked, %	-	-	-	-	-	-
Mov Cap-1 Maneuver	667	993	-	-	1506	-
Mov Cap-2 Maneuver	667	-	-	-	-	-
Stage 1	945	-	-	-	-	-
Stage 2	775	-	-	-	-	-

Approach	WB	NB	SB
HCM Control Delay, s	9.7	0	3.9
HCM LOS	A		

Minor Lane/Major Mvmt	NBT	NBR	WBLn1	SBL	SBT
Capacity (veh/h)	-	-	809	1506	-
HCM Lane V/C Ratio	-	-	0.056	0.048	-
HCM Control Delay (s)	-	-	9.7	7.5	0
HCM Lane LOS	-	-	A	A	A
HCM 95th %tile Q(veh)	-	-	0.2	0.2	-

Appendix I

MMLOS Analysis

Multi-Modal Level of Service - Segments Form

Consultant	CGH Transportation Inc.
Scenario	Existing/Future
Comments	

Project	1296 & 1400 Old Montreal Road
Date	10/22/2024

1296 & 1400 Old Montreal Road
10/22/2024

SEGMENTS			Old Montreal Road (Existing)	Old Montreal Road (Future)	Cox Country Road
			1	1	2
Pedestrian	Sidewalk Width	-	no sidewalk	≥ 2 m	no sidewalk
	Boulevard Width		n/a	> 2 m	n/a
	Avg Daily Curb Lane Traffic Volume		> 3000	> 3000	≤ 3000
	Operating Speed		> 60 km/h	> 60 km/h	> 60 km/h
	On-Street Parking		no	no	no
	Exposure to Traffic PLoS		F	D	F
	Effective Sidewalk Width				
	Pedestrian Volume				
Crowding PLoS	-	-	-		
Level of Service	-	-	-		
Bicycle	Type of Cycling Facility	A	Mixed Traffic	Physically Separated	Mixed Traffic
	Number of Travel Lanes		2-3 lanes total		2-3 lanes total
	Operating Speed		≥ 60 km/h		≥ 60 km/h
	# of Lanes & Operating Speed LoS		F	-	F
	Bike Lane (+ Parking Lane) Width				
	Bike Lane Width LoS		-	-	-
	Bike Lane Blockages				
	Blockage LoS		-	-	-
	Median Refuge Width (no median = < 1.8 m)				
	No. of Lanes at Unsignalized Crossing				
Sidestreet Operating Speed					
Unsignalized Crossing - Lowest LoS	-	A	-		
Level of Service	-	A	-		
Transit	Facility Type	A		Segregated ROW	
	Friction or Ratio Transit:Posted Speed				
Level of Service	-	A	-		
Truck	Truck Lane Width	D	≤ 3.3 m	≤ 3.5 m	
	Travel Lanes per Direction		1	1	
	Level of Service		D	C	-

Appendix J

Signal Warrants

St No.1 @ Old Montreal
FT2027

Justification #7

Justification	Description	Minimum Requirement		Minimum Requirement		Compliance		Entire %	Signal
		1 Lane Highway		2 or More Lanes		Sectional			
		Free Flow	Restr. Flow	Free Flow	Restr. Flow	Numerical	%		
1. Minimum Vehicular Volume	A. Vehicle volume, all approaches (average hour)	480	720	600	900	441	92%	70%	No
	B. Vehicle volume, along minor streets (average hour)	120	170	120	170	84	70%		
2. Delay to Cross Traffic	A. Vehicle volumes, major street (average hour)	480	720	600	900	357	74%	74%	No
	B. Combined vehicle and pedestrian volume crossing artery from minor streets (average hour)	50	75	50	75	80	160%		

- Notes
1. Refer to OTM Book 12, pg 92, Mar 2012
 2. Lowest section percentage governs justification
 3. Average hourly volumes estimated from peak hour volumes, $AHV = PM/2$ or $(AM + PM) / 4$, including amplification factors
 4. T-intersection factor corrected, applies only to 1B

St No.1 @ Old Montreal
FT2032

Justification #7

Justification	Description	Minimum Requirement		Minimum Requirement		Compliance		Entire %	Signal
		1 Lane Highway		2 or More Lanes		Sectional			
		Free Flow	Restr. Flow	Free Flow	Restr. Flow	Numerical	%		
1. Minimum Vehicular Volume	A. Vehicle volume, all approaches (average hour)	480	720	600	900	458	95%	70%	No
	B. Vehicle volume, along minor streets (average hour)	120	170	120	170	84	70%		
2. Delay to Cross Traffic	A. Vehicle volumes, major street (average hour)	480	720	600	900	373	78%	78%	No
	B. Combined vehicle and pedestrian volume crossing artery from minor streets (average hour)	50	75	50	75	80	160%		

- Notes
1. Refer to OTM Book 12, pg 92, Mar 2012
 2. Lowest section percentage governs justification
 3. Average hourly volumes estimated from peak hour volumes, $AHV = PM/2$ or $(AM + PM) / 4$, including amplification factors
 4. T-intersection factor corrected, applies only to 1B

Cox Country @ St No.15
FT2027

Justification #7

Justification	Description	Minimum Requirement		Minimum Requirement		Compliance		Entire %	Signal
		1 Lane Highway		2 or More Lanes		Sectional			
		Free Flow	Restr. Flow	Free Flow	Restr. Flow	Numerical	%		
1. Minimum Vehicular Volume	A. Vehicle volume, all approaches (average hour)	480	720	600	900	130	27%	15%	No
	B. Vehicle volume, along minor streets (average hour)	120	170	120	170	18	15%		
2. Delay to Cross Traffic	A. Vehicle volumes, major street (average hour)	480	720	600	900	117	24%	6%	No
	B. Combined vehicle and pedestrian volume crossing artery from minor streets (average hour)	50	75	50	75	3	6%		

- Notes
1. Refer to OTM Book 12, pg 92, Mar 2012
 2. Lowest section percentage governs justification
 3. Average hourly volumes estimated from peak hour volumes, $AHV = PM/2$ or $(AM + PM) / 4$, including amplification factors
 4. T-intersection factor corrected, applies only to 1B

Cox Country @ St No.15
FT2032

Justification #7

Justification	Description	Minimum Requirement		Minimum Requirement		Compliance		Entire %	Signal
		1 Lane Highway		2 or More Lanes		Sectional			
		Free Flow	Restr. Flow	Free Flow	Restr. Flow	Numerical	%		
1. Minimum Vehicular Volume	A. Vehicle volume, all approaches (average hour)	480	720	600	900	130	27%	15%	No
	B. Vehicle volume, along minor streets (average hour)	120	170	120	170	18	15%		
2. Delay to Cross Traffic	A. Vehicle volumes, major street (average hour)	480	720	600	900	117	24%	6%	No
	B. Combined vehicle and pedestrian volume crossing artery from minor streets (average hour)	50	75	50	75	3	6%		

- Notes
1. Refer to OTM Book 12, pg 92, Mar 2012
 2. Lowest section percentage governs justification
 3. Average hourly volumes estimated from peak hour volumes, $AHV = PM/2$ or $(AM + PM) / 4$, including amplification factors
 4. T-intersection factor corrected, applies only to 1B

Appendix K

Synchro Intersection Worksheets – 2027 Future Total Conditions

MOVEMENT SUMMARY

Site: 101 [Trim-Old Montreal AM FT2027 (Site Folder: General)]

Output produced by SIDRA INTERSECTION Version: 9.1.3.210

Tamarak CCV South
Site Category: (None)
Roundabout

Vehicle Movement Performance													
Mov ID	Turn Class	Demand Flows [Total HV]	Arrival Flows [Total HV]	Deg. Satn	Aver. Delay	Level of Service	95% Back Of Queue [Veh.]	Prop. Que. Dist [m]	Prop. Que.	Eff. Stop Rate	Aver. No. of Cycles	Aver. Speed	
		veh/h %	veh/h %	v/c	sec							km/h	
South: Trim													
1	L2	All MCs	230 2.0 230 2.0	0.632	10.8	LOS B	4.4 31.1	0.54	0.58	0.57	51.6		
2	T1	All MCs	1222 2.0 1222 2.0	0.632	5.3	LOS A	4.4 31.2	0.55	0.58	0.59	52.9		
3	R2	All MCs	114 2.0 114 2.0	0.632	5.7	LOS A	4.4 31.2	0.56	0.57	0.61	52.8		
Approach			1566 2.0 1566 2.0	0.632	6.2	LOS A	4.4 31.2	0.55	0.58	0.59	52.7		
East: Old Montreal													
4	L2	All MCs	249 2.0 249 2.0	0.408	14.9	LOS B	2.3 16.5	0.82	0.92	0.94	47.5		
5	T1	All MCs	305 2.0 305 2.0	0.322	6.9	LOS A	2.0 14.5	0.83	0.68	0.83	51.8		
6	R2	All MCs	395 2.0 395 2.0	0.358	5.8	LOS A	2.1 14.7	0.75	0.70	0.75	52.7		
Approach			949 2.0 949 2.0	0.408	8.6	LOS A	2.3 16.5	0.80	0.75	0.83	50.9		
North: Trim													
7	L2	All MCs	169 2.0 169 2.0	0.292	12.2	LOS B	1.5 10.3	0.67	0.76	0.67	49.7		
8	T1	All MCs	300 2.0 300 2.0	0.292	6.0	LOS A	1.5 11.0	0.67	0.62	0.67	52.3		
9	R2	All MCs	27 2.0 27 2.0	0.292	5.9	LOS A	1.5 11.0	0.66	0.59	0.66	52.3		
Approach			496 2.0 496 2.0	0.292	8.1	LOS A	1.5 11.0	0.67	0.66	0.67	51.4		
West: St Joseph													
10	L2	All MCs	61 2.0 61 2.0	0.068	11.0	LOS B	0.3 2.1	0.54	0.71	0.54	49.6		
11	T1	All MCs	94 2.0 94 2.0	0.068	4.8	LOS A	0.3 2.3	0.52	0.48	0.52	53.2		
12	R2	All MCs	42 20.0 42 20.0	0.033	4.7	LOS A	0.1 1.1	0.43	0.54	0.43	53.4		
Approach			197 5.8 197 5.8	0.068	6.7	LOS A	0.3 2.3	0.51	0.56	0.51	52.1		
All Vehicles			3208 2.2 3208 2.2	0.632	7.2	LOS A	4.4 31.2	0.64	0.64	0.67	51.9		

Site Level of Service (LOS) Method: Delay (SIDRA). Site LOS Method is specified in the Parameter Settings dialog (Options tab).
 Roundabout LOS Method: SIDRA Roundabout LOS.
 Vehicle movement LOS values are based on average delay per movement.
 Intersection and Approach LOS values are based on average delay for all vehicle movements.
 Roundabout Capacity Model: SIDRA Standard.
 Delay Model: SIDRA Standard (Control Delay: Geometric Delay is included).
 Queue Model: SIDRA queue estimation methods are used for Back of Queue and Queue at Start of Gap.
 Gap-Acceptance Capacity Formula: SIDRA Standard (Akçelik M3D).
 HV (%) values are calculated for All Movement Classes of All Heavy Vehicle Model Designation.
 Arrival Flows used in performance calculations are adjusted to include any Initial Queued Demand and Upstream Capacity Constraint effects.

SIDRA INTERSECTION 9.1 | Copyright © 2000-2023 Akcelik and Associates Pty Ltd | sidrasolutions.com
 Organisation: CGH TRANSPORTATION | Licence: NETWORK / FLOATING | Processed: Tuesday, October 22, 2024 11:09:28 AM
 Project: Not Saved

Lanes, Volumes, Timings

1: Trim Rd & St Joseph Blvd/Old Montreal Rd

10/22/2024



Lane Group	EBL	EBT	EBR	WBL	WBT	WBR	NBL	NBT	NBR	SBL	SBT	SBR
Lane Configurations		↕↕	↕		↕↕	↕		↕↕			↕↕	
Traffic Volume (vph)	61	94	42	249	305	395	230	1222	114	169	300	27
Future Volume (vph)	61	94	42	249	305	395	230	1222	114	169	300	27
Satd. Flow (prot)	0	3050	1375	0	3159	1483	0	3231	0	0	3117	0
Fit Permitted		0.981			0.978			0.993			0.983	
Satd. Flow (perm)	0	3050	1375	0	3159	1483	0	3231	0	0	3117	0
Lane Group Flow (vph)	0	155	42	0	554	395	0	1566	0	0	496	0
Sign Control		Yield			Yield			Yield			Yield	

Intersection Summary

Control Type: Roundabout

Intersection Capacity Utilization 96.2%

ICU Level of Service F

Analysis Period (min) 15

HCM 2010 TWSC
2: Aveia Private/Dairy Dr & Old Montreal Rd

10/22/2024

Intersection												
Int Delay, s/veh	0.8											
Movement	EBL	EBT	EBR	WBL	WBT	WBR	NBL	NBT	NBR	SBL	SBT	SBR
Lane Configurations	↔	↔		↔	↔			↔		↔	↔	
Traffic Vol, veh/h	33	247	5	0	809	27	9	7	0	3	0	7
Future Vol, veh/h	33	247	5	0	809	27	9	7	0	3	0	7
Conflicting Peds, #/hr	0	0	1	1	0	0	2	0	0	0	0	2
Sign Control	Free	Free	Free	Free	Free	Free	Stop	Stop	Stop	Stop	Stop	Stop
RT Channelized	-	-	None	-	-	None	-	-	None	-	-	None
Storage Length	55	-	-	70	-	-	-	-	-	30	-	-
Veh in Median Storage, #	-	0	-	-	0	-	-	0	-	-	0	-
Grade, %	-	0	-	-	0	-	-	0	-	-	0	-
Peak Hour Factor	100	100	100	100	100	100	100	100	100	100	100	100
Heavy Vehicles, %	2	10	2	2	3	2	2	2	2	17	2	2
Mvmt Flow	33	247	5	0	809	27	9	7	0	3	0	7

Major/Minor	Major1	Major2	Minor1	Minor2
Conflicting Flow All	836	0	0	253
Stage 1	-	-	-	-
Stage 2	-	-	-	-
Critical Hdwy	4.12	-	-	4.12
Critical Hdwy Stg 1	-	-	-	-
Critical Hdwy Stg 2	-	-	-	-
Follow-up Hdwy	2.218	-	-	2.218
Pot Cap-1 Maneuver	798	-	-	1312
Stage 1	-	-	-	-
Stage 2	-	-	-	-
Platoon blocked, %	-	-	-	-
Mov Cap-1 Maneuver	798	-	-	1311
Mov Cap-2 Maneuver	-	-	-	-
Stage 1	-	-	-	-
Stage 2	-	-	-	-

Approach	EB	WB	NB	SB
HCM Control Delay, s	1.1	0	27.4	19
HCM LOS			D	C

Minor Lane/Major Mvmt	NBLn1	EBL	EBT	EBR	WBL	WBT	WBR	SBLn1	SBLn2
Capacity (veh/h)	177	798	-	-	1311	-	-	156	371
HCM Lane V/C Ratio	0.09	0.041	-	-	-	-	-	0.019	0.019
HCM Control Delay (s)	27.4	9.7	-	-	0	-	-	28.5	14.9
HCM Lane LOS	D	A	-	-	A	-	-	D	B
HCM 95th %tile Q(veh)	0.3	0.1	-	-	0	-	-	0.1	0.1

HCM 2010 TWSC
3: Old Montreal Rd & Famille-Laporte Ave

10/22/2024

Intersection						
Int Delay, s/veh	2.3					
Movement	EBL	EBT	WBT	WBR	SBL	SBR
Lane Configurations	↔	↔	↔		↔	↔
Traffic Vol, veh/h	51	186	727	9	8	104
Future Vol, veh/h	51	186	727	9	8	104
Conflicting Peds, #/hr	0	0	0	0	0	0
Sign Control	Free	Free	Free	Free	Stop	Stop
RT Channelized	-	None	-	None	-	None
Storage Length	155	-	-	-	0	-
Veh in Median Storage, #	-	0	0	-	0	-
Grade, %	-	0	0	-	0	-
Peak Hour Factor	100	100	100	100	100	100
Heavy Vehicles, %	10	13	2	2	2	8
Mvmt Flow	51	186	727	9	8	104

Major/Minor	Major1	Major2	Minor2
Conflicting Flow All	736	0	0
Stage 1	-	-	-
Stage 2	-	-	-
Critical Hdwy	4.2	-	-
Critical Hdwy Stg 1	-	-	-
Critical Hdwy Stg 2	-	-	-
Follow-up Hdwy	2.29	-	-
Pot Cap-1 Maneuver	834	-	-
Stage 1	-	-	-
Stage 2	-	-	-
Platoon blocked, %	-	-	-
Mov Cap-1 Maneuver	834	-	-
Mov Cap-2 Maneuver	-	-	-
Stage 1	-	-	-
Stage 2	-	-	-

Approach	EB	WB	SB
HCM Control Delay, s	2.1	0	17.8
HCM LOS			C

Minor Lane/Major Mvmt	EBL	EBT	WBT	WBR	SBLn1
Capacity (veh/h)	834	-	-	-	392
HCM Lane V/C Ratio	0.061	-	-	-	0.286
HCM Control Delay (s)	9.6	-	-	-	17.8
HCM Lane LOS	A	-	-	-	C
HCM 95th %tile Q(veh)	0.2	-	-	-	1.2

HCM 2010 TWSC
4: No.1/Cardinal Creek Dr & Old Montreal Rd

10/22/2024

Intersection												
Int Delay, s/veh	4.6											
Movement	EBL	EBT	EBR	WBL	WBT	WBR	NBL	NBT	NBR	SBL	SBT	SBR
Lane Configurations	↖	↑	↗	↖	↑	↗		↕		↕		
Traffic Vol, veh/h	11	75	80	2	393	8	187	0	4	0	0	4
Future Vol, veh/h	11	75	80	2	393	8	187	0	4	0	0	4
Conflicting Peds, #/hr	0	0	0	0	0	0	0	0	0	0	0	0
Sign Control	Free	Free	Free	Free	Free	Free	Stop	Stop	Stop	Stop	Stop	Stop
RT Channelized	-	-	None	-	-	None	-	-	None	-	-	None
Storage Length	50	-	70	37.5	-	-	-	-	-	-	-	-
Veh in Median Storage, #	-	0	-	-	0	-	-	0	-	-	0	-
Grade, %	-	0	-	-	0	-	-	0	-	-	0	-
Peak Hour Factor	100	100	100	100	100	100	100	100	100	100	100	100
Heavy Vehicles, %	27	2	2	2	2	25	2	2	2	2	2	75
Mvmt Flow	11	75	80	2	393	8	187	0	4	0	0	4

Major/Minor	Major1			Major2			Minor1			Minor2		
Conflicting Flow All	401	0	0	155	0	0	500	502	75	540	578	397
Stage 1	-	-	-	-	-	-	97	97	-	401	401	-
Stage 2	-	-	-	-	-	-	403	405	-	139	177	-
Critical Hdwy	4.37	-	-	4.12	-	-	7.12	6.52	6.22	7.12	6.52	6.95
Critical Hdwy Stg 1	-	-	-	-	-	-	6.12	5.52	-	6.12	5.52	-
Critical Hdwy Stg 2	-	-	-	-	-	-	6.12	5.52	-	6.12	5.52	-
Follow-up Hdwy	2.443	-	-	2.218	-	-	3.518	4.018	3.318	3.518	4.018	3.975
Pot Cap-1 Maneuver	1034	-	-	1425	-	-	481	471	986	453	427	520
Stage 1	-	-	-	-	-	-	910	815	-	626	601	-
Stage 2	-	-	-	-	-	-	624	598	-	864	753	-
Platoon blocked, %	-	-	-	-	-	-	-	-	-	-	-	-
Mov Cap-1 Maneuver	1034	-	-	1425	-	-	473	465	986	447	422	520
Mov Cap-2 Maneuver	-	-	-	-	-	-	473	465	-	447	422	-
Stage 1	-	-	-	-	-	-	900	806	-	619	600	-
Stage 2	-	-	-	-	-	-	618	597	-	851	745	-

Approach	EB	WB	NB	SB
HCM Control Delay, s	0.6	0	17.5	12
HCM LOS			C	B

Minor Lane/Major Mvmt	NBLn1	EBL	EBT	EBR	WBL	WBT	WBR	SBLn1
Capacity (veh/h)	478	1034	-	-	1425	-	-	520
HCM Lane V/C Ratio	0.4	0.011	-	-	0.001	-	-	0.008
HCM Control Delay (s)	17.5	8.5	-	-	7.5	-	-	12
HCM Lane LOS	C	A	-	-	A	-	-	B
HCM 95th %tile Q(veh)	1.9	0	-	-	0	-	-	0

HCM 2010 TWSC
5: Cox Country Rd/Ted Kelly Ln & Old Montreal Rd

10/22/2024

Intersection												
Int Delay, s/veh	4.7											
Movement	EBL	EBT	EBR	WBL	WBT	WBR	NBL	NBT	NBR	SBL	SBT	SBR
Lane Configurations		↕			↕			↕			↕	
Traffic Vol, veh/h	3	51	25	34	261	2	134	1	22	1	2	8
Future Vol, veh/h	3	51	25	34	261	2	134	1	22	1	2	8
Conflicting Peds, #/hr	0	0	0	0	0	0	0	0	0	0	0	0
Sign Control	Free	Free	Free	Free	Free	Free	Stop	Stop	Stop	Stop	Stop	Stop
RT Channelized	-	-	None	-	-	None	-	-	None	-	-	None
Storage Length	-	-	-	-	-	-	-	-	-	-	-	-
Veh in Median Storage, #	-	0	-	-	0	-	-	0	-	-	0	-
Grade, %	-	0	-	-	0	-	-	0	-	-	0	-
Peak Hour Factor	100	100	100	100	100	100	100	100	100	100	100	100
Heavy Vehicles, %	2	3	2	3	3	2	2	2	7	2	2	2
Mvmt Flow	3	51	25	34	261	2	134	1	22	1	2	8

Major/Minor	Major1			Major2			Minor1			Minor2		
Conflicting Flow All	263	0	0	76	0	0	405	401	64	411	412	262
Stage 1	-	-	-	-	-	-	70	70	-	330	330	-
Stage 2	-	-	-	-	-	-	335	331	-	81	82	-
Critical Hdwy	4.12	-	-	4.13	-	-	7.12	6.52	6.27	7.12	6.52	6.22
Critical Hdwy Stg 1	-	-	-	-	-	-	6.12	5.52	-	6.12	5.52	-
Critical Hdwy Stg 2	-	-	-	-	-	-	6.12	5.52	-	6.12	5.52	-
Follow-up Hdwy	2.218	-	-	2.227	-	-	3.518	4.018	3.363	3.518	4.018	3.318
Pot Cap-1 Maneuver	1301	-	-	1517	-	-	556	538	986	551	530	777
Stage 1	-	-	-	-	-	-	940	837	-	683	646	-
Stage 2	-	-	-	-	-	-	679	645	-	927	827	-
Platoon blocked, %	-	-	-	-	-	-	-	-	-	-	-	-
Mov Cap-1 Maneuver	1301	-	-	1517	-	-	537	523	986	526	515	777
Mov Cap-2 Maneuver	-	-	-	-	-	-	537	523	-	526	515	-
Stage 1	-	-	-	-	-	-	938	835	-	682	629	-
Stage 2	-	-	-	-	-	-	652	628	-	903	825	-

Approach	EB	WB	NB	SB
HCM Control Delay, s	0.3	0.9	13.6	10.3
HCM LOS			B	B

Minor Lane/Major Mvmt	NBLn1	EBL	EBT	EBR	WBL	WBT	WBR	SBLn1
Capacity (veh/h)	573	1301	-	-	1517	-	-	684
HCM Lane V/C Ratio	0.274	0.002	-	-	0.022	-	-	0.016
HCM Control Delay (s)	13.6	7.8	0	-	7.4	0	-	10.3
HCM Lane LOS	B	A	A	-	A	A	-	B
HCM 95th %tile Q(veh)	1.1	0	-	-	0.1	-	-	0

Intersection						
Int Delay, s/veh	4.5					
Movement	WBL	WBR	NBT	NBR	SBL	SBT
Lane Configurations	↔		↔			↔
Traffic Vol, veh/h	33	94	65	8	9	71
Future Vol, veh/h	33	94	65	8	9	71
Conflicting Peds, #/hr	0	0	0	0	1	0
Sign Control	Stop	Stop	Free	Free	Free	Free
RT Channelized	-	None	-	None	-	None
Storage Length	0	-	-	-	-	-
Veh in Median Storage, #	0	-	0	-	-	0
Grade, %	0	-	0	-	-	0
Peak Hour Factor	100	100	100	100	100	100
Heavy Vehicles, %	6	5	3	2	2	11
Mvmt Flow	33	94	65	8	9	71

Major/Minor	Minor1	Major1	Major2
Conflicting Flow All	159	70	0 0 74 0
Stage 1	70	-	- - - -
Stage 2	89	-	- - - -
Critical Hdwy	6.46	6.25	- - 4.12 -
Critical Hdwy Stg 1	5.46	-	- - - -
Critical Hdwy Stg 2	5.46	-	- - - -
Follow-up Hdwy	3,554	3,345	- - 2,218 -
Pot Cap-1 Maneuver	823	984	- - 1526 -
Stage 1	943	-	- - - -
Stage 2	924	-	- - - -
Platoon blocked, %	-	-	- - - -
Mov Cap-1 Maneuver	817	983	- - 1525 -
Mov Cap-2 Maneuver	817	-	- - - -
Stage 1	942	-	- - - -
Stage 2	918	-	- - - -

Approach	WB	NB	SB
HCM Control Delay, s	9.5	0	0.8
HCM LOS	A		

Minor Lane/Major Mvmt	NBT	NBRWBLn1	SBL	SBT
Capacity (veh/h)	-	- 934	1525	-
HCM Lane V/C Ratio	-	- 0.136	0.006	-
HCM Control Delay (s)	-	- 9.5	7.4	0
HCM Lane LOS	-	- A	A	A
HCM 95th %tile Q(veh)	-	- 0.5	0	-

Intersection						
Int Delay, s/veh	1.3					
Movement	EBL	EBR	NBL	NBT	SBT	SBR
Lane Configurations	↔			↔	↔	
Traffic Vol, veh/h	7	22	9	150	58	3
Future Vol, veh/h	7	22	9	150	58	3
Conflicting Peds, #/hr	0	0	0	0	0	0
Sign Control	Stop	Stop	Free	Free	Free	Free
RT Channelized	-	None	-	None	-	None
Storage Length	0	-	-	-	-	-
Veh in Median Storage, #	0	-	-	0	0	-
Grade, %	0	-	-	0	0	-
Peak Hour Factor	100	100	100	100	100	100
Heavy Vehicles, %	2	2	2	2	2	2
Mvmt Flow	7	22	9	150	58	3

Major/Minor	Minor2	Major1	Major2
Conflicting Flow All	228	60	61 0 - 0
Stage 1	60	-	- - - -
Stage 2	168	-	- - - -
Critical Hdwy	6.42	6.22	4.12 - - -
Critical Hdwy Stg 1	5.42	-	- - - -
Critical Hdwy Stg 2	5.42	-	- - - -
Follow-up Hdwy	3,518	3,318	2,218 - - -
Pot Cap-1 Maneuver	760	1005	1542 - - -
Stage 1	963	-	- - - -
Stage 2	862	-	- - - -
Platoon blocked, %	-	-	- - - -
Mov Cap-1 Maneuver	755	1005	1542 - - -
Mov Cap-2 Maneuver	755	-	- - - -
Stage 1	957	-	- - - -
Stage 2	862	-	- - - -

Approach	EB	NB	SB
HCM Control Delay, s	9	0.4	0
HCM LOS	A		

Minor Lane/Major Mvmt	NBL	NBT EBLn1	SBT	SBR
Capacity (veh/h)	1542	- 931	-	-
HCM Lane V/C Ratio	0.006	- 0.031	-	-
HCM Control Delay (s)	7.3	0	9	-
HCM Lane LOS	A	A	A	-
HCM 95th %tile Q(veh)	0	- 0.1	-	-

MOVEMENT SUMMARY

Site: 101 [Trim-Old Montreal PM FT2027 (Site Folder: General)]

Output produced by SIDRA INTERSECTION Version: 9.1.3.210

Tamarak CCV South
Site Category: (None)
Roundabout

Vehicle Movement Performance															
Mov ID	Turn Class	Mov Class	Demand Flows		Arrival Flows		Deg. Satn	Aver. Delay	Level of Service	95% Back Of Queue		Prop. Que	Eff. Stop Rate	Aver. No. of Cycles	Aver. Speed
			[Total HV] veh/h	%	[Total HV] veh/h	%				[Veh.] veh	[Dist] m				
South: Trim															
1	L2	All MCs	123	2.0	123	2.0	0.493	12.6	LOS B	3.2	23.0	0.78	0.76	0.88	50.5
2	T1	All MCs	490	2.0	490	2.0	0.493	7.2	LOS A	3.2	23.0	0.78	0.78	0.88	51.7
3	R2	All MCs	173	2.0	173	2.0	0.493	7.9	LOS A	3.0	21.3	0.77	0.82	0.89	51.9
Approach			786	2.0	786	2.0	0.493	8.2	LOS A	3.2	23.0	0.78	0.79	0.88	51.5
East: Old Montreal															
4	L2	All MCs	178	2.0	178	2.0	0.186	11.1	LOS B	0.9	6.6	0.60	0.73	0.60	49.2
5	T1	All MCs	201	2.0	201	2.0	0.158	4.8	LOS A	0.9	6.1	0.57	0.48	0.57	53.1
6	R2	All MCs	268	2.0	268	2.0	0.198	4.6	LOS A	1.0	7.4	0.52	0.56	0.52	53.5
Approach			647	2.0	647	2.0	0.198	6.5	LOS A	1.0	7.4	0.56	0.58	0.56	52.1
North: Trim															
7	L2	All MCs	641	2.0	641	2.0	1.097	65.1	LOS E	47.1	335.5	1.00	2.37	4.30	29.7
8	T1	All MCs	1592	2.0	1592	2.0	1.097	57.9	LOS E	52.8	375.9	1.00	2.44	4.35	30.8
9	R2	All MCs	61	2.0	61	2.0	1.097	57.5	LOS E	52.8	375.9	1.00	2.46	4.37	31.0
Approach			2294	2.0	2294	2.0	1.097	59.9	LOS E	52.8	375.9	1.00	2.42	4.34	30.5
West: St Joseph															
10	L2	All MCs	49	2.0	49	2.0	0.458	21.2	LOS C	2.7	19.6	0.94	0.99	1.11	45.9
11	T1	All MCs	320	2.0	320	2.0	0.458	14.4	LOS B	3.7	26.5	0.98	0.97	1.13	47.9
12	R2	All MCs	274	2.0	274	2.0	0.433	10.1	LOS B	3.4	24.4	1.00	0.88	1.09	50.5
Approach			643	2.0	643	2.0	0.458	13.1	LOS B	3.7	26.5	0.99	0.93	1.11	48.8
All Vehicles			4370	2.0	4370	2.0	1.097	35.8	LOS D	52.8	375.9	0.89	1.64	2.68	37.6

Site Level of Service (LOS) Method: Delay (SIDRA). Site LOS Method is specified in the Parameter Settings dialog (Options tab).
 Roundabout LOS Method: SIDRA Roundabout LOS.
 Vehicle movement LOS values are based on average delay per movement.
 Intersection and Approach LOS values are based on average delay for all vehicle movements.
 Roundabout Capacity Model: SIDRA Standard.
 Delay Model: SIDRA Standard (Control Delay: Geometric Delay is included).
 Queue Model: SIDRA queue estimation methods are used for Back of Queue and Queue at Start of Gap.
 Gap-Acceptance Capacity Formula: SIDRA Standard (Akçelik M3D).
 HV (%) values are calculated for All Movement Classes of All Heavy Vehicle Model Designation.
 Arrival Flows used in performance calculations are adjusted to include any Initial Queued Demand and Upstream Capacity Constraint effects.

SIDRA INTERSECTION 9.1 | Copyright © 2000-2023 Akcelik and Associates Pty Ltd | sidrasolutions.com
 Organisation: CGH TRANSPORTATION | Licence: NETWORK / FLOATING | Processed: Tuesday, October 22, 2024 11:09:28 AM
 Project: Not Saved

Lanes, Volumes, Timings

1: Trim Rd & St Joseph Blvd/Old Montreal Rd

10/22/2024

Lane Group	EBL	EBT	EBR	WBL	WBT	WBR	NBL	NBT	NBR	SBL	SBT	SBR
Lane Configurations		↕↕	↕		↕↕	↕		↕↕			↕↕	
Traffic Volume (vph)	49	320	274	178	201	268	123	490	173	641	1592	61
Future Volume (vph)	49	320	274	178	201	268	123	490	173	641	1592	61
Satd. Flow (prot)	0	3292	1483	0	3239	1483	0	3161	0	0	3256	0
Fit Permitted		0.993			0.977			0.992			0.986	
Satd. Flow (perm)	0	3292	1483	0	3239	1483	0	3161	0	0	3256	0
Lane Group Flow (vph)	0	369	274	0	379	268	0	786	0	0	2294	0
Sign Control		Yield			Yield			Yield			Yield	
Intersection Summary												
Control Type: Roundabout												
Intersection Capacity Utilization 127.6% ICU Level of Service H												
Analysis Period (min) 15												

HCM 2010 TWSC
2: Aveia Private/Dairy Dr & Old Montreal Rd

10/22/2024

Intersection												
Int Delay, s/veh	1.4											
Movement	EBL	EBT	EBR	WBL	WBT	WBR	NBL	NBT	NBR	SBL	SBT	SBR
Lane Configurations	↔	↔		↔	↔			↔		↔	↔	
Traffic Vol, veh/h	6	874	9	1	422	9	4	6	1	22	2	47
Future Vol, veh/h	6	874	9	1	422	9	4	6	1	22	2	47
Conflicting Peds, #/hr	1	0	0	0	0	1	0	0	2	2	0	0
Sign Control	Free	Free	Free	Free	Free	Free	Stop	Stop	Stop	Stop	Stop	Stop
RT Channelized	-	-	None	-	-	None	-	-	None	-	-	None
Storage Length	55	-	-	70	-	-	-	-	-	30	-	-
Veh in Median Storage, #	-	0	-	-	0	-	-	0	-	-	0	-
Grade, %	-	0	-	-	0	-	-	0	-	-	0	-
Peak Hour Factor	100	100	100	100	100	100	100	100	100	100	100	100
Heavy Vehicles, %	33	2	2	2	6	2	2	2	2	2	2	10
Mvmt Flow	6	874	9	1	422	9	4	6	1	22	2	47

Major/Minor	Major1	Major2	Minor1	Minor2
Conflicting Flow All	432	0	883	0
Stage 1	-	-	-	-
Stage 2	-	-	-	-
Critical Hdwy	4.43	-	4.12	-
Critical Hdwy Stg 1	-	-	-	-
Critical Hdwy Stg 2	-	-	-	-
Follow-up Hdwy	2.497	-	2.218	-
Pot Cap-1 Maneuver	981	-	766	-
Stage 1	-	-	-	-
Stage 2	-	-	-	-
Platoon blocked, %	-	-	-	-
Mov Cap-1 Maneuver	980	-	766	-
Mov Cap-2 Maneuver	-	-	-	-
Stage 1	-	-	-	-
Stage 2	-	-	-	-

Approach	EB	WB	NB	SB
HCM Control Delay, s	0.1	0	31.9	20.5
HCM LOS			D	C

Minor Lane/Major Mvmt	NBLn1	EBL	EBT	EBR	WBL	WBT	WBR	SBLn1	SBLn2
Capacity (veh/h)	145	980	-	-	766	-	-	128	545
HCM Lane V/C Ratio	0.076	0.006	-	-	0.001	-	-	0.172	0.09
HCM Control Delay (s)	31.9	8.7	-	-	9.7	-	-	38.9	12.3
HCM Lane LOS	D	A	-	-	A	-	-	E	B
HCM 95th %tile Q(veh)	0.2	0	-	-	0	-	-	0.6	0.3

HCM 2010 TWSC
3: Old Montreal Rd & Famille-Laporte Ave

10/22/2024

Intersection						
Int Delay, s/veh	1.6					
Movement	EBL	EBT	WBT	WBR	SBL	SBR
Lane Configurations	↔	↔	↔		↔	↔
Traffic Vol, veh/h	116	805	356	8	10	74
Future Vol, veh/h	116	805	356	8	10	74
Conflicting Peds, #/hr	0	0	0	0	0	0
Sign Control	Free	Free	Free	Free	Stop	Stop
RT Channelized	-	None	-	None	-	None
Storage Length	155	-	-	-	0	-
Veh in Median Storage, #	-	0	0	-	0	-
Grade, %	-	0	0	-	0	-
Peak Hour Factor	100	100	100	100	100	100
Heavy Vehicles, %	4	2	2	2	2	3
Mvmt Flow	116	805	356	8	10	74

Major/Minor	Major1	Major2	Minor2
Conflicting Flow All	364	0	1397
Stage 1	-	-	360
Stage 2	-	-	1037
Critical Hdwy	4.14	-	6.42
Critical Hdwy Stg 1	-	-	5.42
Critical Hdwy Stg 2	-	-	5.42
Follow-up Hdwy	2.236	-	3.518
Pot Cap-1 Maneuver	1184	-	155
Stage 1	-	-	706
Stage 2	-	-	342
Platoon blocked, %	-	-	-
Mov Cap-1 Maneuver	1184	-	140
Mov Cap-2 Maneuver	-	-	140
Stage 1	-	-	637
Stage 2	-	-	342

Approach	EB	WB	SB
HCM Control Delay, s	1.1	0	14.4
HCM LOS			B

Minor Lane/Major Mvmt	EBL	EBT	WBT	WBR	SBLn1
Capacity (veh/h)	1184	-	-	-	467
HCM Lane V/C Ratio	0.098	-	-	-	0.18
HCM Control Delay (s)	8.4	-	-	-	14.4
HCM Lane LOS	A	-	-	-	B
HCM 95th %tile Q(veh)	0.3	-	-	-	0.6

HCM 2010 TWSC
4: No.1/Cardinal Creek Dr & Old Montreal Rd

10/22/2024

Intersection												
Int Delay, s/veh	3											
Movement	EBL	EBT	EBR	WBL	WBT	WBR	NBL	NBT	NBR	SBL	SBT	SBR
Lane Configurations	↕ ↕ ↕ ↕ ↕ ↕ ↕ ↕ ↕ ↕ ↕ ↕ ↕											
Traffic Vol, veh/h	10	523	192	5	127	1	131	0	3	2	0	6
Future Vol, veh/h	10	523	192	5	127	1	131	0	3	2	0	6
Conflicting Peds, #/hr	0	0	0	0	0	0	0	0	0	0	0	0
Sign Control	Free	Free	Free	Free	Free	Free	Stop	Stop	Stop	Stop	Stop	Stop
RT Channelized	-	-	None	-	-	None	-	-	None	-	-	None
Storage Length	50	-	70	37.5	-	-	-	-	-	-	-	-
Veh in Median Storage, #	-	0	-	-	0	-	-	0	-	-	0	-
Grade, %	-	0	-	-	0	-	-	0	-	-	0	-
Peak Hour Factor	100	100	100	100	100	100	100	100	100	100	100	100
Heavy Vehicles, %	10	2	2	2	2	2	2	2	50	2	2	17
Mvmt Flow	10	523	192	5	127	1	131	0	3	2	0	6

Major/Minor	Major1	Major2	Minor1	Minor2
Conflicting Flow All	128	0	0	715
Stage 1	-	-	-	-
Stage 2	-	-	-	-
Critical Hdwy	4.2	-	-	4.12
Critical Hdwy Stg 1	-	-	-	-
Critical Hdwy Stg 2	-	-	-	-
Follow-up Hdwy	2.29	-	-	2.218
Pot Cap-1 Maneuver	1410	-	-	885
Stage 1	-	-	-	-
Stage 2	-	-	-	-
Platoon blocked, %	-	-	-	-
Mov Cap-1 Maneuver	1410	-	-	885
Mov Cap-2 Maneuver	-	-	-	-
Stage 1	-	-	-	-
Stage 2	-	-	-	-

Approach	EB	WB	NB	SB
HCM Control Delay, s	0.1	0.3	20.8	11.6
HCM LOS			C	B

Minor Lane/Major Mvmt	NBLn1	EBL	EBT	EBR	WBL	WBT	WBR	SBLn1
Capacity (veh/h)	360	1410	-	-	885	-	-	550
HCM Lane V/C Ratio	0.372	0.007	-	-	0.006	-	-	0.015
HCM Control Delay (s)	20.8	7.6	-	-	9.1	-	-	11.6
HCM Lane LOS	C	A	-	-	A	-	-	B
HCM 95th %tile Q(veh)	1.7	0	-	-	0	-	-	0

HCM 2010 TWSC
5: Cox Country Rd/Ted Kelly Ln & Old Montreal Rd

10/22/2024

Intersection												
Int Delay, s/veh	2.2											
Movement	EBL	EBT	EBR	WBL	WBT	WBR	NBL	NBT	NBR	SBL	SBT	SBR
Lane Configurations	↕ ↕ ↕ ↕ ↕ ↕ ↕ ↕ ↕ ↕ ↕ ↕ ↕											
Traffic Vol, veh/h	12	401	115	30	94	1	34	6	44	0	2	5
Future Vol, veh/h	12	401	115	30	94	1	34	6	44	0	2	5
Conflicting Peds, #/hr	0	0	0	0	0	0	0	0	2	0	0	0
Sign Control	Free	Free	Free	Free	Free	Free	Stop	Stop	Stop	Stop	Stop	Stop
RT Channelized	-	-	None	-	-	None	-	-	None	-	-	None
Storage Length	-	-	-	-	-	-	-	-	-	-	-	-
Veh in Median Storage, #	-	0	-	-	0	-	-	0	-	-	0	-
Grade, %	-	0	-	-	0	-	-	0	-	-	0	-
Peak Hour Factor	100	100	100	100	100	100	100	100	100	100	100	100
Heavy Vehicles, %	2	2	3	2	2	2	2	17	3	2	2	2
Mvmt Flow	12	401	115	30	94	1	34	6	44	0	2	5

Major/Minor	Major1	Major2	Minor1	Minor2
Conflicting Flow All	95	0	0	516
Stage 1	-	-	-	-
Stage 2	-	-	-	-
Critical Hdwy	4.12	-	-	4.12
Critical Hdwy Stg 1	-	-	-	-
Critical Hdwy Stg 2	-	-	-	-
Follow-up Hdwy	2.218	-	-	2.218
Pot Cap-1 Maneuver	1499	-	-	1050
Stage 1	-	-	-	-
Stage 2	-	-	-	-
Platoon blocked, %	-	-	-	-
Mov Cap-1 Maneuver	1499	-	-	1050
Mov Cap-2 Maneuver	-	-	-	-
Stage 1	-	-	-	-
Stage 2	-	-	-	-

Approach	EB	WB	NB	SB
HCM Control Delay, s	0.2	2	14.5	10.7
HCM LOS			B	B

Minor Lane/Major Mvmt	NBLn1	EBL	EBT	EBR	WBL	WBT	WBR	SBLn1
Capacity (veh/h)	462	1499	-	-	1050	-	-	642
HCM Lane V/C Ratio	0.182	0.008	-	-	0.029	-	-	0.011
HCM Control Delay (s)	14.5	7.4	0	-	8.5	0	-	10.7
HCM Lane LOS	B	A	A	-	A	A	-	B
HCM 95th %tile Q(veh)	0.7	0	-	-	0.1	-	-	0

Intersection						
Int Delay, s/veh	3.2					
Movement	WBL	WBR	NBT	NBR	SBL	SBT
Lane Configurations	↔		↔			↔
Traffic Vol, veh/h	21	24	78	29	72	83
Future Vol, veh/h	21	24	78	29	72	83
Conflicting Peds, #/hr	0	0	0	0	0	0
Sign Control	Stop	Stop	Free	Free	Free	Free
RT Channelized	-	None	-	None	-	None
Storage Length	0	-	-	-	-	-
Veh in Median Storage, #	0	-	0	-	-	0
Grade, %	0	-	0	-	-	0
Peak Hour Factor	100	100	100	100	100	100
Heavy Vehicles, %	5	2	3	7	3	3
Mvmt Flow	21	24	78	29	72	83

Major/Minor	Minor1	Major1	Major2
Conflicting Flow All	320	93	0
Stage 1	93	-	-
Stage 2	227	-	-
Critical Hdwy	6.45	6.22	-
Critical Hdwy Stg 1	5.45	-	-
Critical Hdwy Stg 2	5.45	-	-
Follow-up Hdwy	3.545	3.318	-
Pot Cap-1 Maneuver	667	964	-
Stage 1	923	-	-
Stage 2	804	-	-
Platoon blocked, %	-	-	-
Mov Cap-1 Maneuver	633	964	-
Mov Cap-2 Maneuver	633	-	-
Stage 1	923	-	-
Stage 2	763	-	-

Approach	WB	NB	SB
HCM Control Delay, s	9.9	0	3.5
HCM LOS	A		

Minor Lane/Major Mvmt	NBT	NBRWBLn1	SBL	SBT
Capacity (veh/h)	-	-	775	1478
HCM Lane V/C Ratio	-	-	0.058	0.049
HCM Control Delay (s)	-	-	9.9	7.6
HCM Lane LOS	-	-	A	A
HCM 95th %tile Q(veh)	-	-	0.2	0.2

Intersection						
Int Delay, s/veh	1.3					
Movement	EBL	EBR	NBL	NBT	SBT	SBR
Lane Configurations	↔			↔	↔	
Traffic Vol, veh/h	5	15	23	79	140	7
Future Vol, veh/h	5	15	23	79	140	7
Conflicting Peds, #/hr	0	0	0	0	0	0
Sign Control	Stop	Stop	Free	Free	Free	Free
RT Channelized	-	None	-	None	-	None
Storage Length	0	-	-	-	-	-
Veh in Median Storage, #	0	-	-	0	0	-
Grade, %	0	-	-	0	0	-
Peak Hour Factor	100	100	100	100	100	100
Heavy Vehicles, %	2	2	2	2	2	2
Mvmt Flow	5	15	23	79	140	7

Major/Minor	Minor2	Major1	Major2
Conflicting Flow All	269	144	147
Stage 1	144	-	-
Stage 2	125	-	-
Critical Hdwy	6.42	6.22	4.12
Critical Hdwy Stg 1	5.42	-	-
Critical Hdwy Stg 2	5.42	-	-
Follow-up Hdwy	3.518	3.318	2.218
Pot Cap-1 Maneuver	720	903	1435
Stage 1	883	-	-
Stage 2	901	-	-
Platoon blocked, %	-	-	-
Mov Cap-1 Maneuver	708	903	1435
Mov Cap-2 Maneuver	708	-	-
Stage 1	868	-	-
Stage 2	901	-	-

Approach	EB	NB	SB
HCM Control Delay, s	9.4	1.7	0
HCM LOS	A		

Minor Lane/Major Mvmt	NBL	NBT EBLn1	SBT	SBR
Capacity (veh/h)	1435	-	845	-
HCM Lane V/C Ratio	0.016	-	0.024	-
HCM Control Delay (s)	7.5	0	9.4	-
HCM Lane LOS	A	A	A	-
HCM 95th %tile Q(veh)	0	-	0.1	-

Appendix L

Synchro Intersection Worksheets – 2032 Future Total Conditions

MOVEMENT SUMMARY

Site: 101 [Trim-Old Montreal AM FT2032 (Site Folder: General)]

Output produced by SIDRA INTERSECTION Version: 9.1.3.210

Tamarak CCV South
Site Category: (None)
Roundabout

Vehicle Movement Performance													
Mov ID	Turn Class	Demand Flows [Total HV]	Arrival Flows [Total HV]	Deg. Satn	Aver. Delay	Level of Service	95% Back Of Queue [Veh.]	Prop. Que	Eff. Stop Rate	Aver. No. of Cycles	Aver. Speed		
		veh/h %	veh/h %	v/c	sec		[Veh.] [Dist]				km/h		
South: Trim													
1	L2	All MCs	254 2.0 254 2.0	0.742	11.6	LOS B	6.8 48.1	0.64	0.67	0.72	51.2		
2	T1	All MCs	1469 2.0 1469 2.0	0.742	6.2	LOS A	6.8 48.1	0.65	0.67	0.75	52.4		
3	R2	All MCs	114 2.0 114 2.0	0.742	6.7	LOS A	6.8 48.1	0.67	0.66	0.77	52.3		
Approach			1837 2.0 1837 2.0	0.742	7.0	LOS A	6.8 48.1	0.65	0.67	0.74	52.2		
East: Old Montreal													
4	L2	All MCs	249 2.0 249 2.0	0.508	18.2	LOS B	3.2 23.0	0.90	1.00	1.13	45.6		
5	T1	All MCs	331 2.0 331 2.0	0.434	9.3	LOS A	3.3 23.5	0.95	0.88	1.07	51.3		
6	R2	All MCs	395 2.0 395 2.0	0.420	6.9	LOS A	2.8 20.0	0.85	0.83	0.93	52.3		
Approach			975 2.0 975 2.0	0.508	10.6	LOS B	3.3 23.5	0.90	0.89	1.03	50.1		
North: Trim													
7	L2	All MCs	169 2.0 169 2.0	0.308	12.3	LOS B	1.6 11.1	0.70	0.77	0.70	49.6		
8	T1	All MCs	300 2.0 300 2.0	0.308	6.1	LOS A	1.7 11.9	0.70	0.63	0.70	52.2		
9	R2	All MCs	30 2.0 30 2.0	0.308	6.1	LOS A	1.7 11.9	0.70	0.60	0.70	52.2		
Approach			499 2.0 499 2.0	0.308	8.2	LOS A	1.7 11.9	0.70	0.68	0.70	51.3		
West: St Joseph													
10	L2	All MCs	61 2.0 61 2.0	0.068	11.0	LOS B	0.3 2.1	0.54	0.71	0.54	49.6		
11	T1	All MCs	94 2.0 94 2.0	0.068	4.8	LOS A	0.3 2.3	0.52	0.48	0.52	53.2		
12	R2	All MCs	42 20.0 42 20.0	0.034	4.7	LOS A	0.1 1.1	0.44	0.54	0.44	53.4		
Approach			197 5.8 197 5.8	0.068	6.7	LOS A	0.3 2.3	0.51	0.57	0.51	52.0		
All Vehicles			3508 2.2 3508 2.2	0.742	8.2	LOS A	6.8 48.1	0.72	0.72	0.80	51.5		

Site Level of Service (LOS) Method: Delay (SIDRA). Site LOS Method is specified in the Parameter Settings dialog (Options tab).
 Roundabout LOS Method: SIDRA Roundabout LOS.
 Vehicle movement LOS values are based on average delay per movement.
 Intersection and Approach LOS values are based on average delay for all vehicle movements.
 Roundabout Capacity Model: SIDRA Standard.
 Delay Model: SIDRA Standard (Control Delay: Geometric Delay is included).
 Queue Model: SIDRA queue estimation methods are used for Back of Queue and Queue at Start of Gap.
 Gap-Acceptance Capacity Formula: SIDRA Standard (Akçelik M3D).
 HV (%) values are calculated for All Movement Classes of All Heavy Vehicle Model Designation.
 Arrival Flows used in performance calculations are adjusted to include any Initial Queued Demand and Upstream Capacity Constraint effects.

SIDRA INTERSECTION 9.1 | Copyright © 2000-2023 Akcelik and Associates Pty Ltd | sidrasolutions.com
 Organisation: CGH TRANSPORTATION | Licence: NETWORK / FLOATING | Processed: Tuesday, October 22, 2024 11:09:29 AM
 Project: Not Saved

Lanes, Volumes, Timings

1: Trim Rd & St Joseph Blvd/Old Montreal Rd

10/22/2024



Lane Group	EBL	EBT	EBR	WBL	WBT	WBR	NBL	NBT	NBR	SBL	SBT	SBR
Lane Configurations		↕↕	↕		↕↕	↕		↕↕			↕↕	
Traffic Volume (vph)	61	94	42	249	331	395	254	1469	114	169	300	30
Future Volume (vph)	61	94	42	249	331	395	254	1469	114	169	300	30
Satd. Flow (prot)	0	3050	1375	0	3166	1483	0	3241	0	0	3114	0
Fit Permitted		0.981			0.979			0.993			0.983	
Satd. Flow (perm)	0	3050	1375	0	3166	1483	0	3241	0	0	3114	0
Lane Group Flow (vph)	0	155	42	0	580	395	0	1837	0	0	499	0
Sign Control		Yield			Yield			Yield			Yield	

Intersection Summary	
Control Type:	Roundabout
Intersection Capacity Utilization	105.0%
ICU Level of Service	G
Analysis Period (min)	15

Intersection												
Int Delay, s/veh	0.8											
Movement	EBL	EBT	EBR	WBL	WBT	WBR	NBL	NBT	NBR	SBL	SBT	SBR
Lane Configurations	↔	↔		↔	↔			↔		↔	↔	
Traffic Vol, veh/h	33	247	5	0	835	27	9	7	0	3	0	7
Future Vol, veh/h	33	247	5	0	835	27	9	7	0	3	0	7
Conflicting Peds, #/hr	0	0	1	1	0	0	2	0	0	0	0	2
Sign Control	Free	Free	Free	Free	Free	Free	Stop	Stop	Stop	Stop	Stop	Stop
RT Channelized	-	-	None	-	-	None	-	-	None	-	-	None
Storage Length	55	-	-	70	-	-	-	-	-	30	-	-
Veh in Median Storage, #	-	0	-	-	0	-	-	0	-	-	0	-
Grade, %	-	0	-	-	0	-	-	0	-	-	0	-
Peak Hour Factor	100	100	100	100	100	100	100	100	100	100	100	100
Heavy Vehicles, %	2	10	2	2	3	2	2	2	2	17	2	2
Mvmt Flow	33	247	5	0	835	27	9	7	0	3	0	7

Major/Minor	Major1	Major2	Minor1	Minor2
Conflicting Flow All	862	0	253	0
Stage 1	-	-	-	-
Stage 2	-	-	-	-
Critical Hdwy	4.12	-	4.12	-
Critical Hdwy Stg 1	-	-	-	-
Critical Hdwy Stg 2	-	-	-	-
Follow-up Hdwy	2.218	-	2.218	-
Pot Cap-1 Maneuver	780	-	1312	-
Stage 1	-	-	-	-
Stage 2	-	-	-	-
Platoon blocked, %	-	-	-	-
Mov Cap-1 Maneuver	780	-	1311	-
Mov Cap-2 Maneuver	-	-	-	-
Stage 1	-	-	-	-
Stage 2	-	-	-	-

Approach	EB	WB	NB	SB
HCM Control Delay, s	1.1	0	28.4	19.6
HCM LOS			D	C

Minor Lane/Major Mvmt	NBLn1	EBL	EBT	EBR	WBL	WBT	WBR	SBLn1	SBLn2
Capacity (veh/h)	170	780	-	-	1311	-	-	149	359
HCM Lane V/C Ratio	0.094	0.042	-	-	-	-	-	0.02	0.019
HCM Control Delay (s)	28.4	9.8	-	-	0	-	-	29.7	15.2
HCM Lane LOS	D	A	-	-	A	-	-	D	C
HCM 95th %tile Q(veh)	0.3	0.1	-	-	0	-	-	0.1	0.1

Intersection									
Int Delay, s/veh	2.3								
Movement	EBL	EBT	WBT	WBR	SBL	SBR			
Lane Configurations	↔	↔	↔		↔	↔			
Traffic Vol, veh/h	51	186	753	9	8	104			
Future Vol, veh/h	51	186	753	9	8	104			
Conflicting Peds, #/hr	0	0	0	0	0	0			
Sign Control	Free	Free	Free	Free	Stop	Stop			
RT Channelized	-	None	-	None	-	None			
Storage Length	155	-	-	-	0	-			
Veh in Median Storage, #	-	0	0	-	0	-			
Grade, %	-	0	0	-	0	-			
Peak Hour Factor	100	100	100	100	100	100			
Heavy Vehicles, %	10	13	2	2	2	8			
Mvmt Flow	51	186	753	9	8	104			

Major/Minor	Major1	Major2	Minor2
Conflicting Flow All	762	0	1046
Stage 1	-	-	758
Stage 2	-	-	288
Critical Hdwy	4.2	-	6.42
Critical Hdwy Stg 1	-	-	5.42
Critical Hdwy Stg 2	-	-	5.42
Follow-up Hdwy	2.29	-	3.518
Pot Cap-1 Maneuver	815	-	253
Stage 1	-	-	463
Stage 2	-	-	761
Platoon blocked, %	-	-	-
Mov Cap-1 Maneuver	815	-	237
Mov Cap-2 Maneuver	-	-	237
Stage 1	-	-	434
Stage 2	-	-	761

Approach	EB	WB	SB
HCM Control Delay, s	2.1	0	18.4
HCM LOS			C

Minor Lane/Major Mvmt	EBL	EBT	WBT	WBR	SBLn1
Capacity (veh/h)	815	-	-	-	379
HCM Lane V/C Ratio	0.063	-	-	-	0.296
HCM Control Delay (s)	9.7	-	-	-	18.4
HCM Lane LOS	A	-	-	-	C
HCM 95th %tile Q(veh)	0.2	-	-	-	1.2

HCM 2010 TWSC
4: No.1/Cardinal Creek Dr & Old Montreal Rd

10/22/2024

Intersection												
Int Delay, s/veh	4.6											
Movement	EBL	EBT	EBR	WBL	WBT	WBR	NBL	NBT	NBR	SBL	SBT	SBR
Lane Configurations	↔	↑	↔	↔	↔			↔		↔	↔	
Traffic Vol, veh/h	11	75	80	2	419	8	187	0	4	0	0	4
Future Vol, veh/h	11	75	80	2	419	8	187	0	4	0	0	4
Conflicting Peds, #/hr	0	0	0	0	0	0	0	0	0	0	0	0
Sign Control	Free	Free	Free	Free	Free	Free	Stop	Stop	Stop	Stop	Stop	Stop
RT Channelized	-	-	None	-	-	None	-	-	None	-	-	None
Storage Length	50	-	70	37.5	-	-	-	-	-	-	-	-
Veh in Median Storage, #	-	0	-	-	0	-	-	0	-	-	0	-
Grade, %	-	0	-	-	0	-	-	0	-	-	0	-
Peak Hour Factor	100	100	100	100	100	100	100	100	100	100	100	100
Heavy Vehicles, %	27	2	2	2	2	25	2	2	2	2	2	75
Mvmt Flow	11	75	80	2	419	8	187	0	4	0	0	4

Major/Minor	Major1	Major2	Minor1	Minor2
Conflicting Flow All	427	0	0	155
Stage 1	-	-	-	-
Stage 2	-	-	-	-
Critical Hdwy	4.37	-	-	4.12
Critical Hdwy Stg 1	-	-	-	-
Critical Hdwy Stg 2	-	-	-	-
Follow-up Hdwy	2.443	-	-	2.218
Pot Cap-1 Maneuver	1011	-	-	1425
Stage 1	-	-	-	-
Stage 2	-	-	-	-
Platoon blocked, %	-	-	-	-
Mov Cap-1 Maneuver	1011	-	-	1425
Mov Cap-2 Maneuver	-	-	-	-
Stage 1	-	-	-	-
Stage 2	-	-	-	-

Approach	EB	WB	NB	SB
HCM Control Delay, s	0.6	0	18.3	12.2
HCM LOS			C	B

Minor Lane/Major Mvmt	NBLn1	EBL	EBT	EBR	WBL	WBT	WBR	SBLn1
Capacity (veh/h)	459	1011	-	-	1425	-	-	501
HCM Lane V/C Ratio	0.416	0.011	-	-	0.001	-	-	0.008
HCM Control Delay (s)	18.3	8.6	-	-	7.5	-	-	12.2
HCM Lane LOS	C	A	-	-	A	-	-	B
HCM 95th %tile Q(veh)	2	0	-	-	0	-	-	0

HCM 2010 TWSC
5: Cox Country Rd/Ted Kelly Ln & Old Montreal Rd

10/22/2024

Intersection												
Int Delay, s/veh	4.6											
Movement	EBL	EBT	EBR	WBL	WBT	WBR	NBL	NBT	NBR	SBL	SBT	SBR
Lane Configurations		↔			↔			↔		↔	↔	
Traffic Vol, veh/h	3	51	25	34	287	2	134	1	22	1	2	8
Future Vol, veh/h	3	51	25	34	287	2	134	1	22	1	2	8
Conflicting Peds, #/hr	0	0	0	0	0	0	0	0	0	0	0	0
Sign Control	Free	Free	Free	Free	Free	Free	Stop	Stop	Stop	Stop	Stop	Stop
RT Channelized	-	-	None	-	-	None	-	-	None	-	-	None
Storage Length	-	-	-	-	-	-	-	-	-	-	-	-
Veh in Median Storage, #	-	0	-	-	0	-	-	0	-	-	0	-
Grade, %	-	0	-	-	0	-	-	0	-	-	0	-
Peak Hour Factor	100	100	100	100	100	100	100	100	100	100	100	100
Heavy Vehicles, %	2	3	2	3	3	2	2	2	7	2	2	2
Mvmt Flow	3	51	25	34	287	2	134	1	22	1	2	8

Major/Minor	Major1	Major2	Minor1	Minor2
Conflicting Flow All	289	0	0	76
Stage 1	-	-	-	-
Stage 2	-	-	-	-
Critical Hdwy	4.12	-	-	4.13
Critical Hdwy Stg 1	-	-	-	-
Critical Hdwy Stg 2	-	-	-	-
Follow-up Hdwy	2.218	-	-	2.227
Pot Cap-1 Maneuver	1273	-	-	1517
Stage 1	-	-	-	-
Stage 2	-	-	-	-
Platoon blocked, %	-	-	-	-
Mov Cap-1 Maneuver	1273	-	-	1517
Mov Cap-2 Maneuver	-	-	-	-
Stage 1	-	-	-	-
Stage 2	-	-	-	-

Approach	EB	WB	NB	SB
HCM Control Delay, s	0.3	0.8	14.1	10.5
HCM LOS			B	B

Minor Lane/Major Mvmt	NBLn1	EBL	EBT	EBR	WBL	WBT	WBR	SBLn1
Capacity (veh/h)	553	1273	-	-	1517	-	-	661
HCM Lane V/C Ratio	0.284	0.002	-	-	0.022	-	-	0.017
HCM Control Delay (s)	14.1	7.8	0	-	7.4	0	-	10.5
HCM Lane LOS	B	A	A	-	A	A	-	B
HCM 95th %tile Q(veh)	1.2	0	-	-	0.1	-	-	0.1

Intersection						
Int Delay, s/veh	4.5					
Movement	WBL	WBR	NBT	NBR	SBL	SBT
Lane Configurations	↔		↔			↔
Traffic Vol, veh/h	33	94	65	8	9	71
Future Vol, veh/h	33	94	65	8	9	71
Conflicting Peds, #/hr	0	0	0	0	1	0
Sign Control	Stop	Stop	Free	Free	Free	Free
RT Channelized	-	None	-	None	-	None
Storage Length	0	-	-	-	-	-
Veh in Median Storage, #	0	-	0	-	-	0
Grade, %	0	-	0	-	-	0
Peak Hour Factor	100	100	100	100	100	100
Heavy Vehicles, %	6	5	3	2	2	11
Mvmt Flow	33	94	65	8	9	71

Major/Minor	Minor1	Major1	Major2
Conflicting Flow All	159	70	0 0 74 0
Stage 1	70	-	- - - -
Stage 2	89	-	- - - -
Critical Hdwy	6.46	6.25	- - 4.12 -
Critical Hdwy Stg 1	5.46	-	- - - -
Critical Hdwy Stg 2	5.46	-	- - - -
Follow-up Hdwy	3,554	3,345	- - 2,218 -
Pot Cap-1 Maneuver	823	984	- - 1526 -
Stage 1	943	-	- - - -
Stage 2	924	-	- - - -
Platoon blocked, %	-	-	- - - -
Mov Cap-1 Maneuver	817	983	- - 1525 -
Mov Cap-2 Maneuver	817	-	- - - -
Stage 1	942	-	- - - -
Stage 2	918	-	- - - -

Approach	WB	NB	SB
HCM Control Delay, s	9.5	0	0.8
HCM LOS	A		

Minor Lane/Major Mvmt	NBT	NBRWBLn1	SBL	SBT
Capacity (veh/h)	-	- 934	1525	-
HCM Lane V/C Ratio	-	- 0.136	0.006	-
HCM Control Delay (s)	-	- 9.5	7.4	0
HCM Lane LOS	-	- A	A	A
HCM 95th %tile Q(veh)	-	- 0.5	0	-

Intersection						
Int Delay, s/veh	1.3					
Movement	EBL	EBR	NBL	NBT	SBT	SBR
Lane Configurations	↔			↔	↔	
Traffic Vol, veh/h	7	22	9	150	58	3
Future Vol, veh/h	7	22	9	150	58	3
Conflicting Peds, #/hr	0	0	0	0	0	0
Sign Control	Stop	Stop	Free	Free	Free	Free
RT Channelized	-	None	-	None	-	None
Storage Length	0	-	-	-	-	-
Veh in Median Storage, #	0	-	-	0	0	-
Grade, %	0	-	-	0	0	-
Peak Hour Factor	100	100	100	100	100	100
Heavy Vehicles, %	2	2	2	2	2	2
Mvmt Flow	7	22	9	150	58	3

Major/Minor	Minor2	Major1	Major2
Conflicting Flow All	228	60	61 0 - 0
Stage 1	60	-	- - - -
Stage 2	168	-	- - - -
Critical Hdwy	6.42	6.22	4.12 - - -
Critical Hdwy Stg 1	5.42	-	- - - -
Critical Hdwy Stg 2	5.42	-	- - - -
Follow-up Hdwy	3,518	3,318	2,218 - - -
Pot Cap-1 Maneuver	760	1005	1542 - - -
Stage 1	963	-	- - - -
Stage 2	862	-	- - - -
Platoon blocked, %	-	-	- - - -
Mov Cap-1 Maneuver	755	1005	1542 - - -
Mov Cap-2 Maneuver	755	-	- - - -
Stage 1	957	-	- - - -
Stage 2	862	-	- - - -

Approach	EB	NB	SB
HCM Control Delay, s	9	0.4	0
HCM LOS	A		

Minor Lane/Major Mvmt	NBL	NBT EBLn1	SBT	SBR
Capacity (veh/h)	1542	- 931	-	-
HCM Lane V/C Ratio	0.006	- 0.031	-	-
HCM Control Delay (s)	7.3	0	9	-
HCM Lane LOS	A	A	A	-
HCM 95th %tile Q(veh)	0	- 0.1	-	-

MOVEMENT SUMMARY

Site: 101 [Trim-Old Montreal PM FT2032 (Site Folder: General)]

Output produced by SIDRA INTERSECTION Version: 9.1.3.210

Tamarak CCV South
Site Category: (None)
Roundabout

Vehicle Movement Performance													
Mov ID	Turn Class	Mov Class	Demand Flows [Total HV]	Arrival Flows [Total HV]	Deg. Satn	Aver. Delay	Level of Service	95% Back Of Queue [Veh.]	Prop. Que. Dist [m]	Prop. Que.	Eff. Stop Rate	Aver. No. of Cycles	Aver. Speed
			veh/h %	veh/h %	v/c	sec							km/h
South: Trim													
1	L2	All MCs	123 2.0	123 2.0	0.540	13.5	LOS B	3.6	25.5	0.82	0.86	0.98	50.2
2	T1	All MCs	490 2.0	490 2.0	0.540	8.2	LOS A	3.6	25.5	0.81	0.87	0.98	51.3
3	R2	All MCs	173 2.0	173 2.0	0.540	9.1	LOS A	3.2	23.0	0.80	0.90	0.99	51.3
Approach			786 2.0	786 2.0	0.540	9.2	LOS A	3.6	25.5	0.81	0.87	0.98	51.1
East: Old Montreal													
4	L2	All MCs	178 2.0	178 2.0	0.188	11.1	LOS B	0.9	6.7	0.60	0.73	0.60	49.1
5	T1	All MCs	201 2.0	201 2.0	0.160	4.9	LOS A	0.9	6.2	0.58	0.48	0.58	53.0
6	R2	All MCs	268 2.0	268 2.0	0.200	4.7	LOS A	1.1	7.5	0.53	0.56	0.53	53.5
Approach			647 2.0	647 2.0	0.200	6.5	LOS A	1.1	7.5	0.57	0.58	0.57	52.0
North: Trim													
7	L2	All MCs	641 2.0	641 2.0	1.252	130.5	LOS F	89.2	635.1	1.00	3.65	7.36	19.7
8	T1	All MCs	1914 2.0	1914 2.0	1.252	123.8	LOS F	102.8	731.9	1.00	3.82	7.57	20.1
9	R2	All MCs	61 2.0	61 2.0	1.252	123.5	LOS F	102.8	731.9	1.00	3.89	7.65	20.1
Approach			2616 2.0	2616 2.0	1.252	125.4	LOS F	102.8	731.9	1.00	3.78	7.52	20.0
West: St Joseph													
10	L2	All MCs	54 2.0	54 2.0	0.874	40.5	LOS D	7.7	54.7	1.00	1.26	1.88	37.4
11	T1	All MCs	650 2.0	650 2.0	0.874	35.0	LOS D	11.3	80.5	1.00	1.32	1.97	38.1
12	R2	All MCs	303 2.0	303 2.0	0.499	11.6	LOS B	4.2	29.6	1.00	0.93	1.16	49.5
Approach			1007 2.0	1007 2.0	0.874	28.3	LOS C	11.3	80.5	1.00	1.20	1.72	40.8
All Vehicles			5056 2.0	5056 2.0	1.252	72.8	LOS F	102.8	731.9	0.92	2.40	4.46	27.5

Site Level of Service (LOS) Method: Delay (SIDRA). Site LOS Method is specified in the Parameter Settings dialog (Options tab).
 Roundabout LOS Method: SIDRA Roundabout LOS.
 Vehicle movement LOS values are based on average delay per movement.
 Intersection and Approach LOS values are based on average delay for all vehicle movements.
 Roundabout Capacity Model: SIDRA Standard.
 Delay Model: SIDRA Standard (Control Delay: Geometric Delay is included).
 Queue Model: SIDRA queue estimation methods are used for Back of Queue and Queue at Start of Gap.
 Gap-Acceptance Capacity Formula: SIDRA Standard (Akçelik M3D).
 HV (%) values are calculated for All Movement Classes of All Heavy Vehicle Model Designation.
 Arrival Flows used in performance calculations are adjusted to include any Initial Queued Demand and Upstream Capacity Constraint effects.

SIDRA INTERSECTION 9.1 | Copyright © 2000-2023 Akcelik and Associates Pty Ltd | sidrasolutions.com
 Organisation: CGH TRANSPORTATION | Licence: NETWORK / FLOATING | Processed: Tuesday, October 22, 2024 11:09:30 AM
 Project: Not Saved

Lanes, Volumes, Timings

1: Trim Rd & St Joseph Blvd/Old Montreal Rd

10/22/2024



Lane Group	EBL	EBT	EBR	WBL	WBT	WBR	NBL	NBT	NBR	SBL	SBT	SBR
Lane Configurations		↕↕	↕		↕↕	↕		↕↕			↕↕	
Traffic Volume (vph)	54	650	303	178	201	268	123	490	173	641	1914	61
Future Volume (vph)	54	650	303	178	201	268	123	490	173	641	1914	61
Satd. Flow (prot)	0	3302	1483	0	3239	1483	0	3161	0	0	3266	0
Fit Permitted		0.996			0.977			0.992			0.988	
Satd. Flow (perm)	0	3302	1483	0	3239	1483	0	3161	0	0	3266	0
Lane Group Flow (vph)	0	704	303	0	379	268	0	786	0	0	2616	0
Sign Control		Yield			Yield			Yield			Yield	

Intersection Summary	
Control Type:	Roundabout
Intersection Capacity Utilization	146.8%
ICU Level of Service	H
Analysis Period (min)	15

Intersection												
Int Delay, s/veh	1.6											
Movement	EBL	EBT	EBR	WBL	WBT	WBR	NBL	NBT	NBR	SBL	SBT	SBR
Lane Configurations	↔		↔		↔		↔		↔		↔	
Traffic Vol, veh/h	6	1204	9	1	422	9	4	6	1	22	2	47
Future Vol, veh/h	6	1204	9	1	422	9	4	6	1	22	2	47
Conflicting Peds, #/hr	1	0	0	0	0	1	0	0	2	2	0	0
Sign Control	Free	Free	Free	Free	Free	Free	Stop	Stop	Stop	Stop	Stop	Stop
RT Channelized	-	-	None	-	-	None	-	-	None	-	-	None
Storage Length	55	-	-	70	-	-	-	-	-	30	-	-
Veh in Median Storage, #	-	0	-	-	0	-	-	0	-	-	0	-
Grade, %	-	0	-	-	0	-	-	0	-	-	0	-
Peak Hour Factor	100	100	100	100	100	100	100	100	100	100	100	100
Heavy Vehicles, %	33	2	2	2	6	2	2	2	2	2	2	10
Mvmt Flow	6	1204	9	1	422	9	4	6	1	22	2	47

Major/Minor	Major1	Major2	Minor1	Minor2
Conflicting Flow All	432	0	0	1213
Stage 1	-	-	-	-
Stage 2	-	-	-	-
Critical Hdwy	4.43	-	-	4.12
Critical Hdwy Stg 1	-	-	-	-
Critical Hdwy Stg 2	-	-	-	-
Follow-up Hdwy	2.497	-	-	2.218
Pot Cap-1 Maneuver	981	-	-	575
Stage 1	-	-	-	-
Stage 2	-	-	-	-
Platoon blocked, %	-	-	-	-
Mov Cap-1 Maneuver	980	-	-	575
Mov Cap-2 Maneuver	-	-	-	-
Stage 1	-	-	-	-
Stage 2	-	-	-	-

Approach	EB	WB	NB	SB
HCM Control Delay, s	0	0	51.7	31.9
HCM LOS			F	D

Minor Lane/Major Mvmt	NBLn1	EBL	EBT	EBR	WBL	WBT	WBR	SBLn1	SBLn2
Capacity (veh/h)	88	980	-	-	575	-	-	73	502
HCM Lane V/C Ratio	0.125	0.006	-	-	0.002	-	-	0.301	0.098
HCM Control Delay (s)	51.7	8.7	-	-	11.3	-	-	74.3	12.9
HCM Lane LOS	F	A	-	-	B	-	-	F	B
HCM 95th %tile Q(veh)	0.4	0	-	-	0	-	-	1.1	0.3

Intersection										
Int Delay, s/veh	1.4									
Movement	EBL	EBT	WBT	WBR	SBL	SBR				
Lane Configurations	↔		↔		↔					
Traffic Vol, veh/h	116	1135	356	8	10	74				
Future Vol, veh/h	116	1135	356	8	10	74				
Conflicting Peds, #/hr	0	0	0	0	0	0				
Sign Control	Free	Free	Free	Free	Stop	Stop				
RT Channelized	-	None	-	None	-	None				
Storage Length	155	-	-	-	0	-				
Veh in Median Storage, #	-	0	0	-	0	-				
Grade, %	-	0	0	-	0	-				
Peak Hour Factor	100	100	100	100	100	100				
Heavy Vehicles, %	4	2	2	2	2	3				
Mvmt Flow	116	1135	356	8	10	74				

Major/Minor	Major1	Major2	Minor2
Conflicting Flow All	364	0	0
Stage 1	-	-	-
Stage 2	-	-	-
Critical Hdwy	4.14	-	-
Critical Hdwy Stg 1	-	-	-
Critical Hdwy Stg 2	-	-	-
Follow-up Hdwy	2.236	-	-
Pot Cap-1 Maneuver	1184	-	-
Stage 1	-	-	-
Stage 2	-	-	-
Platoon blocked, %	-	-	-
Mov Cap-1 Maneuver	1184	-	-
Mov Cap-2 Maneuver	-	-	-
Stage 1	-	-	-
Stage 2	-	-	-

Approach	EB	WB	SB
HCM Control Delay, s	0.8	0	17.3
HCM LOS			C

Minor Lane/Major Mvmt	EBL	EBT	WBT	WBR	SBLn1
Capacity (veh/h)	1184	-	-	-	376
HCM Lane V/C Ratio	0.098	-	-	-	0.223
HCM Control Delay (s)	8.4	-	-	-	17.3
HCM Lane LOS	A	-	-	-	C
HCM 95th %tile Q(veh)	0.3	-	-	-	0.8

HCM 2010 TWSC
4: No.1/Cardinal Creek Dr & Old Montreal Rd

10/22/2024

Intersection												
Int Delay, s/veh	3.1											
Movement	EBL	EBT	EBR	WBL	WBT	WBR	NBL	NBT	NBR	SBL	SBT	SBR
Lane Configurations	↔	↑	↔	↔	↔			↔		↔	↔	
Traffic Vol, veh/h	10	563	192	5	127	1	131	0	3	2	0	6
Future Vol, veh/h	10	563	192	5	127	1	131	0	3	2	0	6
Conflicting Peds, #/hr	0	0	0	0	0	0	0	0	0	0	0	0
Sign Control	Free	Free	Free	Free	Free	Free	Stop	Stop	Stop	Stop	Stop	Stop
RT Channelized	-	-	None	-	-	None	-	-	None	-	-	None
Storage Length	50	-	70	37.5	-	-	-	-	-	-	-	-
Veh in Median Storage, #	-	0	-	-	0	-	-	0	-	-	0	-
Grade, %	-	0	-	-	0	-	-	0	-	-	0	-
Peak Hour Factor	100	100	100	100	100	100	100	100	100	100	100	100
Heavy Vehicles, %	10	2	2	2	2	2	2	2	2	50	2	17
Mvmt Flow	10	563	192	5	127	1	131	0	3	2	0	6

Major/Minor	Major1	Major2	Minor1	Minor2
Conflicting Flow All	128	0	0	724
Stage 1	-	-	-	583
Stage 2	-	-	-	141
Critical Hdwy	4.2	-	4.12	7.12
Critical Hdwy Stg 1	-	-	-	6.12
Critical Hdwy Stg 2	-	-	-	6.12
Follow-up Hdwy	2.29	-	2.218	3.518
Pot Cap-1 Maneuver	1410	-	855	341
Stage 1	-	-	-	498
Stage 2	-	-	-	862
Platoon blocked, %	-	-	-	-
Mov Cap-1 Maneuver	1410	-	855	335
Mov Cap-2 Maneuver	-	-	-	335
Stage 1	-	-	-	495
Stage 2	-	-	-	851

Approach	EB	WB	NB	SB
HCM Control Delay, s	0.1	0.3	22.5	11.9
HCM LOS			C	B

Minor Lane/Major Mvmt	NBLn1	EBL	EBT	EBR	WBL	WBT	WBR	SBLn1
Capacity (veh/h)	338	1410	-	-	855	-	-	530
HCM Lane V/C Ratio	0.396	0.007	-	-	0.006	-	-	0.015
HCM Control Delay (s)	22.5	7.6	-	-	9.2	-	-	11.9
HCM Lane LOS	C	A	-	-	A	-	-	B
HCM 95th %tile Q(veh)	1.8	0	-	-	0	-	-	0

HCM 2010 TWSC
5: Cox Country Rd/Ted Kelly Ln & Old Montreal Rd

10/22/2024

Intersection												
Int Delay, s/veh	2.2											
Movement	EBL	EBT	EBR	WBL	WBT	WBR	NBL	NBT	NBR	SBL	SBT	SBR
Lane Configurations		↔			↔			↔		↔	↔	
Traffic Vol, veh/h	12	441	115	30	94	1	34	6	44	0	2	5
Future Vol, veh/h	12	441	115	30	94	1	34	6	44	0	2	5
Conflicting Peds, #/hr	0	0	0	0	0	0	0	0	2	0	0	0
Sign Control	Free	Free	Free	Free	Free	Free	Stop	Stop	Stop	Stop	Stop	Stop
RT Channelized	-	-	None	-	-	None	-	-	None	-	-	None
Storage Length	-	-	-	-	-	-	-	-	-	-	-	-
Veh in Median Storage, #	-	0	-	-	0	-	-	0	-	-	0	-
Grade, %	-	0	-	-	0	-	-	0	-	-	0	-
Peak Hour Factor	100	100	100	100	100	100	100	100	100	100	100	100
Heavy Vehicles, %	2	2	3	2	2	2	2	17	3	2	2	2
Mvmt Flow	12	441	115	30	94	1	34	6	44	0	2	5

Major/Minor	Major1	Major2	Minor1	Minor2
Conflicting Flow All	95	0	0	556
Stage 1	-	-	-	523
Stage 2	-	-	-	158
Critical Hdwy	4.12	-	4.12	7.12
Critical Hdwy Stg 1	-	-	-	6.12
Critical Hdwy Stg 2	-	-	-	6.12
Follow-up Hdwy	2.218	-	2.218	3.518
Pot Cap-1 Maneuver	1499	-	1015	364
Stage 1	-	-	-	537
Stage 2	-	-	-	844
Platoon blocked, %	-	-	-	-
Mov Cap-1 Maneuver	1499	-	1015	349
Mov Cap-2 Maneuver	-	-	-	349
Stage 1	-	-	-	531
Stage 2	-	-	-	811

Approach	EB	WB	NB	SB
HCM Control Delay, s	0.2	2.1	15.2	10.8
HCM LOS			C	B

Minor Lane/Major Mvmt	NBLn1	EBL	EBT	EBR	WBL	WBT	WBR	SBLn1
Capacity (veh/h)	436	1499	-	-	1015	-	-	624
HCM Lane V/C Ratio	0.193	0.008	-	-	0.03	-	-	0.011
HCM Control Delay (s)	15.2	7.4	0	-	8.7	0	-	10.8
HCM Lane LOS	C	A	A	-	A	A	-	B
HCM 95th %tile Q(veh)	0.7	0	-	-	0.1	-	-	0

Intersection						
Int Delay, s/veh	3.2					
Movement	WBL	WBR	NBT	NBR	SBL	SBT
Lane Configurations	↔		↔			↔
Traffic Vol, veh/h	21	24	78	29	72	83
Future Vol, veh/h	21	24	78	29	72	83
Conflicting Peds, #/hr	0	0	0	0	0	0
Sign Control	Stop	Stop	Free	Free	Free	Free
RT Channelized	-	None	-	None	-	None
Storage Length	0	-	-	-	-	-
Veh in Median Storage, #	0	-	0	-	-	0
Grade, %	0	-	0	-	-	0
Peak Hour Factor	100	100	100	100	100	100
Heavy Vehicles, %	5	2	3	7	3	3
Mvmt Flow	21	24	78	29	72	83

Major/Minor	Minor1	Major1	Major2
Conflicting Flow All	320	93	0
Stage 1	93	-	-
Stage 2	227	-	-
Critical Hdwy	6.45	6.22	-
Critical Hdwy Stg 1	5.45	-	-
Critical Hdwy Stg 2	5.45	-	-
Follow-up Hdwy	3.545	3.318	-
Pot Cap-1 Maneuver	667	964	-
Stage 1	923	-	-
Stage 2	804	-	-
Platoon blocked, %	-	-	-
Mov Cap-1 Maneuver	633	964	-
Mov Cap-2 Maneuver	633	-	-
Stage 1	923	-	-
Stage 2	763	-	-

Approach	WB	NB	SB
HCM Control Delay, s	9.9	0	3.5
HCM LOS	A		

Minor Lane/Major Mvmt	NBT	NBRWBLn1	SBL	SBT
Capacity (veh/h)	-	-	775	1478
HCM Lane V/C Ratio	-	-	0.058	0.049
HCM Control Delay (s)	-	-	9.9	7.6
HCM Lane LOS	-	-	A	A
HCM 95th %tile Q(veh)	-	-	0.2	0.2

Intersection						
Int Delay, s/veh	1.3					
Movement	EBL	EBR	NBL	NBT	SBT	SBR
Lane Configurations	↔			↔	↔	
Traffic Vol, veh/h	5	15	23	79	140	7
Future Vol, veh/h	5	15	23	79	140	7
Conflicting Peds, #/hr	0	0	0	0	0	0
Sign Control	Stop	Stop	Free	Free	Free	Free
RT Channelized	-	None	-	None	-	None
Storage Length	0	-	-	-	-	-
Veh in Median Storage, #	0	-	-	0	0	-
Grade, %	0	-	-	0	0	-
Peak Hour Factor	100	100	100	100	100	100
Heavy Vehicles, %	2	2	2	2	2	2
Mvmt Flow	5	15	23	79	140	7

Major/Minor	Minor2	Major1	Major2
Conflicting Flow All	269	144	147
Stage 1	144	-	-
Stage 2	125	-	-
Critical Hdwy	6.42	6.22	4.12
Critical Hdwy Stg 1	5.42	-	-
Critical Hdwy Stg 2	5.42	-	-
Follow-up Hdwy	3.518	3.318	2.218
Pot Cap-1 Maneuver	720	903	1435
Stage 1	883	-	-
Stage 2	901	-	-
Platoon blocked, %	-	-	-
Mov Cap-1 Maneuver	708	903	1435
Mov Cap-2 Maneuver	708	-	-
Stage 1	868	-	-
Stage 2	901	-	-

Approach	EB	NB	SB
HCM Control Delay, s	9.4	1.7	0
HCM LOS	A		

Minor Lane/Major Mvmt	NBL	NBT EBLn1	SBT	SBR
Capacity (veh/h)	1435	-	845	-
HCM Lane V/C Ratio	0.016	-	0.024	-
HCM Control Delay (s)	7.5	0	9.4	-
HCM Lane LOS	A	A	A	-
HCM 95th %tile Q(veh)	0	-	0.1	-

Appendix M

TDM Checklist

TDM Measures Checklist:
Residential Developments (multi-family, condominium or subdivision)

Legend	
BASIC	The measure is generally feasible and effective, and in most cases would benefit the development and its users
BETTER	The measure could maximize support for users of sustainable modes, and optimize development performance
★	The measure is one of the most dependably effective tools to encourage the use of sustainable modes

TDM measures: Residential developments		Check if proposed & add descriptions
1. TDM PROGRAM MANAGEMENT		
1.1 Program coordinator		
BASIC ★	1.1.1 Designate an internal coordinator, or contract with an external coordinator	<input type="checkbox"/>
1.2 Travel surveys		
BETTER	1.2.1 Conduct periodic surveys to identify travel-related behaviours, attitudes, challenges and solutions, and to track progress	<input type="checkbox"/>
2. WALKING AND CYCLING		
2.1 Information on walking/cycling routes & destinations		
BASIC	2.1.1 Display local area maps with walking/cycling access routes and key destinations at major entrances (<i>multi-family, condominium</i>)	<input type="checkbox"/>
2.2 Bicycle skills training		
BETTER	2.2.1 Offer on-site cycling courses for residents, or subsidize off-site courses	<input type="checkbox"/>

TDM measures: Residential developments		Check if proposed & add descriptions
3. TRANSIT		
3.1 Transit information		
BASIC	3.1.1 Display relevant transit schedules and route maps at entrances (<i>multi-family, condominium</i>)	<input type="checkbox"/>
BETTER	3.1.2 Provide real-time arrival information display at entrances (<i>multi-family, condominium</i>)	<input type="checkbox"/>
3.2 Transit fare incentives		
BASIC ★	3.2.1 Offer PRESTO cards preloaded with one monthly transit pass on residence purchase/move-in, to encourage residents to use transit	<input type="checkbox"/>
BETTER	3.2.2 Offer at least one year of free monthly transit passes on residence purchase/move-in	<input checked="" type="checkbox"/>
3.3 Enhanced public transit service		
BETTER ★	3.3.1 Contract with OC Transpo to provide early transit services until regular services are warranted by occupancy levels (<i>subdivision</i>)	<input checked="" type="checkbox"/>
3.4 Private transit service		
BETTER	3.4.1 Provide shuttle service for seniors homes or lifestyle communities (e.g. scheduled mall or supermarket runs)	<input type="checkbox"/>
4. CARSHARING & BIKESHARING		
4.1 Bikeshare stations & memberships		
BETTER	4.1.1 Contract with provider to install on-site bikeshare station (<i>multi-family</i>)	<input type="checkbox"/>
BETTER	4.1.2 Provide residents with bikeshare memberships, either free or subsidized (<i>multi-family</i>)	<input type="checkbox"/>
4.2 Carshare vehicles & memberships		
BETTER	4.2.1 Contract with provider to install on-site carshare vehicles and promote their use by residents	<input type="checkbox"/>
BETTER	4.2.2 Provide residents with carshare memberships, either free or subsidized	<input type="checkbox"/>
5. PARKING		
5.1 Priced parking		
BASIC ★	5.1.1 Unbundle parking cost from purchase price (<i>condominium</i>)	<input type="checkbox"/>
BASIC ★	5.1.2 Unbundle parking cost from monthly rent (<i>multi-family</i>)	<input type="checkbox"/>

TDM measures: <i>Residential developments</i>		Check if proposed & add descriptions
6. TDM MARKETING & COMMUNICATIONS		
6.1 Multimodal travel information		
BASIC ★	6.1.1 Provide a multimodal travel option information package to new residents	<input checked="" type="checkbox"/>
6.2 Personalized trip planning		
BETTER ★	6.2.1 Offer personalized trip planning to new residents	<input type="checkbox"/>