

# Petrie's Landing III

**Design Brief - DRAFT**

16 October 2023

# Contents

- 1** Design Principles & Planning Strategy ..... **Page 3**
- 2** Site Circulation ..... **Page 8**
- 3** Open Space & Public Realm Approach ..... **Page 10**
- 4** Streetscape Approach ..... **Page 12**
- 5** Massing - Height, Density & Transition ..... **Page 16**
- 6** Architectural Expression ..... **Page 20**
- 7** Sustainability Measures ..... **Page 23**
- 8** Sun Shadow Studies ..... **Page 25**



# Site Introduction

## 1 | Design Principles & Planning Strategy

The site is located between Jeanne-d'Arc Boulevard to the north and Queensway to the south and is surrounded by suburban neighbourhoods and local businesses. The site is currently vacant and has the opportunity to transform into a lively mixed-use neighbourhood that increases residential density and contributes to the local community.

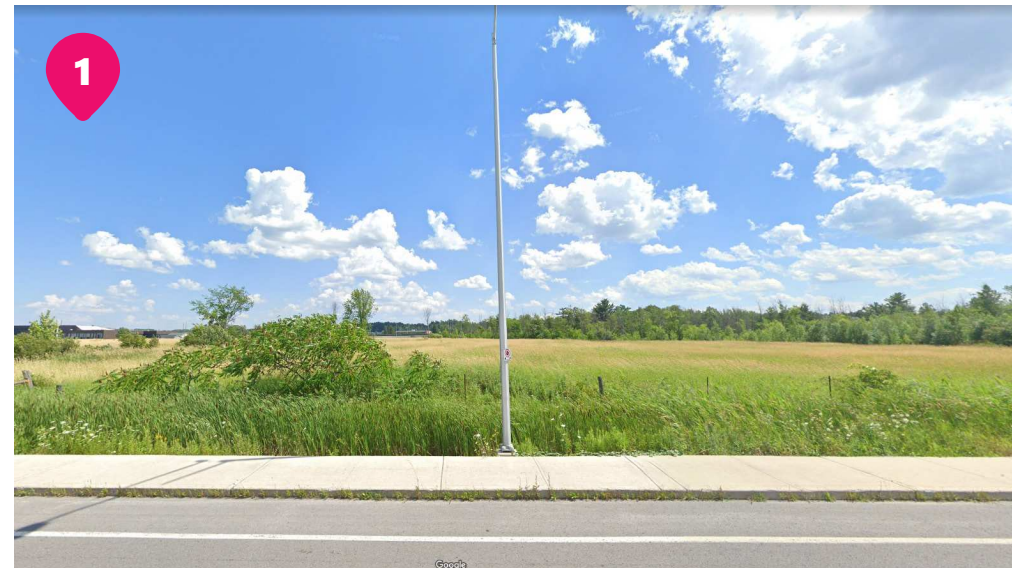

Looking Southeast on Jeanne-d'Arc Blvd



Looking West from Centre des métiers Minto



Looking South to Taylor Creek

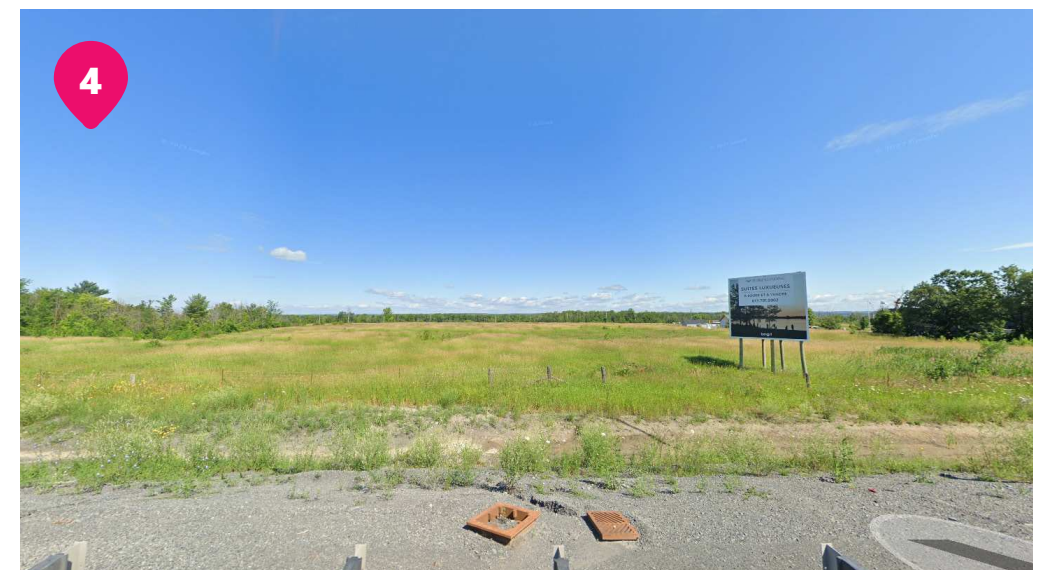

Looking Northwest on Queensway



# Opportunities & Constraints

## LEGEND

5 & 10 Minute Walk (400m & 800m)

Contextual Development | Proposed

600m Transit Area Boundary

Protected Major Transit Area Boundary

Active Transportation Bridge  
(Schedule C - OCSP)

Transit Bus Route



- ① 1009 Trim Road (32, 28 & 24-ST)  
93780633 Quebec Inc.
- ② 3277 St. Joseph Boulevard (9-ST)  
Landric Homes
- ③ 3459 and 3479 St. Joseph Boulevard (6-ST)  
8417709 Canada Inc.
- ④ 1154, 1172, 1176, 1180 and 1208 Old Montreal  
Road (2-4-ST)  
DCR Phoenix Group of Companies



OTTAWA OFFICIAL PLAN  
NEIGHBOURHOOD & GREEN SPACE







**GENERAL DISCLAIMER:** For the purpose of this preliminary study, the property lines shown are approximate. The information has been obtained from the City of Ottawa online property data ma



# Site Analysis

## LEGEND

- Subject Site 
- Floodplain 
- 15m Setback from Top of Slope 
- Potential Location for POPs (Schedule C - OCSP) 
- Multi-purpose Trail 

## OTTAWA ZONING BY-LAW 2008-250

### DR - Development Reserve Zone

- Permitted uses: Agriculture, environmental preserve, group home, one detached dwelling accessory, park, secondary dwelling unit
- Not permitted: new buildings
- Max. HT 11m
- Max. 30% lot coverage

### O1 - Parks and Open Space Zone

- Permitted uses: Environmental preserve, education, park, urban agriculture

## OTTAWA OFFICIAL PLAN

- Policy Area: Suburban
  - Land Use: Neighbourhood and Open Space

## ORLEANS CORRIDOR SECONDARY PLAN (OCSP)

- Land Use: Station Periphery/Core
  - mid-rise with opportunity for some high-rise
- Max. HT 9 & 40-ST

## OTTAWA HIGH RISE GUIDELINES

- Max. 750sm tower floor plate (Residential)
- Max. 2000sm floor plate (Office)
- Min. 23m tower separation (29-ST & below)
- Min. 25m tower separation (30-ST+)
- Min. 1.5m-3m podium to tower stepback, including balconies



**GENERAL DISCLAIMER:** For the purpose of this preliminary study, the property lines shown are approximate. The information has been obtained from the City of Ottawa online property data maps.



# Concept Plan

## 1 | Design Principles & Planning Strategy

Petrie's Landing III has potential to create a mixed-use walkable development that introduces commercial and residential areas, open landscape areas, and create a variety of public spaces that foster a community atmosphere. The edges of the site have the opportunity to create frontages along Jeanne-D'Arc Boulevard and activate the streetscape. Within the site itself new blocks and buildings are organized with higher density on the south by the Queensway and transition to mid-rise buildings along Jeanne-D'Arc Boulevard. The massing strives to maximize frontage and create a hierarchy in the site. The towers are arranged to provide generous separations which ensure views and natural light for both the residents of the towers and to allow sun light and airflow to adequately pass through the towers to the public realm. The network of sidewalks and various open spaces and parks encourage pedestrian movement, which generates more commercial activity for new commercial spaces and frontages which connect and attract pedestrians to the new developments within the site.



- Tower Separation Dimensions
- Tower Separation Dimensions
- Phasing Line



# Context Plan

1 | Design Principles & Planning Strategy

Ottawa River



# Public vs. Private Roads

## 2 | Site Circulation

The site introduces three entrances from Jeanne d'Arc Boulevard. A new public road that loops into the development that the majority of people entering the site will use. Two new private streets will connect the site to the adjacent property to the east in a future scenario. The streets will be designed to enhance the streetscape and contribute to maintaining safety within the development. Parking will be provided below grade and will be publicly accessible.





# Landscape + Public Space

## 3 | Open Space & Public Realm Approach

The landscape and public spaces are made up of a variety of typologies that relate to the planned character and use of their adjacencies. All proposed open spaces should be designed to encourage use throughout all seasons by providing weather protection and flexibility to support seasonal programming and events. The Public Realm should be designed to focus on placemaking and creating active and vital spaces that provide for, and encourage, the activities that will occur daily and seasonally. Flexibility is required to allow for future potential opportunities to support new mobility infrastructure and technology.





# Approach to Open Space





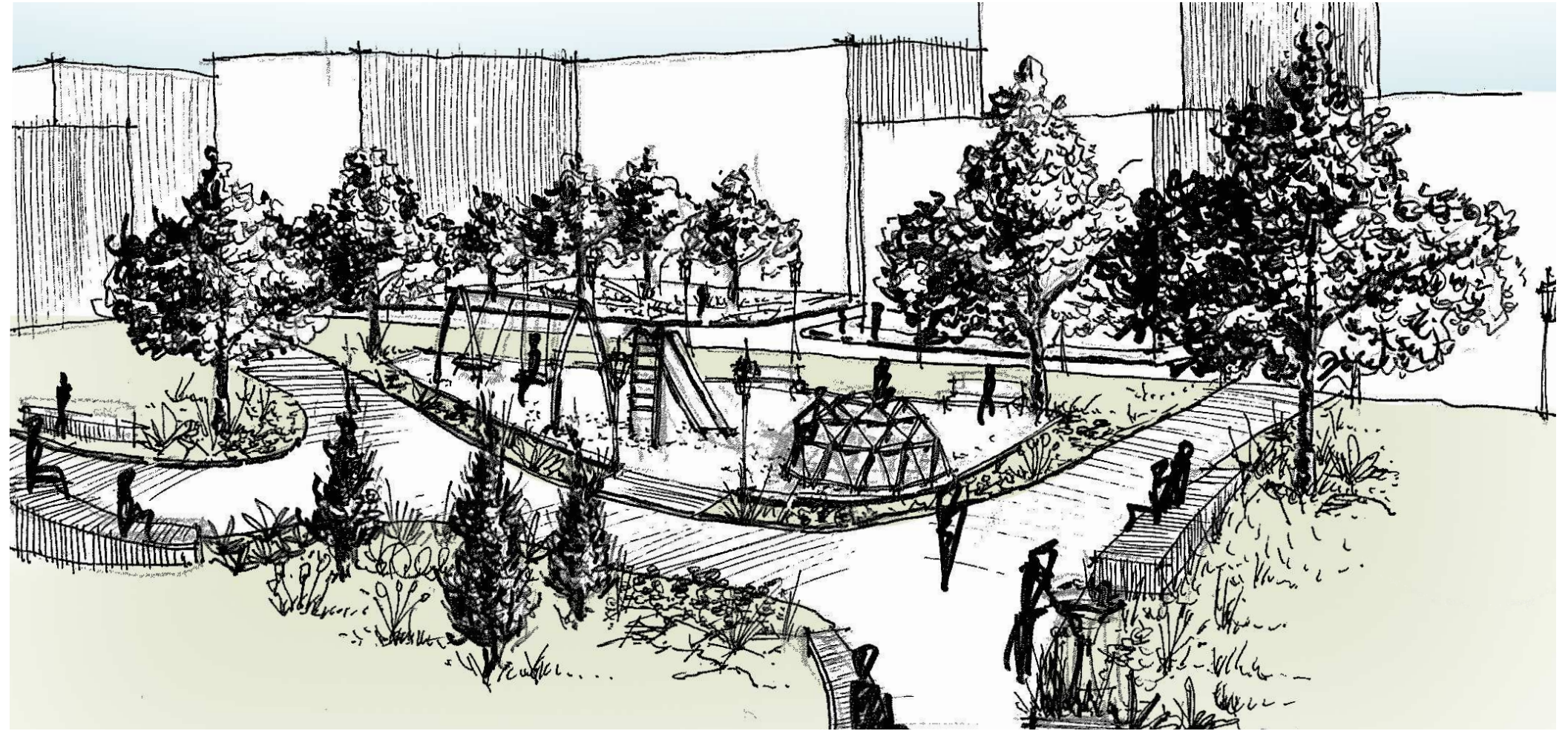



## 3 | Open Space & Public Realm Approach

Open spaces provides important opportunities for recreation and social interaction. Some desired uses may include passive recreation, active recreation, spaces for cultural events, playgrounds and picnic areas. The open spaces should be designed with a focus on accessibility, inclusivity and flexibility. Open spaces should be designed to be well-connected to streets, buildings, and other open spaces. This might involve designing the open space to function as a greenway or linear park that connects different neighborhoods or districts within the development. The open space should also be designed with ecological sustainability in mind. This might involve incorporating features such as rain gardens, bioswales, green roofs to manage stormwater, using native plants to provide habitat for wildlife, or incorporating sustainable design strategies such as permeable paving or energy-efficient lighting.





# Demonstration Plan

-  Tower Separation Dimensions
-  Tower Separation Dimensions
-  Phasing Line
-  Future Connection
-  Public Road
-  Private Road
-  Primary Entrance
-  Secondary Entrance
-  Non-Residential Podium

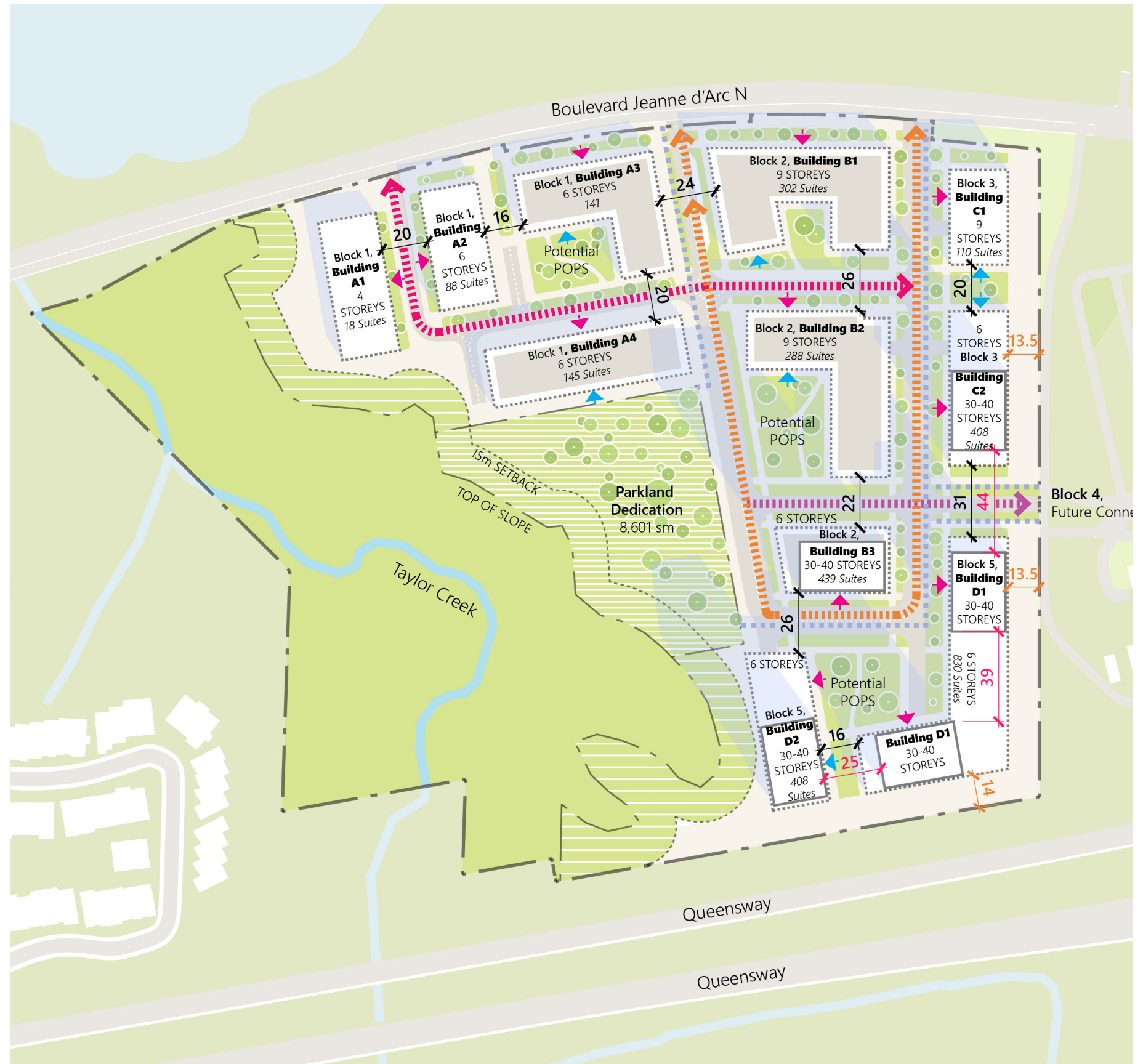



# Complete Streets

## 4 | Streetscape Approach

Complete streets are streets that are designed and operated to be safe, comfortable, and convenient for all users, including pedestrians, bicyclists, motorists, and transit riders of all ages and abilities. Safety is a critical consideration when designing complete streets. This might involve adding traffic calming measures, such as speed humps or chicanes, to slow down traffic, as well as adding lighting, improving visibility, and reducing the number of conflict points between users. Dedicated bike lanes, sidewalks, and crosswalks, as well as reducing travel lane widths or adding medians to slow traffic, increase the safety of pedestrians and cyclists. Complete streets should be designed to be accessible to all users, regardless of age, ability, or income. This might involve adding curb ramps, tactile warning strips, and other features to assist those with disabilities, as well as designing sidewalks and crosswalks to accommodate strollers, wheelchairs, and mobility devices. Complete streets can also incorporate green infrastructure elements, such as trees, rain gardens, or bioswales, to manage stormwater and provide ecological benefits. These elements can also help create a more attractive and pleasant streetscape. The goal is to create streets that are safe, accessible, and comfortable for all users, and that support a vibrant and sustainable community.





# Approach to Streetscape

## 4 | Streetscape Approach

The streetscape is an important aspect of the development as it shapes the overall character of the community. The streetscape should be designed with a pedestrian orientation in mind, it should be welcoming, accessible, and safe for pedestrians. This might include features such as wide sidewalks, street trees, benches, lighting, and wayfinding signage. In addition to accommodating pedestrians, the streetscape should also accommodate other forms of active transportation, such as bicycling and scootering. This might include bike lanes, bike parking, and dedicated spaces for shared mobility devices. The streetscape should be designed to accommodate a variety of active ground-floor uses, such as retail, offices and amenities. The goal is to create a vibrant, safe, and welcoming environment that supports a variety of activities and uses, and that reflects the values and aspirations of the community.

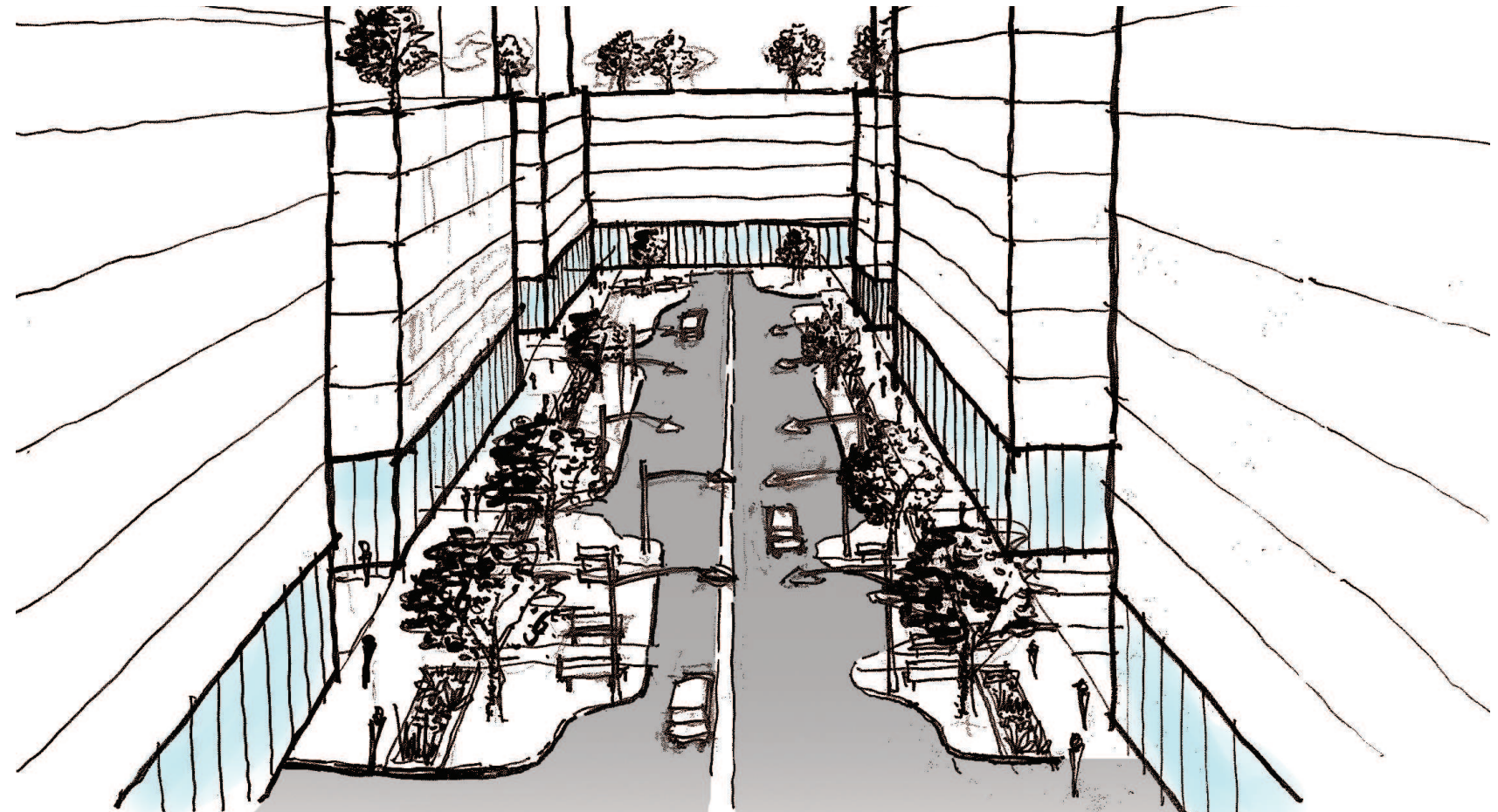



# Approach to Gateway

## 4 | Streetscape Approach

The Gateway is one of the primary entry points to the site and is likely to form the first phase of development and will therefore act as a preview of the community. Enhanced streetscape conditions will be a natural focal point, encouraging and drawing pedestrians and commuters to the area. The mix of complementary programs such as office, retail, and residential uses within the site will become an integral part of the day-to-day life of the community.





1. STANDARD CROSS-SECTIONS TO BE READ IN CONJUNCTION WITH THE GENERAL STANDARD CROSS-SECTION NOTES AND OTHER APPLICABLE CITY AND UTILITY PLANS AND DETAILS.
2. CONCRETE CURBS TO BE CONSTRUCTED AS PER CITY OF OTTAWA STANDARD DETAILS.
3. TYPICAL FRONT YARD SETBACK IS TO BE CLEAR AND UNENCUMBERED OF ANY SUBSURFACE BUILDING ENCROACHMENTS.
4. FIRE HYDRANTS TO BE LOCATED ON THE WATERMAIN SIDE OF THE STREET.
5. CATCH BASINS TO BE PER CITY OF OTTAWA DETAIL S2.
6. GAS MAIN SHALL HAVE A MINIMUM OF 0.6M CLEARANCE FROM STRUCTURES (E.G. CATCH BASINS AND HYDRANTS) AND 1.2 M FROM TREE ROOT BALL.
7. STREETLIGHTS CAN BE LOCATED ON EITHER SIDE OF THE RIGHT-OF-WAY.
8. GAS MAIN SHALL HAVE A MINIMUM OF 0.6 M CLEARANCE FROM STRUCTURES (E.G. CATCH BASINS AND HYDRANTS) AND 1.2 M FROM TREE ROOT BALL.
9. JOINT-USE UTILITY TRENCH (JUT) UNDER SIDEWALK AS PER DETAIL UDS0049 (REV 22) HELD BY OTTAWA HYDRO.
10. GRADE LEVEL BOX (GLB) AS DRAWN SHOWS GLB3660. EXACT LOCATION TO BE CONFIRMED. THIS CROSS SECTION TO BE USED IF CONCRETE ENCASED HYDRO DUCT OR ANOTHER SEPARATE UTILITY DUCT IS REQUIRED. IF CONCRETE ENCASED HYDRO DUCT IS UTILIZED, INSTALLATION AS PER DETAIL UDS0051.
11. WHEN CONCRETE DUCT BANKS ARE REQUIRED, ADDITIONAL CLEARANCE IS REQUIRED FOR THE INSTALLATION OF A 2.2M X 4.0M MAINTENANCE HOLE PER OTTAWA HYDRO DETAIL UCS0014. LOCATIONS TO BE DETERMINED DURING DESIGN PHASE.
12. TREE CLEARANCES TO HYDRO OTTAWA PLANT SHALL FOLLOW GCS0038.
13. CLEARANCES SHOWN ARE MINIMUMS.

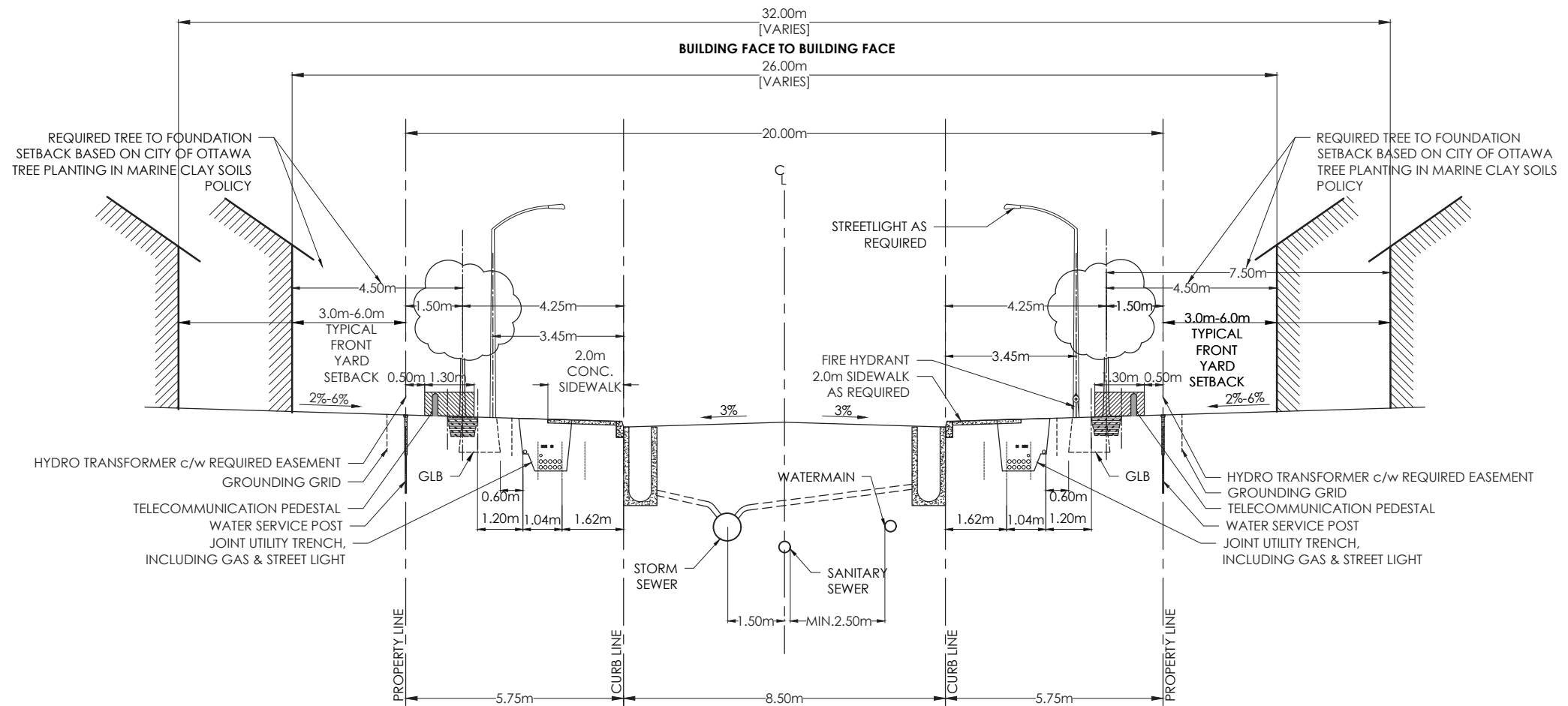

## 20.0m ROW CROSS SECTION

REV. DATE: AUG. 2022
DWG. No. ROW-20.0

# Site Sections

5 | Massing - Height, Density & Transition

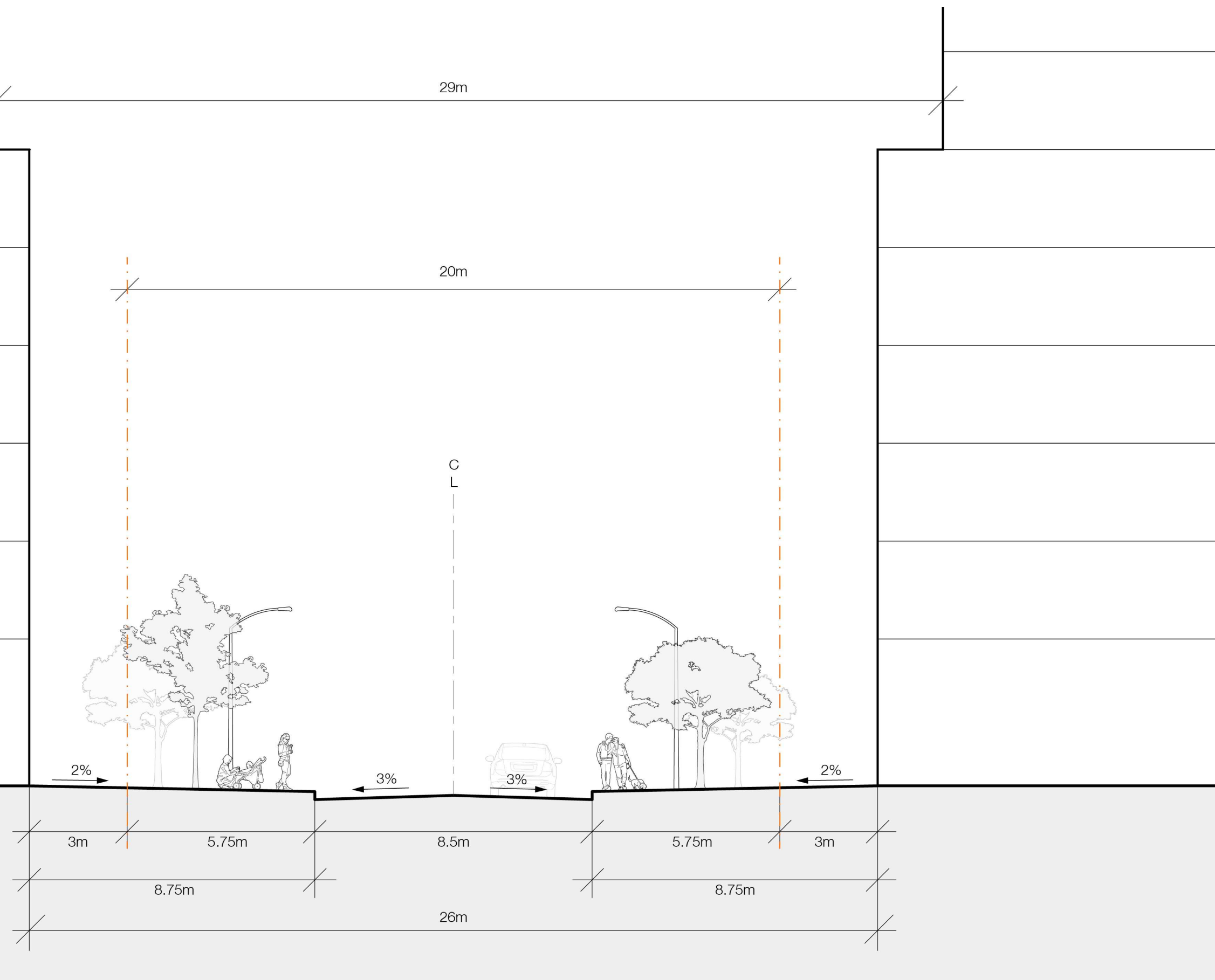
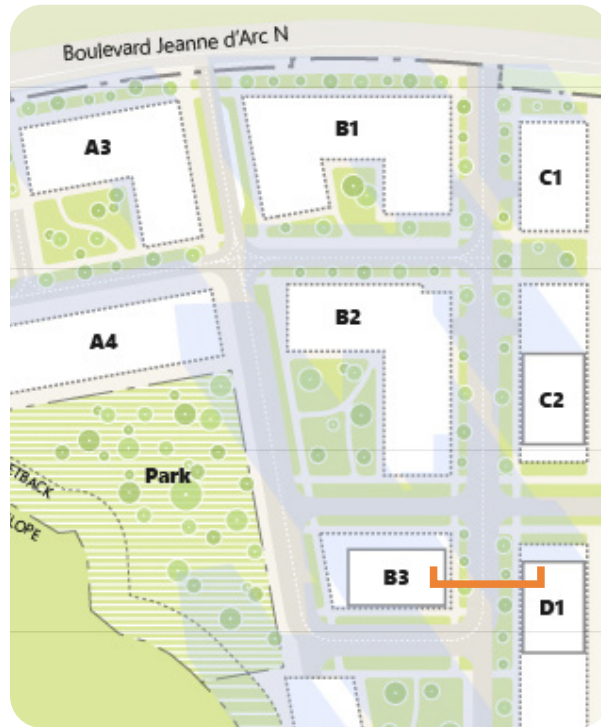

# Site Sections

5 | Massing - Height, Density & Transition

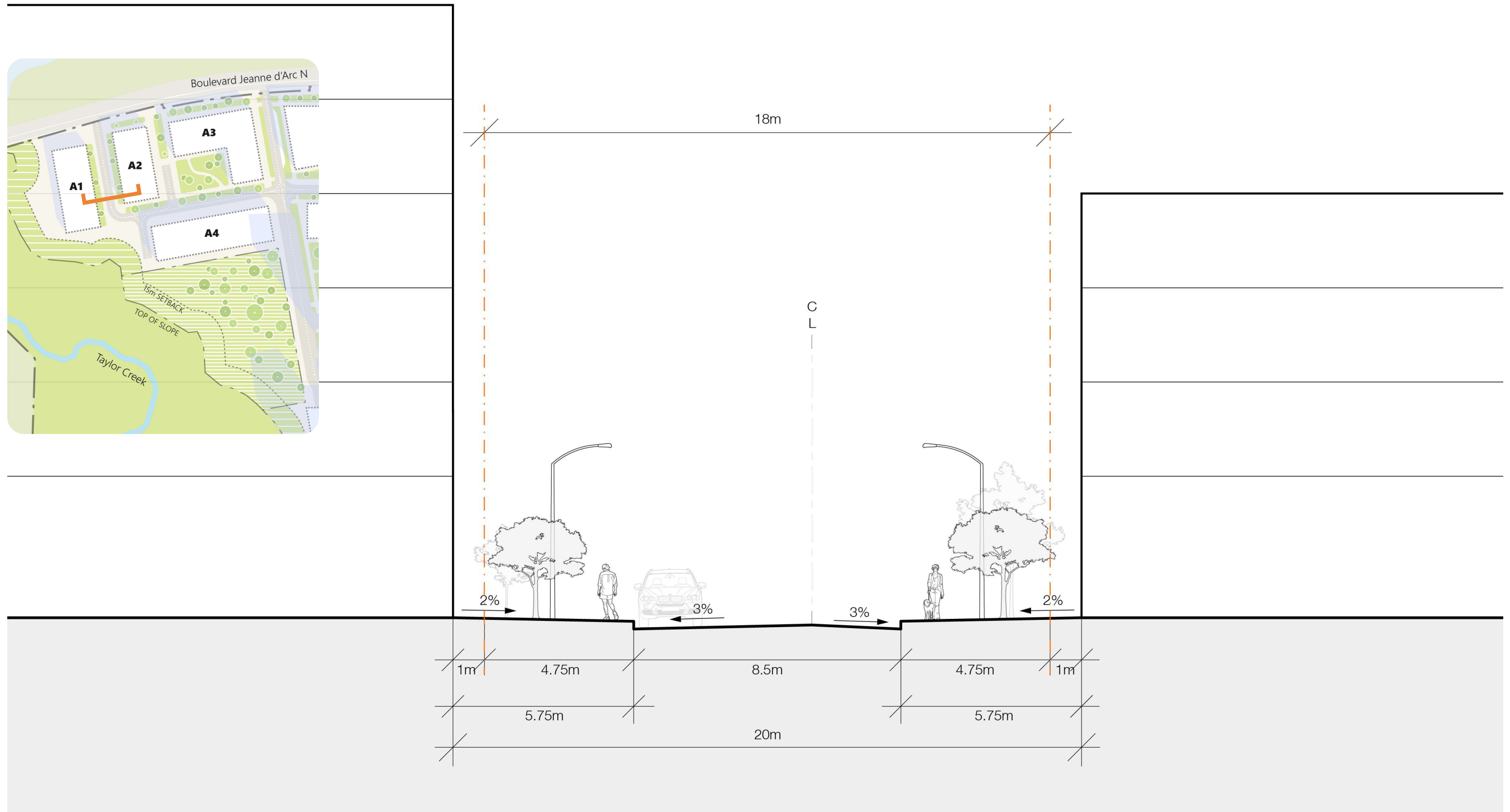



# Site

5 | Massing - Height, Density & Transition

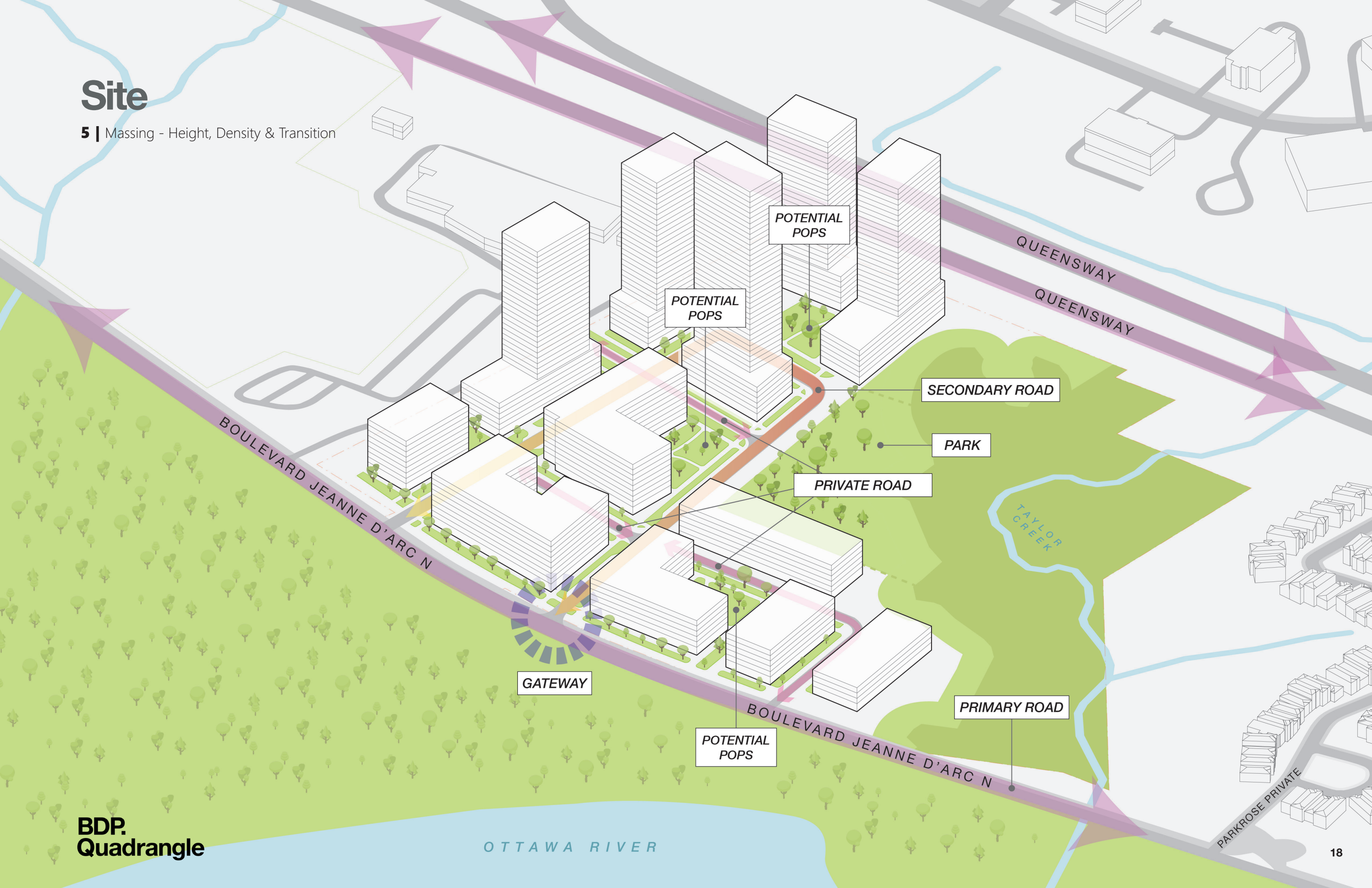



# Site

5 | Massing - Height, Density & Transition

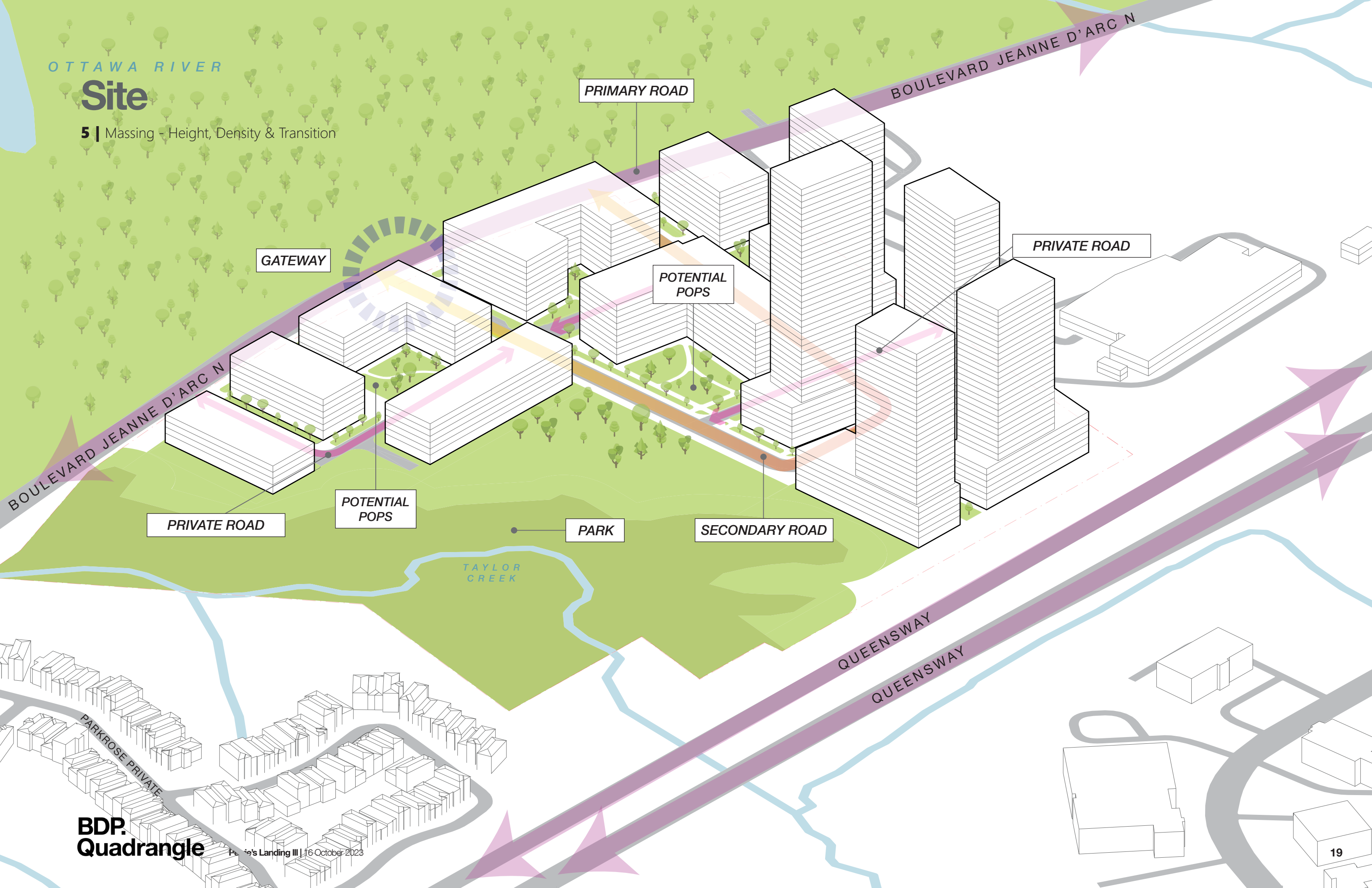

PRIMARY ROAD

BOULEVARD JEANNE D'ARC N

PRIVATE ROAD

GATEWAY

POTENTIAL POPS

BOULEVARD JEANNE D'ARC N

PRIVATE ROAD

POTENTIAL POPS

PARK

SECONDARY ROAD

TAYLOR CREEK

QUEENSWAY

QUEENSWAY



# Approach to Podium

## 6 | Architectural Expression

The massing of the podium determines the overall size, shape, and visual impact of the building. Several approaches can achieve the desired result of breaking down the building into smaller components to create a cohesive design. Façade articulation breaks up the massing of the building using a variety of materials, colors, textures, and forms to create a visually interesting façade that reduces the perceived scale of the building. Setbacks and terracing can also be used to create a more visually interesting and transition of massing while also providing terraces or green spaces for the residents. The massing and design should also consider the scale of the surrounding buildings and how the podium will interact with and contribute to the streetscape.





# Approach to Tower

## 6 | Architectural Expression

The towers will be highly visible from the Queensway and should be designed with consideration to views. The facades should be visually interesting and materials used should take into consideration the surrounding context. The buildings should offer a range of unit sizes and layouts to accommodate different family sizes and lifestyles. Common areas and amenities should be designed to promote social interaction and community-building. Minimizing the appearance of mechanical penthouses and integrating and screening any rooftop equipment will ensure a cohesive design approach. Green roofs and rooftop amenities should also be considered.





# Approach to Townhouse

## 6 | Architectural Expression

Townhouses are designed to optimize space while maintaining a high level of functionality. A clean, contemporary aesthetic that emphasizes simplicity and minimalism. This can be achieved through the use of sleek materials, such as glass, steel, and concrete, with simple geometric shapes.

Large windows and skylights should be used to maximize natural light and create a bright, open feeling and outdoor living spaces, such as rooftop terraces or balconies, provide additional living space and allow residents to connect with nature.





# Site, Orientation, Massing

## 7 | Sustainability Measures

Site orientation and massing are important considerations in the design of buildings. Site orientation refers to the direction in which a building is oriented on its site. The orientation of a building can have a significant impact on its energy efficiency and overall sustainability. In general, a building should be oriented to maximize passive solar gain, which means that the building should be designed to capture and retain as much solar energy as possible during the winter months, and to minimize solar gain during the summer months. This can be achieved through careful placement of windows, the use of shading devices, and the careful placement of the building on the site. Massing refers to the shape and form of a building. The massing of a building can also have a significant impact on its energy efficiency and overall sustainability. Buildings with compact, efficient shapes and forms are generally more energy efficient than those with complex, irregular shapes. This is because efficient buildings have a smaller surface area relative to their volume, which means that they lose less energy through their exterior walls and roof.

Sustainable measures refer to the strategies and technologies that can be used to make buildings more sustainable and can help reduce a building's environmental impact, lower energy and water consumption, as well as improve indoor air quality and comfort.

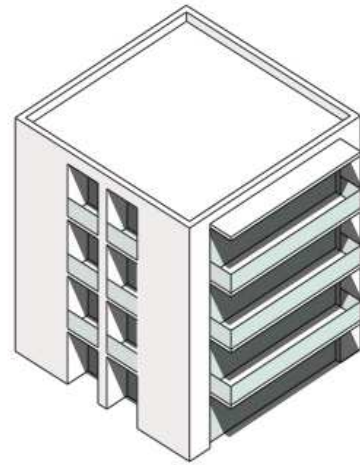

**Locate projected balconies on South and inset on East and West for passive self-shading in summer and free heat in winter.**

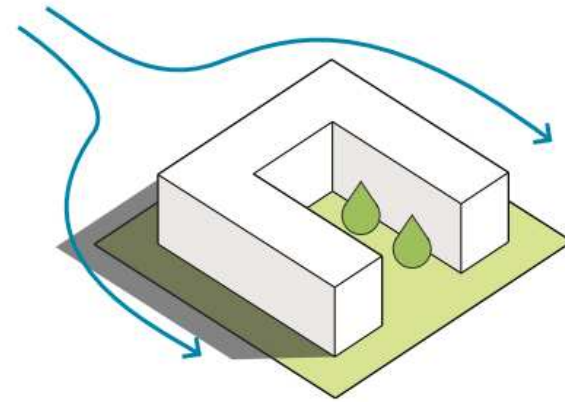

**Built form can be used for wind protection and solar shading.**

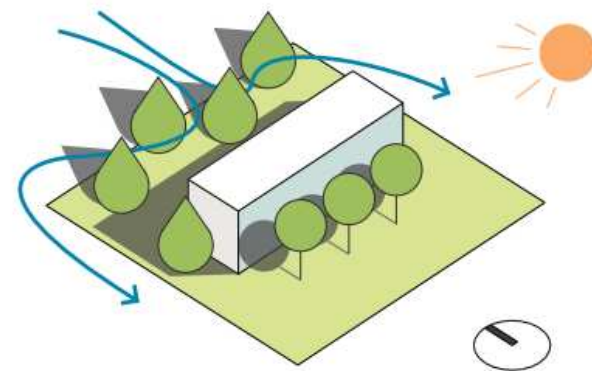

**Use coniferous trees to protect from winter wind and deciduous trees to protect from summer sun.**

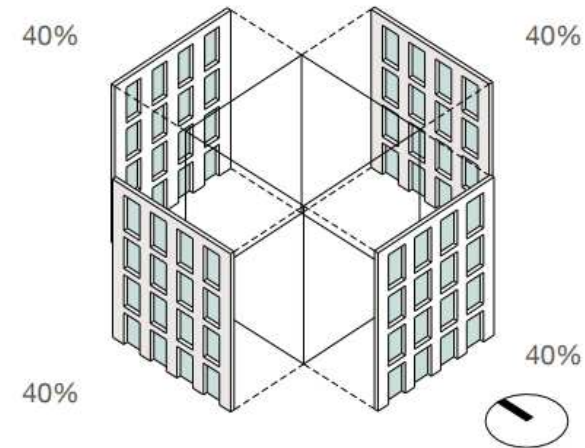

**Keep the overall window to wall ratio to 40%.**

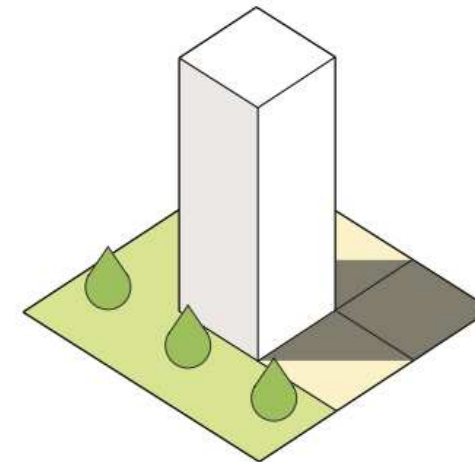

**Be mindful of shadow impacts on outdoor spaces.**

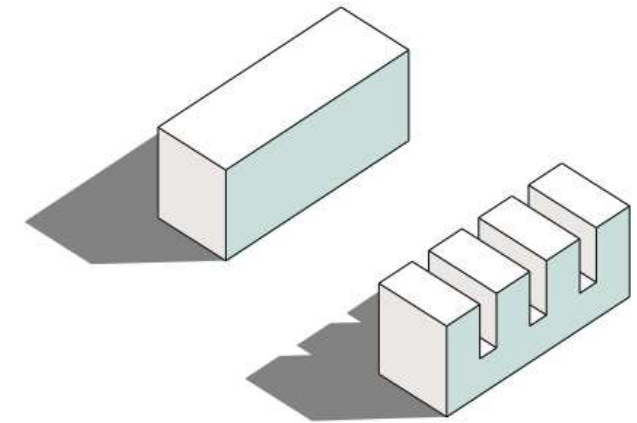

**Less envelope = less heat loss  
More envelope = sun & air penetration  
Balance the two**

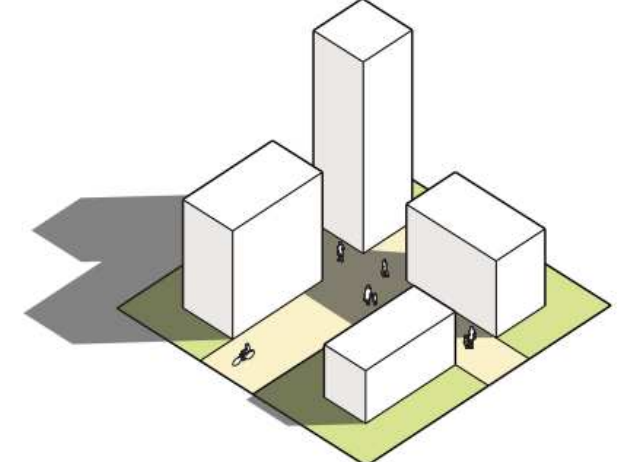

**Encourage mid-block connections.**

# Potential Passive Systems + Renewable Energy

## 7 | Sustainability Measures

Passive systems are a type of energy-efficient design that can be incorporated into buildings to reduce the need for heating, cooling, and artificial lighting. Passive design uses natural energy sources, such as the sun, wind, and vegetation, to maintain a comfortable indoor environment without the use of active mechanical systems. Buildings can be oriented to maximize sunlight during the winter months and minimize it during the summer. Shading devices, such as awnings, can also be used to reduce the amount of direct sunlight entering a building. Well-insulated buildings retain heat during the winter and stay cool during the summer, reducing the need for artificial heating and cooling. Properly designed windows and ventilation systems can allow for natural air circulation, reducing the need for artificial cooling.

Renewable energy refers to energy that is generated from natural resources that are replenished over time and do not deplete, such as sunlight, wind, water, and geothermal heat. Renewable energy is often used as an alternative to non-renewable energy sources such as fossil fuels and can help reduce greenhouse gas emissions, improve energy security, and promote sustainable economic development.

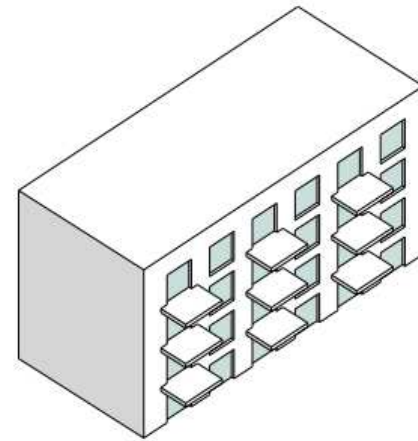

Reduce balconies to 1/3 the length of the facade.

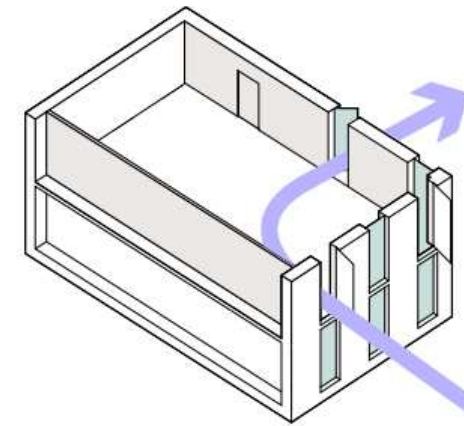

Encourage cross ventilation.

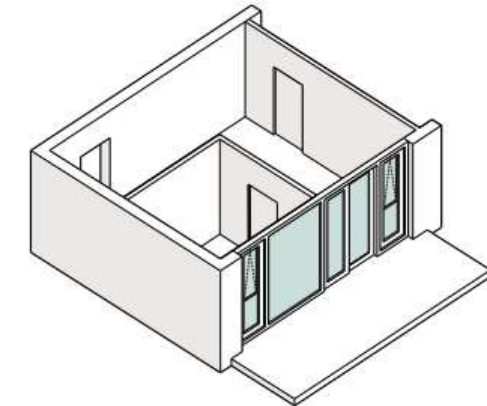

Provide operable windows in every room.



Connect to district energy systems where available

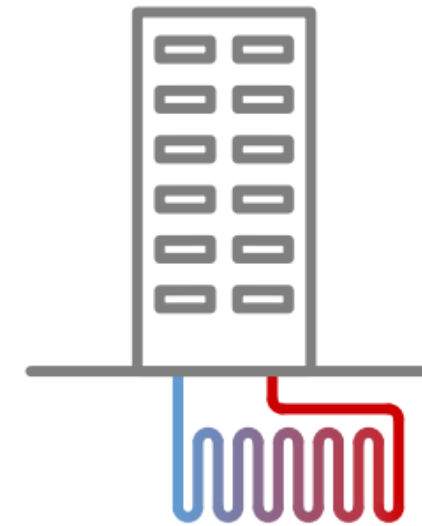

Geothermal/ground source heat pumps are efficient and reduce operational carbon

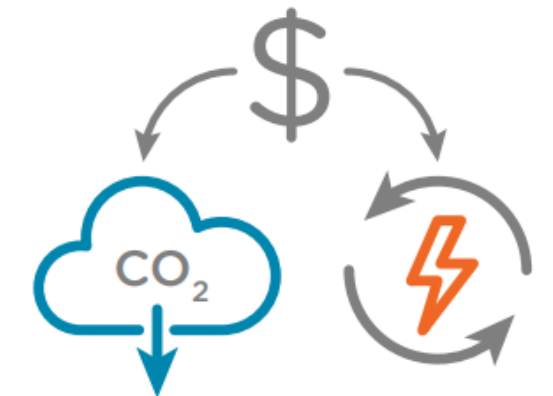

Purchase carbon offsets and renewable energy credits



# June Shadow Studies

8 | Sun Shadow Studies



June 21 | 8:00 am



# June Shadow Studies

8 | Sun Shadow Studies



June 21 | 9:00 am



# June Shadow Studies

8 | Sun Shadow Studies



June 21 | 10:00 am



# June Shadow Studies

8 | Sun Shadow Studies



June 21 | 11:00 am



# June Shadow Studies

8 | Sun Shadow Studies



June 21 | 12:00 pm



# June Shadow Studies

8 | Sun Shadow Studies



June 21 | 1:00 pm



# June Shadow Studies

8 | Sun Shadow Studies



June 21 | 2:00 pm



# June Shadow Studies

8 | Sun Shadow Studies



June 21 | 3:00 pm



# June Shadow Studies

8 | Sun Shadow Studies



June 21 | 4:00 pm



# June Shadow Studies

8 | Sun Shadow Studies



June 21 | 5:00 pm



# June Shadow Studies

8 | Sun Shadow Studies

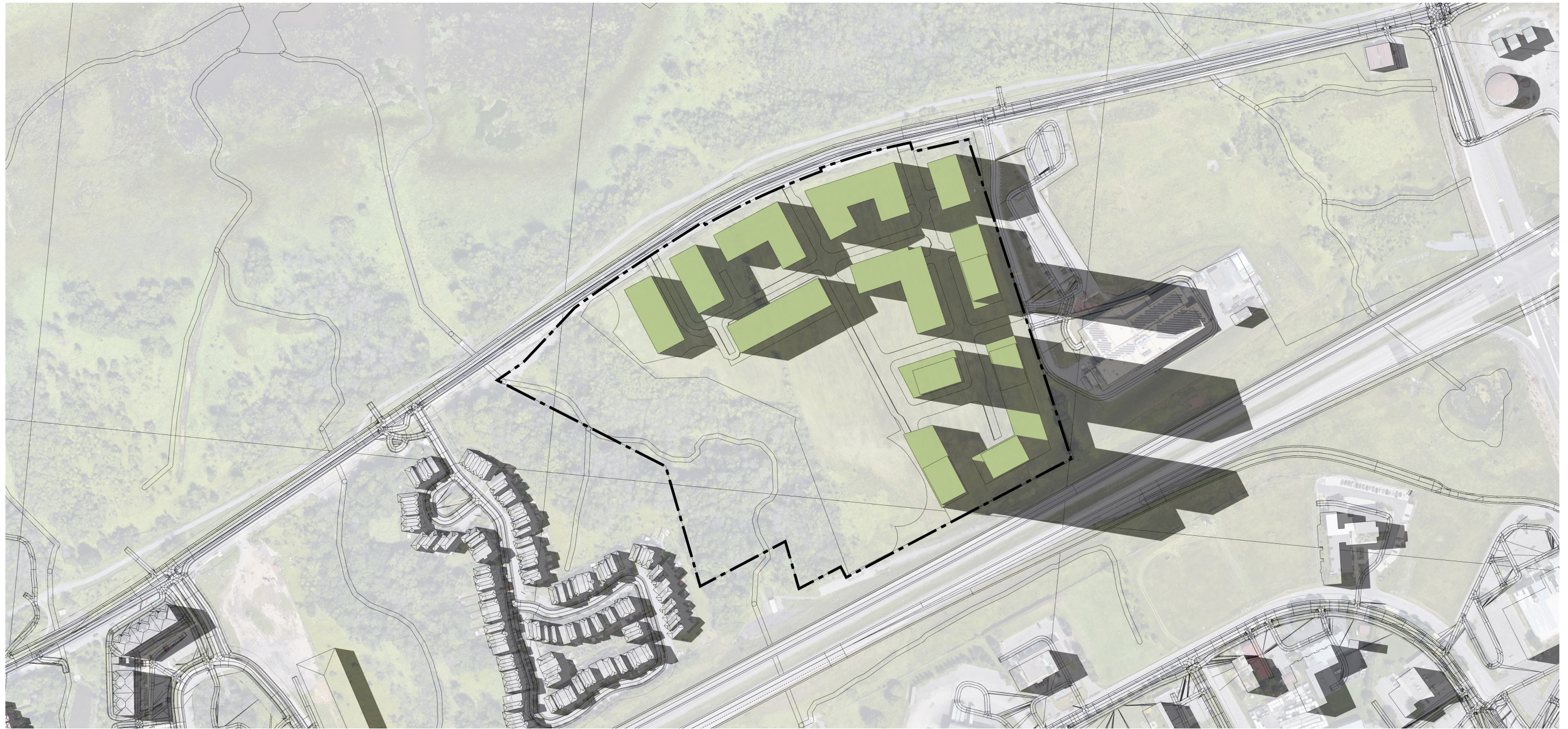

June 21 | 6:00 pm



# June Shadow Studies

8 | Sun Shadow Studies



June 21 | 7:00 pm



# September Shadow Studies

8 | Sun Shadow Studies



September 21 | 8:00 am



# September Shadow Studies

8 | Sun Shadow Studies



September 21 | 9:00 am



# September Shadow Studies

8 | Sun Shadow Studies



September 21 | 10:00 am



# September Shadow Studies

8 | Sun Shadow Studies



September 21 | 11:00 am



# September Shadow Studies

8 | Sun Shadow Studies



September 21 | 12:00 pm



# September Shadow Studies

8 | Sun Shadow Studies



September 21 | 1:00 pm



# September Shadow Studies

8 | Sun Shadow Studies



September 21 | 2:00 pm



# September Shadow Studies

8 | Sun Shadow Studies



September 21 | 3:00 pm



# September Shadow Studies

8 | Sun Shadow Studies

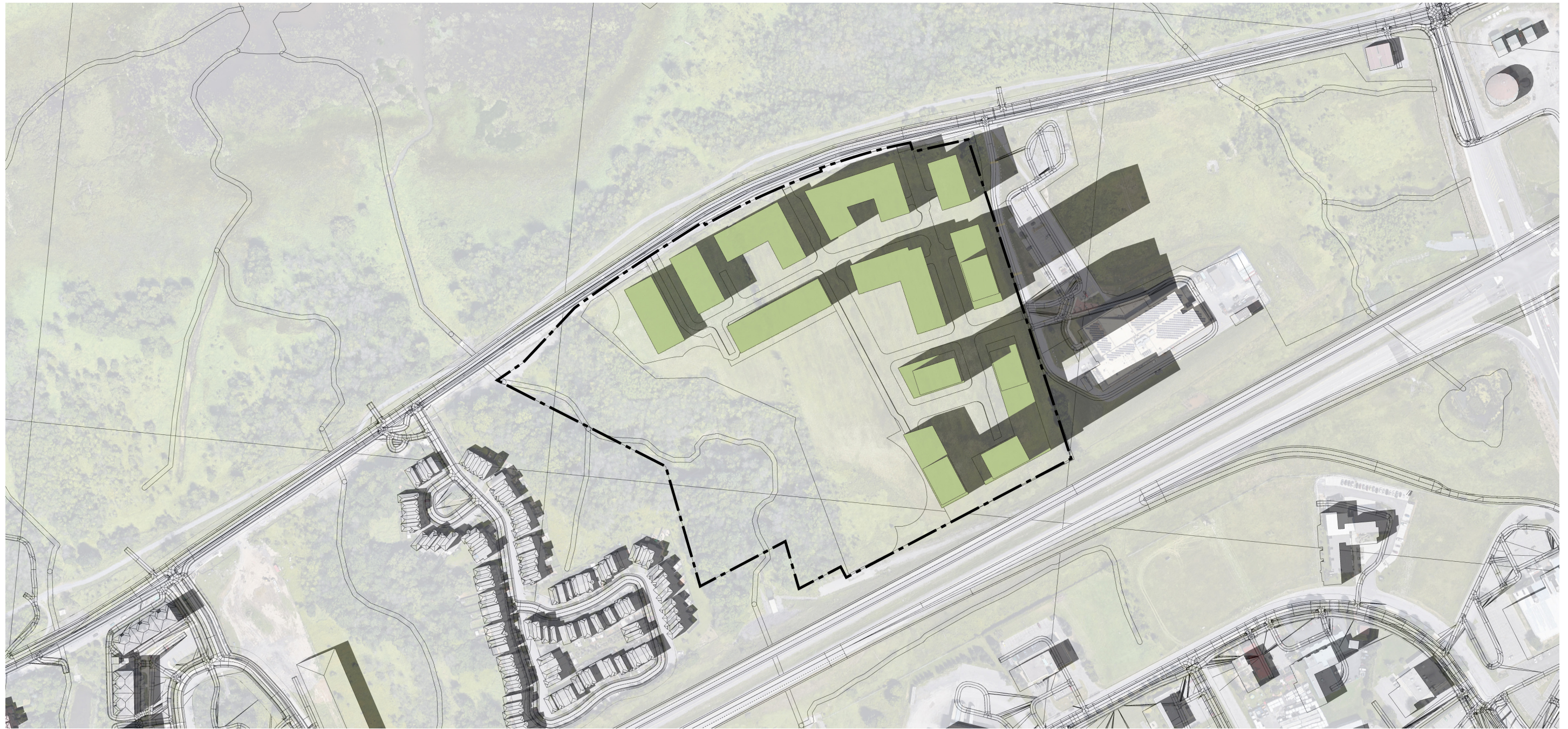

September 21 | 4:00 pm



# September Shadow Studies

8 | Sun Shadow Studies



September 21 | 5:00 pm



# September Shadow Studies

8 | Sun Shadow Studies



September 21 | 6:00 pm



# December Shadow Studies

8 | Sun Shadow Studies

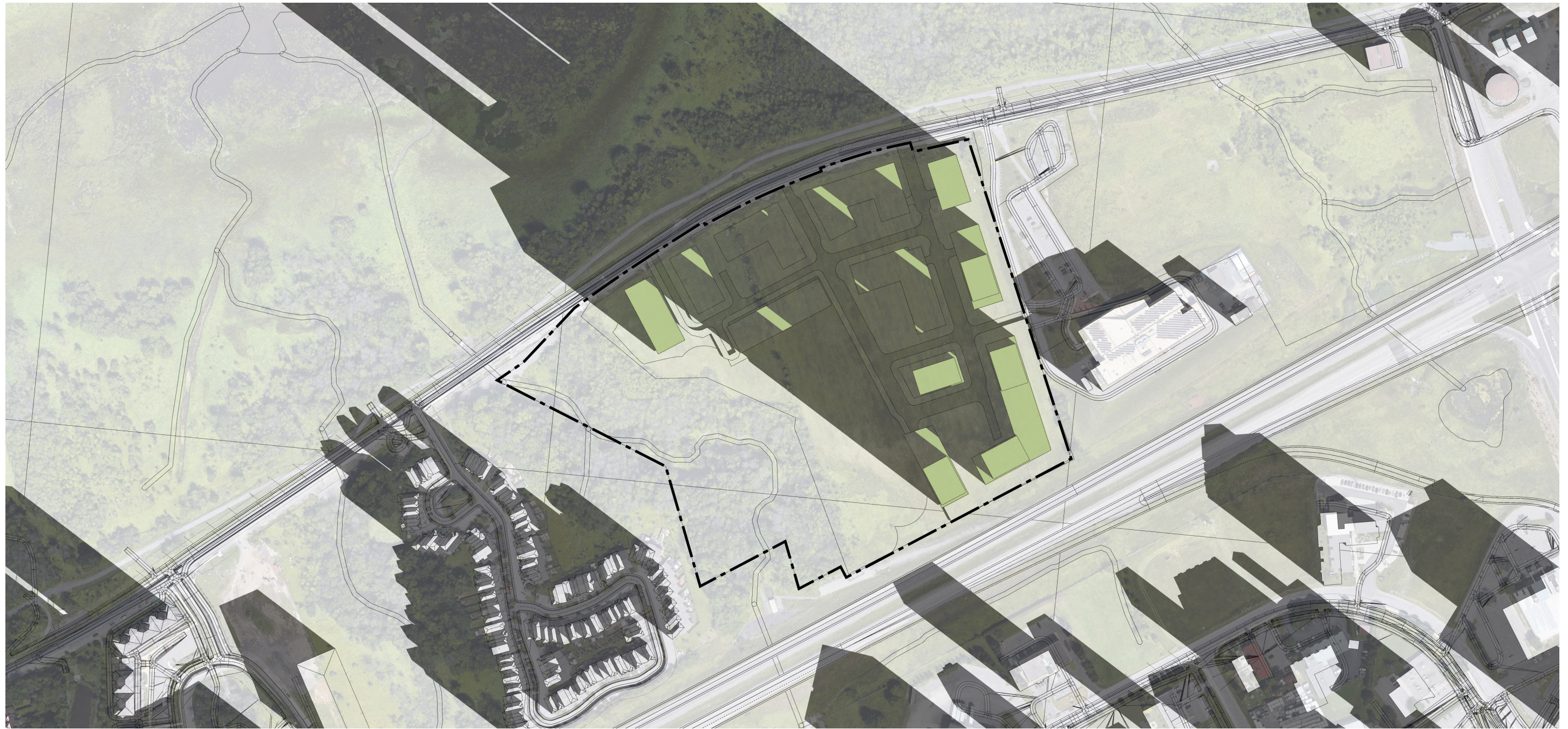

December 21 | 9:00 am



# December Shadow Studies

8 | Sun Shadow Studies



December 21 | 10:00 am



# December Shadow Studies

8 | Sun Shadow Studies



December 21 | 11:00 am



# December Shadow Studies

8 | Sun Shadow Studies



December 21 | 12:00 pm



# December Shadow Studies

8 | Sun Shadow Studies



December 21 | 1:00 pm



# December Shadow Studies

8 | Sun Shadow Studies



December 21 | 2:00 pm



# December Shadow Studies

8 | Sun Shadow Studies

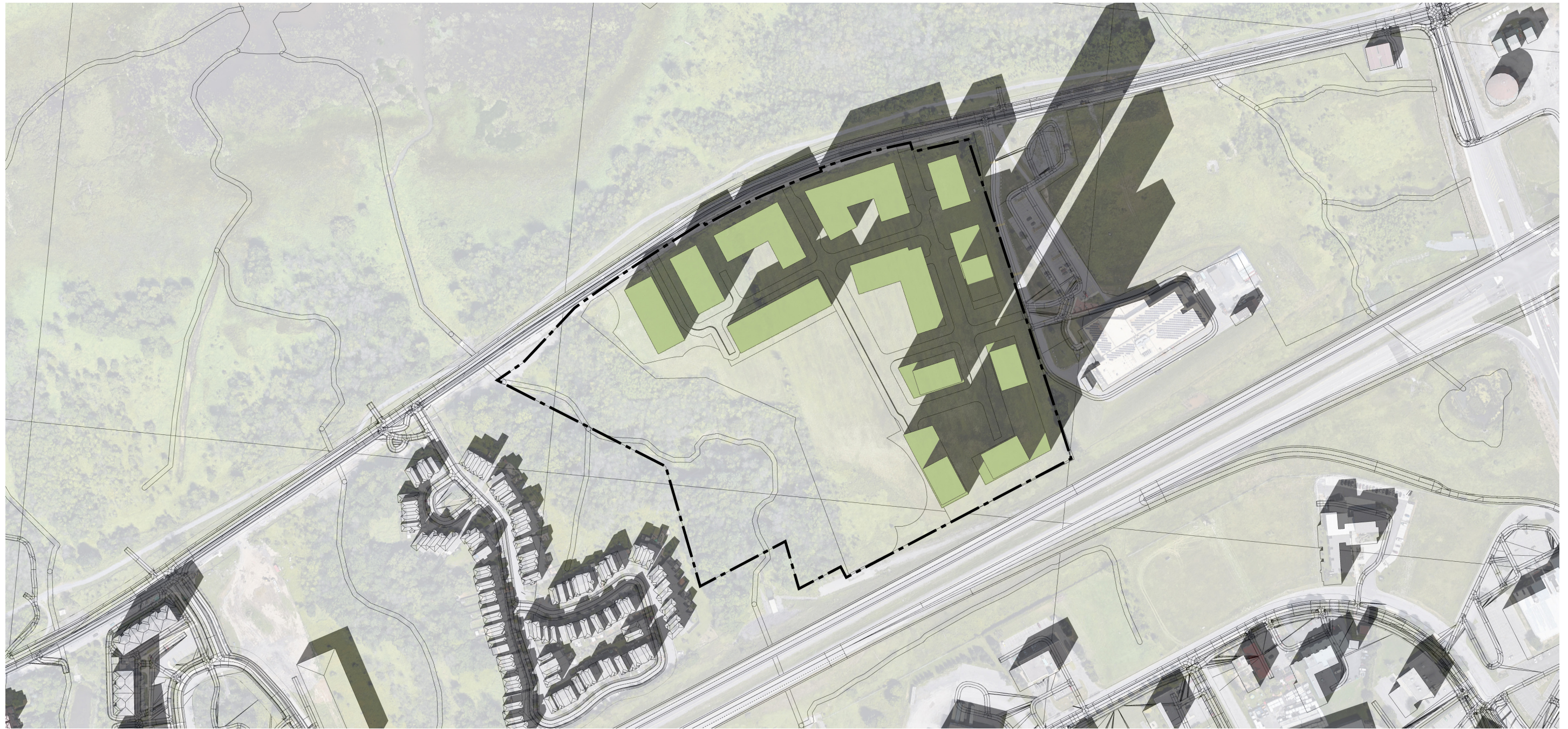

December 21 | 3:00 pm