



**Heatherington Road Subdivision: 1770
Heatherington Road Functional
Servicing Report**

Stantec Project No. 160401774

May 17, 2024

Prepared for:

Attn: Mary Dickinson
Affordable Housing Branch – Housing Services
Community and Social Services Dept.
City of Ottawa

Prepared by:

Stantec Consulting Ltd.
400-1331 Clyde Avenue
Ottawa ON K2C 3G4



Revision	Description	Author		Quality Check		Independent Review	
1	1 st Submission	2023-09-21	KC	2024-05-17	DT	2024-05-14	SG



HEATHERINGTON ROAD SUBDIVISION: 1770 HEATHERINGTON ROAD FUNCTIONAL SERVICING REPORT

This document entitled Heatherington Road Subdivision: 1770 Heatherington Road Functional Servicing Report was prepared by Stantec Consulting Ltd. ("Stantec") for the account of City of Ottawa (the "Client"). Any reliance on this document by any third party is strictly prohibited. The material in it reflects Stantec's professional judgment in light of the scope, schedule and other limitations stated in the document and in the contract between Stantec and the Client. The opinions in the document are based on conditions and information existing at the time the document was published and do not take into account any subsequent changes. In preparing the document, Stantec did not verify information supplied to it by others. Any use which a third party makes of this document is the responsibility of such third party. Such third party agrees that Stantec shall not be responsible for costs or damages of any kind, if any, suffered by it or any other third party as a result of decisions made or actions taken based on this document.

Prepared by _____

Krystian Chochlinski, EIT



Reviewed by _____

Dustin Thiffault, P.Eng.



Approved by _____

Sheridan Gillis



Table of Contents

1.0	INTRODUCTION.....	1.1
2.0	REFERENCE DOCUMENTS.....	2.2
3.0	POTABLE WATER SERVICING.....	3.1
3.1	BACKGROUND.....	3.1
3.2	PROPOSED WATERMAIN SIZING AND LAYOUT.....	3.1
3.2.1	Connections to Existing Infrastructure.....	3.1
3.2.2	Domestic Water Demands.....	3.1
3.2.3	Fire Flow.....	3.2
3.3	LEVEL OF SERVICE.....	3.2
3.3.1	Allowable Pressures.....	3.2
4.0	WASTEWATER SERVICING.....	4.1
4.1	BACKGROUND.....	4.1
4.2	DESIGN CRITERIA.....	4.1
4.3	FUNCTIONAL SANITARY SERVICING DESIGN.....	4.1
5.0	STORMWATER MANAGEMENT AND STORM SERVICING.....	5.1
5.1	DESIGN CRITERIA AND CONSTRAINTS.....	5.1
5.2	PROPOSED CONDITIONS.....	5.2
5.2.1	Quality Control.....	5.3
5.3	WATER BALANCE – INFILTRATION REQUIREMENTS.....	5.4
6.0	GEOTECHNICAL CONSIDERATIONS AND GRADING.....	6.1
6.1	GEOTECHNICAL INVESTIGATION.....	6.1
6.1.1	Groundwater Control.....	6.1
6.2	FUNCTIONAL GRADING PLAN.....	6.2
7.0	APPROVALS.....	7.1
8.0	UTILITIES.....	8.1
9.0	EROSION CONTROL.....	9.1
10.0	CONCLUSIONS AND RECOMMENDATIONS.....	10.1
10.1	POTABLE WATER SERVICING.....	10.1
10.2	WASTEWATER SERVICING.....	10.1
10.3	STORMWATER MANAGEMENT AND SERVICING.....	10.1
10.4	GRADING, EROSION AND SEDIMENT CONTROL.....	10.2
10.5	APPROVALS/PERMITS.....	10.2
10.6	UTILITIES.....	10.3



LIST OF TABLES

Table 1. Residential Water Demands 3.2
Table 2. Summary of Proposed Sanitary Peak Flows 4.2
Table 3. Site Allowable Peak Release Rates..... 5.2
Table 4. Summary of Proposed Storage and Peak Flow Requirements 5.3

LIST OF FIGURES

Figure 1: Heatherington Road Subdivision – 1770 Heatherington Road Draft Plan Area 1.1

LIST OF APPENDICES

APPENDIX A – POTABLE WATER SERVICING A.1
A.1 Boundary Conditions A.1
A.2 Domestic Water Demand Calculations A.2

APPENDIX B – WASTEWATER SERVICING CALCULATIONS B.1
B.1 Sanitary Sewer Design Sheet..... B.1

APPENDIX C – STORMWATER MANAGEMENT C.1
C.1 Storm Sewer Design Sheet C.1
C.2 Runoff Coefficient Calculations C.2
C.3 OGS Unit Sizing Calculations..... C.3
C.4 Background Excerpts C.4

APPENDIX D – GEOTECHNICAL INVESTIGATION..... D.1
D.1 Geotechnical Report Excerpts..... D.1



Introduction

1.0 INTRODUCTION

The City of Ottawa has retained Stantec Consulting Ltd. to prepare this Functional Servicing Report for the 1770 Heatherington Road Subdivision. The subject site is located within the City of Ottawa, bound by Angela Private to the south, developed mixed-use/commercial land to the west, Walkey Road to the north, and Heatherington Road to the east as illustrated in **Figure 1** below.

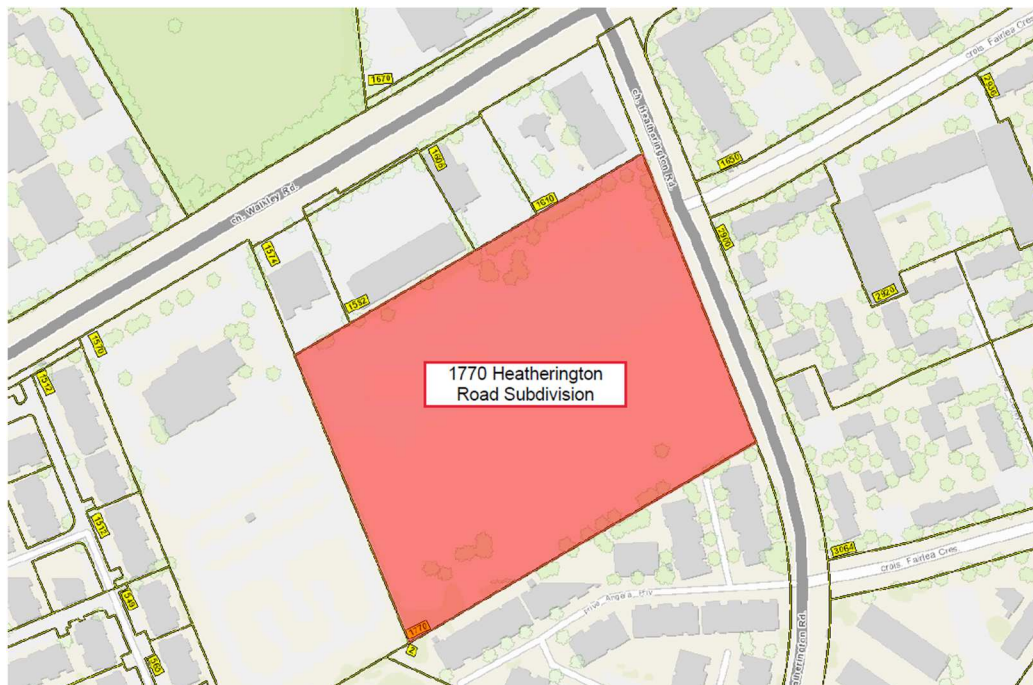

Figure 1: Heatherington Road Subdivision – 1770 Heatherington Road Draft Plan Area

The existing land consists of the newly constructed Taggart Parkes Family Clubhouse – Boys & Girls Club of Ottawa encircled by the proposed site area. The parcel is currently zoned IG1[2663], general industrial zone. The site is approximately 2.73 ha in area, excluding the Boys & Girls Club of Ottawa land. The proposed subdivision will ultimately consist of two four-storey apartment buildings, five townhome blocks, four stacked townhome blocks, three semi-detached dwellings and a park. The site will be serviced by connections to the mains on Heatherington Road as shown on **Drawing SSP-1**. The intent of this report is to provide a servicing scenario for the site that is free of conflicts, provides on-site servicing in accordance with City of Ottawa design guidelines, and utilizes the existing local infrastructure in accordance with the guidelines outlined in background documents and as per consultation with City of Ottawa staff.



2.0 REFERENCE DOCUMENTS

The following documents were referenced in the preparation of this report:

- *City of Ottawa Sewer Design Guidelines*, 2nd Edition, City of Ottawa, October 2012.
- *City of Ottawa Design Guidelines – Water Distribution*, First Edition, Infrastructure Services Department, City of Ottawa, July 2010.
- *Technical Bulletin ISTB-2014-02 Revision to Ottawa Design Guidelines – Water*, City of Ottawa, May 2014, and subsequent *Technical Bulletins*.
- *Technical Bulletin PIEDTB-2016-01 Revisions to Ottawa Design Guidelines – Sewer*, City of Ottawa, September 2016, and subsequent *Technical Bulletins*.
- *Sawmill Creek Subwatershed Study* – City of Ottawa, 2003.



3.0 POTABLE WATER SERVICING

3.1 BACKGROUND

The proposed residential development will include 36 freehold townhome/semi-detached units, 5 future residential site plan blocks (totaling 122 apartments/stacked townhouse units), and a park.

The proposed development is located within Zone 2W2C of the City of Ottawa water distribution system. The development will be serviced by the existing 200 mm diameter municipal watermain on Heatherington Road. **Drawing SSP-1** shows the functional watermain layout. Two tee connections to the existing watermain along Heatherington Road will provide a loop for the street. A watermain extension from the existing 400 mm watermain on Walkley Road connecting to the existing stub on Heatherington Road is being proposed to increase flow.

3.2 PROPOSED WATERMAIN SIZING AND LAYOUT

3.2.1 Connections to Existing Infrastructure

The proposed watermain alignment and sizing for the development is demonstrated on **Drawing SSP-1**. A 200 mm diameter watermain is proposed to loop within the street and watermain extension from Walkley Road is proposed to connect to the stub on Heatherington Road. The connection points are as follows:

- 1) A 200 mm diameter watermain will loop and connect to the existing 200 mm watermain along Heatherington Road via tee connections.
- 2) A 200 mm diameter watermain will connect to the existing 400 mm diameter watermain on Walkley Road and tie into the existing 200 mm diameter watermain stub on Heatherington Road to increase available flows. The option to increase the watermain diameter to 300 mm will be explored and considered at the detailed design phase.

3.2.2 Domestic Water Demands

The 1770 Heatherington Road development will contain a total of 36 freehold townhome/semi-detached units, 5 future residential site plan blocks (totaling 122 apartments/stacked townhouse units), and a park having a total estimated population of 343 persons. Refer to **Appendix A.2** for detailed domestic water demand calculations.

Water demands for the development were calculated using the City of Ottawa's Water Distribution Design Guidelines. For residential developments, the average day (AVDY) per capita water demand is 280 L/cap/d. For maximum day (MXDY) demand, AVDY was multiplied by a factor of 2.5 and for peak hour (PKHR) demand, MXDY was multiplied by a factor of 2.2. The calculated residential water consumption is represented in **Table 1** below:



Potable Water Servicing

Table 1. Residential Water Demands

Unit Type	Units	Persons/Unit	Population	AVDY (L/s)	MXDY (L/s)	PKHR (L/s)
One-bedroom Apartments	48	1.4	67	0.22	0.54	1.20
Two-bedroom Apartment	28	2.1	59	0.19	0.48	1.05
Studio Apartment	14	1.4	20	0.06	0.16	0.36
Semi-Detached Dwelling	6	3.4	20	0.07	0.17	0.36
Stacked Townhouse	32	2.7	86	0.28	0.70	1.54
Townhouse (Row)	30	2.7	81	0.26	0.66	1.44
Existing B&G Club Ottawa Clubhouse	-		-	0.05	0.08	0.14
Proposed Park	-		-	0.10	0.16	0.28
Total Site:	158		333	1.2	2.9	6.4

3.2.3 Fire Flow

The available fire flow for the site was provided by the City of Ottawa based on the two possible watermain extension scenarios to Walkley Road. With a 200 mm diameter extension, the available fire flow would be 176 L/s, whereas a 300 mm diameter extension would provide a fire flow of 200 L/s. As per *ISDTB-2014-02*, the proposed blocks could qualify to have their fire flow capped at 10000 L/min or 166.67 L/s should they be developed as 2-storey townhomes with minimum 10m separation from adjacent units at the rear of each property.

Fire walls and/or sprinkler systems will be considered to achieve adequate fire flows within each block. The locations and number of fire walls will be confirmed in the detailed design phase. FUS fire flow calculation spreadsheets will also be completed in the detailed design phase for each block.

3.3 LEVEL OF SERVICE**3.3.1 Allowable Pressures**

The City of Ottawa Water Distribution Design Guidelines state that the desired range of system pressures under normal demand conditions (i.e. basic day, maximum day and peak hour) should be in the range of 350 to 552 kPa (50 to 80 psi) and no less than 275 kPa (40 psi) at the ground elevation in the streets (i.e. at hydrant level). The maximum pressure at any point in the distribution system in occupied areas outside of the public right-of-way is 552 kPa (80 psi). As per the Ontario Building Code (OBC) & Guide for Plumbing, if pressures greater than 552 kPa (80 psi) are anticipated, pressure relief measures are required. The maximum pressure at any point in the distribution system in unoccupied areas shall not exceed 689 kPa (100 psi). Under emergency fire flow conditions, the minimum pressure objective in the distribution system is 138 kPa (20 psi).

The boundary conditions provided by the City of Ottawa (**Appendix A.1**) demonstrate that the pressures in the Heatherington Road watermain fall within the range of target system pressures with a maximum basic day pressure of 61.7 psi and minimum peak hour pressure of 52.0 psi along the Heatherington Road



HEATHERINGTON ROAD SUBDIVISION: 1770 HEATHERINGTON ROAD FUNCTIONAL SERVICING REPORT

Potable Water Servicing

frontage. These pressures were determined by subtracting the provided minimum (123.5 m) and maximum (130.1 m) hydraulic grade lines from the approximate proposed road grades at the connection points (86.9 m at Connection 1 and 86.7 at Connection 2).

Given the functional grading of the subdivision, pressures within the development are expected to fall within the target range and pressure reducing valves are not expected to be required. A hydraulic model using H2OMAP Water will be developed as part of the detailed design of the subdivision to confirm system pressures within the roadways.

The proposed development can be adequately serviced by the 200 mm watermain along Heatherington Road. The watermains will provide sufficient fire flow to meet FUS requirements, and system pressures will fall within the City of Ottawa Water Distribution Guidelines.



4.0 WASTEWATER SERVICING

4.1 BACKGROUND

A 375 mm diameter local sanitary sewer currently run along the frontage of the proposed 1770 Heatherington Road Subdivision development. The subdivision will be serviced by a network of gravity sanitary sewers discharging to the local 375 mm diameter sanitary sewer in Heatherington Road. Two connections to the existing local sanitary sewer in Heatherington Road are proposed as shown on **Drawing SA-1**.

The segment of 375 mm sanitary sewer that will be connected to runs along Heatherington Road before being directed into a sewer easement that connects to Albion Road, and ultimately connecting to the 900 mm diameter trunk sewer on Johnston Road. Given the limited upstream tributary area to the sewer, it is anticipated that sufficient residual capacity exists within the sewer to service the proposed development. Residual capacity within the 375mm sanitary sewer is to be confirmed with City of Ottawa staff.

4.2 DESIGN CRITERIA

As outlined in the City's Sewer Design Guidelines, the following design parameters were used to calculate estimated wastewater flow rates and to preliminarily size on-site sanitary sewers:

- Minimum Full Flow Velocity – 0.6 m/s
- Maximum Full Flow Velocity – 3.0 m/s
- Manning's roughness coefficient for all smooth-walled pipes – 0.013
- Single Family / Semi-Detached Home persons per unit – 3.4
- Townhouse//Stacked Home persons per unit – 2.7
- Studio/One-Bedroom Apartment persons per unit – 1.4
- Two-bedroom Apartment persons per unit – 2.1
- Three-bedroom Apartment persons per unit – 3.1
- Extraneous Flow Allowance – 0.33 L/s/ha
- Residential Average Flows – 280 L/cap/day
- Commercial/Mixed Use Flows – 28,000 L/ha/day
- Maintenance Hole Spacing – 120m
- Minimum Cover – 2.5m
- Harmon Correction Factor – 0.8

Refer to **Appendix B.1** for the sanitary sewer design sheet for the proposed 1770 Heatherington Road development.

4.3 FUNCTIONAL SANITARY SERVICING DESIGN

Two separate runs of 200 mm diameter sanitary sewers are proposed along the roadway loop to service the 1770 Heatherington Road subdivision with two separate connections to the existing 375 mm local sanitary sewer in Heatherington Road. The proposed layout of the sanitary infrastructure is shown on



Wastewater Servicing

Drawing SA-1. Sanitary peak flows will be directed to the 375 mm diameter sanitary sewer on Heatherington Road which discharges to a 450 mm diameter concrete sanitary sewer at Albion Road which is ultimately directed to the Johnston Road trunk sewer. The connections to the existing sanitary sewer network in Heatherington Road and the associated peak flows are summarized in **Table 2.** below.

Table 2. Summary of Proposed Sanitary Peak Flows

Outlet	Cumulative Area (ha)	No. Units	Population	Total Peak Flow (L/s)
SAN1	1.49	91	201	2.8
SAN8	1.25	67	132	1.9
Total	2.74	158	333	4.7

The proposed 1770 Heatherington Road Subdivision will consist of apartment buildings, townhomes, stacked townhomes, and semi-detached dwellings. The population densities used are detailed in the design criteria section above. A residential peaking factor, based on Harmon’s Equation, was used to determine the peak design flows. An allowance of 0.33 L/s/effective gross ha (for all areas) was used to generate peak extraneous flows.

The total design peak flow for the subject site to be conveyed to the connections at the 375 mm Heatherington Road sewer is estimated at 4.7 L/s.



5.0 STORMWATER MANAGEMENT AND STORM SERVICING

The proposed development encompasses approximately 2.73 ha of land and consists of a mix of townhomes, stacked townhomes, semi-detached dwellings, and apartment buildings. The proposed development is within the Sawmill Creek subwatershed area.

5.1 DESIGN CRITERIA AND CONSTRAINTS

The *Sawmill Creek Subwatershed Study*, completed in 2003, outlines the stormwater management (SWM) criteria for the site based on pre-consultation notes included in **Appendix C.4**. Per the subwatershed study, The Rideau Valley Conservation Authority (RVCA) stated that the stormwater flow path for the site appears to bypass the Sawmill Creek stormwater monitoring facility, thus, on-site water quality control is required. The SWM criteria for the site have been established through a review of background reports and City of Ottawa Sewer Design Guidelines and is summarized as follows:

General

- Use of the dual drainage principle (City of Ottawa).
- Wherever feasible and practical, site-level measures should be used to reduce and control the volume and rate of runoff (City of Ottawa).

Storm Sewer & Inlet Controls

- Size storm sewers to convey 2-year storm event under free-flow conditions using 2012 City of Ottawa I-D-F parameters.
- Restrict inflows to the storm sewer from the proposed development to pre-development rates for the 2-year through 100-year storm events (Sawmill Creek study).
- Pre-development release rate to be determined based on a maximum runoff coefficient of 0.50. (City of Ottawa – considered as 0.52 for the Heatherington area within the Sawmill Creek study).
- 100-year Storm HGL to be a minimum of 0.30 m below building foundation footing (City of Ottawa).

Surface Storage & Overland Flow

- No rear-yard ponding volumes to be accounted for in SWM model preparation (City of Ottawa).
- Building openings to be above the 100-year water level and climate change event (100-year + 20%) water level (City of Ottawa).
- Total maximum depth of flow under static and dynamic conditions shall be less than 0.35 m (City of Ottawa).
- Quality control to be provided by on-site O.G.S. unit(s) (80% removal).
- Major system peak flows from the site to be directed to Heatherington Road and continue south, away from the high point at Walkley Road.
- Provide adequate emergency overflow conveyance off-site (City of Ottawa).



Stormwater Management and Storm Servicing

It is of note that notes for Phase 1 pre-consultation identify “Per the subwatershed study, peak flows from development sites must be controlled to the 2-year return period event, up to and including the 100-year event”. This is in contrast to the actual text of the subwatershed study which states “Control peak flows from development sites to pre-development levels, for return period events of 2 to 100 years”. It is assumed that the intent of the pre-consultation note was to follow results of the subwatershed study, and that no downstream peak flow concerns exist for the storm sewer tie-in on Heatherington Road.

Time of concentration for the pre-development site was determined via the Federal Aviation Administration (FAA) methodology based on an overall catchment length of 656 ft and average surface slope of 1.05%. An existing runoff coefficient was estimated at 0.7 based on the predominantly gravel and hardpack bare site soil surface. Per FAA methodology, the existing site time of concentration was estimated as 18.1 minutes (see **Appendix C.2** for details). The estimated peak pre-development runoff was then estimated using the rational method based on the time of concentration noted, the 2.74ha development area, and the maximum allowable pre-development runoff coefficient of 0.5. Peak allowable site release rates are identified in **Table 3** below.

Table 3. Site Allowable Peak Release Rates

Storm Event	Peak Release Rate (L/s)
2-Year	210.6
100-Year	486.2

5.2 PROPOSED CONDITIONS

The site will be serviced by the existing 675 mm diameter storm sewer along Heatherington Road. City of Ottawa staff have not identified capacity concerns relating to downstream surcharge within the Heatherington Road storm sewer. As shown on **Drawing SD-1**, runoff from the proposed development will be directed to the existing 675 mm storm sewer along Heatherington Road through one connection at the southern portion of the roadway loop, with minor system discharge limited to that from predevelopment conditions.

Runoff coefficients (C values) were calculated for each road sub-catchment area using a C of 0.20 for soft surfaces (i.e. landscaped areas) and a C of 0.90 for hard surfaces (i.e. roads, roofs, and sidewalks). Runoff coefficients for development blocks were conservatively estimated at a C of 0.70. Detailed runoff coefficient calculations have been provided in **Appendix C.2**, while the functional storm sewer design sheet has been provided in **Appendix C.1**.

Major system peak flows from the site will be directed to Heatherington Road which directs major system peak flows southwards from a high point located approximately at the intersection of Heatherington Road and Walkley Road.

The site will be designed using the “dual drainage” principle, whereby the minor (pipe) system in local roads is designed to convey the peak rate of runoff from the 2-year design storm and runoff from larger events is



Stormwater Management and Storm Servicing

conveyed by both minor (pipe) and major (overland) channels, such as roadways and walkways, safely off site without impacting proposed or existing downstream properties.

Inlet control devices (ICDs) or orifice plates will be specified during the detailed design stage for all street and rear yard catch basins to limit the inflow to the minor system to the target 210.6 L/s release rate. As the proposed roadways are anticipated to capture in excess of the target release rate on an area basis due to increases in imperviousness and decrease in overall system time of concentration, development blocks will be required to be overcontrolled to meet the overall system target release rates to avoid ponding requirements during the 2-year storm event on local roadways. The proposed park block is anticipated to release to the proposed storm sewers uncontrolled.

A detailed hydrologic and hydraulic model will be completed at the detailed design stage to assess the total surface flow depth on streets during major storm events and to size ICDs to meet the target release rate. **Drawing SD-1** outlines the functional proposed storm sewer alignment and drainage divides. **Table 4** below identifies the target release rates and required storage for each development block on a per hectare basis. Major system storage is anticipated to be provided on the surface in the case of roadways. Development blocks will require storage to be assigned within surface ponding areas in parking lots (for storms above the 2-year event), in subsurface cisterns or storage pipes, in managed surface swales, rain gardens or pocket dry ponds, or on building rooftops.

Table 4. Summary of Proposed Storage and Peak Flow Requirements

Block Type	Unit 2-Year Release Rate (L/s/ha)	Unit 100-Year Release Rate (L/s/ha)	Unit 2-Year Storage Volume (m3/ha)	Unit 100-Year Storage Volume (m3/ha)
Park C=0.3	74.7	217.2	0	0
Road C=0.6	128.1	143.4	0	137.3
Res. C=0.7	54.1	149.6	57.1	149.6

5.2.1 Quality Control

On-site quality control is required to provide 80% TSS removal prior to discharging to the existing storm sewer main. An oil-grit separator (OGS, here specified as a Stormceptor Unit EF08) is proposed at the downstream end of the site storm sewer system. Runoff from roof top areas is considered clean, but were assumed as impervious when calculating the total imperviousness of the contributing catchment area to the OGS for conservatism. Design calculations for the OGS indicate that the selected model will provide greater than 80% TSS removal on an annual basis. The OGS unit will be maintained by City of Ottawa forces. The location and general arrangement of the OGS unit is indicated on **Drawing SD-1**. Detailed sizing calculations for the example unit are included in **Appendix C.3**. The Stormceptor unit has been selected as an example only for purposes of demonstration of quality control; A different oil grit separator unit can be selected if it is shown to have an equivalent reduction in total suspended solids and comparable operational characteristics.



5.3 WATER BALANCE – INFILTRATION REQUIREMENTS

All development in the area is required to provide infiltration measures to meet requirements noted in the Sawmill Creek Subwatershed Study identifying “maintaining pre-development water balance on a site-by-site basis, and ensuring maintenance of annual and seasonal water table recharge”. Opportunities to implement on-site infiltration and pollutant control measures will be explored as per the subwatershed study at the site plan stage for each development block. As the City of Ottawa does not currently have a reference regarding low-impact development controls within municipal ROWs, *Table 17* within the subwatershed study, which details best management practices (BMPs) for improving infiltration, will need to be referenced. The following BMPs are a few of those listed in the subwatershed study:

- Roof drainage to pervious areas
- Grassed swales
- Bio-retention areas
- Shallow pervious pipe systems
- Shallow infiltration ponds and basins
- Grassed swales or shallow depressions
- Inclusion of a topsoil amendment program

A subsurface investigation will be undertaken to establish native soil infiltration potential at the detailed design stage to determine the BMPs selected for the proposed development sites. Furthermore, each development block will need to be studied individually to assess its necessary infiltration measures. Given the elevated groundwater conditions within the site, it is anticipated that subsurface infiltration measures will not be achievable in meeting water balance requirements.



6.0 GEOTECHNICAL CONSIDERATIONS AND GRADING

6.1 GEOTECHNICAL INVESTIGATION

A geotechnical investigation report for the development was completed by EXP Services Inc. on May 16, 2024. Excerpts of the geotechnical investigation report are included in **Appendix D.1**.

Generally, the subsurface profile encountered at the test hole locations consists of a thin layer of topsoil or reclaimed asphalt pavement underlain by fill. The depth of the fill material was found to range between 0.3 to 3.0 meters. The fill material consisted of a mix of crushed stone, silty sand, and silty clay. Below the fill material was a layer of firm to very stiff silty clay up to a depth of 4.5 meters underlain by a loose layer of silty sand or glacial till. Weathered shale bedrock was found below the previously mentioned layers at depths between 5.8 to 6.9 meters.

Shale bedrock were encountered underlying the overburden soils at the borehole locations. Generally, the bedrock consists of a weathered shale in the upper portion of the rock core and is characterized by being fair to good quality bedrock based on the RQD values. Based on available geological mapping, the subject site is located within an area where the bedrock mainly consists of shale and limestone of the Carlsbad formation.

Groundwater elevations were measured using boreholes equipped with monitoring wells and were found to range from 1.3 to 2.7 meters.

6.1.1 Groundwater Control

It is anticipated that groundwater infiltration into the excavations should be controllable using open sumps. The contractor should be prepared to direct water away from all bearing surfaces and subgrades, regardless of the source, to prevent disturbance to the founding medium.

A temporary Ministry of the Environment, Conservation, and Parks (MECP) permit to take water (PTTW) may be required for this project if more than 400,000 L/day of ground and/or surface water is to be pumped during the construction phase. A minimum of 4 to 5 months should be allowed for completion of the PTTW application package and issuance of the permit by the MECP.

For typical ground or surface water volumes being pumped during the construction phase, between 50,000 to 400,000 L/day, it is required to register on the Environmental Activity and Sector Registry (EASR). A minimum of two to four weeks should be allotted for completion of the EASR registration and the Water Taking and Discharge Plan to be prepared by a Qualified Person as stipulated under O.Reg. 63/16. If a project qualifies for a PTTW based upon anticipated conditions, an EASR will not be allowed as a temporary dewatering measure while awaiting the MECP review of the PTTW application.



6.2 FUNCTIONAL GRADING PLAN

Preliminary grading for the proposed site has been provided as shown on **Drawing GP-1**. Grading design has been based on the existing topography and the requirement to route overland flows from the proposed development to Heatherington Road. Given the current topography, site grading will be designed to match the existing boundaries of the site as well as the Boys & Girls Club of Ottawa building. Major system flows from the development will be directed to Heatherington Road. The high point at Walkley Road will direct flows south along Heatherington Road.

Due to the elevated groundwater conditions, traditional single family homes, townhomes, back-to-back unit underside of foundations (USFs) will be required to be elevated to avoid continuous groundwater inflow to the receiving storm sewer systems and meet requirements of Ottawa's Sewer Design Guidelines (OSDG). This requirement could be mitigated in part by anticipated long-term groundwater reductions of up to 1m as noted in the geotechnical report. Building footing elevations will be assessed at time of detailed design to ensure proper interaction with anticipated groundwater levels.



Approvals

7.0 APPROVALS

An Environmental Compliance Approval (ECA) will be required from the Ontario Ministry of the Environment, Conservation and Parks (MECP) for the proposed works in support of storm and sanitary sewers and their appurtenances provided for residents of a municipality.

The Rideau Valley Conservation Authority will be circulated with this functional design submission.

An MECP Permit to Take Water (PTTW) or registration on the Environmental Activity and Sector Registry may be required as noted in Section 6.0 above.

No other approval requirements from other regulatory agencies are anticipated.

8.0 UTILITIES

Utility infrastructure exists within the Heatherington Road ROW at the east property boundary of the proposed site. Overhead telecom poles are located along the north boundary of the site area. Coordination with the appropriate governing bodies will be required to relocate or remove the existing telecom poles, and will be explored in the detailed design phase. It is anticipated that existing infrastructure will be sufficient to provide a means of distribution for the proposed site. Exact size, location and routing of utilities will be finalized after design circulation.



Erosion Control

9.0 EROSION CONTROL

In order to protect downstream water quality and prevent sediment build up in catch basins and storm sewers, erosion and sediment control measures must be implemented during construction. The following recommendations will be included in the contract documents and communicated to the Contractor.

1. Implement best management practices to provide appropriate protection of the existing and proposed drainage system and the receiving water course(s).
2. Limit the extent of the exposed soils at any given time.
3. Re-vegetate exposed areas as soon as possible.
4. Minimize the area to be cleared and grubbed.
5. Protect exposed slopes with geotextiles, geogrid, or synthetic mulches.
6. Provide sediment traps and basins during dewatering works.
7. Install sediment traps (such as SiltSack® by Terrafix) between catch basins and frames.
8. Schedule the construction works at times which avoid flooding due to seasonal rains.

The Contractor will also be required to complete inspections and guarantee the proper performance of their erosion and sediment control measures at least after every rainfall. The inspections are to include:

- Verification that water is not flowing under silt barriers.
- Cleaning and changing the sediment traps placed on catch basins.

Refer to **Drawing EC-1** for the proposed location of erosion control measures.



Conclusions and Recommendations

10.0 CONCLUSIONS AND RECOMMENDATIONS

10.1 POTABLE WATER SERVICING

The proposed watermain design will achieve the level of service required by the City. The following conclusions related to the potable water servicing for the subject site were made:

- The proposed development will be serviced by 200 mm diameter watermains that will provide required looping to the subdivision development.
- A proposed 200 mm diameter watermain extension from Walkley Road to the stub on Heatherington road will provide the necessary flows to the site and can be upsized to a 300 mm diameter watermain if required during detailed design analysis to meet anticipated required fire flows.
- The boundary conditions provided by the City of Ottawa demonstrate that the existing municipal watermain can provide sufficient domestic flow to meet the requirements of the development. The pressures during average day, peak hour, and max day plus fire flow fall within the targets outlined in City of Ottawa Water Distribution Guidelines.
- The boundary conditions provided by the City of Ottawa demonstrate that the existing municipal watermain can provide sufficient fire flow to meet the requirements of the development while maintaining minimum residual pressures.

10.2 WASTEWATER SERVICING

The existing municipal sanitary sewers have adequate capacity to convey the wastewater design flows for the site. The following conclusions related to the wastewater servicing for the subject site were made:

- The development is proposed to be serviced by a network of 200 mm diameter gravity sanitary sewers and will have two connections to the existing 375 mm diameter local sanitary sewer on Heatherington Road.
- The total peak wastewater design flow from the site is 4.8 L/s and has not been identified as a concern for downstream residual capacity in the current sanitary infrastructure along Heatherington Road.

10.3 STORMWATER MANAGEMENT AND SERVICING

The proposed stormwater management plan complies with the requirements outlined in the background documents, the City of Ottawa Sewer Design Guidelines and the Ontario Ministry of the Environment,



Conclusions and Recommendations

Conservation and Parks (MECP) Stormwater Management Planning and Design Manual. The following conclusions associated with the stormwater management for the subject site were made:

- The proposed development is within the Sawmill Creek Subwatershed area.
- A proposed oil grit separator unit will provide quality control (80% TSS removal) for the site.
- Restrict inflows to the storm sewer from the proposed development per Sawmill Creek Subwatershed Study recommendations.
- Minor system peak flows from the site designed to convey the 2-year storm event under free-flow conditions and be directed to the existing 675 mm diameter sewer.
- Major system peak flows from the site will be directed to Heatherington Road which allocates major system flows southwards.
- Explore infiltration best management practices at the site plan level to meet water balance criteria as identified in the Sawmill Creek study.

10.4 GRADING, EROSION AND SEDIMENT CONTROL

Grading design for the development has been provided to route overland flows from the development to Heatherington Road. Grades will be matched to the existing boundaries of the site as well as to the existing Boys & Girls Club of Ottawa property. Erosion and sediment control measures, outlined in this report and included in the drawing set, will be implemented during construction to reduce the impact on existing services.

10.5 APPROVALS/PERMITS

An MECP Environmental Compliance Approval (ECA) is required for the installation of the proposed storm and sanitary sewers within the site.

A Permit to Take Water or registration on the EASR may be required for dewatering works during sewer/watermain installation, pending confirmation by the geotechnical consultant in the detailed design stage.

The Rideau Valley Conservation Authority will be circulated with the application by the City of Ottawa.

No other approval requirements from other regulatory agencies are anticipated.



Conclusions and Recommendations

10.6 UTILITIES

Utility infrastructure for Bell, Rogers, Hydro Ottawa, and Enbridge exists adjacent to the subject site. Existing overhead telecom poles exist along the north boundary of the site area. The exact size, location, and routing of utilities will be coordinated and finalized at the detailed design stage.



APPENDICES

Appendix A – POTABLE WATER SERVICING

A.1 BOUNDARY CONDITIONS



From: [Cassidy, Tyler](#)
To: [Mott, Peter](#); [Gillis, Sheridan](#)
Cc: [Dickinson, Mary](#)
Subject: 1770 Heatherington - Available Fire Flow for Watermain Extension Scenarios
Date: Wednesday, June 14, 2023 1:32:46 PM

Hi Peter & Sheridan,

Following up to the meeting we had the other week, I've received some additional information from our water resources group regarding the 1770 Heatherington project I'd like to share. I had our team investigate what the maximum available fire flow is under two (2) water servicing scenarios. We updated the City's hydraulic model to include an extension of the 203mm dia. watermain on Heatherington to the 406mm dia. on Walkley Road as the first scenario. As a second scenario, we upsized the ~60m extension to a 305mm watermain. The results are as follows:

- Scenario 1 – 203mm dia. watermain extension from Heatherington to Walkley Road: Available Fire Flow = 176 L/s.
- Scenario 2 – 305mm dia. watermain extension/upsized from Heatherington to Walkley Road: Available Fire Flow = 200 L/s.

I hope you find the information above useful, please let me know if you have any questions in the interim.

Thank you,

Tyler Cassidy, P.Eng

Infrastructure Project Manager,
Planning, Real Estate and Economic Development Department / Direction générale de la planification,
des biens immobiliers et du développement économique - South Branch
City of Ottawa | Ville d'Ottawa
110 Laurier Avenue West Ottawa, ON | 110, avenue. Laurier Ouest. Ottawa (Ontario) K1P 1J1
613.580.2424 ext./poste 12977, Tyler.Cassidy@ottawa.ca

This e-mail originates from the City of Ottawa e-mail system. Any distribution, use or copying of this e-mail or the information it contains by other than the intended recipient(s) is unauthorized. Thank you.

Le présent courriel a été expédié par le système de courriels de la Ville d'Ottawa. Toute distribution, utilisation ou reproduction du courriel ou des renseignements qui s'y trouvent par une personne autre que son destinataire prévu est interdite. Je vous remercie de votre collaboration.

Caution: This email originated from outside of Stantec. Please take extra precaution.

Attention: Ce courriel provient de l'extérieur de Stantec. Veuillez prendre des

précautions supplémentaires.

Atención: Este correo electrónico proviene de fuera de Stantec. Por favor, tome precauciones adicionales.

From: [Cassidy, Tyler](#)
To: [Gillis, Sheridan](#)
Cc: [Mott, Peter](#); [Dickinson, Mary](#); [Seigny, John](#)
Subject: RE: Boundary Conditions Request - 1770 Heatherington Road (Ward 10)
Date: Wednesday, May 24, 2023 10:55:42 AM
Attachments: [image012.png](#)
[image013.png](#)
[image014.jpg](#)
[image001.jpg](#)
[image002.jpg](#)
[image005.jpg](#)
[image006.jpg](#)

Hi Sheridan,

Thank you for your patience as I took some time to discuss internally with several other City departments/groups. Our Water Resources group did confirm that with the extension of the 200mm watermain to Walkley Road, that a required fire flow (RFF) of 10,000 L/min could be supported. I did not obtain the maximum available fire flow of this scenario, but our engineer did say that 15,000 L/min for the multi-unit residential was still too great of a demand under the proposed configuration. If you choose to further investigate this configuration, I can obtain more detailed information on the maximum available flow @ 20 psi.

I also liaised with our Infrastructure Renewal group to see if there was any funding or planned capital projects to renew/upgrade the watermain on Heatherington. Unfortunately, the watermain is not slated for renewal at this time and there is no funding available from the City to engage in any cost sharing for this upgrade should you choose to pursue it. The cost of the extension would be the onus of the applicant. I do acknowledge this is an Ottawa Community Housing project and that affordability is a key component of this project. Perhaps Stantec could investigate the economics of either implementing fire measures (firewalls and sprinklers) versus extending the main to Walkley Road to meet fire flow requirements under the current site plan – I'll leave the ball in your court.

If you wish to further discuss I can organize a meeting at your convenience. Just let me know and provide a few availabilities and we can move forward from there.

Thank you,

Tyler Cassidy, P.Eng

Infrastructure Project Manager,
Planning, Real Estate and Economic Development Department / Direction générale de la planification, des biens immobiliers et du développement économique - South Branch
City of Ottawa | Ville d'Ottawa
110 Laurier Avenue West Ottawa, ON | 110, avenue. Laurier Ouest. Ottawa (Ontario) K1P 1J1
613.580.2424 ext./poste 12977, Tyler.Cassidy@ottawa.ca

From: Gillis, Sheridan <Sheridan.Gillis@stantec.com>
Sent: May 17, 2023 9:45 AM
To: Cassidy, Tyler <tyler.cassidy@ottawa.ca>
Cc: Mott, Peter <Peter.Mott@stantec.com>; Dickinson, Mary <mary.dickinson@ottawa.ca>
Subject: RE: Boundary Conditions Request - 1770 Heatherington Road (Ward 10)

CAUTION: This email originated from an External Sender. Please do not click links or open attachments unless you recognize the source.

ATTENTION : Ce courriel provient d'un expéditeur externe. Ne cliquez sur aucun lien et n'ouvrez pas de pièce jointe, excepté si vous connaissez l'expéditeur.

Hi Tyler,

Thanks for looking at this, we think a meeting is a good idea, please let us know if something can be scheduled after discussing internally. We obviously don't have the City water model, but we assume the entire neighbourhood might have insufficient fire supply. If this is the case, we assume the City would seek ways to improve flows in the area. Some ideas which could be modeled are extending that 200mm main to Walkley Road (not sure why it's currently stubbed with awkward configuration to 150mm) and providing a 2nd feed through the community housing block.

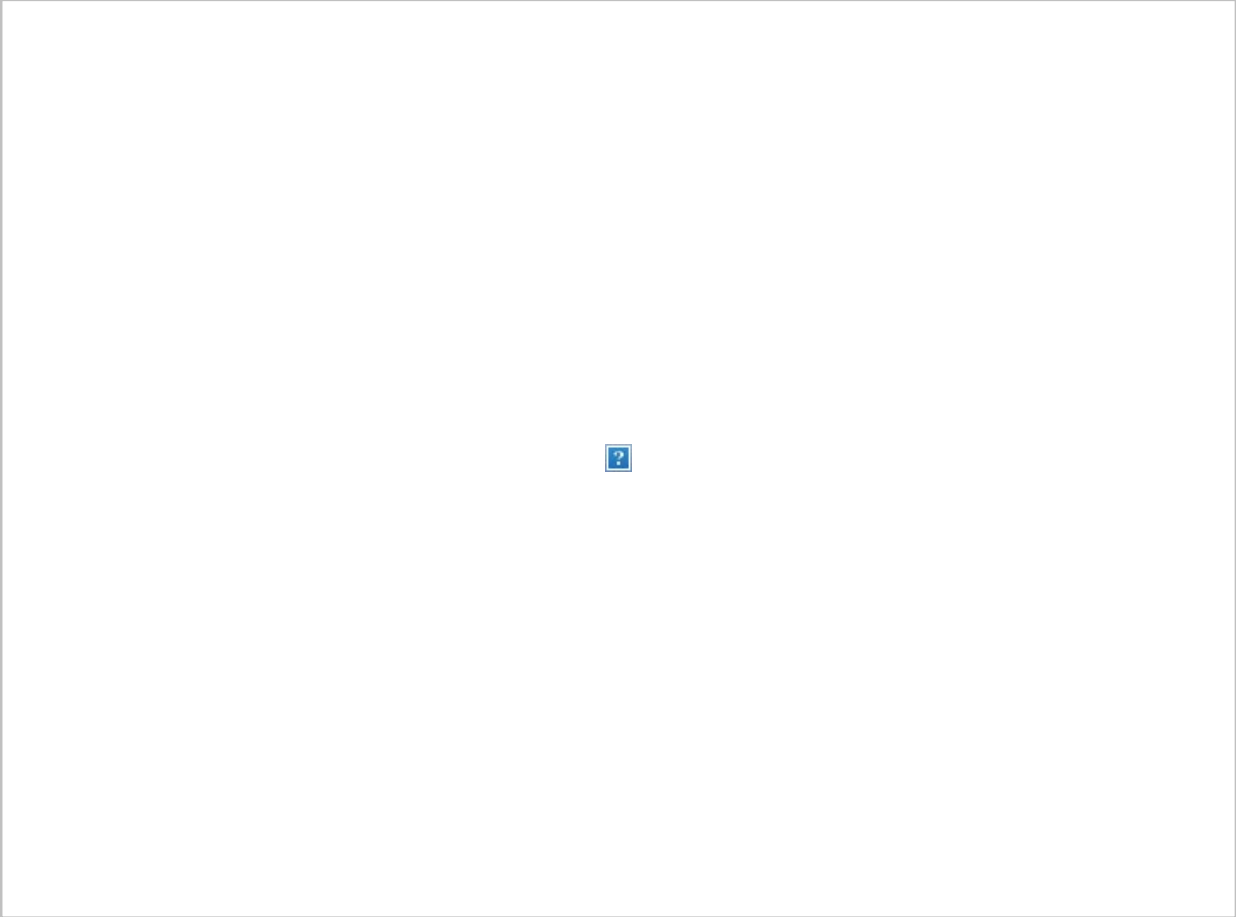

Once you have a bit more information let us know a time that works for you to meet. I've copied the City file lead for this project Mary Dickenson on this email, please include Mary on any future invite.
Thanks,

Sheridan Gillis

Project Manager, Urban Land Engineering
Stantec
400 - 1331 Clyde Avenue Ottawa ON K2C 3G4
Phone: (613) 799-1363
sheridan.gillis@stantec.com



Design with community in mind

From: Cassidy, Tyler <tyler.cassidy@ottawa.ca>
Sent: Tuesday, May 16, 2023 11:19 AM
To: Mott, Peter <Peter.Mott@stantec.com>
Cc: Gillis, Sheridan <Sheridan.Gillis@stantec.com>
Subject: RE: Boundary Conditions Request - 1770 Heatherington Road (Ward 10)

Hi Peter,

Thank you for reaching out and bringing some of these issues to my attention. I am not aware of any planned upgrades to the water distribution system around this site. I do acknowledge that this is an affordable housing project. What I'd like to do discuss internally with some of my colleagues in the water resources/infrastructure services groups and see if there is anything we can do to help. If you can give me a few days to coordinate within the City, then I can follow up with you and

schedule a meeting if it is warranted. I will be in touch towards the end of this week/early next week.

Thank you,

Tyler Cassidy, P.Eng

Infrastructure Project Manager,
Planning, Real Estate and Economic Development Department / Direction générale de la planification, des biens immobiliers et du développement économique - South Branch
City of Ottawa | Ville d'Ottawa
110 Laurier Avenue West Ottawa, ON | 110, avenue. Laurier Ouest. Ottawa (Ontario) K1P 1J1
613.580.2424 ext./poste 12977, Tyler.Cassidy@ottawa.ca

From: Mott, Peter <Peter.Mott@stantec.com>
Sent: May 16, 2023 9:31 AM
To: Cassidy, Tyler <tyler.cassidy@ottawa.ca>
Cc: Gillis, Sheridan <Sheridan.Gillis@stantec.com>
Subject: RE: Boundary Conditions Request - 1770 Heatherington Road (Ward 10)

CAUTION: This email originated from an External Sender. Please do not click links or open attachments unless you recognize the source.

ATTENTION : Ce courriel provient d'un expéditeur externe. Ne cliquez sur aucun lien et n'ouvrez pas de pièce jointe, excepté si vous connaissez l'expéditeur.

Hi Tyler – Thank you for providing the boundary conditions. Based on the BC's provided, it looks like it will be fairly challenging to meet a fire flow requirement of 127 L/s with the building layouts that we currently have in the Draft Plan. I was wondering if you are aware of any future upgrades to this area as the pressures are seemingly low considering the proposed development is in close proximity to the 400 mm diameter watermain within Walkley Road. I will have to put some FUS calculation sheets together to determine what fire suppression measures will be required which I'm assuming will be quite substantial, but was wondering if you have any insight on measures that can be taken to achieve minimum pressure requirements?

For example, even with the required setbacks and fire suppression measures according to ISDTB-2014-02, the 6-unit townhouse rows would still be unable to achieve the 10,000 L/min capped fire flow. The addition of two fire walls per 6-unit townhouse row could be an option but would result in significant costs for the community housing project. If you have any feedback, it would be much appreciated as we plan to sit down with the City this week to discuss and work towards addressing this aspect of the servicing. Thanks for your time and appreciate any insight you can provide.

Best,

Peter Mott EIT

Engineering Intern, Community Development

Mobile: +1 (613) 897-0445

Teams: +1 (613) 724-4370

Peter.Mott@stantec.com

Stantec

300 - 1331 Clyde Avenue

Ottawa ON K2C 3G4



The content of this email is the confidential property of Stantec and should not be copied, modified, retransmitted, or used for any purpose except with Stantec's written authorization. If you are not the intended recipient, please delete all copies and notify us immediately.

From: Cassidy, Tyler <tyler.cassidy@ottawa.ca>
Sent: Monday, May 8, 2023 11:05 AM
To: Mott, Peter <Peter.Mott@stantec.com>
Cc: Gillis, Sheridan <Sheridan.Gillis@stantec.com>
Subject: RE: Boundary Conditions Request - 1770 Heatherington Road (Ward 10)

Hi Peter,

Thank you for following up. The boundary conditions just came in this morning, please see below:

The following are boundary conditions, HGL, for hydraulic analysis at 1770 Heatherington Road (zone 2W2C) assumed to be a looped connection to the 203 mm watermain on Heatherington Road. (see attached PDF for location).

Minimum HGL: 123.5 m

Maximum HGL: 130.1 m

Available Fire Flow At 20 psi: 127 L/s, assuming ground elevations of 86.9 m (Connection 1) and 86.7 m (Connection 2)

These are for current conditions and are based on computer model simulation.

Disclaimer: The boundary condition information is based on current operation of the city water distribution system. The computer model simulation is based on the best information available at the time. The operation of the water distribution system can change on a regular basis, resulting in a variation in boundary conditions. The physical properties of watermains deteriorate over time, as such must be assumed in the absence of actual field test data. The variation in physical watermain properties can therefore alter the results of the computer model simulation.

Please take note of the relatively low availability of flow during the fire flow demand scenario.

Thank you,

Tyler Cassidy, P.Eng

Infrastructure Project Manager,

Planning, Real Estate and Economic Development Department / Direction générale de la planification, des biens immobiliers et du développement économique - South Branch

City of Ottawa | Ville d'Ottawa

110 Laurier Avenue West Ottawa, ON | 110, avenue. Laurier Ouest. Ottawa (Ontario) K1P 1J1

613.580.2424 ext./poste 12977, Tyler.Cassidy@ottawa.ca

From: Mott, Peter <Peter.Mott@stantec.com>

Sent: May 04, 2023 10:26 AM

To: Cassidy, Tyler <tyler.cassidy@ottawa.ca>

Cc: Gillis, Sheridan <Sheridan.Gillis@stantec.com>

Subject: RE: Boundary Conditions Request - 1770 Heatherington Road (Ward 10)

CAUTION: This email originated from an External Sender. Please do not click links or open attachments unless you recognize the source.

ATTENTION : Ce courriel provient d'un expéditeur externe. Ne cliquez sur aucun lien et n'ouvrez pas de pièce jointe, excepté si vous connaissez l'expéditeur.

Hi Tyler – I just wanted to follow up on the below boundary condition request. As previously mentioned, the request is for a City of Ottawa initiated affordable housing project which is somewhat time sensitive in nature. As tomorrow marks 10 business days since the initial request, I was hoping you could help us out and follow up with the modelling group before the end of the week to help us keep things moving in the right direction. Thanks for your consideration.

Best,

Peter Mott EIT

Engineering Intern, Community Development

Mobile: +1 (613) 897-0445

Teams: +1 (613) 724-4370

Peter.Mott@stantec.com

Stantec

300 - 1331 Clyde Avenue

Ottawa ON K2C 3G4



From: Cassidy, Tyler <tyler.cassidy@ottawa.ca>
Sent: Friday, April 21, 2023 1:48 PM
To: Mott, Peter <Peter.Mott@stantec.com>
Cc: Gillis, Sheridan <Sheridan.Gillis@stantec.com>
Subject: RE: Boundary Conditions Request - 1770 Heatherington Road (Ward 10)

Hi Peter,

Thank you for your explanation. I've gone ahead and submitted your two (2) original demand scenarios of 10,000 L/min & 15,000 L/min + basic day demands to our water resources group. Typically, we try to maintain required fire flows for residential developments to under 15,000 L/s, so I omitted the 17,000 L/s from the request. In the event your required fire flows are this high during detailed design, we can revisit the boundary conditions to see what's feasible for the area.

Please allow for up to 10 business days for results to be provided. If you have any questions in the interim please feel free to reach out.

Thank you,

Tyler Cassidy, P.Eng

Infrastructure Project Manager,
Planning, Real Estate and Economic Development Department / Direction générale de la planification, des biens immobiliers et du développement économique - South Branch
City of Ottawa | Ville d'Ottawa
110 Laurier Avenue West Ottawa, ON | 110, avenue. Laurier Ouest. Ottawa (Ontario) K1P 1J1
613.580.2424 ext./poste 12977, Tyler.Cassidy@ottawa.ca

From: Mott, Peter <Peter.Mott@stantec.com>
Sent: April 21, 2023 12:16 PM
To: Cassidy, Tyler <tyler.cassidy@ottawa.ca>
Cc: Gillis, Sheridan <Sheridan.Gillis@stantec.com>
Subject: RE: Boundary Conditions Request - 1770 Heatherington Road (Ward 10)

CAUTION: This email originated from an External Sender. Please do not click links or open attachments unless you recognize the source.

ATTENTION : Ce courriel provient d'un expéditeur externe. Ne cliquez sur aucun lien et n'ouvrez pas de pièce jointe, excepté si vous connaissez l'expéditeur.

Hi Tyler – With regards to the exposure distances for Building 1 and Building 14 (multi-unit buildings), you are correct that there are slight discrepancies between the FUS calculations and what is provided within the Site Plan. Given the early stages of planning for this development, our intention is to receive lower (10,000 L/min) and upper limit (15,000 L/min) demand scenarios for the boundary conditions to ultimately see what we are dealing with in terms of pressures for the area. We are cognizant that the fire flow requirements will largely dictate the building layouts within site and that the 203 mm diameter watermain fronting the site is unlikely to provide fire flows in excess of 15,000 L/min. We also understand that on-site measures (sprinklered building, firewalls, etc.) may be required, which will be addressed when the available pressures are better understood.

In terms of the building description for the 3-storey townhouse units, I completely disregarded any references to the bedroom counts and simply used the number of units and used the ODG to determine a population count for the various demand scenarios. That site plan will be updated and refined accordingly as we move forward through this application.

With that said, I've provided an update to the FUS calculations for building 1 and 14 based on the changes to the exposure distances you suggested, which yields a FFR of 17,000 L/min... Not a flow that this development is likely to be achieved without on-site measures implemented. As this a Ottawa Community Housing Project, which is time sensitive in nature, I'm hopeful that you understand our situation and we can work together to get the information we need which will help inform the design. Please give me a call if you wish to discuss or have any further questions.

If you would like to send the boundary conditions for the range of MD+FF scenarios (10,000 L/min, 15,000 L/min and 17,000 L/min) please feel free to do so!

Best regards,

Peter Mott EIT

Engineering Intern, Community Development

Mobile: +1 (613) 897-0445

Teams: +1 (613) 724-4370

Peter.Mott@stantec.com

Stantec

300 - 1331 Clyde Avenue

Ottawa ON K2C 3G4



The content of this email is the confidential property of Stantec and should not be copied, modified, retransmitted, or used for any purpose except with Stantec's written authorization. If you are not the intended recipient, please delete all copies and notify us immediately.

From: Cassidy, Tyler <tyler.cassidy@ottawa.ca>
Sent: Friday, April 21, 2023 11:06 AM
To: Mott, Peter <Peter.Mott@stantec.com>
Cc: Gillis, Sheridan <Sheridan.Gillis@stantec.com>
Subject: RE: Boundary Conditions Request - 1770 Heatherington Road (Ward 10)

Hi Peter,

During my review of the FUS calculations I've noticed that the exposure adjustment charges for both of the 15,000 L/s multi-unit buildings appear to be incorrect per the site plan provided (Rev. 2 dated 2022-09-12). Note that Building 1 is separated by ~15m to the building due north, and building 14 is separated by ~12m to the building due south. Also note that it appears that Firewalls will need to be incorporated into buildings 2, 3 & 4 as, per the scaled site plan, there is less than 3m separation between buildings. If you could kindly review and confirm the exposure charges for the FUS calculations provided that would be greatly appreciated.

Lastly, could you provide some sort of description for the 3-storey townhouse units? I'm having a hard time comprehending how "6 three bedroom + den units" equates to a total of 30 bedrooms per building.

Please review, revise, and confirm as necessary and resubmit at your earliest convenience.

Thank you,

Tyler Cassidy, P.Eng

Infrastructure Project Manager,

Planning, Real Estate and Economic Development Department / Direction générale de la planification, des biens immobiliers et du développement économique - South Branch

City of Ottawa | Ville d'Ottawa

110 Laurier Avenue West Ottawa, ON | 110, avenue. Laurier Ouest. Ottawa (Ontario) K1P 1J1

613.580.2424 ext./poste 12977, Tyler.Cassidy@ottawa.ca

From: Mott, Peter <Peter.Mott@stantec.com>
Sent: April 20, 2023 3:46 PM
To: Cassidy, Tyler <tyler.cassidy@ottawa.ca>
Cc: Gillis, Sheridan <Sheridan.Gillis@stantec.com>
Subject: RE: Boundary Conditions Request - 1770 Heatherington Road (Ward 10)

CAUTION: This email originated from an External Sender. Please do not click links or open attachments unless you recognize the source.

ATTENTION : Ce courriel provient d'un expéditeur externe. Ne cliquez sur aucun lien et n'ouvrez pas de pièce jointe, excepté si vous connaissez l'expéditeur.

Hi Tyler – Please find the FUS calculations attached. The 4-storey apartment buildings at the North and South of the site, fronting Heatherington Road, were determined to have a fire flow requirement of 15,000 L/min (250 L/s) and the Townhouses are expected to have a capped fire flow requirement of 10,000 L/min per ISDTB-2014-02.

Please let me know if you have any questions or further comments with regards to the provided BC request.

Best,

Peter Mott EIT
Engineering Intern, Community Development
Mobile: +1 (613) 897-0445
Teams: +1 (613) 724-4370
Peter.Mott@stantec.com
Stantec
300 - 1331 Clyde Avenue
Ottawa ON K2C 3G4



The content of this email is the confidential property of Stantec and should not be copied, modified, retransmitted, or used for any purpose except with Stantec's written authorization. If you are not the intended recipient, please delete all copies and notify us immediately.

From: Cassidy, Tyler <tyler.cassidy@ottawa.ca>
Sent: Thursday, April 20, 2023 10:51 AM
To: Mott, Peter <Peter.Mott@stantec.com>
Cc: Gillis, Sheridan <Sheridan.Gillis@stantec.com>
Subject: RE: Boundary Conditions Request - 1770 Heatherington Road (Ward 10)

Hi Peter,

I'll be taking over this file as Eric has moved from Development Review to Infrastructure Services.

If you could please provide me with your calculations for the FUS method of Required Fire Flow (RFF) I can then proceed with submitting the request to our water resources group. If you could provide the calculations for both of the demand situations you outlined below, that would be greatly appreciated.

Thank you,

Tyler Cassidy, P.Eng
Infrastructure Project Manager,
Planning, Real Estate and Economic Development Department / Direction générale de la planification, des biens immobiliers et du développement économique - South Branch
City of Ottawa | Ville d'Ottawa
110 Laurier Avenue West Ottawa, ON | 110, avenue. Laurier Ouest. Ottawa (Ontario) K1P 1J1
613.580.2424 ext./poste 12977, Tyler.Cassidy@ottawa.ca

From: Mott, Peter <Peter.Mott@stantec.com>
Sent: April 19, 2023 3:31 PM
To: Harrold, Eric <eric.harrold@ottawa.ca>
Cc: Gillis, Sheridan <Sheridan.Gillis@stantec.com>
Subject: Boundary Conditions Request - 1770 Heatherington Road (Ward 10)

CAUTION: This email originated from an External Sender. Please do not click links or open attachments unless you recognize the source.

ATTENTION : Ce courriel provient d'un expéditeur externe. Ne cliquez sur aucun lien et n'ouvrez pas de pièce jointe, excepté si vous connaissez l'expéditeur.

Hello Eric,

I would like to request the hydraulic boundary conditions for the proposed development located at 1770 Heatherington Road. Please find attached the conceptual site plan, the key map showing the location of the proposed development, and the domestic water demand calculations for the proposed development.

A summary of the proposed site is provided below:

We anticipate two connections to the existing watermain infrastructure to service the site. The following connections are expected for servicing:

➤ Two connection(s) to the existing 203 mm (CI) watermain on Heatherington Road. (Assuming that both connections will have the same BC)

*Existing fire hydrant along Heatherington Road fronting the adjacent property to the North.

For the purpose of the boundary conditions request, may you please provide us with the boundary conditions for the following servicing options:

- i. Two watermain connections to the existing 203 mm (CI) watermain on Heatherington Road; assuming a fire flow requirement of **10,000 L/min** for the site in addition to the domestic water demands provided below.
 - ii. Two watermain connections to the existing 203 mm (CI) watermain on Heatherington Road; assuming a fire flow requirement of **15,000 L/min** for the site in addition to the domestic water demands provided below.
- The intended land use is primarily residential with a building intended for community use per the summary provided in the Domestic Demands spreadsheet. (See attached Site Plan with project stats)
 - Provided fire flow demand range is between 10,000 L/min (167 L/s) and 15,000 L/min (250 L/s)
 - Domestic water demands for the entire development:
 - **Average day: 67.0 L/min (1.1 L/s)**
 - **Maximum day: 157.9 L/min (2.6L/s)**
 - **Peak hour: 341.8L/min (5.7 L/s)**

Thank you for your time and please contact me at your earliest convenience if any additional information or clarification is required.

Best regards,

Peter Mott EIT

Engineering Intern, Community Development

Mobile: +1 (613) 897-0445

Teams: +1 (613) 724-4370

Peter.Mott@stantec.com

Stantec

300 - 1331 Clyde Avenue

Ottawa ON K2C 3G4



This e-mail originates from the City of Ottawa e-mail system. Any distribution, use or copying of this e-mail or the information it contains by other than the intended recipient(s) is unauthorized. Thank you.

Le présent courriel a été expédié par le système de courriels de la Ville d'Ottawa. Toute distribution, utilisation ou reproduction du courriel ou des renseignements qui s'y trouvent par une personne autre que son destinataire prévu est interdite. Je vous remercie de votre collaboration.

Caution: This email originated from outside of Stantec. Please take extra precaution.

Attention: Ce courriel provient de l'extérieur de Stantec. Veuillez prendre des précautions supplémentaires.

Atención: Este correo electrónico proviene de fuera de Stantec. Por favor, tome precauciones adicionales.

This e-mail originates from the City of Ottawa e-mail system. Any distribution, use or copying of this e-mail or the information it contains by other than the intended recipient(s) is unauthorized. Thank you.

Le présent courriel a été expédié par le système de courriels de la Ville d'Ottawa. Toute distribution, utilisation ou reproduction du courriel ou des renseignements qui s'y trouvent par une personne autre que son destinataire prévu est interdite. Je vous remercie de votre collaboration.

Caution: This email originated from outside of Stantec. Please take extra precaution.

Attention: Ce courriel provient de l'extérieur de Stantec. Veuillez prendre des précautions supplémentaires.

Atención: Este correo electrónico proviene de fuera de Stantec. Por favor, tome precauciones adicionales.

This e-mail originates from the City of Ottawa e-mail system. Any distribution, use or copying of this e-mail or the information it contains by other than the intended recipient(s) is unauthorized. Thank you.

Le présent courriel a été expédié par le système de courriels de la Ville d'Ottawa. Toute distribution, utilisation ou reproduction du courriel ou des renseignements qui s'y trouvent par une personne autre que son destinataire prévu est interdite. Je vous remercie de votre collaboration.

Caution: This email originated from outside of Stantec. Please take extra precaution.

Attention: Ce courriel provient de l'extérieur de Stantec. Veuillez prendre des précautions supplémentaires.

Atención: Este correo electrónico proviene de fuera de Stantec. Por favor, tome precauciones adicionales.

This e-mail originates from the City of Ottawa e-mail system. Any distribution, use or copying of this e-mail or the information it contains by other than the intended recipient(s) is unauthorized. Thank you.

Le présent courriel a été expédié par le système de courriels de la Ville d'Ottawa. Toute distribution, utilisation ou reproduction du courriel ou des renseignements qui s'y trouvent par une personne autre que son destinataire prévu est interdite. Je vous remercie de votre collaboration.

Caution: This email originated from outside of Stantec. Please take extra precaution.

Attention: Ce courriel provient de l'extérieur de Stantec. Veuillez prendre des précautions supplémentaires.

Atención: Este correo electrónico proviene de fuera de Stantec. Por favor, tome precauciones adicionales.

This e-mail originates from the City of Ottawa e-mail system. Any distribution, use or copying of this e-mail or the information it contains by other than the intended recipient(s) is unauthorized. Thank you.

Le présent courriel a été expédié par le système de courriels de la Ville d'Ottawa. Toute distribution, utilisation ou reproduction du courriel ou des renseignements qui s'y trouvent par une personne autre que son destinataire prévu est interdite. Je vous remercie de votre collaboration.

Caution: This email originated from outside of Stantec. Please take extra precaution.

Attention: Ce courriel provient de l'extérieur de Stantec. Veuillez prendre des précautions supplémentaires.

Atención: Este correo electrónico proviene de fuera de Stantec. Por favor, tome precauciones adicionales.

This e-mail originates from the City of Ottawa e-mail system. Any distribution, use or copying of this e-mail or the information it contains by other than the intended recipient(s) is unauthorized. Thank you.

Le présent courriel a été expédié par le système de courriels de la Ville d'Ottawa. Toute distribution, utilisation ou reproduction du courriel ou des renseignements qui s'y trouvent par une personne autre que son destinataire prévu est interdite. Je vous remercie de votre collaboration.

Caution: This email originated from outside of Stantec. Please take extra precaution.

Attention: Ce courriel provient de l'extérieur de Stantec. Veuillez prendre des précautions supplémentaires.

Atención: Este correo electrónico proviene de fuera de Stantec. Por favor, tome precauciones adicionales.

A.2 DOMESTIC WATER DEMAND CALCULATIONS



1770 Heatherington Road Development - Domestic Water Demand Estimates

Based on conceptual development plan by CSV Architects dated 2022-09-12

Ottawa Design Guidelines - Water Distribution

Unit Type	Population	Unit
1 Bedroom Apt.	1.4	ppu
2 Bedroom Apt.	2.1	ppu
Studio Apt.	1.4	ppu
Semi-detached	3.4	ppu
Stacked Townhouse	2.7	ppu
Townhouse (Row)	2.7	ppu

Development Block/Area ID	Commercial/Institutional Area (sq.m)	Number of Residential Units	Population	Daily Demand Rate (L/cap/day or L/ha/d)	Avg. Day Demand ^{1,2}		Max. Day Demand ^{1,2}		Peak Hour Demand ^{1,2}	
					(L/min)	(L/s)	(L/min)	(L/s)	(L/min)	(L/s)
Heartherington Development										
One bedroom Apartments	-	48	67	280	13.1	0.22	32.7	0.54	71.9	1.20
Two bedroom Apartment	-	28	59	280	11.5	0.19	28.7	0.48	63.1	1.05
Studio Apartment	-	14	20	280	3.9	0.06	9.7	0.16	21.4	0.36
Semi-Detached Dwelling	-	6	20	280	4.0	0.07	9.9	0.17	21.8	0.36
Stacked Townhouse	-	32	86	280	16.8	0.28	42.0	0.70	92.4	1.54
Townhouse (Row)	-	30	81	280	15.8	0.26	39.4	0.66	86.6	1.44
Existing B&G Club Ottawa Clubhouse	1,650	-	-	28000	3.2	0.05	4.8	0.08	8.7	0.14
Proposed Park	3,237	-	-	28000	6.3	0.10	9.4	0.16	17.0	0.28
Total Site :	4887	158	334	-	74.4	1.2	176.6	2.9	382.9	6.4

- 1 Water demand criteria used to estimate peak demand rates for residential areas at demand rate of 280L/c/d are as follows:
 maximum daily demand rate = 2.5 x average day demand rate
 peak hour demand rate = 2.2 x maximum day demand rate
- 2 Water demand criteria used to estimate peak demand rates for commercial/institutional/amenity/lobby areas at demand rate of 28,000L/ha/d are as follows:
 maximum daily demand rate = 1.5 x average day demand rate
 peak hour demand rate = 1.8 x maximum day demand rate
- 3 Population density for all residential units based on a population densities provided in Table 4.1 - Per Unit Populations of the City of Ottawa Water Distribution Design Guidelines (July 2010).

Appendix B – WASTEWATER SERVICING CALCULATIONS

B.1 SANITARY SEWER DESIGN SHEET



Appendix C – STORMWATER MANAGEMENT

C.1 STORM SEWER DESIGN SHEET



C.2 RUNOFF COEFFICIENT CALCULATIONS



Federal Aviation Administration (FAA) (1970) Pre-Development Time of Concentration Calculation

Project: Heatherington Subdivision

Stantec Project Number: 160401774

<p>Federal Aviation Administration (1970)</p>	$t_c = 1.8(1.1 - C)L^{0.50}/S^{0.333} \text{ [min]}$ <p>C = rational method runoff coefficient</p> <p>L = length of overland flow, ft</p> <p>S = surface slope, ft/ft</p>	<p>Developed from air field drainage data assembled by the US Corps of Engineers; method is intended for use on airfield drainage problems, but has been used frequently for overland flow in urban basins</p>
-----------------------------------------------	---------------------------------------------------------------------------------------------------------------------------------------------------------------------------	----------------------------------------------------------------------------------------------------------------------------------------------------------------------------------------------------------------

For site in the pre-development condition:

$t_c =$ 18.1 minutes

Variable	Value	Unit	Notes
C	0.7	unitless	Represents existing condition of the area ca. 1976-2008, predominantly gravel and hardpack bare soil.
L	656	ft	
S	1.05	%	

Stormwater Management Calculations

Project #160401774, Heatherington Subdivision Modified Rational Method Calculations for Storage

2 yr Intensity City of Ottawa	$I = a/(t + b)^c$	a =	732.951	t (min)	I (mm/hr)
		b =	6.199	10	76.81
		c =	0.81	20	52.03
				30	40.04
				40	32.86
				50	28.04
				60	24.56
				70	21.91
				80	19.83
				90	18.14
				100	16.75
				110	15.57
				120	14.56

2 YEAR Predevelopment Target Release from Portion of Site

Subdrainage Area: Predevelopment Tributary Area to Outlet
 Area (ha): 2.7400
 C: 0.50

Typical Time of Concentration

tc (min)	I (2 yr) (mm/hr)	Qtarget (L/s)
18.1	55.30	210.6

2 YEAR Modified Rational Method for Entire Site

Subdrainage Area: L109A Controlled - Tributary
 Area (ha): 0.15
 C: 0.60

tc (min)	I (2 yr) (mm/hr)	Qactual (L/s)	Qrelease (L/s)	Qstored (L/s)	Vstored (m³)
10	76.81	19.2	19.2	0.0	0.0
20	52.03	13.0	13.0	0.0	0.0
30	40.04	10.0	10.0	0.0	0.0
40	32.86	8.2	8.2	0.0	0.0
50	28.04	7.0	7.0	0.0	0.0
60	24.56	6.1	6.1	0.0	0.0
70	21.91	5.5	5.5	0.0	0.0
80	19.83	5.0	5.0	0.0	0.0
90	18.14	4.5	4.5	0.0	0.0
100	16.75	4.2	4.2	0.0	0.0
110	15.57	3.9	3.9	0.0	0.0
120	14.56	3.6	3.6	0.0	0.0

Stage	Head (m)	Discharge (L/s)	Vreq (cu. m)	Vavail (cu. m)	Volume Check
2-year Water Level	1.38	1.38	19.2	0.0	OK

Subdrainage Area: L108A Controlled - Tributary
 Area (ha): 0.16
 C: 0.60

tc (min)	I (2 yr) (mm/hr)	Qactual (L/s)	Qrelease (L/s)	Qstored (L/s)	Vstored (m³)
10	76.81	20.5	20.5	0.0	0.0
20	52.03	13.9	13.9	0.0	0.0
30	40.04	10.7	10.7	0.0	0.0
40	32.86	8.8	8.8	0.0	0.0
50	28.04	7.5	7.5	0.0	0.0
60	24.56	6.6	6.6	0.0	0.0
70	21.91	5.8	5.8	0.0	0.0
80	19.83	5.3	5.3	0.0	0.0
90	18.14	4.8	4.8	0.0	0.0
100	16.75	4.5	4.5	0.0	0.0
110	15.57	4.2	4.2	0.0	0.0
120	14.56	3.9	3.9	0.0	0.0

Stage	Head (m)	Discharge (L/s)	Vreq (cu. m)	Vavail (cu. m)	Volume Check
2-year Water Level	1.38	1.38	20.5	0.0	OK

Subdrainage Area: L106A Controlled - Tributary
 Area (ha): 0.15
 C: 0.60

tc (min)	I (2 yr) (mm/hr)	Qactual (L/s)	Qrelease (L/s)	Qstored (L/s)	Vstored (m³)
10	76.81	19.2	19.2	0.0	0.0
20	52.03	13.0	13.0	0.0	0.0
30	40.04	10.0	10.0	0.0	0.0
40	32.86	8.2	8.2	0.0	0.0
50	28.04	7.0	7.0	0.0	0.0
60	24.56	6.1	6.1	0.0	0.0
70	21.91	5.5	5.5	0.0	0.0
80	19.83	5.0	5.0	0.0	0.0
90	18.14	4.5	4.5	0.0	0.0
100	16.75	4.2	4.2	0.0	0.0
110	15.57	3.9	3.9	0.0	0.0
120	14.56	3.6	3.6	0.0	0.0

Stage	Head (m)	Discharge (L/s)	Vreq (cu. m)	Vavail (cu. m)	Volume Check
2-year Water Level	1.38	1.38	19.2	0.0	OK

Project #160401774, Heatherington Subdivision Modified Rational Method Calculations for Storage

100 yr Intensity City of Ottawa	$I = a/(t + b)^c$	a =	1735.688	t (min)	I (mm/hr)
		b =	6.014	10	178.56
		c =	0.820	20	119.95
				30	91.87
				40	75.15
				50	63.95
				60	55.89
				70	49.79
				80	44.99
				90	41.11
				100	37.90
				110	35.20
				120	32.89

100 YEAR Predevelopment Target Release from Portion of Site

Subdrainage Area: Predevelopment Tributary Area to Outlet
 Area (ha): 2.7400
 C: 0.50

Typical Time of Concentration

tc (min)	I (100 yr) (mm/hr)	Qtarget (L/s)
18.1	127.65	486.2

100 YEAR Modified Rational Method for Entire Site

Subdrainage Area: L109A Controlled - Tributary
 Area (ha): 0.15
 C: 0.75

tc (min)	I (100 yr) (mm/hr)	Qactual (L/s)	Qrelease (L/s)	Qstored (L/s)	Vstored (m³)
10	178.56	55.8	21.5	34.3	20.6
20	119.95	37.5	21.5	16.0	19.2
30	91.87	28.7	21.5	7.2	13.0
40	75.15	23.5	21.5	2.0	4.8
50	63.95	20.0	20.0	0.0	0.0
60	55.89	17.5	17.5	0.0	0.0
70	49.79	15.6	15.6	0.0	0.0
80	44.99	14.1	14.1	0.0	0.0
90	41.11	12.9	12.9	0.0	0.0
100	37.90	11.9	11.9	0.0	0.0
110	35.20	11.0	11.0	0.0	0.0
120	32.89	10.3	10.3	0.0	0.0

Stage	Head (m)	Discharge (L/s)	Vreq (cu. m)	Vavail (cu. m)	Volume Check
100-year Water Level	1.73	1.73	21.5	20.6	OK

Subdrainage Area: L108A Controlled - Tributary
 Area (ha): 0.16
 C: 0.75

tc (min)	I (100 yr) (mm/hr)	Qactual (L/s)	Qrelease (L/s)	Qstored (L/s)	Vstored (m³)
10	178.56	59.6	23.0	36.6	22.0
20	119.95	40.0	23.0	17.1	20.5
30	91.87	30.6	23.0	7.7	13.9
40	75.15	25.1	23.0	2.1	5.1
50	63.95	21.3	21.3	0.0	0.0
60	55.89	18.6	18.6	0.0	0.0
70	49.79	16.6	16.6	0.0	0.0
80	44.99	15.0	15.0	0.0	0.0
90	41.11	13.7	13.7	0.0	0.0
100	37.90	12.6	12.6	0.0	0.0
110	35.20	11.7	11.7	0.0	0.0
120	32.89	11.0	11.0	0.0	0.0

Stage	Head (m)	Discharge (L/s)	Vreq (cu. m)	Vavail (cu. m)	Volume Check
100-year Water Level	1.73	1.73	23.0	22.0	OK

Subdrainage Area: L106A Controlled - Tributary
 Area (ha): 0.15
 C: 0.75

tc (min)	I (100 yr) (mm/hr)	Qactual (L/s)	Qrelease (L/s)	Qstored (L/s)	Vstored (m³)
10	178.56	55.8	21.5	34.3	20.6
20	119.95	37.5	21.5	16.0	19.2
30	91.87	28.7	21.5	7.2	13.0
40	75.15	23.5	21.5	2.0	4.8
50	63.95	20.0	20.0	0.0	0.0
60	55.89	17.5	17.5	0.0	0.0
70	49.79	15.6	15.6	0.0	0.0
80	44.99	14.1	14.1	0.0	0.0
90	41.11	12.9	12.9	0.0	0.0
100	37.90	11.9	11.9	0.0	0.0
110	35.20	11.0	11.0	0.0	0.0
120	32.89	10.3	10.3	0.0	0.0

Stage	Head (m)	Discharge (L/s)	Vreq (cu. m)	Vavail (cu. m)	Volume Check
100-year Water Level	1.73	1.73	21.5	20.6	OK

Stormwater Management Calculations

Project #160401774, Heatherington Subdivision Modified Rational Method Calculations for Storage

Subdrainage Area: L104A		Controlled - Tributary				
Area (ha): 0.16						
C: 0.60						
tc (min)	I (2 yr) (mm/hr)	Qactual (L/s)	Qrelease (L/s)	Qstored (L/s)	Vstored (m ³)	
10	76.81	20.5	20.5	0.0	0.0	
20	52.03	13.9	13.9	0.0	0.0	
30	40.04	10.7	10.7	0.0	0.0	
40	32.86	8.8	8.8	0.0	0.0	
50	28.04	7.5	7.5	0.0	0.0	
60	24.56	6.6	6.6	0.0	0.0	
70	21.91	5.8	5.8	0.0	0.0	
80	19.83	5.3	5.3	0.0	0.0	
90	18.14	4.8	4.8	0.0	0.0	
100	16.75	4.5	4.5	0.0	0.0	
110	15.57	4.2	4.2	0.0	0.0	
120	14.56	3.9	3.9	0.0	0.0	
Stage	Head (m)	Discharge (L/s)	Vreq (cu. m)	Vavail (cu. m)	Volume Check	
2-year Water Level	1.38	1.38	20.5	0.0	0.0	OK

Subdrainage Area: L103A		Controlled - Tributary				
Area (ha): 0.13						
C: 0.60						
tc (min)	I (2 yr) (mm/hr)	Qactual (L/s)	Qrelease (L/s)	Qstored (L/s)	Vstored (m ³)	
10	76.81	16.7	16.7	0.0	0.0	
20	52.03	11.3	11.3	0.0	0.0	
30	40.04	8.7	8.7	0.0	0.0	
40	32.86	7.1	7.1	0.0	0.0	
50	28.04	6.1	6.1	0.0	0.0	
60	24.56	5.3	5.3	0.0	0.0	
70	21.91	4.8	4.8	0.0	0.0	
80	19.83	4.3	4.3	0.0	0.0	
90	18.14	3.9	3.9	0.0	0.0	
100	16.75	3.6	3.6	0.0	0.0	
110	15.57	3.4	3.4	0.0	0.0	
120	14.56	3.2	3.2	0.0	0.0	
Stage	Head (m)	Discharge (L/s)	Vreq (cu. m)	Vavail (cu. m)	Volume Check	
2-year Water Level	1.38	1.38	16.7	0.0	0.0	OK

Subdrainage Area: L109B		Controlled - Tributary				
Area (ha): 0.23						
C: 0.70						
tc (min)	I (2 yr) (mm/hr)	Qactual (L/s)	Qrelease (L/s)	Qstored (L/s)	Vstored (m ³)	
10	76.81	34.4	12.5	21.9	13.1	
20	52.03	23.3	12.5	10.8	13.0	
30	40.04	17.9	12.5	5.4	9.8	
40	32.86	14.7	12.5	2.2	5.3	
50	28.04	12.6	12.5	0.1	0.2	
60	24.56	11.0	11.0	0.0	0.0	
70	21.91	9.8	9.8	0.0	0.0	
80	19.83	8.9	8.9	0.0	0.0	
90	18.14	8.1	8.1	0.0	0.0	
100	16.75	7.5	7.5	0.0	0.0	
110	15.57	7.0	7.0	0.0	0.0	
120	14.56	6.5	6.5	0.0	0.0	
Stage	Head (m)	Discharge (L/s)	Vreq (cu. m)	Vavail (cu. m)	Volume Check	
2-year Water Level	-	-	12.5	13.1	13.1	OK

Subdrainage Area: L108C		Controlled - Tributary				
Area (ha): 0.15						
C: 0.35						
tc (min)	I (2 yr) (mm/hr)	Qactual (L/s)	Qrelease (L/s)	Qstored (L/s)	Vstored (m ³)	
10	76.81	11.2	11.2	0.0	0.0	
20	52.03	7.6	7.6	0.0	0.0	
30	40.04	5.8	5.8	0.0	0.0	
40	32.86	4.8	4.8	0.0	0.0	
50	28.04	4.1	4.1	0.0	0.0	
60	24.56	3.6	3.6	0.0	0.0	
70	21.91	3.2	3.2	0.0	0.0	
80	19.83	2.9	2.9	0.0	0.0	
90	18.14	2.6	2.6	0.0	0.0	
100	16.75	2.4	2.4	0.0	0.0	
110	15.57	2.3	2.3	0.0	0.0	
120	14.56	2.1	2.1	0.0	0.0	
Stage	Head (m)	Discharge (L/s)	Vreq (cu. m)	Vavail (cu. m)	Volume Check	
2-year Water Level	-	-	11.2	0.0	0.0	OK

Project #160401774, Heatherington Subdivision Modified Rational Method Calculations for Storage

Subdrainage Area: L104A		Controlled - Tributary				
Area (ha): 0.16						
C: 0.75						
tc (min)	I (100 yr) (mm/hr)	Qactual (L/s)	Qrelease (L/s)	Qstored (L/s)	Vstored (m ³)	
10	178.56	59.6	23.0	36.6	22.0	
20	119.95	40.0	23.0	17.1	20.5	
30	91.87	30.6	23.0	7.7	13.9	
40	75.15	25.1	23.0	2.1	5.1	
50	63.95	21.3	21.3	0.0	0.0	
60	55.89	18.6	18.6	0.0	0.0	
70	49.79	16.6	16.6	0.0	0.0	
80	44.99	15.0	15.0	0.0	0.0	
90	41.11	13.7	13.7	0.0	0.0	
100	37.90	12.6	12.6	0.0	0.0	
110	35.20	11.7	11.7	0.0	0.0	
120	32.89	11.0	11.0	0.0	0.0	
Stage	Head (m)	Discharge (L/s)	Vreq (cu. m)	Vavail (cu. m)	Volume Check	
100-year Water Level	1.73	1.73	23.0	22.0	22.0	OK

Subdrainage Area: L103A		Controlled - Tributary				
Area (ha): 0.13						
C: 0.75						
tc (min)	I (100 yr) (mm/hr)	Qactual (L/s)	Qrelease (L/s)	Qstored (L/s)	Vstored (m ³)	
10	178.56	48.4	18.6	29.8	17.9	
20	119.95	32.5	18.6	13.9	16.6	
30	91.87	24.9	18.6	6.3	11.3	
40	75.15	20.4	18.6	1.7	4.1	
50	63.95	17.3	17.3	0.0	0.0	
60	55.89	15.2	15.2	0.0	0.0	
70	49.79	13.5	13.5	0.0	0.0	
80	44.99	12.2	12.2	0.0	0.0	
90	41.11	11.1	11.1	0.0	0.0	
100	37.90	10.3	10.3	0.0	0.0	
110	35.20	9.5	9.5	0.0	0.0	
120	32.89	8.9	8.9	0.0	0.0	
Stage	Head (m)	Discharge (L/s)	Vreq (cu. m)	Vavail (cu. m)	Volume Check	
100-year Water Level	1.73	1.73	18.6	17.9	17.9	OK

Subdrainage Area: L109B		Controlled - Tributary				
Area (ha): 0.23						
C: 0.88						
tc (min)	I (100 yr) (mm/hr)	Qactual (L/s)	Qrelease (L/s)	Qstored (L/s)	Vstored (m ³)	
10	178.56	99.9	42.6	57.3	34.4	
20	119.95	67.1	42.6	24.5	29.4	
30	91.87	51.4	42.6	8.8	15.9	
40	75.15	42.0	42.0	0.0	0.0	
50	63.95	35.8	35.8	0.0	0.0	
60	55.89	31.3	31.3	0.0	0.0	
70	49.79	27.9	27.9	0.0	0.0	
80	44.99	25.2	25.2	0.0	0.0	
90	41.11	23.0	23.0	0.0	0.0	
100	37.90	21.2	21.2	0.0	0.0	
110	35.20	19.7	19.7	0.0	0.0	
120	32.89	18.4	18.4	0.0	0.0	
Stage	Head (m)	Discharge (L/s)	Vreq (cu. m)	Vavail (cu. m)	Volume Check	
100-year Water Level	-	-	42.6	34.4	34.4	OK

Subdrainage Area: L108C		Controlled - Tributary				
Area (ha): 0.15						
C: 0.44						
tc (min)	I (100 yr) (mm/hr)	Qactual (L/s)	Qrelease (L/s)	Qstored (L/s)	Vstored (m ³)	
10	178.56	32.6	32.6	0.0	0.0	
20	119.95	21.9	21.9	0.0	0.0	
30	91.87	16.8	16.8	0.0	0.0	
40	75.15	13.7	13.7	0.0	0.0	
50	63.95	11.7	11.7	0.0	0.0	
60	55.89	10.2	10.2	0.0	0.0	
70	49.79	9.1	9.1	0.0	0.0	
80	44.99	8.2	8.2	0.0	0.0	
90	41.11	7.5	7.5	0.0	0.0	
100	37.90	6.9	6.9	0.0	0.0	
110	35.20	6.4	6.4	0.0	0.0	
120	32.89	6.0	6.0	0.0	0.0	
Stage	Head (m)	Discharge (L/s)	Vreq (cu. m)	Vavail (cu. m)	Volume Check	
100-year Water Level	-	-	32.6	0.0	0.0	OK

Stormwater Management Calculations

Project #160401774, Heatherington Subdivision Modified Rational Method Calculations for Storage

Subdrainage Area: L108B		Controlled - Tributary				
Area (ha): 0.28						
C: 0.70						
tc (min)	I (2 yr) (mm/hr)	Qactual (L/s)	Qrelease (L/s)	Qstored (L/s)	Vstored (m ³)	
10	76.81	41.8	15.2	26.7	16.0	
20	52.03	28.4	15.2	13.2	15.8	
30	40.04	21.8	15.2	6.6	11.9	
40	32.86	17.9	15.2	2.7	6.5	
50	28.04	15.3	15.2	0.1	0.3	
60	24.56	13.4	13.4	0.0	0.0	
70	21.91	11.9	11.9	0.0	0.0	
80	19.83	10.8	10.8	0.0	0.0	
90	18.14	9.9	9.9	0.0	0.0	
100	16.75	9.1	9.1	0.0	0.0	
110	15.57	8.5	8.5	0.0	0.0	
120	14.56	7.9	7.9	0.0	0.0	
Stage (m)	Head (m)	Discharge (L/s)	Vreq (cu. m)	Vavail (cu. m)	Volume Check	
2-year Water Level	-	15.2	16.0	16.0	OK	

Subdrainage Area: L106C		Controlled - Tributary				
Area (ha): 0.46						
C: 0.70						
tc (min)	I (2 yr) (mm/hr)	Qactual (L/s)	Qrelease (L/s)	Qstored (L/s)	Vstored (m ³)	
10	76.81	68.8	25.0	43.8	26.3	
20	52.03	46.6	25.0	21.6	25.9	
30	40.04	35.8	25.0	10.9	19.6	
40	32.86	29.4	25.0	4.5	10.7	
50	28.04	25.1	25.0	0.1	0.4	
60	24.56	22.0	22.0	0.0	0.0	
70	21.91	19.6	19.6	0.0	0.0	
80	19.83	17.8	17.8	0.0	0.0	
90	18.14	16.2	16.2	0.0	0.0	
100	16.75	15.0	15.0	0.0	0.0	
110	15.57	13.9	13.9	0.0	0.0	
120	14.56	13.0	13.0	0.0	0.0	
Stage (m)	Head (m)	Discharge (L/s)	Vreq (cu. m)	Vavail (cu. m)	Volume Check	
2-year Water Level	-	25.0	26.3	26.3	OK	

Subdrainage Area: L106B		Controlled - Tributary				
Area (ha): 0.22						
C: 0.70						
tc (min)	I (2 yr) (mm/hr)	Qactual (L/s)	Qrelease (L/s)	Qstored (L/s)	Vstored (m ³)	
10	76.81	32.9	11.9	20.9	12.6	
20	52.03	22.3	11.9	10.3	12.4	
30	40.04	17.1	11.9	5.2	9.4	
40	32.86	14.1	11.9	2.1	5.1	
50	28.04	12.0	11.9	0.1	0.2	
60	24.56	10.5	10.5	0.0	0.0	
70	21.91	9.4	9.4	0.0	0.0	
80	19.83	8.5	8.5	0.0	0.0	
90	18.14	7.8	7.8	0.0	0.0	
100	16.75	7.2	7.2	0.0	0.0	
110	15.57	6.7	6.7	0.0	0.0	
120	14.56	6.2	6.2	0.0	0.0	
Stage (m)	Head (m)	Discharge (L/s)	Vreq (cu. m)	Vavail (cu. m)	Volume Check	
2-year Water Level	-	11.9	12.6	12.6	OK	

Subdrainage Area: L104C		Controlled - Tributary				
Area (ha): 0.17						
C: 0.35						
tc (min)	I (2 yr) (mm/hr)	Qactual (L/s)	Qrelease (L/s)	Qstored (L/s)	Vstored (m ³)	
10	76.81	12.7	12.7	0.0	0.0	
20	52.03	8.6	8.6	0.0	0.0	
30	40.04	6.6	6.6	0.0	0.0	
40	32.86	5.4	5.4	0.0	0.0	
50	28.04	4.6	4.6	0.0	0.0	
60	24.56	4.1	4.1	0.0	0.0	
70	21.91	3.6	3.6	0.0	0.0	
80	19.83	3.3	3.3	0.0	0.0	
90	18.14	3.0	3.0	0.0	0.0	
100	16.75	2.8	2.8	0.0	0.0	
110	15.57	2.6	2.6	0.0	0.0	
120	14.56	2.4	2.4	0.0	0.0	
Stage (m)	Head (m)	Discharge (L/s)	Vreq (cu. m)	Vavail (cu. m)	Volume Check	
2-year Water Level	-	12.7	0.0	0.0	OK	

Project #160401774, Heatherington Subdivision Modified Rational Method Calculations for Storage

Subdrainage Area: L108B		Controlled - Tributary				
Area (ha): 0.88						
C: 0.88						
tc (min)	I (100 yr) (mm/hr)	Qactual (L/s)	Qrelease (L/s)	Qstored (L/s)	Vstored (m ³)	
10	178.56	121.6	51.8	69.8	41.9	
20	119.95	81.7	51.8	29.9	35.9	
30	91.87	62.6	51.8	10.7	19.3	
40	75.15	51.2	51.2	0.0	0.0	
50	63.95	43.6	43.6	0.0	0.0	
60	55.89	38.1	38.1	0.0	0.0	
70	49.79	33.9	33.9	0.0	0.0	
80	44.99	30.6	30.6	0.0	0.0	
90	41.11	28.0	28.0	0.0	0.0	
100	37.90	25.8	25.8	0.0	0.0	
110	35.20	24.0	24.0	0.0	0.0	
120	32.89	22.4	22.4	0.0	0.0	
Stage (m)	Head (m)	Discharge (L/s)	Vreq (cu. m)	Vavail (cu. m)	Volume Check	
100-year Water Level	-	51.8	41.9	41.9	OK	0.00

Subdrainage Area: L106C		Controlled - Tributary				
Area (ha): 0.46						
C: 0.88						
tc (min)	I (100 yr) (mm/hr)	Qactual (L/s)	Qrelease (L/s)	Qstored (L/s)	Vstored (m ³)	
10	178.56	199.8	85.1	114.7	68.8	
20	119.95	134.2	85.1	49.1	58.9	
30	91.87	102.8	85.1	17.7	31.8	
40	75.15	84.1	84.1	0.0	0.0	
50	63.95	71.6	71.6	0.0	0.0	
60	55.89	62.5	62.5	0.0	0.0	
70	49.79	55.7	55.7	0.0	0.0	
80	44.99	50.3	50.3	0.0	0.0	
90	41.11	46.0	46.0	0.0	0.0	
100	37.90	42.4	42.4	0.0	0.0	
110	35.20	39.4	39.4	0.0	0.0	
120	32.89	36.8	36.8	0.0	0.0	
Stage (m)	Head (m)	Discharge (L/s)	Vreq (cu. m)	Vavail (cu. m)	Volume Check	
100-year Water Level	-	85.1	68.8	68.8	OK	0.00

Subdrainage Area: L106B		Controlled - Tributary				
Area (ha): 0.22						
C: 0.88						
tc (min)	I (100 yr) (mm/hr)	Qactual (L/s)	Qrelease (L/s)	Qstored (L/s)	Vstored (m ³)	
10	178.56	95.6	40.7	54.8	32.9	
20	119.95	64.2	40.7	23.5	28.2	
30	91.87	49.2	40.7	8.4	15.2	
40	75.15	40.2	40.2	0.0	0.0	
50	63.95	34.2	34.2	0.0	0.0	
60	55.89	29.9	29.9	0.0	0.0	
70	49.79	26.6	26.6	0.0	0.0	
80	44.99	24.1	24.1	0.0	0.0	
90	41.11	22.0	22.0	0.0	0.0	
100	37.90	20.3	20.3	0.0	0.0	
110	35.20	18.8	18.8	0.0	0.0	
120	32.89	17.6	17.6	0.0	0.0	
Stage (m)	Head (m)	Discharge (L/s)	Vreq (cu. m)	Vavail (cu. m)	Volume Check	
100-year Water Level	-	40.7	32.9	32.9	OK	0.0

Subdrainage Area: L104C		Controlled - Tributary				
Area (ha): 0.17						
C: 0.44						
tc (min)	I (100 yr) (mm/hr)	Qactual (L/s)	Qrelease (L/s)	Qstored (L/s)	Vstored (m ³)	
10	178.56	36.9	36.9	0.0	0.0	
20	119.95	24.8	24.8	0.0	0.0	
30	91.87	19.0	19.0	0.0	0.0	
40	75.15	15.5	15.5	0.0	0.0	
50	63.95	13.2	13.2	0.0	0.0	
60	55.89	11.6	11.6	0.0	0.0	
70	49.79	10.3	10.3	0.0	0.0	
80	44.99	9.3	9.3	0.0	0.0	
90	41.11	8.5	8.5	0.0	0.0	
100	37.90	7.8	7.8	0.0	0.0	
110	35.20	7.3	7.3	0.0	0.0	
120	32.89	6.8	6.8	0.0	0.0	
Stage (m)	Head (m)	Discharge (L/s)	Vreq (cu. m)	Vavail (cu. m)	Volume Check	
100-year Water Level	-	36.9	0.0	0.0	OK	0.00

Stormwater Management Calculations

Project #160401774, Heatherington Subdivision Modified Rational Method Calculations for Storage

Subdrainage Area: L103B		Controlled - Tributary			
Area (ha): 0.20					
C: 0.70					
tc (min)	I (2 yr) (mm/hr)	Qactual (L/s)	Qrelease (L/s)	Qstored (L/s)	Vstored (m³)
10	76.81	29.9	10.9	19.0	11.4
20	52.03	20.3	10.9	9.4	11.3
30	40.04	15.6	10.9	4.7	8.5
40	32.86	12.8	10.9	1.9	4.6
50	28.04	10.9	10.9	0.1	0.2
60	24.56	9.6	9.6	0.0	0.0
70	21.91	8.5	8.5	0.0	0.0
80	19.83	7.7	7.7	0.0	0.0
90	18.14	7.1	7.1	0.0	0.0
100	16.75	6.5	6.5	0.0	0.0
110	15.57	6.1	6.1	0.0	0.0
120	14.56	5.7	5.7	0.0	0.0
Stage (m)	Head (m)	Discharge (L/s)	Vreq (cu. m)	Vavail (cu. m)	Volume Check
2-year Water Level	-	10.9	11.4	11.4	OK

Subdrainage Area: L104B		Controlled - Tributary			
Area (ha): 0.28					
C: 0.70					
tc (min)	I (2 yr) (mm/hr)	Qactual (L/s)	Qrelease (L/s)	Qstored (L/s)	Vstored (m³)
10	76.81	41.8	15.2	26.7	16.0
20	52.03	28.4	15.2	13.2	15.8
30	40.04	21.8	15.2	6.6	11.9
40	32.86	17.9	15.2	2.7	6.5
50	28.04	15.3	15.2	0.1	0.3
60	24.56	13.4	13.4	0.0	0.0
70	21.91	11.9	11.9	0.0	0.0
80	19.83	10.8	10.8	0.0	0.0
90	18.14	9.9	9.9	0.0	0.0
100	16.75	9.1	9.1	0.0	0.0
110	15.57	8.5	8.5	0.0	0.0
120	14.56	7.9	7.9	0.0	0.0
Stage (m)	Head (m)	Discharge (L/s)	Vreq (cu. m)	Vavail (cu. m)	Volume Check
2-year Water Level	-	15.2	16.0	16.0	OK

SUMMARY TO OUTLET				
Tributary Area	2.74	ha	Vrequired	Vavailable*
Total 2yr Flow to Sewer	210.6	L/s	95	95 m ³
Allowable 2yr Flow	210.6	L/s		

Project #160401774, Heatherington Subdivision Modified Rational Method Calculations for Storage

Subdrainage Area: L103B		Controlled - Tributary			
Area (ha): 0.20					
C: 0.88					
tc (min)	I (100 yr) (mm/hr)	Qactual (L/s)	Qrelease (L/s)	Qstored (L/s)	Vstored (m³)
10	178.56	86.9	37.0	49.9	29.9
20	119.95	58.4	37.0	21.3	25.6
30	91.87	44.7	37.0	7.7	13.8
40	75.15	36.6	36.6	0.0	0.0
50	63.95	31.1	31.1	0.0	0.0
60	55.89	27.2	27.2	0.0	0.0
70	49.79	24.2	24.2	0.0	0.0
80	44.99	21.9	21.9	0.0	0.0
90	41.11	20.0	20.0	0.0	0.0
100	37.90	18.4	18.4	0.0	0.0
110	35.20	17.1	17.1	0.0	0.0
120	32.89	16.0	16.0	0.0	0.0
Stage (m)	Head (m)	Discharge (L/s)	Vreq (cu. m)	Vavail (cu. m)	Volume Check
100-year Water Level	-	37.0	29.9	29.9	OK

Subdrainage Area: L104B		Controlled - Tributary			
Area (ha): 0.28					
C: 0.88					
tc (min)	I (100 yr) (mm/hr)	Qactual (L/s)	Qrelease (L/s)	Qstored (L/s)	Vstored (m³)
10	178.56	121.6	51.8	69.8	41.9
20	119.95	81.7	51.8	29.9	35.9
30	91.87	62.6	51.8	10.7	19.3
40	75.15	51.2	51.2	0.0	0.0
50	63.95	43.6	43.6	0.0	0.0
60	55.89	38.1	38.1	0.0	0.0
70	49.79	33.9	33.9	0.0	0.0
80	44.99	30.6	30.6	0.0	0.0
90	41.11	28.0	28.0	0.0	0.0
100	37.90	25.8	25.8	0.0	0.0
110	35.20	24.0	24.0	0.0	0.0
120	32.89	22.4	22.4	0.0	0.0
Stage (m)	Head (m)	Discharge (L/s)	Vreq (cu. m)	Vavail (cu. m)	Volume Check
100-year Water Level	-	51.8	41.9	41.9	OK

SUMMARY TO OUTLET				
Tributary Area	2.74	ha	Vrequired	Vavailable*
Total 100yr Flow to Sewer	486.2	L/s	353	353 m ³
Allowable 100yr Flow	486.2	L/s		

C.3 OGS UNIT SIZING CALCULATIONS



Stormceptor® EF Sizing Report

Imbrium® Systems

ESTIMATED NET ANNUAL SEDIMENT (TSS) LOAD REDUCTION

11/08/2023

Province:	Ontario	Project Name:	1770 Heatherington Road
City:	Ottawa	Project Number:	160401774
Nearest Rainfall Station:	OTTAWA CDA RCS	Designer Name:	Krystian David Chochlinski
Climate Station Id:	6105978	Designer Company:	Stantec
Years of Rainfall Data:	20	Designer Email:	krystian.chochlinski@stantec.com
Site Name:		Designer Phone:	613-355-4388
Drainage Area (ha):	2.74	EOR Name:	
Runoff Coefficient 'c':	0.59	EOR Company:	
Particle Size Distribution:	Fine	EOR Email:	
Target TSS Removal (%):	80.0	EOR Phone:	

Required Water Quality Runoff Volume Capture (%):	
Estimated Water Quality Flow Rate (L/s):	52.18
Oil / Fuel Spill Risk Site?	Yes
Upstream Flow Control?	No
Peak Conveyance (maximum) Flow Rate (L/s):	
Influent TSS Concentration (mg/L):	
Estimated Average Annual Sediment Volume (L/yr):	2765

Net Annual Sediment (TSS) Load Reduction Sizing Summary	
Stormceptor Model	TSS Removal Provided (%)
EFO4	63
EFO6	77
EFO8	85
EFO10	90
EFO12	94

Recommended Stormceptor EFO Model: EFO8
Estimated Net Annual Sediment (TSS) Load Reduction (%): 85
Water Quality Runoff Volume Capture (%): > 90



THIRD-PARTY TESTING AND VERIFICATION

► **Stormceptor® EF and Stormceptor® EFO** are the latest evolutions in the Stormceptor® oil-grit separator (OGS) technology series, and are designed to remove a wide variety of pollutants from stormwater and snowmelt runoff. These technologies have been third-party tested in accordance with the Canadian ETV **Procedure for Laboratory Testing of Oil-Grit Separators** and performance has been third-party verified in accordance with the **ISO 14034 Environmental Technology Verification (ETV)** protocol.

PERFORMANCE

► **Stormceptor® EF and EFO** remove stormwater pollutants through gravity separation and floatation, and feature a patent-pending design that generates positive removal of total suspended solids (TSS) throughout each storm event, including high-intensity storms. Captured pollutants include sediment, free oils, and sediment-bound pollutants such as nutrients, heavy metals, and petroleum hydrocarbons. Stormceptor is sized to remove a high level of TSS from the frequent rainfall events that contribute the vast majority of annual runoff volume and pollutant load. The technology incorporates an internal bypass to convey excessive stormwater flows from high-intensity storms through the device without resuspension and washout (scour) of previously captured pollutants. Proper routine maintenance ensures high pollutant removal performance and protection of downstream waterways.

PARTICLE SIZE DISTRIBUTION (PSD)

► The **Canadian ETV PSD** shown in the table below was used, or in part, for this sizing. This is the identical PSD that is referenced in the Canadian ETV **Procedure for Laboratory Testing of Oil-Grit Separators** for both sediment removal testing and scour testing. The Canadian ETV PSD contains a wide range of particle sizes in the sand and silt fractions, and is considered reasonably representative of the particle size fractions found in typical urban stormwater runoff.

Particle Size (µm)	Percent Less Than	Particle Size Fraction (µm)	Percent
1000	100	500-1000	5
500	95	250-500	5
250	90	150-250	15
150	75	100-150	15
100	60	75-100	10
75	50	50-75	5
50	45	20-50	10
20	35	8-20	15
8	20	5-8	10
5	10	2-5	5
2	5	<2	5

Stormceptor® EF Sizing Report

Rainfall Intensity (mm / hr)	Percent Rainfall Volume (%)	Cumulative Rainfall Volume (%)	Flow Rate (L/s)	Flow Rate (L/min)	Surface Loading Rate (L/min/m ²)	Removal Efficiency (%)	Incremental Removal (%)	Cumulative Removal (%)
0.50	8.6	8.6	2.25	135.0	29.0	100	8.6	8.6
1.00	20.3	29.0	4.49	270.0	57.0	100	20.3	29.0
2.00	16.2	45.2	8.99	539.0	115.0	95	15.3	44.3
3.00	12.0	57.2	13.48	809.0	172.0	87	10.4	54.7
4.00	8.4	65.6	17.98	1079.0	229.0	82	6.9	61.6
5.00	5.9	71.6	22.47	1348.0	287.0	79	4.7	66.4
6.00	4.6	76.2	26.96	1618.0	344.0	77	3.5	69.9
7.00	3.1	79.3	31.46	1888.0	402.0	74	2.3	72.2
8.00	2.7	82.0	35.95	2157.0	459.0	72	2.0	74.1
9.00	3.3	85.3	40.45	2427.0	516.0	69	2.3	76.4
10.00	2.3	87.6	44.94	2696.0	574.0	66	1.5	77.9
11.00	1.6	89.2	49.44	2966.0	631.0	64	1.0	78.9
12.00	1.3	90.5	53.93	3236.0	688.0	64	0.8	79.8
13.00	1.7	92.2	58.42	3505.0	746.0	64	1.1	80.9
14.00	1.2	93.5	62.92	3775.0	803.0	63	0.8	81.7
15.00	1.2	94.6	67.41	4045.0	861.0	63	0.7	82.4
16.00	0.7	95.3	71.91	4314.0	918.0	62	0.4	82.8
17.00	0.7	96.1	76.40	4584.0	975.0	62	0.5	83.3
18.00	0.4	96.5	80.89	4854.0	1033.0	61	0.2	83.5
19.00	0.4	96.9	85.39	5123.0	1090.0	59	0.2	83.8
20.00	0.2	97.1	89.88	5393.0	1147.0	58	0.1	83.9
21.00	0.5	97.5	94.38	5663.0	1205.0	57	0.3	84.1
22.00	0.2	97.8	98.87	5932.0	1262.0	56	0.1	84.3
23.00	1.0	98.8	103.37	6202.0	1320.0	54	0.5	84.8
24.00	0.3	99.1	107.86	6472.0	1377.0	53	0.1	85.0
25.00	0.0	99.1	112.35	6741.0	1434.0	51	0.0	85.0
30.00	0.9	100.0	134.82	8089.0	1721.0	43	0.4	85.4
35.00	0.0	100.0	157.30	9438.0	2008.0	37	0.0	85.4
40.00	0.0	100.0	179.77	10786.0	2295.0	32	0.0	85.4
45.00	0.0	100.0	202.24	12134.0	2582.0	28	0.0	85.4
Estimated Net Annual Sediment (TSS) Load Reduction =								85 %

Climate Station ID: 6105978 Years of Rainfall Data: 20

Stormceptor® EF Sizing Report

RAINFALL DATA FROM OTTAWA CDA RCS RAINFALL STATION

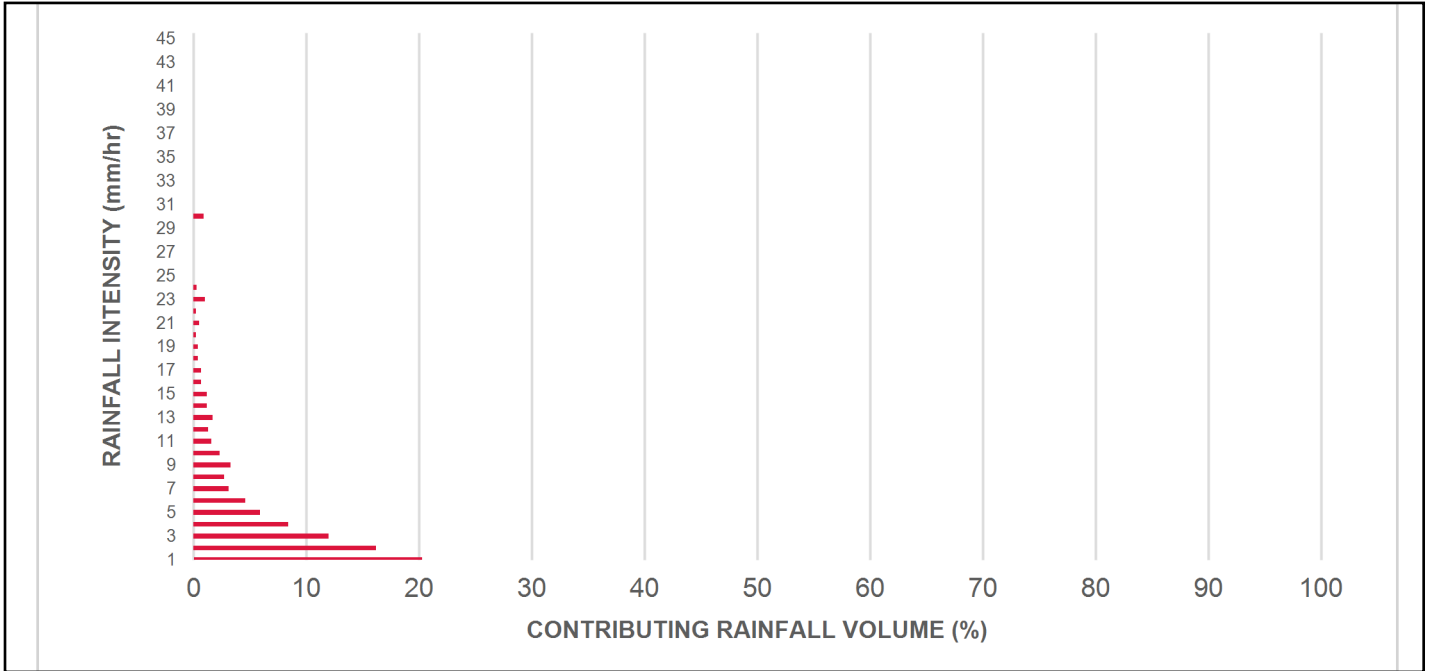

INCREMENTAL AND CUMULATIVE TSS REMOVAL FOR THE RECOMMENDED STORMCEPTOR® MODEL

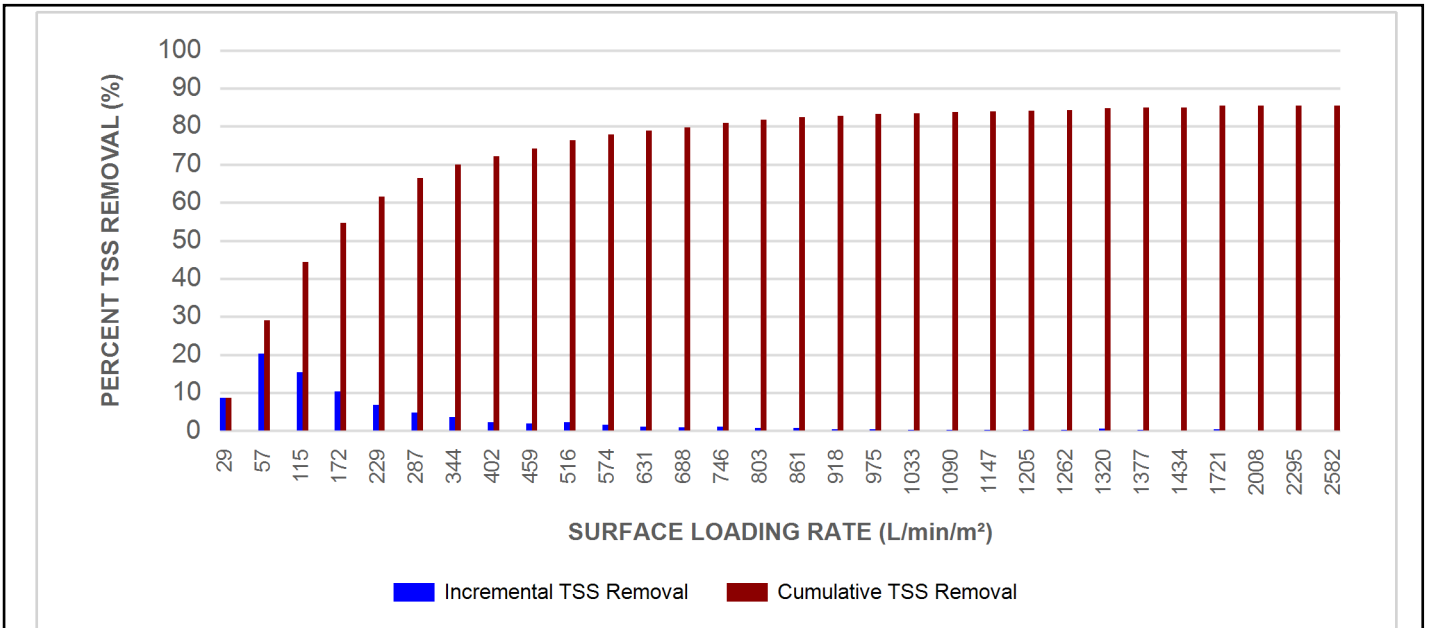

Stormceptor® EF Sizing Report

Maximum Pipe Diameter / Peak Conveyance

Stormceptor EF / EFO	Model Diameter		Min Angle Inlet / Outlet Pipes	Max Inlet Pipe Diameter		Max Outlet Pipe Diameter		Peak Conveyance Flow Rate	
	(m)	(ft)		(mm)	(in)	(mm)	(in)	(L/s)	(cfs)
EF4 / EFO4	1.2	4	90	609	24	609	24	425	15
EF6 / EFO6	1.8	6	90	914	36	914	36	990	35
EF8 / EFO8	2.4	8	90	1219	48	1219	48	1700	60
EF10 / EFO10	3.0	10	90	1828	72	1828	72	2830	100
EF12 / EFO12	3.6	12	90	1828	72	1828	72	2830	100

SCOUR PREVENTION AND ONLINE CONFIGURATION

► Stormceptor® EF and EFO feature an internal bypass and superior scour prevention technology that have been demonstrated in third-party testing according to the scour testing provisions of the Canadian ETV **Procedure for Laboratory Testing of Oil-Grit Separators**, and the exceptional scour test performance has been third-party verified in accordance with the ISO 14034 ETV protocol. As a result, Stormceptor EF and EFO are approved for online installation, eliminating the need for costly additional bypass structures, piping, and installation expense.

DESIGN FLEXIBILITY

► Stormceptor® EF and EFO offers design flexibility in one simplified platform, accepting stormwater flow from a single inlet pipe or multiple inlet pipes, and/or surface runoff through an inlet grate. The device can also serve as a junction structure, accommodate a 90-degree inlet-to-outlet bend angle, and can be modified to ensure performance in submerged conditions.

OIL CAPTURE AND RETENTION

► While Stormceptor® EF will capture and retain oil from dry weather spills and low intensity runoff, Stormceptor® EFO has demonstrated superior oil capture and greater than 99% oil retention in third-party testing according to the light liquid re-entrainment testing provisions of the Canadian ETV **Procedure for Laboratory Testing of Oil-Grit Separators**. Stormceptor EFO is recommended for sites where oil capture and retention is a requirement.

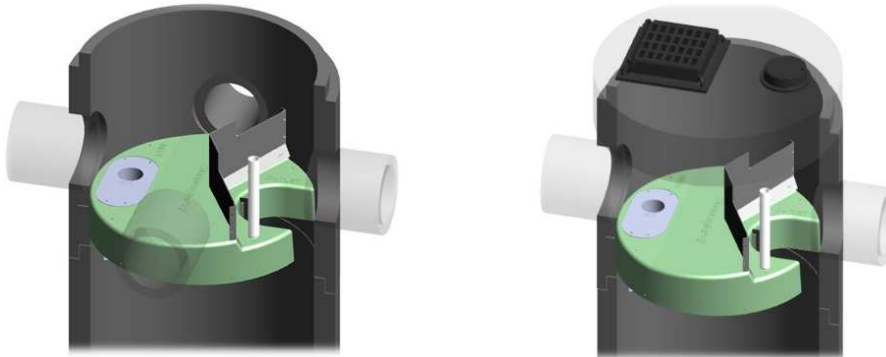

Stormceptor® EF Sizing Report

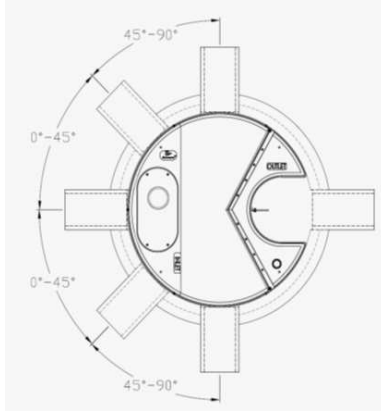

INLET-TO-OUTLET DROP

Elevation differential between inlet and outlet pipe inverts is dictated by the angle at which the inlet pipe(s) enters the unit.

0° - 45° : The inlet pipe is 1-inch (25mm) higher than the outlet pipe.

45° - 90° : The inlet pipe is 2-inches (50mm) higher than the outlet pipe.

HEAD LOSS

The head loss through Stormceptor EF is similar to that of a 60-degree bend structure. The applicable K value for calculating minor losses through the unit is 1.1. For submerged conditions the applicable K value is 3.0.

Pollutant Capacity

Stormceptor EF / EFO	Model Diameter		Depth (Outlet Pipe Invert to Sump Floor)		Oil Volume		Recommended Sediment Maintenance Depth *		Maximum Sediment Volume *		Maximum Sediment Mass **	
	(m)	(ft)	(m)	(ft)	(L)	(Gal)	(mm)	(in)	(L)	(ft³)	(kg)	(lb)
EF4 / EFO4	1.2	4	1.52	5.0	265	70	203	8	1190	42	1904	5250
EF6 / EFO6	1.8	6	1.93	6.3	610	160	305	12	3470	123	5552	15375
EF8 / EFO8	2.4	8	2.59	8.5	1070	280	610	24	8780	310	14048	38750
EF10 / EFO10	3.0	10	3.25	10.7	1670	440	610	24	17790	628	28464	78500
EF12 / EFO12	3.6	12	3.89	12.8	2475	655	610	24	31220	1103	49952	137875

*Increased sump depth may be added to increase sediment storage capacity

** Average density of wet packed sediment in sump = 1.6 kg/L (100 lb/ft³)

Feature	Benefit	Feature Appeals To
Patent-pending enhanced flow treatment and scour prevention technology	Superior, verified third-party performance	Regulator, Specifying & Design Engineer
Third-party verified light liquid capture and retention for EFO version	Proven performance for fuel/oil hotspot locations	Regulator, Specifying & Design Engineer, Site Owner
Functions as bend, junction or inlet structure	Design flexibility	Specifying & Design Engineer
Minimal drop between inlet and outlet	Site installation ease	Contractor
Large diameter outlet riser for inspection and maintenance	Easy maintenance access from grade	Maintenance Contractor & Site Owner

STANDARD STORMCEPTOR EF/EFO DRAWINGS

For standard details, please visit <http://www.imbriumsystems.com/stormwater-treatment-solutions/stormceptor-ef>

STANDARD STORMCEPTOR EF/EFO SPECIFICATION

For specifications, please visit <http://www.imbriumsystems.com/stormwater-treatment-solutions/stormceptor-ef>

STANDARD PERFORMANCE SPECIFICATION FOR “OIL GRIT SEPARATOR” (OGS) STORMWATER QUALITY TREATMENT DEVICE

PART 1 – GENERAL

1.1 WORK INCLUDED

This section specifies requirements for selecting, sizing, and designing an underground Oil Grit Separator (OGS) device for stormwater quality treatment, with third-party testing results and a Statement of Verification in accordance with ISO 14034 Environmental Management – Environmental Technology Verification (ETV).

1.2 REFERENCE STANDARDS & PROCEDURES

ISO 14034:2016 Environmental management – Environmental technology verification (ETV)

Canadian Environmental Technology Verification (ETV) Program’s **Procedure for Laboratory Testing of Oil-Grit Separators**

1.3 SUBMITTALS

1.3.1 All submittals, including sizing reports & shop drawings, shall be submitted upon request with each order to the contractor then forwarded to the Engineer of Record for review and acceptance. Shop drawings shall detail all OGS components, elevations, and sequence of construction.

1.3.2 Alternative devices shall have features identical to or greater than the specified device, including: treatment chamber diameter, treatment chamber wet volume, sediment storage volume, and oil storage volume.

1.3.3 Unless directed otherwise by the Engineer of Record, OGS stormwater quality treatment product substitutions or alternatives submitted within ten days prior to project bid shall not be accepted. All alternatives or substitutions submitted shall be signed and sealed by a local registered Professional Engineer, based on the exact same criteria detailed in Section 3, in entirety, subject to review and approval by the Engineer of Record.

PART 2 – PRODUCTS

2.1 OGS POLLUTANT STORAGE

The OGS device shall include a sump for sediment storage, and a protected volume for the capture and storage of petroleum hydrocarbons and buoyant gross pollutants. The minimum sediment & petroleum hydrocarbon storage capacity shall be as follows:

2.1.1	4 ft (1219 mm) Diameter OGS Units:	1.19 m ³ sediment / 265 L oil
	6 ft (1829 mm) Diameter OGS Units:	3.48 m ³ sediment / 609 L oil
	8 ft (2438 mm) Diameter OGS Units:	8.78 m ³ sediment / 1,071 L oil
	10 ft (3048 mm) Diameter OGS Units:	17.78 m ³ sediment / 1,673 L oil
	12 ft (3657 mm) Diameter OGS Units:	31.23 m ³ sediment / 2,476 L oil

PART 3 – PERFORMANCE & DESIGN

3.1 GENERAL

The OGS stormwater quality treatment device shall be verified in accordance with ISO 14034:2016 Environmental management – Environmental technology verification (ETV). The OGS stormwater quality treatment device shall

Stormceptor® EF Sizing Report

remove oil, sediment and gross pollutants from stormwater runoff during frequent wet weather events, and retain these pollutants during less frequent high flow wet weather events below the insert within the OGS for later removal during maintenance. The Manufacturer shall have at least ten (10) years of local experience, history and success in engineering design, manufacturing and production and supply of OGS stormwater quality treatment device systems, acceptable to the Engineer of Record.

3.2 SIZING METHODOLOGY

The OGS device shall be engineered, designed and sized to provide stormwater quality treatment based on treating a minimum of 90 percent of the average annual runoff volume and a minimum removal of an annual average 60% of the sediment (TSS) load based on the Particle Size Distribution (PSD) specified in the sizing report for the specified device. Sizing of the OGS shall be determined by use of a minimum ten (10) years of local historical rainfall data provided by Environment Canada. Sizing shall also be determined by use of the sediment removal performance data derived from the ISO 14034 ETV third-party verified laboratory testing data from testing conducted in accordance with the Canadian ETV protocol Procedure for Laboratory Testing of Oil-Grit Separators, as follows:

3.2.1 Sediment removal efficiency for a given surface loading rate and its associated flow rate shall be based on sediment removal efficiency demonstrated at the seven (7) tested surface loading rates specified in the protocol, ranging 40 L/min/m² to 1400 L/min/m², and as stated in the ISO 14034 ETV Verification Statement for the OGS device.

3.2.2 Sediment removal efficiency for surface loading rates between 40 L/min/m² and 1400 L/min/m² shall be based on linear interpolation of data between consecutive tested surface loading rates.

3.2.3 Sediment removal efficiency for surface loading rates less than the lowest tested surface loading rate of 40 L/min/m² shall be assumed to be identical to the sediment removal efficiency at 40 L/min/m². No extrapolation shall be allowed that results in a sediment removal efficiency that is greater than that demonstrated at 40 L/min/m².

3.2.4 Sediment removal efficiency for surface loading rates greater than the highest tested surface loading rate of 1400 L/min/m² shall assume zero sediment removal for the portion of flow that exceeds 1400 L/min/m², and shall be calculated using a simple proportioning formula, with 1400 L/min/m² in the numerator and the higher surface loading rate in the denominator, and multiplying the resulting fraction times the sediment removal efficiency at 1400 L/min/m².

The OGS device shall also have sufficient annual sediment storage capacity as specified and calculated in Section 2.1.

3.3 CANADIAN ETV or ISO 14034 ETV VERIFICATION OF SCOUR TESTING

The OGS device shall have Canadian ETV or ISO 14034 ETV Verification of third-party scour testing conducted in accordance with the Canadian ETV Program's **Procedure for Laboratory Testing of Oil-Grit Separators**.

3.3.1 To be acceptable for on-line installation, the OGS device must demonstrate an average scour test effluent concentration less than 10 mg/L at each surface loading rate tested, up to and including 2600 L/min/m².

3.4 LIGHT LIQUID RE-ENTRAINMENT SIMULATION TESTING

The OGS device shall have Canadian ETV or ISO 14034 ETV Verification of completed third-party Light Liquid Re-entrainment Simulation Testing in accordance with the Canadian ETV **Program's Procedure for Laboratory Testing of Oil-Grit Separators**, with results reported within the Canadian ETV or ISO 14034 ETV verification. This re-entrainment testing is conducted with the device pre-loaded with low density polyethylene (LDPE) plastic beads as a surrogate for light liquids such as oil and fuel. Testing is conducted on the same OGS unit tested for sediment removal to

Stormceptor® EF Sizing Report

assess whether light liquids captured after a spill are effectively retained at high flow rates.

3.4.1 For an OGS device to be an acceptable stormwater treatment device on a site where vehicular traffic occurs and the potential for an oil or fuel spill exists, the OGS device must have reported verified performance results of greater than 99% cumulative retention of LDPE plastic beads for the five specified surface loading rates (ranging 200 L/min/m² to 2600 L/min/m²) in accordance with the Light Liquid Re-entrainment Simulation Testing within the Canadian ETV Program's **Procedure for Laboratory Testing of Oil-Grit Separators**. However, an OGS device shall not be allowed if the Light Liquid Re-entrainment Simulation Testing was performed with screening components within the OGS device that are effective at retaining the LDPE plastic beads, but would not be expected to retain light liquids such as oil and fuel.

DRAWING NOT TO BE USED FOR CONSTRUCTION

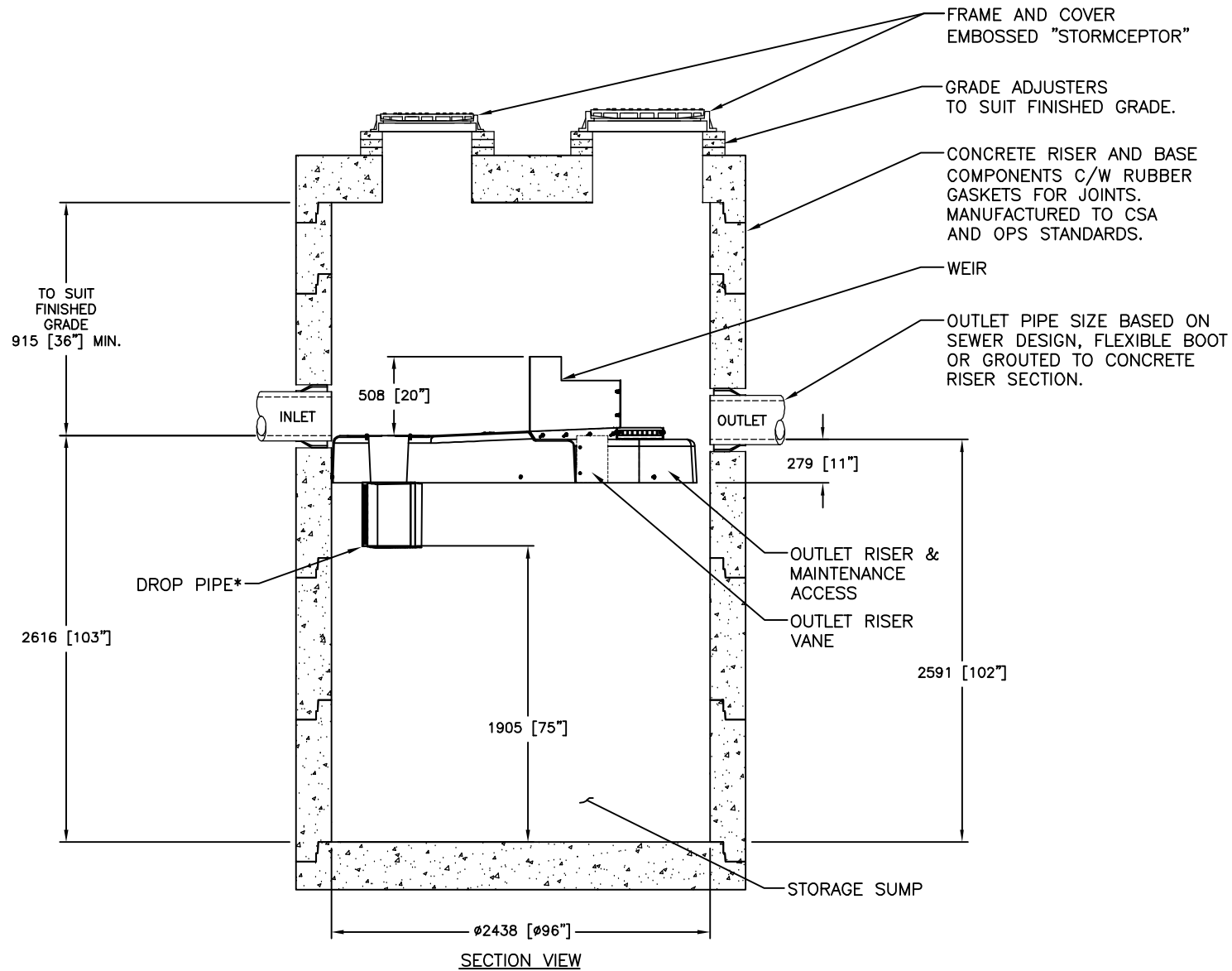

GENERAL NOTES:

- * MAXIMUM SURFACE LOADING RATE (SLR) INTO LOWER CHAMBER THROUGH DROP PIPE IS 1135 L/min/m² (27.9 gpm/ft²) FOR STORMCEPTOR EF8 AND 535 L/min/m² (13.1 gpm/ft²) FOR STORMCEPTOR EFO8 (OIL CAPTURE CONFIGURATION).
- ALL DIMENSIONS INDICATED ARE IN MILLIMETERS (INCHES) UNLESS OTHERWISE SPECIFIED.
- STORMCEPTOR STRUCTURE INLET AND OUTLET PIPE SIZE AND ORIENTATION SHOWN FOR INFORMATIONAL PURPOSES ONLY.
- UNLESS OTHERWISE NOTED, BYPASS INFRASTRUCTURE, SUCH AS ALL UPSTREAM DIVERSION STRUCTURES, CONNECTING STRUCTURES, OR PIPE CONDUITS CONNECTING TO COMPLETE THE STORMCEPTOR SYSTEM SHALL BE PROVIDED AND ADDRESSED SEPARATELY.
- DRAWING FOR INFORMATIONAL PURPOSES ONLY. REFER TO ENGINEER'S SITE/UTILITY PLAN FOR STRUCTURE ORIENTATION.
- NO PRODUCT SUBSTITUTIONS SHALL BE ACCEPTED UNLESS SUBMITTED 10 DAYS PRIOR TO PROJECT BID DATE, OR AS DIRECTED BY THE ENGINEER OF RECORD.

INSTALLATION NOTES

- ANY SUB-BASE, BACKFILL DEPTH, AND/OR ANTI-FLOTATION PROVISIONS ARE SITE-SPECIFIC DESIGN CONSIDERATIONS AND SHALL BE SPECIFIED BY ENGINEER OF RECORD.
- CONTRACTOR TO PROVIDE EQUIPMENT WITH SUFFICIENT LIFTING AND REACH CAPACITY TO LIFT AND SET THE STRUCTURE (LIFTING CLUTCHES PROVIDED)
- CONTRACTOR WILL INSTALL AND LEVEL THE STRUCTURE, SEALING THE JOINTS, LINE ENTRY AND EXIT POINTS (NON-SHRINK GROUT WITH APPROVED WATERSTOP OR FLEXIBLE BOOT)
- CONTRACTOR TO TAKE APPROPRIATE MEASURES TO PROTECT THE DEVICE FROM CONSTRUCTION-RELATED EROSION RUNOFF.
- DEVICE ACTIVATION, BY CONTRACTOR, SHALL OCCUR ONLY AFTER SITE HAS BEEN STABILIZED AND THE STORMCEPTOR UNIT IS CLEAN AND FREE OF DEBRIS.

I:\MIRLUM\PRODUCTS\STORMCEPTOR EF80 DRAWINGS & DETAIL\STANDARD DETAIL\SEF8-DETAIL.DWG 4/12/2018 10:58 AM

FOR SITE SPECIFIC DRAWINGS PLEASE CONTACT YOUR LOCAL STORMCEPTOR REPRESENTATIVE. SITE SPECIFIC DRAWINGS ARE BASED ON THE BEST AVAILABLE INFORMATION AT THE TIME. SOME FIELD REVISIONS TO THE SYSTEM LOCATION OR CONNECTION PIPING MAY BE NECESSARY BASED ON AVAILABLE SPACE OR SITE CONFIGURATION REVISIONS. ELEVATIONS SHOULD BE MAINTAINED EXCEPT WHERE NOTED ON BYPASS STRUCTURE (IF REQUIRED).

STANDARD DETAIL NOT FOR CONSTRUCTION

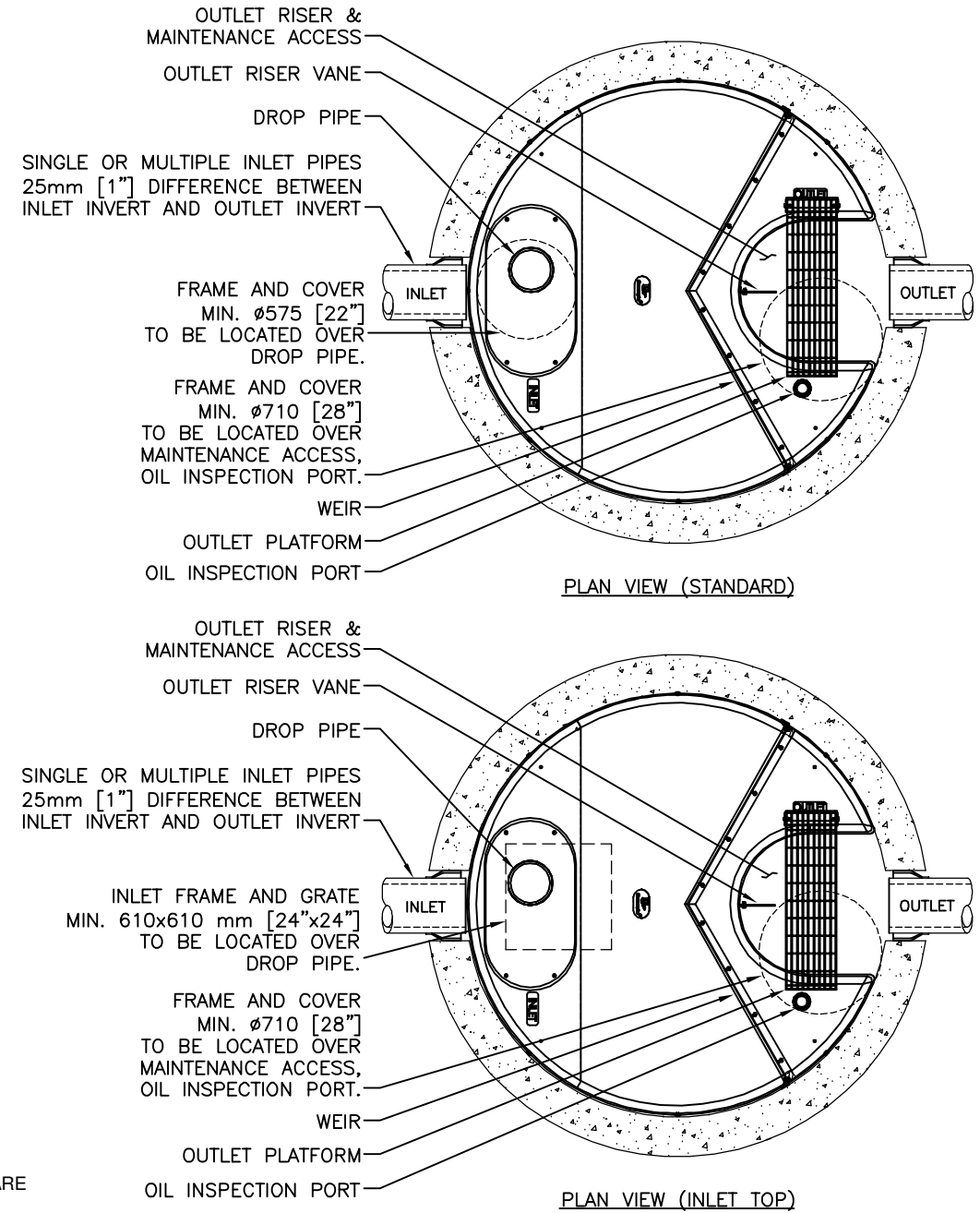

SITE SPECIFIC DATA REQUIREMENTS					
STORMCEPTOR MODEL	EF8				
STRUCTURE ID	*				
WATER QUALITY FLOW RATE (L/s)	*				
PEAK FLOW RATE (L/s)	*				
RETURN PERIOD OF PEAK FLOW (yrs)	*				
DRAINAGE AREA (HA)	*				
DRAINAGE AREA IMPERVIOUSNESS (%)	*				
PIPE DATA:	I.E.	MAT'L	DIA	SLOPE %	HGL
INLET #1	*	*	*	*	*
INLET #2	*	*	*	*	*
OUTLET	*	*	*	*	*

* PER ENGINEER OF RECORD

Stormceptor® EF

imbrium

407 FAIRVIEW DRIVE, WHITBY, ON L1N 3J9
 TEL: 800-385-4801 CA: 416-960-9600 INTL: +1-416-960-9600
 THE STORMCEPTOR SYSTEM IS THE PROPERTY OF IMBRIUM SYSTEMS (CANADA) LTD.
 ALL RIGHTS RESERVED. THIS DRAWING IS THE PROPERTY OF IMBRIUM SYSTEMS (CANADA) LTD.
 IT IS NOT TO BE REPRODUCED OR TRANSMITTED IN ANY FORM OR BY ANY MEANS, ELECTRONIC OR MECHANICAL, WITHOUT THE WRITTEN PERMISSION OF IMBRIUM SYSTEMS (CANADA) LTD.

DATE	REVISION DESCRIPTION	BY
5/26/2017 <td>INITIAL RELEASE <td>JSK </td></td>	INITIAL RELEASE <td>JSK </td>	JSK
6/8/18 <td>OUTLET PLATFORM <td>JSK </td></td>	OUTLET PLATFORM <td>JSK </td>	JSK

MARK	DATE	REVISION DESCRIPTION
1	5/26/17	INITIAL RELEASE
0		

SCALE = NTS

This drawing and information shown on this drawing is provided as a service to the project owner, engineer and contractor by Imbrium Systems (Canada) Ltd. Neither the drawing, nor any part thereof, may be reproduced or transmitted in any form or by any means, electronic or mechanical, including photocopying, recording, or by any information storage and retrieval system, without the prior written consent of Imbrium. Failure to comply with the above conditions may result in Imbrium Systems (Canada) Ltd. being held liable for any loss or damage, including any consequential or incidental loss or damage, arising from the use of this drawing. Imbrium Systems (Canada) Ltd. does not assume any liability for design or construction errors or omissions or for any information supplied by others.

C.4 BACKGROUND EXCERPTS





Mary Dickinson
City of Ottawa
Via email: mary.dickinson@ottawa.ca

Subject: Pre-Consultation: Meeting Feedback
Proposed ZBLA and POS Application – 1770 Heatherington Road

Please find below information regarding next steps as well as consolidated comments from the above-noted pre-consultation meeting held on September 21, 2023.

Pre-Consultation Preliminary Assessment

1 <input type="checkbox"/>	2 <input type="checkbox"/>	3 <input checked="" type="checkbox"/>	4 <input type="checkbox"/>	5 <input type="checkbox"/>
----------------------------	----------------------------	---------------------------------------	----------------------------	----------------------------

One (1) indicates that considerable major revisions are required while five (5) suggests that the proposal appears to meet the City’s key land use policies and guidelines. This assessment is purely advisory and does not consider technical aspects of the proposal or in any way guarantee application approval.

Next Steps

1. A review of the proposal and materials submitted for the above-noted pre-consultation has been undertaken. Please proceed to complete a Phase 3 Pre-consultation Application Form and submit it together with the necessary studies and/or plans to planningcirculations@ottawa.ca.
2. In your subsequent pre-consultation submission, please ensure that all comments or issues detailed herein are addressed. A detailed cover letter stating how each issue has been addressed must be included with the submission materials. Please coordinate the numbering of your responses within the cover letter with the comment number(s) herein.
3. Please note, if your development proposal changes significantly in scope, design, or density before the Phase 3 pre-consultation, you may be required to complete or repeat the Phase 2 pre-consultation process.

Supporting Information and Material Requirements

1. The attached Study and Plan Identification List outlines the information and material that has been identified, during this phase of pre-consultation, as either required (R) or advised (A) as part of a future complete application submission.
 - a. The required plans and studies must meet the City’s Terms of Reference (ToR) and/or Guidelines, as available on Ottawa.ca. These ToR and Guidelines outline the specific requirements that must be met for each plan or study to be deemed adequate.
 - b. The Adequacy of Public Services Report shall include details related to the proposed stormwater management plan for the subdivision. The stormwater management plan shall be detailed enough to confirm the stormwater management criteria provided by the City can be achieved.

- c. The Site Servicing Plan and Grading Plan requested can be “conceptual” to support the rezoning application.

Consultation with Technical Agencies

1. You are encouraged to consult with technical agencies early in the development process and throughout the development of your project concept. A list of technical agencies and their contact information is enclosed.

Planning (Justin Grift)

Proposal:

New residential development with new local public road, parkland and a mix of low-rise apartments, stacked townhouses, townhouses and semi-detached dwellings.

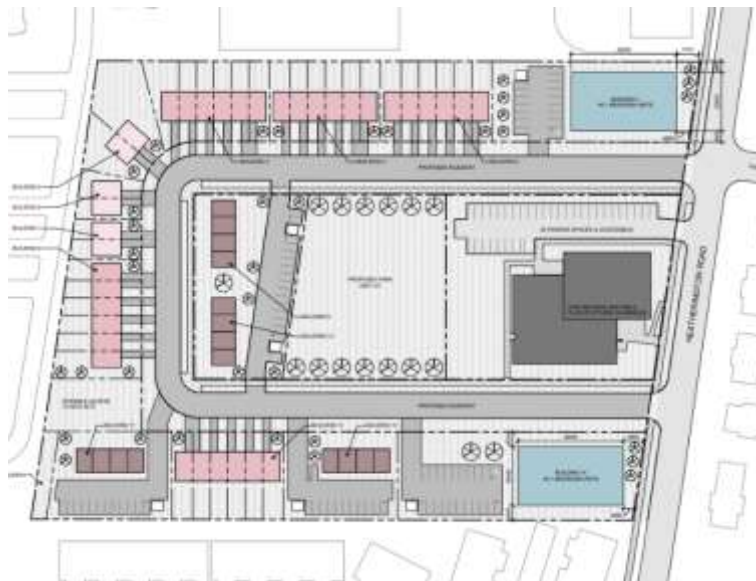

Comments:

1. Policies and provisions
 - a. The property is within the Outer Urban Transect and designated Neighbourhood in the Official Plan.
 - b. Currently zoned IG1 [2663], proposing R4M with Exception
 - i. Please explain why selecting Subzone M in Planning Rationale
 - ii. When reviewing for additional relief for the ZBLA, keep in mind the site falls within the Greenbelt and the Infill Provisions in Section 139 of ZBL apply, particularly minimum aggregated landscaped areas and maximum driveway widths.
2. Landscape requirements
 - a. A landscape plan is required prior to early servicing.

3. Parking requirements
 - a. As discussed, proposing to reduce parking to the amount required in Area B as opposed to Area C in the Zoning By-law. Please address the proposed reduction in Planning Rationale.
4. In the Preliminary Construction Management Plan, please indicate how/whether existing bus stop along Heatherington will be impacted by future street.
5. Draft Approval for the Plan of Subdivision will need to be approved before the Zoning Amendment is brought in as a Phase 3 pre-consultation, as per the new Bill 109 process.

Feel free to contact Justin Grift, Planner, for follow-up questions at justin.grift@ottawa.ca.

Urban Design (Nader Kadri)

I am providing similar comments to the comments that were provided last year, as well as an updated Design Brief Terms of Reference. In summary, I think the proposal can be bolstered to include additional multi-unit housing types, and that the site needs to have stronger consideration for how it might stitch into adjacent development sites in the future.

Comments:

1. An Urban Design Brief that follows the provided Terms of Reference is required upon submission of the application(s).
2. Provide cross sections for proposed new public road. If only one sidewalk is provided, it is worth discussing/comparing the benefits of the location of the sidewalk on either side of the loop.
3. We appreciate that the proposed interior public road aligns with Fairlea Crescent. Also appreciate the efforts made on the south-west corner of the site to connect to the surrounding community (potential future road connecting to MTO site and the pathway). Please consider revising the scheme to improve the park frontage and to add additional connections (example below):

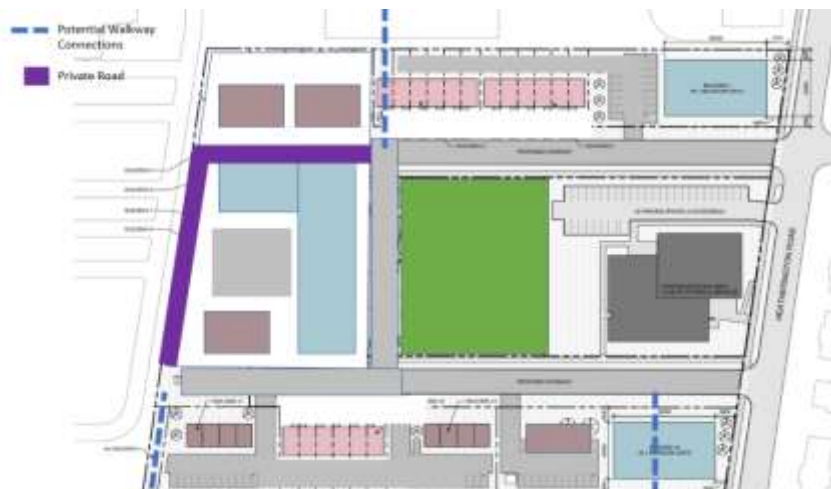

4. Consider introducing more multi-unit housing options within a four storey built form.

5. Ground floor activation required for all buildings. Consider townhomes at-grade for all apartment buildings.
6. All parking areas should be located at the rear so that they are not visible from the public realm.
7. Consolidate parking entrances to limit the number of curb cuts. Parking for townhome units should also be accessed via a rear lane:



8. Consider how the previous salt-storage use on-site may affect sustainable landscaping on-site. Consult with the remediation group to determine what can be planted, and how (replacing the soils? Will the salt leach?). If large mature trees are unable to grow, the architecture of the buildings becomes that much more important and visible. If landscaping is a challenge due to the salt levels, consider other ways to provide landscaping on-site.
9. Consider safe and accessible areas for bike parking.
10. Consider how lighting will be used on site and possible CPTED concerns. Will there be lighting installed on the private road/park?
11. Explore ways to minimize the impact of all waste, loading and parking areas on the public realm experience.
12. As the design develops further, strive toward creating variation amongst the building designs. It is good to have a theme/consistent elements throughout the building designs; however, creating variation in the individual building/unit designs will be critical in breaking-up the appearance of massing and in making it a visually interesting and successful built form. The building design variation does not necessarily have to be done with expensive fenestration, just a creative approach to the design details.

Feel free to contact Nader Kadri, Urban Design Planner, at nader.kadri@ottawa.ca for follow-up questions.

Engineering (Tyler Cassidy)

Comments:

6. The Stormwater Management Criteria, for the subject site, is to be based on the following:
- b. The subject site is located within the Sawmill Creek Subwatershed area. The Sawmill Creek Subwatershed Study (2003) should be referred to for stormwater management criteria. Per the subwatershed study, peak flows from development sites must be controlled to the 2-year return period event, up to and including the 100-year event.
 - c. 2-yr storm event using the IDF information derived from the Meteorological Services of Canada rainfall data, taken from the MacDonald Cartier Airport, collected 1966 to 1997.
 - d. Quality Control requirements are to be provided by Rideau Valley Conservation Authority (RVCA). On a previous Site Plan on this lot, the RVCA has stated that "while the site appears to be within the serviced area identified for the Sawmill Creek SWMF, the flow path for stormwater appears to bypass the wetland facility. Therefore, unless it can be confirmed that the site is serviced by the SWMF, then the site would require onsite water quality control of 80% TSS".
 - e. The pre-development runoff coefficient or a maximum equivalent 'C' of 0.5, whichever is less (§ 8.3.7.3).
 - f. A calculated time of concentration (Cannot be less than 10 minutes).
 - g. Flows to the storm sewer in excess of the 2-year storm release rate, up to and including the 100-year storm event, must be detained on site.
 - h. Please discuss with the City's Project Manager if Low Impact Development (LID) strategies are proposed for the site. Further information on LID's can be found in the City's Low Impact Development Technical Guidance Report.

Deep Services (Storm, Sanitary & Water Supply)



- a. Connections (Heatherington Road):
 - a. Existing 675 mm dia. STM (Concrete)
 - b. Existing 203 mm dia. Watermain (Cast Iron)
 - c. Existing 375 mm dia. SAN (Concrete)
- b. Connections to trunk sewers and easement sewers are typically not permitted.
- c. A monitoring maintenance hole shall be provided and should be located in an accessible location on private property near the property line (ie. Not in a parking area).
- d. Sewer connections to be made above the springline of the sewermain as per:
 - i. Std Dwg S11.1 for flexible main sewers – connections made using approved tee or wye fittings.
 - ii. Std Dwg S11 (For rigid main sewers) – lateral must be less than 50% the diameter of the sewermain,
 - iii. Std Dwg S11.2 (for rigid main sewers using bell end insert method) – for larger diameter laterals where manufactured inserts are not available; lateral must be less than 50% the diameter of the sewermain,

- iv. Connections to manholes permitted when the connection is to rigid main sewers where the lateral exceeds 50% the diameter of the sewermain. – Connect obvert to obvert with the outlet pipe unless pipes are a similar size.
 - v. No submerged outlet connections.
 7. Water Boundary condition requests must include the location of the service (map or plan with connection location(s) indicated) and the expected loads required by the proposed development, including calculations. Please provide the following information:
 - a. Location of service
 - b. Type of development and the amount of fire flow required (as per FUS).
 - c. Average daily demand: ___ l/s.
 - d. Maximum daily demand: ___ l/s.
 - e. Maximum hourly daily demand: ___ l/s.
 8. Water supply redundancy will be required for more than 50 m³/day water demand. Provide watermain looped connection or with isolation valve to meet this requirement. Based on the proposed scope of the project, it is unlikely that this criteria will be exceeded.
 9. An MECP Environmental Compliance Approval Municipal/Private Sewage Works will be required for the proposed development. Please contact the Ministry of the Environment, Conservation and Parks, Ottawa District Office to arrange a pre-submission consultation:
 - a. Charlie Primeau at (613) 521-3450, ext. 251 or Charlie.Primeau@ontario.ca
- Note that Draft Approval is required before an application is sent to the MECP.
10. Please note that there are known water supply constraints in this area. Please coordinate the boundary conditions early on to identify any such constraints.

Feel free to contact Tyler Cassidy, P.Eng., Infrastructure Project Manager, for follow-up questions at tyler.cassidy@ottawa.ca.

Transportation (Mike Giampa)

Comments:

11. A TIA is required for the rezoning; proceed to Step 2 (scoping).
12. The local roads should be designed to 30 kph.
13. Heaterington Road has an approved RMA (Feb 2021) for sidewalks, traffic calming and bike lanes.
14. Heaterington does not have a protected right of way.

Noise

15. A road noise study will be required for the Plan of Subdivision.

Feel free to contact the Transportation Project Manager, Mike Giampa, at Mike.Giampa@ottawa.ca for follow-up questions.

Trees (Mark Richardson)

Comments:

16. The TCR should be straight forward - for more information on the process or help with TCR requirements, contact Mark Richardson mark.richardson@ottawa.ca. Staff were on site and did not find butternut trees.

17. A Tree Conservation Report (TCR) is required.

18. A tree permit is required.

19. The TCR needs to include Plan/Map 2; map/plan 1 is optional:

a. Plan/Map 1 - show existing conditions with tree cover information

b. Plan/Map 2 - show proposed development with tree cover information

20. The TCR must document the trees on site, as well as off-site trees if the CRZ extends into the developed area, by species, diameter and health condition. Averages along with a general description can be used.

21. Please identify trees by ownership – private onsite, private on adjoining site, city owned, co-owned (trees on a property line)

22. If trees are to be removed, the TCR must clearly show where they are, and document the reason they cannot be retained

23. All retained trees must be shown, and all retained trees within the area impacted by the development process must be protected as per City guidelines available at ottawa.ca

Planning Forester LP tree planting requirements:

24. Please ensure any retained trees are shown on the LP

25. Minimum Setbacks

a. Maintain 1.5m from sidewalk or MUP/cycle track or water service laterals.

b. Maintain 2.5m from curb

c. Coniferous species require a minimum 4.5m setback from curb, sidewalk or MUP/cycle track/pathway.

26. Maintain 7.5m between large growing trees, and 4m between small growing trees. Park or open space planting should consider 10m spacing, except where otherwise approved in naturalization / afforestation areas. Adhere to Ottawa Hydro's planting guidelines (species and setbacks) when planting around overhead primary conductors.
27. Tree specifications
 - a. Minimum stock size: 50mm tree caliper for deciduous, 200cm height for coniferous.
 - b. Maximize the use of large deciduous species wherever possible to maximize future canopy coverage
 - c. Tree planting on city property shall be in accordance with the City of Ottawa's Tree Planting Specification; and if possible include watering and warranty as described in the specification.
28. No root barriers, dead-man anchor systems, or planters are permitted.
29. No tree stakes unless necessary (and only 1 on the prevailing winds side of the tree)
30. If there are hard surface plantings, a planting detail must be provided
31. Curb style planters are highly recommended over other planters
32. No grates are to be used and if guards are required, City of Ottawa standard (which can be provided) shall be used.
33. Please demonstrate as per the Landscape Plan Terms of Reference that the available soil volumes for new plantings will meet or exceed what is recommended.
 - a. If Sensitive Marine Clay are found - Please follow the City's 2017 Tree Planting in Sensitive Marine Clay guidelines
34. The City requests that consideration be given to planting native species where ever there is a high probability of survival to maturity.
35. Efforts shall be made to provide as much future canopy cover as possible at a site level, through tree planting and tree retention. The Landscape Plan shall show/document that the proposed tree planting and retention will contribute to the City's overall canopy cover over time. Please provide a projection of the future canopy cover for the site to 40 years.

Feel free to contact Mark Richardson, Forester, at mark.richardson@ottawa.ca for follow-up questions.

Environment (Matthew Hayley)

36. As I discussed in the meeting, since the only trigger for an EIS is the potential species at risk which is a butternut tree, I recommend that this be addressed in the TCR instead of contracting a separate consultant to complete an EIS. This is addressed in the TOR for tree conservation reports but not all TCR authors consider butternut trees, so this will need to be identified in the request.

37. Bird-Safe Design Guidelines Bird-safe development guidelines, the buildings are low rise, so the guidelines are not required however there are some guidelines that should be reviewed as they may improve the site from a landscape and bird friendly perspective. If any of the buildings are above 4 storeys, then the bird-safe design guidelines will apply, this will be considered at site plan.
38. Climate Change - Please add features that reduce the urban heat island effect (see OP 10.3.3) produced by the parking lot and a building footprint. For example, this impact can be reduced by adding large canopy trees, green roofs or vegetation walls, or constructing the parking lot or building differently.
39. The site layout as indicated the be plan presented at preconsult could be improved through the provisions of more trees. Please consider pairing driveways in the townhomes to allow for trees between each driveway. As discussed, the 18 m ROW has space for trees and the zoning setbacks selected should ensure we have street trees.

Feel free to contact Matthew Hayley, Environmental Planner, at matthew@hayley@ottawa.ca for follow-up questions.

Parkland (Phil Castro)

Comments:

40. Comments are forthcoming.

Other

41. The High Performance Development Standard (HPDS) is a collection of voluntary and required standards that raise the performance of new building projects to achieve sustainable and resilient design. The HPDS was passed by Council on April 13, 2022.
 - a. At this time, the HPDS is not in effect and Council has referred the 2023 HPDS Update Report back to staff with direction to bring forward an updated report to Committee with recommendations for revised phasing timelines, resource requirements and associated amendments to the Site Plan Control By-law by no later than Q1 2024.
 - b. Please refer to the HPDS information attached and ottawa.ca/HPDS for more information.

Should there be any questions, please do not hesitate to contact myself or the contact identified for the above areas / disciplines.

Sincerely,

Justin Grift

cc.

Mélanie Gervais,
Nader Kadri
Tyler Cassidy



Mike Giampa
Mark Richardson
Matthew Hayley

9 Guidelines for Development in the Watershed

9.1 Overview

The 1994 Sawmill Creek Watershed Study report included a set of guidelines regarding impact assessments for land development proposals in the Sawmill Creek watershed. These guidelines have been updated based on updated technical analyses that are described below. Complete details are given in Appendices B & C. An updated version of the 1994 development impact assessment guidelines for water, biological and social impacts is given in Appendix F.

A number of the guidelines for new development relate to stormwater management to deal with potential impacts on water quality, creek baseflow maintenance, downstream flooding and watercourse erosion.

As part of the current project, analyses have been carried out to examine the potential impact of the expected future development with respect to these water management concerns.

This section of the report outlines the results of these analyzes and provides recommendations regarding stormwater management in new development areas.

This section also includes updated development guidelines for protecting aquatic and terrestrial resources.

9.2 WMS Requirement for Site-Level Water Management

The WMS was in part based on the need to maintain recharge to the shallow aquifer system that was then believed to be the primary source for baseflow along the creek. The interpretation set out in the 1994 study was that, in particular, the shallow water table in the southern headwaters portion of the watershed was important for maintaining baseflow. Therefore any new land development in that portion of the watershed should be based on maintaining recharge on each development property. It was recommended that the land development approval process recognize this need and ensure appropriate site drainage design. It was recommended that recharge be maintained on a site-by-site basis to as much as possible maintain the spatial distribution of recharge, given the relatively variable surficial geology within the watershed.

It was also recommended that development site designs be based on:

- minimizing surface runoff volumes
- control pollutant loads discharged by site drainage

- ensuring that there is no downstream increase in peak flows or water levels for return periods of 2 years to 100 years, at any downstream location along Sawmill Creek or its tributaries
- ensuring that there is no increase in downstream watercourse erosion by ensuring no increase in the erosive power ("erosive impulse") of the flow regime at any downstream location along the creek or its tributaries
- maintaining pre-development water balance on a site-by-site basis, and ensuring maintenance of annual and seasonal water table recharge

Current Status

The recommendations from the earlier report have been used by agencies to guide the review of development applications in the watershed. The technical basis for the development guidelines has been reviewed, in order to update and enhance the guidelines. The various issues and requirements related to water management are presented below, followed by presentation of the updated guidelines.

9.3 Creek Baseflow Protection

Updated Interpretation of Local Hydrogeology and Baseflow Sources

Investigations carried as part of this update project have included:

- Baseflow measurements at various locations along the creek in May, June and August 2002, as a means of further investigating creek baseflow sources and locations or creek reaches in which noticeable baseflow increases occur.
- Completion of a Hydrogeological Overview study by Morey Houle Chevrier Engineering Limited (MHC) that has included review of available information on watershed geology, water table conditions and baseflow measurements in order to provide an updated and more detailed assessment of watershed hydrogeology and likely sources of baseflow.

The outcome of the above investigations is summarized as follows:

- There has been general confirmation that the shallow water-table system provides a primary source of creek baseflow in the southern portion of the watershed. For example, surficial sand deposits over clay in the area of the Airport are very likely the primary source of baseflow in the Lester Road area.
- Further downstream, drainage of surficial sand deposits is being channeled to the creek by building foundations drains in some areas (e.g. near Hunt Club Rd and Albion Road).
- Also, the Cahill tributary appears to be fed by gravity drainage of surficial deposits, with there being a notable increase related to roadway subdrainage around the Airport

Table 17 Site specific techniques for enhancing recharge at the lot level in Sawmill Creek subwatershed

Soil	Groundwater Levels	Foundations	SWM	Infiltration	Site Design
Shallow deposits of sand/silty sand	Generally <u>above</u> depth of foundations and services. Levels decrease with construction drainage and conventional perimeter drainage.	Commercial/industrial and Institutional - Shallow foundations. Frost protection achieved using earth cover and extruded polystyrene insulation. Residential – Foundations above groundwater level by adding fill and/or using a reduced depth for the basements. Grade raise filling likely required to achieve drainage in areas of shallow groundwater depth.	Roof drainage to pervious areas. Additional lot level infiltration techniques required where soil conditions permit. Sheet drain impervious areas, roofs, road subdrains, and sumps to: <ul style="list-style-type: none"> ▪ Reduced lot grading to less than 2 percent beyond 4 to 6 m from the foundation ▪ Scarification of native soil prior to placing earth fill and topsoil ▪ Shallow infiltration ponds and basins ▪ Infiltration pits and trenches ▪ Grassed swales or shallow depressions ▪ Shallow pervious pipe systems ▪ Bio-retention areas. 	Variable percolation rates. Detailed investigations required for SWM measures. Percolation rates may range from about 15 to 100 mm/hour for silty sand and clean uniform sand, respectively, which are suitable for infiltration. For finer materials (e.g. sandy silt or clays), percolation times may be less, and the range of applicable infiltration systems may be limited. Pretreatment may be required to reduce clogging and maintenance requirements.	Minimize impervious areas Provide sump pumps, if required, to discharge foundation drains to infiltration pits/trenches/basins, swales, etc. Use relatively permeable sandy fill material as grade raise fill within landscaped areas. Mitigate leakage at sewers & manholes installed below the pre-development groundwater level. Seepage barriers along service trenches to prevent groundwater lowering due to “French drain effects”. Implement cluster development / site layout to permit landscape-based SWM solutions.
Glacio-fluvial sand and gravel	Generally <u>below</u> depth of foundations and services. Minimal groundwater level impacts from construction and foundations.	Standard depths (1.5 to 1.8 m below finished ground surface)	See above	Percolation rate for native sand and gravel could be 50 to 100 minutes per centimeter, which is suitable for infiltration.	See above

Appendix D – GEOTECHNICAL INVESTIGATION

D.1 GEOTECHNICAL REPORT EXCERPTS



Executive Summary

Introduction

EXP Services Inc. (EXP) is pleased to present the results of the geotechnical investigation completed for the proposed residential subdivision development to be located at 1770 Heatherington Road, in Ottawa, Ontario (Figure 1). Terms and conditions of this assignment were outlined in EXP's two (2) proposals dated April 18, 2023 and March 1, 2024 and is under EXP's standing offer agreement with the City of Ottawa SOA 30820-92500-S01 Category 5A and 5B. Authorization to proceed with this work was provided by City of Ottawa PO Number PO 0451055165.

It is noted that EXP completed Phase One and Two Environmental Site Assessments (ESAs), a Site-Specific Risk Assessment (SSRA) and a Soil Characterization of the two (2) soil berms on site under separate assignments for this project with the City of Ottawa.

Proposed Development

The site consists of a 2.7-hectare former City of Ottawa works yard that is currently vacant. It is understood that the site was formerly occupied by structures including office trailers, quonset huts, an above ground (liquid) calcium chloride storage tank, salt storage facilities, a maintenance garage and a storage shed. The property was also used as a snow dump site. These former structures have been removed from the site. It is not known if below grade floor slabs, foundation walls and foundations of the former buildings/structures and former underground services were also excavated and removed from the site.

The draft functional grading plan, Drawing No. GP-1, dated November 15, 2023 (Revision No. 1), prepared by Stantec Consulting Ltd. (Stantec) indicates the site is divided into fifteen (15) building blocks, namely Blocks 1 to 15. The residential development will consist of two low-rise apartment buildings (2 to 3-storeys) at Blocks 1 and 14 and townhouse-type buildings at the remaining blocks. An outdoor park is proposed at Block 16. The buildings will all have one (1) basement level. The site will be serviced by municipal services, there will be outdoor paved parking lots and a horizontal U-shaped access road within the site leading at two (2) locations to Heatherington Road. Stantec indicated that the proposed elevation of the underside of the footing (USF) for the buildings will be 1.8 m below the design elevation of the proposed centreline of the U-shaped access road and that the site grade raise in the blocks will be 1.0 m above the proposed design elevations of the centreline of the new U-shaped access road.

The draft functional site servicing plan, Drawing No. SSP-1, dated November 15, 2023 (Revision No.1) and prepared by Stantec indicates the pipe obvert for 200 mm to 675 mm diameter underground service pipes ranges from Elevation 85.32 m to Elevation 84.27 m, approximately 3.0 m to 4.0 m below existing grade.

Borehole Fieldwork Program

The fieldwork for this geotechnical investigation was undertaken in two (2) phases and consists of fourteen (14) boreholes and six (6) static cone penetration tests (piezocone penetration tests, CPTs). The first phase was undertaken from November 21 to December 12, 2023 and consists of nine (9) boreholes (Borehole Nos. 23-1 to 23-9) advanced to auger refusal and termination depths ranging from 5.6 m to 9.9 m below existing grade. The second phase was undertaken from March 24 to 26, 2024 and consists of five (5) boreholes (Borehole Nos. 24-10 and 24-12 to 24-15) and six (6) piezocone penetration tests (CPTu 1, CPTu 2, SCPTu 3, CPTu 4, SCPTu 5 and CPT 6). Borehole No. 24-11 was not drilled. The boreholes extended to auger and casing refusal depths of 5.9 m to 6.9 m below existing grade. The piezocone penetration tests (CPTs) extended to 4.5 m to 6.2 m below existing grade. The borehole and cone penetration test fieldwork was supervised on a full-time basis.

Subsurface Conditions

The information from the boreholes indicates the subsurface conditions at the site consist of surficial topsoil and reclaimed asphalt pavement (RAP) underlain by fill that extends to depths of 0.3 to 3.2 m (Elevation 87.2 m to Elevation 84.3 m) further underlain by firm to very stiff silty clay to depths ranging from 2.2 m to 4.5 m (Elevation 85.7 m to Elevation 82.7 m), very loose to very dense glacial till that extends to depths of 5.5 m to 6.2 m (Elevation 82.3 m to Elevation 80.3 m) followed by shale bedrock contacted at 5.5 m to 6.2 m depths (Elevation 82.3 m to Elevation 80.3 m). It is noteworthy to mention that 75 mm to 200 mm thick buried organic clayey silt layers are present in some boreholes. Based on the recent April 17, 2024 set of measurements, the groundwater level ranges from 1.1 m to 2.7 m depths (Elevation 86.4 m to Elevation 84.6 m).

Geotechnical Engineering Comments and Recommendations

Liquefaction analysis was conducted using the data collected from the boreholes and the piezocone penetration tests (CPTs). The analysis indicates the silty clay above the glacial till is not liquefiable during a seismic event. The analysis indicates the very loose to compact zone of the glacial till is liquefiable during a seismic event with an average factor of safety of less than 1.0. The glacial till is liquefiable in in Blocks 3,8,10,12,13 and 15. The glacial till is not liquefiable in Blocks 1,2,6 and 14. Post-liquefaction settlements were calculated to range from 56 mm to 168 mm. The approximate area of the liquefiable glacial till on site is shown in Figure 3 of the attached report. It is not known if the subsurface soils in Blocks 4,5,7 and 9 are liquefiable. However, since these blocks are located between blocks where the glacial till has been determined to be liquefiable, Blocks 4,5,7 and 9 along with Block 6 are included within the approximate area of the liquefiable glacial till shown in Figure 3.

Ground improvement at the site will be required to address the presence of the liquefiable soils to ensure performance of the buildings and basement floor slabs (lowest slabs) during a seismic event. A local specialized contractor was contacted and confirmed that the site can be improved to address the liquefiable soil and to possibly improve the bearing pressures recommended for the footings to support the proposed buildings. The contractor indicated that controlled modulus columns (CMCs) is the most appropriate method to improve the ground at the site.

Since liquefiable soils have been established on site, Table 4.1.8.4.A of the 2012 OBC (as amended January 2022) indicates that for liquefiable soils, the site classification for seismic response is **Class F**. However, for the determination of the site classification for seismic response, the OBC permits that the presence of liquefiable soils can be ignored, provided the proposed buildings will be designed for a fundamental period of vibration equal to or less than 0.5 seconds.

For the case where the liquefiable soils are ignored by designing the proposed buildings for a fundamental period of vibration equal to or less than 0.5 seconds or are addressed by ground improvement, data from SCPTu 3 and SCPTu 5 was used to determine the site classification for seismic response. SCPTu 3 and SCPTu 5 measured the shear wave velocity within the silty clay and glacial till. The average shear wave velocity was determined to be 125 m/s. Based on an assumed shear wave velocity for the underlying shale bedrock of 1000 m/s from Table 4.1.8.4.A of the 2012 Ontario Building Code (as amended January 1,2022), the weighted average of the shear wave velocity for a 30 m depth is 1164 m/s. Based on Table 4.1.8.4.A of the 2012 OBC (as amended January 2022), for a shear wave velocity of 1164 m/s and that the underside of the footings will be greater than 3.0 m from the bedrock, the classification of the site for seismic response is **Class C**.

It is EXP's opinion that consideration should be strongly given to improving the ground at the site to address the liquefaction issue to ensure the long-term satisfactory performance of the proposed buildings and basement floor slabs (lowest floor slab) during a seismic event, since the calculated post-liquefaction settlements may render the proposed buildings non-operational. The ground improvement may also increase or improve the SLS and factored ULS values recommended in this report for the proposed site grade raise.

Based on information and drawings from Stantec, the grade raise at the blocks and along the subdivision access road is anticipated to range from approximately 0.5 m to 2.5 m. Along the proposed subdivision road, there are some cut areas. The proposed site grade raise indicated for each block and along the proposed subdivision access road are considered acceptable from a geotechnical perspective. It is recommended that should the magnitude of the site grade raise change and be different than indicated in this report for the blocks and access road, EXP should be contacted to review the acceptability of the site grade raise.

For the blocks located within the approximate area of the liquefiable soil shown in Figure 3 of the attached report, if the post-liquefaction settlements of 56 mm to 168 mm are acceptable and can be tolerated by the building foundations and slab-on-grade, the proposed buildings may be supported by spread and strip footings designed to bear on the native silty clay, glacial till or engineered fill (constructed on the native soils) and the lowest floor slab (basement slab) may be designed as a slab-on-grade supported by the native soils. The footings founded at the underside of footing elevation (USF) determined from the Stantec drawing and indicated in Table IX may be designed for the bearing pressure at serviceability limit state (SLS) and factored geotechnical resistance at ultimate limit state (ULS) values indicated in Table IX of the attached report.

If the post-liquefaction settlements for the blocks located within the approximate area of the liquefiable soil shown in Figure 3 of the attached report are not acceptable and cannot be tolerated by the building foundations and slab-on-grade, ground improvement will be required. Once ground improvement has been completed, the proposed buildings may be supported by spread and strip footings founded on the improved soil and the lowest floor slab (basement slab) may be designed as a slab-on-grade supported by the improved soil. The footings founded at the USF indicated in Table IX may be designed for the SLS and

factored ULS values recommended in Table IX of the attached report. The total and differential settlements of the footings founded on the improved soil will be within normally tolerated limits of 25 mm total settlement and 19 mm differential settlement. It is possible that the SLS and factored ULS values along with the site grade raise can be increased as a result of the ground improvement.

For the two (2) proposed low-rise apartment buildings (2 to 3-storeys) to be located at Blocks 1 and 14 in a non-liquefiable area, the recommended SLS and factored ULS values for footings may not be sufficient to support the proposed buildings. In this case, the proposed buildings may be supported by pile foundations driven to practical refusal into the underlying shale bedrock and designed in end bearing. Caisson foundations are considered to be problematic due to the high groundwater level in combination with the very loose to compact zone of the silty sand glacial till below the groundwater level. Also, it is anticipated that with caissons, costs will be incurred from the removal and disposal of the soil spoil generated from each caisson. As an alternative to piles, even though Blocks 1 and 14 do not have liquefiable soils, if it is decided to use ground improvement at the other blocks (with liquefiable soils), ground improvement may also be considered for Blocks 1 and 14 to improve the SLS and factored ULS values sufficiently so that the proposed apartment buildings may be supported by footings founded on the improved soil.

The floor slab for the proposed buildings may be designed and constructed as a slab-on-grade placed on a 200 mm thick, 19 mm sized clear stone bed placed on a minimum 300 mm thick engineered fill pad set on the approved native subgrade constructed in accordance with Section 10.1 of the attached report. The clear stone will minimize the capillary rise of moisture from the sub-soil to the floor slab. Alternatively, the clear stone layer may be replaced with a 200 mm thick bed of OPSS Granular A overlain by a vapour barrier. Adequate saw cuts should be provided in the floor slabs to control cracking.

The proposed buildings will require a perimeter drainage system. The need for underfloor drainage system for the proposed buildings can be determined once the final design elevation of the basement floor is available.

The excavations may be undertaken by conventional heavy equipment capable of removing possible debris within the fill and cobbles and boulders within the glacial till.

Open cut excavations within the soils above the groundwater level are anticipated to be relatively straight forward. If ground improvement is selected to be used on this site, the excavation and dewatering comments and recommendations provided in this report may need to be updated.

All excavations must be undertaken in accordance with the Occupational Health and Safety Act (OHSA), Ontario Reg. 213/91. Based on the definitions provided in OHSA, the subsurface soils on site are considered to be Type 3 and as such must be cut back at 1H:1V from the bottom of the excavation. Within zones of seepage, the excavation side slopes are expected to slough and eventually stabilize at 2H:1V to 3H:1V from the bottom of the excavation. For excavations above the groundwater level or properly dewatered (refer to paragraph below), the installation of the municipal underground services may be undertaken within the confines of a prefabricated support system (trench box) designed and installed in accordance with OHSA.

Open cut excavations that extend into the silty sand to sandy silt glacial till below the groundwater level are anticipated to be more problematic and will require the lowering of the groundwater level prior to the start of excavation. It is anticipated that the base of the excavation in the silty sand to sandy silt glacial till and below the groundwater level may be susceptible to basal instability or base type failure in the form of piping or heave. To minimize the occurrence of base type failure, it is recommended that the groundwater level should be lowered by at least 1.0 m below the bottom of the excavation prior to the start of excavation. This may be achieved by installing deep sumps and pumping with high-capacity pumps. The dewatering contractor should review the subsurface conditions at the site and select the most appropriate method to lower the groundwater level.

Seepage of the surface and subsurface water into the excavations is anticipated. However, it should be possible to remove groundwater entering into the excavation by pumping from sumps. In areas of high infiltration or in areas where more permeable soil layers may exist, a higher seepage rate should be anticipated and will require high-capacity pumps to keep the excavation dry (possibly required to operate 24 hours a day, seven (7) days a week).

The pipe bedding for the installation of underground services including material specifications, thickness of cover material and compaction requirements should conform to City of Ottawa specifications, drawings and special provisions. The bedding and cover material should be compacted to a minimum of 95 percent standard Proctor maximum dry density (SPMDD).

It is anticipated that the majority of the material required for backfilling purposes in the interior and exterior of the proposed buildings and in the underground service trenches will need to be imported and should preferably conform to the material specifications indicated in the attached geotechnical report.

The above and other related considerations are discussed in greater detail in the main body of the attached geotechnical report.

1. Introduction

EXP Services Inc. (EXP) is pleased to present the results of the geotechnical investigation completed for the proposed residential subdivision development to be located at 1770 Heatherington Road, in Ottawa, Ontario (Figure 1). Terms and conditions of this assignment were outlined in EXP's two (2) proposals dated April 18, 2023 and March 1, 2024 and is under EXP's standing offer agreement with the City of Ottawa SOA 30820-92500-S01 Category 5A and 5B. Authorization to proceed with this work was provided by City of Ottawa PO Number PO 0451055165.

It is noted that EXP completed Phase One and Two Environmental Site Assessments (ESAs), as well as a Site-Specific Risk Assessment (SSRA) and a Soil Characterization of the two (2) soil berms on site under separate assignments for this project with the City of Ottawa.

The site consists of a 2.7-hectare former City of Ottawa works yard that is currently vacant. It is understood that the site was formerly occupied by structures including office trailers, quonset huts, an above ground (liquid) calcium chloride storage tank, salt storage facilities, a maintenance garage and storage shed. The property was also used as a snow dump site. These former structures have been removed from the site. It is not known if below grade floor slabs, foundation walls and foundations of the former buildings/structures and former underground services were also excavated and removed from the site.

The draft functional grading plan, Drawing No. GP-1, dated November 15, 2023 (Revision No. 1), prepared by Stantec Consulting Ltd. (Stantec) indicates the site is divided into fifteen (15) building blocks, namely Blocks 1 to 15. The residential development will consist of two low-rise apartment buildings (2 to 3-storeys) at Blocks 1 and 14 and townhouse-type block buildings at the remaining blocks. An outdoor park is proposed at Block 16. The buildings will all have one (1) basement level. The site will be serviced by municipal services, there will be outdoor paved parking lots and a horizontal U-shaped access road within the site leading at two (2) locations to Heatherington Road. Stantec indicated that the proposed design elevation of the underside of the footing (USF) for the buildings will be 1.8 m below the design elevation of the proposed centreline of the U-shaped access road and that the site grade raise in the blocks will be 1.0 m above the proposed design elevation of the centreline of the new U-shaped access road.

The draft functional site servicing plan, Drawing No. SSP-1, dated November 15, 2023 (Revision No.1) and prepared by Stantec indicates the pipe obvert for 200 mm to 675 mm diameter underground service pipes ranges from Elevation 85.32 m to Elevation 84.27 m; approximately 3.0 m to 4.0 m below existing grade.

The geotechnical investigation was undertaken to:

- a) Establish the subsurface soil and groundwater conditions at fourteen (14) boreholes and six (6) static cone penetration tests (piezocone penetration tests) located on the site,
- b) Classify the site for seismic site response in accordance with the requirements of the 2012 Ontario Building Code (as amended January 1, 2022) and assess the potential for liquefaction of the subsurface soils during a seismic event,
- c) Comment on grade-raise restrictions and provide site grading requirements,
- d) Make recommendations regarding the most suitable type of foundations, founding depth and bearing pressure at serviceability limit state (SLS) and factored geotechnical resistance at ultimate limit state (ULS) of the founding strata and comment on the anticipated total and differential settlements of the recommended foundation type,
- e) Provide comment regarding slab-on-grade construction and the requirement for perimeter and underfloor drainage systems,
- f) Comment on excavation conditions and de-watering requirements during construction,
- g) Provide pipe bedding requirements for underground services,
- h) Discuss backfilling requirements and suitability of on-site soils for backfilling purposes,
- i) Recommend pavement structure thicknesses for access road and parking lots,
- j) Comment on the corrosion potential of subsurface soils buried concrete and steel structures/members; and
- k) Provide comment on tree planting restrictions.

The comments and recommendations given in this report are based on the assumption that the above-described design concepts will proceed into construction. If changes are made either in the design phase or during construction, this office must be retained to review these modifications. The result of this review may be a modification of our recommendations, or it may require additional field or laboratory work to check whether the changes are acceptable from a geotechnical viewpoint.

2. Site Description

The site for the proposed residential development consists of a former City of Ottawa works yard that is partially surrounded by a chain link fence. The site is U shaped and is currently vacant, however, remnants of materials are stored on the site and include three (3) sand stockpiles, concrete, wooden pallets and lumber. The site is also occupied by two (2) soil berms located in the southwest and south portions of the site.

The ground surface of the site is covered with asphaltic concrete and fill. Tall shrubs and medium sized trees exist along the south portion of the site in addition to a gravel access road.

The site is bound to the north and the south by residential developments, to the west by a Drive Ontario testing facility and to the east by Heatherington Road. The Boys and Girls Club of Ottawa is located east of the site.

Based on the ground surface elevations at the boreholes, Elevation 88.01 m to Elevation 86.49 m, the ground surface gradually slopes down in an east and south direction.

Photographs of the site are shown in Appendix A.

3. Site Geology

3.1 Surficial Geology Map

The surficial geology was reviewed via the Google Earth applications published by the Ontario Ministry of Energy, Northern Development and Mines available via www.mndm.gov.on.ca/en/mines-and-minerals/applications/ogsearth/surficial-geology and was last modified on May 23, 2017. The map indicates the site is underlain by fine-textured glaciomarine deposits consisting of silt and clay with minor sand and gravel. Older alluvial deposits are present to the southeast of the site. The surficial deposits are shown in Image 1 below.

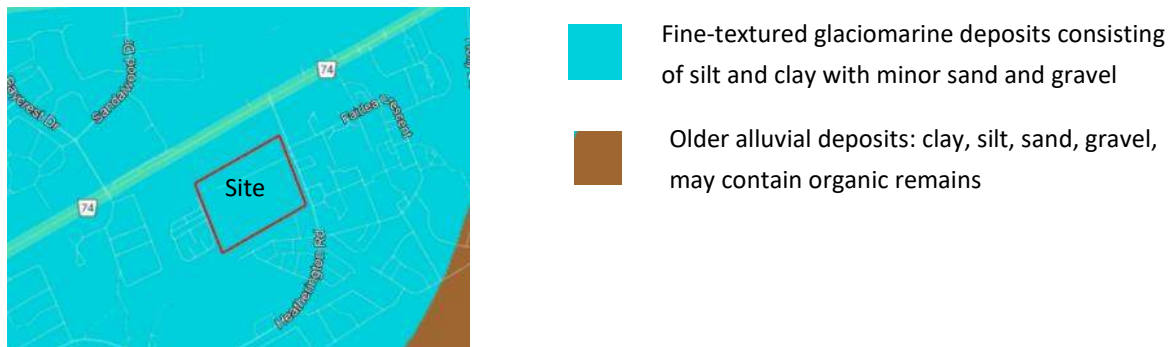

Image 1 – Surficial Geology

3.2 Bedrock Geology Map

The surficial geology was reviewed via the Google Earth applications published by the Ontario Ministry of Energy, Northern Development and Mines available via <http://www.geologyontario.mndm.gov.on.ca/mines/data/google/MRD219/geology/doc.kml> and publish in 2007. The map indicates the bedrock at the site consists of shale and limestone of the Carlsbad formation. The shale of the Carlsbad formation is an expansive type of shale. The bedrock geology is show in Image 2 below.



Image 2 – Bedrock Geology

4. Available Information

EXP (formerly Trow Associates Inc.) completed a geotechnical investigation at the site in 2008 and the results of the geotechnical investigation are provided in the report titled, *Preliminary Geotechnical Investigation, Proposed Residential Development, 1770 Heatherington Road, City of Ottawa, Ontario* dated October 17, 2008 (EXP Project No. OTGE00018293-JB). Borehole (BH)/Monitoring Well (MW) Nos. 08-10 to 08-17 from the 2008 geotechnical investigation are located on the current site and their locations are shown on the Test Hole Location Plan, Figure 2. The 2008 borehole logs are provided in Appendix B.

The geodetic ground surface elevations for some of the 2008 borehole/monitoring well locations were interpolated from the spot elevations provided on the 2023 draft functional grading plan by Stantec. Therefore, the ground surface elevations at these borehole locations are considered approximate.

5. Procedure

The fieldwork for this geotechnical investigation was undertaken in two (2) phases and consists of fourteen (14) boreholes and six (6) static cone penetration tests (piezocone penetration tests, CPTs). The first phase was undertaken from November 21 to December 12, 2023 and consists of nine (9) boreholes (Borehole Nos. 23-1 to 23-9) advanced to auger refusal and termination depths ranging from 5.6 m to 9.9 m below existing grade. The second phase was undertaken from March 24 to 26, 2024 and consists of five (5) boreholes (Borehole Nos. 24-10 and 24-12 to 24-15) and six (6) piezocone penetration tests (CPTu 1, CPTu 2, SCPTu 3, CPTu 4, SCPTu 5 and CPT 6). Borehole No. 24-11 was not drilled. The boreholes extended to auger and casing refusal depths of 5.9 m to 6.9 m below existing grade. The piezocone penetration tests (CPTs) extended to 4.5 m to 6.2 m below existing grade. The borehole and cone penetration test fieldwork was supervised on a full-time basis by EXP.

The locations and geodetic elevations of the boreholes and piezocone penetration tests were established by EXP and are shown on the test hole location plan, Figure 2. The ground surface elevation of Borehole No. 23-5 was interpolated from the spot elevation provided on the functional grading plan prepared by Stantec dated November 15, 2023 (Revision No. 1). Therefore, the ground surface elevation for Borehole No. 23-5 should be considered approximate.

The boreholes were drilled using a CME-45 track-mounted drill rig equipped with continuous flight hollow-stem auger equipment and rock coring capabilities. Below the augered depth of 1.5 m, the 2024 boreholes (Borehole Nos. 24-10 and 24-12 to 24-15) were advanced to casing refusal depths using casing and wash-boring technique and maintaining a head (column) of water in the casing. Standard penetration tests (SPTs) were performed in all the boreholes at 0.75 m to 1.5 m depth intervals and the soil samples retrieved by the split-spoon sampler. The undrained shear strength of the clayey soil was measured at selected depths by conducting penetrometer and in-situ vane tests. A relatively undisturbed thin-walled tube sample (Shelby tube) of the silty clay was collected at a selected depth in one (1) borehole. The bedrock was cored in three (3) boreholes using the N-size core barrel and conventional rock coring techniques. A field record of wash water return, colour of wash water and any sudden drops of the core barrel were kept during rock coring operations.

The subsurface soil conditions in each borehole were logged with each soil sample placed in labelled plastic bags. Similarly, the rock cores were visually examined, placed in core boxes, identified, and logged.

Nineteen (19 mm) diameter standpipes, thirty-two (32) mm diameter and fifty (50) mm diameter monitoring wells were installed in selected boreholes for long-term monitoring of the groundwater table and for groundwater sampling as part of the Phase Two ESA. The standpipes and monitoring wells were installed in accordance with EXP standard practice, and the installation configuration is documented on the respective borehole log. The boreholes were backfilled upon completion of drilling and installation of the standpipes and monitoring wells.

Static cone penetration tests (piezocone penetration tests, CPTs) were conducted at six (6) locations on the site. The piezocone penetration tests, CPTu 1, CPTu 2, CPTu 4 and CPTu 6, also measured the pore pressure. The piezocone penetration tests, SCPTu 3 and SCPTu 5 measured the shear wave velocity (seismic) in addition to pore pressure. The CPTs extended from the augered depths of 1.5 m and 1.6 m, locally a 3.0 m depth in CPTu 1, to termination depths of 4.5 m to 6.2 m below existing grade.

On completion of the borehole fieldwork, the soil samples and rock cores were transported to the EXP laboratory in Ottawa where they were examined by a geotechnical engineer and borehole logs prepared. The soils are classified by their main constituents in accordance with the Unified Soil Classification System (USCS) using the soil group name and symbol and by the modified Burmister soil classification method for the classification of the minor constituents of the soil using adjectives and modifiers such as trace and some (2006 Fourth Edition of the Canadian Foundation Engineering Manual (CFEM)).

The rock cores were visually examined by the geotechnical engineer and logged in accordance with Section 3.2 of the 2006 Canadian Foundation Engineering Manual (CFEM) Fourth Edition. Photographs were taken of the bedrock cores.

The laboratory testing program for the soil samples and rock core sections is summarized in Table I.

Table I: Summary of Laboratory Testing Program	
Type of Test	Number of Tests Completed
Soil Samples	
Moisture Content Determination	105
Unit Weight Determination	6
Grain Size Analysis	17
Atterberg Limit Determination	17
Corrosion Analysis (pH, sulphate, chloride and resistivity)	3
Bedrock Core Sections	
Unconfined Compressive Strength and Unit Weight Determination	3

6. Subsurface Conditions and Groundwater Levels

A detailed description of the subsurface conditions encountered in the boreholes is given on the attached Borehole Logs, Figures 4 to 17. The results of the piezocone penetration tests (CPTs) are shown in Appendix C.

The borehole logs and related information depict subsurface conditions only at the specific locations and at the times indicated. Subsurface conditions and water levels at other locations may differ from conditions at the locations where sampling was conducted. The passage of time also may result in changes in the conditions interpreted to exist at the locations where sampling was conducted.

Boreholes were drilled to provide representation of subsurface conditions as part of a geotechnical exploration program and are not intended to provide evidence of potential environmental conditions. Reference should be made to the EXP Phase One and Two Environmental Site Assessments (ESAs), the Site-Specific Risk Assessment (SSRA) and the Soil Characterization of the two (2) soil berms on site for potential environmental concerns for the subsurface conditions and soil berms at the site.

It should be noted that the soil boundaries indicated on the borehole logs are inferred from observations during drilling operations. These boundaries are intended to reflect approximate transition zones for the purpose of geotechnical design and should not be interpreted as exact planes of geological change. The “Notes on Sample Descriptions” preceding the borehole logs form an integral part of this report and should be read in conjunction with this report.

A review of the borehole logs indicates the following subsurface soil and bedrock conditions with depth and groundwater level measurements.

6.1 Topsoil

A 50 mm to 300 mm thick surficial topsoil layer was contacted in Borehole No. 23-7, 24-10, 24-12 and 24-15.

6.2 Reclaimed Asphalt Pavement (RAP)

A 75 mm thick surficial layer of reclaimed asphaltic pavement (RAP) was encountered in Borehole No. 23-1.

6.3 Fill

Fill was contacted beneath the surficial topsoil and RAP layer in Borehole Nos. 23-1, 24-10, 24-12 and 24-15, and surficially in the remaining boreholes. The fill extends to depths of 0.3 m to 3.2 m (Elevation 87.2 m to Elevation 84.3 m). The 3.2 m deep fill was contacted in Borehole No. 23-5. The fill ranges from crushed gravel to silty sand with gravel to silty sand to silty clay and contains topsoil and possible cobbles and boulders. The fill is in a very loose to very dense state. The moisture content of the fill ranges from 10 percent to 36 percent.

A mixture of silty sand fill and RAP was contacted beneath the surficial topsoil layer in Borehole No. 24-10 and extends to a 0.8 m depth (Elevation 86.9 m). Based on standard penetration test (SPT) N-value, the fill mixture is in a compact state. The moisture content of the fill mixture is 13 percent.

6.4 Buried Organic Clayey Silt

A buried organic clayey silt layer was encountered below the fill in Borehole Nos. 23-2, 23-7 to 23-9 and 24-10. The thickness of the organic clayey silt layer ranges from 75 mm to 200 mm.

6.5 Silty Clay

Silty clay was contacted below the fill and the buried organic clayey silt layer in all of the boreholes, with the exception of Borehole No. 23-5. The silty clay extends to depths ranging from 2.2 m to 4.5 m depths (Elevation 85.7 m to Elevation 82.7 m). The silty clay consists of an upper desiccated/weathered brown crust underlain by a weaker un-desiccated/unweathered grey silty clay. The weaker grey silty clay is not present beneath the brown silty clay in Borehole No. 23-2, 23-3 and 23-6.

6.5.1 Upper Desiccated Brown Silty Clay Crust

The upper brown desiccated silty clay crust extends to depths of 2.1 m to 2.8 m (Elevation 85.4 m to Elevation 84.3 m). The brown silty clay contains sand seams. The undrained shear strength of the crust is 90 kPa to 150 kPa indicating the brown silty clay has a stiff to very stiff consistency. The natural moisture content and unit weight of the silty clay crust is 11 percent to 76 percent and 16.5 kN/m³ to 18.5 kN/m³ respectively.

Results from the grain-size analysis and Atterberg limit determination conducted on two (2) samples of the upper brown silty clay are summarized in Table II. The grain-size distribution curves are shown in Figures 18 and 19.

Table II: Summary of Results from Grain-Size Analysis and Atterberg Limit Determination – Brown Silty Clay Samples										
Borehole No. (BH) Sample No. (SS)	Depth (m)	Grain-Size Analysis (%) and Atterberg Limits (%)								Soil Classification
		Gravel	Sand	Silt	Clay	Moisture Content	Liquid Limit	Plastic Limit	Plasticity Index	
BH23-3: SS3	1.5-2.1	0	7	30	63	41	50	23	27	Silty Clay of Medium to High Plasticity (CI-CH) - trace sand
BH23-9: SS2	0.8-1.4	0	17	21	62	35	52	22	30	Silty Clay of High Plasticity (CH) – some sand

Based on a review of the results of the grain-size analysis and Atterberg limits, the soil may be classified as a silty clay of medium to high (CI-CH) with trace to some sand.

6.5.2 Grey Silty Clay

The brown silty clay crust in Borehole Nos. 23-1, 23-4, 23-7 to 23-9, 24-10 and 24-12 to 24-15 is underlain by a grey silty clay. The grey silty clay extends to depths ranging from 3.3 m to 4.5 m (Elevation 84.0 m to Elevation 82.7 m). The undrained shear strength of the grey silty clay is 29 kPa to 100 kPa indicating the silty clay has a firm to stiff/very stiff consistency. The firm zone of the silty clay exhibiting a low undrained shear strength value of 29 kPa is locally present from 3.1 m to 4.1 m depth (Elevation 84.4 m to Elevation 83.4 m) in Borehole No. 23-1 and at a 2.9 m depth (Elevation 84.3 m) in Borehole No. 24-15. The natural moisture content of the grey silty clay is 53 percent to 75 percent.

Results from the grain-size analysis and Atterberg limit determination conducted on eight (8) samples of the lower grey silty clay are summarized in Table III. The grain-size distribution curves are shown in Figures 20 to 27.

Table III: Summary of Results from Grain-Size Analysis and Atterberg Limit Determination – Grey Silty Clay Samples

Borehole No. (BH) Sample No. (SS)	Depth (m)	Grain-Size Analysis (%) and Atterberg Limits (%)								Soil Classification
		Gravel	Sand	Silt	Clay	Moisture Content (%)	Liquid Limit	Plastic Limit	Plasticity Index	
BH23-1: SS4	3.4-3.7	0	6	32	62	65	49	21	28	Silty Clay of Medium Plasticity (CI) - trace sand
BH23-7-SS4	3.0-3.6	0	8	34	58	55	51	19	32	Silty Clay of High Plasticity (CH) - trace sand
BH 24-10 – SS4	2.3-2.9	4	2	34	60	62	53	21	32	Silty Clay of High Plasticity (CH) – trace gravel and sand
BH 24-12: SS5	3.0-3.5	0	11	49	50	53	47	19	28	Silty Clay of Medium Plasticity (CI) – some sand
BH 24-13: SS5	3.0-3.5	0	2	40	58	75	52	22	30	Silty Clay of High Plasticity (CH) – trace sand
BH 24-14: SS5	3.0-3.5	0	7	40	53	55	42	16	26	Silty Clay of Medium Plasticity (CI) – trace sand
BH 24-15: SS5	3.0-3.5	1	3	41	55	54	50	21	29	Silty Clay of Medium to High Plasticity (CI-CH) – trace gravel and sand
BH 24-15: SS6	3.8-4.3	5	18	40	37	61	36	16	20	Silty Clay of Medium Plasticity (CI) – some sand, trace gravel

Based on a review of the results of the grain-size analysis and Atterberg limits, the soil may be classified as a silty clay of medium to high plasticity (CI-CH) with trace gravel and trace to some sand.

A consolidation test was conducted on one (1) sample of the grey silty clay. The soil parameters derived from the consolidation test results are summarized in Table IV and the consolidation test result report is shown in Appendix D.

Table IV: Consolidation Test Results – Grey Silty Clay Sample

Borehole No.	Sample No. (Sample Depth, m)	Natural Unit Weight (kN/m ³)	σ_p'	σ_{vo}'	C_c	C_r	e_o	OCR
BH23-1	ST1 (3.0 - 3.6)	16.3	110	45	0.576	0.035	1.623	2.4
NOTES:								
σ_p'	- Apparent pre-consolidation pressure (kPa)			σ_{vo}'	- Calculated existing vertical effective pressure (kPa)			
C_c	- Compression index			C_r	- Recompression index			
e_o	- Initial void ratio			OCR	- Over consolidation ratio			

6.6 Shaley Glacial Till

Beneath the fill in Borehole No. 23-5 and the silty clay in the remaining boreholes, shaley glacial till was contacted and extends to depths of 5.5 m to 6.2 m (Elevation 82.3 m to Elevation 80.3 m). The glacial till consists primarily of a silty sand matrix with a localized sandy silt matrix. Locally, in Borehole Nos. 23-7 and 23-8, the glacial till consists of a silty clay matrix. The glacial till contains varying percentages of fine gravel (in the form of shale fragments), sand, silt and clay. The glacial till contains sand and clay seams. The glacial till may also contain possible cobbles and boulders. Based on the SPT N-values of 0 to 96, the glacial till is in a very loose to very dense state. Based on the SPT-N-values of the silty clay portion of the glacial till in Borehole Nos. 23-7 and 23-8 of 0 to 5, the silty clay portion of the glacial till has a very soft to firm consistency. In some boreholes, the SPT N-value is high for low sampler penetration, such as 50 for 125 mm of sampler penetration. This may be a result of the sampler making contact with a possible cobble, boulder or concentrated zone of seams of shale fragments. The natural moisture content of the glacial till ranges from 7 percent to 39 percent.

The results from the grain-size analysis and Atterberg limit determination conducted on seven (7) samples of the glacial till are summarized in Table V. The grain-size distribution curve is shown in Figures 28 to 34.

Table V: Summary of Results from Grain-Size Analysis and Atterberg Limit Determination – Glacial Till Samples

Borehole No. (BH): Sample No. (SS)	Depth (m)	Grain-Size Analysis (%) and Atterberg Limits (%)								Soil Classification
		Gravel	Sand	Silt	Clay	Moisture Content	Liquid Limit	Plastic Limit	Plasticity Index	
BH 23-2: SS4	2.3-2.9	6	46	29	19	39	29	16	13	Silty Sand (SM) – some clay of low plasticity, trace gravel
BH 23-3: SS5	3.8-4.4	9	42	32	17	13	19	15	4	Silty Sand (SM) – some clay of low plasticity, trace gravel
BH 23-4: SS5	4.6-5.2	14	38	33	15	14	22	11	11	Silty Sand (SM) – some gravel and clay of low plasticity
BH 23-7: SS5	4.6-5.2	10	35	36	19	17	24	12	12	Silty Clay of Low Plasticity (CL) – sandy, trace gravel
BH 23-9: SS5	4.6-5.2	22	46	27	5	9	-	-	Non-Plastic	Silty Sand (SM) – gravelly, trace clay
BH 24-12: SS7	4.6-5.2	9	47	29	15	18	20	14	6	Silty Sand (SM) – some clay of low plasticity, trace gravel
BH 24-13: SS7	4.6-5.2	15	37	34	14	14	21	14	7	Silty Sand (SM) – some gravel and clay of low plasticity

Based on a review of the test results of the grain-size analysis and Atterberg limits, the glacial till may be classified as a silty sand (SM) with trace to some gravel/gravelly and trace to some clay to a silty clay of low plasticity (CL) that is sandy with trace gravel. The glacial till may contain possible cobbles and boulders.

6.7 Highly Weathered (Soil Like) Shale Bedrock

Highly weathered shale bedrock (soil like) was encountered underlying the shaley glacial till in Borehole Nos. 23-1, 23-2 and 23-5 at 5.5 m to 6.2 m depths (Elevation 82.3 m to Elevation 81.3 m). It was possible to auger 300 mm to 700 mm into the highly weathered shale bedrock.

6.8 Inferred and Actual Bedrock

Auger and casing refusal was met at 5.6 m to 6.9 m depths (Elevation 81.6 m to Elevation 80.0 m) in Borehole Nos. 23-3, 23-4, 23-7, 23-8, 24-10 and 24-12 to 24-15 on inferred cobbles, boulders or bedrock. The presence of the bedrock was proven by rock coring technique in Borehole Nos. 23-1 (below the augered weathered zone), 23-6 and 23-9. The bedrock was encountered at a 6.2 m depth (Elevation 81.3 m to Elevation 80.3 m) in these boreholes. Photographs of the bedrock cores are shown in Appendix E.

The bedrock is black shale of the Carlsbad formation. A review of the borehole logs indicates that the total core recovery (TCR) ranges between 89 percent and 100 percent and the rock quality designation (RQD) ranges between 33 percent and 83 percent indicating the bedrock is of a fair to good quality. In Borehole No. 23-1, the upper 900 mm of the shale bedrock from 6.7 m to 7.6 m depths (Elevation 80.8 m to Elevation 79.9 m) has an RQD value of 0 percent indicating a very poor quality of rock.

Unit weight determination and unconfined compressive strength tests were conducted on three (3) rock core sections. The test results are summarized in Table VI.

Table VI: Summary of Unconfined Compressive Strength Test Results – Bedrock Cores

Borehole (BH) No.: Run No.	Depth (m)	Unit Weight (kN/m ³)	Unconfined Compressive Strength (MPa)	Classification of Rock with respect to Strength
BH23-1: Run3	9.5-9.7	25.6	34.3	Medium Strong R3
BH23-6: Run1	7.0-7.2	25.8	21.3	Weak R2
BH23-9: Run2	7.5-7.7	26.2	41.5	Medium Strong R3

A review of the test results in Table VI indicates the strength of the rock may be classified as weak (R2) to medium strong (R3) in accordance with the Canadian Foundation Engineering Manual (CFEM), Fourth Edition, 2006.

6.9 Groundwater Level Measurements

A summary of the groundwater level measurements taken in the boreholes equipped with standpipes and monitoring wells on January 9 and April 17, 2024 is shown in Table VII.

Borehole No.	Ground Surface Elevation (m)	Date of Measurement (Elapsed Time in Days from Date of Installation)	Groundwater Depth Below Ground Surface (Elevation), m
BH 23-2	87.88	April 17, 2024 (138 days)	1.7 (86.2)
BH23-2	87.88	January 9, 2024 (39 Days)	1.9 (86.0)
BH 23-3	87.60	April 17, 2024 (146 days)	1.9 (85.7)
BH23-3	87.60	January 9, 2024 (47 Days)	1.8 (85.8)
BH 23-4	87.32	April 17, 2024 (138 days)	2.7 (84.6)
BH23-4	87.32	January 9, 2024 (39 Days)	2.7 (84.6)
BH 23-8	87.15	April 17, 2024 (146 days)	1.1 (86.1)
BH23-8	87.15	January 9, 2024 (49 Days)	1.3 (85.9)
BH 24-10	87.69	April 17, 2024 (22 days)	1.3 (86.4)

Based on the April 17, 2024 set of measurements, the groundwater level ranges from 1.1 m to 2.7 m depths (Elevation 86.4 m to Elevation 84.6 m).

The groundwater levels were determined in the boreholes at the time and under the condition stated in the report. Note that fluctuations in the level of groundwater may occur due to a seasonal variation such as precipitation, snowmelt, rainfall activities, and other factors not evident at the time of measurement and therefore may be at a higher level during wet weather periods.

7. Site Classification for Seismic Site Response and Liquefaction Potential of Soils

7.1 Liquefaction Potential of Soils

Liquefaction analysis was conducted using the data collected from the boreholes and the CPTs. The analysis indicates the silty clay above the glacial till is not liquefiable during a seismic event. The analysis indicates the very loose to compact zone of the glacial till is liquefiable during a seismic event with an average factor of safety of less than 1.0. The glacial till is liquefiable in Blocks 3,8,10,12,13 and 15. The glacial till is not liquefiable in Blocks 1,2,6 and 14. Post-liquefaction settlements were calculated to range from 56 mm to 168 mm. The approximate area of the liquefiable glacial till on site is shown in Figure 3. The results of the liquefaction analysis are shown in Appendix F. It is not known if the subsurface soils in Blocks 4,5,7 and 9 are liquefiable. However, since these blocks are located between blocks where the glacial till has been determined to be liquefiable, Blocks 4,5,7 and 9 along with Block 6 are included within the approximate area of the liquefiable glacial till shown in Figure 3.

It is interesting to note that Blocks 1 and 14 are located directly across, north and south of, and in line with The Boys and Girls Club of Ottawa property where EXP conducted a geotechnical investigation for the club in 2021 (EXP Geotechnical report dated March 5, 2021 and EXP Project No. OTT-0018293-J5). The 2021 geotechnical investigation indicates that the subsurface soils at the Boys and Girls Club of Ottawa are not liquefiable during a seismic event, which is similar to the findings at Blocks 1 and 14 of the proposed development.

Ground improvement at the site will be required to address the presence of the liquefiable soils to ensure performance of the buildings and basement floor slabs (lowest slabs) during a seismic event. A local specialized contractor was contacted and confirmed that the site can be improved to address the liquefiable soil and to possibly improve the bearing pressures recommended for the footings to support the proposed buildings. The contractor indicated that controlled modulus columns (CMCs) is the most appropriate method to improve the ground at the site.

7.2 Site Classification for Seismic Site Response

Since liquefiable soils have been established on site, Tabbe 4.1.8.4.A of the 2012 OBC (as amended January 2022) indicates that for liquefiable soils, the site classification for seismic response is **Class F**. However, the OBC permits for the determination of the site classification for seismic response, that the presence of liquefiable soils can be ignored, provided the proposed buildings will be designed for a fundamental period of vibration equal to or less than 0.5 seconds.

For the case where the liquefiable soils are ignored by designing the proposed buildings for a fundamental period of vibration equal to or less than 0.5 seconds or are addressed by ground improvement, data from SCPTu 3 and SCPTu 5 was used to determine the site classification for seismic response. SCPTu 3 and SCPTu 5 measured the shear wave velocity within the silty clay and glacial till. The average shear wave velocity was determined to be 125 m/s. Based on an assumed shear wave velocity for the underlying shale bedrock of 1000 m/s from Table 4.1.8.4.A of the 2012 Ontario Building Code (as amended January 1, 2022), the weighted average of the shear wave velocity for a 30 m depth is 1164 m/s. Based on Table 4.1.8.4.A of the 2012 OBC (as amended January 2022), for a shear wave velocity of 1164 m/s and that the underside of the footings will be greater than 3.0 m from the bedrock, the classification of the site for seismic response is **Class C**.

7.3 Conclusion

It is EXP's opinion that consideration should be strongly given to improving the ground at the site to address the liquefaction issue to ensure the long-term satisfactory performance of the proposed buildings and basement floor slabs (lowest floor slab) during a seismic event, since the calculated post-liquefaction settlements may render the proposed buildings non-operational. The ground improvement may also increase or improve the bearing pressure at serviceability limit state (SLS) and factored geotechnical resistance at ultimate limit state (ULS) values recommended in this report for the proposed site grade raise.

8. Grade Raise Restrictions

The site is underlain by a sensitive marine clay deposit that is prone to consolidation settlement if overstressed by loads imposed on it by site grade raise, foundations and by the permanent lowering of the groundwater level following construction. Overstressing of the clay will result in its consolidation and subsequent settlement of foundations, which may exceed tolerable limits of the structure resulting in cracking of the structure.

Stantec indicated that the proposed site grade raise in the blocks will be 1.0 m above the elevation of the centreline of the proposed new U-shaped access road. Based on this criterion, a summary of the proposed estimated design grade raise at the block numbers and access road is shown in Table VIII. The information from the boreholes from the current geotechnical investigation and from the 2008 EXP boreholes was used in evaluating the acceptability of the proposed site grade raise. As previously noted, the geodetic ground surface elevations for some of the 2008 borehole/monitoring well locations were interpolated from the spot elevations provided on the 2023 draft functional grading plan by Stantec. Therefore, the ground surface elevations at these borehole locations are considered approximate. The 2008 boreholes/monitoring wells are identified in Table VIII by 08 before the borehole number, for example BH 08-12.

Table VIII: Summary of Proposed Site Grade Raise

Block Number (Building Type)	Closest Boreholes	Proposed Estimated Site Grade Raise (m)
Block 1 (Apartment Building)	BH 23-5 MW08-14 to MW08-17	0.9
Block 2 (Townhouse Building)	BH 23-1 BH 23-2	0.7
Block 3 (Townhouse Building)	BH 23-2	0.5
Block 4 (Townhouse Building)	BH 23-2 BH 23-3	0.5
Block 5 (Townhouse Building)	BH 23-3 BH08-12	0.7
Block 6 (Townhouse Building)	BH 23-3	1.0
Block 7 (Townhouse Building)	BH 23-3	1.0
Block 8 (Townhouse Building)	BH 23-3 BH 23-4	1.4
Block 9 (Townhouse Building)	BH 23-4	1.8
Blocks 10 and 11 (Townhouse Building)	BH 23-4	2.3
Block 12 (Townhouse Building)	BH 23-4 BH 23-7 BH 08-13	2.3
Block 13 (Townhouse Building)	BH 23-7	2.5
Block 14 (Apartment Building)	BH 23-8 BH 23-9 BH 08-10	2.5
Block 15 (Townhouse Building)	BH 23-6 BH 08-11	1.9

Table VIII: Summary of Proposed Site Grade Raise

Block Number (Building Type)	Closest Boreholes	Proposed Estimated Site Grade Raise (m)
North Portion of East-West Leg of Subdivision Access Road	BH 23-1	Ranges from Cut Area to 0.3 m Site Grade Raise
North-South Leg of Subdivision Access Road	BH 23-2 BH 08-12	Ranges from Cut Area to 0.8 m Site Grade Raise
South Portion of East-West Leg of Subdivision Access Road	BH 23-8	Ranges from Cut Area to 0.8 m Site Grade Raise

Notes for Table VIII:

1. The draft functional grading plan, Drawing No. GP-1, dated November 15, 2023 (Revision No. 1), prepared by Stantec used to determine the proposed estimated site grade raise.
2. As indicated by Stantec, the proposed grade raise in the blocks was determined by adding 1.0 m to the design centreline elevation of the proposed horizontal U-shaped subdivision access road within the new residential subdivision. The section of the access road opposite the blocks was used in determining the proposed site grade raise for the blocks.
3. The acceptability of the site grade raise has taken into consideration a 0.5 m permanent groundwater lowering.

Based on a review of Table VIII, the estimated grade raise at the blocks and along the subdivision access road is anticipated to range from 0.5 m to 2.5 m. Along the proposed subdivision road, there are some cut areas. The proposed site grade raise indicated for each block and along the proposed subdivision access road are considered acceptable from a geotechnical perspective in conjunction with the recommended SLS and factored ULS values for the footings in Section 10 of this report. It is recommended that should the magnitude of the site grade raise change and be different than indicated in Table VIII, EXP should be contacted to review the acceptability of the site grade raise and provide updated SLS and factored ULS values or footings.

9. Site Grading

Site grading within the **proposed building footprints** should consist of the excavation and removal of the existing fill, soil berms down to the native soils. Site grading will also require the excavation and removal of all surficial topsoil layers, reclaimed asphalt pavement (RAP), fill, buried organic soil layers and organic stained soils down to the native soil which is anticipated to consist of silty clay and glacial till.

For engineered fill pad areas, the native subgrade should be examined by a geotechnician. Any loose/soft areas identified during the subgrade examination should be excavated, removed and replaced with Ontario Provincial Standard Specification (OPSS) Granular B Type II material compacted to 100 percent standard Proctor maximum dry density (SPMDD). Once the subgrade has been approved, the grades may be raised to the design underside footing and floor slab elevation by an engineered fill pad constructed in accordance with Section 10.1 of this report.

Site grading within the **proposed outdoor park, parking lots and access road areas** should consist of the removal of surficial topsoil and organic stained soils. The subgrade should be proofrolled in the presence of a geotechnician. Any loose/soft areas identified during the proofrolling process should be excavated, removed, and replaced with Ontario Provincial Standard Specification (OPSS) Granular B Type II or OPSS Select Subgrade Material (SSM) compacted to 95 percent standard Proctor maximum dry density (SPMDD). Once the subgrade has been approved, the grades may be raised to the design subgrade level of the pavement structure by approved on site material and/or OPSS Select Subgrade Material (SSM) compacted to 95 percent SPMDD.

In place density tests should be performed on each lift of placed material to ensure that it has been compacted to the project specifications.

10. Foundation Considerations

The draft functional grading plan dated November 15, 2023 (Revision No. 1) and prepared by Stantec indicates the site is divided into fifteen (15) building blocks namely Blocks 1 to 15. The residential development will consist of low-rise apartment buildings (2 to 3-storeys) at Blocks 1 and 14 and townhouse-type buildings at the remaining blocks.

It is our understanding that it is proposed to support the new buildings by footings set at a specified underside footing elevation. Stantec indicated that the proposed elevation of the underside of the footing (USF) for the buildings will be 1.8 m below the proposed design elevation of the centreline of the U-shaped access road and the site grade raise will be 1.0 m above the proposed design elevation of the centreline of the proposed new U-shaped access road.

For the blocks located within the approximate area of the liquefiable soil shown in Figure 3, if the post-liquefaction settlements of 56 mm to 168 mm are acceptable and can be tolerated by the building foundations and slab-on-grade, the proposed buildings may be supported by spread and strip footings designed to bear on the native silty clay, glacial till or engineered fill (constructed on the native soils) and the lowest floor slab (basement slab) may be designed as a slab-on-grade supported by the native soils. The footings founded at the estimated underside of footing elevation (USF) determined from the Stantec drawing and indicated in Table IX may be designed for the bearing pressure at SLS and factored ULS values indicated in Table IX.

If the post-liquefaction settlements for the blocks located within the approximate area of the liquefiable soil shown in Figure 3 are not acceptable and cannot be tolerated by the building foundations and slab-on-grade, ground improvement will be required. Once ground improvement has been completed, the proposed buildings may be supported by spread and strip footings founded on the improved soil and the lowest floor slab (basement slab) may be designed as a slab-on-grade supported by the improved soil. The footings founded at the USF indicated in Table IX may be designed for the SLS and factored ULS values recommended in Table IX of this report. The total and differential settlements of the footings founded on the improved soil will be within normally tolerated limits of 25 mm total settlement and 19 mm differential settlement. It is possible that the recommended SLS and factored ULS values along with the site grade raise can be increased as a result of the ground improvement.

The existing topsoil, RAP layers, buried organic soil layer and fill (improved or not improved) are not considered suitable to support building foundations and floor slabs.

For the two (2) proposed low-rise apartment buildings (2 to 3-storeys) to be located at Blocks 1 and 14 in a non-liquefiable area, the recommended SLS and factored ULS values for footings may be not sufficient to support the proposed buildings. In this case, the proposed buildings may be supported by pile foundations driven to practical refusal into the underlying shale bedrock and designed in end bearing. Caisson foundations are considered to be problematic due to the high groundwater level in combination with the very loose to compact zone of the silty sand glacial till below the groundwater level. Also, it is anticipated that with caissons, costs will be incurred from the removal and disposal of the soil spoil generated from each caisson. As an alternative to piles, even though Blocks 1 and 14 do not have liquefiable soils, if it is decided to use ground improvement at the other blocks (with liquefiable soils), ground improvement may also be considered for Blocks 1 and 14 to improve the SLS and factored ULS values sufficiently so that the proposed apartment buildings may be supported by footings founded on the improved soil.

Footing and pile foundation are discussed in the following sections of this report.

10.1 Footings

It is considered feasible to support the proposed buildings by strip and spread footings founded at the proposed underside footing elevation on the native soils or on an engineered fill pad constructed on the native soils and designed for the bearing pressure at SLS and factored geotechnical resistance at ULS indicated in Table IX. The bearing pressure at serviceability limit state (SLS) and the factored geotechnical resistance at ultimate limit state (ULS) values provided in Table IX are for a maximum 1.5 m wide strip footing and maximum 3.0 m by 3.0 m square pad footing and for the proposed site grade raise indicated in Table IX. The information from the boreholes and CPTs from the current geotechnical investigation and from the 2008 EXP boreholes were used in determining the SLS and factored ULS values. As previously noted, the geodetic ground surface elevations for some of the 2008 borehole/monitoring well locations were interpolated from the spot elevations provided on the 2023 draft functional grading plan by Stantec. Therefore, the ground surface elevations at these borehole locations are considered approximate. The 2008 boreholes/monitoring wells are identified in Table IX by 08 before the borehole number, for example BH 08-12.

Table IX: Summary of Proposed Site Grade Raise, Founding Elevation and Recommended SLS/Factored ULS Values for Footings for Proposed Buildings

Block Number (Building Type)	Closest Boreholes/Con e Penetration Test (CPT)	Proposed Site Grade Raise (m)	Proposed Underside of Footing Elevation (m)	Founding Material	Bearing Pressure at SLS (kPa)	Factored Geotechnical Resistance at ULS (kPa)
Block 1 (Apartment Building)	BH 23-5 MW08-14 CPTu 1	0.9	85.2	Engineered Fill Pad Constructed Shaley Glacial Till	110	165
Block 2 (Townhouse Building)	BH 24-10	0.7	85.6	Stiff to Very Stiff Silty Clay	175	260
Block 3 (Townhouse Building)	BH 23-2 CPTu 2	0.5	85.6	Loose to Compat Shaley Glacial Till	70	105
Block 4 (Townhouse Building)	BH 08-12	0.5	85.6	Compact Glacial Till	150	225
Block 5 (Townhouse Building)	BH 23-3 BH08-12	0.7	85.7	Very Stiff Silty Clay Compact Glacial Till	80 150	120 225
Block 6 (Townhouse Building)	BH 23-3 SCPTu 3	1.0	85.7	Very Stiff Silty Clay	80	120
Block 7 (Townhouse Building)	BH 23-3	1.0	85.7	Very Stiff Silty Clay	80	120
Block 8 (Townhouse Building)	BH 24-12	1.4	85.8	Stiff Silty Clay	75	110
Block 9 (Townhouse Building)	BH 24-12	1.8	86.0	Stiff Silty Clay	75	110
Blocks 10 and 11 (Townhouse Building)	BH 23-4 SCPTu 5	2.3	86.0	Very Stiff Silty Clay	60	90
Block 12 (Townhouse Block)	BH 24-13	2.3	86.2	Stiff Silty Clay	110	165
Block 13 (Townhouse Building)	BH 23-7 CPTu 6	2.5	86.1	Very Stiff Silty Clay	105	160
Block 14 (Apartment Building)	BH 24-14 BH 23-9 BH 08-10	2.5	85.2	Stiff to Very Stiff Silty Clay	50	75
Block 15 (Townhouse Building)	BH 24-15 CPTu 4	1.9	85.6	Firm to Very Stiff Silty Clay	40	60

Notes for Table IX:

1. The draft functional grading plan, Drawing No. GP-1, dated November 15, 2023 (Revision No. 1), prepared by Stantec was used to determine the proposed site grade raise and underside of footing elevation.
2. As indicated by Stantec, the proposed grade raise in the blocks was determined by adding 1.0 m to the design centreline elevation of the proposed horizontal U-shaped access road within the new residential subdivision. The section of the access road opposite the blocks was used in determining the proposed site grade raise of the blocks.
3. As indicated by Stantec, the underside of footing elevation (USF) was determined by deducting 1.8 m from the design centreline elevation of the proposed horizontal U-shaped access road within the new residential subdivision. The section of the access road opposite the blocks was used in determining the proposed site grade raise of the blocks.
4. The factored geotechnical resistance at ULS includes a geotechnical resistance factor of 0.5.
5. The SLS and factored ULS values have taken into consideration a 0.5 m permanent groundwater lowering.

For footings founded on non-liquefiable soils or on improved ground, total and differential settlements of footings indicated for each block in Table IX will be in the order of 25 mm and 19 mm respectively.

For footings founded on liquefiable soils, the total settlement of the footings will include the sum of the 25 mm and the estimated post-liquefaction settlement of 56 mm to 168 mm resulting in an estimated total settlement of 81 mm to 193 mm. Total differential settlements may be in the approximate order of 61 mm to 145 mm.

As an alternative to the SLS and factored ULS values provided for each block in Table IX, the footings for all the building blocks set at the USF indicated in Table IX may be designed for an overall bearing pressure at SLS of 60 kPa and factored geotechnical resistance at ULS of 90 kPa. The exception to this is Block 1 where a higher SLS of 110 kPa and factored ULS of 160 kPa may be utilized for design purposes and Block 14 and 15 where lower SLS values of 40 kPa and 50 kPa and factored ULS values of 60 kPa and 75 kPa may be used for design purposes.

If the proposed design underside of footing elevation and/or the site grade raise for the blocks and the proposed subdivision access road will be different than indicated in Tables VIII and IX, it is recommended that EXP should be contacted to review the acceptability of the proposed site grade raise and provide updated SLS and factored ULS values for the footings.

Based on recent groundwater level measurements from the boreholes and groundwater level measurements determined from the CPTs, the underside of footing elevations at Blocks 2 to 6, 14 and 15 are approximately 0.3 m to 0.8 m below the groundwater level. The underside of footing elevations in the remaining blocks are at or above the measured groundwater level. It is our understanding that City of Ottawa requirements for gravity driven stormwater drainage systems for developments assumed to be similar to this type of development require the elevation of the underside of the footing (USF) to be at or above the spring line of the storm sewer and above the groundwater level. To satisfy this requirement by the City of Ottawa, consideration should be given to raising the USF elevation where required. The raising of the USF may affect the recommended SLS and factored ULS values provided in Table IX of this report. Therefore, as previously indicated, if the USF elevation will change from those indicated in Table IX, it is recommended that EXP should be contacted to review the revised USF elevations and provide revised SLS and factored ULS values.

The construction of the engineered fill pad should consist of the removal of all existing fill, surficial and buried topsoil (organic) layers and organic stained soils down to the native undisturbed soil. The native subgrade should be examined by a geotechnician. Any loose/soft areas identified during the subgrade examination should be excavated, removed, and replaced with Ontario Provincial Standard Specification (OPSS) Granular B Type II material compacted to 100 percent standard Proctor Maximum Dry Density (SPMDD). Once the native subgrade has been approved, the grades may be raised to the design underside footing and floor slab elevation by the construction of an engineered fill pad. The excavation for the removal of fill and topsoil layers (surficial and buried) and organic stained soils should extend a sufficient distance beyond the limits of the proposed building to accommodate a 1.0 m wide horizontal bench of engineered fill that extends beyond the perimeter of the proposed building on all sides, which should thereafter be sloped at an inclination of 1H to 1V down to the approved subgrade. The engineered fill should consist of OPSS Granular B Type II material that is placed in 300 mm thick lifts and each lift compacted to 100 percent SPMDD. The placement and compaction of the engineered fill can in this way be undertaken to the founding level of the footings. From the footing level to the underside of the floor slab, each lift of the Granular B Type II material should be compacted to 98 percent of SPMDD. The engineered fill should be placed under the full-time supervision of a geotechnician working under the direction of a geotechnical engineer. In-place density tests should be undertaken on each lift of the engineered fill to ensure that it is properly compacted prior to placement of subsequent lift.

For footings founded directly on the approved native soil, the exposed native soil subgrade is susceptible to disturbance due to movement of workers and construction traffic and the prevailing weather conditions during construction. To prevent disturbance to the soil subgrade, the approved footing beds should be covered or protected with a 50 mm thick concrete mud slab within the same day of approval.

All footing beds should be examined by a geotechnical engineer/technician to ensure that the founding surfaces are capable of supporting the design bearing pressure at SLS and that the footing beds have been properly prepared.

A minimum of 1.5 m of earth cover should be provided to the exterior foundations founded on soil of heated structures to protect them from damage due to frost penetration. The frost cover should be increased to 2.1 m for unheated structures if snow will not be removed from their vicinity and to 2.4 m if snow will be removed from the vicinity of the structure. When earth cover is less than the minimum required, an equivalent thermal combination of earth cover and rigid insulation or rigid insulation alone should be provided. EXP can provide developmental comments in this regard, if required.

10.1.1 Footing - Ground Improvement

As previously mentioned, since liquefiable soils have been established at some of the blocks on site, ground improvement can be carried out to address the liquefaction potential of these soils. This improvement can be achieved through the use of Controlled Modulus Columns (CMCs) and must be undertaken by a specialist contractor on the basis of end product specifications.

Following the completion of the ground improvement, the proposed buildings may be supported by footings founded on the improved soils and designed for the recommended bearing pressure at SLS and factored geotechnical resistance at ULS. It is possible that the SLS and factored ULS values recommended in this report along with the proposed magnitude of site grade raise may be increased as a result of the ground improvement.

Pre and post construction surveys of nearby buildings and infrastructure (such as underground services) as well as vibration monitoring during ground improvement would be required to ensure that the nearby structures and infrastructure are not adversely impacted by ground improvement.

10.2 Pile Foundations

For the two (2) proposed low-rise apartment buildings (2 to 3-storeys) to be located at Blocks 1 and 14 and in a non-liquefiable area (refer to Figure 3), if the recommended SLS and factored ULS values for footing are not sufficient to support the proposed buildings, the proposed buildings may be supported by pile foundations. The proposed buildings may be supported by steel H or concrete filled pipe piles designed in end-bearing and driven to practical refusal into the underlying shale bedrock. The bedrock is anticipated to be at 5.5 m to 6.2 m depths (Elevation 82.3 m to Elevation 81.3 m). However, the piles may meet practical refusal at depths below the bedrock surface (5.5 m to 6.2 m depths (Elevation 82.3 m to Elevation 81.3 m).

For piles that are driven to bedrock and designed in end bearing, the piles will have high ultimate geotechnical capacities that may equal or exceed the structural capacity of the steel section of the pile. Therefore, the ultimate geotechnical capacity of the pile at ULS may be taken as equal to the ultimate structural resistance of the steel section of the pile. The factored geotechnical resistance of the pile at ULS is determined by applying a geotechnical resistance factor of 0.4 to the ultimate structural resistance of the pile.

Since the piles are expected to meet refusal in the bedrock, the factored geotechnical resistance at ultimate limit state (ULS) will govern the design. The factored geotechnical resistance values at ULS for various pile sections for Blocks 1 and 14 are shown in Tables X and XI. The factored geotechnical resistance values at ULS are based on steel piles with a yield strength of 350 MPa and concrete compressive strength of 35 MPa and a geotechnical resistance factor of 0.4.

It is noted that the piles will be subjected to down-drag forces (negative skin friction) due to consolidation of the silty clay at Blocks 1 and 14 as a result of the grade raise at the site. The negative skin friction that the piles would be subjected to is also listed in Tables X and XI. The estimated carrying capacity load of a pile may be computed by subtracting the negative skin friction from the factored geotechnical resistance at ULS for Blocks 1 and 14.

Table X: Factored Geotechnical Resistance at Ultimate Limit State (ULS) and Estimated Negative Skin Friction of Steel Pipe and H-Piles – Block 1

Pile Section	Description	Factored Geotechnical Resistance at ULS (kN)	Estimated Negative Skin Friction (kN)	Estimated Load Carrying Capacity of Pile (kN)
Steel Pipe	245 mm O.D. by 10 mm wall thickness	1275	27	1248
	245 mm O.D. by 12 mm wall thickness	1445	27	1418
	324 mm O.D. by 12 mm wall thickness	2120	36	2084
Steel H	HP 310 x 79	1260	42	1218
	HP 310 x 110	1775	43	1732
	HP 310 x 125	2000	44	1956

Table XI: Factored Geotechnical Resistance at Ultimate Limit State (ULS) and Estimated Negative Skin Friction of Steel Pipe and H-Piles – Block 14

Pile Section	Description	Factored Geotechnical Resistance at ULS (kN)	Estimated Negative Skin Friction (kN)	Estimated Load Carrying Capacity of Pile (kN)
Steel Pipe	245 mm O.D. by 10 mm wall thickness	1275	65	1210
	245 mm O.D. by 12 mm wall thickness	1445	65	1380
	324 mm O.D. by 12 mm wall thickness	2120	86	2034
Steel H	HP 310 x 79	1260	102	1158
	HP 310 x 110	1775	104	1671
	HP 310 x 125	2000	105	1895

Total and differential settlement of the piles are expected to be less than 10 mm.

To achieve the capacity given previously, the pile-driving hammer must seat the pile in the overburden without overstressing the pile material. For guidance purposes, it is estimated that a hammer with rated energy of 54 kJ to 70 kJ (40,000 to 52,000 ft. lbs.) per blow would be required to drive the piles to practical refusal. Practical refusal is considered to have been achieved at a set of 5 blows for 6 mm or less of pile penetration. However, the driving criteria for a particular hammer-pile system must be established at the beginning of the project using the Pile Driving Analyzer.

The piles should be equipped with a driving shoe to protect them from damage during driving as per Ontario Provincial Standard Drawing (OPSD) 3001.100, Type II, Revision No. 2 dated November 2017.

A number of test piles (5 percent of the total number of piles) should be monitored with the Pile Driving Analyzer during the initial driving and re-striking at the beginning of the project. This monitoring will allow for the evaluation of transferred energy into the pile from the hammer, determination of driving criteria and an evaluation of the ultimate bearing capacity of the piles. Depending on the results of the pile driving analysis, the pile capacity may have to be proven by at least one pile load test for each pile type before production piling begins. If necessary, the pile load test should be performed in accordance with the American Society for Testing and Materials (ASTM) D 1143.

Closed end pipe piles tend to displace a relatively large volume of soil. When driven in a cluster or group, they may tend to jack up the adjacent piles in the group. Consequently, the elevation and the location of the top of each pile in a group should be monitored immediately after driving and after all the piles in the group have been driven. This is to ensure that the piles are not heaving or being displaced. Any piles found to heave more than 3 mm should be re-tapped.

Piles driven at the site may be subject to relaxation (loss of set with time). It is therefore recommended that all the piles should be re-tapped at least 24 hours after initially driving and at 24-hour intervals thereafter until it can be proven that relaxation is no longer a problem.

The installation of the piles at the site should be monitored on a full-time basis by a geotechnician working under the direction and supervision of a qualified geotechnical engineer to verify that the piles are driven in accordance with the project specifications.

The concrete grade beams and pile caps for heated structures should be protected from frost action by providing the beams and caps with 1.5 m of earth cover. For non-heated structures, the pile caps and beams should be provided with 2.4 m of earth cover in areas where the snow will be removed and 2.1 m of earth cover where the snow will not be removed. Alternatively, frost protection may be provided by rigid insulation or a combination of rigid insulation and earth cover.

A 50 mm thick concrete mud slab is recommended to be installed under the grade beams and pile caps immediately upon excavation and approval of the subgrade to protect the surface of the sandy silt to silty sand and silty clay from disturbance from water, the effects from the weather and foot traffic from construction workers.

Temporary granular roads and mats (at least 900 mm thick) will be required to provide access for the pile driving rig. The actual thickness required for the granular roads and mats will have to be established by the piling contractor, based on the type of piling rig that will be used on site and subsurface condition.

10.3 General Comment

The recommended bearing pressures at SLS and factored geotechnical resistances at ULS have been calculated by EXP from the borehole information for the design stage only. The investigation and comments are necessarily on-going as new information of underground conditions becomes available. For example, more specific information is available with respect to conditions between boreholes, when foundation construction is underway. The interpretation between boreholes and the recommendations of this report must therefore be checked through field monitoring provided by an experienced geotechnical engineer to validate the information for use during the construction stage.

11. Floor Slab and Drainage Requirements

The lowest floor slab (basement slab) for the proposed buildings may be designed and constructed as a slab-on-grade placed on a 200 mm thick, 19 mm sized clear stone bed placed on a minimum 300 mm thick engineered fill pad set on the approved native subgrade constructed in accordance with Section 10.1 of this report. The clear stone will minimize the capillary rise of moisture from the sub-soil to the floor slab. Alternatively, the clear stone layer may be replaced with a 200 mm thick bed of OPSS Granular A overlain by a vapour barrier. Adequate saw cuts should be provided in the floor slabs to control cracking.

The proposed buildings will require a perimeter drainage system. The need for underfloor drainage system for the proposed buildings can be determined once the final design elevation of the basement floor is available.

The floor slab should be set at a minimum of 150 mm higher than the final exterior grade surrounding the buildings.

The final exterior grade surrounding the proposed buildings should be sloped away from the proposed buildings to prevent ponding of surface water close to the exterior walls of the proposed buildings.

12. Lateral Earth Pressure Against Subsurface Walls

The subsurface basement walls for the proposed buildings are typically designed not to support hydrostatic pressure behind the wall. In this case, the subsurface basement walls should be backfilled with free draining material, such as OPSS Granular B Type II compacted to 95 percent SPMD and equipped with a perimeter drainage system to prevent the buildup of hydrostatic pressure behind the walls. The walls will be subjected to lateral static and dynamic (seismic) earth forces. The expressions below assume free draining backfill material, a perimeter drainage system, level backfill surface behind the wall and vertical face on the back side of the wall.

For design purposes, the lateral static earth thrust against the subsurface walls may be computed from the following equation:

$$P = K_0 h (\frac{1}{2} \gamma h + q)$$

where P = lateral earth thrust acting on the subsurface wall, kN/m

K_0 = lateral earth pressure at rest coefficient, assumed to be 0.5 for Granular B Type II backfill material

γ = unit weight of free draining granular backfill; Granular B Type II = 22 kN/m³

h = depth of point of interest below top of backfill, m

q = surcharge load stress, kPa

The lateral dynamic thrust may be computed from the equation given below:

$$\Delta_{pe} = \gamma H^2 \frac{a_h}{g} F_b$$

where Δ_{pe} = dynamic thrust in kN/m of wall

H = height of wall, m

γ = unit weight of backfill material = 22 kN/m³

$\frac{a_h}{g}$ = earth pressure coefficient or Peak Ground Acceleration (PGA) value, 0.361 for the site (2020

National Building Code of Canada Seismic Hazard Tool)

F_b = thrust factor = 1.0

The dynamic thrust does not take into account the surcharge load. The resultant force acts approximately at 0.63H above the base of the wall.

All subsurface walls should be properly dampproofed.

13. Excavation and De-Watering Requirements

13.1 Excess Soil Management

Ontario Regulation 406/19 specifies protocols that are required for the management and disposal of excess soils. As set forth in the regulation, specific analytical testing protocols need to be implemented and followed based on the volume of soil to be managed and the requirements of the receiving site. The testing protocols are specific as to whether the soils are stockpiled or in situ. In either scenario, the testing protocols are far more onerous than have been historically carried out as part of standard industry practices. These decisions should be factored in and accounted for prior to the initiation of the project-defined scope of work. EXP would be pleased to assist with the implementation of a soil management and testing program that would satisfy the requirements of Ontario Regulation 406/19.

For the environmental aspects of the subsurface soils and groundwater, reference is made to the EXP reports titled, Phase Two Environmental Site Assessment (ESA) and Soil Characterization for the two (2) soil berms on site.

13.2 Excavation

Based on the Stantec draft functional grading plan and site servicing plan, excavations for the construction of the proposed building foundations and installation of the underground services are anticipated to extend to depths ranging from approximately 3.0 m to 4.0 m below existing grade and are expected to be within the fill, silty clay and glacial till and below the groundwater level.

The excavations may be undertaken by conventional heavy equipment capable of removing possible debris within the fill and cobbles and boulders within the glacial till.

Open cut excavations within the soils above the groundwater level are anticipated to be relatively straight forward. If ground improvement is selected to be used on this site, the excavation and dewatering comments and recommendations provided in this report may need to be updated.

All excavations must be undertaken in accordance with the Occupational Health and Safety Act (OHSA), Ontario Reg. 213/91. Based on the definitions provided in OHSA, the subsurface soils on site are considered to be Type 3 and as such must be cut back at 1H:1V from the bottom of the excavation. Within zones of seepage, the excavation side slopes are expected to slough and eventually stabilize at 2H:1V to 3H:1V from the bottom of the excavation. For excavations above the groundwater level or properly dewatered (refer to paragraph below), the installation of the municipal underground services may be undertaken within the confines of a prefabricated support system (trench box) designed and installed in accordance with OHSA.

Open cut excavations that extend into the silty sand to sandy silt glacial till below the groundwater level are anticipated to be more problematic and will require the lowering of the groundwater level prior to the start of excavation. It is anticipated that the base of the excavation in the silty sand to sandy silt glacial till and below the groundwater level may be susceptible to basal instability or base type failure in the form of piping or heave. To minimize the occurrence of base type failure, it is recommended that the groundwater level should be lowered by at least 1.0 m below the bottom of the excavation prior to the start of excavation. This may be achieved by installing deep sumps and pumping with high-capacity pumps. The dewatering contractor should review the subsurface conditions at the site and select the most appropriate method to lower the groundwater level.

Many geologic materials deteriorate rapidly upon exposure to meteorological elements. Unless otherwise specifically indicated in this report, walls and floors of excavations must be protected from moisture, desiccation, and frost action throughout the course of construction.

13.3 De-Watering Requirements

Seepage of the surface and subsurface water into the excavations is anticipated. However, it should be possible remove groundwater entering into excavation by pumping from sumps. In areas of high infiltration or in areas where more permeable soil layers may exist, a higher seepage rate should be anticipated and will require high-capacity pumps to keep the excavation dry (may need to operate 24 hours a day, seven (7) days a week).

As discussed above, to minimize base type failure of excavations that extend below the groundwater level and into the silty sand to sandy silt glacial till, it is recommended that the groundwater level should be lowered by at least 1.0 m below the bottom of

the excavation for the proposed buildings and underground services prior to the start of excavation. These may be achieved by installing deep sumps and pumping with high-capacity pumps. The dewatering contractor should review the subsurface conditions at the site and select the most appropriate method to lower the groundwater level.

For construction dewatering, an Environmental Activity and Sector Registry (EASR) approval may be obtained for water takings greater than 50 m³ and less than 400 m³ per day. If more than 400 m³ per day of groundwater are generated for dewatering purposes, then a Category 3 Permit to Take Water (PTTW) must be obtained from the Ministry of the Environment, Conservation and Parks (MECP). A Category 3 PTTW would require a complete hydrogeological assessment and would take at least 90 days for the MECP to process once the application is submitted.

Although this investigation has estimated the groundwater levels at the time of the fieldwork, and commented on dewatering and general construction problems, conditions may be present which are difficult to establish from standard boring and excavating techniques and which may affect the type and nature of dewatering procedures used by the contractor in practice. These conditions include local and seasonal fluctuations in the groundwater table, erratic changes in the soil profile, thin layers of soil with large or small permeabilities compared with the soil mass, etc. Only carefully controlled tests using pumped wells and observation wells will yield the quantitative data on groundwater volumes and pressures that are necessary to adequately engineer construction dewatering systems.

14. Pipe Bedding Requirements

It is anticipated that the subgrade for the proposed underground services will consist of existing fill, native silty clay and glacial till.

The pipe bedding including material specifications, thickness of cover material and compaction requirements should conform to City of Ottawa specifications, drawings and special provisions. The bedding and cover material should be compacted to a minimum of 95 percent standard Proctor maximum dry density (SPMDD).

The bedding thickness may be increased in areas where the subgrade is subject to disturbance. If this is the case, trench base stabilization techniques, such as the removal of loose material, placement of sub-bedding, consisting of OPSS Granular B Type II completely wrapped in a non-woven geotextile, may be used.

For paved surfaces that will be located over service trenches, it is recommended that the trench backfill material within the 1.8 m frost zone, should match the existing material exposed along the trench walls to minimize differential frost heaving of the subgrade. The trench backfill should be placed in 300 mm thick lifts and each lift should be compacted to 95 percent SPMDD. Alternatively, frost tapers may be used.

If the backfill for the service trenches will consist of granular fill, clay seals should be installed in the service trenches at select intervals (spacing) as per City of Ottawa Drawing No. S8. The seals should be 1 m wide, extend over the entire trench width and from the bottom of the trench to the underside of the pavement structure. The clay should be compacted to 95 percent SPMDD. The purpose of the clay seals is to prevent the permanent lowering of the groundwater level.

The underground services should be installed in short open trench sections that are excavated and backfilled the same day.

15. Backfilling Requirements and Suitability of On-Site Soils for Backfilling Purposes

The materials to be excavated from the site will comprise of topsoil, buried organic soil, fill, silty clay and glacial till. From a geotechnical perspective, the topsoil, buried organic soil and fill are not considered suitable for reuse as backfill material in the interior or exterior of the buildings and should be discarded. These soils may be used for general grading purposes in landscaped areas. Portions of the fill, silty clay and glacial till (free of cobbles and boulders) above the groundwater level may be re-used as fill in locations away from the proposed buildings as backfill in service trenches and subgrade fill in paved and landscaped areas, subject to further geotechnical examination and testing during construction. These soils are subject to moisture absorption due to precipitation and must be protected at all times from the elements. Subject to additional examination and testing during construction, portions of the fill, silty clay and glacial till (free of cobbles and boulders) below the groundwater level, may be re-used as fill in locations away from the proposed buildings as backfill in service trenches and subgrade fill in paved and landscaped areas, but will likely require air-drying to reduce the moisture content to compact the materials to the specified degree of compaction. Air-drying may be problematic (difficult) since it is weather dependent, may take time and that the soils are subject to moisture absorption from precipitation and must be protected at all times from the elements.

For the environmental aspects of the existing soil, reference should be made to the EXP Phase One and Two Environmental Site Assessments (ESAs) and the Site-Specific Risk Assessment (SSRA).

The soils in the berms on site may be re-used as fill in locations away from the proposed buildings, as backfill in service trenches and subgrade fill in paved and landscaped areas, subject to further geotechnical examination and testing during construction and provided that these soils are suitable for re-use on the site from an environmental perspective. Reference is made to the Soil Characterization for the two (2) soil berms on site regarding the suitability of the soils in the berms for re-use on site from an environmental perspective.

Therefore, it is anticipated that the majority of the material required for backfilling purposes in the interior and exterior of the proposed buildings and in the underground service trenches will need to be imported and should preferably conform to the following specifications:

- Engineered fill under footings for the proposed buildings – OPSS Granular B Type II placed in 300 mm thick lifts and each lift compacted to 100 percent SPMDD,
- Engineered fill under the floor slab of the proposed buildings – OPSS Granular B Type II placed in 300 mm thick lifts and each lift compacted to 98 percent SPMDD,
- Backfill material for footing trenches and against foundation walls located outside the proposed buildings – OPSS Granular B Type II placed in 300 mm thick lifts and each lift compacted to 95 percent SPMDD,
- Trench backfill and subgrade fill should consist of OPSS Granular B Type I or OPSS Select Subgrade Material (SSM) placed in 300 mm thick lifts and each lift compacted to 95 percent SPMDD; and
- Landscaped areas - Clean fill that is free of organics and deleterious material, cobbles and boulders and is placed in 300 mm thick lifts with each lift compacted to 92 percent of the SPMDD.

16. Pavement Structures for Access Road and Parking Lots

The subgrade for the pavement structures is anticipated to consist of fill, native silty clay, OPSS Granular B Type II material and OPSS Select Subgrade Material (SSM). Pavement structure thicknesses required for the access road and parking lots set on the anticipated approved subgrade materials were computed and are shown in Table XII. The pavement structures assume a functional design life of 15 to 20 years. The proposed functional design life represents the number of years to the first rehabilitation, assuming regular maintenance is carried out.

Table XII: Recommended Pavement Structure Thicknesses			
Pavement Layer	Compaction Requirements	Computed Pavement Structure	
		Light Duty Traffic (Cars Only)	Heavy Duty Traffic – Access Road (Emergency Vehicles and Trucks)
Asphaltic Concrete	92 percent-97 percent MRD	65 mm HL3/SP12.5 mm/ Cat. B (PG 58-34)	50 mm HL3/SP12.5 Cat. B (PG 58-34) 60 mm HL8/SP 19 Cat. B (PG 58-34)
OPSS 1010 Granular A Base	100% percent SPMDD	150 mm	150 mm
OPSS 1010 Granular B Type II Sub-base	100% percent SPMDD	450 mm	600 mm

Notes:

1. SPMDD denotes standard Proctor maximum dry density, ASTM, D-698-12e2.
2. MRD denotes Maximum Relative Density, ASTM D2041.
3. The upper 300 mm of the subgrade fill must be compacted to 98 percent SPMDD.
4. The approved subgrade should be covered with a woven geotextile prior to placement of granular sub-base of the pavement structure.

The foregoing design assumes that construction is carried out during dry periods and that the subgrade is stable under the load of construction equipment. If construction is carried out during wet weather and heaving or rolling of the subgrade is experienced, additional thickness of granular material may be required in addition to the woven geotextile indicated in Table XI.

Additional comments for the construction of the access road and parking lots are as follows:

1. As part of the subgrade preparation, the proposed parking areas and the internal access road should be stripped of surficial topsoil and organic stained soil. The subgrade should be properly shaped, crowned, then proofrolled with a heavy vibratory roller in the full-time presence by a geotechnician. Any soft or spongy subgrade areas detected should be sub excavated and properly replaced with suitable approved material or approval OPSS Granular B Type II placed in 300 mm lift and each lift compacted to 95 percent SPMDD (ASTM D698-12e2).
2. The long-term performance of the pavement structure is highly dependent upon the subgrade support conditions. Stringent construction control procedures should be maintained to ensure that uniform subgrade moisture and density conditions are achieved. The need for adequate drainage cannot be over-emphasized. Subdrains should be installed on both sides of the access road(s). Subdrains must be installed in the proposed parking area and on both sides of the roadways at low points and should be continuous between catchbasins to intercept excess surface and subsurface moisture and to prevent subgrade softening. This will ensure no water collects in the granular course, which could result in pavement failure during the spring thaw. The location and extent of sub drainage required within the paved areas should be reviewed by this office in conjunction with the proposed site grading.
3. To minimize the problems of differential movement between the pavement and catchbasins/manhole due to frost action, the backfill around the structures should consist of free-draining granular preferably conforming to OPSS Granular B Type II material. Weep holes should be provided in the catchbasins/manholes to facilitate drainage of any water that may accumulate in the granular fill.

4. The most severe loading conditions on light-duty pavement areas and the subgrade may occur during construction. Consequently, special provisions such as restricted lanes, half-loads during paving, temporary construction roadways, etc., may be required, especially if construction is carried out during unfavorable weather.
5. The finished pavement surface should be free of depressions and should be sloped (preferably at a minimum cross fall of 2 percent) to provide effective surface drainage towards catchbasins. Surface water should not be allowed to pond adjacent to the outside edges of paved areas.
6. Relatively weaker subgrade may develop over service trenches at subgrade level. These areas may require the use of thicker/coarser sub-base material and the use of a geotextile at the subgrade level. If this is the case, it is recommended that additional 150 mm of granular sub-base Granular B Type II should be provided in these areas in addition to the use of a geotextile at the subgrade level.
7. The granular materials used for pavement construction should conform to OPSS 1010 for Granular A and Granular B Type II and should be compacted to 100 percent of the SPMDD (ASTM D698). The asphaltic concrete and its placement should meet OPSS requirements. It should be compacted to 92 to 97 percent of the maximum relative density in accordance with ASTM D2041.

The asphaltic concrete used, and its placement should meet OPSS 1150 or 1151 requirements. It should be compacted from 92 percent to 97 percent of the MRD (ASTM D2041). Asphalt placement should be in accordance with OPSS 310 and OPSS 313.

It is recommended that EXP be retained to review the final pavement structure design and drainage plans prior to construction to ensure they are consistent with the recommendations of this report.

17. Corrosion Potential

Chemical tests limited to pH, sulphate, chloride and resistivity were undertaken on three (3) soil samples. A summary of the results is shown in Table XIII. The laboratory certificate of analysis is shown in Appendix G.

Table XIII: Corrosion Test Results on Soil Samples						
Borehole – Sample No.	Depth (m)	Soil Type	pH	Sulphate (%)	Chloride (%)	Resistivity (ohm-cm)
BH 23-2 SS5	3.0 m - 3.6 m	Shaley Glacial Till	8.33	0.0167	0.0039	2430
BH 23-4 SS4	3.0 m - 3.6 m	Grey Silty Clay	7.97	0.0134	0.0256	1070
BH 23-8 SS5	3.8 m - 4.4 m	Shaley Glacial Till	7.95	0.0205	0.1100	296

The results indicate the soils have a negligible sulphate attack on subsurface concrete. The concrete should be designed in accordance with CSA A.23.1-19.

The results from the resistivity tests indicate that the shaley glacial till is mildly to very corrosive, and the grey silty clay is moderately corrosive to corrosive to bare steel as per the National Association of Corrosion Engineers (NACE). Appropriate measures should be taken to protect the buried bare steel from corrosion.

18. Tree Planting Restrictions

Based on the results of the Atterberg limits of the clayey soils and comparison of the results with the City of Ottawa 2005 Clay Soils Policy and 2017 Tree Planting in Sensitive Marine Clay Soils Guidelines (2017 Tree Planting Guidelines), the clayey soils at this site are considered to have a low/medium potential for soil volume change. Therefore, the tree planting should be carried out in accordance with the 2017 City of Ottawa Tree Planting Guidelines.

A landscape architect should be consulted to ensure the tree planting restrictions and setbacks for the proposed development are in accordance with the applicable City of Ottawa guidelines.

19. General Comments

The comments given in this report are intended only for the guidance of design engineers. The number of boreholes required to determine the localized underground conditions between boreholes affecting construction costs, techniques, sequencing, equipment, scheduling, etc., would be much greater than has been carried out for the design purposes. Contractors bidding on or undertaking the works should, in this light, decide on their own investigations, as well as their own interpretations of the factual borehole results, so that they may draw their own conclusions as to how the subsurface conditions may affect them.

The information contained in this report is not intended to reflect on environmental aspects of the soils and groundwater. Reference should be made to the Phase One and Two Environmental Site Assessments (ESAs), the Site-Specific Risk Assessment (SSRA) and the Soil Characterization of the two (2) soil berms on site for the environmental aspects of the soils and groundwater.

We trust that the information contained in this report will be satisfactory for your purposes. Should you have any questions, please do not hesitate to contact this office.

Sincerely

DRAFT

Susan M. Potyondy, P.Eng.
Senior Geotechnical Engineer
Earth & Environment
Eastern Region

DRAFT

Ismail M. Taki, M.Eng., P.Eng.
Senior Manager
Earth & Environment
Eastern Region